

Db2 12 for z/OS

SQL Reference

Last updated: 2024-05-14



Notes

Before using this information and the product it supports, be sure to read the general information under "Notices" at the end of this information.

Subsequent editions of this PDF will not be delivered in IBM Publications Center. Always download the latest edition from [IBM Documentation](#).

2024-05-14 edition

This edition applies to Db2[®] 12 for z/OS[®] (product number 5650-DB2), Db2 12 for z/OS Value Unit Edition (product number 5770-AF3), and to any subsequent releases until otherwise indicated in new editions. Make sure you are using the correct edition for the level of the product.

Specific changes are indicated by a vertical bar to the left of a change. A vertical bar to the left of a figure caption indicates that the figure has changed. Editorial changes that have no technical significance are not noted.

© **Copyright International Business Machines Corporation 1982, 2024.**

US Government Users Restricted Rights – Use, duplication or disclosure restricted by GSA ADP Schedule Contract with IBM Corp.

Contents

- About this information..... xxiii**
 - Who should read this information..... xxiv
 - Db2 Utilities Suite for z/OS..... xxiv
 - Terminology and citations..... xxiv
 - Accessibility features for Db2 for z/OS..... xxv
 - How to send comments..... xxv
 - How to read syntax diagrams..... xxvi
 - Conventions for describing mixed data values..... xxvii
 - Industry standards for SQL..... xxviii

- Chapter 1. Db2 for z/OS and SQL concepts..... 1**
 - Submitting SQL statements to Db2..... 1
 - Static SQL..... 1
 - Embedded dynamic SQL..... 2
 - Deferred embedded SQL..... 2
 - Interactive SQL..... 2
 - SQL Call Level Interface and Open Database Connectivity..... 3
 - Java database connectivity and embedded SQL for Java..... 4
 - Use of QMF for Workstation..... 4
 - Db2 database objects overview..... 5
 - Db2 schemas and schema qualifiers..... 6
 - Db2 tables..... 7
 - Db2 keys..... 10
 - Constraints..... 11
 - Db2 table columns..... 15
 - Db2 indexes..... 29
 - Db2 views..... 30
 - Aliases..... 32
 - Triggers..... 32
 - User-defined types..... 35
 - Routines in Db2 for z/OS: functions and procedures 35
 - Sequences..... 37
 - Db2 system objects..... 38
 - Db2 catalog..... 38
 - Db2 directory..... 39
 - Active and archive logs..... 40
 - Bootstrap data set..... 40
 - Buffer pools..... 41
 - Data definition control support database..... 41
 - The resource limit facility..... 41
 - Work file database..... 42
 - Application processes and transactions..... 42
 - Subsystem parameters..... 47
 - Storage structures..... 48
 - Db2 databases..... 48
 - Db2 table spaces..... 50
 - Db2 index spaces..... 51
 - Rules for primary and secondary space allocation..... 51
 - Db2 hash spaces (deprecated)..... 53
 - Db2 storage groups..... 54

Application processes, concurrency, and recovery.....	55
Locking, commit, and rollback.....	55
Unit of work.....	55
Unit of recovery.....	56
Rolling back work.....	56
Packages and application plans.....	57
Character conversion.....	59
Character sets and code pages.....	61
Coded character sets and CCSIDS.....	62
Determining the encoding scheme and CCSID of a string.....	63
Expanding conversions.....	67
Contracting conversions.....	68
Distributed relational databases.....	68
Connections.....	68
Distributed unit of work.....	69
Remote unit of work.....	72

Chapter 2. Language elements in SQL.....75

Characters and tokens in SQL.....	75
Identifiers in SQL.....	77
Naming conventions in SQL.....	79
SQL path.....	85
Unqualified object name resolution.....	86
Aliases.....	88
Synonyms (deprecated).....	89
Authorization, privileges, permissions, masks, and object ownership.....	90
Authorization IDs, roles, and authorization names.....	92
Authorization IDs and statement preparation.....	93
Authorization IDs and dynamic SQL.....	94
Authorization IDs and remote execution.....	96
Data types.....	98
Numeric data types.....	99
Numeric host variables.....	102
Character strings.....	102
String unit specifications.....	106
Graphic strings.....	112
Unicode columns in EBCDIC tables.....	113
Binary strings.....	116
Large objects (LOBs).....	116
Datetime values.....	118
Row ID values.....	124
XML values.....	125
User-defined data types.....	126
Distinct types.....	126
Array types and values.....	127
Promotion of data types.....	129
Casting between data types.....	130
Implicit cast from numeric data to string data.....	141
Implicit cast from string data to numeric data.....	142
Assignment and comparison.....	143
Numeric assignments.....	145
String assignments.....	149
Datetime assignments.....	151
Row ID assignments.....	153
XML assignments.....	153
User-defined type assignments.....	153
Assignments to LOB locators.....	156

Numeric comparisons.....	156
String comparisons.....	157
Datetime comparisons.....	158
Row ID comparisons.....	159
XML comparisons.....	159
Conversion rules for comparisons.....	159
User-defined type comparisons.....	164
Rules for result data types.....	166
Constants.....	170
Graphic string constants.....	173
Datetime constants.....	174
Special registers.....	177
General rules for special registers.....	179
Rules for setting special registers by using profile tables.....	181
CURRENT ACCELERATOR special register.....	184
CURRENT APPLICATION COMPATIBILITY special register.....	184
CURRENT APPLICATION ENCODING SCHEME special register.....	185
CURRENT CLIENT_ACCTNG special register.....	186
CURRENT CLIENT_APPLNAME special register.....	187
CURRENT CLIENT_CORR_TOKEN special register.....	189
CURRENT CLIENT_USERID special register.....	189
CURRENT CLIENT_WRKSTNNAME special register.....	190
CURRENT DATE special register.....	192
CURRENT DEBUG MODE special register.....	192
CURRENT DECFLOAT ROUNDING MODE special register.....	193
CURRENT DEGREE special register.....	194
CURRENT EXPLAIN MODE special register.....	194
CURRENT GET_ACCEL_ARCHIVE special register.....	195
CURRENT LOCALE LC_CTYPE special register.....	196
CURRENT MAINTAINED TABLE TYPES FOR OPTIMIZATION special register.....	197
CURRENT MEMBER special register.....	198
CURRENT OPTIMIZATION HINT special register.....	198
CURRENT PACKAGE PATH special register.....	199
CURRENT PACKAGESET special register.....	199
CURRENT PATH special register.....	200
CURRENT PRECISION special register.....	201
CURRENT QUERY ACCELERATION special register.....	202
CURRENT QUERY ACCELERATION WAITFORDATA special register.....	203
CURRENT REFRESH AGE special register.....	204
CURRENT ROUTINE VERSION special register.....	204
CURRENT RULES special register.....	205
CURRENT SCHEMA special register.....	206
CURRENT SERVER special register.....	207
CURRENT SQLID special register.....	207
CURRENT TEMPORAL BUSINESS_TIME special register.....	208
CURRENT TEMPORAL SYSTEM_TIME special register.....	210
CURRENT TIME special register.....	211
CURRENT TIMESTAMP special register.....	212
CURRENT TIME_ZONE special register.....	213
ENCRYPTION PASSWORD special register.....	213
SESSION TIME_ZONE special register.....	214
SESSION_USER special register.....	214
USER special register.....	215
Special registers in a user-defined function or a stored procedure.....	215
Column names.....	219
Qualified column names.....	220
Correlation names.....	220
Column name qualifiers to avoid ambiguity.....	221

Column name qualifiers in correlated references.....	222
Resolution of column name qualifiers and column names.....	223
Variables.....	225
Global variables.....	225
Session variables.....	227
Host variables.....	227
Variables in dynamic SQL.....	230
LOB variables.....	230
LOB locator variables.....	230
XML variables.....	231
LOB or XML file reference variables	232
Result set locator variables.....	234
Array variables.....	234
Host structures in PL/I, C, and COBOL.....	235
Host-variable arrays in PL/I, C, C++, and COBOL.....	236
Functions.....	237
Function invocation.....	239
Function resolution.....	239
Expressions.....	245
Concatenation operators in expressions.....	247
Arithmetic operators in expressions.....	250
Scalar-fullselect.....	256
Datetime operands and durations.....	257
Time zone specific expressions.....	258
Datetime arithmetic in SQL.....	259
Precedence of operations.....	263
CASE expressions.....	264
CAST specification.....	267
XMLCAST specification.....	277
Array element specification.....	278
Array constructor.....	279
OLAP specifications.....	280
ROW CHANGE expression.....	291
Sequence reference.....	292
Predicates.....	296
Basic predicate.....	297
Quantified predicate.....	300
ARRAY_EXISTS predicate.....	302
BETWEEN predicate.....	303
DISTINCT predicate.....	304
EXISTS predicate.....	305
IN predicate.....	306
LIKE predicate.....	308
NULL predicate.....	316
XMLEXISTS predicate.....	316
Search conditions.....	319
Options affecting SQL.....	320
SQL processing options for dynamic statements.....	322
DECFLOAT rounding mode.....	323
Decimal point representation.....	323
Apostrophes and quotation marks as string delimiters.....	324
Katakana characters for EBCDIC.....	325
Mixed data in character strings.....	325
Formatting of datetime strings.....	325
SQL standard language.....	326
Positioned updates of columns.....	326
Mappings from SQL to XML.....	327
Mapping SQL character sets to XML character sets.....	327

Mapping SQL identifiers to XML names.....	327
Mapping SQL data values to XML data values.....	328

Chapter 3. Built-in global variables and session variables..... 329

Built-in global variables.....	329
CATALOG_LEVEL.....	329
CLIENT_IPADDR.....	330
DEFAULT_SQLLEVEL.....	330
GET_ARCHIVE.....	330
MAX_LOCKS_PER_TABLESPACE.....	331
MAX_LOCKS_PER_USER.....	331
MOVE_TO_ARCHIVE.....	332
PRODUCTID_EXT.....	332
REPLICATION_OVERRIDE.....	333
TEMPORAL_LOGICAL_TRANSACTION_TIME.....	334
TEMPORAL_LOGICAL_TRANSACTIONS.....	334
Rules for setting built-in global variables by using profile tables.....	335
Built-in session variables.....	336

Chapter 4. Built-in functions..... 341

List of supported built-in functions.....	341
Aggregate functions.....	353
ARRAY_AGG aggregate function.....	354
AVG aggregate function.....	357
CORR or CORRELATION aggregate function.....	358
COUNT aggregate function.....	358
COUNT_BIG aggregate function.....	359
COVAR_POP or COVARIANCE or COVAR aggregate function.....	360
COVAR_SAMP or COVARIANCE_SAMP aggregate function.....	361
CUME_DIST.....	362
GROUPING aggregate function.....	363
LISTAGG aggregate function.....	364
MAX aggregate function.....	367
MEDIAN aggregate function.....	368
MIN aggregate function.....	369
PERCENTILE_CONT aggregate function.....	370
PERCENTILE_DISC aggregate function.....	371
PERCENT_RANK.....	372
REGR_AVGX, REGR_AVGY, REGR_COUNT,	374
STDDEV_POP or STDDEV aggregate function.....	376
STDDEV_SAMP aggregate function.....	377
SUM aggregate function.....	378
VAR_POP or VARIANCE or VAR aggregate function.....	379
VAR_SAMP or VARIANCE_SAMP aggregate function.....	380
XMLAGG aggregate function.....	381
Scalar functions.....	382
ABS or ABSVAL scalar function.....	382
ACOS scalar function.....	383
ADD_DAYS.....	383
ADD_MONTHS scalar function.....	384
ARRAY_DELETE scalar function.....	386
ARRAY_FIRST scalar function.....	387
ARRAY_LAST scalar function.....	388
ARRAY_NEXT scalar function.....	389
ARRAY_PRIOR scalar function.....	391
ARRAY_TRIM scalar function.....	392
ASCII scalar function.....	393

ASCII_CHR scalar function.....	393
ASCII_STR or ASCIISTR scalar function.....	394
ASIN scalar function.....	395
ATAN scalar function.....	395
ATANH scalar function.....	395
ATAN2 scalar function.....	396
BIGINT scalar function.....	396
BINARY scalar function.....	397
BITAND, BITANDNOT, BITOR, BITXOR, and BITNOT scalar functions.....	398
BLOB scalar function.....	400
BTRIM.....	401
CARDINALITY scalar function.....	402
CCSID_ENCODING scalar function.....	403
CEILING or CEIL scalar function.....	404
CHAR scalar function.....	405
CHAR9 scalar function.....	412
CHARACTER_LENGTH or CHAR_LENGTH scalar function.....	413
CHR scalar function.....	415
CLOB scalar function.....	415
COALESCE scalar function.....	417
COLLATION_KEY scalar function.....	418
COMPARE_DECFLOAT scalar function.....	421
CONCAT scalar function.....	422
CONTAINS scalar function.....	422
COS scalar function.....	425
COSH scalar function.....	425
DATE scalar function.....	425
DAY scalar function.....	426
DAYOFMONTH scalar function.....	428
DAYOFWEEK scalar function.....	429
DAYOFWEEK_ISO scalar function.....	430
DAYOFYEAR scalar function.....	431
DAYS scalar function.....	432
DAYS_BETWEEN.....	433
DBCLOB scalar function.....	434
DECFLOAT scalar function.....	437
DECFLOAT_FORMAT scalar function.....	438
DECFLOAT_SORTKEY scalar function.....	440
DECIMAL or DEC scalar function.....	441
DECODE scalar function.....	443
DECRYPT_BINARY, DECRYPT_BIT, DECRYPT_CHAR, and DECRYPT_DB scalar functions.....	444
DECRYPT_DATAKEY_INTEGER, DECRYPT_DATAKEY_BIGINT, DECRYPT_DATAKEY_DECIMAL, DECRYPT_DATAKEY_VARCHAR, DECRYPT_DATAKEY_CLOB, DECRYPT_DATAKEY_VARGRAPHIC, DECRYPT_DATAKEY_DBCLOB, and DECRYPT_DATAKEY_BIT scalar functions.....	446
DEGREES scalar function.....	449
DIFFERENCE scalar function.....	450
DIGITS scalar function.....	450
DOUBLE_PRECISION or DOUBLE scalar function.....	451
DSN_XMLVALIDATE scalar function.....	452
EBCDIC_CHR scalar function.....	453
EBCDIC_STR scalar function.....	453
ENCRYPT_DATAKEY scalar function.....	454
ENCRYPT_TDES or ENCRYPT scalar function.....	456
EXP scalar function.....	458
EXTRACT scalar function.....	459
FLOAT scalar function.....	461
FLOOR scalar function.....	462

GENERATE_UNIQUE and GENERATE_UNIQUE_BINARY scalar functions.....	462
GETHINT scalar function.....	463
GETVARIABLE scalar function.....	464
GRAPHIC scalar function.....	465
GREATEST scalar function.....	470
HASH scalar function.....	471
HASH_CRC32, HASH_MD5, HASH_SHA1, and HASH_SHA256 scalar functions.....	472
HEX scalar function.....	474
HOUR scalar function.....	475
IDENTITY_VAL_LOCAL scalar function.....	476
IFNULL scalar function.....	479
INSERT scalar function.....	480
INSTR scalar function.....	482
INTEGER or INT scalar function.....	483
JULIAN_DAY.....	484
LAST_DAY scalar function.....	485
LCASE scalar function.....	486
LEAST scalar function.....	486
LEFT scalar function.....	487
LENGTH scalar function.....	489
LN scalar function.....	490
LOCATE scalar function.....	490
LOCATE_IN_STRING scalar function.....	493
LOG10 scalar function.....	494
LOWER scalar function.....	495
LPAD scalar function.....	498
LTRIM scalar function.....	500
MAX scalar function.....	501
MAX_CARDINALITY scalar function.....	502
MICROSECOND scalar function.....	503
MIDNIGHT_SECONDS scalar function.....	504
MIN scalar function.....	505
MINUTE scalar function.....	505
MOD scalar function.....	506
MONTH scalar function.....	508
MONTHS_BETWEEN scalar function.....	508
MQREAD scalar function.....	510
MQREADCLOB scalar function.....	511
MQRECEIVE scalar function.....	512
MQRECEIVECLOB scalar function.....	514
MQSEND scalar function.....	516
MULTIPLY_ALT scalar function.....	517
NEXT_DAY scalar function.....	518
NEXT_MONTH.....	520
NORMALIZE_DECFLOAT scalar function.....	520
NORMALIZE_STRING scalar function.....	521
NULLIF scalar function.....	522
NVL scalar function.....	523
OVERLAY scalar function.....	523
PACK scalar function.....	526
POSITION scalar function.....	529
POSSTR or STRPOS scalar function.....	532
POWER or POW scalar function.....	533
QUANTIZE scalar function.....	534
QUARTER scalar function.....	535
RADIANS scalar function.....	536
RAISE_ERROR scalar function.....	536
RANDOM or RAND scalar function.....	537

REAL scalar function.....	538
REGEXP_COUNT.....	539
REGEXP_INSTR.....	541
REGEXP_LIKE.....	543
REGEXP_REPLACE.....	546
REGEXP_SUBSTR.....	549
REPEAT scalar function.....	551
REPLACE scalar function.....	552
RID scalar function.....	555
RIGHT scalar function.....	556
ROUND scalar function.....	558
ROUND_TIMESTAMP scalar function.....	559
ROWID scalar function.....	563
RPAD scalar function.....	563
RTRIM scalar function.....	565
SCORE scalar function.....	566
SECOND scalar function.....	568
SIGN scalar function.....	570
SIN scalar function.....	570
SINH scalar function.....	571
SMALLINT scalar function.....	571
SOUNDEX scalar function.....	572
SOAPHTTPC and SOAPHTTPV scalar function.....	573
SOAPHTTPNC and SOAPHTTPNV scalar function.....	574
SPACE scalar function.....	575
SQRT scalar function.....	575
STRIP scalar function.....	576
STRLEFT scalar function.....	576
STRPOS scalar function.....	577
STRRIGHT scalar function.....	577
SUBSTR scalar function.....	577
SUBSTRING scalar function.....	579
TAN scalar function.....	583
TANH scalar function.....	583
TIME scalar function.....	584
TIMESTAMP scalar function.....	584
TIMESTAMPADD scalar function.....	587
TIMESTAMPDIFF scalar function.....	588
TIMESTAMP_FORMAT or TO_TIMESTAMP scalar function.....	591
TIMESTAMP_ISO scalar function.....	595
TIMESTAMP_TZ scalar function.....	596
TO_CHAR scalar function.....	598
TO_CLOB scalar function.....	598
TO_DATE scalar function.....	599
TO_NUMBER scalar function.....	599
TOTALORDER scalar function.....	599
TO_TIMESTAMP scalar function.....	600
TRANSLATE scalar function.....	600
TRIM scalar function.....	603
TRIM_ARRAY scalar function.....	605
TRUNCATE or TRUNC scalar function.....	606
TRUNC_TIMESTAMP scalar function.....	607
UCASE scalar function.....	610
UNICODE scalar function.....	610
UNICODE_STR or UNISTR scalar function.....	611
UPPER scalar function.....	612
VALUE scalar function.....	614
VARBINARY scalar function.....	614

VARCHAR scalar function.....	615
VARCHAR9 scalar function.....	620
VARCHAR_BIT_FORMAT scalar function.....	622
VARCHAR_FORMAT scalar function.....	623
VARGRAPHIC scalar function.....	632
VERIFY_GROUP_FOR_USER scalar function.....	637
VERIFY_ROLE_FOR_USER scalar function.....	638
VERIFY_TRUSTED_CONTEXT_ROLE_FOR_USER scalar function.....	640
WEEK scalar function.....	641
WEEK_ISO scalar function.....	642
WRAP scalar function.....	643
XMLATTRIBUTES scalar function.....	644
XMLCOMMENT scalar function.....	645
XMLCONCAT scalar function.....	645
XMLDOCUMENT scalar function.....	646
XMLELEMENT scalar function.....	647
XMLFOREST scalar function.....	651
XMLMODIFY scalar function.....	653
XMLNAMESPACES scalar function.....	656
XMLPARSE scalar function.....	657
XMLPI scalar function.....	659
XMLQUERY scalar function.....	659
XMLSERIALIZE scalar function.....	662
XMLTEXT scalar function.....	665
XMLXSROBJECTID scalar function.....	666
XSLTRANSFORM scalar function.....	667
YEAR scalar function.....	668
Table functions.....	669
ADMIN_TASK_LIST table function.....	669
ADMIN_TASK_OUTPUT table function.....	673
ADMIN_TASK_STATUS table function.....	675
BLOCKING_THREADS table function.....	678
MQREADALL table function.....	685
MQREADALLCLOB table function.....	687
MQRECEIVEALL table function.....	689
MQRECEIVEALLCLOB table function.....	691
XMLTABLE table function.....	693
Row functions.....	696
UNPACK row function.....	696

Chapter 5. Procedures that are supplied with Db2..... 699

ADMIN_COMMAND_DB2.....	699
ADMIN_COMMAND_DSN.....	712
ADMIN_COMMAND_MVS.....	714
ADMIN_COMMAND_UNIX.....	725
ADMIN_DS_BROWSE.....	729
ADMIN_DS_DELETE.....	732
ADMIN_DS_LIST.....	735
ADMIN_DS_RENAME.....	741
ADMIN_DS_SEARCH.....	744
ADMIN_DS_WRITE.....	747
ADMIN_EXPLAIN_MAINT.....	751
ADMIN_INFO_HOST.....	760
ADMIN_INFO_IFCID.....	763
ADMIN_INFO_SMS.....	766
ADMIN_INFO_SSID.....	770
ADMIN_INFO_SQL.....	771

ADMIN_INFO_SYSLOG.....	781
ADMIN_INFO_SYSPARM.....	784
ADMIN_JOB_CANCEL.....	788
ADMIN_JOB_FETCH.....	791
ADMIN_JOB_QUERY.....	794
ADMIN_JOB_SUBMIT.....	798
ADMIN_TASK_ADD.....	802
ADMIN_TASK_CANCEL.....	808
ADMIN_TASK_REMOVE.....	809
ADMIN_TASK_UPDATE.....	811
ADMIN_UPDATE_SYSPARM.....	814
ADMIN_UTL_EXECUTE.....	822
ADMIN_UTL_MONITOR.....	824
ADMIN_UTL_MODIFY.....	830
ADMIN_UTL_SCHEDULE.....	832
ADMIN_UTL_SORT.....	841
CREATE_WRAPPED.....	847
DSNACCOX.....	848
DSNACICS.....	880
DSNAIMS.....	885
DSNAIMS2.....	889
DSNLEUSR.....	893
DSNUTILS.....	895
DSNUTILU.....	906
DSNUTILV.....	910
DSN_WLM_APPENV.....	913
DSN8.CREATE_DGTT.....	916
DSN8.DISABLE.....	917
DSN8.ENABLE.....	918
DSN8.GET_LINE.....	919
DSN8.GET_LINES.....	920
DSN8.NEW_LINE.....	921
DSN8.PUT.....	921
DSN8.PUT_LINE.....	922
Objects that are used by the sample trace stored procedures.....	923
GET_CONFIG.....	923
GET_MESSAGE.....	942
GET_SYSTEM_INFO.....	949
SET_MAINT_MODE_RECORD_NO_TEMPORALHISTORY.....	962
SET_PLAN_HINT.....	962
SQLJ.ALTER_JAVA_PATH.....	988
SQLJ.DB2_INSTALL_JAR.....	991
SQLJ.DB2_REPLACE_JAR.....	992
SQLJ.INSTALL_JAR.....	994
SQLJ.REMOVE_JAR.....	995
SQLJ.REPLACE_JAR.....	996
WLM_REFRESH.....	997
WLM_SET_CLIENT_INFO.....	999
XSR_ADDSCHEMADOC.....	1000
XSR_COMPLETE.....	1002
XSR_REGISTER.....	1003
XSR_REMOVE.....	1005
Chapter 6. Queries.....	1007
Authorization.....	1007
subselect.....	1009
select-clause.....	1010

from-clause.....	1017
where-clause.....	1036
group-by-clause.....	1037
having-clause.....	1043
order-by-clause.....	1043
offset-clause.....	1046
fetch-clause.....	1047
Examples of subselects.....	1048
Examples of grouping sets, rollup, and cube queries.....	1054
fullselect.....	1060
Character conversion in set operations and concatenations.....	1066
Selecting the result CCSID.....	1066
select-statement.....	1067
common-table-expression.....	1069
update-clause.....	1071
read-only-clause.....	1072
optimize-clause.....	1073
isolation-clause.....	1073
queryno-clause.....	1075
SKIP LOCKED DATA.....	1076
Examples of SELECT statements.....	1077

Chapter 7. Statements..... 1079

List of supported statements.....	1079
How SQL statements are invoked.....	1086
Embedding a statement in an application program.....	1087
Dynamic preparation and execution.....	1088
Static invocation of a SELECT statement.....	1089
Dynamic invocation of a SELECT statement.....	1089
Interactive invocation.....	1090
SQL diagnostics information.....	1090
Detecting and processing error and warning conditions in host language applications.....	1091
SQL comments.....	1092
ALLOCATE CURSOR statement.....	1093
ALTER DATABASE statement.....	1095
ALTER FUNCTION statement (external function).....	1097
ALTER FUNCTION statement (compiled SQL scalar function).....	1113
ALTER FUNCTION statement (inlined SQL scalar function).....	1142
ALTER FUNCTION statement (SQL table function).....	1150
ALTER INDEX statement.....	1157
ALTER MASK statement.....	1174
ALTER PERMISSION statement.....	1177
ALTER PROCEDURE statement (external procedure).....	1180
ALTER PROCEDURE statement (SQL - external procedure) (deprecated).....	1189
ALTER PROCEDURE statement (SQL - native procedure).....	1194
ALTER SEQUENCE statement.....	1224
ALTER STOGROUP statement.....	1228
ALTER TABLE statement.....	1232
ALTER TABLESPACE statement.....	1321
ALTER TRIGGER statement (advanced trigger).....	1342
ALTER TRIGGER statement (basic trigger).....	1365
ALTER TRUSTED CONTEXT statement.....	1368
ALTER VIEW statement.....	1378
ASSOCIATE LOCATORS statement.....	1380
BEGIN DECLARE SECTION statement.....	1383
CALL statement.....	1384
CLOSE statement.....	1395

COMMENT statement.....	1396
COMMIT statement.....	1406
CONNECT statement.....	1409
CREATE ALIAS statement.....	1415
CREATE AUXILIARY TABLE statement.....	1418
CREATE DATABASE statement.....	1421
CREATE FUNCTION statement (overview).....	1424
CREATE FUNCTION statement (compiled SQL scalar function).....	1428
CREATE FUNCTION statement (external scalar function).....	1453
CREATE FUNCTION statement (external table function).....	1472
CREATE FUNCTION statement (inlined SQL scalar function).....	1489
CREATE FUNCTION statement (sourced function).....	1498
CREATE FUNCTION statement (SQL table function).....	1510
CREATE GLOBAL TEMPORARY TABLE statement.....	1518
CREATE INDEX statement.....	1524
CREATE LOB TABLESPACE.....	1553
CREATE MASK statement.....	1562
CREATE PERMISSION statement.....	1571
CREATE PROCEDURE statement (overview).....	1578
CREATE PROCEDURE statement (external procedure).....	1580
CREATE PROCEDURE statement (SQL - external procedure) (deprecated).....	1597
CREATE PROCEDURE statement (SQL - native procedure).....	1607
CREATE ROLE statement.....	1637
CREATE SEQUENCE statement.....	1638
CREATE STOGROUP statement.....	1645
CREATE SYNONYM statement (unsupported).....	1649
CREATE TABLE statement.....	1650
CREATE TABLESPACE statement.....	1718
CREATE TRIGGER statement (advanced trigger).....	1740
CREATE TRIGGER statement (basic trigger).....	1769
CREATE TRUSTED CONTEXT statement.....	1787
CREATE TYPE statement.....	1795
CREATE TYPE statement (array type).....	1795
CREATE TYPE statement (distinct type).....	1801
CREATE VARIABLE statement.....	1808
CREATE VIEW statement.....	1812
DECLARE CURSOR statement.....	1819
DECLARE GLOBAL TEMPORARY TABLE statement.....	1830
DECLARE STATEMENT statement.....	1844
DECLARE TABLE statement.....	1845
DECLARE VARIABLE statement.....	1850
DELETE statement.....	1853
DESCRIBE statement.....	1869
DESCRIBE CURSOR statement.....	1869
DESCRIBE INPUT statement.....	1871
DESCRIBE OUTPUT statement.....	1873
DESCRIBE PROCEDURE statement.....	1879
DESCRIBE TABLE statement.....	1881
DROP statement.....	1886
END DECLARE SECTION statement.....	1907
EXCHANGE statement.....	1908
EXECUTE statement.....	1909
EXECUTE IMMEDIATE statement.....	1914
EXPLAIN statement.....	1917
FETCH statement.....	1924
FREE LOCATOR statement.....	1949
GET DIAGNOSTICS statement.....	1949
GRANT statement.....	1963

GRANT statement (collection privileges).....	1967
GRANT statement (database privileges).....	1968
GRANT statement (function or procedure privileges).....	1970
GRANT statement (package privileges).....	1975
GRANT statement (plan privileges).....	1977
GRANT statement (schema privileges).....	1978
GRANT statement (sequence privileges).....	1979
GRANT statement (system privileges).....	1981
GRANT statement (table or view privileges).....	1988
GRANT statement (type or JAR file privileges).....	1991
GRANT statement (variable privileges).....	1992
GRANT statement (use privileges).....	1993
HOLD LOCATOR statement.....	1994
INCLUDE statement.....	1995
INSERT statement.....	1996
LABEL statement.....	2015
LOCK TABLE statement.....	2017
MERGE statement.....	2019
OPEN statement.....	2037
PREPARE statement.....	2042
REFRESH TABLE statement.....	2062
RELEASE statement (connection).....	2063
RELEASE SAVEPOINT statement.....	2065
RENAME statement.....	2066
REVOKE statement.....	2070
REVOKE statement (collection privileges).....	2076
REVOKE statement (database privileges).....	2078
REVOKE statement (function or procedure privileges).....	2081
REVOKE statement (package privileges).....	2087
REVOKE statement (plan privileges).....	2089
REVOKE statement (schema privileges).....	2091
REVOKE statement (sequence privileges).....	2093
REVOKE statement (system privileges).....	2095
REVOKE statement (table or view privileges).....	2101
REVOKE (type or JAR file privileges).....	2104
REVOKE (variable privileges).....	2106
REVOKE statement (use privileges).....	2108
ROLLBACK statement.....	2110
SAVEPOINT statement.....	2113
SELECT statement.....	2114
SELECT INTO statement.....	2117
SET CONNECTION statement.....	2122
SET <i>assignment-statement</i> statement.....	2124
SET CURRENT ACCELERATOR statement.....	2129
SET CURRENT APPLICATION COMPATIBILITY statement.....	2130
SET CURRENT APPLICATION ENCODING SCHEME.....	2132
SET CURRENT DEBUG MODE statement.....	2133
SET CURRENT DECFLOAT ROUNDING MODE statement.....	2134
SET CURRENT DEGREE statement.....	2136
SET CURRENT EXPLAIN MODE statement.....	2137
SET CURRENT GET_ACCEL_ARCHIVE statement.....	2138
SET CURRENT LOCALE LC_CTYPE statement.....	2139
SET CURRENT MAINTAINED TABLE TYPES FOR OPTIMIZATION statement.....	2141
SET CURRENT OPTIMIZATION HINT statement.....	2142
SET CURRENT PACKAGE PATH statement.....	2143
SET CURRENT PACKAGESET statement.....	2146
SET CURRENT PRECISION statement.....	2148
SET CURRENT QUERY ACCELERATION statement.....	2148

SET CURRENT QUERY ACCELERATION WAITFORDATA statement.....	2150
SET CURRENT REFRESH AGE statement.....	2153
SET CURRENT ROUTINE VERSION statement.....	2154
SET CURRENT RULES statement.....	2156
SET CURRENT SQLID statement.....	2156
SET CURRENT TEMPORAL BUSINESS_TIME statement.....	2158
SET CURRENT TEMPORAL SYSTEM_TIME statement.....	2160
SET ENCRYPTION PASSWORD statement.....	2161
SET PATH statement.....	2163
SET SCHEMA statement.....	2166
SET SESSION TIME ZONE statement.....	2168
SIGNAL statement.....	2169
TRANSFER OWNERSHIP statement.....	2172
TRUNCATE statement.....	2175
UPDATE statement.....	2178
VALUES statement.....	2199
VALUES INTO statement.....	2200
WHENEVER statement.....	2204

Chapter 8. SQL procedural language (SQL PL)..... 2207

References to SQL parameters and variables in SQL PL.....	2208
References to SQL condition names.....	2209
References to SQL cursor names.....	2210
References to SQL labels.....	2210
References to SQL statement names.....	2210
Summary of name scoping in nested compound statements.....	2210
SQL-procedure-statement (SQL PL).....	2212
assignment-statement.....	2217
CALL statement.....	2218
CASE statement.....	2219
compound-statement.....	2221
FOR statement.....	2229
GET DIAGNOSTICS statement.....	2230
GOTO statement.....	2231
IF statement.....	2232
ITERATE statement.....	2233
LEAVE statement.....	2234
LOOP statement.....	2236
REPEAT statement.....	2237
RESIGNAL statement.....	2238
RETURN statement.....	2240
SIGNAL statement.....	2242
WHILE statement.....	2245

Appendix A. Limits in Db2 for z/OS..... 2247

Appendix B. Reserved schema names and reserved words in Db2 for z/OS..... 2257

Reserved schema names in Db2 for z/OS.....	2257
Reserved words in Db2 for z/OS.....	2258

Appendix C. Actions allowed on SQL statements.....2269

Appendix D. SQL statement data access classification for routines..... 2275

Appendix E. SQL control statements for external SQL procedures.....2279

References to SQL parameters and SQL variables in external SQL procedures.....	2280
--	------

SQL-procedure-statement (external).....	2280
assignment-statement (SQL control statements for external routines).....	2281
CALL statement.....	2282
CASE statement.....	2284
compound-statement.....	2286
GET DIAGNOSTICS statement.....	2290
GOTO statement.....	2290
IF statement.....	2292
ITERATE statement.....	2293
LEAVE statement.....	2293
LOOP statement.....	2294
REPEAT statement.....	2295
RESIGNAL statement.....	2296
RETURN statement.....	2298
SIGNAL statement.....	2299
WHILE statement.....	2302
Appendix F. SQL communication area (SQLCA).....	2303
Description of SQLCA fields.....	2303
The included SQLCA.....	2308
The REXX SQLCA.....	2310
Appendix G. SQL descriptor area (SQLDA).....	2313
Description of SQLDA fields.....	2313
The SQLDA Header.....	2314
SQLVAR entries.....	2315
Unrecognized and unsupported SQLTYPES.....	2325
The included SQLDA.....	2326
Identifying an SQLDA in C or C++.....	2329
The REXX SQLDA.....	2329
Appendix H. Db2 catalog tables.....	2333
IPLIST catalog table.....	2348
IPNAMES catalog table.....	2349
LOCATIONS catalog table.....	2351
LULIST catalog table.....	2353
LUMODES catalog table.....	2353
LUNAMES catalog table.....	2354
MODESELECT catalog table.....	2358
SYSAUDITPOLICIES catalog table.....	2358
SYSAUTOALERTS catalog table.....	2364
SYSAUTOALERTS_OUT catalog table.....	2365
SYSAUTORUNS_HIST catalog table.....	2366
SYSAUTORUNS_HISTOU catalog table.....	2366
SYSAUTOTIMEWINDOWS catalog table.....	2367
SYSAUXRELS catalog table.....	2368
SYSCHECKDEP catalog table.....	2369
SYSCHECKS catalog table.....	2369
SYSCHECKS2 catalog table.....	2370
SYSCOLAUTH catalog table.....	2371
SYSCOLDIST catalog table.....	2373
SYSCOLDISTSTATS catalog table.....	2375
SYSCOLDIST_HIST catalog table.....	2377
SYSCOLSTATS catalog table.....	2379
SYSCOLUMNS catalog table.....	2381
SYSCOLUMNS_HIST catalog table.....	2395
SYSCONSTDEP catalog table.....	2400

SYSCONTEXT catalog table.....	2401
SYSCONTEXTAUTHIDS catalog table.....	2404
SYSCONTROLS catalog table.....	2405
SYSCOPY catalog table.....	2408
SYSCTXTTRUSTATTRS catalog table.....	2426
SYSDATABASE catalog table.....	2427
SYSDATATYPES catalog table.....	2429
SYSDBAUTH catalog table.....	2432
SYSDBRM catalog table.....	2437
SYSDEPENDENCIES catalog table.....	2439
SYSDUMMY1 catalog table.....	2443
SYSDUMMYA catalog table.....	2443
SYSDUMMYE catalog table.....	2444
SYSDUMMYU catalog table.....	2444
SYSDYNQRY catalog table.....	2444
SYSDYNQRYDEP catalog table.....	2446
SYSDYNQRY_EXPL catalog table.....	2451
SYSDYNQRY_OPL catalog table.....	2451
SYSDYNQRY_SHTEL catalog table.....	2451
SYSDYNQRY_SPAL catalog table.....	2451
SYSDYNQRY_TXTL catalog table.....	2451
SYSENVIRONMENT catalog table.....	2452
SYSFIELDS catalog table.....	2456
SYSFOREIGNKEYS catalog table.....	2458
SYSINDEXCLEANUP catalog table.....	2458
SYSINDEXCONTROL catalog table.....	2460
SYSINDEXES catalog table.....	2461
SYSINDEXES_HIST catalog table.....	2472
SYSINDEXES_RTSECT catalog table.....	2474
SYSINDEXES_TREE catalog table.....	2474
SYSINDEXPART catalog table.....	2474
SYSINDEXPART_HIST catalog table.....	2480
SYSINDEXSPACESTATS catalog table.....	2482
SYSINDEXSTATS catalog table.....	2490
SYSINDEXSTATS_HIST catalog table.....	2492
SYSJARCLASS_SOURCE catalog table.....	2494
SYSJARCONTENTS catalog table.....	2494
SYSJARDATA catalog table.....	2495
SYSJAROBJECTS catalog table.....	2495
SYSJAVA_OPTS catalog table.....	2496
SYSJAVAPATHS catalog table.....	2497
SYSKEYCOLUSE catalog table.....	2497
SYSKEYS catalog table.....	2498
SYSKEYTARGETS catalog table.....	2500
SYSKEYTARGETSTATS catalog table.....	2503
SYSKEYTARGETS_HIST catalog table.....	2505
SYSKEYTGTDIST catalog table.....	2509
SYSKEYTGTDISTSTATS catalog table.....	2511
SYSKEYTGTDIST_HIST catalog table.....	2513
SYSLEVELUPDATES catalog table.....	2515
SYSLOBSTATS catalog table.....	2516
SYSLOBSTATS_HIST catalog table.....	2516
SYSOBJROLEDEP catalog table.....	2517
SYSPACKAGE catalog table.....	2519
SYSPACKAUTH catalog table.....	2536
SYSPACKCOPY catalog table.....	2538
SYSPACKDEP catalog table.....	2554
SYSPACKLIST catalog table.....	2558

SYSPACKSTMT catalog table.....	2558
SYSPACKSTMT_STMB catalog table.....	2565
SYSPACKSTMT_STMT catalog table.....	2565
SYSPARMS catalog table.....	2565
SYSPENDINGDDL catalog table.....	2570
SYSPENDINGOBJECTS catalog table.....	2572
SYSPKSYSTEM catalog table.....	2574
SYSPLAN catalog table.....	2575
SYSPLANAUTH catalog table.....	2582
SYSPLANDEP catalog table.....	2584
SYSPLSYSTEM catalog table.....	2586
SYSQUERY catalog table.....	2587
SYSQUERYOPTS catalog table.....	2590
SYSQUERYPLAN catalog table.....	2592
SYSQUERYPREDICATE catalog table.....	2606
SYSQUERYSEL catalog table.....	2611
SYSQUERY_AUX catalog table.....	2613
SYSRELS catalog table.....	2613
SYSRESAUTH catalog table.....	2615
SYSROLES catalog table.....	2618
SYSROUTINEAUTH catalog table.....	2619
SYSROUTINES catalog table.....	2621
SYSROUTINESTEXT catalog table.....	2635
SYSROUTINES_OPTS catalog table (deprecated).....	2635
SYSROUTINES_TREE catalog table.....	2637
SYSROUTINES_SRC catalog table (deprecated).....	2637
SYSSCHEMAAUTH catalog table.....	2638
SYSSEQUENCEAUTH catalog table.....	2640
SYSSEQUENCES catalog table.....	2643
SYSSEQUENCESDEP catalog table.....	2646
SYSSESSION catalog table.....	2647
SYSSESSION_EX catalog table.....	2648
SYSSESSION_STATUS catalog table.....	2648
SYSSTATFEEDBACK catalog table.....	2649
SYSSTMT catalog table.....	2651
SYSSTOGROUP catalog table.....	2655
SYSSTRINGS catalog table.....	2656
SYSSYNONYMS catalog table.....	2658
SYSTABAUTH catalog table.....	2659
SYSTABCONST catalog table.....	2664
SYSTABLEPART catalog table.....	2665
SYSTABLEPART_HIST catalog table.....	2675
SYSTABLES catalog table.....	2678
SYSTABLESPACE catalog table.....	2688
SYSTABLESPACESTATS catalog table.....	2699
SYSTABLES_HIST catalog table.....	2707
SYSTABLES_PROFILES catalog table.....	2709
SYSTABLES_PROFILE_TEXT catalog table.....	2710
SYSTABSTATS catalog table.....	2710
SYSTABSTATS_HIST catalog table.....	2711
SYSTRIGGERS catalog table.....	2712
SYSTRIGGERS_STMT catalog table.....	2715
SYSUSERAUTH catalog table.....	2715
SYSVARIABLEAUTH catalog table.....	2722
SYSVARIABLES catalog table.....	2724
SYSVARIABLES_DESC catalog table.....	2728
SYSVARIABLES_TEXT catalog table.....	2728
SYSVIEWDEP catalog table.....	2729

SYSVIEWS catalog table.....	2730
SYSVIEWS_STMT catalog table.....	2733
SYSVIEWS_TREE catalog table.....	2733
SYSVOLUMES catalog table.....	2733
SYSXMLRELS catalog table.....	2734
SYSXMLSTRINGS catalog table.....	2735
SYSXMLTYPMOD catalog table.....	2735
SYSXMLTYPMSCHEMA catalog table.....	2736
USERNAMES table.....	2737
Reorganizing the catalog.....	2738
SQL statements allowed on the catalog.....	2739
Temporal versioning for Db2 catalog tables.....	2742
Temporal versioning for Db2 statistics-related catalog tables.....	2742
Catalog indexes.....	2744

Appendix I. Db2 directory tables.....2769

Appendix J. Performance information for SQL application programming.....2777

Appendix K. Db2 XML schema repository tables..... 2779

XML schema repository (XSR) table spaces and indexes.....	2779
XSRANNOTATIONINFO table.....	2780
XSRCOMPONENT table.....	2781
XSROBJECTS table.....	2782
XSROBJECTCOMPONENTS table.....	2783
XSROBJECTGRAMMAR table.....	2784
XSROBJECTHIERARCHIES table.....	2784
XSROBJECTPROPERTY table.....	2785
XSRPROPERTY table.....	2785

Appendix L. EXPLAIN tables..... 2787

PLAN_TABLE.....	2787
DSN_COLDIST_TABLE.....	2809
DSN_DETCOST_TABLE.....	2817
DSN_FILTER_TABLE.....	2827
DSN_FUNCTION_TABLE.....	2832
DSN_KEYTGTDIST_TABLE.....	2837
DSN_PGRANGE_TABLE.....	2844
DSN_PGROUPTABLE.....	2848
DSN_PREDICAT_TABLE.....	2855
DSN_PREDICATE_SELECTIVITY table.....	2863
DSN_PTASK_TABLE.....	2869
DSN_QUERYINFO_TABLE.....	2874
DSN_QUERY_TABLE.....	2882
DSN_SORTKEY_TABLE.....	2885
DSN_SORT_TABLE.....	2891
DSN_STATEMENT_CACHE_TABLE.....	2896
DSN_STATEMNT_TABLE.....	2906
DSN_STAT_FEEDBACK.....	2915
DSN_STRUCT_TABLE.....	2920
DSN_VIEWREF_TABLE.....	2926

Appendix M. Tables that support query acceleration..... 2931

SYSACCEL.SYSACCELERATORS table.....	2931
SYSACCEL.SYSACCELERATEDTABLES table.....	2932
SYSACCEL.SYSACCELERATEDTABLESAUTH table.....	2934
SYSACCEL.SYSACCELERATEDPACKAGES table.....	2934

Appendix N. Tables that are used for program authorization.....	2939
Table spaces and indexes for program authorization.....	2939
SYSIBM.DSNPROGAUTH table.....	2939
Appendix O. Sample user-defined functions.....	2941
ALTDATE.....	2941
ALTTIME.....	2943
BASE64ENCODE and BASE64DECODE.....	2945
CURRENCY.....	2945
DAYNAME.....	2946
HDFS_READ.....	2947
HTTPBLOB.....	2948
HTTPCLOB.....	2949
HTTPDELETEBLOB and HTTPDELETECLOB.....	2950
HTTPGETBLOB and HTTPGETCLOB.....	2952
HTTPGETBLOBFILE and HTTPGETCLOBFILE.....	2954
HTTPHEAD.....	2955
HTTPPOSTBLOB and HTTPPOSTCLOB.....	2956
HTTPPUTBLOB and HTTPPUTCLOB.....	2957
JAQL_SUBMIT.....	2958
MONTHNAME.....	2959
TABLE_LOCATION.....	2960
TABLE_NAME.....	2961
TABLE_SCHEMA.....	2962
URLENCODE and URLDECODE.....	2963
WEATHER.....	2964
Information resources for Db2 for z/OS and related products.....	2967
Notices.....	2969
Programming interface information.....	2970
Trademarks.....	2970
Terms and conditions for product documentation.....	2971
Privacy policy considerations.....	2971
Glossary.....	2973
Index.....	2975

About this information

This book is a reference for Structured Query Language (SQL) for Db2 for z/OS, including the SQL procedural language (SQL PL). Unless otherwise stated, references to SQL in this book imply SQL for Db2 for z/OS, and all objects described in this book are objects of Db2 for z/OS.

The syntax and semantics of most SQL statements are essentially the same in all IBM® relational database products, and the language elements common to the products provide a base for the definition of IBM SQL. Consult *IBM DB2 SQL Reference for Cross-Platform Development* if you intend to develop applications that adhere to IBM SQL.

Throughout this information, "Db2" means "Db2 12 for z/OS". References to other Db2 products use complete names or specific abbreviations.

Important: To find the most up to date content for Db2 12 for z/OS, always use [IBM Documentation](#) or download the latest PDF file from [PDF format manuals for Db2 12 for z/OS \(Db2 for z/OS in IBM Documentation\)](#).

Most documentation topics for Db2 12 for z/OS assume that the highest available function level is activated and that your applications are running with the highest available application compatibility level, with the following exceptions:

- The following documentation sections describe the Db2 12 migration process and how to activate new capabilities in function levels:
 - [Migrating to Db2 12 \(Db2 Installation and Migration\)](#)
 - [What's new in Db2 12 \(Db2 for z/OS What's New?\)](#)
 - [Adopting new capabilities in Db2 12 continuous delivery \(Db2 for z/OS What's New?\)](#)
- [FL 501 A](#) label like this one usually marks documentation changed for function level 500 or higher, with a link to the description of the function level that introduces the change in Db2 12. For more information, see [How Db2 function levels are documented \(Db2 for z/OS What's New?\)](#).

The availability of new function depends on the type of enhancement, the activated function level, and the application compatibility levels of applications. In the initial Db2 12 release, most new capabilities are enabled only after the activation of function level 500 or higher.

Virtual storage enhancements

Virtual storage enhancements become available at the activation of the function level that introduces them or higher. Activation of function level 100 introduces all virtual storage enhancements in the initial Db2 12 release. That is, activation of function level 500 introduces no virtual storage enhancements.

Subsystem parameters

New subsystem parameter settings are in effect only when the function level that introduced them or a higher function level is activated. Many subsystem parameter changes in the initial Db2 12 release take effect in function level 500. For more information about subsystem parameter changes in Db2 12, see [Subsystem parameter changes in Db2 12 \(Db2 for z/OS What's New?\)](#).

Optimization enhancements

Optimization enhancements become available after the activation of the function level that introduces them or higher, and full prepare of the SQL statements. When a full prepare occurs depends on the statement type:

- For static SQL statements, after bind or rebind of the package
- For non-stabilized dynamic SQL statements, immediately, unless the statement is in the dynamic statement cache
- For stabilized dynamic SQL statements, after invalidation, free, or changed application compatibility level

Activation of function level 100 introduces all optimization enhancements in the initial Db2 12 release. That is, function level 500 introduces no optimization enhancements.

SQL capabilities

New SQL capabilities become available after the activation of the function level that introduces them or higher, for applications that run at the equivalent application compatibility level or higher. New SQL capabilities in the initial Db2 12 release become available in function level 500 for applications that run at the equivalent application compatibility level or higher. You can continue to run SQL statements compatibly with lower function levels, or previous Db2 releases, including Db2 11 and DB2® 10. For details, see [Application compatibility levels in Db2 12 \(Db2 Application programming and SQL\)](#)

Who should read this information

This information is intended for end users, application programmers, system and database administrators, and for persons involved in error detection and diagnosis.

This information is a reference rather than a tutorial. It assumes that you are already familiar with SQL programming concepts.

When you first use this information, consider reading Chapters 1 and 2 sequentially. These chapters describe the basic concepts of relational databases and SQL, the basic syntax of SQL, and the language elements that are common to many SQL statements. The rest of the chapters and appendixes are designed for the quick location of answers to specific SQL questions. They provide you with query forms, SQL statements, SQL procedure statements, Db2 limits, SQLCA, SQLDA, catalog tables, and SQL reserved words.

Db2 Utilities Suite for z/OS

Important: Db2 Utilities Suite for z/OS is available as an optional product. You must separately order and purchase a license to such utilities, and discussion of those utility functions in this publication is not intended to otherwise imply that you have a license to them.

Db2 12 utilities can use the DFSORT program regardless of whether you purchased a license for DFSORT on your system. For more information about DFSORT, see <https://www.ibm.com/support/pages/dfsor>.

Db2 utilities can use IBM Db2 Sort for z/OS as an alternative to DFSORT for utility SORT and MERGE functions. Use of Db2 Sort for z/OS requires the purchase of a Db2 Sort for z/OS license. For more information about Db2 Sort for z/OS, see [Db2 Sort for z/OS documentation](#).

Related concepts

[Db2 utilities packaging \(Db2 Utilities\)](#)

Terminology and citations

When referring to a Db2 product other than Db2 for z/OS, this information uses the product's full name to avoid ambiguity.

The following terms are used as indicated:

Db2

Represents either the Db2 licensed program or a particular Db2 subsystem.

IBM rebranded DB2 to Db2, and Db2 for z/OS is the new name of the offering that was previously known as "DB2 for z/OS". For more information, see [Revised naming for IBM Db2 family products on IBM z/OS platform](#). As a result, you might sometimes still see references to the original names, such as "DB2 for z/OS" and "DB2", in different IBM web pages and documents. If the PID, Entitlement Entity, version, modification, and release information match, assume that they refer to the same product.

IBM OMEGAMON® for Db2 Performance Expert on z/OS

Refers to any of the following products:

- IBM OMEGAMON for Db2 Performance Expert on z/OS

- IBM Db2 Performance Monitor on z/OS
- IBM Db2 Performance Expert for Multiplatforms and Workgroups
- IBM Db2 Buffer Pool Analyzer for z/OS

C, C++, and C language

Represent the C or C++ programming language.

CICS®

Represents CICS Transaction Server for z/OS.

IMS

Represents the IMS Database Manager or IMS Transaction Manager.

MVS™

Represents the MVS element of the z/OS operating system, which is equivalent to the Base Control Program (BCP) component of the z/OS operating system.

RACF®

Represents the functions that are provided by the RACF component of the z/OS Security Server.

Accessibility features for Db2 for z/OS

Accessibility features help a user who has a physical disability, such as restricted mobility or limited vision, to use information technology products successfully.

Accessibility features

The following list includes the major accessibility features in z/OS products, including Db2 for z/OS. These features support:

- Keyboard-only operation.
- Interfaces that are commonly used by screen readers and screen magnifiers.
- Customization of display attributes such as color, contrast, and font size

Tip: [IBM Documentation](#) (which includes information for Db2 for z/OS) and its related publications are accessibility-enabled for the IBM Home Page Reader. You can operate all features using the keyboard instead of the mouse.

Keyboard navigation

For information about navigating the Db2 for z/OS ISPF panels using TSO/E or ISPF, refer to the *z/OS TSO/E Primer*, the *z/OS TSO/E User's Guide*, and the *z/OS ISPF User's Guide*. These guides describe how to navigate each interface, including the use of keyboard shortcuts or function keys (PF keys). Each guide includes the default settings for the PF keys and explains how to modify their functions.

Related accessibility information

IBM and accessibility

See the *IBM Accessibility Center* at <http://www.ibm.com/able> for more information about the commitment that IBM has to accessibility.

How to send your comments about Db2 for z/OS documentation

Your feedback helps IBM to provide quality documentation.

Send any comments about Db2 for z/OS and related product documentation by email to db2zinfo@us.ibm.com.

To help us respond to your comment, include the following information in your email:

- The product name and version
- The address (URL) of the page, for comments about online documentation
- The book name and publication date, for comments about PDF manuals
- The topic or section title
- The specific text that you are commenting about and your comment

Related concepts

[About Db2 12 for z/OS product documentation \(Db2 for z/OS in IBM Documentation\)](#)

Related reference

[PDF format manuals for Db2 12 for z/OS \(Db2 for z/OS in IBM Documentation\)](#)

How to read syntax diagrams

Certain conventions apply to the syntax diagrams that are used in IBM documentation.

Apply the following rules when reading the syntax diagrams that are used in Db2 for z/OS documentation:

- Read the syntax diagrams from left to right, from top to bottom, following the path of the line.

The $\blacktriangleright\blacktriangleright$ — symbol indicates the beginning of a statement.

The — \blacktriangleright symbol indicates that the statement syntax is continued on the next line.

The \blacktriangleright — symbol indicates that a statement is continued from the previous line.

The — $\blacktriangleright\blacktriangleleft$ symbol indicates the end of a statement.

- Required items appear on the horizontal line (the main path).

$\blacktriangleright\blacktriangleright$ *required_item* $\blacktriangleleft\blacktriangleleft$

- Optional items appear below the main path.

$\blacktriangleright\blacktriangleright$ *required_item* — *optional_item* $\blacktriangleleft\blacktriangleleft$

If an optional item appears above the main path, that item has no effect on the execution of the statement and is used only for readability.

$\blacktriangleright\blacktriangleright$ *required_item* — *optional_item* $\blacktriangleleft\blacktriangleleft$

- If you can choose from two or more items, they appear vertically, in a stack.

If you *must* choose one of the items, one item of the stack appears on the main path.

$\blacktriangleright\blacktriangleright$ *required_item* — *required_choice1* $\blacktriangleleft\blacktriangleleft$
required_choice2

If choosing one of the items is optional, the entire stack appears below the main path.

$\blacktriangleright\blacktriangleright$ *required_item* — *optional_choice1* $\blacktriangleleft\blacktriangleleft$
optional_choice2

If one of the items is the default, it appears above the main path and the remaining choices are shown below.

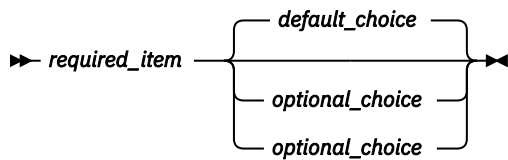

- An arrow returning to the left, above the main line, indicates an item that can be repeated.

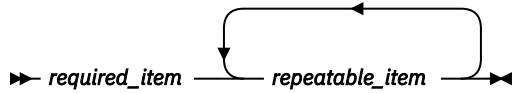

If the repeat arrow contains a comma, you must separate repeated items with a comma.

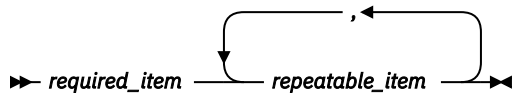

A repeat arrow above a stack indicates that you can repeat the items in the stack.

- Sometimes a diagram must be split into fragments. The syntax fragment is shown separately from the main syntax diagram, but the contents of the fragment should be read as if they are on the main path of the diagram.

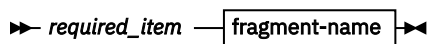

fragment-name

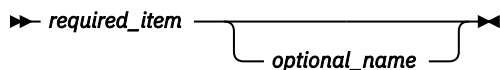

- For some references in syntax diagrams, you must follow any rules described in the description for that diagram, and also rules that are described in other syntax diagrams. For example:
 - For *expression*, you must also follow the rules described in [“Expressions”](#) on page 245.
 - For references to *fullselect*, you must also follow the rules described in [“fullselect”](#) on page 1060.
 - For references to *search-condition*, you must also follow the rules described in [“Search conditions”](#) on page 319.
- With the exception of XPath keywords, keywords appear in uppercase (for example, FROM). Keywords must be spelled exactly as shown.
- XPath keywords are defined as lowercase names, and must be spelled exactly as shown.
- Variables appear in all lowercase letters (for example, *column-name*). They represent user-supplied names or values.
- If punctuation marks, parentheses, arithmetic operators, or other such symbols are shown, you must enter them as part of the syntax.

Related concepts

[Commands in Db2 \(Db2 Commands\)](#)

[Db2 online utilities \(Db2 Utilities\)](#)

[Db2 stand-alone utilities \(Db2 Utilities\)](#)

Conventions for describing mixed data values

When mixed data values are shown in examples, certain conventions are used to represent these values.

At sites using a double-byte character set (DBCS), character strings can include a mixture of single-byte and double-byte characters. When mixed data values are shown in the examples, the conventions shown in the following example apply:

Convention	Representation
S _O	"shift-out" control character (X'0E"), used only for EBCDIC data
S _I	"shift-in" control character (X'0E"), used only for EBCDIC data
sbc-string	SBCS string of zero or more single-byte characters
dbc-string	DBCS string of zero or more double-byte characters
’	DBCS apostrophe
G	DBCS uppercase G

Figure 1. Conventions used when mixed data values are shown in examples

Industry standards for SQL

Db2 for z/OS conforms to the following industry standards for SQL:

- *ISO/IEC FCD 9075-1:2016, Information technology - Database languages - SQL - Part 1: Framework (SQL/Framework)*
- *ISO/IEC FCD 9075-2:2016, Information technology - Database languages - SQL - Part 2: Foundation (SQL/Foundation)*
- *ISO/IEC FCD 9075-3:2016, Information technology - Database languages - SQL - Part 3: Call-Level Interface (SQL/CLI)*
- *ISO/IEC FCD 9075-4:2016, Information technology - Database languages - SQL - Part 4: Persistent Stored Modules (SQL/PSM)*
- *ISO/IEC FCD 9075-10:2016, Information technology - Database languages - SQL - Part 10: Object Language Bindings (SQL/OLB)*
- *ISO/IEC FCD 9075-11:2016, Information technology - Database languages - SQL - Part 11: Information and Definition Schemas (SQL/Schemata)*
- *ISO/IEC FCD 9075-13:2016, Information technology - Database languages - SQL - Part 13: Java Routines and Types (SQL/JRT)*
- *ISO/IEC FCD 9075-14:2016, Information technology - Database languages - SQL - Part 14: XML-Related Specifications (SQL/XML)*

Chapter 1. Db2 for z/OS and SQL concepts

Many structures and processes are associated with a relational database. The structures are the key components of a Db2 database system, and the processes are the interactions that occur when applications access the database system.

In a relational database, data is perceived to exist in one or more *tables*. Each table contains a specific number of *columns* and a number of unordered *rows*. Each column in a table is related in some way to the other columns. Thinking of the data as a collection of tables gives you an easy way to visualize the data that is stored in a Db2 database.

Tables are at the core of a Db2 database. However, a Db2 database involves more than just a collection of tables; a Db2 database also involves other objects, such as views and indexes, and larger data containers, such as table spaces.

With Db2 for z/OS and the other Db2 products, you can define and manipulate your data by using structured query language (SQL). SQL is the standard language for accessing data in relational databases.

Submitting SQL statements to Db2

You can use several different methods to send SQL statements to Db2 in several ways.

You can issue SQL statements from interactively from a keyboard at a terminal or through a terminal emulator.

Another way to issue SQL statements is through application programs. The programs can contain SQL statements that are statically embedded in the application. Alternatively, application programs can create their SQL statements dynamically, for example, in response to information that a user provides by filling in a form.

The method of preparing an SQL statement for execution and the persistence of its operational form distinguish static SQL from dynamic SQL.

Related concepts

[How SQL statements are invoked](#)

SQL statements are invoked in different ways depending on whether the statement is an executable or nonexecutable statement or the *select-statement*.

Related tasks

[Overview of programming applications that access Db2 for z/OS data \(Db2 Application programming and SQL\)](#)

Static SQL

The source form of a *static SQL statement* is embedded within an application program written in a host language such as COBOL. The statement is prepared before the program is executed and the operational form of the statement persists beyond the execution of the program.

Static SQL statements in a source program must be processed before the program is compiled. This processing can be accomplished through the Db2 coprocessor or Db2 precompiler. The Db2 coprocessor or Db2 precompiler checks the syntax of the SQL statements, turns them into host language comments, and generates host language statements to invoke Db2.

The preparation of an SQL application program includes processing of the SQL statements, the preparation of its static SQL statements, and compilation of the modified source program.

Related concepts

[Static SQL applications \(Introduction to Db2 for z/OS\)](#)

[How SQL statements are invoked](#)

SQL statements are invoked in different ways depending on whether the statement is an executable or nonexecutable statement or the *select-statement*.

Related tasks

[Overview of programming applications that access Db2 for z/OS data \(Db2 Application programming and SQL\)](#)

[Processing SQL statements for program preparation \(Db2 Application programming and SQL\)](#)

Embedded dynamic SQL

Programs that contain *embedded dynamic SQL* statements must be precompiled like those that contain static SQL, but unlike static SQL, the dynamic statements are constructed and prepared at run time.

The source form of a dynamic statement is a character string that is passed to Db2 by the program using the static SQL PREPARE or EXECUTE IMMEDIATE statement. A statement that is prepared using the PREPARE statement can be referenced in a DECLARE CURSOR, DESCRIBE, or EXECUTE statement. Whether the operational form of the statement is persistent depends on whether dynamic statement caching is enabled.

SQL statements embedded in a REXX application are dynamic SQL statements. SQL statements submitted to an interactive SQL facility and to the CALL Level Interface (CLI) are also dynamic SQL.

Related concepts

[Embedding a statement in an application program](#)

You can include SQL statements in a source program that will be submitted to the Db2 precompiler or coprocessor. Such statements are said to be *embedded* in the application program. An embedded statement can be placed anywhere in the application program where a host language statement is allowed. Each embedded statement must be preceded by a keyword (or keywords) to indicate that the statement is an SQL statement.

[Dynamic preparation and execution](#)

Your application program can dynamically build an SQL statement in the form of a character string placed in a host variable. In general, the statement is built from some data available to the application program (for example, input from a workstation).

[Dynamic SQL applications \(Introduction to Db2 for z/OS\)](#)

[Embedded dynamic SQL \(Introduction to Db2 for z/OS\)](#)

Related tasks

[Including dynamic SQL in your program \(Db2 Application programming and SQL\)](#)

Deferred embedded SQL

A *deferred embedded* SQL statement is neither fully static nor fully dynamic.

Like a static statement, it is embedded within an application, but like a dynamic statement, it is prepared during the execution of the application. Although prepared at run time, a deferred embedded SQL statement is processed with bind-time rules such that the authorization ID and qualifier determined at bind time for the plan or package owner are used.

Interactive SQL

Interactive SQL refers to SQL statements that you submit to Db2 by using SPUFI (SQL processor using file input), the command line processor, or by using a query tool, such as QMF for Workstation.

The easiest and most efficient way to run SQL is to use a query tool. QMF for Workstation is a popular query tool that lets you enter and run your SQL statements easily. This topic acquaints you with using QMF for Workstation to create and run SQL statements. QMF for Workstation simplifies access to Db2 from a workstation. In fact, was QMF for Workstation built for Db2.

Although this topic focuses on QMF for Workstation, other options are available. You can use QMF for WebSphere® to enter and run SQL statements from your web browser or use QMF for TSO/CICS to enter and run SQL statements from TSO or CICS. In addition, you can enter and run SQL statements at a TSO

terminal by using the SPUFI (SQL processor using file input) facility. SPUFI prepares and executes these statements dynamically. All of these tools prepare and dynamically execute the SQL statements.

The Db2 Query Management Facility (QMF) family of technologies establish pervasive production and sharing of business intelligence for information-oriented tasks in the organization. QMF offers many strengths, including the following:

- Support for functionality in the Db2 database, including long names, Unicode, and SQL enhancements
- Drag-and-drop capability for building OLAP analytics, SQL queries, pivot tables, and other business analysis and reports
- Executive dashboards and data visual solutions that offer visually rich, interactive functionality and interfaces for data analysis
- Support for QMF for WebSphere, a tool that turns any web browser into a zero-maintenance, thin client for visual on demand access to enterprise Db2 data
- Re-engineered cross-platform development environment
- New security model for access control and personalization

The visual solutions previously provided by QMF Vision are now included in the core QMF technology.

In addition to QMF for Workstation, which this topic describes, the QMF family includes the following editions:

- QMF Enterprise Edition provides the entire QMF family of technologies, enabling enterprise-wide business information across user and database operating systems. This edition consists of:
 - QMF for TSO/CICS
 - QMF High Performance Option
 - QMF for Workstation
 - QMF for WebSphere
 - DataQuant for Workstation
 - DataQuant for WebSphere
- QMF Classic Edition supports users who work with traditional mainframe terminals and emulators (including WebSphere Host On Demand) to access Db2 databases. This edition consists of QMF for TSO/CICS.

Related concepts

[Interactive invocation](#)

An SQL statement submitted to Db2 from a terminal is said to be issued interactively.

[The Db2 command line processor \(Db2 Commands\)](#)

[Use of QMF for Workstation \(Introduction to Db2 for z/OS\)](#)

Related tasks

[Executing SQL by using SPUFI \(Db2 Application programming and SQL\)](#)

SQL Call Level Interface and Open Database Connectivity

The Db2 Call Level Interface (CLI) is an application programming interface in which functions are provided to application programs to process dynamic SQL statements.

Db2 CLI allows users to access SQL functions directly through a call interface. CLI programs can also be compiled using an Open Database Connectivity (ODBC) Software Developer's Kit, available from Microsoft or other vendors, enabling access to ODBC data sources. Unlike using embedded SQL, no precompilation is required. Applications developed using this interface can be executed on a variety of databases without being compiled against each of databases. Through the interface, applications use procedure calls at execution time to connect to databases, to issue SQL statements, and to get returned data and status information.

Related concepts

[Introduction to Db2 ODBC \(Db2 Programming for ODBC\)](#)

[Conceptual view of a Db2 ODBC application \(Db2 Programming for ODBC\)](#)

Related information

[ODBC functions \(Db2 Programming for ODBC\)](#)

Java database connectivity and embedded SQL for Java

Db2 provides two standards-based Java™ programming APIs: Java Database Connectivity (JDBC) and embedded SQL for Java (SQL/OLB or SQLJ). Both can be used to create Java applications and applets that access Db2.

Static SQL cannot be used by JDBC. SQLJ applications use JDBC as a foundation for such tasks as connecting to databases and handling SQL errors, but can contain embedded static SQL statements in the SQLJ source files. An SQLJ file has to be translated with the SQLJ translator before the resulting Java source code can be compiled.

Related concepts

[Java application development for IBM data servers \(Db2 Application Programming for Java\)](#)

[Supported drivers for JDBC and SQLJ \(Db2 Application Programming for Java\)](#)

Use of QMF for Workstation

QMF for Workstation is a tool that helps you build and manage powerful queries without requiring previous experience with SQL.

With the query-related features of Db2 Query Management Facility (QMF) and QMF for Workstation in particular, you can perform the following tasks:

- Build powerful queries without knowing SQL
- Analyze query results online, including OLAP analysis
- Edit query results to update Db2 data
- Format traditional text-based reports and reports with rich formatting
- Display charts and other complex visuals
- Send query results to an application of your choice
- Develop applications using robust API commands

How SQL statements are entered and processed

You can create your SQL statements using QMF for Workstation in several ways:

- Use the Database Explorer window to easily find and run saved queries that everyone at the same database server can share.
- If you know SQL, type the SQL statement directly in the window.
- If you don't know SQL, use the prompted or diagram interface to build the SQL statement.

The Database Explorer presents the objects that are saved on a server in a tree structure. By expanding and collapsing branches, you can easily locate and use saved queries. You can open the selected query and see the SQL statements or run the query.

If you need to build a new query, you can enter the SQL statements directly in the query window, or you can create the SQL statements using diagrams or prompts. As you build a query by using diagrams or prompts, you can open a view to see the SQL that is being created.

How you can work with query results

When you finish building the query, you can click the **Run Query** button to execute the SQL statements. After you run the query, QMF for Workstation returns the query results in an interactive window.

The query results are formatted by the comprehensive formatting options of QMF for Workstation. A robust expression language lets you conditionally format query results by retrieved column values. You can add calculated columns to the query results and group data columns on both axes with or without summaries. You can also use extensive drag-and-drop capabilities to easily restructure the appearance of the query results.

In addition to formatting the query results, you can perform the following actions:

- Create traditional text-based reports or state-of-the-art reports with rich formatting.
- Display query results by using charts and other complex visuals.
- Share reports by storing them on the database server.
- Send query results to various applications such as Microsoft Excel or Lotus® 1-2-3.

Related reference

[Db2 Query Management Facility \(QMF\) information](#)

Db2 database objects overview

In Db2 for z/OS, you use database objects, such as tables, table spaces, indexes, index spaces, keys, views, and databases to organize and access your data.

The brief descriptions here show how the structures fit into an overall view of Db2. The following figure shows how some Db2 structures contain others. To some extent, the notion of "containment" provides a hierarchy of structures.

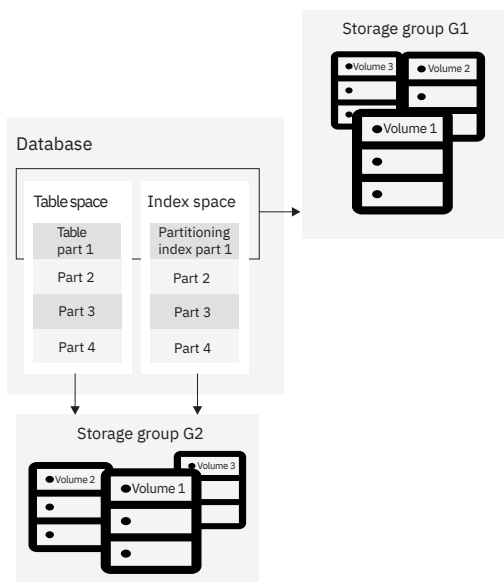

Figure 2. A hierarchy of Db2 structures

The Db2 structures from the most to the least inclusive are:

Databases

A set of Db2 structures that include a collection of tables, their associated indexes, and the table spaces in which they reside.

Storage groups

A set of volumes on disks that hold the data sets in which tables and indexes are stored.

Table spaces

A logical unit of storage in a database. A table space is a page set. The recommended partition-by-growth and partition-by-range table space types always contain data for only a single table. However, the segmented (non-UTS) and simple table space types, which are deprecated, can each contain one or more tables. For more information, see [Table space types and characteristics in Db2 for z/OS \(Db2 Administration Guide\)](#).

Deprecated function: [FL 504 Non-UTS table spaces for base tables](#) are deprecated. CREATE TABLESPACE statements that run at application compatibility level V12R1M504 or higher always create a partition-by-growth or partition-by-range table space, and CREATE TABLE statements that specify a non-UTS table space (including existing multi-table segmented table spaces) return an error. However, you can use a lower application compatibility level to create table spaces of the deprecated types if needed, such as for recovery situations. For instructions, see [Creating non-UTS table spaces \(deprecated\)](#) (Db2 Administration Guide).

Tables

All data in a Db2 database is presented in *tables*, which are collections of rows all having the same columns. A table that holds persistent user data is a *base table*. A table that stores data temporarily is a *temporary table*.

Views

A *view* is an alternative way of representing data that exists in one or more tables. A view can include all or some of the columns from one or more base tables.

Indexes

An *index* is an ordered set of pointers to the data in a Db2 table. The index is stored separately from the table. An index is either a simple index or an extended index. An extended index is one of the following objects:

- An expression-based index
- A spatial index
- An XML index

Related concepts

[Db2 system objects \(Introduction to Db2 for z/OS\)](#)

[Implementing your database design \(Db2 Administration Guide\)](#)

[Storage structures \(Introduction to Db2 for z/OS\)](#)

Db2 schemas and schema qualifiers

The objects in a relational database are organized into sets called schemas. A *schema* is a collection of named objects that provides a logical classification of objects in the database. The first part of a schema name is the qualifier.

A schema provides a logical classification of objects in the database. The objects that a schema can contain include tables, indexes, table spaces, distinct types, functions, stored procedures, and triggers. An object is assigned to a schema when it is created.

The *schema name* of the object determines the schema to which the object belongs. A user object, such as a distinct type, function, procedure, sequence, or trigger should not be created in a *system schema*, which is any one of a set of schemas that are reserved for use by the Db2 subsystem.

When a table, index, table space, distinct type, function, stored procedure, or trigger is created, it is given a qualified two-part name. The first part is the schema name (or the qualifier), which is either implicitly or explicitly specified. The default schema is the authorization ID of the owner of the plan or package. The second part is the name of the object.

In previous versions, CREATE statements had certain restrictions when the value of CURRENT SCHEMA was different from CURRENT SQLID value. Although those restrictions no longer exist, you now must consider how to determine the qualifier and owner when CURRENT SCHEMA and CURRENT SQLID contain different values. The rules for how the owner is determined depend on the type of object being created.

CURRENT SCHEMA and CURRENT SQLID affect only dynamic SQL statements. Static CREATE statements are not affected by either CURRENT SCHEMA or CURRENT SQLID.

The following table summarizes the effect of CURRENT SCHEMA in determining the schema qualifier and owner for these objects:

- Alias

- Auxiliary table
- Created global temporary table
- Table
- View

Table 1. Schema qualifier and owner for objects

Specification of name for new object being created	Schema qualifier of new object	Owner of new object
<i>name</i> (no qualifier)	value of CURRENT SCHEMA	value of CURRENT SQLID
<i>abc.name</i> (single qualifier)	abc	abc
<i>.....abc.name</i> (multiple qualifiers)	abc	abc

The following table summarizes the effect of CURRENT SCHEMA in determining the schema qualifier and owner for these objects:

- User-defined type
- User-defined function
- Procedure
- Sequence
- Trigger

Table 2. Schema qualifier and owner for additional objects

Specification of name for new object being created	Schema qualifier of new object	Owner of new object
<i>name</i> (no qualifier)	value of CURRENT SCHEMA	value of CURRENT SQLID
<i>abc.name</i> (single qualifier)	abc	value of CURRENT SQLID
<i>.....abc.name</i> (multiple qualifiers)	abc	value of CURRENT SQLID

Related reference

[Reserved schema names in Db2 for z/OS](#)

In general, for certain objects, schema names that begin with the prefix SYS are reserved. The schema name for these objects cannot begin with SYS except for certain exceptions.

Db2 tables

Tables are logical structures that Db2 maintains. Db2 supports several different types of tables.

Tables are made up of columns and rows. The rows of a relational table have no fixed order. The order of the columns, however, is always the order in which you specified them when you defined the table.

At the intersection of every column and row is a specific data item, which is called a *value*. A *column* is a set of values of the same type. A *row* is a sequence of values such that the *n*th value is a value of the *n*th column of the table. Every table must have one or more columns, but the number of rows can be zero.

Db2 accesses data by referring to its content instead of to its location or organization in storage.

Db2 supports the following types of tables:

accelerator-only table

A table that stores rows only in the accelerator, not in Db2. The table and column definition of the accelerator-only table is contained in Db2 catalog tables. Any queries that reference the accelerator-only table, must be executed in the accelerator. If a query that references an accelerator-only table

is not eligible for query acceleration, an error is issued. To change the contents of an accelerator-only table, the data change statement must be executed in the accelerator.

archive table

A table that stores rows that are deleted from another table.

archive-enabled table

A table that has an associated archive table. When rows are deleted from an archive-enabled table, Db2 can automatically insert those rows into an archive table.

auxiliary table

A table created with the SQL statement `CREATE AUXILIARY TABLE` and used to hold the data for a column that is defined in a base table.

base table

The most common type of table in Db2. You create a base table with the SQL `CREATE TABLE` statement. The Db2 catalog table, `SYSIBM.SYSTABLES`, stores the description of the base table. The table description and table data are persistent. All programs and users that refer to this type of table refer to the same description of the table and to the same instance of the table.

clone table

A table that is structurally identical to a base table. You create a clone table by using an `ALTER TABLE` statement for the base table that includes an `ADD CLONE` clause. The clone table is created in a different instance of the same table space as the base table, is structurally identical to the base table in every way, and has the same indexes, before triggers, and LOB objects. In the Db2 catalog, the `SYSTABLESPACE` table indicates that the table space has only one table in it, but `SYSTABLESPACE.CLONE` indicates that a clone table exists. Clone tables can be created only in a partition-by range or partition-by-growth table space that is managed by Db2. The base and clone table each have separate underlying VSAM data sets (identified by their data set instance numbers) that contain independent rows of data.

empty table

A table with zero rows.

history table

A table that is used to store historical versions of rows from the associated system-period temporal table.

materialized query table

A table, which you define with the SQL `CREATE TABLE` statement, that contains materialized data that is derived from one or more source tables. Materialized query tables are useful for complex queries that run on large amounts of data. Db2 can precompute all or part of such queries and use the precomputed, or materialized, results to answer the queries more efficiently. Materialized query tables are commonly used in data warehousing and business intelligence applications.

Several Db2 catalog tables, including `SYSIBM.SYSTABLES` and `SYSIBM.SYSVIEWS`, store the description of the materialized query table and information about its dependency on a table, view, or function. The attributes that define a materialized query table tell Db2 whether the table is:

- System-maintained or user-maintained.
- Refreshable: All materialized tables can be updated with the `REFRESH TABLE` statement. Only user-maintained materialized query tables can also be updated with the `LOAD` utility and the `UPDATE`, `INSERT`, and `DELETE` SQL statements.
- Enabled for query optimization: You can enable or disable the use of a materialized query table in automatic query rewrite.

Materialized query tables can be used to improve the performance of dynamic SQL queries. If Db2 determines that a portion of a query could be resolved using a materialized query table, the query might be rewritten by Db2 to use the materialized query table. This decision is based in part on the settings of the `CURRENT REFRESH AGE` and the `CURRENT MAINTAINED TABLE TYPES FOR OPTIMIZATION` special registers.

result table

A table that contains a set of rows that Db2 selects or generates, directly or indirectly, from one or more base tables in response to an SQL statement. Unlike a base table or a temporary table, a result table is not an object that you define using a CREATE statement.

sample table

One of several tables shipped with the Db2 licensed program that contains sample data. Many examples in this information are based on sample tables.

temporal table

A table that records the period of time when a row is valid.

Db2 supports two types of periods, which are the system period (SYSTEM_TIME) and the application period (BUSINESS_TIME). The system period consists of a pair of columns with system-maintained values that indicates the period of time when a row is valid. The application period consists of a pair of columns with application-maintained values that indicates the period of time when a row is valid.

system-period temporal table

A system-period temporal table is a base table that is defined with system-period data versioning. You can modify an existing table to become a system-period temporal table by specifying the ADD PERIOD SYSTEM_TIME clause on the ALTER TABLE statement. After creating a history table that corresponds to the system-period temporal table, you can define system-period data versioning on the table by issuing the ALTER TABLE ADD VERSIONING statement with the USE HISTORY table clause.

application-period temporal table

An application-period temporal table is a base table that includes an application period (BUSINESS_TIME). You can modify an existing table to become an application-period temporal table by specifying the ADD PERIOD BUSINESS_TIME clause on the ALTER TABLE statement.

bitemporal table

A bitemporal table is a table that is both a system-period temporal table and an application-period temporal table. You can use a bitemporal table to keep application period information and system-based historical information. Therefore, you have a lot of flexibility in how you query data, based on periods of time.

temporary table

A table that is defined by the SQL statement CREATE GLOBAL TEMPORARY TABLE or DECLARE GLOBAL TEMPORARY TABLE to hold data temporarily. Temporary tables are especially useful when you need to sort or query intermediate result tables that contain many rows, but you want to store only a small subset of those rows permanently.

created global temporary table

A table that you define with the SQL CREATE GLOBAL TEMPORARY TABLE statement. The Db2 catalog table, SYSIBM.SYSTABLES, stores the description of the created temporary table. The description of the table is persistent and shareable. However, each individual application process that refers to a created temporary table has its own distinct instance of the table. That is, if application process A and application process B both use a created temporary table named TEMPTAB:

- Each application process uses the same table description.
- Neither application process has access to or knowledge of the rows in the other application instance of TEMPTAB.

declared global temporary table

A table that you define with the SQL DECLARE GLOBAL TEMPORARY TABLE statement. The Db2 catalog does not store a description of the declared temporary table. Therefore, the description and the instance of the table are not persistent. Multiple application processes can refer to the same declared temporary table by name, but they do not actually share the same description or instance of the table. For example, assume that application process A defines a declared temporary table named TEMP1 with 15 columns. Application process B defines a declared temporary table named TEMP1 with five columns. Each application process uses its own

description of TEMP1; neither application process has access to or knowledge of rows in the other application instance of TEMP1.

XML table

A special table that holds only XML data. When you create a table with an XML column, Db2 implicitly creates an XML table space and an XML table to store the XML data.

Related concepts

[Types of tables \(Db2 Administration Guide\)](#)

Related reference

[CREATE TABLE statement](#)

The CREATE TABLE statement defines a table. The definition must include its name and the names and attributes of its columns. The definition can include other attributes of the table, such as its primary key and its table space.

[ALTER TABLE statement](#)

The ALTER TABLE statement changes the description of a table at the current server.

Db2 keys

A *key* is a column or an ordered collection of columns that is identified in the description of a table, an index, or a referential constraint. Keys are crucial to the table structure in a relational database.

Keys are important in a relational database because they ensure that each record in a table is uniquely identified, they help establish and enforce referential integrity, and they establish relationships between tables. The same column can be part of more than one key.

A *composite key* is an ordered set of two or more columns of the same table. The ordering of the columns is not constrained by their actual order within the table. The term *value*, when used with respect to a composite key, denotes a composite value. For example, consider this rule: "The value of the foreign key must be equal to the value of the primary key." This rule means that each component of the value of the foreign key must be equal to the corresponding component of the value of the primary key.

Db2 supports several types of keys.

Unique keys

A *unique constraint* is a rule that the values of a key are valid only if they are unique. A key that is constrained to have unique values is a *unique key*. Db2 uses a *unique index* to enforce the constraint during the execution of the LOAD utility and whenever you use an INSERT, UPDATE, or MERGE statement to add or modify data. Every unique key is a key of a unique index. You can define a unique key by using the UNIQUE clause of either the CREATE TABLE or the ALTER TABLE statement. A table can have any number of unique keys.

The columns of a unique key cannot contain null values.

Primary keys

A *primary key* is a special type of unique key and cannot contain null values. For example, the DEPTNO column in the DEPT table is a primary key.

A table can have no more than one primary key. Primary keys are optional and can be defined in CREATE TABLE or ALTER TABLE statements.

The unique index on a primary key is called a *primary index*. When a primary key is defined in a CREATE TABLE statement or ALTER TABLE statement, Db2 automatically creates the primary index.

If a unique index already exists on the columns of the primary key when it is defined in the ALTER TABLE statement, this unique index is designated as the primary index when Db2 is operating in new-function mode and implicitly created the table space.

Parent keys

A *parent key* is either a primary key or a unique key in the parent table of a referential constraint. The values of a parent key determine the valid values of the foreign key in the constraint.

Foreign keys

A *foreign key* is a key that is specified in the definition of a referential constraint in a CREATE or ALTER TABLE statement. A foreign key refers to or is related to a specific parent key.

Unlike other types of keys, a foreign key does not require an index on its underlying column or columns. A table can have zero or more foreign keys. The value of a composite foreign key is null if any component of the value is null.

The following figure shows the relationship between some columns in the DEPT table and the EMP table.

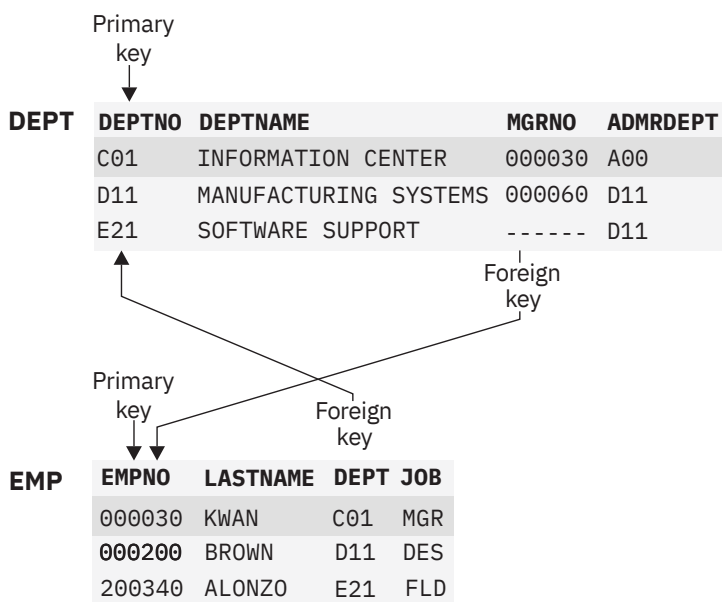

Figure 3. Relationship between DEPT and EMP tables

Figure notes: Each table has a primary key:

- DEPTNO in the DEPT table
- EMPNO in the EMP table

Each table has a foreign key that establishes a relationship between the tables:

- The values of the foreign key on the DEPT column of the EMP table match values in the DEPTNO column of the DEPT table.
- The values of the foreign key on the MGRNO column of the DEPT table match values in the EMPNO column of the EMP table when an employee is a manager.

To see a specific relationship between rows, notice how the shaded rows for department C01 and employee number 000030 share common values.

Related concepts

[Referential constraints \(Introduction to Db2 for z/OS\)](#)

Constraints

A *constraint* is rules that Db2 enforces for column values to prevent duplicate values or set restrictions on data added to a table.

Db2 uses the following types of constraints.

Related concepts

[Ways to maintain data integrity \(Db2 Application programming and SQL\)](#)

Unique constraints

A *unique constraint* is a rule that the values of a key are valid only if they are unique in a table.

Unique constraints are optional and can be defined in the CREATE TABLE or ALTER TABLE statements with the PRIMARY KEY clause or the UNIQUE clause. The columns specified in a unique constraint must be defined as NOT NULL. A unique index enforces the uniqueness of the key during changes to the columns of the unique constraint.

A table can have an arbitrary number of unique constraints, with at most one unique constraint defined as a primary key. A table cannot have more than one unique constraint on the same set of columns.

A unique constraint that is referenced by the foreign key of a referential constraint is called the *parent key*.

Referential constraints

Db2 ensures referential integrity between your tables when you define referential constraints.

Referential integrity is the state in which all values of all foreign keys are valid. Referential integrity is based on *entity integrity*. Entity integrity requires that each entity have a unique key. For example, if every row in a table represents relationships for a unique entity, the table should have one column or a set of columns that provides a unique identifier for the rows of the table. This column (or set of columns) is called the parent key of the table. To ensure that the parent key does not contain duplicate values, a unique index must be defined on the column or columns that constitute the parent key. Defining the parent key is called entity integrity.

A *referential constraint* is the rule that the nonnull values of a foreign key are valid only if they also appear as values of a parent key. The table that contains the parent key is called the *parent table* of the referential constraint, and the table that contains the foreign key is a *dependent* of that table.

The relationship between some rows of the DEPT and EMP tables, shown in the following figure, illustrates referential integrity concepts and terminology. For example, referential integrity ensures that every foreign key value in the DEPT column of the EMP table matches a primary key value in the DEPTNO column of the DEPT table.

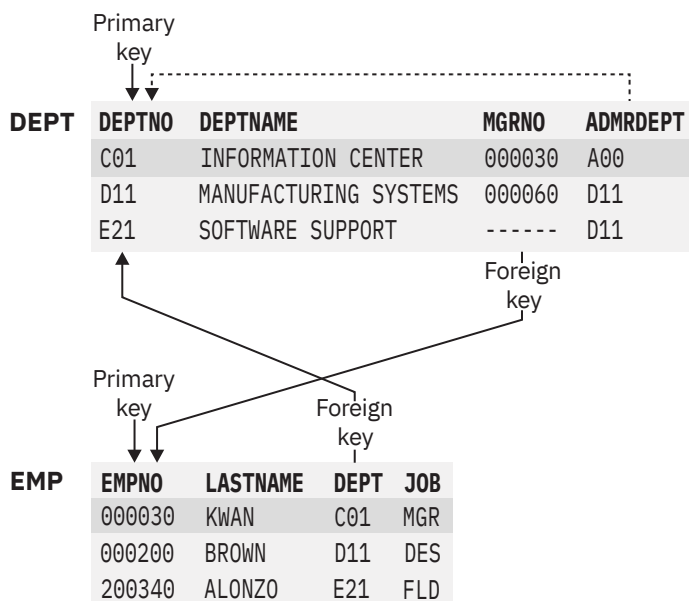

Figure 4. Referential integrity of DEPT and EMP tables

Two parent and dependent relationships exist between the DEPT and EMP tables.

- The foreign key on the DEPT column establishes a parent and dependent relationship. The DEPT column in the EMP table depends on the DEPTNO in the DEPT table. Through this foreign key relationship, the DEPT table is the parent of the EMP table. You can assign an employee to no department (by specifying a null value), but you cannot assign an employee to a department that does not exist.
- The foreign key on the MGRNO column also establishes a parent and dependent relationship. Because MGRNO depends on EMPNO, EMP is the parent table of the relationship, and DEPT is the dependent table.

You can define a primary key on one or more columns. A primary key that includes two or more columns is called a *composite key*. A foreign key can also include one or more columns. When a foreign key contains multiple columns, the corresponding primary key must be a composite key. The number of foreign key columns must be the same as the number of columns in the parent key, and the data types of the corresponding columns must be compatible. (The sample project activity table, DSN8C10.PROJACT, is an example of a table with a primary key on multiple columns, PROJNO, ACTNO, and ACSTDATE.)

A table can be a dependent of itself; this is called a *self-referencing table*. For example, the DEPT table is self-referencing because the value of the administrative department (ADMRDEPT) must be a department ID (DEPTNO). To enforce the self-referencing constraint, Db2 requires that a foreign key be defined.

Similar terminology applies to the rows of a parent-and-child relationship. A row in a dependent table, called a *dependent row*, refers to a row in a parent table, called a *parent row*. But a row of a parent table is not always a parent row—perhaps nothing refers to it. Likewise, a row of a dependent table is not always a dependent row—the foreign key can allow null values, which refer to no other rows.

Referential constraints are optional. You define referential constraints by using CREATE TABLE and ALTER TABLE statements.

Db2 enforces referential constraints when the following actions occur:

- An INSERT statement is applied to a dependent table.
- An UPDATE statement is applied to a foreign key of a dependent table or to the parent key of a parent table.
- A MERGE statement that includes an insert operation is applied to a dependent table.
- A MERGE statement that includes an update operation is applied to a foreign key of a dependent table or to the parent key of a parent table.
- A DELETE statement is applied to a parent table. All affected referential constraints and all delete rules of all affected relationships must be satisfied in order for the delete operation to succeed.
- The LOAD utility with the ENFORCE CONSTRAINTS option is run on a dependent table.
- The CHECK DATA utility is run.

Another type of referential constraint is an *informational referential constraint*. This type of constraint is not enforced by Db2 during normal operations. An application process should verify the data in the referential integrity relationship. An informational referential constraint allows queries to take advantage of materialized query tables.

The order in which referential constraints are enforced is undefined. To ensure that the order does not affect the result of the operation, there are restrictions on the definition of delete rules and on the use of certain statements. The restrictions are specified in the descriptions of the SQL statements CREATE TABLE, ALTER TABLE, INSERT, UPDATE, MERGE, and DELETE.

The rules of referential integrity involve the following concepts and terminology:

parent key

A primary key or a unique key of a referential constraint.

parent table

A table that is a parent in at least one referential constraint. A table can be defined as a parent in an arbitrary number of referential constraints.

dependent table

A table that is a dependent in at least one referential constraint. A table can be defined as a dependent in an arbitrary number of referential constraints. A dependent table can also be a parent table.

descendent table

A table that is a dependent of another table or a table that is a dependent of a descendent table.

referential cycle

A set of referential constraints in which each associated table is a descendent of itself.

parent row

A row that has at least one dependent row.

dependent row

A row that has at least one parent row.

descendent row

A row that is dependent on another row or a row that is a dependent of a descendent row.

self-referencing row

A row that is a parent of itself.

self-referencing table

A table that is both parent and dependent in the same referential constraint. The constraint is called a *self-referencing constraint*.

A temporal referential constraint can be defined for a table that contains a BUSINESS_TIME period. The PERIOD BUSINESS_TIME clause is used in both the FOREIGN KEY clause and the REFERENCES clause to indicate that there must not be a row in the child table for which the period of time represented by the BUSINESS_TIME period value for that row is not contained in the BUSINESS_TIME period of one or more corresponding rows in the parent table. Unlike normal referential constraints, it is not necessary that there be exactly one corresponding row in the parent table where the BUSINESS_TIME period contains the BUSINESS_TIME period of the child row. As long as the BUSINESS_TIME period of a row in the child table is contained in the union of the BUSINESS_TIME periods of two or more contiguous matching rows in the parent table, the temporal referential constraint is satisfied.

Additionally, the following indexes must be defined:

- A unique index on the parent table with the BUSINESS_TIME WITHOUT OVERLAPS clause.
- A non-unique index on the child table with the BUSINESS_TIME WITH OVERLAPS clause. Alternatively, the index on the child table, can be defined without the BUSINESS_TIME WITH OVERLAPS clause if the end of the index key includes the end column followed by the begin column of the BUSINESS_TIME period (both in ascending order).

The following rules provide referential integrity:

insert rule

A nonnull insert value of the foreign key must match some value of the parent key of the parent table. The value of a composite foreign key is null if any component of the value is null.

update rule

A nonnull update value of the foreign key must match some value of the parent key of the parent table. The value of a composite foreign key is treated as null if any component of the value is null.

delete rule

Controls what happens when a row of the parent table is deleted. The choices of action, made when the referential constraint is defined, are RESTRICT, NO ACTION, CASCADE, or SET NULL. SET NULL can be specified only if some column of the foreign key allows null values.

More precisely, the delete rule applies when a row of the parent table is the object of a delete or propagated delete operation and that row has dependents in the dependent table of the referential constraint. A *propagated delete* refers to the situation where dependent rows are deleted when parent rows are deleted. Let *P* denote the parent table, let *D* denote the dependent table, and let *p* denote a parent row that is the object of a delete or propagated delete operation. If the delete rule is:

- RESTRICT or NO ACTION, an error occurs and no rows are deleted.

- CASCADE, the delete operation is propagated to the dependent rows of *p* in *D*.
- SET NULL, each nullable column of the foreign key of each dependent row of *p* in *D* is set to null.

Each referential constraint in which a table is a parent has its own delete rule, and all applicable delete rules are used to determine the result of a delete operation. Thus, a row cannot be deleted if it has dependents in a referential constraint with a delete rule of RESTRICT or NO ACTION or the deletion cascades to any of its descendents that are dependents in a referential constraint with the delete rule of RESTRICT or NO ACTION.

The deletion of a row from parent table *P* involves other tables and can affect rows of these tables:

- If *D* is a dependent of *P* and the delete rule is RESTRICT or NO ACTION, *D* is involved in the operation but is not affected by the operation and the deletion from the parent table *P* does not take place.
- If *D* is a dependent of *P* and the delete rule is SET NULL, *D* is involved in the operation and rows of *D* might be updated during the operation.
- If *D* is a dependent of *P* and the delete rule is CASCADE, *D* is involved in the operation and rows of *D* might be deleted during the operation. If rows of *D* are deleted, the delete operation on *P* is said to be propagated to *D*. If *D* is also a parent table, the actions described in this list apply, in turn, to the dependents of *D*.

Any table that can be involved in a delete operation on *P* is said to be *delete-connected* to *P*. Thus, a table is delete-connected to table *P* if it is a dependent of *P* or a dependent of a table to which delete operations from *P* cascade.

Related concepts

Referential constraints ([Db2 Application programming and SQL](#))

Related reference

Department table (DSN8C10.DEPT) ([Introduction to Db2 for z/OS](#))

Employee table (DSN8C10.EMP) ([Introduction to Db2 for z/OS](#))

Project activity table (DSN8C10.PROJACT) ([Introduction to Db2 for z/OS](#))

Check constraints

A *check constraint* is a rule that specifies the values that are allowed in one or more columns of every row of a base table.

Like referential constraints, check constraints are optional and you define them by using the CREATE TABLE and ALTER TABLE statements. The definition of a check constraint restricts the values that a specific column of a base table can contain.

A table can have any number of check constraints. Db2 enforces a check constraint by applying the restriction to each row that is inserted, loaded, or updated. One restriction is that a column name in a check constraint on a table must identify a column of that table.

For example, you can create a check constraint to ensure that all employees earn a salary of \$30,000 or more:

```
CHECK (SALARY >= 30000)
```

Related concepts

Check constraints ([Db2 Application programming and SQL](#))

Db2 table columns

A column definition has two basic components, the column name and the data type.

A *column* contains values that have the same data type. If you are familiar with the concepts of records and fields, you can think of a *value* as a field in a record. A value is the smallest unit of data that you can manipulate with SQL. For example, in the EMP table, the EMPNO column identifies all employees by a unique employee number. The HIREDATE column contains the hire dates for all employees. You cannot overlap columns.

Online schema enhancements provide flexibility that lets you change a column definition. Carefully consider the decisions that you make about column definitions. After you implement the design of your tables, you can change a column definition with minimal disruption of applications.

Throughout the implementation phase of database design, refer to the complete descriptions of SQL statement syntax and usage for each SQL statement that you work with.

Column names

Following column naming guidelines that are developed for your organization ensures that you make good choices that are consistent.

Generally, the database administrator (DBA) is involved in determining the names of attributes (or columns) during the physical database design phase. To make the right choices for column names, DBAs follow the guidelines that the data administrators developed.

Sometimes columns need to be added to the database after the design is complete. In this case, Db2 rules for unique column names must be followed. Column names must be unique within a table, but you can use the same column name in different tables. Try to choose a meaningful name to describe the data in a column to make your naming scheme intuitive.

For more information, see [“Column names” on page 219](#) and [“Naming conventions in SQL” on page 79](#).

Related concepts

[Data types](#)

Db2 supports both IBM-supplied data types (built-in data types) and user-defined data types (distinct types).

Related tasks

[Altering the data type of a column \(Db2 Administration Guide\)](#)

Related reference

[Employee table \(DSN8C10.EMP\) \(Introduction to Db2 for z/OS\)](#)

Data types of columns

Every column in every Db2 table has a data type. The data type influences the range of values that the column can have and the set of operators and functions that apply to it.

You specify the data type of each column at the time that you create the table. You can also change the data type of a table column. The new data type definition is applied to all data in the associated table when the table is reorganized.

Some data types have parameters that further define the operators and functions that apply to the column. Db2 supports both IBM-supplied data types and user-defined data types. The data types that IBM supplies are sometimes called *built-in data types*.

In Db2 for z/OS, user-defined data types are called *distinct types*.

How Db2 compares values of different data types

Db2 compares values of different types and lengths. A comparison occurs when both values are numeric, both values are character strings, or both values are graphic strings. Comparisons can also occur between character and graphic data or between character and datetime data if the character data is a valid character representation of a datetime value. Different types of string or numeric comparisons might have an impact on performance.

Related concepts

[Entity attributes in database design \(Introduction to Db2 for z/OS\)](#)

[Data types of columns \(Db2 Application programming and SQL\)](#)

[Assignment and comparison](#)

The basic operations of SQL are assignment and comparison.

Casting between data types

There are many occasions when a value with a given data type needs to be *cast* (changed) to a different data type or to the same data type with a different length, precision, or scale.

Rules for result data types

Rules that are applied to the operands of an operation determine the data type of the result. Certain rules apply in certain situations and apply depending on the data type of operands.

Distinct types (Introduction to Db2 for z/OS)

String data types

Db2 supports several types of string data: character strings, graphic strings, and binary strings.

Character strings contain text and can be either a fixed-length or a varying-length. *Graphic strings* contain graphic data, which can also be either a fixed-length or a varying-length. *Binary strings* contain strings of binary bytes and can be either a fixed-length or a varying-length. All of these types of string data can be represented as large objects.

The following table describes the different string data types and indicates the range for the length of each string data type.

Table 3. String data types

Data type	Denotes a column of...
CHARACTER(<i>n</i>)	Fixed-length character strings with a length of <i>n</i> bytes. <i>n</i> must be greater than 0 and not greater than 255. The default length is 1.
VARCHAR(<i>n</i>)	Varying-length character strings with a maximum length of <i>n</i> bytes. <i>n</i> must be greater than 0 and less than a number that depends on the page size of the table space. The maximum length is 32704.
CLOB(<i>n</i>)	Varying-length character strings with a maximum of <i>n</i> characters. <i>n</i> cannot exceed 2,147,483,647. The default length is 1M.
GRAPHIC(<i>n</i>)	Fixed-length graphic strings that contain <i>n</i> double-byte characters. <i>n</i> must be greater than 0 and less than 128. The default length is 1.
VARGRAPHIC(<i>n</i>)	Varying-length graphic strings. The maximum length, <i>n</i> , must be greater than 0 and less than a number that depends on the page size of the table space. The maximum length is 16352.
DBCLOB(<i>n</i>)	Varying-length strings of double-byte characters with a maximum of <i>n</i> double-byte characters. <i>n</i> cannot exceed 1,073,741,824. The default length is 1M.
BINARY(<i>n</i>)	Fixed-length or varying-length binary strings with a length of <i>n</i> bytes. <i>n</i> must be greater than 0 and not greater than 255. The default length is 1.
VARBINARY(<i>n</i>)	Varying-length binary strings with a length of <i>n</i> bytes. The length of <i>n</i> must be greater than 0 and less than a number that depends on the page size of the table space. The maximum length is 32704.
BLOB(<i>n</i>)	Varying-length binary strings with a length of <i>n</i> bytes. <i>n</i> cannot exceed 2,147,483,647. The default length is 1M.

In most cases, the content of the data that a column is to store dictates the data type that you choose.

Example

For example, assume that the DEPT table has a column, DEPTNAME. The data type of the DEPTNAME column is VARCHAR(36). Because department names normally vary considerably in length, the choice of a varying-length data type seems appropriate. If you choose a data type of CHAR(36), for example, the

result is a lot of wasted, unused space. In this case, Db2 assigns all department names, regardless of length, the same amount of space (36 bytes). A data type of CHAR(6) for the employee number (EMPNO) is a reasonable choice because all values are fixed-length values (6 bytes).

Fixed-length and variable-length character strings

Using VARCHAR saves disk space, but it incurs a 2-byte overhead cost for each value. Using VARCHAR also requires additional processing for varying-length rows. Therefore, using CHAR is preferable to VARCHAR, unless the space that you save by using VARCHAR is significant. The savings are not significant if the maximum column length is small or if the lengths of the values do not have a significant variation.

Recommendation: Generally, do not define a column as VARCHAR(*n*) or CLOB(*n*) unless *n* is at least 18 characters.

String subtypes

If an application that accesses your table uses a different encoding scheme than your DBMS uses, the following string subtypes can be important:

BIT

Does not represent characters.

SBCS

Represents single-byte characters.

MIXED

Represents single-byte characters and multibyte characters.

String subtypes apply only to CHAR, VARCHAR, and CLOB data types. However, the BIT string subtype is not allowed for the CLOB data type.

Graphic and mixed data

When columns contain *double-byte character set* (DBCS) characters, you can define them as either graphic data or mixed data.

Graphic data can be either GRAPHIC, VARGRAPHIC, or DBCLOB. Using VARGRAPHIC saves disk space, but it incurs a 2-byte overhead cost for each value. Using VARGRAPHIC also requires additional processing for varying-length rows. Therefore, using GRAPHIC data is preferable to using VARGRAPHIC unless the space that you save by using VARGRAPHIC is significant. The savings are not significant if the maximum column length is small or if the lengths of the values do not vary significantly.

Recommendation: Generally, do not define a column as VARGRAPHIC(*n*) unless *n* is at least 18 double-byte characters (which is a length of 36 bytes).

Mixed-data character string columns can contain both *single-byte character set* (SBCS) and DBCS characters. You can specify the mixed-data character string columns as CHAR, VARCHAR, or CLOB with MIXED DATA.

Recommendation: If all of the characters are DBCS characters, use the graphic data types. (Kanji is an example of a language that requires DBCS characters.) For SBCS characters, use mixed data to save 1 byte for every single-byte character in the column.

Encoding schemes for string data

For string data, all characters are represented by a common encoding representation (Unicode, ASCII, or EBCDIC). Encoding schemes apply to string data types and to distinct types that are based on string types.

Multinational companies that engage in international trade often store data from more than one country in the same table. Some countries use different coded character set identifiers. Db2 for z/OS supports the Unicode encoding scheme, which represents many different geographies and languages. If you need

to perform character conversion on Unicode data, the conversion is more likely to preserve all of your information.

In some cases, you might need to convert characters to a different encoding representation. The process of conversion is known as *character conversion*. Most users do not need a knowledge of character conversion. When character conversion does occur, it does so automatically and a successful conversion is invisible to the application and users.

Related concepts

[Distinct types \(Introduction to Db2 for z/OS\)](#)

[Character strings](#)

A *character string* is a sequence of bytes. The length of the string is the number of bytes in the sequence. If the length is zero, the value is called the *empty string*. The empty string should not be confused with the null value.

[Graphic strings](#)

A *graphic string* is a sequence of double-byte characters.

[Binary strings](#)

A *binary string* is a sequence of bytes.

[Introduction to character conversion \(Db2 Internationalization Guide\)](#)

Related reference

[Department table \(DSN8C10.DEPT\) \(Introduction to Db2 for z/OS\)](#)

Numeric data types

Db2 supports several types of numeric data types, each of which has its own characteristics.

For numeric data, use numeric columns rather than string columns. Numeric columns require less space than string columns, and Db2 verifies that the data has the assigned type.

For example, assume that Db2 calculates a range between two numbers. If the values have a string data type, Db2 assumes that the values can include all combinations of alphanumeric characters. In contrast, if the values have a numeric data type, Db2 can calculate a range between the two values more efficiently.

The following table describes the numeric data types.

Table 4. Numeric data types

Data type	Denotes a column of...
SMALLINT	Small integers. A <i>small integer</i> is binary integer with a precision of 15 bits. The range is -32768 to +32767.
INTEGER or INT	Large integers. A <i>large integer</i> is binary integer with a precision of 31 bits. The range is -2147483648 to +2147483647.
BIGINT	Big integers. A <i>big integer</i> is a binary integer with a precision of 63 bits. The range of big integers is -9223372036854775808 to +9223372036854775807.
DECIMAL or NUMERIC	<p>A <i>decimal</i> number is a packed decimal number with an implicit decimal point. The position of the decimal point is determined by the precision and the scale of the number. The scale, which is the number of digits in the fractional part of the number, cannot be negative or greater than the precision. The maximum precision is 31 digits.</p> <p>All values of a decimal column have the same precision and scale. The range of a decimal variable or the numbers in a decimal column is $-n$ to $+n$, where n is the largest positive number that can be represented with the applicable precision and scale. The maximum range is $1 - 10^{31}$ to $10^{31} - 1$.</p>

Table 4. Numeric data types (continued)

Data type	Denotes a column of...
DECFLOAT	A <i>decimal floating-point</i> value is an IEEE 754r number with a decimal point. The position of the decimal point is stored in each decimal floating-point value. The maximum precision is 34 digits. The range of a decimal floating-point number is either 16 or 34 digits of precision; the exponent range is respectively 10-383 to 10+384 or 10-6143 to 10+6144.
REAL	A <i>single-precision floating-point</i> number is a short floating-point number of 32 bits. The range of single-precision floating-point numbers is approximately -7.2E+75 to 7.2E+75. In this range, the largest negative value is about -5.4E-79, and the smallest positive value is about 5.4E-079.
DOUBLE	A <i>double-precision floating-point</i> number is a long floating-point number of 64-bits. The range of double-precision floating-point numbers is approximately -7.2E+75 to 7.2E+75. In this range, the largest negative value is about -5.4E-79, and the smallest positive value is about 5.4E-79.

Note: IBM zSystems and z/Architecture® use the System/390® format and support IEEE floating-point format.

For integer values, use SMALLINT, INTEGER, or BIGINT (depending on the range of the values). Do not use DECIMAL for integer values.

You can define an exact numeric column as an identity column. An *identity column* has an attribute that enables Db2 to automatically generate a unique numeric value for each row that is inserted into the table. Identity columns are ideally suited to the task of generating unique primary-key values. Applications that use identity columns might be able to avoid concurrency and performance problems that sometimes occur when applications implement their own unique counters.

Date, time, and timestamp data types

Although storing dates and times as numeric values is possible, using datetime data types is recommended. The datetime data types are DATE, TIME, and TIMESTAMP.

The following table describes the data types for dates, times, and timestamps.

Table 5. Date, time, and timestamp data types

Data type	Denotes a column of...
DATE	A <i>date</i> is a three-part value representing a year, month, and day in the range of 0001-01-01 to 9999-12-31.
TIME	A <i>time</i> is a three-part value representing a time of day in hours, minutes, and seconds, in the range of 00.00.00 to 24.00.00.
TIMESTAMP	A <i>timestamp</i> is a seven-part value representing a date and time by year, month, day, hour, minute, second, and microsecond, in the range of 0001-01-01-00.00.00.000000000 to 9999-12-31-24.00.00.000000000 with nanosecond precision. Timestamps can also hold timezone information.

Db2 stores values of datetime data types in a special internal format. When you load or retrieve data, Db2 can convert it to or from any of the formats in the following table.

Table 6. Date and time format options

Format name	Abbreviation	Typical date	Typical time
International Standards Organization	ISO	2003-12-25	13.30.05

Table 6. Date and time format options (continued)

Format name	Abbreviation	Typical date	Typical time
IBM USA standard	USA	12/25/2003	1:30 PM
IBM European standard	EUR	25.12.2003	13.30.05
Japanese Industrial Standard Christian Era	JIS	2003-12-25	13:30:05

GUIP

Example 1

The following query displays the dates on which all employees were hired, in IBM USA standard form, regardless of the local default:

```
SELECT EMPNO, CHAR(HIREDATE, USA) FROM EMP;
```

Example 2

When you use datetime data types, you can take advantage of Db2 built-in functions that operate specifically on datetime values, and you can specify calculations for datetime values. Assume that a manufacturing company has an objective to ship all customer orders within five days. You define the SHIPDATE and ORDERDATE columns as DATE data types. The company can use datetime data types and the DAYS built-in function to compare the shipment date to the order date. Here is how the company might code the function to generate a list of orders that have exceeded the five-day shipment objective:

```
DAYS(SHIPDATE) – DAYS(ORDERDATE) > 5
```

As a result, programmers do not need to develop, test, and maintain application code to perform complex datetime arithmetic that needs to allow for the number of days in each month.

GUIP

You can use the following sample user-defined functions (which come with Db2) to modify the way dates and times are displayed.

- ALTDATE returns the current date in a user-specified format or converts a user-specified date from one format to another.
- ALTTIME returns the current time in a user-specified format or converts a user-specified time from one format to another.

At installation time, you can also supply an exit routine to make conversions to and from any local standard.

When loading date or time values from an outside source, Db2 accepts any of the date and time format options that are listed in this information. Db2 converts valid input values to the internal format. For retrieval, a default format is specified at Db2 installation time. You can subsequently override that default by using a precompiler option for all statements in a program or by using the scalar function CHAR for a particular SQL statement and by specifying the format that you want.

Related concepts

Datetime constants

A *datetime constant* is a character string constant of a particular format.

XML data type

The XML data type is used to define columns of a table that store XML values. This pureXML® data type provides the ability to store well-formed XML documents in a database.

All XML data is stored in the database in an internal representation. Character data in this internal representation is in the UTF-8 encoding scheme.

XML values that are stored in an XML column have an internal representation that is not a string and not directly comparable to string values. An XML value can be transformed into a serialized string value that represents the XML document by using the XMLSERIALIZE function or by retrieving the value into an application variable of an XML, string, or binary type. Similarly, a string value that represents an XML document can be transformed to an XML value by using the XMLPARSE function or by storing a value from a string, binary, or XML application data type in an XML column.

The size of an XML value in a Db2 table has no architectural limit. However, serialized XML data that is stored in or retrieved from an XML column is limited to 2 GB.

Validation of an XML document against an XML schema, typically performed during INSERT or UPDATE into an XML column, is supported by the XML schema repository (XSR). If an XML column has an XML type modifier, documents that are inserted into the column or updated in the column are automatically validated against an XML schema.

Large object data types

You can use large object data types to store audio, video, images, and other files that are larger than 32 KB.

The VARCHAR, VARGRAPHIC, and VARBINARY data types have a storage limit of 32 KB. However, applications often need to store large text documents or additional data types such as audio, video, drawings, images, and a combination of text and graphics. For data objects that are larger than 32 KB, you can use the corresponding large object (LOB) data types to store these objects.

Db2 provides three data types to store these data objects as strings of up to 2 GB in size:

Character large objects (CLOBs)

Use the CLOB data type to store SBCS or mixed data, such as documents that contain single character set. Use this data type if your data is larger (or might grow larger) than the VARCHAR data type permits.

Double-byte character large objects (DBCLOBs)

Use the DBCLOB data type to store large amounts of DBCS data, such as documents that use a DBCS character set.

Binary large objects (BLOBs)

Use the BLOB data type to store large amounts of noncharacter data, such as pictures, voice, and mixed media.

If your data does not fit entirely within a data page, you can define one or more columns as LOB columns. An advantage to using LOBs is that you can create user-defined functions that are allowed only on LOB data types.

Related concepts

[Large objects \(LOBs\)](#)

The term *large object (LOB)* refers to any of the following data types: CLOB, DBCLOB, or BLOB.

Related tasks

[Creating large objects \(Introduction to Db2 for z/OS\)](#)

ROWID data type

You use the ROWID data type to uniquely identify rows in a Db2 subsystem.

Db2 can generate a value for the column when a row is added, depending on the option that you choose (GENERATED ALWAYS or GENERATED BY DEFAULT) when you define the column. You can use a ROWID column in a table for several reasons.

- You can define a ROWID column to include LOB data in a table.
- You can use direct-row access so that Db2 accesses a row directly through the ROWID column. If an application selects a row from a table that contains a ROWID column, the row ID value implicitly contains the location of the row. If you use that row ID value in the search condition of subsequent SELECT statements, Db2 might be able to navigate directly to the row.

Requirement: To use direct row access, you must use a retrieved ROWID value before you commit. When your application commits, it releases its claim on the table space. After the commit, if a REORG is run on your table space, the physical location of the rows might change.

- You can define a ROWID column with the IMPLICITLY HIDDEN attribute. Such columns are returned only for SQL statements that explicitly name the column. SQL statements that only imply selection of the column, such as statements that specify `SELECT *`, do not return the column.

Related concepts

Row ID values

A *row ID* is a value that uniquely identifies a row in a table. A column or a host variable can have a row ID data type.

[Direct row access \(PRIMARY_ACCESTYPE='D'\) \(Db2 Performance\)](#)

Related tasks

[Specifying direct row access by using row IDs \(Db2 Application programming and SQL\)](#)

Related reference

ROWID scalar function

The ROWID function returns a row ID representation of its argument.

Distinct types

A *distinct type* is a user-defined data type that is based on existing built-in Db2 data types.

A distinct type is internally the same as a built-in data type, but Db2 treats them as a separate and incompatible type for semantic purposes. Defining your own distinct type ensures that only functions that are explicitly defined on a distinct type can be applied to its instances.

Examples

GUI

Example 1

You might define a US_DOLLAR distinct type that is based on the Db2 DECIMAL data type to identify decimal values that represent United States dollars. The US_DOLLAR distinct type does not automatically acquire the functions and operators of its source type, DECIMAL.

Although you can have different distinct types that are based on the same built-in data types, distinct types have the property of *strong typing*. With this property, you cannot directly compare instances of a distinct type with anything other than another instance of that same type. Strong typing prevents semantically incorrect operations (such as explicit addition of two different currencies) without first undergoing a conversion process. You define which types of operations can occur for instances of a distinct type.

If your company wants to track sales in many countries, you must convert the currency for each country in which you have sales.

Example 2

You can define a distinct type for each country. For example, to create US_DOLLAR types and CANADIAN_DOLLAR types, you can use the following CREATE DISTINCT TYPE statements:

```
CREATE DISTINCT TYPE US_DOLLAR AS DECIMAL (9,2);
CREATE DISTINCT TYPE CANADIAN_DOLLAR AS DECIMAL (9,2);
```

Example 3

After you define distinct types, you can use them in your CREATE TABLE statements:

```
CREATE TABLE US_SALES
  (PRODUCT_ITEM_NO INTEGER,
   MONTH            INTEGER,
   YEAR             INTEGER,
   TOTAL_AMOUNT    US_DOLLAR);
CREATE TABLE CANADIAN_SALES
  (PRODUCT_ITEM_NO INTEGER,
   MONTH            INTEGER,
```

```
YEAR      INTEGER,  
TOTAL_AMOUNT  CANADIAN_DOLLAR);
```

GUIP

User-defined functions support the manipulation of distinct types.

Related concepts

[String data types \(Introduction to Db2 for z/OS\)](#)

[Distinct types](#)

A *distinct type* is a user-defined data type that shares its internal representation with a built-in data type (its *source type*), but is considered to be a separate and incompatible data type for most operations.

[User-defined type assignments](#)

User-defined type assignments include distinct type assignments and array assignments.

[User-defined type comparisons](#)

User-defined type comparisons include distinct type comparisons and array comparisons.

Null values in table columns

Some columns cannot have a meaningful value in every row. Db2 uses a special value indicator, the *null value*, to stand for an unknown or missing value. A null value is a special value that Db2 interprets to mean that no data is present.

If you do not specify otherwise, Db2 allows any column to contain null values. Users can create rows in the table without providing a value for the column.

Using the NOT NULL clause enables you to disallow null values in the column. Primary keys must be defined as NOT NULL.

Example

GUIP

For example, The table definition for the DEPT table specifies when you can use a null value. Notice that you can use nulls for the MGRNO column only:

```
CREATE TABLE DEPT  
  (DEPTNO  CHAR(3)          NOT NULL,  
   DEPTNAME VARCHAR(36)     NOT NULL,  
   MGRNO   CHAR(6)          ,  
   ADMRDEPT CHAR(3)        NOT NULL,  
   PRIMARY KEY (DEPTNO)   )  
IN MYDB.MYTS;
```

GUIP

Before you decide whether to allow nulls for unknown values in a particular column, you must be aware of how nulls affect results of a query:

Nulls in application programs

Nulls do not satisfy any condition in an SQL statement other than the special IS NULL predicate. Db2 sorts null values differently than non-null values. Null values do not behave like other values. For example, if you ask Db2 whether a null value is larger than a given known value, the answer is UNKNOWN. If you then ask Db2 whether a null value is smaller than the same known value, the answer is still UNKNOWN.

If getting a value of UNKNOWN is unacceptable for a particular column, you could define a default value instead. Programmers are familiar with the way default values behave.

Nulls in join operations

Nulls need special handling in join operations. If you perform a join operation on a column that can contain null values, consider using an outer join.

Related concepts

[When to use null or default values \(Introduction to Db2 for z/OS\)](#)

[Data types](#)

Db2 supports both IBM-supplied data types (built-in data types) and user-defined data types (distinct types).

[Ways to join data from more than one table \(Introduction to Db2 for z/OS\)](#)

[Default values for table columns \(Introduction to Db2 for z/OS\)](#)

[Entity attributes in database design \(Introduction to Db2 for z/OS\)](#)

Related reference

[CREATE TABLE statement](#)

The CREATE TABLE statement defines a table. The definition must include its name and the names and attributes of its columns. The definition can include other attributes of the table, such as its primary key and its table space.

[ALTER TABLE statement](#)

The ALTER TABLE statement changes the description of a table at the current server.

Default values for table columns

Db2 defines some default values, and you define others (by using the DEFAULT clause in the CREATE TABLE or ALTER TABLE statement).

If a column is defined as NOT NULL WITH DEFAULT or if you do not specify NOT NULL, Db2 stores a default value for a column whenever an insert or load does not provide a value for that column. If a column is defined as NOT NULL, Db2 does not supply a default value.

Default values defined by Db2

Db2 generates a default value for ROWID columns. Db2 also determines default values for columns that users define with NOT NULL WITH DEFAULT, but for which no specific value is specified, as shown in the following table.

Table 7. Db2-defined default values for data types

For columns of...	Data types	Default
Numbers	SMALLINT, INTEGER, BIGINT, DECIMAL, NUMERIC, REAL, DOUBLE, DECFLOAT, or FLOAT	0
Fixed-length strings	CHAR or GRAPHIC	Blanks
	BINARY	Hexadecimal zeros
Varying-length strings	VARCHAR, CLOB, VARGRAPHIC, DBCLOB, VARBINARY, or BLOB	Empty string
Dates	DATE	CURRENT DATE
Times	TIME	CURRENT TIME
Timestamps	TIMESTAMP	CURRENT TIMESTAMP
ROWIDs	ROWID	Db2-generated

User-defined default values

You can specify a particular default value, such as:

```
DEFAULT 'N/A'
```

When you choose a default value, you must be able to assign it to the data type of the column. For example, all string constants are VARCHAR. You can use a VARCHAR string constant as the default for a CHAR column even though the type isn't an exact match. However, you could not specify a default value of 'NA' for a column with a numeric data type.

In the next example, the columns are defined as CHAR (fixed length). The special registers (USER and CURRENT SQLID) that are referenced contain varying length values.

For example, if you want a record of each user who inserts any row of a table, define the table with two additional columns:

```
PRIMARY_ID    CHAR(8)    WITH DEFAULT USER,  
SQL_ID       CHAR(8)    WITH DEFAULT CURRENT SQLID,
```

You can then create a view that omits those columns and allows users to update the view instead of the base table. Db2 then adds, by default, the primary authorization ID and the SQLID of the process.

When you add columns to an existing table, you must define them as nullable or as not null with default. Assume that you add a column to an existing table and specify not null with default. If Db2 reads from the table before you add data to the column, the column values that you retrieve are the default values. With few exceptions, the default values for retrieval are the same as the default values for insert.

Default values for ROWID

Db2 always generates the default values for ROWID columns.

Related concepts

[When to use null or default values \(Introduction to Db2 for z/OS\)](#)

[Authorization and security mechanisms for data access \(Introduction to Db2 for z/OS\)](#)

[Null values in table columns \(Introduction to Db2 for z/OS\)](#)

Related reference

[CREATE TABLE statement](#)

The CREATE TABLE statement defines a table. The definition must include its name and the names and attributes of its columns. The definition can include other attributes of the table, such as its primary key and its table space.

[ALTER TABLE statement](#)

The ALTER TABLE statement changes the description of a table at the current server.

Related information

[Implementing Db2 tables \(Db2 Administration Guide\)](#)

When to use null or default values

Using a null value is easier and better than using a default value in some situations.

Suppose that you want to find out the average salary for all employees in a department. The salary column does not always need to contain a meaningful value, so you can choose between the following options:

- Allowing null values for the SALARY column
- Using a non-null default value (such as, 0)

By allowing null values, you can formulate the query easily, and Db2 provides the average of all known or recorded salaries. The calculation does not include the rows that contain null values. In the second case, you probably get a misleading answer unless you know the nonnull default value for unknown salaries and formulate your query accordingly.

The following figure shows two scenarios. The table in the figure excludes salary data for employee number 200440, because the company just hired this employee and has not yet determined the salary. The calculation of the average salary for department E21 varies, depending on whether you use null values or nonnull default values.

- The left side of the figure assumes that you use null values. In this case, the calculation of average salary for department E21 includes only the three employees (000320, 000330, and 200340) for whom salary data is available.
- The right side of the figure assumes that you use a nonnull default value of zero (0). In this case, the calculation of average salary for department E21 includes all four employees, although valid salary information is available for only three employees.

As you can see, only the use of a null value results in an accurate average salary for department E21.

```
SELECT DEPT, AVG (SALARY)
FROM EMP
GROUP BY DEPT;
```

With null value

EMPNO	DEPT	SALARY
000320	E21	19950.00
000330	E21	25370.00
200340	E21	23840.00
200440	E21	-----

↓

DEPT	AVG (SALARY)
.....
·	·
·	·
·	·
E21	23053.33

(Average of nonnull salaries)

With default value of 0

EMPNO	DEPT	SALARY
000320	E21	19950.00
000330	E21	25370.00
200340	E21	23840.00
200440	E21	0.00

↓

DEPT	AVG (SALARY)
=====	=====
·	·
·	·
·	·
E21	17290.00

Figure 5. When nulls are preferable to default values

Null values are distinct in most situations so that two null values are not equal to each other.

Example

GUIP

The following example shows how to compare two columns to see if they are equal or if both columns are null:

```
WHERE E1.DEPT IS NOT DISTINCT FROM E2.DEPT
```

GUIP

Related concepts

[Null values in table columns \(Introduction to Db2 for z/OS\)](#)

[Default values for table columns \(Introduction to Db2 for z/OS\)](#)

[Assignment and comparison](#)

The basic operations of SQL are assignment and comparison.

Check constraints for column values

You can use check constraints to ensure that only values from the domain for the column or attribute are allowed.

By using check constraints, programmers can avoid developing, testing, and maintaining application code that performs these checks.

You can choose to define check constraints by using the SQL CREATE TABLE statement or ALTER TABLE statement. For example, you might want to ensure that each value in the SALARY column of the EMP table contains more than a certain minimum amount.

Db2 enforces a check constraint by applying the relevant search condition to each row that is inserted, updated, or loaded. An error occurs if the result of the search condition is false for any row.

Check constraints that insert table rows

When you use the INSERT statement or the MERGE statement to add a row to a table, Db2 automatically enforces all check constraints for that table. If the data violates any check constraint that is defined on that table, Db2 does not insert the row.

GUIP

Example 1

Assume that the NEWEMP table has the following two check constraints:

- Employees cannot receive a commission that is greater than their salary.
- Department numbers must be between '001' to '100,' inclusive.

Consider this INSERT statement, which adds an employee who has a salary of \$65,000 and a commission of \$6000:

```
INSERT INTO NEWEMP
(EMPNO, FIRSTNME, LASTNAME, DEPT, JOB, SALARY, COMM)
VALUES ('100125', 'MARY', 'SMITH', '055', 'SLS', 65000.00, 6000.00);
```

The INSERT statement in this example succeeds because it satisfies both constraints.

Example 2

Consider this INSERT statement:

```
INSERT INTO NEWEMP
(EMPNO, FIRSTNME, LASTNAME, DEPT, JOB, SALARY, COMM)
VALUES ('120026', 'JOHN', 'SMITH', '055', 'DES', 5000.00, 55000.00 );
```

The INSERT statement in this example fails because the \$55,000 commission is higher than the \$5,000 salary. This INSERT statement violates a check constraint on NEWEMP.

GUIP

Check constraints that update tables

Db2 automatically enforces all check constraints for a table when you use the UPDATE statement or the MERGE statement to change a row in the table. If the intended update violates any check constraint that is defined on that table, Db2 does not update the row.

GUIP

Example 1

Assume that the NEWEMP table has the following two check constraints:

- Employees cannot receive a commission that is greater than their salary.
- Department numbers must be between '001' to '100,' inclusive.

Consider this UPDATE statement:

```
UPDATE NEWEMP
SET DEPT = '011'
WHERE FIRSTNME = 'MARY' AND LASTNAME= 'SMITH';
```

This update succeeds because it satisfies the constraints that are defined on the NEWEMP table.

Example 2

Consider this UPDATE statement:

```
UPDATE NEWEMP
SET DEPT = '166'
WHERE FIRSTNME = 'MARY' AND LASTNAME= 'SMITH';
```

This update fails because the value of DEPT is '166,' which violates the check constraint on NEWEMP that DEPT values must be between '001' and '100.'



Related concepts

[Check constraints \(Db2 Application programming and SQL\)](#)

Related tasks

[Adding or dropping table check constraints \(Db2 Administration Guide\)](#)

Related reference

[CREATE TABLE statement](#)

The CREATE TABLE statement defines a table. The definition must include its name and the names and attributes of its columns. The definition can include other attributes of the table, such as its primary key and its table space.

Db2 indexes

An *index* is an ordered set of pointers to rows of a table. Db2 can use indexes to improve performance and ensure uniqueness. Understanding the structure of Db2 indexes can help you achieve the best performance for your system.

Conceptually, you can think of an index to the rows of a Db2 table like you think of an index to the pages of a book. Each index is based on the values of data in one or more columns of a table.

The main purpose of an index is to improve performance for access to the data. In most cases, access to data is faster with an index than with a scan of the data. For example, you can create an index on the DEPTNO column of the sample DEPT table so that Db2 can easily locate a specific department and avoid reading through each row of, or *scanning*, the table.

An index is stored separately from the data in the table. Each index is physically stored in its own index space. When you define an index by using the CREATE INDEX statement, Db2 builds this structure and maintains it automatically. However, you can perform necessary maintenance such as reorganizing it or recovering the index.

Another purpose of an index is to ensure uniqueness. For example, a unique index on the employee table ensures that no two employees have the same employee number.

In most cases, the users of an index are unaware that it is being used because Db2 decides whether to use the index to access the table.

Db2 supports simple indexes and extended indexes. An extended index is one of the following objects:

- An expression-based index
- A spatial index
- An XML index

Be aware that indexes have both benefits and disadvantages. A greater number of indexes can simultaneously improve the access performance of a particular transaction and require additional processing for inserting, updating, and deleting index keys.

Related concepts

[Creation of indexes \(Introduction to Db2 for z/OS\)](#)

Related reference

[CREATE INDEX statement](#)

The CREATE INDEX statement creates a partitioning index or a secondary index and an index space at the current server. The columns included in the key of the index are columns of a table at the current server.

Db2 views

A *view* is an alternative way of representing data that exists in one or more tables. A view can include all or some of the columns from one or more base tables.

A view is a named specification of a result table. Conceptually, creating a view is somewhat like using binoculars. You might look through binoculars to see an entire landscape or to look at a specific image within the landscape, such as a tree.

You can create Db2 views that achieve the following goals:

- Combines data from different base tables
- Based on other views or on a combination of views and tables
- Omit certain data, thereby shielding some table data from users

In fact, these are common underlying reasons to use a view. Combining information from base tables and views simplifies retrieving data for a user, and limiting the data that a user can see is useful for security. You can use views for a number of different purposes. A view can:

- Control access to a table
- Make data easier to use
- Simplify authorization by granting access to a view without granting access to the table
- Show only portions of data in the table
- Show summary data for a given table
- Combine two or more tables in meaningful ways
- Show only the selected rows that are pertinent to the process that uses the view

How to access data in Db2 views

To retrieve or access information from a view, you use views like you use base tables. You can use a SELECT statement to show the information from the view. The SELECT statement can name other views and tables, and it can use the WHERE, GROUP BY, and HAVING clauses. It cannot use the ORDER BY clause or name a host variable.

Whether a view can be used in an insert, update, or delete operation depends on its definition. For example, if a view includes a foreign key of its base table, INSERT and UPDATE operations that use the view are subject to the same referential constraint as the base table. Likewise, if the base table of a view is a parent table, DELETE operations that use the view are subject to the same rules as DELETE operations on the base table. *Read-only* views cannot be used for insert, update, and delete operations.

How to create Db2 views

To define a view, you use the CREATE VIEW statement and assign a name (up to 128 characters in length) to the view. Specifying the view in other SQL statements is effectively like running an SQL SELECT statement. At any time, the view consists of the rows that would result from the SELECT statement that it contains. You can think of a view as having columns and rows just like the base table on which the view is defined.

You also can specify a period specification for a view, subject to certain restrictions.

Examples of creating Db2 views



Example 1

The following figure shows a view of the EMP table that omits sensitive employee information and renames some of the columns.

Base table, **EMP**:

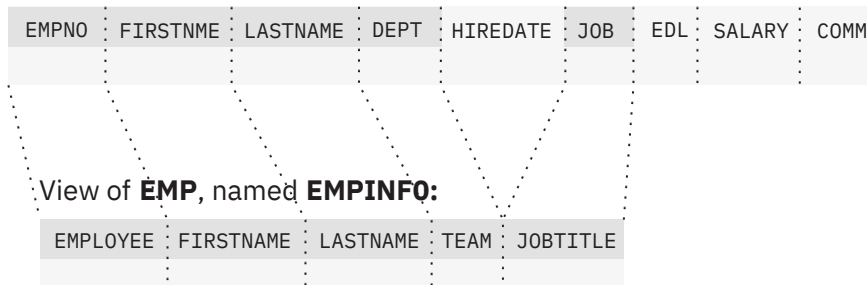

Figure 6. A view of the EMP table

Figure note: The EMPINFO view represents a table that includes columns named EMPLOYEE, FIRSTNAME, LASTNAME, TEAM, and JOBTITLE. The data in the view comes from the columns EMPNO, FIRSTNAME, LASTNAME, DEPT, and JOB of the EMP table.

Example 2

The following CREATE VIEW statement defines the EMPINFO view that is shown in the preceding figure:

```
CREATE VIEW EMPINFO (EMPLOYEE, FIRSTNAME, LASTNAME, TEAM, JOBTITLE)
AS SELECT EMPNO, FIRSTNAME, LASTNAME, DEPT, JOB
FROM EMP;
```

When you define a view, Db2 stores the definition of the view in the Db2 catalog. However, Db2 does not store any data for the view itself, because the data exists in the base table or tables.

Example 3

You can narrow the scope of the EMPINFO view by limiting the content to a subset of rows and columns that includes departments A00 and C01 only:

```
CREATE VIEW EMPINFO (EMPLOYEE, FIRSTNAME, LASTNAME, TEAM, JOBTITLE)
AS SELECT EMPNO, FIRSTNAME, LASTNAME, WORKDEPT, JOB
FROM EMP
WHERE WORKDEPT = 'A00' OR WORKDEPT = 'C01';
```

GUPI

In general, a view inherits the attributes of the object from which it is derived. Columns that are added to the tables after the view is defined on those tables do not appear in the view.

Restriction: You cannot create an index for a view. In addition, you cannot create any form of a key or a constraint (referential or otherwise) on a view. Such indexes, keys, or constraints must be built on the tables that the view references.

Related concepts

[Creation of views \(Introduction to Db2 for z/OS\)](#)

Related reference

[Employee table \(DSN8C10.EMP\) \(Introduction to Db2 for z/OS\)](#)

[CREATE VIEW statement](#)

The CREATE VIEW statement creates a view on tables or views at the current server.

[Views on the sample tables \(Introduction to Db2 for z/OS\)](#)

Related information

[Implementing Db2 views \(Db2 Administration Guide\)](#)

Aliases

An *alias* is a substitute for the three-part name of a table or view.

An alias can be defined at a local server and can refer to a table or view that is at the current server or a remote server. The alias name can be used wherever the table name or view name can be used to refer to the table or view in an SQL statement.

Suppose that data is occasionally moved from one Db2 subsystem to another. Ideally, users who query that data are not affected when this activity occurs. They always want to log on to the same system and access the same table or view, regardless of where the data resides. You can achieve this result by using an alias for an object name.

An alias can be a maximum of 128 characters, qualified by an owner ID. You use the CREATE ALIAS and DROP ALIAS statements to manage aliases.

GUIP For example, assume that you create an alias with the following statement:

```
CREATE ALIAS TESTTAB FOR USIBMSTODB22.IDEMP01.EMP;
```

If a user with the ID JONES dynamically creates the alias, JONES owns the alias, and you query the table like this:

```
SELECT SUM(SALARY), SUM(BONUS), SUM(COMM)
FROM JONES.TESTTAB;
```

GUIP

The object for which you are defining an alias does not need to exist when you execute the CREATE ALIAS statement. However, the object must exist when a statement that refers to the alias executes.

When you want an application to access a server other than the server that is specified by a location name, you do not need to change the location name. Instead, you can use a location alias to override the location name that an application uses to access a server. As a result, a Db2 for z/OS requester can access multiple Db2 databases that have the same name but different network addresses. Location aliases allow easier migration to a Db2 server and minimize application changes.

After you create an alias, anyone who has authority over the object that the alias is referencing can use that alias. A user does not need a separate privilege to use the alias.

Related reference

[CREATE ALIAS statement](#)

The CREATE ALIAS statement defines an alias for a table, a view, or a sequence. The definition is recorded in the Db2 catalog at the current server.

Triggers

A *trigger* defines a set of actions that are executed when a delete, insert, or update operation occurs on a specified table or view. When such an operation is executed, the trigger is said to be *activated*.

Db2 supports two types of triggers, basic and advanced:

- *Basic triggers* support a limited set of SQL statements, and require the MODE DB2SQL clause on the CREATE TRIGGER statement. You can identify basic triggers by querying the SYSIBM.SYSTRIGGERS catalog table. Blank values in the SQLPL column identify basic triggers. For more information, see [“CREATE TRIGGER statement \(basic trigger\)” on page 1769](#).
- *Advanced triggers* support a larger set of SQL statements, including SQL procedure language (SQL PL). A CREATE TRIGGER statement for an advanced trigger must not specify the MODE DB2SQL clause. Advanced triggers are supported at application compatibility level V12R1M500 or higher. You can identify advanced triggers by querying the SYSIBM.SYSTRIGGERS catalog table. 'Y' values in the SQLPL column identify advanced triggers. For more information about advanced triggers, see [“CREATE TRIGGER statement \(advanced trigger\)” on page 1740](#).

For a detailed comparison of the types, see [“Basic and advanced triggers”](#) on page 34.

You can use triggers along with referential constraints and check constraints to enforce data integrity rules. Triggers are more powerful than constraints because you can use them to do the following things:

- Update other tables
- Automatically generate or transform values for inserted or updated rows
- Invoke functions that perform operations both inside and outside of Db2

For example, assume that you need to prevent an update to a column when a new value exceeds a certain amount. Instead of preventing the update, you can use a trigger. The trigger can substitute a valid value and invoke a procedure that sends a notice to an administrator about the attempted invalid update.

You define triggers with the CREATE TRIGGER statement.

Triggers move the business rule application logic into the database, which results in faster application development and easier maintenance. The business rule is no longer repeated in several applications, and the rule is centralized to the trigger. For example, Db2 can check the validity of the changes that any application makes to a salary column, and you are not required to change application programs when the logic changes.

There are a number of criteria that are defined when creating a trigger, which are used to determine when a trigger should be activated.

- The *subject table* (also known as the triggering table) defines the table or view for which the trigger is defined.
- The *trigger event* defines a specific SQL operation that modifies the subject table. The operation could be a delete, insert, or update.
- The *trigger activation time* defines whether the trigger should be activated before or after the trigger event is performed on the subject table.

The statement that causes a trigger to be activated includes a set of *affected rows*. These are the rows of the subject table that are being deleted, inserted or updated. The *trigger granularity* defines whether the actions of the trigger are to be performed once for the statement, or once for each of the rows in the set of affected rows.

The *trigger action* consists of an optional search condition and a set of SQL statements that are executed whenever the trigger is activated. The SQL statements are only executed if no search condition is specified, or the specified search condition evaluates to true.

The triggered action can refer to the values in the set of affected rows. This is supported through the use of *transition variables*. Transition variables use the names of the columns in the subject table, qualified by a specified name that identifies whether the reference is to the old value (prior to the update) or the new value (after the update). The new value can also be changed using an assignment in a before update or insert trigger.

Another means of referring to the values in the set of affected rows is by using *transition tables*. Transition tables also use the names of the columns of the subject table, but have a name specified that allows the complete set of affected rows to be treated as a table. Transition tables can only be used in after triggers, and cannot be modified. Separate transition tables can be defined for old and new values.

Multiple triggers can be specified for a combination of table, event, or activation time. The order in which the triggers are activated is the same as the order in which they were created. Thus, the most recently created trigger is the last trigger that is activated.

The activation of a trigger might cause *trigger cascading*. This is the result of the activation of one trigger that executes SQL statements that cause the activation of other triggers, or even the same trigger again. The triggered actions might also cause updates as a result of the original modification, which might result in the activation of additional triggers. With trigger cascading, a significant chain of triggers might be activated, causing significant change to the database as a result of a single delete, insert or update statement.

The actions that are performed in the trigger are considered to be part of the operation that caused the trigger to be executed.

- The database manager ensures that the operation and the triggers that are executed as a result of that operation either all complete or are all backed out. Operations that occurred prior to the triggering operation are not affected.
- The database manager effectively checks all constraints (except for a constraint with a RESTRICT delete rule) after the operation and the associated triggers have been executed.

Basic and advanced triggers

Basic and advanced triggers offer different functionality. See the corresponding syntax diagrams for the CREATE TRIGGER (basic) and CREATE TRIGGER (advanced) SQL statements for more information. The following table identifies some behavioral differences between the two types of triggers.

Table 8. Behavioral differences of basic and advanced triggers

Behavior	Basic Trigger	Advanced Trigger
CREATE or ALTER TRIGGER statement invocation	CREATE or ALTER TRIGGER (basic) statement can be embedded in an application program or issued interactively. It is an executable statement that can be dynamically prepared only if DYNAMICRULES run behavior is implicitly or explicitly specified.	CREATE or ALTER TRIGGER (advanced) statement can be issued interactively. It is an executable statement that can be dynamically prepared only if DYNAMICRULES run behavior is implicitly or explicitly specified.
Authorization requirement	The privilege set must include SYSADM or the SELECT privilege on the table or view on which the trigger is defined, if the REFERENCING clause is included in the trigger definition.	The privilege set must include SYSADM or the SELECT privilege for the triggering table or view on which the trigger is defined.
Default encoding scheme	The default encoding scheme is Unicode.	The default encoding scheme is determined from the value of the DEFAULT APPLICATION ENCODING SCHEME field on the installation panel DSNTIPF.
Null attribute for transition variables	A transition variable is defined with the same null attribute as the column it is associated with.	All transition variables are nullable.
Unhandled warnings at completion of a trigger	Unhandled warnings are not returned to the statement that activated a trigger. When processing in a trigger completes with a warning, the warning is not returned to the statement that activated the trigger.	Unhandled warnings are returned to the statement that activated a trigger. When processing in a trigger completes with a warning, the warning is returned to the statement that activated the trigger.
Transition variables passed as OUT or INOUT arguments to a procedure	Changes to transition variables in a procedure are not visible on return to the invoking environment, and changes to transition variables (for an AFTER trigger) are not disallowed.	Changes to transition variables in a procedure are visible on return to the invoking environment, and changes to transition variables (for an AFTER trigger) are disallowed.
Stand-alone <i>fullselect</i> and VALUES statements	Supported.	Not supported. Use a SELECT INTO statement or VALUES INTO statement instead.

Related concepts

[Creation of triggers \(Introduction to Db2 for z/OS\)](#)

User-defined types

A *user-defined data type* is a data type that is defined to the database using a CREATE statement.

A user-defined data type is a distinct type or an array type.

A *distinct type* is a user-defined type that shares its internal representation with a built-in data type (its source type), but is considered to be a separate and incompatible data type for most operations. A distinct type is created with an SQL CREATE TYPE (distinct) statement. A distinct type can be used to define a column of a table, or a parameter of a routine.

An *array type* is a user-defined data type that consists of an ordered set of elements of a single built-in data type. Elements can be accessed and modified by their index position. An array type is created with an SQL CREATE TYPE (array) statement. An array type can be used as a parameter of an SQL routine, as a variable in an SQL routine, and as a global variable.

Related concepts

[Array types and values](#)

A user-defined *array type* is a data type that is defined as an array of elements. A user-defined array type can be either an *ordinary array* or *associative array*.

[Distinct types](#)

A *distinct type* is a user-defined data type that shares its internal representation with a built-in data type (its *source type*), but is considered to be a separate and incompatible data type for most operations.

Related reference

[CREATE TYPE statement](#)

The CREATE TYPE statement defines a user-defined data type at the current server.

Routines in Db2 for z/OS: functions and procedures

A *routine* is an executable SQL object. The two types of routines in Db2 for z/OS are functions and stored procedures.

Functions

A *function* is a routine that can be invoked from within other SQL statements and that returns a value or a table.

Functions are classified as either SQL functions or external functions. SQL functions are written using SQL statements, including SQL procedural language (SQL PL). External functions reference a host language program. The host language program can contain SQL, but does not require SQL.

You define functions by using the CREATE FUNCTION statement. You can classify functions as built-in functions, user-defined functions, or cast functions that are generated for distinct types. Functions can also be classified as aggregate, scalar, or table functions, depending on the input data values, result values, and the context in which they can be invoked.

For more information, see [“Functions” on page 237](#).

Procedures

A procedure, also known as a stored procedure, is a routine that you can call to perform operations that can include SQL statements.

Procedures are classified as either SQL procedures or external procedures. SQL procedures contain only SQL statements, including SQL procedural language (SQL PL). External procedures reference a host language program that might or might not contain SQL statements.

Db2 for z/OS supports the following types of procedures:

Native SQL procedures

The procedure body is written exclusively in SQL statements, including SQL procedural language (SQL PL) statements. The procedure body is contained and specified in the procedure definition along with various attributes of the procedure. A package is generated for a native SQL procedure. It contains the procedure body, including control statements. It might sometimes also include statements generated by Db2. Each time that the procedure is invoked, the package executes one or more times.

All SQL procedures that are created with a CREATE PROCEDURE statement that does not specify the FENCED or EXTERNAL options are native SQL procedures. More capabilities are supported for native SQL procedures, they usually perform better than external SQL procedures, and no associated C program is generated for them.

See [“CREATE PROCEDURE statement \(SQL - native procedure\)”](#) on page 1607.

External stored procedures

The procedure body is an external program that is written in a programming language such as C, C++, COBOL, or Java and it can contain SQL statements. The source code for an external stored procedure is separate from the procedure definition and is bound into a package. The name of the external executable is specified as part of the procedure definition along with various attributes of the procedure. All programs must be designed to run using Language Environment. Your COBOL and C++ stored procedures can contain object-oriented extensions. Each time that the stored procedure is invoked, the logic in the procedure controls whether the package executes and how many times.

For more information, see [Creating external stored procedures \(Db2 Application programming and SQL\)](#).

See [“CREATE PROCEDURE statement \(external procedure\)”](#) on page 1580.

External SQL procedures (deprecated)

The procedure body is written exclusively in SQL statements, including SQL procedural language (SQL PL) statements. The procedure body is specified in the procedure definition along with various attributes of the procedure. A C program and an associated package are generated for an external SQL procedure. It contains the procedure body, including control statements. It might sometimes also include statements generated by Db2. Each time that the procedure is invoked, the package executes one or more times.

Native SQL procedures are more fully supported, easier to maintain, and typically perform better than external SQL procedures, which are deprecated.

See [“CREATE PROCEDURE statement \(SQL - external procedure\) \(deprecated\)”](#) on page 1597.

SQL control statements are supported in SQL procedures. Control statements are SQL statements that allow SQL to be used in a manner similar to writing a program in a structured programming language. SQL control statements provide the capability to control the logic flow, declare and set variables, and handle warnings and exceptions. Some SQL control statements include other nested SQL statements.

SQL procedures provide the same benefits as procedures in a host language. That is, a common piece of code needs to be written and maintained only once and can be called from several programs.

SQL procedures provide additional benefits when they contain SQL statements. In this case, SQL procedures can reduce or eliminate network delays that are associated with communication between the client and server and between each SQL statement. SQL procedures can improve security by providing a user the ability to invoke only a procedure instead of providing them with the ability to execute the SQL that the procedure contains.

You define procedures by using the CREATE PROCEDURE statement.

Related concepts

[Functions](#)

A *function* is an operation denoted by a function name followed by zero or more operands that are enclosed in parentheses. It represents a relationship between a set of input values and a set of result values.

[Creation of user-defined functions \(Introduction to Db2 for z/OS\)](#)

[Use of an application program as a stored procedure \(Introduction to Db2 for z/OS\)](#)

[External stored procedures \(Db2 Application programming and SQL\)](#)

[SQL control statements for external SQL procedures](#)

SQL control statements for external SQL procedures can be used only with SQL procedures that are created with the `FENCED` or `EXTERNAL` clause. *SQL control statements* provide the capability to control the logic flow, declare and set variables, and handle warnings and exceptions. Some SQL control statements include other nested SQL statements.

[SQL procedural language \(SQL PL\)](#)

Related tasks

[Creating a user-defined function \(Db2 Application programming and SQL\)](#)

[Implementing Db2 stored procedures \(Stored procedures provided by Db2\)](#)

Related reference

[Procedures that are supplied with Db2](#)

A *procedure* is an application program that can be started through the SQL `CALL` statement. The procedure is specified by a procedure name, which may be followed by arguments that are enclosed within parentheses. This information contains syntax diagrams, semantic descriptions, rules, and examples of the use of the system supplied procedures.

Sequences

A *sequence* is a stored object that simply generates a sequence of numbers in a monotonically ascending (or descending) order. A sequence provides a way to have Db2 automatically generate unique integer primary keys and to coordinate keys across multiple rows and tables.

A sequence can be used to exploit parallelization, instead of programmatically generating unique numbers by locking the most recently used value and then incrementing it.

Sequences are ideally suited to the task of generating unique key values. One sequence can be used for many tables, or a separate sequence can be created for each table requiring generated keys. A sequence has the following properties:

- Guaranteed, unique values, assuming that the sequence is not reset and does not allow the values to cycle
- Monotonically increasing or decreasing values within a defined range
- Can increment with a value other than 1 between consecutive values (the default is 1).
- Recoverable. If Db2 should fail, the sequence is reconstructed from the logs so that Db2 guarantees that unique sequence values continue to be generated across a Db2 failure.

Values for a given sequence are automatically generated by Db2. Use of Db2 sequences avoids the performance bottleneck that results when an application implements sequences outside the database. The counter for the sequence is incremented (or decremented) independently of the transaction. In some cases, gaps can be introduced in a sequence. A gap can occur when a given transaction increments a sequence two times. The transaction might see a gap in the two numbers that are generated because there can be other transactions concurrently incrementing the same sequence. A user might not realize that other users are drawing from the same sequence. Furthermore, it is possible that a given sequence can appear to have generated gaps in the numbers, because a transaction that might have generated a sequence number might have rolled back or the Db2 subsystem might have failed. Updating a sequence is not part of a transaction's unit of recovery.

A sequence is created with a `CREATE SEQUENCE` statement. A sequence can be referenced using a *sequence-reference*. A sequence reference can appear most places that an expression can appear. A sequence reference can specify whether the value to be returned is a newly generated value, or the previously generated value.

Although there are similarities, a sequence is different than an identity column. A sequence is an object, whereas an identity column is a part of a table. A sequence can be used with multiple tables, but an identity column is tied to a single table.

Related reference

[CREATE SEQUENCE statement](#)

The CREATE SEQUENCE statement creates a sequence at the current server.

Db2 system objects

Unlike the Db2 data structures that users create and access, Db2 controls and accesses system objects.

Db2 has a comprehensive infrastructure that enables it to provide data integrity, performance, and the ability to recover user data. In addition, Parallel Sysplex® data sharing uses shared system objects.

Related concepts

[Db2 database objects overview \(Introduction to Db2 for z/OS\)](#)

Db2 catalog

Db2 maintains a set of tables that contain information about the data that Db2 controls. These tables are collectively known as the *catalog*.

The catalog tables contain information about Db2 objects such as tables, views, and indexes. When you create, alter, or drop an object, Db2 inserts, updates, or deletes rows of the catalog that describe the object.

The Db2 catalog consists of tables of data about everything defined to the Db2 system, including table spaces, indexes, tables, copies of table spaces and indexes, and storage groups. The system database DSNDBO6 contains the Db2 catalog.

When you create, alter, or drop any structure, Db2 inserts, updates, or deletes rows of the catalog that describe the structure and tell how the structure relates to other structures. For example, SYSIBM.SYSTABLES is one catalog table that records information when a table is created. Db2 inserts a row into SYSIBM.SYSTABLES that includes the table name, its owner, its creator, and the name of its table space and its database.

To understand the role of the catalog, consider what happens when the EMP table is created. Db2 records the following data:

Table information

To record the table name and the name of its owner, its creator, its type, the name of its table space, and the name of its database, Db2 inserts a row into the catalog.

Column information

To record information about each column of the table, Db2 inserts the name of the table to which the column belongs, its length, its data type, and its sequence number by inserting a row into the catalog for each column of the table.

Authorization information

To record that the owner of the table has authorization to create the table, Db2 inserts a row into the catalog.

Tables in the catalog are like any other database tables with respect to retrieval. If you have authorization, you can use SQL statements to look at data in the catalog tables in the same way that you retrieve data from any other table in the Db2 database. Db2 ensures that the catalog contains accurate object descriptions. If you are authorized to access the specific tables or views on the catalog, you can use SELECT on the catalog. You can use INSERT, UPDATE, and DELETE statements on updatable catalog tables, but you cannot use TRUNCATE or MERGE on the catalog.

The *communications database* (CDB) is part of the Db2 catalog. The CDB consists of a set of tables that establish conversations with remote database management systems (DBMSs). The distributed data facility (DDF) uses the CDB to send and receive distributed data requests.

Tip: For best results, check the consistency of the Db2 catalog and directory regularly, even outside of the migration process. For detailed instructions, see [Verify the integrity of Db2 table spaces](#) and [Check for consistency between catalog tables](#).

Related reference

Db2 catalog tables

Db2 for z/OS maintains a set of tables (in database DSNDB06) called the Db2 catalog.

Db2 directory

The Db2 directory contains information that Db2 uses during normal operation.

You can use SQL to retrieve data only from the directory tables that are listed in [Appendix I, “Db2 directory tables,”](#) on page 2769. You can submit queries against the Db2 catalog for Db2 directory objects.

The directory consists of a set of Db2 tables that are stored in table spaces in system database DSNDB01. Each of the table spaces that are listed in the following table is contained in a VSAM linear data set.

Table 9. Directory table spaces

Table space name	Description
SCT02	Contains the internal form of SQL statements that are contained in an application. If you bound a plan with SQL statements in a prior release, Db2 created a structure in SCT02.
SPT01 Skeleton package	Contains the internal form of SQL statements that are contained in a package.
SYSSPUXA	Contains the contents of a package selection.
SYSSPUBX	Contains the contents of a package explain block.
SYSLGRNX Log range	Tracks the opening and closing of table spaces, indexes, or partitions. By tracking this information and associating it with relative byte addresses (RBAs) as contained in the Db2 log, Db2 can reduce recovery time by reducing the amount of log that must be scanned for a particular table space, index, or partition.
SYSUTILX System utilities	Contains a row for every utility job that is running. The row persists until the utility is finished. If the utility terminates without completing, Db2 uses the information in the row when you restart the utility.
DBD01 Database descriptor (DBD)	Contains internal information, called <i>database descriptors</i> (DBDs), about the databases that exist within the Db2 subsystem. Each database has exactly one corresponding DBD that describes the database, table spaces, tables, table check constraints, indexes, and referential relationships. A DBD also contains other information about accessing tables in the database. Db2 creates and updates DBDs whenever their corresponding databases are created or updated.
SYSDBXA	Contains the contents of a DBD section.

Tip: For best results, check the consistency of the Db2 catalog and directory regularly, even outside of the migration process. For detailed instructions, see [Verify the integrity of Db2 table spaces](#) and [Check for consistency between catalog tables](#).

Active and archive logs

Db2 records all data changes and other significant events in a log.

If you keep these logs, Db2 can re-create those changes for you in the event of a failure or roll the changes back to a previous point in time.

Db2 writes each log record to a disk data set called the *active log*. When the active log is full, Db2 copies the contents of the active log to a disk or magnetic tape data set called the *archive log*.

You can choose either single logging or dual logging.

- A single active log contains up to 93 active log data sets.
- With dual logging, the active log has twice the capacity for active log data sets, because two identical copies of the log records are kept.

Each Db2 subsystem manages multiple active logs and archive logs. The following facts are true about each Db2 active log:

- Each log can be duplexed to ensure high availability.
- Each active log data set is a VSAM linear data set (LDS).
- Db2 supports striped active log data sets, however striping is generally unnecessary with the latest devices, and is not recommended in most cases.

Important: Do not use striped active logs for disaster recovery.

Related tasks

[Managing the log and the bootstrap data set \(Db2 Administration Guide\)](#)

[Improving Db2 log performance \(Db2 Performance\)](#)

Related information

[Reading log records \(Db2 Administration Guide\)](#)

Bootstrap data set

The *bootstrap data set (BSDS)* is a VSAM key-sequenced data set (KSDS). This KSDS contains information that is critical to Db2, such as the names of the logs. Db2 uses information in the BSDS for system restarts and for any activity that requires reading the log.

Specifically, the BSDS contains:

- An inventory of all active and archive log data sets that are known to Db2. Db2 uses this information to track the active and archive log data sets. Db2 also uses this information to locate log records to satisfy log read requests during normal Db2 system activity and during restart and recovery processing.
- A wrap-around inventory of all recent Db2 checkpoint activity. Db2 uses this information during restart processing.
- The distributed data facility (DDF) communication record, which contains information that is necessary to use Db2 as a distributed server or requester.
- Information about buffer pools.

Because the BSDS is essential to recovery in the event of subsystem failure, during installation Db2 automatically creates two copies of the BSDS and, if space permits, places them on separate volumes.

The BSDS can be duplexed to ensure availability.

For instructions, see [Convert BSDS records to the extended 10-byte format: DSNTIJCB \(Db2 Installation and Migration\)](#).

Related tasks

[Managing the log and the bootstrap data set \(Db2 Administration Guide\)](#)

[Convert BSDS records to the extended 10-byte format: DSNTIJCB \(Db2 Installation and Migration\)](#)

Buffer pools

Buffer pools are areas of virtual storage that temporarily store pages of table spaces or indexes.

When an application program accesses a row of a table, Db2 places the page that contains that row in a buffer. Access to data in this temporary storage is faster than accessing data on a disk. If the required data is already in a buffer, the application program does not need to wait for it to be retrieved from disk, so the time and cost of retrieving the page is reduced.

Buffer pools require monitoring and tuning. Buffer pool sizes are critical to the performance characteristics of an application or group of applications that access data in those buffer pools.

You can specify default buffer pools for user data and for indexes. A special type of buffer pool that is used only in Parallel Sysplex data sharing is the *group buffer pool*, which resides in the coupling facility. Group buffer pools reside in a special PR/SM LPAR logical partition called a *coupling facility*, which enables several Db2 subsystems to share information and control the coherency of data.

Buffer pools reside in the database services address space (*ssnmDBM1*). The maximum size of a buffer pool is 16 TB.

Related concepts

[The role of buffer pools in caching data \(Introduction to Db2 for z/OS\)](#)

Related tasks

[Tuning database buffer pools \(Db2 Performance\)](#)

[Calculating buffer pool size \(Db2 Installation and Migration\)](#)

[Enabling automatic buffer pool size management \(Db2 Performance\)](#)

Data definition control support database

The *data definition control support* (DDCS) database refers to a user-maintained collection of tables that are used by data definition control support to restrict the submission of specific Db2 DDL (data definition language) statements to selected application identifiers (plans or collections of packages).

This database is automatically created during installation. After this database is created, you must populate the tables to use this facility. The system name for this database is DSNRGFDB.

The resource limit facility

The *resource limit facility* (sometimes abbreviated RLF) enables you to control the amount of processor resources that are used by SQL statements.

GUI

Resource limits apply to the following types of SQL statements:

- SELECT
- INSERT
- UPDATE
- MERGE
- TRUNCATE
- DELETE

You can specify resource limits for dynamic SQL statements and static SQL statements. Resource limits apply to SQL statement regardless of whether they are issued locally or remotely. The resource limit facility does not apply to primary or secondary authorization IDs that have installation SYSADM or installation SYSOPR authority.

You can establish a single limit for all users, different limits for individual users, or both. You can choose to have these limits applied before the statement is executed through *predictive governing*, or while a statement is running, through *reactive governing*. You can also use reactive and predictive governing

in combination. You define these limits in one or more *resource limit tables*, named DSNRLSTxx or DSNRLMTxx, depending on the monitoring purpose. 

Related concepts

[Resource limit facility controls \(Db2 Performance\)](#)

Related tasks

[Setting limits for system resource usage by using the resource limit facility \(Db2 Performance\)](#)

Related reference

[Resource limit facility tables \(Db2 Performance\)](#)

[-START RLIMIT command \(Db2\) \(Db2 Commands\)](#)

Work file database

Use the *work file database* as storage for processing SQL statements that require working space, such as that required for a sort.

The work file database is used as storage for Db2 work files for processing SQL statements that require working space (such as the space that is required for a sort), and as storage for created global temporary tables and declared global temporary tables.

Db2 creates a work file database and some table spaces in it for you at installation time. You can create additional work file table spaces at any time. You can drop, re-create, and alter the work file database or the table spaces in it, or both, at any time.

In a non-data-sharing environment, the work file database is named DSNDB07. In a data sharing environment, each Db2 member in the data sharing group has its own work file database.

You can also use the work file database for all temporary tables.

Related concepts

[How sort work files are allocated \(Db2 Performance\)](#)

Related reference

[SEPARATE WORK FILES field \(WFDBSEP subsystem parameter\) \(Db2 Installation and Migration\)](#)

Application processes and transactions

An application process involves running one or more programs. Different application processes might involve running different programs or running the same program at different times. When an application interacts with a Db2 database, a transaction begins.

Many different types of programs access Db2 data: user-written applications, SQL statements that users enter dynamically, and even utilities. The single term that describes any type of access to Db2 data is called an *application process*. All SQL programs run as part of an application process.

A *transaction* is a sequence of actions between the application and the database; the sequence begins when data in the database is read or written. A transaction is also known as a *unit of work*.

For example, Consider what happens when you access funds in a bank account. A banking transaction might involve the transfer of funds from one account to another. During the transaction, an application program first subtracts the funds from the first account, and then it adds the funds to the second account. Following the subtraction step, the data is inconsistent. Consistency is reestablished after the funds are added to the second account.

To ensure data consistency, Db2 uses a variety of techniques that include a commit operation, a rollback operation, and locking.

When the subtraction and addition steps of the banking transaction are complete, the application can use the commit operation to end the transaction, thereby making the changes available to other application processes. The *commit* operation makes the database changes permanent.

Consider what happens if more than one application process requests access to the same data at the same time. Or, under certain circumstances, an SQL statement might run concurrently with a utility on

the same table space. Db2 uses locks to maintain data integrity under these conditions to prevent, for example, two application processes from updating the same row of data simultaneously.

Db2 acquires locks to prevent uncommitted changes that are made by one application process from being perceived by any other. Db2 automatically releases all locks that it has acquired on behalf of an application process when that process ends, but an application process can also explicitly request that locks be released sooner. A commit operation releases locks that an application process has acquired and commits database changes that were made by the same process.

Db2 also provides a way to *back out* uncommitted changes that an application process makes. A back out might be necessary in the event of a failure on the part of an application process or in a *deadlock* situation. Deadlock occurs when contention for the use of a resource, such as a table, cannot be resolved. An application process, however, can explicitly request that its database changes be backed out. This operation is called *rollback*. The interface that an SQL program uses to explicitly specify these commit and rollback operations depends on the environment. For example, in the JDBC environment, applications use commit and rollback methods to commit or roll back transactions.

Related concepts

[Programming for Db2 for z/OS \(Introduction to Db2 for z/OS\)](#)

Application processes, concurrency, and recovery

All SQL programs execute as part of an *application process*. An application process involves the execution of one or more programs, and it is the unit to which Db2 allocates resources and locks.

Different application processes might involve the execution of different programs, or different executions of the same program. The means of initiating and terminating an application process are dependent on the environment.

Locking, commit, and rollback

More than one application process might request access to the same data at the same time. Furthermore, under certain circumstances, an SQL statement can execute concurrently with a utility on the same table space. *Locking* is used to maintain data integrity under such conditions, preventing, for example, two application processes from updating the same row of data simultaneously.

Db2 implicitly acquires locks to prevent uncommitted changes made by one application process from being perceived by any other. Db2 will implicitly release all locks it has acquired on behalf of an application process when that process ends, but an application process can also explicitly request that locks be released sooner. A *commit* operation releases locks acquired by the application process and commits database changes made by the same process.

Db2 provides a way to *back out* uncommitted changes made by an application process. This might be necessary in the event of a failure on the part of an application process, or in a *deadlock* situation. An application process, however, can explicitly request that its database changes be backed out. This operation is called *rollback*.

The interface used by an SQL program to explicitly specify these commit and rollback operations depends on the environment. If the environment can include recoverable resources other than Db2 databases, the SQL COMMIT and ROLLBACK statements cannot be used. Thus, these statements cannot be used in an IMS, CICS, or WebSphere environment.

Unit of work

A *unit of work* is a recoverable sequence of operations within an application process. A unit of work is sometimes called a *logical unit of work*.

At any time, an application process has a single unit of work, but the life of an application process can involve many units of work as a result of commit or full rollback operations.

A unit of work is initiated when an application process is initiated. A unit of work is also initiated when the previous unit of work is ended by something other than the end of the application process. A unit of work is ended by a commit operation, a full rollback operation, or the end of an application process. A commit or rollback operation affects only the database changes made within the unit of work it ends. While

these changes remain uncommitted, other application processes are unable to perceive them unless they are running with an isolation level of uncommitted read. The changes can still be backed out. Once committed, these database changes are accessible by other application processes and can no longer be backed out by a rollback. Locks acquired by Db2 on behalf of an application process that protects uncommitted data are held at least until the end of a unit of work.

The initiation and termination of a unit of work define *points of consistency* within an application process. A point of consistency is a claim by the application that the data is consistent. For example, a banking transaction might involve the transfer of funds from one account to another. Such a transaction would require that these funds be subtracted from the first account, and added to the second. Following the subtraction step, the data is inconsistent. Only after the funds have been added to the second account is consistency reestablished. When both steps are complete, the commit operation can be used to end the unit of work, thereby making the changes available to other application processes. The following figure illustrates this concept.

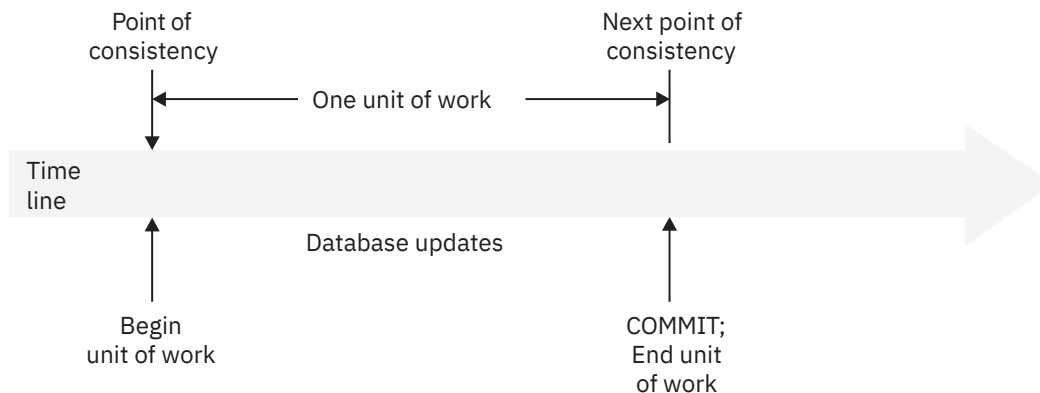

Figure 7. Unit of work with a commit operation

Unit of recovery

A Db2 unit of recovery is a recoverable sequence of operations executed by Db2 for an application process.

If a unit of work involves changes to other recoverable resources, the unit of work will be supported by other units of recovery. If relational databases are the only recoverable resources used by the application process, then the scope of the unit of work and the unit of recovery are the same and either term can be used.

Rolling back work

Db2 can back out all changes made in a unit of recovery or only selected changes. Only backing out all changes results in a point of consistency.

Rolling back all changes

The SQL ROLLBACK statement without the TO SAVEPOINT clause specified causes a full rollback operation. If such a rollback operation is successfully executed, Db2 backs out uncommitted changes to restore the data consistency that existed when the unit of work was initiated.

That is, Db2 undoes the work, as shown in the following figure:

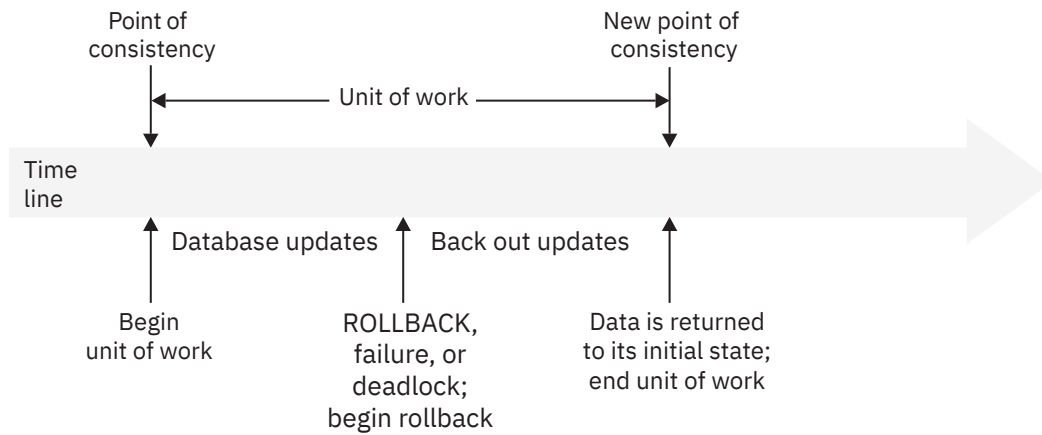

Figure 8. Rolling back all changes from a unit of work

Rolling back selected changes using savepoints

A *savepoint* represents the state of data at some particular time during a unit of work. An application process can set savepoints within a unit of work, and then as logic dictates, roll back only the changes that were made after a savepoint was set.

For example, part of a reservation transaction might involve booking an airline flight and then a hotel room. If a flight gets reserved but a hotel room cannot be reserved, the application process might want to undo the flight reservation without undoing any database changes made in the transaction prior to making the flight reservation. SQL programs can use the SQL `SAVEPOINT` statement to set savepoints, the SQL `ROLLBACK` statement with the `TO SAVEPOINT` clause to undo changes to a specific savepoint or the last savepoint that was set, and the SQL `RELEASE SAVEPOINT` statement to delete a savepoint. The following figure illustrates this concept.

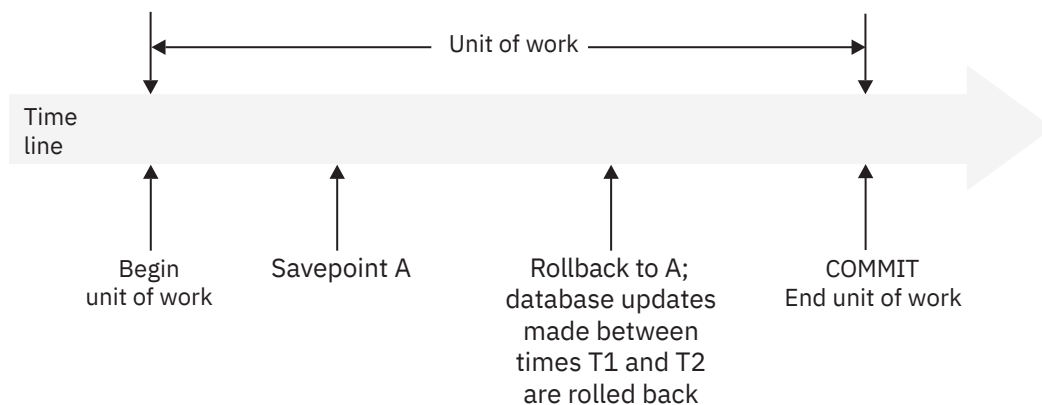

Figure 9. Rolling back changes to a savepoint within a unit of work

Packages and application plans

A *package* contains control structures that Db2 uses when it runs SQL statements. An *application plan* relates an application process to a local instance of Db2 and specifies processing options.

Packages are produced during program preparation. You can think of the control structures as the bound or operational form of SQL statements. All control structures in a package are derived from the SQL statements that are embedded in a single source program.

An application plan contains a list of package names.

Db2 applications require an application plan. Packages make application programs more flexible and easier to maintain.

In general, you create plans and packages by using the Db2 commands `BIND PLAN` and `BIND PACKAGE`.

Example

The following figure shows an application plan that contains two packages. Suppose that you decide to change the SELECT statement in package AA to select data from a different table. In this case, you need to bind only package AA again and not package AB.

GUI

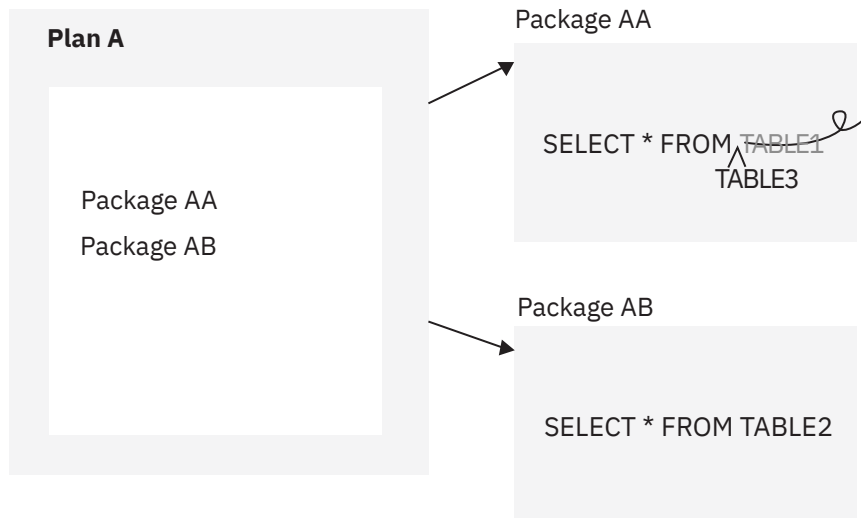

Figure 10. Application plan and packages

GUI

Packages for triggers and routines

A *trigger package* is a special type of package that is created when you issue a CREATE TRIGGER statement. It contains the trigger body and the WHEN clause for the trigger. When the trigger activates, the package executes one or more times.

Packages are also generated, or explicitly created for certain SQL routines, including stored procedures and certain types of user defined functions. The package for a routine contains the routine body, including control statements. The package might also contain statements that are generated by Db2. Each time that the routine is invoked, the package executes one or more times.

Specifically, Db2 generates a package automatically for the following types of SQL routines:

- External scalar functions
- External table functions
- Compiled SQL scalar functions
- Native SQL procedures
- External SQL procedures

For external stored procedures, you explicitly bind the source code for the stored procedure into a package before or you issue the CREATE PROCEDURE statement. Each time that the external procedure is invoked, the package executes one or more times.

Packages for JDBC, SQLJ, and ODBC applications

Packages for JDBC, SQLJ, and ODBC applications serve different purposes. For more information, see [Preparing and running JDBC and SQLJ programs \(Db2 Application Programming for Java\)](#) and [Db2 ODBC run time environment setup \(Db2 Programming for ODBC\)](#).

Related concepts

[Programming for Db2 for z/OS \(Introduction to Db2 for z/OS\)](#)

[Preparation process for an application program \(Introduction to Db2 for z/OS\)](#)

Related reference

[SET CURRENT PACKAGE PATH statement](#)

The SET CURRENT PACKAGE PATH statement assigns a value to the CURRENT PACKAGE PATH special register.

[SET CURRENT PACKAGESET statement](#)

The SET CURRENT PACKAGESET statement assigns a value to the CURRENT PACKAGESET special register.

[CREATE FUNCTION statement \(overview\)](#)

The CREATE FUNCTION statement registers a user-defined function with a database server. Each type of function that you can register with this statement is described separately.

[CREATE PROCEDURE statement \(overview\)](#)

The CREATE PROCEDURE statement registers a stored procedure with a database server. You can register the following types of procedures with this statement, each of which is described separately.

[CREATE TRIGGER statement \(basic trigger\)](#)

Subsystem parameters

Subsystem parameters are settings that apply to a Db2 for z/OS subsystem. For example, the AUTH subsystem parameter controls whether Db2 checks authorizations. Many users colloquially refer to subsystem parameters as *zparms*.

Generally, system administrators set the value of subsystem parameters when they install or migrate Db2. After installation or migration, a system administrator can change the values of subsystem parameters if needed. However, because these parameters can affect the entire subsystem, system administrators should first carefully evaluate and plan for the impact of any changed values. In some cases, changing the value of a subsystem parameter requires Db2 to be stopped and restarted.

Most subsystem parameters are listed on installation panels. However, some parameters are not. For a list of subsystem parameters, including those parameters that are not on panels, see [Directory of subsystem parameters, panel fields, and application default values \(Db2 Installation and Migration\)](#). This list includes important characteristics of each parameter, including whether changing a the parameter requires you to stop and restart Db2.

Subsystem parameter values are contained in a load module that is generated by installation job DSNTIJUZ. The name of this subsystem parameters load module is specified in the PARAMETER MODULE field of installation panel DSNTIPO3. The default name is DSNZPARM. However, to avoid naming conflicts with other members, you should use a different name. Sometimes the naming convention DSNZPxxx is used. In a data sharing environment, each member must have its own subsystem parameter load module.

One way to check the subsystem parameter values is to call stored procedure SYSPROC.ADMIN_INFO_SYSPARM by running sample job DSNTEJ6Z.

Some Db2 subsystem parameters are considered *security parameters*. These parameters can be updated only by processes with a privilege set that includes installation SYSADM authority or SECADM authority. For more information, see [Security parameters in Db2 for z/OS \(Db2 Installation and Migration\)](#).

Related concepts

[Subsystem parameters and application defaults in a data sharing environment \(Db2 Installation and Migration\)](#)

[Application programming default values \(Introduction to Db2 for z/OS\)](#)

[The Db2 installation CLIST panel session \(Db2 Installation and Migration\)](#)

Related reference

[PARAMETER MODULE field \(Db2 Installation and Migration\)](#)

Storage structures

In Db2, a *storage structure* is a set of one or more VSAM data sets that hold Db2 tables or indexes. A storage structure is also called a *page set*.

The two primary types of storage structures in Db2 for z/OS are table spaces and index spaces.

Related concepts

[Db2 database objects overview \(Introduction to Db2 for z/OS\)](#)

[Implementing Db2 indexes \(Db2 Administration Guide\)](#)

Related information

[Implementing Db2 table spaces \(Db2 Administration Guide\)](#)

Db2 databases

Db2 *databases* are a set of Db2 structures that include a collection of tables, their associated indexes, and the table spaces in which they reside. You define a database by using the CREATE DATABASE statement.

Whenever a table space is created, it is explicitly or implicitly assigned to an existing database. If you create a table space and do not specify a database name, the table space is created in the default database, DSNDB04. In this case, Db2 implicitly creates a database or uses an existing implicitly created database for the table. All users who have the authority to create table spaces or tables in database DSNDB04 have authority to create tables and table spaces in an implicitly created database. If the table space is implicitly created, and you do not specify the IN clause in the CREATE TABLE statement, Db2 implicitly creates the database to which the table space is assigned.

A single database, for example, can contain all the data that is associated with one application or with a group of related applications. Collecting that data into one database allows you to start or stop access to all the data in one operation. You can also grant authorization for access to all the data as a single unit. Assuming that you are authorized to access data, you can access data that is stored in different databases.

Generally, it is best to minimize the number of table spaces in each database. For the recommended partition-by-range and partition-by-growth table space types, each table space contains only a single table. However, if you do use multi-table segmented (non-UTS) table spaces, which are deprecated, minimize the number of tables in each table space. Too many table spaces and tables in a database can cause decreases in performance and manageability issues. If you reduce the number of table spaces and tables in a database, you improve performance, minimize maintenance, increase concurrency, and decrease log volume.

Deprecated function: FL 504 Non-UTS table spaces for base tables are deprecated. CREATE TABLESPACE statements that run at application compatibility level V12R1M504 or higher always create a partition-by-growth or partition-by-range table space, and CREATE TABLE statements that specify a non-UTS table space (including existing multi-table segmented table spaces) return an error. However, you can use a lower application compatibility level to create table spaces of the deprecated types if needed, such as for recovery situations. For instructions, see [Creating non-UTS table spaces \(deprecated\) \(Db2 Administration Guide\)](#).

The following figure shows how the main Db2 data structures fit together. Two databases, A and B, are represented as squares. Each database contains a table space and index space. Each index space contains one index. In database B, the table space is partitioned and contains table B1, partitions 1–4. The index space contains one partitioning index, parts 1–4.

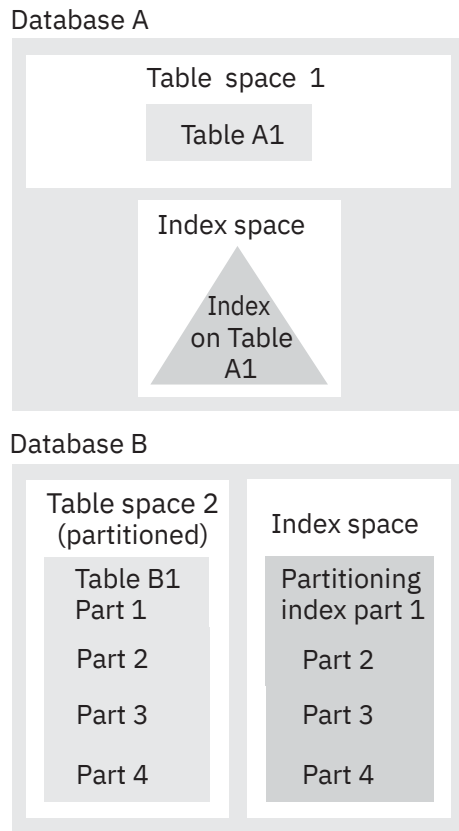

Figure 11. Data structures in a Db2 database

When you migrate Db2 12, Db2 adopts the default database and default storage group that you used in the previous version. You have the same authority for the Db2 12 as you did in the previous version.

Reasons to define a database

In Db2 for z/OS, a database is a logical collection of table spaces and index spaces. Consider the following factors when deciding whether to define a new database for a new set of objects:

- You can start and stop an entire database as a unit; you can display the statuses of all its objects by using a single command that names only the database. Therefore, place a set of tables that are used together into the same database. (The same database holds all indexes on those tables.)
- Some operations lock an entire database. For example, some phases of the LOAD utility prevent some SQL statements (CREATE, ALTER, and DROP) from using the same database concurrently. Therefore, placing many unrelated tables in a single database is often inconvenient.

When one user is executing a CREATE, ALTER, or DROP statement for a table, no other user can access the database that contains that table. QMF users, especially, might do a great deal of data definition; the QMF operations SAVE DATA and ERASE *data-object* are accomplished by creating and dropping Db2 tables. For maximum concurrency, create a separate database for each QMF user.

- The internal database descriptors (DBDs) might become inconveniently large. DBDs grow as new objects are defined, but they do not immediately shrink when objects are dropped; the DBD space for a dropped object is not reclaimed until the MODIFY RECOVERY utility is used to delete records of obsolete copies from SYSIBM.SYSCOPY. DBDs occupy storage and are the objects of occasional input and output operations. Therefore, limiting the size of DBDs is another reason to define new databases.

Related concepts

[Creation of databases \(Introduction to Db2 for z/OS\)](#)

Db2 table spaces

A Db2 *table space* is a set of volumes on disks that hold the data sets in which tables are actually stored. Every table is stored in table space.

A table space consists of a number of VSAM linear data sets. Table spaces are divided into equal-sized units, called *pages*. Each page is read from disk to the assigned buffer pool, or written from the buffer pool to disk, in a single operation. The page size is controlled by the buffer pool that you assign to the table space (4 KB, 8 KB, 16 KB, or 32 KB in size) for the data. The default page size is 4 KB.

Data in most table spaces can be compressed, which can allow you to store more data on each data page.

You can let Db2 create and manage the table space for you by issuing a CREATE TABLE statement that does not specify an existing table space. Db2 creates a partition-by-growth or partition-by-range table space. For more information, see [Creation of table spaces \(Introduction to Db2 for z/OS\)](#).

You can also explicitly define table spaces by issuing CREATE TABLESPACE statements. You specify the database that the table space belongs to, and the storage group that it uses. When you create a table space, certain options that you specify control the type of table space that is created.

Deprecated function: [FL 504 Non-UTS table spaces for base tables](#) are deprecated. CREATE TABLESPACE statements that run at application compatibility level V12R1M504 or higher always create a partition-by-growth or partition-by-range table space, and CREATE TABLE statements that specify a non-UTS table space (including existing multi-table segmented table spaces) return an error. However, you can use a lower application compatibility level to create table spaces of the deprecated types if needed, such as for recovery situations. For instructions, see [Creating non-UTS table spaces \(deprecated\) \(Db2 Administration Guide\)](#).

For descriptions of the various table space types, see [Table space types and characteristics in Db2 for z/OS \(Db2 Administration Guide\)](#).

Segmented non-UTS table spaces, which are deprecated, can contain more than one table. However, with the recommended partition-by-growth and partition-by-range table spaces, each table space contains only a single table.

Related tasks

[Creating table spaces explicitly \(Db2 Administration Guide\)](#)

[Choosing data page sizes \(Db2 Performance\)](#)

Related reference

[ALTER TABLESPACE statement](#)

The ALTER TABLESPACE statement changes the description of a table space at the current server.

[CREATE TABLESPACE statement](#)

The CREATE TABLESPACE statement defines a table space at the current server. The type of table space depends on the keywords specified.

Related information

[Implementing Db2 table spaces \(Db2 Administration Guide\)](#)

[Conversion from index-controlled partitioning to Universal Table Space \(UTS\)](#)

Partitions

A *partition* is a page set that corresponds to a single data set that can be processed or extended independently.

Db2 usually distributes the data evenly across the partitions of a table space when it is created. However, the distribution of the data might become uneven over time, as inserts and deletes occur. You can rebalance data among the partitions by redefining partition boundaries with no impact to availability. You can also add a partition to the table and to each partitioned index on the table; the new partition becomes available immediately.

You can spread the partitions of a large table over several Db2 storage groups or data sets. The partitions of the table do not all need to use the same storage group.

You can also put different partitions on different device types, which means that you can put frequently accessed data in separate partitions and place these partitions on faster devices.

You can use separate jobs for mass update, delete, or insert operations instead of using one large job; each smaller job can work on a different partition. Separating the large job into several smaller jobs that run concurrently can reduce the elapsed time for the whole task.

For certain read-only queries, Db2 can use parallel processing on more than one partition. Parallel processing (for read-only queries) is most efficient when you spread the partitions over different disk volumes and allow each I/O stream to operate on a separate channel. Use the Parallel Sysplex data sharing technology to process a single read-only query across many Db2 subsystems in a data sharing group. You can optimize Parallel Sysplex query processing by placing each Db2 subsystem on a separate central processor complex.

Certain table space types do not have partitions, including segmented (non-UTS) table spaces and simple table spaces. However, all such table spaces are deprecated.

Growth-based partitions

Related concepts

[Partition-by-range table spaces \(Db2 Administration Guide\)](#)

[Partition-by-growth table spaces \(Db2 Administration Guide\)](#)

[Partitioned \(non-UTS\) table spaces \(deprecated\) \(Db2 Administration Guide\)](#)

Segments

A *segment* is a group of pages that holds the rows of a single table. All segments in a table space are the same size.

Related reference

[DEFAULT PARTITION SEGSIZE field \(DPSEGSZ subsystem parameter\) \(Db2 Installation and Migration\)](#)

Db2 index spaces

An *index space* is a Db2 storage structure that contains a single index.

When you create an index by using the CREATE INDEX statement, an index space is automatically defined in the same database as the table. You can define a unique name for the index space, or Db2 can derive a unique name for you. Under certain circumstances, Db2 implicitly creates index spaces.

Rules for primary and secondary space allocation

You can specify the primary and secondary space allocation or let Db2 choose them. Having Db2 choose the values, especially the secondary space quantity, increases the possibility of reaching the maximum data set size before running out of extents.

In the following rules that describe how allocation works, these terms are used:

PRIQTY, SECQTY

The keywords for CREATE TABLESPACE, ALTER TABLESPACE, CREATE INDEX, and ALTER INDEX.

specified-priqty

The user-specified value for PRIQTY.

specified-secqty

The user-specified value for SECQTY.

actual-priqty

The actual primary space allocation, in kilobytes.

actual-priqty-cylinders

The actual primary space allocation, in cylinders.

actual-secqty

The actual secondary space allocation, in kilobytes.

actual-secqty-cylinders

The actual secondary space allocation, in cylinders.

calculated-extent-cylinders

A value that is calculated by Db2 using a *sliding scale*. A sliding scale means that the first secondary extent allocations are smaller than later secondary allocations. For example, Figure 12 on page 52 shows the sliding scale of secondary extent allocations that Db2 uses for a 64-GB data set. The size of each secondary extent is larger for each secondary extent that is allocated up to the 127th extent. For the 127th secondary extent and any subsequent extents, the secondary size allocation is 559 cylinders.

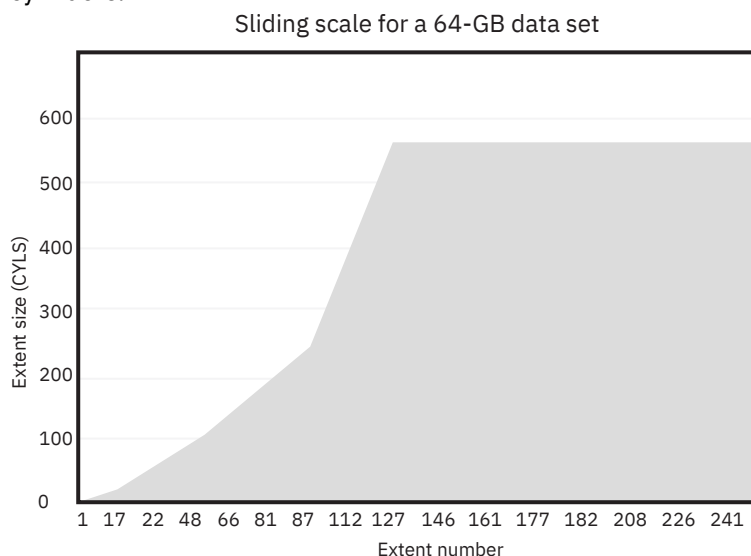

Figure 12. Sliding scale allocation of secondary extents for a 64 GB data set

Rules**Rule 1: (for primary space allocation)**

If PRIQTY is specified and *specified-priqty* is not equal to -1, *actual-priqty* is at least *specified-priqty* KB.

If PRIQTY is not specified or *specified-priqty* is equal to -1, *actual-priqty* is determined as follows:

- For a table space, if the TSQTY subsystem parameter value is specified and is greater than 0, *actual-priqty* is at least the value of TSQTY.

If the TSQTY subsystem parameter is not specified or is 0, *actual-priqty* is one cylinder for a non-LOB table space. *actual-priqty* is 10 cylinders for a LOB table space.

- For an index, if the IXQTY subsystem parameter value is specified and is greater than 0, *actual-priqty* is at least the value of IXQTY.

If the IXQTY subsystem parameter is not specified or is 0, *actual-priqty* is one cylinder.

Rule 2: (for secondary space allocation)

If SECQTY is not specified, the following formulas determine *actual-secqty*:

- If the maximum size of a data set in the table space or index is less than 32 GB, the formula is:

```
actual-secqty-cylinders=
MAX(0.1*actual-priqty-cylinders, MIN(calculated-extent-cylinders, 127))
```

- If the maximum size of a data set in the table space or index is 32 GB or greater, the formula is:

```
actual-secqty-cylinders=
MAX(0.1*actual-priqty-cylinders, MIN(calculated-extent-cylinders, 559))
```

Rule 3 (for secondary space allocation)

If SECQTY is 0, *actual-secqty* is 0.

Rule 4 (for secondary space allocation)

If SECQTY is specified and *specified-secqty* is not equal to -1 or 0, the following formulas determine *actual-secqty*. If the maximum size of a data set in the table space or index is less 32 GB, the formula is:

```
actual-secqty-cylinders=
MAX(MIN(calculated-extent-cylinders, 127),specified-secqty-cylinders)
```

If the maximum size of a data set in the table space or index is 32 GB or greater, the formula is:

```
actual-secqty-cylinders=
MAX(MIN(calculated-extent-cylinders, 559),specified-secqty-cylinders)
```

Rule 5 (for secondary space allocation):

When a table space requires a new piece, the primary allocation quantity of the new piece is determined by using the maximum of the following values:

- The quantity that is calculated through sliding scale methodology
- The primary quantity from rule 1
- The specified SECQTY value

Related referenceCREATE TABLESPACE statement

The CREATE TABLESPACE statement defines a table space at the current server. The type of table space depends on the keywords specified.

ALTER TABLESPACE statement

The ALTER TABLESPACE statement changes the description of a table space at the current server.

CREATE INDEX statement

The CREATE INDEX statement creates a partitioning index or a secondary index and an index space at the current server. The columns included in the key of the index are columns of a table at the current server.

ALTER INDEX statement

The ALTER INDEX statement changes the description of an index at the current server.

| Db2 hash spaces (deprecated)

A *hash space* is a defined disk space that organizes table data for hash access. Hash-organized table spaces are deprecated and likely to be unsupported in the future.

Deprecated function:

FL 504 Hash-organized tables are deprecated. Beginning in Db2 12, packages that are bound with APPLCOMPAT(V12R1M504) or higher cannot create hash-organized tables or alter existing tables to use hash-organization. Existing hash-organized tables remain supported, but they are likely to be unsupported in the future.

When you organize a table for hash access, Db2 requires a defined amount of disk space to contain table data. You can specify the amount of disk space to allocate to the hash space when you create a table or alter an existing table. The hash space on a table must be large enough to contain new rows that are added to the table. If a hash space is full, new rows are relocated to the overflow index, which reduces the performance of hash access on that table. Hash spaces can contain only a single table in a partition-by-range or partition-by-growth table space.

Related concepts

[Hash access paths \(deprecated\) \(Introduction to Db2 for z/OS\)](#)

Related tasks

[Managing space and page size for hash-organized tables \(deprecated\) \(Db2 Performance\)](#)

[Monitoring hash access \(deprecated\) \(Db2 Performance\)](#)

Db2 storage groups

Db2 *storage groups* are a set of volumes on disks that hold the data sets in which tables and indexes are stored.

The description of a storage group names the group and identifies its volumes and the VSAM (Virtual Storage Access Method) catalog that records the data sets. The default storage group, SYSDEFLT, is created when you install Db2.

Within the storage group, Db2 does the following actions:

- Allocates storage for table spaces and indexes
- Defines the necessary VSAM data sets
- Extends and deletes VSAM data sets
- Alters VSAM data sets

All volumes of a given storage group must have the same device type. However, parts of a single database can be stored in different storage groups.

Db2 can manage the auxiliary storage requirements of a database by using Db2 storage groups. Data sets in these Db2 storage groups are called "Db2-managed data sets."

These Db2 storage groups are not the same as storage groups that are defined by the DFSMS storage management subsystem (DFSMSsms).

You have several options for managing Db2 data sets:

- Let Db2 manage the data sets. This option means less work for Db2 database administrators.

After you define a Db2 storage group, Db2 stores information about it in the Db2 catalog. (This catalog is not the same as the integrated catalog facility catalog that describes Db2 VSAM data sets). The catalog table SYSIBM.SYSTOGRUP has a row for each storage group, and SYSIBM.SYSVOLUMES has a row for each volume. With the proper authorization, you can retrieve the catalog information about Db2 storage groups by using SQL statements.

When you create table spaces and indexes, you name the storage group from which space is to be allocated. You can also assign an entire database to a storage group. Try to assign frequently accessed objects (indexes, for example) to fast devices, and assign seldom-used tables to slower devices. This approach to choosing storage groups improves performance.

If you are authorized and do not take specific steps to manage your own storage, you can still define tables, indexes, table spaces, and databases. A default storage group, SYSDEFLT, is defined when Db2 is installed. Db2 uses SYSDEFLT to allocate the necessary auxiliary storage. Information about SYSDEFLT, as with any other storage group, is kept in the catalog tables SYSIBM.SYSTOGRUP and SYSIBM.SYSVOLUMES.

For both user-managed and Db2-managed data sets, you need at least one integrated catalog facility (ICF) catalog; this catalog can be either a user catalog or a master catalog. These catalogs are created with the ICF. You must identify the catalog of the ICF when you create a storage group or when you create a table space that does not use storage groups.

- Let SMS manage some or all the data sets, either when you use Db2 storage groups or when you use data sets that you have defined yourself. This option offers a reduced workload for Db2 database administrators and storage administrators. You can specify SMS classes when you create or alter a storage group.
- Define and manage your own data sets using VSAM Access Method Services. This option gives you the most control over the physical storage of tables and indexes.

Recommendation: Use Db2 storage groups and whenever you can, either specifically or by default. Also use SMS managed Db2 storage groups whenever you can.

Related tasks

[Choosing data page sizes for LOB data \(Db2 Performance\)](#)

Application processes, concurrency, and recovery

All SQL programs execute as part of an *application process*. An application process involves the execution of one or more programs, and it is the unit to which Db2 allocates resources and locks.

Different application processes might involve the execution of different programs, or different executions of the same program. The means of initiating and terminating an application process are dependent on the environment.

Locking, commit, and rollback

More than one application process might request access to the same data at the same time. Furthermore, under certain circumstances, an SQL statement can execute concurrently with a utility on the same table space. *Locking* is used to maintain data integrity under such conditions, preventing, for example, two application processes from updating the same row of data simultaneously.

Db2 implicitly acquires locks to prevent uncommitted changes made by one application process from being perceived by any other. Db2 will implicitly release all locks it has acquired on behalf of an application process when that process ends, but an application process can also explicitly request that locks be released sooner. A *commit* operation releases locks acquired by the application process and commits database changes made by the same process.

Db2 provides a way to *back out* uncommitted changes made by an application process. This might be necessary in the event of a failure on the part of an application process, or in a *deadlock* situation. An application process, however, can explicitly request that its database changes be backed out. This operation is called *rollback*.

The interface used by an SQL program to explicitly specify these commit and rollback operations depends on the environment. If the environment can include recoverable resources other than Db2 databases, the SQL COMMIT and ROLLBACK statements cannot be used. Thus, these statements cannot be used in an IMS, CICS, or WebSphere environment.

Unit of work

A *unit of work* is a recoverable sequence of operations within an application process. A unit of work is sometimes called a *logical unit of work*.

At any time, an application process has a single unit of work, but the life of an application process can involve many units of work as a result of commit or full rollback operations.

A unit of work is initiated when an application process is initiated. A unit of work is also initiated when the previous unit of work is ended by something other than the end of the application process. A unit of work is ended by a commit operation, a full rollback operation, or the end of an application process. A commit or rollback operation affects only the database changes made within the unit of work it ends. While these changes remain uncommitted, other application processes are unable to perceive them unless they are running with an isolation level of uncommitted read. The changes can still be backed out. Once committed, these database changes are accessible by other application processes and can no longer be backed out by a rollback. Locks acquired by Db2 on behalf of an application process that protects uncommitted data are held at least until the end of a unit of work.

The initiation and termination of a unit of work define *points of consistency* within an application process. A point of consistency is a claim by the application that the data is consistent. For example, a banking transaction might involve the transfer of funds from one account to another. Such a transaction would require that these funds be subtracted from the first account, and added to the second. Following the subtraction step, the data is inconsistent. Only after the funds have been added to the second account is consistency reestablished. When both steps are complete, the commit operation can be used to end the unit of work, thereby making the changes available to other application processes. The following figure illustrates this concept.

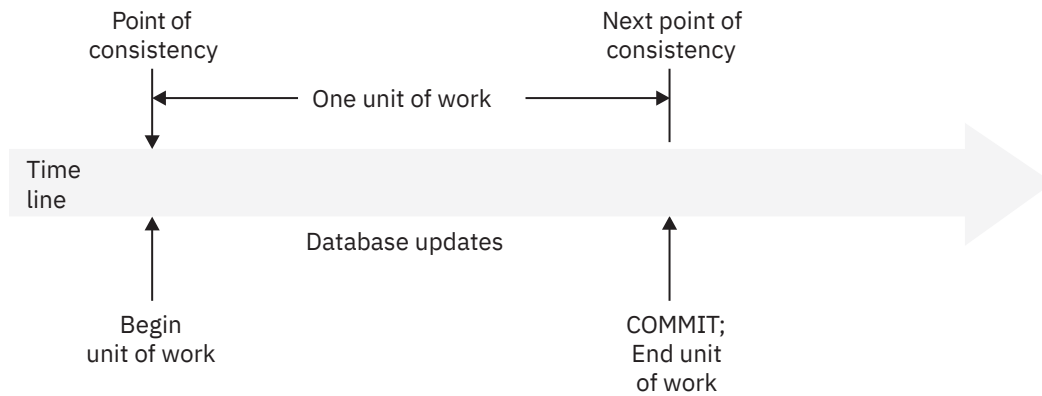

Figure 13. Unit of work with a commit operation

Unit of recovery

A Db2 unit of recovery is a recoverable sequence of operations executed by Db2 for an application process.

If a unit of work involves changes to other recoverable resources, the unit of work will be supported by other units of recovery. If relational databases are the only recoverable resources used by the application process, then the scope of the unit of work and the unit of recovery are the same and either term can be used.

Rolling back work

Db2 can back out all changes made in a unit of recovery or only selected changes. Only backing out all changes results in a point of consistency.

Rolling back all changes

The SQL ROLLBACK statement without the TO SAVEPOINT clause specified causes a full rollback operation. If such a rollback operation is successfully executed, Db2 backs out uncommitted changes to restore the data consistency that existed when the unit of work was initiated.

That is, Db2 undoes the work, as shown in the following figure:

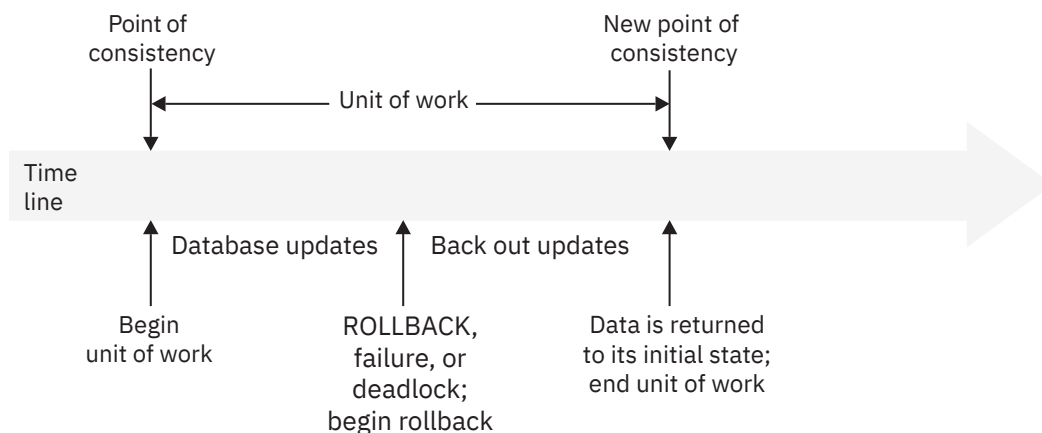

Figure 14. Rolling back all changes from a unit of work

Rolling back selected changes using savepoints

A *savepoint* represents the state of data at some particular time during a unit of work. An application process can set savepoints within a unit of work, and then as logic dictates, roll back only the changes that were made after a savepoint was set.

For example, part of a reservation transaction might involve booking an airline flight and then a hotel room. If a flight gets reserved but a hotel room cannot be reserved, the application process might want to undo the flight reservation without undoing any database changes made in the transaction prior to making the flight reservation. SQL programs can use the SQL SAVEPOINT statement to set savepoints, the SQL ROLLBACK statement with the TO SAVEPOINT clause to undo changes to a specific savepoint or the last savepoint that was set, and the SQL RELEASE SAVEPOINT statement to delete a savepoint. The following figure illustrates this concept.

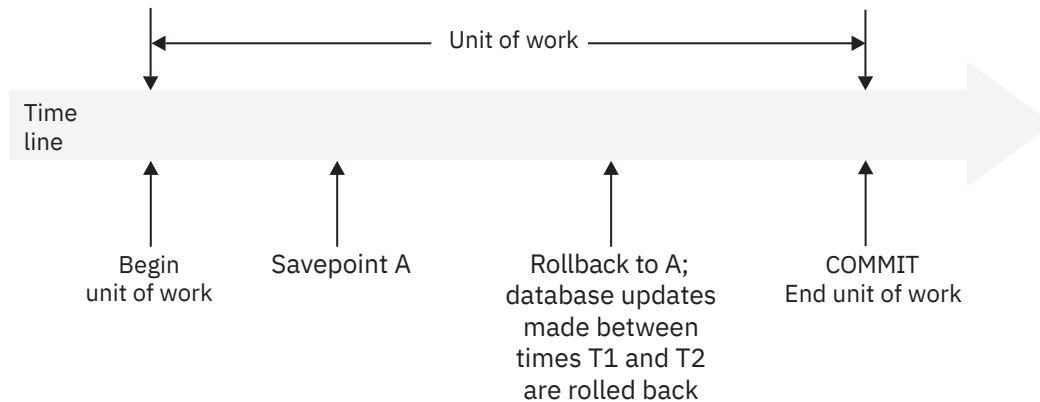

Figure 15. Rolling back changes to a savepoint within a unit of work

Packages and application plans

A *package* contains control structures that Db2 uses when it runs SQL statements. An *application plan* relates an application process to a local instance of Db2 and specifies processing options.

Packages are produced during program preparation. You can think of the control structures as the bound or operational form of SQL statements. All control structures in a package are derived from the SQL statements that are embedded in a single source program.

An application plan contains a list of package names.

Db2 applications require an application plan. Packages make application programs more flexible and easier to maintain.

In general, you create plans and packages by using the Db2 commands BIND PLAN and BIND PACKAGE.

Example

The following figure shows an application plan that contains two packages. Suppose that you decide to change the SELECT statement in package AA to select data from a different table. In this case, you need to bind only package AA again and not package AB.

GUI

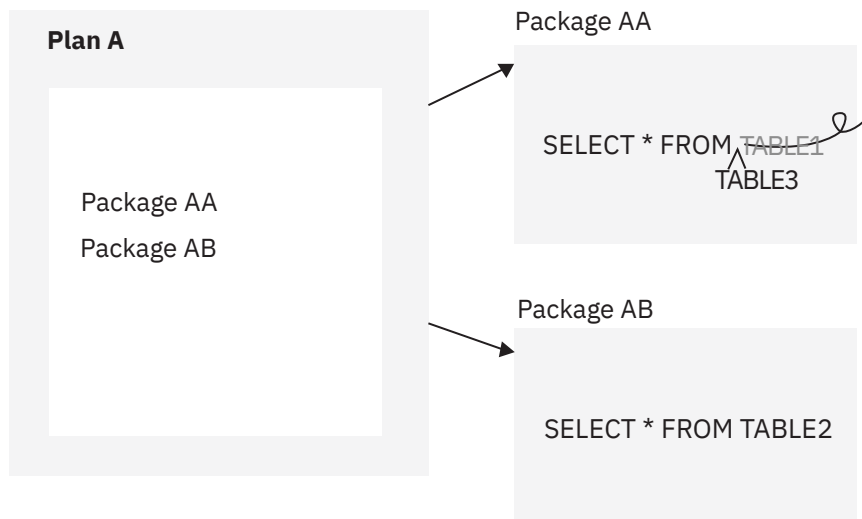

Figure 16. Application plan and packages

GUPI

Packages for triggers and routines

A *trigger package* is a special type of package that is created when you issue a CREATE TRIGGER statement. It contains the trigger body and the WHEN clause for the trigger. When the trigger activates, the package executes one or more times.

Packages are also generated, or explicitly created for certain SQL routines, including stored procedures and certain types of user defined functions. The package for a routine contains the routine body, including control statements. The package might also contain statements that are generated by Db2. Each time that the routine is invoked, the package executes one or more times.

Specifically, Db2 generates a package automatically for the following types of SQL routines:

- External scalar functions
- External table functions
- Compiled SQL scalar functions
- Native SQL procedures
- External SQL procedures

For external stored procedures, you explicitly bind the source code for the stored procedure into a package before or you issue the CREATE PROCEDURE statement. Each time that the external procedure is invoked, the package executes one or more times.

Packages for JDBC, SQLJ, and ODBC applications

Packages for JDBC, SQLJ, and ODBC applications serve different purposes. For more information, see [Preparing and running JDBC and SQLJ programs \(Db2 Application Programming for Java\)](#) and [Db2 ODBC run time environment setup \(Db2 Programming for ODBC\)](#).

Related concepts

[Programming for Db2 for z/OS \(Introduction to Db2 for z/OS\)](#)

[Preparation process for an application program \(Introduction to Db2 for z/OS\)](#)

Related reference

[SET CURRENT PACKAGE PATH statement](#)

The SET CURRENT PACKAGE PATH statement assigns a value to the CURRENT PACKAGE PATH special register.

[SET CURRENT PACKAGESET statement](#)

The SET CURRENT PACKAGESET statement assigns a value to the CURRENT PACKAGESET special register.

CREATE FUNCTION statement (overview)

The CREATE FUNCTION statement registers a user-defined function with a database server. Each type of function that you can register with this statement is described separately.

CREATE PROCEDURE statement (overview)

The CREATE PROCEDURE statement registers a stored procedure with a database server. You can register the following types of procedures with this statement, each of which is described separately.

CREATE TRIGGER statement (basic trigger)

Character conversion

A *string* is a sequence of bytes that can represent characters. Within a string, all the characters are represented by a common encoding representation. In some cases, it might be necessary to convert these characters to a different encoding representation. The process of conversion is known as *character conversion*.

Character conversion, when required, is automatic, and when successful, it is transparent to the application.

In client/server environments, character conversion can occur when an SQL statement is executed remotely. Consider, for example, the following two cases. In either case, the data could have a different representation at the sending and receiving systems.

- The values of data sent from the requester to the current server
- The values of data sent from the current server to the requester

Conversion can also occur during string operations on the same system, as in the following examples:

- An overriding CCSID is specified.

For example, an SQL statement with a descriptor, which requires an SQLDA. In the SQLDA, the CCSID is in the SQLNAME field for languages other than REXX, and in the SQLCCSID field for REXX. (For more information, see Appendix G, “SQL descriptor area (SQLDA),” on page 2313). A DECLARE VARIABLE statement can also be issued to associate a CCSID with the host variables into which data is retrieved from a table.

- The value of the ENCODING bind option or the APPLICATION ENCODING SCHEMA option of the CREATE PROCEDURE or ALTER PROCEDURE statement for a native SQL procedure (static SQL statements) or the CURRENT APPLICATION ENCODING SCHEMA special register (for dynamic SQL) is different than encoding scheme of the data being retrieved.
- A mixed character string is assigned to an SBCS column or host variable.
- An SQL statement refers to data that is defined with different CCSIDs.

The text of an SQL statement is also subject to character conversion because it is a character string.

The following list defines some of the terms used for character conversion.

ASCII

Acronym for American Standard Code for Information Interchange, an encoding scheme used to represent characters. The term ASCII is used throughout this information to refer to IBM-PC Data or ISO 8-bit data.

character set

A defined set of characters, a character being the smallest component of written language that has semantic value. For example, the following character set appears in several code pages:

- 26 nonaccented letters A through Z
- 26 nonaccented letters a through z
- digits 0 through 9
- . , ; ? () ' " / - _ & + % * = < >

code page

A set of assignments of characters to code points. For example, in EBCDIC, "A" is assigned code point X'C1', and "B" is assigned code point X'C2'. In Unicode UTF-8, "A" is assigned code point X'41', and "B" is assigned code point X'42'. Within a code page, each code point has only one specific meaning.

code point

A unique bit pattern that represents a character. It is a numerical index or position in an encoding table used for encoding characters.

coded character set

A set of unambiguous rules that establishes a character set and the one-to-one relationships between the characters of the set and their coded representations. It is the assignment of each character in a character set to a unique numeric code value.

coded character set identifier (CCSID)

A two-byte, unsigned binary integer that uniquely identifies an encoding scheme and one or more pairs of character sets and code pages.

EBCDIC

Acronym for Extended Binary-Coded Decimal Interchange Code, an encoding scheme used to represent character data, a group of coded character sets that consist of 8 bit coded characters. EBCDIC coded character sets use the first 64 code positions (X'00' to X'3F') for control codes. The range X'41' to X'FE' is used for single-byte characters. For double-byte characters, the first byte is in the range X'41' to X'FE' and the second byte is also in the range X'41' to X'FE', while X'4040' represents a double-byte space.

encoding scheme

A set of rules used to represent character data. All string data stored in a table must use the same encoding scheme and all tables within a table space must use the same encoding scheme, except for global temporary tables, declared temporary tables, and work file table spaces. Db2 supports these encoding schemes:

- ASCII
- EBCDIC
- Unicode

substitution character

A unique character that is substituted during character conversion for any characters in the source encoding representation that do not have a match in the target encoding representation.

Unicode

A universal encoding scheme for written characters and text that enables the exchange of data internationally. It provides a character set standard that can be used all over the world. It provides the ability to encode all characters used for the written languages of the world and treats alphabetic characters, ideographic characters, and symbols equivalently because it specifies a numeric value and a name for each of its characters. It includes punctuation marks, mathematical symbols, technical symbols, geometric shapes, and dingbats. Db2 supports these two encoding forms:

- UTF-8: Unicode Transformation Format, a 8 bit encoding form designed for ease of use with existing ASCII-based systems. UTF-8 can encode any of the Unicode characters. A UTF-8 character is 1,2,3, or 4 bytes in length. A UTF-8 data string can contain any combination of SBCS and MBCS data, including supplementary characters. The CCSID value for data in UTF-8 format is 1208. UTF-8 has multiple code points for spaces, including the '20'X single-byte space that Db2 uses for padding UTF-8 data.
- UTF-16: Unicode Transformation Format, a 16 bit encoding form designed to provide code values for over a million characters and a superset of UCS-2. UTF-16 can encode any of the Unicode characters. In UTF-16 encoding, characters are 2 bytes in length, except for supplementary characters, which take two 2 byte string units per character. The CCSID value for data in UTF-16 format is 1200. UTF-16 has multiple code points for spaces, including the '0020'X single-byte space that Db2 uses for padding UTF-16 data.

Character data (CHAR, VARCHAR, and CLOB) is encoded in Unicode UTF-8. Character strings are also used for mixed data (that is a mixture of single-byte characters and multi-byte characters)

and for data that is not associated with any character set (called bit data). Graphic data (GRAPHIC, VARGRAPHIC, and DBCLOB) is encoded in Unicode UTF-16. For a comparison of some UTF-8 and UTF-16 code points for some sample characters, see [Character sets and code pages \(Introduction to Db2 for z/OS\)](#). This table shows how a UTF-8 character can be 1 to 4 bytes in length, a non-supplementary UTF-16 character is 2 bytes in length, and how a supplementary character in either UTF-8 or UTF-16 takes two 2 byte code points.

Character conversion can affect the results of several SQL operations. In this information, the effects are described in:

[“String assignments” on page 149](#)

[“Conversion rules for comparisons” on page 159](#)

[“Character conversion in set operations and concatenations” on page 1066](#)

Character sets and code pages

Even with the same encoding scheme, different CCSIDs exist, and the same code point can represent a different character in different CCSIDs. Furthermore, a byte in a character string does not necessarily represent a character from a single-byte character set (SBCS).

The following figure shows how a typical character set might map to different code points in two different code pages.

Code page: pp1 (ASCII)

	0	1	2	3	4	5		E	F
0			0	@	P			Â	
1			1	A	Q			À	α
2			†	2	B	R		Å	β
3				3	C	S		Á	γ
4				4	D	T		Ä	σ
5			%	5	E	U		Ä	ε
E			.	>	N			¼	ö
F			/	*	O			®	

Code point: 2F

Character set ss1
(in code page pp2)

Code page: pp2 (EBDIC)

	0	1		A	B	C	D	E	F
0					#				0
1					\$	A	J		1
2				s	%	B	K	S	2
3				t	¬	C	L	T	3
4				u	*	D	M	U	4
5				v	(E	N	V	5
E					!	:	Â	}	
F				À	□	;	Á	{	

Character set ss1
(in code page pp1)

Figure 17. Code page mappings for character set ss1 in ASCII and EBCDIC

For Unicode, there is only one CCSID for UTF-8 and only one CCSID for UTF-16. The following figure shows how the first 127 single code points for UTF-8 are the same as ASCII with a CCSID of 367. For example, in both UTF-8 and ASCII CCSID 367, an A is X'41' and a 1 is X'31'.

First 127 code points for UTF-8 code page

	0	1	2	3	4	5	6	7
0			(sp)	0	@	P	`	p
1			!	1	A	Q	a	q
2			"	2	B	R	b	r
3			#	3	C	S	c	s
4			\$	4	D	T	d	t
5			%	5	E	U	e	u
6			&	6	F	V	f	v
7			'	7	G	W	g	w
8			(8	H	X	h	x
9)	9	I	Y	i	y
A			*	:	J	Z	j	z
B			+	;	K	[k	{
C			,	<	L	\	l	
D			-	=	M]	m	}
E			.	>	N	^	n	~
F			/	?	O	_	o	

code point:2f

Figure 18. Code point mapping for the first 127 code points for UTF-8 single-byte characters (CCSID 1208)

The following figure shows a comparison of how some UTF-16 and UTF-8 code points map to some sample characters. The character for the eighth note musical symbol takes two 2 byte code points because it is a supplementary character.

Character glyph	UTF-8 code point	UTF-16 code point
M	4D	004D
Ä	C384	00C4
事	E4BA8B	4E8B
♪	F09D85A0	D834DD60

Figure 19. A comparison of how some UTF-8 and UTF-16 code points map to some sample characters

Related concepts

[Introduction to character conversion \(Db2 Internationalization Guide\)](#)

Related information

[Unicode Consortium](#)

Coded character sets and CCSIDS

The IBM *character data representation architecture (CDRA)* deals with the differences in string representation and encoding. The *Coded Character Set Identifier (CCSID)* is a key element of this architecture. A CCSID is a 2 byte (unsigned) binary number that uniquely identifies an encoding scheme and one or more pairs of character sets and code pages.

A CCSID is an attribute of strings, just as length is an attribute of strings. All values of the same string column have the same CCSID.

Character conversion is described in terms of CCSIDs of the source and target. With Db2 for z/OS, two methods are used to identify valid source and target combinations and to perform the conversion from one coded character set to another:

- Db2 catalog table SYSIBM.SYSSTRINGS

Each row in the catalog table describes a conversion from one coded character set to another.

- z/OS support for Unicode.

In some cases, no conversion is necessary even though the strings involved have different CCSIDs.

Different types of conversions might be supported by each database manager. Round-trip conversions attempt to preserve characters in one CCSID that are not defined in the target CCSID so that if the data is subsequently converted back to the original CCSID, the same original characters result. Enforced subset match conversions do not attempt to preserve such characters. Which type of conversion is used for a specific source and target CCSID is product-specific.

Related concepts

[Introduction to character conversion \(Db2 Internationalization Guide\)](#)

[z/OS Unicode Services User's Guide and Reference](#)

Related tasks

[Working with international data \(Db2 Installation and Migration\)](#)

Related reference

[SYSSTRINGS catalog table](#)

The SYSSTRINGS table contains information about character conversion. Each row describes a conversion from one coded character set to another. The schema is SYSIBM.

Determining the encoding scheme and CCSID of a string

An encoding scheme and a CCSID are attributes of strings, just as length is an attribute of strings. All values of the same string column have the same encoding scheme and CCSID.

Every string has an encoding scheme and a CCSID that identifies the manner in which the characters in the string are encoded. Strings can be encoded in ASCII, EBCDIC, or Unicode.

The CCSID that is associated with a string value depends on the SQL statement in which the data is referenced and the type of expression. Use the Type 1 rules when the SQL statement meets the following conditions:

- The SQL statement operates with a single set of CCSIDs (SBCS, mixed, and graphic). An SQL statement that does not contain any of the following items operates with a single set of CCSIDs:
 - References to columns from multiple tables or views that are defined with CCSIDs from more than one set of CCSIDs (SBCS, mixed, and graphic)
 - References to an EBCDIC table that contains a Unicode column
 - Graphic hexadecimal (GX) or hexadecimal Unicode (UX) string constants
 - References to the XMLCLOB built-in function
 - Cast specifications with a CCSID clause
 - User-defined table functions
- The SQL statement is not one of the following statements:
 - CALL statement
 - SET assignment statement
 - SET special register
 - VALUES statement
 - VALUES INTO statement
- One of the following built-in functions is not referenced:
 - ASCII_CHR
 - ASCII_STR (or ASCIISTR)
 - CHR
 - DECRYPT_BIT

- DECRYPT_CHAR
- DECRYPT_DATAKEY_BIT
- DECRYPT_DATAKEY_CLOB
- DECRYPT_DATAKEY_DBCLOB
- DECRYPT_DATAKEY_VARCHAR
- DECRYPT_DATAKEY_VARGRAPHIC
- DECRYPT_DB
- EBCDIC_CHR
- EBCDIC_STR
- GETVARIABLE
- JSON_VAL
- NORMALIZE_STRING
- UNICODE_STR (or UNISTR)
- XMLSERIALIZE

- The SQL statement does not include a collection-derived table (UNNEST).

Use the Type 2 rules when the statement does not meet the conditions for Type 1 rules.

For those SQL statements and tools that use a SYSDUMMYx table, use the SYSDUMMYx table that has the same encoding scheme as the other objects in your SQL statement, to avoid conversions. A SYSDUMMYx table is available in each encoding scheme. For example, suppose that your SQL statement references a SYSDUMMYx table that is in a different encoding scheme from other objects in the statement. Db2 treats this statement as one that references objects with different CCSIDs (Type 2 rules), and conversion is likely to occur. To avoid this situation, reference the SYSDUMMYx table that has the same encoding scheme as the other objects in your SQL statement. See [SYSDUMMYx tables \(Introduction to Db2 for z/OS\)](#) for more information.

Table 10 on page 64 describes the rules for determining the CCSID of derived string data when the source data has a string type.

Table 10. Rules for determining the CCSID that is associated with string data derived from string data

Source of the string data	Type 1 rules	Type 2 rules
String constant	<p>If the statement references a table or view, the encoding scheme of that table or view determines the encoding scheme for the string constant.</p> <p>The CCSID is the appropriate character string CCSID of the encoding scheme.</p>	<p>The CCSID is the appropriate character string CCSID of the application encoding scheme. “1” on page 66</p>
Datetime constant	<p>If the statement references a table or view, the encoding scheme of that table or view determines the encoding scheme for the string constant.</p> <p>Otherwise, the default EBCDIC encoding scheme is used for the string constant.</p> <p>The CCSID is the appropriate character string CCSID of the encoding scheme.</p>	<p>The CCSID is the appropriate character string CCSID of the application encoding scheme. “1” on page 66</p>

Table 10. Rules for determining the CCSID that is associated with string data derived from string data (continued)

Source of the string data	Type 1 rules	Type 2 rules
Hexadecimal string constant (X'...')	<p>If the statement references a table or view, the encoding scheme of that table or view determines the encoding scheme for the string constant.</p> <p>Otherwise, the default EBCDIC encoding scheme is used for the string constant.</p> <p>The CCSID is the appropriate graphic string CCSID of the encoding scheme.</p>	<p>The CCSID is the appropriate character string CCSID of the application encoding scheme. ^{"1"} on page 66</p>
Graphic string constant (G'...')	<p>If the statement references a table or view, the encoding scheme of that table or view determines the encoding scheme for the graphic string constant.</p> <p>Otherwise, the default EBCDIC encoding scheme is used for the graphic string constant.</p> <p>The CCSID is the graphic string CCSID of the encoding scheme.</p>	<p>The CCSID is the graphic string CCSID of the application encoding scheme. ^{"1"} on page 66</p>
Graphic hexadecimal constant (GX'...')	Not applicable.	The CCSID is the graphic string CCSID of the application encoding scheme, which must be ASCII or EBCDIC.
Hexadecimal Unicode string constant (UX'....')	Not applicable.	The CCSID is 1200 (UTF-16).
Special register	<p>If the statement references a table or view, the encoding scheme of that table or view determines the encoding scheme for the special register.</p> <p>Otherwise, the default EBCDIC encoding scheme is used for the special register.</p> <p>The CCSID is the appropriate character string CCSID of the encoding scheme.</p>	<p>The CCSID is the appropriate CCSID of the application encoding scheme. ^{"1"} on page 66</p>
Column of a table	The CCSID is the CCSID that is associated with the column of the table.	The CCSID is the CCSID that is associated with the column of the table.
Column of a view	The CCSID is the CCSID of the column of the result table of the fullselect of the view definition.	The CCSID is the CCSID of the column of the result table of the fullselect of the view definition.
Expression	The CCSID is the CCSID of the result of the expression.	The CCSID is the CCSID of the result of the expression.

Table 10. Rules for determining the CCSID that is associated with string data derived from string data (continued)

Source of the string data	Type 1 rules	Type 2 rules
Result of a built-in function	<p>If the description of the function, in Chapter 4, “Built-in functions,” on page 341, indicates what the CCSID of the result is, the CCSID is that CCSID.</p> <p>Otherwise, if the description of the function refers to this table for the CCSID, the CCSID is the appropriate CCSID of the CCSID set that is used by the statement for the data type of the result.</p>	<p>If the description of the function, in Chapter 4, “Built-in functions,” on page 341, indicates what the CCSID of the result is, the CCSID is that CCSID.</p> <p>Otherwise, if the description of the function refers to this table for the CCSID, the CCSID is the appropriate CCSID of the application encoding scheme for the data type of the result. “1” on page 66</p>
Parameter of a user-defined routine	The CCSID is the CCSID that was determined when the function or procedure was created.	The CCSID is the CCSID that was determined when the function or procedure was created.
The expression in the RETURN statement of a CREATE statement for a user-defined SQL scalar function	If the expression in the RETURN statement is string data, the encoding scheme is the same as for the parameters of the function. The CCSID is determined from the encoding scheme and the attributes of the data.	The CCSID is determined from the CCSID of the result of the expression specified in the RETURN statement.
String host variable	<p>If the statement references a table or view, the encoding scheme of that table or view determines the encoding scheme for the host variable.</p> <p>Graphic variables are an exception if the table or view is EBCDIC or ASCII and the value of the MIXED DATA field on the DSNTIPF panel is NO. In this case, the Unicode encoding scheme is used for the graphic host variable.</p> <p>Otherwise, the default EBCDIC encoding scheme is used for the host variable.</p> <p>The CCSID is the appropriate CCSID of the data type of the host variable.</p>	<p>At package prepare time, the CCSID is the appropriate CCSID of the data type of the host variable for the application encoding scheme.</p> <p>Graphic variables are an exception if the application or encoding scheme is EBCDIC or ASCII and the value of the MIXED DATA field on the DSNTIPF panel is NO. In this case, the Unicode encoding scheme is used for the graphic host variable.</p> <p>At run time, the CCSID specified in the declare variable statement, or as an override in the SQLDA. Otherwise, the CCSID is the appropriate CCSID of the application encoding scheme for the data type of the host variable.</p>

Notes:

1. If the context is within a check constraint or a package for a basic trigger, the CCSID is the appropriate CCSID for Unicode, instead of the application encoding scheme. If the context is within a package for an advanced trigger, the CCSID is determined from the implicitly or explicitly specified APPLICATION ENCODING SCHEME option; otherwise the CCSID is the appropriate CCSID for Unicode instead of the application encoding scheme.

“Determining the encoding scheme and CCSID of a string” on page 63 shows the rules for determining the CCSID of derived string data when the source data has a numeric type.

Table 11. Rules for determining the CCSID that is associated with string data derived from numeric data

Source of the numeric data	Type 1 rules	Type 2 rules
Numeric data	<p>If the statement references a table or view, the encoding scheme of that table or view determines the encoding scheme for the string data that is derived from a numeric value.</p> <p>Otherwise, the default EBCDIC encoding scheme is used for the string data derived from a numeric value.</p> <p>The CCSID is the appropriate character or graphic string CCSID of the application encoding scheme.</p>	<p>The CCSID is the appropriate character or graphic string CCSID of the application encoding scheme. “1” on page 67</p>

Notes:

1. If the context is within a check constraint or a package for a basic trigger, the CCSID is the appropriate CCSID for Unicode, instead of the application encoding scheme. If the context is within a package for an advanced trigger, the CCSID is determined from the implicitly or explicitly specified APPLICATION ENCODING SCHEME option; otherwise the CCSID is the appropriate CCSID for Unicode instead of the application encoding scheme.

The following examples show how these rules are applied.

Example 1: Assume that the default encoding scheme for the installation is EBCDIC and that the installation does not support mixed and graphic data. The following statement conforms to the rules for Type 1 in [Table 10 on page 64](#). Therefore, the X'40' is interpreted as EBCDIC SBCS data because the statement references a table that is in EBCDIC. The CCSID for X'40' is the default EBCDIC SBCS CCSID for the installation.

```
SELECT * FROM EBCDIC_TABLE WHERE COL1 = X'40';
```

the result of the query includes each row that has a value in column COL1 that is equal to a single EBCDIC blank.

Example 2: The following statement references data from two different tables that use different encoding schemes. This statement does not conform to the rules for Type 1 statements in [Table 10 on page 64](#). Therefore, the rules for Type 2 statements are used. The CCSID for X'40' is dependent on the current application encoding scheme. Assuming that the current application encoding scheme is EBCDIC, X'40' represents a single EBCDIC blank.

```
SELECT * FROM EBCDIC_TABLE, UNICODE_TABLE WHERE COL1 = X'40';
```

as with Example 1, the result of the query includes each row that has a value in column COL1 that is equal to a single EBCDIC blank. If the current application encoding scheme were ASCII or Unicode, X'40' would represent something different and the results of the query would be different.

Expanding conversions

An *expanding conversion* occurs when the length of the converted string is greater than that of the source string.

For example, an expanding conversion occurs when an ASCII mixed data string that contains DBCS characters is converted to EBCDIC mixed data. To prevent the loss of data on expanding conversions, use a varying-length string variable with a maximum length that is sufficient to contain the expansion.

Expanding conversions also can occur when string data is converted to or from Unicode. It can also occur between UTF-8 and UTF-16, depending on the data being converted. UTF-8 uses 1, 2, 3, or 4 bytes per character. UTF-16 uses 2 bytes per character, except for supplementary characters, which use two 2 byte code points for each character. If UTF-8 were being converted to UTF-16, a 1 byte character would be expanded to 2 bytes.

Contracting conversions

A *contracting conversion* occurs when the length of the converted string is smaller than that of the source string.

For example, a contracting conversion occurs when an EBCDIC mixed data string that contains DBCS characters is converted to ASCII mixed data due to the removal of shift codes.

Contracting conversions also can occur when string data is converted to or from Unicode data. It can also occur between UTF-8 and UTF-16, depending on the data being converted.

Distributed relational databases

The database managers in a distributed relational database communicate and cooperate with each other in a way that allows a Db2 application program to use SQL to access data at any of the interconnected computer systems.

A *distributed relational database* consists of a set of tables and other objects that are spread across different, but interconnected, computer systems. Each computer system has a relational database manager, such as Db2, that manages the tables in its environment. The database managers communicate and cooperate with each other in a way that allows a Db2 application program to use SQL to access data at any of the computer systems. The Db2 subsystem where the application plan is bound is known as the *local Db2 subsystem*. Any database server other than the local Db2 subsystem is considered a *remote database server*, and access to its data is a distributed operation.

Distributed relational databases are built on formal requester-server protocols and functions. An *application requester* component supports the application end of a connection. It transforms an application's database request into communication protocols that are suitable for use in the distributed database network. These requests are received and processed by an *application server* component at the database server end of the connection. Working together, the application requester and application server handle the communication and location considerations so that the application is isolated from these considerations and can operate as if it were accessing a local database.

For more information on Distributed Relational Database Architecture™ (DRDA) communication protocols, see [DRDA Volume 1: Distributed Relational Database Architecture \(Open Group Library - Data Management Standards\)](#).

Related concepts

[Distributed data access \(Introduction to Db2 for z/OS\)](#)

Related tasks

[Improving performance for applications that access distributed data \(Db2 Performance\)](#)

Connections

A *connection* is an association between an application process and a local or remote database server. Connections are managed by applications.

An application process must be connected to the application server facility of a database manager before SQL statements that reference tables or views can be executed. An application can use the CONNECT statement to establish a connection to a database server and make that database server the current server of the application process.

Commit processing

When Db2 for z/OS acts as a requester, it negotiates with the database server during the connection process to determine how to perform commits. If the remote server does not support two-phase commit protocol, Db2 downgrades to perform one-phase commits. Otherwise, Db2 always performs two-phase commits, which allow applications to update one or more databases in a single unit of work and are more reliable than one-phase commits. Two-phase commit is a two-step process:

1. First, all database managers involved in the same unit of work are pooled to determine whether they are ready to commit.
2. Then, if all database managers respond positively, they are directed to execute commit processing. If all database managers do not respond positively, they are directed to execute backout processing.

Db2 can also provide coordination for transactions that include both two-phase commit resources and one-phase commit resources. If an application has multiple connections to several different database servers, and if any of the connections are one-phase commit connections, then only one database that is involved in the transaction can be updated. The connections to all the other databases that are involved in the transaction are read-only.

To execute a static SQL statement that references tables or views, the bound form of the statement is taken from a package that the database manager previously created through a bind operation or when a version of a native SQL procedure was defined.

Supported SQL statements and clauses

For the most part, an application can use the statements and clauses that are supported by the database manager of the current server, even though that application might be running via the application requester of a database manager that does not support some of those statements and clauses. Restrictions to this general rule for Db2 for z/OS are documented in [PDF SQL Reference for Cross-Platform Development - Version 6](#).

Distributed unit of work

The *distributed unit of work facility* provides for the remote preparation and execution of SQL statements.

An application process at computer system A can connect to a database server at computer system B and, within one or more units of work, execute any number of static or dynamic SQL statements that reference objects at B. All objects referenced in a single SQL statement must be managed by the same database server. Any number of database servers can participate in the same unit of work, and any number of connections can exist between an application process and a database server. A commit or rollback operation that does not specify a savepoint ends the unit of work.

Connection management

How connections are managed depends on what states the SQL connection and the application process are in.

At any time:

- An SQL connection is in one of the following states:
 - Current and held
 - Current and release-pending
 - Dormant and held
 - Dormant and release-pending
- An application process is in the connected or unconnected state, and has a set of zero or more SQL connections. Each SQL connection is uniquely identified by the name of the database server at the other end of the connection. Only one SQL connection is active (current) at a time.

Initial state of an application process: An application process is initially in the connected state, and it has exactly one SQL connection. The server of that connection is the local Db2 subsystem.

Initial state of an SQL connection: An SQL connection is initially in the current and held state.

The following figure shows the state transitions:

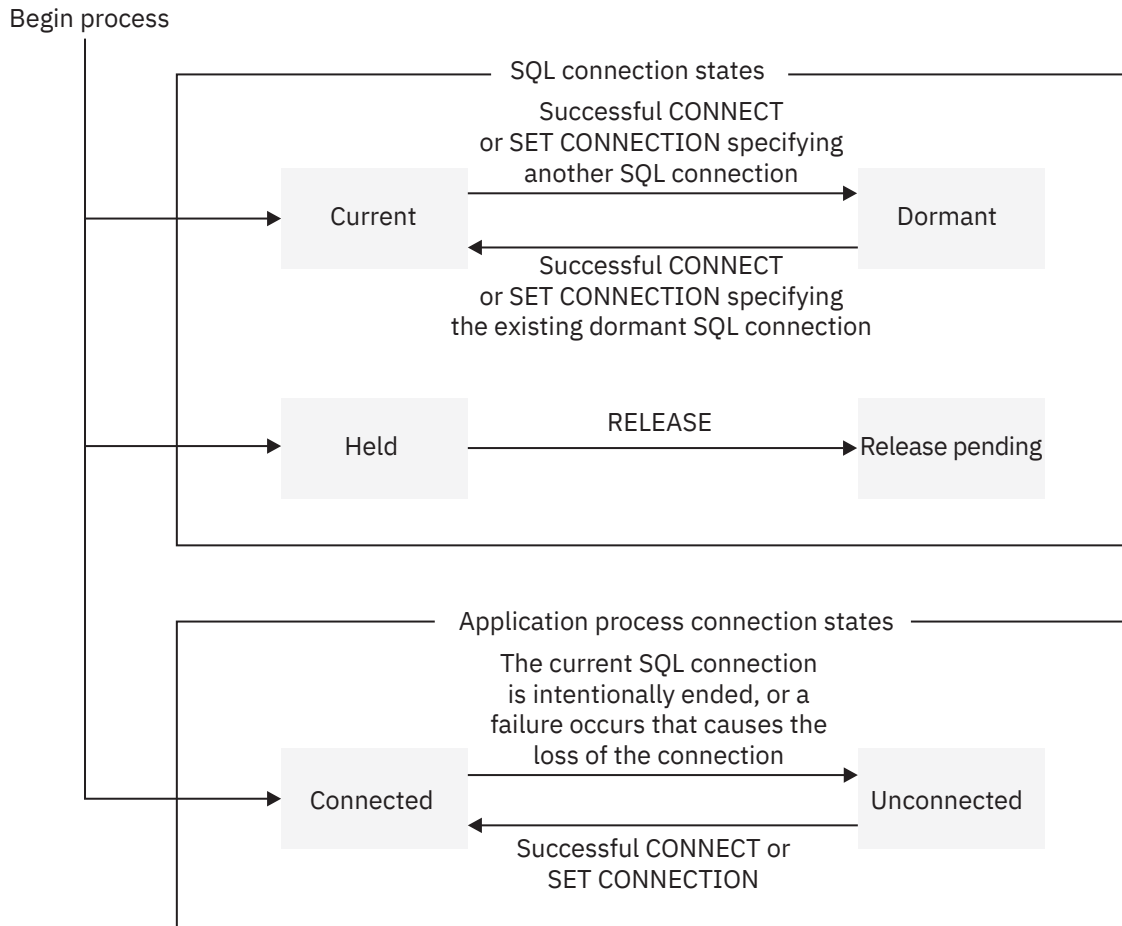

Figure 20. State transitions for an SQL connection and an application process connection in a distributed unit of work

SQL connection states

If an application process successfully executes a CONNECT statement, the SQL connection states of the connections change.

If an application process successfully executes a CONNECT statement:

- The current connection is placed in the dormant and held state.
- The new connection is placed in the current and held state.
- The location name is added to the set of existing connections.

If the location name is already in the set of existing connections, an error is returned.

An SQL connection in the dormant state is placed in the current state using:

- The SET CONNECTION statement, or
- The CONNECT statement, if the SQLRULES(DB2) bind option is in effect.

When an SQL connection is placed in the current state, the previously-current SQL connection, if any, is placed in the dormant state. No more than one SQL connection in the set of existing connections of an application process can be current at any time. Changing the state of an SQL connection from current to dormant or from dormant to current has no effect on its held or release-pending state.

An SQL connection is placed in the release-pending state by the RELEASE statement. When an application process executes a commit operation, every release-pending connection of the process is ended. Changing the state of an SQL connection from held to release-pending has no effect on its current or dormant state. Thus, an SQL connection in the release-pending state can still be used until the next commit operation. No way exists to change the state of a connection from release-pending to held.

Application process connection states

In a distributed unit of work, an application process can be in a connected or unconnected state. Depending on the state, the application process can execute only certain SQL statements successfully.

A connection to a different database server can be established by the explicit or implicit execution of a CONNECT statement. The following rules apply:

- An application process cannot have more than one SQL connection to the same database server at the same time.
- When an application process executes a SET CONNECTION statement, the specified location name must be in the set of existing connections of the application process.
- When an application process executes a CONNECT statement and the SQLRULES(STD) bind option is in effect, the specified location must not be in the set of existing connections of the application process.

If an application process has a current SQL connection, the application process is in a *connected* state. The CURRENT SERVER special register contains the name of the database server of the current SQL connection. The application process can execute SQL statements that refer to objects managed by that server. If the server is a Db2 subsystem, the application process can also execute certain SQL statements that refer to objects managed by a Db2 subsystem with which that server can establish a connection.

An application process in an unconnected state enters a connected state when it successfully executes a CONNECT or SET CONNECTION statement.

If an application process does not have a current SQL connection, the application process is in an *unconnected* state. The CURRENT SERVER special register contains blanks. The only SQL statements that can be executed successfully are CONNECT, RELEASE, COMMIT, ROLLBACK, and any of the following local SET statements.

- SET CONNECTION
- SET CURRENT APPLICATION ENCODING SCHEME
- SET CURRENT PACKAGE PATH
- SET CURRENT PACKAGESET
- SET *host-variable* = CURRENT APPLICATION ENCODING SCHEME
- SET *host-variable* = CURRENT PACKAGESET
- SET *host-variable* = CURRENT SERVER

Because the application process is in an unconnected state, a COMMIT or ROLLBACK statement is processed by the local Db2 subsystem.

An application process in a connected state enters an unconnected state when its current SQL connection is intentionally ended, or the execution of an SQL statement is unsuccessful because of a failure that causes a rollback operation at the current server and loss of the SQL connection. SQL connections are intentionally ended when an application process successfully executes a commit operation and either of the following are true:

- The SQL connection is in the release-pending state.
- The SQL connection is not in the release-pending state, but it is a remote connection and either of the following are true:
 - The DISCONNECT(AUTOMATIC) bind option is in effect
 - The DISCONNECT(CONDITIONAL) bind option is in effect and an open WITH HOLD cursor is not associated with the connection

An implicit CONNECT to a default Db2 subsystem is executed when an application process executes an SQL statement other than COMMIT, CONNECT TO, CONNECT RESET, SET CONNECTION, RELEASE, or ROLLBACK, and if all of the following conditions apply:

- The CURRENTSERVER bind option was specified when creating the application plan of the application process and the identified server is not the local Db2.
- An explicit CONNECT statement has not already been successfully or unsuccessfully executed by the application process.
- An implicit connection has not already been successfully or unsuccessfully executed by the application process. An implicit connection occurs as the result of execution of an SQL statement that contains a three-part name in a package that is bound with the DBPROTOCOL(DRDA) option.

If the implicit CONNECT fails, the application process is placed in an *unconnected* state.

When a connection is ended, all resources that were acquired by the application process through the connection and all resources that were used to create and maintain the connection are returned to the connection pool. For example, if application process *P* placed the connection to application server *X* in the release-pending state, all cursors of *P* at *X* are closed and returned to the connection pool when the connection is ended during the next commit operation.

When a connection is ended as a result of a communications failure, the application process is placed in an unconnected state.

All connections of an application process are ended when the process ends.

Remote unit of work

The *remote unit of work facility* also provides for the remote preparation and execution of SQL statements, but in a much more restricted fashion than the distributed unit of work facility.

An application process at computer system A can connect to a database server at computer system B and, within one or more units of work, execute any number of static or dynamic SQL statements that reference objects at B. All objects referenced in a single SQL statement must be managed by the same database server, and all SQL statements in the same unit of work must be executed by the same database server. However, unlike a distributed unit of work, an application process can have only one connection at a time. The process cannot connect to a new server until it executes a commit or rollback operation on the current server to end that unit of work. This restricts the situations in which a CONNECT statement can be executed.

Connection management

How connections are managed depends on what states the SQL connection and the application process are in.

An application process is in one of four states at any time:

- Connectable and connected
- Unconnectable and connected
- Connectable and unconnected
- Unconnectable and unconnected

Initial state of an application process: An application process is initially in the connectable and connected state. The database server to which the application process is connected is determined by a product-specific option that might involve an implicit CONNECT operation. An implicit connect operation cannot occur if an implicit or explicit connect operation has already successfully or unsuccessfully occurred. Thus, an application process cannot be implicitly connected to a database server more than once. Other rules for implicit connect operations are product-specific.

Figure 21 on page 73 shows the state transitions:

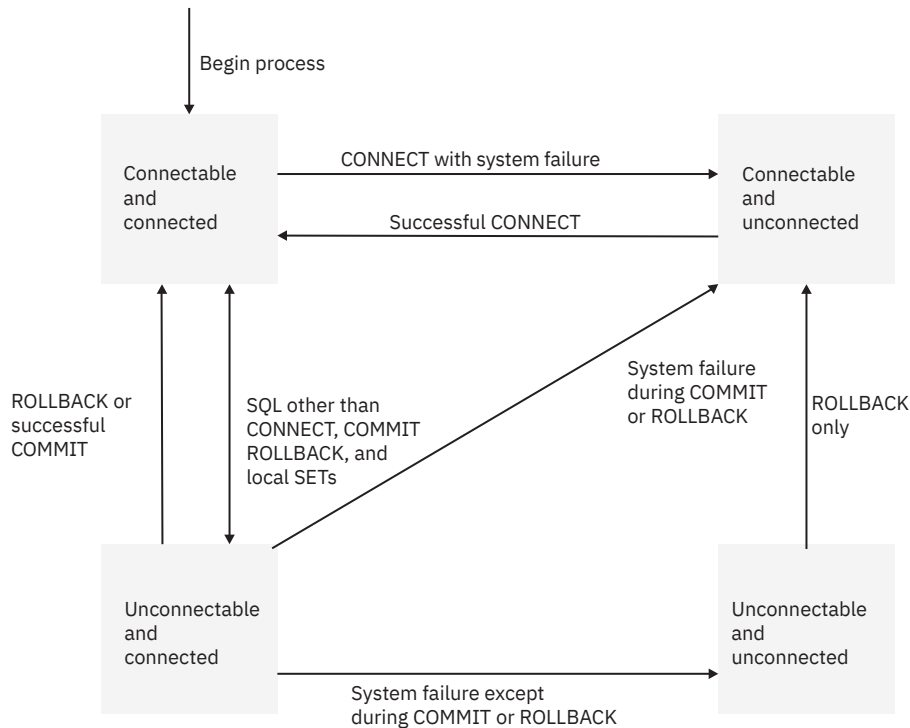

Figure 21. State transitions for an application process connection in a remote unit of work

In the following descriptions of application process connections, CONNECT can mean:

- CONNECT TO
- CONNECT RESET
- CONNECT *authorization*

It cannot mean CONNECT with no operand, which is used to return information about the current server.

Consecutive CONNECT statements can be executed successfully because CONNECT does not remove an application process from the connectable state. A CONNECT statement does not initiate a new unit of work; a unit of work is initiated by the first SQL statement that accesses data. CONNECT cannot execute successfully when it is preceded by any SQL statement other than CONNECT, COMMIT, RELEASE, ROLLBACK, or SET CONNECTION. To avoid an error, execute a commit or rollback operation before a CONNECT statement is executed.

Connectable and connected state: In the connectable and connected state, an application process is connected to a database server, and CONNECT statements that target the current server can be executed. An application process re-enters this state when either of the following is true:

- The process completes a rollback or a successful commit from an unconnectable and connected state.
- The process successfully executes a CONNECT statement from a connectable and unconnected state.

Unconnectable and connected state: In the unconnectable and connected state, an application process is connected to a database server, and only a CONNECT statement with no operands can be executed. An application process enters this state from a connectable and connected state when it executes any SQL statement other than CONNECT, COMMIT, or ROLLBACK.

Connectable and unconnected state: In the connectable and unconnected state, an application process is not connected to a database server. The only SQL statement that can be executed is CONNECT. An application process enters this state if any of the following is true:

- The process does not successfully execute a CONNECT statement from a connectable and connected state.
- The process executes a COMMIT statement when the SQL connection is in a release-pending state.
- A system failure occurs during a COMMIT or ROLLBACK from an unconnectable and connected state.

- The process executes a ROLLBACK statement from an unconnectable and unconnected state.

Other product-specific reasons can also cause an application process to enter the connectable and unconnected state.

Unconnectable and unconnected state: In the unconnectable and unconnected state, an application process is not connected to a database server and CONNECT statements cannot be executed. The only SQL statement that can be executed is ROLLBACK. An application process enters this state from an unconnectable and connected state as a result of a system failure, except during a COMMIT or ROLLBACK, at the server.

Chapter 2. Language elements in SQL

An understanding of the basic syntax of SQL and language elements that are common to many SQL statements can be helpful in using SQL with Db2 for z/OS. The most basic elements of SQL syntax are characters and tokens.

The following topics provide information about more language elements:

- [“Characters and tokens in SQL” on page 75](#)
- [“Identifiers in SQL” on page 77](#)
- [“Naming conventions in SQL” on page 79](#)
- [“SQL path” on page 85](#)
- [“Unqualified object name resolution” on page 86](#)
- [“Authorization IDs, roles, and authorization names” on page 92](#)
- [“Data types” on page 98](#)
- [“Promotion of data types” on page 129](#)
- [“Casting between data types” on page 130](#)
- [“Assignment and comparison” on page 143](#)
- [“Rules for result data types” on page 166](#)
- [“Constants” on page 170](#)
- [“Special registers” on page 177](#)
- [“Column names” on page 219](#)
- [“Variables” on page 225](#)
- [“Host structures in PL/I, C, and COBOL” on page 235](#)
- [“Host-variable arrays in PL/I, C, C++, and COBOL” on page 236](#)
- [“Functions” on page 237](#)
- [“Expressions” on page 245](#)
- [“Predicates” on page 296](#)
- [“Search conditions” on page 319](#)
- [“Options affecting SQL” on page 320](#)
- [“Mappings from SQL to XML” on page 327](#)

Characters and tokens in SQL

The most basic elements of SQL syntax are characters and tokens. Tokens are the basic syntactical units of the SQL language.

Characters

The basic symbols of keywords and operators in the SQL language are *characters*. Characters are classified as letters, digits, or special characters.

- A *letter* is any of the 26 uppercase (A–Z) and 26 lowercase (a–z) letters of the English alphabet.¹
- A *digit* is any one of the characters 0–9.
- A *special character* is any character other than a letter or a digit.

¹ Letters also include three code points reserved as alphabetic extenders for national languages (\$, #, and @ in the United States). These three code points (X'5B', X'7B', and X'7C') should be avoided because they represent different characters depending on the CCSID.

Tokens

The basic syntactical units of the SQL language are called *tokens*. A token consists of one or more characters of which none are blanks, control characters, or characters within a string constant or delimited identifier.

Tokens are classified as *ordinary* or *delimiter* tokens:

- An *ordinary token* is a numeric constant, an ordinary identifier, a host identifier, or a keyword. The following examples are ordinary tokens:

```
1      .1      +2      SELECT      E      3
```

- A *delimiter token* is a string constant, a delimited identifier, an operator symbol, or any of the special characters shown in the syntax diagrams. A question mark (?) is also a delimiter token when it serves as a parameter marker, as explained in “PREPARE statement” on page 2042. The following examples include delimiter tokens:

```
,      'string'      "fld1"      =      .
```

Spaces

A *space* is a sequence of one or more blank characters.

Control characters

A *control character* is a special character that is used for string alignment. Treated similar to a space, a control character does not cause a particular action to occur. The following table shows the control characters that Db2 recognizes and their hexadecimal values.

Table 12. Hexadecimal values for the control characters that Db2 recognizes

Control character	EBCDIC hex value	UTF-8 hex value	UTF-16 hex value
Tab	05	09	U+0009
Form feed	0C	0C	U+000C
Carriage return	0D	0D	U+000D
New line	15	C285	U+0085
Line feed	25	0A	U+000A
DBCS space	-	-	U+3000

Tokens, other than string constants and certain delimited identifiers, must not include a control character or space. A control character or space can follow a token. A delimiter token, control character, or a space must follow every ordinary token. If the syntax does not allow a delimiter token to follow an ordinary token, a control character or a space must follow that ordinary token.

Trigraph characters

The left bracket ([) and right bracket (]) characters are used in syntax to refer to an array element. Those characters cannot be specified with some CCSIDs. The following trigraphs can be used as an alternative way to specify left and right brackets:

- The string ??(can be specified in place of a left bracket ([).
- The string ??) can be specified in place of a right bracket (]).

Comments

Dynamic SQL statements can include SQL comments. Static SQL statements can include host language comments or SQL comments. Comments can be specified wherever a space can be specified, except within a delimiter token or between the keywords EXEC and SQL. In Java, SQL comments are not allowed within embedded Java expressions. There are two types of SQL comments:

Simple comments

Simple comments are introduced with two consecutive hyphens (--). Simple comments cannot continue past the end of the line.

Bracketed comments

Bracketed comments are introduced with /* and end with */. A bracketed comment can continue past the end of the line.

The following example shows how to include comments in an SQL statement within a C program. The example uses both simple and bracketed comments:

```
EXEC SQL
  CREATE VIEW PRJ_MAXPER          --projects with most support personnel
  /*
   * Returns number and name of the project
   */
  AS SELECT PROJNO, PROJNAME     -- number and name of project
     FROM DSN8910.PROJ
  /*
   * E21 is the systems support dept code
   */
  WHERE DEPTNO = 'E21'          -- systems support dept code
  AND PRSTAFF > 1;
```

For more information, see [“SQL comments” on page 1092](#).

Uppercase and lowercase characters

A token in an SQL statement can include lowercase letters, but lowercase letters in an ordinary token are folded to uppercase. However, lowercase letters are folded to uppercase in a C or Java program only if the appropriate precompiler option is specified. Delimiter tokens are never folded to uppercase.

For example, the following two statements are equivalent after folder:

```
select * from DSN8C10.EMP where lastname = 'Smith';
```

```
SELECT * FROM DSN8C10.EMP WHERE LASTNAME = 'Smith';
```

Related concepts

Identifiers in SQL

An *identifier* is a token used to form a name. An identifier in an SQL statement is an SQL identifier or a host identifier. SQL identifiers can be ordinary identifiers or delimited identifiers.

Expressions

An *expression* specifies a value and can take a number of different forms, such as a simple value, consisting of only a constant or a column name, or it can be more complex with operators, other expressions, and more.

Identifiers in SQL

An *identifier* is a token used to form a name. An identifier in an SQL statement is an SQL identifier or a host identifier. SQL identifiers can be ordinary identifiers or delimited identifiers.

Ordinary identifiers

An *ordinary identifier* is an uppercase letter followed by zero or more characters, each of which is an uppercase letter, a digit, or the underscore character. If an identifier that is not delimited contains

lowercase characters, but otherwise follows all the rules for an ordinary identifier, Db2 folds the lowercase letters to uppercase, and the identifier becomes an ordinary identifier. For more information about ordinary identifiers, see [“Characters and tokens in SQL” on page 75](#).

An ordinary identifier should not be a reserved word. If a reserved word is used as an identifier in SQL, it must be specified in uppercase and must be a delimited identifier or specified in a host variable. For a list of reserved words, see [Appendix B, “Reserved schema names and reserved words in Db2 for z/OS,” on page 2257](#).

Identifiers that contain only DBCS characters can also be ordinary identifiers, unless otherwise specified.

The following list shows the rules for forming SQL ordinary identifiers:

- The UTF-8 representation of the name must not exceed 128 bytes.
- Continuation to the next line is not allowed.

If the SQL ordinary identifier contains DBCS characters, the following additional rules apply:

- The identifier, if encoded in EBCDIC, must start with a shift-out (X'0E') and end with a shift-in (X'0F'). There must be an even number of bytes between the shift-out and the shift-in. An odd-numbered byte between those shifts must not be a shift-out. DBCS blanks (X'4040' in EBCDIC) are not acceptable between the shift-out and the shift-in.
- The identifiers are not folded to uppercase or changed in any other way.

Delimited identifiers

A *delimited identifier* is a sequence of one or more characters enclosed within escape characters. For example, if the escape character is the quotation mark (")², the following example is a delimited identifier:

```
"VIEW"
```

The escape character is the quotation mark (")² except for:

- Dynamic SQL when the field SQL STRING DELIMITER on installation panel DSNTIPF is set to the quotation mark (") and either of these conditions is true:
 - DYNAMICRULES run behavior applies. For a list of the DYNAMICRULES option values that specify run, bind, define, or invoke behavior, see [“Authorization IDs and dynamic SQL” on page 94](#).
 - DYNAMICRULES bind, define, or invoke behavior applies and installation panel field USE FOR DYNAMIC RULES is YES.

In this case, the escape character is the apostrophe (').

However, for COBOL application programs, if DYNAMICRULES run behavior does not apply and installation panel field USE FOR DYNAMICRULES is NO, a COBOL compiler option specifies whether the escape character is the quotation mark or apostrophe.

- Static SQL in COBOL application programs. A COBOL compiler option specifies whether the escape character is the quotation mark (") or the apostrophe (').

A delimited identifier can be used when the sequence of characters does not qualify as an ordinary identifier. Such a sequence, for example, could be an SQL reserved word, or it could begin with a digit. Two consecutive escape characters are used to represent one escape character within the delimited identifier. A delimited identifier that contains EBCDIC DBCS characters also must contain the necessary shift characters.

Leading and embedded blanks in the sequence are significant. Trailing blanks in the sequence are not significant. The length of a delimited identifier does not include the starting and ending escape characters. Embedded escape characters (that appear as two characters) are counted in the length as a single character.

² In CCSID 1026 and CCSID 1155, the code point for the quotation mark can be X'7F' or X'FC'. However, if the beginning delimiter is X'7F', the ending delimiter must also be X'7F'. If the beginning delimiter is X'FC', ending delimiter must also be X'FC'.

Limits for identifiers

See [Appendix A, “Limits in Db2 for z/OS,”](#) on page 2247 for length limits that Db2 imposes for identifiers.

Host identifiers

A *host identifier* is a name declared in the host program.

The rules for forming a host identifier are the rules of the host language. In non-Java programs, do not use names beginning with 'DB2', 'SQ'³, 'SQL', 'sql', 'RDI', or 'DSN' because precompilers generate host variable names that begin with these characters. In Java, do not use names beginning with '__sJT_'.

Identifier restrictions for distributed data access

The Db2 internal processing of distributed access must sometimes convert the identifiers for *authorization-name*, *procedure-name*, and *schema-name* between CCSIDs. If there is any possibility that these identifiers will be used in distributed access, restrict the identifiers to characters whose representation in Unicode UTF-8 have code points in the range 0–127. You do not need to enter the identifiers in Unicode; this restriction refers to conversion that Db2 performs internally.

Related concepts

[Characters and tokens in SQL](#)

The most basic elements of SQL syntax are characters and tokens. Tokens are the basic syntactical units of the SQL language.

[Naming conventions](#)

The rules for forming a name depend on the type of the object designated by the name.

Related reference

[Reserved schema names and reserved words in Db2 for z/OS](#)

Restrictions exist on the use of certain words that are used by Db2 for z/OS. In some cases, these names are reserved and cannot be used by application programs. In other cases, certain names are not recommended for use by application programs though not prevented from being used by the database manager.

Naming conventions in SQL

The rules for forming a name depend on the type of the object designated by the name.

Many database objects have a schema qualified name. A schema qualified name may consist of a single SQL identifier (in which case the *schema-name* is implicit) or a *schema-name* followed by a period and an SQL identifier. For more information about the rules for SQL identifiers, see [“Identifiers in SQL”](#) on page 77.

The syntax diagrams use different terms for different types of names. The following list defines these terms.

accelerator-name

A name that identifies an accelerator-only table. An accelerator name is 1 to 8 uppercase characters or digits. The name must be unique within the Db2 subsystem or data sharing group.

alias-name

A qualified or unqualified name that designates an alias. A fully qualified alias name is a three-part name. The first part is a location name that designates the DBMS at which the alias is defined. The second part is a schema name. The third part is an SQL identifier. A period must separate each of the parts.

A two-part sequence is implicitly qualified by the location name of the current server. The first part is a schema name. The second part is an SQL identifier. A period must separate the two parts.

³ 'SQ' is allowed in C, COBOL, and REXX.

A one-part or unqualified alias name is an SQL identifier with two implicit qualifiers. The first implicit qualifier is the location name of the current server. The second is a schema name, which is determined by the rules specified in [“Unqualified alias, index, JAR file, mask, permission, sequence, table, trigger, and view names”](#) on page 86.

For more information, see [“Aliases”](#) on page 88.

array-type-name

A qualified or unqualified name that designates an array type.

A qualified array type name is a two-part name. The first part is the schema name of the array type. The second part is an SQL identifier. A period must separate each of the parts.

An unqualified array type name is an SQL identifier with an implicit qualifier. The implicit qualifier is the schema name, which is determined by the context in which the array type appears, as described by the rules in [“Unqualified object name resolution”](#) on page 86.

authorization-name

An SQL identifier that designates a set of privileges. It can also designate a user, a group of users, or a role. For a user or a group of users, Db2 does not control this property. For a role, Db2 does control this property. See [“Authorization IDs, roles, and authorization names”](#) on page 92 for the distinction between an authorization name and an authorization ID.

aux-table-name

A qualified or unqualified name that designates an auxiliary table. The rules for the name are the same as the rules for *table-name*. See [table-name](#).

bpname

A name that identifies a buffer pool. The following list shows the names of the different buffer pool sizes.

4KB

BP0, BP1, BP2, ..., BP49

8KB

BP8K0, BP8K1, BP8K2, ..., BP8K9

16KB

BP16K0, BP16K1, BP16K2, ..., BP16K9

32KB

BP32K, BP32K1, BP32K2, ..., BP32K9

built-in-type

A qualified or unqualified name that identifies an IBM-supplied data type. A qualified name is SYSIBM followed by a period and the name of the built-in data type. An unqualified name has an implicit qualifier, the schema name, which is determined by the rules in [“Unqualified object name resolution”](#) on page 86.

catalog-name

An SQL identifier that designates an integrated catalog facility (ICF) catalog. The identifier must start with a letter and must not include special characters, or the alphabetic extenders for national languages (\$, #, and @ in the United States). These three code points (X'5B', X'7B', and X'7C') should be avoided because they represent different characters depending on the CCSID.

clone-table-name

A qualified or unqualified name that designates the name of a clone table. See the definition of *table-name* for more information about qualification of table names.

collection-id

An SQL identifier that identifies a collection of packages, such as a collection ID as a qualifier for a package ID.

column-name

A qualified or unqualified name that designates a column of a table or view.

A qualified column name is a qualifier followed by a period and an SQL identifier. The qualifier is a table name, a view name, a synonym, an alias, or a correlation name. The unqualified column name is an SQL identifier.

constraint-name

An SQL identifier that designates a primary key, check, referential, or unique constraint on a table.

context-name

An SQL identifier that designates a trusted context.

correlation-name

An SQL identifier that designates a table, a view, or individual rows of a table or view.

cursor-name

An SQL identifier that designates an SQL cursor. In SQLJ, *cursor-name* is a host variable (with no indicator variable) that identifies an instance of an iterator.

database-name

An SQL identifier that designates a database. The identifier must start with a letter and must not include special characters.

descriptor-name

A host identifier that designates an SQL descriptor area (SQLDA). See “Host variables” on page 227 for a description of a host identifier. A descriptor name never includes an indicator variable.

distinct-type-name

A qualified or unqualified name that designates a distinct type.

A qualified distinct type name is a two-part name. The first part is the schema name of the distinct type. The second part is an SQL identifier. A period must separate each of the parts.

An unqualified distinct type name is an SQL identifier with an implicit qualifier. The implicit qualifier is the schema name, which is determined by the context in which the distinct type appears as described by the rules in [“Unqualified type, function, procedure, global variable, and specific names” on page 87](#).

external-program-name

A name that specifies the program that runs when the function is invoked or the procedure name is specified in a CALL statement.

function-name

A qualified or unqualified name that designates a user-defined function, a cast function that was generated when a distinct type was created, or a built-in function.

A qualified function name is a two-part name. The first part is the schema name of the function. The second part is an SQL identifier. A period must separate each of the parts.

An unqualified function name is an SQL identifier with an implicit qualifier. The implicit qualifier is the schema name, which is determined by the context in which the unqualified name appears as described by the rules in [“Unqualified type, function, procedure, global variable, and specific names” on page 87](#).

global-variable-name

A qualified or unqualified name that designates a global variable.

A qualified global variable name is a two-part name. The first part is the schema name of the global variable. The second part is an SQL identifier. A period must separate each of the parts.

An unqualified global variable name is an SQL identifier with an implicit qualifier. The implicit qualifier is the schema name, which is determined by the context in which the unqualified name appears as described by the rules in [“Unqualified type, function, procedure, global variable, and specific names” on page 87](#).

host-label

A token that designates a label in a host program.

host-variable

A sequence of tokens that designates a host variable. A host variable includes at least one host identifier, as explained in [“Host variables” on page 227](#).

index-name

A qualified or unqualified name that designates an index.

A qualified index name is an authorization ID or schema name followed by a period and an SQL identifier.

An unqualified index name is an SQL identifier with an implicit qualifier. The implicit qualifier is an authorization ID, which is determined by the context in which the unqualified name appears as described by the rules in [“Unqualified object name resolution” on page 86](#).

For an index on a declared temporary table, the qualifier must be SESSION.

FL 502 key-label-name

An SQL identifier that corresponds to the value of the Integrated Cryptographic Service Facility (ICSF) key label. A keylabel-name can consist of up to 64 characters. The first character must be a letter or national character (#, \$, @). It is recommended that the name not include national characters (@ (X'7C'), # (X'7B'), or \$ (X'5B')). The identifier must not include the underscore (_) character. The characters allowed in the delimited form are the same as those allowed in the ordinary form, except that it can contain a period (.), but the period cannot be the first character. For more information, see [Key label \(z/OS ICSF\)](#).

location-name

An SQL identifier that designates the name of a location. A location name is 1 to 16 bytes, does not include alphabetic extenders (national characters), lowercase letters, or Katakana characters. The characters allowed in the delimited form are the same as those allowed in the ordinary form.

mask-name

A qualified or unqualified name that designates a mask.

A qualified mask name is a two-part name. The first part is the schema name. The second part is an SQL identifier. A period must separate each of the parts.

A one-part or unqualified mask name is an SQL identifier with an implicit qualifier. The implicit qualifier is an authorization ID, which is determined by the context in which the unqualified name appears as described by the rules in [“Unqualified object name resolution” on page 86](#).

package-name

A qualified or unqualified name that designates a package. The unqualified form of a *package-name* is an SQL identifier. A *package-name* must not be a delimited identifier that includes lowercase letters or special characters. A *package-name* in an SQL statement must be qualified. In some contexts outside of SQL, a package name can be specified as an unqualified name.

parameter-name

An SQL identifier that designates a parameter in an SQL procedure or SQL function.

permission-name

A qualified or unqualified name that designates a permission.

A qualified permission name is a two-part name. The first part is the schema name. The second part is an SQL identifier. A period must separate each of the parts.

A one-part or unqualified permission name is an SQL identifier with an implicit qualifier. The implicit qualifier is an authorization ID, which is determined by the context in which the unqualified name appears as described by the rules in [“Unqualified object name resolution” on page 86](#).

plan-name

An SQL identifier that designates an application plan. The identifier must not be a delimited identifier that includes lowercase letters or special characters.

procedure-name

A qualified or unqualified name that designates a stored procedure.

A fully qualified procedure name is a three-part name. The first part is a location name that identifies the DBMS at which the procedure is stored. The second part is the schema name of the stored procedure. The third part is an SQL identifier. A period must separate each of the parts in a qualified name.

A two-part procedure name is implicitly qualified with the location name of the current server. The first part is the schema name of the stored procedure. The second part is an SQL identifier. A period must separate the two parts.

A one part, or unqualified, procedure name is an SQL identifier with two implicit qualifiers. The first implicit qualifier is the location name of the current server. The second implicit qualifier is the schema name, which is determined by the context in which the unqualified name appears, as described by the rules in [“Unqualified object name resolution”](#) on page 86.

The SQL identifier in a qualified or unqualified name must not be an asterisk (*).

profile-name

An SQL identifier that corresponds to a RACF profile name.

program-name

An SQL identifier that designates an exit routine.

role-name

An SQL identifier that designates a role. The identifier cannot begin with the characters SYS and cannot be ACCESSCTRL, DATAACCESS, DBADM, DBCTRL, DBMAINT, NONE, NULL, PACKADM, PUBLIC, SECADM, or SQLADM.

routine-version-id

An SQL identifier of up to 64 EBCDIC bytes that designates a version of a routine. The UTF-8 representation of the identifier must not exceed 122 bytes.

savepoint-name

An SQL identifier that designates a savepoint.

schema-name

An SQL identifier that provides a logical grouping for SQL objects. A *schema-name* is used as a qualifier of the name of SQL objects.

seclabel-name

An SQL identifier that corresponds to the value of the RACF security label. It is recommended that the name not include national characters (@ (X'7C'), # (X'7B'), or \$ (X'5B')). If the table is a Unicode table and the security label name does include national characters, an error might be issued if substitution occurs when Db2 converts the value from EBCDIC to Unicode.

sequence-name

A qualified or unqualified name that designates a sequence.

A qualified sequence name is a two-part name. The first part is the schema name. The second part is an SQL identifier. A period must separate each of the parts.

A one-part or unqualified sequence name is an SQL identifier with an implicit qualifier. The implicit qualifier is an authorization ID, which is determined by the context in which the unqualified name appears as described by the rules in [“Unqualified alias, index, JAR file, mask, permission, sequence, table, trigger, and view names”](#) on page 86.

server-name

An SQL identifier that designates an application server. The identifier must start with a letter and must not include lowercase letters or special characters.

specific-name

A qualified or unqualified name that designates a unique name for a user-defined function.

A qualified specific name is a two-part name. The first part is the schema name. The second part is an SQL identifier, and it must not be an asterisk (*). A period must separate each of the parts.

An unqualified specific name is an SQL identifier with an implicit qualifier. The implicit qualifier is the schema name, which is determined by the context in which the unqualified name appears as

described by the rules in [“Unqualified type, function, procedure, global variable, and specific names” on page 87](#).

A specific name can be used to identify a function to alter, comment on, drop, grant privileges on, revoke privileges from, or be the source function for another function. A specific name cannot be used to invoke a function. In addition to being used in certain SQL statements, a specific name must be used in Db2 commands to uniquely identify a function.

SQL-condition-name

An SQL identifier that designates a condition in an SQL routine or trigger.

SQL-label

An SQL identifier that designates a label in an SQL routine or trigger.

SQL-parameter-name

A qualified or unqualified name that designates a parameter in an SQL routine body. The unqualified form of an *SQL-parameter-name* is an SQL identifier. The qualified form is a *function-name* or *procedure-name* followed by a period and an SQL identifier.

SQL-variable-name

A qualified or unqualified name that designates a variable in an SQL routine or trigger body. The unqualified form of an *SQL-variable-name* is an SQL identifier. The qualified form is an *SQL-label* followed by a period (.) and an SQL identifier.

statement-name

An SQL identifier that designates a prepared SQL statement.

stogroup-name

An SQL identifier that designates a storage group.

synonym

An SQL identifier that designates a synonym, a table, or a view. The table or view must exist at the current server. A qualified name is never interpreted as a synonym.

table-name

A qualified or unqualified name that designates a table.

A fully qualified table name is a three-part name. The first part is a location name that designates the DBMS at which the table is stored. The second part is a schema name. The third part is an SQL identifier. A period must separate each of the parts.

A two-part table name is implicitly qualified by the location name of the current server. The first part is a schema name. The second part is an SQL identifier. A period must separate the two parts.

A one-part or unqualified table name is an SQL identifier with two implicit qualifiers. The first implicit qualifier is the location name of the current server. The second is a schema name, which is determined by the rules set forth in [“Unqualified alias, index, JAR file, mask, permission, sequence, table, trigger, and view names” on page 86](#). For a declared temporary table, the qualifier (the second part in a three-part name and the first part in a two-part name) must be SESSION. For complete details on specifying a name when a declared temporary table is defined and then later referring to that declared temporary table in other SQL statements, see [“DECLARE GLOBAL TEMPORARY TABLE statement” on page 1830](#).

table-space-name

An SQL identifier that designates a table space of an identified database. The identifier must start with a letter and must not include special characters. If a database is not identified, DSNCB04 is implicit.

trigger-name

A qualified or unqualified name that designates a trigger.

A qualified trigger name is a two-part name. The first part is the schema name of the trigger. The second part is an SQL identifier. A period must separate each of the parts.

An unqualified trigger name is an SQL identifier with an implicit qualifier. The implicit qualifier is the schema name, which is determined by the context in which the unqualified name appears as described by the rules in [“Unqualified alias, index, JAR file, mask, permission, sequence, table, trigger, and view names” on page 86](#).

trigger-version-id

An SQL identifier of up to 64 EBCDIC bytes that designates a version of a trigger. The UTF-8 representation of the identifier must not exceed 122 bytes.

view-name

A qualified or unqualified name that designates a view.

A fully qualified view name is a three-part name. The first part is a location name that designates the DBMS where the view is defined. The second part is a schema name. The third part is an SQL identifier. A period must separate each of the parts.

A two-part view name is implicitly qualified by the location name of the current server. The first part is a schema name. The second part is an SQL identifier. A period must separate the two parts.

A one-part or unqualified view name is an SQL identifier with two implicit qualifiers. The first implicit qualifier is the location name of the current server. The second is a schema name, which is determined by the context in which the unqualified name appears as described by the rules in [“Unqualified alias, index, JAR file, mask, permission, sequence, table, trigger, and view names” on page 86](#).

XML-attribute-name

An identifier that is used as an XML attribute name.

XML-element-name

An identifier that is used as an XML element name.

Related conceptsIdentifiers in SQL

An *identifier* is a token used to form a name. An identifier in an SQL statement is an SQL identifier or a host identifier. SQL identifiers can be ordinary identifiers or delimited identifiers.

Related referenceReserved schema names and reserved words in Db2 for z/OS

Restrictions exist on the use of certain words that are used by Db2 for z/OS. In some cases, these names are reserved and cannot be used by application programs. In other cases, certain names are not recommended for use by application programs though not prevented from being used by the database manager.

SQL path

The *SQL path* is an ordered list of schema names. Db2 uses the path to resolve the schema name for certain unqualified object names that appear in any context other than as the main object of an ALTER, CREATE, DROP, COMMENT, GRANT, RENAME, or REVOKE statement.

Db2 uses the path to resolve the schema name for the following object names:

- data types (both built-in types and distinct types)
- functions
- stored procedures
- global variables

Searching through the path from left to right, Db2 implicitly qualifies the object name with the first schema name in the SQL path that contains the same object with the same unqualified name for which the user has appropriate authorization. For functions, Db2 uses a process called function resolution in conjunction with the SQL path to determine which function to choose because several functions with the same name and number of parameters but different parameter data types might be defined in the same schema or other schemas in the SQL path. (For details, see [“Function resolution” on page 239](#).) For procedures, Db2 selects a matching procedure name only if the number of parameters is also the same.

The SQL path does not apply to unqualified procedure names in ASSOCIATE LOCATOR and DESCRIBE PROCEDURE statements. For these statements, an implicit schema name is not generated.

For an example of how Db2 uses the SQL path to resolve the schema name, assume that the SQL path is SMITH, XGRAPHIC, SYSIBM, and that an unqualified distinct type name MYTYPE was specified. Db2 looks for MYTYPE first in schema SMITH, then XGRAPHIC, and then SYSIBM.

The PATH option establishes the SQL path that is used to resolve:

- Unqualified data type, global variable, and function names in static SQL statements
- Unqualified procedure names in SQL CALL statements that specify the procedure name as an identifier token (CALL *procedure-name*)

If the PATH option was not specified when the plan or package was created or last rebound or when native SQL procedure was defined or last changed, the default value of the SQL path is: SYSIBM, SYSFUN, SYSPROC, *plan or package qualifier*.

The CURRENT PATH special register determines the SQL path used to resolve:

- Unqualified data type, global variable, and function names in dynamic SQL statements
- Unqualified procedure names in SQL CALL statements that specify the procedure name in a host variable (CALL *host-variable*)

Generally, the initial value of the CURRENT PATH special register is one of the following:

- The value of the PATH option
- "SYSIBM", "SYSFUN", "SYSPROC", "SYSIBMADM", *value of CURRENT SQLID special register* if the PATH option was not specified.

If schema "SYSIBM", "SYSFUN", "SYSPROC", "SYSIBMADM" is not explicitly specified in the SQL path, the schema is implicitly assumed at the front of the path; if all are not specified, they are assumed in the order of "SYSIBM", "SYSFUN", "SYSPROC", "SYSIBMADM".

For example, assume that the SQL path is explicitly specified as SYSIBM, GEORGIA, SMITH. As implicitly assumed schemas, SYSFUN, SYSPROC, and SYSIBMADM are added to the beginning of the explicit path effectively making the path:

SYSFUN, SYSPROC, SYSIBMADM, SYSIBM, GEORGIA, SMITH

For more information about the SQL path for dynamic SQL, see [“CURRENT PATH special register”](#) on page 200 and [“SET PATH statement”](#) on page 2163.

Unqualified object name resolution

Most object names are implicitly or explicitly qualified with a schema name. Synonyms are an exception.

A synonym has a single part name. When Db2 encounters an unqualified name, Db2 must determine which object to process. This process is called *name resolution*.

When Db2 encounters a single part name in a context where an alias, table, view, or synonym can be specified, Db2 first checks to see if the name refers to a synonym that is defined by the current user.

Unqualified object names, other than synonyms, are implicitly qualified. The rules for qualifying a name differ depending on the type of object that the name identifies.

Unqualified alias, index, JAR file, mask, permission, sequence, table, trigger, and view names

The default schema is determined as follows:

- For static SQL statements, the default schema is the identifier specified in the QUALIFIER option of the BIND subcommand or the CREATE or ALTER statement for a SQL routine or trigger. If this option is not in effect for the plan, package, or native SQL procedure, the default schema is the authorization ID of the owner of the plan, package, or native SQL procedure.

- For dynamic SQL statements, the behavior as specified by the combination of the DYNAMICRULES option and the run time environment determines the default schema. (For a list of these behaviors and the DYNAMICRULES values that determine them, see [Table 14 on page 94](#)).
 - If *DYNAMICRULES run behavior* applies, the default schema is the schema in the CURRENT SCHEMA special register. Run behavior is the default.
 - If *bind behavior* applies, the default schema is the identifier that is implicitly or explicitly specified in the QUALIFIER option, as explained for static SQL statements.
 - If *define behavior* applies, the default schema is the owner of the function or stored procedure (the owner is the definer).
 - If *invoke behavior* applies, the default schema is the authorization ID of the invoker of the function or stored procedure.

Exception: For bind, define, and invoke behavior, the default schema of PLAN_TABLE, DSN_STATEMENT_TABLE, and DSN_FUNCTION_TABLE (output from the EXPLAIN statement) is always the value in special register CURRENT SQLID.

Unqualified type, function, procedure, global variable, and specific names

The qualification of unqualified type (built-in type, distinct type, or array type), function, stored procedure, global variable, and specific names depends on the SQL statement in which the unqualified name appears.

- If an unqualified name is the main object of an ALTER, CREATE, COMMENT, DROP, GRANT, or REVOKE statement, the name is implicitly qualified with a schema name as follows:
 - In a static statement, the implicit schema name is the identifier specified in the QUALIFIER option of the BIND subcommand or the CREATE or ALTER statement for a SQL routine or trigger. If this option is not in effect for the package or procedure, the implicit qualifier is the authorization ID of the owner of the package or procedure.
 - In a dynamic statement, the implicit schema name is the schema in the CURRENT SCHEMA special register.
- Otherwise, the implicit schema name for the unqualified name is determined as follows:
 - For distinct type and array type names, Db2 searches the SQL path and selects the first schema in the path such that the data type exists in the schema and the user has authorization to use the type.
 - For global variable names, Db2 searches the SQL path and selects the first schema in the path such that the global variable exists in the schema and the user has authorization to use the global variable.
 - For function names, Db2 uses the SQL path in conjunction with function resolution, as described in [“Function resolution” on page 239](#).
 - For stored procedure names in CALL statements, Db2 searches the SQL path and selects the first schema in the path such that the schema contains a procedure with the same name and number of parameters and the user has authorization to use the procedure.
 - For stored procedure names in ASSOCIATE LOCATORS and DESCRIBE PROCEDURE statements, Db2 does not use the SQL path because an implicit schema name is not generated for these statements.

For information about the SQL path, see [“SQL path” on page 85](#).

Related reference

[QUALIFIER bind option \(Db2 Commands\)](#)

[DYNAMICRULES bind option \(Db2 Commands\)](#)

[CREATE PROCEDURE statement \(SQL - native procedure\)](#)

The CREATE PROCEDURE statement defines an SQL procedure, or a version of a procedure, at the current server and specifies the source statements for the procedure.

[ALTER PROCEDURE statement \(SQL - native procedure\)](#)

The ALTER PROCEDURE statement changes the definition of an SQL procedure at the current server. The procedure options, parameter names, and routine body can be changed and additional versions of the procedure can be defined and maintained using the ALTER PROCEDURE statement.

[CREATE TRIGGER statement \(advanced trigger\)](#)

[ALTER TRIGGER statement \(advanced trigger\)](#)

[CREATE FUNCTION statement \(compiled SQL scalar function\)](#)

The CREATE FUNCTION (compiled SQL scalar) statement defines a compiled SQL scalar function at the current server and specifies the source statements for the function. The body of the function is written in the SQL procedural language. The function returns a single value each time it is invoked.

[ALTER FUNCTION statement \(compiled SQL scalar function\)](#)

The ALTER FUNCTION (compiled SQL scalar) statement changes the description of a user-defined compiled SQL scalar function at the current server. The function options, parameter names, and routine body can be changed and additional versions of the procedure can be defined and maintained using the ALTER FUNCTION statement.

[CURRENT SQLID special register](#)

CURRENT SQLID specifies the SQL authorization ID of the process.

[EXPLAIN statement](#)

Aliases

An *alias* is an alternative name for an object such as a table, view, sequence, or another alias. It can be used to reference an object wherever that object can be referenced directly.

The option of referencing an object by an alias is not explicitly shown in the syntax diagrams or mentioned in the description of SQL statements.

Like tables, views, and sequences, an alias can be created, dropped, and associated with a comment. No authority is necessary to use an alias. However, access to the objects that are referred to by the alias still requires the appropriate authorization for the current statement.

An alias is created using the CREATE ALIAS statement.

An alias name designates an alias when it is preceded by the keyword ALIAS, as in CREATE ALIAS, DROP ALIAS, COMMENT ON ALIAS, and LABEL for an ALIAS. In all other contexts, an alias name designates a table, a view, or a sequence. For example, COMMENT ON ALIAS A specifies a comment about the alias A, whereas COMMENT ON TABLE A specifies a comment about the table or view designated by A.

An alias for a table or a view can be defined at a local server to refer to a table or a view that is at the current server or a remote server. An alias name for a table or view can be used wherever the table name or view name can be used to refer to the table or view in an SQL statement. The rules for forming an alias name for a table or view are the same as the rules for forming a table name or a view name. A fully qualified alias name (a three-part name) can refer to an alias at a remote server. However, the table or view identified by the alias at the remote server must exist at the remote server.

An alias for a sequence can be defined at the current server. An alias name for a sequence can be used wherever the sequence name can be used to refer to the sequence in an SQL statement. The rules for forming an alias name for a sequence are the same as the rules for forming a sequence name.

Statements that use three-part names and refer to distributed data result in DRDA access to the remote site. DRDA access for three-part names is used when the package that contains the query to distributed data is bound using the bind option DBPROTOCOL(DRDA), or the value of the DATABASE PROTOCOL field on installation panel DSNTIP5 is DRDA. When an application program uses three-part name aliases for remote table or view objects and DRDA access, the application program must be bound at each location that is specified in the three-part name. Also, each alias must be defined at the local site. An alias at a remote site can refer to another server if a referenced alias eventually refers to a table or view.

The effect of using an alias in an SQL statement is the same as text substitution. For example, if A is an alias for table Q.T, one of the steps involved in the preparation of SELECT * FROM A is the replacement of 'A' by 'Q.T'.

If an alias is defined as a public alias, it can be referenced by its unqualified name without any impact from the current default schema name. It can also be referenced using the schema qualifier SYSPUBLIC.

Related concepts

[Synonyms \(deprecated\)](#)

A synonym is an alternate name for a table or view. A synonym can be used to reference a table or view in cases where an existing table or view can be referenced. However, Db2 no longer supports the creation of new synonyms.

Related reference

[CREATE ALIAS statement](#)

The CREATE ALIAS statement defines an alias for a table, a view, or a sequence. The definition is recorded in the Db2 catalog at the current server.

Synonyms (deprecated)

A synonym is an alternate name for a table or view. A synonym can be used to reference a table or view in cases where an existing table or view can be referenced. However, Db2 no longer supports the creation of new synonyms.

Unsupported function: [FL 504](#) Beginning in Db2 12, packages bound with APPLCOMPAT(V12R1M504) or higher cannot issue CREATE SYNONYM statements. Although there are some differences, you can use aliases instead. Unlike synonyms, aliases behave the same for all Db2 family products. For more information about aliases, see [Aliases \(Introduction to Db2 for z/OS\)](#) and [“CREATE ALIAS statement”](#) on page 1415. Existing synonyms remain supported, but support might be removed in the future.

Differences between synonyms and aliases

The following table summarizes the differences between aliases and synonyms, which are deprecated.

Table 13. Differences between synonyms and aliases

Characteristic	Synonyms (deprecated)	Aliases
FL 504 Can be created in application compatibility V12R1M504 and higher?	No	Yes
Requires authorization to create?	No	Yes
Can be defined on objects not at the current server?	No	Yes
Can be defined on the name of an object that does not yet exist?	No	Yes, but the object must exist when the alias is used
Is dropped when referenced objects are dropped?	Yes	No
Uses a qualified object name for the object?	No, uses a one-part name	Yes
Can be referenced or used by users other than the object owner?	No	Yes

The option of referencing a table or view by a synonym is not explicitly shown in the syntax diagrams or mentioned in the description of SQL statements. But synonyms can be referred to in an SQL statement.

Like tables and views, a synonym can be dropped, and associated with a comment. No authority is necessary to use a synonym. However, access to the tables and views that are referenced by the synonym still requires the appropriate authorization for the current statement.

A synonym name designates a synonym when it is preceded by the keyword SYNONYM, as in DROP SYNONYM. In all other contexts, a synonym designates a table or a view. In all other contexts, a synonym designates a local table or view and can be used wherever the name of a table or view can be used in an SQL statement.

The effect of using a synonym in an SQL statement is the same as text substitution. For example, if S is a synonym for Q.T, one of the steps involved in the preparation of SELECT * FROM S is the replacement of 'S' by 'Q.T'.

Related concepts

Aliases

An *alias* is an alternative name for an object such as a table, view, sequence, or another alias. It can be used to reference an object wherever that object can be referenced directly.

Related reference

CREATE ALIAS statement

The CREATE ALIAS statement defines an alias for a table, a view, or a sequence. The definition is recorded in the Db2 catalog at the current server.

Authorization, privileges, permissions, masks, and object ownership

Users (as identified by an authorization ID) can successfully execute SQL statements only if they have the authority to perform the specified operation. For example, to create a table, a user must be authorized to create tables.

The two forms of authorization are administrative authority and privileges.

Administrative authority

The holder of administrative authority is charged with the task of controlling Db2 and is responsible for the safety and integrity of the data.

Those with SYSADM authority implicitly have all privileges on all objects and control who will have access to Db2 and the extent of this access.

Those with SECADM authority manage security policies by enforcing row and column access control for tables that contain sensitive data. They define row permissions and column masks, which describe how tables that use row or column access controls should be accessed and which determine whether a trigger or a user-defined function is considered secure for those tables.

Privileges

Privileges are those activities that a user is allowed to perform. Authorized users can create objects, have access to objects that they own, and can pass on privileges on the objects that they own to other users by using the GRANT statement. Privileges can be granted to specific users or to PUBLIC. PUBLIC specifies that a privilege is granted to all users (including to future users).

The REVOKE statement can be used to revoke previously granted privileges.

Row permissions and column masks

A *row permission* is a database object that expresses an access control rule for a row of a specific table. A row permission is in the form of a search condition that describes to which rows users have access. Row permissions are applied after table privileges (like SELECT or INSERT) are checked.

A *column mask* is a database object that expresses an access control rule for a specific column in a table. A column mask is in the form of a CASE expression that describes to which column values users have access. Column masks are applied after table privileges (like SELECT or INSERT) are checked.

Row permissions and column masks can be created, changed, and dropped only by those with SECADM authority by using the CREATE MASK, CREATE PERMISSION, and DROP statements. The definition of a permission or a mask can reference other objects. Those with SECADM authority do not need additional privileges to reference those objects, such as SELECT privilege to retrieve from a table or EXECUTE privilege to invoke a user-defined function, in the definition of the row permission or column mask. Multiple row permissions and column masks can be created for a table. Only one

column mask can be created for each column in a table. A row permission or a column mask can be created before row or column access control is enforced for a table. The definition of the row permission and the column mask is stored in the Db2 catalog. However, the permission and the mask do not take effect until the ALTER TABLE statement with the ACTIVATE ROW ACCESS CONTROL clause is used to enforce row access control or the ACTIVATE COLUMN ACCESS CONTROL clause is used to enforce column access control on the table.

When an ALTER TABLE statement is used to explicitly activate row access control for a table, a default row permission is implicitly created for the table which prevents all access to the table. After row access controls have been activated for a table, if the table is referenced explicitly in a data change statement and if multiple row permissions are defined for the table, a row access control search condition is derived by using the logical OR operator with the search condition of each defined row permission.

When an ALTER TABLE statement is used to explicitly activate column access control for a table, access to the table is not restricted. However, if the table is referenced in a data change statement, all column masks that have been created for the table are applied to mask the column values that are referenced in the output of the queries or to determine the column values that are used in the data change statements.

The authorization ID or role for the statement does not need authority to reference objects that are specified in the definition of the row permission or column mask.

Object ownership

When an object is created, one authorization ID is assigned ownership of the object. Ownership means that the user is authorized to reference the object in any applicable SQL statement. The privileges on the object can be granted by the owner, and cannot be revoked from the owner. Owners of views only receive the level of privileges that they have on the underlying table or view. The owner of the object that is being created is determined as follows:

- If the schema qualifier is not explicitly specified, the owner depends on how the CREATE statement is issued:
 - If the CREATE statement is embedded in a program, the owner of the object that is being created is the authorization ID that serves as the implicit qualifier for unqualified object names. This is the authorization ID that is in the QUALIFIER option when the plan, package, or native SQL procedure (that contains the CREATE statement) is created or last changed. If the QUALIFIER option is not used, the owner of the object is the authorization ID in the OWNER option when the plan, package, or native SQL procedure is created or last changed. If the OWNER option is not used, the owner is the owner of the plan, package, or native SQL procedure. If the plan or package was last bound in a trusted context that is defined with the ROLE AS OBJECT OWNER clause, a role is the owner.
 - If the CREATE statement is dynamically prepared, the owner of the object that is being created is the authorization ID of the process.
 - If the CREATE statement is execute in a trusted context that is defined with the ROLE AS OBJECT OWNER clause, the role of the primary authorization ID is the owner.
- If the schema qualifier is explicitly specified, the owner depends on the type of object that is being created unless the CREATE statement is executed in a trusted context that is defined with the ROLE AS OBJECT OWNER clause. When the CREATE statement is executed in a trusted context that is defined with the ROLE AS OBJECT OWNER clause, the owner of the object is determined as follows:
 - If the CREATE statement is embedded in a program, the role that owns the plan or package is the owner of the object.
 - If the CREATE statement is dynamically prepared, the primary authorization ID is the owner.

If the schema qualifier is explicitly specified, and the CREATE statement is not executed in a trusted context that is defined with the ROLE AS OBJECT OWNER clause, the owner depends on the type of object that is being created: :

- For an alias, auxiliary table, created global temporary table, table, or view, the owner of the object that is being created is the same as the explicit schema name.

- For a user-defined distinct type, user-defined function, procedure, sequence, JAR files, or trigger, the owner of the object that is being created is the authorization ID of the process.

The rules that determine ownership of row permissions and column masks are the same as those that determine ownership of objects like user-defined distinct types, user-defined functions, procedures, sequences, JAR files, or trigger.

The owner of a row permission or a column mask does not have implicit owner privileges. Only users with SECADM authority can manage and maintain row permissions and column masks.

Authorization IDs, roles, and authorization names

Processes can successfully execute SQL statements only if they have the necessary authority. A process derives this authority from its authorization IDs. An authorization ID can also designate a user, a group of users, or a role.

An *authorization ID* is a character string that is associated with a process that is checked to determine the authority to perform a specified operation.

Db2 does not control the association of users to user groups. However, Db2 does control the association between users and roles when a trusted context is defined.

Db2 uses authorization IDs to provide authorization checking of SQL statements.

Whenever a connection is established between Db2 and a process, Db2 obtains an authorization ID and passes it to the authorization connection or sign-on exit routine. The list of one or more authorization IDs that is returned by the exit routine are used as the authorization IDs of the process. If the process is running in a trusted context with a role, the authorization IDs of the process includes this role.

Every process has exactly one primary authorization ID. Any other authorization IDs of a process are secondary authorization IDs. The use of these authorization IDs depends on the type of process (bind process, application process, or process involved in the creation of objects).

Primary authorization ID

An authorization ID that is used to established a connection between Db2 and an application process.

Secondary authorization ID

An authorization ID that is associated with a primary authorization ID.

Secondary authorization IDs includes all the authorization IDs that have been associated with a primary authorization ID by the connection or sign-on authorization exit routine, the CURRENT SQLID (when different from the primary authorization ID), and other authorization IDs like the stored procedure definer and call package owner for stored procedure package checking.

Authorization ID of the process

The user's primary and secondary authorization IDs. If the process is running in a trusted context with a role, the authorization IDs of the process includes this role.

A *role* is a database entity that groups together one or more privileges. A role is available only when the process is run in a trusted context. Users are associated with a role in the definition of a trusted context.

A trusted context can have a default role, specific roles for individual users, or no roles at all. A user in a trusted context can have only one active role. This is the role that is specifically defined for the user or the default role of the trusted context. The following restrictions apply to roles:

- A role cannot be a primary authorization ID.
- A role cannot be set by using a SET CURRENT SQLID statement.
- A role can be the schema qualifier of an object. However, when it is used as a schema qualifier, a role is considered to be a character string and does not add any implicit schema privileges (ALTERIN, CREATEIN, or DROPIN) to this role.
- A role must already exist for privileges to be granted to it.

The role that is in effect for a user is considered to be one of the secondary authorization IDs of the user.

Do not confuse an *authorization-name* that is specified in an SQL statement with an authorization ID of a process.

Example

Assume that SMITH is your TSO logon, DYNAMICRULES run behavior is in effect, and you execute the following statements interactively:

```
CREATE TABLE TDEPT LIKE DSN8C10.DEPT;  
GRANT SELECT ON TDEPT TO KEENE;
```

Also assume that your site has not replaced the default exit routine for connection authorization and that you have not executed the SET CURRENT SQLID statement. Thus, when the GRANT statement is prepared and executed by SPUFI, the SQL authorization ID is SMITH. KEENE is an authorization name that is specified in the GRANT statement.

Authorization to execute the GRANT statement is checked against SMITH. The authorization rule is that the privilege set that is designated by SMITH must include the SELECT privilege with the GRANT option on SMITH.TDEPT. No check that involves KEENE is performed. If the GRANT statement specifies a role, the existence of the role is checked.

Authorization IDs and schema names

If an authorization ID is not a role and has the same name as the name of a schema, that authorization ID implicitly has the following privileges for that schema:

- CREATEIN privilege
- ALTERIN privilege
- DROPIN privilege

Authorization IDs and statement preparation

The authorization ID that is specified as the owner of the plan or package must be one of the authorization IDs of the bind process. The owner can be set to any value if one of the authorization IDs of the bind process has SYSADM or SYSCTRL authority.

A process that creates a plan or package is called a *bind process*. The connection with Db2 is the result of the execution of a BIND or REBIND subcommand. Both subcommands allow for the specification of the authorization ID of the owner of the plan or package.

BINDAGENT can specify an owner other than himself (or one of his representatives), but it has to be someone that granted him BINDAGENT. The default owner for BIND is the primary authorization ID. The default owner for REBIND is the previous owner of the plan or package (ownership is unchanged if an owner is not explicitly specified). If the BIND or REBIND is performed in a trusted context that is defined with the ROLE AS OBJECT OWNER clause, the owner of the plan or package is a role. If the OWNER bind option is specified, the role that is specified in it is the owner, otherwise the role that performs the bind or rebind becomes the owner.

The authorization ID that is used for the authorization checking of embedded SQL statements is that of the owner of the plan or package. If the application is bound in a trusted context using the ROLE AS OBJECT OWNER clause, the authorization ID that is used for authorization checking is the role that owns the plan or package, otherwise the authorization ID is the authorization ID of the owner of the plan or package. If an embedded SQL statement refers to tables or views at a Db2 subsystem other than the one at which the plan or package is bound, the authorization checking is deferred until run time. For more information on this, see [“Authorization IDs and remote execution” on page 96](#).

If VALIDATE(BIND) is specified, the privileges required to use or manipulate objects at the Db2 subsystem at which the plan or package is bound must exist at bind time. If the privileges or the referenced objects do not exist and SQLERROR(NOPACKAGE) is in effect, the bind operation is unsuccessful. If

SQLERROR(CONTINUE) is specified, then the bind is successful and any statements in error are flagged. If any statements in error are flagged, an error will occur when you attempt to execute them at run time.

If a plan or package is bound with VALIDATE(RUN), authorization checking is still performed at bind time, but the referenced objects and the privileges required to use these objects need not exist at this time. If any privilege required for a statement does not exist at bind time, an authorization check is performed whenever the statement is first executed within a unit of work, and all privileges required for the statement must exist at that time. If any privilege does not exist, execution of the statement is unsuccessful. When the authorization check is performed at run time, it is performed against the plan or package owner, not the SQL authorization ID. For the effect of this option on cursors, see [“DECLARE CURSOR statement” on page 1819](#).

Related tasks

[Binding application packages and plans \(Db2 Application programming and SQL\)](#)

Related reference

[BIND PACKAGE subcommand \(DSN\) \(Db2 Commands\)](#)

[BIND PLAN subcommand \(DSN\) \(Db2 Commands\)](#)

[REBIND PACKAGE subcommand \(DSN\) \(Db2 Commands\)](#)

[REBIND PLAN command \(DSN\) \(Db2 Commands\)](#)

Authorization IDs and dynamic SQL

The bind option DYNAMICRULES determines the authorization ID that is used for checking authorization when dynamic SQL statements are processed. The set of values for the authorization ID and other dynamic SQL attributes is called the *dynamic SQL statement behavior*. The four possible behaviors are run, bind, define, and invoke.

This discussion applies to dynamic SQL statements that refer to objects at the current server. For those that refer to objects elsewhere, see [“Authorization IDs and remote execution” on page 96](#).

In addition to determining the authorization ID, DYNAMICRULES also controls other dynamic SQL attributes such as the implicit qualifier that is used for unqualified alias, index, sequence, table, trigger, and view names; the source for application programming options; and whether certain SQL statements can be invoked dynamically.

As the following table shows, the combination of the value of the DYNAMICRULES option and the runtime environment determines which of the four dynamic SQL statement behaviors is used. DYNAMICRULES(RUN), which implies run behavior, is the default.

Table 14. How DYNAMICRULES and the runtime environment determine dynamic SQL statement behavior

DYNAMICRULES value	Behavior of dynamic SQL statements	
	Stand-alone program environment	User-defined function or stored procedure environment
RUN	Run	Run
BIND	Bind	Bind
DEFINERUN	Run	Define
DEFINEBIND	Bind	Define
INVOKERUN	Run	Invoke
INVOKEBIND	Bind	Invoke

Note: BIND and RUN values can be specified for packages, plans, and native SQL procedures. The other values can be specified for packages and native SQL procedures but not for plans.

In the following behavior descriptions, a package that *runs under* a user-defined function or stored procedure package is a package whose associated program meets one of the following conditions:

- The program is called by a user-defined function or stored procedure.
- The program is in a series of nested calls that start with a user-defined function or stored procedure.

Run behavior

Db2 uses the authorization IDs of the application process and the SQL authorization ID (the value of special register CURRENT SQLID) for authorization checking of dynamic SQL statements. If the process is running in a trusted context with a role associated with the primary authorization ID, the authorization IDs of the application process include this role.

A process that uses a plan and its associated packages is called an *application process*. At any time, the SQL authorization ID is the value of CURRENT SQLID. This SQL special register can be initialized by the connection or sign-on exit routine. If the exit routine does not set a value, the initial value of CURRENT SQLID is the primary authorization ID of the process. You can use the SQL statement SET CURRENT SQLID to change the value of CURRENT SQLID. Unless some authorization ID of the process has SYSADM authority, the new value must be one of the authorization IDs of the process. Thus, CURRENT SQLID usually contains either the primary authorization ID of the process or one of its secondary authorization IDs. The CURRENT SQLID cannot contain a role.

Privilege set

If the dynamically prepared statement is other than a CREATE, GRANT, or REVOKE statement, each privilege required for the statement can be a privilege designated by any authorization ID of the process. Therefore, the privilege set is the union of the set of privileges held by each authorization ID of the process. When the process is running in a trusted context with a role, the authorization IDs of the process include this role.

If the dynamic SQL statement is a CREATE, GRANT, or REVOKE statement, the only authorization ID that is used for authorization checking is the SQL authorization ID. Therefore, the privilege set is the privileges held by that single authorization ID of the process. If the process is running in a trusted context using the ROLE AS OBJECT OWNER clause for the a CREATE, GRANT, or REVOKE statement, the single authorization ID of the process that is checked is the role that is in effect.

Implicit qualification

When an SQL statement is dynamically prepared, the values of the CURRENT SCHEMA special register is used as the implicit qualifier. For example, it is used as the implicit qualifier for all unqualified tables, aliases, views, indexes, and sequences. For more information, see [“Unqualified object name resolution”](#) on page 86.

Bind behavior

The same rules that are used to determine the authorization ID for static (embedded) statements are used for dynamic statements. Db2 uses the authorization ID of the owner of the package or plan for authorization checking of dynamic SQL statements, as explained in [“Authorization IDs and statement preparation”](#) on page 93.

Privilege set

The privilege set is the privileges that are held by the owner of the package or plan.

Implicit qualification

The identifier specified in the QUALIFIER option of the bind command that is used to bind the SQL statements, or the CREATE PROCEDURE or ALTER PROCEDURE statement that is used to create a version of an SQL procedure is the implicit qualifier for all unqualified tables, views, aliases, indexes, and sequences. If the QUALIFIER option was not used when the plan, package, or native SQL procedure was created or last changed, the implicit qualifier is the owner of the plan, package, or native SQL procedure.

Define behavior

Define behavior applies only if the dynamic SQL statement is in a package that is run as a stored procedure or user-defined function (or *runs under* a stored procedure or user-defined function package), and the package was bound with DYNAMICRULES(DEFINEBIND) or DYNAMICRULES(DEFINERUN). Db2 uses the authorization ID of the stored procedure or user-defined function owner (the definer) for authorization checking of dynamic SQL statements in the application package.

Privilege set

The privilege set is the privileges that are held by the authorization ID of the owner.

Implicit qualification

The stored procedure or user-defined function owner is also the implicit qualifier. For example, the owner is the implicit qualifier for unqualified table, view, alias, index, and sequence names.

Invoke behavior

Invoke behavior applies only if the dynamic SQL statement is in a package that is run as a stored procedure or user-defined function (or *runs under* a stored procedure or user-defined function package), and the package was bound with DYNAMICRULES(INVOKEBIND) or DYNAMICRULES(INVOKERUN). Db2 uses the stored procedure or user-defined function invoker for authorization checking of dynamic SQL statements in the application package. The invoker can also be a role.

Privilege set

The privilege set is the privileges that are held by the invoker. However, if the invoker is the primary authorization ID of the process or the CURRENT SQLID value, secondary authorization IDs are also checked. This includes the role of the primary authorization ID, if running in a trusted context with a role. In that case, the privilege set is the union of the set of privileges held by each authorization ID of the process.

Implicit qualification

The stored procedure or user-defined function invoker is also the implicit qualifier. For example, it is the implicit qualifier for unqualified table, view, alias, index, and sequence names. The invoker can also be a role.

Restricted statements when run behavior does not apply

When bind, define, or invoke behavior is in effect, you cannot use the following dynamic SQL statements: ALTER, CREATE, COMMENT, DROP, GRANT, RENAME, and REVOKE.

Related concepts

[Dynamic rules options for dynamic SQL statements \(Db2 Application programming and SQL\)](#)

Related reference

[DYNAMICRULES bind option \(Db2 Commands\)](#)

[Privileges required for using dynamic SQL statements \(Managing Security\)](#)

Authorization IDs and remote execution

The authorization rules for remote execution depend on whether the distributed operation is DRDA access with a Db2 for z/OS server and requester. DRDA access with a server and requester other than Db2 can also effect the authorization rules for remote execution.

DRDA access with Db2 for z/OS only

To prepare and execute SQL statements using DRDA access, certain privileges are required by the package owner and additional privileges are required by the user who invokes the application.

Any static statement executed using DRDA access is in a package bound at a server other than the local Db2 subsystem. Before the package can be bound, its owner must have the BINDADD privilege and the CREATE IN privilege for the package's collection. Also required are enough privileges to execute the package's static SQL statements that refer to data on that server. All these privileges are recorded in the Db2 catalog of the server, not in the catalog of the local Db2 subsystem. Such privileges must be granted by GRANT statements executed at the server. This allows the server to control the creation and use of packages that are run from other DBMSs.

A user who invokes an application that has a plan at the local Db2 subsystem must have the EXECUTE privilege on the plan recorded in the Db2 catalog of the local subsystem. If that application uses a package that is bound at a Db2 server other than the local Db2 requester, the EXECUTE privilege on the package must also be recorded in the Db2 catalog of the server. The ID that must hold the authorization

to run the package at the Db2 server depends on the value of the PRIVATE_PROTOCOL subsystem parameter at the Db2 server:

- If PRIVATE_PROTOCOL is set to NO, EXECUTE authority on the package must be explicitly granted to the primary user ID or an associated secondary ID at the Db2 server. If the local requester application invokes a stored procedure that resides at the Db2 server, EXECUTE authority on the stored procedure package must be explicitly granted at the Db2 server to the owner of the package that issues the CALL statement if either of the following is true:
 - The owner of the stored procedure does not have the authority to execute the remote stored procedure package.
 - The CALL statement is in the form of CALL: host-variable and neither the primary user ID nor an associated secondary ID has the authority to execute the remote stored procedure package.
- If PRIVATE_PROTOCOL is not set to NO, EXECUTE authority on the package must be explicitly granted to the local requester plan owner at the Db2 server. The plan owner needs no other privilege to execute the package. If the local requester application invokes a stored procedure that resides at the Db2 server, EXECUTE authority on the stored procedure package must be explicitly granted at the Db2 server to the Db2 requester plan owner of the application that issues the CALL statement if either of the following is true:
 - The owner of the stored procedure does not have the authority to execute the remote stored procedure package.
 - The CALL statement is in the form of CALL: host-variable and neither the primary user ID nor an associated secondary ID has the authority to execute the remote stored procedure package.

EXECUTE authority is also required to use a package for a user-defined function, trigger, or stored procedure that resides at the Db2 server. However, except as previously described for a specific stored procedure case, the PRIVATE_PROTOCOL subsystem parameter is not used to determine the ID that is required to hold the EXECUTE privilege on that package. The EXECUTE privilege on that package must be recorded in the Db2 catalog of the server.

Having the appropriate privileges recorded as described above allows the execution of the static SQL statements in the package, and the execution of dynamic SQL statements if DYNAMICRULES bind, define, or invoke behavior is in effect. If DYNAMICRULES run behavior is in effect, the authorization rules for dynamic SQL statements is different. Authorization for the execution of dynamic SQL statements must come from the set of authorization IDs that are derived during connection processing, and, if the process is running in a trusted connection, the role that is in effect. An application goes through connection processing when it first connects to a server or when it reuses a CICS or IMS thread that has a different primary authorization ID.

If an application uses Recoverable Resources Manager Services attachment facility (RRSAF) and has no plan, authority to execute the package is determined in the same way as when the requester is not Db2 for z/OS.

Related concepts

[Managing connection requests from local applications \(Managing Security\)](#)

[DRDA access with a server or requester other than Db2](#)

Specific privileges are required depending on whether Db2 is the server or the requester involved in DRDA access.

Related tasks

[Checking authorization at a Db2 database server \(Managing Security\)](#)

DRDA access with a server or requester other than Db2

Specific privileges are required depending on whether Db2 is the server or the requester involved in DRDA access.

Db2 for z/OS as the server: If the requester is not a Db2 for z/OS subsystem, there is no Db2 application plan involved. In this case, the privilege set of the authorization ID, which is determined by the DYNAMICRULES behavior, must have the EXECUTE privilege on the package. Dynamic SQL statements in

the package are executed according to the DYNAMICRULES behavior, as described in [“Authorization IDs and dynamic SQL”](#) on page 94.

Db2 for z/OS as the requester: The authorization rules for remote execution are those of the server.

Authorization ID translations

When certain authorization IDs are sent to a remote DBMS, those authorization IDs might undergo translation before being used.

Translation can occur for a primary authorization ID, the authorization ID of the owner of an application plan, or the authorization ID of the owner of a package. For example, a user known as SMITH at the local DBMS could be known, after translation, as JONES at the server. Likewise, a package owner known as GRAY could be known as WINTERS at the server. If so, JONES or WINTERS would be used, instead of SMITH or GRAY, to determine the authorization ID for dynamic SQL statements in the package. If the DYNAMICRULES run behavior applies, JONES, who is executing the dynamic statement at the server, is used. If DYNAMICRULES bind behavior applies, WINTERS, the package owner at the server, is used.

Two sets of communications database (CDB) catalog tables control the translations. One set is at the local Db2, and the other set is at the remote Db2. Translation can take place at either or both sites.

Related concepts

[Communications database for the requester \(Managing Security\)](#)

[Communications database for the server \(Managing Security\)](#)

Other security measures

Even if Db2 authority requirements are satisfied, other security measures can be in effect when distributed data is accessed.

The fact that Db2 authority requirements are satisfied does not guarantee that a user has access to a given server. Other security measures can also come into play. For example, requests to execute remote SQL statements could be denied based on Resource Access Control Facility (RACF) considerations. Developing such security measures is discussed in [Getting started with Db2 security \(Managing Security\)](#) and [Introduction to the RACF access control module \(RACF Access Control Module Guide\)](#).

Data types

Db2 supports both IBM-supplied data types (built-in data types) and user-defined data types (distinct types).

The smallest unit of data that can be manipulated in SQL is called a *value*. How values are interpreted depends on the data type of their source. Values have the following sources:

- Columns
- Constants
- Expressions
- Functions
- Special registers
- Variables (such as host variables, SQL variables, global variables, parameter markers, and parameters of routines)

The following topics describes the built-in data types and distinct types.

[Figure 22 on page 99](#) shows the built-in data types that Db2 supports.

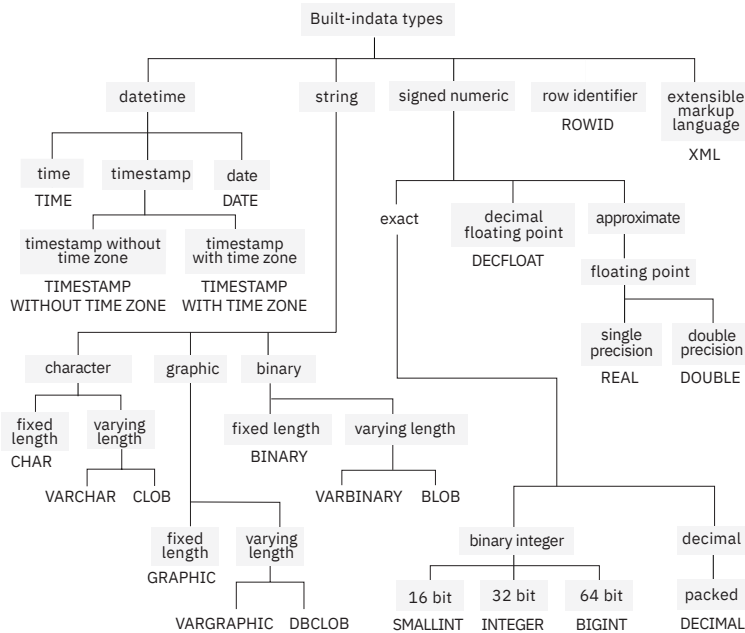

Figure 22. Built-in data types supported by Db2

NULLS

All data types include the null value. Distinct from all nonnull values, the null value is a special value that denotes the absence of a (nonnull) value.

Although all data types include the null value, some sources of values cannot provide the null value. For example, constants, columns that are defined as NOT NULL, and special registers cannot contain null values; the COUNT and COUNT_BIG functions cannot return a null value; and ROWID columns cannot store a null value although a null value can be returned for a ROWID column as the result of a query.

Related concepts

[Null values in table columns \(Introduction to Db2 for z/OS\)](#)

[When to use null or default values \(Introduction to Db2 for z/OS\)](#)

Related reference

[CREATE TABLE statement](#)

The CREATE TABLE statement defines a table. The definition must include its name and the names and attributes of its columns. The definition can include other attributes of the table, such as its primary key and its table space.

Numeric data types

The numeric data types are binary integer, decimal, decimal floating-point, and floating-point.

The numeric data types are categorized as follows:

- Exact numeric data types: binary integer and decimal
- Decimal floating-point
- Approximate numeric data types: floating-point

Binary integer includes small integer, large integer, and big integer. Binary numbers are exact representations of integers. Decimal numbers are exact representations of real numbers, with a fixed precision and scale. Binary and decimal numbers are considered exact numeric types.

Decimal floating-point includes DECFLOAT(16) and DECFLOAT(34), which are capable of representing either 16 or 34 significant digits. The decimal floating-point data type supports both exact representations of real numbers and approximations of real numbers, and is not considered to be either an exact numeric type or an approximate numeric type.

Floating-point includes single precision and double precision. Floating-point numbers are approximations of real numbers, and are considered to be approximate numeric types.

All numbers have a sign, a precision, and a scale. If a column value is zero, the sign is positive. Decimal floating point has distinct values for a number and the same number with various exponents (for example: 0.0, 0.00, 0.0E5, 1.0, 1.00, 1.0000). The precision is the total number of binary or decimal digits excluding the sign. The scale is the total number of binary or decimal digits to the right of the decimal point. If there is no decimal point, the scale is zero.

Small integer (SMALLINT)

A *small integer* is a binary integer with a precision of 15 bits.

The range of small integers is -32768 to +32767.

Large integer (INTEGER)

A *large integer* is a binary integer with a precision of 31 bits.

The range of large integers is -2147483648 to +2147483647.

Big integer (BIGINT)

A *big integer* is a binary integer with a precision of 63 bits.

The range of big integers is -9223372036854775808 to +9223372036854775807.

Single precision floating-point (REAL)

A *single precision floating-point* number is a short (32 bits) floating-point number.

The range of single precision floating-point numbers is about $-7.2E+75$ to $7.2E+75$. In this range, the largest negative value is about $-5.4E-79$, and the smallest positive value is about $5.4E-079$.

Double precision floating-point (DOUBLE or FLOAT)

A *double precision floating-point* number is a long (64 bits) floating-point number.

The range of double precision floating-point numbers is about $-7.2E+75$ to $7.2E+75$. In this range, the largest negative value is about $-5.4E-79$, and the smallest positive value is about $5.4E-079$.

Decimal (DECIMAL or NUMERIC)

A *decimal* number is a packed decimal number with an implicit decimal point.

The position of the decimal point is determined by the precision and the scale of the number. The scale, which is the number of digits in the fractional part of the number, cannot be negative or greater than the precision. The maximum precision is 31 digits.

All values of a decimal column have the same precision and scale. The range of a decimal variable or the numbers in a decimal column is $-n$ to $+n$, where n is the largest positive number that can be represented with the applicable precision and scale. The maximum range is $1 - 10^{31}$ to $10^{31} - 1$.

Decimal floating-point (DECFLOAT)

The maximum precision of a decimal floating-point number is 34 digits.

The range of a decimal floating point number is either 16 or 34 digits of precision, and an exponent range of respectively 10^{-383} to 10^{+384} or 10^{-6143} to 10^{+6144} .

In addition to the finite numbers, decimal floating point numbers are able to represent one of the following named special values:

- Infinity - a value that represents a number whose magnitude is infinitely large.
- Quiet NaN - a value that represents undefined results which does not cause an invalid number condition.
- Signaling NaN - a value that represents undefined results which will cause an invalid number condition if used in any numerical operation.

When a number has one of these special values, its coefficient and exponent are undefined. The sign of an infinity is significant (that is, it is possible to have both positive and negative infinity). The sign of a NaN has no meaning for arithmetic operations. INF can be used in place of INFINITY.

Subnormal numbers and underflow

The decimal floating-point data type has a set of non-zero numbers that fall outside the range of normal decimal floating-point values. These numbers are called subnormal.

Non-zero numbers whose adjusted exponents are less than E_{\min}^4 are called subnormal numbers. These subnormal numbers are accepted as operands for all operations and can result from any operation. If a result is subnormal before any rounding occurs, the subnormal condition is returned.

For a subnormal result, the minimum values of the exponent becomes $E_{\min} - (\text{precision} - 1)$, called E_{tiny} , where precision is the working precision. If necessary, the result will be rounded to ensure that the exponent is no smaller than E_{tiny} . If the result becomes inexact during rounding, an underflow condition is returned. A subnormal result does not always return the underflow condition but will always return the subnormal condition.

When a number underflows to zero during a calculation, its exponent will be E_{tiny} . The maximum value of the exponent is unaffected.

The maximum value of the exponent for subnormal numbers is the same as the minimum value of the exponent which can arise during operations that do not result in subnormal numbers. This occurs where the length of the coefficient in decimal digits is equal to the precision.

Numeric host variables

Numeric host variables can be defined in all languages with a few exceptions.

Binary integer variables can be defined in all host languages.

Floating-point variables can be defined in all host languages. All languages, except Java, support System/390 floating-point format. Assembler, C, C++, PL/I, and Java also support IEEE floating-point format. In assembler, C, C++, and PL/I programs, the SQL processing option FLOAT tells Db2 whether floating-point variables contain data in System/390 floating-point format or IEEE floating-point format. The contents of floating-point host variables must match the format that is specified with the FLOAT SQL processing option.

Decimal variables can be defined in all host languages except Fortran.

In COBOL, decimal numbers can be represented in the following formats:

- Packed decimal format, denoted by USAGE PACKED-DECIMAL or COMP-3
- External decimal format, denoted by USAGE DISPLAY with SIGN LEADING SEPARATE
- NATIONAL decimal format denoted by USAGE NATIONAL and SIGN LEADING SEPARATE

Decimal floating-point variables can be defined in Assembler, C, C++, PL/I, and Java.

String representations of numeric values

String representations of numeric values can be used in some contexts. A valid string representation of a numeric value must conform to the rules for numeric constants.

The encoding scheme in use determines the types of strings that can be used for string representation of numeric values. For ASCII and EBCDIC, a string representation of a numeric value must be a character string. For UNICODE, a string representation of a numeric value can be either a character string or a graphic string. Thus, the only time a graphic string can be used for a numeric value is when the encoding scheme is UNICODE.

When a decimal number is cast to a string (for example, using a CAST specification), the implicit decimal point is replaced by the default decimal separator character that is in effect when the statement is prepared.

When a string is cast to a decimal value (for example, using a CAST specification), the default decimal separator character in effect when the statement was prepared is used to interpret the string.

When a floating point or decimal floating-point number is cast to a string (for example, using a CAST specification), or a string is cast to a floating point or decimal floating-point number, the decimal separator character must be a period (.).

Related concepts

Constants

A *constant* (also called a *literal*) specifies a value. Constants are classified as null constants, string constants, numeric constants, or datetime constants. Numeric constants are further classified as integer, floating-point, decimal, or decimal floating-point. String constants are classified as character, graphic, or binary.

Numeric data types

The numeric data types are binary integer, decimal, decimal floating-point, and floating-point.

Arithmetic operators in expressions

If arithmetic operators are used, the result of the expression is a number derived from the application of the operators to the values of the operands.

Numeric host variables

Numeric host variables can be defined in all languages with a few exceptions.

Binary integer variables can be defined in all host languages.

Floating-point variables can be defined in all host languages. All languages, except Java, support System/390 floating-point format. Assembler, C, C++, PL/I, and Java also support IEEE floating-point format. In assembler, C, C++, and PL/I programs, the SQL processing option FLOAT tells Db2 whether floating-point variables contain data in System/390 floating-point format or IEEE floating-point format. The contents of floating-point host variables must match the format that is specified with the FLOAT SQL processing option.

Decimal variables can be defined in all host languages except Fortran.

In COBOL, decimal numbers can be represented in the following formats:

- Packed decimal format, denoted by USAGE PACKED-DECIMAL or COMP-3
- External decimal format, denoted by USAGE DISPLAY with SIGN LEADING SEPARATE
- NATIONAL decimal format denoted by USAGE NATIONAL and SIGN LEADING SEPARATE

Decimal floating-point variables can be defined in Assembler, C, C++, PL/I, and Java.

Character strings

A *character string* is a sequence of bytes. The length of the string is the number of bytes in the sequence. If the length is zero, the value is called the *empty string*. The empty string should not be confused with the null value.

Default CCSIDs for character strings

The value of the field MIXED DATA (on installation panel DSNTIPF) determines the default CCSIDs for a character string.

The following table shows how the value of the field MIXED DATA (on installation panel DSNTIPF) determines the default CCSIDs for a character string.

Table 15. Default CCSIDs for character strings

Encoding scheme	Value of MIXED DATA field	Default attribute
ASCII or EBCDIC	NO	Character: SBCS The value of the ASCII CCSID or EBCDIC CCSID field on installation panel determines the system CCSID for SBCS data.
ASCII or EBCDIC	YES	Character: MIXED The value of the ASCII CCSID or EBCDIC CCSID field on installation panel DSNTIPF determines the system CCSID for SBCS data, MIXED, and graphic data.
Unicode	Not applicable	Character: MIXED The CCSIDs are: <ul style="list-style-type: none"> • 367 for SBCS data • 1208 for MIXED data • 1200 for graphic data

The MIXED DATA field does not apply to Unicode columns in EBCDIC tables. Those columns follow the same rules that are shown for the Unicode encoding scheme in the previous table. For more information, see [“Unicode columns in EBCDIC tables”](#) on page 113.

Fixed-length character strings

When fixed-length character string distinct types, columns, and variables are defined, the length attribute is specified, and all values have the same length. For a fixed-length character string, the length attribute must be in the range 1–255 inclusive.

Varying-length character strings

The types of varying-length character strings are VARCHAR and character large object (CLOB). A CLOB is a type of LOB. A CLOB column is useful for storing large amounts of character data, such as documents written with a single character set.

When varying-length character strings, distinct types, columns, and variables are defined, the maximum length is specified and this length becomes the length attribute except for C NUL-terminated strings. Actual values might have a smaller value. For varying-length character strings, the length specifies the number of bytes.

For a VARCHAR string, the length attribute must be in the range 1 - 32704. For a VARCHAR column, the maximum for the length attribute is determined by the record size that is associated with the table, as described in [Maximum record size](#) the description of the CREATE TABLE statement. For a CLOB string, the length attribute must be in the range 1 - 2147483647 inclusive. For more information about CLOBs, see [“Large objects \(LOBs\)”](#) on page 116.

Character string variables

- Fixed-length character string variables can be used in all languages except REXX and Java. In C, CHAR string variables are limited to a length of 1.
- Varying-length character string variables can be used in all host languages with the following exceptions:
 - Fortran: varying-length non-LOB character strings cannot be used.
 - Assembler, C, and COBOL: varying-length non-LOB strings are simulated as described in *Db2 Application Programming and SQL Guide*. In C, NUL-terminated strings can also be used.
 - REXX: CLOBs and DBCLOBs cannot be used.

Character string encoding schemes

The method of representing DBCS and MBCS characters within a mixed string differs among the encoding schemes.

Each character string is further defined as one of the following subtypes:

Bit data

Data that is not associated with a coded character set and, therefore, is never converted. The CCSID for bit data is X'FFFF' (65535). The bytes do not represent characters.

Bit data is a form of character data. The pad character is a blank for assignments to bit data; the pad character is X'00' for assignments to binary data. It is recommended that binary data be used instead of character for bit data.

If both operands in a predicate are EBCDIC, both operands are padded with X'40'. Otherwise, both operands are padded with X'20'. For example, if both operands are ASCII, or if one operand is ASCII and the other operand is EBCDIC, both are padded with X'20'.

SBCS data

Data in which every character is represented by a single byte. Each SBCS string has an associated CCSID. If necessary, an SBCS string is converted before it is used in an operation with a character string that has a different CCSID.

Mixed data

Data that can contain a mixture of characters from a single-byte character set (SBCS) and a multiple-byte character set (MBCS). Each mixed string has an associated CCSID. If necessary, a mixed string is converted before an operation with a character string that has a different CCSID. If a mixed data string contains an MBCS character, it cannot be converted to SBCS data.

EBCDIC mixed data can contain shift characters, which are not MBCS data.

When the encoding scheme is Unicode or the Db2 installation is defined to support mixed data, Db2 recognizes MBCS sequences within mixed data string when performing character sensitive operations. These operations include parsing, character conversion, and the pattern matching specified by the LIKE predicate.

Character strings with a CLOB data type can only be SBCS or MIXED. BLOB should be used for binary strings.

The method of representing DBCS and MBCS characters within a mixed string differs among the encoding schemes.

- ASCII reserves a set of code points for SBCS characters and another set as the first half of DBCS characters. When it encounters the first half of a DBCS character, the system reads the next byte in order to obtain the complete character.
- EBCDIC makes use of two special code points:
 - A shift-out character (X'0E') to introduce a string of DBCS characters.

- A shift-in character (X'0F') to end a string of DBCS characters.

DBCS sequences within mixed data strings are recognized as the string is read from left to right. At any time, the reading of the string is in SBCS mode or DBCS mode. In SBCS mode, which is the initial mode, any byte other than a shift-out is interpreted as an SBCS character. When a shift-out is read, the mode switches to DBCS mode. In DBCS mode, the next byte and every second byte after that byte is interpreted as the first byte of a DBCS character unless it is a shift character. If the byte is a shift-out, an error occurs. If the byte is a shift-in, the mode returns to SBCS mode. An error occurs if the mode is still DBCS mode after processing the last byte of the string. Because of the shift characters, EBCDIC mixed data requires more storage than ASCII mixed data.

- UTF-8 is a varying-length encoding of byte sequences. The high bits indicate the part of the sequence to which a byte belongs. The first byte indicates the number of bytes to follow in a byte sequence.

Examples of character encoding schemes

The same mixed data character string can be represented as character and hexadecimal data in different encoding schemes.

For the same mixed data character string, the following table shows character and hexadecimal representations of the character string in different encoding schemes. In EBCDIC, the shift-out and shift-in characters are needed to delineate the double-byte characters.

Table 16. Example of a character string in different encoding schemes

Data type and encoding scheme	Character representation	Hexadecimal representation (with spaces separating each character)
9 bytes in ASCII	元 gen 氣,ki	8CB3 67 65 6E 8B43 6B 69
13 bytes in EBCDIC	0元 1 gen 0氣 1 ki	0E 4695 0F 87 85 95 0E 45B9 0F 92 89
11 bytes in Unicode UTF-8	元 gen 氣,ki	E58583 67 65 6E E6B097 6B 69

Because of the differences of the representation of mixed data strings in ASCII, EBCDIC, and Unicode, mixed data is not transparently portable. To minimize the effects of these differences, use varying-length strings in applications that require mixed data and operate on ASCII, EBCDIC, and Unicode data.

String units specifications

The ability to specify string units for certain built-in functions and on the CAST specification allows you to process string data in a more "character-based manner" than a "byte-based manner". The string unit determines the length in which the operation is to occur. For more information, see [“String unit specifications” on page 106](#).

Related concepts

[String unit specifications](#)

The ability to specify string units for certain built-in functions and on the CAST specification allows you to process string data in a more "character-based manner" than a "byte-based manner". The string unit determines the length in which the operation is to occur. You can specify CODEUNITS32, CODEUNITS16, or OCTETS as the units for the operation.

[Numeric data types](#)

The numeric data types are binary integer, decimal, decimal floating-point, and floating-point.

[Characters and tokens in SQL](#)

The most basic elements of SQL syntax are characters and tokens. Tokens are the basic syntactical units of the SQL language.

String unit specifications

The ability to specify string units for certain built-in functions and on the CAST specification allows you to process string data in a more "character-based manner" than a "byte-based manner". The string unit determines the length in which the operation is to occur. You can specify CODEUNITS32, CODEUNITS16, or OCTETS as the units for the operation.

CODEUNITS32

Specifies that Unicode UTF-32 is the units for the operation. CODEUNITS32 is useful when an application wants to process data in a simple fixed-length format and needs the same answer regardless of the storage format of the data (ASCII, EBCDIC, UTF-8, or UTF-16). Although the answers are in terms of CODEUNITS32, the data is not converted to UTF-32 to perform the function.

CODEUNITS16

Specifies that Unicode UTF-16 is the units for the operation. CODEUNITS16 is useful when an application wants to know how many double-byte characters are in a string.

OCTETS

Specifies that bytes are the units for the operation. OCTETS is often used when an application is interested in allocation buffer space or when operations need to use simple byte processing.

Determining the length of a string by counting in string units (CODEUNITS16 or CODEUNITS32) or bytes (OCTETS) can result in different answers. When OCTETS is specified, the length of a string is determined by simply counting the number of bytes in the string. Counting by CODEUNITS16 or CODEUNITS32 gives the same answer unless the data contains supplementary characters. For information about the difference between CODEUNITS16 and CODEUNITS32 when the data contains supplementary characters, see [“Difference between CODEUNITS16 and CODEUNITS32” on page 107](#).

Example: Assume that NAME is a VARCHAR(128) column, encoded in Unicode UTF-8, that contains the value 'Jürgen'. The first two queries, which count the length of the string in CODEUNITS32 and CODEUNITS16, returns the same value, 6. The third query, which counts the length of the string in OCTETS, returns the value 7. These values are the length of the string as expressed in the string units that are specified.

```
SELECT CHARACTER_LENGTH(NAME, CODEUNITS32)
FROM T1 WHERE NAME = 'Jürgen';
```

```
SELECT CHARACTER_LENGTH(NAME, CODEUNITS16)
FROM T1 WHERE NAME = 'Jürgen';
```

```
SELECT CHARACTER_LENGTH(NAME, OCTETS)
FROM T1 WHERE NAME = 'Jürgen';
```

The following table shows the UTF-8, UTF-16, and UTF-32 representations of 'Jürgen'.

Format	Representation of the name 'Jürgen'
UTF-8	x'4A C3BC 7267656E'
UTF-16	x'004A 00FC 007200670065006E'
UTF-32	x'0000004A 000000FC 0000007200000067000000650000006E'

The bold highlighting in the table demonstrates how the representation of the character ü in 'Jürgen' differs between the three string units:

- The UTF-8 representation of the character ü is X'C3BC'. In UTF-8, characters that are not in the Latin-1 subset (essentially a through z, A through Z, and 0 through 9), such as accented characters or Japanese characters, are represented by multiple bytes.

- The UTF-16 representation of the character ü is X'00FC'. In UTF-16, each character is represented in 2 bytes. UTF-16 supplementary characters take two 2-byte code points.
- The UTF-32 representation of the character ü is X'00000FC'. In UTF-32, each character is represented in 4 bytes.

Specifying the string units on a built-in function does not affect the data type or the CCSID of the result of the function. If necessary, Db2 converts the data to Unicode for evaluation when CODEUNITS32 or CODEUNITS16 is specified. Db2 always evaluates the data in the encoding scheme of the output data when OCTETS is specified. For more information about the data types and CCSIDs of the results of functions, see the description of each function.

Differences between the way that characters are represented in ASCII, EBCDIC, and Unicode can affect the results of your queries.

Example: Assume that NAME is a VARCHAR(128) column, encoded in EBCDIC (CCSID 37), that contains the value 'Mit freundlichen Grüßen, Jürgen'. The following query returns the string 'Mit freundlichen Grüß':

```
SELECT SUBSTRING(C1,1,21,CODEUNITS16)
FROM T1 WHERE C1 = 'Mit freundlichen Grüßen, Jürgen';
```

The following table shows the result data in more detail:

Format	Representation of 'Mit freundlichen Grüß'
EBCDIC	D489A340869985A4958493898388859540C799 DC59
UTF-8	4D697420667265756E646C696368656E204772 C3BCC39F
UTF-16	004D0069007400200066007200650075006E0064006C00690063006800 065006E002000470072 00FC00DF

The bold highlighting in the table shows that the representation of the characters ü and ß in UTF-8 and UTF-16 each require two bytes. If OCTETS had been specified on the SUBSTRING function to have the string evaluated in UTF-8 bytes instead of EBCDIC OCTETS or CODEUNITS16, the result would have been 'Mit freundlichen Grü'. The character ß would have been lost.

Related concepts

Character strings

A *character string* is a sequence of bytes. The length of the string is the number of bytes in the sequence. If the length is zero, the value is called the *empty string*. The empty string should not be confused with the null value.

Difference between CODEUNITS16 and CODEUNITS32

CODEUNITS16 and CODEUNITS32 return the same answer unless the data contains supplementary characters.

A supplementary character is represented as two UTF-16 code units or one UTF-32 code unit. In UTF-8, a non-supplementary character is represented by 1 to 3 bytes and a supplementary character is represented by 4 bytes. In UTF-16, a non-supplementary character is represented by one CODEUNIT16 code unit or 2 bytes, and a supplementary character is represented by two CODEUNIT16 code units or 4 bytes. In UTF-32, a character is represented by one CODEUNIT32 code unit or 4 bytes. Thus, CODEUNITS16 and CODEUNITS32 return different answers when the data contains supplementary characters.

Example 1: The following table shows the hexadecimal values for the mathematical bold capital A and the Latin capital letter A. The mathematical bold capital A is a supplementary character that is represented by 4 bytes in UTF-8, UTF-16, and UTF-32.

Character	UTF-8 representation	UTF-16 representation	UTF-32 representation
Unicode value \u1D400 - 'A' MATHEMATICAL BOLD CAPITAL A	X'F09D9080'	X'D835DC00'	X'0001D400'
Unicode value \u0041 - 'A' LATIN CAPITAL LETTER A	X'41'	X'0041'	X'00000041'

Assume that C1 is a VARCHAR(128) column, encoded in Unicode UTF-8, and that table T1 contains one row with the value of the mathematical bold capital A (X'F09D9080'). The following similar queries return different answers:

```
-- Query:                                -- Returns the value:
SELECT CHARACTER_LENGTH(C1, CODEUNITS32) FROM T1;      -- 1
SELECT CHARACTER_LENGTH(C1, CODEUNITS16) FROM T1;     -- 2
SELECT CHARACTER_LENGTH(C1, OCTETS) FROM T1;          -- 4
```

Example 2: Assume that C1 is a VARCHAR(128) column, encoded in Unicode UTF-8, and that table T1 contains one row with the value of the mathematical bold capital A (X'F09D9080'). The following similar queries return different answers.

```
-- Query:                                -- Returns the value:
SELECT HEX(SUBSTRING(C1,1,1, CODEUNITS32)) FROM T1;   -- X'F09D9080'
SELECT HEX(SUBSTRING(C1,1,1, CODEUNITS16)) FROM T1;  -- X'20'
SELECT HEX(SUBSTRING(C1,1,2, CODEUNITS16)) FROM T1;  -- X'F09D9080'
SELECT HEX(SUBSTRING(C1,1,1, OCTETS)) FROM T1;       -- X'20'
SELECT HEX(SUBSTR(C1,1,1)) FROM T1;                  -- X'F0'
```

The value X'20' is the pad (blank) character.

Determining the length attribute of the final result

When CODEUNITS32, CODEUNITS16, or OCTETS is specified for a function or the CAST specification, the length attribute of the final result string is calculated by applying specific formulas depending on which function is specified.

To determine the final result of a function or the CAST specification, Db2 might need to use an intermediate result string if CODEUNITS32 or CODEUNITS16 is specified, depending on the encoding scheme of the data:

- ASCII and EBCDIC data require the use of a UTF-16 intermediate result string when either CODEUNITS32 or CODEUNITS16 is specified.
- UTF-8 data requires the use of a UTF-16 intermediate result string only when CODEUNITS16 is specified.

Regardless of whether an intermediate string is used, when CODEUNITS32, CODEUNITS16, or OCTETS is specified for a function or the CAST specification, the length attribute of the final result string is calculated by applying the formulas that are described in the following table. The length attributes that are calculated at each step in the formulas are measured in bytes, unless indicated otherwise.

Determining the length attribute of the string

The formulas for the length attribute of the final result string depend on the function.

The final value of the calculation for each length attribute (IML, rl, and the final result of the function) is limited by the maximum length of the function or by the maximum length of the corresponding data type of the result, whichever is applicable. Each length attribute is expressed in terms of bytes.

CAST specification, CHAR, CLOB, DBCLOB, GRAPHIC, VARCHAR, VARGRAPHIC

Follow these three steps to determine the length attribute of the final result:

1. Length of the intermediate string (IML)

When CODEUNITS32 or CODEUNITS16 is specified:

- If the source string is not in Unicode CCSID 1200, 1208, or 367, convert the source string to CCSID 1200, using the formulas in [“Conversion rules for comparisons” on page 159](#) to determine the result length of the intermediate string (IML).
- If source string is in Unicode CCSID 1208 or 367, and CODEUNITS16 is specified, convert the source string to CCSID 1200, using the formulas in [“Conversion rules for comparisons” on page 159](#) to determine the result length of the intermediate string (IML).
- Otherwise, the intermediate string is the same as the source string.

When OCTETS is specified:

- If the CCSID of the source string is different from the CCSID of the result of the function, convert the source string to the CCSID of the result of the function, using the formulas in [“Conversion rules for comparisons” on page 159](#) to determine the result length of the intermediate string (IML).
- Otherwise, the intermediate string is the same as the source string.

Exception: For the GRAPHIC and VARGRAPHIC function, if the source string is EBCDIC, the source is widened with prefix X'42' before the source string is converted to CCSID 1200 and the length of the intermediate string is determined.

2. Result length attribute of the intermediate string (rl)

The result length (rl) of the intermediate string depends on whether a *length* argument was explicitly specified.

If *length* was not specified, the result length (rl) attribute is:

```
rl = IML
```

If *length* was specified, the result length (rl) attribute is:

```
IF (ol * n) < r_IML THEN
  rl = ol * n
ELSE
  IF intermediate string is in CCSID 1200
    (UTF-16) THEN
    rl = MIN( ol * n , IML + ( r * 2 ) )
  ELSE
    rl = MIN( ol * n , IML + r )
```

Where:

- ol = original *length* argument, expressed in the specified string units

n =

4 bytes for CODEUNITS32

2 bytes for CODEUNITS16

- IML = length of the intermediate string
- r_IML = IML rounded up to next multiple of n
- r = ol - (r_IML/n), expressed in the specified string units

The calculation for r is an estimate of the difference between the *length* argument and the estimated number of characters of the input argument, expressed in the specified string units.

3. Length of the final result string (the result of the function)

The result length attribute of the final string is determined by converting the result length (rl) of the intermediate string to the CCSID of the result of the function, using the formulas in [“Conversion rules for comparisons” on page 159](#), if CCSID conversion is necessary. Otherwise, the result length attribute of the final string is rl.

CHARACTER_LENGTH, LOCATE, LOCATE_IN_STRING, POSITION

Follow these three steps to determine the length attribute of the final result:

1. Length of the intermediate string (IML)

The length of the intermediate string (IML) is determined the same way as for the CAST specification. (See [Length of the intermediate string \(IML\)](#).)

For the LOCATE, LOCATE_IN_STRING, and POSITION functions, this applies to both the *source-string* and *search-string*. If the CCSIDs of intermediate strings for the converted *source-string* and *search-string* differ, the intermediate string for the *search-string* is converted to the CCSID of intermediate string for the *source-string*.

2. Result length attribute of the intermediate string (rl)

The result length (rl) attribute is always 4 (the length of an integer):

```
rl = 4
```

3. Length of the final result string (the result the function)

The length of the final result of the function is always an integer.

INSERT, OVERLAY

Follow these three steps to determine the length attribute of the final result:

1. Length of the intermediate string (IML)

The length of the intermediate string (IML) for both the *source-string* and the *insert-string* is determined the same way as for the CAST specification. (See [Length of the intermediate string \(IML\)](#).)

If the CCSIDs of the intermediate strings for the converted *source-string* and *insert-string* differ, the intermediate string for the *insert-string* is converted to the CCSID of the intermediate string for the *source-string*.

2. Result length attribute of the intermediate string (rl)

The result length (rl) attribute of the intermediate string depends on whether the start and length arguments are constants.

If the *start* and *length* arguments are both constants, the result length attribute is:

```
rl = L1 - MIN ( MAX ( 0, L1 - (V2 - 1) * n ), V3 * m) + L4
```

If at least one argument (the *start* or *length* argument) is not a constant, the result length attribute is:

```
rl = L1 + L4
```

Where:

- L1 and L4 are the length attributes of the intermediate strings of the *source-string* and *insert-string*, respectively.
- V2 and V3 are the *start* and *length* values, respectively, expressed in the specified string units.

m=

- 1 if the intermediate string of the *source-string* is not CCSID 1200 (UTF-16)
- 2 if the intermediate string of the *source-string* is CCSID 1200 (UTF-16)

n=

- 4 bytes for CODEUNITS32
- 2 bytes for CODEUNITS16

3. Length of the final result string (the result the function)

The length of the final result is the same as the length of the final result for the CAST specification. (See [Length attribute of the final result string \(the result of the function\)](#).)

LEFT, RIGHT

Follow these three steps to determine the length attribute of the final result:

1. Length of the intermediate string (IML)

The length of the intermediate string (IML) is determined the same way as for the CAST specification. (See [Length of the intermediate string \(IML\)](#).)

2. Result length attribute of the intermediate string (rl)

The result length (rl) attribute is the same as the length of the intermediate string:

```
rl = IML
```

3. Length of the final result string (the result of the function)

The result length attribute of the final string is determined by converting the result length (rl) of the intermediate string to the CCSID of the result of the function, using the formulas in “[Conversion rules for comparisons](#)” on page 159, if CCSID conversion is necessary. Otherwise, the result length attribute of the final string is rl.

The result length attribute of the final string is:

```
MIN(length of source string, length of CCSID  
converted string )
```

SUBSTRING

Follow these three steps to determine the length attribute of the final result:

1. Length of the intermediate string (IML)

The length of the intermediate string (IML) is determined the same way as for the CAST specification. (See [Length of the intermediate string \(IML\)](#).)

2. Result length attribute of the intermediate string (rl)

The result length (rl) of the intermediate string depends on whether a *length* argument was explicitly specified.

If *length* was not specified, the result length (rl) attribute is:

```
rl = IML
```

If *length* was specified, the result length (rl) attribute is:

```
rl = MIN(ol * n, IML)
```

Where:

- ol = original *length* argument, expressed in the specified string units

n =

4 bytes for CODEUNITS32

2 bytes for CODEUNITS16

- IML = length of the intermediate string

3. Length of the final result string (the result of the function)

The length of the final result string is the same as for LEFT built-in function.

Examples

Example 1

Assume that T1 is a table encoded in EBCDIC and C1 is a CHAR(26) column (SBCS data with EBCDIC CCSID 37). The CHAR function is invoked in the following statement:

```
SELECT CHAR(C1,10,CODEUNITS32) as COL1 FROM T1;
```

Db2 uses an intermediate string to evaluate the function and determines the intermediate and final result string lengths using these steps:

1. C1, which is SBCS EBCDIC 37 data, is converted to Unicode 1200 (UTF-16). The result length of the conversion (using the formula from “Conversion rules for comparisons” on page 159, $X * 2$) is $26 * 2$. Thus, the length of the intermediate string is 52 bytes (IML = 52).
2. The CHAR function is evaluated against the first 10 UTF-32 characters in this string. The result length attribute is 40 bytes ($r1 = o1 * n$ or $10 * 4$) because $o1 * n < r_IML$ or $40 < 52$.
3. The 40 bytes of the string are converted back to SBCS EBCDIC 37. The result length of the conversion (using the formula from “Conversion rules for comparisons” on page 159, $X * .5$) is $40 * .5$. Thus, the length of the final result of the functions is 20 bytes.

Example 2

This example is similar to the first example, except that the specified length for the function is 20 instead of 10. Assume that T1 is a table encoded in EBCDIC and C1 is a CHAR(26) column (SBCS data with EBCDIC CCSID 37). The CHAR function is invoked in the following statement:

```
SELECT CHAR(C1,20,CODEUNITS32) as COL1 FROM T1;
```

Db2 uses an intermediate string to evaluate the function and determines the intermediate and final result string lengths using these steps:

1. C1, which is SBCS EBCDIC 37 data, is converted to Unicode 1200 (UTF-16). The result length of the conversion (using the formula from “Conversion rules for comparisons” on page 159, $X * 2$) is $26 * 2$. Thus, the length of the intermediate result string is 52 bytes (IML = 52).
2. The CHAR function is evaluated against the first 20 UTF-32 characters in this intermediate string. However, because the estimated number of characters in the intermediate string, as expressed in the specified string units, is only 13 characters (r_IML/n or $52/4$), the intermediate string must be padded with 7 padding characters to satisfy the 20 characters that are requested ($r = o1 - (r_IML/n)$ or $20 - 13$). In Unicode 1200 (UTF-16), each padding character takes 2 bytes. The result length attribute is then calculated to be 66 bytes ($r1 = \text{MIN}(o1 * n, \text{IML} + (r * 2))$ or $\text{MIN}(20 * 4, 52 + 14)$) because $o1 * n < r_IML$ or $80 < 52$ is not true.
3. The 66 bytes of the string are converted back to SBCS EBCDIC 37. The result length of the conversion (using the formula from “Conversion rules for comparisons” on page 159, $X * .5$) is $66 * .5$. Thus, the length of the final result of the function is 33 bytes.

Graphic strings

A *graphic string* is a sequence of double-byte characters.

The length of the string is the number of characters in the sequence. Like character strings, graphic strings can be empty. An empty string should not be confused with the null value.

Fixed-length graphic strings

When fixed-length graphic string distinct types, columns, and variables are defined, the length attribute is specified and all values have the same length. For a fixed-length graphic string, the length attribute must be in the range 1–127 inclusive. A fixed-length graphic string column can also be called a GRAPHIC column.

Varying-length graphic strings

The types of varying-length graphic strings are VARGRAPHIC and *double-byte character large object* (DBCLOB). DBCLOB is a type of LOB. A DBCLOB column is useful for storing large amounts of double-byte character data, such as documents written with a single double-byte character set.

When varying-length graphic strings, distinct types, columns, and variables are defined, the maximum length is specified and this length becomes the length attribute. Actual values might have a smaller value. For a varying-length graphic string, the length attribute must be between 1 and 16352.

For a varying-length graphic string column, the maximum for the length attribute is determined by the record size associated with the table, as described [Maximum record size](#) in the description of the CREATE TABLE statement. For a DBCLOB string, the length attribute must be in the range 1–1 073 741 823 inclusive. In UTF-16, although supplementary characters use two 2-byte code points, supplementary characters are still considered double-byte characters. For more information about DBCLOBs, see [“Large objects \(LOBs\)”](#) on page 116.

Graphic string variables

Variables with a graphic string type cannot be defined in Fortran. Also, graphic string variables must follow these rules:

- Fixed-length graphic string host variables can be defined in all host languages, except REXX and Java. In C, fixed-length graphic-string variables are limited to a length of 1.
- Varying-length graphic string variables can be defined in all host languages, with the exception of DBCLOBs which cannot be used in REXX.

Graphic string encoding schemes

Each graphic string can be further defined as either double-byte data or Unicode data.

Double-byte data

Data in which every character is represented by a character from the double-byte character set (DBCS) that does not include shift-out or shift-in characters. Each double-byte graphic string has an associated ASCII or EBCDIC CCSID.

Unicode data

Data that contains characters represented by two bytes, except supplementary characters, which take two 2-byte code points per character. Each Unicode graphic string is encoded using UTF-16. The CCSID for UTF-16 is 1200.

String units in built-in functions

When working with graphic strings, you can specify the string unit in which the operation is to take place for certain built-in functions and the CAST specification. The string unit determines the length in which the operation is to occur.

For more information about string units, see [“String unit specifications”](#) on page 106.

Related concepts

[“Unicode columns in EBCDIC tables”](#) on page 113

A single encoding scheme is used for all character and character string data in a table. An exception is that an EBCDIC table can contain one or more Unicode columns in addition to EBCDIC string columns.

Unicode columns in EBCDIC tables

A single encoding scheme is used for all character and character string data in a table. An exception is that an EBCDIC table can contain one or more Unicode columns in addition to EBCDIC string columns.

An EBCDIC table can contain the following two types of Unicode columns:

Db2 12 or later Unicode columns

A Unicode column for character string data that was created in Db2 12 or later. The column is encoded in CCSID 1208 (UTF-8) or CCSID 1200 (UTF-16). Db2 12 or later Unicode columns are subject to fewer restrictions than Db2 11 Unicode columns.

Db2 11 Unicode columns

A Unicode column for character string data that was created in Db2 11. The column is encoded in CCSID 1208 (UTF-8).

Restrictions on Db2 11 Unicode columns in EBCDIC tables

Db2 11 Unicode columns in EBCDIC tables must satisfy the following criteria:

- The column must not be in the *column-name* list of a *unique-constraint* in a CREATE TABLE or ALTER TABLE statement.
- The column must not be in the *column-name* list of a *referential-constraint* in a CREATE TABLE or ALTER TABLE statement.
- The column must not be in the *column-name* list of a *references-clause* in a CREATE TABLE or ALTER TABLE statement.
- The column must not be in the *column-name* list of an ORGANIZE BY HASH clause in a CREATE TABLE or ALTER TABLE statement.
- The column must not be referenced in the CHECK(*check-condition*) clause in a CREATE TABLE or ALTER TABLE statement.
- The column must not be referenced in the CHECK(*check-condition*) clause in a CREATE TABLE or ALTER TABLE statement.
- The column can be the target of an ALTER COLUMN *column-alteration* clause in an ALTER TABLE statement only if the column is altered to the same data type, length, and CCSID. This change migrates a Db2 11 Unicode column to a Db2 12 Unicode column.
- In a *default-clause* in a CREATE TABLE or ALTER TABLE statement, a value cannot follow the DEFAULT keyword.
- The column cannot be used for *column-name* in a PARTITION BY RANGE clause in a CREATE TABLE or ALTER TABLE statement.
- The column cannot be altered.
- The column must not be referenced in a *join-condition* of a full outer join.
- In a CREATE TABLE or ALTER TABLE statement, the column definition must not contain a FIELDPROC clause.

Restrictions on EBCDIC tables with Db2 11 Unicode columns

An EBCDIC table that contains Db2 11 Unicode columns must satisfy the following criteria:

- The table name cannot be the *table-name* value in the LIKE clause of a CREATE TABLE statement.
- In an *as-result-table* clause in a CREATE TABLE statement, if the *from-clause* in the *fullselect* is an EBCDIC table that contains Db2 11 Unicode columns, the outermost SELECT list of the *fullselect* cannot contain a mixture of EBCDIC columns and Db2 11 Unicode columns.
- In a *materialized-query-definition* clause in a CREATE TABLE or ALTER TABLE statement, when ENABLE QUERY OPTIMIZATION is in effect, if the *from-clause* in the *fullselect* is an EBCDIC table that contains Db2 11 Unicode columns, the outermost SELECT list of the *fullselect* cannot contain a mixture of EBCDIC columns and Db2 11 Unicode columns.
- The EDITPROC clause must not be specified in the CREATE TABLE statement.
- The VALIDPROC clause must not be specified in the CREATE TABLE or ALTER TABLE statement.

Restriction on a created temporary table

When the LIKE clause is used to create a created temporary table, the table or view on which the created temporary table is based cannot be an EBCDIC table with a Db2 11 Unicode column.

Restriction on a declared temporary table

When the LIKE clause is used to create a declared temporary table, the table or view on which the declared temporary table is based cannot be an EBCDIC table with a Db2 11 Unicode column.

Restrictions on an index that has an index key with Db2 11 Unicode columns

- A CREATE INDEX statement must not specify DESC, PADDED, or RANDOM for a Db2 11 Unicode column in an EBCDIC table.
- An index that is defined on an EBCDIC table and is not an expression-based index must not include Db2 11 Unicode columns and Db2 12 Unicode columns. However, an expression-based index that is defined on an EBCDIC table can include Db2 11 Unicode columns and Db2 12 Unicode columns.

Restrictions on a table space that contains an EBCDIC table with Db2 11 Unicode columns

The CCSID of a table space that contains EBCDIC table with Db2 11 Unicode columns cannot be changed.

How the SQDA representnts Db2 11 Unicode columns are represented in EBCDIC tables

In an SQLVAR of an SQLDA after DESCRIBE or PREPARE INTO, Db2 11 Unicode columns in EBCDIC tables have these characteristics:

- For a column that is defined with CCSID 1208, the SQLTYPE field reflects VARCHAR and the SQLDATA field contains 1208, even though the column might be recorded in the catalog as VARBINARY with CCSID 1208.
- For a column that is defined with CCSID 1200, the SQLTYPE field reflects VARGRAPHIC and the SQLDATA field contains 1200, even though the column might be recorded in the catalog as VARBINARY with CCSID 1200.

Migrating Db2 11 Unicode columns in EBCDIC tables to Db2 12 or later Unicode columns in EBCDIC tables

Db2 11 Unicode columns in EBCDIC tables can be used with Db2 12, subject to the restrictions that exist in Db2. However, Db2 12 or later Unicode columns in EBCDIC tables have enhanced support, so you might want to convert Db2 11 Unicode columns to Db2 12 or later Unicode columns.

Procedure

To migrate Db2 11 Unicode columns in EBCDIC tables to Db2 12 or later Unicode columns columns, complete the following steps:

1. Run job DSNTIJPM. (You can run it before or after activating function level 500 in Db2 12. One of the reports that DSNTIJPM produces lists Db2 11 Unicode columns, the EBCDIC tables that contain them, and the indexes that are defined on the Db2 11 Unicode columns.
2. After Db2 12 function level 500 is activated, take one of the following actions:
 - Issue ALTER TABLE ALTER COLUMN to alter the Unicode column.
 - Issue ALTER TABLE DROP COLUMN and ALTER TABLE ADD COLUMN to drop and add the Unicode column.
 - Issue DROP TABLE AND CREATE TABLE to drop and recreate the table with the Unicode column.
3. Repopulate the column or table.

Related tasks

[Run premigration queries \(DSNTIJPM\) \(Db2 Installation and Migration\)](#)

Binary strings

A *binary string* is a sequence of bytes.

The length of a binary string is the number of bytes in the sequence. Binary strings are not associated with any CCSID. There are three binary string data types: BINARY, VARBINARY (BINARY VARYING) and BLOB (BINARY LARGE OBJECT).

Fixed-length binary strings

The type of fixed-length binary strings is BINARY. When fixed-length binary string distinct types, columns, and variables are defined, the length attribute is specified, and all values have the same length. For a fixed-length binary string, the length attribute must be in the range 1–255 inclusive.

Varying-length binary strings

The types of varying-length binary strings are VARBINARY (BINARY VARYING) and BLOB (BINARY LARGE OBJECT)

When varying-length binary strings, distinct types, columns, and variables are defined, the maximum length is specified and this length becomes the length attribute. Actual length values might have a smaller value than the length attribute value. For varying-length binary strings, the actual length specifies the number of bytes in the string.

For a VARBINARY string, the length attribute must be between 1 and 32704. For a VARBINARY string column, the maximum for the length attribute is determined by the record size that is associated with the table, as described in "Maximum record size" on the description of the CREATE TABLE statement. Like a varying-length character string, varying-length binary string could be an empty string.

A binary string column is useful for storing non-character data, such as encoded or compressed data, pictures, voice, and mixed media. Another use is to hold structured data for exploitation by distinct types, user-defined functions, and stored procedures. Note, that although binary strings and FOR BIT DATA character strings might be used for similar purposes, the two data types are not compatible. The BINARY, BLOB, VARBINARY built-in functions and CAST specification can be used to change a FOR BIT DATA character string into a binary string.

Large objects (LOBs)

The term *large object (LOB)* refers to any of the following data types: CLOB, DBCLOB, or BLOB.

CLOB

A *character large object (CLOB)* is a varying-length string with a maximum length of 2,147,483,647 bytes (2 gigabytes minus 1 byte). A CLOB is designed to store large SBCS data or mixed data, such as lengthy documents. For example, you can store information such as an employee resume, the script of a play, or the text of novel in a CLOB. Alternatively, you can store such information in UTF-8 in a mixed CLOB. A CLOB is a varying-length character string.

DBCLOB

A *double-byte character large object (DBCLOB)* is a varying-length string with a maximum length of 1,073,741,823 double-byte characters. A DBCLOB is designed to store large DBCS data. For example, you could store the information mentioned for CLOB (an employee resume, the script for a play, or the text of a novel) in UTF-16 in a DBCLOB. A DBCLOB is a varying-length graphic string.

BLOB

A *binary large object (BLOB)* is a varying-length string with a maximum length of 2,147,483,647 bytes (2 gigabytes minus 1 byte). A BLOB is designed to store non-traditional data such as pictures, voice, and mixed media. BLOBs can also store structured data for use by distinct types and user-defined functions. A BLOB is a binary string.

Although BLOB strings and FOR BIT DATA character strings might be used for similar purposes, the two data types are not compatible. The BLOB function can be used to change a FOR BIT DATA character string into a BLOB string.

Related concepts

[LOB table space implicit creation \(Db2 Administration Guide\)](#)

Related tasks

[Creating large objects \(Introduction to Db2 for z/OS\)](#)

[Storing LOB data in Db2 tables \(Db2 Application programming and SQL\)](#)

Related reference

[CREATE AUXILIARY TABLE statement](#)

The CREATE AUXILIARY TABLE statement creates an auxiliary table at the current server for storing LOB data.

[CREATE LOB TABLESPACE](#)

The CREATE LOB TABLESPACE statement defines a large object (LOB) table space at the current server. If your data for a table does not fit entirely within a data page, you can define one or more columns as LOB columns. Each LOB column must have an associated auxiliary table in a LOB table space. If the table space for the base table is partitioned, an associated auxiliary table in a LOB table space is required for each LOB column, for each partition of the table space for the base table.

Restrictions using LOBs

With a few exceptions, you can use LOBs in the same contexts in which you can use other varying-length strings.

The following table shows the contexts in which LOBs cannot be used.

Table 17. Contexts in which LOBs cannot be used

Context of usage	LOB (CLOB, DBCLOB, or BLOB)
A GROUP BY clause	Not allowed
An ORDER BY clause	Not allowed
A CREATE INDEX statement that creates an index using an expression	Not allowed except when the index is created using an expression, in which case an inline LOB column can be referenced as the source data type for the SUBSTR and SUBSTRING built-in functions.
A SELECT DISTINCT statement	Not allowed
A MERGE statement	Cannot be used in the context of an INCLUDE <i>column-name</i> clause
A subselect of a set operation except UNION ALL	Not allowed
Predicates	Cannot be used in any predicate except EXISTS, LIKE, and NULL. This restriction includes a <i>simple-when-clause</i> in a CASE expression. <i>expression</i> WHEN <i>expression</i> in a <i>simple-when-clause</i> is equivalent to a predicate with <i>expression=expression</i> .
The definition of primary, unique, and foreign keys	Not allowed
Check constraints	Not allowed

Manipulating LOBs using locators

A LOB locator is a host variable with a value that represents a single LOB value in the database server. LOB locators provide a mechanism for you to easily manipulate very large objects in application programs

without having to store the entire LOB value on the client machine where the application program might be running.

Because LOB values can be very large, the transfer of these values from the database server to host variables in client application programs can be time consuming. Also, application programs typically process LOB values a piece at a time, rather than as a whole. For these cases, the application can use a *large object locator* (LOB locator) to reference the LOB value.

For example, when selecting a LOB value, an application program could handle the value in either of these two ways:

- Select the entire LOB value and place it into an equally large host variable. This method is acceptable if the application program is going to process the entire LOB value at once.
- Select the LOB value into a LOB locator. Then, using the LOB locator, the application program can issue subsequent database operations on the LOB value (such as using it as a parameter to the scalar functions SUBSTR, CONCAT, COALESCE, LENGTH, doing an assignment, searching the LOB value with LIKE or POSSTR, or using it as a parameter to a user-defined function or procedure) by supplying the LOB locator value as input. The resulting output of the LOB locator operation, for example, the amount of data that is assigned to a client host variable, would then typically be a small subset of the input LOB value.

LOB locators can also represent more than just base values; they can also represent the value associated with a LOB expression. For example, a LOB locator might represent the value associated with:

```
SUBSTR(lob_value_1 CONCAT lob_value_2 CONCAT lob_value_3 , 42, 6000000)
```

For non-locator-based host variables in an application program, when a null value is selected into that host variable, the indicator variable is set to -1, signifying that the value is null. For LOB locators, however, the meaning of indicator variables is slightly different. Because a LOB locator host variable itself can never be null, a negative indicator variable value indicates that the LOB value represented by the LOB locator is null. The null information is kept local to the client by virtue of the indicator variable value (the server does not track null values with valid LOB locators).

A LOB locator represents a value, not a row or location in the database. Therefore, after a value is selected into a LOB locator, no action that is subsequently performed on the original row or table will affect the value that is referenced by the LOB locator. The value associated with a LOB locator is valid until the transaction ends, or until the LOB locator is explicitly freed, whichever comes first.

A LOB locator is also not a database type, and it is never stored in the database. As a result, it cannot participate in views or check constraints. However, values for the SQLTYPE field of the SQLDA exist for LOB locators so that they can be described within an SQLDA structure that is used by FETCH, OPEN, CALL and EXECUTE statements.

For more information about manipulating LOBs with LOB locators, see [Saving storage when manipulating LOBs by using LOB locators \(Db2 Application programming and SQL\)](#).

Datetime values

Datetime values are neither strings nor numbers. Nevertheless, datetime values can be used in certain arithmetic and string operations and are compatible with certain strings.

Moreover, strings can represent datetime values, as discussed in [“String representations of datetime values”](#) on page 120.

Date

A *date* is a three-part value (year, month, and day) designating a point in time using the Gregorian calendar, which is assumed to have been in effect from the year 1 A.D.

⁴ The range of the year part is 0001 to 9999. The range of the month part is 1 to 12. The range of the day part is 1 to 28, 29, 30, or 31, depending on the month and year.

The internal representation of a date is a string of 4 bytes. Each byte consists of two packed decimal digits. The first 2 bytes represent the year, the third byte the month, and the last byte the day.

The length of a DATE column as described in the catalog is the internal length, which is 4 bytes. The length of a DATE column as described in the SQLDA is the external length, which is 10 bytes unless a date exit routine was specified when your Db2 subsystem was installed. (Writing a date exit routine is described in [Date and time routines \(Db2 Administration Guide\)](#).) In that case, the string format of a date can be up to 255 bytes in length. Accordingly, DCLGEN⁵ defines fixed-length string variables for DATE columns with a length equal to the value of the field LOCAL DATE LENGTH on installation panel DSNTIP4, or a length of 10 bytes if a value for the field was not specified.

A character-string representation must have an actual length that is not greater than 255 bytes and must not be a CLOB or DBCLOB.

Related reference

[DATE FORMAT field \(DATE DECP value\) \(Db2 Installation and Migration\)](#)

[LOCAL DATE LENGTH field \(DATELEN DECP value\) \(Db2 Installation and Migration\)](#)

[DCLGEN \(declarations generator\) subcommand \(DSN\) \(Db2 Commands\)](#)

Time

A *time* is a three-part value (hour, minute, and second) designating a time of day using a 24-hour clock. The range of the hour part is 0 to 24. The range of the minute and second parts is 0 to 59. If the hour is 24, the minute and second parts are both zero.

The internal representation of a time is a string of 3 bytes. Each byte consists of two packed decimal digits. The first byte represents the hour, the second byte the minute, and the last byte the second.

The length of a TIME column as described in the catalog is the internal length which is 3 bytes. The length of a TIME column as described in the SQLDA is the external length which is 8 bytes unless a time exit routine was specified when the Db2 subsystem was installed. (Writing a time exit routine is described in [Date and time routines \(Db2 Administration Guide\)](#).) In that case, the string format of a time can be up to 255 bytes in length. Accordingly, DCLGEN [“Date” on page 118](#) defines fixed-length string variables for TIME columns with a length equal to the value of the field LOCAL TIME LENGTH on installation panel DSNTIP4, or a length of 8 bytes if a value for the field was not specified.

A character-string representation must have an actual length that is not greater than 255 bytes and must not be a CLOB or DBCLOB.

Related reference

[LOCAL TIME LENGTH field \(TIMELEN DECP value\) \(Db2 Installation and Migration\)](#)

[DCLGEN \(declarations generator\) subcommand \(DSN\) \(Db2 Commands\)](#)

Timestamp

A *timestamp* is a six-part or seven-part value (year, month, day, hour, minute, second, and optional fractional second) with an optional time zone specification, that represents a date and time.

The time portion of a timestamp value can include a specification of fractional seconds. The number of digits in the fractional seconds portion is specified using an attribute in the range 0–12 with a default of 6. The time zone is the difference in hours and minutes between local time and UTC. The range of the hour offset is -12 to 14, and the minute offset is 00 to 59. The optional time zone is specified in the format \pm th:tm, with values ranging from -12:59 to +14:00. A timestamp data type is `TIMESTAMP WITHOUT TIME ZONE` (generally referred to as `TIMESTAMP`) or `TIMESTAMP WITH TIME ZONE`.

⁴ Historical dates do not always follow the Gregorian calendar. Dates between 1582-10-04 and 1582-10-15 are accepted as valid dates although they never existed in the Gregorian calendar.

⁵ DCLGEN is a Db2 DSN subcommand for generating table declarations for designated tables or views. The declarations are stored in z/OS data sets, for later inclusion in Db2 source programs.

TIMESTAMP WITHOUT TIME ZONE

The internal representation of a timestamp is a string of 7 to 13 bytes, each of which consists of two packed decimal digits. The first 4 bytes represent the date, the next 3 bytes the time, and the remaining bytes the fractional seconds based on the precision of the timestamp.

The length of a TIMESTAMP WITHOUT TIME ZONE column as described in the catalog is the internal length, which is 7 to 13 bytes.

The length of a TIMESTAMP WITHOUT TIME ZONE column as described in the SQLDA is in the range 19–32 bytes, which corresponds to the length for the character-string representation of the value. For example, a 19 byte character-string representation has no fractional seconds; a 26 byte character-string representation has 6 digits of fractional seconds; and a 29 byte character-string representation has 9 digits of fractional seconds.

A character-string representation must have an actual length that is not greater than 255 bytes and must not be a CLOB or DBCLOB.

TIMESTAMP WITH TIME ZONE

The external representation of a TIMESTAMP WITH TIME ZONE value is the local timestamp followed by the time zone offset. For example, New York is 5 hours behind London during standard time, so New York time "8:15" on 2010-02-10 can be represented as '2010-02-10-08.15.00-5:00'. This timestamp with time zone value represents a UTC value '2010-02-10-13.15.00', which is derived by subtracting the time zone offset from local timestamp.

The internal representation of a timestamp is a string of 9 to 15 bytes that contains the UTC timestamp followed by the time zone. Each byte consists of 2 packed decimal digits. The first byte consists of two packed decimal digits representing time zone hour and the first bit is used to represent the sign of the time zone offset. The second byte of time zone, representing the time zone minute, also consists of two packed decimal digits. For example, time zone "-3:30" is represented as X'8330' and time zone "5:30" is represented as X'0530'.

The length of a TIMESTAMP WITH TIME ZONE column as described in the catalog is the internal length, which is between 9 to 15 bytes (a 7 to 13 bytes timestamp followed by 2 bytes time zone).

The length of a TIMESTAMP WITH TIME ZONE column as described in the SQLDA is the external length, which is in the range 147–160 bytes and corresponds to the length for the character-string representation of the value. For example, a 147 byte character representation has no fractional seconds, and a 160 byte character-string representation has 12 digits of fractional seconds, where the time zone component is 7 bytes.

A character-string representation must have an actual length that is not greater than 255 bytes and must not be a CLOB or DBCLOB. DCLGEN therefore defines 147 to 160 byte, varying-length string variables for TIMESTAMP WITH TIME ZONE columns.

Related concepts

Datetime constants

A *datetime constant* is a character string constant of a particular format.

Datetime host variables

Character-string host variables are normally used to contain date, time, and timestamp values. However, date, time, and timestamp host variables can also be specified in Java as `java.sql.Date`, `java.sql.Time`, and `java.sql.Timestamp`, respectively.

String representations of datetime values

Dates, times, and timestamp values can be represented by strings. For many host languages, there are no special SQL constants for datetime values and, except for Java, no host variables with a data type of date, time, or timestamp. Thus, to be retrieved, a datetime value must be assigned to a string variable.

Values whose data types are DATE, TIME, TIMESTAMP WITHOUT TIME ZONE, or TIMESTAMP WITH TIME ZONE are represented in a form that is transparent to the user of SQL. Dates, times, and timestamps (with or without time zones) can also be represented by strings. These representations directly concern the SQL

user because, for many host languages there are no special SQL constants or host variables with a data type for DATE, TIME, TIMESTAMP WITHOUT TIME ZONE, or TIMESTAMP WITH TIME ZONE values (for variables with Java). Thus, to be retrieved, a datetime value must be assigned to a string variable. The format of the resulting string depends on the default date format and the default time format that is in effect when the statement is prepared.

Each datetime value is assigned an encoding scheme. This encoding scheme is used when the datetime value is converted from its internal form to the string representation in the form of the mixed CCSID if the field MIXED DATA is YES on installation panel DSNTIPF. Otherwise the SBCS CCSID of the assigned encoding scheme is used. For Unicode, the mixed CCSID is always used. The following table shows how the encoding scheme is determined:

Table 18. The encoding scheme of datetime values

Datetime expression	Result encoding scheme
Columns	The same encoding scheme as the table that contains the column
Host variables	If the statement references: <ul style="list-style-type: none"> • A single encoding scheme - The same encoding scheme • Multiple encoding schemes - The application encoding scheme
Special registers	If the statement references: <ul style="list-style-type: none"> • A single encoding scheme - The same encoding scheme • Multiple encoding schemes - The application encoding scheme
Expressions	If the statement references: <ul style="list-style-type: none"> • A single encoding scheme - The same encoding scheme • Multiple encoding schemes - The application encoding scheme

For ASCII and EBCDIC, a string representation of a datetime value must be a character string. For Unicode, a string representation of a datetime value can be either a character string or a graphic string. Thus, the only time a graphic string can be used for a datetime value is when the encoding scheme is Unicode.

In host languages other than Java, a datetime value must be assigned to a string variable. When a date or time is assigned to a string variable, the string format is determined by a precompiler option or subsystem parameter. When a string representation of a datetime value is used in other operations, it is converted to a datetime value. However, this can be done only if the string representation is recognized by Db2 or an exit provided by the installation and the other operand is a compatible datetime value. An input string representation of a date or time with LOCAL specified must have an actual length that is not greater than 255 bytes.

Datetime values that are represented by strings can appear in contexts that require values whose data types are DATE, TIME, TIMESTAMP WITHOUT TIME ZONE, or TIMESTAMP WITH TIME ZONE. A string representation of a date, time or timestamp (with or without time zone) can be passed as an argument to the DATE, TIME, TIMESTAMP, or TIMESTAMP_TZ function to obtain a datetime value. A CAST specification can also be used to turn a character representation of a date, time, or timestamp (with or without time zone) into a datetime value.

Date strings:

A string representation of a date is a string that starts with a digit and has a length of at least 8 characters. Trailing blanks can be included, leading blanks are not allowed, and leading zeros can be omitted in the month and day portions.

The following table shows the valid string formats for dates. Each format is identified by name and includes an associated abbreviation (for use by the CHAR function) and an example of its use. For an installation-defined date string format, the format and length must have been specified when Db2 was installed. They cannot be listed here.

Table 19. Formats for string representations of dates

Format name	Abbreviation	Date format	Example
International Standards Organization	ISO	yyyy-mm-dd	1987-10-12
IBM USA standard	USA	mm/dd/yyyy	10/12/1987
IBM European standard	EUR	dd.mm.yyyy	12.10.1987
Japanese industrial standard Christian era	JIS	yyyy-mm-dd	1987-10-12
Installation-defined	LOCAL	Any installation-defined form	—

Time strings:

A string representation of a time is a string that starts with a digit, and has a length of at least 4 characters. Trailing blanks can be included, leading blanks are not allowed, and leading zeros can be omitted in the hour part of the time; seconds can be omitted entirely. If you choose to omit seconds, an implicit specification of 0 seconds is assumed. Thus 13.30 is equivalent to 13.30.00.

The following table shows the valid string formats for times. Each format is identified by name and includes an associated abbreviation (for use by the CHAR function) and an example of its use. In the case of an installation-defined time string format, the format and length must have been specified when your Db2 subsystem was installed. They cannot be listed here.

Table 20. Formats for string representations of times

Format name	Abbreviation	Time format	Example
International Standards Organization ¹	ISO ¹	hh.mm.ss	13.30.05
IBM USA standard	USA	hh:mm AM or PM	1:30 PM
IBM European standard	EUR	hh.mm.ss	13.30.05
Japanese industrial standard Christian era	JIS	hh:mm:ss	13:30:05
Installation-defined	LOCAL	Any installation-defined form	—

Note: 1. This is an earlier version of the ISO format. JIS can be used to get the current ISO format.

In the USA format:

- The minutes can be omitted, thereby specifying 00 minutes. For example, 1 PM is equivalent to 1:00 PM.
- The letters A, M, and P can be lowercase.
- A single blank must precede the AM or PM.
- The hour must not be greater than 12 and cannot be 0 except for the special case of 00:00 AM.

Using the ISO format of the 24-hour clock, the correspondence between the USA format and the 24-hour clock is as follows:

- 12:01 AM through 12:59 AM correspond to 00.01.00 through 00.59.00
- 01:00 AM through 11:59 AM correspond to 01.00.00 through 11.59.00
- 12:00 PM (noon) through 11:59 PM correspond to 12.00.00 through 23.59.00
- 12:00 AM (midnight) corresponds to 24.00.00
- 00:00 AM (midnight) corresponds to 00.00.00

Timestamp strings:

A string representation of a timestamp is a character or graphic string that starts with a digit and has a length of at least 16 characters.

The character or graphic string must contain a value that conforms to one of the formats listed in [“Datetime constants” on page 174](#), subject to the following rules:

- leading blanks are not allowed
- trailing blanks can be included
- leading zeros can be omitted from the month, day, hour, and time zone hour elements of the timestamp. An implicit specification of 0 is assumed for any digit that is omitted.
- the hour can be 24 if the minutes, seconds, and any fractional seconds are all zeroes.
- leading zeros must be included for the minute, second, and time zone minute elements of the timestamp.
- the number of digits of fractional seconds can vary from 0 to 12. An implicit specification of 0 is assumed if fractional seconds are omitted.
- the separator character that follows the seconds element can be omitted if fractional seconds are not included.
- an optional single blank can be included between the time and the time zone.
- an optional time zone can be included, in one of the following formats:
 - \pm h:tm, with values ranging from -24:00 to +24:00. A value of -0:00 is treated the same as a value of +0:00.
 - \pm th, with values ranging from -24 to +24, and an implicit specification of 00 is assumed for the time zone minute element.
 - uppercase Z to specify UTC

If a string representation of a timestamp is implicitly cast to a value with a timestamp data type, the timestamp precision is assumed to be 6, regardless of the number of digits of fractional seconds in the string. Beyond the sixth digit that represents fractional seconds, the digits are truncated and the missing digits are assumed to be zeros. For example, 1990-3-2-8.30.00.10 is equivalent to 1990-03-02-08.30.00.100000. A string representation of a timestamp can be given a different timestamp precision by explicitly casting the value to a timestamp with a specified precision or, in the case of a constant, preceding the string with the `TIMESTAMP` keyword (for example, `TIMESTAMP 2007-03-28-14.50.35.123`; has the `TIMESTAMP(3)` data type).

If a string representation of a timestamp is implicitly cast to a `TIMESTAMP WITHOUT TIME ZONE` value, the string must not contain a time zone.

SQL statements also support the ODBC or JDBC string representation of a timestamp as an input value only. The ODBC and JDBC string representation of a timestamp has the form `yyyy-mm-dd hh:mm:ss.nnnnnn`.

LOCAL date and time exits: For LOCAL, the date exit for ASCII data is `DSNXVDTA`, the date exit for EBCDIC is `DSNXVDTX`, and the date exit for Unicode is `DSNXVDTU`. For LOCAL, the time exit for ASCII data is `DSNXVTMA`, the time exit for EBCDIC is `DSNXVTMX`, and the time exit for Unicode is `DSNXVTMU`.

Determination of the implicit time zone

Db2 uses the `IMPLICIT_TIMEZONE` parameter of `DSNHDECP` to implicitly determine the time zone to associate with a value that does not have a time zone on assignment to a `TIMESTAMP WITH TIME ZONE` column or variable.

The `IMPLICIT_TIMEZONE` parameter of `DSNHDECP` is used to support operations that combine `TIMESTAMP WITHOUT TIME ZONE` values and `TIMESTAMP WITH TIME ZONE` values and indicates the time zone to associate with `TIMESTAMP WITHOUT TIME ZONE` values. For example, on assignment of a value that does not have time zone information (the `TIMESTAMP WITHOUT TIME ZONE` data type, or a string representation of a timestamp without a time zone) to a `TIMESTAMP WITH TIME ZONE` target such as a column or variable, Db2 implicitly determines the time zone to associate with the value. The implicit time zone is determined as follows:

- If `IMPLICIT_TIMEZONE` is not specified or is specified as `CURRENT`, the implicit time zone is the value of the `CURRENT TIME ZONE` special register.
- If `IMPLICIT_TIMEZONE` is specified as `SESSION`, the implicit time zone is the value of the `SESSION TIME ZONE` special register.
- If `IMPLICIT_TIMEZONE` is specified as a character string in the format of `'±th:tm'`, the implicit time zone is the time zone value represented by the character string.

Restrictions on the use of local datetime formats

When you use a `LOCAL` format for date or time values, certain restrictions apply to the use of those values as input, as output, and for use in binding a package.

The following rules apply to the character-string representation of dates and times:

For input: In distributed operations, Db2 as a server uses its local date or time routine to evaluate host variables and constants. This means that character-string representation of dates and times can be:

- One of the standard formats
- A format recognized by the server's local date/time exit

For output: With `DRDA` access, Db2 as a server returns date and time host variables in the format defined at the server. To have date and time host variables returned in another format, use `CHAR(date-expression, XXXX)` where `XXXX` is `JIS`, `EUR`, `USA`, `ISO`, or `LOCAL` to explicitly specify the specific format.

For BIND PACKAGE COPY: When you use the `COPY` option to bind a copy of a local package at a remote site, Db2 uses the `ISO` format for output values in the remote package unless the `SQL` statement explicitly specifies a different format. Input values can be specified in the format described previously.

Row ID values

A *row ID* is a value that uniquely identifies a row in a table. A column or a host variable can have a row ID data type.

A `ROWID` column enables queries to be written that navigate directly to a row in the table because the column implicitly contains the location of the row. Each value in a `ROWID` column must be unique. Although the location of the row might change, for example across a table space reorganization, Db2 maintains the internal representation of the row ID value permanently. When a row is inserted into the table, Db2 generates a value for the `ROWID` column unless one is supplied. If a value is supplied, it must be a valid row ID value that was previously generated by Db2 and the column must be defined as `GENERATED BY DEFAULT`. Users cannot update the value of a `ROWID` column.

The internal representation of a row ID value is transparent to the user. The value is never subject to character conversion because it is considered to contain `BIT` data. The length of a `ROWID` column as described in the `LENGTH` column of catalog table `SYSCOLUMNS` is the internal length, which is 17 bytes. The length as described in the `LENGTH2` column of catalog table `SYSCOLUMNS` is the length of a retrieved `ROWID` value, which is 40 bytes. The retrieved `ROWID` value is not permanent. If a commit operation

and a REORG on the table space occur after the value is inserted, and before the value is retrieved, the physical location of the row might change.

A ROWID column can be either user-defined or implicitly generated by Db2. You can use the CREATE TABLE statement or the ALTER TABLE statement to define a ROWID column. If you define a LOB column in a table and the table does not have a ROWID column, Db2 implicitly generates a ROWID column. Db2 takes the following actions:

- Creates the column with a name of DB2_GENERATED_ROWID_FOR_LOBS nn .
Db2 appends nn only if the column name already exists in the table, replacing nn with '00' and incrementing by '1' until the name is unique within the row.
- Defines the column as GENERATED ALWAYS and IMPLICITLY HIDDEN.
- Appends the column to the end of the row after all the other explicitly defined columns.

An implicitly hidden ROWID column can also be explicitly defined with the IMPLICITLY HIDDEN clause.

If you add a ROWID column to a table that already has an implicitly generated hidden ROWID column, Db2 ensures that the corresponding values in each column are identical. If the ROWID column that you add is defined as GENERATED BY DEFAULT, Db2 changes the attribute of the hidden ROWID column to GENERATED BY DEFAULT.

Related concepts

[ROWID data type \(Introduction to Db2 for z/OS\)](#)

[Rules for inserting data into a ROWID column \(Db2 Application programming and SQL\)](#)

Related tasks

[Specifying direct row access by using row IDs \(Db2 Application programming and SQL\)](#)

Related reference

[ROWID scalar function](#)

The ROWID function returns a row ID representation of its argument.

XML values

An XML value represents well-formed XML in the form of an XML document, XML content, or a sequence of XML nodes.

An XML value that is stored in a table as the value of a column that is defined with the XML data type must be a well-formed XML document. XML values are processed in an internal representation that is not comparable to any string value. The only predicates that can be applied to the XML data type are the XMLEXISTS predicate and the NULL predicate.

An XML value can be transformed into a serialized string value that represents the XML document by using the XMLSERIALIZE function. Similarly, a string value that represents an XML document can be transformed to an XML value by using the XMLPARSE function.

The XML data type has a variable length and allows for a wide range of sizes. Although data of this type has no defined maximum length, it does have an effective maximum length limit when treated as a serialized string value that represents XML. The maximum effective length is the same as the Db2 limit for a LOB data value. Db2 treats XML string data in a similar manner as LOB data to accommodate very large XML values. Thus, XML values are constrained by the same maximum length limit as LOB data. Unlike the LOB data type which has a LOB locator type, there is no XML locator type.

Restrictions when using XML values: With a few exceptions, you can use XML values in the same contexts in which you can use other data type. XML values cannot be used in the following contexts:

- SELECT lists that are preceded by the DISTINCT clause
- GROUP BY clauses
- ORDER BY clauses
- A subselect of a fullselect with a set operator that is not UNION ALL

- Basic predicates, quantified predicates, BETWEEN predicates, DISTINCT predicates, IN predicates, or LIKE predicates
- Aggregate functions with the DISTINCT keyword
- Primary, unique, or foreign keys
- CREATE TYPE statements

No host languages have any built-in support for an XML data type.

User-defined data types

A *user-defined data type* is a data type that is defined using a CREATE TYPE statement.

The following types of user-defined data type are supported:

Distinct types

A *distinct type* is a user-defined data type that is based on existing built-in Db2 data types.

A distinct type is internally the same as a built-in data type, but Db2 treats them as a separate and incompatible type for semantic purposes. Defining your own distinct type ensures that only functions that are explicitly defined on a distinct type can be applied to its instances.

For more information, see [“Distinct types ” on page 23](#).

Array types

A user-defined *array type* is a data type that is defined as an array of elements. A user-defined array type can be either an *ordinary array* or *associative array*.

A user-defined ordinary array type has a maximum cardinality, which is specified on the CREATE TYPE (array) statement. A user-defined associative array has a maximum cardinality of 2 billion.

An *array value* is a structure that contains an ordered collection of elements. All elements of an array value must have the same data type. The cardinality of the array is equal to the number of elements in the array.

For more information, see [“Array types and values” on page 127](#).

Related concepts

[Comparison of distinct types \(Db2 Application programming and SQL\)](#)

[User-defined type assignments](#)

User-defined type assignments include distinct type assignments and array assignments.

[User-defined type comparisons](#)

User-defined type comparisons include distinct type comparisons and array comparisons.

Distinct types

A *distinct type* is a user-defined data type that shares its internal representation with a built-in data type (its *source type*), but is considered to be a separate and incompatible data type for most operations.

For example, the semantics for a picture type, a text type, and an audio type that all use the built-in data type BLOB for their internal representation are quite different. A distinct type is created with the SQL statement CREATE TYPE.

For example, the following statement creates a distinct type named AUDIO:

```
CREATE TYPE AUDIO AS BLOB (1M);
```

Although AUDIO has the same representation as the built-in data type BLOB, it is a separate data type that is not comparable to a BLOB or to any other data type. This inability to compare AUDIO to other data types allows functions to be created specifically for AUDIO and assures that these functions cannot be applied to other data types.

The name of a distinct type is qualified with a schema name. The implicit schema name for an unqualified name depends on the context in which the distinct type appears. If an unqualified distinct type name is used:

- In a CREATE TYPE statement or the object of DROP, COMMENT, GRANT, or REVOKE statement, Db2 uses the normal process of qualification by authorization ID to determine the schema name.
- In any other context, Db2 uses the SQL path to determine the schema name. Db2 searches the schemas in the path, in sequence, and selects the first schema in the path such that the distinct type exists in the schema and the user has authorization to use the data type. For a description of the SQL path, see [“SQL path”](#) on page 85.

A distinct type does not automatically acquire the functions and operators of its source type because they might not be meaningful. (For example, it might make sense for a "length" function of the AUDIO type to return the length in seconds rather than in bytes.) Instead, distinct types support *strong typing*. Strong typing ensures that only the functions and operators that are explicitly defined on a distinct type can be applied to that distinct type. However, a function or operator of the source type can be applied to the distinct type by creating an appropriate user-defined function. The user-defined function must be sourced on the existing function that has the source type as a parameter. For example, the following series of SQL statements shows how to create a distinct type named MONEY based on data type DECIMAL(9,2), how to define the + operator for the distinct type, and how the operator might be applied to the distinct type:

```
CREATE TYPE MONEY AS DECIMAL(9,2);
CREATE FUNCTION "+"(MONEY,MONEY)
  RETURNS MONEY
  SOURCE SYSIBM."+"(DECIMAL(9,2),DECIMAL(9,2));
CREATE TABLE SALARY_TABLE
  (SALARY MONEY,
   COMMISSION MONEY);
SELECT SALARY + COMMISSION FROM SALARY_TABLE;
```

A distinct type is subject to the same restrictions as its source type. For example, if a CLOB value is not allowed as input to a function, you cannot specify a distinct type that is based on a CLOB as input.

The comparison operators are automatically generated for distinct types, except those that are based on a CLOB, DBCLOB, or BLOB. In addition, Db2 automatically generates functions for every distinct type that support casting from the source type to the distinct type and from the distinct type to the source type. For example, for the AUDIO type created above, these are generated cast functions:

```
FUNCTION schema-name.BLOB (schema-name.AUDIO) RETURNS SYSIBM.BLOB (1M)
FUNCTION schema-name.AUDIO (SYSIBM.BLOB (1M)) RETURNS schema-name.AUDIO
```

Array types and values

A user-defined *array type* is a data type that is defined as an array of elements. A user-defined array type can be either an *ordinary array* or *associative array*.

A user-defined ordinary array type has a maximum cardinality, which is specified on the CREATE TYPE (array) statement. A user-defined associative array has a maximum cardinality of 2 billion.

Array values

An *array value* is a structure that contains an ordered collection of elements. All elements of an array value must have the same data type. The cardinality of the array is equal to the number of elements in the array.

An array value can be non-empty, empty (cardinality zero), or null. The individual elements in the array can be null or not null. An empty array, an array value of null, and an array for which all elements are the null value are different from each other. An uninitialized array is a null array.

The following example demonstrates the difference between an empty array, a null array, and an array for which individual elements are null.

```
SET PHONELIST = ARRAY[];
/* Set an entire array to empty */
```

```

SET PHONELIST = NULL;
/* Set an entire array to the NULL value */
SET PHONELIST = ARRAY[NULL];
/* Set one element of an array to NULL */
SET PHONELIST = ARRAY[NULL, NULL, NULL];
/* Set three elements of an array to NULL */

```

An *ordinary array* has a defined upper bound on the number of elements, which is known as the maximum cardinality. Each element in the array is referenced by an associated index value that represents the position of that element in the array. The data type of the index values is INTEGER. If n is the number of elements in an ordinary array, the ordinal position that is associated with each element is an integer value greater than or equal to 1 and less than or equal to n .

Unlike the maximum cardinality of an array in programming languages such as C, the maximum cardinality of an ordinary array in SQL is not related to the physical representation of the array. The amount of memory that is required to represent the value of an ordinary array is usually proportional to the cardinality of the array, and not to the maximum cardinality of the array type. When an ordinary array is referenced, all of the values in the array are stored in main memory. Therefore, ordinary arrays that contain a large amount of data consume large amounts of main memory.

An *associative array* has no predefined upper bound on the number of elements. An associative array contains an ordered set of zero or more elements, where each element in the array is ordered by and can be referenced by an associated index value. The data type of the index values can be an integer or a character string other than a CLOB, but all index values for the array must have the same data type. The index values of an associative array are unique, and do not need to be contiguous.

A *user-defined array type* is a user-defined data type that is defined as an array. A global variable, an SQL variable or SQL parameter can be defined as a user-defined array type. Additionally, the result of an invocation of the built-in ARRAY_DELETE or TRIM_ARRAY functions, or the result of a CAST specification, can be a user-defined array type. An element of a user-defined array type can be referenced anywhere that an expression that returns the same data type as an element of that array can be used.

An *unnamed array type* is an array without an associated user-defined data type. The result of invocation of the aggregate built-in function ARRAY_AGG or of an array constructor is an array without an associated user-defined data type. An element of an array without an associated user-defined array type cannot be directly referenced.

The value of an array index can be specified by an expression. That expression can include a reference to a column. If a column is defined with a column mask, the column mask is applied using the normal rules for applying a column mask.

The value of an index for an array element is never null. If an expression specifies a value for an index, and the expression evaluates to the null value, the null value is returned for the array value.

An array value can be specified using one of the following methods:

- A simple reference to a global variable, an SQL variable, or SQL parameter that is a user-defined array type.
- Invocation of the ARRAY_AGG function.
- Invocation of the ARRAY_DELETE or TRIM_ARRAY built-in functions.
- Use of an array constructor.
- Invocation of a CAST specification that returns an array value.

An array value cannot be stored in a table or returned to an external application.

Datetime data in the elements of an array is considered to be CCSID UNICODE (1208).

Related reference

[Array constructor](#)

An array constructor returns an ordinary array. An array constructor is specified by a list of expressions or a fullselect.

[ARRAY_AGG aggregate function](#)

The ARRAY_AGG function returns an array in which each value of the input set is assigned to an element of the array.

TRIM_ARRAY scalar function

The TRIM_ARRAY function deletes elements from the end of an ordinary array.

CREATE MASK statement

The CREATE MASK statement creates a column mask at the current server. A *column mask* is used for column access control and specifies the value that should be returned for a specified column.

CALL statement

The CALL statement invokes a stored procedure.

Promotion of data types

Data types can be classified into groups of related data types. Within such groups, an order of precedence exists in which one data type is considered to precede another data type. This precedence enables Db2 to support the *promotion* of one data type to another data type that appears later in the precedence order.

For example, Db2 can promote the data type CHAR to VARCHAR and the data type INTEGER to DOUBLE PRECISION; however, Db2 cannot promote a CLOB to a VARCHAR.

Db2 considers the promotion of data types when:

- Performing function resolution (see [“Function resolution”](#) on page 239)
- Casting distinct types (see [“Casting between data types”](#) on page 130)
- Assigning built-in data types to distinct types (see [“User-defined type assignments”](#) on page 153)

For each data type, the following table shows the precedence list (in order) that Db2 uses to determine the data types to which the data type can be promoted. The table indicates that the best choice is the same data type and not promotion to another data type. The table also shows data types that are considered equivalent during the promotion process. For example, CHARACTER and GRAPHIC are considered to be equivalent data types.

Table 21. Precedence of data types

Data type ^{1,2}	Data type precedence list (in best-to-worst order)
SMALLINT ³	SMALLINT, INTEGER, BIGINT, decimal, real, double, DECFLOAT
INTEGER ³	INTEGER, BIGINT, decimal, real, double, DECFLOAT
BIGINT ³	BIGINT, decimal, real, double, DECFLOAT
decimal ³	decimal, real, double, DECFLOAT
real	real, double, DECFLOAT
double	double, DECFLOAT
DECFLOAT	DECFLOAT
CHAR or GRAPHIC	CHAR or GRAPHIC, VARCHAR or VARGRAPHIC, CLOB or DBCLOB
VARCHAR or VARGRAPHIC	VARCHAR or VARGRAPHIC, CLOB or DBCLOB
CLOB or DBCLOB	CLOB or DBCLOB
BINARY	BINARY, VARBINARY, BLOB
VARBINARY	VARBINARY, BLOB
BLOB	BLOB
DATE	DATE

Table 21. Precedence of data types (continued)

Data type ^{1,2}	Data type precedence list (in best-to-worst order)
TIME	TIME
TIMESTAMP WITHOUT TIME ZONE	TIMESTAMP WITHOUT TIME ZONE or TIMESTAMP WITH TIME ZONE
TIMESTAMP WITH TIME ZONE	TIMESTAMP WITHOUT TIME ZONE or TIMESTAMP WITH TIME ZONE
ROWID	ROWID
XML	XML
A distinct type	The same distinct type

Notes:

1. The data types in lowercase letters represent the following data types:

decimal

DECIMAL(*p,s*) or NUMERIC(*p,s*)

real

REAL or FLOAT(*n*) where *n* is not greater than 21

double

DOUBLE, DOUBLE PRECISION, FLOAT or FLOAT(*n*) where *n* is greater than 21

2. Other synonyms for the listed data types are considered to be the same as the synonym listed.

3. Real and double are checked for function resolution purposes only. Additionally, the number of significant digits (even for DECFLOAT(16)), and the exponent range of DECFLOAT exceeds that of real and double (double has 16 significant digits). Therefore, DECFLOAT values will not be promoted to real or double.

Casting between data types

There are many occasions when a value with a given data type needs to be *cast* (changed) to a different data type or to the same data type with a different length, precision, or scale.

Data type promotion is one example where the promotion of one data type to another data type requires that the value be cast to the new data type. A data type that can be changed to another data type is *castable* from the base data type to the target data type.

The casting of one data type to another can occur implicitly or explicitly. The cast functions, CAST specification, or XMLCAST specification can be used to explicitly change a data type, depending on the data types involved. In addition, when a sourced user-defined function is created, the data types of the parameters of the source function must be castable to the data types of the function that is being created.

If truncation occurs when any data type is cast to a character or graphic data type, a warning occurs if any non-blank characters are truncated. The warning also occurs if any characters are truncated when a BLOB operand is cast, or if the time zone characters are truncated when a TIMESTAMP WITH TIME ZONE operand is cast to a string. This truncation behavior is similar to retrieval assignment of character or graphic strings. See "Retrieval assignment for character and graphic strings" in ["String assignments"](#) on page 149.

If truncation occurs when casting to a binary string, an error is returned.

For casts that involve a distinct type as either the data type to be cast to or from, [Table 22 on page 131](#) shows the supported casts.

For casting a parameter marker or NULL value to the XML data type, the CAST specification can be used. XML input can also be specified for the CAST specification when the result data type is XML.

Casts that involve an array type as the target and a non-null source value must conform to the following rules:

- If the source value is an array with a user-defined array type:
 - The target array type must be the same user-defined array type.
 - If the target user-defined array type is an ordinary array, the cardinality of the source array value must be less than or equal to the maximum cardinality of the target array type.
- If the source value is an array without an associated user-defined array type:
 - The elements in the source array value must be castable to the data type of the elements of the target array type.
 - The index values for the source array value must be castable to the data type of the index of the target array type.
 - If the target user-defined array type is an ordinary array, the cardinality of the source array value must be less than or equal to the maximum cardinality of the target array type.

Table 22. Supported casts when a distinct type is involved

Data type ...	Is castable to data type ...
Distinct type <i>DT</i>	Base data type of distinct type <i>DT</i>
Source data type of distinct type <i>DT</i>	Distinct type <i>DT</i>
Distinct type <i>DT</i>	Distinct type <i>DT</i>
Data type <i>A</i>	Distinct type <i>DT</i> where <i>A</i> is promotable to the base data type of distinct type <i>DT</i> (see “Promotion of data types” on page 129)
INTEGER	Distinct type <i>DT</i> if <i>DT</i> 's base data type is SMALLINT
DOUBLE	Distinct type <i>DT</i> if <i>DT</i> 's base data type is REAL
VARCHAR	Distinct type <i>DT</i> if <i>DT</i> 's base data type is CHAR or GRAPHIC
VARGRAPHIC	Distinct type <i>DT</i> if <i>DT</i> 's base data type is GRAPHIC or CHAR
VARBINARY	Distinct type <i>DT</i> if <i>DT</i> 's base data type is BINARY

When a distinct type is involved in a cast, a cast function that was generated when the distinct type was created is used. How Db2 chooses the function depends on whether function notation or CAST specification syntax is used. (For details, see [“Function resolution” on page 239](#) and [“CAST specification” on page 267](#), respectively.) Function resolution is similar for both. However, in CAST specification, when an unqualified distinct type is specified as the target data type, Db2 first resolves the schema name of the distinct type and then uses that schema name to locate the cast function.

For casts between built-in data types, the following table shows the supported casts.

Table 23. Supported casts between built-in data types

Cast from
data type –

To data type “1” on page 136

Cast from data type –	SMALLINT	INTEGER	BIGINT	DECIMAL	DOUBLE	VARCHAR	GRAPHIC	VARBINARY	VARBINARY	DATE	TIME	TIMESTAMP	TIME WITH TIME ZONE	TIMESTAMP WITH TIME ZONE	ROWXML
SMALLINT	Y		Y	Y	Y	Y	Y	Y	Y	Y	Y	Y	Y	Y	Y
INTEGER	Y	Y	Y	Y	Y	Y	Y	Y	Y	Y	Y	Y	Y	Y	Y
BIGINT	Y	Y	Y	Y	Y	Y	Y	Y	Y	Y	Y	Y	Y	Y	Y

(Note: The above table is a simplified representation of the data provided in the image. The original image shows a much larger and more complex table with many more data types and cast directions. The content is truncated for brevity.)

Table 23. Supported casts between built-in data types (continued)

Cast from data type –	To data type <u>"1" on page 136</u>																		
	S M A L L I N T	I N T E G E R	B I T	D E C I M A L	D E C I M A L	R E A L	U N D E R	C H A R	V A R C H A R	C L O B	G R A P H I C	V A R C H A R C H A R C B Y T E	V A R C H A R C H A R C B Y T E	T I M E S T A M P	W I T H O U T	T I M E	T I M E S T A M P	R O W I D	X M L
DECIMAL	Y	Y	Y	Y	Y	Y	Y	Y	Y	Y	Y	Y	Y	Y	Y	Y	Y	Y	Y
DECFLOAT	Y	Y	Y	Y	Y	Y	Y	Y	Y	Y	Y	Y	Y	Y	Y	Y	Y	Y	Y
REAL	Y	Y	Y	Y	Y	Y	Y	Y	Y	Y	Y	Y	Y	Y	Y	Y	Y	Y	Y

Table 23. Supported casts between built-in data types (continued)

Cast from data type –	To data type ^{“1”} on page 136																								
	S M A L L I N T	I N T E G E R	B I G I N T	D E C I M A L	D E C I M A L	R E A L	D O U B L E	C H A R	V A R C H A R	C L O B	G R A P H I C	V A R C H A R	D B C L O B	B I N A R Y	V A R B I N A R Y	B L O C K	D A T E	T I M E	W I T H I N T I M E	T I M E S T A M P	T I M E S T A M P W I T H I N T I M E	R O W I D	X M L		
DOUBLE	Y	Y	Y	Y	Y	Y	Y	Y	Y	Y	Y ^{“4”} on page 136	Y ^{“4”} on page 136													
CHAR	Y	Y	Y	Y	Y	Y	Y	Y	Y	Y	Y	Y	Y	Y	Y	Y	Y	Y	Y	Y	Y	Y	Y	Y	Y
VARCHAR	Y	Y	Y	Y	Y	Y	Y	Y	Y	Y	Y	Y	Y	Y	Y	Y	Y	Y	Y	Y	Y	Y	Y	Y	Y
CLOB							Y	Y	Y	Y	Y	Y	Y	Y	Y	Y									
GRAPHIC	Y	Y	Y	Y	Y	Y	Y ^{“2”} on page 136	Y ^{“2”} on page 136	Y ^{“2”} on page 136	Y	Y	Y	Y	Y	Y	Y	Y ^{“3”} on page 136	Y ^{“3”} on page 136	Y ^{“3”} on page 136	Y ^{“3”} on page 136					

Table 23. Supported casts between built-in data types (continued)

Cast from data type –	To data type “1” on page 136																	
	S	I	D	D	D	D	D	V	G	V	V	T	T	T	T	T	T	T
	M	N	E	E	R	O	C	A	R	A	A	Z	Z	Z	Z	Z	Z	Z
	A	B	C	C	A	A	H	H	R	R	R	O	O	O	O	O	O	O
	L	I	I	F	L	L	A	A	A	A	A	N	N	N	N	N	N	N
	I	G	M	L	A	A	E	E	E	E	E	E	E	E	E	E	E	E
	N	E	A	A	A	A	R	R	R	R	R	R	R	R	R	R	R	R
	T	R	T	T	T	T	R	R	R	R	R	R	R	R	R	R	R	R
VARGRAPHIC	Y	Y	Y	Y	Y	Y	Y	Y	Y	Y	Y	Y	Y	Y	Y	Y	Y	Y
							Y ²	Y ²	Y ²	Y	Y	Y	Y	Y	Y	Y	Y	Y ³
							on	on	on									on
							pag	pag	pag									pag
							e	e	e									e
							136	136	136									136
DBCLOB							Y ²	Y ²	Y ²	Y	Y	Y	Y	Y	Y			
							on	on	on									
							pag	pag	pag									
							e	e	e									
							136	136	136									
BINARY												Y	Y	Y				
VARBINARY												Y	Y	Y				
BLOB												Y	Y	Y				
DATE							Y	Y							Y		Y	
TIME							Y	Y							Y			
TIMESTAMP WITHOUT TIME ZONE							Y	Y							Y	Y	Y	Y

Table 23. Supported casts between built-in data types (continued)

Cast from data type –	To data type “1” on page 136
	T I M E S T A M P W I T H T I M E Z O N E
S M A L L I N T	D E C I M A L
I N T E G E R	B I T
	R O W I D
	V A R C H A R A C T E R
	G R A P H I C
	D I G I T A L
	V A R B I A N T
	B I N A R Y
	T I M E S T A M P W I T H T I M E Z O N E
	R O W I D
	X M L
TIMESTAMP WITH TIME ZONE	Y Y Y Y
ROWID	Y Y Y Y Y
XML	Y

Notes:

1. Other synonyms for the listed data types are considered to be the same as the synonym listed. Some exceptions exist when the cast involves character string data if the subtype is FOR BIT DATA.
2. The result length for these casts is 3 * LENGTH(graphic string).
3. These data types are castable between each other only if the data is Unicode.
4. [FL 502](#) The conversion returns a Unicode graphic result. The result value must only be used in a context that supports Unicode data

Table 24 on page 136 shows where to find information about the rules that apply when casting to the identified target data types.

Table 24. Rules for casting to a data type

Target data type	Rules
SMALLINT	“SMALLINT scalar function” on page 571
INTEGER	“INTEGER or INT scalar function” on page 483

Table 24. Rules for casting to a data type (continued)

Target data type	Rules
BIGINT	“BIGINT scalar function” on page 396
DECIMAL	“DECIMAL or DEC scalar function” on page 441
NUMERIC	“DECIMAL or DEC scalar function” on page 441
REAL	“REAL scalar function” on page 538
DOUBLE	“DOUBLE_PRECISION or DOUBLE scalar function” on page 451
DECFLOAT	“DECFLOAT scalar function” on page 437
CHAR	“CHAR scalar function” on page 405
VARCHAR	“VARCHAR scalar function” on page 615
CLOB	“CLOB scalar function” on page 415
GRAPHIC	“GRAPHIC scalar function” on page 465
VARGRAPHIC	“VARGRAPHIC scalar function” on page 632
DBCLOB	“DBCLOB scalar function” on page 434
BINARY	“BINARY scalar function” on page 397
VARBINARY	“VARBINARY scalar function” on page 614
BLOB	“BLOB scalar function” on page 400
DATE	“DATE scalar function” on page 425
TIME	“TIME scalar function” on page 584
TIMESTAMP WITHOUT TIME ZONE	<p>If the base data type is a character or graphic string, see “TIMESTAMP scalar function” on page 584, where one operand is specified. If the string contains a time zone, an error is returned.</p> <p>If the base data type is a DATE, the timestamp is composed of the specified date and a time of 00:00:00.</p> <p>If the source is a TIMESTAMP WITH TIME ZONE, the resulting timestamp is the timestamp without time zone element of the specified datetime value, which is the local timestamp in the corresponding time zone. For example: <code>cast ('2008-04-12-07.30.00.0-6:00' as TIMESTAMP)</code> returns <code>2008-04-12-07.30.00.0</code>.</p> <p>If the source type is a TIMESTAMP WITHOUT TIME ZONE the timestamp is the specified value.</p>
TIMESTAMP WITH TIME ZONE	<p>If the base data type is a character or graphic string or TIMESTAMP WITHOUT TIME ZONE, see “TIMESTAMP_TZ scalar function” on page 596, where two arguments are specified. The first argument is the string or timestamp. The second argument is the precision of the first argument. If the value contains a time zone, an error is returned.</p> <p>If the source type is a TIMESTAMP WITH TIME ZONE, the timestamp is the specified value.</p>
ROWID	“ROWID scalar function” on page 563

Table 25. The derived length of an argument when a built-in scalar function is invoked and implicit casting is required.

Source data type	Target data type				CLOB	DBCLOB	BLOB	TIME STAMP (precision)	DECFLOAT
	CHAR	GRAPHIC	VARCHAR	VAR-GRAPHIC					
SMALLINT	6	6	6	6					
INTEGER	11	11	11	11					
BIGINT	20	20	20	20					
DECIMAL (p,s)	2+p	2+p	2+p	2+p					
REAL	24	24	24	24					
DOUBLE	24	24	24	24					
DECFLOAT	42	42	42	42					
CHAR(n)								12	34
VARCHAR (n)	min(n,254)							12	34
CLOB(n)									
GRAPHIC (n)								12	34
VARGRAPHIC (n)								12	34
DBCLOB (n)									
BLOB(n)									
TIME	8	8	8	8					
DATE	10	10	10	10					
TIME-STAMP(p) WITHOUT TIME ZONE	If p=0 then 19, otherwise 20+p	If p=0 then 19, otherwise 20+p	If p=0 then 19, otherwise 20+p	If p=0 then 19, otherwise 20+p					
TIME-STAMP(p) WITH TIME ZONE	If p=0 then 148, otherwise 149+p	If p=0 then 148, otherwise 149+p	If p=0 then 148, otherwise 149+p	If p=0 then 148, otherwise 149+p					

Casting non-XML values to XML values

Table 26. Supported Casts from Non-XML Values to XML Values

Source Data Type	Target Data Type	
	XML	Resulting XML Schema Type
SMALLINT	Y	xs:short
INTEGER	Y	xs:int
BIGINT	Y	xs:long
DECIMAL	Y	xs:decimal
DECFLOAT	N	

Table 26. Supported Casts from Non-XML Values to XML Values (continued)

Source Data Type	Target Data Type	
	XML	Resulting XML Schema Type
REAL	N	
FLOAT	Y	xs:double
DOUBLE	Y	xs:double
CHAR	Y	xs:string
VARCHAR	Y	xs:string
CLOB	Y	xs:string
GRAPHIC	Y	xs:string
VARGRAPHIC	Y	xs:string
DBCLOB	Y	xs:string
BINARY	N	
VARBINARY	N	
BLOB	N	
character type FOR BIT DATA	N	
DATE	N	
TIME	N	
TIMESTAMP WITHOUT TIME ZONE	N	
TIMESTAMP WITH TIME ZONE	N	
ROWID	N	
distinct type	N	

When character string values are cast to XML values, the resulting xs:string atomic value cannot contain illegal XML characters. If the input character string is not in Unicode, the input characters are converted to Unicode.

Casting XML values to non-XML values

An XMLCAST from an XML value to a non-XML value can be described as two casts: an XQuery cast that converts the source XML value to a target XQuery data type that corresponds to the SQL target type, followed by a cast from the corresponding XQuery data type to the actual SQL type. The target XQuery data type is an XML schema data type like xs:decimal or xs:string, as shown in the follow table.

An XMLCAST is supported if the target type has a corresponding XQuery target type that is supported, and if there is a supported XQuery cast from the type of the source value to the corresponding XQuery target type. The target type that is used in the XQuery cast is based on the corresponding XQuery target type and might contain some additional restrictions.

The following table lists the XQuery types that result from such conversion.

Table 27. Supported Casts from XML Values to Non-XML Values

Target Data Type	Source Data Type	
	XML	Corresponding XQuery Target Type
SMALLINT	Y	xs:integer
INTEGER	Y	xs:integer
BIGINT	Y	xs:integer
DECIMAL	Y	xs:decimal
DECFLOAT	Y	xs:double
REAL	Y	xs:double
FLOAT	Y	xs:double
DOUBLE	Y	xs:double
CHAR	Y	xs:string
VARCHAR	Y	xs:string
CLOB	Y	xs:string
GRAPHIC	Y	xs:string
VARGRAPHIC	Y	xs:string
DBCLOB	Y	xs:string
BINARY	N	
VARBINARY	N	
BLOB	N	
character type FOR BIT DATA	N	
DATE	Y	xs:date
TIME	Y	xs:time
TIMESTAMP	Y	xs:dateTime
ROWID	N	
distinct type	N	

The following restrictions are in effect when a value is cast from an XQuery target data type to a target SQL data type:

- If the target type is one of the character or graphic string types, the resulting XML value is converted, if necessary, to the CCSID of the target data type using the rules described in "Conversion rules for string assignment" in ["String assignments"](#) on page 149, before it is converted to the target type with a limited length. Truncation occurs if the specified length limit is smaller than the length of the resulting string after CCSID conversion. A warning occurs if any non-blank characters are truncated. If the target type is a fixed-length string type (CHAR or GRAPHIC) and the specified length of the target type is greater than the length of the resulting string from CCSID conversion, blanks are padded at the end. This truncation and padding behavior is similar to retrieval assignment of character or graphic strings.
- If the target type is DOUBLE or REAL and the source XML value after the XQuery cast is an xs:double value of INF, -INF, or NaN, an error is returned. If the source value is an xs:double negative zero, the value is converted to positive zero. If the source value is beyond the range of the target data type, an overflow error is returned. If the source value contains more significant digits than the precision of the target data type, the source value is rounded to the precision of the target data type.

- If the target type is DECFLOAT and the source XML value is an xs:double value of INF, -INF, or NaN, the result will be the corresponding special DECFLOAT values INF, -INF, or NaN. If the source value is an xs:double negative zero, the result is negative zero. If the target type is DECFLOAT(16) and the source value is beyond the range of DECFLOAT(16), an overflow error is returned. If the source value has more than 16 significant digits, the value is rounded according to the ROUNDING mode that is in effect. This rounding behavior is the same as what is used during the cast of DECFLOAT(34) to DECFLOAT(16).
- If the target type is DECIMAL, the resulting xs:decimal value is converted, if necessary, to the precision and scale of the target data type. The necessary number of leading zeros is added or removed. In the fractional part of the number, the necessary number of trailing zeros is added or the necessary number of digits is eliminated. This truncation behavior is similar to the behavior of the cast from DECIMAL to DECIMAL.
- If the target type is DATE, TIME, or TIMESTAMP WITHOUT TIME ZONE, the resulting XML value is adjusted to UTC time and the time zone component is removed. If the source does not include a time zone and the target data type is TIMESTAMP WITH TIME ZONE, zeroes are used for the time zone component. If the target type is TIME and the resulting XML value contains a seconds component with non-zero digits after the decimal point, those digits are truncated. If the target type is DATE or timestamp, the year part of the resulting xs:date or xs:dateTime value must be in the range of 0001 to 9999. If the target type is timestamp and the precision of the target timestamp is less than 12, the fractional seconds part of the xs:dateTime value will be truncated to the target timestamp precision.

Implicit cast from numeric data to string data

When Db2 implicitly casts a numeric value to a string value, the target type is VARCHAR value which is then compatible with other character string or graphic string data types.

The length attribute and the CCSID attribute of the result of the cast are determined in the same way as the VARCHAR function. When GRAPHIC or VARGRAPHIC data types are involved, the encoding scheme must be UNICODE. The following table shows the target type and length:

<i>Table 28. Target type and length attribute for implicit cast from numeric types to string types</i>	
Source data type	Target data type
SMALLINT	VARCHAR(6)
INTEGER	VARCHAR(11)
BIGINT	VARCHAR(20)
NUMERIC or DECIMAL	VARCHAR(<i>precision</i> +2)
REAL	VARCHAR(24)
FLOAT	VARCHAR(24)
DOUBLE	VARCHAR(24)
DECFLOAT	VARCHAR(42)

Implicit conversion from a numeric value to a string value can happen during:

- Assignment (where the source value is a number and the target operand is a character string or graphic string data type).

Among assignment statements, implicit casting is not supported for the SET statements for special registers, the RETURNS clause and RETURN statement for functions, and the SQL control statements: RETURN, SIGNAL, and RESIGNAL.

- Application of concatenation operators (CONCAT and ||)
- Application of set operators.

Implicit conversion is not supported in the following cases:

- One operand of a set operator is a numeric value and the other operand is a string value

- A numeric value is compared to or assigned to a string value that is the result of a fullselect which included a set operator
- Assignment to a global variable that is the target of a SELECT INTO statement

Implicit cast from string data to numeric data

When Db2 implicitly casts a character string or graphic string value to a numeric value, the target type is DECFLOAT(34) which is compatible with other numeric data types.

When GRAPHIC or VARGRAPHIC data types are involved, the encoding scheme must be UNICODE. The following table shows the target type and length:

Source data type	Target data type
CHAR	DECFLOAT(34)
VARCHAR	DECFLOAT(34)
GRAPHIC	DECFLOAT(34)
VARGRAPHIC	DECFLOAT(34)
CHAR FOR BIT DATA or VARCHAR FOR BIT DATA	N/A
BINARY	N/A
VARBINARY	N/A
BLOB	N/A
CLOB	N/A
DBCLOB	N/A

Implicit conversion from a string value to a numeric value can happen during:

- Assignment (where the source value is a character string or graphic string and the target operand is a numeric data type).
- Comparisons

When a character string or graphic string value is compared with a numeric value, Db2 implicitly converts the string value to DECFLOAT(34) and applies numeric comparison rule between the DECFLOAT(34) value and the other numeric value.

- Basic predicates, quantified predicates, and DISTINCT predicates (one operand is numeric value and the other operand is character string or graphic string value)

Numeric is the dominant data type. The character or graphic string value is cast to DECFLOAT(34) value.

- BETWEEN predicates

Numeric is the dominant data type. If any of the three operands is a numeric value, Db2 implicitly casts the character or graphic string operands to DECFLOAT data type.

- IN predicates

Numeric is the dominant data type. If any of the operands is a numeric value, Db2 implicitly casts the character or graphic string operands to DECFLOAT data type.

- Searched-when-clause of CASE expression

Pair-wise comparison is performed. Implicit cast of each pair follows the same rule as for a basic predicate. Implicit string and numeric cast is supported on *searched-when-clause* of CASE expression.

- Search conditions in SQL control statements (one operand is numeric value and the other operand is character string or graphic string value)

The search condition can appear in SQL control statements like the CASE statement, the IF statement, the REPEAT statement, and the WHILE statement. For comparisons in the search condition, numeric is the dominant data type. The character string or graphic string value is cast to a DECFLOAT(34) value. Implicit string and numeric cast is supported on the *searched-when-clause* of the CASE statement.

- Arithmetic operators (unary arithmetic operators + and - and infix arithmetic operators +, -, *, and /)

If the operand of unary arithmetic operators is of a character string or graphic string data type, that operand is implicitly cast to DECFLOAT(34). For infix arithmetic operators, if one operand is a numeric value or both operands are character or graphic string values, Db2 implicitly casts the character string or graphic string operand to the DECFLOAT data type.

Implicit conversion is not supported in the following cases:

- One operand of a set operator is a string value and the other operand is a numeric value
- A string value is compared to or assigned to a numeric value that is the result of a fullselect which included a set operator
- For FULL OUTER JOIN when the join condition is between string and numeric data types
- Assignment to a global variable that is the target of a SELECT INTO statement

Assignment and comparison

The basic operations of SQL are assignment and comparison.

Assignment operations are performed during the execution of statements such as CALL, INSERT, UPDATE, MERGE, FETCH, SELECT INTO, SET *host-variable* or SET *assignment-statement*, and VALUES INTO statements. In addition, when a function is invoked or a stored procedure is called, the arguments of the function or stored procedure are assigned. Comparison operations are performed during the execution of statements that include predicates and other language elements such as MAX, MIN, DISTINCT, GROUP BY, and ORDER BY.

The basic rule for both operations is that data types of the operands must be compatible. The compatibility rule also applies to other operations that are described under [“Rules for result data types”](#) on page 166.

The following table shows the compatibility of data types for assignments and comparisons.

Table 30. Data Type Compatibility for Assignments and Comparisons

Operand	Binary integer	Decimal number	Floating point	Decimal floating point	Character string	Graphic string	Binary string	Date	Time	Timestamp without time zone	Timestamp with time zone	Row ID	User-defined type	XML ⁸ on page 145	
Binary integer	Yes	Yes	Yes	Yes	"1" on page 145	"1" on page 145	No	No	No	No	No	No	"2" on page 145	No	
Decimal number	Yes	Yes	Yes	Yes	"1" on page 145	"1" on page 145	No	No	No	No	No	No	"2" on page 145	No	
Floating point	Yes	Yes	Yes	Yes	"1" on page 145	"1" on page 145	No	No	No	No	No	No	"2" on page 145	No	
Decimal floating point	Yes	Yes	Yes	Yes	"1" on page 145	"1" on page 145	No	No	No	No	No	No	"2" on page 145	No	
Character string	"1" on page 145	"1" on page 145	"1" on page 145	"1" on page 145	Yes	Yes "3" on page 145 , "4" on page 145	No "5" on page 145	Yes "7" on page 145	Yes "7" on page 145	Yes "7" on page 145	Yes "7" on page 145	No	"2" on page 145	No	
Graphic string	"6" on page 145	"6" on page 145	"6" on page 145	"6" on page 145	Yes "3" on page 145 , "4" on page 145	Yes	No	"3" on page 145 , "7" on page 145	"3" on page 145 , "7" on page 145	"3" on page 145 , "7" on page 145	"3" on page 145 , "7" on page 145	No	"2" on page 145	No	
Binary string	No	No	No	No	No "5" on page 145	No	Yes	No	No	No	No	No	"2" on page 145	No	
Date	No	No	No	No	"7" on page 145	"3" on page 145 , "7" on page 145	No	Yes	No	No	No	No	"2" on page 145	No	
Time	No	No	No	No	"7" on page 145	"3" on page 145 , "7" on page 145	No	No	Yes	No	No	No	"2" on page 145	No	
Timestamp without time zone	No	No	No	No	"7" on page 145	"3" on page 145 , "7" on page 145	No	No	No	Yes	Yes	No	"2" on page 145	No	
Timestamp with time zone	No	No	No	No	"7" on page 145	"3" on page 145 , "7" on page 145	No	No	No	Yes	Yes	No	"2" on page 145	No	
Row ID	No	No	No	No	No	No	No	No	No	No	No	Yes	"2" on page 145	No	
User-defined type	"2" on page 145	"2" on page 145	"2" on page 145	"2" on page 145	"2" on page 145	"2" on page 145	"2" on page 145	"2" on page 145	"2" on page 145	"2" on page 145	"2" on page 145	"2" on page 145	"2" on page 145	Yes "2" on page 145	No
XML ⁸ on page 145	No	No	No	No	No	No	No	No	No	No	No	No	No	Yes	

Table 30. Data Type Compatibility for Assignments and Comparisons (continued)

Operand	Binary integer	Decimal number	Floating point	Decimal floating point	Character string	Graphic string	Binary string	Date	Time	Timestamp without time zone	Timestamp with time zone	Row ID	User-defined type	XML ⁸ on page 145
<p>1. LOBs and bit data are not supported.</p> <p>2. The compatibility rules for user-defined types are as follows:</p> <ul style="list-style-type: none"> • A user-defined distinct type value is only comparable to a value that is defined with the same user-defined distinct type. In general, assignments are supported between a distinct type value and its source data type. • A user-defined array type value is only comparable to a value that is defined with the same user-defined array type. <p>This means that in general, an ordinary array type is not compatible with an associative array type. The following exceptions apply only to a CALL statement for a remote stored procedure:</p> <ul style="list-style-type: none"> – A source value that is an ordinary array with an integer index can be specified for a target that is defined as an associative array, if the definitions of the array elements of the two arrays are compatible. Db2 transforms the ordinary array into an associative array with an integer index, preserving the ordering of the elements in the original ordinary array. However, if the associative array is defined with a VARCHAR index, an SQL error code is returned. – A source value that is an associative array can be specified for a target defined as an ordinary array. Db2 transforms the associative array into an ordinary array, by assigning the values of the array elements in the associative array in the same order in the target ordinary array, and assigning appropriate index values. <p>For additional information, see “User-defined type assignments” on page 153.</p> <p>3. On assignment and comparison from Graphic to Character, the resulting length in bytes is $3 * (\text{LENGTH}(\text{graphic-string}))$, depending on the CCSIDs.</p> <p>4. Character strings with subtype FOR BIT DATA are not compatible with Graphic Data.</p> <p>5. All character strings, even those with subtype FOR BIT DATA, are not compatible with binary strings.</p> <p>6. LOBs are not supported.</p> <p>7. The compatibility of datetime and string values is subject to the following considerations:</p> <ul style="list-style-type: none"> • Datetime values can be assigned to string columns and to string variables that are not LOB values. • A valid string representation of a datetime value can be assigned to a datetime column or variable, or be compared to a datetime value, as explained in “Datetime assignments” on page 151. <p>In some situations an assignment of a string value to a datetime variable might not be supported, such as in the following examples:</p> <ul style="list-style-type: none"> • An assignment of a string representation of a datetime value to a datetime host variable. • An assignment in SQL PL when a datetime SQL variable or SQL parameter is the target of a SELECT INTO statement after a SET CURRENT PACKAGESET statement is issued. <p>8. Character and graphic strings, including LOBs, can be assigned to XML columns. For comparison, XML can only be compared using the XMLEXISTS and NULL predicates.</p>														

Compatibility with a column that has a field procedure is determined by the data type of the column, which applies to the decoded form of its values.

A basic rule for assignment operations is that a null value cannot be assigned to:

- A column that cannot contain null values
- A non-Java host variable that does not have an associated indicator variable

For a host variable that does have an associated indicator variable, a null value is assigned by setting the indicator variable to a negative value. See [“Host variables” on page 227](#) for a discussion of indicator variables.

- A Java host variable that is a primitive type

For a Java host variable that is not a primitive type, the value of that variable is set to a Java null value.

Numeric assignments

The basic rule for numeric assignments is that the whole part of a decimal or integer number cannot be truncated. If necessary, the fractional part of a decimal number is truncated.

Decimal or integer to floating-point

Because floating-point numbers are only approximations of real numbers, the result of assigning a decimal or integer number to a floating-point column or variable might not be identical to the original number.

Floating-point or decimal to integer

When a single precision floating-point number is converted to integer, rounding occurs on the seventh significant digit, zeros are added to the end of the number, if necessary, starting from the seventh significant digit, and the fractional part of the number is eliminated. When a double precision floating-point or decimal number is converted to integer, the fractional part of the number is eliminated.

The following example shows single precision floating-point numbers converted to an integer:

Floating-point number:	Results when assigned to an integer column or host variable:
2.0000045E6	2000000
2.00000555E8	200001000

The following example shows a double precision floating-point number converted to an integer:

Floating-point number:	Results when assigned to an integer column or host variable:
2.0000045E6	2000004
2.00000555E8	200000555

The following example shows a decimal number converted to an integer:

Decimal number:	Results when assigned to an integer column or host variable:
2000004.5	2000004
200000555.0	200000555

Decimal to decimal

When a decimal number is assigned to a decimal column or variable, the number is converted, if necessary, to the precision and the scale of the target.

The necessary number of leading zeros is added or eliminated, and, in the fractional part of the number, the necessary number of trailing zeros is added, or the necessary number of trailing digits is eliminated.

Decimal to DECFLOAT

When a decimal number is assigned to a DECFLOAT column or variable, the number is converted to the precision (16 or 34) of the target. Leading zeros are eliminated.

Depending on the precision and scale of the decimal number, and the precision of the target, the value might be rounded to fit.

For static SQL statements other than CREATE VIEW, the ROUNDING bind option or the native SQL procedure option determines the rounding mode.

For dynamic SQL statements (and static CREATE VIEW statements), the special register CURRENT DECFLOAT ROUNDING MODE determines the rounding mode.

Integer to decimal

When an integer is assigned to a decimal column or variable, the number is converted first to a temporary decimal number and then, if necessary, to the precision and scale of the target.

The precision and scale of the temporary decimal number is 5,0 for a small integer, 11,0 for a large integer, or 19,0 for a big integer.

Integer to DECFLOAT

When an integer is assigned to a DECFLOAT column or variable, the number is converted first to a temporary decimal number and then to DECFLOAT.

The precision and scale of the temporary decimal number is 5,0 for a small integer, 11,0 for a large integer, or 19,0 for a big integer. The decimal number is then converted to DECFLOAT using the rules for Decimal to DECFLOAT. See [“Decimal to DECFLOAT” on page 146](#).

Floating-point to floating-point

When a single precision floating-point number is assigned to a double precision floating-point column or variable, the single precision data is padded with eight hex zeros. When a double precision floating-point

number is assigned to a single precision floating-point column or variable, the double precision data is converted and rounded up on the seventh hex digit.

In assembler, C, or C++ applications that are prepared with the FLOAT(IEEE) SQL processing option, floating-point constants and values in host variables are assumed to have IEEE floating-point format. All floating-point data is stored in Db2 in System/390 floating-point format.

Therefore, when the FLOAT(IEEE) SQL processing option is in effect, Db2 performs the following conversions:

- When a number in short or long IEEE floating-point format is assigned to a single-precision or double-precision floating-point column, Db2 converts the number to System/390 floating-point format.
- When a single-precision or double-precision floating-point column value is assigned to a short or long floating-point host variable, Db2 converts the column value to IEEE floating-point format.

Floating-point to decimal

When a single precision floating-point number is assigned to a decimal column or variable, the number is first converted to a temporary decimal number.

When a single precision floating-point number is assigned to a decimal column or variable, the number is first converted to a temporary decimal number of precision 6 by rounding on the seventh decimal digit. Twenty five zeros are then appended to the number to bring the precision to 31. Because of rounding, a number less than 0.5×10^{-6} is reduced to 0.

When a double precision floating-point number is assigned to a decimal column or variable, the number is first converted to a temporary decimal number of precision 15, and then, if necessary, truncated to the precision and scale of the target. In this conversion, zeros are added to the end of the number, if necessary, to bring the precision to 16. The number is then rounded (using floating-point arithmetic) on the sixteenth decimal digit to produce a 15-digit number. Because of rounding, a number less in magnitude than 0.5×10^{-15} is reduced to 0. If the decimal number requires more than 15 digits to the left of the decimal point, an error is reported. Otherwise, the scale is given the largest possible value that allows the whole part of the number to be represented without loss of significance.

The following examples show the effect of converting a double precision floating-point number to decimal:

- The floating-point number, `.123456789098765E-05` in decimal notation is, `.00000123456789098765`. Rounding adds 5 in the 16th position, so the number becomes `.00000123456789148765` and truncates the result to `.000001234567891`. Zeros are then added to the end of a 31-digit result, and the number becomes `.00000123456789100000000000000000`.
- The floating-point number, `1.233999999999999E+01` in decimal notation is, `12.33999999999900`. Rounding adds 5 in the 16th position, so the number becomes `12.33999999999905` and truncates the result to `12.3399999999990`. Zeros are then added to the end of a 31-digit result and the number becomes `12.33999999999900000000000000000000`.

Floating point to DECFLOAT

When a single or double precision floating-point number is assigned to a DECFLOAT column or variable, the number is first converted to a temporary string representation of the floating point number. The string representation of the number is then converted to DECFLOAT.

DECFLOAT to integer

When a DECFLOAT is assigned to a binary integer column or variable, the fractional part of the number is lost.

The following example shows decimal floating-point numbers converted to an integer:

Decimal floating-point number:	Results when assigned to an integer column or host variable:
--------------------------------	--

2.0000045E6
2.00000555E8

2000004
200000555

DECFLOAT to decimal

When a DECFLOAT value is assigned to a decimal column or variable, the DECFLOAT value is converted, if necessary, to the precision and the scale of the target.

During the assignment, the necessary number of leading zeros is added and, in the fractional part of the number, the necessary number of trailing zeros is added, or rounding occurs.

For static SQL statements other than CREATE VIEW, the ROUNDING bind option or the native SQL procedure option determines the rounding mode.

For dynamic SQL statements (and static CREATE VIEW statements), the special register CURRENT DECFLOAT ROUNDING MODE determines the rounding mode.

The following example shows decimal floating-point numbers converted to a decimal value:

Decimal floating-point number:	Results when assigned to an decimal(15,0) column or host variable:
2.0000045E6	2000005
Decimal floating-point number:	Results when assigned to an decimal(15,2) column or host variable:
2.0000045E6	2000004.50
2.00000555E8	200000555.00

DECFLOAT to floating-point

Because floating-point numbers are only approximations of real numbers, the result of assigning a DECFLOAT value to a floating-point column or variable might not be identical to the original number.

The DECFLOAT value is first converted to a string representation, and is then converted to floating-point number.

DECFLOAT(16) to DECFLOAT(34)

When a DECFLOAT(16) is assigned to a DECFLOAT(34) column or variable, the exponent of the source is converted to the corresponding exponent in the result format, and the coefficient is extended by appending zeros on the left.

DECFLOAT(34) to DECFLOAT(16)

When a DECFLOAT(34) is assigned to a DECFLOAT(16) column or variable, the exponent of the source is converted to the corresponding exponent in the result format.

The source coefficient is rounded to the precision of the target.

For static SQL statements, the ROUNDING bind option or the native SQL procedure option determines the rounding mode.

For static SQL statements other than CREATE VIEW, the ROUNDING bind option or the native SQL procedure option determines the rounding mode.

For dynamic SQL statements (and static CREATE VIEW statements), the special register CURRENT DECFLOAT ROUNDING MODE determines the rounding mode.

To COBOL integers

Assignment to COBOL integer variables uses the full size of the integer.

Thus, the value placed in the COBOL data item might be out of the range of values.

COBOL supports some data types with no SQL equivalent (BINARY decimal and DISPLAY decimal data items, for example). In most cases, you can use COBOL statements to convert between the unsupported COBOL data types and the data types that SQL supports.

For Db2 for z/OS, the only BINARY numeric variables allowed as HOST variable are integer binary variables. The only DECIMAL host variables supported by SQL are packed decimal host variables.

For example, if COL1 contains a value of 12345, the following statements cause the value 12345 to be placed in A, even though A has been defined with only 4 digits:

```
01 A PIC S9999 BINARY.  
EXEC SQL SELECT COL1  
        INTO :A  
        FROM TABLEX  
END-EXEC.
```

The following example COBOL statement results in 2345 being placed in A:

```
MOVE 12345 TO A.
```

String assignments

There are two types of string assignments; storage assignment and retrieval assignment.

- *Storage assignment* is when a value is assigned to a column or to a transition variable.
- *Retrieval assignment* is when a value is assigned to a variable, except for a transition variable.

The rules differ for storage and retrieval assignment.

Binary string assignment

Binary string assignment involves assignment at both the storage and the retrieval of binary strings.

Storage assignments

The length of a string that is assigned to a column or transition variable must not be greater than the length attribute of the column or parameter. If the string is longer than the length attribute of that column or transition variable, an error is returned.

When the string is assigned to a fixed-length binary string column or parameter of a function or procedure, and the length of the string is less than the length attribute of that column or parameter, the string is padded to the right with the necessary number of binary zeros.

Retrieval assignments

The length of a string that is assigned to a variable can be greater than the length attribute of the variable. When a string is assigned to a variable and the string is longer than the length attribute of the variable, the string is truncated on the right by the necessary number of bytes. When this occurs, a warning is returned.

Character and graphic string assignment

The rules for storage and retrieval assignment apply when both the source and the target are strings.

When a datetime data type is involved, see [“Datetime assignments” on page 151](#). For the special considerations that apply when a distinct type is involved in an assignment, especially to a variable, see [“Distinct type assignments” on page 153](#).

Storage assignment for character and graphic strings

The basic rule for character storage assignment is that the length of a string that is assigned to a column or transition variable must not be greater than the length attribute of the column or transition variable.

Trailing blanks are included in the length of the string. When the length of the string is greater than the length attribute of the column or the parameter, the following actions occur:

- If all of the trailing characters that must be truncated to make a string fit the target are blanks and the string is a character or graphic string, the string is truncated and assigned without warning.
- Otherwise, the string is not assigned and an error occurs to indicate that at least one of the excess characters is non-blank.

When a string is assigned to a fixed-length column or parameter and the length of the string is less than the length attribute of the target, the string is padded to the right with the necessary number of SBCS or DBCS blanks. The pad character is always a blank even for columns or parameters that are defined with the FOR BIT DATA attribute.

Retrieval assignment for character and graphic strings

The length of a string that is assigned to a variable can be greater than the length attribute of the variable. When the length of the string is greater than the length of the variable, the string is truncated on the right by the necessary number of SBCS or DBCS characters.

When truncation occurs, a warning is returned (SQLSTATE of '01004'). If the variable is a host variable, the value 'W' is assigned to the SQLWARN1 field of the SQLCA. Furthermore, if an indicator variable is provided and the source of the value is not a LOB, the indicator variable is set to the original length of the string. The truncation result of an improperly formed mixed string is unpredictable.

When a character string is assigned to a fixed-length variable and the length of the string is less than the length attribute of the target, the string is padded to the right with the necessary number of blanks. The pad character is always a blank even for strings defined with the FOR BIT DATA attribute.

When a string of length n is assigned to a varying-length string variable with a maximum length greater than n , the characters after the n th character of the variable are undefined.

Assignments involving mixed data strings

A mixed data string that contains MBCS characters cannot be assigned to an SBCS column, SBCS parameter, or SBCS variable.

The following rules apply when a mixed data string is assigned to a variable and the string is longer than the length attribute of the variable:

- If the string is not well-formed mixed data, it is truncated as if it were BIT or graphic data.
- If the string is well-formed mixed data, it is truncated on the right such that it is well-formed mixed data with a length that is the same as the length attribute of the variable and the number of characters lost is minimal.

Assignments involving C NUL-terminated strings

A C NUL-terminated string variable that is referenced in a CONNECT statement does not need to contain a NUL. Otherwise, Db2 enforces the convention that the value of a NUL-terminated string variable, either character or graphic, is NUL-terminated.

An input variable that does not contain a NUL will cause an error. A value that is assigned to an output variable will always be NUL-terminated even if a character must be truncated to make room for the NUL.

When a string of length n is assigned to a C NUL-terminated string variable with a length greater than $n+1$, the rules depend on whether the source string is a value of a fixed-length string or a varying-length string:

- If the source is a fixed-length string and the value of field PAD NUL-TERMINATED on installation panel DSNTIP4 is YES, the string is padded on the right with $x-n-1$ blanks, where x is the length of the variable. The padded string is then assigned to the variable and a NUL is appended at the end of the variable. If the value of field PAD NUL-TERMINATED is NO, the string is assigned to the first n bytes of the variable and a NUL is appended at the end of the variable.
- If the source is a varying-length string, the string is assigned to the first n bytes of the variable and a NUL is appended at the end of the variable.

Conversion rules for string assignment

A character or graphic string that is assigned to a column or variable is first converted, if necessary, to the coded character set of the target. Conversion is necessary only if certain conditions apply.

Conversion is necessary only if all the following conditions are true:

- The CCSIDs of string and target are different.
- Neither CCSID is X'FFFF' (neither the string nor the target is defined as BIT data).
- The string is neither null nor empty.

An error occurs if:

- The SYSSTRINGS table is used but contains no information about the pair of CCSIDs and Db2 cannot do the conversion through z/OS support for Unicode.
- A character of the string cannot be converted and the operation is assignment to a column or to a host variable that has no indicator variable. For example, a DBCS character cannot be converted to a variable with an SBCS CCSID.

A warning occurs if:

- A character of the string is converted to a substitution character. A *substitution character* is the character that is used when a character of the source character set is not part of the target character set. For example, assuming an EBCDIC target character set, if the source character set includes Katakana characters and the target character set does not, a Katakana character is converted to the EBCDIC SUB X'3F'.
- A character of the string cannot be converted and the operation is assignment to a variable that has an indicator variable. For example, a DBCS character cannot be converted if the variable has an SBCS CCSID. In this case, the string is not assigned to the variable and the indicator variable is set to -2.

Datetime assignments

A string value that is assigned to a date, time, or timestamp column, variable, or parameter must be a valid string representation of a date, a time, or a timestamp.

A value that is assigned to a date column, a date variable, or a date parameter must be a date, a valid string representation of a date, or a valid string representation of a timestamp without a time zone. When a string representation of a timestamp without a time zone is assigned to a date target, the Db2 database manager assigns the date portion of the timestamp to the date target, and does not use the time portion of the timestamp.

A date can be assigned only to the following items:

- a date column
- a character-string column
- a character-string variable
- a date variable

A value that is assigned to a time column, a time variable, or a time parameter must be a time, a valid string representation of a time, or a valid string representation of a timestamp without a time zone. When a string representation of a timestamp without a time zone is assigned to a time target, the Db2 database manager assigns the time portion of the timestamp to the time target, truncates any fractions of seconds, and does not use the date portion of the timestamp.

A time can be assigned only to the following items:

- a time column
- a character-string column
- a character-string variable
- a time variable

A value that is assigned to a timestamp column, a timestamp variable, or a timestamp parameter must be a timestamp, a timestamp constant, a valid string representation of a timestamp, or a valid string representation of a date. When a string representation of a date is assigned to a timestamp target, the Db2 database manager inserts zeroes for the time portion of the timestamp target.

A timestamp can be assigned only to the following items:

- a timestamp column
- a character-string or graphic-string column
- a timestamp variable
- a character-string or graphic-string variable

A valid string representation of a datetime value must not be a BLOB, CLOB, or DBCLOB. A datetime value cannot be assigned to a column that has a field procedure. If the timestamp precision of the target is less than the timestamp precision of the assigned value, the extra fractional seconds are truncated.

When a datetime value is assigned to a character-string variable or column, it is converted to its string representation. Leading zeros are not omitted from any part of the date, time, or timestamp. The required length of the target varies depending on the format of the string representation. If the length of the fixed length character-string target is greater than required, it is padded on the right with blanks. If the length of the target is less than required, the result depends on the type of datetime value involved, and the type of the target.

When a datetime value is assigned to a timestamp variable or column, it is converted to the target timestamp data type. If the source data type is not the same as the target data type, the source value is implicitly cast to the target data type. Db2 might implicitly cast data types during assignments that involve a distinct type.

- If the target is not a variable and has a character-string or graphic-string data type (except for BLOB, CLOB, or DBCLOB), truncation is not allowed. The length of the column must be at least the following values:
 - 10 for a **DATE**
 - 8 for a **TIME**
 - 19 for a **TIMESTAMP WITHOUT TIME ZONE** with a precision of 0, $20+p$ with precision of p
 - Sufficient to include the time zone (truncation is not allowed), for a **TIMESTAMP WITH TIME ZONE**
- When the target is a character-string or graphic-string variable, the following rules apply:
 - **For a date:** The length of the variable must not be less than 10.
 - **For a time:** If the USA format is used, the length of the variable must not be less than 8. This format does not include seconds.

If the ISO, EUR, or JIS format is used, the length of the variable must not be less than 5. If the length is 5, 6, or 7, the seconds part of the time is omitted from the result and SQLWARN1 is set to 'W'. In this case, the seconds part of the time is assigned to the indicator variable if one is provided, and, if the length is 6 or 7, the value is padded with blanks so that it is a valid string representation of a time.
 - **For a timestamp:** The length of the variable must not be less than 19. If the source is **TIMESTAMP WITH TIME ZONE**, the length of the variable must be sufficient to include the time zone, truncation is not allowed.
 - If the length is in the range 19–31, the timestamp is truncated like a string, which causes the omission of one or more digits of the fractional seconds part of a timestamp.
 - If the length is 20, the trailing decimal point is excluded so that the value is a valid string representation of a timestamp with precision 0.

Row ID assignments

A row ID value can be assigned only to a column, parameter, or host variable with a row ID data type.

For the value of the ROWID column, the column must be defined as GENERATED BY DEFAULT and the column must have a unique, single-column index. The value that is specified for the column must be a valid row ID value that was previously generated by Db2.

XML assignments

XML data can be assigned to a column, but when the target is not a column, the XML data type can only be assigned to another XML data type.

When the target is a column (for example, data change statements), the source can be the XML data type, or CHAR, VARCHAR, CLOB, GRAPHIC, VARGRAPHIC, DBCLOB, BINARY, VARBINARY, or BLOB data types. When the source is not XML data, the source is implicitly parsed as if the XMLPARSE function is invoked with the STRIP WHITESPACE option. If the source data is graphic data, the encoding scheme must be Unicode.

All other data types cannot be assigned to a target of the XML data type.

User-defined type assignments

User-defined type assignments include distinct type assignments and array assignments.

Distinct type assignments

The rules that apply to the assignments of distinct types to host variables are different than the rules for all other assignments that involve distinct types.

Assignments to host variables: The assignment of distinct type to a host variable is based on the source data type of the distinct type. Therefore, the value of a distinct type is assignable to a host variable only if the source data type of the distinct type is assignable to the host variable.

Example: Assume that distinct type AGE was created with the following SQL statement:

```
CREATE TYPE AGE AS SMALLINT;
```

When the statement was executed, Db2 also generated these cast functions:

```
AGE (SMALLINT) RETURNS AGE
AGE (INTEGER) RETURNS AGE
SMALLINT (AGE) RETURNS SMALLINT
```

Next, assume that column STU_AGE was defined in table STUDENTS with distinct type AGE. Now, consider this valid assignment of a student's age to host variable *HV_AGE*, which has an INTEGER data type:

```
SELECT STU_AGE INTO :HV_AGE FROM STUDENTS WHERE STU_NUMBER = 200;
```

The distinct type value is assignable to host variable *HV_AGE* because the source data type of the distinct type (SMALLINT) is assignable to the host variable (INTEGER). If distinct type AGE had been based on a character data type such as CHAR(5), the above assignment would be invalid because a character type cannot be assigned to an integer type.

Assignments other than to host variables: A distinct type can be the source or target of an assignment. Assignment is based on whether the data type of the value to be assigned is castable to the data type of the target. (“Casting between data types” on page 130 shows which casts are supported when a distinct type is involved). Therefore, a distinct type value can be assigned to any target other than a host variable when:

- The target of the assignment has the same distinct type, or
- The distinct type is castable to the data type of the target

Any value can be assigned to a distinct type when:

- The value to be assigned has the same distinct type as the target, or
- The data type of the assigned value is castable to the target distinct type

For examples, assume that the source data type for distinct type AGE is SMALLINT:

```
CREATE TYPE AGE AS SMALLINT;
```

Next, assume that two tables TABLE1 and TABLE2 were created with four identical column descriptions:

```
AGECOL  AGE
SMINTCOL SMALLINT
INTCOL  INTEGER
DECCOL  DEC(6,2)
```

Using the following SQL statement and substituting various values for X and Y to insert values into various columns of TABLE1 from TABLE2, the following table shows whether the assignments are valid. Db2 uses assignment rules in this INSERT statement to determine if X can be assigned to Y.

```
INSERT INTO TABLE1 (Y)
  SELECT X FROM TABLE2;
```

Table 31. Assessment of various assignments for example INSERT statement

X (column in TABLE2)	Y (column in TABLE1)	Valid	Reason
AGECOL	AGECOL	Yes	Source and target are same distinct type
SMINTCOL	AGECOL	Yes	SMALLINT can be cast to AGE
INTCOL	AGECOL	Yes	INTEGER can be cast to AGE (because AGE's source type is SMALLINT)
DECCOL	AGECOL	No	DECIMAL cannot be cast to AGE
AGECOL	SMINTCOL	Yes	AGE can be cast to its source type of SMALLINT
AGECOL	INTCOL	No	AGE cannot be cast to INTEGER
AGECOL	DECCOL	No	AGE cannot be cast to DECIMAL

Array type assignments

An array value can only be assigned to a variable or parameter with a compatible user-defined array type.

The following values can be assigned to an array variable:

- The null value.
- The value of an array with a user-defined array type, where the source and target arrays have the same user-defined array type. The source value can be an array variable, an invocation of the TRIM_ARRAY function, an invocation of the ARRAY_DELETE function, or a CAST specification. The value of an ordinary array variable or parameter can only be assigned to an ordinary array target. The value of an associative array variable or parameter can only be assigned to an associative array target.
- The value of an array without a user-defined array type. The result of an invocation of aggregate built-in function ARRAY_AGG or of an array constructor is an array without an associated user-defined data type.

For an assignment with a FETCH statement, the elements in the source array value must have the same data type as the elements of the user-defined array type of the target array. The index values of the

source array value must have the same data type as the index of the user-defined array type of the target array.

For an assignment that is the result of a statement other than FETCH, the source array value is implicitly cast to the target array type.

Assignment of a value to an array element might affect the cardinality of the array, and might result in initializing other new array elements with the null value. Suppose that *A* is the target array variable, *c* is the cardinality of array *A*, *idx* is an expression that is used as the array index, and *SV* is the source value. Db2 assigns the values to the elements of the array as follows:

- If array *A* is the null value, *A* is set to an empty array.
- If *A* is an ordinary array:
 - If *idx* is less than or equal to *c*, the value in the element of *A* with array index *idx* is replaced by the value of *SV*.
 - If *idx* greater than *c*:
 - Each element of *A* with array index *i*, for every *i* that is greater than *c* and less than *idx*, is set to the null value.
 - The element of *A* with array index *idx* is set to the value of *SV*.
 - The cardinality of *A* is set to *idx*.
- If *A* is an associative array:
 - If *idx* matches an existing value of the array index for *A*, the value of the element with array index *idx* is replaced by the value of *SV*.
 - If *idx* does not match an existing value of the array index for *A*:
 - The element of *A* with array index *idx* is set to the value of *SV*.
 - The cardinality of *A* is incremented by 1.

The following values can be assigned to an element of an array variable:

- The null value
- The value of an expression, where the data type of the expression is assignable to the data type of the elements in the target array

Example: Assigning an array to another array

Suppose that arrays PHONELIST and HOMEPHONELIST are defined with the same user-defined array type named PLIST. PLIST is defined with VARCHAR(12) elements. The following statement assigns the values of the HOMEPHONELIST array to the PHONELIST array:

```
SET PHONELIST = HOMEPHONELIST;
```

Example: Assigning elements of an array to another array

Suppose that array *V* is defined with user-defined type MYARRAY. The following statement assigns the values 1, 2, and 3 to array *V* using an array constructor.

```
SET V = ARRAY[1,2,3];
```

This statement is equivalent to the following statement:

```
SET V = CAST(ARRAY[1,2,3] AS MYARRAY);
```

Example: Assigning values from a column to an array

Suppose that array *V* is defined with user-defined type MYARRAY. The following statement assigns the values from the column *C1* in table *T* to array *V* using the ARRAY_AGG function.

```
SELECT ARRAY_AGG(C1) INTO V FROM T;
```

This statement is equivalent to the following statement:

```
SELECT CAST (ARRAY_AGG(C1) AS MYARRAY) INTO V FROM T;
```

Assignments to LOB locators

When a LOB locator is used, it can refer only to LOB data. If a LOB locator is used for the first fetch of a cursor, LOB locators must be used for all subsequent fetches.

Numeric comparisons

Numbers are compared algebraically, that is, with regard to sign. For example, -2 is less than +1. When numbers of different data types are compared, certain rules are in effect as to how the comparison is performed.

If one number is an integer and the other is decimal, the comparison is made with a temporary copy of the integer, which has been converted to decimal.

When decimal numbers with different scales are compared, the comparison is made with a temporary copy of one of the numbers that has been extended with trailing zeros so that its fractional part has the same number of digits as the other number.

If one number is double precision floating-point and the other is integer, decimal, or single precision floating-point, the comparison is made with a temporary copy of the other number which has been converted to double precision floating-point. However, if a single precision floating-point number is compared with a floating-point constant, the comparison is made with a single precision form of the constant.

Two floating-point numbers are equal only if the bit configurations of their normalized forms are identical.

If one number is DECFLOAT and the other number is integer, decimal, single precision floating-point, or double precision floating-point, the comparison is made with a temporary copy of the other number which has been converted to DECFLOAT.

If one number is DECFLOAT(16) and the other number is DECFLOAT(34), the DECFLOAT(16) value is converted to DECFLOAT(34) before the comparison.

Additionally, the DECFLOAT data type supports both positive and negative zero. Positive and negative zero have different binary representations, but the equal (=) predicate will return true for comparisons of positive and negative zero.

The functions, COMPARE_DECFLOAT and TOTALORDER can be used to perform comparisons at a binary level. For example, for a comparison of 2.0<>2.00.

The DECFLOAT data type also supports the specification of negative and positive NaN (quiet and signaling), and negative and positive infinity. From an SQL perspective, infinity = infinity, NaN = NaN, and sNaN = sNaN.

The following rules are the comparison rules for these special values:

- Infinity compares equal only to infinity of the same sign (positive or negative)
- NaN compares equal only to NaN of the same sign (positive or negative)
- sNaN compares equal only to sNaN of the same sign (positive or negative)

The ordering among the different special values is as follows: -NAN < -SNAN < -INFINITY < 0 < INFINITY < SNAN < NAN

String comparisons

String comparisons can occur with binary string, character strings, and graphic strings.

Binary string comparisons

Binary string comparisons are always performed according to the binary values.

Two binary strings are equal only if the lengths of the two strings are identical. If the strings are equal up to the length of the shorter string length, the shorter string is considered less than the longer string even when the remaining bytes in the longer string are hexadecimal zeros. This is illustrated in the following table:

Table 32. Binary string comparison where one operand is longer because of hexadecimal zeros

Hexadecimal value of the first operand	relationship	Hexadecimal value of the second operand
X'4100'	<	X'410000'
X'4100'	<	X'42'
X'4100'	=	X'4100'
X'4100'	>	X'41'
X'4100'	>	X'400000'

Binary strings cannot be compared to character strings (even FOR BIT DATA) unless the character string is cast to a binary string.

Character and graphic string comparisons

Two strings are compared by comparing the corresponding bytes of each string. If the strings do not have the same length, the comparison is made with a temporary copy of the shorter string that has been padded on the right with blanks so that it has the same length as the other string.

Two strings are equal if they are both empty or if all corresponding bytes are equal. An empty string is equal to a blank string. If two strings are not equal, their relationship (that is, which has the greater value) is determined by the comparison of the first pair of unequal bytes from the left end of the strings. This comparison is made according to the collating sequence associated with the encoding scheme of the data. For ASCII data, characters A through Z (both upper and lowercase) have a greater value than characters 0 through 9. For EBCDIC data, characters A through Z (both upper and lowercase) have a lesser value than characters 0 through 9.

Varying-length strings with different lengths are equal if they differ only in the number of trailing blanks. In operations that select one value from a collection of such values, the value selected is arbitrary. The operations that can involve such an arbitrary selection are DISTINCT, MAX, MIN, and references to a grouping column. See the description of GROUP BY for further information about the arbitrary selection involved in references to a grouping column.

For more information, see [Objects with different CCSIDs in the same SQL statement \(Db2 Internationalization Guide\)](#).

String comparisons with field procedures

The rules for string comparisons with field procedures depend on the values being compared. If a column with a field procedure is compared with the value of a variable or a constant, the variable or constant is encoded by the field procedure before the comparison is made. If the comparison operator is LIKE, the variable or constant is not encoded and the column value is decoded.

If a column with a field procedure is compared with another column, that column must have the same field procedure and both columns must have the same CCSID set. The comparison is performed on the encoded form of the values in the columns. If the encoded values are numeric, their data types must be identical; if they are strings, their data types must be compatible.

If two encoded strings of different lengths are compared, the shorter is temporarily padded with encoded blanks so that it has the same length as the other string.

In a CASE expression, if a column with a field procedure is used as the *result-expression* in a THEN or ELSE clause, all other columns that are used as *result-expressions* must have the same field procedure. Otherwise, no column used in a *result-expression* can name a field procedure.

Datetime comparisons

A date, time, or timestamp value can be compared with another value of the same data type, a datetime constant of the same data type, or with a string representation of a value of that data type. Additionally, a `TIMESTAMP WITHOUT TIME ZONE` value can be compared with a `TIMESTAMP WITH TIME ZONE` value.

All comparisons are chronological, which means the further a point in time is from January 1, 0001, the greater the value of that point in time. The time 24:00:00 compares greater than the time 00:00:00.

Comparisons that involve `TIME` values and string representations of time values always include seconds. If the string representation omits seconds, zero seconds are implied.

Comparisons that involve timestamp values are evaluated according to the following rules:

- When comparing timestamp values with different precisions, the higher precision is used for the comparison and any missing digits for fractional seconds are assumed to be zero.
- When comparing a `TIMESTAMP WITH TIME ZONE` value to a `TIMESTAMP WITHOUT TIME ZONE` value, the `TIMESTAMP WITHOUT TIME ZONE` value is cast to `TIMESTAMP WITH TIME ZONE` before the comparison is made.
- When comparing two `TIMESTAMP WITH TIME ZONE` values, the comparison is made using the UTC representations of the values. Two `TIMESTAMP WITH TIME ZONE` values are considered equal if they represent the same instance in UTC, regardless of the time zone offsets that are stored in the values. For example, '1999-04-15-08.00.00-08:00' (8:00 a.m. Pacific Standard Time) is the same as '1999-04-15-11.00.00-05:00' (11:00 a.m. Eastern Standard Time).
- When comparing a timestamp value with a string representation of a timestamp, the string representation is first converted to the data type of the timestamp operand. With the exception that the converted value has a precision of 12. If the timestamp operand is `TIMESTAMP WITHOUT TIME ZONE`, the string must not contain a specification of time zone.
- Timestamp comparisons are chronological without regard to representations that might be considered equivalent. For example, the following predicate is true:

```
TIMESTAMP('1990-02-23-00.00.00') > '1990-02-22-24.00.00'
```

Example 1: Table `TABLE1` has 2 columns: `C1`, which is defined as `TIMESTAMP WITH TIME ZONE`; and `C2`, which is defined as `TIMESTAMP WITHOUT TIME ZONE`:

```
CREATE TABLE TABLE1 (C1 TIMESTAMP WITH TIME ZONE, C2 TIMESTAMP);
```

A row is inserted into the table with the following `INSERT` statement. The input values are provided by character-string representations of a timestamp with a time zone.

```
INSERT INTO TABLE1 VALUES ( '2007-11-05-08.00.00-08:00', '2007-11-05-08.00.00');
```

Assuming that the implicit time zone is `-5:00`, the following `SELECT` statement will not return any rows. The string representation of the `TIMESTAMP WITHOUT TIME ZONE` value is cast to a `TIMESTAMP WITH TIME ZONE` value, which results in a timestamp with time zone value of

'2007-11-05-08.00.00-05:00' for column C2. The comparison predicate is false because the two values are not equal.

```
SELECT 1 FROM TABLE1 WHERE C1 = C2;
```

Example 2: When a `TIMESTAMP WITHOUT TIME ZONE` value is compared with a string representation of a `TIMESTAMP WITHOUT TIME ZONE` or a `TIMESTAMP WITH TIME ZONE` value, the string representation is cast to `TIMESTAMP WITHOUT TIME ZONE` (regardless of whether the string contains a time zone). The comparison is performed using the two `TIMESTAMP WITHOUT TIME ZONE` values. Assume that `string_hv` contains a timestamp with time zone value of '2007-11-05-08.00.00-08:00'. The string value is cast to a `TIMESTAMP WITHOUT TIME ZONE` value of '2007-11-05-08.00.00', which is compared with the value that is stored in column C2. The following `SELECT` statement returns a single row because a row exists in the table with a timestamp without time zone value of '2007-11-05-08.00.00'.

```
SELECT 1 FROM TABLE1 WHERE C2 = :string_hv;
```

Row ID comparisons

A value with a row ID type can only be compared to another row ID value.

The comparison of the row ID values is based on their internal representations. The maximum number of bytes that are compared is 17 bytes, which is the number of bytes in the internal representation. Therefore, row ID values that differ in bytes beyond the 17th byte are considered to be equal.

XML comparisons

The XML data type cannot be directly compared to any data type, including the XML data type. The method for doing comparison is through the use of the `XMLEXISTS` predicate.

Conversion rules for comparisons

When two strings are compared, one of the strings is first converted, if necessary, to the coded character set of the other string. Conversion is necessary only if certain rules apply.

Conversion is necessary only if all of the following are true:

- The CCSIDs of the two strings are different.
- Neither CCSID is X'FFFF' (neither string is defined as a binary string).
- The string selected for conversion is neither null nor empty.
- The following conversion tables ([Table 34 on page 161](#) or [Table 35 on page 162](#)) indicate when conversion is necessary.

The string selected for conversion depends on the type of the operands. For the purpose of CCSID determination, string expressions in a statement are divided into 6 types, as described in the following table.

Table 33. Operand types

Type of operand	CCSID of the operand type
Columns	CCSID from the containing table
String constants	CCSID associated with the application encoding scheme. For dynamic statements, this is the <code>CURRENT APPLICATION ENCODING SCHEME</code> special register. For static statements, this is the <code>ENCODING</code> bind option or the <code>APPLICATION ENCODING SCHEME</code> option of the <code>CREATE PROCEDURE</code> or <code>ALTER PROCEDURE</code> statement for native SQL procedures..

Table 33. Operand types (continued)

Type of operand	CCSID of the operand type
Special registers	CCSID associated with the application encoding scheme. For dynamic statements, this is the CURRENT APPLICATION ENCODING SCHEME special register. For static statements, this is the ENCODING bind option or the APPLICATION ENCODING SCHEME option of the CREATE PROCEDURE or ALTER PROCEDURE statement for native SQL procedures.
Host variables	CCSID specified in the DECLARE VARIABLE statement, associated with the application encoding scheme, or specified in SQLDAID or SQLDA
Global variables	CCSID of UNICODE
Derived value based on a column	<p>CCSID derived from the source of the derived value. A derived value based on a column is an expression whose source is directly or indirectly based on columns. The CCSID of such an expression is the CCSID derived from its source.</p> <p>For example:</p> <ul style="list-style-type: none"> • The CCSID of SUBSTR(column_1, 5, length(column_2)) is the CCSID of column_1. Note that the CCSID of column_2 has no influence on the CCSID of SUBSTR. • The CCSID of column_1 'ABC' is the CCSID of column_1, derived from the rules described in Table 34 on page 161. • The CCSID of column_1 GX'42C1' is the DBCS CCSID from the CCSID set of column_1, derived from the rules described in Table 34 on page 161 and Table 35 on page 162. • The CCSID of COALESCE(EBCDIC_column_1, ASCII_column_1) is the UNICODE CCSID, derived from the rules described in Table 34 on page 161. • The CCSID of CAST(string_column_1 AS GRAPHIC(10)) is the DBCS CCSID from the CCSID set of string_column_1. • The CCSID of CAST(EBCDIC_string_column_1 AS VARCHAR(10) CCSID UNICODE) is the UNICODE CCSID derived from the rules described in Table 34 on page 161. • The CCSID of CASE WHEN(1=1) THEN '1' ELSE ASCII_column_1 END is the CCSID of ASCII_column_1, derived from the rules described in Table 34 on page 161. • The CCSID of CASE WHEN(1=1) THEN EBCDIC_column_1 ELSE ASCII_column_1 END is the UNICODE CCSID derived from the rules described in Table 34 on page 161. • The CCSID of a scalar fullselect (SELECT column_1 FROM table_1) is the CCSID of column_1.

Table 33. Operand types (continued)

Type of operand	CCSID of the operand type
Derived value not based on a column	<p>CCSID derived from the source of the derived value. A derived value not based on a column is an expression whose source is not directly or indirectly based on any column. The CCSID of such an expression is the CCSID derived from its source.</p> <ul style="list-style-type: none"> For example, the CCSID of <code>SUBSTR('ABDC', 1, length('AB'))</code> is the CCSID of the string constant 'ABCD'. Note that the CCSID of <code>column_1</code> has no influence on the CCSID of <code>SUBSTR</code>. the CCSID of <code>user_defined_function1(column1)</code> is the output CCSID defined by <code>user_defined_function1</code>. the CCSID of the cast function of distinct type, shape, is the CCSID of distinct type, shape. the CCSID of <code>CURRENT SQLID UX'0041'</code> is the UNICODE DBCS CCSID, derived from the rules described in Table 34 on page 161 and Table 35 on page 162. the CCSID of <code>CAST('abc' as CHAR(10) CCSID UNICODE)</code> is the UNICODE CCSID.

The following table shows which operand supplies the target CCSID set when the comparison is part of an SQL statement involving multiple tables with different CCSID sets.

Table 34. Operand that supplies the CCSID for character conversion

First operand	Second operand					
	Column value	String constant	Special register	Host variable	Derived value based on a column	Derived value not based on a column
Column value	"1" on page 162	first operand	first operand	first operand, "2" on page 162	"1" on page 162	first operand
String constant	second operand	"1" on page 162	"1" on page 162	"1" on page 162	second operand	"1" on page 162
Special register	second operand	"1" on page 162	"1" on page 162	"1" on page 162	second operand	"1" on page 162
Host variable	second operand	"1" on page 162	"1" on page 162	"1" on page 162	second operand, "2" on page 162	"1" on page 162
global variable	second operand					
Derived value based on a column	"1" on page 162	first operand	first operand	first operand, "2" on page 162	"1" on page 162	first operand
Derived value not based on a column	second operand	"1" on page 162	"1" on page 162	"1" on page 162	second operand	"1" on page 162

Table 34. Operand that supplies the CCSID for character conversion (continued)

First operand	Second operand				
	Column value	String constant	Special register	Host variable	Derived value based on a column

Note:

1. If the CCSID sets are different, both operands are converted, if necessary, to Unicode. SBCS and Mixed are converted to UTF-8. DBCS is converted to UTF-16. See the next table to determine which operand supplies the CCSID for character conversion.
2. If the encoding scheme that is in effect for the statement is EBCDIC or ASCII, the host variable is Unicode graphic, and the value of the field MIXED DATA on installation panel DSNTIPF is NO, the column or the derived value that is based on a column supplies the target CCSID set.

The following table shows which operand is selected for conversion when both operands are based on a column or are not based on a column as represented in the previous table.

Table 35. Operand that supplies the CCSID for character conversion when both operands are based or not based on a column

First operand	Second operand		
	SBCS data	Mixed data	DBCS data
SBCS data		second operand ¹ on page 162	second operand
Mixed data	first operand ¹ on page 162		second operand
DBCS data	first operand	first operand	

Note:

1. For ASCII and EBCDIC data, the conversion depends on the value of the field MIXED DATA on installation panel DSNTIPF at the Db2 that does the comparison. If MIXED DATA = YES, the SBCS operand is converted to MIXED. If MIXED DATA = NO, the MIXED operand is converted to SBCS

For example, assume a comparison of the form:

```
string-constant-SBCS =derived-value-not-based-on-column-DBCS
```

Assume that the operands have different encoding schemes. First look at [Table 34 on page 161](#). The relevant table entry is in the third row and second column. The value for this entry shows that if the CCSID sets are different, the operands are converted to Unicode. The first operand (string-constant-SBCS) is converted to UTF-8 (Mixed) if it is not already Unicode. In addition, the second operand (derived-value-not-based-on-column-DBCS) is converted to UTF-16 (Unicode DBCS) if necessary. After the operands have been converted to Unicode, [Table 35 on page 162](#) is used to determine which operand supplies the specific CCSID for the conversion. The relevant table entry is in the second row and third column. It indicates that the second operand (derived-value-not-based-on-column-DBCS) determines the CCSID because DBCS data takes precedence over Mixed data.

An error occurs if a character of the string cannot be converted, the SYSSTRINGS table is used but contains no information about the pair of CCSIDs of the operands being compared, or Db2 cannot do the conversion through z/OS support for Unicode. A warning occurs if a character of the string is converted to a substitution character.

A derived value based on a column is an expression that includes columns that affects the result CCSID of the expression. For example, in the expression `COL1 || ' abc '`, `COL1` determines the result CCSID. Therefore, the expression `COL1 || ' abc '` is considered to be a derived value based on a column that continues to give the column precedence in any further comparisons. The expression `CASE WHEN COL1 > 1 THEN 'abc' ELSE 'def' END` contains a column that does not affect the result CCSID of the expression and is therefore not considered to be a derived value based on a column.

The following table defines which expressions are considered to be a derived value based on a column.

Table 36. Derived values based on a column

Expression	Condition
<code>expression1 expression2</code>	<code>expression1</code> or <code>expression2</code> is a column or a derived value based on a column
<code>CASE when-clause THEN result-expression ELSE result-expression END</code>	any <code>result-expression</code> is a <code>string-expression</code> that is a column or derived value based on a column
<code>CAST(expression as data-type)</code>	<code>expression</code> is a <code>string-expression</code> that is a column or a derived value based on a column and <code>data-type</code> is a string data type
Scalar-fullselect: (<code>SELECT expression FROM table</code>)	<code>expression</code> is a <code>string-expression</code> that is a column or a derived value based on a column and <code>data-type</code> is a string data type

When a statement contains multiple CCSID sets, if the length of one of the strings changes after CCSID conversion, the string becomes a varying-length string. That is, the data type becomes VARCHAR, CLOB, VARGRAPHIC, or DBCLOB. The following table shows the worse case resulting lengths of CCSID conversion, where X is length in bytes.

Table 37. Worst case result length of CCSID conversion, where X represents LENGTH(string in bytes)

From CCSID		To CCSID								
		EBCDIC			ASCII			Unicode		
		SBCS	Mixed	DBCS	SBCS	Mixed	DBCS	SBCS	UTF-8	UTF-16
EBCDIC	SBCS	X	X	$X * 2 \frac{1}{164}$	X	X	$X * 2 \frac{1}{164}$	$X \frac{1}{164}$ on page 164	$X * 3$	$X * 2$
	Mixed	X	X	$X * 2 \frac{1}{164}$	X	X	$X * 2 \frac{1}{164}$	$X \frac{1}{164}$ on page 164	$X * 3$	$X * 2$
	DBCS	$X * 0.5^1$	$X + 2$	X	$X * 0.5^1$	X	X	$X * 0.5$	$X * 1.5$	X
ASCII	SBCS	X	X	$X * 2 \frac{1}{164}$	X	X	$X * 2 \frac{1}{164}$	$X \frac{1}{164}$ on page 164	$X * 3$	$X * 2$
	Mixed	X	$X * 1.8$	$X * 2 \frac{1}{164}$	X	X	$X * 2^1$	$X \frac{1}{164}$ on page 164	$X * 3$	$X * 2$
	DBCS	$X * 0.5 \frac{1}{164}$	$X + 2$	X	$X * 0.5 \frac{1}{164}$	X	X	$X * 0.5$	$X * 1.5$	X

Table 37. Worst case result length of CCSID conversion, where X represents LENGTH(string in bytes) (continued)

From CCSID		To CCSID								
		EBCDIC			ASCII			Unicode		
		SBCS	Mixed	DBCS	SBCS	Mixed	DBCS	SBCS	UTF-8	UTF-16
Unicode	SBCS	X	X	X*2	X	X	X*2	X	X	X*2
	UTF-8	X	X*1.25	X	X	X	X	X	X	X*2
	UTF-16	X*0.5	X+2	X	X*0.5	X	X	X*0.5	X*1.5	X

Note:

1. Because of the high probability of data loss, IBM does not provide conversion tables for this combination of two CCSIDs and data subtypes.

User-defined type comparisons

User-defined type comparisons include distinct type comparisons and array comparisons.

Distinct type comparisons

A value with a distinct type can only be compared to another value with exactly the same type because distinct types have strong typing, which means that a distinct type is compatible only with its own type.

To compare a distinct type to a value with a different data type, the distinct type value must be cast to the data type of the comparison value or the comparison value must be cast to the distinct type. For example, because constants are built-in data types, a constant can be compared to a distinct type value only if it is first cast to the distinct type or vice versa.

The following table shows examples of valid and invalid comparisons, assuming the following SQL statements were used to define two distinct types AGE_TYPE and CAMP_DATE and table CAMP_ROSTER table.

```
CREATE TYPE AGE_TYPE AS INTEGER;
CREATE TYPE CAMP_DATE AS DATE;
CREATE TABLE CAMP_ROSTER
( NAME          VARCHAR(20),
  ATTENDEE_NUMBER INTEGER NOT NULL,
  AGE           AGE_TYPE,
  FIRST_CAMP_DATE CAMP_DATE,
  LAST_CAMP_DATE CAMP_DATE,
  BIRTHDATE    DATE);
```

Table 38. Examples of valid and invalid comparisons involving distinct types

SQL statement	Valid	Reason
Distinct types with distinct types		
<pre>SELECT * FROM CAMP_ROSTER WHERE FIRST_CAMP_DATE < LAST_CAMP_DATE;</pre>	Yes	Both values are the same distinct type.
Distinct types with columns of the same source data type		
<pre>SELECT * FROM CAMP_ROSTER WHERE AGE > ATTENDEE_NUMBER;</pre>	No	A distinct type cannot be compared to integer.

Table 38. Examples of valid and invalid comparisons involving distinct types (continued)

SQL statement	Valid	Reason
<pre>SELECT * FROM CAMP_ROSTER WHERE INTEGER(AGE) > ATTENDEE_NUMBER;</pre>	Yes	The distinct type is cast to an integer, making the comparison of two integers.
<pre>SELECT * FROM CAMP_ROSTER WHERE CAST(AGE AS INTEGER) > ATTENDEE_NUMBER;</pre>		
<pre>SELECT * FROM CAMP_ROSTER WHERE AGE > AGE_TYPE(ATTENDEE_NUMBER);</pre>	Yes	Integer ATTENDEE_NUMBER is cast to the distinct type AGE_TYPE, making both values the same distinct type.
<pre>SELECT * FROM CAMP_ROSTER WHERE AGE > CAST(ATTENDEE_NUMBER as AGE_TYPE);</pre>		
Distinct types with constants		
<pre>SELECT * FROM CAMP_ROSTER WHERE AGE IN (15,16,17);</pre>	No	A distinct type cannot be compared to a constant.
<pre>SELECT * FROM CAMP_ROSTER WHERE INTEGER(AGE) IN (15,16,17);</pre>	Yes	The distinct type is cast to the data type of constants, making all the values in the comparison integers.
<pre>SELECT * FROM CAMP_ROSTER WHERE AGE IN (AGE_TYPE(15),AGE_TYPE(16),AGE_TYPE(17));</pre>	Yes	Constants are cast to distinct type AGE_TYPE, making all the values in the comparison the same distinct type.
<pre>SELECT * FROM CAMP_ROSTER WHERE FIRST_CAMP_DATE > '06/12/99';</pre>	No	A distinct type cannot be compared to a constant.
<pre>SELECT * FROM CAMP_ROSTER WHERE FIRST_CAMP_DATE > CAST('06/12/99' AS CAMP_DATE);</pre>	No	The string constant '06/12/99', a VARCHAR data type, cannot be cast directly to distinct type CAMP_DATE, which is based on a DATE data type. As illustrated in the next row, the constant must be cast to a DATE data type and then to the distinct type.
<pre>SELECT * FROM CAMP_ROSTER WHERE FIRST_CAMP_DATE > CAST(DATE('06/12/1999') AS CAMP_DATE);</pre>	Yes	The string constant '06/12/99' is cast to the distinct type CAMP_DATE, making both values the same distinct type. To cast a string constant to a distinct type that is based on a DATE, TIME, or TIMESTAMP data type, the string constant must first be cast to a DATE, TIME, or TIMESTAMP data type.
Distinct types with host variables		
<pre>SELECT * FROM CAMP_ROSTER WHERE AGE BETWEEN :HV_INTEGER AND :HV_INTEGER2;</pre>	No	The host variables have integer data types. A distinct type cannot be compared to an integer.
<pre>SELECT * FROM CAMP_ROSTER WHERE AGE BETWEEN CAST(:HV_INTEGER AS AGE_TYPE) AND AGE_TYPE(:HV_INTEGER2);</pre>	Yes	The host variables are cast to distinct type AGE_TYPE, making all the values the same distinct type.

Table 38. Examples of valid and invalid comparisons involving distinct types (continued)

SQL statement	Valid	Reason
<pre>SELECT * FROM CAMP_ROSTER WHERE FIRST_CAMP_DATE > :HV_VARCHAR;</pre>	No	The host variable has a VARCHAR data type. A distinct type cannot be compared to a VARCHAR.
<pre>SELECT * FROM CAMP_ROSTER WHERE FIRST_CAMP_DATE > CAST (DATE (:HV_VARCHAR) AS CAMP_DATE);</pre>	Yes	The host variable is cast to the distinct type CAMP_DATE, making both values the same distinct type. To cast a VARCHAR host variable to a distinct type that is based on a DATE, TIME, or TIMESTAMP data type, the host variable must first be cast to a DATE, TIME, or TIMESTAMP data type.

Array type comparisons

Comparisons of array values are not supported. Elements of arrays can be compared based on the comparison rules for the data types of the elements of the arrays.

Rules for result data types

Rules that are applied to the operands of an operation determine the data type of the result. Certain rules apply in certain situations and apply depending on the data type of operands.

The rules apply to the following elements:

- Corresponding columns in set operations (UNION, INTERSECT, or EXCEPT)
- Result expressions of a CASE expression
- Arguments of the scalar functions COALESCE, IFNULL, MAX, and MIN
- Expression values of the IN list of an IN predicate
- Expression values for the elements in an array constructor
- Expression values for the arguments for a collection-derived table (UNNEST specification)
- Arguments of a BETWEEN predicate, except if the data types of all operands are numeric
- Arguments for the aggregation group ranges in OLAP specifications

For the result data type of expressions that involve the operators '/', '*', '+' and '-', see [“Arithmetic operators in expressions”](#) on page 250.

For the result data type of expressions that involve the CONCAT operator, see [“Concatenation operators in expressions”](#) on page 247.

Evaluation of the operands of an operation determines the data type of the result. If an operation has more than one pair of operands, Db2 determines the result type of the first pair, uses this result type with the next operand to determine the next result type, and so on. The last intermediate result type and the last operand determine the result type of the operation.

With the exception of the COALESCE function, the result of an operation can be null unless the operands do not allow nulls.

If the data type and attributes of any operand column are not the same as those of the result, the operand column values are converted to conform to the data type and attributes of the result. The conversion operation is exactly the same as if the values were assigned to the result. For example:

- If one operand column is CHAR(10), and the other operand column is CHAR(5), the result is CHAR(10), and the values derived from the CHAR(5) column are padded on the right with five blanks.
- If the whole part of a number cannot be preserved then an error is returned.

Numeric operands

Numeric types are compatible only with other numeric types.

Table 39. Result data types with numeric operands

One operand	Other operand	Data type of the result
SMALLINT	SMALLINT	SMALLINT
INTEGER	INTEGER	INTEGER
INTEGER	SMALLINT	INTEGER
BIGINT	SMALLINT	BIGINT
BIGINT	INTEGER	BIGINT
BIGINT	BIGINT	BIGINT
DECIMAL(<i>w</i> , <i>x</i>)	SMALLINT	DECIMAL(<i>p</i> , <i>x</i>) where $p = x + \max(w - x, 5)$ ¹
DECIMAL(<i>w</i> , <i>x</i>)	INTEGER	DECIMAL(<i>p</i> , <i>x</i>) where $p = x + \max(w - x, 11)$ ¹
DECIMAL(<i>w</i> , <i>x</i>)	BIGINT	DECIMAL(<i>p</i> , <i>x</i>) where $p = x + \max(w - x, 19)$ ¹
DECIMAL(<i>w</i> , <i>x</i>)	DECIMAL(<i>y</i> , <i>z</i>)	DECIMAL(<i>p</i> , <i>s</i>) where $p = \max(x, z) + \max(w - x, y - z)$ ¹ $s = \max(x, z)$
REAL	REAL	REAL
REAL	DECIMAL, BIGINT, INTEGER, or SMALLINT	DOUBLE
REAL	BIGINT	DOUBLE
DOUBLE	DOUBLE, REAL, DECIMAL, BIGINT, INTEGER, or SMALLINT	DOUBLE
DECFLOAT(<i>n</i>)	SMALLINT	DECFLOAT(<i>n</i>)
DECFLOAT(<i>n</i>)	INTEGER	DECFLOAT(<i>n</i>)
DECFLOAT(<i>n</i>)	BIGINT	DECFLOAT(34)
DECFLOAT(<i>n</i>)	DECIMAL(<=16, <i>s</i>)	DECFLOAT(<i>n</i>)
DECFLOAT(<i>n</i>)	DECIMAL(>16, <i>s</i>)	DECFLOAT(34)
DECFLOAT(<i>n</i>)	REAL	DECFLOAT(<i>n</i>)
DECFLOAT(<i>n</i>)	DOUBLE	DECFLOAT(<i>n</i>)
DECFLOAT(<i>n</i>)	DECFLOAT(<i>m</i>)	DECFLOAT(max(<i>n</i> , <i>m</i>))

Notes:

1. Precision cannot exceed 31.

Character and graphic string operands

Character and graphic strings are compatible with other character and graphic strings as long as there is a conversion between their corresponding CCSIDs.

Table 40. Result data types with string operands

One operand	Other operand	Data type of the result
CHAR(<i>x</i>)	CHAR(<i>y</i>)	CHAR(<i>z</i>) where $z = \max(x, y)$
GRAPHIC(<i>x</i>)	CHAR(<i>y</i>)	VARGRAPHIC(<i>y</i>) where $y >$ maximum length of a graphic
GRAPHIC(<i>x</i>)	CHAR(<i>y</i>)	GRAPHIC(<i>z</i>) where $z = \max(x, y)$
VARCHAR(<i>x</i>)	VARCHAR(<i>y</i>) or CHAR(<i>y</i>)	VARCHAR(<i>z</i>) where $z = \max(x, y)$
VARCHAR(<i>x</i>)	GRAPHIC(<i>y</i>)	VARGRAPHIC(<i>z</i>) where $z = \max(x, y)$
VARGRAPHIC(<i>x</i>)	VARGRAPHIC(<i>y</i>), GRAPHIC(<i>y</i>), VARCHAR(<i>y</i>), or CHAR(<i>y</i>)	VARGRAPHIC(<i>z</i>) where $z = \max(x, y)$
CLOB(<i>x</i>)	CLOB(<i>y</i>), VARCHAR(<i>y</i>), or CHAR(<i>y</i>)	CLOB(<i>z</i>) where $z = \max(x, y)$
CLOB(<i>x</i>)	GRAPHIC(<i>y</i>) or VARGRAPHIC(<i>y</i>)	DBCLOB(<i>z</i>) where $z = \max(x, y)$
DBCLOB(<i>x</i>)	CHAR(<i>y</i>), VARCHAR(<i>y</i>), CLOB(<i>y</i>), GRAPHIC(<i>y</i>), VARGRAPHIC(<i>y</i>), or DBCLOB(<i>y</i>)	DBCLOB(<i>z</i>) where $z = \max(x, y)$

Character string subtypes are determined as indicated in the following table:

Table 41. Result data types with character string operands

One operand	Other operand	Data type of the result
Bit data	Mixed, SBCS, or bit data	Bit data
Mixed data	Mixed or SBCS data	Mixed data
SBCS data	SBCS data	SBCS data

Binary string operands

Binary strings are compatible with other binary strings. Binary strings include BINARY, VARBINARY, and BLOB.

Table 42. Result data types with binary string operands

One operand	Other operand	Data type of the result
BINARY(<i>x</i>)	BINARY(<i>y</i>)	BINARY(<i>z</i>) where $z = \max(x, y)$
VARBINARY(<i>x</i>)	BINARY(<i>y</i>) or VARBINARY(<i>y</i>)	VARBINARY(<i>z</i>) where $z = \max(x, y)$
BLOB(<i>x</i>)	BINARY(<i>y</i>), VARBINARY(<i>y</i>), or BLOB(<i>y</i>)	BLOB(<i>z</i>) where $z = \max(x, y)$

Datetime operands

A date, time, or timestamp value is compatible with another value of the same type or any string expression that contains a valid string representation of the same type.

A DATE type is compatible with another DATE type or any string expression that contains a valid string representation of a date. A string representation is a value that is a built-in character string data type or graphic string data type. A string representation must not be a CLOB or DBCLOB and must have an actual length that is not greater than 255 bytes. The data type of the result is DATE.

A TIME type is compatible with another TIME type or any string expression that contains a valid string representation of a time. A string representation is a value that is a built-in character string data type or graphic string data type. A string representation must not be a CLOB or DBCLOB and must have an actual length that is not greater than 255 bytes. The data type of the result is TIME.

A timestamp type is compatible with another timestamp type, a timestamp constant, or any string expression that contains a valid string representation of a timestamp. A string representation is a value that is a built-in character string data type or graphic string data type. A string representation must not be a CLOB or DBCLOB and must have an actual length that is not greater than 255 bytes. The data type of the result is a timestamp as determined in the following table.

Table 43. Result data types with datetime operands

One operand	Other operand	Data type of the result
TIMESTAMP(x) WITHOUT TIME ZONE	TIMESTAMP(y) WITHOUT TIME ZONE	TIMESTAMP(max(x,y)) WITHOUT TIME ZONE
TIMESTAMP(x) WITHOUT TIME ZONE	CHAR(y) or VARCHAR(y)	TIMESTAMP(x) WITHOUT TIME ZONE ¹
TIMESTAMP(x) WITH TIME ZONE	TIMESTAMP(y) WITH TIME ZONE	TIMESTAMP(max(x,y)) WITH TIME ZONE
TIMESTAMP(x) WITH TIME ZONE	CHAR(y) or VARCHAR(y)	TIMESTAMP(x) WITH TIME ZONE
TIMESTAMP(x) WITH TIME ZONE	TIMESTAMP(y) WITHOUT TIME ZONE	TIMESTAMP(max(x,y)) WITH TIME ZONE

Note: If one operand is TIMESTAMP(x) WITHOUT TIME ZONE and the other operand is CHAR(y) or VARCHAR(y), the result data type is TIMESTAMP(x) WITHOUT TIME ZONE even if the string representation contains a time zone.

If both operands are in the same encoding scheme, the result is in that encoding scheme. Otherwise the result is in the application encoding scheme.

Row ID operands

A row ID data type is compatible only with itself. The result has a row ID data type.

XML operands

XML data is compatible only with other XML data. The data type of the result is XML. Other data types can be treated as an XML data type by using the CAST specification or XMLPARSE functions to cast character, graphic, or binary data to XML data.

Distinct type operands

A distinct type is compatible only with itself. The data type of the result is the distinct type.

Related concepts

[Conversion rules for comparisons](#)

When two strings are compared, one of the strings is first converted, if necessary, to the coded character set of the other string. Conversion is necessary only if certain rules apply.

Constants

A *constant* (also called a *literal*) specifies a value. Constants are classified as null constants, string constants, numeric constants, or datetime constants. Numeric constants are further classified as integer, floating-point, decimal, or decimal floating-point. String constants are classified as character, graphic, or binary.

All constants, except null constants, have the attribute NOT NULL. A negative sign in a numeric constant with a value of zero is ignored.

Constants, other than null constants, have a built-in data type. Therefore, an operation that involves a constant and a distinct type requires that the distinct type be cast to the built-in data type of the constant or the constant be cast to the distinct type. For example, see [“User-defined type comparisons”](#) on page 164, which contains an example of casting data types to compare a constant to a distinct type.

Null constants

A null constant indicates the null value.

The NULL constant has no data type. The data type of the NULL keyword is provided by the context in which it is used, or you can use CAST to assign a data type.

Integer constants

An *integer constant* specifies an integer as a signed or unsigned number with a maximum of 19 digits that does not include a decimal point.

The data type of an integer constant is large integer if its value is within the range of a large integer. The data type of an integer constant is big integer if its value is outside the range of a large integer, but within the range of a big integer. A constant that is defined outside the range of big integer values is considered a decimal constant.

For example, the following values are integer constants:

```
64      -15      +100     32767     720176
```

In syntax diagrams, the term *integer* is used for a large integer constant that must not include a sign.

Floating-point constants

A *floating-point constant* specifies a double-precision floating-point number as two numbers separated by an E.

The first number can include a sign and a decimal point. The second number can include a sign but not a decimal point. The value of the constant is the product of the first number and the power of 10 specified by the second number. It must be within the range of floating-point numbers. The number of characters in the constant must not exceed 30. Excluding leading zeros, the number of digits in the first number must not exceed 17 and the number of digits in the second must not exceed 2.

For examples, the following floating-point constants represent the numbers '150', '200000', -0.22, and '500':

```
15E1      2.E5      -2.2E-1     +5.E+2
```

Decimal constants

A decimal constant is a signed or unsigned number of no more than 31 digits and either includes a decimal point or is not within the range of binary integers.

The precision is the total number of digits, including those, if any, to the right of the decimal point. The total includes all leading and trailing zeros. The scale is the number of digits to the right of the decimal point, including trailing zeros.

The precision is the total number of digits, including those, if any, to the right of the decimal point. The total includes all leading and trailing zeros. The scale is the number of digits to the right of the decimal point, including trailing zeros.

For example, the following decimal constants have, respectively, precisions and scales of 5 and 2; 4 and 0; 2 and 0; and 23 and 2:

```
025.50  1000.  -15.  +37589333333333333333.33
```

Decimal floating-point constant

A *decimal floating-point* constant specifies a decimal floating-point number as two numbers separated by an E. The first number can include a sign and a decimal point. The second number can include a sign but not a decimal point.

The value of the constant is the product of the first number and the power of 10 specified by the second number. The value must be within the range of DECFLOAT(34). The number of characters in the constant must not exceed 42. Excluding leading zeros, the number of digits in the first number must not exceed 34 and the number of digits in the second number must not exceed 4.

A constant that is specified as two numbers separated by an E is a decimal-floating point constant only if the value is outside the range of a floating-point constant. A constant that is specified as a number that does not contain an E, and has more than 31 digits, is also a decimal-floating point constant.

In addition to numeric constants, the following special values can be used to specify decimal-floating point special values:

- INF or INFINITY - represents infinity
- NAN - represents quiet not-a-number
- SNAN - represents signaling not-a-number

The special values can be any combination of uppercase or lowercase letters and can be preceded by an operational sign (+ or -).

SNAN results in a warning or exception when it is used in a numerical operation; NAN does not. SNAN can be used in non-numerical operations without causing a warning or exception. For example, SNAN can be used in the VALUES list of an insert operation or as a constant used in a comparison in a predicate.

When the special values are used in a predicate, the following order of precedence applies:

```
-NAN < -SNAN < -INFINITY < -0 < 0 < INFINITY < SNAN < NAN
```

For example, The following decimal floating-point constants represent the numbers 123456789012345678, sNaN, and negative infinity:

```
123456789012345678E0  SNAN  -INFINITY
```

When one of the special values is used in a context where it could be interpreted as an identifier, such as a column name, cast a string constant that represents the special value to decimal-floating point.

```
CAST ('snan' AS DECFLOAT)  
CAST ('INF' AS DECFLOAT)  
CAST ('Nan' AS DECFLOAT)
```

Character string constants

A *character string constant* specifies a varying-length character string. A character string constant has one of the two following forms:

- A sequence of characters that starts and ends with a string delimiter, which is either an apostrophe (') or a quotation mark ("). For the factors that determine which is applicable, see [“Apostrophes and quotation marks as string delimiters”](#) on page 324. This form of string constant specifies the character string contained between the string delimiters. The number of bytes between the delimiters must not be greater than 32704. The limit of 32704 refers to the length (in bytes) of the UTF-8 representation of the string. If you produced the string in a CCSID other than UTF-8 (for example, an EBCDIC CCSID), the length of the UTF-8 representation might differ from the length of the string's representation in the source CCSID. Two consecutive string delimiters are used to represent one string delimiter within the character string.
- An X followed by a sequence of characters that starts and ends with a string delimiter. This form of a character string constant is also called a *hexadecimal constant*. The characters between the string delimiters must be an even number of hexadecimal digits. The number of hexadecimal digits must not exceed 32704. A hexadecimal digit is a digit or any of the letters A through F. If the MIXED DATA subsystem parameter is set to YES, hexadecimal digits in a hexadecimal constant must be specified in upper case. Otherwise, an error might be returned when SQL statements are processed. Under the conventions of hexadecimal notation, each pair of hexadecimal digits represents a character. A hexadecimal constant allows you to specify characters that do not have a keyboard representation.

The following examples are character strings constants. The right most string in the example (') represents an empty character string constant, which is a string of zero length.

```
'12/14/1985'   '32'   'DON'T CHANGE'   X'FFFF'   ''
```

A character string constant is classified as mixed data if it includes a DBCS substring. In all other cases, a character string constant is classified as SBCS data. For information about the CCSID that is assigned to the constant, see [Determining the encoding scheme and CCSID of a string \(Introduction to Db2 for z/OS\)](#). A mixed string constant can be continued from one line to the next only if the break occurs between single byte characters. A Unicode string is always considered mixed regardless of the content of the string.

For Unicode, character constants can be assigned to UTF-8 and UTF-16. The form of the constant does not matter. Typically, character string constants are used only with character strings, but they also can be used with graphic UTF-16 data. However, hexadecimal constants are just character data. Thus, hexadecimal constants being used to insert data into UTF-16 data strings should be in UTF-8 format, not UTF-16 format. For example, if you wanted to insert the number 1 into a UTF-16 column, you would use X'31', not X'0031'. Even though X'0031' is a UTF-16 value, Db2 treats it as two separate UTF-8 code points. Thus, X'0031' would become X'0000031'.

Binary string constants

A *binary-string constant* specifies a varying-length binary string.

A binary-string constant is formed by specifying a BX followed by a sequence of characters that starts and ends with a string delimiter. The characters between the string delimiters must be an even number of hexadecimal digits. The number of hexadecimal digits must not exceed 32704.

A hexadecimal digit is a digit or any of the letters A through F (upper case or lower case). Under the conventions of hexadecimal notation, each pair of hexadecimal digits represents one byte. Note that this representation is similar to the representation of the character-constant that uses the X'' form; however binary-string constant and character-string constant are not compatible and the X'' form can not be used to specify a binary-string constant, just as the BX'' form cannot be used to specify a character-string constant.

he following examples are binary-string constants:

```
BX'0000'   BX'C141C242'   BX'FF00FF01FF'
```

Graphic string constants

A *graphic string constant* specifies a varying-length graphic string. For more information, see [“Graphic string constants” on page 173](#).

Datetime constants

A *datetime constant* is a character string constant of a particular format. For more information, see [“Datetime constants” on page 174](#)

Related concepts

Data types

Db2 supports both IBM-supplied data types (built-in data types) and user-defined data types (distinct types).

Graphic string constants

A *graphic string constant* specifies a varying-length graphic string.

In EBCDIC environments, the forms of graphic string constants are shown in the following figure. (Shift-in and shift-out characters for EBCDIC data are discussed in [“Character strings” on page 102](#).)⁶

Context	Graphic String Constant	Empty String	Example
PL/I	%'dbcs-string' G _s %'dbcs-string' _s G G represents a DBCS G (X'42C7') ' represents a DBCS apostrophe (X'427D')	%'' _s %'' _s G	%'元氣' _s
All other contexts	G%'dbcs-string' _s N%'dbcs-string' _s	G'' _s G'' g'' _s g'' N'' _s N'' n'' _s n''	G%'元氣' _s

Lorem ipsum

Figure 23. Graphic string constants in EBCDIC

In SQL statements and in host language statements in a source program, graphic string constants cannot be continued from one line to the next. A graphic string constant must be short enough so that its UTF-8 representation requires no more than 32704 bytes.

Db2 supports two types of hexadecimal graphic string constants.

- UX'xxxx' represents a string of graphic Unicode UTF-16 characters, where x is a hexadecimal digit. The number of digits must be a multiple of 4 and must not exceed 32704. Each group of 4 digits represents a single UTF-16 graphic character. For example, the UX constant for 'ABC' is UX'004100420043'.
- GX'xxxx' represents a string of graphic characters, where x is a hexadecimal digit. The number of digits must be a multiple of 4. Each group of 4 digits represents a single double-byte graphic character. The

⁶ The PL/I form of graphic string constants is supported only in static SQL statements.

hexadecimal shift-in and shift-out ('OE'X and 'OF'X), which apply to EBCDIC only, are not included in the string.

If the MIXED DATA installation option is set to NO, a GX constant cannot be used. Instead, a UX constant should be used. A GX constant cannot be used when the encoding scheme is UNICODE.

For information about the CCSID that is assigned to a graphic string constant, including UX'xxxx' and GX'xxxx' string constants, see [Determining the encoding scheme and CCSID of a string \(Introduction to Db2 for z/OS\)](#).

Datetime constants

A *datetime constant* is a character string constant of a particular format.

For more information about character-string constants, see [“Constants” on page 170](#).

For information about the valid string formats, see [“String representations of datetime values” on page 120](#).

Typically, character-string constants are used to represent constant datetime values in assignments and comparisons. However, the ANSI/ISO SQL standard form of a datetime constant can be used to specifically denote the constant as a datetime constant instead of a character-string constant. The format for the ANSI/ISO SQL standard datetime constants are as follows:

DATE *string-constant*

string-constant must contain a value that conforms to one of the valid formats for string representations of dates, subject to the following rules:

- leading blanks are not allowed.
- leading zeros can be omitted from the month and day elements of the date. An implicit specification of 0 is assumed for any digit that is omitted.
- leading zeros must be included for the year element of the date.
- trailing blanks can be included.

The data type of the value is DATE.

TIME *string-constant*

string-constant must contain a value that conforms to one of the valid formats for string representations of times, subject to the following rules:

- leading blanks are not allowed.
- leading zeros can be omitted from the hour elements of the time.
- the seconds element of the time can be omitted.
- trailing blanks can be included.
- if the USA format is not used and the minutes and seconds are all zeros, the hour can be 24.
- If the format is USA, the following additional rules apply:
 - the minutes element of the time can be omitted. For example, 1 PM is equivalent to 1:00 PM.
 - the letters A, M, and P can be specified in lowercase.
 - a single blank must precede the AM or PM.
 - the hour must not be greater than 12 and cannot be 0 except when the time is specified as 00:00 AM.

An implicit specification of 0 is assumed for any digit that is omitted.

The correspondence between the USA format and the ISO format (24-hour clock) is as follows:

- 12:01 AM through 12:59 AM correspond to 00.01.00 through 00.59.00
- 01:00 AM through 11:59 AM correspond to 01.00.00 through 11.59.00
- 12:00 PM (noon) through 11:59 PM correspond to 12.00.00 through 23.59.00

- 12:00 AM (midnight) corresponds to 24.00.00
- 00:00 AM (midnight) corresponds to 00.00.00

The data type of the value is TIME.

TIMESTAMP string-constant

string-constant must contain a value that conforms to one of the formats listed in the following tables, subject to the following rules:

- leading blanks are not allowed.
- trailing blanks can be included.
- leading zeros can be omitted from the month, day, hour, and time zone hour elements of the timestamp. An implicit specification of 0 is assumed for any digit that is omitted.
- leading zeros must be included for the minute, second, and time zone minute elements of the timestamp
- the hour can be 24 if the minutes, seconds, and any fractional seconds are all zeroes.
- the separator character that follows the seconds element can be omitted if fractional seconds are not included.
- the number of digits of fractional seconds can vary from 0 to 12. An implicit specification of 0 is assumed if fractional seconds are omitted. The number of digits of fractional seconds determines the precision of the timestamp value.
- an optional single blank can be included between the time and the time zone elements.
- an optional time zone can be included, in one of the following formats:
 - ±th:tm, with values ranging from -24:00 to +24:00. A value of -0:00 is treated the same as +0:00.
 - ±th, with values ranging from -24 to +24 (an implicit specification of 00 is assumed for the time zone minute element)
 - uppercase Z to specify UTC

The data type of the value depends on the content of the string constant (where *p* is the number of digits of fractional seconds in the constant):

- **TIMESTAMP(*p*) WITHOUT TIME ZONE** if the content of the string constant conforms to the rules in the [Table 44 on page 175](#) table.
- **TIMESTAMP(*p*) WITH TIME ZONE** if the content of the string constant conforms to the rules in the [Table 45 on page 176](#) table.

Table 44. Formats used to specify a value for a data type of TIMESTAMP WITHOUT TIME ZONE

Description	TIMESTAMP(0) WITHOUT TIME ZONE ^{1, 3}	TIMESTAMP(<i>p</i>) WITHOUT TIME ZONE ^{2, 3}
Blank between date and time portions and colons in time portion.	<ul style="list-style-type: none"> • yyyy-mm-dd hh:mm:ss • yyyy-mm-dd hh:mm:ss. 	yyyy-mm-dd hh:mm:ss.nnnnnnnnnnnn
Blank between date and time portions and periods in time portion.	<ul style="list-style-type: none"> • yyyy-mm-dd hh.mm.ss • yyyy-mm-dd hh.mm.ss. 	yyyy-mm-dd hh.mm.ss.nnnnnnnnnnnn
Minus sign between date and time portions and colons in time portion.	<ul style="list-style-type: none"> • yyyy-mm-dd-hh:mm:ss • yyyy-mm-dd-hh:mm:ss. 	yyyy-mm-dd- hh:mm:ss.nnnnnnnnnnnn
Minus sign between date and time portions and periods in time portion.	<ul style="list-style-type: none"> • yyyy-mm-dd-hh.mm.ss • yyyy-mm-dd-hh.mm.ss. 	yyyy-mm-dd- hh.mm.ss.nnnnnnnnnnnn

Table 44. Formats used to specify a value for a data type of **TIMESTAMP WITHOUT TIME ZONE** (continued)

Description	TIMESTAMP(0) WITHOUT TIME ZONE ^{1, 3}	TIMESTAMP(p) WITHOUT TIME ZONE ^{2, 3}
Notes:		
1. No fractional seconds; shown with and without optional trailing period after seconds		
2. <i>p</i> is the number of digits of fractional seconds. <i>nnnnnnnnnnnn</i> can range 1 - 12 instances of <i>n</i>		
3. As an additional format, the character T can be substituted as the separator between the date and time portions of the value.		

Table 45. Formats used to specify a value for a data type of **TIMESTAMP WITH TIME ZONE**

Description	TIMESTAMP(0) WITH TIME ZONE ^{1, 3}	TIMESTAMP(p) WITH TIME ZONE ^{2, 3}
Blank between date and time portions and colons in time portion, no space between time and time zone.	<ul style="list-style-type: none"> • yyyy-mm-dd hh:mm:ss±th:tm • yyyy-mm-dd hh:mm:ss±th • yyyy-mm-dd hh:mm:ss.±th:tm • yyyy-mm-dd hh:mm:ss.±th 	<ul style="list-style-type: none"> • yyyy-mm-dd hh:mm:ss.nnnnnnnnnnn ±th:tm • yyyy-mm-dd hh:mm:ss.nnnnnnnnnnn ±th
Minus sign between date and time portions and colons in time portion.	<ul style="list-style-type: none"> • yyyy-mm-dd-hh:mm:ss±th:tm • yyyy-mm-dd-hh:mm:ss±th • yyyy-mm-dd-hh:mm:ss.±th:tm • yyyy-mm-dd-hh:mm:ss.±th 	<ul style="list-style-type: none"> • yyyy-mm-dd-hh:mm:ss.nnnnnnnnnnn ±th:tm • yyyy-mm-dd-hh:mm:ss.nnnnnnnnnnn ±th
Minus sign between date and time portions and periods in time portion.	<ul style="list-style-type: none"> • yyyy-mm-dd-hh.mm.ss±th:tm • yyyy-mm-dd-hh.mm.ss±th • yyyy-mm-dd-hh.mm.ss.±th:tm • yyyy-mm-dd-hh.mm.ss.±th 	<ul style="list-style-type: none"> • yyyy-mm-dd-hh.mm.ss.nnnnnnnnnnn ±th:tm • yyyy-mm-dd-hh.mm.ss.nnnnnnnnnnn ±th
Blank between date and time portions, colons in time portion, blank between fractional seconds and sign for time zone.	<ul style="list-style-type: none"> • yyyy-mm-dd hh:mm:ss ±th:tm • yyyy-mm-dd hh:mm:ss ±th • yyyy-mm-dd hh:mm:ss. ±th:tm • yyyy-mm-dd hh:mm:ss. ±th 	<ul style="list-style-type: none"> • yyyy-mm-dd hh:mm:ss.nnnnnnnnnnn ±th:tm • yyyy-mm-dd hh:mm:ss.nnnnnnnnnnn ±th
Blank between date and time portions and periods in time portion.	<ul style="list-style-type: none"> • yyyy-mm-dd hh.mm.ss±th:tm • yyyy-mm-dd hh.mm.ss±th • yyyy-mm-dd hh.mm.ss.±th:tm • yyyy-mm-dd hh.mm.ss.±th 	<ul style="list-style-type: none"> • yyyy-mm-dd hh.mm.ss.nnnnnnnnnnn ±th:tm • yyyy-mm-dd hh.mm.ss.nnnnnnnnnnn ±th

Table 45. Formats used to specify a value for a data type of *TIMESTAMP WITH TIME ZONE* (continued)

Description	TIMESTAMP(0) WITH TIME ZONE^{1, 3}	TIMESTAMP(<i>p</i>) WITH TIME ZONE^{2, 3}
-------------	---	--

Notes:

1. No fractional seconds; shown with and without optional trailing period after seconds
 2. *p* is the number of digits of fractional seconds. *nnnnnnnnnnnn* can range 1 - 12 instances of *n*
 3. As an additional format, the character T can be substituted as the separator between the date and time portions of the value.
-

Special registers

A special register is a storage area that is defined for an application process by Db2 and is used to store information that can be referenced in SQL statements. A reference to a special register is a reference to a value provided by the current server. If the value is a string, its CCSID is a default CCSID of the current server.

The special registers can be referenced as follows:

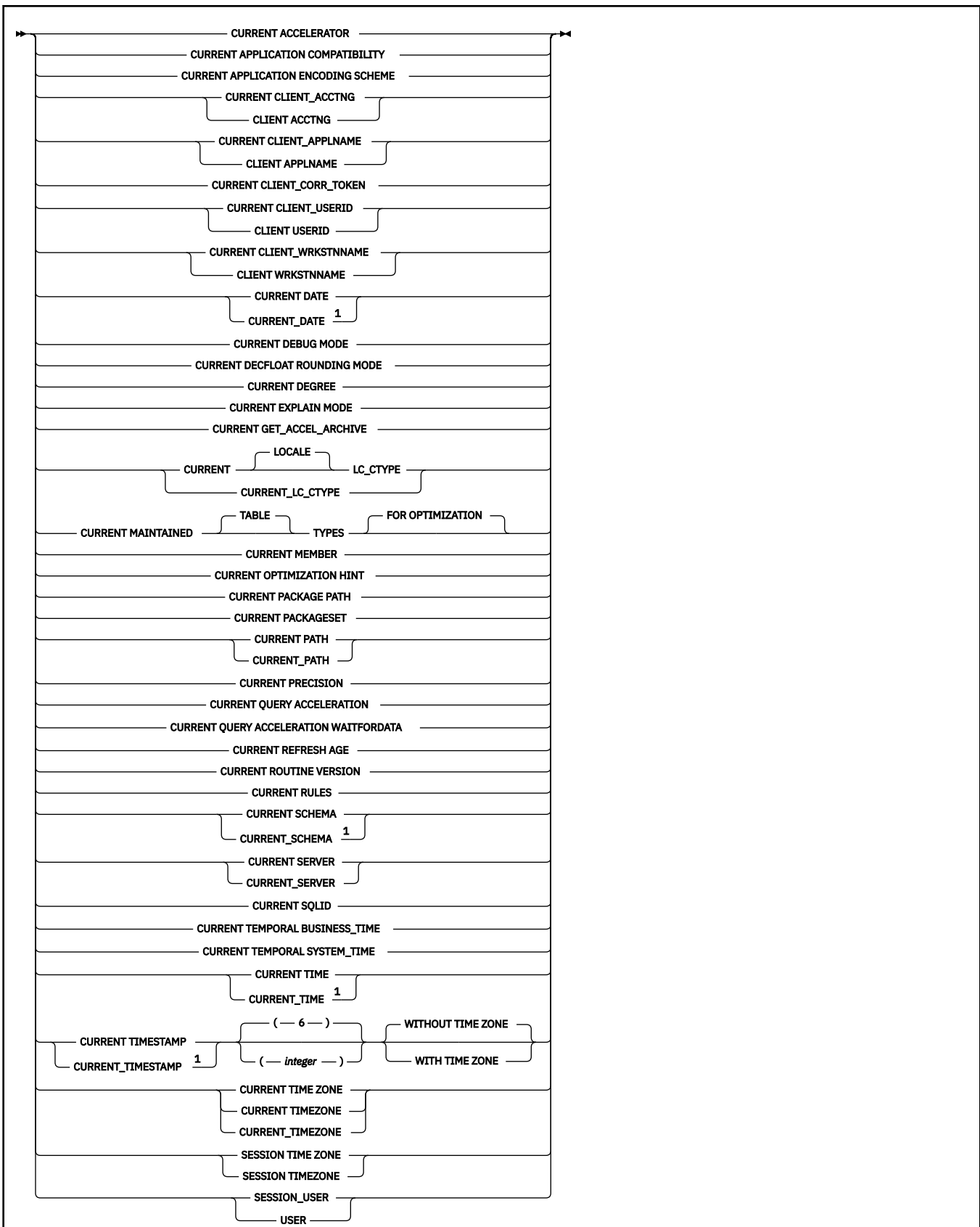

Notes:

¹ The SQL standard uses the form with the underline.

General rules for special registers

Changing register values

A commit operation might cause special registers to be re-initialized. Whether a special register is affected by a commit depends on whether the special register has been explicitly set within the application process. For example, assume that the PATH special register has not been explicitly set with a SET PATH statement in the application process. After a commit, the value of PATH is re-initialized. For information on the initialization of PATH, which can take the current value of CURRENT SQLID into consideration, see [“CURRENT SQLID special register”](#) on page 207.

A rollback operation has no effect on the values of special registers. Nor does any SQL statement, with the following exceptions:

- SQL SET statements can change the values of the following special registers:

- CURRENT ACCELERATOR
- CURRENT APPLICATION COMPATIBILITY
- CURRENT APPLICATION ENCODING SCHEME
- CURRENT DEBUG MODE
- CURRENT DECFLOAT ROUNDING MODE
- CURRENT DEGREE
- CURRENT EXPLAIN MODE
- CURRENT GET_ACCEL_ARCHIVE
- CURRENT LOCALE LC_CTYPE
- CURRENT LOCK TIMEOUT
- CURRENT MAINTAINED TABLE TYPES FOR OPTIMIZATION
- CURRENT OPTIMIZATION HINT
- CURRENT PACKAGE PATH
- CURRENT PACKAGESET
- CURRENT PATH
- CURRENT PRECISION
- CURRENT QUERY ACCELERATION
- CURRENT QUERY ACCELERATION WAITFORDATA
- CURRENT REFRESH AGE
- CURRENT ROUTINE VERSION
- CURRENT RULES
- CURRENT SCHEMA
- CURRENT SQLID⁷
- CURRENT TEMPORAL BUSINESS_TIME
- CURRENT TEMPORAL SYSTEM_TIME
- ENCRYPTION PASSWORD
- SESSION TIME ZONE

⁷ If the SET CURRENT SQLID statement is executed in a stored procedure or user-defined function package that has a dynamic SQL behavior other than run behavior, the SET CURRENT SQLID statement does not affect the authorization ID that is used for dynamic SQL statements in the package. The dynamic SQL behavior determines the authorization ID. For more information, see [DYNAMICRULES bind option \(Db2 Commands\)](#).

- SQL CONNECT statements can change the value of CURRENT SERVER.

Changing register values from IBM Data Server clients and drivers

In addition to using SQL SET statements, you can use the following IBM Data Server client and driver interfaces to change the values of most of the special registers that are listed under [“Changing register values”](#) on page 179:

- IBM Data Server Driver for JDBC and SQLJ method `DB2DataSource.setSpecialRegisters`
- For non-Java clients, the <specialregisters> subsection in the in db2dsdriver.cfg file

Use of these interfaces has the following restrictions:

- You cannot change the values of the following special registers:
 - CURRENT APPLICATION ENCODING SCHEME
 - CURRENT PACKAGESET
- The special register names are allowed to be in mixed case. Extraneous blanks between keywords are removed.
- The special register assigned value is stored as specified. The value must be valid for the special register.
- Special register values cannot be expressions, cannot reference other special registers, and cannot reference global variables.
- For CURRENT REFRESH AGE, the value 99999999999999 is not supported. Use the value ANY instead.
- Db2 treats all special register values that are passed through the client and driver interfaces as literal strings. For example, if a specified special register value is the same as the name of a special register, Db2 stores the special register name, and not the special register value.

Determining register values

You can use various statements to determine the value of a special register. For instance, a SELECT statement or a SET statement will provide the value of a special register. The following examples find the value of the CURRENT PRECISION special register:

```
SELECT CURRENT PRECISION FROM SYSIBM.SYSDUMMY1;
SET :hv = CURRENT PRECISION
```

CCSIDS for register values

Special registers that contain character strings have an associated CCSID. The particular CCSID depends on the context in which the special register is referenced. For more information, see [Determining the encoding scheme and CCSID of a string \(Introduction to Db2 for z/OS\)](#).

Datetime special registers

The datetime registers are named CURRENT DATE, CURRENT TIME, and CURRENT TIMESTAMP. Datetime special registers are stored in an internal format. When two or more of these registers are implicitly or explicitly specified in a single SQL statement, they represent the same point in time. A datetime special register is implicitly specified when it is used to provide the default value of a datetime column.

If the SQL statement in which a datetime special register is used is in a user-defined function or stored procedure that is within the scope of a trigger, Db2 uses the timestamp for the triggering SQL statement to determine the special register value.

The values of these special registers are based on:

- The time-of-day clock of the processor for the server executing the SQL statement
- The TIMEZONE parameter for this processor. The TIMEZONE parameter is in SYS1.PARMLIB(CLOCKXX).

To evaluate the references when the statement is being executed, a single reading from the time-of-day clock is incremented by the number of hours, minutes, and seconds specified by the TIMEZONE parameter. The values derived from this are assumed to be the local date, time, or timestamp, where local means local to the Db2 that executes the statement. This assumption is correct if the clock is set to local time and the TIMEZONE parameter is zero or the clock is set to UTC (Coordinated Universal Time) and the TIMEZONE parameter gives the difference from UTC.

Because the datetime special registers and the CURRENT TIMEZONE special register depend on the parameter PARMTZ(SYS1.PARMLIB(CLOCKXX)), their values are affected if the local time at the server is changed by the z/OS system command SET CLOCK. The values of the CURRENT DATE and CURRENT TIMESTAMP special registers might be affected if the local date at the server is changed by the system command SET DATE⁸.

Where special registers are processed

In distributed applications, CURRENT APPLICATION ENCODING SCHEME, CURRENT SERVER, and CURRENT PACKAGESET are processed locally. All other special registers are processed at the server.

Rules for setting special registers by using profile tables

In remote applications, a special register can be referenced with a value from the profile attributes table. In addition to general rules, there are rules specific to using special registers set in profiles.

Changing register values

A rollback operation has no effect on the values of special registers.

SET statements for the following special registers can be specified in DSN_PROFILE_ATTRIBUTES table with the SPECIAL_REGISTER keyword. For detailed instructions, see [Setting special registers by using profile tables \(Db2 Administration Guide\)](#).

SET special register statement	Profile-specific considerations
“SET CURRENT ACCELERATOR statement” on page 2129	
“SET CURRENT APPLICATION COMPATIBILITY statement” on page 2130	
“SET CURRENT DEBUG MODE statement” on page 2133	
“SET CURRENT DECFLOAT ROUNDING MODE statement” on page 2134	
“SET CURRENT DEGREE statement” on page 2136	
“SET CURRENT EXPLAIN MODE statement” on page 2137	
“SET CURRENT GET_ACCEL_ARCHIVE statement” on page 2138	

⁸ Whether the SET DATE command affects these special registers depends on the system level and the program temporary fix (PTF) level of the system.

SET special register statement	Profile-specific considerations
“ SET CURRENT LOCALE LC_CTYPE statement” on page 2139	The following syntax variations are not supported in profiles: <ul style="list-style-type: none"> • CURRENT LC_CTYPE • CURRENT_LC_CTYPE
“ SET CURRENT MAINTAINED TABLE TYPES FOR OPTIMIZATION statement” on page 2141	The following syntax variations are not supported in profiles: <ul style="list-style-type: none"> • CURRENT MAINTAINED TYPES • CURRENT MAINTAINED TYPES FOR OPTIMIZATION
“ SET CURRENT OPTIMIZATION HINT statement” on page 2142	
“ SET CURRENT PACKAGE PATH statement” on page 2143	
“ SET CURRENT PRECISION statement” on page 2148	
“ SET CURRENT QUERY ACCELERATION statement” on page 2148	
“ SET CURRENT QUERY ACCELERATION WAITFORDATA statement” on page 2150	
“ SET CURRENT REFRESH AGE statement” on page 2153	The value 99999999999999 is not supported. Use the value ANY instead.
“ SET CURRENT ROUTINE VERSION statement” on page 2154	
“ SET CURRENT RULES statement” on page 2156	
“ SET CURRENT SQLID statement” on page 2156	If the SET CURRENT SQLID statement is run in a stored procedure or user-defined function package that has a dynamic SQL behavior other than run behavior, the SET CURRENT SQLID statement does not affect the authorization ID that is used for dynamic SQL statements in the package. The dynamic SQL behavior determines the authorization ID. For more information, see DYNAMICRULES bind option (Db2 Commands).
“ SET CURRENT TEMPORAL BUSINESS_TIME statement” on page 2158	
“ SET CURRENT TEMPORAL SYSTEM_TIME statement” on page 2160	
“ SET ENCRYPTION PASSWORD statement” on page 2161	
“ SET PATH statement” on page 2163	

SET special register statement	Profile-specific considerations
“SET SCHEMA statement” on page 2166	The following syntax variations are not supported in profiles: <ul style="list-style-type: none"> • CURRENT_SCHEMA (with underscore)
“SET SESSION TIME ZONE statement” on page 2168	The following syntax variations are not supported in profiles: <ul style="list-style-type: none"> • TIMEZONE • TIME ZONE • SESSION TIMEZONE

The following rules apply for the SET statements for special registers:

- An equal sign (=) must be specified between the special register name and the value that is assigned.
- The value that is specified for assignment must be valid for the special register.
- The value must not be an expression, or reference other special registers or variables, unless the statement is SET CURRENT PACKAGE PATH.
- The value that is specified for assignment is passed through this interface as a literal string, unless the statement is SET CURRENT PACKAGE PATH. For example, if a value to be assigned is the same as the name of a special register, Db2 stores the special register name, and not the special register value.
- The maximum length of a SET statement is 1024 bytes.
- The statement must be a Unicode string and encoded with the appropriate CCSID for the application.

Special register values that are set through the profile table take precedence over values that are set by the application before the first non-SET SQL statement. For example, values set by a profile override values that are set through a client connection or data source properties when the connection is first established. The special register values persist for the lifetime of the connection unless the application explicitly sets the special register. Special register values that are set explicitly by the application take precedence over values that are set by the profile table facility and values that are set by the client connection and data source properties. System directed connections, such as three-part name references, use the values of the special registers of the requesting Db2 site. For example, if a Java application establishes a connection to Db2 site 1, the special register values are established with the profile tables from site 1. Later, if the application runs an SQL statement with an implicit three-part name connection to Db2 site 2, then the special register values that are established on site 1 are referenced when the SQL statement runs on site 2.

Special register values that are set through the profile table facility observe the existing rules for inheritance within a routine as defined by INHERIT SPECIAL REGISTERS or DEFAULT SPECIAL REGISTERS routine options. After a user-defined function or a stored procedure completes, Db2 restores all special registers to the values they had before invocation.

As with other special register behavior, commits and rollbacks do not change special register values regardless of how they were established.

Related tasks

[Monitoring and controlling Db2 by using profile tables \(Db2 Administration Guide\)](#)

Related reference

[Special registers](#)

A special register is a storage area that is defined for an application process by Db2 and is used to store information that can be referenced in SQL statements. A reference to a special register is a reference to a value provided by the current server. If the value is a string, its CCSID is a default CCSID of the current server.

[Profile tables \(Db2 Performance\)](#)

CURRENT ACCELERATOR special register

The CURRENT ACCELERATOR special register specifies a preferred target accelerator or accelerators to which Db2 sends dynamic SQL queries.

The CURRENT ACCELERATOR special register applies only to dynamic SQL queries. For static SQL queries, you can use the ACCELERATOR bind option to specify a particular accelerator.

If you have multiple accelerators on which the same set of Db2 tables are accelerated, by default the workload balancing algorithm (WLB) distributes the queries based on the queue length on each accelerator. When the CURRENT ACCELERATOR special register names a particular eligible accelerator server, Db2 considers sending eligible SQL to that server before it sends it to other accelerator servers. If the accelerator server that is named by the CURRENT ACCELERATOR isn't available, Db2 considers other available accelerator servers.

[FL 509](#) For executing DML statements on an accelerator-only table that is defined in multiple accelerators, the CURRENT ACCELERATOR special register must specify one of the accelerators in which the table is defined.

Specifying a particular target accelerator is useful in the following situations:

- To direct queries to different accelerators based on the priorities of the workload. You can direct higher priority queries to the fastest, highest capacity accelerator, and you can direct lower priority queries to a slower accelerator.
- To avoid increased elapsed times that can occur when queries are sent to a remote accelerator. The WLB algorithm doesn't address the latency that occurs when a query is sent to a remote accelerator. If your environment includes both locally deployed accelerators and remote accelerators (for example, for disaster recovery), you can send higher priority queries to a local accelerator.

The data type is VARCHAR(8).

The initial value of CURRENT ACCELERATOR is determined by one of the following settings:

- If specified for the bind of a package, the ACCELERATOR bind option. This bind option does not have a default value.
- Otherwise, the default setting of CURRENT ACCELERATOR is blank (no preferred accelerator).

Example

The following statement sets the CURRENT ACCELERATOR special register so that ACCEL1 is the preferred accelerator.

```
SET CURRENT ACCELERATOR = ACCEL1;
```

Related reference

[“SET CURRENT ACCELERATOR statement” on page 2129](#)

The SET CURRENT ACCELERATOR statement changes the value of the CURRENT ACCELERATOR special register.

[ACCELERATOR bind option \(Db2 Commands\)](#)

CURRENT APPLICATION COMPATIBILITY special register

CURRENT APPLICATION COMPATIBILITY specifies the application compatibility level support for dynamic SQL statements in packages.

The data type is VARCHAR(10).

Set the value with the SET CURRENT APPLICATION COMPATIBILITY statement.

For packages, the initial value is determined by the value of the APPLCOMPAT bind option. For a user-defined function or stored procedures, the initial value is inherited according to the rules in [“Special registers in a user-defined function or a stored procedure” on page 215](#). For advanced triggers, the initial value is V12R1.

The following CURRENT APPLICATION COMPATIBILITY values are supported to specify the application compatibility behavior of dynamic SQL statements:

VvvRrMmmm

Compatibility with the behavior of the identified Db2 function level. For example, V12R1M510 specifies compatibility with the highest available Db2 12 function level. The equivalent function level or higher must be activated.

For the new capabilities that become available in each application compatibility level, see:

- [SQL changes in Db2 13 application compatibility levels](#)
- [SQL changes in Db2 12 application compatibility levels](#)

Tip: Extra program preparation steps might be required to increase the application compatibility level for applications that use data server clients or drivers to access Db2 for z/OS. For more information, see [Setting application compatibility levels for data server clients and drivers \(Db2 Application programming and SQL\)](#).

V12R1

Compatibility with the behavior of Db2 12 function level 500. This value has the same result as specifying V12R1M500.

V11R1

Compatibility with the behavior of Db2 11 new-function mode. After migration to Db2 12, this value has the same result as specifying V12R1M100. For more information, see [V11R1 application compatibility level \(Db2 Application programming and SQL\)](#)

V10R1

Compatibility with the behavior of DB2 10 new-function mode. For more information, see [V10R1 application compatibility level \(Db2 Application programming and SQL\)](#).

Example

The following statement sets the host variable CS to the compatibility level.

```
EXEC SQL SET :CS = CURRENT APPLICATION COMPATIBILITY;
```

Related reference

[BIND and REBIND options for packages, plans, and services \(Db2 Commands\)](#)

[SET CURRENT APPLICATION COMPATIBILITY statement](#)

The SET CURRENT APPLICATION COMPATIBILITY statement assigns a value to the CURRENT APPLICATION COMPATIBILITY special register. This special register allows users to control the package compatibility level behavior for dynamic SQL.

[APPL COMPAT LEVEL field \(APPLCOMPAT subsystem parameter\) \(Db2 Installation and Migration\)](#)

[-ACTIVATE command \(Db2\) \(Db2 Commands\)](#)

CURRENT APPLICATION ENCODING SCHEME special register

CURRENT APPLICATION ENCODING SCHEME specifies which encoding scheme is to be used for dynamic statements. It allows an application to indicate the encoding scheme that is used to process data. This register is not supported in REXX applications or in stored procedures written in REXX.

The value contained in the special register is a character representation of a CCSID. Although you can use the values ASCII, EBCDIC, or UNICODE to set the special register, what is stored in the special register is a character representation of the numeric CCSID that corresponds to the value used in the SET CURRENT APPLICATION ENCODING SCHEME statement. The value ASCII, EBCDIC, or UNICODE is not stored. The CCSID_ENCODING scalar function can be used to get a value of ASCII, EBCDIC, or UNICODE from a numeric CCSID value.

The data type is CHAR(8). If necessary, the value is padded on the right with blanks so that its length is 8 bytes.

For stored procedures and user-defined functions, the initial value of the CURRENT APPLICATION ENCODING SCHEME special register is determined by the value of the ENCODING bind option for the package that is associated with the procedure or function, or by the APPLICATION ENCODING SCHEME option of the CREATE FUNCTION, ALTER FUNCTION, CREATE PROCEDURE, or ALTER PROCEDURE statement for a compiled SQL function or a native SQL procedure. If the option was not specified, the initial value is the value of the field DEFAULT APPLICATION ENCODING SCHEME field on installation panel DSNTIPF.

For basic triggers, the initial value of the CURRENT APPLICATION ENCODING SCHEME special register is Unicode. For advanced triggers, the initial value of the CURRENT APPLICATION ENCODING SCHEME special register is the value of field DEFAULT APPLICATION ENCODING SCHEME on installation panel DSNTIPF.

Example

The CURRENT APPLICATION ENCODING SCHEME special register can be used like any other special register:

```
EXEC SQL VALUES(CURRENT APPLICATION ENCODING SCHEME) INTO :HV1;
EXEC SQL INSERT INTO T1 VALUES (CURRENT APPLICATION ENCODING SCHEME);
EXEC SQL SET :HV1 = CURRENT APPLICATION ENCODING SCHEME;
EXEC SQL SELECT C1 FROM T1 WHERE C1 = CURRENT APPLICATION ENCODING SCHEME;
```

Related reference

SET CURRENT APPLICATION ENCODING SCHEME

The SET CURRENT APPLICATION ENCODING SCHEME statement assigns a value to the CURRENT APPLICATION ENCODING SCHEME special register. This special register allows users to control which encoding scheme will be used for dynamic SQL statements after the SET statement has been executed.

CURRENT CLIENT_ACCTNG special register

CURRENT CLIENT_ACCTNG contains the value of the accounting string from the client information that is specified for the connection.

The data type is VARCHAR(255).

The value of the special register can be changed by using one of the following application programming interfaces (APIs):

- Set Client Information (sqleseti)
- SQLSetConnectAttr (ODBC)
- java.sql.Connection.setClientInfo (JDBC)
- The RRS DSNRLI SIGNON, AUTH SIGNON, CONTEXT SIGNON, or SET_CLIENT_ID function
- The WLM_SET_CLIENT_INFO stored procedure

The value for the accounting string will be obtained first from the accounting string that is set by the SET_CLIENT_ID function, AUTH SIGNON function, or the Set Client Information (sqleseti) API, or alternatively from the accounting token set by RRSAF if accounting string has not been set.

The application compatibility value of the package determines the length and blank padding of the CURRENT CLIENT_ACCTNG special register returned.

If one of these APIs is not used to set the value of the special register, an empty string is returned when the special register is referenced.

CICS attachment facility

For CICS tasks that access Db2, the CICS attachment facility normally does not pass an accounting string to Db2, unless the origin data for the CICS task contains adapter data that specifies the origin of

the CICS task. If origin adapter data is present, the CICS attachment facility passes the data to Db2, preceded by an eye-catcher. For example:

```
CICS_ORIGIN_DATA:ADAPTER_DATA_1_2_3:adapter-data
```

adapter-data is the origin adapter data.

Example:

The following statement assigns the current value of the accounting string for a connection to host variable :ACCT_STRING.

```
SET :ACCT_STRING = CURRENT CLIENT_ACCTNG
```

Related concepts

[RRSAF connection functions \(Db2 Application programming and SQL\)](#)

[Application compatibility levels in Db2 12 \(Db2 Application programming and SQL\)](#)

Related tasks

[Providing extended client information to the data source with IBM Data Server Driver for JDBC and SQLJ-only methods \(Db2 Application Programming for Java\)](#)

Related reference

[WLM_SET_CLIENT_INFO stored procedure](#)

This procedure allows the caller to set client information that is associated with the current connection at the Db2 for z/OS server.

[sqle_client_info data structure](#)

CURRENT CLIENT_APPLNAME special register

CURRENT CLIENT_APPLNAME contains the value of the application name from the client information that is specified for the connection.

The data type is VARCHAR(255).

The default application name varies, depending on the connection:

- If the connection is from a remote application client driver, the default is the application name as supplied by the driver. Default values set by the IBM Data Server Driver for JDBC and SQLJ can be obtained from the DatabaseMetaData.getClientInfoProperties method.
- If the connection is from a remote Db2 12 for z/OS application, the default varies depending on which attachment facility is used:

TSO attachment facility

The default application name is one of the following cases:

- The TSO logon user ID when the application runs in TSO foreground using TSO online applications like SPUFI.
- The job name when the application runs in TSO background using TSO batch applications like DSNTEP2.

RRS attachment facility interface

The correlation ID that is provided at the call of the RRS DSNRLI SIGNON function.

Call attachment facility

The job name.

CICS attachment facility

If the origin data for the CICS task contains adapter data that indicates the origin of the CICS task, the CICS attachment facility passes the following items to Db2:

- An eye-catcher string
- The ID of the adapter that set the origin data

That information is used as the default application name. For example:

```
CICS_ORIGIN_DATA:ADAPTER_ID: name
```

name is one of the following values:

- IBM_zOS_Connect_CICS_SP for a CICS task that was initiated as a result of an inbound request from z/OS Connect
- IBM WebSphere MQ for z/OS for a CICS task that was initiated by the CICS-MQ trigger monitor or CICS-MQ bridge

If there is no adapter data in the CICS origin data, no data is passed from CICS to Db2. Db2 uses the first 8 bytes of the correlation ID. In particular, the correlation ID is a 12-byte string for a CICS transaction, where the first 8 bytes are used as the default application name.

IMS Attachment facility

An 8-byte string, the Program Specification Block (PSB) name, or the program name.

The value of the special register can be changed by using one of the following application programming interfaces (APIs):

- `SQL_CLIENT_INFO_APPLNAME` (sqleseti)
- `SQLSetConnectAttr` (ODBC)
- `java.sql.Connection.setClientInfo` (JDBC)
- The RRS DSNRLI SIGNON, AUTH SIGNON, CONTEXT SIGNON, or `SET_CLIENT_ID` function
- The `WLM_SET_CLIENT_INFO` stored procedure

When the client application name is explicitly set, it overwrites the default application name described above and is used as the client application name.

The application compatibility value of the package determines the length and blank padding of the `CURRENT_CLIENT_APPLNAME` special register returned.

If one of these APIs is not used to set the value of the special register, an empty string is returned when the special register is referenced.

Monitoring remote application statistics based on `CURRENT_CLIENT_APPLNAME` (IFCID 411)

You can use start a trace that includes statistics class 10 (IFCID 411) to monitor statistics for remote DRDA applications based on the `CURRENT_CLIENT_APPLNAME` special register. For more information, see [Statistics trace \(Db2 Performance\)](#).

Important: Monitoring of applications with IFCID 411 is limited to 6000 unique user ID values. If this limit is exceeded, Db2 issues DSNL030I with reason code 00D3105D and stops collecting the statistics for any new application names until DDF is restarted. For best results, use `CLIENT_CORR_TOKEN` special register to identify individual connections.

Example

Select the departments that are allowed to use the application that is being used in this connection.

```
SELECT DEPT
FROM DEPT_APPL_MAP
WHERE APPL_NAME = CURRENT_CLIENT_APPLNAME
```

Related concepts

[RRSAF connection functions \(Db2 Application programming and SQL\)](#)

[Application compatibility levels in Db2 12 \(Db2 Application programming and SQL\)](#)

Related tasks

[Providing extended client information to the data source with IBM Data Server Driver for JDBC and SQLJ-only methods \(Db2 Application Programming for Java\)](#)

Related reference

[WLM_SET_CLIENT_INFO stored procedure](#)

This procedure allows the caller to set client information that is associated with the current connection at the Db2 for z/OS server.

[sqle_client_info data structure](#)

CURRENT_CLIENT_CORR_TOKEN special register

CURRENT_CLIENT_CORR_TOKEN contains the value of the client correlation token from the client information that is specified for the connection.

The data type is VARCHAR(255).

The value of the special register can be changed by using one of the following application programming interfaces (APIs):

- `SQL_CLIENT_INFO_PROGRAMID` (sqleseti)
- `java.sql.Connection.setClientInfo` (JDBC)
- The RRS DSNRLI SIGNON, AUTH SIGNON, CONTEXT SIGNON, or `SET_CLIENT_ID` function

If one of these APIs is not used to set the value of the special register, the value defaults to the correlation identifier from the client driver such as an application identifier. If a correlation identifier is not provided by the client system, an LUWID (Logical Unit of Work ID) is generated which becomes the correlation token.

Example: Select the departments that are allowed to use the correlation token that is being used in this connection.

```
SELECT DEPT
FROM DEPT_CORR_TOKEN_MAP
WHERE CORR_TOKEN_NAME = CURRENT_CLIENT_CORR_TOKEN
```

Related concepts

[RRSAF connection functions \(Db2 Application programming and SQL\)](#)

Related tasks

[Providing extended client information to the data source with IBM Data Server Driver for JDBC and SQLJ-only methods \(Db2 Application Programming for Java\)](#)

Related reference

[WLM_SET_CLIENT_INFO stored procedure](#)

This procedure allows the caller to set client information that is associated with the current connection at the Db2 for z/OS server.

[sqle_client_info data structure](#)

CURRENT_CLIENT_USERID special register

CURRENT_CLIENT_USERID contains the value of the client user ID from the client information that is specified for the connection.

The default client user ID is the primary authorization ID used to establish the connection.

The data type is VARCHAR(255).

The value of the special register can be changed by using one of the following application programming interfaces (APIs):

- `SQL_CLIENT_INFO_USERID` (sqleseti)
- `SQLSetConnectAttr` (ODBC)

- `java.sql.Connection.setClientInfo` (JDBC)
- The RRS DSNRLI SIGNON, AUTH SIGNON, CONTEXT SIGNON, or `SET_CLIENT_ID` function
- The `WLM_SET_CLIENT_INFO` stored procedure

When the client user ID is explicitly set, it overwrites the primary authorization id described above and is used as the client user ID.

If the value set by the API exceeds 128 bytes, it is truncated to 128 bytes.

The application compatibility value of the package determines the length and blank padding of the `CURRENT CLIENT_USERID` special register returned.

Monitoring remote user statistics based on `CURRENT CLIENT_USERID` (IFCID 412)

You can start a trace that includes statistics class 11 (IFCID 412) to monitor statistics for remote DRDA users based on the `CURRENT CLIENT_USERID` special register. For more information, see [Statistics trace \(Db2 Performance\)](#).

Important: Monitoring of applications with IFCID 412 is limited to 6000 unique user ID values. If this limit is exceeded, Db2 issues DSNL030I with reason code 00D3105E and stops collecting the statistics for any new user IDs until DDF is restarted. For best results, use the `CLIENT_CORR_TOKEN` special register to identify individual connections.

Example

Find out in which department the current client user ID works.

```
SELECT DEPT
FROM DEPT_USERID_MAP
WHERE USER_ID = CURRENT CLIENT_USERID
```

Related concepts

[RRSAF connection functions \(Db2 Application programming and SQL\)](#)

[Application compatibility levels in Db2 12 \(Db2 Application programming and SQL\)](#)

Related tasks

[Providing extended client information to the data source with IBM Data Server Driver for JDBC and SQLJ-only methods \(Db2 Application Programming for Java\)](#)

Related reference

[WLM_SET_CLIENT_INFO stored procedure](#)

This procedure allows the caller to set client information that is associated with the current connection at the Db2 for z/OS server.

[sqlc_client_info data structure](#)

[Client info properties support by the IBM Data Server Driver for JDBC and SQLJ \(Db2 Application Programming for Java\)](#)

`CURRENT CLIENT_WRKSTNAME` special register

`CURRENT CLIENT_WRKSTNAME` contains the value of the workstation name from the client information that is specified for the connection.

The data type is `VARCHAR(255)`.

The default workstation name varies, depending on the connection:

- If the connection originates from a Db2 12 for z/OS requester, it is the client hostname.
- If the connection is from a remote application client driver, it is the client hostname where the request is submitted. Default values that are set by the IBM Data Server Driver for JDBC and SQLJ can be obtained from the `DatabaseMetaData.getClientInfoProperties` method.
- If the connection is from a remote Db2 12 for z/OS application, the default varies depending on which attachment facility is used:

TSO attachment facility

The default workstation name is one of the following cases:

- The default workstation name is 'TSO' when the application runs in TSO foreground with TSO online applications like SPUFI.
- The default workstation name is 'BATCH' when the application runs in TSO background with TSO batch applications like DSNTEP2.

RRS attachment facility interface

The default workstation name is 'RRSAF'

Call attachment facility

The default workstation name is 'DB2CALL'.

CICS attachment facility

The default workstation name is the CICS region name.

IMS Attachment facility

The default workstation name is IMS region ID.

The value of the special register can be changed by using one of the following application programming interfaces (APIs):

- `SQLC_CLIENT_INFO_WRKSTNNAME` (`sqlcseti`)
- `SQLSetConnectAttr` (ODBC)
- `java.sql.Connection.setClientInfo` (JDBC)
- The RRS DSNRLI SIGNON, AUTH SIGNON, CONTEXT SIGNON, or `SET_CLIENT_ID` function
- The `WLM_SET_CLIENT_INFO` stored procedure

When the client workstation name is explicitly set, it overwrites the default workstation name described above and is used as the client workstation name.

The application compatibility value of the package determines the length and blank padding of the `CURRENT_CLIENT_WRKSTNNAME` special register returned.

If one of these APIs is not used to set the value of the special register, an empty string is returned when the special register is referenced.

Example: Get the name of the workstation that is being used in this connection.

```
SET :WS_NAME = CURRENT_CLIENT_WRKSTNNAME
```

Related concepts

[RRSAF connection functions \(Db2 Application programming and SQL\)](#)

[Application compatibility levels in Db2 12 \(Db2 Application programming and SQL\)](#)

Related tasks

[Providing extended client information to the data source with IBM Data Server Driver for JDBC and SQLJ-only methods \(Db2 Application Programming for Java\)](#)

Related reference

[WLM_SET_CLIENT_INFO stored procedure](#)

This procedure allows the caller to set client information that is associated with the current connection at the Db2 for z/OS server.

[sqlc_client_info data structure](#)

[Client info properties support by the IBM Data Server Driver for JDBC and SQLJ \(Db2 Application Programming for Java\)](#)

CURRENT DATE special register

The CURRENT DATE special register specifies a date that is based on a reading of the time-of-day clock when the SQL statement is executed at the current server.

If this special register is used more than one time within a single SQL statement, or used with CURRENT TIME or CURRENT TIMESTAMP within a single statement, all values are based on a single clock reading.⁹

The value of CURRENT DATE in a user-defined function or stored procedure is inherited according to the rules in [Table 47 on page 215](#). For other applications, the date is derived by the Db2 that executes the SQL statement that refers to the special register. For a description of how the date is derived, see [Datetime special registers](#).

Specifying CURRENT_DATE is equivalent to specifying CURRENT DATE.

Example

Display the average age of employees.

```
SELECT AVG(YEAR(CURRENT DATE - BIRTHDATE))
FROM DSN8C10.EMP;
```

CURRENT DEBUG MODE special register

CURRENT DEBUG MODE specifies the default value for the DEBUG MODE option when advanced triggers and certain routines are created. The DEBUG MODE option specifies whether the trigger or routine should be built with the ability to run in debugging mode.

CURRENT DEBUG MODE specifies the default value for the DEBUG MODE option of the following statements:

- ALTER FUNCTION for a new version of an SQL scalar function
- ALTER PROCEDURE for a new version of a native SQL procedure
- ALTER TRIGGER (advanced) for a new version of a trigger
- CREATE FUNCTION for an SQL scalar function
- CREATE PROCEDURE for a Java procedure
- CREATE PROCEDURE for a native SQL procedure
- CREATE TRIGGER (advanced) for an advanced trigger

The data type is VARCHAR(8). The following values are valid:

- ALLOW — Specifies that the routine or trigger can be run in debugging mode.
- DISALLOW — Specifies that the routine or trigger cannot be run in debugging mode. A subsequent ALTER statement can change the DEBUG MODE option to allow the routine or trigger to run in debugging mode.
- DISABLE — Specifies that the routine or trigger can never be run in debugging mode. When DISABLE is in effect, the routine or trigger cannot be changed to run in debugging mode. A subsequent ALTER statement cannot change the DEBUG MODE option to allow or disallow the routine or trigger to run in debugging mode.

The value of CURRENT DEBUG MODE in a user-defined function, stored procedure, or trigger is determined according to the rules in [Table 47 on page 215](#). In other contexts the initial value of CURRENT DEBUG MODE is DISALLOW.

You can change the value of the CURRENT DEBUG MODE special register by running the SET CURRENT DEBUG MODE statement.

⁹ Except for the case of a non-atomic multiple row INSERT or MERGE statement.

Example

The following statement sets the host variable `DEBUG_MODE_OPT` to the value of the `CURRENT DEBUG MODE` special register.

```
VALUES CURRENT DEBUG MODE INTO :DEBUG_MODE_OPT;
```

Related reference

[SET CURRENT DEBUG MODE statement](#)

The `SET CURRENT DEBUG MODE` statement assigns a value to the `CURRENT DEBUG MODE` special register.

CURRENT DECFLOAT ROUNDING MODE special register

`CURRENT DECFLOAT ROUNDING MODE` specifies the default rounding mode that is used for `DECFLOAT` values.

The data type is `VARCHAR(128)`. The following rounding modes are supported:

- `ROUND_CEILING` — rounds the value towards positive infinity. If all of the discarded digits are zero or if the sign is negative the result is unchanged other than the removal of the discarded digits. Otherwise, the result coefficient is incremented by 1.
- `ROUND_DOWN` — rounds the value towards 0 (truncation). The discarded digits are ignored.
- `ROUND_FLOOR` — rounds the value towards negative infinity. If all of the discarded digits are zero or if the sign is positive the result is unchanged other than the removal of discarded digits. Otherwise, the sign is negative and the result coefficient is incremented by 1.
- `ROUND_HALF_DOWN` — rounds the value to the nearest value; if the values are equidistant, rounds the value towards zero. If the discarded digits represent greater than half (0.5) of the value of a one in the next left position then the result coefficient is incremented by 1. Otherwise the discarded digits are ignored. This rounding mode is not recommended when creating a portable application because it is not supported by the IEEE draft standard for floating-point arithmetic.
- `ROUND_HALF_EVEN` — rounds the value to the nearest value; if the values are equidistant, rounds the value so that the final digit is even. If the discarded digits represents greater than half (0.5) of the value of one in the next left position then the result coefficient is incremented by 1. If they represent less than half, then the result coefficient is not adjusted (that is, the discarded digits are ignored). Otherwise the result coefficient is unaltered if its rightmost digit is even, or is incremented by 1 if its rightmost digit is odd (to make an even digit).
- `ROUND_HALF_UP` — rounds the value to the nearest value; if the values are equidistant, rounds the value away from zero. If the discarded digits represent greater than or equal to half (0.5) of the value of one in the next left position then the result coefficient is incremented by 1. Otherwise the discarded digits are ignored.
- `ROUND_UP` — rounds the value away from 0. If all of the discarded digits are zero the result is unchanged other than the removal of discarded digits. Otherwise, the result coefficient is incremented by 1. This rounding mode is not recommended when creating a portable application because it is not supported by the IEEE draft standard for floating-point arithmetic.

The initial value of `CURRENT DECFLOAT ROUNDING MODE` is the value of the `ROUNDING` bind option or the native SQL procedure option. If the `ROUNDING` option is not specified, the initial value is the value of the `DEF DECFLOAT ROUND MODE` field on installation panel `DSNTIPF`.

The value of `CURRENT DECFLOAT ROUNDING MODE` in a user-defined function or stored procedure is inherited according to the rules in [Table 47 on page 215](#).

You can change the value of the `CURRENT DECFLOAT ROUNDING MODE` by executing the statement `SET CURRENT DECFLOAT ROUNDING MODE`.

Example: Set the `DECFLOAT` rounding mode to `ROUND_CEILING`:

```
SET CURRENT DECFLOAT ROUNDING MODE = 'ROUND_CEILING';
```

Related reference

[SET CURRENT DECFLOAT ROUNDING MODE statement](#)

The SET CURRENT DECFLOAT ROUNDING MODE statement assigns a value to the CURRENT DECFLOAT ROUNDING MODE special register. The special register sets the default rounding mode that is used with decimal floating point values (DECFLOAT).

CURRENT DEGREE special register

CURRENT DEGREE specifies the degree of parallelism for the execution of queries that are dynamically prepared by the application process.

The data type of the register is CHAR(3) and the only valid values are 1 (padded on the right with two blanks) and ANY.

If the value of CURRENT DEGREE is 1 when a query is dynamically prepared, the execution of that query will not use parallelism. If the value of CURRENT DEGREE is ANY when a query is dynamically prepared, the execution of that query can involve parallelism.

The initial value of CURRENT DEGREE is determined by the value of field CURRENT DEGREE on installation panel DSNTIP8. The default for the initial value of that field is 1 unless your installation has changed it to be ANY by modifying the value in that field. The initial value of CURRENT DEGREE in a user-defined function or stored procedure is inherited according to the rules in [Table 47 on page 215](#).

You can change the value of the register by executing the statement SET CURRENT DEGREE.

CURRENT DEGREE is a register at the database server. Its value applies to queries that are dynamically prepared at that server and to queries that are dynamically prepared at another Db2 subsystem as a result of the use of a Db2 private connection between that server and that Db2 subsystem.

Example: The following statement inhibits parallelism:

```
SET CURRENT DEGREE = '1';
```

Related concepts

[Parallel processing \(Db2 Performance\)](#)

Related tasks

[Enabling parallel processing \(Db2 Performance\)](#)

[Disabling query parallelism \(Db2 Performance\)](#)

Related reference

[SET CURRENT DEGREE statement](#)

The SET CURRENT DEGREE statement assigns a value to the CURRENT DEGREE special register.

[CURRENT DEGREE field \(CDSSRDEF subsystem parameter\) \(Db2 Installation and Migration\)](#)

CURRENT EXPLAIN MODE special register

The CURRENT EXPLAIN MODE special register contains the values that control the EXPLAIN behavior in regards to eligible dynamic SQL statements.

This facility generates and inserts EXPLAIN information into the EXPLAIN tables. Possible values for the CURRENT EXPLAIN MODE special register are YES, NO, and EXPLAIN. The data type is VARCHAR(128).

NO

Disable the ability to use EXPLAIN. No EXPLAIN information is kept. NO is the initial value of the EXPLAIN MODE special register.

YES

Enables the EXPLAIN facility and causes EXPLAIN information to be inserted into the EXPLAIN tables for eligible dynamic SQL statements after the statement is prepared and executed. All dynamic SQL statements are compiled and executed normally.

EXPLAIN

Enables the EXPLAIN facility and causes EXPLAIN information to be captured for any eligible dynamic SQL statement after the statement is prepared. This setting behaves similarly to YES, however, dynamic statements, except for SET statements, are not executed.

For values YES and EXPLAIN, prepared statements are not saved into the dynamic statement cache.

The initial value is NO. The initial value of CURRENT EXPLAIN MODE in a user-defined function or stored procedure is inherited according to the rules in [“Special registers in a user-defined function or a stored procedure”](#) on page 215.

The value can be changed using the SET CURRENT EXPLAIN MODE statement.

Prerequisites for using CURRENT EXPLAIN MODE:

- Both the PLAN_TABLE and DSN_STATEMENT_CACHE_TABLE exist on the Db2 server and the table names are qualified with the current SQLID that is used when running the application.
- The Dynamic statement cache is enabled.
- The client application contains some explainable statements.

Required authorization for using CURRENT EXPLAIN MODE:

If CURRENT EXPLAIN MODE is set to YES or EXPLAIN, the privilege set for the underlying statement must have the necessary authorization to use the EXPLAIN facility.

When the EXPLAIN privilege is in effect and CURRENT EXPLAIN MODE is set to EXPLAIN, any SQLCODE that is returned due to the EXPLAIN privilege override any SQLCODE that is returned due to CURRENT EXPLAIN MODE being set to EXPLAIN.

Considerations when using the CURRENT EXPLAIN MODE special register to explain the acceleration of rowset queries:

A rowset query cannot be passed to an accelerator server for processing in the following cases:

- If the rowset query is run remotely
- If the rowset query is declared WITH RETURN
- If the rowset query is run under an SQL PL routine

When a rowset query is run with the CURRENT EXPLAIN MODE special register set to YES or EXPLAIN, the EXPLAIN output indicates whether the local execution of a rowset cursor can be accelerated, depending on the content of the query. The EXPLAIN output will always indicate that remote rowset queries, rowset queries that are declared WITH RETURN, and rowset queries that run under an SQL PL routine cannot be accelerated.

Related reference

[SET CURRENT EXPLAIN MODE statement](#)

The SET CURRENT EXPLAIN MODE statement assigns a value to the CURRENT EXPLAIN MODE special register.

CURRENT GET_ACCEL_ARCHIVE special register

The CURRENT GET_ACCEL_ARCHIVE special register specifies whether a dynamic SQL query that references a table that is archived on an accelerator server uses the archived data. The special register does not apply to static SQL queries.

The data type is VARCHAR(255).

Valid values are:

NO

Specifies that if a table is archived on an accelerator server, and a query references that table, the query does not use the data that is archived.

YES

Specifies that if a table is archived on an accelerator server, and a query references that table, the query uses the data that is archived.

The initial value of CURRENT GET_ACCEL_ARCHIVE is determined by one of the following settings:

- The value of Db2 subsystem parameter GET_ACCEL_ARCHIVE. The default for the initial value of that subsystem parameter is NO unless your installation has changed the value.
- If specified for the bind of a package, the GETACCELARCHIVE bind option. This behavior enables the GETACCELARCHIVE bind option to be used to specify the acceleration archive behavior for dynamic SQL queries and not only static SQL queries. This bind option does not have a default value.

The initial value of CURRENT GET_ACCEL_ARCHIVE in a user-defined function or stored procedure is inherited according to the rules in [“Special registers in a user-defined function or a stored procedure”](#) on page 215.

You can change the value of the register by executing the SET CURRENT GET_ACCEL_ARCHIVE statement.

The precedence order (lowest to highest) for setting the value of the special register is as follows:

- The GET_ACCEL_ARCHIVE subsystem parameter
- The GETACCELARCHIVE bind option, if specified
- An explicit SET CURRENT GET_ACCEL_ARCHIVE statement

Example: The following statement sets the CURRENT GET_ACCEL_ARCHIVE special register so that when a table is archived on an accelerator server, the table reference does not include the archived data.

```
SET CURRENT GET_ACCEL_ARCHIVE=NO;
```

Related tasks

[Enabling acceleration of SQL queries \(Db2 Performance\)](#)

Related reference

SET CURRENT GET_ACCEL_ARCHIVE statement

The SET CURRENT GET_ACCEL_ARCHIVE statement changes the value of the CURRENT GET_ACCEL_ARCHIVE special register.

CURRENT LOCALE LC_CTYPE special register

CURRENT LOCALE LC_CTYPE specifies the LC_CTYPE locale that will be used to execute SQL statements that use a built-in function that references a locale. Functions LCASE, UCASE, and TRANSLATE (with a single argument) refer to the locale when they are executed.

The data type is CHAR(50). If necessary, the value is padded on the right with blanks so that its length is 50 bytes. The following values are supported:

blank

For a conversion to lowercase, SBCS uppercase characters A-Z are converted to SBCS lowercase characters a-z, and characters with diacritical marks are not converted. If the string contains MIXED or DBCS characters, full-width Latin uppercase characters A-Z are converted to full-width lowercase characters a-z.

For a conversion to uppercase, SBCS lowercase characters a-z are converted to SBCS uppercase characters A-Z, and characters with diacritical marks are not converted. If the string contains MIXED or DBCS characters, full-width Latin lowercase characters a-z are converted to full-width uppercase characters A-Z.

For optimal performance, specify a blank string unless your data must be processed by using rules that are defined by a specific locale.

UNI

Case conversions use both the NORMAL and SPECIAL casing capabilities as described in [Select the conversions \(z/OS: Unicode Services User's Guide and Reference\)](#). UNI cannot be used with EBCDIC data.

UNI_60

The conversion uses Unicode Standard 6.0.0 and the NORMAL casing capability, as described in [Select the conversions \(z/OS: Unicode Services User's Guide and Reference\)](#). You must not specify UNI_60 when *string-expression* is EBCDIC data.

UNI_90

The conversion uses Unicode Standard 9.0.0 and the NORMAL casing capability, as described in [Select the conversions \(z/OS: Unicode Services User's Guide and Reference\)](#). You must not specify UNI_90 when *string-expression* is EBCDIC data.

UNI_SIMPLE

Case conversions use the NORMAL casing capabilities as described in [Select the conversions \(z/OS: Unicode Services User's Guide and Reference\)](#). UNI_SIMPLE cannot be used with EBCDIC data.

locale name

The locale defines the rules for conversion to uppercase or lowercase characters. For information about locales and their naming conventions for EBCDIC data, see [Locale naming conventions \(XL C/C++ Programming Guide\)](#). For information about locales for Unicode and ASCII data, see [z/OS Unicode Services User's Guide and Reference](#).

The initial value of CURRENT LOCALE LC_CTYPE is determined by the value of field LOCALE LC_CTYPE on installation panel DSNTIPF. The default for the initial value of that field is blank unless your installation has changed the value of that field. The initial value of CURRENT LOCALE LC_CTYPE in a user-defined function or stored procedure is inherited according to the rules in [Table 47 on page 215](#).

You can change the value of the register by executing the statement SET CURRENT LOCALE LC_CTYPE.

Some examples of locales for EBCDIC data include:

- Fr_BE
- Fr_FR@EURO
- En_US
- Ja_JP

Example

Save the value of current register CURRENT LOCALE LC_CTYPE in host variable *HV1*, which is defined as VARCHAR(50).

```
EXEC SQL VALUES(CURRENT LOCALE LC_CTYPE) INTO :HV1;
```

Related concepts

[z/OS Unicode Services User's Guide and Reference](#)

Related reference

[SET CURRENT LOCALE LC_CTYPE statement](#)

The SET CURRENT LOCALE LC_CTYPE statement assigns a value to the CURRENT LOCALE LC_CTYPE special register. The special register allows control over the LC_CTYPE locale for statements that use a built-in function that refers to a locale, such as LCASE, UCASE, and TRANSLATE (with a single argument).

[z/OS XL C/C++ Programming Guide](#)

CURRENT MAINTAINED TABLE TYPES FOR OPTIMIZATION special register

CURRENT MAINTAINED TABLE TYPES FOR OPTIMIZATION specifies a value that identifies the types of objects that can be considered to optimize the processing of dynamic SQL queries. This register contains a keyword representing table types.

The data type is VARCHAR(255).

The initial value of CURRENT MAINTAINED TABLE TYPES FOR OPTIMIZATION is determined by the value of field CURRENT MAINT TYPES on installation panel DSNTIP81. The default for the initial value of that field is SYSTEM unless your installation has changed the value of that field. The initial value of CURRENT MAINTAINED TABLE TYPES FOR OPTIMIZATION in a user-defined function or stored procedure is inherited according to the rules in [Table 47 on page 215](#).

You can change the value of the register by executing the SET CURRENT MAINTAINED TABLE TYPES FOR OPTIMIZATION statement. The object types controlled by this special register are never considered by static embedded SQL queries.

Example: Set the CURRENT MAINTAINED TABLE TYPES FOR OPTIMIZATION special register so that all materialized query tables are considered.

```
SET CURRENT MAINTAINED TABLE TYPES ALL;
```

Related reference

[SET CURRENT MAINTAINED TABLE TYPES FOR OPTIMIZATION statement](#)

The SET CURRENT MAINTAINED TABLE TYPES FOR OPTIMIZATION statement changes the value of the CURRENT MAINTAINED TABLE TYPES FOR OPTIMIZATION special register.

CURRENT MEMBER special register

CURRENT MEMBER specifies the member name of a current Db2 data sharing member on which a statement is executing. The value of CURRENT MEMBER is a character string.

The data type is CHAR(8). If necessary, the member name is padded to the right with blanks so that its length is 8 bytes.

The value of a CURRENT MEMBER is a string of blanks when the application process is connected to a Db2 subsystem that is not a member of a data sharing group.

The SQL SET statement cannot change the value of CURRENT MEMBER.

Example: Use one of the following statements to set the host variable MEM to the name of the current Db2 member.

```
EXEC SQL SET :MEM = CURRENT MEMBER;
```

```
EXEC VALUES (CURRENT MEMBER) into :MEM;
```

CURRENT OPTIMIZATION HINT special register

CURRENT OPTIMIZATION HINT specifies the user-defined optimization hint that Db2 should use to generate the access path for dynamic statements.

The data type is VARCHAR(128).

The value of the register identifies the rows in *owner*.PLAN_TABLE that Db2 uses to generate the access path. Db2 uses information in the rows in *owner*.PLAN_TABLE for which the value of the OPTHINT column matches the value of the CURRENT OPTIMIZATION special register. If the value of the register is an empty string or all blanks, Db2 uses normal optimization and ignores optimization hints. If the value of the register includes any non-blank characters and Db2 was installed without optimization hints enabled (field OPTIMIZATION HINTS on installation panel DSNTIP8), a warning occurs.

The initial value of CURRENT OPTIMIZATION HINT is the value of the OPTHINT bind option or of the native SQL procedure option. The initial value of CURRENT OPTIMIZATION HINT in a user-defined function or stored procedure is inherited according to the rules in Table 47 on page 215. You can change the value of the special register by executing the statement SET CURRENT OPTIMIZATION HINT.

Example: Set the CURRENT OPTIMIZATION HINT special register so that Db2 uses the optimization plan hint that is identified by host variable NOHYB when generating the access path for dynamic statements.

```
SET CURRENT OPTIMIZATION HINT = :NOHYB
```

Related tasks

[Specifying access paths in a PLAN_TABLE instance \(Db2 Performance\)](#)

[Preparing to influence access paths \(Db2 Performance\)](#)

Related reference

SET CURRENT OPTIMIZATION HINT statement

The SET CURRENT OPTIMIZATION HINT statement assigns a value to the CURRENT OPTIMIZATION HINT special register.

CURRENT PACKAGE PATH special register

CURRENT PACKAGE PATH specifies a value that identifies the path used to resolve references to packages that are used to execute SQL statements. This special register applies to both static and dynamic statements.

The data type is VARCHAR(4096). The value can be an empty or blank string, or a list of one or more collection IDs, where the collection IDs are enclosed in double quotation marks and separated by commas. Any quotation marks within the string are repeated as they are in any delimited identifier. The delimiters and commas are included in the length of the special register.

The initial value of CURRENT PACKAGE PATH is an empty string. The value is a list of collections only if the application process has explicitly specified a list of collections by means of the SET CURRENT PACKAGE PATH statement.

The initial value of CURRENT PACKAGE PATH in a user-defined function or procedure is inherited according to the rules in [Table 47 on page 215](#).

When CURRENT PACKAGE PATH or CURRENT PACKAGESET is set, Db2 uses the values in these registers to resolve the collection for a package. The value of CURRENT PACKAGE PATH takes priority over CURRENT PACKAGESET. In a distributed environment, the value of CURRENT PACKAGE PATH at the remote server takes precedence of the value of CURRENT PACKAGE PATH at the local server (the requester). For more information on package resolution, see [Binding an application plan \(Db2 Application programming and SQL\)](#).

Example: In an application that is using SQLJ packages (in collection SQLJ1 and SQLJ2) and a JDBC package in DB2JAVA, set the CURRENT PACKAGE PATH special register to check SQLJ1 first, followed by SQLJ2, and DB2JAVA:

```
SET CURRENT PACKAGE PATH = SQLJ1, SQLJ2, DB2JAVA;
```

The following statement sets the host variable to the value of the resulting list:

```
SET :HVPKLIST = CURRENT PACKAGE PATH;
```

The value of the host variable would be "SQLJ1", "SQLJ2", "DB2JAVA".

Related reference

SET CURRENT PACKAGE PATH statement

The SET CURRENT PACKAGE PATH statement assigns a value to the CURRENT PACKAGE PATH special register.

CURRENT PACKAGESET special register

CURRENT PACKAGESET specifies an empty string, a string of blanks, or the collection ID of the package that will be used to execute SQL statements.

The data type is VARCHAR(128).

The initial value of CURRENT PACKAGESET is an empty string. The value is a collection ID only if the application process has explicitly specified a collection ID by means of the SET CURRENT PACKAGESET statement.

The initial value of CURRENT PACKAGESET in a user-defined function or stored procedure is inherited according to the rules in [Table 47 on page 215](#).

Example: Before passing control to another program, identify the collection ID for its package as ALPHA.

```
EXEC SQL SET CURRENT PACKAGESET = 'ALPHA';
```

Related reference

[SET CURRENT PACKAGESET statement](#)

The SET CURRENT PACKAGESET statement assigns a value to the CURRENT PACKAGESET special register.

CURRENT PATH special register

CURRENT PATH specifies the SQL path used to resolve unqualified data type names and function names in dynamically prepared SQL statements. It is also used to resolve unqualified procedure names that are specified as host variables in SQL CALL statements (CALL *host-variable*).

The data type is VARCHAR(2048).

The CURRENT PATH special register contains a list of one or more schema names, where each schema name is enclosed in delimiters and separated from the following schema by a comma (any delimiters within the string are repeated as they are in any delimited identifier). The delimiters and commas are included in the 2048 character length.

For information on when the SQL path is used to resolve unqualified names in both dynamic and static SQL statements and the effect of its value, see [“SQL path” on page 85](#).

The initial value of the CURRENT PATH special register is determined from the first of one of the following sets of conditions that is met:

- If the CURRENT PATH special register was assigned a value (by a SET PATH statement) in the scope of the invoking environment, the special register inherits the value from the invoking environment.
- If the connection is trusted, and both the role as object owner and qualifier options in effect, the special register is set to:"SYSIBM", "SYSFUN", "SYSPROC", "SYSIBMADM", "*role-name*" where *role-name* is the role that is associated with the user in the trusted context.
- Otherwise, the special register is set to: "SYSIBM", "SYSFUN", "SYSPROC", "SYSIBMADM", "*current-sqlid-value*".

The initial value of the CURRENT PATH special register in an SQL routine or trigger is determined from the first of one of the following sets of conditions that is met:

- In an SQL routine, the special register inherits the value from the invoking environment, if the special register was assigned a value (by a SET PATH statement) in the scope of the invoking environment.
- In a trigger, the special register inherits the value from the invoking environment, if the special register was assigned a value (by a SET PATH statement) in the scope of the invoking environment.
- In an SQL routine or trigger, the special register is set to the value specified for the SQL PATH routine or trigger option, if specified.
- In an SQL routine or trigger, the special register is set to the value specified for the SQL PATH routine or trigger option, if specified.
- If the connection is trusted, and both the role as object owner and qualifier options in effect, the special register is set to:"SYSIBM", "SYSFUN", "SYSPROC", "SYSIBMADM", "*role-name*" where *role-name* is the role that is associated with the user in the trusted context.
- Otherwise, the special register is set to: "SYSIBM", "SYSFUN", "SYSPROC", "SYSIBMADM", "*current-sqlid-value*".

If the value of the CURRENT SQLID special register changes after the initial value of PATH special register is established, the value of the PATH special register is unaffected when the CURRENT SQLID is updated. However, if a commit later occurs and a SET PATH statement has not been processed, the value of PATH special register is reinitialized taking into consideration the current value of the CURRENT SQLID special register.

You can change the value of the register by executing the statement SET PATH. For portability across the platforms, it is recommended that a SET PATH statement be issued at the beginning of an application.

Example: Set the special register so that schema SMITH is searched before the system schemas:

```
SET PATH = SMITH, SYSTEM PATH;
```

Related reference

[SET PATH statement](#)

The SET PATH statement assigns a value to the CURRENT PATH special register.

CURRENT PRECISION special register

CURRENT PRECISION specifies the rules to be used when both operands in a decimal operation have precisions of 15 or less.

The data type of the register is CHAR(5).

Valid values for the CURRENT PRECISION special register include 'DEC15', 'DEC31', or 'Dpp.s' where 'pp' is either 15 or 31 and 's' is a number in the range 1–9. DEC15 specifies the rules that do not allow a precision greater than 15 digits, and DEC31 specifies the rules that allow a precision of up to 31 digits. The rules for DEC31 are always used if either operand has a precision greater than 15. If the form 'Dpp.s' is used, 'pp' represents the precision that will be used as the rules where DEC15 and DEC31 rules are used, and 's' represents the minimum divide scale to use for division operations. The separator used in the form 'Dpp.s' can be either the '.' or the ',' character, regardless of the setting of the default decimal point.

The initial value of CURRENT PRECISION is determined by the value of field DECIMAL ARITHMETIC on installation panel DSNTIP4. The default for the initial value is DEC15 unless your installation has changed it to be DEC31 by modifying the value in that field. The initial value of CURRENT PRECISION in a user-defined function or stored procedure is inherited according to the rules in [Table 47 on page 215](#).

You can change the value of the register by executing the statement SET CURRENT PRECISION.

CURRENT PRECISION only affects dynamic SQL. When an SQL statement is dynamically prepared and the value of CURRENT PRECISION is DEC15 or D15.s, where 's' is a number in the range 1–9, DEC15 rules will apply. When an SQL statement is dynamically prepared and the value of CURRENT PRECISION is DEC31 or D31.s, where 's' is a number in the range 1–9, DEC31 rules will apply. Preparation of a statement with DEC31 instead of DEC15 is more likely to result in an error, especially for division operations. Specification of CURRENT PRECISION in the form 'Dpp.s' where 'pp' is either 15 or 31 and 's' represents the minimum divide scale, will in some cases make division errors less likely when 'pp' is set to 31. For more information, see [“Arithmetic with two decimal operands” on page 251](#).

Example 1: Set CURRENT PRECISION so that subsequent statements that are prepared use DEC31 rules for decimal arithmetic:

```
SET CURRENT PRECISION = 'DEC31';
```

Example 2: Set CURRENT PRECISION so that subsequent statements that are prepared use DEC31 rules for decimal arithmetic with a minimum divide scale of 3:

```
SET CURRENT PRECISION = 'D31.3';
```

Related reference

[SET CURRENT PRECISION statement](#)

The SET CURRENT PRECISION statement assigns a value to the CURRENT PRECISION special register.

CURRENT QUERY ACCELERATION special register

The CURRENT QUERY ACCELERATION special register specifies a value that identifies when Db2 sends dynamic SQL queries to an accelerator server and what Db2 does if the accelerator server fails. The special register does not apply to static SQL queries.

The data type is VARCHAR(255).

Valid values are:

NONE

Specifies that no queries are sent to an accelerator server.

ENABLE

Specifies that queries are accelerated only if Db2 determines that it is advantageous to do so. If an accelerator failure occurs while a query is running or if the accelerator returns an error, Db2 returns a negative SQLCODE to the application.

ENABLE WITH FAILBACK

Specifies that queries are accelerated only if Db2 determines that it is advantageous to do so. If the accelerator returns an error during the PREPARE or first OPEN for the query, Db2 executes the query without the accelerator. If the accelerator returns an error during a FETCH or a subsequent OPEN, Db2 returns the error to the user and does not execute the query.

Restriction: [FL 504](#) If the query contains a passthrough-only expression, Db2 returns an error and does not accelerate the query, even if a matching user-defined function exists. For more information about passthrough-only expressions, see [Accelerating queries with passthrough-only expressions](#).

ELIGIBLE

Specifies that queries are accelerated if they are eligible for acceleration. Db2 does not use cost information to determine whether to accelerate the queries. Queries that are not eligible for acceleration are executed by Db2. If an accelerator failure occurs while a query is running or if the accelerator returns an error, Db2 returns a negative SQLCODE to the application.

ALL

Specifies that queries are accelerated if they are eligible for acceleration. Db2 does not use cost information to determine whether to accelerate the queries. Queries that are not eligible for acceleration are not executed by Db2, and an SQL error is returned. If an accelerator failure occurs while a query is running or if the accelerator returns an error, Db2 returns a negative SQLCODE to the application.

The initial value of CURRENT QUERY ACCELERATION is determined by one of the following settings:

- The value of Db2 subsystem parameter QUERY_ACCELERATION. The default for the initial value of this subsystem parameter is NONE unless your installation has changed the value.
- If specified for the bind of a package, the QUERYACCELERATION bind option. This behavior enables the QUERYACCELERATION bind option to be used to specify the acceleration behavior for dynamic SQL queries and not only static SQL queries. This bind option does not have a default value.

The initial value of CURRENT QUERY ACCELERATION in a user-defined function or stored procedure is inherited according to the rules in [“Special registers in a user-defined function or a stored procedure”](#) on page 215.

You can change the value of the register by executing the SET CURRENT QUERY ACCELERATION statement.

The precedence order (lowest to highest) for setting the value of the special register is as follows:

- The QUERY_ACCELERATION subsystem parameter
- The QUERYACCELERATION bind option, if specified
- An explicit SET CURRENT QUERY ACCELERATION statement

Example: The following statement sets the CURRENT QUERY ACCELERATION special register so that no query acceleration occurs.

```
SET CURRENT QUERY ACCELERATION NONE;
```

Related concepts

[How Db2 determines whether to accelerate eligible queries \(Db2 Performance\)](#)

Related tasks

[Enabling acceleration of SQL queries \(Db2 Performance\)](#)

Related reference

[SET CURRENT QUERY ACCELERATION statement](#)

The SET CURRENT QUERY ACCELERATION statement changes the value of the CURRENT QUERY ACCELERATION special register.

CURRENT QUERY ACCELERATION WAITFORDATA special register

The CURRENT QUERY ACCELERATION WAITFORDATA special register specifies the maximum amount of time, if any, that the accelerator delays a dynamic SQL query while the accelerator waits for the replication of committed Db2 data changes that occurred prior to Db2 running the query. This special register does not apply to static SQL queries.

The data type is a DECIMAL(5,1) in the form of *nnnn.m*.

Valid values are a numeric constant in the range of 0.0–3600.0 seconds. For example, a value of 20.0 represents 20.0 seconds (or 20000 milliseconds), and a value of 30.5 represents 30.5 seconds (or 30500 milliseconds). The maximum value of 3600.0 means that the query is delayed for 60 minutes.

The default value is 0.0, which means that the query is not delayed and is run immediately on the accelerator. Other WAITFORDATA behavior is not applied to the query.

The wait time value can also be specified as an INTEGER numeric constant value ranging from 0 - 3600 seconds, which Db2 will convert to a DECIMAL (5,1) value.

You can change the value of the special register by executing the SET CURRENT QUERY ACCELERATION WAITFORDATA statement.

The initial value of CURRENT QUERY ACCELERATION WAITFORDATA is determined by one of the following settings:

- The value of Db2 QUERY_ACCEL_WAITFORDATA subsystem parameter. The default for the initial value of this subsystem parameter is 0.0 unless your installation has changed the value.
- If specified for the bind of a package, the ACCELERATIONWAITFORDATA bind option. This behavior enables the ACCELERATIONWAITFORDATA bind option to be used to specify the acceleration behavior for both dynamic SQL queries and static SQL queries. This bind option does not have a default value.

The initial value of CURRENT QUERY ACCELERATION WAITFORDATA in a user-defined function or stored procedure is inherited according to the rules in [“Special registers in a user-defined function or a stored procedure”](#) on page 215.

You can change the value of the register by executing the SET CURRENT QUERY ACCELERATION WAITFORDATA statement.

The precedence order (lowest to highest) for setting the value of the special register is as follows:

- The QUERY_ACCEL_WAITFORDATA subsystem parameter
- The ACCELERATIONWAITFORDATA bind option, if specified
- An explicit SET CURRENT QUERY ACCELERATION WAITFORDATA statement

For more information about the restrictions, requirements, and behaviors associated with CURRENT QUERY ACCELERATION WAITFORDATA, see [“SET CURRENT QUERY ACCELERATION WAITFORDATA statement”](#) on page 2150.

Example: The following statement sets the CURRENT QUERY ACCELERATION WAITFORDATA special register so that the accelerator delays queries for 180 seconds (three minutes) while it waits for committed Db2 data changes to be replicated to the accelerator.

```
SET CURRENT QUERY ACCELERATION WAITFORDATA 180;
```

Related reference

[SET CURRENT QUERY ACCELERATION WAITFORDATA statement](#)

The SET CURRENT QUERY ACCELERATION WAITFORDATA statement assigns a value to the CURRENT QUERY ACCELERATION WAITFORDATA special register.

[WAIT FOR DATA field \(QUERY_ACCEL_WAITFORDATA subsystem parameter\) \(Db2 Installation and Migration\)](#)

[CURRENT QUERY ACCELERATION special register](#)

The CURRENT QUERY ACCELERATION special register specifies a value that identifies when Db2 sends dynamic SQL queries to an accelerator server and what Db2 does if the accelerator server fails. The special register does not apply to static SQL queries.

CURRENT REFRESH AGE special register

CURRENT REFRESH AGE specifies a timestamp duration value. This duration is the maximum duration since a REFRESH TABLE statement has been processed on a system-maintained REFRESH DEFERRED materialized query table such that the materialized query table can be used to optimize the processing of a query. This special register affects dynamic statement cache matching.

The data type of the register is DECIMAL(20,6). For a description of durations, see [“Datetime operands and durations” on page 257](#).

If CURRENT REFRESH AGE has a value of 99999999999999 (ANY), REFRESH DEFERRED materialized query tables are considered to optimize the processing of a dynamic SQL query. This value represents 9999 years, 99 months, 99 days, 99 hours, and 99 seconds.

The initial value of CURRENT REFRESH AGE is determined by the value of field CURRENT REFRESH AGE on installation panel DSNTIP81. The default for the initial value of that field is 0 unless your installation has changed it to ANY by modifying the value of that field. The initial value of CURRENT REFRESH AGE in a user-defined function or stored procedure is inherited according to the rules in [Table 47 on page 215](#).

You can change the value of the register by executing the SET CURRENT REFRESH AGE statement.

Example : The following example retrieves the current value of the CURRENT REFRESH AGE special register into the host variable, CURMAXAGE:

```
EXEC SQL VALUES (CURRENT REFRESH AGE) INTO :CURMAXAGE;
```

The value would be '99999999999999.000000'.

Related reference

[SET CURRENT REFRESH AGE statement](#)

The SET CURRENT REFRESH AGE statement changes the value of the CURRENT REFRESH AGE special register.

CURRENT ROUTINE VERSION special register

CURRENT ROUTINE VERSION specifies the version identifier that is to be used when invoking a native SQL procedure. CURRENT ROUTINE VERSION is used for CALL statements that use a host variable to specify the procedure name.

The data type of CURRENT ROUTINE VERSION is VARCHAR(64).

The initial value of CURRENT ROUTINE VERSION in a user-defined function or stored procedure is inherited according to the rules in [Table 47 on page 215](#). In other contexts the initial value of CURRENT ROUTINE VERSION is an empty string. An empty string indicates that a version identifier is not in effect

for the SQL routine. When an SQL routine that does not have a version identifier in effect is invoked, the currently active version (as indicated in the catalog) of that routine is used.

You can change the value of the CURRENT ROUTINE VERSION by executing the statement SET CURRENT ROUTINE VERSION.

Setting the CURRENT ROUTINE VERSION special register to a version identifier might affect native SQL procedures that are invoked until the value of CURRENT ROUTINE VERSION is changed. If a version of an SQL procedure has a version identifier that matches the version identifier in the special register, that version of the SQL procedure is used when the SQL procedure is invoked. If an SQL procedure does not have a version identifier that matches the version identifier in the special register, the currently active version of the SQL procedure (as defined in the catalog) is used when the SQL procedure is invoked.

Example: Set the host variable `ROUTINE_VER` to the value of the CURRENT ROUTINE VERSION special register:

```
VALUES CURRENT ROUTINE VERSION INTO :ROUTINE_VER;
```

Related reference

[SET CURRENT ROUTINE VERSION statement](#)

The SET CURRENT ROUTINE VERSION statement assigns a value to the CURRENT ROUTINE VERSION special register. The special register sets the override value for the version identifier of native SQL procedures when they are invoked.

CURRENT RULES special register

CURRENT RULES specifies whether certain SQL statements are executed in accordance with Db2 rules or the rules of the SQL standard.

The data type of the register is CHAR(3), and the only valid values are 'DB2' and 'STD'.

CURRENT RULES is a register at the database server. If the server is not the local Db2, the initial value of the register is 'DB2'. Otherwise, the initial value is the same as the value of the SQLRULES bind option. The initial value of CURRENT RULES in a user-defined function or stored procedure is inherited according to the rules in [“Special registers in a user-defined function or a stored procedure”](#) on page 215.

You can change the value of the register by executing the statement SET CURRENT RULES.

CURRENT RULES affects the statements listed in the following table. The table summarizes when the statements are affected and shows where to find detailed information. CURRENT RULES also affects whether Db2 issues an existence error (SQLCODE -204) or an authorization error (SQLCODE -551) when an object does not exist. For CURRENT RULES 'STD', Db2 issues an authorization error (SQLCODE -551) when an object does not exist instead of the existence error (SQLCODE -204).

Table 46. Summary of statements affected by CURRENT RULES

Statement	What is affected	Details in topic
ALTER TABLE	<p>The following behaviors:</p> <ul style="list-style-type: none"> Enforcement of check constraints added. Default value of the delete rule for referential constraints. Whether Db2 creates LOB table spaces, auxiliary tables, and indexes on auxiliary tables for added LOB columns. See LOB table space implicit creation (Db2 Administration Guide). Whether Db2 creates an index for an added ROWID column that is defined with GENERATED BY DEFAULT. 	<p>“ALTER TABLE statement” on page 1232</p>

Table 46. Summary of statements affected by CURRENT RULES (continued)

Statement	What is affected	Details in topic
CREATE TABLE	The following behaviors: <ul style="list-style-type: none"> • Default value of the delete rule for referential constraints. • Whether Db2 creates LOB table spaces, auxiliary tables, and indexes on auxiliary tables for LOB columns if the table is explicitly created. See LOB table space implicit creation (Db2 Administration Guide). • Whether Db2 creates an index for a ROWID column that is defined with GENERATED BY DEFAULT if the table is explicitly created. 	“CREATE TABLE statement” on page 1650
GRANT	Granting privileges to yourself.	“GRANT statement” on page 1963
REVOKE	Revoking privileges from authorization IDs	“REVOKE statement” on page 2070

Set CURRENT RULES so that a later ALTER TABLE statement is executed in accordance with the rules of the SQL standard:

```
SET CURRENT RULES = 'STD';
```

Related reference

[SET CURRENT RULES statement](#)

The SET CURRENT RULES statement assigns a value to the CURRENT RULES special register.

[SQLRULES bind option \(Db2 Commands\)](#)

CURRENT SCHEMA special register

The CURRENT SCHEMA special register specifies the schema name used to qualify unqualified database object references in dynamically prepared SQL statements.

The data type is VARCHAR(128).

For information on when the CURRENT SCHEMA is used to resolve unqualified names in dynamic SQL statements and the effect of its value, see [“Unqualified object name resolution” on page 86](#).

The CURRENT SCHEMA special register contains a value that is a single identifier without delimiters.

The initial value of the special register is the value of CURRENT SQLID at the time the connection is established. If the connection is established as a trusted connection with a role as the object owner and qualifier, the initial value of the special register is the value of the role name that is associated with the user in the trusted context. The initial value of the special register in a user-defined function or procedure is inherited according to the rules in [Table 47 on page 215](#).

The value of the special register can be changed by executing the SET SCHEMA statement. The value of CURRENT SCHEMA is the same as the value of CURRENT SQLID unless a SET SCHEMA statement has been issued specifying a different value. After a SET SCHEMA statement has been issued in an application, the values of CURRENT SCHEMA and CURRENT SQLID are separate. Therefore, if the value of CURRENT SCHEMA needs to be changed, a SET SCHEMA statement must be issued.

Specifying CURRENT_SCHEMA is equivalent to specifying CURRENT SCHEMA.

Example: Set the schema for object qualification to 'D123'.

```
SET SCHEMA = 'D123'
```

CURRENT SERVER special register

CURRENT SERVER specifies the location name of the current server.

The data type is CHAR(16). If necessary, the location name is padded on the right with blanks so that its length is 16 bytes.

The initial value of CURRENT SERVER depends on the CURRENTSERVER bind option. If CURRENTSERVER *X* is specified on the bind subcommand, the initial value is *X*. If the option is not specified, the initial value is the location name of the local Db2. The initial value of CURRENT SERVER in a user-defined function or stored procedure is inherited according to the rules in [Table 47 on page 215](#). The value of CURRENT SERVER is changed by the successful execution of a CONNECT statement.

The value of CURRENT SERVER is a string of blanks when either of the following conditions apply:

- The application process is in the unconnected state
- The application process is connected to a local Db2 subsystem that does not have a location name.

Example

Set the host variable CS to the location name of the current server.

```
EXEC SQL SET :CS = CURRENT SERVER;
```

CURRENT SQLID special register

CURRENT SQLID specifies the SQL authorization ID of the process.

The data type is VARCHAR(128).

The SQL authorization ID is:

- The authorization ID used for authorization checking on dynamically prepared CREATE, GRANT, and REVOKE SQL statements.
- The owner of a table space, database, storage group, or synonym created by a dynamically issued CREATE statement.

The initial value of CURRENT SQLID can be provided by the connection or sign-on exit routine. If not, the initial value is the primary authorization ID of the process. The value remains in effect until one of the following events occurs:

- The SQL authorization ID is changed by the execution of a SET CURRENT SQLID statement.
- A SIGNON or re-SIGNON request is received from a CICS transaction subtask or an IMS independent region.
- The Db2 connection is ended.
- When running in a trusted connection, the user is switched.

The initial value of CURRENT SQLID in a user-defined function or stored procedure is inherited according to the rules in [Table 47 on page 215](#).

CURRENT SQLID can only be referred to in an SQL statement that is executed by the current server.

CURRENT SQLID cannot be a role.

Examples for SET CURRENT SQLID

Example 1

Set the CURRENT SQLID to the primary authorization ID.

```
SET CURRENT SQLID = SESSION_USER;
```

Example 2

Set the SQL authorization ID to 'GROUP34' (one of the authorization IDs of the process).

```
SET CURRENT SQLID = 'GROUP34';
```

CURRENT TEMPORAL BUSINESS_TIME special register

The CURRENT TEMPORAL BUSINESS_TIME special register specifies a TIMESTAMP(12) value that is used in the default BUSINESS_TIME period specification for references to application-period temporal tables.

When a query references an application-period temporal table and the value of the CURRENT TEMPORAL BUSINESS_TIME special register is not the null value, the query is affected as follows:

- If the columns of a BUSINESS_TIME period are defined as TIMESTAMP, the following period specification is implicit:

```
FOR BUSINESS_TIME AS OF CURRENT TEMPORAL BUSINESS_TIME
```

- If the columns of a BUSINESS_TIME period are defined as DATE, the following period specification is implicit: :

```
FOR BUSINESS_TIME AS OF CAST(CURRENT TEMPORAL BUSINESS_TIME AS DATE)
```

The initial value of the special register depends on the context as follows:

- If the special register is in a trigger, the initial value is inherited from the invoking application.
- If the special register is in a user-defined function or procedure that is defined with the INHERIT SPECIAL REGISTERS option, the initial value is inherited from the invoking application.
- If the special register is in a user-defined function or procedure that is defined with the DEFAULT SPECIAL REGISTERS option, the initial value is the null value.
- In other contexts, the initial value of the special register is the null value.

You can change the value of the special register by using the SET CURRENT TEMPORAL BUSINESS_TIME statement. If you change the value within a routine, that new value is not passed back to the invoking application.

Examples

Example of a query that references an application-period temporal table

Assume the following conditions:

- ATT is an application-period temporal table and POLICY_ID is a column in ATT.
- The value of the BUSTIMESENSITIVE bind option is YES.
- The value of CURRENT TEMPORAL BUSINESS_TIME is not null.

Then, suppose that you issue the following query:

```
SELECT * FROM ATT  
WHERE POLICY_ID = 123;
```

Db2 generates an implicit BUSINESS_TIME period specification for the query as follows:

```
SELECT * FROM ATT  
FOR BUSINESS_TIME AS OF CURRENT TEMPORAL BUSINESS_TIME  
WHERE POLICY_ID = 123;
```

Example of a procedure that uses CURRENT TEMPORAL BUSINESS_TIME

Suppose that procedure MYPROC is defined as follows:

```
CREATE PROCEDURE MYPROC(OUT VAR1 VARCHAR(40), OUT VAR2 VARCHAR(40))
BEGIN
  SELECT CURRENT TEMPORAL BUSINESS_TIME INTO VAR1
  FROM SYSIBM.SYSDUMMY1;

  SET CURRENT TEMPORAL BUSINESS_TIME = TIMESTAMP('2011-01-01') + 5 DAYS ;

  SELECT CURRENT TEMPORAL BUSINESS_TIME INTO VAR2
  FROM SYSIBM.SYSDUMMY1;
END!
```

Suppose that the application defines string variables VAR1, VAR2, and VAR3 and contains the following SQL statements:

```
SET CURRENT TEMPORAL BUSINESS_TIME = TIMESTAMP('2008-01-01') + 5 DAYS ;

CALL MYPROC(VAR1, VAR2);

SELECT CURRENT TEMPORAL BUSINESS_TIME INTO VAR3
FROM SYSIBM.SYSDUMMY1;
```

After the execution of the SQL statements, the variables have the following values:

- VAR1 has value '2008-01-06-00.00.00.000000000000', which is the CURRENT TEMPORAL BUSINESS_TIME value that is set before the CALL statement invoked the procedure.
- VAR2 has value '2011-01-06-00.00.00.000000000000', which is the CURRENT TEMPORAL BUSINESS_TIME value that is set during the CALL statement.
- VAR3 has value '2008-01-06-00.00.00.000000000000', which is the CURRENT TEMPORAL BUSINESS_TIME value that is set before the CALL statement. The changes of the register value inside the procedure have no affect on the invoking application.

Example of a query that references CURRENT TEMPORAL BUSINESS_TIME

Assume that IN_TRAY is an application-period temporal table that contains users and subject lines for notes in the inbox. The following query returns the user ID and subject line for notes in the IN_TRAY table that were sent on the date that the CURRENT TEMPORAL BUSINESS_TIME special register is set to.

```
SELECT SOURCE, SUBJECT
FROM IN_TRAY
WHERE DATE (CURRENT TEMPORAL BUSINESS_TIME) = DATE (RECEIVED)
```

Related tasks

[Querying temporal tables \(Db2 Administration Guide\)](#)

Related reference

[table-reference](#)

A *table-reference* specifies a result table as either a table or view, or an intermediate table.

[BIND and REBIND options for packages, plans, and services \(Db2 Commands\)](#)

[SET CURRENT TEMPORAL BUSINESS_TIME statement](#)

The SET CURRENT TEMPORAL BUSINESS_TIME statement changes the value of the CURRENT TEMPORAL BUSINESS_TIME special register.

[Special registers in a user-defined function or a stored procedure](#)

You can use all special registers in a user-defined function or a stored procedure. However, you can modify only some of those special registers.

CURRENT TEMPORAL SYSTEM_TIME special register

The CURRENT TEMPORAL SYSTEM_TIME special register specifies a TIMESTAMP(12) value that is used in the default SYSTEM_TIME period specification for references to system-period temporal tables.

When a query references a system-period temporal table and the value of the CURRENT TEMPORAL SYSTEM_TIME special register is not the null value, the following period specification is implicit:

```
FOR SYSTEM_TIME AS OF CURRENT TEMPORAL SYSTEM_TIME
```

The initial value of the special register depends on the context as follows:

- If the special register is in a trigger, the initial value is inherited from the invoking application.
- If the special register is in a user-defined function or procedure that is defined with the INHERIT SPECIAL REGISTERS option, the initial value is inherited from the invoking application.
- If the special register is in a user-defined function or procedure that is defined with the DEFAULT SPECIAL REGISTERS option, the initial value is the null value.
- In other contexts, the initial value of the special register is the null value.

You can change the value of the special register by using the SET CURRENT TEMPORAL SYSTEM_TIME statement. If you change the value within a routine, that new value is not passed back to the invoking application.

When the value of the CURRENT TEMPORAL SYSTEM_TIME special register is not null and the SYSTIMESENSITIVE bind option is set to YES, you cannot explicitly specify FOR SYSTEM_TIME in a *select-statement*.

Examples

Example of a query that references a system-period temporal table

Assume the following conditions:

- STT is a system-period temporal table, and POLICY_ID is a column of STT.
- The value of the SYSTIMESENSITIVE bind option is YES.
- The value of CURRENT TEMPORAL SYSTEM_TIME is not null.

Then, suppose that you issue the following query:

```
SELECT * FROM STT
WHERE POLICY_ID = 123;
```

Db2 generates an implicit SYSTEM_TIME period specification for the query as follows:

```
SELECT * FROM STT
FOR SYSTEM_TIME AS OF CURRENT TEMPORAL SYSTEM_TIME
WHERE POLICY_ID = 123;
```

Example of a procedure that uses CURRENT TEMPORAL SYSTEM_TIME

Suppose that procedure MYPROC is defined as follows:

```
CREATE PROCEDURE MYPROC(OUT VAR1 VARCHAR(40), OUT VAR2 VARCHAR(40))
BEGIN
  SELECT CURRENT TEMPORAL SYSTEM_TIME INTO VAR1
  FROM SYSIBM.SYSDUMMY1;

  SET CURRENT TEMPORAL SYSTEM_TIME = TIMESTAMP('2011-01-01') + 5 DAYS ;

  SELECT CURRENT TEMPORAL SYSTEM_TIME INTO VAR2
  FROM SYSIBM.SYSDUMMY1;
END!
```

Suppose that the application defines string variables VAR1, VAR2, and VAR3 and contains the following SQL statements:

```
SET CURRENT TEMPORAL SYSTEM_TIME = TIMESTAMP('2008-01-01') + 5 DAYS ;  
CALL MYPROC(VAR1, VAR2);  
  
SELECT CURRENT TEMPORAL SYSTEM_TIME INTO VAR3  
FROM SYSIBM.SYSDUMMY1
```

After the execution of the SQL statements, the variables have the following values:

- VAR1 has value '2008-01-06-00.00.00.000000000000', which is the CURRENT TEMPORAL SYSTEM_TIME value that is set before the CALL statement invoked the procedure.
- VAR2 has value '2011-01-06-00.00.00.000000000000', which is the CURRENT TEMPORAL SYSTEM_TIME value that is set during the CALL statement.
- VAR3 has value '2008-01-06-00.00.00.000000000000', which is the CURRENT TEMPORAL SYSTEM_TIME value that is set before the CALL statement. The changes of the register value inside the procedure have no effect on the invoking application.

Example of a query that references a system-period temporal table

Assume that IN_TRAY is a system-period temporal table that contains users and subject lines for notes in the inbox. The following query returns the user IDs and subject lines based on the state of the messages in IN_TRAY as of the date that is specified by the CURRENT TEMPORAL SYSTEM_TIME special register.

```
SELECT SOURCE, SUBJECT  
FROM IN_TRAY
```

If the special register is set to a non-null value, the previous statement is equivalent to the following statement:

```
SELECT SOURCE, SUBJECT  
FROM IN_TRAY  
FOR SYSTEM_TIME AS OF CURRENT TEMPORAL SYSTEM_TIME
```

Related tasks

[Querying temporal tables \(Db2 Administration Guide\)](#)

Related reference

[table-reference](#)

A *table-reference* specifies a result table as either a table or view, or an intermediate table.

[BIND and REBIND options for packages, plans, and services \(Db2 Commands\)](#)

[SET CURRENT TEMPORAL SYSTEM_TIME statement](#)

The SET CURRENT TEMPORAL SYSTEM_TIME statement changes the value of the CURRENT TEMPORAL SYSTEM_TIME special register.

[Special registers in a user-defined function or a stored procedure](#)

You can use all special registers in a user-defined function or a stored procedure. However, you can modify only some of those special registers.

CURRENT TIME special register

The CURRENT TIME special register specifies a time that is based on a reading of the time-of-day clock when the SQL statement is executed at the current server.

If this special register is used more than one time within a single SQL statement, or used with CURRENT DATE or CURRENT TIMESTAMP within a single statement, all values are based on a single clock reading.¹⁰

The value of CURRENT TIME in a user-defined function or stored procedure is inherited according to the rules in [Table 47 on page 215](#). For other applications, the time is derived by the Db2 that executes

¹⁰ Except for the case of a non-atomic multiple row INSERT or MERGE statement.

the SQL statement that refers to the special register. For a description of how the date is derived, see Datetime special registers.

Specifying CURRENT_TIME is equivalent to specifying CURRENT TIME.

Example

Display information about all project activities and include the current date and time in each row of the result.

```
SELECT DSN8C10.PROJACT.*, CURRENT DATE, CURRENT TIME
FROM DSN8C10.PROJACT;
```

CURRENT TIMESTAMP special register

The CURRENT TIMESTAMP special register specifies a timestamp that is based on a reading of the time-of-day clock when the SQL statement is executed at the current server.

If this special register is used more than one time within a single SQL statement, or used with CURRENT DATE or CURRENT TIME within a single statement, all values are based on a single clock reading.¹¹

The value of CURRENT TIMESTAMP in a user-defined function or stored procedure is inherited according to the rules in [Table 47 on page 215](#).

Specifying CURRENT_TIMESTAMP is equivalent to specifying CURRENT TIMESTAMP.

If you want a timestamp with a specified precision, the special register can be referenced as CURRENT TIMESTAMP(*integer*), where *integer* can range 0–12. The default precision is 6. SYSDATE can also be specified as a synonym for CURRENT TIMESTAMP(0).

If you want a timestamp with a time zone, the special register can be referenced as CURRENT TIMESTAMP (*integer*) WITH TIME ZONE, or CURRENT TIMESTAMP WITH TIME ZONE. SYSTIMESTAMP can be specified as an alternative to CURRENT TIMESTAMP(12) WITH TIME ZONE. The time zone is determined from the CURRENT TIME ZONE special register.

Note: If the CURRENT TIMESTAMP special register is referenced in a timestamp with time zone context (for example, when compared with a timestamp with time zone column) the implicit time zone for the CURRENT TIMESTAMP special register will be based on the implicit time zone system parameter, which could be a different value from the CURRENT TIME ZONE special register. To avoid misinterpretation of the time zone in this case, CURRENT TIMESTAMP WITH TIME ZONE should be used.

Examples

Example 1

Display information about the full image copies that were taken in the last week.

```
SELECT * FROM SYSIBM.SYSCOPY
WHERE TIMESTAMP > CURRENT TIMESTAMP - 7 DAYS;
```

Example 2

Insert a row into the IN_TRAY table. The value of the RECEIVED column should be a timestamp that indicates when the row was inserted. The values for the other three columns come from the host variables SRC (CHAR(8)), SUB (CHAR(64)), and TXT (VARCHAR(200)).

```
INSERT INTO IN_TRAY
VALUES (CURRENT TIMESTAMP, :SRC, :SUB, :TXT)
```

Example 3

Retrieve the value of the CURRENT TIMESTAMP special register with a precision of 8 and include the time zone:

¹¹ Except for the case of a non-atomic multiple row INSERT or MERGE statement.

```
SELECT CURRENT_TIMESTAMP(8) WITH TIME ZONE
FROM SYSIBM.SYSDUMMY1;
```

CURRENT TIME ZONE special register

The CURRENT TIME ZONE special register specifies a value that contains the difference between UTC and local time as defined by the current server, if the SESSION TIME ZONE special register has not been set.

The local time difference for the current server is set by z/OS, in the CLOCKxx PARMLIB member.

The data type is DECIMAL(6,0).

The difference between UTC and local time at the current server is represented by a time duration. A time duration is a decimal number in which the first two digits are the number of hours, the next two digits are the number of minutes, and the last two digits are the number of seconds. The number of hours is adjusted, if necessary, to fit in the range between -24 and 24 exclusive.

Subtracting CURRENT TIME ZONE from a local time converts that local time to UTC.

CURRENT TIMEZONE can be specified as an alternative to CURRENT TIME ZONE.

Example

The following statement selects all rows of the IN_TRAY table. Assume that the RECEIVED column is defined as TIMESTAMP WITHOUT TIME ZONE. Adjust the timestamp value in the RECEIVED column to UTC by subtracting the value of the CURRENT TIME ZONE special register.

```
SELECT RECEIVED - CURRENT TIME ZONE, SOURCE, SUBJECT, NOTE_TEXT
FROM IN_TRAY;
```

Related information

[CLOCKxx \(time of day parameters\) \(MVS Initialization and Tuning Reference\)](#)

ENCRYPTION PASSWORD special register

The ENCRYPTION PASSWORD special register specifies the encryption password and the password hint (if one exists) that are used by the ENCRYPT_TDES, DECRYPT_BIT, DECRYPT_CHAR, and DECRYPT_DB built-in functions.

DECRYPT_BIT, DECRYPT_CHAR, and DECRYPT_DB

This special register can only be set, by using the SET ENCRYPTION PASSWORD statement, and cannot be referenced directly. The ENCRYPTION PASSWORD special register contains the value of the password that is used by the ENCRYPT_TDES and DECRYPT_BIT, DECRYPT_CHAR, and DECRYPT_DB built-in functions to encrypt and decrypt data when a password is not explicitly specified as a function argument. The ENCRYPTION PASSWORD special register can also contain a password hint which is associated with the values that are encrypted using the encryption password. The password hint is a character string that is used to help in remembering the password. The GETHINT function is used to return the password hint for an encrypted value.

The initial value of the ENCRYPTION PASSWORD special register is the empty string ('').

The initial value of the ENCRYPTION PASSWORD special register in a user-defined function or procedure is inherited from the invoking application. In other contexts, the initial value of the special register is the empty string.

The password is not related to Db2 authentication and is used only for data encryption.

Related reference

[SET ENCRYPTION PASSWORD statement](#)

The SET ENCRYPTION PASSWORD statement sets the value of the encryption password and, optionally, the password hint. The ENCRYPT_TDES, DECRYPT_BIT, DECRYPT_CHAR, and DECRYPT_DB built-in functions use this password and password hint for data encryption unless the functions are invoked

with an explicitly specified password and hint. The password is not tied to Db2 authentication and is used only for data encryption.

SESSION TIME ZONE special register

The SESSION TIME ZONE special register specifies a value that identifies the time zone of the application process.

The data type is VARCHAR(128).

The time zone value is in the format of $\pm th:tm$. *th* represents the time zone hour offset. *tm* represents the time zone minute offset. Valid values for *th* are between -12 and +14. Valid values for *tm* are between 0 and 59. SESSION TIMEZONE can be specified as an alternative to SESSION TIME ZONE.

The initial value of the special register in a user-defined function or stored procedure is inherited according to the rules in [“Special registers in a user-defined function or a stored procedure”](#) on page 215. In other contexts the initial value of the special register represents the same time zone as the CURRENT TIME ZONE special register.

The value of the special register can be changed by executing the SET SESSION TIME ZONE statement. After a SET SESSION TIME ZONE statement has been processed, the values of the SESSION TIME ZONE and CURRENT TIME ZONE special register might not reflect the same value.

Example

The following statement set the session time zone to '-8:00'.

```
SET SESSION TIME ZONE = '-8:00';
```

Related reference

[SET SESSION TIME ZONE statement](#)

The SET SESSION TIME ZONE statement assigns a value to the SESSION TIME ZONE special register.

SESSION_USER special register

SESSION_USER specifies the primary authorization ID of the process.

The data type is VARCHAR(128).

If SESSION_USER is referred to in an SQL statement that is executed at a remote Db2 and the primary authorization ID has been translated to a different authorization ID, SESSION_USER specifies the translated authorization ID. The value of SESSION_USER in a user-defined function or stored procedure is determined according to the rules in [Table 47 on page 215](#).

USER can be specified as a synonym for SESSION_USER.

Example

Display information about tables, views, and aliases that are owned by the primary authorization ID of the process.

```
SELECT * FROM SYSIBM.SYSTABLES WHERE CREATOR = SESSION_USER;
```

Related concepts

[Authorization ID translations](#)

When certain authorization IDs are sent to a remote DBMS, those authorization IDs might undergo translation before being used.

Related tasks

[Translating inbound IDs \(Managing Security\)](#)

USER special register

USER specifies the primary authorization ID of the process. The data type is VARCHAR(128). SESSION_USER is the preferred spelling.

If USER is referred to in an SQL statement that is executed at a remote Db2 and the primary authorization ID has been translated to a different authorization ID, USER specifies the translated authorization ID. The value of USER in a user-defined function or stored procedure is determined according to the rules in [Table 47 on page 215](#).

Example

Display information about tables, views, and aliases that are owned by the primary authorization ID of the process.

```
SELECT * FROM SYSIBM.SYSTABLES WHERE CREATOR = USER;
```

Related concepts

[Authorization ID translations](#)

When certain authorization IDs are sent to a remote DBMS, those authorization IDs might undergo translation before being used.

Related tasks

[Translating inbound IDs \(Managing Security\)](#)

Related reference

[SESSION_USER special register](#)

SESSION_USER specifies the primary authorization ID of the process.

Special registers in a user-defined function or a stored procedure

You can use all special registers in a user-defined function or a stored procedure. However, you can modify only some of those special registers.

After a user-defined function or a stored procedure completes, Db2 restores all special registers to the values they had before invocation.

The following table shows information that you need when you use special registers in a user-defined function or stored procedure.

Table 47. Characteristics of special registers in a user-defined function or a stored procedure

Special register	Initial value when INHERIT SPECIAL REGISTERS option is specified	Initial value when DEFAULT SPECIAL REGISTERS option is specified	Routine can use SET statement to modify?
CURRENT ACCELERATOR	Inherited from the invoking application ⁶ ; otherwise, no preferred accelerator is used and Db2 will determine the target accelerator	The ACCELERATOR bind option value if specified for the user-defined function or stored procedure package; otherwise, no preferred accelerator is used and Db2 will determine the target accelerator	Yes
CURRENT APPLICATION COMPATIBILITY	The value of bind option APPLCOMPAT for the user-defined function or stored procedure package	The value of bind option APPLCOMPAT for the user-defined function or stored procedure package	Yes

Table 47. Characteristics of special registers in a user-defined function or a stored procedure (continued)

Special register	Initial value when INHERIT SPECIAL REGISTERS option is specified	Initial value when DEFAULT SPECIAL REGISTERS option is specified	Routine can use SET statement to modify?
CURRENT APPLICATION ENCODING SCHEME	The value of bind option ENCODING for the user-defined function or stored procedure package	The value of bind option ENCODING for the user-defined function or stored procedure package	Yes
CURRENT CLIENT_ACCTNG	Inherited from the invoking application	Inherited from the invoking application	Not applicable ⁵
CURRENT CLIENT_APPLNAME	Inherited from the invoking application	Inherited from the invoking application	Not applicable ⁵
CURRENT CLIENT_USERID	Inherited from the invoking application	Inherited from the invoking application	Not applicable ⁵
CURRENT CLIENT_WRKSTNNAME	Inherited from the invoking application	Inherited from the invoking application	Not applicable ⁵
CURRENT DATE	New value for each SQL statement in the user-defined function or stored procedure package ¹	New value for each SQL statement in the user-defined function or stored procedure package ¹	Not applicable ⁵
CURRENT DEBUG MODE	Inherited from the invoking application	DISALLOW	Yes
CURRENT DECFLOAT ROUNDING MODE	Inherited from the invoking application	The value of bind option ROUNDING for the user-defined function or stored procedure package	Yes
CURRENT DEGREE	CURRENT DEGREE ²	The value of field CURRENT DEGREE on installation panel DSNTIP8	Yes
CURRENT EXPLAIN MODE	Inherited from the invoking application	NO	Yes
CURRENT GET_ACCEL_ARCHIVE	Inherited from the invoking application ⁶ ; otherwise, the subsystem parameter value will be used	The GETACCELARCHIVE bind option value if specified for the user-defined function or stored procedure package; otherwise, the subsystem parameter value will be used	Yes
CURRENT LOCALE LC_CTYPE	Inherited from the invoking application	The value of field CURRENT LC_CTYPE on installation panel DSNTIPF	Yes
CURRENT MAINTAINED TABLE TYPES FOR OPTIMIZATION	Inherited from the invoking application	System default value	Yes
CURRENT MEMBER	New value for each SET <i>host-variable</i> =CURRENT MEMBER statement	New value for each SET <i>host-variable</i> =CURRENT MEMBER statement	Not applicable ⁵

Table 47. Characteristics of special registers in a user-defined function or a stored procedure (continued)

Special register	Initial value when INHERIT SPECIAL REGISTERS option is specified	Initial value when DEFAULT SPECIAL REGISTERS option is specified	Routine can use SET statement to modify?
CURRENT OPTIMIZATION HINT	The value of bind option OPTHINT for the user-defined function or stored procedure package or inherited from the invoking application ⁶	The value of bind option OPTHINT for the user-defined function or stored procedure package	Yes
CURRENT PACKAGE PATH	An empty string if the routine was defined with a COLLID value; otherwise, inherited from the invoking application ⁴	An empty string, regardless of whether a COLLID value was specified for the routine ⁴	Yes
CURRENT PACKAGESET	Inherited from the invoking application ³	Inherited from the invoking application ³	Yes
CURRENT PATH	The value of bind option PATH for the user-defined function or stored procedure package or inherited from the invoking application ⁶	The value of bind option PATH for the user-defined function or stored procedure package	Yes
CURRENT PRECISION	Inherited from the invoking application	The value of field DECIMAL ARITHMETIC on installation panel DSNTIP4	Yes
CURRENT QUERY ACCELERATION	Inherited from the invoking application ⁶ ; otherwise, the subsystem parameter value will be used	The QUERYACCELERATION bind option value if specified for the user-defined function or stored procedure package; otherwise, the subsystem parameter value will be used	Yes
CURRENT QUERY ACCELERATION WAITFOR DATA	Inherited from the invoking application ⁶ ; otherwise, the subsystem parameter value will be used	The ACCELERATIONWAITFOR DATA A bind option value if specified for the user-defined function or stored procedure package; otherwise, the subsystem parameter value will be used	Yes
CURRENT REFRESH AGE	Inherited from the invoking application	System default value	Yes
CURRENT ROUTINE VERSION	Inherited from the invoking application	The empty string	Yes
CURRENT RULES	Inherited from the invoking application	The value of bind option SQLRULES for the plan that invokes a user-defined function or stored procedure	Yes
CURRENT SCHEMA	Inherited from the invoking application	The value of CURRENT SCHEMA when the routine is entered	Yes

Table 47. Characteristics of special registers in a user-defined function or a stored procedure (continued)

Special register	Initial value when INHERIT SPECIAL REGISTERS option is specified	Initial value when DEFAULT SPECIAL REGISTERS option is specified	Routine can use SET statement to modify?
CURRENT SERVER	Inherited from the invoking application	Inherited from the invoking application	Yes
CURRENT SQLID	The primary authorization ID of the application process or inherited from the invoking application ⁷	The primary authorization ID of the application process	Yes ⁸
CURRENT TEMPORAL BUSINESS_TIME	Inherited from the invoking application	NULL	Yes
CURRENT TEMPORAL SYSTEM_TIME	Inherited from the invoking application	NULL	Yes
CURRENT TIME	New value for each SQL statement in the user-defined function or stored procedure package ¹	New value for each SQL statement in the user-defined function or stored procedure package ¹	Not applicable ⁵
CURRENT TIMESTAMP	New value for each SQL statement in the user-defined function or stored procedure package ¹	New value for each SQL statement in the user-defined function or stored procedure package ¹	Not applicable ⁵
CURRENT TIMESTAMP WITH TIME ZONE	New value for each SQL statement in the user-defined function or stored procedure package ¹	New value for each SQL statement in the user-defined function or stored procedure package ¹	Not applicable ⁵
CURRENT TIME ZONE	Inherited from the invoking application	Inherited from the invoking application	Not applicable ⁵
ENCRYPTION PASSWORD	Inherited from the invoking application	Inherited from the invoking application	Yes
SESSION TIME ZONE	Inherited from the invoking application	The value of CURRENT TIME ZONE when the routine is entered	Yes
SESSION_USER or USER	Primary authorization ID of the application process	Primary authorization ID of the application process	Not applicable ⁵

Table 47. Characteristics of special registers in a user-defined function or a stored procedure (continued)

Special register	Initial value when INHERIT SPECIAL REGISTERS option is specified	Initial value when DEFAULT SPECIAL REGISTERS option is specified	Routine can use SET statement to modify?
------------------	--	--	--

Notes:

1. If the user-defined function or stored procedure is invoked within the scope of a trigger, Db2 uses the timestamp for the triggering SQL statement as the timestamp for all SQL statements in the package.
2. Db2 allows parallelism at only one level of a nested SQL statement. If you set the value of the CURRENT DEGREE special register to ANY, and parallelism is disabled, Db2 ignores the CURRENT DEGREE value.
3. If the routine definition includes a specification for COLLID, Db2 sets CURRENT PACKAGESET to the value of COLLID. If both CURRENT PACKAGE PATH and COLLID are specified, the CURRENT PACKAGE PATH value takes precedence and COLLID is ignored.
4. If the function definition includes a specification for PACKAGE PATH, Db2 sets CURRENT PACKAGE PATH to the value of PACKAGE PATH.
5. Not applicable because no SET statement exists for the special register.
6. If a program within the scope of the invoking program issues a SET statement for the special register before the user-defined function or stored procedure is invoked, the special register inherits the value from the SET statement. Otherwise, the special register contains the value that is set by the bind option for the user-defined function or stored procedure package.
7. If a program within the scope of the invoking program issues a SET CURRENT SQLID statement before the user-defined function or stored procedure is invoked, the special register inherits the value from the SET statement. Otherwise, CURRENT SQLID contains the authorization ID of the application process.
8. If the user-defined function or stored procedure package uses a value other than RUN for the DYNAMICRULES bind option, the SET CURRENT SQLID statement can be executed. However, it does not affect the authorization ID that is used for the dynamic SQL statements in the package. The DYNAMICRULES value determines the authorization ID that is used for dynamic SQL statements.

Related concepts

[Dynamic rules options for dynamic SQL statements \(Db2 Application programming and SQL\)](#)

Related reference

[BIND and REBIND options for packages, plans, and services \(Db2 Commands\)](#)

[Special registers](#)

A special register is a storage area that is defined for an application process by Db2 and is used to store information that can be referenced in SQL statements. A reference to a special register is a reference to a value provided by the current server. If the value is a string, its CCSID is a default CCSID of the current server.

Column names

The meaning of a column name depends on its context.

A column name can be used to:

- Declare the name of a column, as in a CREATE TABLE statement.
- Specify the name of a column, as in a CREATE FUNCTION statement to name a column of the result table of a table function.
- Identify a column, as in a CREATE INDEX statement.
- Specify values of the column, as in the following contexts:
 - In an *aggregate function*, a column name specifies all values of the column in the group or intermediate result table to which the function is applied. (Groups and intermediate result tables

are explained in [Chapter 6, “Queries,”](#) on page 1007.) For example, MAX(SALARY) applies the function MAX to all values of the column SALARY in a group.

- In a *GROUP BY* or *ORDER BY* clause, a column name specifies all values in the intermediate result table to which the clause is applied. For example, ORDER BY DEPT orders an intermediate result table by the values of the column DEPT.
- In an *expression*, a *search condition*, or a *scalar function*, a column name specifies a value for each row or group to which the construct is applied. For example, when the search condition CODE = 20 is applied to some row, the value specified by the column name CODE is the value of the column CODE in that row.
- Provide a column name for an expression to temporarily rename a column, as in the *correlation-clause* of a *table-reference* in a FROM clause or as in the AS clause in the *select-clause*.

Qualified column names

A qualifier for a column name can be a table name, a view name, an alias name, a synonym, or a correlation name. Whether a column name can be qualified depends, like its meaning, on its context.

- In some forms of the COMMENT and LABEL statements, a column name must be qualified. This is shown in the syntax diagrams.
- Where the column name specifies values of the column, a column name can be qualified at the user's option.
- In the column list of an INSERT statement, a column name can be qualified.
- In the *assignment-clause* of an UPDATE or a MERGE statement, a column name can be qualified.
- In all other contexts, a column name must not be qualified. This rule will be mentioned in the discussion of each statement to which it applies.

Where a qualifier is optional, it can serve two purposes. See [“Column name qualifiers to avoid ambiguity”](#) on page 221 for details.

Correlation names

A *correlation name* can be defined in the FROM clause of a query and after the name of the target table or view in an UPDATE, MERGE, or DELETE statement.

For example, the following clause establishes Z as a correlation name for X.MYTABLE:

```
FROM X.MYTABLE Z
```

With Z defined as a correlation name for table X.MYTABLE, only Z should be used to qualify a reference to a column of X.MYTABLE in that SELECT statement.

A correlation name is associated with a table, view, nested table expression or table function only within the context in which it is defined. Hence, the same correlation name can be defined for different purposes in different statements. In a nested table expression or table function, a correlation name is required.

As a qualifier, a correlation name can be used to avoid ambiguity or to establish a correlated reference. It can also be used merely as a shorter name for a table or view. In the example, Z might have been used merely to avoid having to enter X.MYTABLE more than once.

Names that are specified in a FROM clause are either *exposed* or *non-exposed*. A correlation name is always an exposed name. A table name or view name is said to be exposed in that FROM clause if a correlation name is not specified. For example, in the following FROM clause, a correlation name is specified for EMPLOYEE, but not for DEPARTMENT; therefore, DEPARTMENT is an exposed name, and EMPLOYEE is not an exposed name:

```
FROM EMPLOYEE E, DEPARTMENT
```

The use of a correlation name in the FROM clause also allows the option of specifying a list of column names to be associated with the columns of the result table. As with a correlation name, the listed

column names should be the names that are used to reference the columns in that SELECT statement. For example, assume that the name of the first column in the DEPT table is DEPTNO. Given this FROM clause in a SELECT statement:

```
FROM DEPT D (NUM, NAME, MGR, ANUM, LOC)
```

You should use D.NUM instead of D.DEPTNO to reference the first column of the table.

If a list of columns is specified, it must consist of as many names as there are columns in the *table-reference*. Each column must be unique and unqualified.

Column name qualifiers to avoid ambiguity

In the context of a function, a GROUP BY clause, an ORDER BY clause, an expression, or a search condition, a column name refers to values of a column in some table or view in a DELETE, MERGE, or UPDATE statement or *table-reference* in a FROM clause.

The tables, views, and *table-references*¹² that might contain the column are called the *object tables* of the context. Two or more object tables might contain columns with the same name. One reason for qualifying a column name is to designate the object from which the column comes. For information on avoiding ambiguity between SQL parameters and variables and column names, see [“References to SQL parameters and SQL variables in external SQL procedures”](#) on page 2280.

A nested table expression which is preceded by a TABLE keyword will consider *table-references* that precede it in the FROM clause as object tables. The *table-references* that follow it are not considered as object tables.

Table designators: A qualifier that designates a specific object table is called a *table designator*. The clause that identifies the object tables also establishes the table designators for them. For example, the object tables of an expression in a SELECT statement are named in the FROM clause that follows it, as in the following statement:

```
SELECT DISTINCT Z.EMPNO, EMPTIME, PHONENO
FROM DSN8C10.EMP Z, DSN8C10.EMPPROJACT
WHERE WORKDEPT = 'D11'
AND EMPTIME > 0.5
AND Z.EMPNO = DSN8C10.EMPPROJACT.EMPNO;
```

Table designators in the FROM clause are established as follows:

- A name that follows a table or view name is both a correlation name and a table designator. Thus, Z is a table designator and qualifies the first column name in the select list.
- An exposed table or view name is a table designator. Thus, the qualified table name, DSN8C10.EMPPROJACT is a table designator and qualifies the second column name in the select list.

Two or more object tables can be instances of the same table. In this case, distinct correlation names must be used to unambiguously designate the particular instance of the table. In the following example, the X and Y in the FROM clause are defined to refer, respectively, to the first and second instances of the DSN8C10.EMP table:

```
SELECT *
FROM DSN8C10.EMP X, DSN8C10.EMP Y;
```

Avoiding undefined or ambiguous references in Db2 SQL: When a column name refers to values of a column, the following situations result in errors:

- No object table contains a column with the specified name. The reference is undefined.
- The column name is qualified by a table designator, but the table named does not include a column with the specified name. Again, the reference is undefined.
- The name is unqualified and more than one object table includes a column with that name. The reference is ambiguous.

¹² In the case of a *joined-table*, each *table-reference* within the *joined-table* is an object table.

Avoid ambiguous references by qualifying a column name with a uniquely defined table designator. If the column is contained in several object tables with different names, the table names can be used as designators. Ambiguous references can also be avoided without the use of the table designator by giving unique names to the columns of one of the object tables using the column name list following the correlation name.

Two or more object tables can be instances of the same table. A FROM clause that includes n references to the same table should include at least $n - 1$ unique correlation names.

For example, in the following FROM clause X and Y are defined to refer, respectively, to the first and second instances of the table EMP.

```
SELECT X.LASTNAME, Y.LASTNAME
FROM DSN8C10.EMP X, DSN8C10.EMP Y
WHERE Y.JOB = 'MANAGER'
AND X.WORKDEPT = Y.WORKDEPT
AND X.JOB <> 'MANAGER';
```

When qualifying a column with the exposed table name form of a table designator, either the qualified or unqualified form of the exposed table name can be used. However, the qualifier used and the table used must be the same after fully qualifying the table name or view name and the table designator.

Example 1: If the authorization ID of the statement is CORPDATA, the following statement is valid:

```
SELECT CORPDATA.EMPLOYEE.WORKDEPT
FROM EMPLOYEE;
```

Example 2: If the authorization ID of the statement is REGION, the following statement is invalid because EMPLOYEE represents the table REGION.EMPLOYEE, but the qualifier for WORKDEPT represents a different table, CORPDATA.EMPLOYEE:

```
SELECT CORPDATA.EMPLOYEE.WORKDEPT          -- Incorrect
FROM EMPLOYEE;
```

Example 3: If the authorization ID of the statement is REGION, the following statement is invalid because EMPLOYEE in the select list represents the table REGION.EMPLOYEE, but the explicitly qualified table name in the FROM clause represents a different table, CORPDATA.EMPLOYEE.

```
SELECT EMPLOYEE.WORKDEPT                    -- Incorrect
FROM CORPDATA.EMPLOYEE;
```

Column name qualifiers in correlated references

A reference to a column of a table identified at a higher level is called a *correlated reference*. Because the same table or view can be identified at many levels, unique correlation names are recommended as table designators. It is good practice to use these unique correlation names to qualify column names.

A *subselect* is a form of a query that can be used as a component of various SQL statements. A *subquery* is a form of a fullselect that is enclosed within parenthesis. For example, a subquery can be used in a search condition. A fullselect that is used to retrieve a single value as an expression within a statement is called a *scalar fullselect* or a *scalar subquery*. A fullselect that is used in the FROM clause of a query is called a *nested table expression*.

A subquery can include search conditions of its own, and these search conditions can, in turn, include subqueries. Thus, an SQL statement can contain a hierarchy of subqueries. Those elements of the hierarchy that contain subqueries are said to be at a higher level than the subqueries they contain.

Every element of the hierarchy has a clause that establishes one or more table designators. This is the FROM clause, except in the highest level of a MERGE or UPDATE, where it is the table or view being updated. A search condition of a subquery can reference not only columns of the tables identified by the FROM clause of its own element of the hierarchy, but also columns of tables identified at any level along the path from its own element to the highest level of the hierarchy.

A correlated reference to column C of table T can be of the form C, T.C, or Q.C, if Q is a correlation name defined for T. However, **a correlated reference in the form of an unqualified column name is not good practice**. The following explanation is based on the assumption that a correlated reference is always in the form of a qualified column name and that the qualifier is a correlation name.

A qualified column name, Q.C, is a correlated reference only if these three conditions are met:

- Q.C is used in a search condition or in a select list of a subquery.
- Q does not name a table used in the FROM clause of that subquery.
- Q does name a table used at some higher level.

Q.C refers to column C of the table or view at the level where Q is used as the table designator of that table or view. Because the same table or view can be identified at many levels, unique correlation names are recommended as table designators. If Q is used to name a table at more than one level, Q.C refers to the lowest level that contains the subquery that includes Q.C.

If a correlation name is defined as the table designator of the table or view, but the table or view name is used as the column qualifier instead of the correlation name, an error is returned.

For example, in the following statement, the correlated reference X.WORKDEPT (in the last line) refers to the value of WORKDEPT in table DSN8C10.EMP at the level of the first FROM clause (which establishes X as a correlation name for DSN8C10.EMP.). The statement lists employees who make less than the average salary for their department.

```
SELECT EMPNO, LASTNAME, WORKDEPT
FROM DSN8C10.EMP X
WHERE SALARY < (SELECT AVG(SALARY)
                FROM DSN8C10.EMP
                WHERE WORKDEPT = X.WORKDEPT);
```

The following example shows a correlated reference in the select list of the subquery.

```
SELECT T1.KEY1
FROM BP1TBL T1
GROUP BY T1.KEY1
HAVING MAX(T1.KEY1) = (SELECT MIN(T1.KEY1) + MIN(T2.KEY1)
                      FROM BP2TBL T2);
```

Related concepts

Queries

A *query* specifies a result table or an intermediate table. A query is a component of certain SQL statements.

Resolution of column name qualifiers and column names

The rules for resolving column name qualifiers apply to every SQL statement that includes a subselect and are applied before synonyms and aliases are resolved.

Names in a FROM clause are either *exposed* or *non-exposed*. A correlation name for a table name, view name, nested table expression, or reference to a table function is always exposed. A table name or a view name that is not followed by a correlation name is also exposed.

Although Db2 for z/OS does not enforce this rule strictly, in IBM SQL and ANSI/ISO SQL, the exposed names in a FROM clause must be unique, and the qualifier of a column name must be an exposed name. Therefore, for good programming practices, ensure that all exposed names are unique and that all qualified column names are qualified with the appropriate exposed name.

The rules for finding the referent of a column name qualifier are as follows:

1. Let Q be a one-, two-, or three-part name, and let Q.C denote a column name in subselect S. Q must designate a table or view identified in the statement that includes S and that table or view must have a column named C. An additional requirement differs for two cases:

- If Q.C is not in a *search-condition* or S is not a subquery, Q must designate a table or view identified in the FROM clause of S. For example, if Q.C is in a SELECT clause, Q refers to a table or view in the following FROM clause.
 - If Q.C is in a *search-condition* and S is a subquery, Q must designate a table or view identified either in the FROM clause of S or in a FROM clause of a subselect that directly or indirectly includes S. For example, if Q.C is in a WHERE clause and S is the only subquery in the statement, the table or view that Q refers to is either in the FROM clause of S or the FROM clause of the subselect that includes S.
2. The same table or view can be identified more than once in the same statement. The particular occurrence of the table or view that Q refers to is determined by a procedure equivalent to the following steps:
- a. The one- and two-part names in every FROM clause and the one- and two-part qualifiers of column names are expanded into a fully-qualified form.

For example, if a dynamic SQL statement uses FROM Q and DYNAMICRULES run behavior (RUN) is in effect, Q is expanded to S.A.Q, where S is the value of CURRENT SERVER and A is the value of CURRENT SCHEMA. (If DYNAMICRULES bind behavior is in effect instead, A is the plan or package qualifier as determined during the bind process or the qualifier for the native SQL procedure as determined when the procedure was defined.) This step is later referred to as "name completion". An error occurs if the first part of every name (the location) is not the same.
 - b. Q, now a three-part name, is compared with every name in the FROM clause of S. If Q.C is in a *search-condition* and S is a subquery, Q is next compared with every name in the FROM clause of the subselect that contains S. If that subselect is a subquery, Q is then compared with every name in the FROM clause of the subselect containing that subquery, and so on. If a FROM clause includes multiple names, the comparisons in that clause are made in order from left to right.
 - c. The referent of Q is selected by these rules:
 - If Q matches exactly one name, that name is selected.
 - If Q matches more than one name, but only one exposed name, that exposed name is selected.
 - If Q matches more than one exposed name, the first of those names is selected.
 - If Q matches more than one name, none of which are exposed names, the first of those names is selected.

If Q does not match any name, or if the table or view designated by Q does not include a column named C, an error occurs.
 - d. Otherwise, Q.C is resolved to column C of the occurrence of the table or view identified by the selected name.
3. A warning occurs for any of these cases:
- The selected name is not an exposed name.
 - The selected name is an exposed name that has an unexposed duplicate that appears before the selected name in the ordered list of names to which Q is compared.
 - The selected name is an exposed name that has an exposed duplicate in the same FROM clause.
 - Another name would have been selected had the matching been performed before name completion.

The rules for resolving column name qualifiers apply to every SQL statement that includes a subselect and are applied before synonyms and aliases are resolved. In the case of a searched UPDATE or DELETE statement, or a MERGE statement, the first clause of the statement identifies the table or view to be changed. That clause can include a correlation name and, with regard to name resolution, is equivalent to the first FROM clause of a SELECT statement. For example, a subquery in the search condition of an UPDATE statement can include a correlated reference to a column of the updated rows.

The rules for column names in the ORDER BY clause are the same as other clauses.

Variables

A *variable* in an SQL statement specifies a value that can be changed when the SQL statement is executed. There are several types of variables used in SQL statements.

Global variables

Global variables are either built-in global variables or user-defined global variables. For more information about global variables, see [“Global variables” on page 225](#).

Session variables

Session variables are either built-in session variables or user-defined session variables. For more information about session variables, see [“Session variables” on page 227](#).

Host variables

Host variables are defined by statements of a host language. For more information about how to refer to host variables, see [“Host variables” on page 227](#).

Transition variables

Transition variables are defined in a trigger and refer to either the old or new values of columns of the subject table or view of a trigger. For more information about how to refer to transition variables, see [“CREATE TRIGGER statement \(basic trigger\)” on page 1769](#).

SQL variables

SQL variables are defined by an SQL compound statement in an SQL function or SQL procedure. For more information about SQL variables, see [“References to SQL parameters and variables in SQL PL” on page 2208](#).

SQL parameters

SQL parameters are defined in an CREATE FUNCTION (SQL Scalar), CREATE FUNCTION (SQL table), or CREATE PROCEDURE (SQL) statement. For more information about SQL parameters, see [“References to SQL parameters and variables in SQL PL” on page 2208](#).

Parameter markers

Parameter markers are specified in an SQL statement that is dynamically prepared, instead of variables, other than global variables. For more information about parameter markers, see [Parameter markers in the PREPARE statement](#).

Unless otherwise noted, the term *variable* in syntax diagrams is used to describe where a global variable, host variable, transition variable, SQL variable, SQL parameter, or parameter marker can be used.

Global variables

A global variable is a named memory variable that you access through SQL statements. Global variables let you share relational data between SQL statements without the need for application logic to support this data transfer.

The Db2 database management system supports the following types of global variables:

Built-in global variable

Built-in global variables are provided with the database manager and are used in SQL statements to retrieve scalar values associated with the variables. A built-in global variable is available to any SQL statement that runs on the database manager. Built-in global variables reside in the SYSIBM and SYSIBMADM schemas. As an example, the CLIENT_IPADDR built-in global variable can be referenced in an SQL statement to retrieve the IP address of the current client.

For a list of the built-in global variables and information on these variables, see [“Built-in global variables” on page 329](#).

The READ privilege on a built-in global variable is required for any statement that retrieves the value of that variable. The READ privilege for the built-in global variables is implicitly granted to PUBLIC during installation.

The WRITE privilege on an updatable built-in global variable is required for any statement that assigns a value to that variable. You can control write access to an updatable built-in global variable through the GRANT (variable privileges) and REVOKE (variable privileges) statements.

Examples: Using built- in global variables

The value of a built-in global variable can be obtained by referencing the variable in the context in which the value is needed.

```
SELECT C1, C2
FROM T1
WHERE C3 = CLIENT_IPADDR
```

To access the global variable CLIENT_HOST, run the following query:

```
SELECT SYSIBM.CLIENT_IPADDR
FROM SYSIBM.SYSDUMMY1
```

The query returns the IP address of the current client.

```
1111:2222:3333:4444:5555:6666:7777:8888
```

To change the value of an updatable built-in global variable, issue the "SET variable" statement:

```
SET SYSIBMADM.GET_ARCHIVE = 'Y'
```

User-defined global variable

A user-defined global variable is available to any active SQL statement that is running on the database manager on which the variable was defined. The value of a user-defined global variable is associated with a specific session, and contains a value that is unique to that session. User-defined global variables let users extend the functionality of the database management system by adding their own or third-party vendor variable definitions.

A user-defined global variable is created using the CREATE VARIABLE statement, and registered to the database manager in the catalog. A user-defined global variable resides in the schema in which it was created. For more information, see [“CREATE VARIABLE statement” on page 1808](#).

You can control access to a user-defined global variable through the [“GRANT statement \(variable privileges\)” on page 1992](#) and [“REVOKE \(variable privileges\)” on page 2106](#) statements. The authorization that is required to use a global variable depends on where it is defined and how it is used.

- The authorization ID of an SQL statement that references a user-defined global variable and retrieves the value must have the READ privilege on the global variable.
- The authorization ID of an SQL statement that references a user-defined global variable and assigns a value to that variable must have the WRITE privilege on the global variable.

The value of a user-defined global variable can be obtained by referencing the variable in the context in which the value is needed. The value of a user-defined global variable can be changed with the following statements:

- EXECUTE
- FETCH
- SET
- SELECT INTO
- VALUES INTO
- CALL, if the variable is an argument to a procedure in which the corresponding parameter is defined as an OUT or INOUT parameter.

A reference, with an unqualified name, that is intended to resolve to a global variable could also resolve to an SQL variable, an SQL parameter, or even a column name, depending on the context of the reference and how the reference is qualified within that context. The implicit schema name for an unqualified variable name depends on the context in which the name appears:

- If an unqualified variable name is used in a CREATE VARIABLE, or the object of a DROP, COMMENT, GRANT, or REVOKE statement, the normal process of qualification by the authorization ID is used to determine the schema name.
- If an unqualified variable name is used in any other context, the SQL path is used to determine the schema name. The database manager searches the schemas in the SQL path in sequence. The schema that is selected is the first schema in the SQL path for which the global variable exists in the schema, and the user has authorization to use the variable. For a description of the SQL path, see [“SQL path”](#) on page 85.

Session variables

A session variable is a named memory variable that you access through SQL statements. Session variables let you share data between SQL statements without the need for application logic to support this data transfer.

The Db2 for z/OS supports the following types of session variables:

Built-in session variables

Built-in session variables are provided with the database manager. The value of a built-in session variable can be obtained by invoking the GETVARIABLE built-in function to retrieve the scalar value associated with the variable.

For more information about built-in session variables, see [“Built-in session variables”](#) on page 336.

User-defined session variables

User-defined session variables can be defined in connection and sign-on routines. A user-defined session variable is available to any active SQL statement that is running on the database manager on which the variable was defined. The value of a user-defined session variable is associated with a specific session and contains a value that is unique to that session. User-defined session variables let users extend the functionality of the database management system by adding their own or third-party vendor variable definitions.

Up to 10 user-defined session variables can be defined in the connection exit routine and the sign-on exit routine. For more information about defining user-defined session variables, see [Session variables in connection and sign-on routines \(Managing Security\)](#).

You can obtain the value of a user-defined or built-in session variable by invoking the GETVARIABLE function with the name of the session variable. For more information on retrieving the value of a session variable, see [“GETVARIABLE scalar function”](#) on page 464.

Host variables

Host variables are defined directly by statements of the host language or indirectly by SQL extensions. A *host-variable* in an SQL statement must identify a host variable that is described in the program according to the rules for declaring host variables. Host variables cannot be referenced in dynamic SQL statements; parameter markers must be used instead.

A *host variable* is either of these items that is referred to in an SQL statement:

- A variable in a host language such as a PL/I variable, C variable, Fortran variable, REXX variable, Java variable, COBOL data item, or Assembler language storage area
- A host language construct that was generated by an SQL precompiler from a variable declared using SQL extensions

Host variables are defined directly by statements in the host language or indirectly by SQL extensions as described in [Db2 object relational extensions \(Db2 Application programming and SQL\)](#). Host variables cannot be referenced in dynamic SQL statements; parameter markers must be used instead. For more information about parameter markers, see [“Variables in dynamic SQL”](#) on page 230.

A *host-variable* in an SQL statement must identify a host variable that is described in the program according to the rules for declaring host variables.

In PL/I, C, and COBOL, host variables can be referred to in ways that do not apply to Fortran and Assembler language. This is explained in [“Host structures in PL/I, C, and COBOL”](#) on page 235. The following applies to all host languages.

The term *host-variable*, as used in the syntax diagrams, shows a reference to a host variable. In a SET *host variable* statement and the INTO clause of a FETCH, SELECT INTO, or VALUES INTO statement, a host variable is an output variable to which a value is assigned by Db2. In a CALL statement, a host variable can be an output argument that is assigned a value after execution of the procedure, an input argument that provides an input value for the procedure, or both an input and output argument. In all other contexts, a host variable is an input variable which provides a value to Db2.

Non-Java variable references

The general form of a host variable reference in all languages other than Java is:

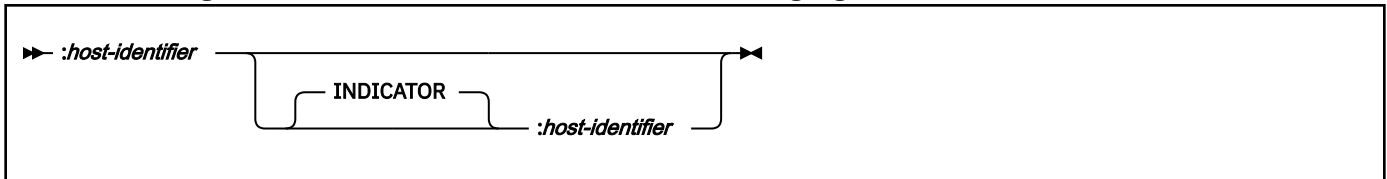

Each host identifier must be declared in the source program, except in a program written in REXX. The first *host-identifier* designates the main variable, and the second *host-identifier* designates the associated *indicator variable*. An indicator variable must be a small integer. Depending on the operation, the main variable either provides a value to the database manager or is provided a value from the database manager. An input host variable provides a value in the runtime application code page. An output host variable is provided a value that, if necessary, is converted to the runtime application code page when the data is copied to the output application variable. A given host variable can serve as both an input and an output variable in the same program.

The purposes of an indicator variable are to:

- Specify a non-null value. A 0 (zero), or positive value of the indicator variable specifies that the associated, first *host-identifier* provides the value of this host variable reference.
- Specify the null value. A negative value of the indicator variable specifies the null value.

In addition, on output, the purposes of an indicator variable are to:

- Indicate that a numeric conversion error (such as a divide by 0 or overflow) has occurred. A value of -2 for the indicator variable indicates a null result because of either numeric truncation or arithmetic warnings.
- Indicate that a character could not be converted. A value of -2 for the indicator variable indicates a null result because of character string conversion warnings.
- Indicate that no value was returned. A value of -3 for the indicator variable indicates a null result because the current row of the cursor is on a hole that is detected during a multiple row FETCH.
- Report the original length of a truncated string, if the string is not a LOB.
- Report the seconds portion of a time if the time is truncated on assignment to a host variable.

If the second *host-identifier* is omitted, the host variable does not have an indicator variable. The value specified by the host variable V1 is always the value of V1, and null values cannot be assigned to the variable. Thus, do not use this form on output unless the corresponding result column cannot contain null values. If this form is used for an output host variable, and the returned value is null, Db2 returns an error at run time.

An indicator variable for an input host variable in an INSERT, MERGE, or UPDATE statement can also be set to some special values to indicate that a target column is to be set to the default value, or to indicate that a value should not be assigned to a target column. These special values are only allowed when extended indicators are enabled. Extended indicators are enabled when the EXTENDEDINDICATOR(YES) bind option is used, or when the WITH EXTENDED INDICATORS prepare attribute is specified for the statement.

When extended indicators are enabled, an input indicator variable for an assignment in an INSERT, MERGE, or UPDATE statement specifies that the target column for the associated host variable is assigned one of the following types of values:

- A non-null value: A 0 (zero), or positive value specifies that the associated *host-identifier* provides the value of this host variable reference.
- NULL: A -1, -2, -3, -4, or -6 value specifies the null value.
- DEFAULT: A -5 value specifies the default value of the target column.
- UNASSIGNED: A -7 value specifies that this host variable is treated as if a value was not specified for assignment to the target column in the statement.

These indicator values can also be used in indicator structures with host structures. When extended indicators are enabled, indicator values other than positive values, zero, and the negative values listed previously must not be used. The DEFAULT and UNASSIGNED extended indicator values must only be used in contexts where they are supported (INSERT, MERGE, and UPDATE statements). The DEFAULT and UNASSIGNED extended indicator values can only be used for an expression containing a single host parameter or a CAST of a single host parameter that is being assigned to a column. Output indicators are never set to extended indicator values.

When extended indicators are enabled, rules for data type validation in assignment and comparison are loosened for a host variable for which the associated indicator value is negative. Data type assignment and comparison validation rules are not enforced for a host variable for which the associated indicator value is NULL, DEFAULT, or ASSIGNED.

An SQL statement that references host variables must be within the scope of the declaration of those host variables. For host variables referenced in the SELECT statement of a cursor, that rule applies to the OPEN statement rather than to the DECLARE CURSOR statement.

The CCSID of a string host variable is one of the following values:

- If a DECLARE VARIABLE statement with a CCSID clause for the host variable is specified, the CCSID of the host variable is the CCSID in the DECLARE VARIABLE statement.
- If a DECLARE VARIABLE statement with a CCSID clause is not specified for the host variable, the host variable CCSID is the default CCSID of the application requester at the time that the SQL statement that contains the host variable is executed, unless the CCSID is for a foreign encoding scheme. In that case, the host variable is converted to the default CCSID of the current server.

All references to host variables must be preceded by a colon. If an SQL statement references a host variable without a preceding colon, the precompiler issues an error for the missing colon or interprets the host variable as an unqualified column name, which might lead to unintended results. The interpretation of a host variable without a colon as a column name occurs when the host variable is referenced in a context in which a column name can also be referenced.

Java variable references

The general form of a host variable reference in Java is:

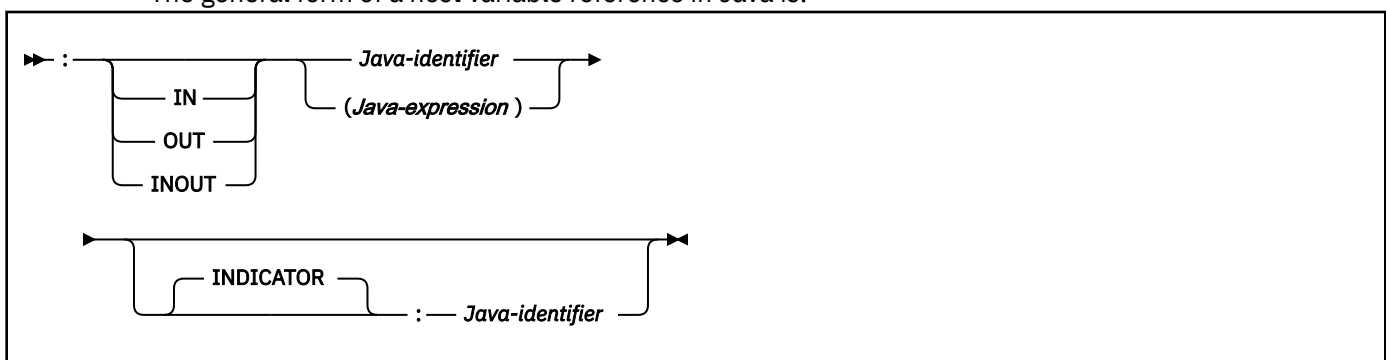

Each Java-identifier must be declared in the source program. The variable designated by the second Java-identifier is called an indicator variable and must be a short.

In Java, indicator variables are not always needed. Instead, instances of a Java class can be set to a null value. Variables defined as Java primitive types can not be set to a null value. When using an extended indicator variable, or when using a Java primitive type in assigning a null value or where the Java primitive type might be assigned null on output, indicator variables must be used.

If IN, OUT, or INOUT is not specified, the default depends on the context in which the variable is used. If the Java variable is used in an INTO clause, OUT is the default. Otherwise, IN is the default.

Variables in dynamic SQL

In dynamic SQL statements, parameter markers are used instead of variables other than global variables. Global variables are the only type of variable that can be specified in a dynamic SQL statement.

A *parameter marker* is a question mark (?) that represents a position in a dynamic SQL statement where the application will provide a value; that is, where a variable would be found if the statement string were a static SQL statement. The following examples show a static SQL statement that uses variables and a dynamic statement that uses parameter markers:

```
INSERT INTO DEPT VALUES (:HV_DEPTNO, :HV_DEPTNAME, :HV_MGRNO, :HV_ADMRDEPT)
INSERT INTO DEPT VALUES (?, ?, ?, ?)
```

For more information on parameter markers, see [Parameter markers](#) under the PREPARE statement.

LOB variables

Regular LOB variables (CLOB, DBCLOB, and BLOB), LOB locator variables and LOB file reference variables can be defined in all host languages with a few exceptions.

- Java supports file reference variables, but not locators for LOBs.

Where LOBs are allowed, the term meta-variable *variable* in a syntax diagram can refer to a regular variable, a locator variable, or a file reference variable. Because these variables are not native data types in host programming languages, SQL extensions are used, and the precompilers generate the host language constructs that are necessary to represent each variable.

When it is possible to define a variable that is large enough to hold an entire LOB value and the performance benefit of delaying the transfer of data from the server is not required, a LOB locator or LOB file reference is not needed. However, it is often not acceptable to store an entire LOB value in temporary storage due to host language restrictions, storage restrictions, or performance requirements. When storing an entire LOB value at one time is not acceptable, you can use one of the following alternatives:

- Referencing the LOB value using a LOB locator, and accessing portions of the value
- Storing the entire LOB value in a file, and using a LOB file reference to access the data

LOB locator variables

A LOB locator variable is a host variable that contains the locator representing a LOB value on the database server.

See “[Manipulating LOBs using locators](#)” on page 117 for information about how locators can be used to manipulate LOB values.

A locator variable in an SQL statement must identify a LOB locator variable described in the program according to the rules for declaring locator variables. This is always indirectly through an SQL statement. For example, in C:

```
static volatile SQL TYPE IS CLOB_LOCATOR *loc1;
```

The term *locator-variable*, as used in the syntax diagrams, shows a reference to a LOB locator variable. The meta-variable *locator-variable* can be expanded to include a *host-identifier* the same as that for *host-variable*.

Like all other host variables, a LOB locator variable can have an associated indicator variable. Indicator variables for LOB locator variables behave in the same way as indicator variables for other data types. When a null value is returned from the database, the indicator variable is set and the locator host variable is unchanged. This means a locator can never represent a null value. However, when the indicator variable associated with a LOB locator is null, the value of the referenced LOB value is null.

If a locator variable does not currently represent any value, an error occurs when the locator variable is referenced.

When a transaction commits, LOB locators that were acquired by the transaction are released unless a HOLD LOCATOR statement was issued for the LOB locator. When the transaction ends, all LOB locators are released.

It is the application programmer's responsibility to guarantee that any LOB locator is used only in SQL statements that are executed at the same server that originally generated the LOB locator. For example, assume that a LOB locator is returned from one server and assigned to a LOB locator variable. If that LOB locator variable is subsequently used in an SQL statement that is executed at a different server unpredictable results will occur.

XML variables

An XML variable can be defined as a string or file reference variable. Regular XML variables and XML file reference variables can be defined in all host languages with a few exceptions.

- REXX supports file reference variables for XML.
- Java supports XML and file reference variables for XML.

XML variables can be declared as the following variable types:

Where XML variables are allowed, the meta-variable *variable* in a syntax diagram can refer to a regular variable or a file reference variable. Because these variables are not native data types in host programming languages, SQL extensions are used, and the precompilers generate the host language constructs that are necessary to represent each variable.

When it is possible to define a variable that is large enough to hold an entire XML value and the performance benefit of delaying the transfer of data from the server is not required, an XML file reference is not needed. However, it is often not acceptable to store an entire XML value in temporary storage due to host language restrictions, storage restrictions, or performance requirements. When storing an entire XML value at one time is not acceptable, portions of the value can be accessed, or the entire value can be stored in a file. When the entire value is stored in a file, an XML file reference can be used to access the data.

XML host variables can be declared as the following variable types:

- XML AS CLOB(*n*)
Declares a CLOB variable that contains XML data that is encoded in the CCSID for the variable.
- XML AS DBCLOB(*n*)
Declares a DBCLOB variable that contains XML data that is encoded in the graphic CCSID for the variable.
- XML AS BLOB(*n*)
Declares a BLOB variable that contains XML data that is encoded as specified within the data according to the XML 1.0 specification for determining encoding.
- XML AS CLOB_FILE
Declares a CLOB file reference variable that contains XML data that is encoded in the CCSID for the file reference variable.
- XML AS DBCLOB_FILE
Declares a DBCLOB file reference variable that contains XML data that is encoded in the CCSID for the file reference variable.

- XML AS BLOB_FILE

Declares a BLOB file reference variable that contains XML data that is encoded in the CCSID for the file reference variable.

See “LOB or XML file reference variables ” on page 232 for additional information about file reference variables.

Although the application XML variable declaration includes a LOB type specification, the variable declarations all are considered to be the XML data type, not the LOB type that is used in the application declaration. The application might also use non-XML variables in place of XML variables. For example, when a prepared statement is executed, the application might use a character variable to replace an XML parameter marker in the statement.

Although the XML data type is incompatible with all other data types, both XML and non-XML data types can be used for input to and output from XML data. Applications can use either XML variables, character variables, or binary string variables for input and output in SQL statements for XML data.

The following table summarizes the conversions built-in data types (including XML) to and from the supported variable data types within embedded applications. The built-in data types are specified in the rows. A Y indicates that the built-in data type can be assigned to or assigned from the variable type.

Table 48. Application variable compatibility with the built-in data types for applications that contain embedded SQL

built-in data type	application variable data type					
	CHAR, VARCHAR, CLOB, CLOB_FILE	GRAPHIC, VARGRAPHIC, DBCLOB, DBCLOB_FILE	BINARY, VARBINARY, BLOB, BLOB_FILE	XML AS CLOB, XML AS CLOB_FILE	XML AS DBCLOB, XML AS DBCLOB_FILE	XML AS BLOB, XML AS BLOB_FILE
CHAR	Y	Y				
VARCHAR	Y	Y				
CLOB	Y	Y				
GRAPHIC	Y	Y				
VARGRAPHIC	Y	Y				
DBCLOB	Y	Y				
BINARY			Y			
VARBINARY			Y			
BLOB			Y			
XML	Y	Y	Y	Y	Y	Y

LOB or XML file reference variables

File reference variables are used for direct file input and output for LOB and XML values (when the XML value is declared using XML AS *variable-type*), and can be defined in all host languages.

Because these are not native data types, SQL extensions are used and the Db2 precompiler or coprocessor generates the host language constructs necessary to represent each variable. In the case of REXX, LOB values are mapped to strings. See “XML variables” on page 231 for more information about XML host variables.

A file reference variable represents (rather than contains) the file, just as a LOB locator represents, rather than contains, the LOB data. Database queries, updates, and inserts can use file reference variables to store or to retrieve single column values.

As with all other host variables, file reference variables can have an associated indicator variable. Indicator variables for file reference variables behave in the same way as indicator variables for other data types. When a null value is returned from the database manager, the indicator variable is set, and the variable is unchanged. When the indicator variable that is associated with a file reference variable is null,

the value of the referenced LOB or XML object is null. This means that a file reference variable can never point to a null value.

The length attribute of a file reference variable is assumed to be the maximum length of a LOB or XML object.

A file reference variable has the following properties:

Data type

BLOB, CLOB, or DBCLOB. This property is specified when the variable is declared using BLOB_FILE, CLOB_FILE, or DBCLOB_FILE.

Direction

This must be specified by the application program at run time (it is implicitly specified as part of the File options value). The direction can be either of the following:

Input

Input is used as a source of data on an EXECUTE statement, an OPEN statement, an update operation, an insert operation, or a delete operation.

Output

Output is used as the target of data. For example, on a FETCH statement or a SELECT INTO statement.

File name

This must be specified by the application program at run time. It must be the complete path name of the file. Within an application, a file should only be referenced one time in a file reference variable.

File name length

This must be specified by the application program at run time. It is the length of the file name in bytes.

Data length

Sets the data length to the length of the new data that is written to the file. The length is in bytes. Data length is unused on input.

File options

Options are set by an INTEGER value in a field in the file reference variable structure. One of the following values must be specified in an application for each file reference variable before that file reference variable can be used in the application:

SQL_FILE_READ

This is a regular file that can be opened, read and closed. (The option is SQL-FILE-READ in COBOL, sql_file_read in FORTRAN, and READ in REXX.) SQL_FILE_READ is an input (from client to server) file option.

SQL_FILE_CREATE

Create a new file. If the file already exists, an error is returned. (The option is SQL-FILE-CREATE in COBOL, sql_file_create in FORTRAN, and CREATE in REXX.) SQL_FILE_CREATE is an output (from server to client) file option.

SQL_FILE_OVERWRITE

If an existing file with the specified name exists, it is overwritten; otherwise a new file is created. (The option is SQL-FILE-OVERWRITE in COBOL, sql_file_overwrite in FORTRAN, and OVERWRITE in REXX.) SQL_FILE_OVERWRITE is an output (from server to client) file option.

SQL_FILE_APPEND

If an existing file with the specified name exists, the output is appended to it; otherwise a new file is created. (The option is SQL-FILE-APPEND in COBOL, sql_file_append in FORTRAN, and APPEND in REXX.) SQL_FILE_APPEND is an output (from server to client) file option.

The encoding scheme CCSID of the file name is based on the encoding scheme of the application. The CCSID of the LOB or XML data (the contents of the file) can be set by the application by using a DECLARE *host-variable* CCSID statement if the CCSID of the LOB or XML data is different from the CCSID of the application. Db2 performs any character conversion that is required prior to insertion of the LOB or XML data into a table or writing of the LOB or XML data to a file.

Result set locator variables

A *result set locator variable* is a variable that contains the locator that identifies a stored procedure result set. A result set locator variable in an SQL statement must identify a result set locator variable described in the program according to the rules for declaring result set locator variables. This is always indirectly through an SQL statement.

For example, in C:

```
static volatile SQL TYPE IS RESULT_SET_LOCATOR VARYING *loc1;
```

A result set locator variable in an SQL procedure is defined with the `RESULT_SET_LOCATOR VARYING` clause in a compound statement.

The meta-variable *rs-locator-variable*, as used in the syntax diagrams, shows a reference to a result set locator variable. A host variable that is a result set locator variable can have an association indicator variable. When the indicator variable that is associated with a result set locator is null, the referenced result set is not defined.

If a result set locator variable does not currently represent any stored procedure result set, an error occurs when the locator variable is referenced.

A commit operation destroys all open cursors that were declared in the stored procedure without the `WITH HOLD` option and the result set locators that are associated with those cursors. Otherwise, a cursor and its associated result set locator persist past the commit.

An application that is written in a programming language other than Java can access a result set that is returned from a stored procedure. A result set locator is used by the invoking application to access the result set. A result set locator value for a result set can be obtained from an `ASSOCIATE LOCATOR LOCATORS` statement or with the `DESCRIBE PROCEDURE` statement. For more information, see [“ASSOCIATE LOCATORS statement” on page 1380](#) and [“DESCRIBE PROCEDURE statement” on page 1879](#).

The result set locator value is specified on an `ALLOCATE CURSOR` statement to define a cursor in the invoking application and to associate it with a stored procedure result set. For more information, see [“ALLOCATE CURSOR statement” on page 1093](#).

A `DESCRIBE CURSOR` statement can be used in the invoking application to obtain information on the characteristics of the columns of a stored procedure result set. For more information, see [“DESCRIBE CURSOR statement” on page 1869](#).

The application can then access the rows of the result set using `FETCH` statements with the allocated cursor.

Related reference

compound-statement

A compound statement groups other statements together in an SQL routine or advanced trigger. A compound statement allows the declaration of SQL variables, cursors, and condition handlers.

Array variables

An array variable is a variable that is defined as a user-defined array type.

An array variable can be defined in one of the following ways:

- An array global variable that is defined using the `CREATE VARIABLE` statement.
- An SQL parameter that is defined using the `CREATE FUNCTION (SQL scalar)` or `CREATE PROCEDURE (SQL native)` statement.
- An SQL variable that is defined using the `DECLARE` clause of a compound statement.

An array variable (representing an entire array) can be referenced in the following contexts:

- An input argument to the `NULL` predicate.
- An input argument to the `ARRAY_EXISTS` predicate.

- An input argument to a built-in array scalar function (ARRAY_DELETE, ARRAY_FIRST, ARRAY_LAST, ARRAY_NEXT, ARRAY_PRIOR, or TRIM_ARRAY).
- An argument to UNNEST specification.
- The outer SELECT list of a fullselect that does not include a set operator, in the definition of a cursor that is not scrollable. In this case a FETCH statement for the cursor must specify an array variable as the target for the corresponding result column of the fullselect for the array variable.
- The outer select list of a SELECT INTO statement, when the target for the corresponding column of the result table of the fullselect is an array variable.
- The outer select list of a scalar fullselect, on the right side of a SET *assignment-statement* statement or an SQL PL *assignment-statement* statement, when the corresponding target of the assignment is an array variable.
- The source value for a VALUES INTO statement, when the target for value is an array variable.
- The target of an assignment from a FETCH statement, when the corresponding source data is an array value, and the FETCH statement is issued in an SQL PL context.
- The target of a SELECT INTO statement, when source data for the corresponding column of the result table is an array value.
- The target of an assignment for a SET *assignment-statement* statement or an SQL PL *assignment-statement* statement, when the corresponding source value is an array value.
- The target of a VALUES INTO statement, when the source data value is an array value.
- An argument to or from a routine (CALL statement or function invocation).
- The value that is returned in a RETURN statement of an SQL scalar function.
- An ORDER BY or GROUP BY clause of an outer fullselect.
- The source value in a USING clause for an EXECUTE statement or OPEN statement, in an SQL PL context.

An array variable can also be referenced in an array element specification. An element of a user-defined array type can be referenced anywhere that an expression that returns the same data type as an element of that array can be used.

Restriction: An array variable or an array element must not be referenced in an SQL statement, other than a CALL statement, after a connection at a remote server has been established. This restriction includes the case of an SQL statement that is executing at a remote server as a result of a three-part name or an alias that resolves to an object at a remote server.

Related reference

[Array element specification](#)

The array element specification returns the element from an array specified by *array-index*.

Host structures in PL/I, C, and COBOL

A *host structure* is a PL/I structure, C structure, or COBOL group that is referred to in an SQL statement.

Host structures are defined by statements of the host language, as explained in [Overview of programming applications that access Db2 for z/OS data \(Db2 Application programming and SQL\)](#). As used here, the term *host structure* does not include an SQLCA or SQLDA.

In Java and REXX, there is no equivalent to a host structure.

The form of a host structure reference is identical to the form of a host variable reference. The reference :S1:S2 is a host structure reference if S1 names a host structure. If S1 designates a host structure, S2 must be a small integer variable or an array of small integer variables. S1 is the host structure and S2 is its indicator array.

A host structure can be referred to in any context where a list of host variables can be referenced. A host structure reference is equivalent to a reference to each of the host variables contained within the structure in the order which they are defined in the host language structure declaration. The *n*th variable of the indicator array is the indicator variable for the *n*th variable of the host structure.

In PL/I, for example, if *V1*, *V2*, and *V3* are declared as the variables within the structure *S1*, the following two statements are equivalent:

```
EXEC SQL FETCH CURSOR1 INTO :S1;
EXEC SQL FETCH CURSOR1 INTO :V1, :V2, :V3;
```

If the host structure has *m* more variables than the indicator array, the last *m* variables of the host structure do not have indicator variables. If the host structure has *m* fewer variables than the indicator array, the last *m* variables of the indicator array are ignored. These rules also apply if a reference to a host structure includes an indicator variable or a reference to a host variable includes an indicator array. If an indicator array or variable is not specified, no variable of the host structure has an indicator variable.

In addition to structure references, individual host variables or indicator variables in PL/I, C, and COBOL can be referred to by qualified names. The qualified form is a host identifier followed by a period and another host identifier. The first host identifier must name a structure, and the second host identifier must name a host variable at the next level within that structure.

In PL/I, C, and COBOL, the syntax of *host-variable* is:

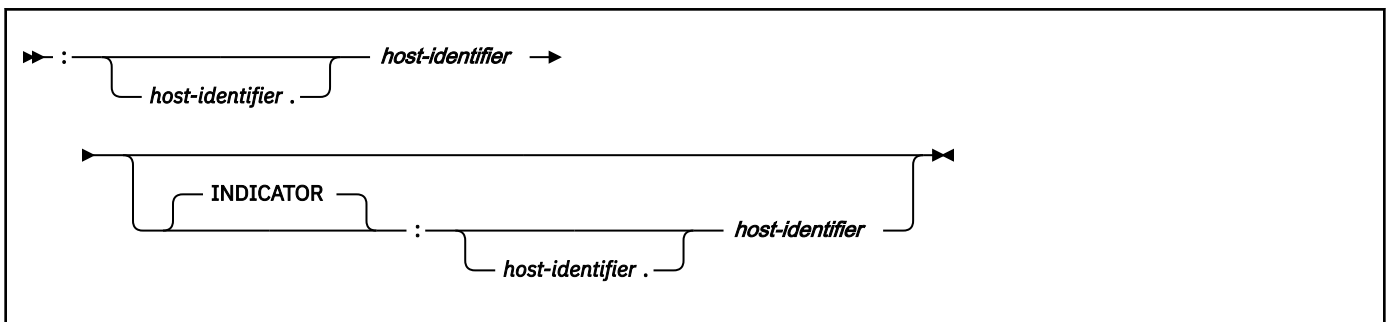

In general, a *host-variable* in an expression must identify a host variable (not a structure) described in the program according to the rules for declaring host variables. However, there are a few SQL statements that allow a host variable in an expression to identify a structure, as specifically noted in the descriptions of the statements.

The following examples show references to host variables and host structures:

```
:V1 :S1.V1 :S1.V1:V2 :S1.V2:S2.V4
```

Host-variable arrays in PL/I, C, C++, and COBOL

A *host-variable array* is an array in which each element of the array contains a value for the same column. The first element in the array corresponds to the first value, the second element in the array corresponds to the second value, and so on.

Host-variable arrays can be referenced only as a simple reference in the following contexts. In syntax diagrams, *host-variable-array* designates a reference to a host-variable array.

- In a FETCH statement for a multiple-row fetch. See [“FETCH statement” on page 1924](#).
- In the FOR *n* ROWS form of the INSERT statement with a host-variable array for the source data. See [“INSERT statement” on page 1996](#).
- In a MERGE statement with multiple rows of source data. See [“MERGE statement” on page 2019](#).
- In an EXECUTE statement to provide a value for a parameter marker in a dynamic FOR *n* ROWS form of the INSERT statement or a MERGE statement. See [“EXECUTE statement” on page 1909](#).

Host-variable arrays are defined by statements of the host language, as explained in the following topics:

- [Host-variable arrays in C and C++ \(Db2 Application programming and SQL\)](#)
- [Host-variable arrays in COBOL \(Db2 Application programming and SQL\)](#)
- [Host-variable arrays in PL/I \(Db2 Application programming and SQL\)](#)

Tip: Host-variable arrays are not supported for assembler, FORTRAN, or REXX programs. However, you can use SQL descriptor areas (SQLDA) to achieve similar results in any host language. For more information see [Defining SQL descriptor areas \(SQLDA\)](#) (Db2 Application programming and SQL).

The form of a host-variable array reference is similar to the form of a host variable reference. The reference `:COL1:COL1IND` is a host-variable array reference if `COL1` designates an array. If `COL1` designates an array, `COL1IND` must be a one dimensional array of small integer host variables. The dimension of the host-variable array must be less than or equal to the dimension of the indicator array. If an indicator array is not specified, no variable of the main host-variable array has an indicator variable.

Syntax

In PL/I, C, C++, and COBOL, a *host-variable-array* reference has the following syntax:

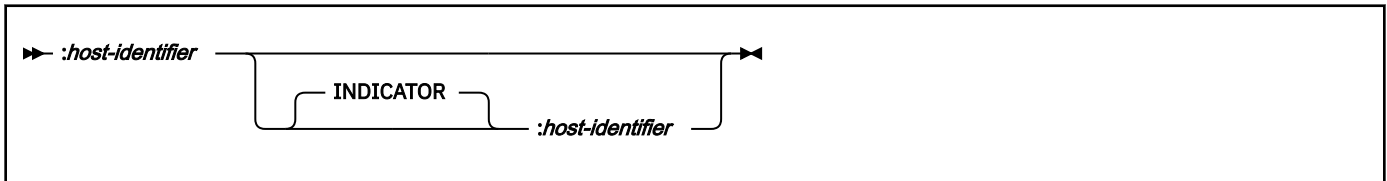

Example

In the following example, `COL1` is the main host-variable array and `COL1IND` is its indicator array. If `COL1` has 10 elements for fetching a single column of data for multiple rows of data, `COL1IND` must also have 10 entries.

```
EXEC SQL FETCH CURSOR FOR 5 ROWS INTO :COL1 :COL1IND;
```

Related concepts

[Using host-variable arrays in SQL statements](#) (Db2 Application programming and SQL)

Functions

A *function* is an operation denoted by a function name followed by zero or more operands that are enclosed in parentheses. It represents a relationship between a set of input values and a set of result values.

The input values to a function are called *arguments*. For example, a function can be passed with two input arguments that have date and time data types and return a value with a timestamp data type as the result.

Types of functions

There are several ways to classify functions. One way to classify functions is as built-in functions, user-defined functions, or cast functions that are generated for distinct types.

Built-in functions

Built-in functions include operator functions such as "+", aggregate functions such as AVG, and scalar functions such as SUBSTR. For a list of the built-in aggregate and scalar functions and information on these functions, see [Chapter 4, "Built-in functions,"](#) on page 341.

The built-in functions are in schema SYSIBM.

The RANK, DENSE_RANK, and ROW_NUMBER specifications are sometimes referred to as built-in functions. Refer to ["OLAP specifications"](#) on page 280 for more information on these specifications.

User-defined functions

User-defined functions are functions that are created using the CREATE FUNCTION statement and registered to the Db2 in the catalog. These functions allow users to extend the function of Db2 by adding their own or third party vendor function definitions.

A user-defined function is an SQL, external, or sourced function. An SQL function is defined to the database using only SQL statements. An *external function* is defined to the database with a reference to an external program that is executed when the function is invoked. A *sourced function* is defined to the database with a reference to a built-in function or another user-defined function. Sourced functions can be used to override built-in aggregate and scalar functions for use on distinct types.

A user-defined function resides in the schema in which it was registered. The schema cannot be SYSIBM.

To help you define and implement user-defined functions, sample user-defined functions are supplied with Db2. You can also use these sample user-defined functions in your application program just as you would any other user-defined function if the appropriate installation job has been run.

For more information, see the following related topics:

- [Appendix O, “Sample user-defined functions,” on page 2941](#)
- [Creating a user-defined function \(Db2 Application programming and SQL\)](#)
- [“CREATE FUNCTION statement \(overview\)” on page 1424](#)

Generated user-defined functions for distinct types

Generated user-defined functions for distinct types (also called *cast functions*) are functions that Db2 automatically generates when a distinct type is created using the CREATE TYPE statement.

Cast functions support casting from the distinct type to the source type and from the source type to the distinct type. The ability to cast between the data types is important because a distinct type is compatible only with itself.

The generated cast functions reside in the same schema as the distinct type for which they were created. The schema cannot be SYSIBM.

For more information, see [“CREATE TYPE statement” on page 1795](#)

Other ways classify functions

Functions can also be classified as aggregate, scalar, or table functions, depending on the input data values and result values.

- An *aggregate function* receives a set of values for each argument (such as the values of a column) and returns a single-value result for the set of input values. Aggregate functions are sometimes called *column functions*. Built-in functions and user-defined sourced functions can be aggregate functions. Aggregate functions cannot be external user-defined function or SQL functions. For more information, see [“Aggregate functions” on page 353](#).
- A *scalar function* receives a single value for each argument and returns a single-value result. Built-in functions and user-defined functions, external, sourced, and SQL, can be scalar functions. The functions that are created for distinct types are also scalar functions. For more information, see [“Scalar functions” on page 382](#).
- A *table function* returns a table for the set of arguments it receives. Each argument is a single value. A table function can only be referenced in the FROM clause of a subselect. A table function can be defined as an external or SQL function, but a table function cannot be a sourced function.

Table functions can be used to apply SQL language processing power to data that is not stored in the database or to allow access to such data as if it were stored in a table. For example, a table function can read a file or get data from the web and return a result table.

For more information, see [“Table functions”](#) on page 669.

For a list of the aggregate, scalar, and table functions and information on these functions, see [Chapter 4, “Built-in functions,”](#) on page 341.

Function invocation

Each reference to a scalar or aggregate function (either built-in or user-defined) conforms to the following syntax:

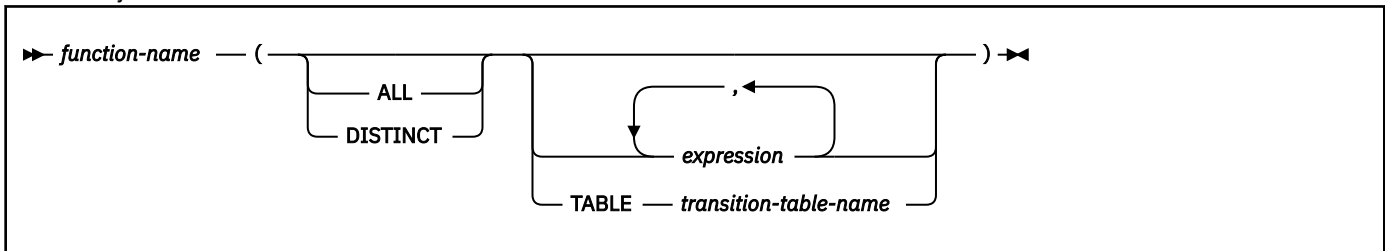

In the above syntax, *expression* cannot include an aggregate function. See [“Expressions”](#) on page 245 for other rules for *expression*.

The `ALL` or `DISTINCT` keyword can only be specified for an aggregate function or a user-defined function that is sourced on an aggregate function.

When a function is invoked within a trigger body, the `TABLE` keyword can be specified to indicate that an argument is a trigger transition table. In this case, the corresponding parameter of the function must have been defined with the `TABLE LIKE` clause.

Table functions can be referenced only in the `FROM` clause of a subselect. For more information on referencing a table function, see the description of the [“from-clause”](#) on page 1017.

An array can only be specified as an argument to a function for a parameter that is defined with an array type. An array element specifies a scalar value, and can therefore be specified as an argument to a function when the data type of the array element is promotable to the data type of the corresponding parameter of the function definition.

When the function is invoked, the value of each of its parameters is assigned using storage assignment, to the corresponding parameter of the function. Control is passed to external functions according to the calling conventions of the host language. When execution of a user-defined aggregate or scalar function is complete, the result of the function is assigned, using storage assignment, to the result data type. For information about assignment rules, see [“Assignment and comparison”](#) on page 143.

Additionally, a character `FOR BIT DATA` argument cannot be passed as input for a parameter that is not defined as character `FOR BIT DATA`. Likewise, a character argument that is not `FOR BIT DATA` cannot be passed as input for a parameter defined as character `FOR BIT DATA`.

For compatibility with other SQL implementations, `UNIQUE` can be specified as a synonym for `DISTINCT` in aggregate functions.

Function resolution

After a function is invoked, Db2 must determine which function to execute. This process is called *function resolution* and it applies to both built-in and user-defined functions.

A function is invoked by its function name, which is implicitly or explicitly qualified with a schema name, followed by parentheses that enclose the arguments to the function. Within the database, each function is uniquely identified by its *function signature*, which is its schema name, function name, the number of parameters, and the data types of the parameters. A schema can contain several functions that have the same name but each of which have a different number of parameters or parameters with different data

types. Also, a function with the same name, number of parameters, and types of parameters can exist in multiple schemas.

Overloading a function

A function name for which there are multiple function instances with the same number of parameters in the same schema is called an *overloaded function*.

Overriding a function

Functions can be *overridden* across the schemas of an SQL path, in which case there is more than one function with the same name and the same number of parameters in different schemas of the SQL path. These functions do not necessarily have different parameter data types.

Function resolution has two steps:

1. Db2 determines the set of candidate functions based on the qualification of the name of the invoked function, the unqualified name of the invoked function, and the number of arguments that are specified.
2. Db2 determines the best fit from the set of candidate functions based on the data types of the arguments of the invoked function as compared with the data types of the parameters of the functions in the set of candidate functions.

Function resolution is similar for functions that are invoked with a qualified or unqualified function name with the exception that for an unqualified name, Db2 needs to search more than one schema.

To improve performance of function resolution and to prevent potential issues as new functions are added, consider invoking user-defined functions by using a fully qualified name, including the schema name.

For a function invocation that passes a transition table, the data type, length, precision, and scale of each column in the transition table must exactly match the data type, length, precision, and scale of each column of the table that is named in the function definition.

The timestamp for the creation of a user-defined function must be older than the timestamp that results from an explicit bind for the plan or package that contains the function invocation. During automatic bind, built-in functions that are introduced in a Db2 release that is later than the Db2 release that is used to explicitly bind the package or plan are not considered for function resolution.

In a CREATE VIEW statement, function resolution occurs at the time the view is created. If another function with the same name is subsequently created, the view is not affected, even if the new function is a better fit than the one that was chosen at the time the view was created.

Qualified function resolution

When a function is invoked with a schema name and a function name, Db2 only searches the specified schema to resolve which function to execute.

Db2 selects candidate functions based on the following criteria:

- The name of the function instance must match the name in the function invocation.
- The number of input parameters in the function instance must match the number of arguments in the function invocation.
- The authorization ID of the statement must have the EXECUTE privilege to the function instance.

If no function meets these criteria, an error is returned. If one or more candidate functions are found in the schema, this set of candidate functions is processed for best fit.

For a function invocation that contains untyped parameter markers, the data types of those parameter markers are considered to match or be promotable to the data types of the parameters in the function instance.

Unqualified function resolution

When a function is invoked without a qualifier, Db2 searches the list of schemas in the SQL path to resolve which function instance to execute. For each schema in the SQL path, Db2 searches the schema for candidate functions based on the following criteria:

- The name of the function instance must match the name in the function invocation.

- The number of input parameters in the function instance must match the number of function arguments in the function invocation.
 - The authorization ID of the statement must have the EXECUTE privilege on the function instance.
- : If Db2 does not find any candidate functions, an error is returned.

If no function meets these criteria, an error is returned. If one or more candidate functions are found in the schema, this set of candidate functions is processed for best fit.

For a function invocation that contains untyped parameter markers, the data types of those parameter markers are considered to match or be promotable to the data types of the parameters in the function instance.

Determining the best fit

More than one function with the same name might exist that is a candidate for execution. In that case, Db2 determines which function is the best fit for the invocation by comparing the data types of the parameters of each function in the set of candidate functions to determine which function satisfies the best fit requirements.

Db2 determines the function, or set of functions, that meet the best fit requirements for the invocation by comparing the argument and parameter data types. The data type of the result of the function or the type of function (aggregate, scalar, or table) under consideration does not enter into the determination of best fit.

When determining whether the data types of the parameters are the same as the arguments:

- Synonyms of data types match. For example, DOUBLE and FLOAT are considered to be the same.
- Attributes of a data type (such as length, precision, scale, CCSID) are ignored. Therefore, CHAR(8) and CHAR(35) are considered to be the same, as are DECIMAL(11,2) and DECIMAL(4,3).
- The character and graphic types are considered to be the same. For example, the following data types are considered to be the same type: CHAR and GRAPHIC, VARCHAR and VARGRAPHIC, and CLOB and DBCLOB. CHAR(13) and GRAPHIC(8) are considered to be the same type.
- For this argument, if one function has a data type that fits the function invocation better than the data types in the other functions, that function is the best fit. The precedence list for the promotion of data types in shows the data types that fit each data type, in best-to-worst order.
- If the data types of the first parameter for all the candidate functions fit the function invocation equally well, Db2 repeats this process for the next argument of the function invocation. Db2 continues this process for each argument until a best fit is found.

A subset of the candidate functions is obtained by considering only those functions for which the data type of each input argument of the function invocation matches or is promotable to the data type of the corresponding parameter of the function instance. The precedence list for the promotion of data types in [“Promotion of data types” on page 129](#) shows the data types that fit (considering promotion) for each data type in best-to-worst order. If this subset is not empty, the best fit is determined using the promotable process on this subset of candidate functions. If this subset is empty, and the original set of candidate functions consisted of a single function, the best fit is determined using the castable process on the original candidate function. Otherwise, an error is returned.

Promotable process

The *promotable process* determines the best fit for function resolution by considering only whether input arguments in the function invocation match or can be promoted to the data type of the corresponding parameter of the function definition.

For the subset of candidate functions, Db2 compares the parameter lists from left to right, using the following process:

- The data type of the argument in the function invocation is compared to the data type of the corresponding parameter in the definition of each candidate function. (synonyms of data types match and attributes of data type are ignored).

- Attributes of a data type (such as length, precision, scale, CCSID) are ignored. Therefore, CHAR(8) and CHAR(35) are considered to be the same, as are DECIMAL(11,2) and DECIMAL(4,3).
- The character and graphic types are considered to be the same. For example, the following data types are considered to be the same type: CHAR and GRAPHIC, VARCHAR and VARGRAPHIC, and CLOB and DBCLOB. CHAR(13) and GRAPHIC(8) are considered to be the same type.
- For this argument, if one candidate function has a data type that fits the function invocation better than the data types in the other candidate functions, that function is the best fit. The precedence list for the promotion of data types in “Promotion of data types” on page 129 shows the data types that fit each data type, in best-to-worst order.
- If the data types of the first parameter for more than one candidate functions fits the function invocation equally well, Db2 repeats this process for the next argument of the function invocation. Db2 continues this process for each argument until a best fit is found.

If only one candidate function remains after comparing all the arguments, that function is the best fit. If more than one candidate function remains, all the remaining candidate functions are considered to be equally the best fit. In this case, Db2 selects the function whose schema is first in the SQL path.

If a function is selected, its successful use depends on it being invoked in a context in which the returned result is allowed. For example, if the function returns a table where a table is not allowed, an error is returned.

Function resolution and input argument casting

In considering the best fit of a candidate function, Db2 determines if the input arguments can be implicitly cast to the data type of the corresponding parameter for function resolution.

The *castable process* determines the best fit of a function, first considering if the input arguments in the function invocation match or can be promoted to the data type of the corresponding parameter of the function definition, and then if the input arguments can be implicitly cast to the data type of the corresponding parameter for function resolution. For the set of candidate functions, Db2 compares the parameter lists from left to right, using the following process:

- The data type of the argument in the function invocation is compared to the data type of the corresponding parameter in the definition of the candidate function to ensure that each argument can be promoted or cast to the corresponding parameter. If not, an error is returned.

If a function is selected, its successful use depends on it being invoked in a context in which the returned result is allowed. For example, if the function returns a table where a table is not allowed, an error is returned.

Implicit casting for function resolution: Implicit casting for function resolution is not supported for arguments with a user-defined type, binary, ROWID, or XML data type. It is also not supported for built-in or user-defined cast functions. Implicit casting is supported for the following cases:

- A numeric data type can be cast to a value of another numeric data type that is not in the data type promotion list for the source data type. This includes casting a numeric value to a numeric data type that is lower in the promotion list.
- A numeric data type can be cast to a character or graphic string data type, except for a LOB.
- A character or graphic string data type, except for a LOB, can be cast to a numeric data type.
- A character or graphic string data type, except for a LOB, can be cast to a date, time, or timestamp data type.
- A varying length character string data type, except for a LOB, can be cast to a fixed length character data type.

Best-fit consideration

After determining the function that is the best fit, use of the function still might not be permitted. Each function is defined to return a result with a specific data type. If this result data type is not compatible with the context in which the function is invoked, an error occurs.

For example, assume functions named STEP are defined with different data types:

```
STEP(SMALLINT) returns CHAR(5)
STEP(DOUBLE) returns INTEGER
```

Assume also that the function is invoked with the following function reference (where S is a SMALLINT column):

```
SELECT ... 3+STEP(S) ...
```

Because there is an exact match on argument type, the first STEP is chosen. An error occurs on the statement because the result type is CHAR(5) instead of a numeric type as required for an argument of the addition operator.

In cases where the arguments of the function invocation are not an exact match to the data types of the parameters of the selected function, the arguments are converted to the data type of the parameter at execution using the same rules as assignment to columns. See [“Assignment and comparison”](#) on page 143. Problems with conversions can also occur when precision, scale, length, or the encoding scheme differs between the argument and the parameter. Conversion might occur for a character string argument when the corresponding parameter of the function has a different encoding scheme or CCSID. For example, an error occurs on function invocation when mixed data that actually contains DBCS characters is specified as an argument and the corresponding parameter of the function is declared with an SBCS subtype.

Additionally, a character FOR BIT DATA argument cannot be passed as input for a parameter that is not defined as character FOR BIT DATA. Likewise, a character argument that is not FOR BIT DATA cannot be passed as input for a parameter that is defined as character FOR BIT DATA.

An error also occurs in the following examples:

- The function is referenced in a FROM clause, but the function selected by the function resolution step is a scalar or aggregate function.
- The function calls for a scalar or aggregate function, but the function selected by the resolution step is a table function.

SQL path considerations for built-in functions

Function resolution applies to all functions, including built-in functions and other functions provided by Db2. If a function is invoked without its schema name, the SQL path is searched.

With the exception of the Db2 IBM MQ functions, the built-in functions are in schemas SYSIBM or SYSIBMADM.

Additional functions are available in other schemas, but are not considered as built-in functions because they are developed as user-defined functions that have no special processing considerations.

If SYSIBM is not first in the path, it is possible that Db2 will select another function instead of the intended built-in function. If schema "SYSIBM", "SYSFUN", "SYSPROC", "SYSIBMADM" is not explicitly specified in the SQL path, the schema is implicitly assumed at the front of the path. Db2 adds implicitly assumed schemas in the order of "SYSIBM", "SYSFUN", "SYSPROC", "SYSIBMADM".

Related concepts

SQL path

The *SQL path* is an ordered list of schema names. Db2 uses the path to resolve the schema name for certain unqualified object names that appear in any context other than as the main object of an ALTER, CREATE, DROP, COMMENT, GRANT, RENAME, or REVOKE statement.

Version resolution

Normally, the currently active version of an SQL function is used for invocation of the function.

However, if the invocation is a recursive invocation that occurs inside the body of the same function, and the currently active version has changed since the original invocation, the active version is not used. The version that is used in the original invocation is used for any recursive invocation until the entire function completes. This preserves the semantics of the version that is used by the original invocation.

The version used in the original invocation is also used when the recursive invocation is indirect. For example, assume that function FN1 invokes function FN2, which in turn invokes FN1 (indirect, recursive invocation). The invocation of function FN1 in function FN2 uses the version of FN1 that is active at the time of the original invocation of function FN1.

Since the currently active version is used at the next invocation (except in recursive invocations), it is possible that two or more versions of the same function can be run by a given thread. For example, an invocation of function FN1 in an application causes the currently active version of FN1 to load and execute. During or after execution of the original invocation of FN1, an ALTER FUNCTION statement that specifies ACTIVE VERSION FN1_V2 is run and changes the active version of the function FN1 to version FN1_V2. Subsequent invocations of function FN1 from the same thread will load and execute the currently active version of the function, FN1_V2.

Examples of function resolution

The following examples illustrate function resolution.

Example 1: Assume that MYSCHEMA contains two functions, both named FUNA, that were registered with these partial CREATE FUNCTION statements.

1. CREATE FUNCTION MYSCHEMA.FUNA (VARCHAR(10), INT, DOUBLE) ...
2. CREATE FUNCTION MYSCHEMA.FUNA (VARCHAR(10), REAL, DOUBLE) ...

Also assume that a function with three arguments of data types VARCHAR(10), SMALLINT, and DECIMAL is invoked with a qualified name:

```
MYSCHEMA.FUNA(VARCHARCOL, SMALLINTCOL, DECIMALCOL)
```

Both MYSCHEMA.FUNA functions are candidates for this function invocation because they meet the criteria specified in “Function resolution” on page 239. The data types of the first parameter for the two function instances in the schema, which are both VARCHAR, fit the data type of the first argument of the function invocation, which is VARCHAR, equally well. However, for the second parameter, the data type of the first function (INT) fits the data type of the second argument (SMALLINT) better than the data type of second function (REAL). Therefore, Db2 selects the first MYSCHEMA.FUNA function as the function instance to execute.

Example 2: Assume that these functions were registered with these partial CREATE FUNCTION statements:

1. CREATE FUNCTION SMITH.ADDIT (CHAR(5), INT, DOUBLE) ...
2. CREATE FUNCTION SMITH.ADDIT (INT, INT, DOUBLE) ...
3. CREATE FUNCTION SMITH.ADDIT (INT, INT, DOUBLE, INT) ...
4. CREATE FUNCTION JOHNSON.ADDIT (INT, DOUBLE, DOUBLE) ...
5. CREATE FUNCTION JOHNSON.ADDIT (INT, INT, DOUBLE) ...
6. CREATE FUNCTION TODD.ADDIT (REAL) ...
7. CREATE FUNCTION TAYLOR.SUBIT (INT, INT, DECIMAL) ...

Also assume that the SQL path at the time an application invokes a function is "TAYLOR" "JOHNSON", "SMITH". The function is invoked with three data types (INT, INT, DECIMAL) as follows:

```
SELECT ... ADDIT(INTCOL1, INTCOL2, DECIMALCOL) ...
```

Function 5 is chosen as the function instance to execute based on the following evaluation:

- Function 6 is eliminated as a candidate because schema TODD is not in the SQL path.
- Function 7 in schema TAYLOR is eliminated as a candidate because it does not have the correct function name.
- Function 1 in schema SMITH is eliminated as a candidate because the INT data type is not promotable to the CHAR data type of the first parameter of Function 1.
- Function 3 in schema SMITH is eliminated as a candidate because it has the wrong number of parameters.

- Function 2 is a candidate because the data types of its parameters match or are promotable to the data types of the arguments.
- Both Function 4 and 5 in schema JOHNSON are candidates because the data types of their parameters match or are promotable to the data types of the arguments. However, Function 5 is chosen as the better candidate because although the data types of the first parameter of both functions (INT) match the first argument (INT), the data type of the second parameter of Function 5 (INT) is a better match of the second argument (INT) than Function 4 (DOUBLE).
- Of the remaining candidates, Function 2 and 5, Db2 selects Function 5 because schema JOHNSON comes before schema SMITH in the SQL path.

Expressions

An *expression* specifies a value and can take a number of different forms, such as a simple value, consisting of only a constant or a column name, or it can be more complex with operators, other expressions, and more.

Authorization

The use of some of the expressions, such as a *scalar-fullselect*, *sequence-reference*, *global-variable*, or *function-invocation*, requires having the appropriate authorization. For these objects, the privilege set that is defined below must include the following authorization:

- *cast-specification*. The authorization to reference a user-defined type in a cast specification. For information about authorization considerations, see [“CAST specification” on page 267](#).
- *function-invocation*. Authorization to execute the function. For information about how the particular function is chosen and authorization considerations, see [“Function resolution” on page 239](#).
- *scalar-fullselect*. For information about authorization considerations, see [“Authorization for queries” on page 1007](#).
- *sequence-reference*. The USAGE privilege on the specified sequence, ownership of the sequence, DATAACCESS authority, or SYSADM authority. For example, with a sequence reference, USAGE authorization on the sequence is required.
- *global-variable*. The READ privilege on the specified global variable, ownership of the global variable, DATAACCESS authority, or SYSADM authority.

Privilege set: If the statement is embedded in an application program, the privilege set is the privileges that are held by the owner of the plan or package. If the statement is dynamically prepared, the privilege set is the union of the privilege sets that are held by each authorization ID of the process.

Syntax

The form of an expression is as follows:

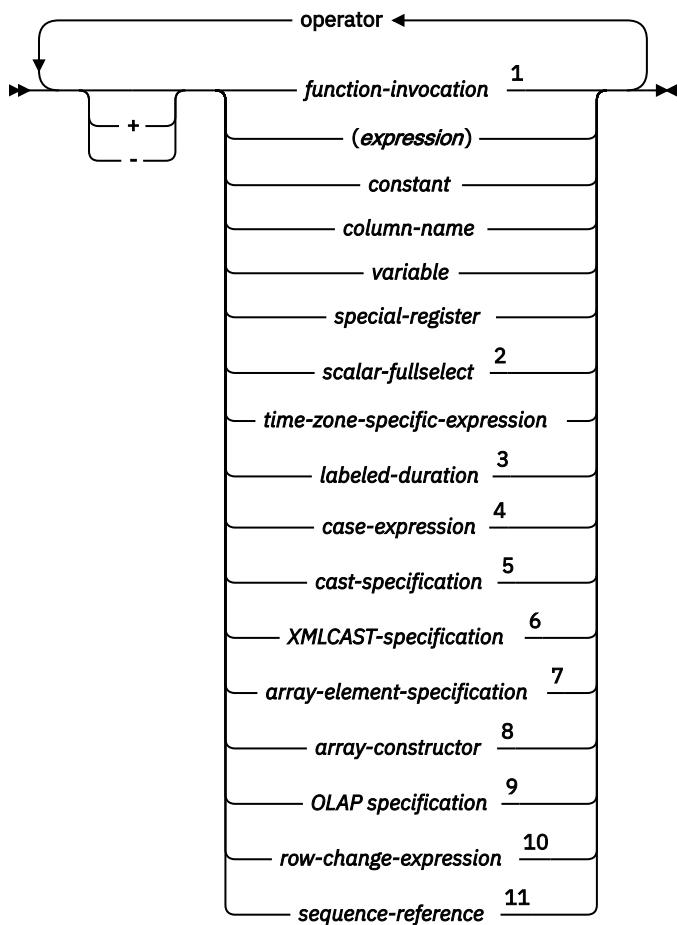

Notes:

- ¹ Must be a scalar function. See “Functions” on page 237 for more information.
- ² See “Scalar-fullselect” on page 256 for more information.
- ³ See Labeled durations for more information.
- ⁴ See “CASE expressions” on page 264 for more information.
- ⁵ See “CAST specification” on page 267 for more information.
- ⁶ See “XMLCAST specification” on page 277 for more information.
- ⁷ See “Array element specification” on page 278 for more information.
- ⁸ See “Array constructor” on page 279 for more information.
- ⁹ See “OLAP specifications” on page 280
- ¹⁰ See “ROW CHANGE expression” on page 291
- ¹¹ See “Sequence reference” on page 292

operator:

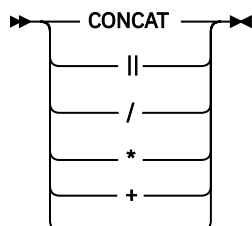

labeled-duration:

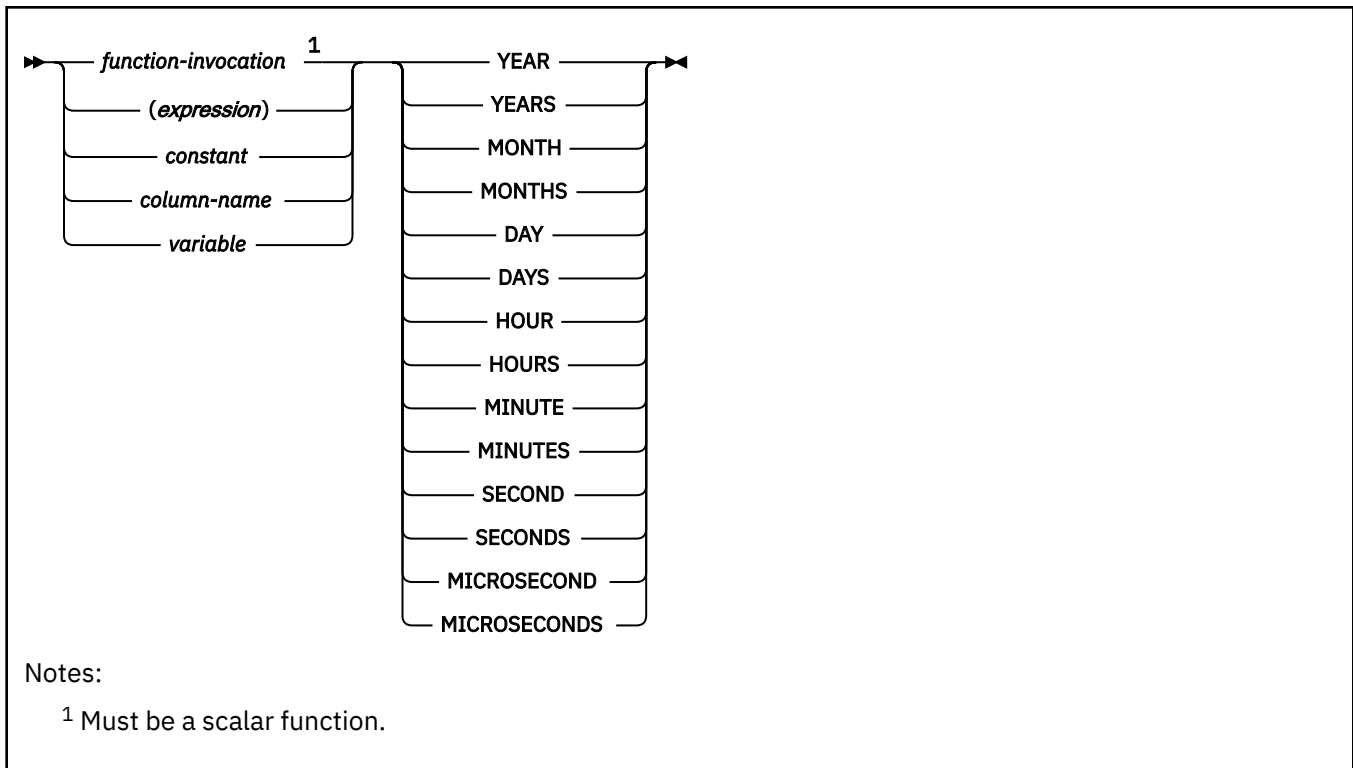

Expressions without operators

If no operators are used, the result of the expression is the specified value. Each of the following examples is an expression that specifies a value based on a column named SALARY:

```
SALARY      :SALARY      'SALARY'      MAX(SALARY)
```

Related concepts

[Characters and tokens in SQL](#)

The most basic elements of SQL syntax are characters and tokens. Tokens are the basic syntactical units of the SQL language.

Concatenation operators in expressions

When two strings operands are concatenated, the result of the expression is a string.

Introductory concepts

[String data types \(Introduction to Db2 for z/OS\)](#)

[Concatenation of strings \(Introduction to Db2 for z/OS\)](#)

The operands of concatenation must be compatible strings. A binary string cannot be concatenated with a character string, including character strings that are defined as FOR BIT DATA (for more information on

¹³ In various EBCDIC code pages, Db2 supports code point combinations X'4F4F', X'BBBB', and X'5A5A' to mean concatenation. X'BBBB' and X'5A5A' are interpreted to mean concatenation only on single byte character set Db2 subsystems. X'BBBB' is a pair of right brackets characters (']']) in some EBCDIC code pages and is not used as a concatenation operator when it appears in an array-index expression. Consider using CONCAT as a concatenation operator instead of X'BBBB' because X'BBBB' might be confused with right brackets in an array-index expression.

the compatibility of data types, see the compatibility matrix in [Table 30 on page 144](#)). A distinct type that is based on a string type can be concatenated only if an appropriate user-defined function is created.

Both CONCAT and the vertical bars (||) represent the concatenation operator. Vertical bars (or the characters that must be used in place of vertical bars in some countries¹³) can cause parsing errors in statements passed from one DBMS to another. The problem occurs if the statement undergoes character conversion with certain combinations of source and target CCSIDs¹³. Thus, CONCAT is the preferable concatenation operator.

If either operand can be null, the result can be null, and if either is null, the result is the null value. Otherwise, the result consists of the first operand string followed by the second.

The following table shows how the string operands determine the data type and the length attribute of the result (the order in which the operands are concatenated has no effect on the result).

Table 49. Data type and length of concatenated operands

If one operand column is	And the other operand is	The data type of the result column is¹
CHAR(x)	CHAR(y) with a combined length attribute that is less than 256	CHAR(x+y) ²
	CHAR(y) with a combined length attribute that is greater than 255	VARCHAR(MIN(x'+y',32764)) ³
	VARCHAR(y)	
VARCHAR(x)	VARCHAR(y)	VARCHAR(MIN(x'+y',32764)) ³
CLOB(x)	CHAR(y)	CLOB(MIN(x'+y',2G))
	VARCHAR(y)	
	CLOB(y)	
	GRAPHIC(y)	DBCLOB(MIN(x+y,1G))
	VARGRAPHIC(y)	
GRAPHIC(x)	CHAR(y)	VARGRAPHIC(MIN(x+y,16382)) ⁴
	VARCHAR(y)	
	VARGRAPHIC(y)	
VARGRAPHIC(x)	CHAR(y)	VARGRAPHIC(MIN(x+y,16382)) ⁴
	VARCHAR(y)	
	GRAPHIC(y)	
	GRAPHIC(y)	

Table 49. Data type and length of concatenated operands (continued)

If one operand column is	And the other operand is	The data type of the result column is ¹
DBCLOB(x)	CHAR(y)	DBCLOB(MIN(x+y,1G))
	VARCHAR(y)	
	CLOB(y)	
	GRAPHIC(y)	
	VARGRAPHIC(y)	
	DBCLOB(y)	
BINARY(x)	BINARY(y) with a combined length attribute that is less than 256	BINARY(x+y)
	BINARY(y) with a combined length attribute that is greater than 255	VARBINARY(MIN(x+y,32764))
VARBINARY(x)	VARBINARY(y)	VARBINARY(MIN(x+y,32764))
	BINARY(y)	
BLOB(x)	BLOB(y)	BLOB(MIN(x+y, 2G))

Notes:

- 2G represents 2,147,483,647 bytes
 - 1G represents 1,073,741,823 double-byte characters
- Neither CHAR(x) nor CHAR(y) can contain mixed data. If either operand contains mixed data, the result is VARCHAR(MIN(x'+y',32764)).
- If conversion of the first operand is required, x' = 3x; otherwise, it remains x. If conversion of the second operand is required, y' = 3y; otherwise, it remains y.
- Both operands are converted to UTF-16, if necessary (that is, the operand is not already UTF-16), and the results are concatenated.

As the previous table shows, the length of the result is the sum of the lengths of the operands. However, the length of the result is two bytes less if redundant shift code characters are eliminated from the result. Redundant shift code characters exist when both character strings are EBCDIC mixed data, and the first string ends with a "shift-in" character (X'0F') and the second operand begins with a "shift-out" character (X'0E'). These two shift code characters are removed from the result.

The CCSID of the result is determined by the rules set forth in [“Character conversion in set operations and concatenations” on page 1066](#). Some consequences of those rules are the following:

- If either operand is BIT data, the result is BIT data.
- The conversion that occurs when SBCS data is compared with mixed data depends on the encoding scheme. If the encoding scheme is Unicode, the SBCS operand is converted to MIXED. Otherwise, the conversion depends on the field MIXED DATA on installation panel DSNTIPF for the Db2 that does the comparison:
 - Mixed data if the MIXED DATA option at the server is YES. The result is not necessarily well-formed mixed data.
 - SBCS data if the MIXED DATA option at the server is NO. If the mixed data cannot be converted to pure SBCS data, an error occurs.

If an operand is a string from a column with a field procedure, the operation applies to the decoded form of the value. The result does not inherit the field procedure.

One operand of concatenation can be a parameter marker. When one operand is a parameter marker, its data type and length attributes are considered to be the same as those for the operand that is not a parameter marker except for a string data type. Refer to [Table 49 on page 248](#) for the formula used to calculate data type length for untyped parameter markers in the CONCAT operator when another operand is a string data type. The order of concatenation operations must be considered to determine these attributes in the case of nested concatenation.

No operand of concatenation can be a distinct type even if the distinct type is based on a character data type. To concatenate a distinct type, create a user-defined function that is sourced on the CONCAT operator. For example, if distinct types TITLE and TITLE_DESCRIPTION were both based on data type VARCHAR(25), the following user-defined function, named ATTACH, could be used to concatenate the two distinct types:

```
CREATE FUNCTION ATTACH (TITLE, TITLE_DESCRIPTION)
  RETURNS VARCHAR(50) SOURCE CONCAT (VARCHAR(), VARCHAR())
```

Alternatively, the concatenation operator could be overloaded by using a user-defined function to add the distinct types:

```
CREATE FUNCTION "||" (TITLE, TITLE_DESCRIPTION)
  RETURNS VARCHAR(50) SOURCE CONCAT (VARCHAR(), VARCHAR())
```

Related reference

[CONCAT scalar function](#)

The CONCAT function combines two compatible string arguments.

Arithmetic operators in expressions

If arithmetic operators are used, the result of the expression is a number derived from the application of the operators to the values of the operands.

The result of the expression can be null. If any operand has the null value, the result of the expression is the null value. Arithmetic operators (except unary plus, which is meaningless) must not be applied to strings. For example, USER+2 is invalid. Multiplication and division operators must not be applied to datetime values, which can only be added and subtracted.

The prefix operator + (*unary plus*) does not change its operand. The prefix operator - (*unary minus*) reverses the sign of a nonzero, non-decimal floating-point operand. The prefix operator - (*unary minus*) reverses the sign of all decimal floating-point operands, including zero and special values; that is, signaling and non-signaling NaNs and plus and minus infinity. If the data type of *A* is *small integer*, the data type of *-A* is *large integer*. The first character of the token following a prefix operator must not be a plus or minus sign.

The *infix operators* specify addition (+), subtraction (-), multiplication (*), and division (/). The value of the second operand of division must not be zero.

Arithmetic with two integer operands

If both operands of an arithmetic operator are integers, the operation is performed in binary. The result is a large integer unless either (or both) operand is a big integer, in which case the result is a big integer.

The result of an integer arithmetic operation (including unary minus) must be within the range of the result type.

Arithmetic with an integer and a decimal operand

If one operand is an integer and the other operand is decimal, the operation is performed in decimal. The arithmetic operation uses a temporary copy of the integer that has been converted to a decimal number.

The temporary copy of the integer that has been converted to a decimal number has a precision p and scale 0. p is 19 for a big integer, 11 for a large integer, and 5 for a small integer. In the case of an integer constant, p depends on the number of digits in the integer constant. p is 5 for an integer constant consisting of 5 digits or fewer. Otherwise, p is the same as the number of digits in the integer constant.

Arithmetic with an integer and a decimal floating-point operand

If one operand is a small integer, large integer, or big integer and the other is a decimal floating-point number, the operation is performed in decimal floating point. The arithmetic operation uses a temporary copy of the integer that has been converted to a decimal floating-point number.

For small integer or large integer, the temporary copy of the integer is converted to DECFLOAT(16). For big integer, the temporary copy of the big integer is converted to DECFLOAT(34). The rules for two decimal floating point operands are then applied.

Arithmetic with two decimal operands

If both operands are decimal, the operation is performed in decimal.

The result of any decimal arithmetic operation is a decimal number with a precision and scale that depend on two factors:

The precision and scale of the operands

In the discussion of operations with two decimal operands, the precision and scale of the first operand are denoted by p and s , that of the second operand by p' and s' . Thus, for a division, the dividend has precision p and scale s , and the divisor has precision p' and scale s' .

Whether DEC31 or DEC15 is in effect for the operation

DEC31 and DEC15 specify the rules to be used when both operands in a decimal operation have precisions of 15 or less. DEC15 specifies the rules which do not allow a precision greater than 15 digits, and DEC31 specifies the rules which allow a precision of up to 31 digits. The rules for DEC31 are always used if either operand has a precision greater than 15.

For static SQL statements, the value of the field DECIMAL ARITHMETIC on installation panel DSNTIP4 or the SQL processing option DEC determines whether DEC15 or DEC31 is used.

For dynamic SQL statements, the value of the field DECIMAL ARITHMETIC on installation panel DSNTIP4, the SQL processing option DEC, or the special register CURRENT PRECISION determines whether DEC15 or DEC31 is used according to these rules:

- Field DECIMAL ARITHMETIC applies if either of these conditions is true:
 - DYNAMICRULES run behavior applies and the application has not set CURRENT PRECISION.
For a list of the DYNAMICRULES option values that specify run, bind, define, or invoke behavior, see [Table 14 on page 94](#).
 - DYNAMICRULES bind, define, or invoke behavior applies; the value of installation panel field USE FOR DYNAMICRULES is YES; and the application has not set CURRENT PRECISION.
- SQL processing option DEC applies if DYNAMICRULES bind, define, or invoke behavior is in effect, the value of installation panel field USE FOR DYNAMICRULES is NO, and the application has not set CURRENT PRECISION.
- Special register CURRENT PRECISION applies if the application sets the register.

The value of DECIMAL ARITHMETIC is the default value for the SQL processing option and the special register. SQL statements executed using SPUFI use the value in DECIMAL ARITHMETIC.

Decimal addition and subtraction

For decimal operations, the precision and scale of the result depends on the precision and scale of the operands.

If the operation is addition or subtraction and the operands do not have the same scale, the operation is performed with a temporary copy of one of the operands that has been extended with trailing zeros so that its fractional part has the same number of digits as the other operand.

The precision of the result is the minimum of n and the quantity $\text{MAX}(p-s, p'-s')+ \text{MAX}(s, s')+1$. The scale is $\text{MAX}(s, s')$. n is 31 if DEC31 is in effect or if the precision of at least one operand is greater than 15. Otherwise, n is 15.

In COBOL, blanks must precede and follow a minus sign to avoid any ambiguity with COBOL host variable names (which allow the use of a dash).

Decimal multiplication

For decimal multiplication, the precision and scale of the result depends on the precision and scale of the operands.

For multiplication, the precision of the result is $\text{MIN}(n, p+p')$, and the scale is $\text{MIN}(n, s+s')$. n is 31 if DEC31 is in effect or if the precision of at least one operand is greater than 15. Otherwise, n is 15.

If both operands have a precision greater than 15, the operation is performed using a temporary copy of the operand with the smaller precision. If the operands have the same precision, the second operand is selected. If more than 15 significant digits are needed for the integral part of the copy, the statement's execution is ended and an error occurs. Otherwise, the copy is converted to a number with precision 15, by truncating the copy on the right. The truncated copy has a scale of $\text{MAX}(0, S-(P-15))$, where P and S are the original precision and scale. If, in the process of truncation, one or more nonzero digits are removed, SQLWARN7 in SQLCA is set to W, indicating loss of precision.

When both operands have a precision greater than 15, the foregoing formulas for the precision and scale of the result still apply, with one change: for the operand selected as the copy, use the precision and scale of the truncated copy; that is, use 15 as the precision and $\text{MAX}(0, S-(P-15))$ for the scale.

Let n denote the value of the operand with the greater precision or the first operand in the case of operands with the same precision. The number of leading zeros in a 31-digit representation of n must be greater than the precision of the other operand. This is always the case if the precision of the operand is 15 or less. With greater precisions, overflow can occur even if the precision of the result is less than 31. For example, the expression:

```
100000000000000000000000000000000. * 1
```

will cause overflow because the number of leading zeros in the 31-digit representation of the large number and the precision of the small number are both 5. See [“Arithmetic with an integer and a decimal operand”](#) on page 250.

Arithmetic with an integer and a decimal operand

If one operand is an integer and the other operand is decimal, the operation is performed in decimal. The arithmetic operation uses a temporary copy of the integer that has been converted to a decimal number.

The temporary copy of the integer that has been converted to a decimal number has a precision p and scale 0. p is 19 for a big integer, 11 for a large integer, and 5 for a small integer. In the case of an integer constant, p depends on the number of digits in the integer constant. p is 5 for an integer constant consisting of 5 digits or fewer. Otherwise, p is the same as the number of digits in the integer constant.

Decimal division

The rules for a specific decimal division depend on whether the DEC31 option is in effect for the operation, whether p is greater than 15, and whether p' is greater than 15.

The following table shows how the precision and scale of the result depend on these factors. In that table, the occurrence of "N/A" in a row implies that the indicated factor is not relevant to the case represented by the row.

Table 50. Precision (p) and scale (s) of the result of a decimal division

DEC31	p	p'	P	S
Not in effect	≤ 15	≤ 15	15	$15 - (p - s + s')$
In effect	≤ 15	≤ 15	31	$N - (p - s + s')$, where N is $30 - p'$ if p' is odd. N is $29 - p'$ if p' is even.
N/A	> 15	≤ 15	31	$N - (p - s + s')$, where N is $30 - p'$ if p' is odd. N is $29 - p'$ if p' is even.
N/A	N/A	> 15	31	$15 - (p - s + x)$, where x is $\text{MAX}(0, s' - (p' - 15))$ (See the following note)

If p' is greater than 15, the division is performed using a temporary copy of the divisor. If more than 15 significant digits are needed for the integral part of the divisor, the statement's execution is ended, and an error occurs. Otherwise, the copy is converted to a number with precision 15, by truncating the copy on the right. The truncated copy has a scale of $\text{MAX}(0, s' - (p' - 15))$, which is the formula for x . If, in the process of truncation, one or more nonzero digits are removed, SQLWARN7 in SQLCA is set to W, indicating loss of precision.

Minimum divide result scale

If the calculated value of 's' is negative, an error occurs. If a minimum divide result scale is specified, this error does not occur.

The minimum scale is determined according to the following precedence:

Static SQL

1. The precompiler DEC option, if it is set with a non-zero scale.
2. The DECARTH subsystem parameter, if set with a non-zero scale.
3. The MINDVSCL subsystem parameter, if set to value other than NONE.
4. The DECDIV3 subsystem parameter, if set to YES.

Dynamic SQL

1. The CURRENT PRECISION special register, if it is set with a non-zero scale.
2. Either of the following cases:
 - For a package that was bound with DYNAMICRULES RUN or if the DYNRULS DECP value is set to YES: The DECARTH subsystem parameter, if it is set with a non-zero scale.
 - For all other cases: The precompiler DEC option, if it is set with a non-zero scale.
3. The MINDVSCL subsystem parameter, if set to value other than NONE.
4. The DECDIV3 subsystem parameter, if set to YES.

SQL statements that are executed using SPUFI

The DECARTH subsystem parameter value.

The default value for both the precompiler DEC option and the CURRENT PRECISION special register is DECIMAL ARITHMETIC.

A minimum divide result scale of 3 can be specified using the DECDIV3 subsystem parameter setting. A minimum divide scale result in the range 1–9 can be specified using the DECARTH subsystem parameter value of the form 'Dpp.s' where 'pp' is 15 or 31 and represents the precision and 's' represents the minimum divide scale, as a number in the range 1–9. Such a specification overrides

the DEC DIV3 subsystem parameter. When a minimum divide result scale is specified, the formula $\text{MAX}(s, s')$, where s represents the scale derived from the above table and s' represents the value specified by the minimum divide result scale, is applied and a new scale is derived. The newly derived scale is the scale of the result and overrides any scale derived using the table above.

For more information, see:

- [DECIMAL ARITHMETIC field \(DECARTH DECP value\) \(Db2 Installation and Migration\)](#)
- [MINIMUM DIVIDE SCALE field \(DEC DIV3 subsystem parameter\) \(Db2 Installation and Migration\)](#)
- [MINDVSCL subsystem parameter in DSN6SPRM \(Db2 Installation and Migration\)](#)
- [USE FOR DYNAMICRULES field \(DYNRULS DECP value\) \(Db2 Installation and Migration\)](#)
- [SQL processing options \(see "DEC\(15|31\)"\)](#)

Arithmetic with floating-point operands

If either operand of an arithmetic operator is floating-point, the operation is performed in floating-point. If necessary, the operands are first converted to double-precision floating-point numbers. Thus, if any element of an expression is a floating-point number, the result of the expression is a double-precision floating-point number.

An operation involving a floating-point number and an integer is performed with a temporary copy of the integer that has been converted to double-precision floating-point. An operation involving a floating-point number and a decimal number is performed with a temporary copy of the decimal number that has been converted to double-precision floating-point. The result of a floating-point operation must be within the range of floating-point numbers.

The order in which floating-point operands (or arguments to functions) are processed can affect the results slightly because floating-point operands are approximate representations of real numbers. Because the order in which operands are processed might be implicitly modified by Db2 (for example, Db2 might decide what degree of parallelism to use and what access plan to use), an application that uses floating-point operands should not depend on the results being precisely the same each time an SQL statement is executed.

Arithmetic with a floating-point and a decimal floating-point operand

If one operand is a floating-point number (real or double) and the other is a decimal floating-point number, the operation is performed in decimal floating-point. The arithmetic operation uses a temporary copy of the floating-point number that has been converted to a decimal floating-point number.

Arithmetic with two decimal floating-point operands

If both operands are decimal floating point, the operation is performed in decimal floating point. If one operand is DEC FLOAT(n) and the other is DEC FLOAT(m), the operation is performed in DEC FLOAT($\text{max}(n,m)$).

General arithmetic operation rules for DEC FLOAT

The following general rules apply to all arithmetic operations on the DEC FLOAT data type:

- Every operation on finite numbers is carried out as though an exact mathematical result is computed, using integer arithmetic on the coefficient where possible.

If the coefficient of the theoretical exact result has no more than the number of digits that reflect its precision (16 or 34), it is used for the result without change (unless there is an underflow or overflow condition). If the coefficient has more than the number of digits that reflect its precision, it is rounded to exactly the number of digits that reflect its precision (16 or 34), and the exponent is increased by the number of digits that are removed.

For static SQL statements other than CREATE VIEW, the ROUNDING bind option or the native SQL procedure option determines the rounding mode.

For dynamic SQL statements (and static CREATE VIEW statements), the special register CURRENT DECFLOAT ROUNDING MODE determines the rounding mode.

If the value of the adjusted exponent of the result is less than E_{\min} , an exception condition is returned. In this case, the calculated coefficient and exponent form the result, unless the value of the exponent is less than E_{tiny} , in which case the exponent is set to E_{tiny} , the coefficient is rounded (possibly to zero) to match the adjustment of the exponent, and the sign is unchanged. If this rounding gives an inexact result, an underflow exception condition is returned.

If the value of the adjusted exponent of the result is larger than E_{\max} , an overflow exception condition is returned. In this case, the result is as defined as an overflow exception condition and might be infinite. It will have the same sign as the theoretical result.

- Arithmetic that uses the special value infinity follows the usual rules, where negative infinity is less than every finite number and positive infinity is greater than every finite number.

Under these rules, an infinite result is always exact. Certain uses of infinity return an invalid operation condition. The following list is a list of operations that can cause an invalid operation condition and the result of the operation is NaN when one of the operands is infinity but the other operand is not NaN nor sNaN.

- Add +infinity to -infinity during an addition or subtraction operation
- Multiply 0 by +infinity or -infinity
- Divide either +infinity or -infinity by either +infinity or -infinity
- The first argument to the MOD function is either +infinity or -infinity
- Either argument of the QUANTIZE function is +infinity or -infinity
- The second argument of the POWER[®] function is +infinity or -infinity
- A NaN when used as an operand to an arithmetic operation

The following arithmetic rules apply to arithmetic operations and the NaN value:

- The result of any arithmetic operation that has an operand that is a NaN (a quiet NaN or signaling NaN) is NaN. The sign of the result is copied from the first operand that is a signaling NaN, or if neither operand is signaling, the sign is copied from the first operand that is a NaN. Whenever a result is a NaN, the sign of the result depends only on the copied operand.
- The sign of the result of a multiplication or division will be negative only if the operands have different signs and neither is a NaN.
- The sign of the result of an addition or subtraction will be negative only if the result is less than zero and neither operand is a NaN, except for the following cases where the result is a negative 0:
 - A result is rounded to zero, and the value, before rounding, had a negative sign
 - Subtract 0 from -0
 - Addition of operands with opposite signs (or subtraction of operands with the same sign), the result has a coefficient of 0, and the rounding mode is ROUND_FLOOR
 - Multiplication or division and the result has a coefficient of 0 and the signs of the operands are different
 - The first argument of the POWER function is -0, and the second argument is a positive odd number
 - The argument of the CEIL, FLOOR, or SQRT function is -0
 - The first argument of the ROUND or TRUNCATE function is -0

Examples involving special DECFLOAT values:

```

INFINITY + 1           = INFINITY
INFINITY + INFINITY   = INFINITY
INFINITY + -INFINITY  = NAN      -- exception
NAN + 1               = NAN
NAN + INFINITY        = NAN
1 - INFINITY          = -INFINITY
INFINITY - INFINITY   = NAN      -- exception
-INFINITY - -INFINITY = NAN      -- exception
  
```

```

-0.0 - 0.0E1           = -0.0
-1.0 * 0.0E1          = -0.0
1.0E1 / 0              = INFINITY
-1.0E5 / 0.0          = -INFINITY
1.0E5 / -0             = -INFINITY
INFINITY / -INFINITY   = NAN           -- exception
INFINITY / 0           = INFINITY
-INFINITY / 0          = -INFINITY
-INFINITY / -0         = INFINITY

```

Arithmetic with distinct type operands

A distinct type cannot be used with arithmetic operators even if its source data type is numeric. To perform an arithmetic operation, create a function with the arithmetic operator as its source. For example, if there were distinct types INCOME and EXPENSES, both of which had DECIMAL(8,2) data types, the following user-defined function, REVENUE, could be used to subtract one from the other.

```

CREATE FUNCTION REVENUE ( INCOME, EXPENSES )
  RETURNS DECIMAL(8,2) SOURCE "-" ( DECIMAL, DECIMAL)

```

Alternately, the - (minus) operator could be overloaded using a function to subtract the new data types.

```

CREATE FUNCTION "-" ( INCOME, EXPENSES )
  RETURNS DECIMAL(8,2) SOURCE "-" ( DECIMAL, DECIMAL)

```

Alternatively, the distinct type can be cast to a built-in data type and the result used as an operand of an arithmetic operator.

Scalar-fullselect

A *scalar-fullselect* as supported in an expression is a fullselect, enclosed in parentheses, that returns a single row consisting of a single column value. If the fullselect does not return a row, the result of the expression is the null value. If more than one row is to be returned for a scalar fullselect, an error occurs.

```

▶▶ ( — fullselect — ) ▶▶

```

If a set operator is not specified in the outermost fullselect and the select list element is an expression that is simply a column name, the result column name is based on the name of the column. Otherwise, the result column is unnamed.

If a column mask is defined to mask the column values in the final result, and if a column mask is applied to the column in the select list of a *scalar-fullselect*, the result of the *scalar-fullselect* must not be derived using set operator EXCEPT or INTERSECT. See [Chapter 6, “Queries,” on page 1007](#) for more information about how column access controls affect a fullselect.

A scalar fullselect cannot be used in the following instances:

- A CHECK constraint in CREATE TABLE and ALTER TABLE statements
- A CREATE VIEW statement where the view definition includes the WITH CHECK option
- A CREATE FUNCTION (SQL) statement (subselect already restricted from the expression in the RETURN clause)
- An argument in a CALL statement for an input parameter
- An argument to an aggregate function, other than the *XML-expression* argument of the XMLAGG function
- An ORDER BY clause
- A GROUP BY clause
- A join-condition of the ON clause for INNER and OUTER JOINS

If the scalar fullselect is a subselect, it is also referred to as a scalar subselect. See [“subselect” on page 1009](#) for more information.

The following examples illustrate the use of *scalar-fullselect*. Assume that four tables (PARTS, PRODUCTS, PARTPRICE, and PARTINVENTORY) contain product data.

Example 1 - *scalar-fullselect* in a WHERE clause:

Find which products have the prices in the range of at least twice the lowest price of all the products and at most half the price of all the products.

```
SELECT PRODUCT, PRICE FROM PRODUCTS A
WHERE
  PRICE BETWEEN 2 * (SELECT MIN(PRICE) FROM PRODUCTS)
  AND .5 * (SELECT MAX(PRICE) FROM PRODUCTS);
```

Example 2 - *scalar-fullselect* in a SELECT list:

For each part, find its price and its inventory.

```
SELECT PART,
  (SELECT PRICE FROM PARTPRICE WHERE PART=A.PART),
  (SELECT ONHAND# FROM INVENTORY WHERE PART=A.PART)
FROM PARTS A;
```

Datetime operands and durations

Datetime values can be incremented, decremented, and subtracted. These operations can involve decimal numbers called durations. A *duration* is a positive or negative number representing an interval of time.

Labeled durations

The form a labeled duration is as follows:

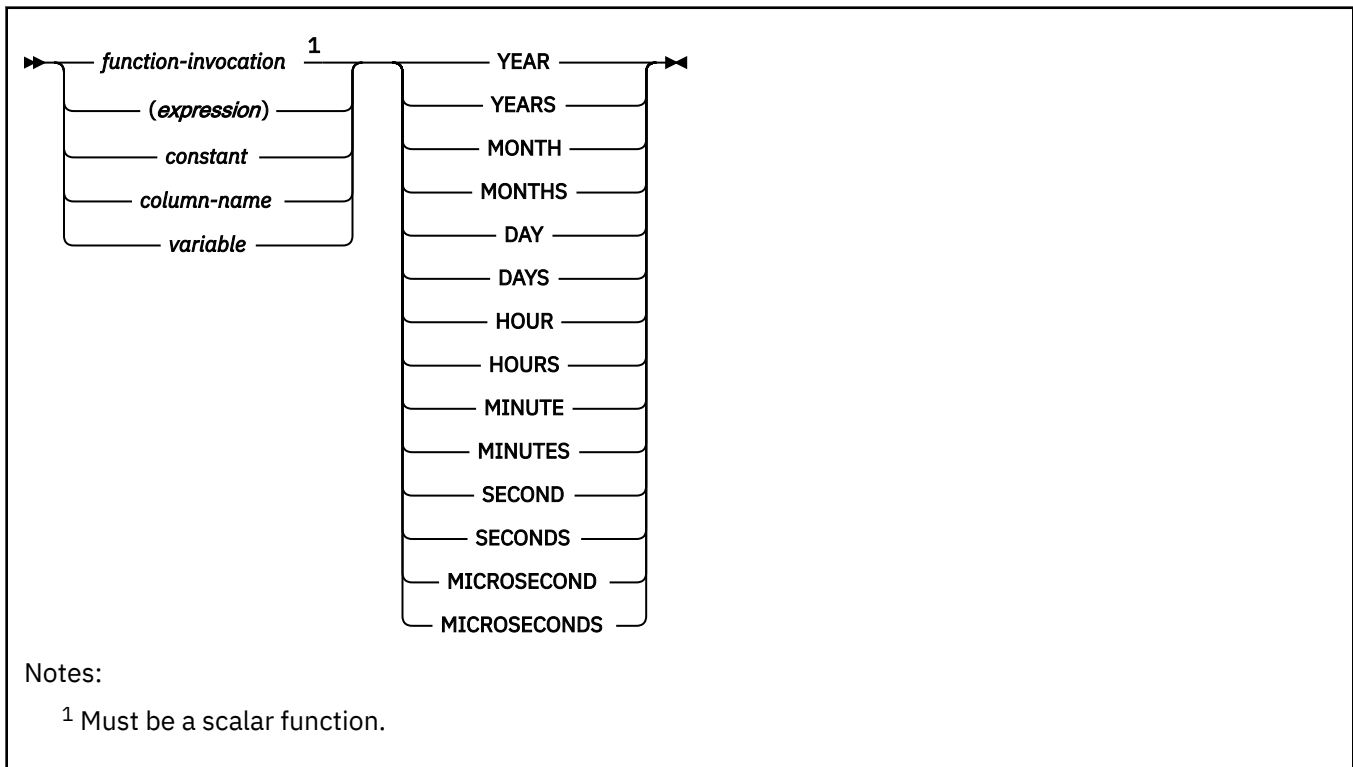

Notes:

¹ Must be a scalar function.

A *labeled duration* represents a specific unit of time as expressed by a number (which can be the result of an expression) followed by one of the seven duration keywords.¹⁴ The number specified is converted as if it were assigned to a DECIMAL(15,0) number, except for SECONDS, which uses DECIMAL(27,12) to allow 0 to 12 fractional second digits to be included.

¹⁴ The singular form of these keywords is also acceptable: YEAR, MONTH, DAY, HOUR, MINUTE, SECOND, and MICROSECOND.

A labeled duration can only be used as an operand of an arithmetic operator in which the other operand is a value of the data type of date, time, or timestamp. Thus, the expression `HIREDATE + 2 MONTHS + 14 DAYS` is valid, whereas the expression `HIREDATE + (2 MONTHS + 14 DAYS)` is not. In both of these expressions, the labeled durations are `2 MONTHS` and `14 DAYS`.

Date duration

A *date duration* represents a number of years, months, and days expressed as a `DECIMAL(8,0)` number. To be properly interpreted, the number must have the format `yyyymmdd`, where `yyyy` represents the number of years, `mm` the number of months, and `dd` the number of days. The result of subtracting one `DATE` value from another, as in the expression `HIREDATE - BIRTHDATE`, is a date duration.

Time duration

A *time duration* represents a number of hours, minutes, and seconds expressed as a `DECIMAL(6,0)` number. To be properly interpreted, the number must have the format `hhmmss`, where `hh` represents the number of hours, `mm` the number of minutes, and `ss` the number of seconds. The result of subtracting one `TIME` value from another is a time duration.

Timestamp duration

A *timestamp duration* represents a number of years, months, days, hours, minutes, seconds, and fractional seconds expressed as a `DECIMAL(14+s,s)` number, where `s` is the number of fractional seconds in the range from 0 to 12. To be interpreted properly, the number must have the format `yyyxxddhhmmss.zzzzzzzzzzzz`, where `yyyy`, `xx`, `dd`, `hh`, `mm`, `ss`, and `zzzzzzzzzzzz` represent, respectively, the number of years, months, days, hours, minutes, seconds, and fractional seconds. The result of subtracting one timestamp value from another is a timestamp duration with a scale that matches the maximum timestamp precision of the timestamp operands.

Time zone specific expressions

Time zone specific expressions can be used to adjust timestamp values and character-string or graphic-string representations of timestamp values to specific time zones.

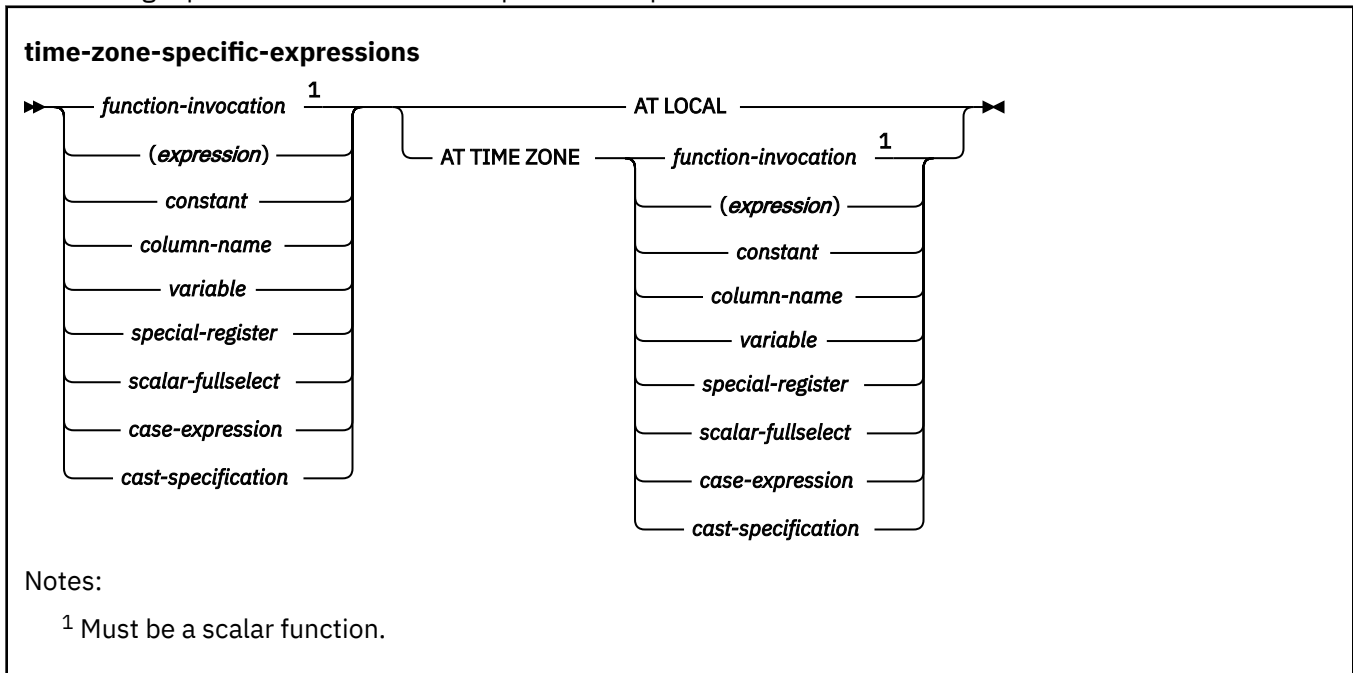

The first operand for *time-zone-specific-expression* must be an expression that returns the value of either a built-in timestamp or a built-in character or graphic string data type. If the first operand is a character string or graphic string, it must not be a CLOB or DBCLOB value and its value must be a valid character-string or graphic-string representation of a timestamp. For the valid formats of string representations of datetime values, see [“String representations of datetime values”](#) on page 120.

If the first operand of *time-zone-specific-expression* returns a `TIMESTAMP WITHOUT TIME ZONE` value, the expression is implicitly cast to `TIMESTAMP WITH TIME ZONE` before being adjusted to the indicated time zone.

AT LOCAL

Specifies that the timestamp value is to be adjusted for the local time zone using the `SESSION TIME ZONE` special register.

AT TIME ZONE

Specifies that the timestamp is to be adjusted for the time zone that is represented by the expression.

expression is a character or graphic string. It must not be a `CLOB` or `DBCLOB` value, and its value must be left justified and be of the form `'±th:tm'`, where *th* represents the time zone hour between -12 and +14, and *tm* represents the time zone minutes in the range 0–59, with values ranging from -12:59 to +14:00. The value must not be the null value.

The expression returns a `TIMESTAMP WITH TIME ZONE` value in the indicated time zone.

Syntax alternatives: `TIMEZONE` can be specified as an alternative to `TIME ZONE`.

Example 1

```
CAST('2010-04-12-10:30:00.0 -5:00' AT LOCAL AS TIMESTAMP)
```

Returns: 2010-04-12-07:30:00.000000.

Example 2

Insert a timestamp value with a time zone into a table, `tz`, and retrieve it as a timestamp with the local time zone, with `+08:00`, and adjusted for UTC. Assume that table `tz` exists as follows:

```
CREATE TABLE tz(tstz TIMESTAMP WITH TIME ZONE);
INSERT INTO tz(tstz) VALUES(TIMESTAMP '2010-01-01-10.23.51-08:00');
```

1. Retrieve the value of the `tstz` column adjusted for the local time:

```
SELECT tstz AT LOCAL
FROM tz;
```

2. Retrieve the value of the `tstz` column adjusted for the time zone `+08:00`:

```
SELECT tstz AT TIME ZONE '+08:00'
FROM tz;
```

3. Retrieve the value of the `tstz` column adjusted for UTC:

```
SELECT tstz AT TIME ZONE '+0:00'
FROM tz;
```

Datetime arithmetic in SQL

The only arithmetic operations that can be performed on datetime values are addition and subtraction.

If a datetime value is the operand of addition, the other operand must be a duration. The specific rules governing the use of the addition operator with datetime values follow.

- If one operand is a date, the other operand must be a date duration or labeled duration of years, months, or days.
- If one operand is a time, the other operand must be a time duration or a labeled duration of hours, minutes, or seconds.
- If one operand is a timestamp, the other operand must be a duration. Any type of duration is valid.
- Neither operand of the addition operator can be a parameter marker. For a discussion of parameter markers, see [Parameter markers](#) in “[PREPARE statement](#)” on page 2042.

The rules for the use of the subtraction operator on datetime values are not the same as those for addition because a datetime value cannot be subtracted from a duration, and because the operation of subtracting two datetime values is not the same as the operation of subtracting a duration from a datetime value. The specific rules governing the use of the subtraction operator with datetime values follow.

- If the first operand is a date, the second operand must be a date, a date duration, a string representation of a date, or a labeled duration of years, months, or days.
- If the second operand is a date, the first operand must be a date, or a string representation of a date.
- If the first operand is a time, the second operand must be a time, a time duration, a string representation of a time, or a labeled duration of hours, minutes, or seconds.
- If the second operand is a time, the first operand must be a time, or string representation of a time.
- If the first operand is a timestamp, the second operand must be a timestamp, a string representation of a timestamp, or a duration. If the second operand is a string representation of a timestamp, it is implicitly converted to a timestamp with the same precision as the first operand.
- If the second operand is a timestamp, the first operand must be a timestamp or a string representation of a timestamp. If the first operand is a string representation of a timestamp, it is implicitly converted to a timestamp with the same precision as the second operand.
- Neither operand of the subtraction operator can be a parameter marker.

When an operand in a datetime expression is a string, it might undergo character conversion before it is interpreted and converted to a datetime value. When its CCSID is not that of the default for mixed strings, a mixed string is converted to the default mixed data representation. When its CCSID is not that of the default for SBCS strings, an SBCS string is converted to the default SBCS representation.

Date arithmetic

Date values can be subtracted, incremented, or decremented.

Subtracting dates: The result of subtracting one date (DATE2) from another (DATE1) is a date duration that specifies the number of years, months, and days between the two dates. The data type of the result is DECIMAL(8,0). If DATE1 is greater than or equal to DATE2, DATE2 is subtracted from DATE1. If DATE1 is less than DATE2, however, DATE1 is subtracted from DATE2, and the sign of the result is made negative. The following procedural description clarifies the steps involved in the operation $RESULT = DATE1 - DATE2$.

Date subtraction: result = date1 - date2
<ul style="list-style-type: none"> • If $DAY(DATE2) \leq DAY(DATE1)$ then $DAY(RESULT) = DAY(DATE1) - DAY(DATE2)$ • If $DAY(DATE2) > DAY(DATE1)$ then $DAY(RESULT) = N + DAY(DATE1) - DAY(DATE2)$ where N = the last day of $MONTH(DATE2)$. $MONTH(DATE2)$ is then incremented by 1. • If $MONTH(DATE2) \leq MONTH(DATE1)$ then $MONTH(RESULT) = MONTH(DATE1) - MONTH(DATE2)$ • If $MONTH(DATE2) > MONTH(DATE1)$ then $MONTH(RESULT) = 12 + MONTH(DATE1) - MONTH(DATE2)$ and $YEAR(DATE2)$ is incremented by 1. • $YEAR(RESULT) = YEAR(DATE1) - YEAR(DATE2)$

For example, the result of $DATE('3/15/2005') - '12/31/2004'$ is 215 (or, a duration of 0 years, 2 months, and 15 days). In this example, notice that the second operand did not need to be converted to a date. According to one of the rules for subtraction, described under “Datetime arithmetic in SQL” on page 259, the second operand can be a string representation of a date if the first operand is a date.

Incrementing and decrementing dates: The result of adding a duration to a date, or of subtracting a duration from a date, is itself a date. (For the purposes of this operation, a month denotes the equivalent of a calendar page. Adding months to a date, then, is like turning the pages of a calendar, starting with the page on which the date appears.) The result must fall between the dates January 1, 0001 and December 31, 9999 inclusive. If a duration of years is added or subtracted, only the year portion of the

date is affected. The month is unchanged, as is the day unless the result would be February 29 of a non-leap-year. Here the day portion of the result is set to 28, and the SQLWARN6 field of the SQLCA is set to W, indicating that an end-of-month adjustment was made to correct an invalid date. [“Description of SQLCA fields”](#) on page 2303 also describes how SQLWARN6 is set.

Similarly, if a duration of months is added or subtracted, only months and, if necessary, years are affected. The day portion of the date is unchanged unless the result would be invalid (September 31, for example). In this case the day is set to the last day of the month, and the SQLWARN6 field of the SQLCA is set to W to indicate the adjustment.

Adding or subtracting a duration of days will, of course, affect the day portion of the date, and potentially the month and year. Adding or subtracting a duration of days will not cause an end-of-the-month adjustment.

Date durations, whether positive or negative, can also be added to and subtracted from dates. As with labeled durations, the result is a valid date, and SQLWARN6 is set to W to indicate any necessary end-of-month adjustment.

When a positive date duration is added to a date, or a negative date duration is subtracted from a date, the date is incremented by the specified number of years, months, and days, in that order. Thus, DATE1+X, where X is a positive DECIMAL(8,0) number, is equivalent to the expression:

```
DATE1 + YEAR(X) YEARS + MONTH(X) MONTHS + DAY(X) DAYS
```

When a positive date duration is subtracted from a date, or a negative date duration is added to a date, the date is decremented by the specified number of days, months, and years, in that order. Thus, DATE1-X, where X is a positive DECIMAL(8,0) number, is equivalent to the expression:

```
DATE1 - DAY(X) DAYS - MONTH(X) MONTHS - YEAR(X) YEARS
```

Adding a month to a date gives the same day one month later unless that day does not exist in the later month. In that case, the day in the result is set to the last day of the later month. For example, January 28 plus one month gives February 28; one month added to January 29, 30, or 31 results in either February 28 or, for a leap year, February 29. If one or more months is added to a given date and then the same number of months is subtracted from the result, the final date is not necessarily the same as the original date.

If one or more months are added to a given date and then the same number of months is subtracted from the result, the final date is not necessarily the same as the original date. In addition, logically equivalent expressions might not produce the same result. For example, the following two expressions do not produce the same result:

```
(DATE('2005 01 31') + 1 MONTH) + 1 MONTH    -- results in 2005-03-28
DATE('2005 01 31') + 2 MONTHS                -- results in 2005-03-31
```

The order in which labeled date durations are added to and subtracted from dates can affect the results. When you add labeled date durations to a date, specify them in the order of YEARS + MONTHS + DAYS. When you subtract labeled date durations from a date, specify them in the order of DAYS - MONTHS - YEARS. For example, to add one year and one day to a date, specify:

```
DATE1 + 1 YEAR + 1 DAY
```

To subtract one year, one month, and one day from a date, specify:

```
DATE1 - 1 DAY - 1 MONTH - 1 YEAR
```

Time arithmetic

Times can be subtracted, incremented, or decremented.

Subtracting times: The result of subtracting one time (*TIME2*) from another (*TIME1*) is a time duration that specifies the number of hours, minutes, and seconds between the two times. The data type of the result is DECIMAL(6,0). If *TIME1* is greater than or equal to *TIME2*, *TIME2* is subtracted from *TIME1*. If

TIME1 is less than *TIME2*, however, *TIME1* is subtracted from *TIME2*, and the sign of the result is made negative. The following procedural description clarifies the steps involved in the operation $RESULT = TIME1 - TIME2$.

Time subtraction: result = time1 - time2

- If $SECOND(TIME2) \leq SECOND(TIME1)$ then $SECOND(RESULT) = SECOND(TIME1) - SECOND(TIME2)$.
- If $SECOND(TIME2) > SECOND(TIME1)$ then $SECOND(RESULT) = 60 + SECOND(TIME1) - SECOND(TIME2)$ and $MINUTE(TIME2)$ is incremented by 1.
- If $MINUTE(TIME2) \leq MINUTE(TIME1)$ then $MINUTE(RESULT) = MINUTE(TIME1) - MINUTE(TIME2)$.
- If $MINUTE(TIME2) > MINUTE(TIME1)$ then $MINUTE(RESULT) = 60 + MINUTE(TIME1) - MINUTE(TIME2)$ and $HOUR(TIME2)$ is incremented by 1.
- $HOUR(RESULT) = HOUR(TIME1) - HOUR(TIME2)$.

For example, the result of $TIME('11:02:26') - '00:32:56'$ is '102930' (a duration of 10 hours, 29 minutes, and 30 seconds). In this example, notice that the second operand did not need to be converted to a time. According to one of the rules for subtraction, described under “Datetime arithmetic in SQL” on page 259, the second operand can be a string representation of a time if the first operand is a time.

Incrementing and decrementing times: The result of adding a duration to a time, or of subtracting a duration from a time, is itself a time. Any overflow or underflow of hours is discarded, thereby ensuring that the result is always a time. If a duration of hours is added or subtracted, only the hours portion of the time is affected. Adding 24 hours to the time '00:00:00' results in the time '24:00:00'. However, adding 24 hours to any other time results in the same time; for example, adding 24 hours to the time '00:00:59' results in the time '00:00:59'. The minutes and seconds are unchanged.

Similarly, if a duration of minutes is added or subtracted, only minutes and, if necessary, hours are affected. The seconds portion of the time is unchanged.

Adding or subtracting a duration of seconds affects the seconds portion of the time and might affect the minutes and hours.

Time durations, whether positive or negative, can also be added to and subtracted from times. The result is a time that has been incremented or decremented by the specified number of hours, minutes, and seconds, in that order. Thus, $TIME1 + X$, where X is a positive $DECIMAL(6,0)$ number, is equivalent to the expression

```
TIME1 + HOUR(X) HOURS + MINUTE(X) MINUTES + SECOND(X) SECONDS
```

Timestamp arithmetic

Timestamps can be subtracted, incremented, or decremented.

If any of the operands are `TIMESTAMP WITH TIME ZONE`, any `TIMESTAMP WITHOUT TIME ZONE` values are implicitly cast to `TIMESTAMP WITH TIME ZONE`, and the datetime arithmetic operation is performed in UTC time (ignoring the time zone).

Subtracting timestamps: The result of subtracting one timestamp (*TS2*) from another (*TS1*) is a timestamp duration that specifies the number of years, months, days, hours, minutes, seconds, and fractional seconds between the two timestamps.

The data type of the result is $DECIMAL(14+s,s)$, where s is the maximum timestamp precision of *TS1* and *TS2*. If *TS1* is greater than or equal to *TS2*, *TS2* is subtracted from *TS1*. If *TS1* is less than *TS2*. However, *TS1* is subtracted from *TS2* and the sign of the result is made negative. A subtraction that involves a timestamp with a time zone operand is based on the UTC value of the timestamp with the time zone. The time zone is ignored.

The following procedural description clarifies the steps involved in the operation $RESULT = TS1 - TS2$.

Timestamp subtraction: $result = ts1 - ts2$

- If $MICROSECOND(TS2) \leq MICROSECOND(TS1)$ then $MICROSECOND(RESULT) = MICROSECOND(TS1) - MICROSECOND(TS2)$.
- If $MICROSECOND(TS2) > MICROSECOND(TS1)$ then $MICROSECOND(RESULT) = 1000000 + MICROSECOND(TS1) - MICROSECOND(TS2)$ and $SECOND(TS2)$ is incremented by 1.
- If $SECOND(TS2, s) \leq SECOND(TS1, s)$ then $SECOND(RESULT, s) = SECOND(TS1, s) - SECOND(TS2, s)$.
- If $SECOND(TS2, s) > SECOND(TS1, s)$ then $SECOND(RESULT, s) = 60 + SECOND(TS1, s) - SECOND(TS2, s)$.
 $MINUTE(TS2)$ is incremented by 1.
- If $HOUR(TS2) \leq HOUR(TS1)$ then $HOUR(RESULT) = HOUR(TS1) - HOUR(TS2)$.
- If $HOUR(TS2) > HOUR(TS1)$ then $HOUR(RESULT) = 24 + HOUR(TS1) - HOUR(TS2)$ and $DAY(TS2)$ is incremented by 1.

The minutes part of the timestamps are subtracted as specified in the rules for subtracting times.

The date part of the timestamps is subtracted as specified in the rules for subtracting dates.

Incrementing and decrementing timestamps: The result of adding a duration to a timestamp, or of subtracting a duration from a timestamp, is itself a timestamp. The precision of the result timestamp matches the precision of the timestamp operand. The date and time arithmetic is performed as previously defined, except that an overflow or underflow of hours is carried into the date part of the result, which must be within the range of valid dates. The time arithmetic portion is similar to time arithmetic, except that it also considers the fractional seconds included in the duration. For example, subtracting a duration, X , from a timestamp, $TIMESTAMP1$, where X is a $DECIMAL(14+s,s)$ number, is equivalent to the expression:

```
TIMESTAMP1 - YEAR(X) YEARS - MONTH(X) MONTHS - DAY(X) DAYS
             - HOUR(X) HOURS - MINUTE(X) MINUTES - SECOND(X, s) SECONDS
```

When subtracting a duration with a non-zero scale or a labeled duration of `SECOND` or `SECONDS` with a value that includes fractions of a second, the subtraction is performed as if the timestamp value has up to 12 fractional second digits. The resulting value is assigned to a timestamp value with the timestamp precision of the timestamp operand, which could result in truncation of fractional second digits.

When the result of an operation is midnight, the time portion of the result can be '24.00.00' or '00.00.00'. A comparison of those two values does not result in 'equal'. Microseconds overflow into seconds.

Precedence of operations

Expressions within parentheses are evaluated first. When the order of evaluation is not specified by parentheses, prefix operators are applied before multiplication and division, and multiplication, division, and concatenation are applied before addition and subtraction. Operators at the same precedence level are applied from left to right.

Example 1: In this example, the first operation is the addition in $(SALARY + BONUS)$ because it is within parenthesis. The second operation is multiplication because it is a higher precedence level than the second addition operator and it is to the left of the division operator. The third operation is division because it is at a higher precedence level than the second addition operator. Finally, the remaining addition is performed.

```
1.10 * (SALARY + BONUS) + SALARY / :VAR3
      (2)      (1)      (4)      (3)
```

Example 2: In this example, the first operation (`CONCAT`) combines the character strings in the variables `YYYYMM` and `DD` into a string representing a date. The second operation (`-`) then subtracts that date

from the date being processed in DATECOL. The result is a date duration that indicates the time elapsed between the two dates.

```
DATECOL - :YYYYMM CONCAT :DD
         (2)          (1)
```

CASE expressions

A CASE expression allows an expression to be selected based on the evaluation of one or more conditions.

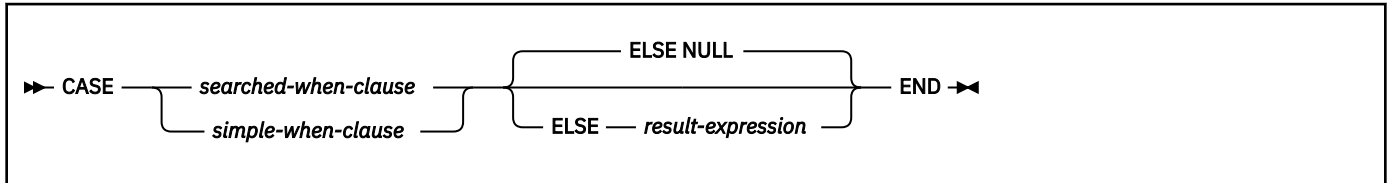

searched-when-clause:

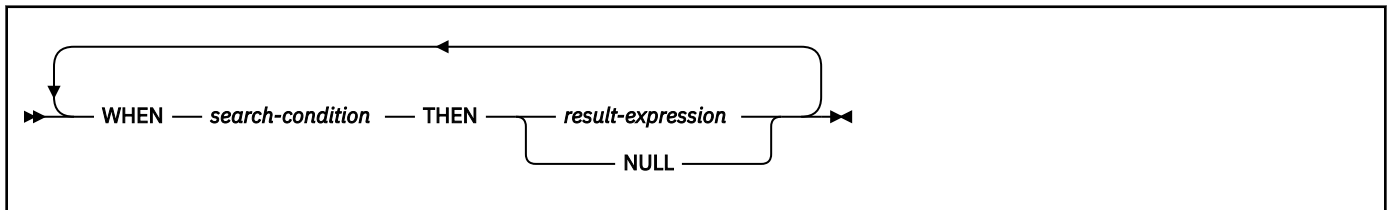

simple-when-clause:

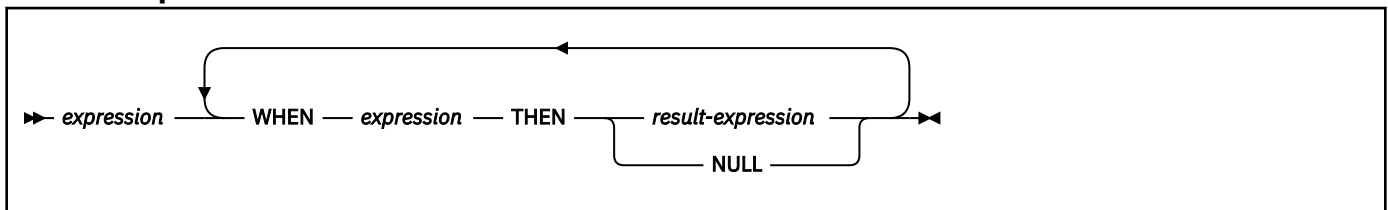

In general, the value of the *case-expression* is the value of the *result-expression* following the first (leftmost) *when-clause* that evaluates to true. If no case evaluates to true and the ELSE keyword is present, the result is the value of the *result-expression* or NULL. If no case evaluates to true and the ELSE keyword is not present, the result is NULL. When a case evaluates to unknown (because of NULL values), the case is NOT true and hence is treated the same way as a case that evaluates to false.

searched-when-clause

Specifies a *search-condition* that is applied to each row or group of table data presented for evaluation, and the result when that condition is true.

Pair-wise comparison is performed. Implicit cast of each pair follows the same rule as for a basic predicate. The *searched-when-clause* performs implicit cast on string and numeric search conditions.

simple-when-clause

Specifies that the value of the *expression* prior to the first WHEN keyword is tested for equality with the value of each *expression* that follows the WHEN keyword. It also specifies the result for when that condition is true.

The data type of the *expression* prior to the first WHEN keyword must be compatible with the data types of the *expression* that follows each WHEN keyword. The data type of any of the expressions cannot be a CLOB, DBCLOB or BLOB. In addition, the *expression* prior to the first WHEN keyword cannot include a function that is not deterministic or has an external action.

result-expression or NULL

Specifies the value that follows the THEN and ELSE keywords. It specifies the result of a *searched-when-clause* or a *simple-when-clause* that is true, or the result if no case is true. There must be at least one *result-expression* in the CASE expression with a defined data type. NULL cannot be specified for every case.

All *result-expressions* must have compatible data types. The attributes of the result are determined according to the rules that are described in “Rules for result data types” on page 166. When the result is a string, its attributes include a CCSID. For the rules on how the CCSID is determined, see [Determining the encoding scheme and CCSID of a string \(Introduction to Db2 for z/OS\)](#).

search-condition

Specifies a condition that is true, false, or unknown about a row or group of table data. The *search-condition* can be a predicate, including predicates that contain fullselects (scalar or non-scalar) or row-value expressions.

If *search-condition* in a *searched-when-clause* specifies a quantified predicate or an IN predicate that includes a fullselect, the CASE expression cannot be used in the following contexts:

- select lists
- a VALUES clause of an INSERT or MERGE statement
- a SET or assignment clause of an UPDATE, MERGE, or DELETE statement
- the right side of a SET or assignment statement
- the definition of a column mask or a row permission

If *search-condition* in a *searched-when-clause* specifies an EXISTS predicate, the CASE expression cannot be used in the following contexts:

- a VALUES clause of an INSERT or MERGE statement
- the right side of a SET or assignment statement
- The *diagnostic-string-expression* of a SIGNAL statement
- An ORDER BY clause or a GROUP BY clause

END

Ends a *case-expression*.

If a CASE expression is in a select list that derives the final result table, and if the *simple-when-clause* or the *searched-when-clause* references a basic predicate with a fullselect, column masks cannot be applied to the columns in the THEN clauses which derive the result of the CASE expression.

If a CASE expression is in a select list that derives the final result table, and if the *simple-when-clause* or *searched-when-clause* references a column for which column access control is activated, the column mask cannot be applied to the column and an error is returned.

If a CASE expression is in a SET clause of an UPDATE, MERGE, or DELETE statement, a VALUES clause of an INSERT or MERGE statement, or the fullselect of an INSERT from a fullselect, and if the *simple-when-clause* or the *searched-when-clause* references a column for which column access control is activated, the column access control is ignored for the column.

Two scalar functions, NULLIF and COALESCE, are specialized to handle a subset of the functionality provided by CASE. The following table shows the equivalent expressions using CASE or these functions.

Table 51. Equivalent case expressions

CASE expression	Equivalent expression
CASE WHEN e1=e2 THEN NULL ELSE e1 END	NULLIF(e1,e2)

Table 51. Equivalent case expressions (continued)

CASE expression	Equivalent expression
CASE WHEN e1 IS NOT NULL THEN e1 ELSE e2 END	COALESCE(e1,e2)
CASE WHEN e1 IS NOT NULL THEN e1 ELSE COALESCE(e2,...,eN) END	COALESCE(e1,e2,...,eN)

Example 1 (simple-when-clause): Assume that in the EMPLOYEE table the first character of a department number represents the division in the organization. Use a CASE expression to list the full name of the division to which each employee belongs.

```
SELECT EMPNO, LASTNAME,
       CASE SUBSTR(WORKDEPT,1,1)
         WHEN 'A' THEN 'Administration'
         WHEN 'B' THEN 'Human Resources'
         WHEN 'C' THEN 'Design'
         WHEN 'D' THEN 'Operations'
       END
FROM EMPLOYEE;
```

Example 2 (searched-when-clause): You can also use a CASE expression to avoid "division by zero" errors. From the EMPLOYEE table, find all employees who earn more than 25 percent of their income from commission, but who are not fully paid on commission:

```
SELECT EMPNO, WORKDEPT, SALARY+COMM FROM EMPLOYEE
WHERE (CASE WHEN SALARY=0 THEN 0
          ELSE COMM/(SALARY+COMM)
        END) > 0.25;
```

Example 3 (searched-when-clause): You can use a CASE expression to avoid "division by zero" errors in another way. The following queries show an accumulation or summing operation. In the first query, Db2 performs the division before performing the CASE statement and an error occurs along with the results.

```
SELECT REF_ID,PAYMT_PAST_DUE_CT,
       CASE
         WHEN PAYMT_PAST_DUE_CT=0 THEN 0
         WHEN PAYMT_PAST_DUE_CT>0 THEN
           SUM(BAL_AMT/PAYMT_PAST_DUE_CT)
       END
FROM PAY_TABLE
GROUP BY REF_ID,PAYMT_PAST_DUE_CT;
```

However, if the CASE expression is included in the SUM aggregate function, the CASE expression would prevent the errors. In the following query, the CASE expression screens out the unwanted division because the CASE operation is performed before the division.

```
SELECT REF_ID,PAYMT_PAST_DUE_CT,
       SUM(CASE
         WHEN PAYMT_PAST_DUE_CT=0 THEN 0
         WHEN PAYMT_PAST_DUE_CT>0 THEN
           BAL_AMT/PAYMT_PAST_DUE_CT
         END)
FROM PAY_TABLE
GROUP BY REF_ID,PAYMT_PAST_DUE_CT;
```

Example 4: This example shows how to group the results of a query by a CASE expression without having to re-type the expression. Using the sample employee table, find the maximum, minimum, and average salary. Instead of finding these values for each department, assume that you want to combine some departments into the same group.

```
SELECT CASE_DEPT,MAX(SALARY),MIN(SALARY),AVG(SALARY)
FROM (SELECT SALARY,CASE WHEN WORKDEPT = 'A00' OR WORKDEPT = 'E21'
                        THEN 'A00_E21'
                        WHEN WORKDEPT = 'D11' OR WORKDEPT = 'E11'
```

```
        THEN 'D11_E11'  
        ELSE WORKDEPT  
    END AS CASE_DEPT  
FROM DSN8C10.EMP) X  
GROUP BY CASE_DEPT;
```

CAST specification

The CAST specification returns the first operand (the cast operand) converted to the data type that is specified by *data-type*.

Syntax for CAST specification

►► CAST — (— *expression* — AS — *data-type* —) —◄◄
 ┌———┴———┐
 NULL
 └———┬———┘
 parameter-marker

data-type:

►► — *built-in-type* — ◄◄
┌———┴———┐
└———┬———┘
distinct-type-name
array-type

built-in-type:

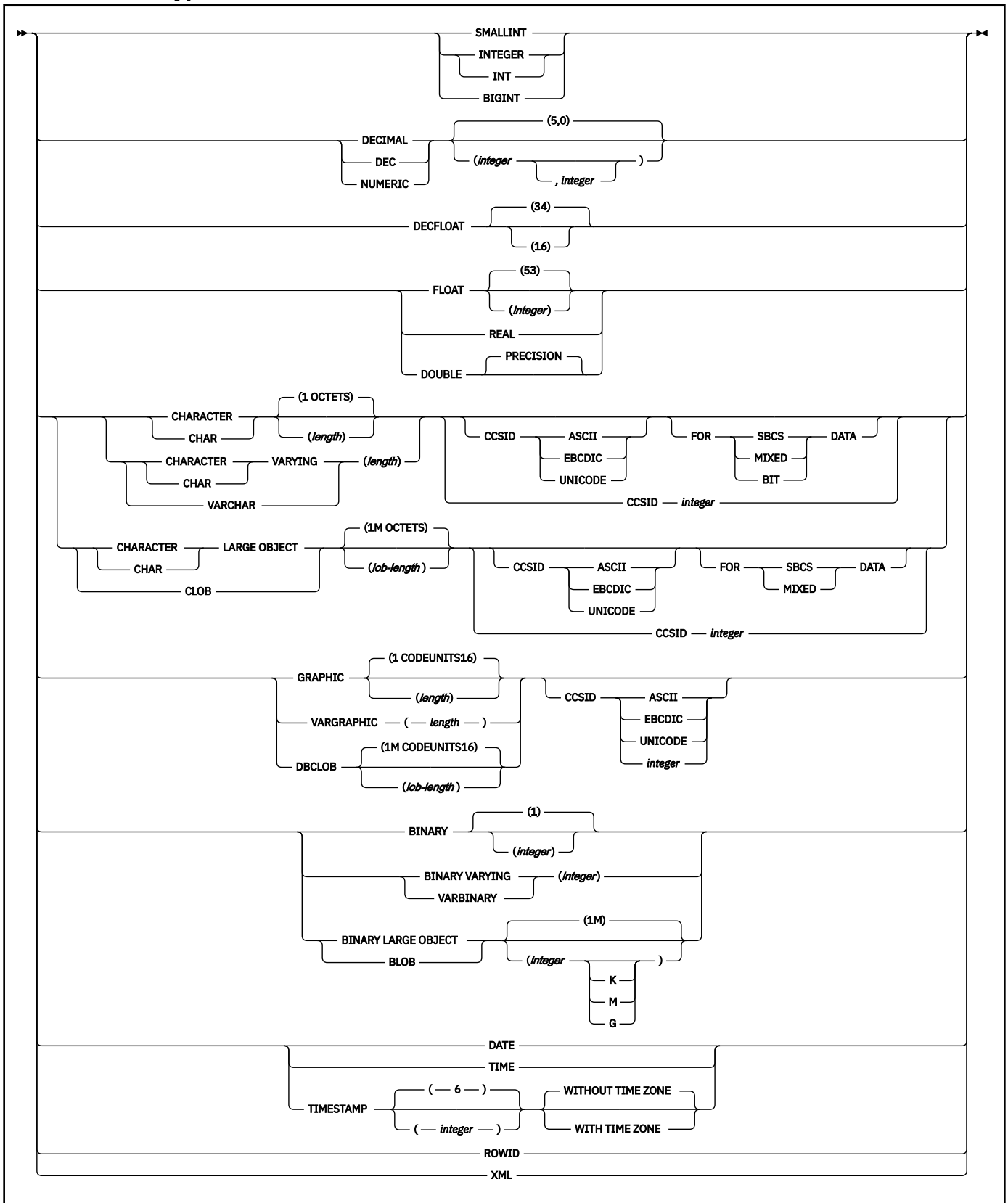

length:

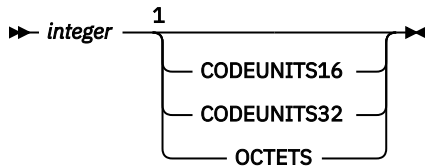

Notes:

¹ FL 502 OCTETS and CODEUNITS32 must not be specified with GRAPHIC and VARGRAPHIC when the first argument is numeric data.

lob-length:

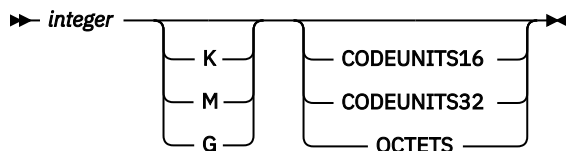

Description for CAST specification

If the data type of either operand is a distinct type, the privilege set must implicitly include EXECUTE authority on the generated cast functions for the distinct type. The CAST specification allows the second operand to be cast to a particular encoding scheme or CCSID if the second operand represents character data. The CCSID clause can be specified following CHAR, VARCHAR, CLOB, GRAPHIC, VARGRAPHIC, and DBCLOB data types.

expression

Specifies that the cast operand is an expression other than NULL or a parameter marker. The result is the value of the operand value converted to the specified target *data type*.

The supported casts are shown in [“Casting between data types”](#) on page 130. If the cast is not supported, an error is returned.

When any data type is cast to a character for graphic data type, a warning if any non-blank characters are truncated. The warning also occurs if any characters are truncated when a BLOB operand is cast, or if the time zone characters are truncated when a TIMESTAMP WITH TIME ZONE operand is cast to a string.

NULL

Specifies that the cast operand is null. The result is a null value with the specified target *data type*.

parameter-marker

A parameter marker, which is normally considered an expression, has a special meaning as a cast operand. When the cast operand is a *parameter-marker*, the *data type* that is specified represents the "promise" that the replacement value for the parameter marker will be assignable to the specified data type (using "store assignment" rules). Such a parameter marker is considered a *typed parameter marker*. Typed parameter markers are treated like any other typed value for the purpose of function resolution, a DESCRIBE of a select list, or column assignment.

data-type

Specifies the data type of the result. If the data type is not qualified, the SQL path is used to find the appropriate data type. For more information, see [“SQL path”](#) on page 85.

SMALLINT

For a small integer.

INTEGER or INT

For a large integer.

BIGINT

For a big integer.

DECIMAL(*integer, integer*) or DEC(*integer, integer*)**DECIMAL(*integer*) or DEC(*integer*)****DECIMAL or DEC**

For a decimal number. The first integer is the precision of the number. That is, the total number of digits 1–31. The second integer is the scale of the number. That is, the number of digits to the right of the decimal point, which can range from 0 to the precision of the number.

You can use DECIMAL(*p*) for DECIMAL(*p*,0) and DECIMAL for DECIMAL(5,0).

You can also use the word NUMERIC instead of DECIMAL. For example, NUMERIC(8) is equivalent to DECIMAL(8). Unlike DECIMAL, NUMERIC has no allowable abbreviation.

DECFLOAT(*integer*)

For a decimal floating-point number. The value of *integer* must be either 16 or 34 and represents the number of significant digits that can be stored. If *integer* is omitted, the DECFLOAT value can represent 34 significant digits.

FLOAT(*integer*)**FLOAT**

For a floating-point number. If *integer* is in the range 1– 21 inclusive, the format is single precision floating-point. If the integer is in the range 22–53 inclusive, the format is double precision floating-point.

You can use DOUBLE PRECISION or FLOAT for FLOAT(53).

For portability across operating systems, when specifying a floating-point data type, use REAL or DOUBLE instead of FLOAT.

REAL

For single precision floating-point.

DOUBLE or DOUBLE PRECISION

For double precision floating-point

CHARACTER(*integer*) or CHAR(*integer*)**CHARACTER or CHAR**

For a fixed-length character string of length *integer*, which can range 1–255. If the length specification is omitted, a length of 1 character is assumed.

You can specify that the length of the result be evaluated in a specific number of string units: CODEUNITS16, CODEUNITS32, or OCTETS. If *expression* is a character string that is defined as bit data, CODEUNITS16, or CODEUNITS32 cannot be specified. For more information, see [“String unit specifications” on page 106](#).

VARCHAR(*integer*), CHAR VARYING(*integer*), or CHARACTER VARYING(*integer*)

For a varying-length character string of maximum length *integer* in the range 1–32764.

You can specify that the length of the result be evaluated in a specific number of string units: CODEUNITS16, CODEUNITS32, or OCTETS. If *expression* is a character string that is defined as bit data, CODEUNITS16, or CODEUNITS32 cannot be specified. For more information, see [“String unit specifications” on page 106](#).

CLOB(*integer* [K|M|G]), CHAR LARGE OBJECT(*integer* [K|M|G]), or CHARACTER LARGE OBJECT(*integer* [K|M|G])**CLOB, CHAR LARGE OBJECT, or CHARACTER LARGE OBJECT**

For a character large object (CLOB) string of the specified maximum length in bytes. The maximum length must be in the range 1–2147483647.

When *integer* is not specified, the default length is 1 M. The maximum value that can be specified for *integer* depends on whether a units indicator is also specified as shown in the following list.

integer

The maximum value for *integer* is 2147483647. The maximum length of the string is *integer*.

integer K

The maximum value for *integer* is 2097152. The maximum length is 1024 times *integer*.

integer M

The maximum value for *integer* is 2048. The maximum length is 1,048,576 times *integer*.

integer G

The maximum value for *integer* is 2. The maximum length is 1,073,741,824 times *integer*.

integer can be separated from K, M, or G by 0 or more spaces.

If you specify a value that evaluates to 2 gigabytes (2,147,483,648), Db2 uses a value that is one byte less, or 2147483647.

You can specify that the length of the result be evaluated in a specific number of string units: CODEUNITS16, CODEUNITS32, or OCTETS. For more information, see [“String unit specifications” on page 106](#).

GRAPHIC(*length*)

GRAPHIC

For a fixed-length graphic string of length *integer*, which can range 1–127. If the length specification is omitted, a length of 1 character is assumed.

You can specify that the length of the result be evaluated in a specific number of string units: CODEUNITS16 or CODEUNITS32. For more information, see [“String unit specifications” on page 106](#).

VARGRAPHIC(*integer*)

For a varying-length graphic string of maximum length *integer* in the range 1–32764.

You can specify that the length of the result be evaluated in a specific number of string units: CODEUNITS16 or CODEUNITS32. For more information, see [“String unit specifications” on page 106](#).

DBCLOB(*integer* [K|M|G])

DBCLOB

For a double-byte character large object (DBCLOB) string of the specified maximum length in double-byte characters. The maximum length must be in the range 1–1,073,741,823.

When *integer* is not specified, the default length is 1M. The meaning of *integer* K|M|G is similar to CLOB. The difference is that the number specified is the number of double-byte characters.

integer can be separated from K, M, or G by 0 or more spaces.

You can specify that the length of the result be evaluated in a specific number of string units: CODEUNITS16, CODEUNITS32, or OCTETS. For more information, see [“String unit specifications” on page 106](#).

BINARY(*integer*)

A fixed-length binary string of length *integer*. The *integer* can range 1–255. If the length specification is omitted, a length of 1 byte is assumed.

BINARY VARYING(*integer*) or VARBINARY(*integer*)

A varying-length binary string of maximum length *integer* in the range 1–32764.

BLOB (*integer* [K|M|G]) or BINARY LARGE OBJECT(*integer* [K|M|G])

BLOB or BINARY LARGE OBJECT

For a binary large object (BLOB) string of the specified maximum length in bytes. The maximum length must be in the range 1–2147483647.

When *integer* is not specified, the default length is 1M. The meaning of *integer* K|M|G is the same as for CLOB.

integer can be separated from K, M, or G by 0 or more spaces.

DATE

For a date.

TIME

For a time.

TIMESTAMP(*integer*) WITHOUT TIME ZONE

For a timestamp. *integer* specifies the optional timestamp precision attribute and must be in the range 0–12. The timestamp precision denotes the number of fractional second digits that are included in the timestamp. The default is 6.

TIMESTAMP(*integer*) WITH TIME ZONE

For a timestamp with time zone. *integer* specifies the optional timestamp precision attribute and must be in the range 0–12. The timestamp precision denotes the number of fractional second digits that are included in the timestamp. The default is 6.

- If the cast operand is *expression*, see [“Casting between data types”](#) on page 130 and use any of the target data types that are supported for the data type of the cast operand.
- If the cast operand is NULL, you can use any data type.
- If the cast operand is a *parameter-marker*:
 - If the target data type is a distinct type, the application that uses the parameter marker uses the base data type of the distinct type.
 - If the target data type is an array type:
 - The elements in the source array value must be castable to the data type of the elements of the target array type. The index values for the source array value must be castable to the data type of the index of the target array type.
 - If the target array type is an ordinary array, the cardinality of the source array value must be less than or equal to the maximum cardinality of the target array type.
 - Otherwise, any data type if valid.

CCSID *encoding-scheme*

Specifies the encoding scheme for the target data type. The specific CCSIDs for SBCS, BIT, and MIXED data are determined by the default CCSIDs for the server for the specified encoding scheme. The valid values are ASCII, EBCDIC, and UNICODE.

FOR *subtype* DATA

Specifies a subtype for a character string value, which has a data type of CHAR, VARCHAR, or CLOB. Do not use the FOR *subtype* DATA clause with values of any other data type (including any distinct type). *subtype* is one of the following keywords:

SBCS

The value contains single-byte data.

MIXED

The value contains mixed data. Do not specify MIXED if the value of MIXED DECP value is NO.

BIT

Column holds BIT data. Do not specify BIT for a CLOB value. Only character strings are valid when subtype is BIT.

CCSID *integer*

Specifies that the target data type be encoded using the CCSID *integer*. The value must be one of the CCSID values in DECP. If the second operand is CHAR, VARCHAR, or CLOB, the CCSID specified must be either a SBCS, or MIXED CCSID, or 65535 for bit data. If the second operand is GRAPHIC, VARGRAPHIC, or DBCLOB, the CCSID specified must be a DBCS CCSID. See [Determining the CCSID of the result if neither CCSID *integer* nor CCSID *encoding-scheme* is specified](#). See [Determining the CCSID of the result for special considerations regarding CCSID 367](#).

Notes for CAST specification

Interaction between length and CCSID clauses

If both the *length* and CCSID clauses are specified, the data is first cast to the specified CCSID, and then the *length* is applied. If either CODEUNITS16 or CODEUNITS32 is specified, the specification of length applies to the units specified. That is, the data is converted to an intermediate form (in Unicode), the length is applied, and the data is converted to the specified CCSID.

Resolution of cast functions

Db2 uses the implicit or explicit schema name and the data type name of *data-type*, and function resolution to determine the specific function to use to convert *expression* to *data-type*. See [Qualified function resolution](#) for more information.

Result of the CAST

When numeric data is cast to character data, the data type of the result is a fixed-length character string, which is similar to the result that the CHAR function would give. (For more information, see [“CHAR scalar function” on page 405.](#)) When character data is cast to numeric data, the data type of the result depends on the data type of the specified number. For example, character data that is cast to an integer becomes a large integer, which is similar to the result that the INTEGER function would give. (For more information see [“INTEGER or INT scalar function” on page 483.](#))

If the data type of the result is character, and the FOR *subtype* DATA clause is not specified, the subtype of the result is determined by the following rules:

- If *expression* is graphic, the subtype of the result is mixed.
- If *expression* is a datetime data type, the subtype of the result is mixed. The exception is when the default encoding scheme is EBCDIC and there is no mixed or graphic data on the system for EBCDIC.
- If *expression* is a row ID and *data-type* is not CLOB, the result is bit data.
- If *expression* is character, the subtype of the result is the same as *expression*.
- Otherwise, the subtype depends on the encoding scheme of the result. If the encoding scheme of the result is not Unicode and the MIXED DECP value is NO, the subtype of the result is SBCS. Otherwise, the subtype of the result is mixed.

Casting constant values to DECFLOAT

To cast a constant value, where the value is negative zero, or a floating point constant to DECFLOAT, specify the value as a character string constant rather than a numeric constant. For example:

```
DECFLOAT('-0')           -- causes DB2 to retain the negative sign for a
                          -- value of negative zero
DECFLOAT('1.00E20')     -- causes DB2 to preserve the precision of the
                          -- floating point constant
```

Determining the CCSID and encoding scheme of the result

The CCSID of the result depends on whether the CCSID clause was specified and the context in which the CAST specification was specified.

If the CCSID clause was specified, the CCSID clause is used to determine the CCSID of the result as follows:

- If the CCSID clause was specified with EBCDIC, ASCII, or UNICODE, the clause determines the encoding scheme of the result. The CCSID of the result is the appropriate CCSID (from DECP) for that encoding scheme for the data type of the result.
- If the CCSID clause was specified with a numeric value representing bit data (65535), the CCSID of the result depends on the data type of the source. If the source data is not string data, the CCSID of the result is the appropriate CCSID for the application encoding scheme. See Note 1 in [Determining the encoding scheme and CCSID of a string \(Introduction to Db2 for z/OS\)](#). If the source is string data, the encoding scheme of the result is the same as the encoding scheme of expression, but the result is considered bit data.

- If the CCSID clause was specified with a numeric value, that number is the CCSID of the result. The encoding scheme of the result is determined from the numeric CCSID. In a CAST specification, CCSID 367 refers to ASCII data. For example, assume that MYDATA is string data to be cast to CHAR(10). The following CAST specification returns ASCII SBCS data:

```
CAST(MYDATA AS CHAR(10) CCSID 367)
```

To explicitly cast the data to Unicode SBCS, use the following syntax:

```
CAST(MYDATA AS CHAR(10) CCSID UNICODE
FOR SBCS DATA)
```

If the CCSID clause was not specified, the CCSID of the result is 65535 if the result is bit data. Otherwise, if the data type of the result is a character or graphic string data type, the encoding scheme and CCSID of the result are determined as follows:

- If the *expression* and *data-type* are both character, the encoding scheme of the result is the same as *expression*. For example, assume CHAR_COL is a character column in the following sample:

```
CAST(CHAR_COL AS VARCHAR(25))
```

The result of the CAST is a varying length string with the same encoding scheme as the input. The CCSID of the result is the appropriate CCSID for the encoding scheme and subtype of the result.

- If the *expression* and *data-type* are both graphic, the encoding scheme and CCSID of the result is the same as *expression*.
- If the result is string and the *expression* is datetime, the result CCSID is the appropriate CCSID of the *expression* encoding scheme and the result subtype is the appropriate subtype of the CCSID.
- If the result is character, the encoding scheme and CCSID of the result depends on the context in which the CAST specification is specified:
 - If the statement follows the rules that are described for type 1 statements in [Determining the encoding scheme and CCSID of a string \(Introduction to Db2 for z/OS\)](#), the CCSID is determined as follows:
 - If the statement references a table or view, the encoding scheme of that table or view determines the encoding scheme for the result.
 - Otherwise, the encoding scheme is EBCDIC, the default EBCDIC CCSID is used, and the subtype depends on the MIXED DECP value.

The CCSID of the result is the appropriate CCSID for the encoding scheme and subtype of the result.

- Otherwise, the CCSID of the result is the appropriate CCSID for the application encoding scheme and subtype of the result.
- If the result is graphic, the encoding scheme and the CCSID of the result depends on the context in which the CAST specification is specified:
 - If the statement follows the rules that are described for type 1 statements in [Determining the encoding scheme and CCSID of a string \(Introduction to Db2 for z/OS\)](#), the CCSID is determined as follows:
 - If the statement references a table or view, the encoding scheme of that table or view determines the encoding scheme for the result.
 - Otherwise, the default EBCDIC encoding scheme is used for the result.

The CCSID of the result is the appropriate CCSID for the encoding scheme and data type of the result.

- Otherwise, the CCSID of the result is the appropriate CCSID for the application encoding scheme of the result.
- Otherwise, the CCSID of the result depends on the context in which the CAST specification was specified.

- If the statement follows the rules that are described for type 1 in statements in [Determining the encoding scheme and CCSID of a string \(Introduction to Db2 for z/OS\)](#), the CCSID is determined as follows:

- If the statement references a table or view, the encoding scheme of that table or view determines the encoding scheme for the result.
- Otherwise, the default EBCDIC encoding scheme is used for the result.

The CCSID of the result is the appropriate CCSID for the encoding scheme and data type of the result.

Alternative syntax for casting distinct types

There is alternative syntax for casting a distinct type to its base data type and vice versa. Assume that a distinct type `D_MONEY` was defined with the following statement and column `MONEY` was defined with that data type.

```
CREATE TYPE D_MONEY AS DECIMAL(9,2);
```

`DECIMAL(MONEY)` is equivalent syntax to `CAST(MONEY AS DECIMAL(9,2))`. Both forms of the syntax use the cast function that Db2 generated when the distinct type `D_MONEY` was created to convert the distinct type to its source type of `DECIMAL(9,2)`.

However, it is possible that different cast functions might be chosen for the equivalent syntax forms because of the difference in function resolution, particularly the treatment on unqualified names. Although the process of function resolution is similar for both, in the `CAST` specification as described above, Db2 uses the schema name of the target data type to locate the function. Therefore, if an unqualified data type name is specified as the target data type, Db2 uses the SQL path to resolve the schema name of the distinct type and then searches for the function in that schema. In function notation, when an unqualified function name is specified, Db2 searches the schemas in the SQL path to find an appropriate function match, as described under [“Function resolution” on page 239](#). For example, assume that you defined the following distinct types, which implicitly gives you both `USAGE` authority on the distinct types and `EXECUTE` authority on the cast functions that are generated for them:

```
CREATE TYPE SCHEMA1.AGE AS DECIMAL(2,0);
  one of the generated cast functions is:
  FUNCTION SCHEMA1.AGE(SYSIBM.DECIMAL(2,0)) RETURNS SCHEMA1.AGE
CREATE TYPE SCHEMA2.AGE AS INTEGER;
  one of the generated cast functions is:
  FUNCTION SCHEMA2.AGE(SYSIBM.INTEGER) RETURNS SCHEMA2.AGE
```

If `STU_AGE`, an `INTEGER` host variable, is cast to the distinct type with either of the following statements and the SQL path is `SYSIBM, SCHEMA1, SCHEMA2`:

```
Syntax 1: CAST(:STU_AGE AS AGE);
Syntax 2: AGE(:STU_AGE);
```

different cast functions are chosen. For syntax 1, Db2 first resolves the schema name of distinct type `AGE` as `SCHEMA1` (the first schema in the path that contains a distinct type named `AGE` for which you have `EXECUTE` authority for the appropriate generated cast function). Then it looks for a suitable function in that schema and chooses `SCHEMA1.AGE` because the data type of `STU_AGE`, which is `INTEGER`, is promotable to the data type of the function argument, which is `DECIMAL(2,0)`. For syntax 2, Db2 searches all the schemas in the path for an appropriate function and chooses `SCHEMA2.AGE`. Db2 selects `SCHEMA2.AGE` over `SCHEMA1.AGE` because the data type of its argument (`INTEGER`) is an exact match for `STU_AGE` (`INTEGER`) and, therefore, a better match than the argument for `SCHEMA1.AGE`, which is `DECIMAL(2,0)`.

Syntax alternatives for time zones

: `TIMEZONE` can be specified as an alternative to `TIME_ZONE`.

Examples for CAST specification

Example 1

Assume that an application needs only the integer portion of the SALARY column, which is defined as DECIMAL(9,2) from the EMPLOYEE table. The following query for the employee number and the integer value of SALARY could be prepared.

```
SELECT EMPNO, CAST(SALARY AS INTEGER) FROM EMPLOYEE;
```

Example 2

Assume that two distinct types exist in schema SCHEMAX. Distinct type D_AGE was based on SMALLINT and is the data type for the AGE column in the PERSONNEL table. Distinct type D_YEAR was based on INTEGER and is the data type for the RETIRE_YEAR column in the same table. The following UPDATE statement could be prepared.

```
UPDATE PERSONNEL SET RETIRE_YEAR =?  
WHERE AGE = CAST( ? AS SCHEMAX.D_AGE);
```

The first parameter is an untyped parameter marker that has a data type of RETIRE_YEAR. However, the application will use an integer for the parameter marker. The parameter marker does not need to be cast because the SET is an assignment.

The second parameter marker is a typed parameter marker that is cast to the distinct type D_AGE. Casting the parameter marker satisfies the requirement that comparisons must be performed with compatible data types. The application will use the base data type, SMALLINT, to process the parameter marker.

Example 3

A CAST specification can be used to explicitly specify the data type of a parameter in a context where a parameter marker must be typed. In the following example, the CAST specification is used to tell Db2 to assume that the value that will be provided as input to the TIME function will be CHAR(20). See [“PREPARE statement” on page 2042](#) for a list of contexts when invoking functions where parameter markers can be untyped. For all other contexts when invoking a function, the CAST specification can be used to explicitly specify the type of a parameter marker.

```
INSERT INTO ADMF001.CASTSQLJ VALUES( TIME(CAST(? AS CHAR(20)) ) )
```

Example 4

Assume that an application wants to cast an EBCDIC string to Unicode UTF-8. The string contains the value 'Jürgen', which is 6 bytes in ASCII or EBCDIC and is 7 bytes in Unicode UTF-8. In the following query, the CAST specification is invoked with the *length* clause with CODEUNITS32 specified to ensure that the data is not truncated. (In this case, CODEUNITS16 could also be specified as the string unit.)

```
SELECT CAST('Jürgen' AS VARCHAR(6 CODEUNITS32) CCSID UNICODE)  
FROM SYSIBM.SYSDUMMY1;
```

For this query, the data is converted from EBCDIC to Unicode UTF-16, the length clause is applied, and then the UTF-16 result is converted to UTF-8.

Example 5

When a keyword is used for a special value that is expressed as a constant in a context where the keyword could be interpreted as a name, the CAST specification can be used to explicitly cast the special value to decimal-floating point. Assume that MYTAB contains columns named C1 and INFINITY, and that you want to reference the decimal float-point value for infinity in the same SQL statement. Use the CAST specification to explicitly cast INFINITY as a decimal floating-point value to ensure that it is not interpreted as the name of a column, parameter or variable:

```
SELECT INFINITY -- column named INFINITY  
FROM MYTAB  
WHERE C1 = CAST ('INFINITY' AS DECFLOAT) -- comparison is made with the
```



```
-- decimal floating-point
-- infinity value
```

Related concepts

Data types

Db2 supports both IBM-supplied data types (built-in data types) and user-defined data types (distinct types).

Casting between data types

There are many occasions when a value with a given data type needs to be *cast* (changed) to a different data type or to the same data type with a different length, precision, or scale.

Related reference

[MIXED DATA field \(MIXED DECP value\) \(Db2 Installation and Migration\)](#)

XMLCAST specification

The XMLCAST specification returns the first operand (the cast operand) converted to the type specified by *data-type*.



XMLCAST supports casts involving XML values, including conversions between non-XML data types and the XML data type. Either the type of the cast operand or the specified data type must be XML. If both the type of the cast operand and the target data type are XML, XMLCAST acts as a no-op.

expression

If the cast operand is an expression, the result is the argument value converted to the specified target data type. The expression or the target data type must be the XML data type. *expression* cannot be a host variable or parameter marker.

NULL

If the cast operand is the NULL keyword, the target data type must be the XML data type. The result is a null XML value.

parameter-marker

If the cast operand is a parameter marker, the target data type must be the XML data type. A parameter marker (specified as a question mark character) is normally considered to be an expression, but in this case because it has special meaning. When the cast operand is a *parameter-marker*, the data type that is specified represents the "promise" that the replacement value for the parameter marker will be assignable to the specified data type (using assignment rules). Such a parameter marker is considered to be a typed parameter marker, which is treated like any other typed value for the purpose of function resolution, a describe operation on a select list, or column assignment.

data-type

The name of an SQL data type. If the name is not qualified, the SQL path is used to perform data type resolution. *data-type* must not specify a distinct type. If a data type has associated attributes, such as length or precision and scale, these attributes should be included when specifying a value for *data-type*. CHAR defaults to a length of 1, and DECIMAL defaults to a precision of 5 and a scale of 0 if not specified. CLOB and DBCLOB default to a length of 1M. When the target data type is XML and the source data type is TIMESTAMP, trailing zeroes in the fractional seconds part of the value are not included in the result. Restrictions on the supported data types are based on the specified cast operand. The default encoding scheme for string data types is Unicode. The encoding scheme can be changed by specifying the CCSID clause.

Table 52. Supported conversions from Non-XML values to XML values

Source data type	Target data type: XML	Resulting XML schema type
DATE	Y	xs:date
TIME	Y	xs:time
TIMESTAMP(p) WITH TIME ZONE	Y	xs:dateTime

Examples

Example 1: Create a null XML value.

```
XMLCAST(NULL AS XML)
```

Example 2: Convert a value extracted from an XMLQUERY expression into an INTEGER:

```
XMLCAST(XMLQUERY('/PRODUCT/QUANTITY'  
PASSING xmlcol) AS INTEGER)
```

Example 3: Convert a value extracted from an XMLQUERY expression into a varying-length character string:

```
XMLCAST(XMLQUERY('/PRODUCT/NAME'  
PASSING xmlcol) AS VARCHAR(20))
```

Note that in the above two examples, if the XMLQUERY returns a sequence of more than one node, the XMLCAST specification will return an error.

Example 4: Convert a value extracted from an SQL scalar subquery into an XML value:

```
XMLCAST((SELECT quantity FROM product AS p  
WHERE p.id = 1077) AS XML)
```

Array element specification

The array element specification returns the element from an array specified by *array-index*.

► *array-expression* — [*array-index*] ◄

array-expression

Specifies an SQL variable, SQL parameter, or global variable of an array type, or a CAST specification of a parameter marker to an array type.

[*array-index*]

An expression that specifies the array index of the element that is to be extracted from the array. An array index value for an ordinary array must be castable to INTEGER. The array index value must be between 1 and the cardinality of the array. An array index value for an associative array must be castable to the data type of the index for the array type. The array index value must represent an element that exists in the array. If the index value is a string that is longer than the index data type, the value is truncated, a warning is issued, and processing continues with the truncated value.

array-index must not be:

- An expression that references the CURRENT DATE, CURRENT TIME, or CURRENT TIMESTAMP special register
- A nondeterministic function
- A function that is defined with EXTERNAL ACTION
- A function that is defined with MODIFIES SQL DATA

- A sequence expression

In EBCDIC code pages, X'BBBB' is normally treated as a concatenation operator. Because this sequence of characters is a pair of right brackets characters (']']) in some EBCDIC code pages, it is not treated as a concatenation operator when used inside of an array-index expression.

The data type of the result is the data type that is specified for the array on the CREATE TYPE (array) statement. If *array-index* is null, or the array is null, the null value is returned.

If the array element is character or graphic data, the CCSID of the result is the CCSID of the array elements of the array type. If the array element is datetime data, the CCSID of the result is 1208.

Examples

Example 1: Suppose that PHONE_NUMBERS is an array variable that is defined as an array type. The array type is defined as an ordinary array of CHAR(10) elements. Also suppose that INT_VAR is an integer variable. The following assignment statements demonstrate how an index for an array element can be specified.

Set the first element of an array to NULL:

```
SET PHONE_NUMBERS[1] = NULL;
```

Set the third element to the value '4164789683':

```
SET PHONE_NUMBERS[3] = '4164789683';
```

Set an array element to '4164788888', and specify the array index with the variable INT_VAR:

```
SET PHONE_NUMBERS[INT_VAR] = '4164788888';
```

Set an array element to '4164783322', and specify the array index with the expression INT_VAR+5:

```
SET PHONE_NUMBERS[INT_VAR + 5] = '4164783322';
```

Array constructor

An array constructor returns an ordinary array. An array constructor is specified by a list of expressions or a fullselect.

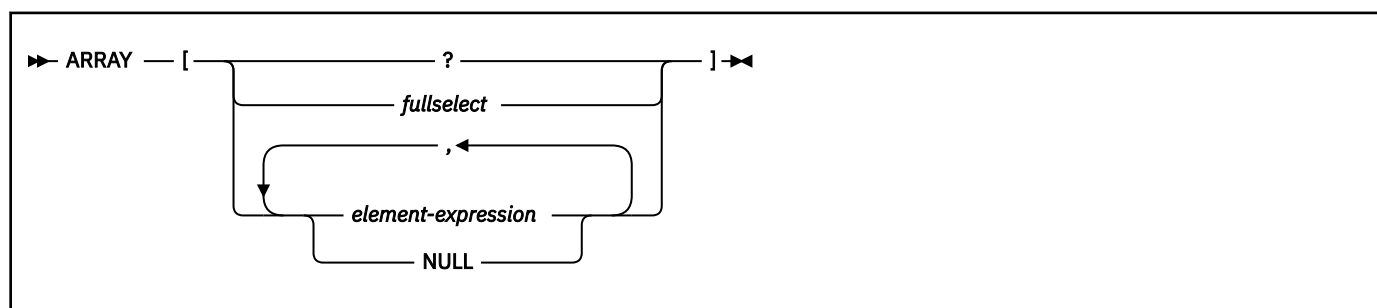

Authorization

No specific authorizations are required to reference an array constructor within an SQL statement. However, for the statement execution to be successful, all other authorization requirements for the statement must be satisfied.

fullselect

A fullselect that returns a single column. The data type of the column must be a data type that can be specified in a CREATE TYPE (array) statement as the data type of an array element. The values that are returned by the fullselect are the elements of the array. The cardinality of the array is equal to the number of rows that are returned by the fullselect. An ORDER BY clause in the fullselect can

be used to specify the order among the elements of the array. Otherwise, the order is undefined. The data type of the elements of the resulting array is the same as the data type of the result column of the fullselect.

element-expression

An expression that defines the value of an element in the array. The expression must return a value with a data type that can be specified in a CREATE TYPE (array) statement as the data type of an array element. The cardinality of the array is equal to the number of element expressions. The first element expression is assigned to the array element with array index 1. The second element expression is assigned to the array element with array index 2, and so on. All element expressions must have compatible data types. The data type of the elements of the resulting array are determined based on the rules that are described in [“Rules for result data types”](#) on page 166.

NULL

Specifies the null value.

If no value is specified within the brackets, the result is an empty array.

An array constructor cannot be specified in an inline SQL function, and can only be specified in the following specific contexts:

- As a source value for a SET *assignment-statement* statement or an SQL PL *assignment-statement* statement
- As the value that is to be returned in a RETURN statement of a user-defined scalar function

An array constructor cannot be used to construct an associative array. An associative array can be constructed only by assigning values to individual array elements.

Examples

Example 1: Suppose that the array variable RECENT_CALLS has the array type PHONENUMBERS. Assign an array of fixed numbers to RECENT_CALLS.

```
SET RECENT_CALLS = ARRAY[9055553907, 4165554213, 4085553678];
```

Example 2: Suppose that the array variable DEPT_PHONES has the array type PHONENUMBERS. Assign array phone numbers that are retrieved from the DEPARTMENT_INFO table to DEPT_PHONES.

```
SET DEPT_PHONES =  
  ARRAY[SELECT DECIMAL(AREA_CODE CONCAT '555' CONCAT EXTENSION,16)  
        FROM DEPARTMENT_INFO  
        WHERE DEPTID = 624];
```

OLAP specifications

Online analytical processing (OLAP) specifications provide the ability to return ranking, row numbering, and aggregation information as a scalar value in the result of a query. An OLAP specification can be included in an expression, in a *select-list*, or in the ORDER BY clause of a *select-statement*. The query result to which the OLAP specifications is applied is the result table of the innermost subselect that includes the OLAP specification.

Syntax for OLAP specifications



ordered-OLAP-specification

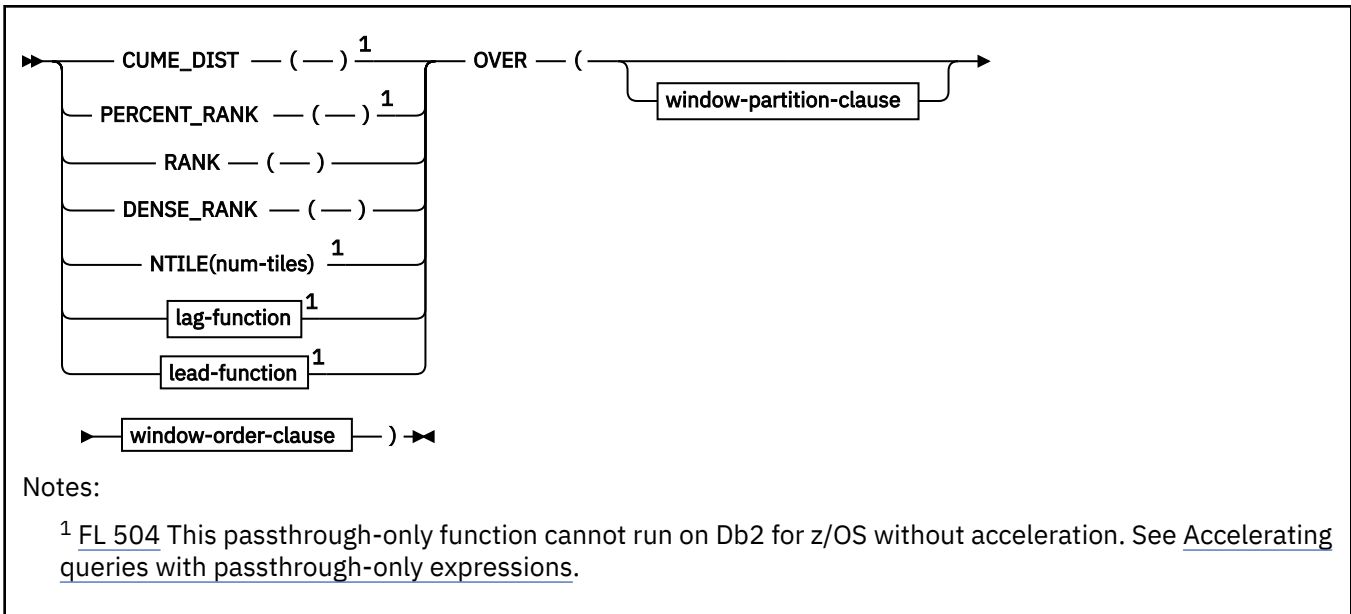

lag-function

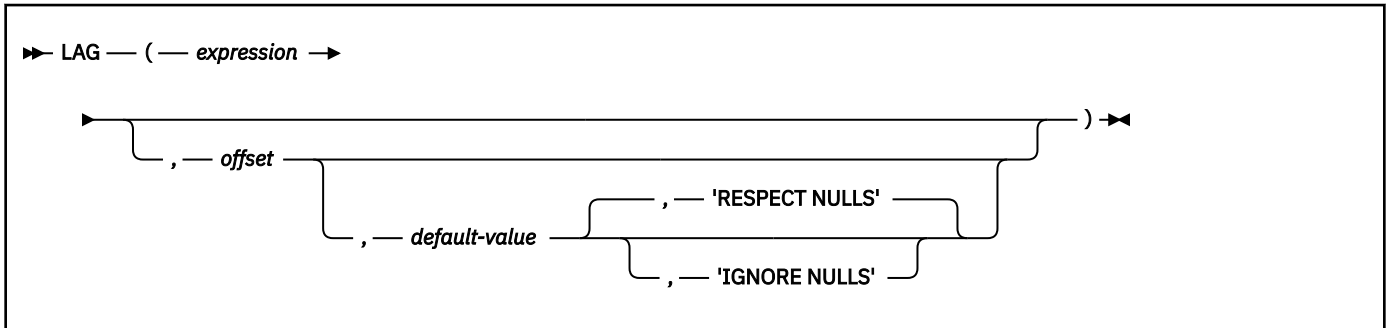

lead-function

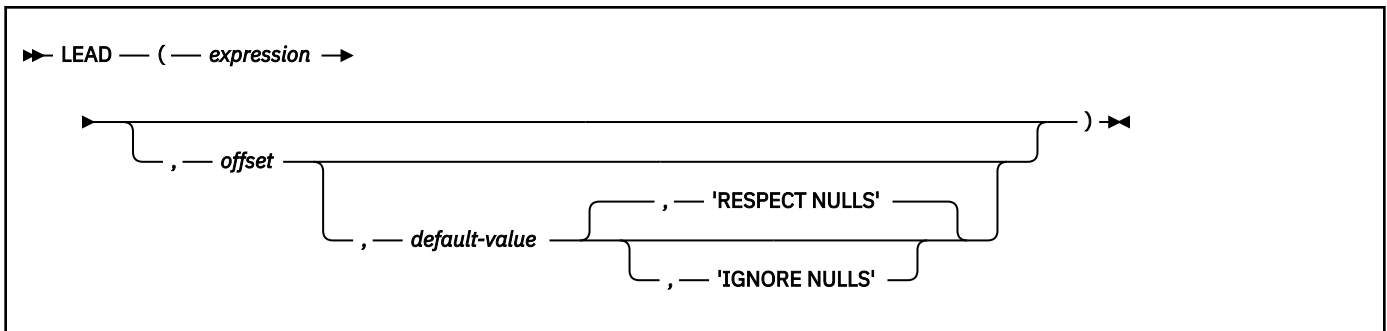

window-partition-clause



window-order-clause

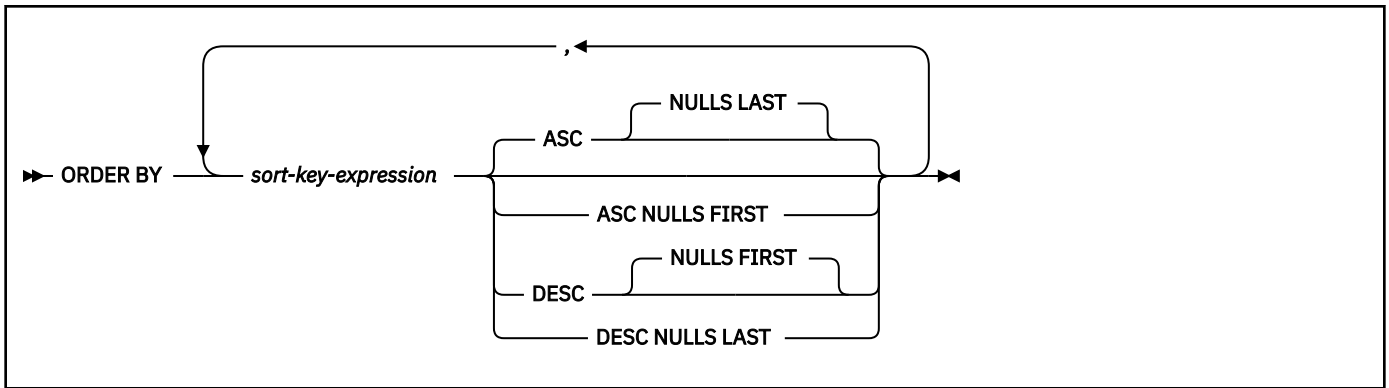

numbering-specification

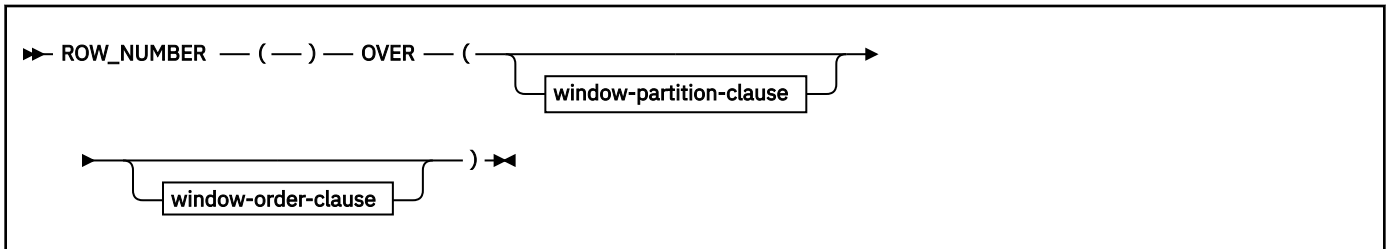

aggregation-specification

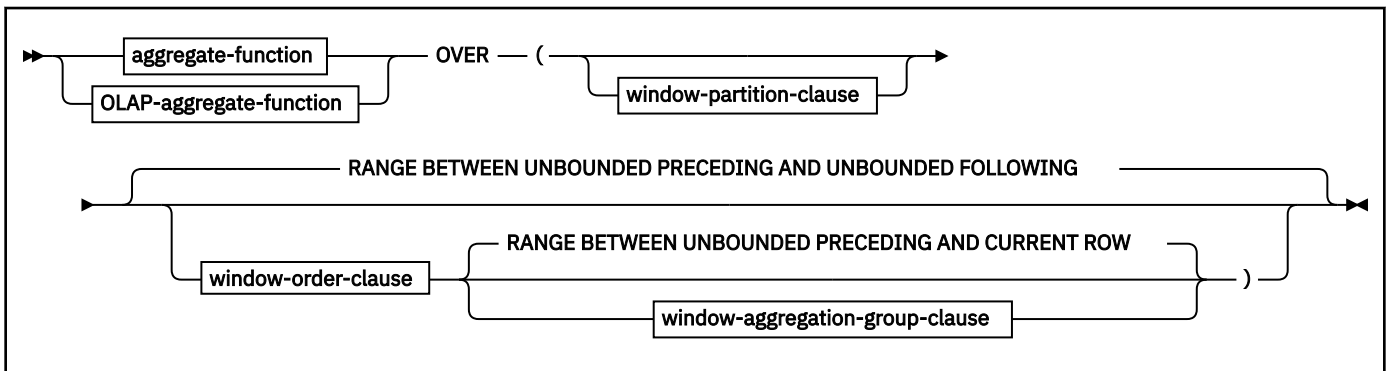

aggregate-function

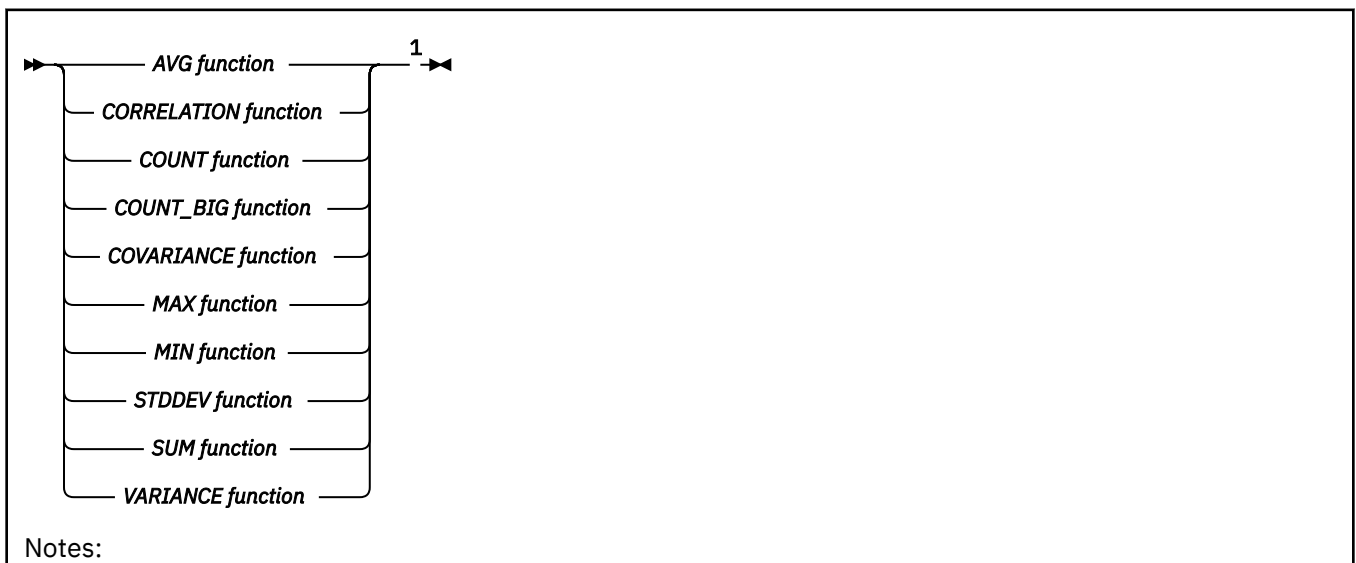

¹ You cannot specify DISTINCT or ALL for an aggregate function that is included in an aggregation-specification.

OLAP-aggregate-function

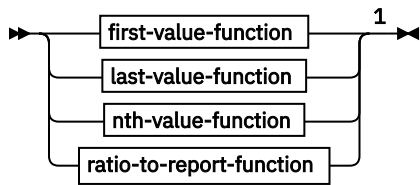

Notes:

¹ FL 504 These passthrough-only functions cannot run on Db2 for z/OS without acceleration. See [Accelerating queries with passthrough-only expressions](#).

first-value-function

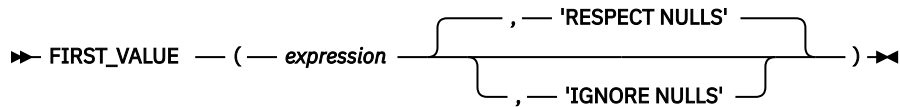

last-value-function

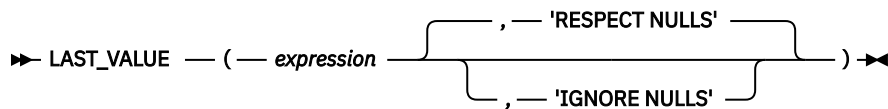

nth-value-function



ratio-to-report-function

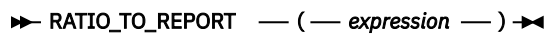

window-aggregation-group-clause

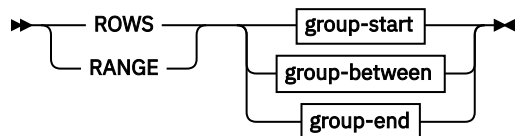

group-start



group-between

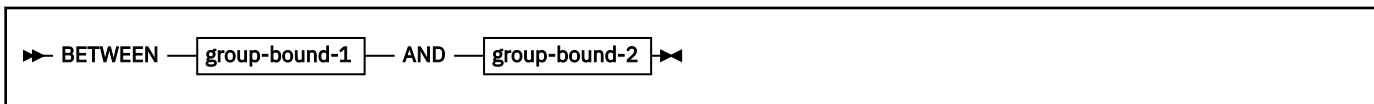

group-bound-1



group-bound-2



group-end

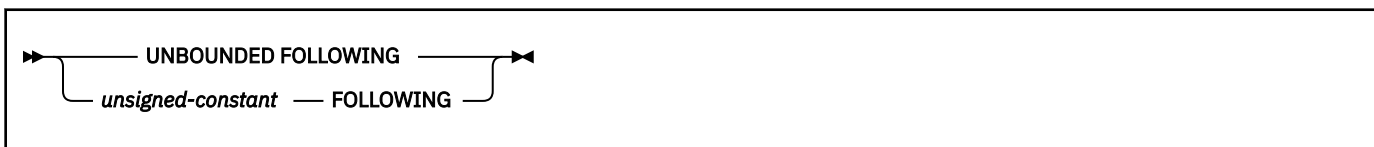

RANK, DENSE_RANK, and ROW_NUMBER are sometimes called window functions.

An OLAP specification is not valid in a WHERE, VALUES, GROUP BY, HAVING, or SET clause. An OLAP specification cannot be used as an argument of an aggregate function.

When invoking an OLAP specification, a window is specified that defines the rows over which the function is applied and in which order.

The result of a RANK, DENSE_RANK, or ROW_NUMBER specification is BIGINT. The result cannot be null.

CUME_DIST

FL 504 Returns a cumulative distribution of a row within an OLAP window, expressed as a value in the range of 0.0–1.0. The result is computed by dividing the number of rows preceding or equivalent to the current row in the OLAP window by the number of rows in the OLAP window.

The data type of the result is DECFLOAT(34). The result cannot be NULL.

Passthrough-only expression: This function is passthrough-only and cannot run on Db2 for z/OS without acceleration. For information about invoking this function, see [Accelerating queries with passthrough-only expressions](#).

PERCENT_RANK

FL 504 Returns a relative percentile rank of a row within an OLAP window, expressed as a value in the range 0.0–1.0. When the number of rows in the OLAP window is greater than 1, the result is computed

by dividing the RANK of the current row in the OLAP window minus 1 by the number of rows in the OLAP window minus 1. Otherwise, the result is 0.0.

Passthrough-only expression: This function is passthrough-only and cannot run on Db2 for z/OS without acceleration. For information about invoking this function, see [Accelerating queries with passthrough-only expressions](#).

RANK or DENSE_RANK

Specifies that the ordinal rank of a row within the specified window is computed. Rows that are not distinct with respect to the ordering within the specified window are assigned the same rank. The results of the ranking can be defined with or without gaps in the numbers that result from duplicate values.

RANK

Specifies that the rank of a row is defined as 1 plus the number of rows that strictly precede the row. Thus, if two or more rows are not distinct with respect to the ordering, there will be one or more gaps in the sequential rank numbering.

DENSE_RANK

Specifies that the rank of a row is defined as 1 plus the number of preceding rows that are distinct with respect to the ordering. Therefore, there will be no gaps in the sequential rank numbering.

NTILE

FL 504 Returns the quantile rank of a row.

Passthrough-only expression: This function is passthrough-only and cannot run on Db2 for z/OS without acceleration. For information about invoking this function, see [Accelerating queries with passthrough-only expressions](#).

num-tiles

An expression that specifies the number of quantiles. The expression must return a value that is a built-in numeric data type, CHAR, or VARCHAR data type. In a Unicode database, the expression can also be a GRAPHIC or VARGRAPHIC data type. CHAR, VARCHAR, GRAPHIC, and VARGRAPHIC are supported by using implicit casting. If the expression is not a SMALLINT, INTEGER, or BIGINT, it is cast to BIGINT before the function is evaluated. The value must be greater than 0. The expression must be a constant, a variable, or a cast of a constant or variable.

The data type of the result of NTILE is the same data type as the data type of *num-tiles* after any implicit casting. If the argument can be null, the result can be null. If the argument is null, the result is the null value.

The NTILE function computes the quantile rank of a row by dividing the ordered rows within the OLAP window into *num-tiles* quantiles and returns a value between 1 and $\text{MIN}(n, \text{num-tiles})$, where n is the number of rows within the OLAP window. If n is evenly divisible by *num-tiles*, the rows in the OLAP window are grouped into *num-tiles* quantiles, each containing $(n / \text{num-tiles})$ rows. Otherwise, each of the quantiles 1 through $\text{MOD}(n, \text{num-tiles})$ is assigned $(n / \text{num-tiles} + 1)$ rows, and each of the quantiles $(\text{MOD}(n, \text{num-tiles}) + 1)$ through *num-tiles* is assigned $(n / \text{num-tiles})$ rows. The result is the quantile rank which is associated with the current row.

Equivalent sort keys are not considered when rows are divided into quantiles. Rows with equivalent sort keys can be assigned to different quantiles based on the non-deterministic order of these sort keys. Therefore, NTILE is a non-deterministic function.

LAG

FL 504 Returns the expression value for the row at *offset* rows before the current row. The *offset* must be a positive integer constant. An *offset* value of 0 indicates the current row. If a window-partition-clause is specified, *offset* indicates *offset* rows before the current row and within the current partition. If *offset* is not specified, the value 1 is used. If *default-value* (which can be an expression) is specified, it will be returned if the *offset* goes beyond the scope of the current partition. Otherwise, the null value is returned. If 'IGNORE NULLS' is specified, all rows for which the expression value is the null value are not considered in the calculation. If 'IGNORE NULLS' is specified and all rows are null, *default-value* (or the null value if *default-value* was not specified) is returned.

Passthrough-only expression: This function is passthrough-only and cannot run on Db2 for z/OS without acceleration. For information about invoking this function, see [Accelerating queries with passthrough-only expressions](#).

LEAD

FL 504 Returns the expression value for the row at *offset* rows after the current row. The *offset* must be a positive integer constant. An *offset* value of 0 indicates the current row. If a window-partition-clause is specified, *offset* indicates *offset* rows after the current row and within the current partition. If *offset* is not specified, the value 1 is used. If *default-value* (which can be an expression) is specified, it will be returned if the *offset* goes beyond the scope of the current partition. Otherwise, the null value is returned. If 'IGNORE NULLS' is specified, all rows for which the expression value is the null value are not considered in the calculation. If 'IGNORE NULLS' is specified and all rows are null, *default-value* (or the null value if *default-value* was not specified) is returned.

Passthrough-only expression: This function is passthrough-only and cannot run on Db2 for z/OS without acceleration. For information about invoking this function, see [Accelerating queries with passthrough-only expressions](#).

ROW_NUMBER

Specifies that a sequential row number is computed for the row that is defined by the ordering, starting with 1 for the first row. If the ORDER BY clause is not specified in the window, the row numbers are assigned to the rows in an arbitrary order, as the rows are returned (not according to any ORDER BY clause in the *select-statement*).

PARTITION BY *partitioning-expression*,...

Defines the partition within which the OLAP operation is applied. A *partitioning-expression* is an expression that is used in defining the partitioning of the result table. Each column name that is referenced in a *partitioning-expression* must unambiguously reference a column of the result table of the subselect that contains the OLAP specification. A *partitioning-expression* cannot include a *scalar-fullselect* an XMLQUERY or XMLEXISTS expression or any function that is not deterministic or has an external action.

ORDER BY *sort-key-expression*,...

Defines the ordering of rows within a partition that is used to determine the value of the OLAP specification. It does not define the ordering of the result table.

sort-key-expression

Specifies an expression to use in defining the ordering of the rows within a window partition. Each column name that is referenced in a *sort-key-expression* must unambiguously reference a column of the result table of the subselect, including the OLAP specification. A *sort-key-expression* cannot include a scalar fullselect, an XMLQUERY or XMLEXISTS expression, or any function that is not deterministic or that has an external action.

ASC

Specifies that the values of *sort-key-expression* are used in ascending order.

DESC

Specifies that the values of *sort-key-expression* are used in descending order.

NULLS FIRST

Specifies that the window ordering considers null values before all non-null values in the sort order.

NULLS LAST

Specifies that the window ordering considers null values after all non-null values in the sort order.

FIRST_VALUE

FL 504 Returns the expression value for the first row in an OLAP window. If 'IGNORE NULLS' is specified, all rows for which the expression value is the null value are not considered in the calculation. If 'IGNORE NULLS' is specified and all values in the OLAP window are null, FIRST_VALUE returns the null value.

Passthrough-only expression: This function is passthrough-only and cannot run on Db2 for z/OS without acceleration. For information about invoking this function, see [Accelerating queries with passthrough-only expressions](#).

LAST_VALUE

FL 504 Returns the expression value for the last row in an OLAP window. If 'IGNORE NULLS' is specified, all rows for which the expression value is the null value are not considered in the calculation. If 'IGNORE NULLS' is specified and all values in the OLAP window are null, LAST_VALUE returns the null value.

Passthrough-only expression: This function is passthrough-only and cannot run on Db2 for z/OS without acceleration. For information about invoking this function, see [Accelerating queries with passthrough-only expressions](#).

NTH_VALUE

FL 504 Returns the expression value for the *n*th-row row in an OLAP window.

Passthrough-only expression: This function is passthrough-only and cannot run on Db2 for z/OS without acceleration. For information about invoking this function, see [Accelerating queries with passthrough-only expressions](#).

expression

An expression that specifies the current row in an OLAP window. The expression must return a value that is a built-in data type.

nth-row

An expression that specifies which row of the OLAP window to return. The expression must return a value that is a built-in numeric data type, a CHAR, or a VARCHAR data type. In a Unicode database, the expression can also be a GRAPHIC or VARGRAPHIC data type. CHAR, VARCHAR, GRAPHIC, and VARGRAPHIC are supported using implicit casting. If the expression is not a SMALLINT, INTEGER, or BIGINT, it is cast to BIGINT before the function is evaluated. The value must be greater than 0. The expression must be a constant, a variable, or a cast of a constant or variable.

Db2 for z/OS does not support the FROM FIRST, FROM LAST, RESPECT NULLS, and IGNORE NULLS keywords for this function. Omitting these keywords in Db2 for Linux®, UNIX, and Windows results in the default behavior FROM FIRST RESPECT NULLS.

RATIO_TO_REPORT

FL 504 Returns the ratio of an argument to the sum of the arguments in an OLAP partition. The division is always performed using DECFLOAT(34). The result data type is DECFLOAT(34). If the argument can be null, the result can be null; if the argument is null, the result is the null value.

Passthrough-only expression: This function is passthrough-only and cannot run on Db2 for z/OS without acceleration. For information about invoking this function, see [Accelerating queries with passthrough-only expressions](#).

window-aggregation-group-clause

The aggregation group of a given row is a set of rows that is defined in relation to the given row (in the ordering of the rows in the partition of the given row). *window-aggregation-group-clause* specifies the aggregation group. If this clause is not specified and a *window-order-clause* is also not specified, the aggregation group consists of all rows of the window partition. The aggregation group of all rows of the window partition can be explicitly specified using the RANGE or ROWS clauses.

If *window-order-clause* is specified, but *window-aggregation-group-clause* is not specified, the window aggregation group consists of all rows that precede a given row of the partition of the given row or all rows that are peers of the given row in the window ordering of the window partition that is defined by the *window-order-clause*

ROW

Specifies that the aggregation group is defined by counting rows.

RANGE

Specifies that the aggregation group is defined by an offset from a sort key.

group-start

Specifies the starting point for the aggregation group. The aggregation group end is the CURRENT ROW. Specifying *group-start* is equivalent to specifying *group-between* as BETWEEN *group-start* AND CURRENT ROW.

group-between

Specifies that the aggregation group start and end based on either ROWS or RANGE.

group-end

Specifies the ending point for the aggregation group. The aggregation group start is the CURRENT ROW. Specifying *group-end* is equivalent to specifying *group-between* as BETWEEN CURRENT ROW AND *group-end*.

UNBOUNDED PRECEDING

Specifies that the entire partition that precedes the current row is included in the aggregation group. This can be specified with either the ROWS or RANGE clauses. Including the entire partition that precedes the current row can also be specified with multiple *sort-key-expressions* in the *window-order-clause*.

UNBOUNDED FOLLOWING

Specifies that the entire partition that follows the current row is included in the aggregation group. This can be specified with either the ROWS or RANGE clauses. Including the entire partition that follows the current row can also be specified with multiple *sort-key-expressions* in the *window-order-clause*.

CURRENT ROW

Specifies that the aggregation group starts or ends based on the current row. If ROWS is specified, the current row is the aggregation group boundary. If RANGE is specified, the aggregation group boundary includes the set of rows with the values specified for the *sort-key-expression* as the current row. This clause cannot be specified in *group-bound-2* if *group-bound-1* specifies *unsigned-constant* FOLLOWING.

unsigned-constant PRECEDING

Specifies either the range or the number of rows that precede the current row. If ROWS is specified, *unsigned-constant* must be zero or a positive integer that indicates a number of rows. If RANGE is specified, the data type of *unsigned-constant* must be comparable to the data type of the *sort-key-expression* of the *window-order-clause*. Only one *sort-key-expression* is allowed, and the data type of *sort-key-expression* must allow subtraction. This clause cannot be specified in *group-bound-2* if *group-bound-1* is CURRENT ROW or *unsigned-constant* FOLLOWING.

unsigned-constant FOLLOWING

Specifies either the range or the number of rows that follow the current row. If ROWS is specified, *unsigned-constant* must be zero or a positive integer that indicates a number of rows. If RANGE is specified, the data type of *unsigned-constant* must be comparable to the data type of the *sort-key-expression* of the *window-order-clause*. Only one *sort-key-expression* is allowed, and the data type of *sort-key-expression* must allow addition.

Notes for OLAP Specification

Using a column mask with an OLAP specification: If a column mask is used to mask the column values in the final result table and an OLAP specification is referenced in the select list that is used to derive the final result table, the column mask cannot be applied to the column that is specified in the *partitioning-expression* or the *sort-key-expression* in the OLAP specification.

Syntax alternatives and synonyms: For compatibility, the keywords DENSERANK and ROWNUMBER can be used as synonyms for DENSE_RANK and ROW_NUMBER respectively.

Examples for OLAP specification

Example 1: Display the ranking of employees that have a total salary of more than \$30,000, in order by last name:

```
SELECT EMPNO, LASTNAME, FIRSTNAME, SALARY+BONUS AS TOTAL_SALARY,
       RANK() OVER(ORDER BY SALARY+BONUS DESC) AS RANK_SALARY
FROM EMP WHERE SALARY+BONUS > 30000
ORDER BY LASTNAME;
```

If the result is to be ordered by rank, ORDER BY LASTNAME would be replaced with ORDER BY RANK_SALARY.

Example 2: Rank the departments according to their average total salary:

```
SELECT WORKDEPT, AVG(SALARY+BONUS) AS AVG_TOTAL_SALARY,  
       RANK() OVER(ORDER BY AVG(SALARY+BONUS) DESC) AS RANK_AVG_SAL  
FROM EMP  
GROUP BY WORKDEPT  
ORDER BY RANK_AVG_SAL;
```

Example 3: Rank the departments according to their education level. Having multiple employees with the same rank in the department should not increase the next ranking value:

```
SELECT WORKDEPT, EMPNO, LASTNAME, FIRSTNAME, EDLEVEL,  
       DENSE_RANK() OVER  
       (PARTITION BY WORKDEPT ORDER BY EDLEVEL DESC) AS RANK_EDLEVEL  
FROM EMP  
ORDER BY WORKDEPT, LASTNAME;
```

Example 4: Provide row numbers in the results of a query:

```
SELECT ROW_NUMBER() OVER(ORDER BY WORKDEPT, LASTNAME) AS NUMBER,  
       LASTNAME, SALARY  
FROM EMP  
ORDER BY WORKDEPT, LASTNAME;
```

Example 5: List the top five wage earners:

```
SELECT EMPNO, LASTNAME, FIRSTNAME, TOTAL_SALARY, RANK_SALARY  
FROM (SELECT EMPNO, LASTNAME, FIRSTNAME, SALARY+BONUS AS TOTAL_SALARY,  
       RANK() OVER (ORDER BY SALARY+BONUS DESC) AS RANK_SALARY  
FROM EMP) AS RANKED_EMPLOYEE  
WHERE RANK_SALARY < 6  
ORDER BY RANK_SALARY;
```

A nested table expression is used to first compute the result, including the ranking, before the rank can be used in the WHERE clause. A common table expression could also have been used.

Example 6: The following example is used to calculate the 30 day moving average for the stocks 'ABC' and 'XYZ' during 2005:

```
CREATE VIEW V1 AS  
  SELECT SYMBOL, TRADINGDATE,  
         AVG(CLOSINGPRICE) OVER (PARTITION BY SYMBOL  
                                ORDER BY TRADINGDATE  
                                ROWS BETWEEN 29 PRECEDING AND CURRENT  
ROW)  
  FROM DAILYSTOCKDATA  
  WHERE SYMBOL IN ('ABC', 'XYZ')  
         AND TRADINGDATE BETWEEN DATE('2005-01-01') - 2 MONTHS AND '2005-12-31';  
  
SELECT SYMBOL, TRADINGDATE, MOVINGAVG30DAY  
FROM V1  
WHERE TRADINGDATE BETWEEN '2005-01-01' AND '2005-12-31'  
ORDER BY SYMBOL, TRADINGDATE;
```

Example 7: Calculate which quartile (4-quartiles) each employee's salary is in.

```
SELECT EMPNO, SALARY, NTILE(4) OVER  
       (ORDER BY SALARY) AS QUARTILE  
FROM EMPLOYEE  
ORDER BY SALARY
```

The result set is:

EMPNO	SALARY	QUARTILE
200340	31840.00	1
000290	35340.00	1
200330	35370.00	1
000310	35900.00	1
200310	35900.00	1
000280	36250.00	1
000270	37380.00	1
000300	37750.00	1

200240	37760.00	1
200120	39250.00	1
000320	39950.00	1
000230	42180.00	2
000340	43840.00	2
000170	44680.00	2
000330	45370.00	2
200280	46250.00	2
200010	46500.00	2
000260	47250.00	2
000240	48760.00	2
000250	49180.00	2
000120	49250.00	2
000220	49840.00	2
000190	50450.00	3
000180	51340.00	3
000150	55280.00	3
000200	57740.00	3
000160	62250.00	3
200170	64680.00	3
000110	66500.00	3
000210	68270.00	3
000140	68420.00	3
200140	68420.00	3
200220	69840.00	4
000060	72250.00	4
000130	73800.00	4
000050	80175.00	4
000100	86150.00	4
000090	89750.00	4
000020	94250.00	4
000070	96170.00	4
000030	98250.00	4
000010	152750.00	4

42 record(s) selected.

Example 8: The query in the following example divides the rows into 3 buckets, grouping them by maximum salary. The maximum salary is included to show what values go into each bucket:

```
SELECT NTILE(3) OVER (ORDER BY MAX_SALARY) AS Bucket,
MAX_SALARY FROM GOSALESDW.EMP_POSITION_DIM;
```

A portion of the output from the query is in the following table:

Table 53. Example output

BUCKET	MAX_SALARY
1	0.00
...	...
1	35000.00
2	5000.00
...	...
2	12000.00
3	13000.00
...	...
3	301500.00

ROW CHANGE expression

A ROW CHANGE expression returns a token or a timestamp that represents the last change to a row.

ROW CHANGE expression

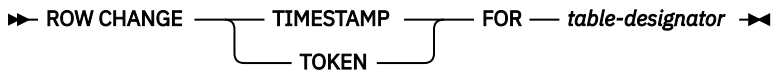

TIMESTAMP

Specifies that a timestamp is returned that represents the last time when a row was changed. If the row has not been changed, the result is the time that the initial value was inserted.

TOKEN

Specifies that a token that is a BIGINT value is returned that represents a relative point in the modification sequence of a row. If the row has not been changed, the result is a token that represents when the initial value was inserted.

FOR *table-designator*

Identifies the table in which the expression is referenced. *table-designator* must be an exposed name that uniquely identifies a base table, a view, or a nested table expression of a subselect. If *table-designator* identifies a view or a nested table expression, the ROW CHANGE expression returns the TIMESTAMP or TOKEN of the base table of the view or the nested table expression. The view or nested table expression must contain only one base table in its outer subselect.

table-designator must not identify:

- An alias, a synonym, or a materialized view
- A nested table expression that is materialized
- A system-period temporal table, if the system time sensitive bind option is set to YES
- An archive-enabled table, if one of the following conditions is true:
 - For a static statement, the archive sensitive option in effect is YES.
 - For a dynamic statement, the archive sensitive option in effect is YES, and the GET_ARCHIVE built-in global variable is set to 'Y'.

The result can be null. The ROW CHANGE TIMESTAMP and ROW CHANGE TOKEN expressions are not deterministic.

Notes

Tables without a row change timestamp column:

For tables without a row change timestamp column, the ROW CHANGE TIMESTAMP expression returns a timestamp value that reflects changes made to the page instead of to the row. This timestamp value indicates that at least one row in the page has changed, but does not indicate which row, or even how many rows, have changed. The ROW CHANGE TIMESTAMP expression might indicate that a row has changed, however, the change might be for other rows in the same page.

In a data sharing environment, the returned timestamp value is based on the LRSN value of the page and reflects the most recent time the page was modified.

In a non-data sharing environment, the returned timestamp value is based on the RBA value of the page. In a non-data sharing environment, changes made to the same page within a half hour of each other might be indistinguishable. For example, issuing the following SELECT statements in a non-data sharing environment will possibly return the same value, even though the row was changed between the two SELECT statements:

```
CREATE TABLE T1 (C1 INTEGER NOT NULL);
INSERT INTO T1 VALUES (1);
SELECT ROW CHANGE TIMESTAMP FOR T1 FROM T1;
```

```
UPDATE T1 SET C1 = 2 WHERE C1 = 1;  
SELECT ROW CHANGE TIMESTAMP FOR T1 FROM T1;
```

Example 1:

The following example returns all the rows that have been changed in the last day:

```
SELECT * FROM ORDERS  
WHERE ROW CHANGE TIMESTAMP FOR ORDERS >  
CURRENT TIMESTAMP - 24 HOURS;
```

Example 2:

The following example returns a timestamp value that corresponds to the most recent change to each row from the EMP table for those employees in department 20:

```
SELECT ROW CHANGE TIMESTAMP FOR EMP  
FROM EMP WHERE DEPTNO = 20;
```

Example 3:

The following example returns a BIGINT value that corresponds to a relative point in the modification sequence of EMP with employee number '3500':

```
SELECT ROW CHANGE TOKEN FOR EMP  
FROM EMP WHERE EMPNO = '3500';
```

Sequence reference

A sequence is referenced by using the NEXT VALUE and PREVIOUS VALUE expressions specifying the name of the sequence.

sequence-reference

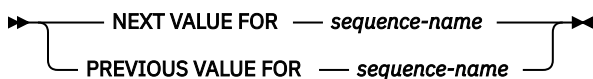

NEXT VALUE FOR*sequence-name*

A NEXT VALUE expression generates and returns the next value for a specified sequence. A new value is generated for a sequence when a NEXT VALUE expression specifies the name of the sequence. However, if there are multiple instances of a NEXT VALUE expression specifying the same sequence name within a query, the sequence value is incremented only once for each row of the result, and all instances of NEXT VALUE return the same value for a row of the result. The NEXT VALUE expression is a not deterministic with external actions since it causes the sequence value to be incremented.

When the next value for the sequence is generated, if the maximum value for an ascending sequence or the minimum value for a descending sequence of the logical range of the sequence is exceeded and the NO CYCLE option is in effect, then an error occurs. To avoid this error, either alter the sequence attributes to extend the range of value or to enable cycles for the sequence or drop and re-create the sequence with a different data type that allows a larger range of values.

The data type and length attributes of the result of a NEXT VALUE expression are the same as for the specified sequence. The result cannot be null.

PREVIOUS VALUE FOR*sequence-name*

A PREVIOUS VALUE expression returns the most recently generated value for the specified sequence for a previous statement within the current application process. This value can be repeatedly referenced by using PREVIOUS VALUE expressions to specify the name of the sequence. There can be multiple instances of PREVIOUS VALUE expressions specifying the same sequence name within a single statement and they all return the same value.

A PREVIOUS VALUE expression can be used only if a NEXT VALUE expression specifying the same sequence name has already been referenced in the current application process.

The data type and length attributes of the result of a PREVIOUS VALUE expression are the same as for the specified sequence. The result cannot be null.

sequence-name

Identifies the sequence that is to be referenced. The combination of name and the implicit or explicit schema name must identify an existing sequence at the current server. *sequence-name* must not be the name of an internal sequence object that is generated by Db2 for an identity column. The contents of the SQL PATH are not used to determine the implicit qualifier of a sequence name.

Notes

Authorization:

If a sequence is referenced in a statement, the privileges that are held by the authorization ID of the statement must include at least one of the following:

- For the sequence identified in the statement:
 - The USAGE privilege on the sequence
 - Ownership of the sequence
- SYSADM or DATAACCESS authority

Generating values with NEXT VALUE:

When a value is generated for a sequence, that value is consumed, and the next time that a value is requested, a new value will be generated. This is true even when the statement containing the NEXT VALUE expression fails or is rolled back.

Scope of NEXT VALUE and PREVIOUS VALUE:

The value of PREVIOUS VALUE cannot be directly set and is a result of executing the NEXT VALUE expression for the sequence. The value of PREVIOUS VALUE persists until the next value is generated for the sequence in the current session, the sequence is dropped or altered, or the application session ends.

The value for the sequence cannot persist across a COMMIT or ROLLBACK for a local or remote application if, after the COMMIT or ROLLBACK, the Db2 application thread or server thread is assigned to another user or Db2 connection because of some form of thread reuse, re-signon, or connection pooling is in effect. For example, this can occur for CICS-Db2 applications and for client applications or middleware products that save the state of a session and then restore the state of a session for subsequent processing because they are not able to restore the NEXT or PREVIOUS VALUES for a sequence. In these situations, the availability of the value for a sequence should only be relied on until the end of the transaction. Examples of where this type of situation can occur include applications that do the following:

- issue an EXEC CICS SYNCPOINT command
- use XA protocols
- use connection pooling
- use the connection concentrator
- use Sysplex workload balancing
- connect to a z/OS server that uses DDF inactive threads

When there is a need to preserve the value that is associated with NEXT VALUE or PREVIOUS VALUE expressions across transaction boundaries for local or distributed applications that are subject to thread reuse, re-signon, or connection pooling, take one of the following actions to prevent the local or server thread from re-signon, being reused by a different user, or from being pooled:

- Define at least one cursor as WITH HOLD and leave it as OPEN.
- Specify the bind option KEEP DYNAMIC(YES).

Use as a unique key value:

The same sequence number can be used as a unique key value in two separate tables by referencing the sequence number with a NEXT VALUE expression for the first row (this generates the sequence

value), and a PREVIOUS VALUE expression for the other rows (the instance of PREVIOUS VALUE refers to the sequence value most recently generated in the current session), as shown in the following example:

```
INSERT INTO ORDER (ORDERNO, CUSTNO)
  VALUES (NEXT VALUE FOR ORDER_SEQ, 123456);
INSERT INTO LINE_ITEM (ORDERNO, PARTNO, QUANTITY)
  VALUES (PREVIOUS VALUE FOR ORDER_SEQ, 987654, 1);
```

Allowed use of NEXT VALUE and PREVIOUS VALUE:

The NEXT VALUE and PREVIOUS VALUE expressions can be specified in the following places:

- Within the *select-clause* of a SELECT statement or SELECT statement that does not contain a DISTINCT keyword, a GROUP BY clause, an ORDER BY clause, or a set operator.
- Within a VALUES clause of an INSERT statement, including a multiple row INSERT statement with multiple VALUES clauses and the insert operation of a MERGE statement, which can include a NEXT VALUE expression for a particular sequence name for each VALUES clause.
- Within the *select-clause* of the fullselect of an INSERT statement.
- Within the SET clause of a searched or positioned UPDATE statement, including the update operation of the MERGE statement, though NEXT VALUE cannot be specified in the *select-clause* of the fullselect of an expression in the SET clause.

A PREVIOUS VALUE expression can be specified anywhere with a SET clause of an update operation (the UPDATE or MERGE statement), but a NEXT VALUE expression can be specified only in a SET clause if it is not within the *select-clause* of the fullselect of an expression. For instance, the following uses of sequence references are supported:

```
UPDATE T SET C1 = (SELECT PREVIOUS VALUE FOR S1 FROM T);
UPDATE T SET C1 = PREVIOUS VALUE FOR S1;
UPDATE T SET C1 = NEXT VALUE FOR S1;
```

The following uses of sequence references are not supported:

```
UPDATE T SET C1 = (SELECT NEXT VALUE FOR S1 FROM T);
SET :C2 = (SELECT NEXT VALUE FOR S1 FROM T);
```

- In a SET *host-variable* or *assignment-statement*, except within the *select-clause* of the fullselect of an expression.

The following uses of sequence references are supported:

```
SET ORDERNUM = NEXT VALUE FOR INVOICE;
SET ORDERNUM = PREVIOUS VALUE FOR INVOICE;
```

The following uses of sequence references are not supported:

```
SET X = (SELECT NEXT VALUE FOR S1 FROM T);
SET X = (SELECT PREVIOUS VALUE FOR S1 FROM T);
```

- In a VALUES or VALUES INTO statement though not within the *select-clause* of the fullselect of an expression.
- Within the *SQL-routine-body* of a CREATE or ALTER PROCEDURE statement for a SQL procedure.
- Within the *RETURN-statement* of a CREATE FUNCTION statement for an SQL function.
- Within the *SQL-trigger-body* of a CREATE TRIGGER statement (PREVIOUS VALUE is not allowed).

Use of PREVIOUS VALUE in a nested application:

PREVIOUS VALUE is defined to have a linear scope within an application session. Therefore, in a nested application on entry to a nested function, procedure, or trigger, the nested application inherits the most recently generated value for a sequence. That is, an invocation of PREVIOUS VALUE in a nested application reflects sequence activity done in the invoking environment prior to entering the nested application. In addition, on return from a function, procedure, or trigger, the invoking application is affected by any sequence activity in the lower level applications. That is, an invocation

of PREVIOUS VALUE in the invoking application after returning from the nested application reflects any sequence activity that occurred in the lower level applications.

Restrictions on the use of NEXT VALUE and PREVIOUS VALUE:

Some of the places where the NEXT VALUE and PREVIOUS VALUE expressions cannot be specified include the following:

- Join condition of a full outer join
- DEFAULT value for a column in a CREATE TABLE or ALTER TABLE statement
- Materialized query table definition in a CREATE TABLE or ALTER TABLE statement
- Condition of a CHECK constraint
- Input value specification for LOAD
- CREATE VIEW statement
- The SELECT list of a subselect that contains a NOT ATOMIC data change statement
- ORDER BY clause when used in an OLAP specification

In addition, the NEXT VALUE expression cannot be specified in the following places:

- A CASE expression
- The parameter list of an aggregate function
- A subquery in a context other than those explicitly allowed
- A SELECT statement for which the outer SELECT contains a DISTINCT operator or a GROUP BY clause
- A SELECT statement for which the outer SELECT is combined with another SELECT statement using a set operator
- A join condition of a join
- A nested table expression
- The parameter list of a table function
- A *select-clause* of the fullselect of an expression in the SET clause of an UPDATE, a DELETE, or a MERGE statement.
- A WHERE clause of the outer-most SELECT statement or a DELETE, an UPDATE, or a MERGE statement
- An ORDER BY clause of the outer-most SELECT statement
- The select list of a fullselect that contains an OFFSET clause
- An IF, WHILE, DO UNTIL, or CASE statement in an SQL routine

Using sequence expressions with a cursor:

Normally, a SELECT NEXT VALUE FOR ORDER_SEQ FROM T1 would produce a result table containing as many generated values from the sequence ORDER_SEQ as the number of rows retrieved from T1. A reference to a NEXT VALUE expression in the SELECT statement of a cursor refers to a value that is generated for a row of the result table. A sequence value is generated for a NEXT VALUE expression each time a row is retrieved.

If blocking is done at a client in a DRDA environment, sequence values might get generated at the Db2 server before the processing of an application's FETCH statement. If the client application does not explicitly fetch all the rows that have been retrieved from the database, the application will never see all those values of the sequence that are generated but not fetched (as many values as the rows that are not fetched). These generated but not fetched values might constitute a gap in the sequence. If it is important to prevent such a gap in the sequence, do the following:

- Use NEXT VALUE only where it would function without being controlled by a cursor and where block-fetching by the client will have no effect on it.
- If you must use NEXT VALUE in the SELECT statement of a cursor-definition, weigh the importance of preventing the gap against performance and other implications of taking the following actions:

- Use FETCH FOR 1 ROW ONLY clause with the SELECT statement.
- Try preventing block-fetch by other means documented in [Block fetch \(Introduction to Db2 for z/OS\)](#).

Using the PREVIOUS VALUE expression with a cursor:

A reference to the PREVIOUS VALUE expression in a SELECT statement of a cursor is evaluated at OPEN time. In other words, a reference to the PREVIOUS VALUE expression in the SELECT statement of a cursor refers to the last value generated by this application process for the specified sequence prior to the opening of the cursor and, once evaluated at OPEN time, the value returned by PREVIOUS VALUE within the select statement of the cursor will not change from FETCH to FETCH, even if NEXT VALUE is invoked with the select statement of the cursor. After the cursor is closed, the value of PREVIOUS VALUE will be the last NEXT VALUE that is generated by the application process.

IF PREVIOUS VALUE is used in the SELECT statement of a cursor while the cursor is open, the value of PREVIOUS VALUE would be the last NEXT VALUE that was generated for the sequence before the cursor was opened. After the cursor is closed, the value of PREVIOUS VALUE would be the last NEXT VALUE generated by the application process.

Syntax alternatives and synonyms:

For compatibility, the keywords NEXTVAL and PREVVAL can be used as synonyms for NEXT VALUE and PREVIOUS VALUE respectively.

sequence-name .NEXTVAL can be specified in place of NEXT VALUE FOR *sequence-name*, and *sequence-name* .CURRVAL can be specified in place of PREVIOUS VALUE FOR *sequence-name*.

Example

Assume that there is a table called ORDER, and that a sequence called ORDER_SEQ is created as follows:

```
CREATE SEQUENCE ORDER_SEQ START WITH 1
      INCREMENT BY 1
      NO MAXVALUE
      NO CYCLE
      CACHE 24
```

The following examples illustrate how to generate an ORDER_SEQ sequence number with a NEXT VALUE expression:

```
INSERT INTO ORDER (ORDERNO, CUSTNO)
      VALUES (NEXT VALUE FOR ORDER_SEQ, 123456);
UPDATE ORDER SET ORDERNO = NEXT VALUE FOR ORDER_SEQ
      WHERE CUSTNO = 123456;
VALUES NEXT VALUE FOR ORDER_SEQ INTO :HV_SEQ;
```

Predicates

A *predicate* specifies a condition that is true, false, or unknown about a given value, row, or group.

The following rules apply to predicates of any type:

- Predicates are evaluated after the expressions that are operands of the predicate.
- All values that are specified in the same predicate must be compatible.
- Except for the EXISTS predicate, a subquery in a predicate must specify a single column unless the operand on the other side of the comparison operator is a fullselect.
- The value of a host variable can be null (that is, the variable can have a negative indicator variable).
- The CCSID conversion of operands of predicates that involve two or more operands is done according to [“Conversion rules for comparisons” on page 159](#).
- Use of an XML value is limited to the NULL or XMLEXISTS predicates.

The types of predicates are:

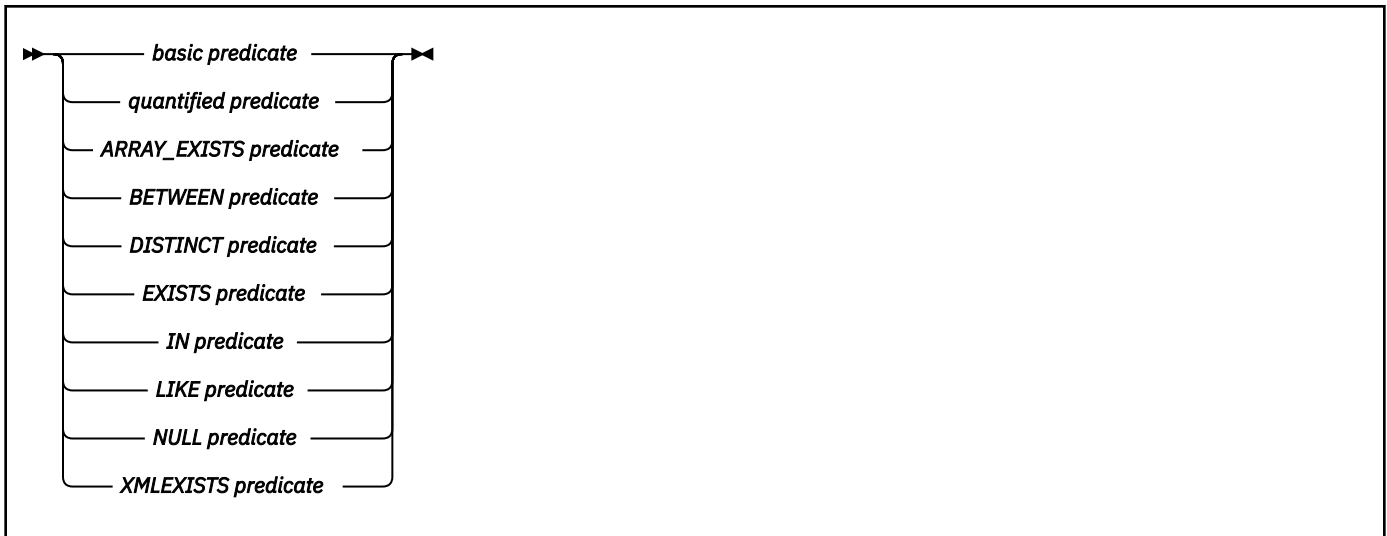

Row-value expression: The operand of several predicates (basic, quantified, DISTINCT, and IN) can be a *row-value-expression*:

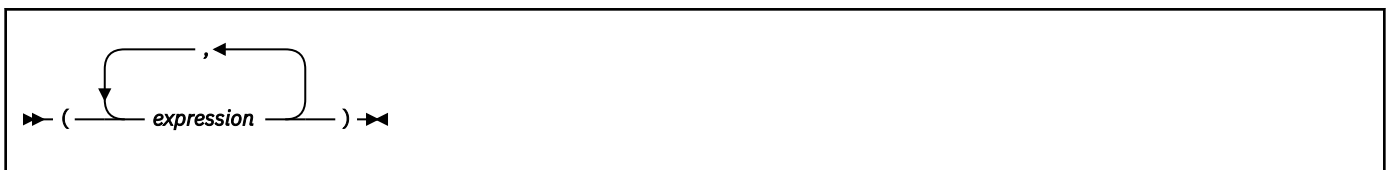

A *row-value-expression* returns a single row that consists of one or more column values. The values can be specified as a list of expressions. The number of columns that are returned by the *row-value-expression* is equal to the number of expressions that are specified in the list.

For several examples of predicates that use distinct types, see [“Assignment and comparison” on page 143](#). For examples of predicates that use distinct types, see [“User-defined type comparisons” on page 164](#).

Related concepts

[Predicates and access path selection \(Db2 Performance\)](#)

Related tasks

[Using predicates efficiently \(Db2 Performance\)](#)

[Writing efficient SQL queries \(Db2 Performance\)](#)

Related reference

[where-clause](#)

The WHERE clause specifies a result table that consists of those rows of R for which the search condition is true. R is the result of the FROM clause of the subselect.

[having-clause](#)

The HAVING clause specifies a result table that consists of those groups of the intermediate result table for which the search-condition is true. The intermediate result table is the result of the previous clause. If this clause is not GROUP BY, the intermediate result table is considered a single group with no grouping columns of the previous clause of the subselect.

Basic predicate

A *basic predicate* compares two values or compares a set of values with another set of values.

¹⁵ The following forms of the comparison operators are also supported in basic and quantified predicates in code pages where the exclamation point is X'5A': !=, !<, and !>. In addition, the forms ¬=, ¬<, and ¬> are supported as long as the code point used for the logical not symbol is the correct one for the specified code

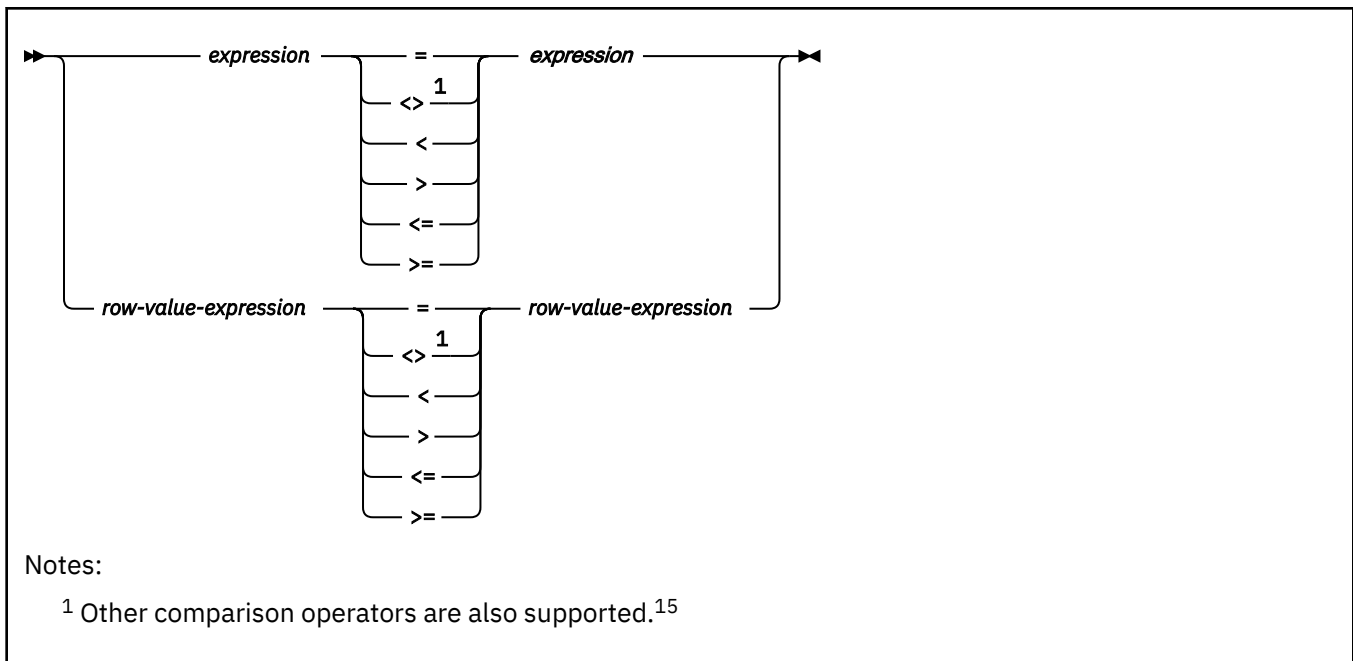

When *expression* is a fullselect, the fullselect must return a single result column with a single value, whether null or not null. If the value of either operand is null or the result of the fullselect is empty, the result of the predicate is unknown. Otherwise, the result is either true or false.

When a *row-value-expression* is specified on the left side of the operator, another *row-value-expression*, with an identical number of value expressions, must be specified on the right side. The data types of the corresponding expressions or columns of the *row-value-expressions* must be compatible.

If the comparison operator is *<*, *<=*, *>*, or *>=*, *row-value-expression* must not reference a non-deterministic expression, a function with external action, or a scalar fullselect.

The value of each expression on the left side is compared with the value of its corresponding expression on the right side. The result of the predicate depends on the operator, as in the following:

- If the operator is *=*, the result of the predicate is:
 - True - if all pairs of corresponding value expressions evaluate to true.
 - False - if any one pair of corresponding value expressions evaluates to false.
 - Unknown - if the comparisons is neither true nor false. That is, if at least one comparison of corresponding value expressions is unknown because of a null value and no pair of corresponding value expressions evaluates to false.
- If the operator is *<>*, the result of the predicate $(Rx1, Rx2, \dots, Rxn) <> (Ry1, Ry2, \dots, Ryn)$ is:
 - True - if, and only if, $Rxi=Ryi$ evaluates to false for some value of *i*. That is, there is at least one pair of non-null values, Rxi and Ryi , that are not equal to each other.
 - False - if, and only if, $Rxi=Ryi$ evaluates to true for every value of *i*. That is, $Rx1, Rx2, \dots, Rxn)=(Ry1, Ry2, \dots, Ryn)$ is true.
 - Unknown - if the comparison is neither true nor false. That is, Rxi or Ryi is a null value for some value of *i*, and there is no value of *j* such that $Rxj=Ryj$ evaluates to false.
- If the operator is *<*, the result of the predicate is:

page. These forms of the operators are intended only to support existing SQL statements that use them and are not recommended for use when writing new SQL statements.

A logical not sign (*¬*) can cause parsing errors in statements passed from one DBMS to another. The problem occurs if the statement undergoes character conversion with certain combinations of source and target CCSIDs. To avoid this problem, substitute an equivalent operator for any operator that includes a not sign. For example, substitute *<>* for *¬=*, *<=* for *¬>*, and *>=* for *¬<*.

- True - if, and only if, the first N pairs of the corresponding value expressions are equal and the next pair has the left value expression less than the right value expression for some value of N . That is, $Rxi = Ryi$ is true for all values of $i < n$ and $Rxn < Ryn$ is true for some value of n .
- False - if, and only if, all pairs of the corresponding value expressions are equal ($Rx = Ry$ is true) or the first N pairs of the corresponding value expressions are equal and the next pair has the right value expression less than the left value expression for some value of N . That is, $Rxi = Ryi$ is true for all values of $i < n$ and $Rxn > Ryn$ is true for some value of n .
- Unknown - if the comparison is neither true nor false.
- If the operator is $<=$, the result of the predicate is:
 - True - if, and only if, the first N pairs of the corresponding value expressions are equal and the next pair has the left value expression less than or equal to the right value expression for some value of N . That is, $Rxi = Ryi$ is true for all values of $i < n$ and $Rxn <= Ryn$ is true for some value of n .
 - False - if, and only if, all pairs of the corresponding value expressions are equal ($Rx = Ry$ is true) or the first N pairs of the corresponding value expressions are equal and the next pair has the right value expression less than the left value expression for some value of N . That is, $Rxi = Ryi$ is true for all values of $i < n$ and $Rxn > Ryn$ is true for some value of n .
 - Unknown - if the comparison is neither true nor false.
- If the operator is $>$, the result of the predicate is:
 - True - if, and only if, the first N pairs of the corresponding value expressions are equal and the next pair has the left value expression greater than the right value expression for some value of N . That is, $Rxi = Ryi$ is true for all values of $i < n$ and $Rxn > Ryn$ is true for some value of n .
 - False - if, and only if, all pairs of the corresponding value expressions are equal ($Rx = Ry$ is true) or the first N pairs of the corresponding value expressions are equal and the next pair has the right value expression greater than the left value expression for some value of N . That is, $Rxi = Ryi$ is true for all values of $i < n$ and $Rxn <= Ryn$ is true for some value of n .
 - Unknown - if the comparison is neither true nor false.
- If the operator is $>=$, the result of the predicate is:
 - True - if, and only if, the first N pairs of the corresponding value expressions are equal and the next pair has the left value expression greater than or equal to the right value expression for some value of N . That is, $Rxi = Ryi$ is true for all values of $i < n$ and $Rxn >= Ryn$ is true for some value of n .
 - False - if, and only if, all pairs of the corresponding value expressions are equal ($Rx = Ry$ is true) or the first N pairs of the corresponding value expressions are equal and the next pair has the right value expression greater than the left value expression for some value of N . That is, $Rxi = Ryi$ is true for all values of $i < n$ and $Rxn < Ryn$ is true for some value of n .
 - Unknown - if the comparison is neither true nor false.

<i>Table 54. For values x and y</i>	
Predicate	Is true if and only if ...
$x = y$	x is equal to y
$x <> y$	x is not equal to y
$x < y$	x is less than y
$x > y$	x is greater than y
$x <= y$	x is less than or equal to y
$x >= y$	x is greater than or equal to y

Examples for values x and y :

```
EMPNO = '528671'
SALARY < 20000
```

```
PRSTAFF <> :VAR1
SALARY >= (SELECT AVG(SALARY) FROM DSN8C10.EMP)
```

Example: List the name, first name, and salary of the employee who is responsible for the 'SECRET' project. This employee might appear in either the PROJA1 or PROJA2 tables. A UNION is used in case the employee appears in both tables to eliminate duplicate RESPEMP values.

```
SELECT LASTNAME, FIRSTNAME, SALARY
FROM DSN8C10.EMP X
WHERE EMPNO = (
SELECT RESPEMP
FROM PROJA1 Y
WHERE MAJPROJ = 'SECRET'
UNION
SELECT RESPEMP
FROM PROJA2 Z
WHERE MAJPROJ = 'SECRET');
```

Quantified predicate

A *quantified predicate* compares a value or values with a collection of values.

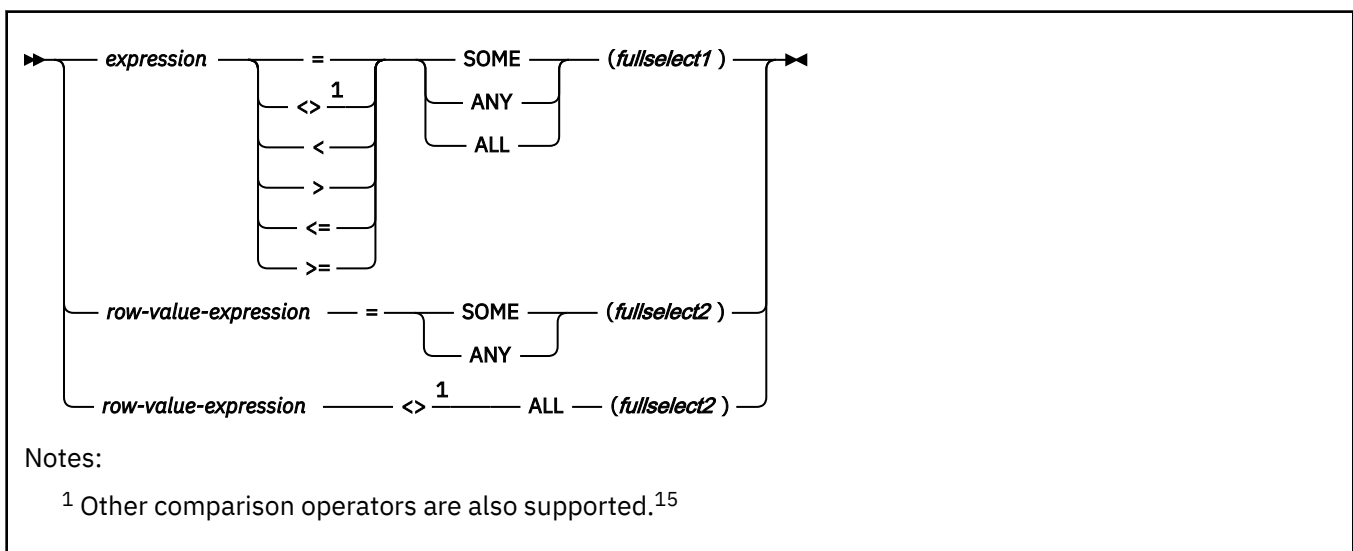

When *expression* is specified, *fullselect1* must return a single result column, and can return any number of values, whether null or not null. The result depends on the operator that is specified:

- When the operator is ALL, the result of the predicate is:
 - True – if the result of the fullselect is empty or if the specified relationship is true for every value returned by the fullselect.
 - False – if the specified relationship is false for at least one value returned by the fullselect.
 - Unknown – if the specified relationship is not false for any values returned by the fullselect and at least one comparison is unknown because of a null value.
- When the operator is SOME or ANY, the result of the predicate is:
 - True – if the specified relationship is true for at least one value returned by the fullselect.
 - False – if the result of the fullselect is empty or if the specified relationship is false for every value returned by the fullselect.
 - Unknown – if the specified relationship is not true for any of the values returned by the fullselect and at least one comparison is unknown because of a null value.

When *row-value-expression* is specified, the number of result columns returned by *fullselect2* must be the same as the number of value expressions specified by *row-value-expression*, and *fullselect2* can return any number of rows of values. The data types of the corresponding expressions of the row value expressions must be compatible. The value of each expression from *row-value-expression* is compared

with the value of the corresponding result column from *fullselect2*. The value of the predicate depends on the operator that is specified:

- When the operator is ALL, the result of the predicate is:
 - True – if the result of *fullselect2* is empty or if the specified relationship is true for every row returned by *fullselect2*.
 - False – if the specified relationship is false for at least one row returned by *fullselect2*.
 - Unknown – if the specified relationship is not false for any row returned by *fullselect2* and at least one comparison is unknown because of a null value.
- When the operator is SOME or ANY, the result of the predicate is:
 - True – if the specified relationship is true for at least one row returned by *fullselect2*
 - False – if the result of the fullselect is empty or if the specified relationship is false for every row returned by *fullselect2*.
 - Unknown – if the specified relationship is not true for any of the rows returned by *fullselect2* and at least one comparison is unknown because of a null value.

Quantified predicates are equivalent to IN predicates. See [Table 60 on page 307](#) for some examples of equivalent quantified and IN predicates.

Examples: Use the following tables when referring to the following examples. In all examples, "row *n* of TBLA" refers to the row in TBLA for which COLA has the value *n*.

<i>Table 55. TBLA</i>	
COLA	
1	
2	
3	
4	

<i>Table 56. TBLB</i>	
COLB	COLC
2	2
3	--

<i>Table 57. TBLC</i>	
COLB	COLC
2	2

Example 1: In the following predicate, the fullselect returns the values 2 and 3. The predicate is false for rows 1, 2, and 3 of TBLA, and is true for row 4.

```
COLA > ALL(SELECT COLB FROM TBLB
           UNION
           SELECT COLB FROM TBLC)
```

Example 2: In the following predicate, the fullselect returns the values 2 and 3. The predicate is false for rows 1 and 2 of TBLA, and is true for rows 3 and 4.

```
COLA > ANY(SELECT COLB FROM TBLB
           UNION
           SELECT COLB FROM TBLC)
```

Example 3: In the following predicate, the fullselect returns the values 2 and null. The predicate is false for rows 1 and 2 of TBLA, and is unknown for rows 3 and 4. The result is an empty table.

```
COLA > ALL(SELECT COLC FROM TBLB
           UNION
           SELECT COLC FROM TBLC)
```

Example 4: In the following predicate, the fullselect returns the values 2 and null. The predicate is unknown for rows 1 and 2 of TBLA, and is true for rows 3 and 4.

```
COLA > SOME(SELECT COLC FROM TBLB
            UNION
            SELECT COLC FROM TBLC)
```

Example 5: In the following predicate, the fullselect returns an empty result column. Hence, the predicate is true for all rows of TBLA.

```
COLA < ALL(SELECT COLB FROM TBLB WHERE COLB>3
           UNION
           SELECT COLB FROM TBLC WHERE COLB>3)
```

Example 6: In the following predicate, the fullselect returns an empty result column. Hence, the predicate is false for all rows of TBLA.

```
COLA < ANY(SELECT COLB FROM TBLB WHERE COLB>3
           UNION
           SELECT COLB FROM TBLC WHERE COLB>3)
```

If COLA were null in one or more rows of TBLA, the predicate would still be false for all rows of TBLA.

ARRAY_EXISTS predicate

The ARRAY_EXISTS predicate tests for the existence of an array element with the specified index in an array.

```
►► ARRAY_EXISTS (array-expression ,array-index ) ◄◄
```

array-expression

Specifies one of the following items:

- An SQL variable, SQL parameter, or global variable of an array type
- A CAST specification of an array or parameter marker to an array type.

array-index

Specifies the index for the array element that is to be tested. An array index value for an ordinary array must be castable to INTEGER. An array index value for an associative array must be castable to the data type of the array index.

array-index must *not* be an expression that references any of the following items:

- The CURRENT DATE, CURRENT TIME, or CURRENT TIMESTAMP special register
- A nondeterministic function
- A function that is defined with EXTERNAL ACTION
- A function that is defined with MODIFIES SQL DATA
- A sequence expression

The result of the ARRAY_EXISTS predicate is:

- True if *array-expression* includes an array index that is equal to the result of casting *array-index* to the data type of the array index of *array-expression*.
- False under either of the following conditions:

- *array-expression* does not include an array index that is equal to the result of casting *array-index* to the data type of the array index of *array-expression*.
- Either argument is null.
- Cannot be unknown.

Example: Suppose that array variable RECENT_CALLS is defined as an ordinary array of array type PHONENUMBERS. The following IF statement tests whether the recent calls list has reached the 40th saved call. If it has, the local integer variable EIGHTY_PERCENT is set to 1:

```
IF (ARRAY_EXISTS(RECENT_CALLS, 40))
  THEN SET EIGHTY_PERCENT = 1;
END IF
```

Related concepts

Array types and values

A user-defined *array type* is a data type that is defined as an array of elements. A user-defined array type can be either an *ordinary array* or *associative array*.

BETWEEN predicate

The BETWEEN predicate determines whether a given value lies between two other given values that are specified in ascending order.

► *expression* — **BETWEEN** — *expression* — **AND** — *expression* ►
 NOT

Each of the predicate's two forms has an equivalent search condition, as shown in the following table:

Table 58. BETWEEN predicate and equivalent search conditions

BETWEEN predicate	Equivalent search condition
<i>value1</i> BETWEEN <i>value2</i> AND <i>value3</i>	<i>value1</i> >= <i>value2</i> AND <i>value1</i> <= <i>value3</i> ¹
<i>value1</i> NOT BETWEEN <i>value2</i> AND <i>value3</i>	<i>value1</i> < <i>value2</i> OR <i>value1</i> > <i>value3</i> ¹

or, equivalently:

NOT(*value1* BETWEEN *value2* AND *value3*)

Note: 1. Might not be equivalent if *value1*, *value2*, or *value3* are columns or derived values based on columns that are not the same CCSID set because the clause is evaluated in Unicode.

Search conditions are discussed in “Search conditions” on page 319.

If the operands include a mixture of datetime values and valid string representations of datetime values, all values are converted to the data type of the datetime operand.

Example: Consider the following predicate:

```
A BETWEEN B AND C
```

The following table shows the value of the predicate for various values of A, B, and C.

Value of A	Value of B	Value of C	Value of predicate
1,2, or 3	1	3	true
0 or 4	1	3	false

Value of A	Value of B	Value of C	Value of predicate
0	1	null	false
4	null	3	false
null	any value	any value	unknown
2	1	null	unknown
3	null	4	unknown

DISTINCT predicate

A distinct predicate compares a value with another value or a set of values with another set of values.

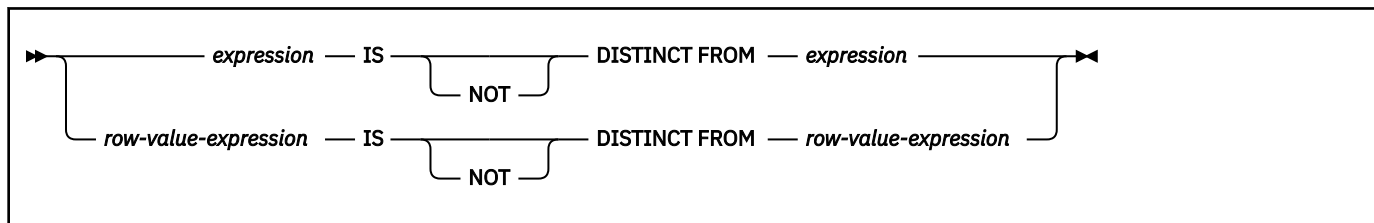

expression and *row-value-expression* cannot be array expressions.

The number of elements that are returned by the *row-value-expression* that specified after the distinct operator must match the number of elements that are returned by the *row-value-expression* that is specified prior to the distinct operator. The data types of the corresponding columns or expressions of the *row-value-expressions* must be compatible. When the predicate is evaluated, the value of each expression on the left side is compared with the value of its corresponding expression on the right side. The result of the predicate depends on the form of the predicate.

When the predicate is `IS DISTINCT`, the result of the predicate is true if at least one comparison of a pair of corresponding value expressions evaluates to false. Otherwise, the result of the predicate is false. The result cannot be unknown.

When the predicate is `IS NOT DISTINCT FROM`, the result of the predicate is true if all pairs of corresponding value expressions evaluate to true (null values are considered equal to null values). Otherwise, the predicate is false. The result cannot be unknown.

The DISTINCT predicate cannot be used in the following contexts:

- The `ON join-condition` of a full outer join
- A check constraint
- A quantified predicate

The following DISTINCT predicates are logically equivalent to the corresponding search conditions:

DISTINCT predicate	Search condition
<code>value 1 IS NOT DISTINCT FROM value2</code>	<code>(value1 IS NOT NULL AND value2 IS NOT NULL AND value1 = value 2) OR (value1 IS NULL AND value2 IS NULL)</code>
<code>value 1 IS DISTINCT FROM value2</code>	<code>NOT (value1 IS NOT DISTINCT FROM value2)</code>

Example 1: Assume that T1 is a single-column table with three rows. Column C1 has the following values: 1, 2, and null. Consider the following query:

```
SELECT * FROM T1
WHERE C1 IS DISTINCT FROM :HV;
```

The following table shows the value of the predicate for various values of C1 and the host variable.

Value of C1	Value of HV	Result of predicate
1	2	True
2	2	False
null	2	True
1	null	True
2	null	True
null	null	False

Example 2: Assume the same table as in the first example, but now consider the negative form of the predicate in the query:

```
SELECT * FROM T1
WHERE C1 IS NOT DISTINCT FROM :HV;
```

The following table shows the value of the predicate for various values of C1 and the host variable.

Value of C1	Value of HV	Result of predicate
1	2	False
2	2	True
null	2	False
1	null	False
2	null	False
null	null	True

EXISTS predicate

The EXISTS predicate tests for the existence of certain rows. The fullselect can specify any number of columns, and can result in true or false.

►► EXISTS (*fullselect*¹) ◄◄

Notes:

¹ The outer SELECT list of *fullselect* must not contain an array value.

The result of the EXISTS predicate:

- Is true only if the number of rows that is specified by the fullselect is not zero.
- Is false only if the number of rows specified by the fullselect is zero.
- Cannot be unknown.

The SELECT clause in the fullselect can specify any number of columns because the values returned by the fullselect are ignored. For convenience, use:

```
SELECT *
```

Unlike the NULL, LIKE, and IN predicates, the EXISTS predicate has no form that contains the word NOT. To negate an EXISTS predicate, precede it with the logical operator NOT, as follows:

```
NOT EXISTS (fullselect)
```

The result is then false if the EXISTS predicate is true, and true if the predicate is false. Here, NOT is a logical operator and not a part of the predicate. Logical operators are discussed in [“Search conditions” on page 319](#).

Example 1: The following query lists the employee number of everyone represented in DSN8C10.EMP who works in a department where at least one employee has a salary less than 20000. Like many EXISTS predicates, the one in this query involves a correlated variable.

```
SELECT EMPNO
FROM DSN8C10.EMP X
WHERE EXISTS (SELECT * FROM DSN8C10.EMP
             WHERE X.WORKDEPT=WORKDEPT AND SALARY<20000);
```

Example 2: List the subscribers (SNO) in the state of California who made at least one call during the first quarter of 2009. Order the results according to SNO. Each MONTH nn table has columns for SNO, CHARGES, and DATE. The CUST table has columns for SNO and STATE.

```
SELECT C.SNO
FROM CUST C
WHERE C.STATE = 'CA'
AND EXISTS (
  SELECT *
  FROM MONTH1
  WHERE DATE BETWEEN '01/01/2009 AND '01/31/2009'
  AND C.SNO = SNO
  UNION ALL
  SELECT *
  FROM MONTH2
  WHERE DATE BETWEEN '02/01/2009 AND '02/28/2009'
  AND C.SNO = SNO
  UNION ALL
  SELECT *
  FROM MONTH3
  WHERE DATE BETWEEN '03/01/2009 AND '03/31/2009'
  AND C.SNO = SNO
)
ORDER BY C.SNO;
```

IN predicate

The IN predicate compares a value or values with a set of values.

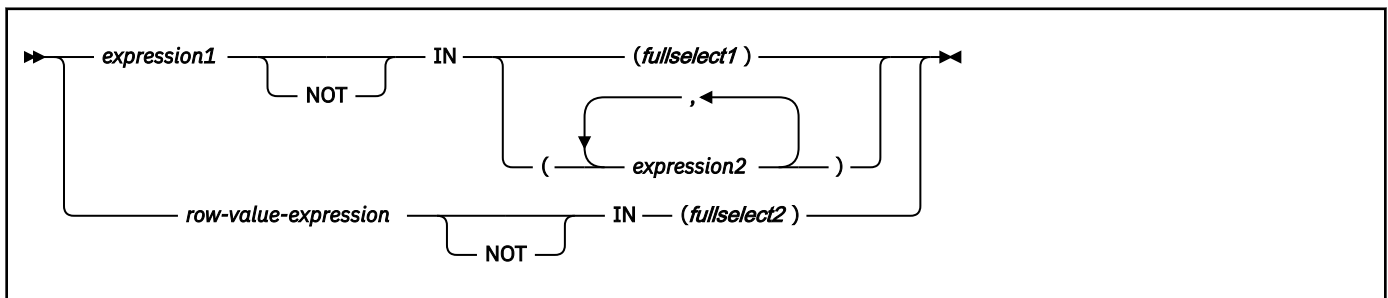

When *expression1* is specified, the IN predicate compares a value with a set of values. When *fullselect1* is specified, the fullselect must return a single result column, and can return any number of values, whether null or not null. The data type of *expression1* and the data type of the result column of *fullselect1* or *expression2* must be compatible. If *expression* is a single host variable, the host variable can identify a structure. Any host variable or structure that is specified must be described in the application program according to the rules for declaring host structures and variables.

When a *row-value-expression* is specified, the IN predicate compares values with a collection of values. The result table of the *fullselect2* must have the same number of columns as the *row-value-expression*. The data type of each expression in *row-value-expression* and the data type of its the corresponding result column of *fullselect2* must be compatible. The value of each expression in *row-value-expression* is compared with the value of its corresponding result column of *fullselect2*. The value of the predicate depends on the operator that is specified:

- When the operator is IN, the result of the predicate is:
 - True if at least one row returned from *fullselect2* is equal to the *row-value-expression*.
 - False if the result of *fullselect2* is empty or if no row returned from *fullselect2* is equal to the *row-value-expression*.
 - Otherwise, unknown (that is, if the comparison of *row-value-expression* to the row returned from *fullselect2* evaluates to unknown because of a null value for at least one row returned from *fullselect2* and no row returned from *fullselect2* is equal to the *row-value-expression*).

- When the operator is NOT IN, the result of the predicate is:

True if the result of *fullselect2* is empty or if the *row-value-expression* is not equal to any of the rows returned by *fullselect2*.

False if the *row-value-expression* is equal to at least one row returned by *fullselect2*.

Otherwise, unknown (that is, if the comparison of *row-value-expression* to the row returned from *fullselect2* evaluates to unknown because of a null value for at least one row returned from *fullselect2* and the comparison of *row-value-expression* to the row returned from *fullselect2* is not true for any row returned by the *fullselect2*).

The IN predicate is equivalent to the quantified predicate as follows:

Table 60. IN predicate and equivalent quantified predicates

IN predicate	Equivalent quantified predicate
<i>expression1</i> IN (<i>expression2</i>)	<i>expression1</i> = <i>expression2</i>
<i>expression</i> IN (<i>fullselect1</i>)	<i>expression</i> = ANY (<i>fullselect1</i>)
<i>expression</i> NOT IN (<i>fullselect1</i>)	<i>expression</i> <> ALL (<i>fullselect1</i>)
<i>expression1</i> IN (<i>expressiona</i> , <i>expressionb</i> , ...)	<i>expression1</i> IN (SELECT * FROM R) When T is a table with a single row and R is a result table formed by the following fullselect: <pre>SELECT value1 FROM T UNION SELECT value2 FROM T UNION . . UNION SELECT valuen FROM T</pre>
<i>row-value-expression</i> IN (<i>fullselect2</i>)	<i>row-value-expression</i> = SOME (<i>fullselect2</i>)
<i>row-value-expression</i> IN (<i>fullselect2</i>)	<i>row-value-expression</i> = ANY (<i>fullselect2</i>)
<i>row-value-expression</i> NOT IN (<i>fullselect2</i>)	<i>row-value-expression</i> <> ALL (<i>fullselect2</i>)

If the operands of the IN predicate have different data types or attributes, the rules that are used to determine the data type for evaluation of the IN predicate are those for UNION, EXCEPT, and INTERSECT. For a description, see “Rules for result data types” on page 166.

If the operands of the IN predicate are strings with different CCSIDs, the rules used to determine which operands are converted are those for operations that combine strings. See [#unique_393](#).

Examples

Example 1

The following predicate is true for any row whose employee is in department D11, B01, or C01.

```
WORKDEPT IN ('D11', 'B01', 'C01')
```

Example 2

The following predicate is true for any row whose employee works in department E11.

```
EMPNO IN (SELECT EMPNO FROM DSN8C10.EMP
WHERE WORKDEPT = 'E11')
```

Example 3

The following predicate is true if the date that a project is estimated to start (PRENDATE) is within the next two years.

```
YEAR(PRENDATE) IN (YEAR(CURRENT DATE),
YEAR(CURRENT DATE + 1 YEAR),
YEAR(CURRENT DATE + 2 YEARS))
```

Example 4

The following example obtains the phone number of an employee in DSN8C10.EMP where the employee number (EMPNO) is a value specified within the COBOL structure defined below.

```
77 PHNUM PIC X(6).
01 EMPNO-STRUCTURE.
05 CHAR-ELEMENT-1 PIC X(6) VALUE '000140'.
05 CHAR-ELEMENT-2 PIC X(6) VALUE '000340'.
05 CHAR-ELEMENT-3 PIC X(6) VALUE '000220'.
.
.
EXEC SQL DECLARE PHCURS CURSOR FOR
SELECT PHONENO FROM DSN8C10.EMP
WHERE EMPNO IN
(:EMPNO-STRUCTURE.CHAR-ELEMENT-1,
:EMPNO-STRUCTURE.CHAR-ELEMENT-2,
:EMPNO-STRUCTURE.CHAR-ELEMENT-3)
END-EXEC.
EXEC SQL OPEN PHCURS
END-EXEC.
EXEC SQL FETCH PHCURS INTO :PHNUM
END-EXEC.
```

LIKE predicate

The LIKE predicate searches for strings that have a certain pattern.

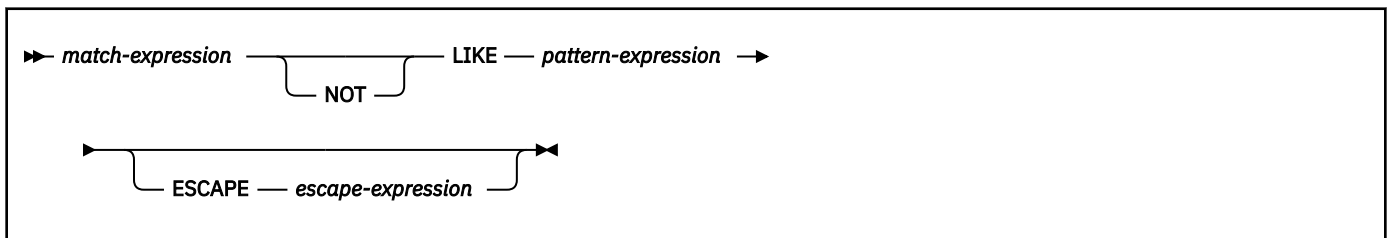

The *match-expression* is the string to be tested for conformity to the pattern specified in *pattern-expression*. Underscore and percent sign characters in the pattern have a special meaning instead of

their literal meanings unless *escape-expression* is specified. For more information, see the description of *pattern-expression*.

The following rules summarize how a predicate in the form of *m* LIKE *p* is evaluated:

- If *m* or *p* is null, the result of the predicate is unknown.
- If *m* and *p* are both empty, the result of the predicate is true.
- If *m* is empty and *p* is not, the result of the predicate is unknown unless *p* consists of one or more percent signs.
- If *m* is not empty and *p* is empty, the result of the predicate is false.
- Otherwise, if *m* matches the pattern in *p*, the result of the predicate is true. The description of *pattern-expression* provides a detailed explanation on how the pattern is matched to evaluate the predicate to true or false.

The way the pattern is matched to evaluate the predicate changes when *LIKE blank insignificant* behavior is enabled. For more information, see [“LIKE blank insignificant behavior subsystem parameter” on page 314](#).

The values for *match-expression*, *pattern-expression*, and *escape-expression* must all be character or graphic strings or a mixture of both or they must all be binary strings (BLOBs). None of the expressions can yield a distinct type; however, an expression can be a function that casts a distinct type to its source type.

There are slight differences in what expressions are supported for each argument. The description of each argument lists the supported expressions.

match-expression

An expression that specifies the string to be tested for conformity to a certain pattern of characters.

LIKE *pattern-expression*

An expression that specifies the pattern of characters to be matched.

The expression can be specified by any one of the following:

- A constant
- A special register
- A variable
- A scalar function whose arguments are any of the above (though nested function invocations cannot be used)
- An array element specification
- A CAST specification whose arguments are any of the above
- An expression that concatenates (using CONCAT or ||) any of the above

The expression must also meet these restrictions:

- The maximum length of *pattern-expression* must not be larger than 4000 bytes.
- If a host variable is used in *pattern-expression*, the host variable must be defined in accordance with the rules for declaring string host variables and must not be a structure. For more information about the use of host variables with specific programming languages, see [Host variables \(Db2 Application programming and SQL\)](#).
- If *escape-expression* is specified, *pattern-expression* must not contain the escape character that is identified by *escape-expression*, except when immediately followed by the escape character, '%', or '_'. For example, if '+' is the escape character, any occurrences of '+' other than '++', '+_', or '+%' in the pattern is an error.

The pattern is used to specify the conformance criteria for values in the *match-expression* where:

- The underscore character (_) represents any single character.
- The percent sign (%) represents a string of zero or more characters.
- Any other character represents a single occurrence of itself.

If the *pattern-expression* must include either the underscore or the percent character, the *escape-expression* is used to specify a character to precede either the underscore or percent character in the pattern. For character strings, the terms *character*, *percent sign*, and *underscore* refer to SBCS characters. For graphic strings, the terms refer to double-byte or UTF-16 characters.

If the pattern is specified in a fixed-length string variable, any trailing blanks are interpreted as part of the pattern. Therefore, it is better to use a varying-length string variable with an actual length that is the same as the length of the pattern. If the host language does not allow varying-length string variables, place the pattern in a fixed-length string variable whose length is the length of the pattern.

A rigorous description of the pattern: This more rigorous description of the pattern ignores the use of the *escape-expression*.

Let *m* denote the value of *match-expression* and let *p* denote the value of *pattern-expression*. The string *p* is interpreted as a sequence of the minimum number of substring specifiers so each character of *p* is part of exactly one substring specifier. A substring specifier is an underscore, a percent sign, or any non-empty sequence of characters other than an underscore or a percent sign.

The result of the predicate is unknown if *m* or *p* is the null value. Otherwise, the result is either true or false. The result is true if *m* and *p* are both empty strings or there exists a partitioning of *m* into substrings such that:

- A substring of *m* is a sequence of zero or more contiguous characters and each character of *m* is part of exactly one substring.
- If the *n*th substring specifier is an underscore, the *n*th substring of *m* is any single character.
- If the *n*th substring specifier is a percent sign, the *n*th substring of *m* is any sequence of zero or more characters.
- If the *n*th substring specifier is neither an underscore nor a percent sign, the *n*th substring of *m* is equal to that substring specifier and has the same length as that substring specifier.
- The number of substrings of *m* is the same as the number of substring specifiers.

It follows that if *p* is an empty string and *m* is not an empty string, the result is false. Similarly, if *m* is an empty string and *p* is not an empty string consisting of a value other than percentage signs, the result is false.

The predicate *m* NOT LIKE *p* is equivalent to the search condition NOT (*m* LIKE *p*).

Mixed data patterns: If *match-expression* represents mixed data, the pattern is assumed to be mixed data. For ASCII and EBCDIC, the special characters in the pattern are interpreted as follows:

- An SBCS underscore refers to one SBCS character.
- A DBCS underscore refers to one MBCS character.
- A percent sign (either SBCS or DBCS) refers to a string of zero or more SBCS or MBCS characters.

For EBCDIC, redundant shift bytes in *match-expression* or *pattern-expression* are ignored.

For Unicode, the special characters in the pattern are interpreted as follows:

- An SBCS or DBCS underscore refers to one character (either SBCS or MBCS).
- A percent sign (either SBCS or DBCS) refers to a string of zero or more SBCS or MBCS characters.

When the LIKE predicate is used with Unicode data, the Unicode percent sign and underscore use the code points indicated in the following table:

Character	UTF-8	UTF-16
Half-width %	X'25'	X'0025'
Full-width %	X'EFBC85'	X'FF05'
Half-width_	X'5F'	X'005F'

Character	UTF-8	UTF-16
Full-width_	X'EFBCBF'	X'FF3F'

The full-width or half-width % matches zero or more characters. The full-width or half-width_ character matches exactly one character. (For ASCII or EBCDIC data, a full-width _ character matches one DBCS character.)

Binary data patterns: For columns with binary data, the pattern contains bytes. The special bytes in the pattern are interpreted as follows:

- The code point for an SBCS underscore (X'6D') refers to 1 byte.
- The code point for an SBCS percent (X'6C') refers to any number of bytes.

Parameter marker:

When the pattern specified in a LIKE predicate is a parameter marker and a fixed-length character variable is used to replace the parameter marker, specify a value for the variable that is the correct length. If you do not specify the correct length, the select does not return the intended results.

For example, if the variable is defined as CHAR(10) and the value 'WYSE%' is assigned to that variable, the variable is padded with blanks on assignment. The pattern used is 'WYSE% ', which requests Db2 to search for all values that start with 'WYSE' and end with five blank spaces unless *LIKE blank insignificant* behavior is in effect. If the search was intended to search only for the values that start with 'WYSE', then assign the value 'WYSE%%%%%%%%' to the variable.

ESCAPE escape-expression

An expression that specifies the escape character to be used to modify the special meaning of the underscore (_) and percent (%) characters in *pattern-expression*. Specifying an expression, which is optional, allows the LIKE predicate to explicitly test that the value contains a '%' or '_' in the character positions that you want. The escape character consists of a single SBCS (1 byte) or DBCS (2 bytes) character. An escape clause is allowed for Unicode mixed (UTF-8) data, but is restricted for ASCII and EBCDIC mixed data.

The expression can be specified by:

- A constant
- A variable
- A scalar function whose arguments are any of the above (though nested function invocations cannot be used)
- A CAST specification whose arguments are any of the above

The following rules also apply to the use of the ESCAPE clause and *escape-expression*:

- The result of *escape-expression* must be one SBCS or DBCS character or a binary string that contains exactly 1 byte.
- The ESCAPE clause cannot be used if *match-expression* is mixed data.
- If *escape-expression* is specified by a host variable, the host variable must be defined in accordance with the rules for declaring fixed-length string host variables.

Note: If it is NUL-terminated, a C character string variable of length 2 can be specified.

If the host variable has a negative indicator variable, the result of the predicate is unknown.

- The pattern must not contain the escape character except when followed by the escape character, '%' or '_'. For example, if '+' is the escape character, any occurrences of '+' other than '++', '+_', or '+%' in the pattern is an error.

The following table shows the effect of successive occurrences of the escape character, which in this case is the plus sign (+).

Table 61. Effect of successive occurrences of the escape character

When the pattern string is...	The actual pattern is...
+%	A percent sign
++%	A plus sign followed by zero or more arbitrary characters
+++%	A plus sign followed by a percent sign

Examples

Example 1

The following predicate is true when the string to be tested in NAME has the value SMITH, NESMITH, SMITHSON, or NESMITHY. It is not true when the string has the value SMYTHE:

```
NAME LIKE '%SMITH%'
```

Example 2

In the predicate below, a host variable named PATTERN holds the string for the pattern:

```
NAME LIKE :PATTERN ESCAPE '+'
```

Assume that the string in PATTERN has the following value:

```
AB+_C_%
```

Observe that in this string, the plus sign preceding the first underscore is an escape character. The predicate is true when the string being tested in NAME has the value AB_CD or AB_CDE. It is false when this string has the value AB, AB_, or AB_C.

Example 3

The following two predicates are equivalent; three of the four percent signs in the first predicate are redundant.

```
NAME LIKE 'AB%%%%CD'  
NAME LIKE 'AB%CD'
```

Example 4

Assume that a distinct type named ZIP_TYPE with a source data type of CHAR(5) exists and an ADDRZIP column with data type ZIP_TYPE exists in some table TABLEY. The following statement selects the row if the zip code (ADDRZIP) begins with '9555'.

```
SELECT * FROM TABLEY  
WHERE CHAR(ADDRZIP) LIKE '9555%'
```

Example 5

The RESUME column in sample table DSN8C10.EMP_PHOTO_RESUME is defined as a CLOB. The following statement selects the RESUME column when the string JONES appears anywhere in the column.

```
SELECT RESUME FROM DSN8C10.EMP_PHOTO_RESUME  
WHERE RESUME LIKE '%JONES%'
```

Example 6

In the following table, assume COL1 is a column that contains mixed EBCDIC data. The table shows the results when the predicate in the first column is evaluated using the COL1 value in the second column:

Predicates	COL1 Values	Result
WHERE COL1 LIKE 'aaa AB%C'	'aaa ABDZC'	True
WHERE COL1 LIKE 'aaa AB% C'	'aaa AB dzx C'	True
WHERE COL1 LIKE 'a% C'	'a C'	True
	'ax C'	True
	'ab DE fg C'	True
	'a% C'	True
	'a XC'	False
WHERE COL1 LIKE 'a% _C'	'a XC'	True
	'ax C'	False
WHERE COL1 LIKE ''	Empty string	True
WHERE COL1 LIKE 'ab C_d'	'ab C d'	True
	'ab C d'	True

Example 7

In the following table, assume COL1 is a column that contains mixed ASCII data. The table shows the results when the predicate in the first column is evaluated using the COL1 value in the second column:

Predicates	COL1 Values	Result
WHERE COL1 LIKE 'aaa AB%C'	'aaaABDZC'	True
WHERE COL1 LIKE 'aaa AB%C'	'aaaABdzxC'	True

Example 8

In the following table, assume COL1 is a column that contains Unicode data. The table shows the results when the predicate in the first column is evaluated using the COL1 value in the second column:

Table 62. COL1 contain Unicode data

Predicates	COL1 values	Result
WHERE COL1 LIKE 'aaaAB%C'	'aaaABDZC'	True
	'aaaABdzxC'	True
	empty string	False
WHERE COL1 LIKE 'aaaAB %C'	'aaaABDZC'	True
	'aaaABdzxC'	True
	empty string	False
WHERE COL1 LIKE ''	'aaaABDZC'	False
	'aaaABdzxC'	False
	empty string	True
WHERE COL1 LIKE '%'	'aaaABDZC'	True
	'aaaABdzxC'	True
	empty string	True
WHERE COL1 LIKE ' %'	'aaaABDZC'	True
	'aaaABdzxC'	True
	empty string	False

Table 62. COL1 contain Unicode data (continued)

Predicates	COL1 values	Result
WHERE COL1 LIKE ' ' ' '	'aaaABDZC'	False
	'aaaABdzxC'	False
	empty string	False

LIKE blank insignificant behavior subsystem parameter

When the LIKE_BLANK_INSIGNIFICANT subsystem parameter is enabled, all of the blanks at the end of a fixed-length string are ignored. This behavior is called *LIKE blank insignificant* behavior. *LIKE blank significant* behavior, in which the blanks at the end of fixed-length strings are significant (not ignored), is the default behavior during installation or migration. For variable length strings, blanks are significant.

When you set the LIKE_BLANK_INSIGNIFICANT subsystem parameter, LIKE blank insignificant behavior takes effect the next time an SQL query statement with the LIKE predicate is executed after the statement is bound or prepared. If the statement is not prepared or bound, the LIKE behavior exhibits LIKE blank significant behavior regardless of the subsystem parameter setting.

For the following interfaces, enabling or disabling LIKE blank insignificant behavior takes effect immediately. This applies to both an explicit LIKE predicate (for example, UNLOAD) and an implicit LIKE predicate (for example, table check constraint).

- INSERT
- UPDATE
- MERGE
- UNLOAD
- REORG
- LOAD
- CHECK DATA

Before the LIKE predicate is applied, any trailing blanks in a CHARACTER or GRAPHIC column are stripped to the last non-blank character. If the column contains all blanks, the blank in character position 1 is not stripped. After stripping occurs, the LIKE predicate is applied against the stripped column data.

Tip: After you enable the LIKE_BLANK_INSIGNIFICANT subsystem parameter, existing rows might not conform to table check constraints that contain a LIKE predicate. Consider running the CHECK DATA utility on all affected tables to find the records that do not conform to the table check constraint.

The following examples, in which *b* represents a blank character, demonstrate how the LIKE predicate is evaluated when LIKE blank insignificant behavior is enabled.

```
SELECT C1
FROM T1
WHERE C1 LIKE '%xyz';
```

This LIKE predicate will match the following fixed-length strings:

- abcxyz
- abcxyzb
- abcxyzbb
- abcxyzbb..b'

While trailing blanks in the column data are insignificant, trailing blanks in the LIKE predicate are significant. The following example, in which *b* represents a blank character, applies to when the LIKE predicate contains one or more trailing blanks.

```
SELECT C1
FROM T1
WHERE C1 LIKE '%xyzbb';
```

This LIKE predicate will not match the following fixed-length strings:

- *abcxyz*
- *abcxyzb*
- *abcxyzbb*
- *abcxyzbbb*

The following example applies to when the LIKE predicate contains one or more single characters (*_*) in the last position.

```
SELECT C1
FROM T1
WHERE C1 LIKE '%xyz_';
```

This LIKE predicate will not match the following fixed-length strings, because they are all stripped to the 'abcxyz' string:

- *abcxyz*
- *abcxyzb*
- *abcxyzbb*
- *abcxyzbb..b*

The following example applies to when the LIKE predicate contains more than one single character (*_*) in the last position.

```
SELECT C1
FROM T1
WHERE C1 LIKE '%xyz__';
```

This LIKE predicate will not match the following fixed-length strings:

- *abcxyz*
- *abcxyzb*
- *abcxyzbb*
- *abcxyzbb..b*

The following example applies to when the LIKE predicate contains more than one single character (*_*) and a string of zero or more characters (*%*) are in the last positions.

```
SELECT C1
FROM T1
WHERE C1 LIKE '%xyz_%_';
This
```

This LIKE predicate will not match the following fixed-length strings:

- *abcxyz*
- *abcxyzb*
- *abcxyzbb*
- *abcxyzbb..b*

If the column data contains all blanks, every blank, except the blank in character position one, is stripped before the LIKE predicate is applied. For example, a CHAR(6) column contains the following values:

bbbbbb

The following LIKE predicates will match:

- LIKE 'b'
- LIKE '_'
- LIKE '%'

The following LIKE predicates will not match:

- LIKE 'bbbbbbb'
- LIKE 'bbbb___'
- LIKE '_____'

Related reference

[LIKE_BLANK_INSIGNIFICANT](#) in macro DSN6SPRM (Db2 Installation and Migration)

NULL predicate

The NULL predicate tests for null values.

► expression — IS — NOT — NULL —►

The result of a NULL predicate cannot be unknown. If the value of the expression is null, the result is true. If the value is not null, the result is false. If NOT is specified, the result is reversed.

A parameter marker must not be specified for or within the expression.

Notes

Syntax alternatives:

FL 504 For compatibility with other SQL dialects, you can use ISNULL as an alternative syntax for IS NULL and NOTNULL as alternative syntax for IS NOT NULL.

Example 1: The following predicate is true whenever PHONENO has the null value, and is false otherwise.

```
PHONENO IS NULL
```

Example 2: The following predicate is true whenever the array MYARRAY has the null value, and is false otherwise.

```
MYARRAY IS NULL
```

XMLEXISTS predicate

The XMLEXISTS predicate tests whether an XQuery expression returns a sequence of one or more items.

► XMLEXISTS — (— xquery-expression-constant —►

PASSING — BY REF — xquery-argument 1 —►

Notes:

¹ *xquery-context-item-expression* must not be specified more than one time.

xquery-argument

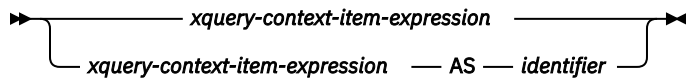

xquery-expression-constant

Specifies a character string constant that is interpreted as an XQuery expression using supported XQuery language syntax. For information about the XQuery language syntax, see [Overview of pureXML \(Db2 Programming for XML\)](#). *xquery-expression-constant* cannot be an XQuery updating expression. The XQuery expression is evaluated with the arguments specified in *xquery-argument*. *xquery-expression-constant* must not be an empty string or a string of all blanks.

PASSING

Specifies input values and the manner in which these values are passed to the XQuery expression specified by *xquery-expression-constant*.

BY REF

Specifies that the XML input value arguments are to be passed by reference. When XML values are passed by reference, the XQuery evaluation uses the input node trees, preserving all properties including the original node identities and document order. If two arguments pass the same XML value, node identity comparisons and document ordering comparisons that involve some nodes that are contained between the two input arguments might refer to nodes within the same XML node tree.

This clause has no impact on how non-XML values are passed. The non-XML values create a new copy of the value during the cast to XML.

xquery-argument

Specifies an argument to use in the evaluation of the XQuery expression specified by *xquery-expression-constant*. A query argument is an expression that returns a value that is XML, integer, decimal, or a character or graphic string that is not a LOB. *xquery-argument* must not return ROWID, TIMESTAMP, binary string, REAL, DECFLOAT data types, or a character string data type that is bit data, and must not reference a sequence expression or a *OLAP-specification*.

An argument specifies a value and the manner in which that value is to be passed. How an argument in the PASSING clause is used in the XQuery expression depends on whether the argument is specified as the *xquery-context-item-expression* or an *xquery-variable-expression*. The argument includes an SQL expression that is evaluated before passing the result to the XQuery expression.

- If the resulting value is an XML value, it becomes an *input-xml-value*. It is passed by reference which means that the original values, not copies, are used in the evaluation of the XQuery expression.
- If the resulting value is not an XML value, the result of the expression must be able to be cast to an XML value. The cast value becomes an *input-xml-value*. An empty string is converted to an XML empty string.
- If the resulting value is a null value, it is converted to an XML empty sequence if the argument is *xquery-variable-expression*. If the argument is *xquery-context-expression*, the `XMLEXISTS` predicates returns unknown.

xquery-context-item-expression

xquery-context-item-expression specifies the *initial context item* in the XQuery expression specified by *xquery-expression-constant*. The value of the initial context item is the result of *xquery-context-item-expression* cast to XML. *xquery-context-item-expression* must not be specified more than one time.

xquery-context-item-expression must not be a sequence of more than one item. If the result of *xquery-context-item-expression* is an empty string, the XQuery expression is evaluated with the initial context item set to an XML empty string.

If the *xquery-context-item-expression* is not specified or is an empty string, the initial context item in the XQuery expression is undefined, and the XQuery expression must not reference the initial context item. An XQuery variable is not created for the context item expression.

If the *xquery-context-expression* is not specified or the *input-xml-value* that results from the *xquery-context-expression* is an XML empty sequence, the initial context item is undefined. If the XQuery expression refers to the initial context item, it must be specified with a value that is not an XML empty sequence.

xquery-variable-expression

xquery-variable-expression specifies an argument to the XQuery expression. An XQuery variable is created for each *xquery-variable-expression*, and the XQuery variable is set to the result of *xquery-argument-expression* cast to XML. If the result of *xquery-variable-expression* is an empty string, the XQuery variable is set to an XML empty string. If *xquery-variable-expression* is null, the XQuery variable is set to an XML empty sequence. For example, `PASSING T.A + T.B as "sum"` creates an XQuery variable named `sum`. The scope of the XQuery variables created from the `PASSING` clause is the XQuery expression that is specified by *xquery-expression-constant*.

AS identifier

Specifies that the value that is generated by *xquery-variable-expression* will be passed to *xquery-expression-constant* as an XQuery variable named *identifier*. The length of the name must not be longer than 128 bytes. The leading dollar sign (\$) that precedes variable names in the XQuery language is not included in *identifier*. The name must be an XML NCName that is not the same as *identifier* for another *xquery-variable-expression* in the same `PASSING` clause.

The result of the predicate is determined as follows:

- The result is unknown if *xquery-context-item-expression* specified in the `PASSING` clause is a NULL value
- the result is false if the result of the XQuery expression is an empty sequence
- the result is true in all other cases

If the evaluation of the XQuery expression results in an error, `XMLEXISTS` returns an error. The `XMLEXISTS` predicate is not supported in `ON` clause of outer joins.

Example: Find all the purchase orders that buy a baby monitor. This example finds the product number for baby monitors from the product table and joins the result to the `PurchaseOrders` table. It then evaluates the XQuery expression `//item[@partnum = $n]` for each row and returns those rows that contain an item element node with a `partNum` attribute that is equal to the product number of 'Baby Monitor'. The context item for the XQuery expression is `PO.POrder`. An XQuery variable, `$n`, is created and initialized to the value of `S.prodno`:

```
SELECT S.prodno, count(*) as result
FROM PurchaseOrders PO, Products S
WHERE XMLEXISTS ('//item[@partNum = $n]'
                PASSING PO.POrder,
                        S.prodno AS "n")
AND S.prod_name = 'Baby Monitor';
```

The results might be similar to the following:

Prodno	result
926-AA	1

Search conditions

A *search condition* specifies a condition that is true, false, or unknown about a given row or group. When the condition is true, the row or group qualifies for the results. When the condition is false or unknown, the row or group does not qualify.

Syntax

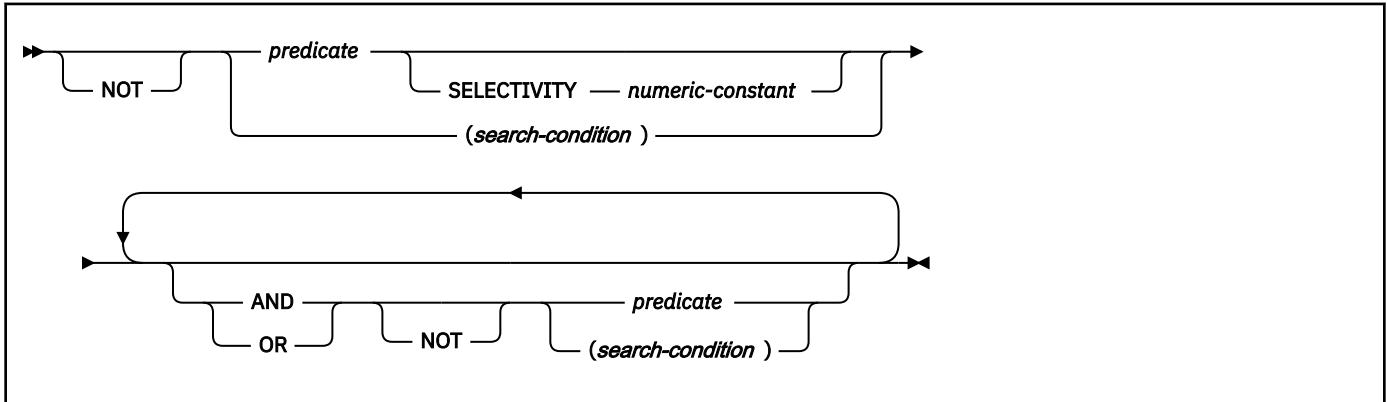

Description

SELECTIVITY numeric-constant

Specifies the expected selectivity percentage for the predicate. You can specify the `SELECTIVITY` clause only when the predicate contains one of the indexable spatial predicate functions and the predicate is in the form of *spatial-predicate-function operator expression*, where *operator* is either = or <. The selectivity value must be an integer or decimal constant value in the range in the range 0–1 (inclusive). For example, if you specify 0.01, the spatial predicate function is expected to filter out all but one percent of all the rows in the table. An error is returned if the `SELECTIVITY` clause is specified for a non-spatial predicate function.

The result of a search condition is derived by application of the specified *logical operators* (`AND`, `OR`, `NOT`) to the result of each specified predicate. If logical operators are not specified, the result of the search condition is the result of the specified predicate.

`AND` and `OR` are defined in the following table, in which *P* and *Q* are any predicates:

Table 63. Truth table for `AND` and `OR`

<i>P</i>	<i>Q</i>	<i>P and Q</i>	<i>P or Q</i>
True	True	True	True
True	False	False	True
True	Unknown	Unknown	True
False	True	False	True
False	False	False	False
False	Unknown	False	Unknown
Unknown	True	Unknown	True
Unknown	False	False	Unknown
Unknown	Unknown	Unknown	Unknown

`NOT(true)` is false and `NOT(false)` is true, but `NOT(unknown)` is still unknown. The `NOT` logical operator has no affect on an unknown condition. The result of `NOT(unknown)` is still unknown.

Search conditions within parentheses are evaluated first. If the order of evaluation is not specified by parentheses, NOT is applied before AND, and AND is applied before OR. The order in which operators at the same precedence level are evaluated is undefined to allow for optimization of search conditions.

Example 1: In the first of the search conditions below, AND is applied before OR. In the second, OR is applied before AND.

```
SALARY>:SS AND COMM>:CC OR BONUS>:BB
SALARY>:SS AND (COMM>:CC OR BONUS>:BB)
```

Example 2: In the first of the search conditions below, NOT is applied before AND. In the second, AND is applied before NOT.

```
NOT SALARY>:SS AND COMM>:CC
NOT (SALARY>:SS AND COMM>:CC)
```

Example 3: For the following search condition, AND is applied first. After the application of AND, the OR operators could be applied in either order without changing the result. Db2 can therefore select the order of applying the OR operators.

```
SALARY>:SS AND COMM>:CC OR BONUS>:BB OR SEX=:GG
```

Options affecting SQL

Certain Db2 precompiler or coprocessor options (referred to as SQL processing options), Db2 subsystem parameters (set through the installation panels), bind options, options for CREATE PROCEDURE and ALTER PROCEDURE statements for native SQL procedures, and special registers affect how SQL statements can be composed or determine how SQL statements are processed.

The following table summarizes the effect of these options and shows where to find more information. (Some of the items are described in detail following the table, while other items are described elsewhere.)

Table 64. Summary of items affecting composition and processing of SQL statements

SQL processing option	Other ¹	Affects
	DYNAMICRULES bind option or the native SQL procedures option	The rules that Db2 applies to dynamic SQL statements. For details about authorization, see “Authorization IDs and dynamic SQL” on page 94. The option can also affect decimal point representation, string delimiters, and decimal arithmetic. For details about how Db2 applies the options to dynamic SQL statements when DYNAMICRULES bind, define, or invoke behavior is in effect, see “SQL processing options for dynamic statements” on page 322.
	USE FOR DYNAMICRULES	Use of options for dynamic statements when DYNAMICRULES bind, define, or invoke behavior is in effect. For details, see “SQL processing options for dynamic statements” on page 322.
COMMA PERIOD	DECIMAL POINT IS	Representation of decimal points in SQL statements. For details, see “Decimal point representation” on page 323.

Table 64. Summary of items affecting composition and processing of SQL statements (continued)

SQL processing option	Other ¹	Affects
APOSTSQL QUOTESQL	SQL STRING DELIMITER	Representation of string delimiters in SQL statements. For details, see “Apostrophes and quotation marks as string delimiters” on page 324.
	ASCII CCSID	A numeric value that determines the CCSID of ASCII string data. For details, see “Mixed data in character strings” on page 325.
	EBCDIC CCSID	A numeric value that determines the CCSID of EBCDIC string data and whether Katakana characters can be used in ordinary identifiers. For details, see “Katakana characters for EBCDIC” on page 325.
	UNICODE CCSID	A numeric value that determines the CCSID of Unicode string data. For details, see “Mixed data in character strings” on page 325.
CCSID	MIXED DATA	Use of ASCII or EBCDIC character strings with a mixture of SBCS and DBCS characters. For details, see “Mixed data in character strings” on page 325.
DATE TIME	DATE FORMAT TIME FORMAT LOCAL DATE LENGTH LOCAL TIME LENGTH	Formatting of datetime strings. For details, see “Formatting of datetime strings” on page 325.
STDSQL		Conformance with the SQL standard. For details, see “SQL standard language” on page 326.
NOFOR or STDSQL		Whether the FOR UPDATE clause must be specified (in the SELECT statement of the DECLARE CURSOR statement). For details, see “Positioned updates of columns” on page 326.
CONNECT		Whether the rules for the CONNECT(1) or CONNECT(2) SQL processing option apply. For details about the SQL processing option, see Descriptions of SQL processing options (Db2 Application programming and SQL) .
	SQLRULES bind option	Whether a CONNECT statement is processed with Db2 rules or SQL standard rules.

Table 64. Summary of items affecting composition and processing of SQL statements (continued)

SQL processing option	Other ¹	Affects
	CURRENT RULES special register	<p>Whether the statements ALTER TABLE, CREATE TABLE, GRANT, and REVOKE are processed with Db2 rules or SQL standard rules. For details, see “CURRENT RULES special register” on page 205.</p> <p>Whether Db2 automatically creates the LOB table space, auxiliary table, and index on the auxiliary table for a LOB column in a base table. For details, see Creating a table with LOB columns.</p> <p>Whether Db2 automatically creates an index on a ROWID column that is defined with GENERATED BY DEFAULT. For details, see the description of the clause for “CREATE TABLE statement” on page 1650.</p> <p>Whether an external stored procedure runs as a main or subprogram. For details, see “CREATE PROCEDURE statement (external procedure)” on page 1580.</p>
	SQLRULES bind option or CURRENT RULES special register	Whether SQLCODE +236 is issued when the SQLDA provided on DESCRIBE or PREPARE INTO is too small and the result columns do not involve LOBs or distinct types. For details, see “DESCRIBE statement” on page 1869 and Appendix G, “SQL descriptor area (SQLDA)” on page 2313.
DEC	DECIMAL ARITHMETIC or CURRENT PRECISION special register	<p>Whether DEC15 or DEC31 rules are used when both operands in a decimal operation have 15 digits or less.</p> <p>For details, see “Arithmetic with two decimal operands” on page 251.</p>

Note: ¹ The entries in this column are fields on installation panels unless otherwise noted.

Related concepts

[Options for SQL statement processing \(Db2 Application programming and SQL\)](#)

SQL processing options for dynamic statements

Generally, dynamic statements use the application programming defaults specified on installation panel DSNTIPF. However, if the value of installation panel field USE FOR DYNAMICRULES is NO and DYNAMICRULES bind, define, or invoke behavior is in effect, certain SQL processing options are used instead of the application programming defaults.

The following SQL processing options are used instead of the application programming defaults:

- COMMA or PERIOD
- APOST or QUOTE
- APOSTSQL or QUOTESQL
- DEC(15) or DEC(31)

For some languages, the SQL processing option defaults to a value and no alternative is allowed. If the value of installation panel field USE FOR DYNAMICRULES is YES, dynamic statements use the application programming defaults regardless of the value of DYNAMICRULES option.

For additional information on the effect of SQL processing options and application programming defaults on:

- Decimal point representation, see [“Decimal point representation”](#) on page 323.
- String delimiters, see [“Apostrophes and quotation marks as string delimiters”](#) on page 324.
- Decimal arithmetic, see [“Arithmetic with two decimal operands”](#) on page 251.

For a list of the DYNAMICRULES option values that specify run, bind, define, or invoke behavior, see [Table 14 on page 94](#).

DECFLOAT rounding mode

All views and SQL functions referenced in an SQL statement must either not have rounding mode information stored in the SYSENVIRONMENT catalog, or they must all have the same rounding mode information in the SYSENVIRONMENT catalog.

Decimal point representation

Decimal points in SQL statements are represented with either periods or commas.

Two values control the representation:

- The value of field DECIMAL POINT IS on installation panel DSNTIPF, which can be a comma (,) or period (.)
- COMMA or PERIOD, which are mutually exclusive SQL processing options for COBOL

These values apply to SQL statements as follows:

- For a distributed operation, the decimal point is the first of the following values that applies:
 - The decimal point value specified by the requester
 - The value of field DECIMAL POINT IS on panel DSNTIPF at the Db2 where the package is bound
- Otherwise:
 - For static SQL statements:
 - In a COBOL program, the SQL processing option COMMA or PERIOD determines the decimal point representation for every static SQL statement. If neither SQL processing option is specified, the value of DECIMAL POINT IS at precompilation time determines the representation.
 - In non-COBOL programs, the decimal representation for static SQL statements is always the period.
 - For dynamic SQL statements:
 - If DYNAMICRULES run behavior applies, the decimal point is the value of field DECIMAL POINT IS on installation panel DSNTIPF at the local Db2 when the statement is prepared.

For a list of the DYNAMICRULES option values that specify run, bind, define, or invoke behavior, see [Table 14 on page 94](#).

- If DYNAMICRULES bind, define, or invoke behavior applies, and the value of installation panel field USE FOR DYNAMICRULES is YES, the decimal point is the value of field DECIMAL POINT IS.

If bind, define, or invoke behavior applies, and field USE FOR DYNAMIC RULES is NO, the SQL processing option determines the decimal point representation. For COBOL programs, which supports SQL processing option COMMA or PERIOD, the decimal point representation is determined as described above for static SQL statements in COBOL programs. For programs written in other host languages, the default SQL processing option, which can only be PERIOD, is used.

If the comma is the decimal point, these rules apply:

- In any context, a comma intended as a separator must be followed by a space. Such commas could appear, for example, in a VALUES clause, an IN predicate, or an ORDER BY clause in which numbers are used to identify columns.
- In any context, a comma intended as a decimal point must not be followed by a space.

- If the DECIMAL POINT IS field (and not the SQL processing option) determines the comma as the decimal point, Db2 will recognize either a comma or a period as the decimal point in numbers in dynamic SQL.

Related reference

[DECIMAL POINT IS field \(DECIMAL DECP value\) \(Db2 Installation and Migration\)](#)

[DYNAMICRULES bind option \(Db2 Commands\)](#)

Apostrophes and quotation marks as string delimiters

SQL processing options and Db2 installation panel fields control the representation of string delimiters in COBOL and SQL statements.

The following SQL processing options control the representation of string delimiters:

- APOST and QUOTE are mutually exclusive SQL processing options for COBOL. Their meanings are exactly what they are for the COBOL compilers:

- APOST names the apostrophe (') as the string delimiter in COBOL statements.
- QUOTE names the quotation mark (") as the string delimiter.

Neither option applies to SQL syntax. Do not confuse them with the APOSTSQL and QUOTESQL options.

- APOSTSQL and QUOTESQL are mutually exclusive SQL processing options for COBOL. Their meanings are:
 - APOSTSQL names the apostrophe (') as the string delimiter and the quotation mark (") as the escape character in SQL statements.
 - QUOTESQL names the quotation mark (") as the string delimiter and the apostrophe (') as the escape character in SQL statements.

These values apply to SQL statements as follows:

- For a distributed operation, the string delimiter is the first of the following values that applies:
 - The SQL string delimiter value specified by the requester
 - The value of the field SQL STRING DELIMITER on installation panel DSNTIPF at the Db2 where the package is bound
- Otherwise:
 - For static SQL statements:

In a COBOL program, the SQL processing option APOSTSQL or QUOTESQL determines the string delimiter and escape character. If neither SQL processing option is specified, the value of field SQL STRING DELIMITER on installation panel DSNTIPF determines the string delimiter and escape character.

In a non-COBOL program, the string delimiter is the apostrophe, and the escape character is the quotation mark.

- For dynamic SQL statements:
 - If DYNAMICRULES run behavior applies, the string delimiter and escape character is the value of field SQL STRING DELIMITER on installation panel DSNTIPF at the local Db2 when the statement is prepared.

For a list of the DYNAMICRULES option values that specify run, bind, define, or invoke behavior, see [Table 14 on page 94](#).

- If DYNAMICRULES bind, define, or invoke behavior applies and the value of installation panel field USE FOR DYNAMICRULES is YES, the string delimiter and escape character is the value of field SQL STRING DELIMITER.

If bind, define, or invoke behavior applies and USE FOR DYNAMICRULES is NO, the SQL processing option determines the string delimiter and escape character. For COBOL programs, SQL processing option APOSTSQL or QUOTESQL determines the string delimiter and escape character. If neither

SQL processing option is specified, the value of field SQL STRING DELIMITER determines them. For programs written in other host languages, the default SQL processing option, which can only be APOSTSQL, determines the string delimiter and escape character.

Katakana characters for EBCDIC

Ordinary identifiers with an EBCDIC encoding scheme can contain Katakana characters if the Db2 installation is set to allow it.

The field EBCDIC CCSID on installation panel DSNTIPF determines the system CCSIDs for EBCDIC-encoded data. Ordinary identifiers with an EBCDIC encoding scheme can contain Katakana characters if the field contains the value 5026 or 930. There are no corresponding SQL processing options. EBCDIC CCSID applies equally to static and dynamic statements. For dynamically prepared statements, the applicable value is always the one at the local Db2.

Mixed data in character strings

Mixed character data and graphic data are always allowed for Unicode, but for EBCDIC and ASCII, the specific installation of Db2 determines whether mixed data can be used.

The field MIXED DATA on installation panel DSNTIPF can have the value YES or NO for ASCII or EBCDIC character strings. The value YES indicates that character strings can contain a mixture of SBCS and DBCS characters. The value NO indicates that they cannot. Mixed character data and graphic data are always allowed for Unicode; that is the MIXED DATA field does not have an effect on Unicode data.

For static SQL statements, the value of the CCSID SQL processing option or the derived CCSID for the Db2 coprocessor determines whether ASCII or EBCDIC character strings can contain mixed data. If a mixed CCSID is used, mixed strings are allowed. If a single-byte CCSID is used, mixed strings are not allowed.

For dynamic SQL statements, the CCSID that is selected to convert the dynamic statement text to UTF-8 determines whether ASCII or EBCDIC character strings can contain mixed data. The CCSID for a dynamic statement is determined from the SQLDA override (if any) for the host variable on the PREPARE statement, the value of the CURRENT ENCODING SCHEME special register, and the ENCODING bind option.

The value of MIXED DATA affects the parsing of SQL character string constants, the execution of the LIKE predicate, and the assignment of character strings to host variables when truncation is needed. It can also affect concatenation, as explained in [“Concatenation operators in expressions”](#) on page 247. A value that applies to a statement executed at the local Db2 also applies to any statement executed at another server. An exception is the LIKE predicate, for which the applicable value of MIXED DATA is always the one at the statement's server.

The value of MIXED DATA also affects the choice of system CCSIDs for the local Db2 and the choice of data subtypes for character columns. When this value is YES, multiple CCSIDs are available for ASCII and EBCDIC data (SBCS, DBCS, and MIXED). The CCSID specified in the ASCII CCSID or EBCDIC CCSID field is the MIXED CCSID. In this case, Db2 derives the SBCS and MIXED CCSIDs from the DBCS CCSID specified installation panel DSNTIPF. Moreover, a character column can have any one of the allowable data subtypes—BIT, SBCS, or MIXED.

On the other hand, when MIXED DATA is NO, the only ASCII or EBCDIC system CCSIDs are those for SBCS data. Therefore, only BIT and SBCS can be data subtypes for character columns.

Formatting of datetime strings

The format for a datetime string that is in effect for a statement that is executed at the local Db2 is not necessarily in effect for a statement that is executed at a different server.

Fields on installation panel DSNTIP4 (DATE FORMAT, TIME FORMAT, LOCAL DATE LENGTH, and LOCAL TIME LENGTH) and SQL processing options affect the formatting of datetime strings.

The formatting of datetime strings is described in [“String representations of datetime values”](#) on page 120. Unlike the subsystem parameters and options previously described, a value in effect for a statement

executed at the local Db2 is not necessarily in effect for a statement executed at a different server. See [“Restrictions on the use of local datetime formats” on page 124](#) for more information.

SQL standard language

Db2 SQL and the SQL standard are not identical. The STDSQL SQL processing option addresses some of the differences.

- STDSQL(NO) indicates that conformance with the SQL standard is not intended. The default is the value of field STD SQL LANGUAGE on installation panel DSNTIP4 (which has a default of NO).
- STDSQL(YES)¹⁶ indicates that conformance with the SQL standard is intended.

When a program is precompiled with the STDSQL(YES) option, the following rules apply:

Declaring host variables: All host variable declarations except in Java and REXX must lie between pairs of BEGIN DECLARE SECTION and END DECLARE SECTION statements:

```
BEGIN DECLARE SECTION
-- one or more host variable declarations
END DECLARE SECTION
```

Separate pairs of these statements can bracket separate sets of host variable declarations.

Declarations for SQLCODE and SQLSTATE: The programmer must declare host variables for either SQLCODE or SQLSTATE, or both. SQLCODE should be defined as a fullword integer and SQLSTATE should be defined as a 5-byte character string. SQLCODE and SQLSTATE cannot be part of any structure. The variables must be declared in the DECLARE SECTION of a program; however, SQLCODE can be declared outside of the DECLARE SECTION when no host variable is defined for SQLSTATE. For PL/I, an acceptable declaration can look like this:

```
DECLARE SQLCODE BIN FIXED(31);
DECLARE SQLSTATE CHAR(5);
```

In Fortran programs, the variable SQLCOD should be used for SQLCODE, and either SQLSTATE or SQLSTA can be used for SQLSTATE.

Definitions for the SQLCA: An SQLCA must not be defined in your program, either by coding its definition manually or by using the INCLUDE SQLCA statement. When STDSQL(YES) is specified, the Db2 precompiler or coprocessor automatically generates an SQLCA that includes the variable name SQLCADE instead of SQLCODE and SQLSTAT instead of SQLSTATE. After each SQL statement executes, Db2 assigns status information to SQLCODE and SQLSTATE, whose declarations are described above, as follows:

- SQLCODE: Db2 assigns the value in SQLCADE to SQLCODE. In Fortran, SQLCAD and SQLCOD are used for SQLCADE and SQLCODE, respectively.
- SQLSTATE: Db2 assigns the value in SQLSTAT to SQLSTATE. (In Fortran, SQLSTT and SQLSTA are used for SQLSTAT and SQLSTATE, respectively.)
- No declaration for either SQLSTATE or SQLCODE: Db2 assigns the value in SQLCADE to SQLCODE.

If the precompiler or coprocessor encounters an INCLUDE SQLCA statement, it ignores the statement and issues a warning message. The precompiler or coprocessor also does not recognize hand-coded definitions, and a hand-coded definition creates a compile-time conflict with the generated definition. A similar conflict arises if definitions of SQLCADE or SQLSTAT, other than the ones generated by the Db2 precompiler or coprocessor, appear in the program.

Positioned updates of columns

Certain SQL processing options affect the use of the FOR UPDATE clause to achieve positioned column updates.

The NOFOR SQL processing option affects the use of the FOR UPDATE clause. The NOFOR option is in effect when either of the following are true:

¹⁶ STDSQL(86) is a synonym, but STDSQL(YES) should be used.

- The NOFOR option is specified.
- The STDSQL(YES) option is in effect.

Otherwise, the NOFOR option is not in effect. The following table summarizes the differences when the option is in effect and when the option is not in effect:

Table 65. The NOFOR SQL processing option

When NOFOR is in effect	When NOFOR is not in effect
The use of the FOR UPDATE clause in the SELECT statement of the DECLARE CURSOR statement is optional. This clause restricts updates to the specified columns and causes the acquisition of update locks when the cursor is used to fetch a row. If no columns are specified, positioned updates can be made to any updatable columns in the table or view that is identified in the first FROM clause in the SELECT statement. If the FOR UPDATE clause is not specified, positioned updates can be made to any columns that the program has Db2 authority to update.	The FOR UPDATE clause must be specified.
DBRMs must be built entirely in virtual storage, which might possibly increase the virtual storage requirements of the Db2 precompiler or coprocessor. However, creating DBRMs entirely in virtual storage might cause concurrency problems with DBRM libraries.	DBRMs can be built incrementally using the Db2 precompiler or coprocessor.

SQL processing options do not affect ODBC behavior.

Mappings from SQL to XML

Db2 maps SQL to XML data according to industry standards and performs several different mappings.

To construct XML data from SQL data, the following mappings are performed:

- SQL character sets to XML character sets
- SQL identifiers to XML names
- SQL data values to XML data values

Db2 maps SQL to XML data according to industry standards. For complete information, see *Information technology - Database languages - SQL - Part 14: XML-Related Specifications (SQL/XML) ISO/IEC 9075-14:2003*.

Mapping SQL character sets to XML character sets

The character set used for XML data is Unicode UTF-8. SQL character data is converted into Unicode when it is used in XML built-in functions.

Mapping SQL identifiers to XML names

Many SQL identifiers that contain certain characters must be escaped when the SQL identifier is converted into an XML name.

Strings that start with 'XML', in any case combination, are reserved for standardization, and characters such as '#', '{', and '}' are not allowed in XML names. Many SQL identifiers containing these characters need to be escaped when the SQL identifiers are converted into XML names.

Db2 applies full escaping to SQL identifiers that are column names when it derives XML names. The mapping converts a colon (:) to `_x003A_`, `_x` to `_x005F_x`, and other restricted characters to a string of the form `_xuuuu_` where `uuuu` is the Unicode value for the character. An identifier with an initial 'XML' (in any case combination) is escaped by mapping the initial `x` to `_x0078_`, or the initial `X` to `_x0058_`.

Mapping SQL data values to XML data values

SQL data values are mapped to XML values based on SQL data types.

The following data types are not supported and cannot be used as arguments to XML value constructors:

- ROWID
- Character strings that are defined with the FOR BIT DATA attribute
- Binary strings
- A string or a binary string distinct type that is based on a ROWID, FOR BIT DATA character string, or BLOB

For supported data types, the encoding scheme for XML values is Unicode.

Chapter 3. Built-in global variables and session variables

Db2 provides several built-in session variables and built-in global variables.

Built-in session variables contain information about the server and application process. Built-in global variables contain information about the database manager.

Built-in global variables

Built-in global variables are provided with the database manager and are used in SQL statements to retrieve scalar values associated with the variables.

As an example, the SYSIBM.PRODUCTID_EXT built-in global variable is referenced in an SQL statement to retrieve the extended product identifier of the database manager that invoked a function.

Authorization

The authorization ID of any statement that retrieves the value of the global variable is required to have one of the following:

- The READ privilege on that global variable
- DATAACCESS authority
- SYSADM authority

The READ privilege is granted to PUBLIC for built-in global variables, unless RACF external security is in use.

The authorization ID of any statement that assigns a value to a global variable is required to have one of the following:

- The WRITE privilege on that global variable
- DATAACCESS authority
- SYSADM authority

The WRITE privilege is not granted to PUBLIC for built-in global variables. The GRANT (variable privileges) statement can be used to grant the WRITE privilege to other users.

CATALOG_LEVEL

Contains the current catalog level.

This global variable has the following characteristics:

- It is read only, with values maintained by the system.
- The type is VARCHAR(30).
- The schema is SYSIBM.
- The scope of this global variable is session.

The format is *VvvvRrMmmm*, where *vv* is the version, *r* is the release, and *mmm* is the modification level. For example, V12R1M510 identifies function level 510. For a list of all available function levels in Db2 12, see [Db2 12 function levels \(Db2 for z/OS What's New?\)](#).

Values V10R1 and V11R1 are also supported.

CLIENT_IPADDR

Contains the value of the client IP address for the connection.

For remote client connections, the value is the host IP address of the application that is used to establish the connection. For local host applications, the value is NULL. For remote host applications, the value is the IP address that is associated with the Db2 subsystem used to establish the connection as shown by issuing the `-DISPLAY DDF` command.

This global variable has the following characteristics:

- It is read only, with values maintained by the system.
- The type is CHAR(39).
- The schema is SYSIBM.
- The scope of this global variable is session.

The value is set by Db2 as obtained from the network. If the client did not connect by using the TCP/IP or SSL protocol, the value of the global variable is NULL.

```
1111:2222:3333:4444:5555:6666:7777:8888
```

Or IPv4-mapped IPv6 format:

```
::FFFF:9.30.115.135
```

Related reference

[-DISPLAY DDF command \(Db2\) \(Db2 Commands\)](#)

Related information

[DSNL085I \(Db2 Messages\)](#)

[DSNL089I \(Db2 Messages\)](#)

DEFAULT_SQLLEVEL

Contains the value of the default value of the SQLLEVEL SQL processing option (DECPSQLL).

This global variable has the following characteristics:

- It is read only, with values maintained by the system.
- The type is VARCHAR(30)
- The schema is SYSIBM.
- The scope of this global variable is session.

The format is `VvvvRrMmmm`, where `vv` is the version, `r` is the release, and `mmm` is the modification level. For example, `V12R1M510` identifies function level 510. For a list of all available function levels in Db2 12, see [Db2 12 function levels \(Db2 for z/OS What's New?\)](#).

GET_ARCHIVE

Contains a string value that indicates whether a reference to an archive-enabled table in a table-reference should include rows in the associated archive table.

This global variable has the following characteristics:

- It is updatable, with values maintained by the user.
- The type is CHAR(1).
- The schema is SYSIBMADM.
- The scope of this global variable is session.

The global variable can be set to the following:

Y

Specifies that when a table-reference is an archive-enabled table, the table reference includes rows in the associated archive table.

If the SYSIBMADM.GET_ARCHIVE global variable is set to 'Y' and the ARCHIVESENSITIVE bind option is set to 'Y', an archive-enabled table cannot be referenced in an SQL table function or in the definition of a row permission or column mask that is activated by a data change statement or query.

N

Specifies that when a table-reference is an archive-enabled table, the table reference does not include rows in the associated archive table. This is the default value.

Related concepts

[Archive-enabled tables and archive tables \(Introduction to Db2 for z/OS\)](#)

Related reference

[table-reference](#)

A *table-reference* specifies a result table as either a table or view, or an intermediate table.

MAX_LOCKS_PER_TABLESPACE

Contains a big integer value that specifies the default maximum number of page, row, or LOB locks that an application can simultaneously hold in a table space.

[FL 507](#)

If a single application exceeds the maximum number of locks in a single table space, lock escalation occurs.

The value that you specify for this field must be less than the value of the MAX_LOCKS_PER_USER built-in global variable (except when MAX_LOCKS_PER_USER is set to 0).

This global variable has the following characteristics:

- It is updatable, with values maintained by the user.
- The type is BIGINT.
- The schema is SYSIBMADM.
- The scope of this global variable is session.
- The default value is determined from the NUMLKTS subsystem parameter at the start of the application. Any subsequent changes to the NUMLKTS subsystem parameter do not affect the value of MAX_LOCKS_PER_TABLESPACE. You can use either of the following SET assignment statements to reinitialize MAX_LOCKS_PER_TABLESPACE using the current value of the NUMLKTS subsystem parameter:

```
SET SYSIBMADM.MAX_LOCKS_PER_TABLESPACE = DEFAULT;
```

```
SET SYSIBMADM.MAX_LOCKS_PER_TABLESPACE = NULL;
```

- The acceptable range of values is 0–104857600

Related reference

[LOCKS PER TABLE\(SPACE\) field \(NUMLKTS subsystem parameter\) \(Db2 Installation and Migration\)](#)

[LOCKS PER USER field \(NUMLKUS subsystem parameter\) \(Db2 Installation and Migration\)](#)

MAX_LOCKS_PER_USER

Contains a big integer value that specifies the maximum number of page, row, or LOB locks that a single application can concurrently hold for all table spaces.

[FL 507](#)

MAX_LOCKS_PER_USER has the following characteristics:

- It is updatable, with values maintained by the user.
- The type is BIGINT.
- The schema is SYSIBMADM.
- The scope of this global variable is session.
- The default value is determined from the NUMLKUS subsystem parameter at the start of the application. Any subsequent changes to the NUMLKUS subsystem parameter do not affect the value of MAX_LOCKS_PER_USER. You can use either of the following SET assignment statements to reinitialize MAX_LOCKS_PER_USER using the current value of the NUMLKUS subsystem parameter:

```
SET SYSIBMADM.MAX_LOCKS_PER_USER = DEFAULT;
```

```
SET SYSIBMADM.MAX_LOCKS_PER_USER = NULL;
```

- The acceptable range of values is 0–104857600

Related reference

[LOCKS PER USER field \(NUMLKUS subsystem parameter\) \(Db2 Installation and Migration\)](#)

MOVE_TO_ARCHIVE

Contains a string value that indicates whether the deletion of a row of an archive-enabled table should result in storing a copy of the deleted row in the associated archive table.

This global variable has the following characteristics:

- It is updatable, with values maintained by the user.
- The type is CHAR(1).
- The schema is SYSIBMADM.
- The scope of this global variable is session.

The global variable can be set to the following:

Y

Specifies that a delete of a row in an archive-enabled table will result in storing a copy of the deleted row in the associated archive table. Additionally, when the global variable is set to 'Y', an insert or update operation that specifies the archive-enabled table as the target of the statement will return an error.

E

Specifies that a delete of a row in an archive-enabled table will result in storing a copy of the deleted row in the associated archive table.

N

Specifies that a delete of a row in an archive-enabled table will not result in storing a copy of a deleted row in the associated archive table.

The default value is determined from the value of the MOVE_TO_ARCHIVE_DEFAULT subsystem parameter in macro DSN6SPRM.

Related concepts

[Archive-enabled tables and archive tables \(Introduction to Db2 for z/OS\)](#)

PRODUCTID_EXT

Contains the extended product identifier of the database manager that invoked the function.

This global variable has the following characteristics:

- It is read only, with values maintained by the system.
- The type is VARCHAR(30).
- The schema is SYSIBM

- The scope of this global variable is session.

The format of extended product identifier values is *pppvrrmmm*, where *ppp* is a 3-letter product code (such as DSN for Db2 for z/OS), *vv* is the version, *rr* is the release, and *mmm* is the modification level. For example, DSN1201510 represents Db2 12 at the highest released function level.

REPLICATION_OVERRIDE

Indicates whether Db2 is to disable recording of temporal history for a system-period temporal table and allow an application to specify values for row-begin, row-end, transaction-start-ID, and generated expression columns.

PSPI

FL 503 The global variable does not affect new values for row-begin, row-end, transaction-start-ID, and generated expression columns that are not explicitly specified as the target of an assignment clause for a data change statement. Db2 continues to generate values for these columns in other contexts.

This global variable has the following characteristics:

- It is updatable, with values maintained by the user.
- The type is CHAR(1).
- The schema is SYSIBMADM.
- The scope of this global variable is session.
- The default value is 'N'

The global variable can be set to the following:

N

An application is not allowed to specify values for row-begin, row-end, transaction-start-ID, and generated expression columns. The recording of temporal history for a system-period temporal table is enabled.

N is the default.

Y

An application is allowed to specify values for row-begin, row-end, transaction-start-ID, and generated expression columns. The recording of temporal history for a system-period temporal table is disabled.

The REPLICATION_OVERRIDE built-in global variable is not intended for general use. It is intended for use by products that enable Db2 replication. The READ privilege on the variable is granted to PUBLIC. The WRITE privilege on the variable is not granted to PUBLIC.

Setting the SYSIBMADM.REPLICATION_OVERRIDE built-in global variable to 'Y' overrides the following default behaviors:

- Row-begin, row-end, transaction-start-ID, and generated expression columns are normally defined so that Db2 always generates the values. When the override is in effect, insert or update operations can specify values for row-begin, row-end, transaction-start-ID, or generated expression columns.
- Update and delete operations for system-period temporal tables normally generate historical rows. When the override is in effect, historical rows are not written to the associated history table for update and delete operations.

PSPI

Related reference

[SET_MAINT_MODE_RECORD_NO_TEMPORALHISTORY stored procedure](#)

TEMPORAL_LOGICAL_TRANSACTION_TIME

Contains the value that is assigned to the row-begin column of a system-period temporal table, or to the end column in a history table during an insert, update, or delete operation.

This global variable has the following characteristics:

- It is updatable, with values maintained by the user or the system.
- The type is `TIMESTAMP(12) WITHOUT TIME ZONE`.
- The schema is `SYSIBM`.
- The scope of this global variable is session.

The global variable can be set to the following:

NULL

Specifies that temporal logical transactions are not in use. This is the default value. Db2 ensures the uniqueness of the generated values for row-begin columns in system-period temporal tables, and end columns in history tables across transactions, assuming that temporal logical transactions have not been used. If multiple rows are inserted or updated in system-period temporal tables within a single SQL unit of work, the values for the row-begin columns are the same for all of the rows and are unique from the values that are generated for the columns by another transaction. If a conflicting unit of work is updating the same row in the system-period temporal table, and the row to be inserted into the associated history table would have an end timestamp value greater than the begin timestamp value, an error is returned. If the begin timestamp value and end timestamp value for the row in the history table are the same, a row is not inserted into the history table.

Non-null value

Specifies a timestamp value to start a new temporal logical transaction. It is recommended that the value be later in time than the existing value of the global variable.

While the `SYSIBM.TEMPORAL_LOGICAL_TRANSACTION_TIME` built-in global variable is set to a non-null value, the application controls the scope of temporal logical transactions. Db2 does not ensure the uniqueness of the generated values for row-begin columns in system-period temporal tables, and end columns in history tables across transactions.

When the `TEMPORAL_LOGICAL_TRANSACTION_TIME` global variable is set to 0, within a unit of work, a single assignment of a non-null value can be made to the global variable.

The variable must not be assigned a value in the body of a before trigger.

The variable must not be assigned a non-null value if values have been assigned to row-begin columns or transaction-start-ID columns within the same unit of work.

During the execution of a data change operation, the value of the `TEMPORAL_LOGICAL_TRANSACTION_TIME` built-in global variable is the value established at the beginning of the data change statement.

TEMPORAL_LOGICAL_TRANSACTIONS

Specifies whether multiple temporal logical transactions are allowed within a single unit of work.

This global variable has the following characteristics:

- It is updatable, with values maintained by the user or the system.
- The type is `SMALLINT`.
- It is `NOT NULL`.
- The schema is `SYSIBM`.
- The scope of this global variable is session.

The global variable can be set to the following:

0

Disallows multiple temporal logical transactions in a single unit of work. This is the default value.

Allows multiple temporal logical transactions in a single unit of work.

Rules for setting built-in global variables by using profile tables

In remote applications, some built-in global variables can be set with a value from the profile attributes table. When you set built-in global variables through the profile attributes table, be aware of the following rules and behavior.

You can set the following built-in global variables by specifying the GLOBAL_VARIABLE value for the KEYWORDS column in the DSN_PROFILE_ATTRIBUTES table. For detailed instructions, see [Setting built-in global variables by using profile tables \(Db2 Administration Guide\)](#).

Global variable	Examples
“GET_ARCHIVE” on page 330	SET SYSIBMADM.GET_ARCHIVE = 'Y'
FL 507 “MAX_LOCKS_PER_TABLESPACE” on page 331	SET SYSIBMADM.MAX_LOCKS_PER_TABLESPACE = NULL
FL 507 “MAX_LOCKS_PER_USER” on page 331	SET SYSIBMADM.MAX_LOCKS_PER_USER = DEFAULT
“MOVE_TO_ARCHIVE” on page 332	SET SYSIBMADM.MOVE_TO_ARCHIVE = 'N'
“TEMPORAL_LOGICAL_TRANSACTION_TIME” on page 334	SET SYSIBM.TEMPORAL_LOGICAL_TRANSACTION_TIME = '2014-11-14-08.05.01.123456789'
“TEMPORAL_LOGICAL_TRANSACTIONS” on page 334	SET SYSIBM.TEMPORAL_LOGICAL_TRANSACTIONS = 0

The following rules apply to SET statements for built-in global variables in the DSN_PROFILE_ATTRIBUTES table:

- The schema qualifier of the variable must be specified.
- The SET statement must have an equal sign (=) between the global variable name and the value that is assigned.
- Variable names can be specified in mixed case. Extraneous blanks between keywords are removed.
- The value that is specified for assignment must be valid for the variable and must not be an expression, or reference other special registers or variables.
- The value that is specified for assignment is passed through this interface as a string constant. For example, if a value to be assigned is the same as the name of a special register, Db2 stores the special register name, and not the special register value.
- The maximum length of the SET statement is 1024 bytes.
- The statement must be a Unicode string and encoded with the appropriate CCSID for the application.
- The variable is assigned the value and it is stored as specified.

Built-in global variable values persist for the lifetime of the connection unless the application explicitly sets the global variable. Built-in global variable values that are set explicitly by the application take precedence over values that are set in the profile tables. System directed connections, such as three-part name references, use the values of the global variables of the requesting Db2 site. For example, if a Java application establishes a connection to Db2 site 1, the global variable values are established with the profile tables from site 1. Later, if the application runs an SQL statement with an implicit three-part name

connection to Db2 site 2, then the global variable values that are established on site 1 are referenced when the SQL statement runs on site 2.

Commit and rollback operations have no effect on the values of global variables, regardless of how they were established.

The authorization that is required to set built-in global variables is the same that is required to insert rows into the DSN_PROFILE_TABLE and DSN_PROFILE_ATTRIBUTES tables.

Related tasks

[Monitoring and controlling Db2 by using profile tables \(Db2 Administration Guide\)](#)

Related reference

[Built-in global variables](#)

Built-in global variables are provided with the database manager and are used in SQL statements to retrieve scalar values associated with the variables.

[Profile tables \(Db2 Performance\)](#)

Built-in session variables

Db2 provides several built-in session variables that contain information about the server and application process. The value of a built-in session variable can be obtained by invoking the GETVARIABLE function with the name of the built-in session variable.

Db2 provides the following built-in session variables:

SYSIBM.APPLICATION_ENCODING_SCHEME

Contains a string that corresponds to the value that is specified for the APPLICATION ENCODING field on the DSNTIPF installation panel. The value will be EBCDIC, ASCII, UNICODE, or 1-65533, and this session variable can never be null.

SYSIBM.COBOL_STRING_DELIMITER

Contains a string that corresponds to the value that is specified for the STRING DELIMITER field on the DSNTIPF installation panel. The value will be DEFAULT, ", or ', and this session variable can never be null.

SYSIBM.DATA_SHARING_GROUP_NAME

Contains a string that corresponds to the name of the data sharing group for this Db2 subsystem. If the subsystem is not part of data sharing group, the null value is returned.

SYSIBM.DATE_FORMAT

Contains a string that corresponds to the value that is specified for the DATE FORMAT field on the DSNTIP4 installation panel. The value will be ISO, JIS, USA, EUR, or LOCAL, and this session variable can never be null.

SYSIBM.DATE_LENGTH

Contains a string that corresponds to the value that is specified for the LOCAL DATE LENGTH field on the DSNTIP4 installation panel. The value will be 10-254, or 0 for no exit, and this session variable can never be null.

SYSIBM.DECIMAL_ARITHMETIC

Contains a string that corresponds to the value that is specified for the DECIMAL ARITHMETIC field on the DSNTIP4 installation panel. The value will be DEC15, DEC31, 15, or 31, and this session variable can never be null.

SYSIBM.DECIMAL_POINT

Contains a string that corresponds to the value that is specified for the DECIMAL POINT IS field on the DSNTIPF installation panel. The value will be ' ' or ' , ' and this session variable can never be null.

SYSIBM.DEFAULT_DECFLOAT_ROUND_MODE

Contains a string that corresponds to the value that is specified for the DECFLOAT ROUNDING MODE field on the DSNTIPF installation panel. This session variable can never be null.

SYSIBM.DEFAULT_SSID

Contains a string that corresponds to the value that is specified for the GROUP ATTACH field on the DSNTIPK installation panel or the SUBSYSTEM NAME field on the DSNTIPM installation panel. This session variable can never be null.

SYSIBM.DEFAULT_LANGUAGE

Contains a string that corresponds to the value that is specified for the LANGUAGE DEFAULT field on the DSNTIPF installation panel. The value will be ASM, C, CPP, IBMCOB, FORTRAN, or PL/I, and this session variable can never be null.

SYSIBM.DEFAULT_LOCALE_LC_CTYPE

Contains a string that corresponds to the value that is specified for the LOCALE LC_CTYPE field on the DSNTIPF installation panel. This session variable can never be null.

SYSIBM.DISTRIBUTED_SQL_STRING_DELIMITER

Contains a string that corresponds to the value that is specified for the DIST SQL STR DELIMTR field on the DSNTIPF installation panel. The value will be ", or ', and this session variable can never be null.

SYSIBM.DSNHDECP_NAME

Contains a string that corresponds to the fully qualified data set name of the data set from which the DSNHDECP or a user-specified application defaults module was loaded. For instance, 'DSN910.SDSNEXIT(DSNHDECP)'. This session variable can never be null.

SYSIBM.DYNAMIC_RULES

Contains a string that corresponds to the value that is specified for the USE FOR DYNAMICRULES field on the DSNTIP4 installation panel. The value will be YES or NO, and this session variable can never be null.

SYSIBM.ENCODING_SCHEME

Contains a string that corresponds to the value that is specified for the DEF ENCODING SCHEME field on the DSNTIPF installation panel. The value will be EBCDIC, ASCII, or UNICODE, and this session variable can never be null.

SYSIBM.MIXED_DATA

Contains a string that corresponds to the value that is specified for the MIXED DATA field on the DSNTIPF installation panel. The value will be YES or NO, and this session variable can never be null.

SYSIBM.NEWFUN

Contains a string that represents the default maximum level of the SQL function syntax that is accepted by the Db2 precompiler or the Db2 coprocessor, regardless of the Db2 function level. For more information about the NEWFUN option, see [Descriptions of SQL processing options](#).

SYSIBM.PACKAGE_NAME

Contains a string that corresponds to the name of the package that is currently being executed. If a package is not currently being executed, the null value is returned. (This situation can occur when the plan that is being executed bound one or more DBRMs directly).

SYSIBM.PACKAGE_SCHEMA

Contains a string that corresponds to the collection ID of the package that is currently being executed. If a package is not currently being executed, the null value is returned.

SYSIBM.PACKAGE_VERSION

Contains a string that corresponds to the version of the package that is currently being executed. If a package is not currently being executed, the null value is returned.

SYSIBM.PAD_NUL_TERMINATED

Contains a string that corresponds to the value that is specified for the PAD NUL-TERMINATED field on the DSNTIP4 installation panel. The value will be YES or NO, and this session variable can never be null.

SYSIBM.PLAN_NAME

Contains a string that corresponds to the name to the plan that is currently being executed. This session variable can never be null.

SYSIBM.SECLABEL

Contains a string that corresponds to the RACF SECLABEL value, if any, that has been defined for the current userid. If a value has not been defined, the null value is returned.

SYSIBM.SQL_STRING_DELIMITER

Contains a string that corresponds to the value that is specified for the SQL STRING DELIMITER field on the DSNTIPF installation panel. The value will be DEFAULT, ", or ', and this session variable can never be null.

SYSIBM.SSID

Contains a string that corresponds to the actual Db2 subsystem identifier for this Db2 subsystem. This session variable can never be null.

SYSIBM.STANDARD_SQL

Contains a string that corresponds to the value that is specified for the STD SQL LANGUAGE field on the DSNTIP4 installation panel. The value will be YES or NO, and this session variable can never be null.

SYSIBM.SYSTEM_NAME

Contains a string that corresponds to the name of the Db2 for z/OS subsystem, as defined in field SUBSYSTEM NAME on installation panel DSNTIPM. This session variable can never be null.

SYSIBM.SYSTEM_ASCII_CCSID

Contains a value that represents the ASCII CCSIDs that are in use on this system. The information is returned as a comma-delimited string that corresponds to the ASCII CCSID that was specified on installation panel DSNTIPF. The three values that are returned correspond to the SBCS, MIXED, and graphic CCSID that are in use for ASCII data on this system. A value of 65534 for the MIXED or graphic CCSID indicates that this system does not support storing data in that CCSID. This session variable can never be null.

SYSIBM.SYSTEM_EBCDIC_CCSID

Contains a value that represents the EBCDIC CCSIDs that are in use on this system. The information is returned as a comma-delimited string that corresponds to the EBCDIC CCSID that was specified on installation panel DSNTIPF. The three values that are returned correspond to the SBCS, MIXED, and graphic CCSID that are in use for EBCDIC data on this system. A value of 65534 for the MIXED or graphic CCSID indicates that this system does not support storing data in that CCSID. This session variable can never be null.

SYSIBM.SYSTEM_UNICODE_CCSID

Contains a value that represents the Unicode CCSIDs that are in use on this system. The information is returned as a comma-delimited string that corresponds to the UNICODE CCSID that was specified on installation panel DSNTIPF. The three values that are returned correspond to the SBCS, MIXED, and graphic CCSID that are in use for Unicode data on this system. This session variable can never be null.

SYSIBM.TIME_FORMAT

Contains a string that corresponds to the value that is specified for the TIME FORMAT field on the DSNTIP4 installation panel. The value will be ISO, JIS, USA, EUR, or LOCAL, and this session variable can never be null.

SYSIBM.TIME_LENGTH

Contains a string that corresponds to the value that is specified for the LOCAL TIME LENGTH field on the DSNTIP4 installation panel. The value will be 8-254 or 0 for no exit, and this session variable can never be null.

SYSIBM.VERSION

Contains a string that represents the version of Db2.

The product identifier (PRDID) value is an 8-byte character value in *pppvrrm* format, where: *ppp* is a 3-letter product code; *vv* is the version; *rr* is the release; and *m* is the modification level. In Db2 12 for z/OS, the modification level indicates a range of function levels:

DSN12015 for V12R1M500 or higher.

DSN12010 for V12R1M100.

For more information, see [Product identifier \(PRDID\) values in Db2 for z/OS \(Db2 Administration Guide\)](#).

This session variable can never be null.

For example, the following statement sets the value of host variable *hv1* to the name of the plan that is currently being executed:

```
SET :hv1 = GETVARIABLE('SYSIBM.PLAN_NAME');
```

For more information about the GETVARIABLE function, see [“GETVARIABLE scalar function” on page 464](#).

Chapter 4. Built-in functions

A *function* is an operation denoted by a function name followed by zero or more input values that are enclosed in parentheses. It represents a relationship between a set of input values and a set of result values. The input values to a function are called *arguments*.

The types of functions are aggregate, scalar, and table. A built-in function is classified as an aggregate function or a scalar function. A user-defined function can be a column, scalar, or table function.

If a column mask is used to mask the column values in the final result table and a column mask is applied to a column that is an argument for a function, the result of the function might be different because the column mask is applied to the column before the function operation can take place. For example, applying a column mask to column SSN can change the result of the aggregate function, COUNT(DISTINCT SSN).

The DISTINCT operation is performed on the unmasked column values. The keyword DISTINCT is not an argument of the function but rather a specification of an operation that is performed before the function is applied. If DISTINCT is specified, redundant duplicate values are eliminated before column mask is applied. If the column in aggregate function with DISTINCT keyword has column mask definition references columns that are non-grouping column and not the target column of the DISTINCT operation, the result of aggregate function can vary. Db2 does not guarantee the same row is returned from a group of duplicates in each execution, thus, the values in those non-DISTINCT/non-grouping columns in the returned row could be different each time.

OLAP specification and functions

The RANK, DENSE_RANK, and ROW_NUMBER specifications are sometimes referred to as built-in 'functions'. Refer to [“OLAP specifications” on page 280](#) for more information on these specifications.

Db2 MQ functions

Db2 MQ functions integrate IBM MQ messaging operations within SQL statements. The functions help you integrate IBM MQ messaging with database applications. You can use the functions to access IBM MQ messaging from within SQL statements and to combine IBM MQ messaging with Db2 database access.

The functions can be scalar or table functions. For more information on using IBM MQ functions, see the information on enabling IBM MQ functions in [Additional steps for enabling IBM MQ user-defined functions \(Db2 Installation and Migration\)](#) and on programming techniques in [IBM MQ with Db2 \(Db2 Application programming and SQL\)](#).

Administrative task scheduler functions

The administrative task scheduler table functions provide information and status about the tasks that are scheduled to run using the administrative task scheduler. The administrative task scheduler provides the ability to run stored procedures, JCL jobs, and other administrative tasks according to a time or an event-based schedule. For more information, see [Scheduling administrative tasks \(Db2 Administration Guide\)](#).

List of supported built-in functions

This section contains an alphabetical list of the built-in functions that Db2 for z/OS supports.

Table 66. Supported built-in functions

Function name	Description
“ABS or ABSVAL scalar function” on page 382	Returns the absolute value of its argument
“ACOS scalar function” on page 383	Returns the arc cosine of an argument as an angle, expressed in radians

Table 66. Supported built-in functions (continued)

Function name	Description
FL 507 “ADD_DAYS scalar function” on page 383 ¹ on page 353	Returns a datetime value that represents the first argument plus a specified number of days
“ADD_MONTHS scalar function” on page 384	Returns a date that represents the date argument plus the number of months argument
“ADMIN_TASK_LIST table function” on page 669	Returns a table with one row for each of the tasks that are defined in the administrative task scheduler task list
“ADMIN_TASK_OUTPUT table function” on page 673	Returns the output parameter values and result sets, if available. If the task that was executed is not a stored procedure or the requested execution status is not available, the function returns an empty table.
“ADMIN_TASK_STATUS table function” on page 675	Returns a table with one row for each task in the administrative task scheduler task list that contains the status for the last time the task was run
“ARRAY_AGG aggregate function” on page 354	Returns an array in which each value of the input set is assigned to an element of the array
“ARRAY_DELETE scalar function” on page 386	Returns an array with the requested elements deleted.
“ARRAY_FIRST scalar function” on page 387	Returns the minimum array index value of an array.
“ARRAY_LAST scalar function” on page 388	Returns the maximum array index value of an array.
“ARRAY_NEXT scalar function” on page 389	Returns the next larger array index value for an array, relative to a specified array index argument.
“ARRAY_PRIOR scalar function” on page 391	Returns the next smaller array index value for an array, relative to a specified array index argument.
“ARRAY_TRIM scalar function” on page 392	Returns an array after removing elements from the end of an ordinary array.
“ASCII scalar function” on page 393	Returns the ASCII code value of the most character of the argument as an integer
“ASCII CHR scalar function” on page 393	Returns the character that corresponds to the ASCII code value that is specified by the argument
“ASCII_STR or ASCIISTR scalar function” on page 394	Returns an ASCII version of the character or graphic string argument
“ASIN scalar function” on page 395	Returns the arc sine of an argument as an angle, expressed in radians
“ATAN scalar function” on page 395	Returns the arc tangent of an argument as an angle, expressed in radians
“ATANH scalar function” on page 395	Returns the hyperbolic arc tangent of an argument as an angle, expressed in radians
“ATAN2 scalar function” on page 396	Returns the arc tangent of x and y coordinates as an angle, expressed in radians
“AVG aggregate function” on page 357	Returns the average of a set of numbers
“BLOB scalar function” on page 400	Returns a BLOB representation of its argument

Table 66. Supported built-in functions (continued)

Function name	Description
“BLOCKING_THREADS table function” on page 678	Returns a table with one row for each lock or claim that threads hold against the databases that are specified in the input parameter
“BIGINT scalar function” on page 396	Returns a big integer representation of its argument
“BITAND, BITANDNOT, BITOR, BITXOR, and BITNOT scalar functions” on page 398	Return a corresponding base 10 integer value in a data type that is based on the data type of the input arguments
“BINARY scalar function” on page 397	Returns a fixed-length binary string representation of its argument
FL 507 “BTRIM scalar function” on page 401 “1” on page 353	Removes the characters that are specified in a trim string from the beginning and end of a source string
“CARDINALITY scalar function” on page 402	Returns a value of that represents the number of elements of an array
“CCSID_ENCODING scalar function” on page 403	Returns the encoding scheme of a CCSID with a value of ASCII, EBCDIC, UNICODE, or UNKNOWN
“CEILING or CEIL scalar function” on page 404	Returns the smallest integer greater than or equal to the argument
“CHAR scalar function” on page 405	Returns a fixed-length character string representation of its argument
FL 506 “CHARACTER_LENGTH or CHAR_LENGTH scalar function” on page 413	Returns the length of its argument in the number of string units that are specified
“CHR scalar function” on page 415	Returns the character that corresponds to the ASCII code value that is specified by the argument
“CLOB scalar function” on page 415	Returns a CLOB representation of the first argument
“COALESCE scalar function” on page 417	Returns the first argument in a set of arguments that is not null
“COLLATION_KEY scalar function” on page 418	Returns a string that represents the collation key of the argument in the specified collation
“COMPARE_DECFLOAT scalar function” on page 421	Returns a SMALLINT value that indicates whether two arguments are equal, or unordered, or whether one argument is greater than the other
“CONCAT scalar function” on page 422	Returns the concatenation of two strings
“CONTAINS scalar function” on page 422	Returns a result about whether or not a match was found during a search of a text search index
“CORR or CORRELATION aggregate function” on page 358	Returns the coefficient of the correlation of a set of number pairs
“COS scalar function” on page 425	Returns the cosine of an argument that is expressed as an angle in radians
“COSH scalar function” on page 425	Returns the hyperbolic cosine of an argument that is expressed as an angle in radians
“COUNT aggregate function” on page 358	Returns the number of rows or values in a set of rows or values
“COUNT_BIG aggregate function” on page 359	Same as COUNT, except the result can be greater than the maximum value of an integer

Table 66. Supported built-in functions (continued)

Function name	Description
FL 506 “COVAR_POP or COVARIANCE or COVAR aggregate function” on page 360	Returns the population covariance of a set of number pairs
“COVAR_SAMP or COVARIANCE_SAMP aggregate function” on page 361	Returns unbiased sample covariance (n-1) of a set of number pairs
FL 504 CUME_DIST ^{“1”} on page 353	Returns a cumulative distribution of a row in an OLAP window
FL 504 “CUME_DIST aggregate function” on page 362 ^{“1”} on page 353	Returns the cumulative distribution of a row that is hypothetically inserted into a group of rows
“DATE scalar function” on page 425	Returns a date derived from its argument
“DAY scalar function” on page 426	Returns the day part of its argument
“DAYOFMONTH scalar function” on page 428	Similar to DAY
“DAYOFWEEK scalar function” on page 429	Returns an integer in the range 1–7, where 1 represents Sunday
“DAYOFWEEK_ISO scalar function” on page 430	Returns an integer in the range 1–7, where 1 represents Monday
“DAYOFYEAR scalar function” on page 431	Returns an integer in the range 1–366, where 1 represents January 1
“DAYS scalar function” on page 432	Returns an integer representation of a date
FL 507 “DAYS_BETWEEN scalar function” on page 433 ^{“1”} on page 353	Returns the number of full days between the specified arguments
“DBCLOB scalar function” on page 434	Returns a DBCLOB representation of its argument
“DECIMAL or DEC scalar function” on page 441	Returns a decimal representation of its argument
“DECFLOAT scalar function” on page 437	Returns a DECFLOAT representation of its argument
“DECFLOAT_FORMAT scalar function” on page 438	Returns a DECFLOAT(34) value that is based on the interpretation of the input string using the specified format
“DECFLOAT_SORTKEY scalar function” on page 440	Returns a binary value that can be used when sorting DECFLOAT values
“DECODE scalar function” on page 443	Returns a specified <i>result-expression</i> based on a comparison of input expressions (similar to the CASE expression)
“DECRYPT_BINARY, DECRYPT_BIT, DECRYPT_CHAR, and DECRYPT_DB scalar functions” on page 444	Returns the decrypted value of an encrypted argument that was encrypted using the ENCRYPT_TDES function
FL 505 “DECRYPT_DATAKEY_INTEGER, DECRYPT_DATAKEY_BIGINT, DECRYPT_DATAKEY_DECIMAL, DECRYPT_DATAKEY_VARCHAR, DECRYPT_DATAKEY_CLOB, DECRYPT_DATAKEY_VARGRAPHIC, DECRYPT_DATAKEY_DBCLOB, and DECRYPT_DATAKEY_BIT scalar functions” on page 446	Returns the decrypted value of an encrypted argument that was encrypted using the algorithm that was specified when the data was encrypted

Table 66. Supported built-in functions (continued)

Function name	Description
“DEGREES scalar function” on page 449	Returns the number of degrees for an argument that is expressed in radians
“DIFFERENCE scalar function” on page 450	Returns a value that represents the difference between the sounds of two strings based on applying the SOUNDEX function to the strings
“DIGITS scalar function” on page 450	Returns a character string representation of a number
“DOUBLE_PRECISION or DOUBLE scalar function” on page 451	Returns a double precision floating-point representation of its argument
“DSN_XMLVALIDATE scalar function” on page 452	Returns an XML value that is the result of applying XML schema validation to the first argument
“EBCDIC_CHR scalar function” on page 453	Returns the character that corresponds to the EBCDIC code value that is specified by the argument
“EBCDIC_STR scalar function” on page 453	Returns an EBCDIC version of the string argument
FL 505 “ENCRYPT_DATAKEY scalar function” on page 454	Returns the argument as an encrypted value using the specified key label and algorithm
“ENCRYPT_TDES or ENCRYPT scalar function” on page 456	Returns the argument as an encrypted value using the Triple DES encryption algorithm
“EXP scalar function” on page 458	Returns the exponential function of an argument
“EXTRACT scalar function” on page 459	Returns a portion of a date or timestamp based on its arguments
FL 504 FIRST_VALUE^{“1”} on page 353	Returns the expression value for the first row in an OLAP window
“FLOAT scalar function” on page 461	Same as DOUBLE
“FLOOR scalar function” on page 462	Returns the largest integer that is less than or equal to the argument
“GENERATE_UNIQUE and GENERATE_UNIQUE_BINARY scalar functions” on page 462	Returns a character string of bit data that is unique compared to any other execution of the function
“GETHINT scalar function” on page 463	Returns the embedded password hint from encrypted data, if one exists
“GETVARIABLE scalar function” on page 464	Returns a varying-length character string representation of the value of a session variable
“GRAPHIC scalar function” on page 465	Returns a fixed-length graphic string representation of its argument
“GREATEST scalar function” on page 470	Returns the maximum value in a set of values
“GROUPING aggregate function” on page 363	Returns a value that indicates if a row returned in a GROUP BY result is a row generated by a grouping set that excludes the column represented by its argument
FL 506 “HASH scalar function” on page 471	Returns a varying-length value that is the result of applying the specified algorithm to the first argument. It is intended for cryptographic purposes.
“HASH_CRC32, HASH_MD5, HASH_SHA1, and HASH_SHA256 scalar functions” on page 472	Return a fixed-length value that is the result of applying a hash algorithm to an input argument. They are intended for cryptographic purposes.

Table 66. Supported built-in functions (continued)

Function name	Description
FL 506 “HEX scalar function” on page 474	Returns a hexadecimal representation of its argument
“HOUR scalar function” on page 475	Returns the hour part of its argument
“IDENTITY_VAL_LOCAL scalar function” on page 476	Returns the most recently assigned value for an identity column
“IFNULL scalar function” on page 479	Returns the first argument in a set of two arguments that is not null
“INSERT scalar function” on page 480	Returns a string that is composed of an argument inserted into another argument at the same position where some number of bytes have been deleted
“INSTR scalar function” on page 482	Returns the starting position of the first occurrence of one string within another string
“INTEGER or INT scalar function” on page 483	Returns an integer representation of its argument
“JULIAN_DAY” on page 484	Returns an integer that represents the number of days from January 1, 4712 B.C.
FL 504 LAG^{“1”} on page 353	Returns the expression value for the row at offset rows before the current row
“LAST_DAY scalar function” on page 485	Returns a date that represents the last day of the month of the date argument
FL 504 LAST_VALUE^{“1”} on page 353	Returns the expression value for the last row in an OLAP window
“LCASE scalar function” on page 486	Returns a string with the characters converted to lowercase
FL 504 LEAD^{“1”} on page 353	Returns the expression value for the row at offset rows after the current row
“LEAST scalar function” on page 486	Returns the minimum value in a set of values
“LEFT scalar function” on page 487	Returns a string that consists of the specified number of most bytes or the specified string units
“LENGTH scalar function” on page 489	Returns the length of its argument
“LN scalar function” on page 490	Returns the natural logarithm of an argument
“LOCATE scalar function” on page 490	Returns the starting position of one string within another string
“LOCATE_IN_STRING scalar function” on page 493	Returns the starting position of the first occurrence of one string within another string
“LOG10 scalar function” on page 494	Returns the base 10 logarithm of an argument
“LOWER scalar function” on page 495	Returns a string with the characters converted to lowercase
“LPAD scalar function” on page 498	Returns a string that is padded on the with blanks or a specified string
“LTRIM scalar function” on page 500	Returns the characters of a string with the leading blanks or hexadecimal zeros removed
“MAX aggregate function” on page 367	Returns the maximum value in a set of column values in a group
“MAX scalar function” on page 501	Returns the maximum value in a set of values

Table 66. Supported built-in functions (continued)

Function name	Description
“MAX_CARDINALITY scalar function” on page 502	Returns a value of type BIGINT that represents the maximum number of elements that an array can contain. This value is the cardinality that was specified in the CREATE TYPE statement for an ordinary array type.
“MICROSECOND scalar function” on page 503	Returns the microsecond part of its argument
“MIDNIGHT_SECONDS scalar function” on page 504	Returns an integer in the range 0–86400 that represents the number of seconds between midnight and the argument
“MIN aggregate function” on page 369	Returns the minimum value in a set of values in a group
“MIN scalar function” on page 505	Returns the minimum value in a set of values
“MINUTE scalar function” on page 505	Returns the minute part of its argument
“MOD scalar function” on page 506	Returns the remainder of one argument divided by a second argument
“MONTH scalar function” on page 508	Returns the month part of its argument
“MONTHS_BETWEEN scalar function” on page 508	Returns an estimate of the number of months between two arguments
“MQREAD scalar function” on page 510	Returns a message from a specified IBM MQ location (return value of VARCHAR) without removing the message from the queue
“MQREADALL table function” on page 685	Returns a table containing the messages and message metadata from a specified IBM MQ location with a VARCHAR column and without removing the messages from the queue
“MQREADALLCLOB table function” on page 687	Returns a table containing the messages and message metadata from a specified IBM MQ location with a CLOB column and without removing the messages from the queue
“MQREADCLOB scalar function” on page 511	Returns a message from a specified IBM MQ location (return value of CLOB) without removing the message from the queue
“MQRECEIVE scalar function” on page 512	Returns a message from a specified IBM MQ location (return value of VARCHAR) with removal of message from the queue
“MQRECEIVEALL table function” on page 689	Returns a table containing the messages and message metadata from a specified IBM MQ location with a VARCHAR column and with removal of messages from the queue
“MQRECEIVEALLCLOB table function” on page 691	Returns a table containing the messages and message metadata from a specified IBM MQ location with a CLOB column and with removal of messages from the queue
“MQRECEIVECLOB scalar function” on page 514	Returns a message from a specified IBM MQ location (return value of CLOB) with removal of message from the queue
“MQSEND scalar function” on page 516	Sends data to a specified IBM MQ location, and returns a varying-length character string that indicates whether the function was successful or unsuccessful
“MULTIPLY_ALT scalar function” on page 517	Returns the product of the two arguments as a decimal value, used when the sum of the argument precisions exceeds 31
“NEXT_DAY scalar function” on page 518	Returns a timestamp that represents the first weekday, specified by the second argument, after the date argument

Table 66. Supported built-in functions (continued)

Function name	Description
FL 507 “NEXT_MONTH scalar function” on page 520 ^{“1” on page 353}	Returns the first day of the next month after the specified date
“NORMALIZE_DECFLOAT scalar function” on page 520	Returns a DECFLOAT value that is the result of normalizing the input argument
“NORMALIZE_STRING scalar function” on page 521	Returns a string value that is the result of normalizing the input Unicode value
FL 504 NTH_VALUE ^{“1” on page 353}	Returns the expression value for the nth-row row in an OLAP window
FL 504 NTILE ^{“1” on page 353}	Returns the quantile rank of a row
“NULLIF scalar function” on page 522	Returns NULL if the arguments are equal; else the first argument
“NVL scalar function” on page 523	Returns the first argument that is not null
“OVERLAY scalar function” on page 523	Returns a string that is composed of an argument inserted into another argument at the same position where some number of bytes have been deleted
“PACK scalar function” on page 526	Returns a binary string value that contains a data type array and a packed representation of each non-null argument
“PERCENTILE_DISC aggregate function” on page 371	Returns a percentile of a set of values
FL 504 PERCENT_RANK ^{“1” on page 353}	Returns a relative percentile rank of a row in an OLAP window
FL 504 “PERCENT_RANK aggregate function” on page 372 ^{“1” on page 353}	Returns the relative percentile rank of a row that is hypothetically inserted into a group of rows
“POSITION scalar function” on page 529	Returns the position of the first occurrence of an argument within another argument where the position is expressed in terms of the string units that are specified
“POSSTR or STRPOS scalar function” on page 532	Returns the position of the first occurrence of an argument within another argument
FL 506 “POWER or POW scalar function” on page 533	Returns the value of one argument raised to the power of a second argument
“QUANTIZE scalar function” on page 534	Returns a DECFLOAT value that is equal in value (except for any rounding) and sign to the first argument and which has an exponent set to be equal to the exponent of the second argument
“QUARTER scalar function” on page 535	Returns an integer in the range 1–4 that represents the quarter of the year for the date specified in the argument
“RADIANS scalar function” on page 536	Returns the number of radians for an argument that is expressed in degrees
“RAISE_ERROR scalar function” on page 536	Raises an error in the SQLCA with the specified SQLSTATE and error description
FL 506 “RANDOM or RAND scalar function” on page 537	Returns a double precision floating-point random number
FL 504 RATIO_TO_REPORT ^{“1” on page 353}	Returns the ratio of an argument to the sum of the arguments in an OLAP partition

Table 66. Supported built-in functions (continued)

Function name	Description
“REAL scalar function” on page 538	Returns a single precision floating-point representation of its argument
FL 504 “REGEXP_COUNT scalar function” on page 539 ^{“1” on page 353}	Returns a count of the number of times that a regular expression pattern is matched in a string
FL 504 “REGEXP_INSTR scalar function” on page 541 ^{“1” on page 353}	Returns the starting or ending position of the matched substring, depending on the value of the return_option argument
FL 504 “REGEXP_LIKE scalar function” on page 543 ^{“1” on page 353}	Returns an INTEGER value of 0 or 1 indicating if the regular expression pattern is found in a string
FL 504 “REGEXP_REPLACE scalar function” on page 546 ^{“1” on page 353}	Returns a modified version of the source string where occurrences of the regular expression pattern found in the source string are replaced with the specified replacement string
FL 504 “REGEXP_SUBSTR scalar function” on page 549 ^{“1” on page 353}	Returns one occurrence of a substring of a string that matches the regular expression pattern
FL 507 REGR_AVGX, REGR_AVGY, REGR_SXX, REGR_SXY, and REGR_SYY ^{“1” on page 353}	Return quantities that can be used to compute various diagnostic statistics needed for the evaluation of the quality and statistical validity of a regression model
FL 507 REGR_COUNT ^{“1” on page 353}	Returns the number of non-null number pairs used to fit a regression line
FL 507 REGR_INTERCEPT or REGR_ICPT ^{“1” on page 353}	Returns the y-intercept of a regression line ("b" in the equation $y = a * x + b$)
FL 507 REGR_R2 ^{“1” on page 353}	Returns the coefficient of determination ("R-squared" or "goodness-of-fit") for a regression
FL 507 REGR_SLOPE ^{“1” on page 353}	Returns the slope of a regression line ("a" in the equation $y = a * x + b$)
“REPEAT scalar function” on page 551	Returns a character string composed of an argument repeated a specified number of times
“REPLACE scalar function” on page 552	Returns a string in which all occurrences of an argument within a second argument are replaced with a third argument
“RID scalar function” on page 555	Returns the RID of a row
“RIGHT scalar function” on page 556	Returns a string that consists of the specified number of rightmost bytes or specified string units
“ROUND scalar function” on page 558	Returns a number rounded to the specified number of places to the right or of the decimal place
“ROUND_TIMESTAMP scalar function” on page 559	Returns a timestamp rounded to the unit specified by the timestamp format string
“ROWID scalar function” on page 563	Returns a row ID representation of its argument
“RPAD scalar function” on page 563	Returns a string that is padded on the right with blanks or a specified string
“RTRIM scalar function” on page 565	Returns the characters of an argument with the trailing blanks or hexadecimal zeros removed
“SCORE scalar function” on page 566	Returns a relevance score that measures how well a document matches the query used to search a text search index

Table 66. Supported built-in functions (continued)

Function name	Description
“SECOND scalar function” on page 568	Returns the second part of its argument
“SIGN scalar function” on page 570	Returns the sign of an argument
“SIN scalar function” on page 570	Returns the sine of an argument that is expressed as an angle in radians
“SINH scalar function” on page 571	Returns the hyperbolic sine of an argument that is expressed as an angle in radians
“SMALLINT scalar function” on page 571	Returns a small integer representation of its argument
“SOAPHTTTPC and SOAPHTTTPV scalar function” on page 573	Returns a CLOB or VARCHAR representation of XML data from a request to a web service
“SOAPHTTTPNC and SOAPHTTTPNV scalar function” on page 574	Returns a complete CLOB or VARCHAR representation of XML data from a complete request to a web service
“SOUNDEX scalar function” on page 572	Returns a value that represents the sound of the words in the argument
“SPACE scalar function” on page 575	Returns a string that consists of the number of blanks the argument specifies
“SQRT scalar function” on page 575	Returns the square root of its argument
“STDDEV_POP or STDDEV aggregate function” on page 376	Returns the population standard deviation (division by n) of a set of numbers
“STDDEV_SAMP aggregate function” on page 377	Returns the sample standard deviation (division by $n-1$) of a set of numbers
“STRIP scalar function” on page 576	Returns the characters of a string with the blanks (or specified character) at the beginning, end, or both beginning and end of the string removed
FL 506 “STRLEFT scalar function” on page 576	Returns a string that consists of the specified number of most bytes or the specified string units
FL 506 “STRPOS scalar function” on page 577	Returns the position of the first occurrence of an argument within another argument
FL 506 “STRRIGHT scalar function” on page 577	Returns a string that consists of the specified number of rightmost bytes or specified string units
“SUBSTR scalar function” on page 577	Returns a substring of a string
“SUBSTRING scalar function” on page 579	Returns a substring of a string using the specified string units
“SUM aggregate function” on page 378	Returns the sum of a set of numbers
“TAN scalar function” on page 583	Returns the tangent of an argument that is expressed as an angle in radians
“TANH scalar function” on page 583	Returns the hyperbolic tangent of an argument that is expressed as an angle in radians
“TIME scalar function” on page 584	Returns a time derived from its argument
“TIMESTAMP scalar function” on page 584	Returns a timestamp derived from its arguments
“TIMESTAMPADD scalar function” on page 587	Returns a timestamp derived from adding the specified interval to a timestamp

Table 66. Supported built-in functions (continued)

Function name	Description
“TIMESTAMP_FORMAT or TO_TIMESTAMP scalar function” on page 591	Returns a timestamp for a character string expression, using a specified format to interpret the string
“TIMESTAMP_ISO scalar function” on page 595	Returns a timestamp derived from its arguments
“TIMESTAMPDIFF scalar function” on page 588	Returns an estimated number of the specified intervals based on the difference between two timestamps
“TIMESTAMP_TZ scalar function” on page 596	Returns a timestamp with a time zone derived from its arguments
“TO_CHAR scalar function” on page 598	Returns a character string representation of a timestamp value that has been formatted using a specified character template
FL 506 “TO_CLOB scalar function” on page 598	Returns a CLOB representation of the first argument
“TO_DATE scalar function” on page 599	Returns a timestamp value that is based on the interpretation of the input string using the specified format
“TO_NUMBER scalar function” on page 599	Returns a DECFLOAT(34) value that is based on the interpretation of the input string using the specified format
“TOTALORDER scalar function” on page 599	Returns a SMALLINT value that indicates the comparison order of two arguments
FL 506 “TO_TIMESTAMP scalar function” on page 600	Returns a timestamp for a character string expression, using a specified format to interpret the string
“TRANSLATE scalar function” on page 600	Returns a string with one or more characters translated
“TRIM scalar function” on page 603	Removes bytes from the beginning, from the end, or from both the beginning and end of a string expression
“TRIM_ARRAY scalar function” on page 605	Returns an array after removing elements from the end of an ordinary array.
“TRUNCATE or TRUNC scalar function” on page 606	Returns a number truncated to the specified number of places to the right or of the decimal point
“TRUNC_TIMESTAMP scalar function” on page 607	Returns a timestamp truncated to the unit specified by the timestamp format string
“UCASE scalar function” on page 610	Returns a string with the characters converted to uppercase
“UNICODE scalar function” on page 610	Returns the Unicode (UTF-16) code value of the most character of the argument as an integer
“UNICODE_STR or UNISTR scalar function” on page 611	Returns a string in Unicode (UTF-8 or UTF-16) that represents a Unicode encoding of the argument
“UNPACK row function” on page 696	Returns a row of values that are derived from unpacking the input binary string. It is used to unpack a string that was encoded according to the PACK function
“UPPER scalar function” on page 612	Returns a string with the characters converted to uppercase
“VALUE scalar function” on page 614	Same as COALESCE
“VARBINARY scalar function” on page 614	Returns a varying-length binary string representation of its argument

Table 66. Supported built-in functions (continued)

Function name	Description
“VARCHAR scalar function” on page 615	Returns the varying-length character string representation of its argument
“VARCHAR9 scalar function” on page 620	Returns the fixed-length character string representation of its argument
“VARCHAR_FORMAT scalar function” on page 623	Returns a varying-length character string representation of a timestamp, with the string in a specified format
“VARGRAPHIC scalar function” on page 632	Returns a varying-length graphic string representation of its argument
“VAR_POP or VARIANCE or VAR aggregate function” on page 379	Returns the biased variance (division by n) of a set of numbers
“VAR_SAMP or VARIANCE_SAMP aggregate function” on page 380	Returns the sample variance (division by $n-1$) of a set of numbers
“VERIFY_GROUP_FOR_USER scalar function” on page 637	Returns a value that indicates whether the primary authorization ID and the group authorization IDs that are associated with the first argument are included in the authorization names that are specified in the list of the second argument.
“VERIFY_ROLE_FOR_USER scalar function” on page 638	Returns a value that indicates whether the roles that are associated with the first argument are included in the role names that are specified in the list of the second argument
“VERIFY_TRUSTED_CONTEXT_ROLE_FOR_USER scalar function” on page 640	Returns a value that indicates whether the authorization ID that is associated with first argument has acquired a role in a trusted connection and whether that acquired role is included in the role names that are specified in the list of the second argument
“WEEK scalar function” on page 641	Returns an integer that represents the week of the year with Sunday as the first day of the week
“WEEK_ISO scalar function” on page 642	Returns an integer that represents the week of the year with Monday as first day of a week
“XMLAGG aggregate function” on page 381	Returns an XML type that represents a concatenation of XML elements from a collection of XML elements
“XMLATTRIBUTES scalar function” on page 644	Returns an XML sequence that contains an XQuery attribute node for each non-null argument
“XMLCOMMENT scalar function” on page 645	Returns an XML value with a single comment node from a string expression
“XMLCONCAT scalar function” on page 645	Returns an XML value that represents a forest of XML elements generated by concatenating a variable number of arguments
“XMLDOCUMENT scalar function” on page 646	Returns an XML value with a single document node and zero or more nodes as its children
“XMLELEMENT scalar function” on page 647	Returns an XML value that represents an XML element
“XMLFOREST scalar function” on page 651	Returns an XML value that represents a forest of XML elements that all share a specific pattern

Table 66. Supported built-in functions (continued)

Function name	Description
“XMLMODIFY scalar function” on page 653	Returns an XML value that might have been modified by the evaluation of an XQuery updating expression and XQuery variables that are specified as input arguments
“XMLNAMESPACES scalar function” on page 656	Returns the declaration of one or more XML namespaces
“XMLPARSE scalar function” on page 657	Returns an XML value from parsing the argument as an XML document
“XMLPI scalar function” on page 659	Returns an XML value with a single processing instruction node
“XMLQUERY scalar function” on page 659	Returns an XML value from the evaluation of an XPath expression against a set of arguments
“XMLSERIALIZE scalar function” on page 662	Returns an SQL character string or a BLOB value from an XML value
“XMLTABLE table function” on page 693	Returns a result table from the evaluation of XQuery expressions, possibly using specified input arguments as XQuery variables
“XMLTEXT scalar function” on page 665	Returns an XML value with a single text node that contains the value of the argument
“XMLXSROBJECTID scalar function” on page 666	Returns the XSR object identifier of the XML schema that is used to validate the XML document specified in the argument
“XSLTRANSFORM scalar function” on page 667	The XSLTRANSFORM function transforms an XML document into a different data format. The output can be any form possible for the XSLT processor, including but not limited to XML, HTML, and plain text. Note: This is a Db2-supplied user-defined function.
“YEAR scalar function” on page 668	Returns the year part of its argument

Notes:

1. Supported in Db2 for z/OS as a passthrough-only expression, which is passed through to IBM Db2 Analytics Accelerator for z/OS. For more information, see [Accelerating queries with passthrough-only expressions](#).

Aggregate functions

An aggregate function, which is also known as a *set function*, receives a set of values for each argument (such as the values of a column) and returns a single-value result for the set of input values. Certain rules apply to all aggregate functions.

The following information applies to all aggregate functions, except for the COUNT(*) and COUNT_BIG(*), variations of the COUNT and COUNT_BIG functions, and the XMLAGG function.

The argument of an aggregate function is a set of values derived from an expression. The expression must not include another aggregate function or a scalar fullselect. The scope of the set is a group or an intermediate result table, as explained in the information on the GROUP BY clause.

If a GROUP BY clause is specified in a query and the intermediate result from the FROM, WHERE, GROUP BY, and HAVING clauses is the empty set, then the aggregate functions are not applied and the result of the query is the empty set.

If the GROUP BY clause is not specified in a query and the intermediate result table of the FROM, WHERE, and HAVING clauses is the empty set, then the aggregate functions are applied to the empty set.

For example, the result of the following SELECT statement is the number of distinct values of JOB for employees in department D11:

```
SELECT COUNT(DISTINCT JOB)
FROM DSN8C10.EMP
WHERE WORKDEPT = 'D11';
```

The keyword DISTINCT is not an argument of the function but rather a specification of an operation that is performed before the function is applied. If DISTINCT is specified, redundant duplicate values are eliminated before column mask is applied. If the column in aggregate function with DISTINCT keyword has column mask definition references columns that are non-grouping column and not the target column of the DISTINCT operation, the result of aggregate function can vary. Db2 does not guarantee the same row is returned from a group of duplicates in each execution, thus, the values in those non-DISTINCT/non-grouping columns in the returned row could be different each time.

DISTINCT must not be specified preceding an XML value.

For compatibility with other SQL implementations, UNIQUE can be specified as a synonym for DISTINCT in aggregate functions.

When interpreting the DISTINCT clause for decimal floating-point values that are numerically equal, the number of significant digits in the value is not considered. For example, the decimal floating-point number 123.00 is not distinct from the decimal floating-point number 123. The representation of the number returned from the query will be any one of the representations encountered (for example, either 123.00 or 123).

An aggregate function can be used in a WHERE clause only if that clause is part of a subquery of a HAVING clause and the column name specified in the expression is a correlated reference to a group. If the expression includes more than one column name, each column name must be a correlated reference to the same group.

The result of the COUNT and COUNT_BIG functions cannot be the null value. As specified in the description of AVG, MAX, MIN, STDDEV, SUM, and VARIANCE, the result is the null value when the function is applied to an empty set. However, the result is also the null value when the function is specified in an outer select list, the argument is given by an arithmetic expression, and any evaluation of the expression causes an arithmetic exception (such as division by zero).

If the argument values of an aggregate function are strings from a column with a field procedure, the function is applied to the encoded form of the values and the result of the function inherits the field procedure.

Related reference

[group-by-clause](#)

The GROUP BY clause specifies a result table that consists of a grouping of the rows of intermediate result table that is the result of the previous clause.

ARRAY_AGG aggregate function

The ARRAY_AGG function returns an array in which each value of the input set is assigned to an element of the array.

Syntax for ordinary array aggregation

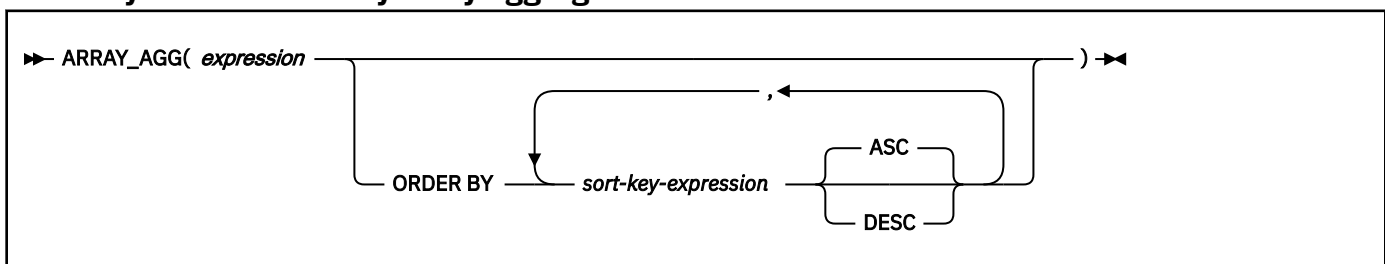

Syntax for associative array aggregation

```
► ARRAY_AGG( index-expression , expression ) ◄
```

The schema is SYSIBM.

Ordinary array aggregation

expression

Specifies an expression that returns a value with a data type that is valid for an array element. The data type of the expression must be a data type that can be specified in a CREATE TYPE (array) statement.

expression must not contain a scalar fullselect.

ORDER BY

Specifies the order of the rows from the same grouping set that are processed in the aggregation. If the ORDER BY clause is not specified, or if the ORDER BY clause cannot differentiate the order of the sort key value, the rows in the same grouping set are arbitrarily ordered.

If a SELECT clause includes multiple invocations of the ARRAY_AGG function, all invocations of ARRAY_AGG in the same SELECT clause that explicitly specify an ORDER BY clause must specify the same order, or not specify an order.

sort-key-expression

Specifies a sort key value that is either a column name or an expression. *sort-key-expression* must not reference a column for which a column mask is defined.

If the sort key value is a constant, the constant does not refer to the position of the output column, but is simply a constant, which implies that there is no sort key.

ASC

Processes the sort key in ascending order. This is the default option.

DESC

Processes the sort key in descending order.

Associative array aggregation

index-expression

Specifies an expression for the index of the associative array.

When the ARRAY_AGG function is invoked in a context in which there is a target user-defined array data type in the same statement, or the result of the ARRAY_AGG function is explicitly cast to a user-defined array data type, the data type of *index-expression* must be castable to the index data type of the target associative array data type. Otherwise, the expression must return a value with a data type that is valid for an array element. The data type of the expression must be a data type that can be specified in a CREATE TYPE (Array) statement.

Duplicate *index-expression* values must not exist in the grouping set that is used to produce the associative array.

expression

Specifies an expression that returns a value with a data type that is valid for an array element. The data type of the expression must be a data type that can be specified in a CREATE TYPE (array) statement.

The result data type of ARRAY_AGG is an array. The data type of an array element of the result array is the same as the type of *expression*.

The ARRAY_AGG function can be invoked only in the following contexts:

- The SELECT list of a SELECT INTO statement

- The SELECT list of the outermost fullselect in the definition of a cursor that is not scrollable, in an SQL PL context
- The SELECT list of a scalar subquery that provides a source value for a SET *assignment-statement* or SQL PL *assignment-statement*
- A RETURN statement in an SQL scalar function

The following restrictions apply to ARRAY_AGG:

- ARRAY_AGG cannot be used as part of an OLAP specification.
- A fullselect that contains an invocation of ARRAY_AGG cannot contain an ORDER BY clause.
- A fullselect that contains an invocation of ARRAY_AGG cannot contain a DISTINCT keyword in its SELECT list.
- The SELECT clause or HAVING clause of the fullselect that contains an invocation of ARRAY_AGG cannot contain a subquery.
- A SELECT clause that includes an invocation of the ARRAY_AGG function that returns an array of LOBs must not also include a GROUP BY clause.
- A SELECT clause that includes an invocation of the ARRAY_AGG function must not also include an invocation of the LISTAGG function or the XMLAGG function.

Examples for ARRAY_AGG

- Use ARRAY_AGG in an assignment statement to assign the values of the DECIMALARRAY ordinary array to the array INTARRAY.

```
SET INTARRAY = (SELECT ARRAY_AGG(VAL) FROM UNNEST(DECIMALARRAY) AS T(VAL));
```

- Use ARRAY_AGG in a SELECT INTO statement to assign the values of the ESALARIES ordinary array to the array ARRAY2.

```
SELECT ARRAY_AGG(T.VAL) INTO ARRAY2 FROM UNNEST(ESALARIES) AS T(VAL);
```

- Use ARRAY_AGG to aggregate a set of phone numbers into an ordinary array. The array elements are then assigned to ordinary array NUMBERS in order by priority, or in arbitrary order. Suppose that user-defined type PHONELIST and table EMPLOYEE have the following definitions:

```
CREATE TYPE PHONELIST AS DECIMAL(10,0) ARRAY[10];

CREATE TABLE EMPLOYEE ( ID INTEGER NOT NULL,
  PRIORITY INTEGER NOT NULL,
  PHONENUMBER DECIMAL(10,0),
  PRIMARY KEY(ID, PRIORITY)) ;
```

The following SQL PL procedure uses a SELECT INTO statement that returns a list of contact numbers under which an employee can be reached, ordered by priority.

```
CREATE PROCEDURE GETPHONENUMBERS
  (IN EMPID INTEGER,
  OUT NUMBERS PHONELIST)
BEGIN
  SELECT ARRAY_AGG(PHONENUMBER ORDER BY PRIORITY)
  INTO NUMBERS
  FROM EMPLOYEE
  WHERE ID = EMPID;
END
```

The following SQL PL procedure uses SET *assignment-statement* to return the list of contact numbers in an arbitrary order.

```
CREATE PROCEDURE GETPHONENUMBERS
  (IN EMPID INTEGER,
  OUT NUMBERS PHONELIST)
BEGIN
  SET NUMBERS =
```



```
(SELECT ARRAY_AGG(PHONENUMBER)
FROM EMPLOYEE
WHERE ID = EMPID);
END
```

- Use ARRAY_AGG to aggregate a set of phone numbers into an associative array. The array elements are then assigned to associative array EMPLOYEES.

Suppose that user-defined type EMPPHONES and table EMPLOYEE have the following definitions:

```
CREATE TYPE EMPPHONES AS DECIMAL(10,0) ARRAY[INTEGER];

CREATE TABLE EMPLOYEE ( ID INTEGER NOT NULL,
PRIORITY INTEGER NOT NULL,
PHONENUMBER DECIMAL(10,0),
PRIMARY KEY(ID, PRIORITY)) ;
```

Create a procedure that uses a SELECT INTO statement to aggregate priority 1 phone numbers into an associative array that is indexed by IDs from the EMPLOYEE table.

```
CREATE PROCEDURE GETPHONES
(OUT EMPLOYEES EMPPHONES)
BEGIN
SELECT ARRAY_AGG(ID, PHONENUMBER)
INTO EMPLOYEES
FROM EMPLOYEE WHERE PRIORITY=1;
END
```

AVG aggregate function

The AVG function returns the average of a set of numbers.

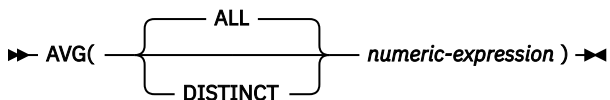

The schema is SYSIBM.

The argument values can be of any built-in numeric data type, and their sum must be within the range of the data type of the result.

The arguments can also be a character string or graphic string data type. The string input is implicitly cast to a numeric value of DECFLOAT(34).

The data type of the result is determined as follows:

- DECFLOAT(34) if the argument is DECFLOAT(*n*).
- Large integer if the argument is small integer.
- Double precision floating-point if the argument is single precision floating-point.
- Otherwise, the result is the same as the data type of the argument.

The result can be null.

If the data type of the argument values is decimal with precision *p* and scale *s*, the precision (P) and scale (S) of the result depend on *p* and the decimal precision option:

- If *p* is greater than 15 or the DEC31 option is in effect, P is 31 and S is $\max(0, 28 - p + s)$.
- Otherwise, P is 15 and S is $15 - p + s$.

The function is applied to the set of values derived from the argument values by the elimination of null values. If DISTINCT is specified, redundant duplicate values are also eliminated.

If the function is applied to an empty set, the result is the null value. Otherwise, the result is the average value of the set. The order in which the summation part of the operation is performed is undefined but every intermediate result must be within the range of the result data type.

If the type of the result is integer, the fractional part of the average is lost.

Example: Assuming DEC15, set the DECIMAL(15,2) variable AVERAGE to the average salary in department D11 of the employees in the sample table DSN8C10.EMP.

```
EXEC SQL SELECT AVG(SALARY)
INTO :AVERAGE
FROM DSN8C10.EMP
WHERE WORKDEPT = 'D11';
```

CORR or CORRELATION aggregate function

The CORR function returns the coefficient of the correlation of a set of number pairs.

The schema is SYSIBM.

The argument values must each be the value of any built-in numeric data type.

If an argument is DECFLOAT(*n*), the result of the function is DECFLOAT(34). Otherwise, the result of the function is double precision floating-point. The result is between -1 and 1. The result can be null.

The function is applied to the set of (*expression-1*, *expression-2*) pairs derived from the argument values by the elimination of all pairs for which either *expression-1* or *expression-2* is null.

If the function is applied to an empty set, or if either STDDEV(*expression-1*) or STDDEV(*expression-2*) is equal to zero, the result is a null value. Otherwise, the result is the correlation coefficient for the value pairs in the set. The result is equivalent to the following expression:

$$\frac{\text{COVARIANCE}(\textit{expression-1}, \textit{expression-2})}{(\text{STDDEV}(\textit{expression-1}) * \text{STDDEV}(\textit{expression-2}))}$$

The order in which the values are aggregated is undefined, but every intermediate result must be within the range of the result data type.

Using sample table DSN8C10.EMP, set the host variable :corrln (double-precision floating point) to the correlation between the salary and the bonus for those employees in department (WORKDEPT) 'A00'.

```
SELECT CORRELATION(SALARY, BONUS) INTO :corrln
FROM DSN8C10.EMP WHERE WORKDEPT = 'A00';
```

:corrln is set to approximately 9.99853953399538E-001.

COUNT aggregate function

The COUNT function returns the number of rows or values in a set of rows or values.

The schema is SYSIBM.

The argument values can be of any built-in data type other than a BLOB, CLOB, DBCLOB, or XML.

The result is a large integer. The result cannot be null.

The argument of COUNT(*) is a set of rows. The result is the number of rows in the set. Any row that includes only null values is included in the count.

The argument of COUNT(*expression*) or COUNT(ALL *expression*) is a set of values. The function is applied to the set of values derived from the argument values by the elimination of null values. The result is the number of nonnull values in the set, including duplicates.

The argument of COUNT(DISTINCT *expression*) is a set of values. The function is applied to the set of values derived from the argument values by the elimination of null values and redundant duplicate values. The result is the number of different nonnull values in the set.

Example 1: Set the integer host variable FEMALE to the number of females represented in the sample table DSN8C10.EMP.

```
EXEC SQL SELECT COUNT(*)
  INTO :FEMALE
  FROM DSN8C10.EMP
  WHERE SEX = 'F';
```

Example 2: Set the integer host variable FEMALE_IN_DEPT to the number of departments that have at least one female as a member.

```
EXEC SQL SELECT COUNT(DISTINCT WORKDEPT)
  INTO :FEMALE_IN_DEPT
  FROM DSN8C10.EMP
  WHERE SEX = 'F';
```

COUNT_BIG aggregate function

The COUNT_BIG function returns the number of rows or values in a set of rows or values. It is similar to COUNT except that the result can be greater than the maximum value of an integer.

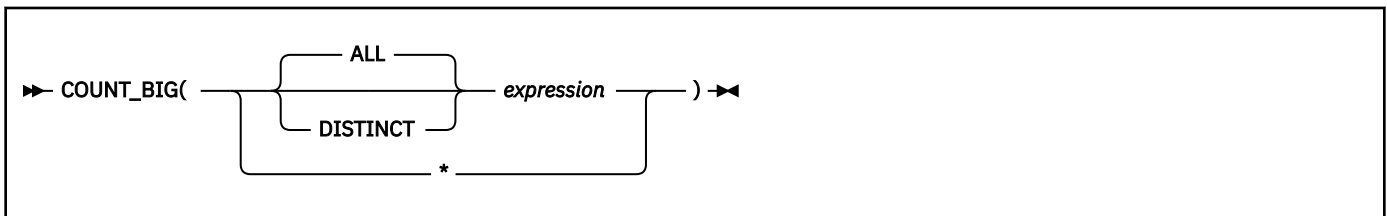

The schema is SYSIBM.

The argument values can be of any built-in data type other than a BLOB, CLOB, DBCLOB, or XML.

The result of the function is a decimal number with precision 31 and scale 0. The result cannot be null.

The argument of COUNT_BIG(*) is a set of rows. The result is the number of rows in the set. A row that includes only null values is included in the count.

The argument of COUNT_BIG(*expression*) or COUNT_BIG(ALL *expression*) is a set of values. The function is applied to the set of values derived from the argument values by the elimination of null values. The result is the number of nonnull values in the set, including duplicates.

The argument of COUNT_BIG(DISTINCT *expression*) is a set of values. The function is applied to the set of values derived from the argument values by the elimination of null and redundant duplicate values. The result is the number of different nonnull values in the set.

Example 1: Set the integer host variable FEMALE to the number of females represented in the sample table DSN8C10.EMP.

```
EXEC SQL SELECT COUNT_BIG(*)
  INTO :FEMALE
  FROM DSN8C10.EMP
  WHERE SEX = 'F';
```

Example 2: Set the integer host variable FEMALE_IN_DEPT to the number of departments that have at least one female as a member.

```
EXEC SQL SELECT COUNT_BIG(DISTINCT WORKDEPT)
          INTO :FEMALE_IN_DEPT
          FROM DSN8C10.EMP
          WHERE SEX = 'F';
```

Example 3: To create a sourced function that is similar to the built-in COUNT_BIG function, the definition of the sourced function must include the type of the column that can be specified when the new function is invoked. In this example, the CREATE FUNCTION statement creates a sourced function that takes a CHAR column as input and uses COUNT_BIG to perform the counting. The result is returned as a double precision floating-point number. The query shown counts the number of unique departments in the sample employee table.

```
CREATE FUNCTION RICK.COUNT(CHAR()) RETURNS DOUBLE
SOURCE SYSIBM.COUNT_BIG(CHAR());
SET CURRENT PATH RICK, SYSTEM PATH;
SELECT COUNT(DISTINCT WORKDEPT) FROM DSN8C10.EMP;
```

The empty parenthesis in the parameter list for the new function (RICK.COUNT) means that the input parameter for the new function is the same type as the input parameter for the function named in the SOURCE clause. The empty parenthesis in the parameter list in the SOURCE clause (SYSIBM.COUNT_BIG) means that the length attribute of the CHAR parameter of the COUNT_BIG function is ignored when Db2 locates the COUNT_BIG function.

COVAR_POP or COVARIANCE or COVAR aggregate function

The COVAR_POP function returns the population covariance of a set of number pairs.

[FL 506](#)

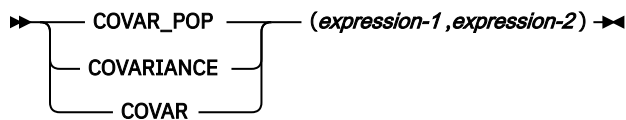

The schema is SYSIBM.

The argument values must each be the value of any built-in numeric data type.

If an argument is DECFLOAT(*n*), the result of the function is DECFLOAT(34). Otherwise, the result of the function is double precision floating-point. The result can be null.

The function is applied to the set of (*expression-1*, *expression-2*) pairs that are derived from the argument values by the elimination of all pairs for which either *expression-1* or *expression-2* is null.

If the function is applied to an empty set, the result is a null value. Otherwise, the result is the population covariance of the value pairs in the set. The result is equivalent to the following output:

1. Let *avgexp1* be the result of AVG(*expression-1*) and let *avgexp2* be the result of AVG(*expression-2*).
2. The result of COVARIANCE(*expression-1*, *expression-2*) is AVG((*expression-1* - *avgexp1*) * (*expression-2* - *avgexp2*))

The order in which the values are aggregated is undefined, but every intermediate result must be within the range of the result data type.

Example

Using sample table DSN8C10.EMP, set the host variable COVARNCE (double-precision floating-point) to the population covariance between the salary and the bonus for those employees in department (WORKDEPT) 'A00'.

```
SELECT COVARIANCE(SALARY, BONUS)
       INTO :covaince
       FROM DSN8C10.EMP
       WHERE WORKDEPT = 'A00'
```

The value of COVARNCE is set to 1743000.

Notes

Syntax alternatives:

COVAR_POP should be used for conformance to the SQL standard.

COVAR_SAMP or COVARIANCE_SAMP aggregate function

The COVAR_SAMP function returns unbiased sample covariance ($n-1$) of a set of number pairs.

Diagram illustrating the function signature: $\text{COVAR_SAMP}(\text{expression-1}, \text{expression-2})$. A bracket below the function name indicates that COVARIANCE_SAMP is an alternative name for the same function.

The schema is SYSIBM.

The argument values must each be the value of any built-in numeric data type.

If an argument is $\text{DECFLOAT}(n)$, the result of the function is $\text{DECFLOAT}(34)$. Otherwise, the result of the function is double precision floating-point. The result can be null.

The function is applied to the set of $(\text{expression-1}, \text{expression-2})$ pairs that are derived from the argument values by the elimination of all pairs for which either expression-1 or expression-2 is null.

If the function is applied to an empty set, the result is a null value. Otherwise, the result is the sample covariance of the value pairs in the set. The result is equivalent to the following output:

1. Let samp_avgexp1 be the result of $\text{SUM}(\text{expression-1})/n-1$ and let samp_avgexp2 be the result of $\text{SUM}(\text{expression-2})/n-1$.
2. The result of $\text{COVAR_SAMP}(\text{expression-1}, \text{expression-2})$ is $\text{AVG}((\text{expression-1} - \text{samp_avgexp1}) * (\text{expression-2} - \text{samp_avgexp2}))$

The order in which the values are aggregated is undefined, but every intermediate result must be within the range of the result data type.

The following restrictions apply to COVAR_SAMP:

- COVAR_SAMP cannot be used as part of an OLAP specification.

Notes

Syntax alternatives:

COVAR_SAMP should be used for conformance to the SQL standard.

Example

Using sample table DSN8C10.EMP, set the host variable COVARNCE (double-precision floating point) to the sample covariance between the salary and the bonus for those employees in department (WORKDEPT) 'A00'.

```
SELECT COVAR_SAMP(SALARY, BONUS)
INTO :COVARNCE
FROM DSN8C10.EMP
WHERE WORKDEPT = 'A00';
```

The value of COVARNCE is set to 2178750.

CUME_DIST aggregate function

The CUME_DIST function returns the cumulative distribution of a row that is hypothetically inserted into a group of rows.

FL 504

Passthrough-only expression: This function is passthrough-only and cannot run on Db2 for z/OS without acceleration. For information about invoking this function, see [Accelerating queries with passthrough-only expressions](#).

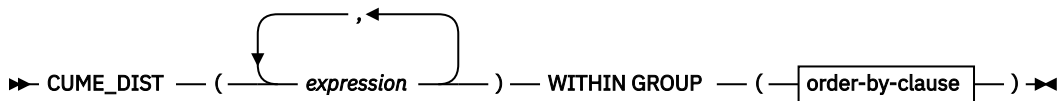

order-by-clause

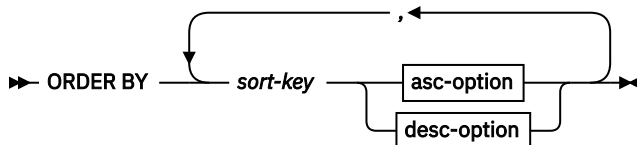

asc-option

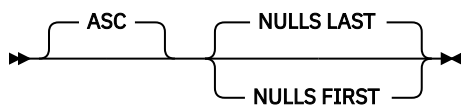

desc-option

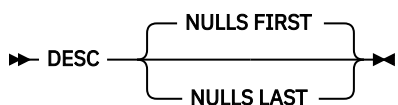

The schema is SYSIBM.

expression

An expression that specifies a row that is hypothetically inserted into a group of rows. The expression must return a value that is a built-in data type. The expression must be a constant, a variable, or a cast of a constant or variable.

WITHIN GROUP

Indicates that the aggregation follows the specified ordering within the grouping set.

order-by-clause

ORDER BY

Specifies the order of the rows from the same grouping set that are processed in the aggregation.

sort-key

The sort key can be a column name or a sort-key-expression. If the sort key is a constant, it does not refer to the position of the output column (as in the ordinary ORDER BY clause), but it is a constant, which implies no sort key.

ASC

Uses the values of the *sort-key* in ascending order.

DESC

Uses the values of the *sort-key* in descending order.

NULLS FIRST

The ordering considers null values before all non-null values in the sort order.

NULLS LAST

The ordering considers null values after all non-null values in the sort order.

The number of expressions must be the same as the number of sort-key expressions. The data type of each expression and the data type of the corresponding sort-key expression must be compatible.

The data type of the result is DECFLOAT(34). The actual result is greater than 0.0 and less than or equal to 1.0.

Example

Set the host variable CD to the cumulative distribution of a hypothetical new employee's salary of 47000 within the salaries of the employees in department 'A00'.

```
SELECT CUME_DIST(47000) WITHIN GROUP (ORDER BY SALARY)
INTO :CD FROM EMPLOYEE WHERE WORKDEPT = 'A00'
```

Related concepts

[How Db2 determines whether to accelerate eligible queries \(Db2 Performance\)](#)

GROUPING aggregate function

When used in conjunction with *grouping-sets* and *super-groups*, the GROUPING function returns a value that indicates if a row returned in a GROUP BY result is a row generated by a grouping set that excludes the column represented by *expression*.

```
►► GROUPING( expression ) ◄◄
```

The schema is SYSIBM.

expression

An expression that matches a *grouping-expression* from the GROUP BY clause of the same subselect.

The result of the function is a small integer value. The result is one of the following values:

1

The value of *expression* in the returned row is a null value, and the row was generated by the *super-group*. This generated row can be used to provide *sub-total* values for the GROUP BY expression.

0

The value is other than the previously listed value.

Example

```
SELECT SALES_DATE, SALES_PERSON,
       SUM(SALES) AS UNITS_SOLD,
       GROUPING(SALES_DATE) AS DATE_GROUP,
       GROUPING(SALES_PERSON) AS SALES_GROUP
FROM SALES
```

```
GROUP BY CUBE (SALES_DATE, SALES_PERSON)
ORDER BY SALES_DATE, SALES_PERSON;
```

The previous query returns results similar to the following:

SALES_DATE	SALES_PERSON	UNITS_SOLD	DATE_GROUP	SALES_GROUP
12/31/1995	GOUNOT	1	0	0
12/31/1995	LEE	6	0	0
12/31/1995	LUCCHESSEI	1	0	0
12/31/1995	-	8	0	1
03/29/1996	GOUNOT	11	0	0
03/29/1996	LEE	12	0	0
03/29/1996	LUCCHESSEI	4	0	0
03/29/1996	-	27	0	1
03/30/1996	GOUNOT	21	0	0
03/30/1996	LEE	21	0	0
03/30/1996	LUCCHESSEI	4	0	0
03/30/1996	-	46	0	1
03/31/1996	GOUNOT	3	0	0
03/31/1996	LEE	27	0	0
03/31/1996	LUCCHESSEI	1	0	0
03/31/1996	-	31	0	1
04/01/1996	GOUNOT	14	0	0
04/01/1996	LEE	25	0	0
04/01/1996	LUCCHESSEI	4	0	0
04/01/1996	-	43	0	1
-	GOUNOT	50	1	0
-	LEE	91	1	0
-	LUCCHESSEI	14	1	0
-	-	155	1	1

An application can identify a SALES_DATE *sub-total* row because the value of DATE_GROUP is 0 and the value of SALES_GROUP is 1. A SALES_PERSON *sub-total* row can be identified because the value of DATE_GROUP is 1 and the value of SALES_GROUP is 0. A *grand total* row can be identified by the value 1 for both DATE_GROUP and SALES_GROUP.

Related reference

[group-by-clause](#)

The GROUP BY clause specifies a result table that consists of a grouping of the rows of intermediate result table that is the result of the previous clause.

[Examples of grouping sets, rollup, and cube queries](#)

You can use GROUPING SETS, ROLLUP, and CUBE clauses of the GROUP BY clause in subselect queries.

LISTAGG aggregate function

The LISTAGG function aggregates a set of strings into one string by concatenating the strings. Optionally, a separator string can be provided which is inserted between contiguous input strings.

[FL 501](#)

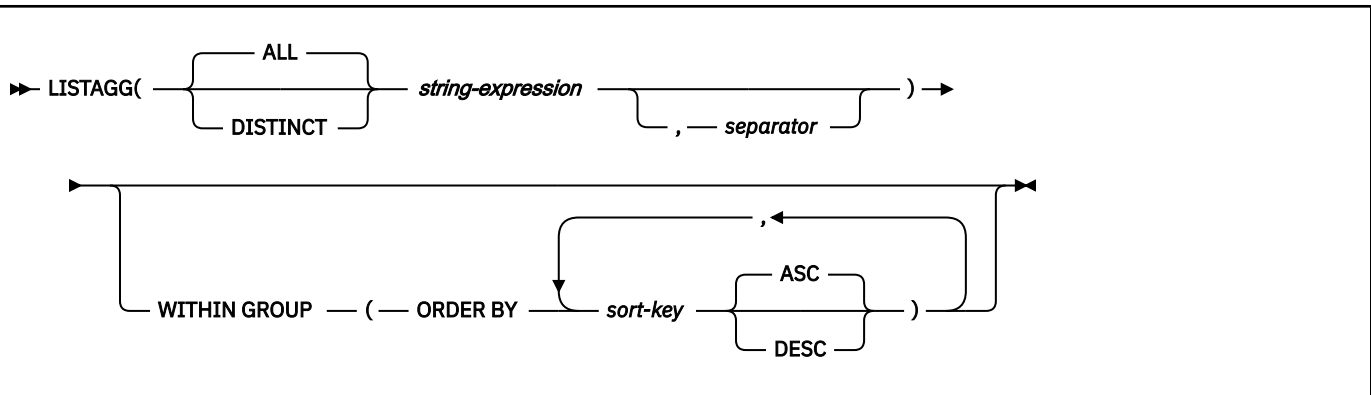

The schema is SYSIBM.

The LISTAGG function aggregates a set of string values for a group into one string by appending the *string-expression* values based on the order that is specified in the WITHIN GROUP clause.

The function is applied to the set of values that are derived from the first argument by the elimination of null values. If a separator argument is specified that is not the null value, the separator value is inserted between each pair of non-null *string-expression* values.

string-expression

An expression that specifies the string values to aggregate. The expression must return a value that is a built-in character string, graphic string, or a binary string data type that is not a LOB. If the value is a CLOB, it is implicitly cast to VARCHAR before the function is evaluated up to a maximum length of 32704. If the value is a DBCLOB, it is implicitly cast to VARGRAPHIC before the function is evaluated up to a maximum length of 16352. If the value is a BLOB, it is implicitly cast to VARBINARY before the function is evaluated up to a maximum length of 32704.

The argument can also be a numeric data type. The numeric argument is implicitly cast to a VARCHAR data type.

If *string-expression* is a column encoded by a field procedure, the decoded value is used in the result.

separator

A constant expression that defines the string that is to be used between non-null *string-expression* values. The expression must return a value that is a built-in character string, graphic string, or a binary string data type.

LOBs are supported through implicit casting. If the value is a CLOB, it is implicitly cast to VARCHAR before the function is evaluated up to a maximum length of 32704. If the value is a DBCLOB, it is implicitly cast to VARGRAPHIC before the function is evaluated up to a maximum length of 16352. If the value is a BLOB, it is implicitly cast to VARBINARY before the function is evaluated up to a maximum length of 32704.

The separator can be a literal, special register, variable, or an expression that is based on literals, special registers, or variables, provided that the expression does not include a non-deterministic function or a function that takes an external action.

WITHIN GROUP

Indicates that the aggregation follows the specified ordering within the grouping set.

If WITHIN GROUP is not specified, the ordering of strings within the result is not deterministic.

ORDER BY

Specifies the order of the rows from the same grouping set that are processed in the aggregation. If the ORDER BY clause cannot distinguish the order of the column data, the rows in the same grouping set are arbitrarily ordered.

sort-key

The sort key can be a column name or a *sort-key-expression*. If the sort key is a constant, it does not refer to the position of the output column (as in the ORDER BY clause of a query); It is a constant, which implies no sort key.

If the sort key value is a constant, the constant does not refer to the position of the output column, but is simply a constant, which implies that there is no sort key.

sort-key must not include a scalar fullselect, or any function that is non-deterministic or has an external action. *sort-key* must not reference a column for which a column mask is defined.

If *sort-key* is encoded by a field procedure, the encoded value determines the order.

ASC

Processes the *sort-key* in ascending order. This is the default option.

DESC

Processes the *sort-key* in descending order.

Result

The result data type of LISTAGG is based on the data type of *string-expression*, as shown in the following table:

Data type of string-expression	Result data type and length
CHAR(<i>n</i>) or VARCHAR(<i>n</i>)	VARCHAR(MIN(MAX(4000, <i>n</i>), 32704))
GRAPHIC(<i>n</i>) or VARGRAPHIC(<i>n</i>)	VARGRAPHIC(MIN(MAX(2000, <i>n</i>), 16352))
BINARY(<i>n</i>) or VARBINARY(<i>n</i>)	VARBINARY(MIN(MAX(4000, <i>n</i>), 32704))

The result data type can exceed VARCHAR(4000), VARBINARY(4000), or VARGRAPHIC(2000), if a derived size is used to determine the size of the result. The maximum possible value is the maximum for the result data type. The following example yields a return data type of VARCHAR(10000):

```
LISTAGG(CAST(NAME AS VARCHAR(10000)), ',')
```

If the actual length of the aggregated result string exceeds the maximum for the result data type, an error is returned.

The result can be null. If the function is applied to an empty set, or all of the *string-expression* values in the set are null values, the result is a null value.

The following rules also apply:

- If the *string-expression* and *separator* are both bit data, the result is bit data. Otherwise, neither *string-expression* nor *separator* can be bit data.
- If *string-expression* and *separator* are both SBCS Unicode data, the CCSID of the result is the CCSID for SBCS Unicode data.
- If *string-expression* is SBCS Unicode data, and *separator* is not SBCS Unicode data, the CCSID of the result is the mixed CCSID for Unicode data.
- Otherwise, the CCSID of the result is the mixed CCSID that corresponds to the CCSID of *string-expression*. However, if the input is EBCDIC or ASCII and there is no corresponding system CCSID for mixed, the CCSID of the result is the CCSID of *string-expression*.

Results for accelerators: When multiple tables are joined, the result can differ when LISTAGG runs on an accelerator instead of Db2 for z/OS. To guarantee the same result from both environments, you can use an ORDER BY clause in a unique *sort-key* expression. This approach ensures that the result set is the always the same. However, the order of rows in the result can still differ, unless the statement also specifies a unique GROUP BY clause for the *sort-key* expression.

Rules

The following restrictions apply to LISTAGG:

- LISTAGG cannot be used as part of an OLAP specification.
- If DISTINCT is specified for LISTAGG, ORDER BY must be specified and the first *sort-key* of the ORDER BY specification must exactly match *string-expression*.
- A fullselect that contains an invocation of LISTAGG cannot contain an ORDER BY clause.
- A fullselect that contains an invocation of LISTAGG cannot contain a DISTINCT keyword in its SELECT list.
- A SELECT clause that includes an invocation of the LISTAGG function must not also include an invocation of the ARRAY_AGG function or the XMLAGG function.

Example

Produce an alphabetical list of comma-separated names, grouped by department, from the sample employee table.

```
SELECT WORKDEPT,
       LISTAGG(LASTNAME, ', ') WITHIN GROUP(ORDER BY LASTNAME)
  AS EMPLOYEES
FROM EMP
GROUP BY WORKDEPT;
```

The following result is returned.

```
-----+-----+-----+-----+-----+-----+-----+-----+-----+-----+
WORKDEPT  EMPLOYEES
-----+-----+-----+-----+-----+-----+-----+-----+-----+-----+
A00       HAAS, HEMMINGER, LUCCHESI, O'CONNELL, ORLANDO
B01       THOMPSON
C01       KWAN, NATZ, NICHOLLS, QUINTANA
D11       ADAMSON, BROWN, JOHN, JONES, LUTZ, PIANKA, SCOUTTEN, STERN, WALKER, YAMAMOTO, YOSHIMURA
D21       JEFFERSON, JOHNSON, MARINO, MONTEVERDE, PEREZ, PULASKI, SMITH
E01       GEYER
E11       HENDERSON, PARKER, SCHNEIDER, SCHWARTZ, SETRIGHT, SMITH, SPRINGER
E21       ALONZO, GOUNOT, LEE, MEHTA, SPENSER, WONG
```

Related reference

[Employee table \(DSN8C10.EMP\) \(Introduction to Db2 for z/OS\)](#)

[Function level 501 \(PI70535 - May 2017\) \(Db2 for z/OS What's New?\)](#)

Related information

[Grouping values by using the LISTAGG function \(Db2 Programming samples\)](#)

MAX aggregate function

The MAX function returns the maximum value in a set of values of a group.

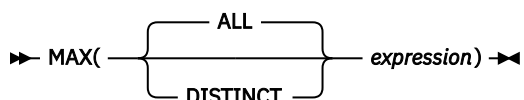

The schema is SYSIBM.

The arguments must be compatible. For more information on compatibility, refer to the compatibility matrix in [Table 30 on page 144](#). All arguments except the first argument can be parameter markers.

expression

An expression that returns the value of a built-in data type. Each expression must return a value that is not a CLOB, DBCLOB, BLOB, ROWID, or XML. Character string arguments and binary string arguments cannot have a length attribute greater than 32704, and graphic string arguments cannot have a length attribute greater than 16352.

If there are any mixed character string or graphic string and numeric arguments, the string value is implicitly cast to a DECFLOAT(34) value.

The result of the function is the largest argument value. The data type of the result and its other attributes (for example, the length and CCSID of a string or a datetime value) are the same as the data type and attributes of the argument values. The result can be null.

The function is applied to the set of values derived from the argument values by the elimination of null values.

If the function is applied to an empty set, the result is the null value. Otherwise, the result is the maximum value in the set.

The specification of DISTINCT has no effect on the result and is not advised.

Examples

Example 1: Set the DECIMAL(8,2) variable MAX_SALARY to the maximum monthly salary of the employees represented in the sample table DSN8C10.EMP.

```
EXEC SQL SELECT MAX(SALARY) / 12
INTO :MAX_SALARY
FROM DSN8C10.EMP;
```

Example 2: Find the surname that comes last in the collating sequence for the employees represented in the sample table DSN8C10.EMP. Set the VARCHAR(15) variable LAST_NAME to that surname.

```
EXEC SQL SELECT MAX(LASTNAME)
INTO :LAST_NAME
FROM DSN8C10.EMP;
```

MEDIAN aggregate function

The MEDIAN function returns the median of a set of numbers.

►► MEDIAN(*numeric-expression*) ◄◄

The schema is SYSIBM.

numeric-expression

An expression that returns a built-in numeric data type. *numeric-expression* must not include a scalar fullselect, or invoke a function that is non-deterministic or has an external action. *numeric-expression* must not reference a column for which a column mask is defined

If the argument is DECFLOAT(*n*), the result of the function is DECFLOAT(34). Otherwise, the result of the function is a double precision floating-point number.

The function is applied to the set of values that are derived from the argument values by the elimination of null values.

The result can be null. If *numeric-expression* is null or if the function is applied to the empty set, the result is the null value.

Specifying MEDIAN(*numeric-expression*) is equivalent to specifying PERCENTILE_CONT(0.5) WITHIN GROUP (ORDER BY *numeric-expression*).

Examples for MEDIAN

- The following statement calculates the median salary of the employees in department D11 from the EMPLOYEE table.

```
SELECT MEDIAN(SALARY)
FROM EMPLOYEE
WHERE WORKDEPT = 'D11';
```

The result is 24680.00. Department D11 has 11 employees. The middle row of a group of 11 values is the sixth row. The result of MEDIAN over that group is the value of the sixth row, which is 24680.00.

- The following statement calculates the median salary of the employees in department E21 from the EMPLOYEE table.

```
SELECT MEDIAN(SALARY)
FROM EMPLOYEE
WHERE WORKDEPT = 'E21';
```

The result is 24605.00. Department E21 has six employees. Because there are an even number of rows, the MEDIAN is computed by interpolating a value between the middle two rows. The middle two rows are the third row with the value 23840.00 and the fourth row with the value 25370.00. MEDIAN is computed by averaging those two values, which is 24605.00.

- The following statement calculates the median salary of the employees in department E21 from the EMPLOYEE table.

```
SELECT MEDIAN(SALARY)
FROM EMPLOYEE
WHERE WORKDEPT = 'E21';
```

The result is 24605.00. Department E21 has six employees. Because there are an even number of rows, the MEDIAN is computed by interpolating a value between the middle two rows. The middle two rows are the third row with the value 23840.00 and the fourth row with the value 25370.00. MEDIAN is computed by averaging those two values, which is 24605.00.

Notes for MEDIAN

When EXPLAIN is issued against an SQL statement that references the MEDIAN function, but the statement cannot be run on the accelerator server for any reason, the following values are populated in the PLAN_TABLE table:

- For a SELECT statement, column QBLOCK_TYPE would have the value 'PRUNED', and column ACESSTYPE would have the value '' (blank).
- For an INSERT statement with a subselect, the PLAN_TABLE rows for the subselect would have column QBLOCK_TYPE with the value 'NCOSUB', and column ACESSTYPE with the value '' (blank).

Also, when a view is referenced in an SQL statement that uses the MEDIAN function, the tables referred to in the view must be enabled for acceleration. Those tables referred to in the view do not need to be enabled for acceleration when the view is created.

MIN aggregate function

The MIN function returns the minimum value in a set of values of a group.

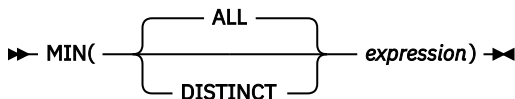

The schema is SYSIBM.

The arguments must be compatible. For more information on compatibility, refer to the compatibility matrix in [Table 30 on page 144](#). All arguments except the first argument can be parameter markers.

expression

An expression that returns the value of a built-in data type. Each expression must return a value that is not a CLOB, DBCLOB, BLOB, ROWID, or XML. Character string arguments and binary string arguments cannot have a length attribute greater than 32704, and graphic string arguments cannot have a length attribute greater than 16352.

If there are any mixed character string or graphic string and numeric arguments, the string value is implicitly cast to a DECFLOAT(34) value.

The result of the function is the smallest argument value. The data type of the result and its other attributes (for example, the length and CCSID of a string or a datetime value) are the same as the data type and attributes of the argument values. The result can be null.

The function is applied to the set of values derived from the argument values by the elimination of null values.

If the function is applied to an empty set, the result is the null value. Otherwise, the result is the minimum value in the set.

The specification of DISTINCT has no effect on the result and is not advised.

Examples

Example 1: Set the DECIMAL(15,2) variable *MIN_SALARY* to the minimum monthly salary of the employees represented in the sample table DSN8C10.EMP.

```
EXEC SQL SELECT MIN(SALARY) / 12
          INTO :MIN_SALARY
          FROM DSN8C10.EMP;
```

Example 2: Find the surname that comes first in the collating sequence for the employees represented in the sample table DSN8C10.EMP. Set the VARCHAR(15) variable *LAST_NAME* to that surname.

```
EXEC SQL SELECT MIN(LASTNAME)
          INTO :LAST_NAME
          FROM DSN8C10.EMP;
```

PERCENTILE_CONT aggregate function

The PERCENTILE_CONT function returns a percentile of a set of values. The set of values is treated as a continuous distribution. The calculated percentile is an interpolated value that might not have appeared in the input set.

► PERCENTILE_CONT(*percentile-expr*) — WITHIN GROUP — (— ORDER BY — *sort-expression* — { ASC / DESC }) —►

The schema is SYSIBM.

percentile-expr

Specifies the percentile that is to be calculated by the function. *percentile-expr* must return a built-in numeric, character, or graphic string data type that is not a LOB. If the value is not a numeric data type it is cast to DECFLOAT(34) before the function is evaluated. The value must be in the range 0–1.

WITHIN GROUP

Specifies that the percentile is to be calculated over the rows that are identified in the group.

sort-expression

Specifies the set of values over which to calculate the percentile and the order of the set. *sort-expression* must return a built-in numeric data type. A string value is implicitly cast to a numeric value. *sort-expression* must not include a scalar fullselect, or any function that is non-deterministic or has an external action. *sort-key-expression* must not reference a column for which a column mask is defined.

ASC

Specifies that the percentile is calculated using values from *sort-expression* in ascending order.

DESC

Specifies that the percentile is calculated using values from *sort-expression* in descending order.

The result is the value at the percentile that is specified by *percentile-expr* over the set of values identified by *sort-expression*.

For PERCENTILE_CONT, the set of values is treated as a continuous distribution. The calculated percentile is a interpolated value that might not have appeared in the input set. If the argument is DECFLOAT(*n*), the result of the function is DECFLOAT(34). Otherwise, the result of the function is a double-precision floating point number.

The function is applied to the set of values that are derived from *sort-expression* by the elimination of null values.

The result can be null. If *percentile-expr* is null, or if the function is applied to an empty set, the result is the null value.

The result of using PERCENTILE_CONT(0.5) WITHIN GROUP (ORDER BY *sort-expression*) is equivalent to MEDIAN(*numeric-expression*).

Examples for PERCENTILE_CONT

- This example calculates the median salary of the employees in department D11 from the EMP table.

```
SELECT PERCENTILE_CONT(0.5) WITHIN GROUP (ORDER BY SALARY)
FROM DSN8C10.EMP
WHERE WORKDEPT = 'D11';
```

The result is 24,680.00. Department D11 has 11 employees. The middle row of a group of 11 values in the sixth row. Because there are an odd number of rows, the PERCENTILE_CONT function for the percentile 0.5 returns the value of the sixth row, which is 24,680.00.

- This example calculates the median commission of the employees in department E21 from the EMP table.

```
SELECT PERCENTILE_CONT(0.5) WITHIN GROUP (ORDER BY COMM)
FROM DSN8C10.EMP
WHERE WORKDEPT = 'E21';
```

The result is 1968.50. This example has an even number of rows, so the PERCENTILE_CONT function is computed by interpolating a value between the two middle rows. The two middle rows are row three with a value of 1907.00 and row four with a value of 2030.00. PERCENTILE_CONT is computed by averaging those two values, which is 1968.50.

- This example calculates the 95th percentile of total salary per department from the EMP table.

```
SELECT PERCENTILE_CONT(0.95) WITHIN GROUP (ORDER BY SALARY+BONUS)
FROM DSN8C10.EMP
GROUP BY WORKDEPT;
```

PERCENTILE_DISC aggregate function

The PERCENTILE_DISC function returns a percentile of a set of values. Each value in the input set is treated as a discrete value. The calculated percentile is always a value that appeared in the input set.

► PERCENTILE_DISC(*percentile-expr*) — WITHIN GROUP — (— ORDER BY — *sort-expression* — { ASC / DESC }) ►

The schema is SYSIBM.

percentile-expr

Specifies the percentile that is to be calculated by the function. *percentile-expr* must return a built-in numeric, character, or graphic string data type that is not a LOB. If the value is not a numeric data type is cast to DECFLOAT(34) before the function is evaluated. The value must be in the range 0–1.

WITHIN GROUP

Specifies that the percentile is to be calculated over the rows that are identified in the group.

sort-expression

Specifies the set of values over which to calculate the percentile and the order of the set. *sort-expression* must return a built-in numeric data type. *sort-expression* must not include a scalar fullselect, or any function that is non-deterministic or has an external action. *sort-key-expression* must not reference a column for which a column mask is defined.

ASC

Specifies that the percentile is calculated using values from *sort-expression* in ascending order.

DESC

Specifies that the percentile is calculated using values from *sort-expression* in descending order.

The result is the value at the percentile that is specified by *percentile-expr* over the set of values identified by *sort-expression*.

For PERCENTILE_DISC, each value in the input set is treated as a discrete value. The calculated percentile is always a value that appeared in the input set. The data type of the result is the same as the data type of the result of *sort-expression*.

The function is applied to the set of values that are derived from *sort-expression* by the elimination of null values.

The result can be null. If *percentile-expr* is null, or if the function is applied to an empty set, the result is the null value.

Examples for PERCENTILE_DISC

- This example calculates the median salary as a discrete value of the employees in department D11 from the EMP table.

```
SELECT PERCENTILE_DISC(0.5) WITHIN GROUP (ORDER BY SALARY)
FROM DSN8C10.EMP
WHERE WORKDEPT = 'D11';
```

The result is 24,680.00. Department D11 has 11 employees. The middle row of a group of 11 values in the sixth row. Because there are an odd number of rows, the PERCENTILE_DISC function for the percentile 0.5 returns the value of the sixth row, which is 24,680.00.

- This example calculates the median commission as a discrete value of the employees in department E21 from the EMP table.

```
SELECT PERCENTILE_DISC(0.5) WITHIN GROUP (ORDER BY COMM)
FROM DSN8C10.EMP
WHERE WORKDEPT = 'E21';
```

The result is 1907.00. This example has six rows, which is an even number of rows. The PERCENTILE_DISC function is computed by returning the value of the first of the two middle rows, which is row three with a value of 1907.00.

- This example calculates the 95th percentile of total salary per department from the EMP table.

```
SELECT PERCENTILE_DISC(0.95) WITHIN GROUP (ORDER BY SALARY+BONUS)
FROM DSN8C10.EMP
GROUP BY WORKDEPT;
```

PERCENT_RANK aggregate function

The PERCENT_RANK function returns the relative percentile rank of a row that is hypothetically inserted into a group of rows.

FL 504

Passthrough-only expression: This function is passthrough-only and cannot run on Db2 for z/OS without acceleration. For information about invoking this function, see [Accelerating queries with passthrough-only expressions](#).

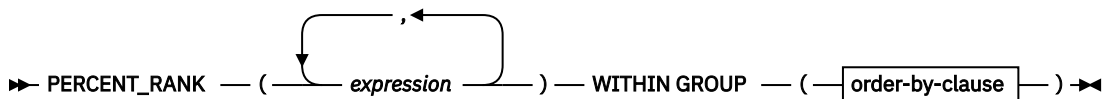

order-by-clause

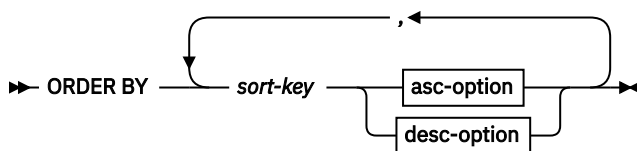

asc-option

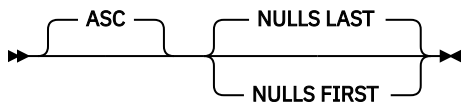

desc-option

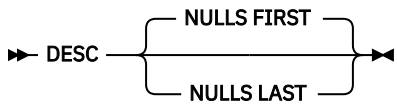

The schema is SYSIBM.

expression

An expression that specifies a row that is hypothetically inserted into a group of rows. The expression must return a value that is a built-in data type. The expression must be a constant, a variable, or a cast of a constant or variable.

order-by-clause

ORDER BY

Specifies the order of the rows from the same grouping set that are processed in the aggregation.

sort-key

The sort key can be a column name or a *sort-key-expression*. If the sort key is a constant, it does not refer to the position of the output column. A constant implies no sort key, unlike a constant in the ordinary ORDER BY clause.

ASC

Uses the values of the *sort-key* in ascending order.

DESC

Uses the values of the *sort-key* in descending order.

NULLS FIRST

The ordering considers null values before all non-null values in the sort order.

NULLS LAST

The ordering considers null values after all non-null values in the sort order.

The number of expressions must be the same as the number of *sort-key* expressions. The data type of each expression and the data type of the corresponding *sort-key* expression must be compatible.

The data type of the result is DECFLOAT(34). The actual result is greater than 0.0 and less than or equal to 1.0.

Example

Set the host variable PR to the relative percentile rank of a hypothetical new employee's salary of 47000 within the salaries of the employees in department 'A00'.

```
SELECT PERCENT_RANK(47000) WITHIN GROUP (ORDER BY SALARY)
INTO :PR FROM EMPLOYEE WHERE WORKDEPT = 'A00'
```

PR is set to a value of 0.4.

The following result set is shown for reference.

```
SELECT SALARY FROM EMPLOYEE WHERE WORKDEPT = 'A00' ORDER BY SALARY

SALARY
-----
39250.00
46500.00
49250.00
66500.00
152750.00

5 record(s) selected.
```

Related concepts

[How Db2 determines whether to accelerate eligible queries \(Db2 Performance\)](#)

Regression functions (REGR_AVGX, REGR_AVGY, REGR_COUNT, ...)

The regression functions support the fitting of an ordinary-least-squares regression line of the form $y = a * x + b$ to a set of number pairs.

FL 507

Passthrough-only expression: This function is passthrough-only and cannot run on Db2 for z/OS without acceleration. For information about invoking this function, see [Accelerating queries with passthrough-only expressions](#).

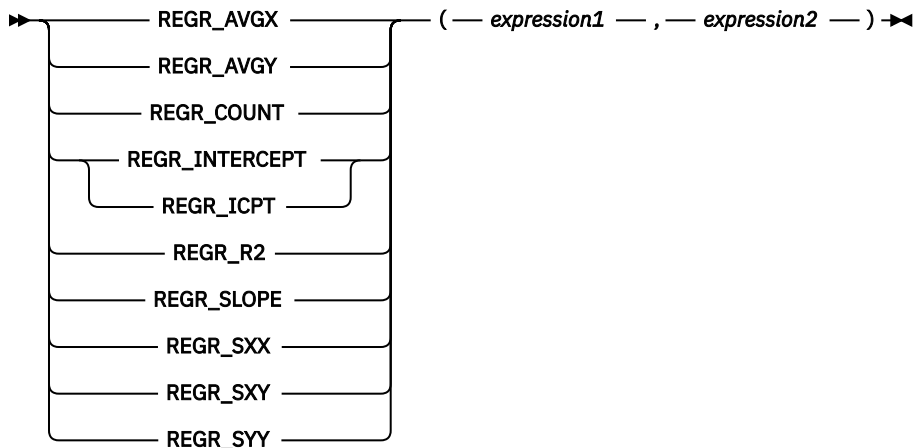

The schema is SYSIBM.

expression1

An expression that returns a value of any built-in numeric data type. It is interpreted as a value of the dependent variable (that is, a "y value").

expression2

An expression that returns a value of any built-in numeric data type. It is interpreted as a value of the independent variable (that is, an "x value").

The REGR_COUNT function returns the number of non-null number pairs used to fit the regression line.

The REGR_INTERCEPT (or REGR_ICPT) function returns the y-intercept of the regression line ("b" in the equation mentioned previously).

The REGR_R2 function returns the coefficient of determination ("R-squared" or "goodness-of-fit") for the regression.

The REGR_SLOPE function returns the slope of the line ("a" in the equation mentioned previously).

The REGR_AVGX, REGR_AVGY, REGR_SXX, REGR_SXY, and REGR_SYY functions return quantities that can be used to compute various diagnostic statistics needed for the evaluation of the quality and statistical validity of the regression model.

The data type of the result of REGR_COUNT is integer. For the remaining functions, if either argument is DECFLOAT(*n*), the data type of the result is DECFLOAT(34); otherwise, the data type of the result is double-precision floating-point. If either argument is a special decimal floating-point value, the rules for general arithmetic operations for decimal floating-point apply. For more information, see ["General arithmetic operation rules for DECFLOAT"](#) on page 254

The result can be null. When not null, the result of REGR_R2 is in the range 0–1, and the result of both REGR_SXX and REGR_SYY is non-negative.

Each function is applied to the set of (*expression1*, *expression2*) pairs derived from the argument values by the elimination of all pairs for which either *expression1* or *expression2* is null.

If the set is not empty and $VARIANCE(expression2)$ is positive, $REGR_COUNT$ returns the number of non-null pairs in the set, and the remaining functions return results that are defined as follows:

```
REGR_SLOPE(expression1,expression2) =  
COVARIANCE(expression1,expression2)/VARIANCE(expression2)
```

```
REGR_INTERCEPT(expression1, expression2) =  
AVG(expression1) - REGR_SLOPE(expression1, expression2) * AVG(expression2)
```

```
REGR_R2(expression1, expression2) =  
POWER(CORRELATION(expression1, expression2), 2) if VARIANCE(expression1)>0  
REGR_R2(expression1, expression2) = 1 if VARIANCE(expression1)=0
```

```
REGR_AVGX(expression1, expression2) = AVG(expression2)
```

```
REGR_AVGY(expression1, expression2) = AVG(expression1)
```

```
REGR_SXX(expression1, expression2) =  
REGR_COUNT(expression1, expression2) * VARIANCE(expression2)
```

```
REGR_SYY(expression1, expression2) =  
REGR_COUNT(expression1, expression2) * VARIANCE(expression1)
```

```
REGR_SXY(expression1, expression2) =  
REGR_COUNT(expression1, expression2) * COVARIANCE(expression1, expression2)
```

If the set is not empty and $VARIANCE(expression2)$ is equal to zero, then the regression line either has infinite slope or is undefined. In this case, the functions $REGR_SLOPE$, $REGR_INTERCEPT$, and $REGR_R2$ each return a null value, and the remaining functions return values as defined previously. If the set is empty, $REGR_COUNT$ returns zero and the remaining functions return a null value.

The order in which the values are aggregated is undefined, but every intermediate result must be within the range of the result data type.

The regression functions are all computed simultaneously during a single pass through the data. In general, it is more efficient to use the regression functions to compute the statistics needed for a regression analysis than to perform the equivalent computations using ordinary column functions such as $AVERAGE$, $VARIANCE$, $COVARIANCE$, and so forth.

The usual diagnostic statistics that accompany a linear-regression analysis can be computed in terms of the functions listed previously. For example:

Adjusted R2

$$1 - ((1 - REGR_R2) * ((REGR_COUNT - 1) / (REGR_COUNT - 2)))$$

Standard error

$$\text{SQRT}((REGR_SYY - (\text{POWER}(REGR_SXY, 2) / REGR_SXX)) / (REGR_COUNT - 2))$$

Total sum of squares

$$REGR_SYY$$

Regression sum of squares

$$\text{POWER}(REGR_SXY, 2) / REGR_SXX$$

Residual sum of squares

$$(\text{Total sum of squares}) - (\text{Regression sum of squares})$$

t statistic for slope

$$REGR_SLOPE * \text{SQRT}(REGR_SXX) / (\text{Standard error})$$

t statistic for y-intercept

$$REGR_INTERCEPT / ((\text{Standard error}) * \text{SQRT}((1 / REGR_COUNT) + (\text{POWER}(REGR_AVGX, 2) / REGR_SXX)))$$

Examples

- Using the EMPLOYEE table, compute an ordinary-least-squares regression line that expresses the bonus of an employee in department (WORKDEPT) 'A00' as a linear function of the employee's salary. Set the host variables SLOPE, ICPT, RSQR (double-precision floating point) to the slope, intercept, and coefficient of determination of the regression line, respectively. Also set the host variables AVGSAL and AVGBONUS to the average salary and average bonus, respectively, of the employees in department 'A00', and set the host variable CNT (integer) to the number of employees in department 'A00' for whom both salary and bonus data are available. Store the remaining regression statistics in host variables SXX, SYY, and SXY.

```
SELECT REGR_SLOPE(BONUS,SALARY), REGR_INTERCEPT(BONUS,SALARY),
REGR_R2(BONUS,SALARY), REGR_COUNT(BONUS,SALARY),
REGR_AVGX(BONUS,SALARY), REGR_AVGY(BONUS,SALARY),
REGR_SXX(BONUS,SALARY), REGR_SYY(BONUS,SALARY),
REGR_SXY(BONUS,SALARY)
INTO :SLOPE, :ICPT,
:RSQR, :CNT,
:AVGSAL, :AVGBONUS,
:SXX, :SYY,
:SXY
FROM EMPLOYEE
WHERE WORKDEPT = 'A00'
```

When using the sample table, the host variables are set to the following approximate values:

```
SLOPE: +1.71002671916749E-002
ICPT: +1.00871888623260E+002
RSQR: +9.99707928128685E-001
CNT: 3
AVGSAL: +4.28333333333333E+004
AVGBONUS: +8.33333333333333E+002
SXX: +2.96291666666667E+008
SYY: +8.66666666666667E+004
SXY: +5.06666666666667E+006
```

STDDEV_POP or STDDEV aggregate function

The STDDEV_POP function returns the population standard deviation (division by n) of a set of numbers.

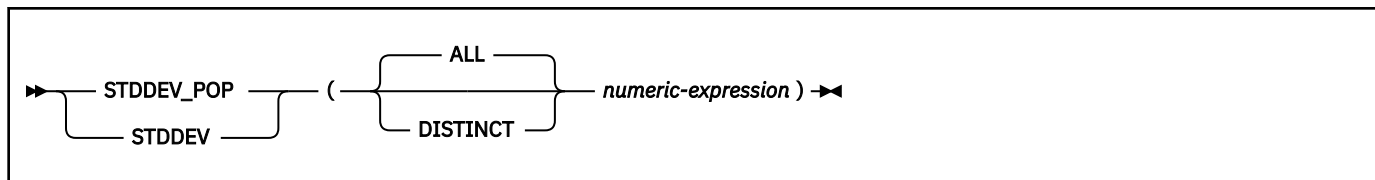

The schema is SYSIBM.

The formula that is used to calculate the result is logically equivalent to:

```
STDDEV_POP = SQRT(VAR_POP)
```

The argument values must each be the value of any built-in numeric data type, and their sum must be within the range of the data type of the result.

The arguments can also be a character string or graphic string data type. The string input is implicitly cast to a numeric value of DECFLOAT(34).

If the argument is DECFLOAT(n), the result of the function is DECFLOAT(34). Otherwise, the result of the function is double precision floating-point. The result can be null.

Before the function is applied to the set of values derived from the argument values, null values are eliminated. If DISTINCT is specified, redundant duplicate values are also eliminated.

If the function is applied to an empty set, the result is the null value. Otherwise, the result is the population standard deviation of the values in the set.

The order in which the values are aggregated is undefined, but every intermediate result must be within the range of the result data type.

Notes

Syntax alternatives:

STDDEV_POP should be used for conformance to the SQL standard.

Example

Using sample table DSN8C10.EMP, set the host variable DEV, which is defined as double precision floating-point, to the population standard deviation of the salaries for the employees in department 'A00' (WORKDEPT='A00').

```
SELECT STDDEV_POP(SALARY)
       INTO :DEV
       FROM DSN8C10.EMP
       WHERE WORKDEPT = 'A00';
```

The value of DEV is set to an approximate value of 9742.43.

STDDEV_SAMP aggregate function

The STDDEV_SAMP function returns the sample standard deviation (division by $n-1$) of a set of numbers.

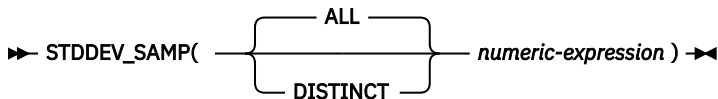

The schema is SYSIBM.

The formula that is used to calculate the result is logically equivalent to:

```
STDDEV_SAMP = SQRT(VAR_SAMP)
```

The argument values must each be the value of any built-in numeric data type, and their sum must be within the range of the data type of the result.

The arguments can also be a character string or graphic string data type. The string input is implicitly cast to a numeric value of DECFLOAT(34).

If the argument is DECFLOAT(n), the result of the function is DECFLOAT(34). Otherwise, the result of the function is double precision floating-point. The result can be null.

Before the function is applied to the set of values derived from the argument values, null values are eliminated. If DISTINCT is specified, redundant duplicate values are also eliminated.

If the function is applied to an empty set, the result is the null value. Otherwise, the result is the sample standard deviation of the values in the set.

The order in which the values are aggregated is undefined, but every intermediate result must be within the range of the result data type.

The following restrictions apply to STDDEV_SAMP:

- STDDEV_SAMP cannot be used as part of an OLAP specification.

Example

Using sample table DSN8C10.EMP, set the host variable DEV, which is defined as double precision floating-point, to the sample standard deviation of the salaries for the employees in department 'A00' (WORKDEPT='A00').

```
SELECT STDDEV_SAMP(SALARY)
INTO :DEV
FROM DSN8C10.EMP
WHERE WORKDEPT = 'A00';
```

The value of DEV is set to approximately 10892.37.

SUM aggregate function

The SUM function returns the sum of a set of numbers.

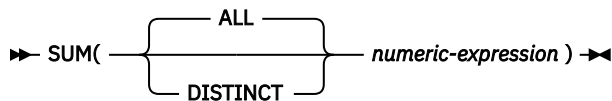

The diagram shows the syntax for the SUM function. It starts with a right-pointing arrow followed by 'SUM(' in bold. A bracketed section contains two options: 'ALL' and 'DISTINCT'. This is followed by 'numeric-expression' in italics, and ends with a right-pointing arrow.

The schema is SYSIBM.

The argument values can be of any built-in numeric data type, and their sum must be within the range of the data type of the result.

The arguments can also be a character string or graphic string data type. The string input is implicitly cast to a numeric value of DECFLOAT(34).

The data type of the result is determined as follows:

- DECFLOAT(34) if the argument is DECFLOAT(*n*).
- Large integer if the argument is small integer.
- Double precision floating-point if the argument is single precision floating-point.
- Otherwise, the result is the same as the data type of the argument.

The result can be null.

If the data type of the argument values is decimal, the scale of the result is the same as the scale of the argument values, and the precision of the result depends on the precision of the argument values and the decimal precision option:

- If the precision of the argument values is greater than 15 or the DEC31 option is in effect, the precision of the result is $\min(31, P+10)$, where *P* is the precision of the argument values.
- Otherwise, the precision of the result is 15.

The function is applied to the set of values derived from the argument values by the elimination of null values. If DISTINCT is specified, redundant duplicate values are also eliminated.

If the function is applied to an empty set, the result is the null value. Otherwise, the result is the sum of the values in the set. The order in which the summation is performed is undefined but every intermediate result must be within the range of the result data type.

Example: Set the large integer host variable *INCOME* to the total income from all sources (salaries, commissions, and bonuses) of the employees represented in the sample table DSN8C10.EMP. If DEC31 is not in effect, the resultant sum is DECIMAL(15,2) because all three columns are DECIMAL(9,2).

```
EXEC SQL SELECT SUM(SALARY+COMM+BONUS)
INTO :INCOME
FROM DSN8C10.EMP;
```

VAR_POP or VARIANCE or VAR aggregate function

The VAR_POP or VARIANCE or VAR function returns the biased variance (division by n) of a set of numbers.

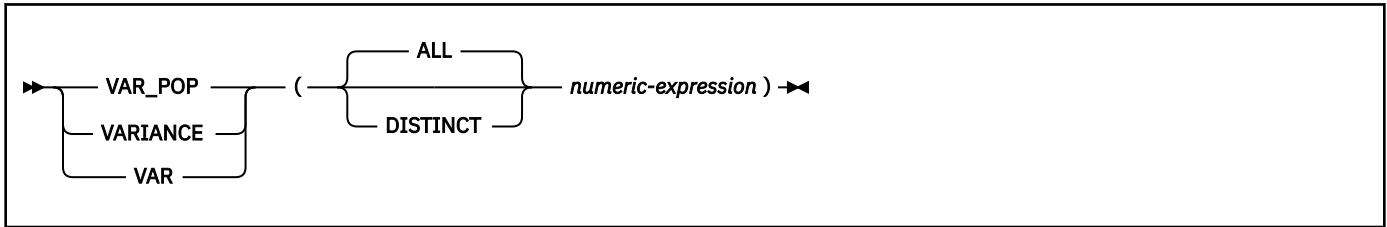

The schema is SYSIBM.

The formula that is used to calculate the result is logically equivalent to:

$$\text{VAR_POP} = \text{SUM}(X**2) / \text{COUNT}(X) - (\text{SUM}(X) / \text{COUNT}(X))**2$$

Two asterisks (**) represent exponentiation. The exponentiation operator is not supported by Db2 for z/OS.

The argument values can be of any built-in numeric type, and their sum must be within the range of the data type of the result. Before the function is applied to the set of values derived from the argument values, null values are eliminated. If DISTINCT is specified, redundant duplicate values are also eliminated.

The arguments can also be a character string or graphic string data type. The string input is implicitly cast to a numeric value of DECFLOAT(34).

If the argument is DECFLOAT(n), the result of the function is DECFLOAT(34). Otherwise, the result of the function is double precision floating-point.

The result can be null; if any argument is null, the result is the null value.

Otherwise, the result is the population variance of the values in the set.

The order in which the values are added is undefined, but every intermediate result must be within the range of the result data type.

Notes

Syntax alternatives:

VAR_POP should be used for conformance to the SQL standard.

Example

Using sample table DSN8C10.EMP, set host variable VARNCE, which is defined as double precision floating-point, to the population variance of the salaries (SALARY) for those employees in department (WORKDEPT) 'A00'.

```
SELECT VAR_POP(SALARY)
  INTO :VARNCE
  FROM DSN8C10.EMP
 WHERE WORKDEPT = 'A00';
```

The value of VARNCE is set to 94915000.

VAR_SAMP or VARIANCE_SAMP aggregate function

The VAR_SAMP or VARIANCE_SAMP function returns the sample variance (division by $n-1$) of a set of numbers.

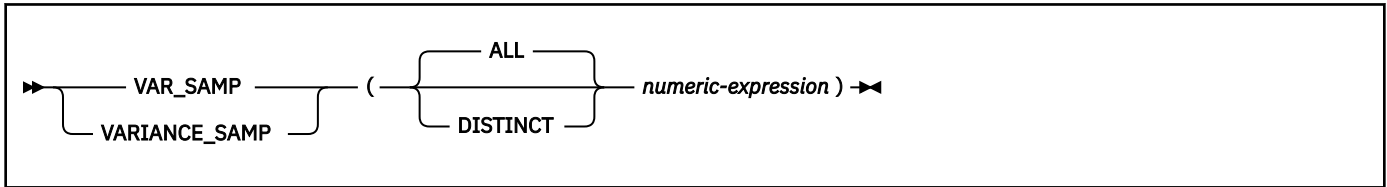

The schema is SYSIBM.

The formula that is used to calculate the result is logically equivalent to:

$$\text{VAR_SAMP} = (\text{SUM}(X^{**2}) - ((\text{SUM}(X)^{**2}) / (\text{COUNT}(*)))) / (\text{COUNT}(*) - 1)$$

Two asterisks (**) represent exponentiation. The exponentiation operator is not supported by Db2 for z/OS.

The argument values can be of any built-in numeric type, and their sum must be within the range of the data type of the result. Before the function is applied to the set of values derived from the argument values, null values are eliminated. If DISTINCT is specified, redundant duplicate values are also eliminated.

The arguments can also be a character string or graphic string data type. The string input is implicitly cast to a numeric value of DECFLOAT(34).

If the argument is DECFLOAT(n), the result of the function is DECFLOAT(34). Otherwise, the result of the function is double precision floating-point.

The result can be null; if any argument is null, the result is the null value.

Otherwise, the result is the sample variance of the values in the set.

The order in which the values are added is undefined, but every intermediate result must be within the range of the result data type.

The following restrictions apply to VAR_SAMP:

- VAR_SAMP cannot be used as part of an OLAP specification.

Notes

Syntax alternatives:

VAR_SAMP should be used for conformance to the SQL standard.

Example

Using sample table DSN8C10.EMP, set host variable VARNCE, which is defined as double precision floating-point, to the sample variance of the salaries (SALARY) for those employees in department (WORKDEPT) 'A00'.

```
SELECT VAR_SAMP(SALARY)
       INTO :VARNCE_S
       FROM DSN8C10.EMP
       WHERE WORKDEPT = 'A00';
```

The value of VARNCE is set to 1186437500.

XMLAGG aggregate function

The XMLAGG function returns an XML sequence that contains an item for each non-null value in a set of XML values.

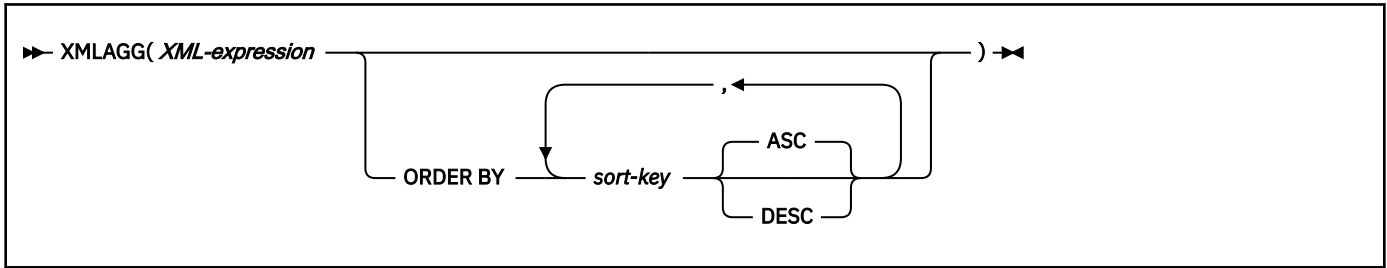

sort-key



The schema is SYSIBM.

XML-expression

An expression that returns an XML value.

Unlike the arguments for other aggregate functions, a scalar fullselect is allowed in *XML-expression*.

ORDER BY

Specifies the order of the rows from the same grouping set that are processed in the aggregation. If the ORDER BY clause is not specified, or if the ORDER BY clause cannot differentiate the order of the sort key value, the rows in the same grouping set are arbitrarily ordered.

sort-key

Specifies a sort key value that is either a column name or an expression. The data type of the column or expression must not be a LOB or an XML value. A character string expression cannot have a length greater than 4000 bytes. If the sort key value is a constant, it does not refer to the position of the output column (as in the ordinary ORDER BY clause), but is simply a constant, which implies no sort key.

The ordering is based on the values of the sort keys, which might or might not be used in *XML-expression*.

If the sort key value is a character string that uses an encoding scheme other than Unicode, the ordering might be different. For example, a column PRODCODE uses EBCDIC. For two values, ('P001' and 'PA01'), relationship 'P001' > 'PA01' is true in EBCDIC, whereas 'P001' < 'PA01' is true in UTF-8. If the same sort key values are used in *XML-expression*, use the CAST specification to convert the sort key to Unicode to keep the ordering of XML values consistent with that of the sort key.

The function is applied to the set of values derived from the argument values by the elimination of null values.

The result can be null; if all *XML-expression* arguments are null. If the function is applied to an empty set, the result is the null value. Otherwise, the result is an XML sequence that contains an item for each value in the set.

The following restrictions apply to XMLAGG:

- XMLAGG cannot be used as part of an OLAP specification.
- A SELECT clause that includes an invocation of the XMLAGG function must not also include an invocation of the ARRAY_AGG function or the LISTAGG function.

Example: Group employees by their department, generate a 'Department' element for each department with its name as the attribute, nest all the 'emp' elements for employees in each department, and order the 'emp' elements by 'lname.'

```
SELECT XMLSERIALIZE(XMLDOCUMENT
  ( XMLELEMENT
    ( NAME "Department",
      XMLATTRIBUTES ( e.dept AS "name" ),
      XMLAGG ( XMLELEMENT ( NAME "emp", e.lname)
                ORDER BY e.lname)
            ) ) AS "dept_list"
      AS CLOB(1M))
FROM employees e
GROUP BY dept;
```

The result of the query would look similar to the following result:

```
dept_list
-----
<Department name="Accounting">
  <emp>SMITH</emp>
  <emp>Yates</emp>
</Department>
<Department name="Shipping">
  <emp>Martin</emp>
  <emp>Oppenheimer</emp>
</Department>
-----
```

Scalar functions

A scalar function can be used wherever an expression can be used. The restrictions on the use of aggregate functions do not apply to scalar functions, because a scalar function is applied to single set of parameter values rather than to sets of values. The argument of a scalar function can be a function. However, the restrictions that apply to the use of expressions and aggregate functions also apply when an expression or aggregate function is used within a scalar function. For example, the argument of a scalar function can be an aggregate function only if an aggregate function is allowed in the context in which the scalar function is used.

If the argument of a scalar function is a string from a column with a field procedure, the function applies to the decoded form of the value and the result of the function does not inherit the field procedure.

Example: The following SELECT statement calls for the employee number, last name, and age of each employee in department D11 in the sample table DSN8C10.EMP. To obtain the ages, the scalar function YEAR is applied to the expression:

```
CURRENT DATE - BIRTHDATE
```

in each row of DSN8C10.EMP for which the employee represented is in department D11:

```
SELECT EMPNO, LASTNAME, YEAR(CURRENT DATE - BIRTHDATE)
FROM DSN8C10.EMP
WHERE WORKDEPT = 'D11';
```

ABS or ABSVAL scalar function

The ABS function returns the absolute value of a number.



The schema is SYSIBM.

The argument must be an expression that returns a value of any built-in numeric data type.

The arguments can also be a character string or graphic string data type. The string input is implicitly cast to a numeric value of DECFLOAT(34).

The result of the function has the same data type and length attribute as the argument.

The result can be null; if the argument is null, the result is the null value.

Notes

Syntax alternatives:

ABS should be used for conformance to the SQL standard.

Example

Assume that host variable PROFIT is a large integer with a value of -50000. The following statement returns a large integer with a value of 50000.

```
SELECT ABS(:PROFIT)
FROM SYSIBM.SYSDUMMY1;
```

ACOS scalar function

The ACOS function returns the arc cosine of the argument as an angle, expressed in radians. The ACOS and COS functions are inverse operations.

►► ACOS(*numeric-expression*) ◄◄

The schema is SYSIBM.

The argument must be an expression that returns the value of any built-in numeric data type except for DECFLOAT. The value must be greater than or equal to -1 and less than or equal to 1. If the argument is not a double precision floating-point number, it is converted to one for processing by the function.

The result of the function is a double precision floating-point number.

The result can be null; if the argument is null, the result is the null value.

Example: Assume that host variable ACOSINE is DECIMAL(10,9) with a value of 0.070737202. The following statement:

```
SELECT ACOS(:ACOSINE)
FROM SYSIBM.SYSDUMMY1;
```

returns a double precision floating-point number with an approximate value of 1.49.

ADD_DAYS scalar function

The ADD_DAYS function returns a datetime value that represents the first argument plus a specified number of days.

FL 507

Passthrough-only expression: This function is passthrough-only and cannot run on Db2 for z/OS without acceleration. For information about invoking this function, see [Accelerating queries with passthrough-only expressions](#).

►► ADD_DAYS — (— *expression* — , — *numeric-expression* —) ◄◄

The schema is SYSIBM.

expression

An expression that specifies the starting date. The expression must return a value that is a DATE, TIMESTAMP WITHOUT TIME ZONE, CHAR, VARCHAR, GRAPHIC, or VARGRAPHIC data type. CHAR, VARCHAR, GRAPHIC, and VARGRAPHIC are supported by using implicit casting. If *expression* is a CHAR, VARCHAR, GRAPHIC, or VARGRAPHIC data type, it must be a valid string that is accepted by the TIMESTAMP scalar function and does not contain a time zone.

numeric-expression

An expression that specifies the number of days to add to the starting date specified by *expression*. The expression must return a value that is a built-in numeric, CHAR, VARCHAR, GRAPHIC, or VARGRAPHIC data type. CHAR, VARCHAR, GRAPHIC, and VARGRAPHIC are supported by using implicit casting. If the expression is not an INTEGER, it is cast to INTEGER before the function is evaluated. A negative numeric value can be used to subtract days.

The result of the function is a timestamp with the same precision as *expression*, if *expression* is a timestamp. Otherwise, the result of the function is a date. If any argument can be null, the result can be null; if any argument is null, the result is the null value.

Examples

- Assume that today is January 31, 2007. Set the host variable ADD_DAY with the current day plus 1 day.

```
SET :ADD_DAY = ADD_DAYS(CURRENT_DATE, 1)
```

The host variable ADD_DAY is set with the value representing 2007-02-01.

- Assume that DATE is a host variable with the value July 27, 1965. Set the host variable ADD_DAY with the value of that day plus 3 days.

```
SET :ADD_DAY = ADD_DAYS(:DATE, 3)
```

The host variable ADD_DAY is set with the value representing the day plus 3 days, 1965-07-30.

- The ADD_DAYS function and datetime arithmetic can be used to achieve the same results. The following examples demonstrate this.

```
SET :DATEHV = DATE('2008-2-28') + 4 DAYS  
SET :DATEHV = ADD_DAYS('2008-2-28', 4)
```

In both cases, the host variable DATEHV is set with the value '2008-03-03'.

Now consider the same examples but with the date '2008-2-29' as the argument.

```
SET :DATEHV = DATE('2008-2-29') + 4 DAYS  
SET :DATEHV = ADD_DAYS('2008-2-29', 4)
```

In both cases, the host variable DATEHV is set with the value '2008-03-04'.

- Assume that DATE is a host variable with the value July 27, 1965. Set the host variable ADD_DAY with the value of that day minus 3 days.

```
SET :ADD_DAY = ADD_DAYS(:DATE, -3)
```

The host variable ADD_DAY is set to 1965-07-24; the value representing July 27, 1965 minus 3 days.

ADD_MONTHS scalar function

The ADD_MONTHS function returns a date that represents *expression* plus a specified number of months.

```
►► ADD_MONTHS( expression, numeric-expression ) ◄◄
```

The schema is SYSIBM.

expression

An expression that specifies the starting date. *expression* must return a value that is a date, timestamp, or a valid string representation of a date or timestamp. A string representation is a value that is a built-in character string data type or graphic string data type, that is not a LOB, and that has an actual length that is not greater than 255 bytes. A time zone in a string representation of a timestamp is ignored. For the valid formats of string representations of dates and timestamps, see [“String representations of datetime values” on page 120](#).

If *expression* is a `TIMESTAMP WITH TIME ZONE` value, *expression* is first cast to a `TIMESTAMP WITHOUT TIME ZONE` value with the same precision as *expression*. If *expression* is a string, *expression* is first cast to `DATE`.

numeric-expression

An expression that returns a value of any built-in numeric data type. The integer portion of *numeric-expression* specifies the number of months to add to the starting date specified by *expression*. A negative numeric value is allowed.

numeric-expression can also be a character string or graphic string data type. The string input is implicitly cast to a numeric value of `DECFLOAT(34)`.

If *expression* is a timestamp with a time zone value, or a valid string representation of a timestamp with a time zone value, the result is determined from the UTC representation of the datetime value.

If *expression* is a timestamp value the result is a `TIMESTAMP WITHOUT TIME ZONE` with the same precision as *expression*. Otherwise, the result is a `DATE` value.

The result can be null; if any argument is null, the result is the null value.

If *expression* is the last day of the month or if the resulting month has fewer days than the day component of *expression*, the result is the last day of the resulting month. Otherwise, the result has the same day component as *expression*. Any hours, minutes, seconds, or fractional seconds information included in *expression* is not changed by the function.

The result CCSID is the appropriate CCSID of the argument encoding scheme and the result subtype is the appropriate subtype of the CCSID.

Example 1: Assume today is January 31, 2007. Set the host variable `ADD_MONTH` with the last day of January plus 1 month.

```
SET :ADD_MONTH = ADD_MONTHS(LAST_DAY(CURRENT_DATE), 1);
```

The host variable `ADD_MONTH` is set with the value representing the end of February, 2007-02-28.

Example 2: Assume `DATE` is a host variable with the value July 27, 1965. Set the host variable `ADD_MONTH` with the value of that day plus 3 months.

```
SET :ADD_MONTH = ADD_MONTHS(:DATE,3);
```

The host variable `ADD_MONTH` is set with the value representing the day plus 3 months, 1965-10-27.

Example 3: It is possible to achieve similar results with the `ADD_MONTHS` function and date arithmetic. The following examples demonstrate the similarities and contrasts.

```
SET :DATEHV = DATE('2008-2-28') + 4 MONTHS;
```

```
SET :DATEHV = ADD_MONTHS('2008-2-28', 4);
```

In both cases, the host variable `DATEHV` is set with the value '2008-06-29'.

Now consider the same examples but with the date '2008-2-29' as the argument.

```
SET :DATEHV = DATE('2008-2-29') + 4 MONTHS;
```

The host variable `DATEHV` is set with the value '2008-06-29'.

```
SET :DATEHV = ADD_MONTHS('2008-2-29', 4);
```

The host variable DATEHV is set with the value '2008-06-30'.

In this case, the ADD_MONTHS function returns the last day of the month, which is June 30, 2008, instead of June 29, 2008. The reason is that February 29 is the last day of the month. So, the ADD_MONTHS function returns the last day of June.

Example 4: Assume TSZ is an SQL variable with the timestamp with time zone value 2008-02-29.20.00.00.000000-08.00. Set TIMESZ to the value of that timestamp with time zone value plus 4 months.

```
SET TIMESZ: = ADD_MONTHS(TIMESTAMP_TZ(TSZ), 4);
```

The function returns a timestamp value that represents the timestamp plus 4 months: 2008-06-30-20.00.00.000000-8.00. The result of the ADD_MONTHS function does not contain a time zone.

Example 5: Assume TSZ is a host variable with the value '2008-02-29-20.00.000000-08.00', which is a string representation of a timestamp with a time zone value. Set TIMESZ to the value of that timestamp with a time zone plus 4 months.

```
SET TIMESZ: = ADD_MONTHS(:TSZ, 4);
```

With the string representation of a timestamp as input, the ADD_MONTHS function returns a DATE value that represents the timestamp plus 4 months, 2008-06-30. The host variable TIMESZ is set with the value that represents the timestamp with time zone plus 4 months.

ARRAY_DELETE scalar function

The ARRAY_DELETE function deletes elements from an array.

```
➔ ARRAY_DELETE( array-expression , , array-index1 , array-index2 ) ➔
```

The schema is SYSIBM.

array-expression

An SQL variable, SQL parameter, or global variable of an array type, or a CAST specification that specifies an SQL variable, SQL parameter, global variable, or parameter marker as the source value.

array-index1

An expression that results in a value that is castable to the data type of the array index. If *array-expression* is an ordinary array, *array-index1* must be the null value.

array-index2

An expression that results in a value that is castable to the data type of the array index. If *array-expression* is an ordinary array, *array-index2* must be the null value. If *array-index2* is specified and is a non-null value, *array-index1* must be a non-null value that is less than the value of *array-index2*. If *array-index2* is the null value, ARRAY_DELETE is evaluated as if *array-index2* was not specified.

The result of ARRAY_DELETE has the same data type as *array-expression*.

If *array-index1* and *array-index2* are not specified, or they are the null value, all of the elements of *array-expression* are deleted, and the cardinality of the result array value is 0. If only *array-index1* is specified with a non-null value, the array element at index value *array-index1* is deleted. If *array-index2* is specified with a non-null value, the elements ranging from index value *array-index1* to *array-index2*, inclusive, are deleted.

The result can be null; if the first argument is null, the result is the null value.

The ARRAY_DELETE function can be invoked only in the following contexts:

- A source value for SET *assignment-statement*, an SQL PL *assignment-statement*, or a VALUES INTO statement
- The value that is returned in a RETURN statement in an SQL scalar function

Notes

Syntax alternatives

CAST (SQL-variable AS array-type) can be specified as an alternative to SQL-variable. CAST (SQL-parameter AS array-type) can be specified as an alternative to SQL-parameter.

Examples

Example 1: Suppose that ordinary array variable RECENT_CALLS has the array type PHONENUMBERS. Use ARRAY_DELETE to delete all the elements from RECENT_CALLS. Assign the result to the RECENT_CALLS array.

```
SET RECENT_CALLS = ARRAY_DELETE(RECENT_CALLS);
```

After the SET statement is executed, RECENT_CALLS is an empty array, which has a cardinality of zero.

An equivalent way of setting RECENT_CALLS to an empty array is to use an array constructor:

```
SET RECENT_CALLS = ARRAY[ ];
```

Example 2: Suppose that PRODUCTS is defined as an associative array type with VARCHAR values for the array index, and that variables FLOOR_TILES and REMAINING_TILES are defined as arrays of the PRODUCTS array type. Use ARRAY_DELETE to assign the elements from the FLOOR_TILES array variable that do not have an index value between 'PK5100' and 'PS2500', inclusive, to the REMAINING_TILES array variable.

```
SET REMAINING_TILES = ARRAY_DELETE(FLOOR_TILES, 'PK5100', 'PS2500');
```

ARRAY_FIRST scalar function

The ARRAY_FIRST function returns the minimum array index value of an array.

►► ARRAY_FIRST(*array-expression*) ◄◄

The schema is SYSIBM.

array-expression

An SQL variable, SQL parameter, or global variable of an array type, or a CAST specification that specifies an SQL variable, SQL parameter, global variable, or parameter marker as the source value.

The result of ARRAY_FIRST has the same data type as the array index. If *array-expression* is not null, and the array is not empty (the cardinality of the array is greater than 0), the value of the result is the minimum array index value, which is 1 for an ordinary array.

The result can be null; if the argument is null, the result is the null value.

If the array is empty (the cardinality of the array is 0), the result is the null value.

Notes

Syntax alternatives:

CAST (SQL-variable AS array-type) can be specified as an alternative to SQL-variable. CAST (SQL-parameter AS array-type) can be specified as an alternative to SQL-parameter.

Example 1: Suppose that SPECIALNUMBERS is an ordinary array variable, and the elements of the array are integers. Return the first index value in the array variable SPECIALNUMBERS to the SQL variable E_CONSTIDX.

```
SET E_CONSTIDX = ARRAY_FIRST(SPECIALNUMBERS);
```

The result is 1.

Example 2: Suppose that PHONELIST is an associative array variable with VARCHAR index values. Values have been assigned to the elements in the array with the following statements:

```
SET PHONELIST['Home'] = '4443051234';  
SET PHONELIST['Work'] = '4443052345';  
SET PHONELIST['Cell'] = '4447893456';
```

The order in which values are assigned to array elements in an associative array does not matter. The elements of an associative array are stored in the array variable in ascending order of the associated array index values. After the values have been assigned to the PHONELIST array variable using the SET *assignment-statement* statements, the elements in the array variable are ordered as follows:

Index value	Element value
Cell	4447893456
Home	4443051234
Work	4443052345

Assign the value of the first index in the array variable to the character string variable named X.

```
SET X = ARRAY_FIRST(PHONELIST);
```

The value of 'Cell' is assigned to X because 'Cell' is the index value of the first element in the array variable.

Assign the value of the array element with index X to the SQL variable NUMBER_TO_CALL.

```
SET NUMBER_TO_CALL = PHONELIST[X];
```

The assignment statement assigns the phone number '4447893456' to NUMBER_TO_CALL.

ARRAY_LAST scalar function

The ARRAY_LAST function returns the maximum array index value of an array.

```
►► ARRAY_LAST( array-expression ) ◄◄
```

The schema is SYSIBM.

array-expression

An SQL variable, SQL parameter, or global variable of an array type, or a CAST specification that specifies an SQL variable, SQL parameter, global variable, or parameter marker as the source value.

The result of ARRAY_LAST has the same data type as the array index, which is INTEGER for an ordinary array. If *array-expression* is not null, and the array is not empty (the cardinality of the array is greater than 0), the value of the result is the maximum array index value, which is the current cardinality of the array for an ordinary array.

The result can be null; if the argument is null, the result is the null value.

If the array is empty (the cardinality of the array is 0), the result is the null value.

Notes

Syntax alternatives:

`CAST (SQL-variable AS array-type)` can be specified as an alternative to `SQL-variable`. `CAST (SQL-parameter AS array-type)` can be specified as an alternative to `SQL-parameter`.

Example 1: Suppose that `SPECIALNUMBERS` is an ordinary array variable, and the elements of the array are integers. The cardinality of the array is 10. Return the last index value in the array variable `SPECIALNUMBERS` to the SQL variable `PI_CONSTIDX`.

```
SET PI_CONSTIDX = ARRAY_LAST(SPECIALNUMBERS);
```

The result is 10.

Example 2: Suppose that `PHONELIST` is an associative array variable with `VARCHAR` index values. Values have been assigned to the elements in the array with the following statements:

```
SET PHONELIST['Home'] = '4443051234';  
SET PHONELIST['Work'] = '4443052345';  
SET PHONELIST['Cell'] = '4447893456';
```

The order in which values are assigned to array elements in an associative array does not matter. The elements of an associative array are stored in the array variable in ascending order of the associated array index values. After the values have been assigned to the `PHONELIST` array variable using the `SET assignment-statement` statements, the elements in the array variable are ordered as follows:

Index value	Element value
Cell	4447893456
Home	4443051234
Work	4443052345

Assign the value of the maximum index in the array variable to the character string variable named `X`.

```
SET X = ARRAY_LAST(PHONELIST);
```

The value of 'Work' is assigned to `X` because 'Work' is the index value of the last element in the array variable.

Assign the value of the array element with index `X` to the SQL variable `NUMBER_TO_CALL`.

```
SET NUMBER_TO_CALL = PHONELIST[X];
```

The assignment statement assigns the phone number '4443052345' to `NUMBER_TO_CALL`.

ARRAY_NEXT scalar function

The `ARRAY_NEXT` function returns the next larger array index value for an array, relative to a specified array index argument.

```
►► ARRAY_NEXT( array-expression ,array-index ) ◄◄
```

The schema is `SYSIBM`.

array-expression

An SQL variable, SQL parameter, or global variable of an array type, or a `CAST` specification that specifies an SQL variable, SQL parameter, global variable, or parameter marker as the source value.

array-index

An expression that results in a value that is castable to the data type of the array index. Valid values include any valid value for the data type.

array-index must *not* be an expression that references any of the following items:

- The CURRENT DATE, CURRENT TIME, or CURRENT TIMESTAMP special register
- A nondeterministic function
- A function that is defined with EXTERNAL ACTION
- A function that is defined with MODIFIES SQL DATA
- A sequence expression

The result of ARRAY_NEXT is the next larger array index value defined in the array, relative to the specified *array-index* value. If *array-index* is less than the minimum index array value in the array, the result is the first array index value that is defined in the array.

The data type of the result has the same data type as the array index.

The result is null under the following conditions:

- *array-expression* or *array-index* is null
- The array that is represented by *array-expression* is empty (the cardinality of the array is 0)
- The value of *array-index* is greater than or equal to the value of the last index in the array

Notes

Syntax alternatives:

CAST (*SQL-variable AS array-type*) can be specified as an alternative to *SQL-variable*. CAST (*SQL-parameter AS array-type*) can be specified as an alternative to *SQL-parameter*.

Example 1: Suppose that SPECIALNUMBERS is an ordinary array variable, and the elements of the array are integers. The cardinality of SPECIALNUMBERS is 10. Set the NEXT_CONSTIDX variable to the value of the array index for the SPECIALNUMBERS array element that follows the array element that is associated with an array index value of 9.

```
SET NEXT_CONSTIDX = ARRAY_NEXT(SPECIALNUMBERS,9);
```

The result is 10.

Example 2: Suppose that PHONELIST is an associative array variable with VARCHAR index values. Values have been assigned to the elements in the array with the following statements:

```
SET PHONELIST['Home'] = '4443051234';  
SET PHONELIST['Work'] = '4443052345';  
SET PHONELIST['Cell'] = '4447893456';
```

The order in which values are assigned to array elements in an associative array does not matter. The elements of an associative array are stored in the array variable in ascending order of the associated array index values. After the values have been assigned to the PHONELIST array variable using the SET *assignment-statement* statements, the elements in the array variable are ordered as follows:

Index

value Element value

Cell 4447893456

Home 4443051234

Work 4443052345

Assign the array index value that follows an array index value named 'Fax' to the character string variable named X.

```
SET X = ARRAY_NEXT(PHONELIST, 'Fax');
```

Array index value 'Fax' does not exist, but the string 'Home' follows the string 'Fax' in sorting order. Therefore, 'Home' is assigned to X.

Assign the value of the array element with index X to the SQL variable NUMBER_TO_CALL.

```
SET NUMBER_TO_CALL = PHONELIST[X];
```

Because the value of X is 'Home', the assignment statement assigns the phone number '4443051234' to NUMBER_TO_CALL.

ARRAY_PRIOR scalar function

The ARRAY_PRIOR function returns the next smaller array index value for an array, relative to a specified array index argument.

```
►► ARRAY_PRIOR( array-expression ,array-index ) ◄◄
```

The schema is SYSIBM.

array-expression

An SQL variable, SQL parameter, or global variable of an array type, or a CAST specification that specifies an SQL variable, SQL parameter, global variable, or parameter marker as the source value.

array-index

An expression that results in a value that is castable to the data type of the array index. Valid values include any valid value for the data type.

array-index must *not* be an expression that references any of the following items:

- The CURRENT DATE, CURRENT TIME, or CURRENT TIMESTAMP special register
- A nondeterministic function
- A function that is defined with EXTERNAL ACTION
- A function that is defined with MODIFIES SQL DATA
- A sequence expression

The result of ARRAY_PRIOR is the next smaller array index value that is defined in the array, relative to the specified *array-index* value. If *array-index* is greater than the maximum index array value in the array, the result is the last array index value that is defined in the array.

The data type of the result has the same data type as the array index.

The result is null under the following conditions:

- *array-expression* or *array-index* is null.
- The array that is represented by *array-expression* is empty (the cardinality of the array is 0).
- The value of *array-index* is less than or equal to the value of the first index in the array.

Notes

Syntax alternatives:

CAST (*SQL-variable* AS *array-type*) can be specified as an alternative to *SQL-variable*. CAST (*SQL-parameter* AS *array-type*) can be specified as an alternative to *SQL-parameter*.

Example 1: Suppose that SPECIALNUMBERS is an ordinary array variable, and the elements of the array are integers. The cardinality of SPECIALNUMBERS is 10. Set the PREV_CONSTIDX variable to the value of the array index for the SPECIALNUMBERS array element that precedes the array element that is associated with an array index value of 2.

```
SET PREV_CONSTIDX = ARRAY_PRIOR(SPECIALNUMBERS,2);
```

The result is 1.

Example 2: Suppose that PHONELIST is an associative array variable with VARCHAR index values. Values have been assigned to the elements in the array with the following statements:

```
SET PHONELIST['Home'] = '4443051234';  
SET PHONELIST['Work'] = '4443052345';  
SET PHONELIST['Cell'] = '4447893456';
```

The order in which values are assigned to array elements in an associative array does not matter. The elements of an associative array are stored in the array variable in ascending order of the associated array index values. After the values have been assigned to the PHONELIST array variable using the SET *assignment-statement* statements, the elements in the array variable are ordered as follows:

Index value	Element value
Cell	4447893456
Home	4443051234
Work	4443052345

Assign the array index value that precedes an array index value named 'Fax' to the character string variable named X.

```
SET X = ARRAY_PRIOR(PHONELIST, 'Fax');
```

Array index value 'Fax' does not exist, but the string 'Cell' precedes the string 'Fax' in sorting order. Therefore, 'Cell' is assigned to X.

Assign the array index value that precedes array index value 'Cell' to the character string variable named X.

```
SET X = ARRAY_PRIOR(PHONELIST, 'Cell');
```

The null value is assigned to X, because there is no array element before the array element with the index value 'Cell'.

ARRAY_TRIM scalar function

The ARRAY_TRIM function deletes elements from the end of an ordinary array.

►► ARRAY_TRIM — (*array-expression* , *numeric-expression*) ►◄

The ARRAY_TRIM function is identical to the TRIM_ARRAY function. For more information, see [“TRIM_ARRAY scalar function”](#) on page 605.

ASCII scalar function

The ASCII function returns the leftmost character of the argument as an integer.

```
►► ASCII(string-expression) ◄◄
```

The schema is SYSIBM.

The argument can be any built-in character or graphic string data type, except for CLOB or DBCLOB. If the argument is an EBCDIC, Unicode, or graphic string, it is first converted to an SBCS ASCII character string (CCSID 367)¹⁷ before the function is executed.

The argument can also be a numeric data type. The numeric argument is implicitly cast to a VARCHAR data type.

The result of the function is a large integer.

The result can be null; if the argument is null, the result is the null value.

Example: The following statement returns the ASCII value for the character 'A':

```
SET :hv = ASCII('A');
```

The host variable, :hv, is set to an integer with the value 65.

ASCII_CHR scalar function

The ASCII_CHR function returns the character that has the ASCII code value that is specified by the argument.

```
►► ASCII_CHR(expression) ◄◄
```

The schema is SYSIBM.

expression

An expression that returns a built-in data type of BIGINT, INTEGER, or SMALLINT.

expression can also be a character string or graphic string data type. The string input is implicitly cast to a numeric value of DECFLOAT(34) which is then assigned to a BIGINT value.

The result of the function is a fixed length character string encoded in the SBCS ASCII CCSID (regardless of the setting of the MIXED option in DSNHDECP). The length of the result is 1. If the value of *expression* is not in the range of 0 to 255, (0 to 127 if the SBCS ASCII CCSID for this system is CCSID 367) the null value is returned.

The result can be null; if the argument is null, the result is the null value.

Notes

Syntax alternatives:

CHR is a synonym for ASCII_CHR.

Examples

Example 1: Set :hv with the Euro symbol "€" in CCSID 923:

```
SET :hv = ASCII_CHR(164); -- x'A4'
```

¹⁷ If the conversion does not exist, the ASCII function will return an error, or a substitution character might be returned.

Set :hv with the Euro symbol "€" in CCSID 1252:

```
SET :hv = ASCII_CHR(128); -- x'80'
```

In both cases, the "€" is assigned to :hv, but because the Euro symbol is located at different code points for the two CCSIDs, the input value is different.

ASCII_STR or ASCIISTR scalar function

The ASCII_STR function returns an ASCII version of the string in the system ASCII CCSID. The system ASCII CCSID is the SBCS ASCII CCSID on a MIXED=NO system or the MIXED ASCII CCSID on a MIXED=YES system.

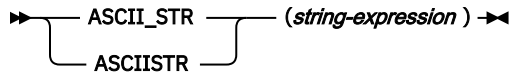

The schema is SYSIBM.

string-expression

An expression that returns a value of a built-in character or graphic string. A character string must not be bit data. *string-expression* must be an ASCII, EBCDIC, or Unicode string.

The argument can also be a numeric data type. The numeric argument is implicitly cast to a VARCHAR data type.

ASCII_STR returns an ASCII version of the string. If the system ASCII CCSID does not support the backslash (\) character, *string-expression* must not contain Non-ASCII characters. Non-ASCII characters are converted to UTF-16 characters and appear in the result in the form \xxxx (or \xxxx\yyyy for surrogate characters), where xxxx and yyyy represent a UTF-16 code unit.

The length attribute of the result will be $\text{MIN}(\text{MIN}(5 \times n), 32704)$. Where n is the result of applying the formulas in [Table 37 on page 163](#) based on input and output data types.

The result of the function is a varying-length character string in the system ASCII CCSID. If the actual length of the result string exceeds the maximum for the return type, an error occurs.

The result can be null; if the argument is null, the result is the null value.

Example

The following example returns the ASCII string equivalent of the Unicode (UTF-8) string, '4869206D616D6520697320D090D0BDD0B4D180D0B5D0B9202020F0908080':

```
SET :HV1 =  
ASCII_STR(X'48692C206D79206E616D6520697320D090D0BDD0B4D180D0B5D0B9202020F0908080');
```

:HV1 is assigned the value 'Hi, my name is \0410\043D\0434\0440\0435\0439 \D800\DC00'. In this example, the UTF-8 characters D090, D0BD, D0B4, D180, D0B5, and D0B9 are converted to \0410\043D\0434\0440\0435\0439 and the non-ASCII character F0908080 is converted to \D800\DC00.

```
SET :HV1 = ASCII_STR('Hi, my name is Андрей (Andrei)');
```

:HV1 is assigned the value "Hi, my name is \0410\043D\0434\0440\0435\0439 (Andrei)"

ASIN scalar function

The ASIN function returns the arc sine of the argument as an angle, expressed in radians. The ASIN and SIN functions are inverse operations.

►► ASIN(*numeric-expression*) ◄◄

The schema is SYSIBM.

The argument must be an expression that returns the value of any built-in numeric data type except for DECFLOAT. The value must be greater than or equal to -1 and less than or equal to 1. If the argument is not a double precision floating-point number, it is converted to one for processing by the function.

The result of the function is a double precision floating-point number.

The result can be null; if the argument is null, the result is the null value.

The result is greater than or equal to $-\pi/2$ and less than or equal to $\pi/2$.

Example: Assume that host variable ASINE is DECIMAL(10,9) with a value of 0.997494987. The following statement:

```
SELECT ASIN(:ASINE)
FROM SYSIBM.SYSDUMMY1;
```

returns a double precision floating-point number with an approximate value of 1.50.

ATAN scalar function

The ATAN function returns the arc tangent of the argument as an angle, expressed in radians. The ATAN and TAN functions are inverse operations.

►► ATAN(*numeric-expression*) ◄◄

The schema is SYSIBM.

The argument must be an expression that returns the value of any built-in numeric data type that is not DECFLOAT. The value must be greater than or equal to -1 and less than or equal to 1. If the argument is not a double precision floating-point number, it is converted to one for processing by the function.

The result of the function is a double precision floating-point number.

The result can be null; if the argument is null, the result is the null value.

The result is greater than or equal to $-\pi/2$ and less than or equal to $\pi/2$.

Example: Assume that host variable ATANGENT is DECIMAL(10,9) with a value of 14.10141995. The following statement returns a double precision floating-point number with an approximate value of 1.50:

```
SELECT ATAN(:ATANGENT)
FROM SYSIBM.SYSDUMMY1;
```

ATANH scalar function

The ATANH function returns the hyperbolic arc tangent of a number, expressed in radians. The ATANH and TANH functions are inverse operations.

►► ATANH(*numeric-expression*) ◄◄

The schema is SYSIBM.

The argument must be an expression that returns the value of any built-in numeric data type that is not DECFLOAT. The value must be greater than -1 and less than 1. If the argument is not a double precision floating-point number, it is converted to one for processing by the function.

The result of the function is a double precision floating-point number.

The result can be null; if the argument is null, the result is the null value.

Example: Assume that host variable HATAN is DECIMAL(10,9) with a value of 0.905148254. The following statement returns a double precision floating-point number with an approximate value of 1.50:

```
SELECT ATANH(:HATAN)
FROM SYSIBM.SYSDUMMY1;
```

ATAN2 scalar function

The ATAN2 function returns the arc tangent of x and y coordinates as an angle, expressed in radians.

►► ATAN2(*numeric-expression-1* ,*numeric-expression-2*) ◄◄

The schema is SYSIBM.

The first and second arguments specify the x and y coordinates, respectively.

Each argument must be an expression that returns the value of any built-in numeric data type that is not DECFLOAT. Both arguments must not be 0. Any argument that is not a double precision floating-point number is converted to one for processing by the function.

The result of the function is a double precision floating-point number.

The result can be null; if any argument is null, the result is the null value.

Example: Assume that host variables HATAN2A and HATAN2B are DOUBLE host variables with values of 1 and 2, respectively. The following statement returns a double precision floating-point number with an approximate value of 1.1071487:

```
SELECT ATAN2(:HATAN2A, :HATAN2B)
FROM SYSIBM.SYSDUMMY1;
```

BIGINT scalar function

The BIGINT function returns a big integer representation of either a number or a character or graphic string representation of a number.

Numeric to Big Integer:

►► BIGINT(*numeric-expression*) ◄◄

String to Big Integer:

►► BIGINT(*string-expression*) ◄◄

The schema is SYSIBM.

Numeric to Big Integer

numeric-expression

An expression that returns a value of any built-in numeric data type.

The result is the same number that would occur if the argument were assigned to a big integer column or variable. If the whole part of the argument is not within the range of big integers, an error is returned. The fractional part of the argument is truncated.

String to Big Integer

string-expression

An expression that returns a value of a character or graphic string (except a CLOB and DBCLOB) with a length attribute that is not greater than 255 bytes. The string must contain a valid string representation of a number.

The result is the same number that would result from `CAST(string-expression AS BIGINT)`. Leading and trailing blanks are eliminated and the resulting string must conform to the rules for forming an integer constant. If the whole part of the argument is not within the range of big integers, an error is returned.

The result of the function is a big integer.

The result can be null; if the argument is null, the result is the null value.

To increase the portability of applications, use the CAST specification.

Example 1: The following function returns the number 12345 (a BIGINT) for the number 12345.6:

```
SELECT BIGINT(12345.6)
FROM SYSIBM.SYSDUMMY1;
```

Example 2: The following function returns a BIGINT value of 123456789012 for the number 00123456789012.

```
SELECT BIGINT('00123456789012')
FROM SYSIBM.SYSDUMMY1;
```

Related reference

CAST specification

The CAST specification returns the first operand (the cast operand) converted to the data type that is specified by *data-type*.

BINARY scalar function

The BINARY function returns a BINARY (fixed-length binary string) representation of a string of any type or of a row ID type.

►► BINARY(*string-expression* , *integer*) ◀◀

The schema is SYSIBM.

string-expression

An expression that returns a value that is a built-in character string, graphic string, binary string, or a row ID type.

integer

An integer value that specifies the length attribute of the resulting binary string. The value must be an integer in the range 1–255 inclusive.

If *integer* is not specified:

- If the *string-expression* is the empty string constant, an error occurs
- Otherwise, the length attribute of the result is the same as the length attribute of *string-expression*, except when the input is graphic data. In this case, the length attribute of the result is twice the length of *string-expression*.

The result of the function is a fixed-length binary string.

The result can be null; if the first argument is null, the result is the null value.

The actual length is the same as the length attribute of the result. If the length of the *string-expression* is less than the length of the result, the result is padded with hexadecimal zeroes up to the length of the result. If the length of the *string-expression* is greater than the length attribute of the result, truncation is performed. A warning is returned unless the first input argument is a character string and all the truncated characters are blanks, or the first input argument is a graphic string and all the truncated characters are double-byte blanks, or the first input argument is a binary string and all the truncated bytes are hexadecimal zeroes.

Following examples assume EBCDIC encoding of the input string constants.

Example 1: The following function returns a fixed-length binary string with a length attribute 1 and a value BX'00'.

```
SELECT BINARY(' ',1)
FROM SYSIBM.SYSDUMMY1;
```

Example 2: The following function returns a fixed-length binary string with a length attribute 5 and a value BX'D2C2C80000'.

```
SELECT BINARY('KBH',5)
FROM SYSIBM.SYSDUMMY1;
```

Example 3: The following function returns a fixed-length binary string with a length attribute 3 and a value BX'D2C2C8'.

```
SELECT BINARY('KBH')
FROM SYSIBM.SYSDUMMY1;
```

Example 4: The following function returns a fixed-length binary string with a length attribute 3 and a value BX'D2C2C8'.

```
SELECT BINARY('KBH ',3)
FROM SYSIBM.SYSDUMMY1;
```

Example 5: The following function returns a fixed-length binary string with a length attribute 3 and a value BX'D2C2C8', a warning is also returned.

```
SELECT BINARY('KBH 93',3)
FROM SYSIBM.SYSDUMMY1;
```

Example 6: The following function returns a fixed-length binary string with a length attribute 3 and a value BX'C1C2C3', a warning is also returned.

```
SELECT BINARY(BINARY('ABC',5),3)
FROM SYSIBM.SYSDUMMY1;
```

BITAND, BITANDNOT, BITOR, BITXOR, and BITNOT scalar functions

The bit manipulation functions operate on the *twos complement* representation of the integer value of the input arguments. The functions return the result as a corresponding base 10 integer value in a data type that is based on the data type of the input arguments.

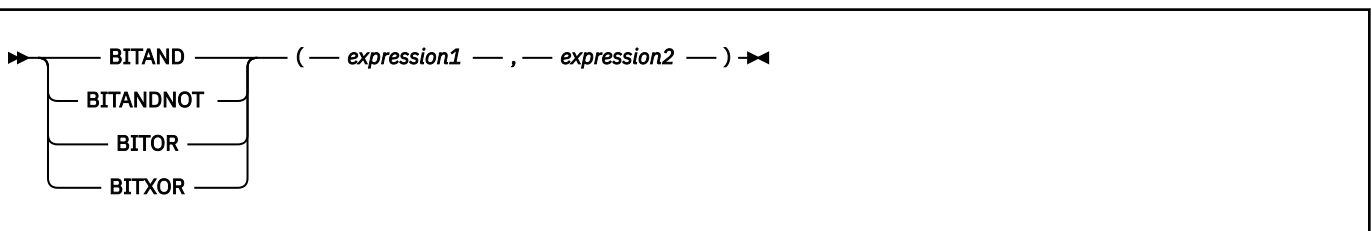

►► BITNOT — (— *expression* —) —►►

The schema is SYSIBM.

Table 67. The bit manipulation functions

Function	Description	The bit in the <i>twos complement</i> representation of the result
BITAND	Performs a bitwise AND operation.	1 - only if the corresponding bits in both arguments are 1.
BITANDNOT	Clears any bit in the first argument that is in the second argument.	0 - if the corresponding bit in the second argument is 1. copied from the corresponding bit in the first argument - if the corresponding bit in the first argument is not 1.
BITOR	Performs a bitwise OR operation.	1 - unless the corresponding bits in both arguments are 0.
BITXOR	Performs a bitwise exclusive OR operation.	1 - unless the corresponding bits in both arguments are the same.
BITNOT	Performs a bitwise NOT operation.	Opposite of the corresponding bit in the argument.

expression, expression1, or expression2

expression, expression1, or expression2 must be integer values represented by the data types SMALLINT, INTEGER, BIGINT, or DECFLOAT. Arguments that are of type DECIMAL, REAL, or DOUBLE are cast to DECFLOAT. The value is truncated to a whole number.

The bit manipulation functions can operate on up to 16 bits for SMALLINT, 32 bits for INTEGER, 64 bits for BIGINT, and 113 bits for DECFLOAT. The range of supported DECFLOAT values includes integers from -2^{122} to $2^{122} - 1$. Special values such as NaN or INFINITY are not supported.

If the two arguments have different data types, the argument that supports fewer bits is cast to a value with the data type of the argument that supports more bits. This cast impacts the bits that are set for negative values. For example, -1 as a SMALLINT value has 16 bits set to 1. When -1 is cast to an INTEGER value, it has 32 bits set to 1.

The result of the functions with two arguments has the data type of the argument that is highest in the data type precedence list for promotion. If either argument is DECFLOAT, the data type of the result is DECFLOAT(34).

The result of the BITNOT function has the same data type as the input argument, except that DECIMAL, REAL, DOUBLE, or DECFLOAT(16) returns DECFLOAT(34).

The result can be null; if any argument is null, the result is the null value.

Due to differences in internal representation between data types and on different hardware platforms, using functions (such as HEX) or host language constructs to view or compare internal representations of BIT function results and arguments is data type-dependent and not portable. The data type- and platform-independent way to view or compare BIT function results and arguments is to use the actual integer values.

The BITXOR function is can be used to toggle bits in a value.

The BITANDNOT function can be used to clear bits.

BITANDNOT(*val, pattern*) operates more efficiently than BITAND(*val, BITNOT(pattern)*).

The following examples are based on an ITEM table with a PROPERTIES column of type INTEGER.

Return all items for which the third property bit is set.

```
SELECT ITEMID FROM ITEM
WHERE BITAND(PROPERTIES, 4) = 4;
```

Return all items for which the fourth or the sixth property bit is set.

```
SELECT ITEMID FROM ITEM
WHERE BITAND(PROPERTIES, 40) <> 0;
```

Clear the twelfth property of the item whose ID is 3412.

```
UPDATE ITEM
SET PROPERTIES = BITANDNOT(PROPERTIES, 2048)
WHERE ITEMID = 3412;
```

Set the fifth property of the item whose ID is 3412.

```
UPDATE ITEM
SET PROPERTIES = BITOR(PROPERTIES, 16)
WHERE ITEMID = 3412;
```

Toggle the eleventh property of the item whose ID is 3412.

```
UPDATE ITEM
SET PROPERTIES = BITXOR(PROPERTIES, 1024)
WHERE ITEMID = 3412;
```

Switch all the bits in a 16-bit value that has only the second bit on.

```
SELECT BITNOT(CAST(2 AS SMALLINT))
FROM SYSIBM.SYSDUMMY1;
```

This example returns -3 (with a data type of SMALLINT).

BLOB scalar function

The BLOB function returns a BLOB representation of a string of any type or of a row ID type.

►► BLOB(*string-expression* , *integer*) ◄◄

The schema is SYSIBM.

string-expression

An expression that returns a value that is a built-in character string, graphic string, binary string, or a row ID type.

integer

An integer value that specifies the length attribute of the resulting binary string. The value must be an integer between 1 and the maximum length of a BLOB.

Do not specify *integer* if *string-expression* is a row ID type.

If you do not specify *integer* and *string-expression* is an empty string constant, the length attribute of the result is 1, and the result is an empty string. Otherwise, the length attribute of the result is the same as the length attribute of *string-expression*, except when the input is graphic data. In this case, the length attribute of the result is twice the length of *expression*.

The result of the function is a BLOB.

The result can be null; if the first argument is null, the result is the null value.

The actual length of the result is the minimum of the length attribute of the result and the actual length of *string-expression* (or twice the length of *string-expression* when the input is graphic data). If the length of *string-expression* is greater than the length attribute of the result, truncation is performed. A warning is returned unless the first input argument is a character string and all the truncated characters are blanks, or the first input argument is a graphic string and all the truncated characters are double-byte blanks.

Example 1: The following function returns a BLOB for the string 'This is a BLOB'.

```
SELECT BLOB('This is a BLOB')
FROM SYSIBM.SYSDUMMY1;
```

Example 2: The following function returns a BLOB for the large object that is identified by locator *myclob_locator*.

```
SELECT BLOB(:myclob_locator)
FROM SYSIBM.SYSDUMMY1;
```

Example 3: Assume that a table has a BLOB column named *TOPOGRAPHIC_MAP* and a VARCHAR column named *MAP_NAME*. Locate any maps that contain the string 'Engles Island' and return a single binary string with the map name concatenated in front of the actual map.

```
SELECT BLOB(MAP_NAME || ' : ' ) || TOPOGRAPHIC_MAP
FROM ONTARIO_SERIES_4
WHERE TOPOGRAPHIC_MAP LIKE BLOB('%Engles Island%')
```

BTRIM scalar function

The BTRIM function removes the characters that are specified in a trim string from the beginning and end of a source string.

FL 507

Passthrough-only expression: This function is passthrough-only and cannot run on Db2 for z/OS without acceleration. For information about invoking this function, see [Accelerating queries with passthrough-only expressions](#).

➤ BTRIM — (— *source-string* —————) ➤
 , — *trim-string* —

The schema is SYSIBM.

This function compares the binary representation of each character (consisting of one or more bytes) in the trim string to the binary representation of each character (consisting of one or more bytes) at the beginning and end of the source string. The database collation does not affect the search. If *source-string* is defined as FOR BIT DATA, the search compares each byte in *trim-string* to the byte at the beginning and end of *source-string*.

source-string

An expression that specifies the string from which characters are to be removed. This expression must return a built-in character string, graphic string, numeric value, or datetime value. If the source string is:

- A numeric or datetime value, it is implicitly cast to VARCHAR before the function is evaluated
- A CLOB value, the length of the value is limited to the maximum size of a VARCHAR
- A DBCLOB value, the actual length of the value is limited to the maximum size of a VARGRAPHIC

trim-string

An expression that specifies the characters that are to be removed from the beginning and end of the source string. The expression must return a built-in character string, graphic string, numeric value, or datetime value. If the trim string is:

- Not a character string or graphic string, it is implicitly cast to VARCHAR before the function is evaluated

- A CLOB, the actual length of the value is limited to the maximum size of a VARCHAR
- A DBCLOB, the actual length of the value is limited to the maximum size of a VARGRAPHIC

The type of the source string determines the default trim string:

Type of source string	Default trim string
A graphic string	double-byte blank
A FOR BIT DATA string	X'20'
All other cases	single-byte blank

Restrictions:

- If the source string is not defined as FOR BIT DATA, then the trim string cannot be defined as FOR BIT DATA.
- If one parameter (source string or trim string) is character FOR BIT DATA, then the other parameter cannot be a graphic.

Result

The data type of the source string determines the data type of the result:

Data type of source string	Data type of result
VARCHAR or CHAR	VARCHAR
CLOB	CLOB
VARGRAPHIC or GRAPHIC	VARGRAPHIC
DBCLOB	DBCLOB

The length attribute of the data type of the result is the same as the length attribute of the data type of the source string. The length of the result is the length of the source string minus the number of string units that were removed. If all of the characters are removed, the result is an empty string with a length of zero.

If any argument can be null, the result can be null. If any argument is null, the result is the null value.

Examples

- The host variable BALANCE1 is of type CHAR(9) and has the value ' 000345.50'. The following statement returns the value '345.5':

```
SELECT BTRIM(:BALANCE1, '0')
FROM SYSIBM.SYSDUMMY1
```

- The host variable BALANCE2 is of type CHAR(9) and has the value ' 345.50'. The following statement returns the value '345.50':

```
SELECT BTRIM(:BALANCE2)
FROM SYSIBM.SYSDUMMY1
```

CARDINALITY scalar function

The CARDINALITY function returns a value of type BIGINT that represents the number of elements of an array.

```
►► CARDINALITY( array-expression ) ◄◄
```

The schema is SYSIBM.

array-expression

An SQL variable, SQL parameter, or global variable of an array type, or a CAST specification that specifies an SQL variable, SQL parameter, global variable, or parameter marker as the source value.

The result of the CARDINALITY function is as follows:

- For an ordinary array, the result is the highest array index for which the array has an assigned element. Elements that have been assigned the null value are considered to be assigned elements.
- For an associative array, the result is the actual number of unique array index values that are defined in *array-expression*.
- For an empty array, the result is 0.

The data type of the result is BIGINT.

The result can be null; if *array-expression* is null, the result is the null value.

Example 1: Suppose that the array RECENT_CALLS is defined and contains a record of recent calls. RECENT_CALLS contains three elements. The following SET statement assigns the number of calls that have been stored in the array so far to SQL variable HOWMANYCALLS:

```
SET HOWMANYCALLS = CARDINALITY(RECENT_CALLS);
```

After the statement executes, HOWMANYCALLS contains 3.

Example 2: Suppose that the associative array variable CANADACAPITALS of array type CAPITALSARRAY contains all of the capitals for the 10 provinces and three territories in Canada, as well as the capital of the country, Ottawa. The following SET statement assigns the cardinality of CANADACAPITALS to SQL variable NUMCAPITALS.

```
SET NUMCAPITALS = CARDINALITY(CANADACAPITALS);
```

After the statement executes, CANADACAPITALS contains 14.

CCSID_ENCODING scalar function

The CCSID_ENCODING function returns a string value that indicates the encoding scheme of a CCSID that is specified by the argument.

```
►► CCSID_ENCODING( expression ) ◄◄
```

The schema is SYSIBM.

expression

expression must be an expression that returns a value of a built-in numeric, character, or graphic string data type that is not a LOB. A character string must not have a length attribute greater than 255, and a graphic string must not have a length attribute greater than 127. If *expression* is a character or graphic string, the string must contain a valid string representation of a number. Leading and trailing blanks are eliminated and the resulting string must conform to the rules for forming a numeric constant.

The function returns a value of ASCII, EBCDIC, UNICODE, or UNKNOWN depending on the CCSID specified by expression.

The result of the function is a fixed-length character string of length 8, which is padded on the right if necessary.

The result can be null; if the argument is null, the result is the null value.

The CCSID of the result is determined from the context in which the function was invoked. For more information, refer to [Determining the encoding scheme and CCSID of a string \(Introduction to Db2 for z/OS\)](#).

Example 1: The following function returns a CCSID with a value for EBCDIC data.

```
SELECT CCSID_ENCODING(37) AS CCSID
FROM SYSIBM.SYSDUMMY1;
```

Example 2: The following function returns a CCSID with a value for ASCII data.

```
SELECT CCSID_ENCODING(850) AS CCSID
FROM SYSIBM.SYSDUMMY1;
```

Example 3: The following function returns a CCSID with a value for Unicode data.

```
SELECT CCSID_ENCODING(1208) AS CCSID
FROM SYSIBM.SYSDUMMY1;
```

Example 4: The following function returns a CCSID with a value of UNKNOWN.

```
SELECT CCSID_ENCODING(1) AS CCSID
FROM SYSIBM.SYSDUMMY1;
```

Example 5: The following function returns a CCSID with a value for EBCDIC data. The input data is a character string.

```
SELECT CCSID_ENCODING('37') AS CCSID
FROM SYSIBM.SYSDUMMY1;
```

CEILING or CEIL scalar function

The CEILING function returns the smallest integer value that is greater than or equal to the argument.

```
▶▶ CEILING (numeric-expression) ▶▶
    |
    | CEIL
```

The schema is SYSIBM.

The argument must be an expression that returns a value of any built-in numeric data type.

The argument can also be a character string or graphic string data type. The string input is implicitly cast to a numeric value of DECFLOAT(34).

The result of the function has the same data type and length attribute as the argument except that the scale is 0 if the argument is DECIMAL. For example, an argument with a data type of DECIMAL(5,5) results in DECIMAL(5,0).

The result can be null; if the argument is null, the result is the null value.

Examples

Example 1

The following statement shows the use of CEILING on positive and negative values:

```
SELECT CEILING(3.5), CEILING(3.1), CEILING(-3.1), CEILING(-3.5)
FROM SYSIBM.SYSDUMMY1;
```

This example returns: 04., 04., -03., -03.

Example 2

Using sample table DSN8C10.EMP, find the highest monthly salary for all the employees. Round the result up to the next integer. The SALARY column has a decimal data type.

```
SELECT CEILING(MAX(SALARY)/12)
FROM DSN8C10.EMP;
```

This example returns 04396, because the highest paid employee is Christine Haas who earns \$52750.00 per year. Her average monthly salary before applying the CEILING function is 4395.83.

CHAR scalar function

The CHAR function returns a fixed-length character string representation of the argument.

The syntax of the CHAR function depends on the data type of the input argument. The following types of input arguments are accepted.

Integer to Character:

► CHAR(*integer-expression*) ◄

Decimal to Character:

► CHAR(*decimal-expression* , — *decimal-character*) ◄

Floating-Point to Character:

► CHAR(*floating-point-expression*) ◄

Decimal floating-point to Character:

► CHAR(*decimal-floating-point-expression*) ◄

Character to Character:

► CHAR(*character-expression* , — *integer* , — *CODEUNITS16* , — *CODEUNITS32* , — *OCTETS*) ◄

Graphic to Character:

► CHAR(*graphic-expression* , — *integer* , — *CODEUNITS16* , — *CODEUNITS32*) ◄

Datetime to Character:

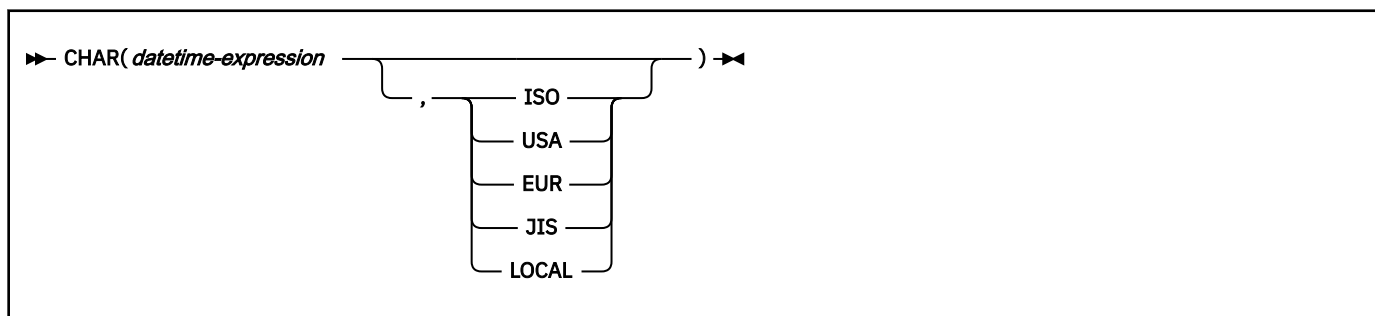

Row ID to Character:

►► CHAR(*row-ID-expression*) ◄◄

The schema is SYSIBM.

The CHAR function returns a fixed-length character string representation of one of the following values:

- An integer number if the first argument is a SMALLINT, INTEGER, or BIGINT
- A decimal number if the first argument is a decimal number
- A double-precision floating-point number if the first argument is a DOUBLE or REAL
- A decimal floating-point number if the first argument is a DECFLOAT
- A character string value if the first argument is any type of character string
- A graphic string if the first argument is an EBCDIC or Unicode graphic string
- A datetime value if the first argument is a date, time, or timestamp
- A row ID value if the first argument is a row ID

The result of the function is a fixed-length character string (CHAR).

The result can be null; if the first argument is null, the result is the null value.

Integer to Character

integer-expression

An expression that returns a value that is a built-in integer data type (SMALLINT, INTEGER, or BIGINT).

The result is the fixed-length character string representation of the argument in the form of an SQL integer constant. The result is the smallest number of characters that can be used to represent the value of the argument, padded with blanks. The result consists of *n* characters that are the significant digits that represent the value of the argument with a preceding minus sign if the argument is negative. A positive value starts with a digit and always includes at least one trailing blank. Leading zeroes are not included. The result is left justified:

- If the argument is a small integer, the length of the result is 6. If the number of characters in the result is less than 6, the result is padded on the right with blanks.
- If the argument is a large integer, the length of the result is 11; if the number of characters in the result is less than 11, the result is padded on the right with blanks.
- If the argument is a big integer, the length of the result is 20. If the number of characters in the result is less than 20, the result is padded on the right with blanks.

A positive value always includes one trailing blank.

The CCSID of the result is determined from the application encoding scheme.

Decimal to Character

decimal-expression

An expression that returns a value that is a built-in decimal data type. To specify a different precision and scale for the value of the expression, apply the DECIMAL function before applying the CHAR function.

decimal-character

Specifies the single-byte character constant that is used to delimit the decimal digits in the result character string. The character must not be a digit, a plus sign (+), a minus sign (-), or a blank. The default is the period (.) or comma (,). For information on what factors govern the choice, see [“Decimal point representation” on page 323](#).

The result is the fixed-length character string representation of the first argument. The result is the smallest number of characters that can be used to represent the value of the argument, except that trailing zeros are included.

The result includes a decimal character and up to p digits, where p is the precision of the *decimal-expression* with the preceding minus sign if the argument is negative. A positive value starts with a digit or the decimal character, and always includes at least one trailing blank. Leading zeros are not returned. If the scale of *decimal-expression* is zero, the decimal character is not returned. If the number of bytes in the result is less than the defined length of the result, the result is padded on the right with blanks.¹⁸

The length of the result is $2 + p$, where p is the precision of the *decimal-expression*.

The CCSID of the result is determined from the application encoding scheme.

Floating-Point to Character

floating-point-expression

An expression that returns a value that is a built-in floating-point data type (DOUBLE or REAL).

The result is the fixed-length character string representation of the argument in the form of an SQL floating-point constant. If the argument is negative, the first character of the result is a minus sign; otherwise, the first character is a digit. If the argument is zero, the result is 0E0.

The length of the result is 24. The result includes the smallest number of characters that can represent the value of the argument such that the mantissa consists of a single digit, other than zero, followed by a period and a sequence of digits.

If the number of characters in the result is less than 24, the result is padded on the right with blanks.

The CCSID of the result is determined from the application encoding scheme.

Decimal floating-point to Character

decimal-floating-point-expression

An expression that returns a value that is a built-in decimal floating-point data type (DECFLOAT).

The result is the fixed-length character string representation of the argument in the form of an SQL decimal floating-point constant.

If the result value is Infinity, sNaN, or NaN, the strings 'INFINITY', 'SNAN', and 'NAN', respectively, are returned. The DECFLOAT special value sNaN does not result in an exception when converted to a string.

The length of the result is 42. If the number of characters in the result is less than 42, the result is padded on the right with blanks. Trailing zeros are significant. If the argument is negative, the first character of the result is a minus sign. Otherwise, the first character is a digit, or a letter if the result value is Infinity, sNaN, or NaN.

The CCSID of the result is determined from the application encoding scheme.

¹⁸ If the function is invoked as CHAR and the BIF_COMPATIBILITY subsystem parameter is set to V9_DECIMAL_VARCHAR, or if the function is invoked as SYSCOMPAT_V9.CHAR, the result is formatted the same as the result of the [CHAR9](#) function.

Character to Character

character-expression

An expression that returns a value of a built-in character string.

integer

The length attribute for the resulting fixed-length character string. The value must be an integer constant in the range 1–255.

If the length is not specified, the length attribute of the result is the minimum of 255 and the length attribute of *character-expression*. If *character-expression* is an empty string constant, an error occurs.

If CODEUNITS16 or CODEUNITS32 is specified, see [“Determining the length attribute of the final result” on page 108](#) for information about how to calculate the length attribute of the result string.

CODEUNITS16, CODEUNITS32, or OCTETS

Specifies the unit that is used to express *integer*. If *character-expression* is a character string that is defined as bit data, CODEUNITS16 and CODEUNITS32 cannot be specified.

CODEUNITS16

Specifies that *integer* is expressed in terms of 16-bit UTF-16 code units.

CODEUNITS32

Specifies that *integer* is expressed in terms of 32-bit UTF-32 code units.

OCTETS

Specifies that *integer* is expressed in terms of bytes.

For more information about CODEUNITS16, CODEUNITS32, and OCTETS, see [“String unit specifications” on page 106](#).

The actual length is the same as the length attribute of the result. If the length of *character-expression* is less than the length attribute of the result, the result is padded with blanks to the length of the result. If the length of *character-expression* is greater than the length attribute of the result, the result is truncated. Unless all of the truncated characters are blanks, a warning is returned.

If *character-expression* is bit data, the result is bit data. Otherwise, the CCSID of the result is the same as the CCSID of *character-expression*.

Graphic to Character

graphic-expression

An expression that returns a value of a built-in graphic string.

integer

The length attribute for the resulting fixed-length character string. The value must be an integer constant in the range 1–255.

If the length is not specified, the length attribute of the result is the minimum of 255 and the length attribute of *graphic-expression*. The length attribute of *graphic-expression* is (3 * *length(graphic-expression)*). If *graphic-expression* is an empty string constant, an error occurs.

If CODEUNITS16 or CODEUNITS32 is specified, see [“Determining the length attribute of the final result” on page 108](#) for information about how to calculate the length attribute of the result string.

CODEUNITS16 or CODEUNITS32

Specifies the unit that is used to express *integer*.

CODEUNITS16

Specifies that *integer* is expressed in terms of 16-bit UTF-16 code units.

CODEUNITS32

Specifies that *integer* is expressed in terms of 32-bit UTF-32 code units.

For more information about CODEUNITS16 and CODEUNITS32, see [“String unit specifications” on page 106](#).

The actual length is the same as the length attribute of the result. If the length of *graphic-expression* is less than the length attribute of the result, the result is padded with blanks to the length of the result. If the length of *graphic-expression* is greater than the length attribute of the result, the result is truncated. Unless all of the truncated characters are blanks, a warning is returned.

The CCSID of the result is the character mixed CCSID that corresponds to the graphic CCSID of *graphic-expression*.

Datetime to Character

datetime-expression

An expression that is one of the following built-in data types:

date

The result is the character string representation of the date in the format that is specified by the second argument. If the second argument is omitted, the DATE precompiler option, if one is provided, otherwise field DATE FORMAT on installation panel DSNTIP4 specifies the format. If the format is LOCAL, field LOCAL DATE LENGTH on installation panel DSNTIP4 specifies the length of the result. Otherwise, the length of the result is 10.

LOCAL denotes the local format at the Db2 subsystem that executes the SQL statement. If LOCAL is used for the format, a date exit routine must be installed at that Db2 subsystem.

An error occurs if the second argument is specified and is not a valid value.

time

The result is the character string representation of the time in the format that is specified by the second argument. If the second argument is omitted, the TIME precompiler option, if one is provided, otherwise field TIME FORMAT on installation panel DSNTIP4 specifies the format. If the format is LOCAL, the field LOCAL TIME LENGTH on installation panel DSNTIP4 specifies the length of the result. Otherwise, the length of the result is 8.

LOCAL denotes the local format at the Db2 subsystem that executes the SQL statement. If LOCAL is used for the format, a time exit routine must be installed at that Db2 subsystem.

An error occurs if the second argument is specified and is not a valid value.

timestamp without time zone

The result is the character string representation of the timestamp. If *datetime-expression* is a `TIMESTAMP(0)` value, the length of the result is 19. If *datetime-expression* is a `TIMESTAMP(integer)` value, the length of the result is $20+integer$. Otherwise, the length of the result is 26. The second argument must not be specified.

timestamp with time zone

The result is the character string representation of the timestamp with time zone, formatted as `yyyy-mm-dd-hh.mm.ss.nnnnnn±th:tm` with the appropriate number of 'n' characters for the precision of the timestamp. If *datetime-expression* is a `TIMESTAMP(0) WITH TIME ZONE`, the length of the result is 147. If *datetime-expression* is a `TIMESTAMP(integer) WITH TIME ZONE`, the length of the result is $148+integer$. The second argument must not be specified.

The CCSID of the result is determined from the context in which the function is invoked. For more information, see [Determining the encoding scheme and CCSID of a string \(Introduction to Db2 for z/OS\)](#).

ISO, EUR, USA, JIS, or LOCAL

Specifies the date or time format of the resulting character string. For more information, see [“String representations of datetime values”](#) on page 120.

Row ID to Character

row-ID-expression

An expression that returns a value that is a built-in row ID data type.

The result is the fixed-length character string representation of the argument. The result is bit data.

The length of the result is 40. If the length of *row-ID-expression* is less than 40, the result is padded on the right with hexadecimal zeros to a length of 40.

Recommendation: To increase the portability of applications, use the CAST specification when the first argument is numeric, or the first argument is a string and the length argument is specified. For more information, see [“CAST specification” on page 267](#).

Notes

Syntax alternatives:

CHAR9 can be specified as an alternative to CHAR, except when the first argument is decimal data. See [CHAR9](#).

Examples

Example 1:

HIREDATE is a DATE column in sample table DSN8C10.EMP. When it represents the date 15 December 1976 (as it does for employee 140), the following example returns the string value '12/15/1976' in character string variable DATESTRING:

```
EXEC SQL SELECT CHAR(HIREDATE, USA)
INTO :DATESTRING
FROM DSN8C10.EMP
WHERE EMPNO = '000140';
```

Example 2:

Host variable *HOUR* has a data type of DECIMAL(6,0) and contains a value of 50000. Interpreted as a time duration, this value is 5 hours. Assume that STARTING is a TIME column in some table. Then, when STARTING represents 17 hours, 30 minutes, and 12 seconds after midnight, the following example returns the value '10:30 PM':

```
CHAR(STARTING+:HOURS, USA)
```

Example 3:

Assume that RECEIVED is defined as a TIMESTAMP column in table TABLEY. When the value of the date portion of RECEIVED represents the date 10 March 1997 and the time portion represents 6 hours and 15 seconds after midnight, the following example returns the string value '1997-03-10-06.00.15.000000':

```
SELECT CHAR(RECEIVED)
FROM TABLEY
WHERE INTCOL = 1234;
```

Example 4:

For sample table DSN8C10.EMP, the following SQL statement sets the host variable *AVERAGE*, which is defined as CHAR(33), to the character string representation of the average employee salary.

```
EXEC SQL SELECT CHAR(AVG(SALARY))
INTO :AVERAGE
FROM DSN8C10.EMP;
```

With DEC31, the result of AVG applied to a decimal number is a decimal number with a precision of 31 digits. The only host languages in which such a large decimal variable can be defined are Assembler and C. For host languages that do not support such large decimal numbers, use the method shown in this example.

Example 5:

For the rows in sample table DSN8C10.EMP, return the values in column LASTNAME, which is defined as VARCHAR(15), as a fixed-length character string and limit the length of the results to 10 characters.

```
SELECT CHAR(LASTNAME, 10)
FROM DSN8C10.EMP;
```

For rows that have a LASTNAME with a length greater than 10 characters (excluding trailing blanks), a warning that the value is truncated is returned.

Example 6:

FIRSTNAME is a VARCHAR(12) column in a Unicode table T1. One of its values is the 6-character string 'Jürgen'. When FIRSTNAME has the values shown under 'Function', the results are shown under 'Returns':

Function ...	Returns ...
CHAR(FIRSTNAME, 3, CODEUNITS32)	'Jür' -- x'4AC3BC7220202020202020'
CHAR(FIRSTNAME, 3, CODEUNITS16)	'Jür' -- x'4AC3BC722020202020'
CHAR(FIRSTNAME, 3, OCTETS)	'Jü' -- x'4AC3BC'

Example 7

For the rows in sample table DSN8C10.EMP, return the values in column EDLEVEL, which is defined as SMALLINT, as a fixed-length character string.

```
SELECT CHAR(EDLEVEL)
FROM DSN8C10.EMP;
```

An EDLEVEL of 18 is returned as CHAR(6) value '18 ' (18 followed by four blanks).

Example 8:

In sample table DSN8C10.EMP, the SALARY column is defined as DECIMAL(9,2). For those employees who have a salary of 52750.00, return the hire date and the salary, using a comma as the decimal character in the salary (52750,00).

```
SELECT HIREDATE, CHAR(SALARY, ',', ')
FROM DSN8C10.EMP
WHERE SALARY = 52750.00;
```

The salary is returned as the string value '52750,00'.

Example 9:

Repeat the scenario in Example 8 except subtract the SALARY column from 60000.00 and return the salary with the default decimal character.

```
SELECT HIREDATE, CHAR(60000.00 - SALARY)
FROM DSN8C10.EMP
WHERE SALARY = 52750.00;
```

The salary is returned as the string value '7250.00'.

Example 10:

Assume that host variable SEASONS_TICKETS is defined as INTEGER and has a value of 10000. Use the DECIMAL and CHAR functions to change the value into the character string '10000.00'.

```
SELECT CHAR(DECIMAL(:SEASONS_TICKETS, 7, 2))
FROM SYSIBM.SYSDUMMY1;
```

Example 11:

Assume that columns COL1 and COL2 in table T1 are both defined as REAL and that T1 contains a single row with the values 7.1E+1 and 7.2E+2 for the two columns. Add the two columns and represent the result as a character string.

```
SELECT CHAR(COL1 + COL2)
FROM T1;
```

The result is the character value '1.43E2 '.

Related concepts

[Data types of columns \(Introduction to Db2 for z/OS\)](#)

Related reference

[“CHAR9 scalar function” on page 412](#)

The CHAR9 function returns a fixed-length character string representation of the argument. The CHAR9 function is intended for compatibility with previous releases of Db2 for z/OS that depend on the result format that is returned for decimal input values in Version 9 and earlier.

[BIF COMPATIBILITY field \(BIF_COMPATIBILITY subsystem parameter\) \(Db2 Installation and Migration\)](#)

CHAR9 scalar function

The CHAR9 function returns a fixed-length character string representation of the argument. The CHAR9 function is intended for compatibility with previous releases of Db2 for z/OS that depend on the result format that is returned for decimal input values in Version 9 and earlier.

Important: For portable applications that might run on platforms other than Db2 for z/OS, use the [CHAR](#) function instead. Other Db2 family products do not support the CHAR9 function.

The first argument can be any one value of the following types:

- Integer number
- Decimal number
- Floating-point number
- Decimal floating-point number
- Character string
- Graphic string
- Datetime value
- Row ID value

If the first argument is a decimal number, the result is formatted as indicated in the following description. However, if the first argument is not a decimal number, the result is identical to the result of the CHAR function.

Decimal to Character:

```
CHAR9( decimal-expression , decimal-character )
```

Decimal to Character

decimal-expression

An expression that returns a value that is a built-in decimal data type. To specify a different precision and scale for the value of the expression, apply the DECIMAL function before applying the CHAR9 function.

decimal-character

Specifies the single-byte character constant (CHAR or VARCHAR) that delimits the decimal digits in the result character string. The character must not be a digit, a plus sign (+), a minus sign (-), or a blank. The default is the period (.) or comma (,). For information about the factors that govern the choice, see [“Decimal point representation” on page 323](#)

The result is the fixed-length character string representation of the argument. The result includes a decimal character and up to p digits, where p is the precision of the *decimal-expression* with the preceding minus sign if the argument is negative. Leading and trailing zeros are returned, and a leading blank is returned for a positive decimal value. The result includes a decimal character even if the scale of *decimal-expression* is zero. If the number of bytes in the result is less than the defined length of the result, the result is padded on the right with blanks.

The length of the result is $2 + p$, where p is the precision of the *decimal-expression*.

The length attribute of the result is 2+p where p is the precision of *decimal-expression*.

The actual length of the result is the smallest number of characters that can be used to represent the result, except that trailing zeros are included. If the argument is negative, the result begins with a minus sign. Otherwise, the result begins with a digit. If the scale of *decimal-expression* is zero, the decimal character is not returned.

The CCSID of the result is determined from the context in which the function was invoked. For more information, see [Determining the encoding scheme and CCSID of a string \(Introduction to Db2 for z/OS\)](#).

Examples

The following table shows the difference between the results of the CHAR and CHAR9 functions for example decimal number arguments.

Table 68. Example results of CHAR and CHAR9 functions

Decimal argument	CHAR function result	CHAR9 function result
(000.1)	' .1 '	' 000.1 '
(1000)	'1000 '	' 1000. '
(1.1)	'1.1 '	' 1.1 '

Related concepts

[Data types of columns \(Introduction to Db2 for z/OS\)](#)

Related reference

[CHAR scalar function](#)

The CHAR function returns a fixed-length character string representation of the argument.

[BIF COMPATIBILITY field \(BIF_COMPATIBILITY subsystem parameter\) \(Db2 Installation and Migration\)](#)

CHARACTER_LENGTH or CHAR_LENGTH scalar function

The CHARACTER_LENGTH function returns the length of the first argument in the specified string unit.

[FL 506](#)

Character string:

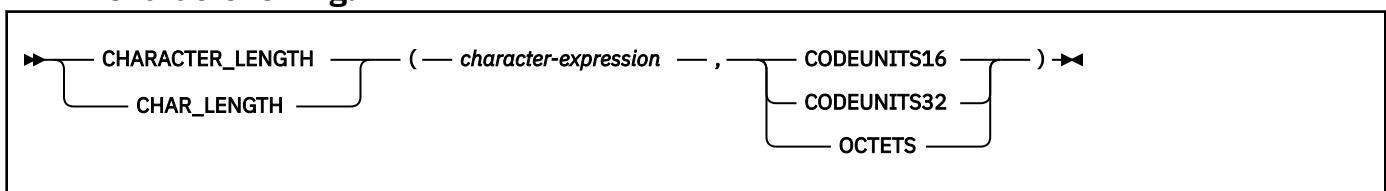

Graphic string:

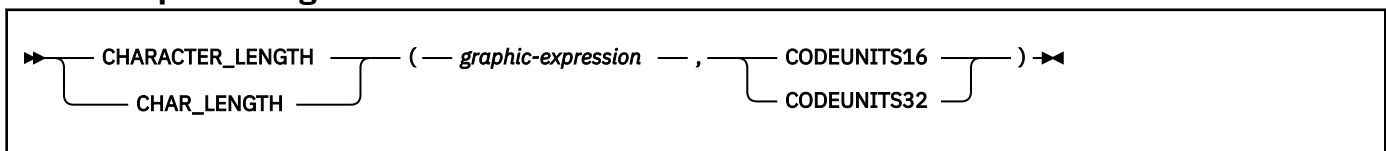

The schema is SYSIBM.

Character string:

character-expression

An expression that returns a value of a built-in character string. *character-expression* cannot be bit data.

The argument can also be a numeric data type. The numeric argument is implicitly cast to a VARCHAR data type.

CODEUNITS16, CODEUNITS32, or OCTETS

Specifies the unit that is used to express the length of the result.

CODEUNITS16

Specifies that the result is expressed in terms of 16-bit UTF-16 code units.

CODEUNITS32

Specifies that the result is expressed in terms of 32-bit UTF-32 code units.

OCTETS

Specifies the result is expressed in terms of bytes.

For more information about CODEUNITS16, CODEUNITS32, and OCTETS, see [“String unit specifications” on page 106](#).

The result of the function is a large integer.

The result can be null; if the argument is null, the result is the null value.

The result is the length of *character-expression* expressed in the number of string units that were specified. The length of fixed-length strings includes trailing blanks. The length of varying-length strings is the actual length and not the maximum length.

Graphic string:

graphic-expression

An expression that returns a value of a built-in graphic string.

The argument can also be a numeric data type. The numeric argument is implicitly cast to a VARCHAR data type.

CODEUNITS16 or CODEUNITS32

Specifies the unit that is used to express the length of the result.

CODEUNITS16

Specifies that the result is expressed in terms of 16-bit UTF-16 code units.

CODEUNITS32

Specifies that the result is expressed in terms of 32-bit UTF-32 code units.

For more information about CODEUNITS16 and CODEUNITS32 see [“String unit specifications” on page 106](#).

The result of the function is a large integer.

The result can be null; if the argument is null, the result is the null value.

The result is the length of *graphic-expression* expressed in the number of string units that were specified. The length of fixed-length strings includes trailing blanks. The length of varying-length strings is the actual length and not the maximum length.

Example: Assume that NAME is a VARCHAR(128) column, encoded in Unicode UTF-8, that contains the value 'Jürgen'. The following two queries return the value 6:

```
SELECT CHARACTER_LENGTH(NAME, CODEUNITS32)
FROM T1 WHERE NAME = 'Jürgen';
SELECT CHARACTER_LENGTH(NAME, CODEUNITS16)
FROM T1 WHERE NAME = 'Jürgen';
```

The following two queries return the value 7:

```
SELECT CHARACTER_LENGTH(NAME, OCTETS)
FROM T1 WHERE NAME = 'Jürgen';
SELECT LENGTH(NAME)
FROM T1 WHERE NAME = 'Jürgen';
```

CHR scalar function

The CHR function returns the character that has the ASCII code value that is specified by the argument.

►► CHR(*expression*) ◄◄

The CHR function is identical to the ASCII CHR function. For more information, see [“ASCII CHR scalar function”](#) on page 393.

CLOB scalar function

The CLOB function returns a CLOB representation of a string.

Character to CLOB:

►► CLOB(*character-expression* , *integer* , *CODEUNITS16* | *CODEUNITS32* | *OCTETS*) ◄◄

Graphic to CLOB:

►► CLOB(*graphic-expression* , *integer* , *CODEUNITS16* | *CODEUNITS32*) ◄◄

The schema is SYSIBM.

Character to CLOB

character-expression

An expression that returns a value of a character string. If *character-expression* is bit data, an error occurs.

integer

An integer constant that specifies the length attribute of the resulting CLOB data type. The value must be between 1 and the maximum length of a CLOB, expressed in the units that are either implicitly or explicitly specified.

If you do not specify *integer* and *character-expression* is an empty string constant, the length attribute of the result is 1, and the result is an empty string. Otherwise, the length attribute of the result is the same as the length attribute of *character-expression*.

If CODEUNITS16 or CODEUNITS32 is specified, see [“Determining the length attribute of the final result”](#) on page 108 for information on how to calculate the length attribute of the result string.

CODEUNITS16, CODEUNITS32, or OCTETS

Specifies the unit that is used to express *integer*.

CODEUNITS16

Specifies that *integer* is expressed in terms of 16-bit UTF-16 code units.

CODEUNITS32

Specifies that *integer* is expressed in terms of 32-bit UTF-32 code units.

OCTETS

Specifies that *integer* is expressed in terms of bytes.

For more information about CODEUNITS16, CODEUNITS32, and OCTETS, see [“String unit specifications” on page 106](#).

The result of the function is a CLOB.

The result can be null; if the first argument is null, the result is the null value.

The actual length of the result is the minimum of the length attribute of the result and the actual length of *character-expression*. If the length of *character-expression* is greater than the length specified, the result is truncated. Unless all of the truncated characters are blanks, a warning is returned.

The CCSID of the result is the same as the CCSID of *character-expression*.

Graphic to CLOB

graphic-expression

An expression that returns a value of a graphic string.

integer

An integer constant that specifies the length attribute of the resulting CLOB data type. The value must be between 1 and the maximum length of a CLOB, expressed in the units that are either implicitly or explicitly specified.

If you do not specify *integer* and *graphic-expression* is an empty string constant, the length attribute of the result is 1, and the result is an empty string. Otherwise, the length attribute of the result is (3 * *length(graphic-expression)*).

If CODEUNITS16 or CODEUNITS32 is specified, see [“Determining the length attribute of the final result” on page 108](#) for information on how to calculate the length attribute of the result string.

CODEUNITS16 or CODEUNITS32

Specifies the unit that is used to express *integer*.

CODEUNITS16

Specifies that *integer* is expressed in terms of 16-bit UTF-16 code units.

CODEUNITS32

Specifies that *integer* is expressed in terms of 32-bit UTF-32 code units.

For more information about CODEUNITS16 and CODEUNITS32, see [“String unit specifications” on page 106](#).

The result of the function is a CLOB.

The result can be null; if the first argument is null, the result is the null value.

The actual length of the result is the minimum of the length attribute of the result and the actual length of *graphic-expression*. If the length of *graphic-expression* is greater than the length specified, the result is truncated. Unless all of the truncated characters are blanks, a warning is returned.

The CCSID of the result is the character mixed CCSID that corresponds to the graphic CCSID of *graphic-expression*.

Notes

Syntax alternatives:

[FL 506 TO_CLOB](#) is a synonym for CLOB.

Examples

Example 1: The following function returns a CLOB for the string 'This is a CLOB'.

```
SELECT CLOB('This is a CLOB')
FROM SYSIBM.SYSDUMMY1;
```

Example 2: FIRSTNME is a VARCHAR(12) column in table T1. One of its values is the 6-character string 'Jürgen'. When FIRSTNME has this value:

Function ...	Returns ...
CLOB(FIRSTNME,3,CODEUNITS32)	'Jüɀ' -- x'4AC3BC72'
CLOB(FIRSTNME,3,CODEUNITS16)	'Jüɀ' -- x'4AC3BC72'
CLOB(FIRSTNME,3,OCTETS)	'Jü' -- x'4AC3BC'

COALESCE scalar function

The COALESCE function returns the value of the first nonnull expression.



The schema is SYSIBM.

The arguments must be compatible. For more information on compatibility, refer to the compatibility matrix in [Table 30 on page 144](#). The arguments can be of either a built-in or user-defined data type.

The arguments are evaluated in the order in which they are specified, and the result of the function is the first argument that is not null. The result can be null only if all arguments can be null. The result is null only if all arguments are null.

The selected argument is converted, if necessary, to the attributes of the result. The attributes of the result are determined using the “[Rules for result data types](#)” on [page 166](#). If the COALESCE function has more than two arguments, the rules are applied to the first two arguments to determine a candidate result type. The rules are then applied to that candidate result type and the third argument to determine another candidate result type. This process continues until all arguments are analyzed and the final result type is determined.

If there are any mixed character string or graphic string and numeric arguments, the string value is implicitly cast to a DECFLOAT(34) value.

The COALESCE function can also handle a subset of the functions provided by CASE expressions. The result of using COALESCE(e1, e2) is the same as using the expression:

```
CASE WHEN e1 IS NOT NULL THEN e1 ELSE e2 END
```

VALUE can be specified as a synonym for COALESCE.

Example 1: Assume that SCORE1 and SCORE2 are SMALLINT columns in table GRADES, and that nulls are allowed in SCORE1 but not in SCORE2. Select all the rows in GRADES for which SCORE1 + SCORE2 > 100, assuming a value of 0 for SCORE1 when SCORE1 is null.

```
SELECT * FROM GRADES
WHERE COALESCE(SCORE1,0) + SCORE2 > 100;
```

Example 2: Assume that a table named DSN8C10.EMP contains a DATE column named HIREDATE, and that nulls are allowed for this column. The following query selects all rows in DSN8C10.EMP for which the date in HIREDATE is either unknown (null) or earlier than 1 January 1960.

```
SELECT * FROM DSN8C10.EMP
WHERE COALESCE(HIREDATE,DATE('1959-12-31')) < '1960-01-01';
```

The predicate could also be coded as COALESCE(HIREDATE, '1959-12-31') because, for comparison purposes, a string representation of a date can be compared to a date.

Example 3: Assume that for the years 1993 and 1994 there is a table that records the sales results of each department. Each table, S1993 and S1994, consists of a DEPTNO column and a SALES column, neither of which can be null. The following query provides the sales information for both years.

```
SELECT COALESCE(S1993.DEPTNO,S1994.DEPTNO) AS DEPT, S1993.SALES, S1994.SALES
FROM S1993 FULL JOIN S1994 ON S1993.DEPTNO = S1994.DEPTNO
ORDER BY DEPT;
```

The full outer join ensures that the results include all departments, regardless of whether they had sales or existed in both years. The COALESCE function allows the two join columns to be combined into a single column, which enables the results to be ordered.

COLLATION_KEY scalar function

The COLLATION_KEY function returns a varying-length binary string that represents the collation key of the argument in the specified collation.

► COLLATION_KEY(*string-expression* , *collation-name*) ►
 , — *integer* —

The schema is SYSIBM.

The result of COLLATION_KEY on one string can be compared in binary form with the result of COLLATION_KEY on another string to determine their order within the specified *collation-name*. For the comparison to be meaningful, the results of the COLLATION_KEY must be from the same *collation-name*.

string-expression

An expression that returns a character or graphic string that is not a LOB for which the collation key is to be determined. If *string-expression* is a character string, it must not be FOR BIT DATA. If *string-expression* is not in Unicode UTF-16 (CCSID 1200), it is converted to Unicode UTF-16 before the corresponding collation key is obtained. The length of *string-expression* must not exceed 32704 bytes of the UTF-16 representation.

collation-name

A string constant or a string host variable that is not a binary string, CLOB, or DBCLOB. *collation-name* specifies the collation to use when determining the collation key. If *collation-name* is not an EBCDIC value, it is converted to EBCDIC. The length of *collation-name* must be in the range 1–255 bytes of the EBCDIC representation. The value of *collation-name* is not case sensitive and must be a left justified, valid "short path" collation setting for the parameter CUNBOPRM_Collation_Keyword in area CUN4BOPR. For detailed information about the "short path" setting in the parameter CUNBOPRM_Collation_Keyword, see [Description of parameters in area CUNBOPRM \(z/OS: Unicode Services User's Guide and Reference\)](#).

The value of the host variable must not be null. If the host variable has an associated indicator variable, the value of the indicator variable must not indicate a null value. *collation-name* must be left justified within the host variable. It must also be padded on the right with blanks if the length is less than that of the host variable and the host variable is a fixed length CHAR or GRAPHIC data type.

collation-name is in the form of CUN4BOPR_Collation_Keyword specification. You must specify a value that is acceptable for the [z/OS CUNBOPR_Collation_Keyword parameter](#).

The following table lists some supported values:

Table 69. Collation Keywords Reference

Attribute name	Key	Possible values
Locale	L.R.V	<locale>
Strength	S	1, 2, 3, 4, I, D
Case_Level	K	X, O, D

Table 69. Collation Keywords Reference (continued)

Attribute name	Key	Possible values
Case_First	C	X, L, U, D
Alternate	A	N, S, D
Variable_Top	T	<hex digits>
Normalization	N	X, O, D
French	F	X, O, D
Hinayana	H	X, O, D

The following table describes the abbreviations for the collation keywords:

Abbreviation	Definition
D	default
O	on
X	off
1	primary
2	secondary
3	tertiary
4	quaternary
I	identical
S	shifted
N	non-ignorable
L	lower-first
U	upper-first

The following examples show keywords using the above specifications:

```
'UCA400R1_AS_LSV_S3_CU'
```

UCA version 4.0.1; ignore spaces, punctuation and symbols; use Swedish linguistic conventions; use case-first upper; compare case-sensitive.

```
'UCA400R1_AN_LSV_S3_CL_NO'
```

UCA version 4.0.1; do not ignore spaces, punctuation and symbols; use Swedish linguistic conventions; use case-first lower (or does not set it to mean the same, since lower is used in most locales as the default); normalization ON; compare case-sensitive.

integer

An integer value that specifies the length attribute of the result. If specified, the value must be an integer constant in the range 1–32704.

If the length is not specified, the length attribute of the result is determined as follows:

string-expression	Result length attribute
CHAR(<i>n</i>) or VARCHAR(<i>n</i>)	MIN (VARBINARY(12 <i>n</i>), 32704)
GRAPHIC(<i>n</i>) or VARGRAPHIC(<i>n</i>)	MIN (VARBINARY(12 <i>n</i>), 32704)

Regardless of whether the length is specified, the length of the collation key must be less than or equal to the length attribute of the result. The actual result length of the collation key is approximately six times of the length of *string-expression* where the length of *string-expression* is in Unicode byte representation. For certain *collation-name* such as UCA410_LKO_RKR (for Korean collation) the default length attribute of the result, 12*n*, might not be large enough and an error will be returned. To avoid such an error, the length attribute of the result must be explicitly specified to a larger constant. For the proper length attribute of the result, see [Description of parameters in area CUNBOPRM \(z/OS: Unicode Services User's Guide and Reference\)](#) for information about target buffer length considerations for Collation Services.

The result can be null; if the first argument is null, the result is the null value.

The COLLATION_KEY function uses Unicode Collation Services in z/OS to return the collation key. See [Locales supported for collation \(z/OS: Unicode Services User's Guide and Reference\)](#) for a list of supported collation versions.

If Unicode Collation Services are not available when the COLLATION_KEY function is run, an error is returned.

Example 1: The following query orders the employees by their surnames using the default Unicode Collation Algorithm V4.0.1(UCA), ignoring spaces, punctuation, and symbols, using Swedish linguistic conventions, and not comparing case:

```
SELECT FIRSTNAME, LASTNAME
FROM DSN8C10.EMP
ORDER BY COLLATION_KEY(LASTNAME, 'UCA400R1_AS_LSV_S2');
```

Example 2: The following query uses the COLLATION_KEY function on the LASTNAME column and the SALES_PERSON column to obtain the sort keys from the same collation name in order to do a culturally correct comparison. It finds the departments of employees in Quebec:

```
SELECT E.WORKDEPT
FROM EMPLOYEE AS E INNER JOIN SALES AS S
ON COLLATION_KEY(E.LASTNAME, 'UCA400R1_LFR_RCA') =
   COLLATION_KEY(S.SALES_PERSON, 'UCA400R1_LFR_RCA')
WHERE S.REGION = 'Quebec';
```

Example 3: Create an index EMPLOYEE_NAME_SORT_KEY for table EMPLOYEE based on built-in function COLLATION_KEY with collation name 'UCA410_LDE' tailored for German.

```
CREATE INDEX EMPLOYEE_NAME_SORT_KEY
ON EMPLOYEE (COLLATION_KEY(LASTNAME, 'UCA410_LDE', 600),
             COLLATION_KEY(FIRSTNAME, 'UCA410_LDE', 600),
             ID);
```

Related reference

[Description of parameters in area CUN4BOPR \(z/OS: Unicode Services User's Guide and Reference\)](#)

[Locales supported for collation \(z/OS: Unicode Services User's Guide and Reference\)](#)

COMPARE_DECFLOAT scalar function

The COMPARE_DECFLOAT function returns a SMALLINT value that indicates whether the two arguments are equal or unordered, or whether one argument is greater than the other.

```
► COMPARE_DECFLOAT( decfloat-expression1 , decfloat-expression2 ) ◄
```

The schema is SYSIBM.

decfloat-expression1

An expression that returns a DECFLOAT value.

decfloat-expression2

An expression that returns a DECFLOAT value.

decfloat-expression1 is compared with *decfloat-expression2* and the result is returned according to the following rules:

- If both arguments are finite, the comparison is algebraic and follows the procedure for DECFLOAT subtraction. If the difference is exactly zero with either sign, the arguments are equal. If a nonzero difference is positive, the first argument is greater than the second argument. If a nonzero difference is negative, the first argument is less than the second.
- Positive zero and negative zero compare as equal.
- Positive infinity compares equal to positive infinity.
- Positive infinity compares greater than any finite number.
- Negative infinity compares equal to negative infinity.
- Negative infinity compares less than any finite number.
- Numeric comparison is exact and the result is determined for finite operands as if range and precision were unlimited. Overflow or underflow cannot occur.
- If either argument is NaN or sNaN (positive or negative), the result is unordered.

Numeric comparison is exact, and the result is determined for finite operands as if the range and precision were unlimited. An overflow or underflow condition cannot occur.

If one argument is DECFLOAT(16) and the other is DECFLOAT(34), the DECFLOAT(16) value is converted to DECFLOAT(34) before the comparison is made.

The arguments can also be a character string or graphic string data type. The string input is implicitly cast to a numeric value of DECFLOAT(34).

One of the following values will be the result:

0

The arguments are exactly equal

1

decfloat-expression1 is less than *decfloat-expression2*

2

decfloat-expression1 is greater than *decfloat-expression2*

3

The arguments are unordered

The result of the function is a SMALLINT value.

The result can be null; if any argument is null, the result is the null value.

Examples: The following examples demonstrate the values that will be returned when the function is used:

```
COMPARE_DECFLOAT(DECFLOAT(2.17) , DECFLOAT(2.17))      = 0
COMPARE_DECFLOAT(DECFLOAT(2.17) , DECFLOAT(2.170))    = 2
```

COMPARE_DECFLOAT(DECFLOAT(2.170), DECFLOAT(2.17))	= 1
COMPARE_DECFLOAT(DECFLOAT(2.17), DECFLOAT(0.0))	= 2
COMPARE_DECFLOAT(INFINITY, INFINITY)	= 0
COMPARE_DECFLOAT(INFINITY, -INFINITY)	= 2
COMPARE_DECFLOAT(DECFLOAT(-2), INFINITY)	= 1
COMPARE_DECFLOAT(NAN, NAN)	= 3
COMPARE_DECFLOAT(DECFLOAT(-0.1), SNAN)	= 3

CONCAT scalar function

The CONCAT function combines two compatible string arguments.

►► CONCAT(*string-expression-1* , *string-expression-2*) ◄◄

The schema is SYSIBM.

The arguments must be compatible strings. For more information on compatibility, refer to the compatibility matrix in [Table 30 on page 144](#).

Either argument can also be a numeric data type. The numeric argument is implicitly cast to a VARCHAR data type.

The result of the function is a string that consists of the first string followed by the second string.

The result can be null; if any argument is null, the result is the null value.

The CONCAT function is identical to the CONCAT operator. For more information, see [“Concatenation operators in expressions” on page 247](#).

Example: Using sample table DSN8C10.EMP, concatenate column FIRSTNME with column LASTNAME. Both columns are defined as varying-length character strings.

```
SELECT CONCAT(FIRSTNME, LASTNAME)
FROM DSN8C10.EMP;
```

CONTAINS scalar function

The CONTAINS function searches a text search index using criteria that are specified in a search argument and returns a result about whether or not a match was found.

Requirement: To use the CONTAINS function, Text Search for Db2 for z/OS must be installed and configured. See [IBM Text Search for Db2 for z/OS \(IBM Text Search for Db2 for z/OS Installation, Administration, and Reference\)](#) for more information.

►► CONTAINS — (— *column-name* — , — *search-argument* —) ◄◄
└── , — *string-constant* ¹ ─┘

Notes:

¹ *string-constant* must conform to the rules for the *search-argument-options*.

search-argument-options

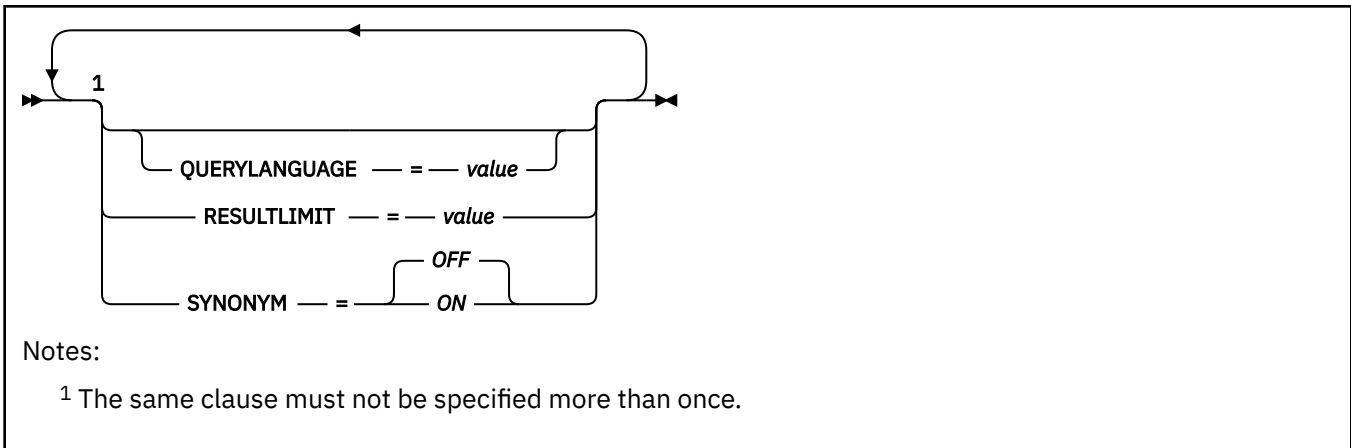

The schema is SYSIBM.

column-name

Specifies a qualified or unqualified name of a column that has a text search index that is to be searched. The column must exist in the table or view that is identified in the FROM clause in the statement and the column of the table, or the column of the underlying base table of the view must have an associated text search index. The underlying expression of the column of a view must be a simple column reference to the column of an underlying table, directly or through another nested view.

search-argument

Specifies an expression that returns a value that is a string value (except a LOB) that contains the terms to be searched for and must not be all blanks or the empty string. The actual length of the string must not exceed 4096 Unicode characters. The value is converted to Unicode before it is used to search the text search index. The maximum number of terms per query must not exceed 1024.

string-constant

Identifies a string constant that specifies the search argument options that are in effect for the function.

The options that can be specified as part of the *search-argument-options* are as follows:

QUERYLANGUAGE = value

Specifies the query language. The value can be any of the supported language codes. If the QUERYLANGUAGE option is not specified, the default is the language value of the text search index that is used when this function is invoked. If the language value of the text search index is AUTO, the default value for QUERYLANGUAGE is en_US.

RESULTLIMIT = value

Specifies the maximum number of results to be returned from the underlying search engine. The *value* can be an integer value in the range 1–2 147 483 647. If the RESULTLIMIT option is not specified, no result limit is in effect for the query.

This scalar function cannot be called for each row of the result table, depending on the plan that the optimizer chooses. This function can be called once for the query to the underlying search engine, and a result set of all of the primary keys that match are returned from the search engine. This result set is then joined to the table containing the column to identify the result rows. In this case, the RESULTLIMIT value acts like a FETCH FIRST ?? ROWS from the underlying text search engine and can be used as an optimization. If the search engine is called for each row of the result because the optimizer determines that is the best plan, then the RESULTLIMIT option has no effect. Also, the RESULTLIMIT option has no effect when the CONTAINS function is used along with the comparison operators (<, >, <=, and >=) or the equality operator (=) and a value of 0 (zero).

SYNONYM = OFF or SYNONYM = ON

Specifies whether to use a synonym dictionary that is associated with the text search index. Use the Synonym Tool to add a synonym dictionary to the collection. The default is OFF.

OFF

Do not use a synonym dictionary.

ON

Use the synonym dictionary that is associated with the text search index.

The result of the function is a large integer. If the second argument can be null, the result can be null. If the second argument is null, the result is the null value. If the third argument is null, the result is as if the third argument was not specified.

The result is 1 if the document contains a match for the search criteria that are specified in the search argument. Otherwise, the result is 0.

CONTAINS is a non-deterministic function.

Examples**Example 1**

Assume that information about employees' skills are stored in a table named EMP_RESUME. The following statement finds all of the employees who have "COBOL" in their resume. The text search argument is not case-sensitive.

```
SELECT EMPNO
   FROM EMP_RESUME
  WHERE RESUME_FORMAT = 'ascii'
     AND CONTAINS(RESUME, 'cobol') = 1
```

Example 2

The search argument does not need to be a string constant. The search argument can be any SQL string expression, including a string contained in a host variable.

The following statement searches for the exact term "ate" in the COMMENT column:

```
char search_arg[100]; /* input host variable */
...
EXEC SQL DECLARE C3 CURSOR FOR
  SELECT CUSTKEY
   FROM K55ADMIN.CUSTOMERS
  WHERE CONTAINS(COMMENT, :search_arg)= 1
  ORDER BY CUSTKEY;
strcpy(search_arg, "ate");
EXEC SQL OPEN C3;
...
```

Example 3

The following statement finds 10 students at random who wrote online essays that contain the phrase "fossil fuel" in Spanish, which is "combustible fósil." These students will be invited for a radio interview.

Use the synonym dictionary that was created for the associated text search index. Because only 10 students are needed, you can optimize the query by using the RESULTLIMIT option to limit the number of results from the underlying text search server.

```
SELECT FIRSTNAME, LASTNAME
   FROM STUDENT_ESSAYS
  WHERE CONTAINS(TERM_PAPER, 'combustible fósil',
    'QUERYLANGUAGE= es_ES RESULTLIMIT = 10 SYNONYM=ON') = 1
```

Example 4

The following example shows how the CAST specification can be used in a dynamically prepared statement to provide a typed parameter marker as an argument to the CONTAINS function. The CAST specification defines the data type for the parameter marker (?).

```
CONTAINS(C1,CAST(? AS CHAR(10)))
```

COS scalar function

The COS function returns the cosine of the argument, where the argument is an angle, expressed in radians. The COS and ACOS functions are inverse operations.

►► COS(*numeric-expression*) ◄◄

The schema is SYSIBM.

The argument must be an expression that returns the value of any built-in numeric data type that is not DECFLOAT. If the argument is not a double precision floating-point number, it is converted to one for processing by the function.

The result of the function is a double precision floating-point number.

The result can be null; if the argument is null, the result is the null value.

Example: Assume that host variable COSINE is DECIMAL(2,1) with a value of 1.5. The following statement returns a double precision floating-point number with an approximate value of 0.07:

```
SELECT COS(:COSINE)
FROM SYSIBM.SYSDUMMY1;
```

COSH scalar function

The COSH function returns the hyperbolic cosine of the argument, where the argument is an angle, expressed in radians.

►► COSH(*numeric-expression*) ◄◄

The schema is SYSIBM.

The argument must be an expression that returns the value of any built-in numeric data type that is not DECFLOAT. If the argument is not a double precision floating-point number, it is converted to one for processing by the function.

The result of the function is a double precision floating-point number.

The result can be null; if the argument is null, the result is the null value.

Example: Assume that host variable HCOS is DECIMAL(2,1) with a value of 1.5. The following statement returns a double precision floating-point number with an approximate value of 2.35:

```
SELECT COSH(:HCOS)
FROM SYSIBM.SYSDUMMY1;
```

DATE scalar function

The DATE function returns a date that is derived from a value.

►► DATE(*expression*) ◄◄

The schema is SYSIBM.

The argument must be an expression that returns one of the following built-in data types: a date, a timestamp, a character string, a graphic string, or any numeric data type.

- If *expression* is a character or graphic string, it must not be a CLOB or DBCLOB, and it must have one of the following values:

- A valid string representation of a date or timestamp with an actual length that is not greater than 255 bytes. For the valid formats of string representations of dates and timestamps, see [“String representations of datetime values”](#) on page 120.
- A character or graphic string with an actual length of 7 that represents a valid date in the form *yyyynnn*, where *yyyy* are digits denoting a year and *nnn* are digits between 001 and 366 denoting a day of that year.
- If *expression* is a number, it must be greater than or equal to one and less than or equal to 3652059.

If *expression* is not a DATE value, *expression* is cast as follows:

- If *expression* is a TIMESTAMP WITH TIME ZONE value, *expression* is cast to TIMESTAMP WITHOUT TIME ZONE, with the same precision as *expression*.
- If *expression* is a string, *expression* is cast to DATE.

The result of the function is a date.

The result can be null; if the argument is null, the result is the null value.

The other rules depend on the data type of the argument:

If the argument is a timestamp, the result is the date part of the timestamp.

If the argument is a date, the result is that date.

If the argument is a number, the result is the date that is *n*-1 days after January 1, 0001, where *n* is the integral part of the number.

If the argument is a string, the result is the date that is represented by the string. If the string contains a time zone, the time zone is ignored. If the CCSID of the string is not the same as the corresponding default CCSID at the server, the string is first converted to that CCSID.

The result CCSID is the appropriate CCSID of the argument encoding scheme and the result subtype is the appropriate subtype of the CCSID.

Example 1: Assume that RECEIVED is a TIMESTAMP column in some table, and that one of its values is equivalent to the timestamp '1988-12-25-17.12.30.000000'. For this value, the following statement returns the internal representation of 25 December 1988.

```
DATE (RECEIVED)
```

Example 2: Assume that DATCOL is a CHAR(7) column in some table, and that one of its values is the character string '1989061', which represents a date in the format *yyyynnn*, where *yyyy* is the year, and *nnn* is the day of the year. For this value, the following statement returns the internal representation of 2 March 1989.

```
DATE (DATCOL)
```

Example 3: Db2 recognizes '1989-03-02' as the ISO representation of 2 March 1989. So, the following statement returns the internal representation of 2 March 1989.

```
DATE ('1989-03-02')
```

DAY scalar function

The DAY function returns the day part of a value.

```
►► DAY(expression) ◄◄
```

The schema is SYSIBM.

The argument must be an expression that returns one of the following built-in data types: a date, a timestamp, a character string, a graphic string, or any numeric data type.

- If *expression* is a character or graphic string, it must not be a CLOB or DBCLOB, and its value must be a valid string representation of a date or timestamp with an actual length that is not greater than 255 bytes. For the valid formats of string representations of dates and timestamps, see [“String representations of datetime values”](#) on page 120.
- If *expression* is a number, it must be a date duration or a timestamp duration. For the valid formats of datetime durations, see [“Datetime operands”](#) on page 169.

If *expression* is a timestamp with a time zone value, or a valid string representation of a timestamp with a time zone, the result is determined from the UTC representation of the datetime value.

The result of the function is a large integer.

The result can be null; if the argument is null, the result is the null value.

The other rules for the function depend on the data type of the argument:

If the argument is a date, timestamp, or string representation of either, the result is the day part of the value, which is an integer in the range 1–31.

If the argument is a date duration or timestamp duration, the result is the day part of the value, which is an integer between -99 and 99. A nonzero result has the same sign as the argument.

If the argument contains a time zone, the result is the day part of the value expressed in UTC.

Examples for DAY

Example 1

Set the INTEGER host variable DAYVAR to the day of the month on which employee 140 in the sample table DSN8C10.EMP was hired.

```
EXEC SQL SELECT DAY(HIREDATE)
          INTO :DAYVAR
          FROM DSN8C10.EMP
          WHERE EMPNO = '000140';
```

Example 2

Assume that DATE1 and DATE2 are DATE columns in the same table. Assume also that for a given row in this table, DATE1 and DATE2 represent the dates 15 January 2000 and 31 December 1999, respectively. Then, for the given row, the following function invocation returns 15.

```
DAY (DATE1 - DATE2)
```

Example 3

The following invocations of the DAY function all return the same result, which is 2. When the input argument contains a time zone, the result is determined from the UTC representation of the input value. The string representations of timestamps with a time zone in the example SELECT statement all have the same UTC representation: 2003-01-02-20.00.00. The day portion of the UTC representation is 2.

```
SELECT DAY ('2003-01-02-20.00.00'),
       DAY ('2003-01-02-12.00.00-08:00'),
       DAY ('2003-01-03-05.00.00+09:00')
FROM SYSIBM.SYSDUMMY1;
```

Related concepts

[Date, time, and timestamp data types \(Introduction to Db2 for z/OS\)](#)

[Datetime values](#)

Datetime values are neither strings nor numbers. Nevertheless, datetime values can be used in certain arithmetic and string operations and are compatible with certain strings.

DAYOFMONTH scalar function

The DAYOFMONTH function returns the day part of a value. The function is similar to the DAY function, except DAYOFMONTH does not support a date or timestamp duration as an argument.

►► DAYOFMONTH(*expression*) ◄◄

The schema is SYSIBM.

The argument must be an expression that returns a value of a date, a timestamp, a character string, or a graphic string built-in data type.

If *expression* is a character or graphic string, it must not be a CLOB or DBCLOB, and its value must be a valid string representation of a date or timestamp with an actual length that is not greater than 255 bytes. For the valid formats of string representations of dates and timestamps, see [“String representations of datetime values”](#) on page 120.

If *expression* is a timestamp with a time zone value, or a valid string representation of a timestamp with a time zone, the result is determined from the UTC representation of the datetime value.

The result of the function is a large integer in the range 1–31, which represents the day part of the value.

The result can be null; if the argument is null, the result is the null value.

Examples for DAYOFMONTH

Example 1

Set the INTEGER variable DAYVAR to the day of the month on which employee 140 in sample table DSN8C10.EMP was hired.

```
SELECT DAYOFMONTH(HIREDATE)
       INTO :DAYVAR
       FROM DSN8C10.EMP
       WHERE EMPNO = '000140';
```

Example 2

The following invocations of the DAYOFMONTH function return the same result, which is 2. When the input argument contains a time zone, the result is determined from the UTC representation of the input value. The string representations of timestamps with a time zone in the example SELECT statement all have the same UTC representation: 2003-01-02-20.00.00. The day portion of the UTC representation is 2.

```
SELECT DAYOFMONTH('2003-01-02-20.00.00'),
       DAYOFMONTH('2003-01-02-12.00.00-08:00'),
       DAYOFMONTH('2003-01-03-05.00.00+09:00')
       FROM SYSIBM.SYSDUMMY1;
```

Related concepts

[Date, time, and timestamp data types \(Introduction to Db2 for z/OS\)](#)

[Datetime values](#)

Datetime values are neither strings nor numbers. Nevertheless, datetime values can be used in certain arithmetic and string operations and are compatible with certain strings.

DAYOFWEEK scalar function

The DAYOFWEEK function returns an integer, in the range 1–7 that represents the day of the week, where 1 is Sunday and 7 is Saturday. The DAYOFWEEK function is similar to the DAYOFWEEK_ISO function.

►► DAYOFWEEK(*expression*) ◄◄

The schema is SYSIBM.

The argument must be an expression that returns a value of one of the following built-in data types: a date, a timestamp, a character string, or a graphic string.

If *expression* is a character or graphic string, it must not be a CLOB or DBCLOB, and its value must be a valid string representation of a date or timestamp with an actual length that is not greater than 255 bytes. For the valid formats of string representations of dates and timestamps, see [“String representations of datetime values”](#) on page 120.

If *expression* is a timestamp with a time zone, or a valid string representation of a timestamp with a time zone, the result is determined from the UTC representation of the datetime value.

The result of the function is a large integer.

Examples for DAYOFWEEK

The result can be null; if the argument is null, the result is the null value.

Example 1

The following statement uses sample table DSN8C10.EMP, set the integer host variable DAY_OF_WEEK to the day of the week that Christine Haas (EMPNO = '000010') was hired (HIREDATE). The result is that DAY_OF_WEEK is set to 6, which represents Friday.

```
SELECT DAYOFWEEK(HIREDATE)
       INTO :DAY_OF_WEEK
       FROM DSN8C10.EMP
       WHERE EMPNO = '000010';
```

Example 2

The following query returns four values: 1, 2, 1, and 2.

```
SELECT DAYOFWEEK(CAST('10/11/1998' AS DATE)),
       DAYOFWEEK(TIMESTAMP('10/12/1998', '01.02')),
       DAYOFWEEK(CAST(CAST('10/11/1998' AS DATE) AS CHAR(20))),
       DAYOFWEEK(CAST(TIMESTAMP('10/12/1998', '01.02') AS CHAR(26)))
       FROM SYSIBM.SYSDUMMY1;
```

Example 3

The following invocations of the DAYOFWEEK function all return the value 5, which represents Thursday. (1 represents Sunday for DAYOFWEEK results.) When the input argument contains a time zone, the result is determined from the UTC representation of the input value. The string representations of the example timestamp with time zone values in the SELECT statement all have the same UTC representation: 2003-01-02-20.00.00.

```
SELECT DAYOFWEEK('2003-01-02-20.00.00'),
       DAYOFWEEK('2003-01-02-12.00.00-08:00'),
       DAYOFWEEK('2003-01-03-05.00.00+09:00')
       FROM SYSIBM.SYSDUMMY1;
```

Related concepts

[Date, time, and timestamp data types \(Introduction to Db2 for z/OS\)](#)

[Datetime values](#)

Datetime values are neither strings nor numbers. Nevertheless, datetime values can be used in certain arithmetic and string operations and are compatible with certain strings.

Related reference

[DAYOFWEEK_ISO scalar function](#)

The DAYOFWEEK_ISO function returns an integer in the range 1–7 that represents the day of the week, where 1 is Monday and 7 is Sunday. The DAYOFWEEK_ISO function is similar to the DAYOFWEEK function.

DAYOFWEEK_ISO scalar function

The DAYOFWEEK_ISO function returns an integer in the range 1–7 that represents the day of the week, where 1 is Monday and 7 is Sunday. The DAYOFWEEK_ISO function is similar to the DAYOFWEEK function.

►► DAYOFWEEK_ISO(*expression*) ◄◄

The schema is SYSIBM.

The argument must be an expression that returns a value of one of the following built-in data types: a date, a timestamp, a character string, or graphic string.

If *expression* is a character or graphic string, it must not be a CLOB or DBCLOB, and its value must be a valid string representation of a date or timestamp with an actual length that is not greater than 255 bytes. For the valid formats of string representations of dates and timestamps, see [“String representations of datetime values”](#) on page 120.

If *expression* is a timestamp with a time zone, or a valid string representation of a timestamp with a time zone, the result is determined from the UTC representation of the datetime value.

The result of the function is a large integer.

The result can be null; if the argument is null, the result is the null value.

Examples for DAYOFWEEK_ISO

Example 1

Using sample table DSN8C10.EMP, set the integer host variable DAY_OF_WEEK to the day of the week that Christine Haas (EMPNO = '000010') was hired (HIREDATE). The result is that DAY_OF_WEEK is set to 5, which represents Friday.

```
SELECT DAYOFWEEK_ISO(HIREDATE)
       INTO :DAY_OF_WEEK
       FROM DSN8C10.EMP
       WHERE EMPNO = '000010';
```

Example 2

The following query returns the following values: 7, 1, 7, and 1.

```
SELECT DAYOFWEEK_ISO(CAST('10/11/1998' AS DATE)),
       DAYOFWEEK_ISO(TIMESTAMP('10/12/1998', '01.02')),
       DAYOFWEEK_ISO(CAST(CAST('10/11/1998' AS DATE) AS CHAR(20))),
       DAYOFWEEK_ISO(CAST(TIMESTAMP('10/12/1998', '01.02') AS CHAR(26)))
       FROM SYSIBM.SYSDUMMY1;
```

Example 3

The following table shows what is returned by the DAYOFWEEK_ISO function for various dates.

DATE	DAYOFWEEK_ISO returns:
2003-12-28	7
2003-12-31	3
2004-01-01	4

DATE	DAYOFWEEK_ISO returns:
2004-01-10	6
2005-12-31	7
2006-01-01	7
2006-01-03	2

Example 4

The following invocations of the DAYOFWEEK_ISO function all return the same result, which is 4 for Thursday. (1 represents Monday in DAYOFWEEK_ISO results.) When the input argument contains a time zone, the result is determined from the UTC representation of the input value. The string representations of timestamps with a time zone in the example SELECT statement all have the same UTC representation: 2003-01-02-20.00.00.

```
SELECT DAYOFWEEK_ISO('2003-01-02-20.00.00'),
       DAYOFWEEK_ISO('2003-01-02-12.00.00-08:00'),
       DAYOFWEEK_ISO('2003-01-03-05.00.00+09:00')
FROM SYSIBM.SYSDUMMY1;
```

Related concepts

[Date, time, and timestamp data types \(Introduction to Db2 for z/OS\)](#)

[Datetime values](#)

Datetime values are neither strings nor numbers. Nevertheless, datetime values can be used in certain arithmetic and string operations and are compatible with certain strings.

Related reference

[DAYOFWEEK scalar function](#)

The DAYOFWEEK function returns an integer, in the range 1–7 that represents the day of the week, where 1 is Sunday and 7 is Saturday. The DAYOFWEEK function is similar to the DAYOFWEEK_ISO function.

DAYOFYEAR scalar function

The DAYOFYEAR function returns an integer, in the range 1–366 that represents the day of the year, where 1 is January 1.

►► DAYOFYEAR(*expression*) ◄◄

The schema is SYSIBM.

The argument must be an expression that returns a value of one of the following built-in data types: a date, a timestamp, a character string, or a graphic string.

If *expression* is a character or graphic string, it must not be a CLOB or DBCLOB, and its value must be a valid string representation of a date or timestamp with an actual length that is not greater than 255 bytes. For the valid formats of string representations of dates and timestamps, see [“String representations of datetime values”](#) on page 120.

If *expression* is a timestamp with a time zone value, or a valid string representation of a timestamp with a time zone, the result is determined from the UTC representation of the datetime value.

The result of the function is a large integer.

The result can be null; if the argument is null, the result is the null value.

Examples for DAYOFYEAR

Example 1

Using sample table DSN8C10.EMP, set the integer host variable AVG_DAY_OF_YEAR to the average of the day of the year on which employees were hired (HIREDATE). The result is that AVG_DAY_OF_YEAR is set to 202.

```
SELECT AVG(DAYOFYEAR(HIREDATE))
       INTO :AVG_DAY_OF_YEAR
FROM DSN8C10.EMP;
```

Example 2

The following invocations of the DAYOFYEAR function all return the same result, which is 2. When the input argument contains a time zone, the result is determined from the UTC representation of the input value. The string representations of timestamps with a time zone in the example SELECT statement all have the same UTC representation: 2003-01-02-20.00.00.

```
SELECT DAYOFYEAR('2003-01-02-20.00.00'),
       DAYOFYEAR('2003-01-02-12.00.00-08:00'),
       DAYOFYEAR('2003-01-03-05.00.00+09:00')
FROM SYSIBM.SYSDUMMY1;
```

Related concepts

[Date, time, and timestamp data types \(Introduction to Db2 for z/OS\)](#)

[Datetime values](#)

Datetime values are neither strings nor numbers. Nevertheless, datetime values can be used in certain arithmetic and string operations and are compatible with certain strings.

DAYS scalar function

The DAYS function returns an integer representation of a date.

►► DAYS(*expression*) ◄◄

The schema is SYSIBM.

The argument must be an expression that returns a value of one of the following built-in data types: a date, a timestamp, a character string, or a graphic string.

If *expression* is a character or graphic string, it must not be a CLOB or DBCLOB, and its value must be a valid string representation of a date or timestamp with an actual length that is not greater than 255 bytes. For the valid formats of string representations of dates and timestamps, see [“String representations of datetime values”](#) on page 120.

If *expression* is a timestamp with a time zone value, or a valid string representation of a timestamp with a time zone, the result is determined from the UTC representation of the datetime value.

The result of the function is a large integer.

The result can be null; if the argument is null, the result is the null value.

The result is 1 more than the number of days from January 1, 0001 to *D*, where *D* is the date that would occur if the DATE function were applied to the argument.

Examples for DAYS

Example 1

Set the INTEGER host variable DAYSVAR to the number of days that employee 140 had been with the company on the last day of 1997.

```
EXEC SQL SELECT DAYS('1997-12-31') - DAYS(HIREDATE) + 1
       INTO :DAYSVAR
```

```
FROM DSN8C10.EMP
WHERE EMPNO = '000140';
```

Example 2

The following invocations of the DAYS function all return the same result, which is 731217. When the input argument contains a time zone, the result is determined from the UTC representation of the input value. The string representations of timestamps with a time zone in the example SELECT statement all have the same UTC representation: 2003-01-02-20.00.00.

```
SELECT DAYS('2003-01-02-20.00.00'),
       DAYS('2003-01-02-12.00.00-08:00'),
       DAYS('2003-01-03-05.00.00+09:00')
FROM SYSIBM.SYSDUMMY1;
```

Related concepts

[Date, time, and timestamp data types \(Introduction to Db2 for z/OS\)](#)

[Datetime values](#)

Datetime values are neither strings nor numbers. Nevertheless, datetime values can be used in certain arithmetic and string operations and are compatible with certain strings.

DAYS_BETWEEN scalar function

The DAYS_BETWEEN function returns the number of full days between the specified arguments.

[FL 507](#)

Passthrough-only expression: This function is passthrough-only and cannot run on Db2 for z/OS without acceleration. For information about invoking this function, see [Accelerating queries with passthrough-only expressions](#).

➤ DAYS_BETWEEN — (— *expression1* — , — *expression2* —) ➤

The schema is SYSIBM.

expression1

An expression that specifies the first datetime value to compute the number of full days between two datetime values. The expression must return a value that is a DATE, TIMESTAMP WITHOUT TIME ZONE, CHAR, VARCHAR, GRAPHIC, or VARGRAPHIC data type. CHAR, VARCHAR, GRAPHIC, and VARGRAPHIC are supported by using implicit casting. If *expression1* is a CHAR, VARCHAR, GRAPHIC, or VARGRAPHIC data type, it must be a valid string that is accepted by the TIMESTAMP scalar function and does not contain a time zone.

expression2

An expression that specifies the second datetime value to compute the number of full days between two datetime values. The expression must return a value that is a DATE, TIMESTAMP WITHOUT TIME ZONE, CHAR, VARCHAR, GRAPHIC, or VARGRAPHIC data type. CHAR, VARCHAR, GRAPHIC, and VARGRAPHIC are supported by using implicit casting. If *expression2* is a CHAR, VARCHAR, GRAPHIC, or VARGRAPHIC data type, it must be a valid string that is accepted by the TIMESTAMP scalar function and does not contain a time zone.

If there is less than a full day between *expression1* and *expression2*, the result is zero. If *expression1* is later than *expression2*, the result is positive. If *expression1* is earlier than *expression2*, the result is negative. If *expression1* or *expression2* contains time information, this information is also used to determine the number of full days. If *expression1* or *expression2* does not contain time information, a time of midnight (00.00.00) is used for the argument that is missing time information.

The result of the function is an INTEGER. If either argument can be null, the result can be null. If either argument is null, the result is the null value.

Examples

- Set the host variable NUM_DAYS with the number of full days between 2012-03-03 and 2012-02-28.

```
SET :NUM_DAYS = DAYS_BETWEEN(DATE '2012-03-03',
DATE '2012-02-28')
```

The host variable NUM_DAYS is set to 4 because an additional day is incurred for February 29, 2012.

- Set the host variable NUM_DAYS with the number of full days between 2013-09-11-23.59.59 and 2013-09-01-00.00.00.

```
SET :NUM_DAYS = DAYS_BETWEEN(TIMESTAMP '2013-09-11-23.59.59',
TIMESTAMP '2013-09-01-00.00.00')
```

The host variable NUM_DAYS is set to 10 because there is 1 second less than a full 11 days between the arguments. It is positive because the first argument is later than the second argument.

- Set the host variable NUM_DAYS with the number of full days between 2013-09-01-00.00.00 and 2013-09-11-23.59.59.

```
SET :NUM_DAYS = DAYS_BETWEEN(TIMESTAMP '2013-09-01-00.00.00',
TIMESTAMP '2013-09-11-23.59.59')
```

The host variable NUM_DAYS is set to -10 because there is 1 second less than a full 11 days between the arguments. It is negative because the first argument is earlier than the second argument.

DBCLOB scalar function

The DBCLOB function returns a DBCLOB representation of a character string value (with the single-byte characters converted to double-byte characters) or a graphic string value.

Character to DBCLOB:

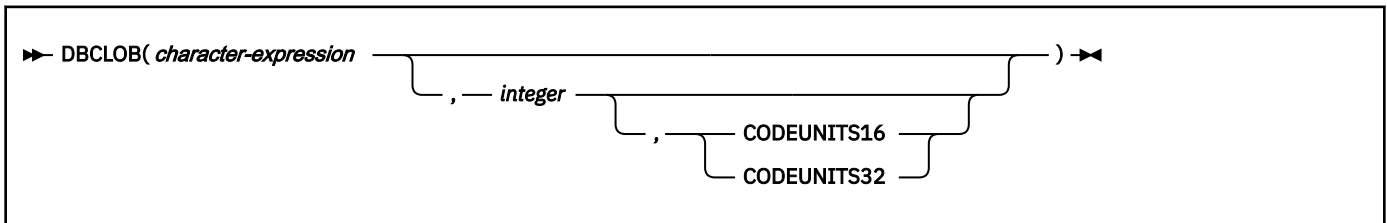

Graphic to DBCLOB:

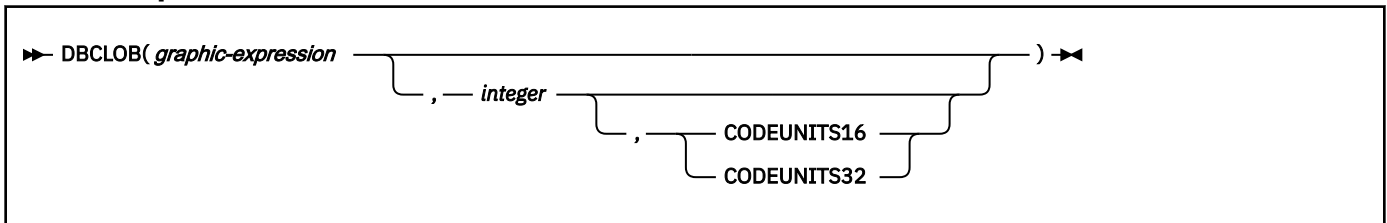

The schema is SYSIBM.

Character to DBCLOB

character-expression

An expression that returns a value that is an EBCDIC-encoded or Unicode-encoded character string. It cannot be BIT data. The argument does not need to be mixed data, but any occurrences of X'0E' and X'0F' in the string must conform to the rules for EBCDIC mixed data. (See [“Character strings” on page 102](#) for these rules.)

integer

The length attribute of the resulting DBCLOB. The value of *integer* must be between 1 and the maximum length of a DBCLOB, expressed in the units that are either implicitly or explicitly specified.

If CODEUNITS16 or CODEUNITS32 is specified, see [“Determining the length attribute of the final result” on page 108](#) for information about how to calculate the length attribute of the result string. If CODEUNITS32 is specified, the value of *integer* must be between 1 and the maximum length of a

DBCLOB divided by two (to allow for an intermediate result string that is long enough to evaluate the function).

If *integer* is not specified and *character-expression* is an empty string constant, the length attribute of the result is 1, and the result is an empty string. Otherwise, the length attribute of the result is the same as the length attribute of *character-expression*.

CODEUNITS16 or CODEUNITS32

Specifies the unit that is used to express *integer*. If CODEUNITS16 or CODEUNITS32 is specified, the input is EBCDIC, and there is no system CCSID for EBCDIC GRAPHIC data, an error occurs.

CODEUNITS16

Specifies that *integer* is expressed in terms of 16-bit UTF-16 code units.

CODEUNITS32

Specifies that *integer* is expressed in terms of 32-bit UTF-32 code units.

For more information about CODEUNITS16 and CODEUNITS32, see [“String unit specifications” on page 106](#).

The actual length of the result is the minimum of the length attribute of the result and the actual length of *character-expression*. If the length of *character-expression*, as measured in single-byte characters, is greater than the specified length of the result, as measured in double-byte characters, the result is truncated. Unless all the truncated characters are blanks appropriate for *character-expression*, a warning is returned.

The CCSID of the result is the graphic CCSID that corresponds to the character CCSID of *character-expression*.

For EBCDIC input data, each character of *character-expression* determines a character of the result. The argument might need to be converted to the native form of mixed data before the result is derived. Let *M* denote the system CCSID for mixed data. The argument is not converted if any of the following conditions is true:

- The argument is mixed data and its CCSID is *M*.
- The argument is SBCS data and its CCSID is the same as the system CCSID for SBCS data. In this case, the operation proceeds as if the CCSID of the argument is *M*.

Otherwise, the argument is a new string *S* derived by converting the characters to the coded character set identified by *M*. If there is no system CCSID for mixed data, conversion is to the coded character set that the system CCSID for SBCS data identifies.

The result is derived from *S* using the following steps:

- Each shift character (X'0E' or X'0F') is removed.
- Each double-byte character remains as is.
- Each single-byte character is replaced by a double-byte character.

The replacement for a single-byte character is the equivalent DBCS character if an equivalent exists. Otherwise, the replacement is X'FEFE'. The existence of an equivalent character depends on *M*. If there is no system CCSID for mixed data, the DBCS equivalent of X'xx' for EBCDIC is X'42xx', except for X'40', whose DBCS equivalent is X'4040'.

For Unicode input data, each character of *character-expression* determines a character of the result. The argument might need to be converted to the native form of mixed data before the result is derived. Let *M* denote the system CCSID for mixed data. The argument is not converted if any of the following conditions is true:

- The argument is mixed data, and its CCSID is *M*.
- The argument is SBCS data, and its CCSID is the same as the system CCSID for SBCS data. In this case, the operation proceeds as if the CCSID of the argument is *M*.

Otherwise, the argument is a new string *S* derived by converting the characters to the coded character set identified by *M*.

The result is derived from *S* using the following steps:

- Each non-supplementary character is replaced by a Unicode double-byte character (a UTF-16 code point). A non-supplementary character in UTF-8 is in the range 1–3 bytes.
- Each supplementary character is replaced by a pair of Unicode double-byte characters (a pair of UTF-16 code points).

The replacement for a single-byte character is the Unicode equivalent character if an equivalent exists. Otherwise, the replacement is X'FFFD'.

Graphic to DBCLOB

graphic-expression

An expression that returns a value that is an EBCDIC-encoded or Unicode-encoded graphic string.

integer

The length attribute for the resulting varying-length graphic string. The value must be an integer between 1 and the maximum length of a DBCLOB, expressed in the units that are either implicitly or explicitly specified.

If CODEUNITS16 or CODEUNITS32 is specified, see “[Determining the length attribute of the final result](#)” on page 108 for information about how to calculate the length attribute of the result string.

If *integer* is not specified and *graphic-expression* is an empty string constant, the length attribute of the result is 1, and the result is an empty string. Otherwise, the length attribute of the result is the same as the length attribute of *graphic-expression*.

CODEUNITS16 or CODEUNITS32

Specifies the unit that is used to express *integer*. If CODEUNITS16 or CODEUNITS32 is specified, the input is EBCDIC, and there is no system CCSID for EBCDIC GRAPHIC data, an error occurs.

CODEUNITS16

Specifies that *integer* is expressed in terms of 16-bit UTF-16 code units.

CODEUNITS32

Specifies that *integer* is expressed in terms of 32-bit UTF-32 code units.

For more information about CODEUNITS16 and CODEUNITS32, see “[String unit specifications](#)” on page 106.

The actual length of the result is the minimum of the length attribute of the result and the actual length of *graphic-expression*. If the length of *graphic-expression* is greater than the length attribute of the result, truncation is performed. Unless all of the truncated characters are double-byte blanks, a warning is returned.

The CCSID of the result is the same as the CCSID of *graphic-expression*.

The result of the function is a DBCLOB.

The result can be null; if the first argument is null, the result is the null value.

The length attribute and actual length of the result are measured in double-byte characters because the result is a graphic string.

Example 1: Assume that the application encoding scheme is Unicode. The following statement returns a graphic (UTF-16) host variable.

```
VALUES DBCLOB('123')
      INTO :GHV1;
```

Example 2: FIRSTNAME is a VARCHAR(12) column (Unicode UTF-8 data) in table T1. One of its values is the 6-character string 'Jürgen'. When FIRSTNAME has this value:

Function ...	Returns ...
DBCLOB(FIRSTNAME, 3, CODEUNITS32)	'Jür' -- x'004A00FC0072'
DBCLOB(FIRSTNAME, 3, CODEUNITS16)	'Jür' -- x'004A00FC0072'

DECFLOAT scalar function

The DECFLOAT function returns a decimal floating-point representation of either a number or a character string representation of a number, a decimal number, an integer, a floating-point number, or a decimal floating-point number.

Numeric to DECFLOAT:



String to DECFLOAT:



The schema is SYSIBM.

Numeric to DECFLOAT

numeric-expression

An expression that returns a value of any built-in numeric data type.

34 or 16

Specifies the number of digits of precision for the result. The default is 34.

String to DECFLOAT

string-expression

An expression that returns a value of a character or graphic string (except a CLOB or DBCLOB) with a length attribute that is not greater than 255 bytes. Leading and trailing blanks are eliminated, and the resulting string is folded to uppercase. The expression must conform to the rules for forming a floating-point, decimal floating-point, integer, or decimal constant.

Use the *string-expression* syntax variation to specify a negative zero as a constant, or to preserve the precision of a floating point constant.

34 or 16

Specifies the number of digits of precision for the result. The default is 34.

The result is the same number that would result from `CAST(string-expression AS DECFLOAT(n))` or `CAST(numeric-expression AS DECFLOAT(n))`. Leading and trailing blanks are removed from the string, and the resulting substring must conform to the rules for forming a string representation of an SQL decimal-floating point constant.

If necessary, the source is rounded to the precision of the target.

For static SQL statements other than CREATE VIEW, the ROUNDING bind option or the native SQL procedure option determines the rounding mode.

For dynamic SQL statements (and static CREATE VIEW statements), the special register CURRENT DECFLOAT ROUNDING MODE determines the rounding mode.

The result of the function is a DECFLOAT with the implicitly or explicitly specified number of digits of precision.

The result can be null; if the first argument is null, the result is the null value.

Note: To increase the portability of applications, use the CAST specification. For more information, see “CAST specification” on page 267.

Example: When a keyword is used for a special value that is expressed as a constant in a context where the keyword could be interpreted as a name, the DECFLOAT function can be used to explicitly cast the value to decimal-floating point. Assume that MYTAB contains columns C1 and SNAN, and that you want to reference the decimal floating-point value for infinity in the same SQL statement. Use the DECFLOAT function to explicitly cast SNAN as a decimal floating-point value to ensure that it is not interpreted as the name of a column, parameter or variable:

```
SELECT INFINITY          -- column named SNAN
FROM MYTAB
WHERE C1 = DECFLOAT ('sNaN' ) -- comparison is made with the
                               -- decimal floating-point sNaN value
```

DECFLOAT_FORMAT scalar function

The DECFLOAT_FORMAT function returns a DECFLOAT(34) value that is based on the interpretation of the input string using the specified format.

► DECFLOAT_FORMAT (— *string-expression* , — *format-string*) ►

The schema is SYSIBM.

string-expression

An expression that returns a value that is a CHAR and VARCHAR data type. If a supplied argument is a GRAPHIC or VARGRAPHIC data type, it is first converted to VARCHAR before evaluating the function. Leading and trailing blanks are removed from the string. If *format-string* is not specified, the resulting substring must conform to the rules for forming an SQL integer, decimal, floating-point, or decimal floating-point constant and not be greater than 42 bytes. Otherwise, the resulting substring must contain the components of a number that corresponds to the format specified by *format-string*.

format-string

An expression that returns a value that is a built-in character string data type. If a supplied argument is a graphic string (except DBCLOB), it is first converted to a character string before the function is evaluated. The actual length must not be greater than 254 bytes.

The value is a template for how *string-expression* is to be interpreted for conversion to a DECFLOAT value. *format-string* must contain a valid combination of the listed format elements according to the following rules:

- At least one '0' or '9' format element must be specified.
- A sign format element ('S', 'MI', 'PR') can be specified only one time.
- A decimal point format element can be specified only one time.
- Alphabetic format elements must be specified in upper case.
- A prefix format element can only be specified at the beginning of the format string, before any format elements that are not prefix format elements. When multiple prefix format elements are specified they can be specified in any order.
- A suffix format element can only be specified at the end of the format string, after any format elements that are not suffix format elements.
- A comma format element can be the first format element that is not a prefix format element. There can be any number of comma format elements.
- Blanks must not be specified between format elements. Leading and trailing blanks can be specified but are ignored.

Table 70. Format elements for the DECFLOAT_FORMAT function

Format element	Description
0 or 9	Each 0 or 9 represents a digit.
S	Prefix If <i>string-expression</i> represents a negative number, a leading minus sign (-) is expected at the specified location. If <i>string-expression</i> represents a positive number, a leading plus sign (+) or leading blank can be included at the specified location.
\$	Prefix A leading dollar sign ('\$') is expected at the specified location.
MI	Suffix If <i>string-expression</i> represents a negative number, a trailing minus sign (-) is expected at the specified location. If <i>string-expression</i> represents a positive number, a trailing blank can be included at the specified location.
PR	Suffix If <i>string-expression</i> represents a negative number, a leading less than character (<) and a trailing greater than character (>) are expected. If <i>string-expression</i> represents a positive number, a leading blank and a trailing blank can be included.
,	Represents a group separator. A group separator is expected at the specified location if there is a character to the left of it that is not a prefix character.
.	A period represents a decimal point that is expected at the specified location.

If *format-string* is not specified, *string-expression* must conform to the rules for forming an SQL integer, decimal, floating-point, or decimal floating-point constant and have a length not greater than 42 bytes.

The result is a DECFLOAT(34).

The result can be null; if any argument is null, the result is the null value.

Notes

Syntax alternatives:

TO_NUMBER is a synonym for DECFLOAT_FORMAT.

Examples

Table 71. Examples of DECFLOAT_FORMAT

Example	Result
DECFLOAT_FORMAT('123.45')	123.45

Table 71. Examples of DECFLOAT_FORMAT (continued)

Example	Result
DECFLOAT_FORMAT('-123456.78')	-123456.78
DECFLOAT_FORMAT('+123456.78')	123456.78
DECFLOAT_FORMAT('1.23E4')	12300
DECFLOAT_FORMAT('123.4', '9999.99')	123.40
DECFLOAT_FORMAT('001,234', '000,000')	1234
DECFLOAT_FORMAT('1234', '9999MI')	1234
DECFLOAT_FORMAT('1234-', '9999MI')	-1234
DECFLOAT_FORMAT('+1234', 'S9999')	1234
DECFLOAT_FORMAT('-1234', 'S9999')	-1234
DECFLOAT_FORMAT(' 1234 ', '9999PR')	1234
DECFLOAT_FORMAT('<1234>', '9999PR')	-1234
DECFLOAT_FORMAT('\$123,456.78', '\$999,999.99')	123456.78

DECFLOAT_SORTKEY scalar function

The DECFLOAT_SORTKEY function returns a binary value that can be used when sorting DECFLOAT values. The sorting occurs in a manner that is consistent with the IEEE 754R specification on total ordering.

►► DECFLOAT_SORTKEY(*decfloat-expression*) ◄◄

The schema is SYSIBM.

decfloat-expression

An expression that returns a DECFLOAT value.

decfloat-expression can also be a character string or graphic string data type. The string input is implicitly cast to a numeric value of DECFLOAT(34).

The result is a fixed length binary string with a length attribute of 9 if *decfloat-expression* is a DECFLOAT(16) value or 17 if *decfloat-expression* is a DECFLOAT(34) value.

The result can be null; if the argument is null, the result is the null value.

Example: Assume that the following CREATE TABLE statement is used to create a table with a column that contains DECFLOAT values and the INSERT statements are used to populate the table:

```
CREATE TABLE T1(D1 DECFLOAT(16));
INSERT INTO T1 VALUES (2.100);
INSERT INTO T1 VALUES (2.10);
INSERT INTO T1 VALUES (2.1000);
INSERT INTO T1 VALUES (2.1);
```

Then the following SELECT statement is used to return the values from D1:

```
SELECT D1 FROM T1 ORDER BY D1;
```

The SELECT statement returns the following values, but because all numbers in the column have the same value, the ORDER BY clause has no effect and the values are returned in an arbitrary order:

```
D1
-----
2.1
2.1000
2.10
2.100
```

The following SELECT statement, which includes the DECFLOAT_SORTKEY function in the ORDER BY clause, returns the properly ordered values:

```
SELECT D1
FROM T1
ORDER BY (DECFLOAT_SORTKEY(D1));
```

```
D1
-----
2.1000
2.100
2.10
2.1
```

DECIMAL or DEC scalar function

The DECIMAL function returns a decimal representation of either a number or a character-string or graphic-string representation of a number, an integer, or a decimal number.

Numeric to Decimal:

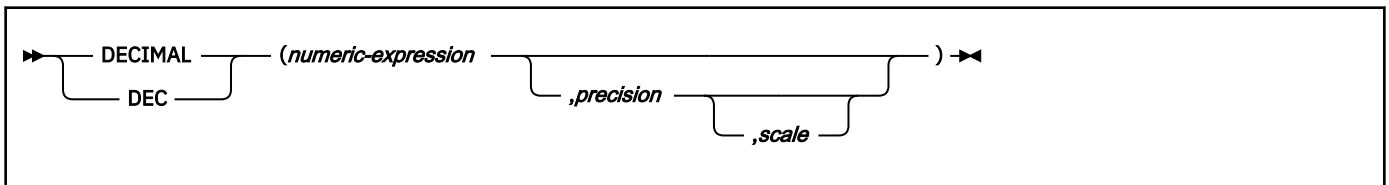

String to Decimal:

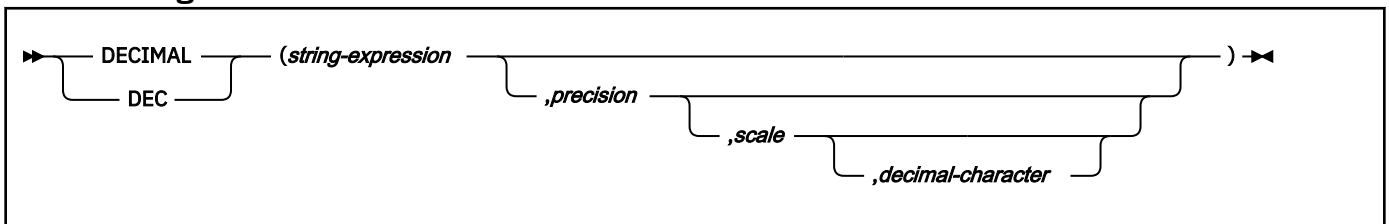

The schema is SYSIBM.

Numeric to decimal

numeric-expression

An expression that returns a value of any built-in numeric data type.

precision

An integer constant with a value greater than or equal to 1 and less than or equal to 31.

The default for *precision* depends on the data type of the *numeric-expression*:

- 5 for small integer
- 11 for large integer
- 19 for big integer
- 15 for floating point or decimal
- 31 for decimal floating point

scale

An integer constant that is greater than or equal to zero and less than or equal to *precision*. The value specifies the scale of the result. The default value is 0.

The result of the function is the same number that would occur if the argument were assigned to a decimal column or variable with precision *p* and scale *s*, where *p* and *s* are specified by the second and third arguments. An error occurs if the number of significant digits required to represent the whole part of the number is greater than $p - s$.

String to decimal***string-expression***

An expression that returns a value of a character or graphic string (except a CLOB or DBCLOB) with a length attribute that is not greater than 255 bytes. The string must contain a valid string representation of a number. Leading and trailing blanks are removed from the string, and the resulting substring must conform to the rules for forming a valid string representation of an SQL integer or decimal constant.

precision

An integer constant with a value in the range 1 to 31. The value of this second argument specifies the precision of the result. If not specified, the default is 15.

scale

An integer constant that is greater than or equal to zero and less than or equal to *precision*. The value specifies the scale of the result. The default value is 0.

decimal-character

A single-byte character constant used to delimit the decimal digits in *string-expression* from the whole part of the number. The character cannot be a digit, plus (+), minus (-), or blank. The default value is period (.) or comma (,); the default value cannot be used in *string-expression* if a different value for *decimal-character* is specified.

Digits are truncated from the end of the decimal number if the number of digits to the right of the decimal separator character is greater than the scale *s*. An error is returned if the number of significant digits to the left of the decimal character (the whole part of the number) in *string-expression* is greater than $p - s$.

The result of the function is a decimal number with precision of *p* and scale of *s*, where *p* and *s* are the second and third arguments. If the first argument can be null, the result can be null; if the first argument is null, the result is null.

Notes**Syntax alternatives:**

To increase the portability of applications when the precision is specified, use the CAST specification. For more information, see [“CAST specification”](#) on page 267.

Examples**Example 1:**

Represent the average salary of the employees in DSN8C10.EMP as an 8-digit decimal number with two of these digits to the right of the decimal point.

```
SELECT DECIMAL(AVG(SALARY),8,2)
FROM DSN8C10.EMP;
```

Example 2:

Assume that updates to the SALARY column are input as a character string that uses comma as the decimal character. For example, the user inputs 21400,50. The input value is assigned to the host variable NEWSALARY that is defined as CHAR(10), and the host variable is used in the following UPDATE statement:

```

UPDATE DSN8C10.EMP
SET SALARY = DECIMAL (:NEWSALARY,9,2,',' )
WHERE EMPNO = :EMPID;

```

DECODE scalar function

The DECODE function compares each *expression2* to *expression1*. If *expression1* is equal to *expression2*, or both *expression1* and *expression2* are null, the value of the *result-expression* is returned. If no *expression2* matches *expression1*, the value of *else-expression* is returned. Otherwise a null value is returned.

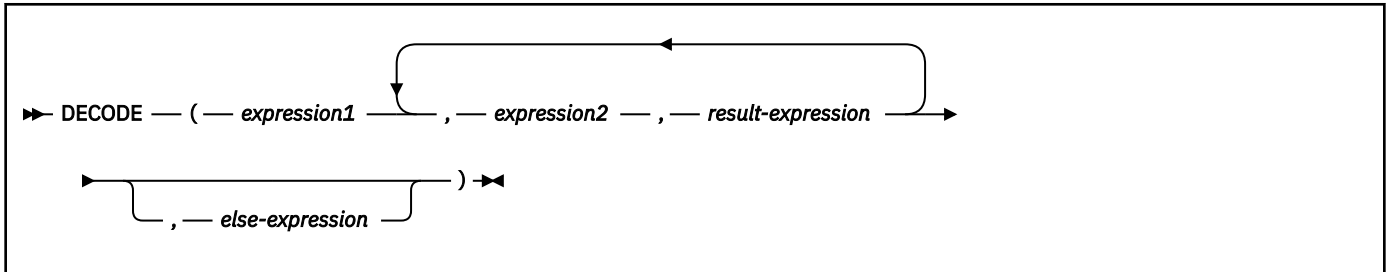

The schema is SYSIBM.

The DECODE function is similar to the CASE expression, with the exception of how DECODE handles null values:

- A null value in *expression1* will match a corresponding null value in *expression2*.
- If the NULL keyword is used as an argument in the DECODE function, it must be cast to a data type that is appropriate for comparison.

An argument of DECODE must not represent an array value.

The rules for determining the result type of the result of the DECODE function are based on the corresponding CASE expression.

The following table shows equivalent DECODE functions and CASE expressions. Both the DECODE function and the corresponding CASE expression achieve the same result.

DECODE function	CASE expression	Notes
DECODE(c1, 7, 'a', 6, 'b', 'c')	CASE c1 WHEN 7 THEN 'a' WHEN 6 THEN 'b' ELSE 'c' END	
DECODE(c1, var1, 'a', var2, 'b')	CASE WHEN c1 = var1 OR (c1 IS NULL AND var1 IS NULL) THEN 'a' WHEN c1 = var2 OR (c1 IS NULL AND var2 IS NULL) THEN 'b' ELSE NULL END	The values of c1, var1, and var2 can be null values.

Table 72. Equivalent DECODE functions and CASE expressions (each returns the same results) (continued)

DECODE function	CASE expression	Notes
<pre>SELECT ID, DECODE(STATUS, 'A', 'Accepted', 'D', 'Denied', CAST(NULL AS VARCHAR(1)), 'Unknown', 'Other') FROM CONTRACTS</pre>	<pre>SELECT ID, CASE WHEN STATUS = 'A' THEN 'Accepted' WHEN STATUS = 'D' THEN 'Denied' WHEN STATUS IS NULL THEN 'Unknown' ELSE 'Other' END FROM CONTRACTS</pre>	

DECRYPT_BINARY, DECRYPT_BIT, DECRYPT_CHAR, and DECRYPT_DB scalar functions

The decryption functions return a value that is the result of decrypting encrypted data. The decryption functions can decrypt only values that are encrypted by using the ENCRYPT_TDES function.

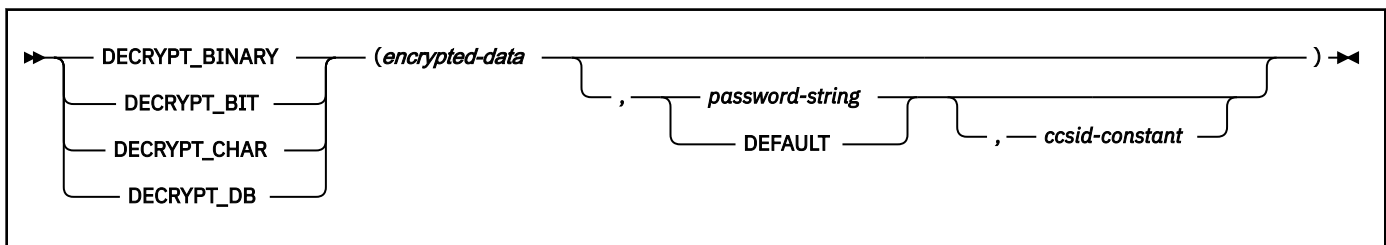

The schema is SYSIBM.

The password used for decryption is either the *password-string* value or the ENCRYPTION PASSWORD value, which is assigned by the SET ENCRYPTION PASSWORD statement.

encrypted-data

An expression that returns a complete, encrypted data value of a CHAR FOR BIT DATA, VARCHAR FOR BIT DATA, BINARY, or VARBINARY data type. The data string must have been encrypted using the ENCRYPT_TDES function. The length attribute must be greater than or equal to 0 (zero) and less than or equal to 32672.

password-string

An expression that returns a CHAR or VARCHAR value with at least 6 bytes and no more than 127 bytes. This expression must be the same password that was used to encrypt the data or decryption will result in a different value than was originally encrypted. For enhanced security, *password-string* should be specified using a host variable rather than a string constant. If the value of the password argument is null or not provided, the data will be decrypted using the ENCRYPTION PASSWORD value, which must have been assigned by the SET ENCRYPTION PASSWORD statement.

For a static SQL statement, it is recommended that the password be specified with a host variable rather than with a string constant.

DEFAULT

The data is decrypted using the ENCRYPTION PASSWORD value, which must have been assigned by the SET ENCRYPTION PASSWORD statement.

ccsid-constant

A integer constant that specifies the CCSID in which the data should be returned by the decryption function. If DECRYPT_BIT or DECRYPT_BINARY is specified, *ccsid-constant* must not be specified. The default is

- The ENCODING bind option of the plan or package or the APPLICATION ENCODING SCHEMA option of the CREATE PROCEDURE or ALTER PROCEDURE statement for native SQL procedures that contain the static SQL statements

- The value of the APPLICATION ENCODING special register for dynamic SQL statements

The data type of the result of the function is determined by the function that is specified and the data type of the first argument, as shown in the following table. If the cast from the actual type of the encrypted data to the result of the function is not supported, a warning or error is returned.

Table 73. Result of the decryption function

Function	Type of first argument	Actual type of encrypted data	Result
DECRYPT_BINARY	FOR BIT DATA “1” on page 445, BINARY, VARBINARY	Any string (except for LOBs)	VARBINARY
DECRYPT_BIT	FOR BIT DATA, BINARY, VARBINARY	CHAR, VARCHAR	VARCHAR FOR BIT DATA
DECRYPT_BIT	FOR BIT DATA, BINARY, VARBINARY	GRAPHIC, VARGRAPHIC (UTF16)	Warning or error If a warning is returned, the result is VARCHAR FOR BIT DATA
DECRYPT_BIT	FOR BIT DATA, BINARY, VARBINARY	GRAPHIC, VARGRAPHIC (not UTF16)	Warning or error If a warning is returned, the result is VARCHAR FOR BIT DATA
DECRYPT_BIT	FOR BIT DATA, BINARY, VARBINARY	BINARY, VARBINARY	Warning or error If a warning is returned, the result is VARCHAR FOR BIT DATA
DECRYPT_CHAR	FOR BIT DATA, BINARY, VARBINARY	CHAR, VARCHAR	VARCHAR(3)
DECRYPT_CHAR	FOR BIT DATA, BINARY, VARBINARY	GRAPHIC, VARGRAPHIC (UTF16)	VARCHAR(3)
DECRYPT_CHAR	FOR BIT DATA, BINARY, VARBINARY	GRAPHIC, VARGRAPHIC (not UTF16)	Warning or error If a warning is returned, the result is VARCHAR(3)
DECRYPT_CHAR	FOR BIT DATA, BINARY, VARBINARY	BINARY, VARBINARY	Warning or error If a warning is returned, the result is VARCHAR(3)
DECRYPT_DB	FOR BIT DATA, BINARY, VARBINARY	CHAR, VARCHAR, GRAPHIC, VARGRAPHIC	VARGRAPHIC
DECRYPT_DB	FOR BIT DATA, BINARY, VARBINARY	BINARY, VARBINARY	Warning or error If a warning is returned, the result is VARGRAPHIC

Notes:

1. FOR BIT DATA means CHAR or VARCHAR FOR BIT DATA

If *encrypted-data* included a hint, the hint is not returned by the function. The length attribute of the result is the length attribute of *encrypted-data* minus 8 bytes. The actual length of the value that is returned by the function will match the length of the original string that was encrypted. If *encrypted-data* includes bytes beyond the encrypted string, these bytes are not returned by the function.

Administration of encrypted data: The decryption functions can only decrypt data that was encrypted using the Triple DES encryption algorithm. Therefore, columns with encrypted data can only be used after replication if they were encrypted using the Triple DES encryption algorithm.

If the data is decrypted using a different CCSID than the originally encrypted value, it is possible that expansion might occur when converting the decrypted value to this CCSID. In such situations, the *encrypted-data* value must first be cast to a VARCHAR string with a larger number of bytes before performing the decryption functions.

The result can be null; if the first argument is null, the result is the null value.

For additional information about using the decryption functions, see [“ENCRYPT_TDES or ENCRYPT scalar function” on page 456](#) and [“GETHINT scalar function” on page 463](#).

Password protection: To prevent inadvertent access to the encryption password, do not specify *password-string* as a string constant in the source statement. Instead, use the ENCRYPTION PASSWORD special register or specify the password using a host variable.

Example 1: Set the ENCRYPTION PASSWORD value to 'Ben123' and use it as the password to insert a decrypted social security number into the table. Decrypt the value of the added social security number, using the ENCRYPTION PASSWORD value.

```
SET ENCRYPTION PASSWORD = 'Ben123' ;
INSERT INTO EMP(SSN) VALUES ENCRYPT_TDES('289-46-8832') ;
SELECT DECRYPT_CHAR(SSN) FROM EMP;
```

This example returns the value '289-46-8832'.

Example 2: Decrypt the social security number that is inserted into the table. Instead of using the ENCRYPTION PASSWORD value, explicitly specify 'Ben123' as the encryption password.

```
SELECT DECRYPT_CHAR(SSN, 'Ben123') FROM EMP;
```

This example returns the value '289-46-8832'.

Example 3: Insert a decrypted social security number into the table, explicitly specifying 'Ben123' as the password. Decrypt the data and have it converted to CCSID 1208.

```
SET ENCRYPTION PASSWORD = 'Ben123' ;
INSERT INTO EMP(SSN) VALUES ENCRYPT_TDES('289-46-8832') ;
SELECT DECRYPT_CHAR(SSN) FROM EMP;
```

When a CCSID is specified, it might be necessary to explicitly cast the data to a longer value to ensure that there is room for expansion when the data is decrypted. The following example illustrates the technique:

```
SELECT DECRYPT_CHAR(CAST(SSN AS VARCHAR(57)),
                  'Ben123',1208)
FROM EMP;
```

In the first case, where the data is not cast to a longer value, the result is a VARCHAR(11) value. In the second case, to allow for expansion, SSN is cast as VARCHAR(57) ($11 * 3 + 24$). Casting the data to a longer value allows for three times expansion in the normal VARCHAR(11) result. Three times expansion is often associated with a worst case of ASCII or EBCDIC to Unicode UTF-8 conversion. In both cases in this example, the result is the VARCHAR(11) value '289-46-8832'.

DECRYPT_DATAKEY_INTEGER, DECRYPT_DATAKEY_BIGINT, DECRYPT_DATAKEY_DECIMAL, DECRYPT_DATAKEY_VARCHAR,

DECRYPT_DATAKEY_CLOB, DECRYPT_DATAKEY_VARGRAPHIC, DECRYPT_DATAKEY_DBCLOB, and DECRYPT_DATAKEY_BIT scalar functions

The data key decryption functions return a value that is the result of decrypting the first argument (previously encrypted using the ENCRYPT_DATAKEY function) using the algorithm that was specified when the data was encrypted. The name of the decryption function indicates the desired result data type. The name of the decryption function that is invoked must correspond to the original data type of the encrypted data.

[FL 505](#)

Authorization

The primary authorization ID that is used to invoke the decrypt function must be authorized to use the key label that was used to encrypt the data. The key label is saved in the metadata stored with the encrypted value, so the key label does not need to be specified during decryption. When no ACEE is available for the primary authorization ID, Db2 creates one to check for the required authorization when the decrypt function executes. For more information, see [When Db2 creates an ACEE \(RACF Access Control Module Guide\)](#).

Syntax

Integer:

```

DECRYPT_DATAKEY_INTEGER (encrypted-data)
DECRYPT_DATAKEY_BIGINT (encrypted-data)
  
```

Decimal:

```

DECRYPT_DATAKEY_DECIMAL (encrypted-data , precision , scale )
  
```

String:

```

DECRYPT_DATAKEY_VARCHAR (encrypted-data , ccsid-constant )
DECRYPT_DATAKEY_CLOB (encrypted-data)
DECRYPT_DATAKEY_VARGRAPHIC (encrypted-data)
DECRYPT_DATAKEY_DBCLOB (encrypted-data)
  
```

Bit:

```

DECRYPT_DATAKEY_BIT (encrypted-data)
  
```

The schema is SYSIBM.

encrypted-data

An expression that returns a built-in VARBINARY or BLOB value. The value must be returned in the same format that the ENCRYPT_DATAKEY function returns.

ccsid-constant

An integer constant that specifies the CCSID in which the data should be returned by the decryption function. The value must be one of the CCSID values in DECP. If the result of the function is VARCHAR, the CCSID specified must be either an SBCS or MIXED CCSID. If the result of the function is CLOB, the CCSID specified must be a MIXED CCSID if the encoding scheme is Unicode; otherwise the CCSID specified must be an SBCS or MIXED CCSID. If the result of the function VARGRAPHIC or DBCLOB, the CCSID specified must be a DBCS CCSID. See [Determining the encoding scheme and CCSID of a string \(Introduction to Db2 for z/OS\)](#) for special considerations regarding CCSID 367.

If *ccsid* is not specified when *encrypted-data* is a character or graphic string, the default is determined from the encoding scheme and the data type of the result as follows:

- For static SQL statements, the ENCODING bind option of the plan or package or the APPLICATION ENCODING SCHEME option of the CREATE or ALTER statement for a compiled SQL scalar function, native SQL procedure, or advanced trigger.
- For dynamic SQL statements, the value of the APPLICATION ENCODING special register.

The default CCSID of the result is determined from the result data type:

- VARCHAR: the default result CCSID is the mixed data CCSID for the encoding scheme.
- CLOB: the default result CCSID is the mixed data CCSID for the encoding scheme.
- VARGRAPHIC or DBCLOB: the default result CCSID is the DBCS CCSID for the encoding scheme.

precision

An integer constant with a value greater than or equal to 1 and less than or equal to 31.

scale

An integer constant that is greater than or equal to zero and less than or equal to *precision*. The value specifies the scale of the result.

The data type of the result of the function is determined by the name of the decryption function that is invoked. The name of the decryption function must indicate the data type of the original value that was encrypted by the ENCRYPT_DATAKEY function.

Table 74. Data key decryption functions and the data type of the result

Function	Data type of the first argument	Original data type of the encrypted data	Data type of the result of the function
DECRYPT_DATAKEY_INTEGER	VARBINARY	INTEGER	INTEGER
DECRYPT_DATAKEY_BIGINT	VARBINARY	BIGINT	BIGINT
DECRYPT_DATAKEY_DECIMAL	VARBINARY	DECIMAL	DECIMAL (<i>precision, scale</i>)
DECRYPT_DATAKEY_BIT	VARBINARY	CHAR FOR BIT DATA, VARCHAR FOR BIT DATA	VARCHAR FOR BIT DATA
DECRYPT_DATAKEY_VARCHAR	VARBINARY	CHAR, VARCHAR	VARCHAR
DECRYPT_DATAKEY_CLOB	BLOB	CLOB	CLOB
DECRYPT_DATAKEY_VARGRAPHIC	VARBINARY	GRAPHIC, VARGRAPHIC	VARGRAPHIC
DECRYPT_DATAKEY_DBCLOB	BLOB	DBCLOB	DBCLOB

The length attribute of the result is the length attribute of the data type of *encrypted-data* minus 8 bytes. If a function returns a string data type, the length attribute of the result is the length attribute of the data type of *encrypted-data* minus 16 bytes. The actual length of the result is the length of the original string that was encrypted. If the *encrypted-data* includes bytes beyond the encrypted string, these bytes are not returned by the function.

If the first argument is null, the result can be null; if the first argument is null, the result is the null value.

If the result data type is a string, the encrypted data is decrypted to the original CCSID, and then the intermediate result is cast to the specified CCSID for the result. If the result data type is VARCHAR FOR BIT DATA, the CCSID of the result is 65535. Otherwise, if the result data type is VARCHAR, CLOB, DBCLOB, or VARGRAPHIC, the CCSID of the result is *ccsid*. If the data is decrypted using a different CCSID than the originally encrypted value, it is possible that expansion might occur when converting the decrypted value to this CCSID. In such situations, the *encrypted-data* value must first be cast to a varying-length string with a larger number of bytes before performing the decryption.

Example

Decrypt the value in the PROTECTED_SSN VARBINARY column. The encrypted data was originally a character string.

```
SELECT DECRYPT_DATAKEY_VARCHAR(PROTECTED_SSN)
FROM CUSTOMER
WHERE CID = ?
```

The CCSID for the result was not specified, so it defaults as described for the *ccsid* parameter.

Related tasks

Defining columns for data encrypted using the ENCRYPT_DATAKEY built-in function. ([Managing Security](#))

Related reference

ENCRYPT_DATAKEY scalar function

The ENCRYPT_DATAKEY function returns a value that is the result of encrypting the first argument using the specified key label and algorithm.

DEGREES scalar function

The DEGREES function returns the number of degrees of the argument, which is an angle, expressed in radians.

►► DEGREES(*numeric-expression*) ◄◄

The schema is SYSIBM.

The argument must be an expression that returns the value of any built-in numeric data type that is not DECFLOAT. If the argument is not a double precision floating-point number, it is converted to one for processing by the function.

The result of the function is a double precision floating-point number.

The result can be null; if the argument is null, the result is the null value.

Example: Assume that host variable HRAD is a DOUBLE with a value of 3.1415926536. The following statement returns a double precision floating-point number with an approximate value of 180.0.

```
SELECT DEGREES(:HRAD)
FROM SYSIBM.SYSDUMMY1;
```

DIFFERENCE scalar function

The DIFFERENCE function returns a value, in the range 0–4, that represents the difference between the sounds of two strings, based on applying the SOUNDEX function to the strings. A value of 4 is the best possible sound match.

►► DIFFERENCE(*expression-1* , *expression-2*) ◄◄

The schema is SYSIBM.

expression-1* or *expression-2

Each expression must return a value that is a built-in numeric, character string, or graphic string data type that is not a LOB. A numeric argument is cast to a character string before the function is evaluated. For more information on converting a numeric string to a character string, see [“VARCHAR scalar function” on page 615](#).

The data type of the result is INTEGER.

The result can be null; if any argument is null, the result is the null value.

Example 1: Find the DIFFERENCE and SOUNDEX values for 'CONSTRAINT' and 'CONSTANT':

```
SELECT DIFFERENCE('CONSTRAINT' , 'CONSTANT') ,
       SOUNDEX('CONSTRAINT') ,
       SOUNDEX('CONSTANT')
FROM SYSIBM.SYSDUMMY1;
```

This example returns the values 4, C523, and C523. Since the two strings return the same SOUNDEX value, the difference is 4 (the highest value possible).

Example 2: Find the DIFFERENCE and SOUNDEX values for 'CONSTRAINT' and 'CONTRITE':

```
SELECT DIFFERENCE('CONSTRAINT' , 'CONTRITE') ,
       SOUNDEX('CONSTRAINT') ,
       SOUNDEX('CONTRITE')
FROM SYSIBM.SYSDUMMY1;
```

This example returns the values 2, C523, and C536. In this case, the two strings return different SOUNDEX values, and hence, a lower difference value.

DIGITS scalar function

The DIGITS function returns a character string representation of the absolute value of a number.

►► DIGITS(*numeric-expression*) ◄◄

The schema is SYSIBM.

The argument must be an expression that returns a value that is a SMALLINT, INTEGER, BIGINT, or DECIMAL built-in numeric data type.

The result of the function is a fixed-length character string representing the absolute value of the argument without regard to its scale. The result does not include a sign or a decimal point. Instead, it consists exclusively of digits, including, if necessary, leading zeros to fill out the string. The length of the string is:

- 5 if the argument is a small integer
- 10 if the argument is a large integer
- 19 if the argument is a big integer
- *p* if the argument is a decimal number with a precision of *p*

The result can be null; if the argument is null, the result is the null value.

The CCSID of the result is determined from the context in which the function was invoked. For more information, see [Determining the encoding scheme and CCSID of a string](#) (Introduction to Db2 for z/OS).

Example 1: Assume that an INTEGER column called INTCOL containing a 10-digit number is in a table called TABLEX. INTCOL has the data type INTEGER instead of CHAR(10) to save space. the following query lists all combinations of the first four digits in column INTCOL.

```
SELECT DISTINCT SUBSTR(DIGITS(INTCOL),1,4)
FROM TABLEX;
```

Example 2: Assume that COLUMNX has the data type DECIMAL(6,2), and that one of its values is -6.28. For this value, the following statement returns the value '000628'.

```
DIGITS(COLUMNX)
```

The result is a string of length six (the precision of the column) with leading zeros padding the string out to this length. Neither sign nor decimal point appear in the result.

DOUBLE_PRECISION or DOUBLE scalar function

The DOUBLE_PRECISION and DOUBLE functions returns a floating-point representation of either a number or a character-string or graphic-string representation of a number, an integer, a decimal number, or a floating-point number.

Numeric to Double:

```
DOUBLE_PRECISION (numeric-expression)
DOUBLE (numeric-expression)
```

String to Double:

```
DOUBLE_PRECISION (string-expression)
DOUBLE (string-expression)
```

The schema is SYSIBM.

Numeric to Double

numeric-expression

An expression that returns a value of any built-in numeric data type.

The result is the same number that would occur if the expression were assigned to a double precision floating-point column or variable.

String to Double

string-expression

An expression that returns a value of a character or graphic string (except a CLOB or DBCLOB) with a length attribute that is not greater than 255 bytes. The string must contain a valid string representation of a number.

The result is the same number that would result from `CAST(string-expression AS DOUBLE PRECISION)`. Leading and trailing blanks are removed from the string, and the resulting substring must conform to the rules for forming a valid string representation of an SQL floating-point, integer, or decimal constant.

The result of the function is a double precision floating-point number.

The result can be null; if the argument is null, the result is the null value.

Notes

Syntax alternatives:

FLOAT is a synonym for DOUBLE or DOUBLE_PRECISION.

To increase the portability of applications, use the CAST specification. For more information, see [“CAST specification”](#) on page 267.

Example

Using sample table DSN8C10.EMP, find the ratio of salary to commission for employees whose commission is not zero. The columns involved in the calculation, SALARY and COMM, have decimal data types. To eliminate the possibility of out-of-range results, apply the DOUBLE function to SALARY so that the division is carried out in floating-point.

```
SELECT EMPNO, DOUBLE(SALARY)/COMM
FROM DSN8C10.EMP
WHERE COMM > 0;
```

DSN_XMLVALIDATE scalar function

The DSN_XMLVALIDATE function returns an XML value that is the result of applying XML schema validation to the first argument of the function. DSN_XMLVALIDATE can validate XML data that has a maximum length of 2 GB - 1 byte.

► DSN_XMLVALIDATE(*string-expression* , *schema-name-string*) ◄
xml-expression , *target-namespace-uri-string* , *schema-location-string*

The schema is SYSIBM.

string-expression

An expression that returns a built-in character, graphic, or binary string. The value must be a well-formed XML document that conforms to the XML Version 1.0 standard.

xml-expression

An expression that returns an XML value in the XML data type. The value must be a well-formed XML document that conforms to XML Version 1.0 standard.

schema-name-string

An expression that returns a built-in varying length character string that is not a CLOB. The value specifies the name of the XML schema object that is used for validation. The value must not be an empty string or the null value, and the actual length must be less than or equal to 257. If the XML schema name is qualified, the qualifier must be SYSXSR (SYSXSR is the default qualifier). The value must identify a registered XML schema in the Db2 XML schema repository.

target-namespace-uri-string

An expression that returns a built-in varying length character string that is not a CLOB, with a length attribute that is not greater than 1000. The value specifies the target namespace name or universal resource identifier (URI) of the XML schema that is to be used for validation. If the value is an empty string or the null value, no namespace is used to locate the XML schema.

schema-location-string

An expression that returns a built-in varying length character string that is not a CLOB, with a length attribute that is not greater than 1000. The value specifies the XML schema location hint URI of the XML schema that is to be used for validation. If the value is an empty string or the null value, no schema location is used to locate the XML schema.

If *target-namespace-uri-string* and *schema-location-string* are specified, the combination must identify a registered XML schema in the Db2 XML schema repository, and there must be only one such registered XML schema.

A schema must be registered successfully in the Db2 XML schema repository before it can be used for DSN_XMLVALIDATE. If the validation fails, Db2 returns an error.

The result of the function is an XML value.

The result can be null; if the first argument is null, the result is the null value.

Example 1: The following example shows how the DSN_XMLVALIDATE function validates the XML data that is contained in the *value_host_var* host variable. The XML schema, SYSXSR.ORDERSCHEMA, was registered prior to this statement:

```
INSERT INTO T1(C1) VALUES(  
    DSN_XMLVALIDATE(:value_host_var, 'SYSXSR.MYXMLSCHEMA'));
```

Example 2: The following example is similar to the previous example but references the namespace and schema location:

```
INSERT INTO T1(C1) VALUES(  
    DSN_XMLVALIDATE(:value_host_var,  
                    'http://www.n1.com',  
                    'http://www.n1.com/report.xsd'));
```

EBCDIC_CHR scalar function

The EBCDIC_CHR function returns the character that has the EBCDIC code value that is specified by the argument.

►► EBCDIC_CHR(*expression*) ◄◄

The schema is SYSIBM.

expression

An expression that returns a BIGINT, INTEGER, or SMALLINT built-in data type value.

expression can also be a character string or graphic string data type. The string input is implicitly cast to a numeric value of DECFLOAT(34) which is then assigned to a BIGINT value.

The result of the function is a CHAR(1) string encoded in the SBCS EBCDIC CCSID (regardless of the setting of the MIXED option in DSNHDECP). If the value of *expression* is not in the range 0–255, the null value is returned.

The result can be null; if the argument is null, the result is the null value.

Example: Set *hv* with the Euro symbol "€" in CCSID 1140:

```
SET :hv = EBCDIC_CHR(159); -- x'9F'
```

Set *hv* with the Euro symbol "€" in CCSID 1142:

```
SET :hv = EBCDIC_CHR(90); -- x'5A'
```

In both cases, the "€" is assigned to *hv*, but because the Euro symbol is located at different code points for the two CCSIDs, the input value is different.

EBCDIC_STR scalar function

The EBCDIC_STR function returns a string, in the system EBCDIC CCSID, that is an EBCDIC version of the string.

►► EBCDIC_STR(*string-expression*) ◄◄

The schema is SYSIBM.

The system EBCDIC CCSID is defined as the SBCS EBCDIC CCSID on a MIXED=NO system or the MIXED EBCDIC CCSID on a MIXED=YES system.

string-expression

An expression that returns a value of a built-in character or graphic string. If the string is a character string, it cannot be bit data. *string-expression* must be an ASCII, EBCDIC, or Unicode string. EBCDIC_STR returns an EBCDIC version of the string. Non-EBCDIC characters other than the Unicode replacement character (X'EFBFBD' in UTF-8 encoding or X'FFFD' in UTF-16 encoding), are converted to the form \xxxx, where xxxx represents a UTF-16 code unit. The Unicode replacement character is converted to X'3F'.

The argument can also be a numeric data type. The numeric argument is implicitly cast to a VARCHAR data type.

The length attribute of the result is calculated using the formulas in [Table 37 on page 163](#). The length attribute of the result will be $\text{MIN}(\text{length} - 5 * n, 32704)$. Where *n* is the result of applying the formulas in [Table 37 on page 163](#) based on input and output data types.

The result of the function is an EBCDIC character string (in the system EBCDIC CCSID). If the actual length of the result string exceeds the maximum for the return type, an error occurs.

The result can be null; if the argument is null, the result is the null value.

Example: The following example returns the EBCDIC string equivalent of the text string "Hi my name is Андрей (Andrei)"

```
SET :HV1 = EBCDIC_STR('Hi, my name is Андрей (Andrei)');
```

HV1 is assigned the value "Hi, my name is \0410\043D\0434\0440\0435\0439 (Andrei)"

ENCRYPT_DATAKEY scalar function

The ENCRYPT_DATAKEY function returns a value that is the result of encrypting the first argument using the specified key label and algorithm.

Authorization

The primary authorization ID used to invoke the ENCRYPT_DATAKEY function must be authorized to use the key label that is specified in *key-label-name*. Authorization for use of the key label is checked when the function is invoked. When no ACEE is available for the primary authorization ID, Db2 creates one to check for the required authorization when the ENCRYPT_DATAKEY function executes. For more information, see [When Db2 creates an ACEE \(RACF Access Control Module Guide\)](#).

[FL 505](#)

Syntax

```
► ENCRYPT_DATAKEY( expression, key-label-name ,  ) ►
```

The schema is SYSIBM.

expression

An expression that contains the data to be encrypted. The expression must return an INTEGER, BIGINT, DECIMAL, CHAR, VARCHAR, GRAPHIC, VARGRAPHIC, CLOB, or DBCLOB built-in data type.

key-label-name

An expression that contains the ICSF key label name.

A key label is the public name of a protected key and it must be defined in the ICSF key store. The primary authorization ID used to invoke the ENCRYPT_DATAKEY function must be authorized to use the key label.

AES256R

Specifies that the 256-bit AES CBC algorithm with a random initialization vector (IV) is used to encrypt the data. This algorithm results in a non-deterministic encrypted value and provides the highest level of protection.

A non-deterministic encrypted value is returned for every input value. The resulting text strings cannot be compared even when the encrypted values to be compared originated from the same unencrypted value. An encrypted value must be decrypted before using it in a comparison.

AES256D

Specifies that the 256-bit AES CBC algorithm with a fixed initialization vector (IV) will be used to encrypt the data. This algorithm results in a deterministic encrypted value. The resulting text value can be used in equal comparisons against the encrypted text strings. Identical input values encrypted using this mode all result in the same encrypted value. Equality comparisons can be performed on the encrypted values without decrypting the values.

The data type of the result is determined by the first argument as shown in the following table:

Table 75. Data type of the results of the ENCRYPT_DATAKEY function

Data type of the first argument	Data type of the result
BIGINT, INTEGER, DECIMAL, CHAR, VARCHAR, GRAPHIC, VARGRAPHIC	VARBINARY
CLOB, DBCLOB	BLOB

The length attribute and actual length of the result are determined as follows:

- Length attribute of result in bytes = $((\text{length attribute of source data in bytes} + 16 - 1) / 16) * 16 + 15\text{-byte fixed header} + 64\text{ bytes for length attribute of key label}$.
- Actual length of result in bytes = $((\text{actual length of source data in bytes} + 16 - 1) / 16) * 16 + 15\text{-byte fixed header} + \text{variable length key label in bytes}$. If *expression* is an empty string, the actual length of the result in bytes = 15-byte fixed header + variable length key label in bytes.

The actual length of the result can be longer than the length of *expression*. Therefore, when assigning a resulting encrypted value, ensure that the target is defined with a length attribute that can contain the entire encrypted value.

The result can be null; if *expression* is null, the result is the null value.

Notes

Administration of encrypted data

A replicated server must have access to the same security label and same decryption function for Db2 to be able to decrypt the data.

If AES256R is specified, the ENCRYPT_DATAKEY function is a non-deterministic function.

If AES256R and AES256D are mixed within the same column or a different key label is used for each row, the encrypted values must be decrypted before being used in any sort of comparison.

Example

Encrypt the values in the character column SSN and insert the resulting values into the PROTECTED_SSN column in the CUSTOMER table: The PROTECTED_SSN column is defined as VARBINARY. Use 'MYKEYLABEL' as the key label, and the AES256D encryption algorithm.

```
UPDATE CUSTOMER
SET PROTECTED_SSN = ENCRYPT_DATAKEY(SSN, 'MYKEYLABEL', AES256D);
```

Related tasks

Defining columns for data encrypted using the ENCRYPT_DATAKEY built-in function. (Managing Security)

Related reference

DECRYPT_DATAKEY_type

The data key decryption functions return a value that is the result of decrypting the first argument (previously encrypted using the ENCRYPT_DATAKEY function) using the algorithm that was specified when the data was encrypted. The name of the decryption function indicates the desired result data type. The name of the decryption function that is invoked must correspond to the original data type of the encrypted data.

ENCRYPT_TDES or ENCRYPT scalar function

The ENCRYPT_TDES function returns a value that is the result of encrypting the first argument by using the Triple DES encryption algorithm. The function can also set the password that is used for encryption.

The encryption password can also be set by using the ENCRYPTION PASSWORD value, which is assigned by using the SET ENCRYPTION PASSWORD statement.

```
►► ENCRYPT_TDES( data-string , — password-string , — hint-string ) ►►
```

The schema is SYSIBM.

data-string

An expression that returns the string value to be encrypted. The string expression must return a built-in string data type that is not a LOB. The length attribute must be greater than or equal to 0 (zero). The length attribute is limited to 32640 if *hint-string* is specified and 32672 if *hint-string* is not specified.

The argument can also be a numeric data type. The numeric argument is implicitly cast to a VARCHAR data type.

password-string

An expression that returns a CHAR or VARCHAR value with at least 6 bytes and no more than 127 bytes.

The argument can also be a numeric data type. The numeric argument is implicitly cast to a VARCHAR data type.

The value represents the password that is used to encrypt *data-string*. If the value of the password argument is null or not specified, the data is encrypted using the ENCRYPTION PASSWORD value, which must have been assigned by the SET ENCRYPTION PASSWORD statement.

hint-string

An expression that returns a CHAR or VARCHAR value up to 32 bytes that is to help data owners remember passwords (for example, 'Ocean' as a hint to remember 'Pacific').

The argument can also be a numeric data type. The numeric argument is implicitly cast to a VARCHAR data type.

If a hint value is specified, the hint is embedded into the result and can be retrieved using the GETHINT function. If this argument is null or not specified and no hint was specified when the ENCRYPTION PASSWORD was set, no hint is embedded in the result. If *password-string* is not specified, the hint can be specified using the SET ENCRYPTION PASSWORD statement.

The data type of the result is determined by the first argument as shown in the following table:

Table 76. Data type of the results of the ENCRYPT_TDES function

Data type of the first argument	Data type of the result
BINARY, VARBINARY	VARBINARY
CHAR, VARCHAR, GRAPHIC, VARGRAPHIC	VARCHAR FOR BIT DATA

The encoding scheme of the result is the same as the encoding scheme of *data-string*. If the result is character data, the result is bit data.

The length attribute of the result is different depending of whether *hint-string* is specified:

- If *hint-string* is specified, the length attribute of the result is the length attribute of the non-encrypted data + 24 bytes + number of bytes to the next 8 byte boundary + 32 bytes for the hint.
- If *hint-string* is not specified, the length attribute of the result is the length attribute of the non-encrypted data + 24 bytes + the number of bytes to the next 8 byte boundary.

The result can be null; if the first argument is null, the result is the null value.

The encrypted result is longer than the *data-string* value. Therefore, when assigning encrypted values, ensure that the target is declared with a length that can contain the entire encrypted value.

Notes

Data encryption considerations:

Password protection

To prevent inadvertent access to the encryption password, do not specify *password-string* as a string constant in the source for a program, procedure, or function. Instead, use the SET ENCRYPTION PASSWORD statement or a variable.

Encryption algorithm:

The internal encryption algorithm used is Triple DES cipher block chaining (CBC) with padding. The 128-bit secret key is derived from the password using an MD5 hash.

Encryption passwords and data

It is your responsibility to perform password management. After data is encrypted, only the password that is used to encrypt it can be used to decrypt it. If a different password is used to decrypt the data than was used to encrypt the data, the results of decryption will not match the original string. No error or warning is returned. CHAR variables might be padded with blanks if they are used to set password values. The encrypted result might contain null terminator and other non-printable characters.

Table column definitions

When defining columns and types to contain encrypted data, always calculate the length attribute as follows:

- For encrypted data with an embedded hint, the column length should be the length attribute of the non-encrypted data + 24 bytes + number of bytes to the next 8 byte boundary + 32 bytes for the hint.
- For encrypted data without an embedded hint, the column length should be the length attribute of the non-encrypted data + 24 bytes + number of bytes to the next 8 byte boundary.

Here are some sample column length calculations, which assume that a hint is not embedded:

Maximum length of non-encrypted data	6 bytes
24 bytes for encryption key	24 bytes
Number of bytes to the next 8 byte boundary	2 bytes

Encrypted data column length	32 bytes
Maximum length of non-encrypted data	32 bytes
24 bytes for encryption key	24 bytes
Number of bytes to the next 8 byte boundary	0 bytes

Encrypted data column length

56 bytes

Administration of encrypted data

Encrypted data can be decrypted only on servers that support the decryption of data that was encrypted using the Triple DES encryption algorithm. Hence, replication of columns with encrypted data should only be done to servers that support the decryption functions and the same encryption algorithms.

Syntax alternatives:

ENCRYPT is a synonym for ENCRYPT_TDES. Db2 supports this keyword to provide compatibility with other products in the Db2 family.

Examples

Example 1:

Encrypt the social security number that is inserted into the table. Set the ENCRYPTION PASSWORD value to 'Ben123' and use it as the password.

```
SET ENCRYPTION PASSWORD = 'Ben123';  
INSERT INTO EMP(SSN) VALUES ENCRYPT_TDES ('289-46-8832');
```

Example 2:

Encrypt the social security number that is inserted into the table. Explicitly specify 'Ben123' as the encryption password.

```
INSERT INTO EMP(SSN) VALUES ENCRYPT_TDES ('289-46-8832', 'Ben123');
```

Example 3

Encrypt the social security number that is inserted into the table. Specify 'Pacific' as the encryption password, and provide 'Ocean' as a hint to help the user remember the password of 'Pacific'.

```
INSERT INTO EMP(SSN) VALUES ENCRYPT_TDES ('289-46-8832', 'Pacific', 'Ocean');
```

The preceding statement returns a double precision floating-point number with an approximate value of 31.62.

EXP scalar function

The EXP function returns a value that is the base of the natural logarithm (e), raised to a power that is specified by the argument. The EXP and LN functions are inverse operations.

►► EXP(*numeric-expression*) ◀◀

The schema is SYSIBM.

The argument must be an expression that returns the value of any built-in numeric data type that is not DECFLOAT. If the argument is not a double precision floating-point number, it is converted to one for processing by the function.

The result of the function is a double precision floating-point number.

The result can be null; if the argument is null, the result is the null value.

Example: Assume that host variable E is DECIMAL(10,9) with a value of 3.453789832. The following statement returns a double precision floating-point number with an approximate value of 31.62.

```
SELECT EXP(:E)  
FROM SYSIBM.SYSDUMMY1;
```

EXTRACT scalar function

The EXTRACT function returns a portion of a date or timestamp, based on its arguments.

Extract date values:

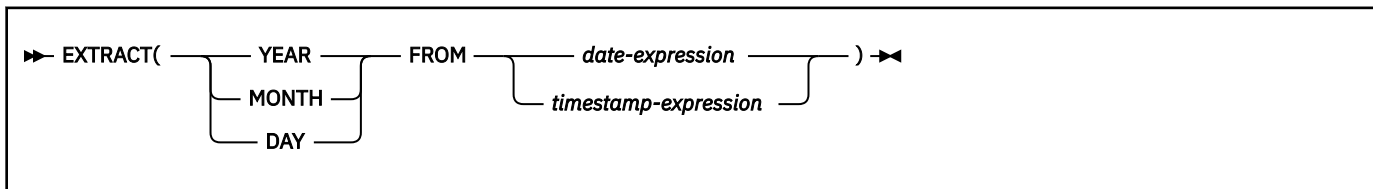

Extract time values:

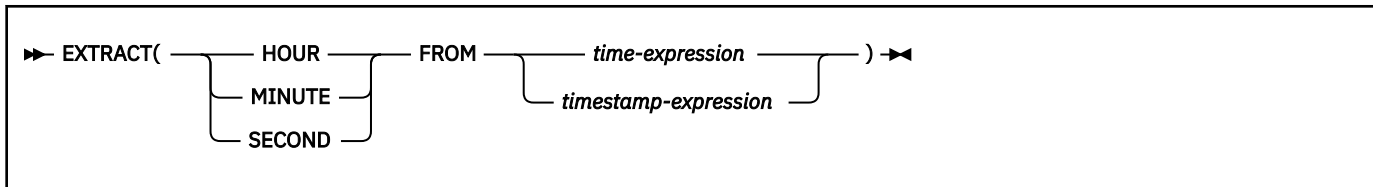

Extract time zone values:

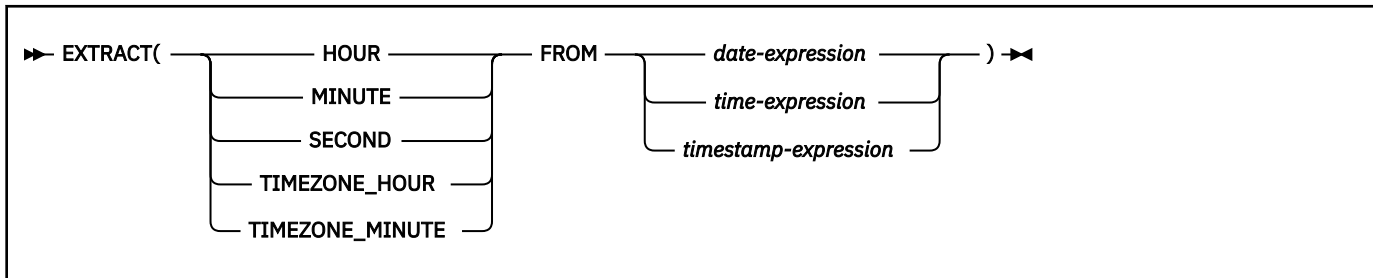

The schema is SYSIBM.

The result can be null; if the argument is null, the result is the null value.

Extract date values

YEAR

Specifies that the year portion of *date-expression* or *timestamp-expression* is returned. The result is identical to the YEAR scalar function. For more information, see [“YEAR scalar function”](#) on page 668.

MONTH

Specifies that the month portion of *date-expression* or *timestamp-expression* is returned. The result is identical to the MONTH scalar function. For more information, see [“MONTH scalar function”](#) on page 508.

DAY

Specifies that the day portion of *date-expression* or *timestamp-expression* is returned. The result is identical to the DAY scalar function. For more information, see [“DAY scalar function”](#) on page 426.

date-expression

An expression that returns the value of either a built-in date or built-in character string data type.

If *date-expression* is a character or graphic string, it must not be a CLOB or DBCLOB and its value must be a valid character-string or graphic-string representation of a date. For the valid formats of string representations of dates, see [“String representations of datetime values”](#) on page 120.

timestamp-expression

An expression that returns the value of either a built-in timestamp or built-in character string data type.

If *timestamp-expression* is a character or graphic string, it must not be a CLOB or DBCLOB and its value must be a valid character-string or graphic-string representation of a timestamp. For the valid formats of string representations of timestamps, see [“String representations of datetime values”](#) on page 120.

Extract time values

HOURL

Specifies that the hour portion of *time-expression* or *timestamp-expression* is returned. The result is identical to the HOUR scalar function. For more information, see [“HOURL scalar function”](#) on page 475.

MINUTE

Specifies that the minute portion of *time-expression* or *timestamp-expression* is returned. The result is identical to the MINUTE scalar function. For more information, see [“MINUTE scalar function”](#) on page 505.

SECOND

Specifies that the second portion of *time-expression* or *timestamp-expression* is returned. The result is identical to the SECOND scalar function where the precision and scale of the result depend on the type of *time-expression* or *timestamp-expression*. For more information, see [“SECOND scalar function”](#) on page 568.

time-expression

An expression that returns the value of either a built-in time or built-in character string data type.

If *time-expression* is a character or graphic string, it must not be a CLOB or DBCLOB and its value must be a valid string representation of a time. For the valid formats of string representations of times, see [“String representations of datetime values”](#) on page 120.

timestamp-expression

An expression that returns the value of either a built-in timestamp or built-in character string data type.

If *timestamp-expression* is a character or graphic string, it must not be a CLOB or DBCLOB and its value must be a valid string representation of a timestamp. For the valid formats of string representations of timestamps, see [“String representations of datetime values”](#) on page 120.

Extract time zone values

TIMEZONE_HOUR

Specifies that the hour component of the time zone of the timestamp value is returned. TIMEZONE_HOUR can only be specified if the second argument is a *timestamp-expression* and the *timestamp-expression* contains a time zone.

TIMEZONE_MINUTE

Specifies that the minute component of the time zone of the timestamp value is returned. TIMEZONE_MINUTE can only be specified if the second argument is a *timestamp-expression* and the *timestamp-expression* contains a time zone.

The values of TIMEZONE_HOUR and TIMEZONE_MINUTE shall either both be non-negative or both be non-positive.

If the *timestamp-expression* argument includes a time zone, the result is determined from the UTC representation of the datetime value.

The data type of the result of the function depends on the part of the datetime value that is specified:

- The result is INTEGER, if one of the following is specified:
 - YEAR
 - MONTH
 - DAY
 - HOUR
 - MINUTE

- TIMEZONE_HOUR
- TIMEZONE_MINUTE
- The result is DECIMAL(2+p, p) where p is the fractional second precision, if SECOND is specified with a TIMESTAMP(p) value.
- The result is DECIMAL(8,6), if SECOND is specified with a TIME value or a string representation of a TIME or timestamp. The fractional digits contains fractional seconds.

Example 1:

Assume that the column PRSTDATE has an internal value that is equivalent to 2010-12-25. The following statement returns the value 12:

```
SELECT EXTRACT(MONTH FROM PRSTDATE)
FROM PROJECT;
```

Example 2:

Assume that host variable PRSTSZ contains the value 2008-02-29-20.00.00.000000-08.30:

```
SELECT EXTRACT(HOUR FROM :PRSTSZ) FROM PROJECT;
```

The SELECT statement returns the value 4, which is the hour of the input datetime value expressed in UTC.

To return the same hour value as expressed in the input, cast the value to TIMESTAMP WITHOUT TIME ZONE before using the EXTRACT function:

```
SELECT EXTRACT(HOUR FROM CAST (:PRSTSZ AS TIMESTAMP )) FROM PROJECT;
```

The SELECT statement returns the value 20, which is the hour as it was originally expressed as a string in the host variable.

```
SELECT EXTRACT(TIMEZONE_HOUR FROM :PRSTSZ) FROM PROJECT;
```

This SELECT statement returns the value -8.

```
SELECT EXTRACT(TIMEZONE_MINUTE FROM :PRSTSZ) FROM PROJECT;
```

This SELECT statement returns the value -30.

FLOAT scalar function

The FLOAT function returns a floating-point representation of either a number or a string representation of a number.

►► FLOAT(*numeric-expression*) ◄◄

The schema is SYSIBM.

Notes

Syntax alternatives:

FLOAT is a synonym for DOUBLE_PRECISION or DOUBLE. For details, see [“DOUBLE_PRECISION or DOUBLE scalar function”](#) on page 451.

FLOOR scalar function

The FLOOR function returns the largest integer value that is less than or equal to the argument.

► FLOOR(*numeric-expression*) ◄

The schema is SYSIBM.

The argument must be an expression that returns a value of any built-in numeric data type.

The argument can also be a character string or graphic string data type. The string input is implicitly cast to a numeric value of DECFLOAT(34).

The result of the function has the same data type and length attribute as the argument. When the argument is DECIMAL, the scale of the result is 0 and not the scale of the input argument. For example, an argument with a date type of DECIMAL(5,5) results in DECIMAL(5,0).

The result can be null; if the argument is null, the result is the null value.

Example 1: Using sample table DSN8C10.EMP, find the highest monthly salary, rounding the result down to the next integer. The SALARY column has a decimal data type.

```
SELECT FLOOR(MAX(SALARY)/12)
FROM DSN8C10.EMP;
```

This example returns 04395 because the highest paid employee is Christine Haas who earns \$52750.00 per year. Her average monthly salary before applying the FLOOR function is 4395.83.

Example 2: This example demonstrates using FLOOR with both positive and negative numbers.

```
SELECT FLOOR( 3.5),
       FLOOR( 3.1),
       FLOOR(-3.1),
       FLOOR(-3.5)
FROM SYSIBM.SYSDUMMY1;
```

This example returns (leading zeros are shown to demonstrate the precision and scale of the result):

```
03. 03. -04. -04.
```

GENERATE_UNIQUE and GENERATE_UNIQUE_BINARY scalar functions

The GENERATE_UNIQUE and GENERATE_UNIQUE_BINARY functions return a value that is unique, compared to any other execution of the same function.

► GENERATE_UNIQUE() ◄
GENERATE_UNIQUE_BINARY()

The schema is SYSIBM.

The GENERATE_UNIQUE and GENERATE_UNIQUE_BINARY functions are defined as not deterministic. Although the functions have no arguments, the empty parentheses must be specified when the functions are invoked.

The result of either of the functions is a unique value that includes the internal form of the Universal Time, Coordinated (UTC) and, if in a sysplex environment, the sysplex member where the function was processed.

The data type of the result depends on which function was invoked. GENERATE_UNIQUE returns a bit data character string 13 bytes long (CHAR(13) FOR BIT DATA). GENERATE_UNIQUE_BINARY returns a BINARY(16) value.

The result cannot be null.

The results of these functions can be used to provide unique values in a table. The sequence is based on the time when the function was executed.

These functions differ from using the special register CURRENT_TIMESTAMP in that a unique value is generated for each row of a multiple row insert statement, an insert statement with a fullselect, or an insert operation in a MERGE statement.

The timestamp value that is part of the result of either of these functions can be determined using the TIMESTAMP function with the result of GENERATE_UNIQUE or GENERATE_UNIQUE_BINARY as an argument.

Example: Create a table that includes a column that is unique for each row. Populate this column using the GENERATE_UNIQUE function. Notice that the UNIQUE_ID column is defined as FOR BIT DATA to identify the column as a bit data character string.

```
CREATE TABLE EMP_UPDATE
  (UNIQUE_ID VARCHAR(13)FOR BIT DATA,
  EMPNO CHAR(6),
  TEXT VARCHAR(1000));
INSERT INTO EMP_UPDATE VALUES (GENERATE_UNIQUE(),'000020','Update entry 1...');
INSERT INTO EMP_UPDATE VALUES (GENERATE_UNIQUE(),'000050','Update entry 2...');
```

This table will have a unique identifier for each row if GENERATE_UNIQUE is always used to set the value the UNIQUE_ID column. You can create an insert trigger on the table to ensure that GENERATE_UNIQUE is used to set the value:

```
CREATE TRIGGER EMP_UPDATE_UNIQUE
NO CASCADE BEFORE INSERT ON EMP_UPDATE
REFERENCING NEW AS NEW_UPD
FOR EACH ROW MODE DB2SQL
SET NEW_UPD.UNIQUE_ID = GENERATE_UNIQUE();
```

With this trigger, the previous INSERT statements that were used to populate the table could be issued without specifying a value for the UNIQUE_ID column:

```
INSERT INTO EMP_UPDATE (EMPNO,TEXT) VALUES ('000020','Update entry 1...');
INSERT INTO EMP_UPDATE (EMPNO,TEXT) VALUES ('000050','Update entry 2...');
```

The timestamp (in UTC) for when a row was added to EMP_UPDATE can be returned using:

```
SELECT TIMESTAMP(UNIQUE_ID), EMPNO, TEXT FROM EMP_UPDATE;
```

Therefore, the table does not need a timestamp column to record when a row is inserted.

GETHINT scalar function

The GETHINT function returns a hint for the password if a hint was embedded in the encrypted data. A password hint is a phrase that helps you remember the password with which the data was encrypted. For example, 'Ocean' might be used as a hint to help remember the password 'Pacific'.

```
►► GETHINT( encrypted-data ) ◄◄
```

The schema is SYSIBM.

encrypted-data

An expression that returns a string that contains a complete, encrypted data string. *encrypted-data* must return a value that is a CHAR FOR BIT DATA, VARCHAR FOR BIT DATA, BINARY, or VARBINARY built-in data type. The string must have been encrypted using ENCRYPT_TDES function.

The result of the function is VARCHAR(32). The actual length of the result is the actual length of the hint that was provided when the data was encrypted.

The result can be null; if the argument is null, the result is the null value.

If no hint was specified when the ENCRYPT_TDES function was used to encrypt the data, the result is the null value.

The encoding scheme of the result is the same as the encoding scheme of *encrypted-data*. If *encrypted-data* is bit data, the CCSID of the result is the default character CCSID for that encoding scheme. Otherwise, the CCSID of the result is the same as the CCSID of *encrypted-data*.

For additional information about this function, see “[DECRYPT_BINARY, DECRYPT_BIT, DECRYPT_CHAR, and DECRYPT_DB scalar functions](#)” on page 444 and “[ENCRYPT_TDES or ENCRYPT scalar function](#)” on page 456.

Example: This example shows how to embed a hint for the password when encrypting data and how to later use the GETHINT function to retrieve the embedded hint. In this example, the hint 'Ocean' is used to help remember the encryption password 'Pacific'.

```
INSERT INTO EMP (SSN) VALUES ENCRYPT_TDES ('289-46-8832','Pacific','Ocean');
SELECT GETHINT (SSN) FROM EMP;
```

The value that is returned is 'Ocean'.

GETVARIABLE scalar function

The GETVARIABLE function returns a varying-length character-string representation of the current value of the session variable that is identified by the argument.

```
▶▶ GETVARIABLE( string-constant , [ default-value ] , [ CAST ( NULL AS VARCHAR(1) ) ] ) ▶▶
```

The schema is SYSIBM.

string-constant

Specifies a string constant that contains the name of the session variable whose value is to be returned. The string constant:

- Must have a length that does not exceed 142 bytes.
- Must contain the fully qualified name of the variable, with no embedded blanks. Delimited identifiers must not be specified.
- Must not contain lowercase letters or characters that cannot be specified in an ordinary identifier.

The schema qualifier for the variable must be:

- SYSIBM for built-in session variables. For a list of the built-in session variables, see “[Built-in session variables](#)” on page 336.
- SESSION for user-defined session variables. User-defined session variables are established via the connection or signon exit routines. For more information, see [Session variables in connection and sign-on routines \(Managing Security\)](#).

default-value

Specifies a string constant that contains the value to be returned if the specified variable does not exist or is not supported by Db2. *default-value* must be a string constant that does not exceed 255 bytes.

If *default-value* is not specified and the specified user-defined session variable does not exist or the built-in session variable is not supported by Db2, an error is returned.

CAST(NULL AS VARCHAR(1))

Specifies that a null value is to be returned if the specified variable does not exist or is not supported by Db2.

The data type of the result is VARCHAR(255). The result can be null.

The CCSID of the result is the CCSID for Unicode mixed data.

Notes

The GETVARIABLE function cannot obtain the values of built-in global variables or user-defined global variables.

Examples

Example 1

Use the GETVARIABLE function to set the value of host variable :hv1 to the name of the plan that is currently being executed. The name of the built-in session variable that contains the name of the plan is SYSIBM.PLAN_NAME.

```
SET :hv1 = GETVARIABLE('SYSIBM.PLAN_NAME');
```

If Db2 does not support the name of the session variable, an error is returned. For example, the following statement returns an error because Db2 does not support a built-in session variable that is named SYSIBM.XYZ.

```
SET :hv1 = GETVARIABLE('SYSIBM.XYZ');
```

Example 2

Use the GETVARIABLE function to set the value of host variable :hv2 to the value for the user that is defined in user-defined session variable TEST. If the session variable has not been set or cannot be found, have the function return the value 'TEST FAILED'.

```
SET :hv2 = GETVARIABLE('SESSION.TEST', 'TEST FAILED');
```

Example 3

Use the GETVARIABLE function to set the value of host variable :hv3 to a string representation of the SYSTEM EBCDIC CCSIDs. The name of the built-in session variable that contains the system EBCDIC CCSIDs is SYSIBM.SYSTEM_EBCDIC_CCSID.

```
SET :hv3 = GETVARIABLE('SYSIBM.SYSTEM_EBCDIC_CCSID');
```

Regardless of the setting of the field MIXED DATA on the installation panel (YES or NO), the function returns three comma-delimited values that correspond to the SBCS, MIXED, and GRAPHIC CCSIDs for the encoding scheme.

For example, if the statement were issued on a system with the field MIXED DATA on the installation panel equal to NO and the default system CCSID of 37, this string would be returned:

```
'37,65534,65534'
```

If the statement were issued on a system with the field MIXED DATA on the installation panel equal to YES and a default system CCSID of 930 (the mixed CCSID for the system), this string would be returned:

```
'290,930,300'
```

GRAPHIC scalar function

The GRAPHIC function returns a fixed-length graphic-string representation of the type of the first argument.

Syntax: Integer to Graphic

[FL 502](#)

► GRAPHIC(*integer-expression*) ◄

Syntax: Decimal to Graphic

[FL 502](#)

► GRAPHIC(*decimal-expression* , — *decimal-character*) ►

Syntax: Floating-point to Graphic

[FL 502](#)

► GRAPHIC(*floating-point-expression*) ►

Syntax: Decimal floating-point to Graphic

[FL 502](#)

► GRAPHIC(*decimal-floating-point-expression*) ►

Syntax: Character to Graphic:

► GRAPHIC(*character-expression* , — *integer* , — *CODEUNITS16* , — *CODEUNITS32*) ►

Syntax: Graphic to Graphic:

► GRAPHIC(*graphic-expression* , — *integer* , — *CODEUNITS16* , — *CODEUNITS32*) ►

The schema is SYSIBM.

The GRAPHIC function returns a graphic-string representation of:

- [FL 502](#) An integer number if the first argument is a SMALLINT, INTEGER, or BIGINT
- [FL 502](#) A decimal number if the first argument is a decimal number
- [FL 502](#) A double-precision floating-point number if the first argument is a DOUBLE or REAL
- [FL 502](#) A decimal floating-point number if the first argument is DECFLOAT
- A character string if the first argument is any type of character string
- A graphic string if the first argument is an EBCDIC or Unicode graphic string

The result can be null; if the first argument is null, the result is the null value.

The length attribute of the result is measured in double-byte characters because it is a graphic string.

Integer to Graphic

[FL 502](#)

integer-expression

An expression that returns a value that is an integer data type (either SMALLINT, INTEGER, or BIGINT).

The result is a fixed-length graphic string of the argument in the form of an SQL integer constant. The result is the smallest number of characters that can be used to represent the value of the argument, padded with blanks. The result consists of n characters that are the significant digits that represent the value of the argument with a preceding minus sign if the argument is negative. A positive value starts with a digit and always includes at least one trailing blank. Leading zeroes are not included. The result is left justified.

- If the argument is a small integer, the length of the result is 6. If the number of characters in the result is less than 6, the result is padded on the right with blanks.
- If the argument is a large integer, the length of the result is 11. If the number of characters in the result is less than 11, the result is padded on the right with blanks.
- If the argument is a big integer, the length of the result is 20. If the number of characters in the result is less than 20, the result is padded on the right with blanks.

The CCSID of the result is 1200 (UTF-16).

Decimal to Graphic

[FL 502](#)

decimal-expression

An expression that returns a value that is a built-in decimal data type. If a different precision and scale is wanted, the DECIMAL scalar function can be used to make the change. To specify a different precision and scale for the value of the expression, apply the DECIMAL function before applying the GRAPHIC function.

decimal-character

Specifies the single-byte character constant that is used to delimit the decimal digits in the result graphic string. The character must not be a digit, a plus sign (+), a minus sign (-), or a blank. The default is the period (.) or comma (,). For information on what factors govern the choice, see Decimal point representation.

The result is a fixed-length graphic string representation of the first argument. The result is the smallest number of characters that can be used to represent the value of the argument, except that trailing zeros are included. The result includes a decimal character and up to p digits, where p is the precision of the *decimal-expression* with a preceding minus sign if the argument is negative. A positive value starts with a digit or the decimal-character, and always includes at least one trailing blank. Leading zeros are not returned. If the scale of *decimal-expression* is zero, the decimal character is not returned. If the number of bytes in the result is less than the defined length of the result, the result is padded on the right with blanks.

The length of the result is $2+p$ where p is the precision of the *decimal-expression*.

The CCSID of the result is 1200 (UTF-16).

Floating-point to Graphic

[FL 502](#)

floating-point-expression

An expression that returns a value that is a floating-point data type (DOUBLE or REAL).

The result is a fixed-length graphic string representation of the argument in the form of an SQL floating-point constant. If the argument is negative, the first character of the result is a minus sign; otherwise, the first character is a digit. If the argument is zero, the result is OEO.

The length of the result is 24. The result includes the smallest number of characters that can represent the value of the argument such that the mantissa consists of a single digit, other than zero, followed by

a period and a sequence of digits. If the number of characters in the result is less than 24, the result is padded on the right with blanks.

The CCSID of the result is 1200 (UTF-16).

Decimal floating-point to Graphic

FL 502

decimal-floating-point-expression

An expression that returns a value that is a built-in decimal floating-point data type (DECFLOAT).

The result is a fixed-length graphic string representation of the argument in the form of an SQL decimal floating-point constant.

If the result value is Infinity, sNaN, or NaN, the strings 'INFINITY', 'SNAN', and 'NAN', respectively, are returned. The DECFLOAT special value sNaN does not result in an exception when converted to a string.

The length of the result is 42. If the number of characters in the result is less than 42, the result is padded on the right with blanks. Trailing zeros are significant. If the argument is negative, the first character of the result is a minus sign. Otherwise, the first character is a digit, or a letter if the DECFLOAT value is Infinity, sNaN, or NaN.

The CCSID of the result is 1200 (UTF-16).

Character to Graphic

character-expression

An expression that returns a value that is an EBCDIC-encoded or Unicode-encoded character string. It cannot be BIT data. The argument does not need to be mixed data, but any occurrences of X'0E' and X'0F' in the string must conform to the rules for EBCDIC mixed data. (See [“Character strings” on page 102](#) for these rules.)

The value of the expression must not be an empty string if *integer* is not specified or have the value X'0E0F' if the string is an EBCDIC string.

integer

The length of the resulting fixed-length graphic string in the units that are either implicitly or explicitly specified. The value must be an integer constant in the range 1–127. If the length of *character-expression* is less than the length specified, the result is padded with double-byte blanks to the length of the result.

If CODEUNITS16 or CODEUNITS32 is specified, see [“Determining the length attribute of the final result” on page 108](#) for information about how to calculate the length attribute of the result string.

If *integer* is not specified, the length of the result for an EBCDIC string is the minimum of 127 and the length attribute of *character-expression*, excluding shift characters. For a Unicode (UTF-8) string, the length is data dependent, but does not exceed 127.

CODEUNITS16 or CODEUNITS32

Specifies the unit that is used to express *integer*. If CODEUNITS16 or CODEUNITS32 is specified, the input is EBCDIC, and there is no system CCSID for EBCDIC GRAPHIC data, an error occurs.

CODEUNITS16

Specifies that *integer* is expressed in terms of 16-bit UTF-16 code units.

CODEUNITS32

Specifies that *integer* is expressed in terms of 32-bit UTF-32 code units.

For more information about CODEUNITS16 and CODEUNITS32, see [“String unit specifications” on page 106](#).

The CCSID of the result is the graphic CCSID that corresponds to the character CCSID of *character-expression*. If the input is EBCDIC and there is no system CCSID for EBCDIC GRAPHIC data, the CCSID of the result is X'FFFE'.

For EBCDIC data, each character of *character-expression* determines a character of the result. The argument might need to be converted to the native form of mixed data before the result is derived. Let *M* be the system CCSID for mixed data. The argument is not converted if any of the following conditions is true:

- The argument is mixed data and its CCSID is *M*.
- The argument is SBCS data and its CCSID is the same as the system CCSID for SBCS data. In this case, the operation proceeds as if the CCSID of the argument is *M*.

Otherwise, the argument is a new string *S* derived by converting the characters to the coded character set identified by *M*. If there is no system CCSID for EBCDIC mixed data, conversion is to the coded character set that the system CCSID for SBCS data identifies.

The result is derived from *S* using the following steps:

- Each shift character (X'0E' or X'0F') is removed.
- Each double-byte character remains as is.
- Each single-byte character is replaced by a double-byte character.

The replacement for an SBCS character is the equivalent DBCS character if an equivalent exists. Otherwise, the replacement is X'FEFE'. The existence of an equivalent character depends on *M*. If there is no system CCSID for mixed data, the DBCS equivalent of X'xxxx' for EBCDIC is X'42xx', except for X'40', whose DBCS equivalent is X'4040'.

For Unicode data:

Each character of *character-expression* determines a character of the result. The argument might need to be converted to the native form of mixed data before the result is derived. Let *M* be the system CCSID for mixed data. The argument is not converted if any of the following conditions is true:

- The argument is mixed data, and its CCSID is *M*.
- The argument is SBCS data, and its CCSID is the same as the system CCSID for SBCS data. In this case, the operation proceeds as if the CCSID of the argument is *M*.

Otherwise, the argument is a new string *S* derived by converting the characters to the coded character set identified by *M*.

The result is derived from *S* by using the following steps:

- Each non-supplementary character is replaced by a Unicode double-byte character (a UTF-16 code point). A non-supplementary character in UTF-8 is in the range 1–3 bytes.
- Each supplementary character is replaced by a pair of Unicode double-byte characters (a pair of UTF-16 code points).

The replacement for a single-byte character is the Unicode equivalent character if an equivalent exists. Otherwise, the replacement is X'FEFE'.

Graphic to Graphic

graphic-expression

An expression that returns a value that is a graphic string. The graphic string must not be an empty string if *integer* is not specified.

integer

The length of the resulting fixed-length graphic string in the units that are either implicitly or explicitly specified. The value must be an integer constant in the range 1–127. If the length of *graphic-expression* is less than the length specified, the result is padded with double-byte blanks to the length of the result.

If CODEUNITS16 or CODEUNITS32 is specified, see [“Determining the length attribute of the final result” on page 108](#) for information about how to calculate the length attribute of the result string.

If *integer* is not specified, the length of the result is the minimum of 127 and the length attribute of *graphic-expression*.

CODEUNITS16 or CODEUNITS32

Specifies the unit that is used to express *integer*. If CODEUNITS16 or CODEUNITS32 is specified, the input is EBCDIC, and there is no system CCSID for EBCDIC GRAPHIC data, an error occurs.

CODEUNITS16

Specifies that *integer* is expressed in terms of 16-bit UTF-16 code units.

CODEUNITS32

Specifies that *integer* is expressed in terms of 32-bit UTF-32 code units.

For more information about CODEUNITS16 and CODEUNITS32, see [“String unit specifications” on page 106](#).

If the length of the *graphic-expression* is greater than the specified length of the result, the result is truncated. Unless all the truncated characters are blanks, a warning is returned.

The CCSID of the result is the same as the CCSID of *graphic-expression*.

Notes

FL 502 Casting numeric data to Unicode:

The result of the GRAPHIC functions is Unicode (UTF-16) when the first argument is numeric data. The GRAPHIC function can only be invoked with numeric data for the first argument if the containing statement:

- references Unicode base tables or views only and the statement is qualified to be a single encoding scheme statement, or
- is considered a multiple encoding scheme statement and the application encoding scheme is Unicode.

Examples

Example 1:

Assume that MYCOL is a VARCHAR column in TABLEY. The following function returns the string in MYCOL as a fixed-length graphic string.

```
SELECT GRAPHIC(MYCOL)
FROM TABLEY;
```

Example 2:

Assume that an EMPLOYEE_U table exists that is similar to the EMPLOYEE sample table except that it is a Unicode table. The SALARY and COMM columns are defined as DECIMAL with a precision of 9 and a scale of 2. Return the total income for employee Haas as a fixed-length graphic string using the comma decimal character.

```
SELECT GRAPHIC(SALARY + COMM, ',')
FROM EMPLOYEE_U
WHERE LASTNAME = 'HAAS'
```

The result is the value G '56970,00 '.

GREATEST scalar function

The GREATEST function returns the maximum value in a set of values.

A diagram showing the syntax of the GREATEST function. It consists of the word 'GREATEST' followed by an opening parenthesis '(', then the word 'expression', a comma ',', another 'expression', and a closing parenthesis ')'. The word 'GREATEST' is preceded and followed by double arrows. A curved arrow points from the first 'expression' to the second 'expression', indicating that the function compares the two values to find the greater one.

►► GREATEST(*expression* , *expression*) ►►

The GREATEST function is identical to the MAX scalar function. For more information, see “MAX scalar function” on page 501.

HASH scalar function

The HASH function returns a varying-length value that is the result of applying the specified algorithm to the first argument. The function is intended for cryptographic purposes.

FL 506

►► HASH(*expression* , *algorithm*) ◄◄

The schema is SYSIBM.

expression

An expression that represents the string value that is to be hashed. The expression must return a built-in character string, graphic string, or binary string.

algorithm

An integer constant value of 0, 1, or 2 that indicates the hash algorithm to be used when the function name is HASH. If no algorithm is specified, the default value of 0 is used which indicates the MD5 algorithm.

The result is produced by applying the hash algorithm, *algorithm*, to *expression*.

The result of the function is VARBINARY, and the length attribute of the result depends on the hash algorithm used. The characteristics of the result are summarized in the following table:

Table 77. Characteristics of the result for each algorithm

Algorithm	Value for algorithm parameter	Result size	Number of different values that can be returned	HASH function result data type
MD5	0	128 bit	2^{128}	VARBINARY(16)
SHA1	1	160 bit	2^{160}	VARBINARY(20)
SHA256	2	256 bit	2^{256}	VARBINARY(32)

If the first argument can be null, the result can be null. If the first argument is null, the result is the null value.

Notes

Security considerations:

Security flaws have been identified in both the SHA1 and MD5 algorithms. You can find acceptable hash algorithms in applicable compliance documentation, such as National Institute of Standards and Technology (NIST) Special Publication 800-131A.

Syntax alternatives:

The HASH function is similar to the other hashing functions, where the hash algorithm is specified as part of the function name. For example:

```
HASH_MD5 ( expression )
```

Invoking the HASH function for hashing is recommended to increase the portability of applications.

Examples

Example 1:

Invoke the HASH function to use the MD5 algorithm to generate a hashed value.

```
SELECT HEX(HASH('ABCDEFGHIJKLMNOPQRSTUVWXYZ' , 0 ))
FROM SYSIBM.SYSDUMMYU;
```

The following value is returned:

```
X'E433BC7BE26A152E54E2EA0C92778160'
```

Example 2:

Invoke the HASH_SHA1 function to use the SHA1 algorithm to generate a hashed value.

```
SELECT HEX(HASH('ABCDEFGHIJKLMNOPQRSTUVWXYZ' , 1 ))
FROM SYSIBM.SYSDUMMYU;
```

The following value is returned:

```
X'8F34563A0FA4BA1A285C8035935D010629385474'
```

Example 3:

Invoke the HASH_SHA256 function to use the SHA256 algorithm to generate a hashed value.

```
SELECT HEX(HASH('ABCDEFGHIJKLMNOPQRSTUVWXYZ' , 2 ))
FROM SYSIBM.SYSDUMMYU;
```

The following value is returned:

```
X'403AC046B04F4A749E9810971083997B71F2B6FAF87CECCDE657E93FFCF700F0'
```

Related reference

[HASH_CRC32](#), [HASH_MD5](#), [HASH_SHA1](#), and [HASH_SHA256](#) scalar functions

The hashing functions return a fixed-length value that is the result of applying a hash algorithm to an input argument. The functions are intended for cryptographic purposes.

HASH_CRC32, HASH_MD5, HASH_SHA1, and HASH_SHA256 scalar functions

The hashing functions return a fixed-length value that is the result of applying a hash algorithm to an input argument. The functions are intended for cryptographic purposes.

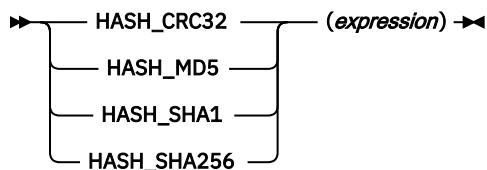

The schema is SYSIBM.

expression

An expression that represents the string value that is to be hashed. The expression must return a built-in character string, graphic string, or binary string.

The result is produced by applying the hash algorithm to *expression*. The hash algorithm is determined by the name of the function that is invoked.

The result of the function is BINARY, and the length attribute of the result depends on the hash algorithm specified. The characteristics of the result are summarized in the following table.

Table 78. Characteristics of the result for each algorithm

Function name	Algorithm	Result size	Number of different values that can be returned	Hash function result data type
HASH_CRC3 2	CRC32	32 bit	2^{32}	BINARY(4)
HASH_MD5	MD5	128 bit	2^{128}	BINARY(16)
HASH_SHA 1	SHA1	160 bit	2^{160}	BINARY(20)
HASH_SHA 256	SHA2-256	256 bit	2^{256}	BINARY(32)

If the first argument can be null, the result can be null. If the first argument is null, the result is the null value.

Note that security flaws have been identified in both the SHA1 and MD5 algorithms. You can find acceptable hash algorithms in applicable compliance documentation, such as National Institute of Standards and Technology (NIST) Special Publication 800-131A.

Notes

Syntax alternatives:

Hash functions HASH_MD5, HASH_SHA1, and HASH_SHA256 are similar to the following HASH function, where the hash algorithm is specified as an integer constant value of 0, 1, or 2:

```
HASH ( expression , integer-constant )
```

For these hash functions, invoking the HASH function for hashing is recommended to increase the portability of applications.

Examples

Example 1:

Invoke the HASH_CRC32 function to use the CRC32 algorithm to generate a hashed value.

```
SELECT HEX(HASH_CRC32('ABCDEFGHIJKLMNOPQRSTUVWXYZ'))
FROM SYSIBM.SYSDUMMYU;
```

The following value is returned:

```
X'B4B86309'
```

Example 2:

Invoke the HASH_MD5 function to use the MD5 algorithm to generate a hashed value.

```
SELECT HEX(HASH_MD5('ABCDEFGHIJKLMNOPQRSTUVWXYZ'))
FROM SYSIBM.SYSDUMMYU;
```

The following value is returned:

```
X'E433BC7BE26A152E54E2EA0C92778160'
```

Example 3:

Invoke the HASH_SHA1 function to use the SHA1 algorithm to generate a hashed value.

```
SELECT HEX(HASH_SHA1(' ABCDEFGHIJKLMNOPQRSTUVWXYZ '))
FROM SYSIBM.SYSDUMMYU;
```

The following value is returned:

```
X'8F34563A0FA4BA1A285C8035935D010629385474'
```

Example 4:

Invoke the HASH_SHA256 function to use the SHA256 algorithm to generate hashed value.

```
SELECT HEX(HASH_SHA256(' ABCDEFGHIJKLMNOPQRSTUVWXYZ '))
FROM SYSIBM.SYSDUMMYU;
```

The following value is returned:

```
X'403AC046B04F4A749E9810971083997B71F2B6FAF87CECCDE657E93FFCF700F0'
```

Related reference

HASH scalar function

The HASH function returns a varying-length value that is the result of applying the specified algorithm to the first argument. The function is intended for cryptographic purposes.

HEX scalar function

The HEX function returns a hexadecimal representation of a value.

►► HEX(*expression*) ►►

The schema is SYSIBM.

The argument must be an expression that returns a value of any built-in data type that is not XML. A character or binary string must not have a maximum length greater than 16352. A graphic string must not have a maximum length greater than 8176.

The result of the function is a character string.

The result can be null; if the argument is null, the result is the null value.

The result is a string of hexadecimal digits. The first two represent the first byte of the argument, the next two represent the second byte of the argument, and so forth. If the argument is a datetime value, the result is the hexadecimal representation of the internal form of the argument.

If the argument is a fixed-length string and the length of the result is less than 255, the result is a fixed-length string. Otherwise, the result is a varying-length string with a length attribute that depends on the following considerations:

If the argument is not a varying-length string, the length attribute of the result string is the same as the length of the result.

If the argument is a varying-length character or binary string, the length attribute of the result string is twice the length attribute of the argument.

If the argument is a varying-length graphic string, the length attribute of the result string is four times the length attribute of the argument.

If *expression* returns string data, the CCSID of the result is the SBCS CCSID that corresponds to the CCSID of *expression*. Otherwise, the CCSID of the result is determined from the context in which the function was invoked. For more information, see [Determining the encoding scheme and CCSID of a string \(Introduction to Db2 for z/OS\)](#).

If the argument is a graphic string, the length of the result is four times the maximum length of the argument. Otherwise, the length of the result is twice the (maximum) length of the argument.

Example: Return the hexadecimal representation of START_RBA in the SYSIBM.SYSCOPY catalog table.

```
SELECT HEX(START_RBA) FROM SYSIBM.SYSCOPY;
```

HOURL scalar function

The HOUR function returns the hour part of a value.

► HOUR(*expression*) ◄

The schema is SYSIBM.

The argument must be an expression that returns a value of one of the following built-in data types: a time, a timestamp, a character string, a graphic string, or a numeric data type.

- If *expression* is a character or graphic string, it must not be a CLOB or DBCLOB, and its value must be a valid string representation of a time or timestamp with an actual length of not greater than 255 bytes. For the valid formats of string representations of times and timestamps, see [“String representations of datetime values”](#) on page 120.
- If *expression* is a number, it must be a time or timestamp duration. For the valid formats of time and timestamp durations, see [“Datetime operands”](#) on page 169.

If *expression* is a timestamp with a time zone, or a valid string representation of a timestamp with a time zone, the result is determined from the UTC representation of the datetime value.

The result of the function is a large integer.

The result can be null; if the argument is null, the result is the null value.

The other rules depend on the data type of the argument:

If the argument is a time, timestamp, or string representation of either, the result is the hour part of the value, which is an integer in the range 1–24.

If the argument is a time duration or timestamp duration, the result is the hour part of the value, which is an integer between -99 and +99. A nonzero result has the same sign as the argument.

If the argument contains a time zone, the result is the hour part of the value expressed in UTC.

Example 1: Assume that a table named CLASSES contains a row for each scheduled class. Also assume that the class starting times are in a TIME column named STARTTM. Select those rows in CLASSES that represent classes that start after the noon hour.

```
SELECT *
FROM CLASSES
WHERE HOUR(STARTTM) > 12;
```

Example 2: The following invocations of the HOUR function returns the same result:

```
SELECT HOUR('2003-01-02-20.00.00'),
       HOUR('2003-01-02-12.00.00-08:00'),
       HOUR('2003-01-03-05.00.00+09:00')
FROM SYSIBM.SYSDUMMY1;
```

For each invocation of the HOUR function in this SELECT statement, the result is 20.

When the input argument contains a time zone, the result is determined from the UTC representation of the input value. The string representations of a timestamp with a time zone in the SELECT statement all have the same UTC representation: 2003-01-02-20.00.00.

IDENTITY_VAL_LOCAL scalar function

The IDENTITY_VAL_LOCAL function returns the most recently assigned value for an identity column.

► IDENTITY_VAL_LOCAL() ◄

The schema is SYSIBM.

The IDENTITY_VAL_LOCAL function is not deterministic.¹⁹ Although the function has no input parameters, the empty parentheses must be specified when the function is invoked.

The result is DECIMAL(31,0), regardless of the actual data type of the identity column to which the result value corresponds.

A *qualifying data change statement* refers to an insert operation (specified in either an INSERT statement or a MERGE statement).

The value that is returned is the value that was assigned to the identity column of the table identified in the most recent qualifying data change statement or LOAD utility operation for a table with an identity column. The insert operation has to be issued at the same level; that is, the value has to be available locally within the level at which it was assigned until replaced by the next assigned value. A new level is initiated when a trigger, function, or stored procedure is invoked. A trigger condition is at the same level as the associated triggered action.

The assigned value can be a value supplied by the user (if the identity column is defined as GENERATED BY DEFAULT) or an identity value that was generated by Db2.

The result can be null. The result is null in the following situations:

- When a qualifying data change statement has not been issued for a table containing an identity column at the current processing level
- When a COMMIT or ROLLBACK of a unit of work occurred since the most recent qualifying data change statement that assigned a value

The result of the function is not affected by a ROLLBACK TO SAVEPOINT statement.

Notes

Invoking the function within a qualifying data change statement:

Expressions in a qualifying data change statement are evaluated before values are assigned to the target columns of the qualifying data change statement. Thus, when you invoke IDENTITY_VAL_LOCAL in a qualifying data change statement, the value that is used is the most recently assigned value for an identity column from a previous qualifying data change statement. The function returns the null value if no such qualifying data change statement had been executed within the same level as the invocation of the IDENTITY_VAL_LOCAL function. Each qualifying data change statement that involves an IDENTITY column causes the identity value to be copied into connection-specific storage in Db2. Thus, the most recent identity value is used for a connection, regardless of what is happening with other concurrent user connections.

Invoking the function following a failed insert operation:

The function returns an unpredictable result when it is invoked after the unsuccessful execution of a qualifying data change statement for a table with an identity column. The value might be the value that would have been returned from the function had it been invoked before the failed qualifying data change statement or the value that would have been assigned had the qualifying data change statement succeeded. The actual value returned depends on the point of failure and is therefore unpredictable.

¹⁹ Being not deterministic affects what optimization (such as view processing and parallel processing) can be done when this function is used and in what contexts the function can be invoked. For example, the RAND function is another built-in scalar function that is not deterministic. Using functions that are not deterministic within a predicate can cause unpredictable results.

Invoking the function within the SELECT statement of a cursor:

Because the results of the IDENTITY_VAL_LOCAL function are not deterministic, the result of an invocation of the IDENTITY_VAL_LOCAL function from within the SELECT statement of a cursor can vary for each FETCH statement.

Invoking the function within the trigger condition of an insert trigger:

The result of invoking the IDENTITY_VAL_LOCAL function from within the condition of an insert trigger is the null value.

Invoking the function within a triggered action of an insert trigger:

Multiple before or after insert triggers can exist for a table. In such cases, each trigger is processed separately, and identity values generated by SQL statements issued within a triggered action are not available to other triggered actions using the IDENTITY_VAL_LOCAL function. This is the case even though the multiple triggered actions are conceptually defined at the same level.

Do not use the IDENTITY_VAL_LOCAL function in the triggered action of a before insert trigger. The result of invoking the IDENTITY_VAL_LOCAL function from within the triggered action of a before insert trigger is the null value.

The value for the identity column of the table for which the trigger is defined cannot be obtained by invoking the IDENTITY_VAL_LOCAL function within the triggered action of a before insert trigger. However, the value for the identity column can be obtained in the triggered action by referencing the trigger transition variable for the identity column.

The result of invoking the IDENTITY_VAL_LOCAL function in the triggered action of an after insert trigger is the value assigned to an identity column of the table identified in the most recent qualifying data change statement. That statement is the one invoked in the same triggered action that had a qualifying data change statement for a table containing an identity column. If a qualifying data change statement for a table containing an identity column was not executed within the same triggered action before invoking the IDENTITY_VAL_LOCAL function, then the function returns a null value.

Invoking the function following an insert operation with triggered actions:

The result of invoking the function after an insert that activates triggers is the value actually assigned to the identity column (that is, the value that would be returned on a subsequent SELECT statement). This value is not necessarily the value provided in the qualifying data change statement or a value generated by Db2. The assigned value could be a value that was specified in a SET transition variable statement within the triggered action of a before insert trigger for a trigger transition variable associated with the identity column.

Scope of IDENTITY_VAL_LOCAL:

The IDENTITY_VAL_LOCAL value persists until the next insert in the current session into a table that has an identity column defined on it, or the application session ends. The value is unaffected by COMMIT or ROLLBACK statements for local applications. The IDENTITY_VAL_LOCAL value cannot be directly set and is a result of inserting a row into a table. Client applications or middleware products that save the state of a session and then restore the state of a session for subsequent processing are not able to restore the IDENTITY_VAL_LOCAL value. In these situations, the availability of the IDENTITY_VAL_LOCAL value should only be relied on until the end of the transaction. Examples of where this type of situation can occur include applications that do the following actions:

- use XA protocols
- use connection pooling
- use the connection concentrator
- use sysplex workload balancing
- connect to a z/OS server that uses DDF inactive threads

When there is a need to preserve the value associated with IDENTITY_VAL_LOCAL across transaction boundaries for distributed applications, define the cursors as WITH HOLD, or specify the bind option KEEP DYNAMIC(YES) to prevent the server thread from being pooled.

Syntax alternatives:

Use a SELECT FROM data change statement to obtain the assigned value for an identity column. For more information, see [data-change-table-reference](#).

Examples

Example 1:

Set the variable *IVAR* to the value assigned to the identity column in the *EMPLOYEE* table. The value returned from the function in the *VALUES* statement should be 1.

```
CREATE TABLE EMPLOYEE
(EMPNO      INTEGER GENERATED ALWAYS AS IDENTITY,
 NAME       CHAR(30),
 SALARY     DECIMAL(5,2),
 DEPTNO    SMALLINT);
INSERT INTO EMPLOYEE
(NAME, SALARY, DEPTNO)
VALUES ('Rupert', 989.99, 50);
VALUES IDENTITY_VAL_LOCAL() INTO :IVAR;
```

Example 2:

Assume two tables, *T1* and *T2*, have an identity column named *C1*. Db2 generates values 1, 2, 3, . . . for the *C1* column in table *T1*, and values 10, 11, 12, . . . for the *C1* column in table *T2*.

```
CREATE TABLE T1 (C1 SMALLINT GENERATED ALWAYS AS IDENTITY,
                 C2 SMALLINT );
CREATE TABLE T2 (C1 DECIMAL(15,0) GENERATED BY DEFAULT AS IDENTITY
                 (START WITH 10),
                 C2 SMALLINT );
INSERT INTO T1 (C2) VALUES (5);
INSERT INTO T1 (C2) VALUES (5);
SELECT * FROM T1;
   C1          C2
-----
      1          5
      2          5
VALUES IDENTITY_VAL_LOCAL() INTO :IVAR;
```

At this point, the *IDENTITY_VAL_LOCAL* function would return a value of 2 in *IVAR*. The following *INSERT* statement inserts a single row into *T2* where column *C2* gets a value of 2 from the *IDENTITY_VAL_LOCAL* function

```
INSERT INTO T2 (C2) VALUES (IDENTITY_VAL_LOCAL());
SELECT * FROM T2
WHERE C1 = DECIMAL(IDENTITY_VAL_LOCAL(),15,0);
   C1          C2
-----
    10          2
```

Invoking the *IDENTITY_VAL_LOCAL* function after this insert would result in a value of 10, which is the value generated by Db2 for column *C1* of *T2*. Assume another single row is inserted into *T2*. For the following *INSERT* statement, Db2 assigns a value of 13 to identity column *C1* and gives *C2* a value of 10 from *IDENTITY_VAL_LOCAL*. Thus, *C2* is given the last identity value that was inserted into *T2*.

```
INSERT INTO T2 (C2, C1) VALUES (IDENTITY_VAL_LOCAL(), 13);
```

Example 3:

The *IDENTITY_VAL_LOCAL* function can also be invoked in an *INSERT* statement that both invokes the *IDENTITY_VAL_LOCAL* function and causes a new value for an identity column to be assigned. The next value to be returned is thus established when the *IDENTITY_VAL_LOCAL* function is invoked after the *INSERT* statement completes. For example, consider the following table definition:

```
CREATE TABLE T1 (C1 SMALLINT GENERATED BY DEFAULT AS IDENTITY,
                 C2 SMALLINT);
```

For the following INSERT statement, specify a value of 25 for the C2 column, and Db2 generates a value of 1 for C1, the identity column. This establishes 1 as the value that will be returned on the next invocation of the IDENTITY_VAL_LOCAL function.

```
INSERT INTO T1 (C2) VALUES (25);
```

In the following INSERT statement, the IDENTITY_VAL_LOCAL function is invoked to provide a value for the C2 column. A value of 1 (the identity value assigned to the C1 column of the first row) is assigned to the C2 column, and Db2 generates a value of 2 for C1, the identity column. This establishes 2 as the value that will be returned on the next invocation of the IDENTITY_VAL_LOCAL function.

```
INSERT INTO T1 (C2) VALUES (IDENTITY_VAL_LOCAL());
```

In the following INSERT statement, the IDENTITY_VAL_LOCAL function is again invoked to provide a value for the C2 column, and the user provides a value of 11 for C1, the identity column. A value of 2 (the identity value assigned to the C1 column of the second row) is assigned to the C2 column. The assignment of 11 to C1 establishes 11 as the value that will be returned on the next invocation of the IDENTITY_VAL_LOCAL function.

After

```
INSERT INTO T1 (C2, C1) VALUES (IDENTITY_VAL_LOCAL(), 11);
```

After the 3 INSERT statements have been processed, table T1 contains the following actions:

```
SELECT * FROM T1;
C1      C2
-----
       1      25
       2       1
      11       2
```

The contents of T1 illustrate that the expressions in the VALUES clause are evaluated before the assignments for the columns of the INSERT statement. Thus, an invocation of an IDENTITY_VAL_LOCAL function invoked from a VALUES clause of an INSERT statement uses the most recently assigned value for an identity column in a previous INSERT statement.

IFNULL scalar function

The IFNULL function returns the first nonnull expression.

```
►► IFNULL(expression,expression) ◄◄
```

The schema is SYSIBM.

IFNULL is identical to the COALESCE scalar function except that IFNULL is limited to two arguments instead of multiple arguments. For a description, see [“COALESCE scalar function”](#) on page 417.

Example: For all the rows in sample table DSN8C10.EMP, select the employee number and salary. If the salary is missing (is null), have the value 0 returned.

```
SELECT EMPNO, IFNULL(SALARY,0)
FROM DSN8C10.EMP;
```

INSERT scalar function

The INSERT function returns a string where, beginning at *start* in *source-string*, *length* characters have been deleted and *insert-string* has been inserted.

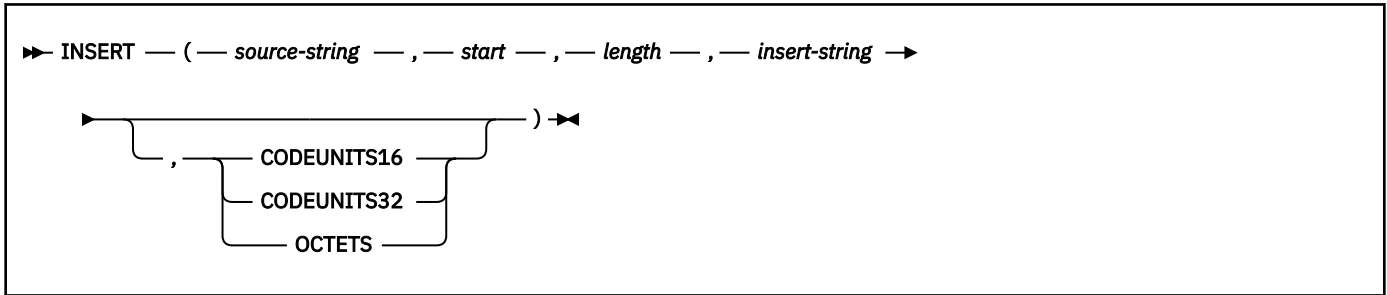

The schema is SYSIBM.

The INSERT function returns a string where *length* characters have been deleted from *source-string*, beginning at *start*, and where *insert-string* has been inserted into *source-string*, beginning at *start*.

source-string

An expression that specifies the source string. The expression must return a value that is a built-in character string, graphic string, or binary string data type that is not a LOB. The actual length of the string must be greater than or equal to 1 and less than or equal to 32704 bytes.

The argument can also be a numeric data type. The numeric argument is implicitly cast to a VARCHAR data type.

start

An expression that returns an integer. The integer specifies the starting point within the source string where the deletion of bytes and the insertion of another string is to begin. The value of the integer must be in the range of 1 to the length of *source-string* plus one. If OCTETS is specified and the result is graphic data, the value must be an odd value between 1 and twice the length of *source-string* plus one.

The argument can also be a character string or graphic string data type. The string argument is implicitly cast to a DECFLOAT(34) data type which is then assigned to an INTEGER.

length

An expression that specifies the length of the string to replace in *source-string* starting at *start*. *length* must be an expression that returns a value of the built-in INTEGER data type. *length* is expressed in the string unit specified, and the value must be in the range of 0 to the length of *source-string*. If OCTETS is specified and the result is graphic data, *length* must be even and be between 0 and twice the length of *source-string*. Not specifying *length* is equivalent to specifying a value of 1, except when OCTETS is specified and the result is graphic data, in which case, not specifying *length* is equivalent to specifying a value of 2.

The argument can also be a character string or graphic string data type. The string argument is implicitly cast to a DECFLOAT(34) data type which is then assigned to an INTEGER.

insert-string

An expression that specifies the string to be inserted into the source string, starting at the position identified by *start*. The expression must return a value that is a built-in character string, graphic string, or binary string data type that is not a LOB.

source-string and *insert-string* must have compatible data types.

The argument can also be a numeric data type. The numeric argument is implicitly cast to a VARCHAR data type.

CODEUNITS16, CODEUNITS32, or OCTETS

Specifies the units that are used to express *start* and *length*. If *source-string* is a character string that is defined as bit data, CODEUNITS16 and CODEUNITS32 cannot be specified. If *source-string*

is a graphic string, OCTETS cannot be specified. If *source-string* is a binary string, CODEUNITS16, CODEUNITS32, and OCTETS cannot be specified.

If a string unit is not explicitly specified, the data type of the result determines the unit that is used:

- If the result is a graphic string, a string unit is two bytes. For ASCII and EBCDIC data, this corresponds to a double byte character. For Unicode, this corresponds to a UTF-16 code point.
- Otherwise, a string unit is a byte.

CODEUNITS16

Specifies that *start* and *length* are expressed in terms of 16-bit UTF-16 code units.

CODEUNITS32

Specifies that *start* and *length* are expressed in terms of 32-bit UTF-32 code units.

OCTETS

Specifies that *start* and *length* are expressed in terms of bytes.

For more information about CODEUNITS16, CODEUNITS32, and OCTETS, see [“String unit specifications” on page 106](#).

If *source-string* and *insert-string* have different CCSID sets, *insert-string* (the string to be inserted) is converted to the CCSID of *source-string* (the source string).

The encoding scheme of the result is the same as *source-string*. The data type of the result of the function depends on the data type of *source-string* and *insert-string*:

- VARCHAR if *source-string* is a character string. The CCSID of the result depends on the arguments:
 - If either *source-string* or *insert-string* is character bit data, the result is bit data.
 - If *source-string* is SBCS Unicode data and *insert-string* is not SBCS Unicode data, the CCSID of the result is the mixed CCSID for Unicode data.
 - If both *source-string* and *insert-string* are SBCS Unicode data, the CCSID of the result is the CCSID for SBCS Unicode data.
 - Otherwise, the CCSID of the result is the mixed CCSID that corresponds to the CCSID of *source-string*. However, if the input is EBCDIC or ASCII and there is no corresponding system CCSID for mixed, the CCSID of the result is the CCSID of *source-string*.
- VARGRAPHIC if *source-string* is a graphic. The CCSID of the result is the same as the CCSID of *source-string*.
- VARBINARY if *source-string* and *insert-string* are both binary strings.

The length attribute of the result depends on the arguments:

- If *start* and *length* are constants, the length attribute of the result is:

$$L1 - \text{MIN}((L1 - V2 + 1), V3) + L4$$

where:

L1 is the length attribute of *source-string*

V2 is the value of *start*

V3 is the value of *length*

L4 is the length attribute of *insert-string*

- Otherwise, the length attribute of the result is the length attribute of *source-string* plus the length attribute of *insert-string*. In this case, the length attribute of *source-string* plus the length attribute of *insert-string* must not exceed 32704 for a VARCHAR result or 16352 for a VARGRAPHIC result.

If CODEUNITS16 or CODEUNITS32 is specified, the insert operation is performed on a Unicode version of the data. If needed, the data is converted to an intermediate form in order to evaluate the function. If an intermediate form is used, the actual length of the result depends on the original data (*source-string* and *insert-string*), and the representation of that data in Unicode. See [“Determining the length attribute of the final result” on page 108](#) for more information on how to calculate the length attribute of the result string.

If CODEUNITS16 or CODEUNITS32 are not specified, the actual length of the result is:

```
A1 - MIN((A1 - V2 + 1), V3) + A4
```

where:

- A1 is the actual length of *source-string*
- V2 is the value of *start*
- V3 is the value of *length*
- A4 is the actual length of *insert-string*

If the actual length of the result string exceeds the maximum for the return data type, an error occurs.

The result can be null; if any argument is null, the result is the null value.

Example 1: The following example shows how the string 'INSERTING' can be changed into other strings. The use of the CHAR function limits the length of the resulting string to 10 bytes.

```
SELECT CHAR(INSERT('INSERTING',4,2,'IS'),10),
       CHAR(INSERT('INSERTING',4,0,'IS'),10),
       CHAR(INSERT('INSERTING',4,2,''),10)
FROM SYSIBM.SYSDUMMY1;
```

This example returns 'INSISTING ', 'INSISERTIN', and 'INSTING '.

Example 2: The previous example demonstrated how to insert text into the middle of some text. This example shows how to insert text before some text by using 1 as the starting point (*start*).

```
SELECT CHAR(INSERT('INSERTING',1,0,'XX'),10),
       CHAR(INSERT('INSERTING',1,1,'XX'),10),
       CHAR(INSERT('INSERTING',1,2,'XX'),10),
       CHAR(INSERT('INSERTING',1,3,'XX'),10)
FROM SYSIBM.SYSDUMMY1;
```

This example returns 'XXINSERTIN', 'XXNSERTING', 'XXSERTING ', and 'XXERTING '.

Example 3: The following example shows how to insert text after some text. Add 'XX' at the end of string 'ABCABC'. Because the source string is 6 characters long, set the starting position to 7 (one plus the length of the source string).

```
SELECT CHAR(INSERT('ABCABC',7,0,'XX'),10)
FROM SYSIBM.SYSDUMMY1;
```

This example returns 'ABCABCXX '.

Example 4: The following example shows how the string 'Hegelstraße' can be changed to 'Hegelstrasse'.

```
SELECT VARCHAR(INSERT('Hegelstraße',10,1,'ss'),15)
FROM SYSIBM.SYSDUMMY1;
```

This example returns 'Hegelstrasse'.

INSTR scalar function

The INSTR function returns the position at which an argument starts within a specified string.

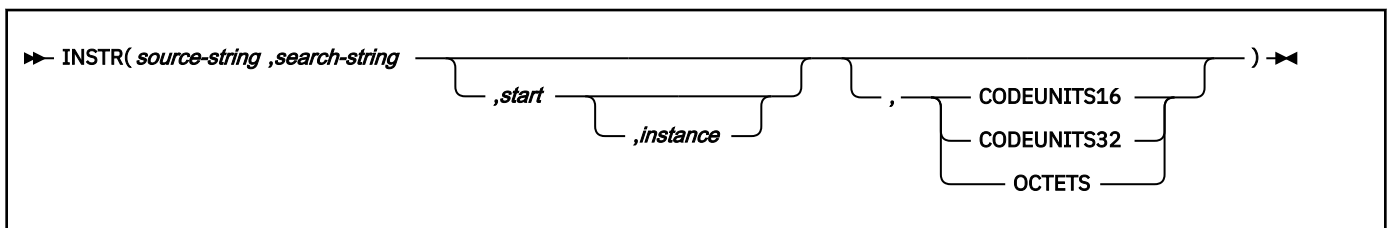

The schema is SYSIBM.

INSTR is identical to LOCATE_IN_STRING. For details, see [“LOCATE_IN_STRING scalar function”](#) on page 493.

INTEGER or INT scalar function

The INTEGER function returns an integer representation of either a number or a character string or graphic string representation of an integer.

Numeric to Integer:

```
INTEGER (numeric-expression)
INT
```

String to Integer:

```
INTEGER (string-expression)
INT
```

The schema is SYSIBM.

Numeric to Integer

numeric-expression

An expression that returns a value of any built-in numeric data type.

The result is the same number that would occur if the argument were assigned to a large integer column or variable. If the whole part of the argument is not within the range of large integers, an error occurs. The fractional part of the argument is truncated.

String to Integer

string-expression

An expression that returns a value of a character or graphic string (except a CLOB or DBCLOB) with a length attribute that is not greater than 255 bytes. The string must contain a valid string representation of a number.

The result is the same number that would result from `CAST(string-expression AS INTEGER)`. Leading and trailing blanks are eliminated and the resulting string must conform to the rules for forming an integer constant. If the whole part of the argument is not within the range of large integers, an error is returned.

The result of the function is a large integer.

The result can be null; if the argument is null, the result is the null value.

Notes

Syntax alternatives:

To increase the portability of applications, use the `CAST` specification. For more information, see [“CAST specification”](#) on page 267.

Examples

Example 1:

Using sample table DSN8C10.EMP, find the average salary of the employees in department A00, rounding the result to the nearest dollar.

```
SELECT INTEGER(AVG(SALARY)+.5)
FROM DSN8C10.EMP
WHERE WORKDEPT = 'A00';
```

Example 2:

Using sample table DSN8C10.EMP, select the EMPNO column, which is defined as CHAR(6), in integer form.

```
SELECT INTEGER(EMPNO)
FROM DSN8C10.EMP;
```

JULIAN_DAY

The JULIAN_DAY function returns an integer value that represents a number of days from January 1, 4713 B.C. (the start of the Julian date calendar) to the date that is specified in the argument.

►► JULIAN_DAY(*expression*) ◄◄

The schema is SYSIBM.

The argument must be an expression that returns one of the following data types: a date, a timestamp, or a valid string representation of a date or timestamp. An argument with a character string data type must not be a CLOB. An argument with a graphic string data type must not be a DBCLOB. A string argument must have an actual length that is not greater than 255 bytes. For the valid formats of string representations of dates and timestamps, see [“String representations of datetime values”](#) on page 120.

If *expression* is a timestamp with a time zone, or a valid string representation of a timestamp with a time zone, the result is determined from the UTC representation of the datetime value.

The result of the function is a large integer.

The result can be null; if the argument is null, the result is the null value.

Examples for JULIAN_DAY

Example 1

Using sample table DSN8C10.EMP, set the integer host variable JDAY to the Julian day of the day that Christine Haas (EMPNO = '000010') was employed (HIREDATE = '1965-01-01'). The result is that JDAY is set to 2438762.

```
SELECT JULIAN_DAY(HIREDATE)
INTO :JDAY
FROM DSN8C10.EMP
WHERE EMPNO = '000010';
```

Example 2

Set integer host variable JDAY to the Julian day for January 1, 1998. The result is that JDAY is set to 2450815.

```
SELECT JULIAN_DAY('1998-01-01')
INTO :JDAY
FROM SYSIBM.SYSDUMMY1;
```

Example 3

The following invocations of the JULIAN_DAY functions all return the same result, which is 2452642. When the input argument contains a time zone, the result is determined from the UTC representation

of the input value. The string representations of timestamps with a time zone in the example SELECT statement all have the same UTC representation: 2003-01-02-20.00.00.

```
SELECT JULIAN_DAY('2003-01-02-20.00.00'),
       JULIAN_DAY('2003-01-02-12.00.00-08:00'),
       JULIAN_DAY('2003-01-03-05.00.00+09:00')
FROM SYSIBM.SYSDUMMY1;
```

Related concepts

[Date, time, and timestamp data types \(Introduction to Db2 for z/OS\)](#)

[Datetime values](#)

Datetime values are neither strings nor numbers. Nevertheless, datetime values can be used in certain arithmetic and string operations and are compatible with certain strings.

Related reference

[DAYOFWEEK scalar function](#)

The DAYOFWEEK function returns an integer, in the range 1–7 that represents the day of the week, where 1 is Sunday and 7 is Saturday. The DAYOFWEEK function is similar to the DAYOFWEEK_ISO function.

LAST_DAY scalar function

The LAST_DAY scalar function returns a date that represents the last day of the month of the date argument.

►► LAST_DAY(*expression*) ◄◄

The schema is SYSIBM.

expression

An expression that specifies the starting date. The expression must return a value of one of the following data types:

- a date
- a timestamp
- a valid string representation of a date or timestamp

An argument with a character string data type must not be a CLOB. An argument with a graphic string data type must not be a DBCLOB. A string argument must have an actual length that is not greater than 255 bytes. A time zone in a string representation of a timestamp is ignored. For the valid formats of string representations of dates and timestamps, see [“String representations of datetime values” on page 120](#).

If *expression* is a TIMESTAMP WITH TIME ZONE value, *expression* is first cast to a TIMESTAMP WITHOUT TIME ZONE value with the same precision as *expression*.

The result of the function has the same data type as *expression*, unless *expression* is a string, in which case the result data type is DATE.

The result CCSID is the appropriate CCSID of the argument encoding scheme and the result subtype is the appropriate subtype of the CCSID.

The result can be null; if the argument is null, the result is the null value.

Any hours, minutes, seconds, or fractional seconds information that is included in *expression* is not changed by the function.

Example 1: Set the host variable *END_OF_MONTH* with the last day of the current month.

```
SET :END_OF_MONTH = LAST_DAY(CURRENT_DATE);
```

The host variable *END_OF_MONTH* is set with the value representing the end of the current month. If the current day is 2000-02-10, *END_OF_MONTH* is set to 2000-02-29.

Example 2: Set the host variable `END_OF_MONTH` with the last day of the month in EUR format for the given date.

```
SET :END_OF_MONTH = CHAR(LAST_DAY('1965-07-07'), EUR);
```

The host variable `END_OF_MONTH` is set with the value '31.07.1965'.

Example 3: Assume that host variable `PRSTSZ` contains '2008-02-29.20.00.000000 -08.30'. The `TIMESTAMP WITH TIME ZONE` value is implicitly cast to `TIMESTAMP WITHOUT TIME ZONE` before the `LAST_DAY` function is evaluated.

```
SELECT LAST_DAY(:PRSTSZ)
FROM PROJECT;
```

The `LAST_DAY` function returns the value '31' (month in UTC is March).

Example 4: Assume `PRSTSZ` is a host variable with the string value '2008-04-15.20.00.000000-08.30'. The string value, which is a string representation of a timestamp with a time zone, is implicitly cast to a `DATE` before the `LAST_DAY` function is evaluated. The `LAST_DAY` function returns the last day of the month as a `DATE` value.

```
SELECT LAST_DAY(:PRSTSZ)
FROM PROJECT;
```

The `LAST_DAY` function returns the value '2008-04-30', the last day of the month of April, as a `DATE` value.

Example 5: Assuming that the default date format is ISO, the following select statement returns '2000-04-30', which is the last day of April in 2000:

```
SELECT LAST_DAY('2000-04-24')
FROM SYSIBM.SYSDUMMY1;
```

LCASE scalar function

The `LCASE` function returns a string in which all the characters are converted to lowercase characters.

►► `LCASE(string-expression , — locale-name-string , — integer)` ►►

The schema is `SYSIBM`.

The `LCASE` function is identical to the `LOWER` function. For more information, see [“LOWER scalar function”](#) on page 495.

LEAST scalar function

The `LEAST` function returns the minimum value in a set of values.

►► `LEAST(expression , expression)` ►►

The `LEAST` function is identical to the `MIN` scalar function. For more information, see [“MIN scalar function”](#) on page 505.

LEFT scalar function

The LEFT function returns a string that consists of the specified number of leftmost bytes of the specified string units.

Character string:

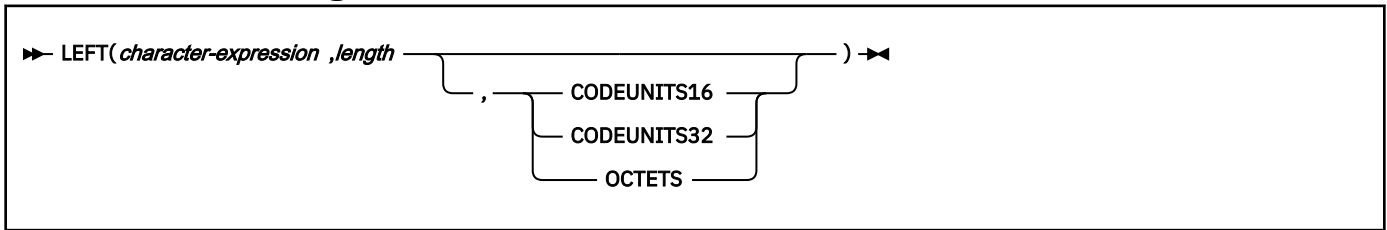

The schema is SYSIBM.

The LEFT function returns the leftmost string of *character-expression*, *graphic-expression*, or *binary-expression* consisting of length of the string units that are specified implicitly or explicitly.

character-expression

An expression that specifies the string from which the result is derived. The string must be a character string. A substring of *character-expression* is zero or more contiguous code points of *character-expression*.

The string can contain mixed data. Depending on the units that are specified to evaluate the function, the result is not necessarily a properly formed mixed data character string.

The argument can also be a numeric data type. The numeric argument is implicitly cast to a VARCHAR data type.

length

An expression that specifies the length of the result. The value must be an integer between 0 and *n*, where *n* is the length attribute of *character-expression*, expressed in the units that are either implicitly or explicitly specified.

The argument can also be a character string or graphic string data type. The string input is implicitly cast to a numeric value of DECFLOAT(34) which is then assigned to an INTEGER value.

If CODEUNITS16 or CODEUNITS32 is specified, see [“Determining the length attribute of the final result” on page 108](#) for information about how to calculate the length attribute of the result string.

CODEUNITS16, CODEUNITS32, or OCTETS

Specifies the unit that is used to express *integer*. If *string-expression* is a character string that is defined as bit data, CODEUNITS16 and CODEUNITS32 cannot be specified. If *string-expression* is a graphic string, OCTETS cannot be specified. If *string-expression* is a binary string, CODEUNITS16, CODEUNITS32, and OCTETS cannot be specified.

CODEUNITS16

Specifies that *integer* is expressed in terms of 16-bit UTF-16 code units.

CODEUNITS32

Specifies that *integer* is expressed in terms of 32-bit UTF-32 code units.

OCTETS

Specifies that *integer* is expressed in terms of bytes.

For more information about CODEUNITS16, CODEUNITS32, and OCTETS, see [“String unit specifications” on page 106](#).

The *character-expression*, *graphic-expression*, or *binary-expression* is effectively padded on the right with the necessary number of padding characters so that the specified substring of the expression always exists. The encoding scheme of the data determines the padding character:

- For ASCII SBCS data or ASCII mixed data, the padding character is X'20'.

- For ASCII DBCS data, the padding character depends on the CCSID; for example, for Japanese (CCSID 301) the padding character is X'8140', while for simplified Chinese it is X'A1A1'.
- For EBCDIC SBCS data or EBCDIC mixed data, the padding character is X'40'.
- For EBCDIC DBCS data, the padding character is X'4040'.
- For Unicode SBCS data or UTF-8 (Unicode mixed data), the padding character is X'20'.
- For UTF-16 (Unicode DBCS) data, the padding character is X'0020'.
- For binary data, the padding character is X'00'.

The result of the function is a varying-length string with a length attribute that is the same as the length attribute of the first expression and a data type that depends on the data type of the expression:

- VARCHAR if *character-expression* is CHAR or VARCHAR
- CLOB if *character-expression* is CLOB
- VARGRAPHIC if *graphic-expression* is GRAPHIC or VARGRAPHIC
- DBCLOB if *graphic-expression* is DBCLOB
- VARBINARY if *binary-expression* is BINARY or VARBINARY
- BLOB if *binary-expression* is BLOB

The actual length of the result is determined from *length*.

The result can be null; if any argument is null, the result is the null value.

The CCSID of the result is the same as that of the first expression.

Notes

Syntax alternatives:

[FL 506 STRLEFT](#) is a synonym for LEFT.

Examples

Example 1: Assume that host variable *ALPHA* has a value of 'ABCDEF'. The following statement returns 'ABC', which are the three leftmost characters in *ALPHA*:

```
SELECT LEFT(:ALPHA,3)
FROM SYSIBM.SYSDUMMY1;
```

Example 2: Assume that host variable *NAME*, which is defined as VARCHAR(50), has a value of 'KATIE AUSTIN' and the integer host variable *FIRSTNAME_LEN* has a value of 5. The following statement returns the value 'KATIE':

```
SELECT LEFT(:NAME, :FIRSTNAME_LEN)
FROM SYSIBM.SYSDUMMY1;
```

Example 3: The following statement returns a zero length string.

```
SELECT LEFT('ABCABC',0)
FROM SYSIBM.SYSDUMMY1;
```

Example 4: The *FIRSTNME* column in sample *EMP* table is defined as VARCHAR(12). Find the first name for an employee whose last name is 'BROWN' and return the first name in a 10-byte string.

```
SELECT LEFT(FIRSTNME,10)
FROM DSN8C10.EMP
WHERE LASTNAME='BROWN';
```

This function returns a VARCHAR(10) string that has the value of 'DAVID' followed by 5 blank characters.

Example 5: FIRSTNAME is a VARCHAR(12) column in table T1. One of its values is the 6-character string 'Jürgen'. When FIRSTNAME has this value:

Function ...	Returns ...
LEFT(FIRSTNAME,2,CODEUNITS32)	'Jü' -- x'4AC3BC'
LEFT(FIRSTNAME,2,CODEUNITS16)	'Jü' -- x'4AC3BC'
LEFT(FIRSTNAME,2,OCTETS)	'J ' -- x'4A20' A truncated string

Example 6: In the following example, the last invocation of the LEFT function returns a partial surrogate character:

Function ...	Returns ...
LEFT('Jürgen',2,CODEUNITS32)	'Jü' -- x'4AC3BC'
LEFT('Jürgen',2,CODEUNITS16)	'Jü' -- x'4AC3BC'
LEFT('Jürgen',2,OCTETS)	'J ' -- x'4A20' A truncated string
HEX(LEFT('Jürgen',2))	x'4AC3' -- The letter 'J' and a partial character

LENGTH scalar function

The LENGTH function returns the length of a value.

►► LENGTH(*expression*) ◄◄

The schema is SYSIBM.

The argument must be an expression that returns a value of any built-in data type that is not XML.

The result of the function is a large integer.

The result can be null; if the argument is null, the result is the null value.

The result is the length of the argument. The length does not include the null indicator byte of column arguments that allow null values. The length of strings includes blanks. The length of a varying-length string is the actual length, not the maximum length.

The length of a graphic string is the number of double-byte characters. Unicode UTF-16 data is treated as graphic data; a UTF-16 supplementary character takes two DBCS characters to represent and as such is counted as two DBCS characters.

The length of all other values is the number of bytes used to represent the value:

- 2 for small integer
- 4 for large integer
- 8 for big integer
- The integer part of $(p/2)+1$ for decimal numbers with precision p
- 16 for DECFLOAT(34)
- 8 for DECFLOAT(16)
- 4 for single precision floating-point
- 8 for double precision floating-point
- The length of the string for strings
- 4 for DATE
- 3 for TIME
- 10 for TIMESTAMP
- 12 for TIMESTAMP WITH TIME ZONE
- $7+((p+1)/2)$ for TIMESTAMP(p)
- $9+((p+1)/2)$ for TIMESTAMP(p) WITH TIME ZONE
- The length of the row ID

Example 1: Assume that FIRSTNME is a VARCHAR(12) column that contains 'ETHEL' for employee 280. The following query returns the value 5:

```
SELECT LENGTH(FIRSTNME)
FROM DSN8C10.EMP
WHERE EMPNO = '000280';
```

Example 2: Assume that HIREDATE is a column of data type DATE. Then, regardless of value the following statement returns the value 4:

```
LENGTH(HIREDATE)
```

And the following function returns the value 10:

```
LENGTH(CHAR(HIREDATE, EUR))
```

LN scalar function

The LN function returns the natural logarithm of the argument. The LN and EXP functions are inverse operations.

►► LN(*numeric-expression*) ◄◄

The schema is SYSIBM.

The argument must be an expression that returns the value of any built-in numeric data type that is not DECFLOAT. If the argument is not a double precision floating-point number, it is converted to one for processing by the function.

The result of the function is a double precision floating-point number.

The result can be null; if the argument is null, the result is the null value.

Notes

Syntax alternatives:

LOG is a synonym for LN. However, it is supported only for compatibility with previous Db2 releases. LN should be used instead of LOG because some database managers and applications implement LOG as the natural logarithm of a number instead of the common logarithm of a number.

Examples

Example: Assume that host variable NATLOG is DECIMAL(4,2) with a value of 31.62. The following statement returns a double precision floating-point number with an approximate value of 3.45:

```
SELECT LN(:NATLOG)
FROM SYSIBM.SYSDUMMY1;
```

LOCATE scalar function

The LOCATE function returns the position at which the first occurrence of an argument starts within another argument.

►► LOCATE(*search-string* , *source-string* , *start*) ◄◄

```
LOCATE( search-string , source-string , start )
```

The schema is SYSIBM.

The LOCATE function returns the starting position of *search-string* within *source-string*. If *search-string* is not found and neither argument is null, the result is zero. If *search-string* is found, the result is a number from 1 to the actual length of *source-string*. If *search-string* has a length of zero, the result returned by the function is 1. If the optional *start* is specified, it indicates the character position in *source-string* at which the search is to begin. An optional string unit can be specified to indicate in what units the start and result of the function are expressed.

search-string

An expression that specifies the string that is to be searched for. *search-string* must return a value that is a built-in character string data type, graphic string data type, or binary string data type with an actual length that is no greater than 4000 bytes.

The argument can also be a numeric data type. The numeric argument is implicitly cast to a VARCHAR data type.

source-string

An expression that specifies the source string in which the search is to take place. *source-string* must return a value that is a built-in character string data type, graphic string data type, or binary string data type.

The argument can also be a numeric data type. The numeric argument is implicitly cast to a VARCHAR data type.

start

An expression that specifies the position within *search-string* where the search is to start.

start is expressed in the specified string unit and must return an integer value that is greater than or equal to zero.

The argument can also be a character string or graphic string data type. The string input is implicitly cast to a numeric value of DECFLOAT(34) which is then assigned to an INTEGER value.

CODEUNITS16, CODEUNITS32, or OCTETS

Specifies the string unit that is used to express *start* and the result. If *source-string* is a character string that is defined as bit data, CODEUNITS16 and CODEUNITS32 cannot be specified. If *source-string* is a graphic string, OCTETS cannot be specified. If *source-string* is a binary string, CODEUNITS16, CODEUNITS32, and OCTETS cannot be specified.

CODEUNITS16

Specifies that *start* and the result are expressed in terms of 16-bit UTF-16 code units.

CODEUNITS32

Specifies that *start* and the result are expressed in terms of 32-bit UTF-32 code units.

OCTETS

Specifies that *start* and the result are expressed in terms of bytes.

If a string unit is not explicitly specified, the data type of the result determines the string unit that is used. If the result is graphic data, *start* and the returned position are expressed in two-byte units; otherwise, they are expressed in bytes.

For more information about CODEUNITS16, CODEUNITS32, and OCTETS, see [“String unit specifications” on page 106](#).

The first and second arguments must have compatible string types. For more information on compatibility, see [“Conversion rules for comparisons” on page 159](#).

The result of the function is a large integer.

The result can be null; if any argument is null, the result is the null value.

Notes

Similar functions:

If *start* is specified, the LOCATE function is similar to the following POSITION function, where *string-units* is CODEUNITS16, CODEUNITS32, or OCTETS:

```
POSITION(search-string,  
        SUBSTRING(source-string, start, string-units)) + start - 1
```

If *start* is not specified, the search begins at the first position of *source-string* and the LOCATE function is similar to the following POSITION function, where *string-units* is CODEUNITS16, CODEUNITS32, or OCTETS:

```
POSITION(search-string, source-string, string-units)
```

For more information, see [“POSITION scalar function” on page 529](#).

Examples

Example 1:

Find the location of the first occurrence of the character 'N' in the string 'DINING'.

```
SELECT LOCATE('N', 'DINING')  
FROM SYSIBM.SYSDUMMY1;
```

The result is the value 3.

Example 2:

For all the rows in the table named IN_TRAY, select the RECEIVED column, the SUBJECT column, and the starting position of the string 'GOOD' within the NOTE_TEXT column.

```
SELECT RECEIVED, SUBJECT, LOCATE('GOOD', NOTE_TEXT)  
FROM IN_TRAY  
WHERE LOCATE('GOOD', NOTE_TEXT) <> 0;
```

Example 3:

Locate the character 'ß' in the string 'Jürgen lives on Hegelstraße', and set the host variable LOCATION with the position, as measured in CODEUNITS32 units, within the string.

```
SET :LOCATION = LOCATE('ß', 'Jürgen lives on Hegelstraße', 1, CODEUNITS32);
```

The value of host variable LOCATION is set to 26.

Example 4:

Locate the character 'ß' in the string 'Jürgen lives on Hegelstraße', and set the host variable LOCATION with the position, as measured in CODEUNITS16 units, within the string.

```
SET :LOCATION = LOCATE('ß', 'Jürgen lives on Hegelstraße', 1, CODEUNITS16);
```

The value of host variable LOCATION is set to 26.

Example 5:

Locate the character 'ß' in the string 'Jürgen lives on Hegelstraße', and set the host variable LOCATION with the position, as measured in OCTETS, within the string.

```
SET :LOCATION = LOCATE('ß', 'Jürgen lives on Hegelstraße', 1, OCTETS);
```

The value of host variable LOCATION is set to 27.

LOCATE_IN_STRING scalar function

The LOCATE_IN_STRING function returns the position at which an argument starts within a specified string.

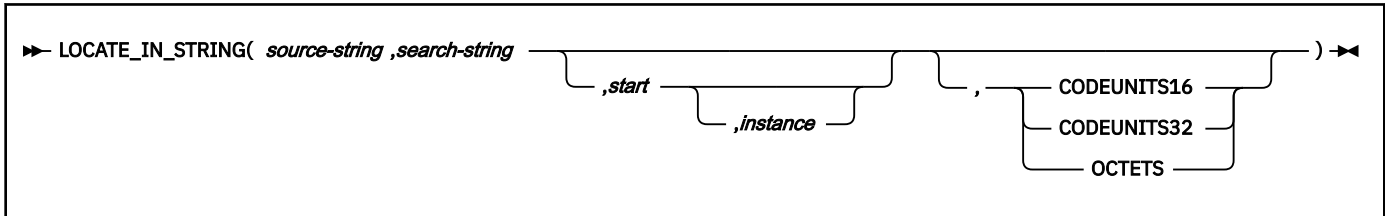

The schema is SYSIBM.

The LOCATE_IN_STRING function returns the starting position of a string (called the *search-string*) within another string (called the *source-string*). If the *search-string* is not found and neither argument is null, the result is zero. If the *search-string* is found, the result is a number from 1 to the actual length of the *source-string*.

If the optional *start* is specified, an optional instance number can also be specified. The instance argument is used to determine the specific occurrence of *search-string* within *source-string*. Each unique instance can include any of the characters in a previous instance, but not all characters in a previous instance. An optional string unit can be specified to indicate in what units the *start* and result of the function are expressed.

If the *search-string* has a length of zero, the result returned by the function is 1. If the *source-string* has a length of zero, the result returned by the function is 0. If neither condition exists, and if the value of *search-string* is equal to an identical length of a substring of contiguous positions within the value of *source-string*, the result returned by the function is the starting position of that substring within the *source-string* value; otherwise, the result returned by the function is 0.

source-string

An expression that specifies the source string in which the search is to take place. *source-string* must return a value that is a built-in character string data type, graphic string data type, or binary string data type.

The argument can also be a numeric data type. The numeric argument is implicitly cast to a VARCHAR data type.

search-string

An expression that specifies the string that is the object of the search. *search-string* must return a value that is a built-in character string data type, graphic string data type, or binary string data type with an actual length that is no greater than 4000 bytes.

The argument can also be a numeric data type. The numeric argument is implicitly cast to a VARCHAR data type.

start

An expression that specifies the position within *source-string* at which the search is to start. The expression must return a value that is a built-in INTEGER or SMALLINT data type.

The argument can also be a character string or graphic string data type. The string input is implicitly cast to a numeric value of DECFLOAT(34) which is then assigned to an INTEGER value.

If the value of the integer is greater than zero, the search begins at *start* and continues for each position to the end of the string. If the value of the integer is less than zero, the search begins at the $\text{LENGTH}(\textit{source-string}) + \textit{start} + 1$ and continues for each position to the beginning of the string.

If *start* is not specified, the default is 1. If the value of the integer is zero, an error is returned.

instance

An expression that specifies which instance of *search-string* to search for within *source-string*. The expression must return a value that is a built-in INTEGER or SMALLINT data type. If *instance* is not specified, the default is 1. The value of the integer must be greater than or equal to one.

CODEUNITS16, CODEUNITS32, or OCTETS

Specifies the string unit that is used to express *start* and the result. If *source-string* is a character string that is defined as bit data, CODEUNITS16 and CODEUNITS32 cannot be specified. If *source-string* is a graphic string, OCTETS cannot be specified. If *source-string* is a binary string, CODEUNITS16, CODEUNITS32, and OCTETS cannot be specified.

CODEUNITS16

Specifies that *start* and the result are expressed in terms of 16-bit UTF-16 code units.

CODEUNITS32

Specifies that *start* and the result are expressed in terms of 32-bit UTF-32 code units.

OCTETS

Specifies that *start* and the result are expressed in terms of bytes.

If a string unit is not explicitly specified, the data type of the result determines the string unit that is used. If the result is graphic data, *start* and the returned position are expressed in two-byte units; otherwise, they are expressed in bytes.

For more information about CODEUNITS16, CODEUNITS32, and OCTETS, see [“String unit specifications”](#) on page 106.

The first and second arguments must have compatible string types. For more information on compatibility, see [“Conversion rules for comparisons”](#) on page 159.

At each search position, a match is found when the substring at that position and LENGTH(*search-string*) - 1 values to the right of the search position in *source-string*, is equal to *search-string*.

The result of the function is a large integer. The result is the starting position of the instance of *search-string* within *source-string*. The value is relative to the beginning of the string (regardless of the specification of *start*).

The result can be null; if any argument is null, the result is the null value.

Notes

Syntax alternatives:

INSTR is a synonym for LOCATE_IN_STRING.

Examples

Example 1:

Find the position of an occurrence of the character 'N' in the string 'WINNING' by searching from the start of the string as measured in bytes, within the string.

```
SELECT LOCATE_IN_STRING('WINNING', 'N', 1, 3, OCTETS),
       LOCATE_IN_STRING('WINNING', 'N', 3, 2, OCTETS),
       LOCATE_IN_STRING('WINNING', 'N', 3, 3, OCTETS),
       LOCATE_IN_STRING('WINNING', 'N', -1, 3, OCTETS),
       LOCATE_IN_STRING('WINNING', 'N', -3, 2, OCTETS),
       LOCATE_IN_STRING('WINNING', 'N', -3, 3, OCTETS)
FROM SYSIBM.SYSDUMMY1;
```

Returns the values:

```
6   4   6   3   3   0
```

LOG10 scalar function

The LOG10 function returns the common logarithm (base 10) of a number.

►► LOG10(*numeric-expression*) ◄◄

The schema is SYSIBM.

The argument is an expression that returns the value of any built-in numeric data type that is not DECFLOAT. If the argument is not a double precision floating-point number, it is converted to one for processing by the function.

The result of the function is a double precision floating-point number.

The result can be null; if the argument is null, the result is the null value.

Example: Assume that host variable HLOG is an INTEGER with a value of 100. The following statement returns a double precision floating-point number with an approximate value of 2:

```
SELECT LOG10(:HLOG)
FROM SYSIBM.SYSDUMMY1;
```

LOWER scalar function

The LOWER function returns a string in which all the characters are converted to lowercase characters.

► LOWER(*string-expression* , — *locale-name-string* , — *integer*) ►

The schema is SYSIBM.

string-expression

An expression that specifies the string to be converted. *string-expression* must return a value that is a built-in character or graphic string. A character string argument must not be a CLOB, and a graphic string argument must not be a DBCLOB. If *string-expression* is an EBCDIC graphic string, a blank string must not be specified for *locale-name-string*. If *string-expression* is bit data, *locale-name-string* must not be specified.

The argument can also be a numeric data type. The numeric argument is implicitly cast to a VARCHAR data type.

locale-name-string

A string constant or a string host variable other than a CLOB or DBCLOB that specifies a valid locale name. If *locale-name-string* is not in EBCDIC, it is converted to EBCDIC. The length of *locale-name-string* must be in the range 1–255 bytes of the EBCDIC representation. The value of *locale-name-string* is not case sensitive and must be a valid locale. For information on locales and their naming conventions, see [Building and using Dynamic Link Libraries \(DLLs\) \(XL C/C++ Programming Guide\)](#). Some examples of locales include:

```
Fr_BE
Fr_FR@EURO
En_US
Ja_JP
```

The conversion process is determined by the value that is specified for the locale name, as follows:

blank

SBCS uppercase characters A-Z are converted to SBCS lowercase characters a-z, and characters with diacritical marks are not converted. If the string contains MIXED or DBCS characters, full-width Latin uppercase characters A-Z are converted to full-width lowercase characters a-z. For optimal performance, specify a blank string unless your data must be processed by using the rules that are defined by a specific locale.

UNI

The conversion uses both the NORMAL and SPECIAL casing capabilities as described in [Select the conversions \(z/OS: Unicode Services User's Guide and Reference\)](#). You must not specify UNI when *string-expression* is EBCDIC data.

UNI_60

The conversion uses Unicode Standard 6.0.0 and the NORMAL casing capability, as described in [Select the conversions \(z/OS: Unicode Services User's Guide and Reference\)](#). You must not specify UNI_60 when *string-expression* is EBCDIC data.

UNI_90

The conversion uses Unicode Standard 9.0.0 and the NORMAL casing capability, as described in [Select the conversions \(z/OS: Unicode Services User's Guide and Reference\)](#). You must not specify UNI_90 when *string-expression* is EBCDIC data.

UNI_SIMPLE

Case conversions use the NORMAL casing capabilities as described in [Select the conversions \(z/OS: Unicode Services User's Guide and Reference\)](#). UNI_SIMPLE cannot be used with EBCDIC data.

locale name

The locale defines the rules for conversion to lowercase characters.

The value of the host variable must not be null. If the host variable has an associated indicator variable, the value of the indicator variable must not indicate a null value. The locale name must be:

- left justified within the host variable
- padded on the right with blanks if its length is less than that of the host variable and the host variable is in fixed length character or graphic data type

If *locale-name-string* is not specified, the locale is determined by special register CURRENT LOCALE LC_CTYPE. For information about the special register, see [“CURRENT LOCALE LC_CTYPE special register” on page 196](#). However, if an index references the LOWER function, the local is determined as follows (in order) to determine if the index can be used:

- At prepare time: using the value in the CURRENT LOCALE LC_CTYPE special register
- At bind time: using the value in the LOCALE LC_CTYPE field on installation panel DSNTIPF

If the index is chosen in the access path, the locale in the CURRENT LOCALE LC_CTYPE special register must remain the same at run time, and prepare or bind time. To avoid this dependency, do not omit *locale-name-string*.

If the LOWER function is referenced in an expression-based index, *locale-name-string* must be specified. See the examples section for an example of how the index can be used in a query.

integer

An integer value that specifies the length attribute of the result. If specified, *integer* must be an integer constant in the range 1–32704 bytes in the representation of the encoding scheme of *string-expression*.

If *integer* is not specified, the length attribute of the result is the same as the length of *string-expression*.

For Unicode data, usage of the LOWER function can result in expansion if certain characters are processed. For example, LOWER ('İ') –UX'00CC'– will result in UX'006903070300' (if the LT_LT locale is in effect at the time). You should ensure that the result length is large enough to contain the result of the expression.

The result can be null; if the argument is null, the result is the null value.

Notes

Syntax alternatives:

LCASE is a synonym for LOWER. LOWER should be used for conformance to the SQL standard.

Examples

Example 1:

Return the characters in the value of host variable NAME in lowercase. NAME has a data type of VARCHAR(30) and a value of 'Christine Smith'. Assume that the locale in effect is blank.

```
SELECT LCASE(:NAME)
FROM SYSIBM.SYSDUMMY1;
```

The result is the value 'christine smith'.

Example 2:

Return the lowercase of 'İ'. Assume that the locale in effect is LT_LT.

```
SELECT LOWER('İ')
FROM SYSIBM.SYSDUMMYU;
```

This would result in an error because of the expansion that occurs when certain Unicode characters are processed. To avoid the error, you would need to use the following statement instead:

```
SELECT LOWER(VARCHAR('İ', 3))
FROM SYSIBM.SYSDUMMYU;
```

The result of the preceding statement is the value UX'006903070300'.

Example 3:

Create an index EMPLOYEE_NAME_LOWER for table EMPLOYEE based on built-in function LOWER with locale name 'LT_LT'.

```
CREATE INDEX EMPLOYEE_NAME_LOWER
ON EMPLOYEE (LOWER(LASTNAME, 'LT_LT', 60),
             LOWER(FIRSTNAME, 'LT_LT', 60),
             ID);
```

Example 4:

Create an index LNAME for table T1 based on the LOWER function with the default local value, ''. Then specify the same expression in a query.

```
CREATE INDEX LNAME
ON T1 (LOWER(LASTNAME, ''));

SELECT LOWER(LASTNAME, '')
FROM T1
WHERE LOWER(LASTNAME, '') = 'smith';
```

Example 5:

Create an index LNAME that is based on the LOWER function with a locale name 'FR_CA' for the table T1. Then specify the same expression in a query except *locale-name-string* is omitted.

```
CREATE INDEX LNAME
ON T1 (LOWER(LASTNAME, 'FR_CA'));
```

If the query is a dynamic statement and the CURRENT LOCALE LC_CTYPE special register contains 'FR_CA':

```
SELECT LASTNAME
FROM T1
WHERE LOWER(LASTNAME)='smith';
```

At prepare time, locale 'FR_CA' in CURRENT LOCALE LC_CTYPE is used for LOWER(LASTNAME) in the predicate to determine whether index LNAME can be used for index access. If index LNAME is used in access path selection, at run time, the locale in CURRENT LOCALE LC_CTYPE must remain the same.

If the query is a static statement and locale 'FR_CA' has been set on the LOCALE LC_CTYPE field of installation panel DSNTIPF:

```
SELECT LASTNAME
FROM TI
WHERE LOWER(LASTNAME)='smith';
```

At bind time, local 'FR_CA' in the LOCALE LC_CTYPE file of installation panel DSNTIPF is used for LOWER(LASTNAME) in the predicate to determine whether index LNAME is used for index access. If index LNAME is chosen in access path selection, the locale in the CURRENT LOCALE LC_CTYPE special register must contain 'FR_CA'.

Related concepts

[z/OS Unicode Services User's Guide and Reference](#)

Related reference

[z/OS XL C/C++ Programming Guide](#)

LPAD scalar function

The LPAD function returns a string that is composed of *string-expression* that is padded on the left, with *pad* or blanks. The LPAD function treats leading or trailing blanks in *string-expression* as significant.

```
LPAD(string-expression, integer, pad)
```

Padding occurs only if the actual length of *string-expression* is less than *integer*, and if *pad* is not an empty string.

The schema is SYSIBM.

string-expression

An expression that specifies the source string. The expression must return a value that is a built-in string data type that is not a LOB.

integer

An integer constant that specifies the length of the result. The value must be zero or a positive integer that is less than or equal to *n*, where *n* is 32704 if *string-expression* is a character or binary string, or where *n* is 16352 if *string-expression* is a graphic string.

pad

An expression that specifies the string with which to pad. The expression must return a value that is a built-in string data type that is not a LOB. If *pad* is not specified, the pad character is determined as follows:

- SBCS blank character if *string-expression* is a character string.
- DBCS blank character if *string-expression* is a graphic string.
- Hexadecimal zero (X'00'), if *string-expression* is a binary string.

The result of the function is a varying length string that has the same CCSID of *string-expression*. *string-expression* and *pad* must have compatible data types. If the string expressions have different CCSID sets, then *pad* is converted to the CCSID set of *string-expression*. If either *string-expression* or *pad* is FOR BIT DATA, no character conversion occurs.

The length attribute of the result depends on *integer*. If *integer* is greater than 0, the length attribute of the result is *integer*. If *integer* is 0, the length attribute of the result is 1.

The actual length of the result is determined from *integer*. If *integer* is 0, the actual length is 0, and the result is the empty result string. If *integer* is less than the actual length of *string-expression*, the actual length is *integer* and the result is truncated.

The result can be null; if any argument is null, the result is the null value.

Example 1: Assume that NAME is a VARCHAR(15) column that contains the values 'Chris', 'Meg', and 'Jeff'. The following query will pad a value on the left with periods.

```
SELECT LPAD(NAME,15,'.' ) AS NAME
FROM T1;
```

The results are similar to the following output:

```
NAME
-----
.....Chris
.....Meg
.....Jeff
```

Example 2: Similar to Example 1, the following query will only pad each value to a length of 5:

```
SELECT LPAD(NAME,5,'.' ) AS NAME
FROM T1;
```

The results are similar to the following output:

```
NAME
-----
Chris
..Meg
.Jeff
```

Example 3: Assume that NAME is a CHAR(15) column containing the values 'Chris', 'Meg', and 'Jeff'. Note that the LPAD function does not pad because NAME is a fixed length character field and is blank padded already. However, since the length of the result is 5, the columns are truncated:

```
SELECT LPAD(NAME,5,'.' ) AS NAME
FROM T1;
```

The results are similar to the following output:

```
NAME
-----
Chris
Meg
Jeff
```

Example 4: Assume that NAME is a VARCHAR(15) column containing the values 'Chris', 'Meg', and 'Jeff'. Note that in some cases, a partial instance of the pad specification is returned.

```
SELECT LPAD(NAME,15,'123') AS NAME
FROM T1
```

The results are similar to the following output:

```
NAME
-----
1231231231Chris
123123123123Meg
12312312312Jeff
```

LTRIM scalar function

The LTRIM function removes bytes from the beginning of a string expression based on the content of a trim expression.

```
►► LTRIM — ( — string-expression — , — trim-expression ) —►
```

The schema is SYSIBM.

The LTRIM function removes all of the characters that are contained in *trim-expression* from the beginning of *string-expression*. The search is done by comparing the binary representation of each character (which consists of one or more bytes) in *trim-expression* to the bytes at the beginning of *string-expression*. If the *string-expression* is defined as FOR BIT DATA, the search is done by comparing each byte in *trim-expression* to the byte at the beginning of *string-expression*.

string-expression

An expression that specifies the source string. The argument must be an expression that returns a value that is a built-in string data type that is not a LOB, or a numeric data type. If the value is not a string data type, it is implicitly cast to VARCHAR before the function is evaluated. If *string-expression* is not FOR BIT DATA, *trim-expression* must not be FOR BIT DATA.

trim-expression

An expression that specifies the characters to remove from the beginning of *string-expression*. The expression must return a value that is a built-in string data type that is not a LOB, or a numeric data type. If the value is not a string data type, it is implicitly cast to VARCHAR before the function is evaluated.

The default for *trim-expression* depends on the data type of *string-expression*:

- A DBCS blank if *string-expression* is a DBCS graphic string. For ASCII, the CCSID determines the hex value that represents a DBCS blank. For example, for Japanese (CCSID 301), X'8140' represents a DBCS blank, while for Simplified Chinese, X'A1A1' represents a DBCS blank. For EBCDIC, X'4040' represents a DBCS blank.
- A UTF-16 or UCS-2 blank (X'0020') if *string-expression* is a Unicode graphic string.
- A value of X'00' if *string-expression* is a binary string.
- Otherwise, a single byte blank. For EBCDIC, X'40' represents a blank. If not EBCDIC, X'20' represents a blank.

string-expression and *trim-expression* must have compatible data types. If *string-expression* and *trim-expression* have different CCSID sets, *trim-expression* is converted to the CCSID of *string-expression*.

The result of the function depends on the data type of *string-expression*:

- VARCHAR if *string-expression* is a character string. If *string-expression* is defined as FOR BIT DATA the result is FOR BIT DATA.
- VARGRAPHIC if *string-expression* is a graphic string.
- VARBINARY if *string-expression* is a binary string.

The length attribute of the result is the same as the length attribute of *string-expression*.

The actual length of the result for a character or binary string is the length of *string-expression* minus the number of bytes that are removed. The actual length of the result for a graphic string is the length (in the number of double byte characters) of *string-expression* minus the number of double byte characters removed. If all of the characters bytes are removed, the result is an empty string (the length is zero).

The result can be null; if the argument is null, the result is the null value.

The CCSID of the result is the same as that of *string-expression*.

Notes

Valid content for EBCDIC mixed string input:

If *string-expression* is an EBCDIC mixed string, the string must contain valid EBCDIC mixed data.

Examples

Example: Use the LTRIM function to remove individual numbers in the second argument from the beginning of the first argument:

```
SELECT LTRIM ('123DEFG123', '321'),
       LTRIM ('12DEFG123', '321'),
       LTRIM ('123123222XYZ22', '123'),
       LTRIM ('12321', '213'),
       LTRIM ('YX123 ', '321')
FROM SYSIBM.SYSDUMMY1
```

The result is 'DEFG123', 'DEFG123', 'XYZ22', '' (an empty string - all characters removed), and 'YX123' (no characters removed).

The LTRIM function does not remove instances of '1', '2', and '3' on the right side of the string, following characters that are not '1', '2', or '3'.

Example: Use the LTRIM function to remove individual special characters in the second argument from the beginning of the first argument:

```
SELECT LTRIM ('[[ -78]]', '- []')
FROM SYSIBM.SYSDUMMY1
```

The result is '78]]'.

Example: Use the LTRIM function to remove dollar signs and periods in the second argument from the beginning of the first argument:

```
SELECT LTRIM ('...$V..$AR', '$. ')
FROM SYSIBM.SYSDUMMY1
```

The result is 'V..\$AR'.

Example: Use the LTRIM function to trim full multi-byte X'D090' characters:

Assume that these strings are encoded in UTF-8.

```
SELECT LTRIM (X'D090D091D092', X'D090')
FROM SYSIBM.SYSDUMMY1
```

The result is X'D091D092'.

Note that the function does not remove individual bytes x'D0' and x'90'.

MAX scalar function

The MAX scalar function returns the maximum value in a set of values.



The schema is SYSIBM.

The arguments must be compatible. For more information on compatibility, refer to the compatibility matrix in [Table 30 on page 144](#). All but the first argument can be parameter markers. There must be two or more arguments.

Each argument must be an expression that returns a value of any built-in data type other than a CLOB, DBCLOB, BLOB, ROWID, or XML.

Character string arguments and binary string arguments cannot have a length attribute greater than 32704, and graphic string arguments cannot have a length attribute greater than 16352.

The arguments are evaluated in the order in which they are specified. The result of the function is the maximum argument value.

The result can be null; if any argument is null, the result is the null value.

The selected argument is converted, if necessary, to the attributes of the result. The attributes of the result are determined using the “Rules for result data types” on page 166. If the MAX function has more than two arguments, the rules are applied to the first two arguments to determine a candidate result type. The rules are then applied to that candidate result type and the third argument to determine another candidate result type. This process continues until all arguments are analyzed and the final result type and CCSID is determined.

Notes

Syntax alternatives:

GREATEST is a synonym for MAX.

Examples

Example 1: Assume the host variable *M1* is a DECIMAL(2,1) host variable with a value of 5.5, host variable *M2* is a DECIMAL(3,1) host variable with a value of 4.5, and host variable *M3* is a DECIMAL(3,2) host variable with a value of 6.25. The following function returns the value 6.25.

```
MAX( :M1 , :M2 , :M3 )
```

Example 2: Assume the host variable *M1* is a CHAR(2) host variable with a value of 'AA', host variable *M2* is a CHAR(3) host variable with a value of 'AA ', and host variable *M3* is a CHAR(4) host variable with a value of 'AA A'. The following function returns the value 'AA A'.

```
MAX( :M1 , :M2 , :M3 )
```

MAX_CARDINALITY scalar function

The MAX_CARDINALITY function returns a value of type BIGINT that represents the maximum number of elements that an array can contain. This value is the cardinality that was specified in the CREATE TYPE statement for an ordinary array type.

```
► MAX_CARDINALITY( array-expression ) ◄
```

The schema is SYSIBM.

array-expression

An SQL variable, SQL parameter, or global variable of an array type, or a CAST specification that specifies an SQL variable, SQL parameter, global variable, or parameter marker as the source value.

The result of the MAX_CARDINALITY function is as follows:

- For an ordinary array, the result is the maximum number of elements that an array can contain.
- For an associative array, the result is the null value.

The data type of the result is BIGINT.

If the argument is an associative array, the result can be null and the result is the null value. Otherwise, the result cannot be null.

Examples

Example 1: Suppose that array type PHONENUMBERS and array variable RECENT_CALLS are defined as follows:

```
CREATE TYPE PHONENUMBERS AS DECIMAL(10,0) ARRAY[50];
CREATE VARIABLE RECENT_CALLS PHONENUMBERS;
```

The following statement sets LIST_SIZE to the maximum cardinality with which RECENT_CALLS was defined.

```
SET LIST_SIZE = MAX_CARDINALITY(RECENT_CALLS);
```

After the statement executes, LIST_SIZE contains 50.

MICROSECOND scalar function

The MICROSECOND function returns the microsecond part of a value.

► MICROSECOND(*expression*) ◄

The schema is SYSIBM.

The argument must be an expression that returns a value of one of the following built-in data types: a timestamp, a character string, a graphic string, or a numeric data type.

- If *expression* is a character or graphic string, it must not be a CLOB or DBCLOB, and its value must be a valid string representation of a timestamp with an actual length of not greater than 255 bytes. For the valid formats of string representations of times and timestamps, see [“String representations of datetime values” on page 120](#).
- If *expression* is a number, it must be a timestamp duration. For the valid formats of timestamp durations, see [“Datetime operands” on page 169](#).

If *expression* is a timestamp with a time zone, or a valid string representation of a timestamp with a time zone, the result is determined from the UTC representation of the datetime value.

The result of the function is a large integer.

The result can be null; if the argument is null, the result is the null value.

The other rules depend on the data type of the argument:

If the argument is a timestamp or string representation of a timestamp, the result is the microsecond part of the value, which is an integer in the range 0–999999. If the precision of the timestamp exceeds 6, the value is truncated.

If the argument is a duration, the result is the microsecond part of the value, which is an integer between -999999 and 999999. A nonzero result has the same sign as the argument.

Example 1: Assume that table TABLEX contains a TIMESTAMP column named TSTMPCOL and a SMALLINT column named INTCOL. Select the microseconds part of the TSTMPCOL column of the rows where the INTCOL value is 1234:

```
SELECT MICROSECOND(TSTMPCOL) FROM TABLEX
WHERE INTCOL = 1234;
```

Example 2: The following invocations of the MICROSECOND function returns the same result:

```
SELECT MICROSECOND('2003-01-02-20.00.00.123456'),
       MICROSECOND('2003-01-02-12.00.00.123456-08:00'),
       MICROSECOND('2003-01-03-05.00.00.123456+09:00')
FROM SYSIBM.SYSDUMMY1;
```

For each invocation of the MICROSECOND function in this SELECT statement, the result is 123456.

When the input argument contains a time zone, the result is determined from the UTC representation of the input value. The string representations of a timestamp with a time zone in the SELECT statement all have the same UTC representation: 2003-01-02-20.00.00.123456.

MIDNIGHT_SECONDS scalar function

The MIDNIGHT_SECONDS function returns an integer, in the range 0–86400, that represents the number of seconds between midnight and the time that is specified in the argument.

```
►► MIDNIGHT_SECONDS( expression ) ◄◄
```

The schema is SYSIBM.

The argument must be an expression that returns a value of one of the following built-in data types: a time, a timestamp, a character string, or a graphic string. If *expression* is a character or graphic string, it must not be a CLOB or DBCLOB, and its value must be a valid string representation of a time or timestamp with an actual length of not greater than 255 bytes. For the valid formats of string representations of times and timestamps, see [“String representations of datetime values” on page 120](#).

If *expression* is a timestamp with a time zone, or a valid string representation of a timestamp with a time zone, the result is determined from the UTC representation of the datetime value.

The result of the function is a large integer.

The result can be null; if the argument is null, the result is the null value.

Example 1: Find the number of seconds between midnight and 00:01:00, and midnight and 13:10:10. Assume that host variable *XTIME1* has a value of '00:01:00', and that *XTIME2* has a value of '13:10:10'.

```
SELECT MIDNIGHT_SECONDS(:XTIME1), MIDNIGHT_SECONDS(:XTIME2)
FROM SYSIBM.SYSDUMMY1;
```

This example returns 60 and 47410. Because there are 60 seconds in a minute and 3600 seconds in an hour, 00:01:00 is 60 seconds after midnight ((60 * 1) + 0), and 13:10:10 is 47410 seconds ((3600 * 13) + (60 * 10) + 10).

Example 2: Find the number of seconds between midnight and 24:00:00 of a specified day, and between midnight and 00:00:00 of the following day.

```
SELECT MIDNIGHT_SECONDS('2019-05-20-24:00:00'),
MIDNIGHT_SECONDS('2019-05-21-00:00:00')
FROM SYSIBM.SYSDUMMY1;
```

This example returns 86400 and 0. Although the two MIDNIGHT_SECONDS arguments represent the same point in time, different values are returned.

Example 3: The following invocations of the MIDNIGHT_SECONDS function return the same result:

```
SELECT MIDNIGHT_SECONDS('2003-01-02-20.10.05.123456'),
MIDNIGHT_SECONDS('2003-01-02-12.10.05.123456-08:00'),
MIDNIGHT_SECONDS('2003-01-03-05.10.05.123456+09:00')
FROM SYSIBM.SYSDUMMY1;
```

For each invocation of the MIDNIGHT_SECONDS function in this SELECT statement, the result is 72605.

When the input argument contains a time zone, the result is determined from the UTC representation of the input value. The string representations of a timestamp with a time zone in the SELECT statement all have the same UTC representation: 2003-01-02-20.10.05.123456.

MIN scalar function

The MIN scalar function returns the minimum value in a set of values.

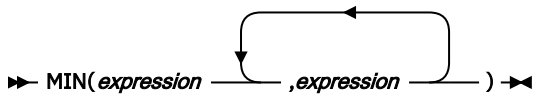

```
MIN(expression, expression)
```

The schema is SYSIBM.

The arguments must be compatible. For more information on compatibility, refer to the compatibility matrix in [Table 30 on page 144](#). All but the first argument can be parameter markers. There must be two or more arguments.

Each argument must be an expression that returns a value of any built-in data type other than a CLOB, DBCLOB, BLOB, ROWID, or XML.

Character string arguments and binary string arguments cannot have a length attribute greater than 32704, and graphic string arguments cannot have a length attribute greater than 16352.

The arguments are evaluated in the order in which they are specified. The result of the function is the minimum argument value.

The result can be null; if any argument is null, the result is the null value.

The selected argument is converted, if necessary, to the attributes of the result. The attributes of the result are determined using the “Rules for result data types” on [page 166](#). If the MIN function has more than two arguments, the rules are applied to the first two arguments to determine a candidate result type. The rules are then applied to that candidate result type and the third argument to determine another candidate result type. This process continues until all arguments are analyzed and the final result type and CCSID is determined.

Notes

Syntax alternatives:

LEAST is a synonym for MIN.

Examples

Example 1: Assume the host variable *M1* is a DECIMAL(2,1) host variable with a value of 5.5, host variable *M2* is a DECIMAL(3,1) host variable with a value of 4.5, and host variable *M3* is a DECIMAL(3,2) host variable with a value of 6.25. The following function returns the value 4.5.

```
MIN(:M1, :M2, :M3)
```

Example 2: Assume the host variable *M1* is a CHAR(2) host variable with a value of 'AA', host variable *M2* is a CHAR(3) host variable with a value of 'AAA', and host variable *M3* is a CHAR(4) host variable with a value of 'AAAA'. The following function returns the value 'AA'.

```
MIN(:M1, :M2, :M3)
```

MINUTE scalar function

The MINUTE function returns the minute part of a value.



```
MINUTE(expression)
```

The schema is SYSIBM.

The argument must be an expression that returns a value of one of the following built-in data types: a time, a timestamp, a character string, a graphic string, or a numeric data type.

- If *expression* is a character or graphic string, it must not be a CLOB or DBCLOB, and its value must be a valid string representation of a time or timestamp with an actual length of not greater than 255 bytes. For the valid formats of string representations of times and timestamps, see [“String representations of datetime values”](#) on page 120.
- If *expression* is a number, it must be a time or timestamp duration. For the valid formats of time and timestamp durations, see [“Datetime operands”](#) on page 169"/>.

If *expression* is a timestamp with a time zone, or a valid string representation of a timestamp with a time zone, the result is determined from the UTC representation of the datetime value.

The result of the function is a large integer.

The result can be null; if the argument is null, the result is the null value.

The other rules depend on the data type of the argument:

If the argument is a time, timestamp, or string representation of either, the result is the minute part of the value, which is an integer in the range 0–59.

If the argument is a time duration or timestamp duration, the result is the minute part of the value, which is an integer between -99 and 99. A nonzero result has the same sign as the argument.

If the argument contains a time zone, the result is the minute part of the value expressed in UTC.

Examples

Example 1

Assume that a table named CLASSES contains one row for each scheduled class. Assume also that the class starting times are in the TIME column named STARTTM. Using these assumptions, select those rows in CLASSES that represent classes that start on the hour.

```
SELECT * FROM CLASSES
WHERE MINUTE(STARTTM) = 0;
```

Example 2

Each invocation of the MINUTE function in the following SELECT statement returns the same result, which is 10.

```
SELECT MINUTE('2003-01-02-20.10.05.123456'),
       MINUTE('2003-01-02-12.10.05.123456-08:00'),
       MINUTE('2003-01-03-05.10.05.123456+09:00')
FROM SYSIBM.SYSDUMMY1;
```

When the input argument contains a time zone, the result is determined from the UTC representation of the input value. The string representations of a timestamp with a time zone in the SELECT statement all have the same UTC representation: 2003-01-02-20.10.05.123456. The minute portion of the UTC representation is 10.

MOD scalar function

The MOD function divides the first argument by the second argument and returns the remainder.

► MOD(*numeric-expression-1*, *numeric-expression-2*) ◄

The schema is SYSIBM.

The formula used to calculate the remainder is:

$$\text{MOD}(x,y) = x - \text{FLOOR}(x/y) * y$$

Where x/y is the truncated integer result of the division. The result is negative only if the first argument is negative.

Each argument must be an expression that returns a value of any built-in numeric data type.

The arguments can also be a character string or graphic string data type. The string input is implicitly cast to a numeric value of DECFLOAT(34).

The result can be null; if any argument is null, the result is the null value.

The attributes of the result are based on the arguments as follows:

- If both arguments are large or small integers, the data type of the result is large integer.
- If both arguments are integers and at least one argument is a big integer, the data type of the result is big integer.
- If one argument is an integer and the other is a decimal, the data type of the result is decimal with the same precision and scale as the decimal argument.
- If both arguments are decimal, the data type of the result is decimal. The precision of the result is $\min(p-s, p'-s') + \max(s, s')$, and the scale of the result is $\max(s, s')$, where the symbols p and s denote the precision and scale of the first argument, and the symbols p' and s' denote the precision and scale of the second argument.
- If one argument is a floating-point number, and the other is not a DECFLOAT, or both argument is a floating-point number, the data type of the result is double precision floating-point.

The operation is performed in floating-point. If necessary, the operands are first converted to double precision floating-point numbers. For example, an operation that involves a floating-point number and either an integer or a decimal number is performed with a temporary copy of the integer or decimal number that has been converted to double precision floating-point. The result of a floating-point operation must be within the range of floating-point numbers.

- If either argument is a DECFLOAT, the data type of the result is DECFLOAT(34).

If either argument is a special decimal floating point value, the general rules for arithmetic operations apply. For more information, see [“General arithmetic operation rules for DECFLOAT”](#) on page 254.

If one argument is a DECFLOAT and the second argument is zero, the result is NaN and an invalid operation condition is returned.

Example: Assume that $M1$ and $M2$ are two host variables. Find the remainder of dividing $M1$ by $M2$.

```
SELECT MOD(:M1, :M2)
FROM SYSIBM.SYSDUMMY1;
```

The following table shows the result for this function for various values of $M1$ and $M2$.

<i>M1</i> data type	<i>M1</i> value	<i>M2</i> data type	<i>M2</i> value	Result of MOD(:M1, :M2)
INTEGER	5	INTEGER	2	1
INTEGER	5	DECIMAL(3,1)	2.2	0.6
INTEGER	5	DECIMAL(3,2)	2.20	0.60
DECIMAL(4,2)	5.50	DECIMAL(4,1)	2.0	1.50
DECFLOAT	1	DECFLOAT	-INFINITY	1
DECFLOAT	-0	DECFLOAT	INFINITY	-0
DECFLOAT	-0	DECFLOAT	-INFINITY	-0

MONTH scalar function

The MONTH function returns the month part of a value.

► MONTH(*expression*) ◄

The schema is SYSIBM.

The argument must be an expression that returns one of the following built-in data types: a date, a timestamp, a character string, a graphic string, or a numeric data type.

- If *expression* is a character or graphic string, it must not be a CLOB or DBCLOB, and its value must be a valid string representation of a date or timestamp with an actual length of not greater than 255 bytes. For the valid formats of string representations of dates and timestamps, see [“String representations of datetime values”](#) on page 120.
- If *expression* is a number, it must be a date or timestamp duration. For the valid formats of date and timestamp durations, see [“Datetime operands”](#) on page 169.

If *expression* is a timestamp with a time zone, or a valid string representation of a timestamp with a time zone, the result is determined from the UTC representation of the datetime value.

The result of the function is a large integer.

The result can be null; if the argument is null, the result is the null value.

The other rules depend on the data type of the argument:

If the argument is a date, timestamp, or string representation of either, the result is the month part of the value, which is an integer in the range 1–12.

If the argument is a date duration or timestamp duration, the result is the month part of the value, which is an integer between -99 and 99. A nonzero result has the same sign as the argument.

If the argument contains a time zone, the result is the month part of the value expressed in UTC.

Example 1: Select all rows in the sample table DSN8C10.EMP for employees who were born in May:

```
SELECT * FROM DSN8C10.EMP
WHERE MONTH(BIRTHDATE) = 5;
```

Example 2: The following invocations of the MONTH function returns the same result:

```
SELECT MONTH('2003-01-02-20.10.05.123456'),
       MONTH('2003-01-02-12.10.05.123456-08:00'),
       MONTH('2003-01-03-05.10.05.123456+09:00')
FROM SYSIBM.SYSDUMMY1;
```

For each invocation of the MONTH function in this SELECT statement, the result is 1.

When the input argument contains a time zone, the result is determined from the UTC representation of the input value. The string representations of a timestamp with a time zone in the SELECT statement all have the same UTC representation: 2003-01-02-20.10.05.123456. The month portion of the UTC representation is 1.

MONTHS_BETWEEN scalar function

The MONTHS_BETWEEN function returns an estimate of the number of months between two arguments.

► MONTHS_BETWEEN(*expression1*,*expression2*) ◄

The schema is SYSIBM.

expression1 or expression2

Expressions that return a value of any of the following built-in data types: a date, a timestamp, a character string, or a graphic string. If either expression is a character or graphic string, it must not be a CLOB or DBCLOB, and its value must be a valid string representation of a date or timestamp with an actual length that is not greater than 255 bytes. A time zone in a string representation of a timestamp is ignored. For the valid formats of string representations of dates and timestamps, see [“String representations of datetime values” on page 120](#).

If *expression1* is a `TIMESTAMP WITH TIME ZONE` value, *expression1* is first cast to `TIMESTAMP WITHOUT TIME ZONE` with the same precision as *expression1*. If *expression2* is a `TIMESTAMP WITH TIME ZONE` value, *expression2* is first cast to `TIMESTAMP WITHOUT TIME ZONE` with the same precision as *expression2*.

If *expression1* represents a date that is later than *expression2*, the result is positive. If *expression1* represents a date that is earlier than *expression2*, the result is negative.

- If *expression1* and *expression2* represent dates or timestamps with the same day of the month, or both arguments represent the last day of their respective months, the result is a the whole number difference based on the year and month values, ignoring any time portions of timestamp arguments.
- Otherwise, the whole number part of the result is the difference based on the year and month values. The fractional part of the result is calculated from the remainder based on an assumption that every month has 31 days. If either argument represents a timestamp, the arguments are effectively processed as timestamps with maximum precision, and the time portions of these values are also considered when determining the result.

The result of the function is a `DECIMAL(31,15)`.

The result can be null; if any argument is null, the result is the null value.

Examples 1: The following example calculates the months between two dates:

```
SELECT MONTHS_BETWEEN ('2008-01-17', '2008-02-17')
       AS MONTHS_BETWEEN
FROM SYSIBM.SYSDUMMY1;
```

The results of this statement are similar to the following results:

```
MONTHS_BETWEEN
-----
-1.000000000000000
```

Examples 2: The following example calculates the months between two dates:

```
SELECT MONTHS_BETWEEN ('2008-02-20', '2008-01-17')
       AS MONTHS_BETWEEN
FROM SYSIBM.SYSDUMMY1;
```

The results of this statement are similar to the following results:

```
MONTHS_BETWEEN
-----
1.096774193548387
```

Example 3: Calculate the number of months that project AD3100 will take. Assume that the start date is 1982-01-01 and the end date is 1983-02-01:

```
SELECT MONTHS_BETWEEN (PRENDATE, PRSDATE)
       FROM PROJECT
       WHERE PROJNO='AD3100';
```

The result is 13.000000000000000.

Example 4: The following table illustrates the use of the `MONTHS_BETWEEN` function in certain situations:

Table 79. Additional examples using MONTHS_BETWEEN

Value for <i>expression1</i>	Value for <i>expression2</i>	Value returned by MONTHS_BETWEEN (<i>expression1</i> , <i>expression2</i>)	Value returned by ROUND (MONTHS_BETWEEN (<i>expression1</i> , <i>expression2</i>)*31,2)
2005-02-02	2005-01-01	1.032258064516129	32.00
2007-11-01-09.00.00.00000	2007-12-07-14.30.12.12345	-1.200945386592741	-37.23
2007-12-13-09.40.30.00000	2007-11-13-08.40.30.00000	1.000000000000000 ¹	31.00 ¹
2007-03-15	2007-02-20	0.838709677419354 ²	26.00 ²
2008-02-29	2008-02-28-12.00.00	0.016129032258064	0.50
2008-03-29	2008-02-29	1.000000000000000	31.00
2008-03-30	2008-02-29	1.032258064516129	32.00
2008-03-31	2008-02-29	1.000000000000000 ³	31.00 ³

Notes:

1. The time difference is ignored because the day of the month is the same for both values.
2. The result is not 23 because, even though February has 28 days, the assumption is that all months have 31 days.
3. The result is not 33 because both dates are the last day of their respective month, and so the result is only based on the year and month portions.

MQREAD scalar function

The MQREAD function returns a message from a specified IBM MQ location without removing the message from the queue.

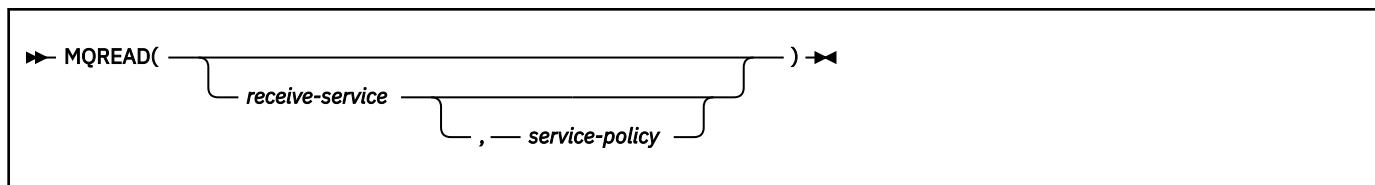

The schema is DB2MQ.

The MQREAD function returns a message from the IBM MQ location that is specified by *receive-service*, using the quality-of-service policy that is defined in *service-policy*. Performing this operation does not remove the message from the queue that is associated with *receive-service*, but instead returns the message at the beginning of the queue.

receive-service

An expression that returns a value that is a built-in character string or graphic string data type that is not a LOB. The value of the expression must not be an empty string or a string with trailing blanks. The expression must have an actual length that is no greater than 48 bytes. The value of the expression must refer to a service point that is defined in the DB2MQ.MQSERVICE table. A service point is a logical end-point from which a message is sent or received. A service point definition includes the name of the IBM MQ queue manager and the name of the queue. See *IBM MQ Application Messaging Interface* for more details.

If *receive-service* is not specified or is the null value, DB2 . DEFAULT . POLICY is used.

service-policy

An expression that returns a value that is a built-in character string or graphic string data type that is not a LOB. The value of the expression must not be an empty string or a string with trailing blanks. The expression must have an actual length that is no greater than 48 bytes. The value of the expression must refer to a service policy that is defined in the DB2MQ.MQPOLICY table. A service policy specifies a set of quality-of-service options that are to be applied to this messaging operation. These options include message priority and message persistence. See *IBM MQ Application Messaging Interface* for more details.

If *service-policy* is not specified or is the null value, DB2 . DEFAULT . POLICY is used.

The result of the function is a varying-length string with a length attribute of 4000. The result can be null. If no messages are available to be returned, the result is the null value.

The CCSID of the result is the system CCSID that was in effect at the time that the IBM MQ function was installed into Db2.

Examples

Example 1: Retrieve the message at the beginning of the queue that is specified by the default service (Db2.DEFAULT.SERVICE), using the default policy (Db2.DEFAULT.POLICY)

```
SELECT MQREAD()  
FROM SYSIBM.SYSDUMMY1;
```

The message at the beginning of the queue specified by the default server and using the default policy is returned as VARCHAR(4000).

Example 2: Read the message from the beginning of the queue specified by the service MYSERVICE, using the default policy (Db2.DEFAULT.POLICY)

```
SELECT MQREAD('MYSERVICE')  
FROM SYSIBM.SYSDUMMY1;
```

The message at the beginning of the queue specified by MYSERVICE and using Db2.DEFAULT.POLICY is returned as VARCHAR(4000).

Example 3: Read the message from the beginning of the queue specified by the service MYSERVICE, using the policy MYPOLICY

```
SELECT MQREAD('MYSERVICE', 'MYPOLICY')  
FROM SYSIBM.SYSDUMMY1;
```

The message at the beginning of the queue specified by MYSERVICE and using the policy MYPOLICY is returned as VARCHAR(4000).

MQREADCLOB scalar function

The MQREADCLOB function returns a message from a specified IBM MQ location without removing the message from the queue.

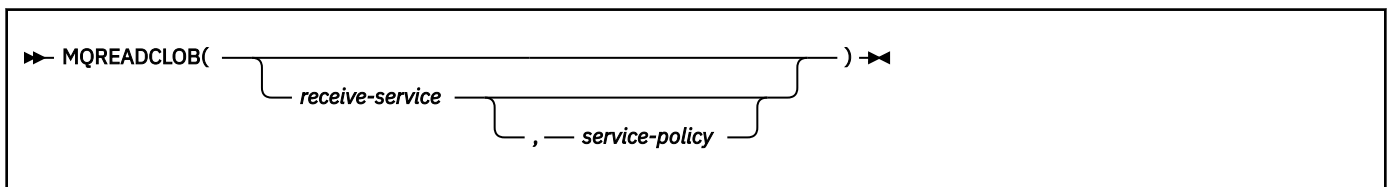

The schema is DB2MQ.

The MQREADCLOB function returns a message from the IBM MQ location that is specified by *receive-service*, using the quality-of-service policy that is defined in *service-policy*. Performing this operation does not remove the message from the queue that is associated with *receive-service*, but instead returns the message at the beginning of the queue.

receive-service

An expression that returns a value that is a built-in character string or graphic string data type that is not a LOB. The value of the expression must not be an empty string or a string with trailing blanks. The expression must have an actual length that is no greater than 48 bytes. The value of the expression must refer to a service point that is defined in the DB2MQ.MQSERVICE table. A service point is a logical end-point from which a message is sent or received. A service point definition includes the name of the IBM MQ queue manager and the name of the queue. See *IBM MQ Application Messaging Interface* for more details.

If *receive-service* is not specified or is the null value, DB2 . DEFAULT . POLICY is used.

service-policy

An expression that returns a value that is a built-in character string or graphic string data type that is not a LOB. The value of the expression must not be an empty string or a string with trailing blanks. The expression must have an actual length that is no greater than 48 bytes. The value of the expression must refer to a service policy that is defined in the DB2MQ.MQPOLICY table. A service policy specifies a set of quality-of-service options that are to be applied to this messaging operation. These options include message priority and message persistence. See *IBM MQ Application Messaging Interface* for more details.

If *service-policy* is not specified or is the null value, DB2 . DEFAULT . POLICY is used.

The result of the function is a CLOB with a length attribute of 1 MB. The result can be null. If no messages are available to be returned, the result is the null value.

The CCSID of the result is the system CCSID that was in effect at the time that the IBM MQ function was installed into Db2.

Examples

Example 1: Read the message from the beginning of the queue specified by the default service (Db2.DEFAULT.SERVICE), using the default policy (Db2.DEFAULT.POLICY)

```
SELECT MQREADCLOB()  
FROM SYSIBM.SYSDUMMY1;
```

The message at the beginning of the queue specified by the default service and using the default policy is returned as a CLOB.

Example 2: Read the message from the beginning of the queue specified by the service MYSERVICE, using the default policy (Db2.DEFAULT.POLICY)

```
SELECT MQREADCLOB('MYSERVICE')  
FROM SYSIBM.SYSDUMMY1;
```

The message at the beginning of the queue specified by MYSERVICE and using the default policy is returned as a CLOB.

Example 3: Read the message from the beginning of the queue specified by the service MYSERVICE, using the policy MYPOLICY

```
SELECT MQREADCLOB('MYSERVICE', 'MYPOLICY')  
FROM SYSIBM.SYSDUMMY1;
```

The message at the beginning of the queue specified by MYSERVICE and using the policy MYPOLICY is returned as a CLOB.

MQRECEIVE scalar function

The MQRECEIVE function returns a message from a specified IBM MQ location and removes the message from the queue.

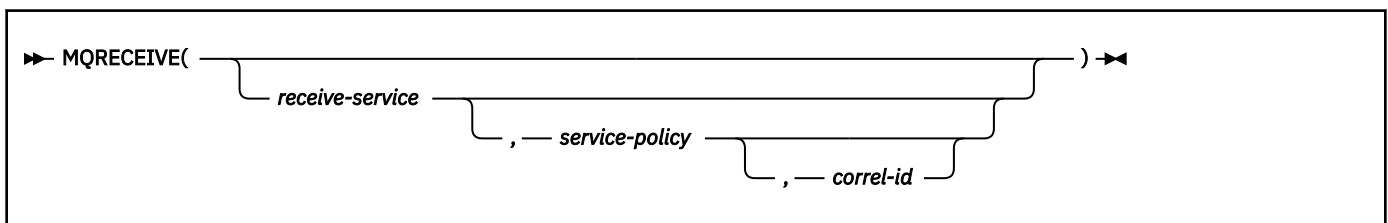

The schema is DB2MQ.

The MQRECEIVE function returns a message from the IBM MQ location specified by *receive-service*, using the quality-of-service policy defined in *service-policy*. Performing this operation removes the message from the queue that is associated with *receive-service*.

receive-service

An expression that returns a value that is a built-in character string or graphic string data type that is not a LOB. The value of the expression must not be an empty string or a string with trailing blanks. The expression must have an actual length that is no greater than 48 bytes. The value of the expression must refer to a service point that is defined in the DB2MQ.MQSERVICE table. A service point is a logical end-point from which a message is sent or received. A service point definition includes the name of the IBM MQ queue manager and the name of the queue. See *IBM MQ Application Messaging Interface* for more details.

If *receive-service* is not specified or is the null value, DB2 . DEFAULT . POLICY is used.

service-policy

An expression that returns a value that is a built-in character string or graphic string data type that is not a LOB. The value of the expression must not be an empty string or a string with trailing blanks. The expression must have an actual length that is no greater than 48 bytes. The value of the expression must refer to a service policy that is defined in the DB2MQ.MQPOLICY table. A service policy specifies a set of quality-of-service options that are to be applied to this messaging operation. These options include message priority and message persistence. See *IBM MQ Application Messaging Interface* for more details.

If *service-policy* is not specified or is the null value, DB2 . DEFAULT . POLICY is used.

correl-id

An expression that returns a value that is a built-in character string or graphic string data type that is not a LOB. The expression must have an actual length that is no greater than 24 bytes. The value of the expression specifies the correlation identifier that is associated with this message. A correlation identifier is often specified in request-and-reply scenarios to associate requests with replies. Only those messages with a matching correlation identifier are returned.

A fixed length string with trailing blanks is considered a valid value. However, when the *correl-id* is specified on another request such as MQSEND, the *correl-id* must be specified the same to be recognized as a match. For example, specifying a value of 'test' for *correl-id* for this function does not match a *correl-id* value of 'test ' (with trailing blanks) specified earlier on an MQSEND request.

If *correl-id* is not specified, is an empty string, or is the null value, a correlation identifier is not used, and the message at the beginning of the queue is returned.

The result of the function is a varying-length string of length attribute of 4000. The result can be null. The result is null if no messages are available to return.

The CCSID of the result is the system CCSID that was in effect at the time that the IBM MQ function was installed into Db2.

Examples

Example 1: Retrieve the message from beginning of the queue specified by the default service (Db2.DEFAULT.SERVICE), using the default policy (Db2.DEFAULT.POLICY)

```
SELECT MQRECEIVE()  
FROM SYSIBM.SYSDUMMY1;
```

The message at the beginning of the queue is returned as VARCHAR(4000) and is deleted from the queue. The queue is specified by the default service and using the default policy.

Example 2: Retrieve the first message from the beginning of the queue specified by the service MYSERVICE, using the default policy, Db2.DEFAULT.POLICY

```
SELECT MQRECEIVE('MYSERVICE')  
FROM SYSIBM.SYSDUMMY1;
```

The message at the beginning of the queue is returned as VARCHAR(4000) and is deleted from the queue. The queue is specified by the service MYSERVICE using the default policy, Db2.DEFAULT.POLICY.

Example 3: Retrieve the message from the beginning of the queue specified by the service MYSERVICE, using the policy MYPOLICY

```
SELECT MQRECEIVE('MYSERVICE', 'MYPOLICY')
FROM SYSIBM.SYSDUMMY1;
```

The message at the beginning of the queue is returned as VARCHAR(4000) and the message is deleted from the queue. The queue is specified by the service MYSERVICE using the policy MYPOLICY.

Example 4: Retrieve the first message with a correlation identifier that matches '1234' from the beginning of the queue specified by the service MYSERVICE, using the policy MYPOLICY.

```
SELECT MQRECEIVE('MYSERVICE', 'MYPOLICY', '1234')
FROM SYSIBM.SYSDUMMY1;
```

The first message with CORRELID of '1234' from the beginning of the queue is returned as VARCHAR(4000) and is deleted from the queue. The queue is specified by MYSERVICE and using MYPOLICY.

MQRECEIVECLOB scalar function

The MQRECEIVECLOB function returns a message from a specified IBM MQ location and removes the message from the queue.

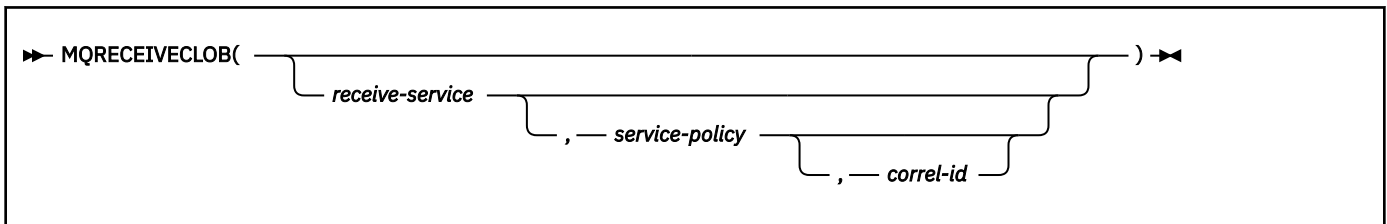

The schema is DB2MQ.

The MQRECEIVECLOB function returns a message from the IBM MQ location that is specified by *receive-service*, using the quality-of-service policy that is defined in *service-policy*. Performing this operation removes the message from the queue that is associated with *receive-service*.

receive-service

An expression that returns a value that is a built-in character string or graphic string data type that is not a LOB. The value of the expression must not be an empty string or a string with trailing blanks. The expression must have an actual length that is no greater than 48 bytes. The value of the expression must refer to a service point that is defined in the DB2MQ.MQSERVICE table. A service point is a logical end-point from which a message is sent or received. A service point definition includes the name of the IBM MQ queue manager and the name of the queue. See *IBM MQ Application Messaging Interface* for more details.

If *receive-service* is not specified or is the null value, DB2.DEFAULT.POLICY is used.

service-policy

An expression that returns a value that is a built-in character string or graphic string data type that is not a LOB. The value of the expression must not be an empty string or a string with trailing blanks. The expression must have an actual length that is no greater than 48 bytes. The value of the expression must refer to a service policy that is defined in the DB2MQ.MQPOLICY table. A service policy specifies a set of quality-of-service options that are to be applied to this messaging operation. These options include message priority and message persistence. See *IBM MQ Application Messaging Interface* for more details.

If *service-policy* is not specified or is the null value, DB2.DEFAULT.POLICY is used.

correl-id

An expression that returns a value that is a built-in character string or graphic string data type that is not a LOB. The expression must have an actual length that is no greater than 24 bytes. The value of the expression specifies the correlation identifier that is associated with this message. A correlation identifier is often specified in request-and-reply scenarios to associate requests with replies. Only those messages with a matching correlation identifier are returned.

A fixed length string with trailing blanks is considered a valid value. However, when the *correl-id* is specified on another request such as MQSEND, the *correl-id* must be specified the same to be recognized as a match. For example, specifying a value of 'test' for *correl-id* for this function does not match a *correl-id* value of 'test ' (with trailing blanks) specified earlier on an MQSEND request.

If *correl-id* is not specified, is an empty string, or is the null value, a correlation identifier is not used, and the message at the beginning of the queue is returned.

The result of the function is a CLOB with a length attribute of 1 MB. The result can be null. If no messages are available to be returned, the result is the null value.

The CCSID of the result is the system CCSID that was in effect at the time that the IBM MQ function was installed into Db2.

Examples

Example 1: Retrieve the message from the beginning of the queue specified by the default service (Db2.DEFAULT.SERVICE), using the default policy (Db2.DEFAULT.POLICY)

```
SELECT MQRECEIVECLOB()  
FROM SYSIBM.SYSDUMMY1;
```

The message at the beginning of the queue is returned as a CLOB and is deleted from the queue. The queue is specified by the default service and using the default policy.

Example 2: Retrieve the message from the beginning of the queue specified by the service MYSERVICE, using the policy (Db2.DEFAULT.POLICY)

```
SELECT MQRECEIVECLOB('MYSERVICE')  
FROM SYSIBM.SYSDUMMY1;
```

The message at the beginning of the queue is returned as a CLOB and is deleted from the queue. The queue is specified by MYSERVICE and using the default policy.

Example 3: Retrieve the message from the beginning of the queue specified by the service MYSERVICE, using the policy MYPOLICY

```
SELECT MQRECEIVECLOB('MYSERVICE', 'MYPOLICY')  
FROM SYSIBM.SYSDUMMY1;
```

The message at the beginning of the queue is returned as a CLOB and is deleted from the queue. The queue is specified by MYSERVICE and using the policy MYPOLICY.

Example 4: Retrieve the first message from the beginning of the queue with a correlation identifier that matches '1234' from the queue specified by the service MYSERVICE, using the policy MYPOLICY

```
SELECT MQRECEIVECLOB('MYSERVICE', 'MYPOLICY', '1234')  
FROM SYSIBM.SYSDUMMY1;
```

The first message at the beginning of the queue with a correlation identifier with '1234' is returned as a CLOB and is deleted from the queue. The queue is specified by MYSERVICE and using the policy MYPOLICY.

MQSEND scalar function

The MQSEND function sends data to a specified IBM MQ location.

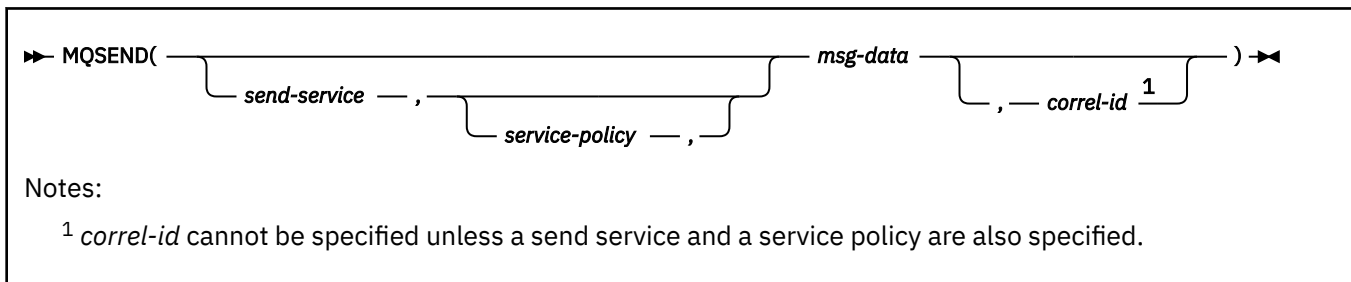

The schema is DB2MQ.

The MQSEND function sends the data that is contained in *msg-data* to the IBM MQ location that is specified by *send-service*, using the quality-of-service policy that is defined in *service-policy*.

send-service

An expression that returns a value that is a built-in character string or graphic string data type that is not a LOB. The value of the expression must not be an empty string or a string with trailing blanks. The expression must have an actual length that is no greater than 48 bytes. The value of the expression must refer to a service point that is defined in the DB2MQ.MQSERVICE table. A service point is a logical end-point from which a message is sent or received. A service point definition includes the name of the IBM MQ queue manager and the name of the queue.

If *send-service* is not specified or is the null value, Db2.DEFAULT.SERVICE is used.

service-policy

An expression that returns a value that is a built-in character string or graphic string data type that is not a LOB. The value of the expression must not be an empty string or a string with trailing blanks. The expression must have an actual length that is no greater than 48 bytes. The value of the expression must refer to a service policy that is defined in the DB2MQ.MQPOLICY table. A service policy specifies a set of quality-of-service options that are to be applied to this messaging operation. These options include message priority and message persistence. See *IBM MQ Application Messaging Interface* for more details.

If *service-policy* is not specified or is the null value, DB2.DEFAULT.POLICY is used.

msg-data

An expression that returns a value that is a built-in character string data type. If the expression is a CLOB, the value must not be longer than 1 MB. Otherwise, the value must not be longer than 4000 bytes. The value of the expression is the message data that is to be sent through IBM MQ. A null value, an empty string, and a fixed length string with trailing blanks are all considered valid values.

correl-id

An expression that returns a value that is a built-in character string or graphic string data type that is not a LOB. The expression must have an actual length that is no greater than 24 bytes. The value of the expression specifies the correlation identifier that is associated with this message. A correlation identifier is often specified in request-and-reply scenarios to associate requests with replies. *correl-id* must not be specified unless *send-service* and *service-policy* are also specified.

A fixed length string with trailing blanks is considered a valid value. However, when the *correl-id* is specified on another request such as MQRECEIVE, the *correl-id* must be specified the same to be recognized as a match. For example, specifying a value of 'test' for *correl-id* on MQSEND does not match a *correl-id* value of 'test ' (with trailing blanks) specified subsequently on an MQRECEIVE request.

If *correl-id* is not specified, is an empty string, or is the null value, a correlation identifier is not sent.

The returned value is a varying-length character string with the value '1' if function execution was successful, or an error message if function execution was unsuccessful.

The CCSID of the result is the system CCSID that was in effect at the time that the IBM MQ function was installed into Db2.

Notes

The application needs to check the SQLCODE after issuing the MQSEND function. If the SQLCODE is not 0, the application needs to retrieve and handle the returned error message.

Examples

Example 1: Send the string "Testing msg" to the default service (Db2.DEFAULT.SERVICE), using the default policy (Db2.DEFAULT.POLICY) and no correlation identifier

```
SELECT MQSEND('Testing msg')
FROM SYSIBM.SYSDUMMY1;
```

The message is sent to the default service, using the default policy.

Example 2: Send the message 'Testing 345' to the service MYSERVICE, using the policy MYPOLICY, with no correlation identifier

```
SELECT MQSEND('MYSERVICE','MYPOLICY','Testing 345')
FROM SYSIBM.SYSDUMMY1;
```

The message 'Testing 345' is sent to the MYSERVICE service, using the policy MYPOLICY.

Example 3: Send the message 'Testing 123' to the service MYSERVICE, using the policy MYPOLICY and the correlation identifier 'TEST3'

```
SELECT MQSEND('MYSERVICE','MYPOLICY','Testing 123','TEST3')
FROM SYSIBM.SYSDUMMY1;
```

The message 'Testing 123' is sent to the service MYSERVICE, using the policy MYPOLICY and the correlation identifier "TEST3".

Example 4: Send the message 'Testing 901' to the service "MYSERVICE", using the default policy (Db2.DEFAULT.POLICY), and no correlation identifier

```
SELECT MQSEND('MYSERVICE','Testing 901')
FROM SYSIBM.SYSDUMMY1;
```

The message 'Testing 901' is sent to the service MYSERVICE, using the default policy (Db2.DEFAULT.POLICY).

MULTIPLY_ALT scalar function

The MULTIPLY_ALT scalar function returns the product of the two arguments. This function is an alternative to the multiplication operator and is especially useful when the sum of the precisions of the arguments exceeds 31.

►► MULTIPLY_ALT(*exact-numeric-expression-1* ,*exact-numeric-expression-2*) ◄◄

The schema is SYSIBM.

Each argument must be an expression that returns the value of one of the following built-in numeric data types: DECIMAL, BIGINT, INTEGER, or SMALLINT.

The result of the function is a DECIMAL. The precision and scale of the result are determined as follows, using the symbols p and s to denote the precision and scale of the first argument, and the symbols p' and s' to denote the precision and scale of the second argument.

- The precision is $\text{MIN}(31, p+p')$
- The scale is:

- 0 if the scale of both arguments is 0
- $\text{MIN}(31, s+s')$ if $p+p'$ is less than or equal to 31
- $\text{MAX}(\text{MIN}(3, s+s'), 31-(p-s+p'-s'))$ if $p+p'$ is greater than 31.

The result can be null; if any argument is null, the result is the null value.

The MULTIPLY_ALT function is a better choice than the multiplication operator when performing decimal arithmetic where you want a scale of at least 3 and the sum of the precisions exceeds 31. In these cases, the internal computation is performed so that overflows are avoided and then assigned to the result type value using truncation for any loss of scale in the final result. Note that the possibility of overflow of the final result is still possible when the scale is 3.

The following table compares the result data types from the MULTIPLY_ALT function with the result data type of the multiplication operator when decimal data is used:

Type of Argument1	Type of Argument2	Result using MULTIPLY_ALT	Result using multiplication operator
DECIMAL(31,3)	DECIMAL(15,8)	DECIMAL(31,3)	DECIMAL(31,11)
DECIMAL(26,23)	DECIMAL(10,1)	DECIMAL(31,19)	DECIMAL(31,24)
DECIMAL(18,17)	DECIMAL(20,19)	DECIMAL(31,29)	DECIMAL(31,31)
DECIMAL(16,3)	DECIMAL(17,8)	DECIMAL(31,9)	DECIMAL(31,11)
DECIMAL(26,5)	DECIMAL(11,0)	DECIMAL(31,3)	DECIMAL(31,5)
DECIMAL(21,1)	DECIMAL(15,1)	DECIMAL(31,2)	DECIMAL(31,2)

Example

The following example multiplies two values where the data type of the first argument is DECIMAL(26,3) and the data type of the second argument is DECIMAL(9,8). The data type of the result is DECIMAL(31,7).

```
SELECT MULTIPLY_ALT(98765432109876543210987.654, 5.43210987)
FROM SYSIBM.SYSDUMMY1
```

The result is 536504678578875294857887.5277415.

The complete product of these two numbers is 536504678578875294857887.52774154498, but the last 4 digits are truncated to match the scale of the result data type. Using the multiplication operator with the same values will cause an arithmetic overflow, since the result data type is DECIMAL(31,11) and the result value has 24 digits left of the decimal, but the result data type only supports 20 digits.

NEXT_DAY scalar function

The NEXT_DAY function returns a datetime value that represents the first weekday, named by *string-expression*, that is later than the date in *expression*.

►► NEXT_DAY(*expression*, *string-expression*) ◄◄

The schema is SYSIBM.

If *expression* is a timestamp or valid string representation of a timestamp, the timestamp value has the same hours, minutes, seconds, and partial seconds as *expression*. If *expression* is a date, or a valid string representation of a date, then the hours, minutes, seconds, and partial seconds value of the result is 0.

expression

An expression that returns one of the following built-in data types: a date, a timestamp, a character string, or a graphic string. If *expression* is a character or graphic string, it must not be a CLOB or DBCLOB, and its value must be a valid string representation of a date or timestamp with an actual

length of not greater than 255 bytes. A time zone in a string representation of a timestamp is ignored. For the valid formats of string representations of dates and timestamps, see [“String representations of datetime values”](#) on page 120.

If *expression* does not have data type `TIMESTAMP WITHOUT TIME ZONE`, *expression* is cast as follows:

- If *expression* is a `TIMESTAMP WITH TIME ZONE` value, *expression* is cast to `TIMESTAMP WITHOUT TIME ZONE`, with the same precision as *expression*.
- Otherwise, *expression* is cast to `TIMESTAMP(6) WITHOUT TIME ZONE`.

string-expression

An expression that returns a built-in character or graphic string data type that is not a LOB. For portability across the platforms, the value should compare equal to the full name of a day of the week or should compare equal to the abbreviation of a day of the week. For example:

Day of week	Abbreviation
MONDAY	MON
TUESDAY	TUE
WEDNESDAY	WED
THURSDAY	THU
FRIDAY	FRI
SATURDAY	SAT
SUNDAY	SUN

The minimum length of the input value is the length of the abbreviation. Leading blanks must not be specified in *string-expression*. Trailing blanks are trimmed from *string-expression*. The resulting value is folded to uppercase. Any characters other than blank that immediately follow a valid abbreviation are ignored.

If *expression* is a timestamp, the result is a `TIMESTAMP WITHOUT TIME ZONE` value with the same precision as *expression*. If *expression* is `DATE`, the result is a `DATE` value. Otherwise, the result is a `TIMESTAMP(6) WITHOUT TIME ZONE` value.

Any hours, minutes, seconds, or fractional seconds information that is included in *expression* is not changed by the function. If *expression* is a string that represents a date, the time information in the resulting timestamp value is all set to zero.

The result can be null; if any argument is null, the result is the null value.

The result CCSID is the appropriate CCSID of the argument encoding scheme and the result subtype is the appropriate subtype of the CCSID.

Example 1: Set the host variable `NEXTDAY` with a timestamp for the date of the Tuesday that follows April 24, 2007.

```
SET :NEXTDAY = NEXT_DAY(TIMESTAMP '2007-04-24-00.00.00.000000', 'TUESDAY');
```

The host variable `NEXTDAY` is set with the value of '2007-05-01-00.00.00.000000', since April, 24, 200 is itself a Tuesday!

Example 2: Set the host variable `vNEXTDAY` with the date of the first Monday in May, 2007. Assume the host variable `vDAYOFWEEK = 'MON'`:

```
SET :vNEXTDAY = NEXT_DAY(LAST_DAY(CURRENT_DATE), :vDAYOFWEEK);
```

The host variable `vNEXTDAY` is set with the value of '2007-05-07', assuming that the value of the `CURRENT_DATE` special register is '2007-04-24'.

NEXT_MONTH scalar function

The NEXT_MONTH function returns the first day of the next month after the specified date.

[FL 507](#)

Passthrough-only expression: This function is passthrough-only and cannot run on Db2 for z/OS without acceleration. For information about invoking this function, see [Accelerating queries with passthrough-only expressions](#).

►► NEXT_MONTH (— *datetime-expression* —) ◄◄

The schema is SYSIBM.

datetime-expression

An expression that specifies a date after which the first day of the next month is to be returned. The expression must return a value that is a DATE, TIMESTAMP WITHOUT TIME ZONE, CHAR, VARCHAR, GRAPHIC, or VARGRAPHIC data type. CHAR, VARCHAR, GRAPHIC, and VARGRAPHIC are supported using implicit casting. If *datetime-expression* is a CHAR, VARCHAR, GRAPHIC, or VARGRAPHIC data type, it must be a valid string accepted by the TIMESTAMP scalar function and does not contain a time zone.

The result of the function is DATE. If the argument can be null, the result can be null. If the argument is null, the result is the null value.

Examples

- The following example returns the date value of the first day of the next month after the date specified by the input:

```
values next_month('2007-02-18')
Result: 2007-03-01
```

NORMALIZE_DECFLOAT scalar function

The NORMALIZE_DECFLOAT function returns a DECFLOAT value that is the result of the argument, set to its simplest form. That is, a non-zero number that has any trailing zeros in the coefficient has those zeros removed by dividing the coefficient by the appropriate power of ten and adjusting the exponent accordingly. A zero has its exponent set to 0.

►► NORMALIZE_DECFLOAT(*decfloat-expression*) ◄◄

The schema is SYSIBM.

decfloat-expression

The argument must be an expression that returns a DECFLOAT value.

decfloat-expression can also be a character string or graphic string data type. The string input is implicitly cast to a numeric value of DECFLOAT(34).

If the argument is a special decimal floating point value then the general rules for arithmetic operations apply. For more information, see [“General arithmetic operation rules for DECFLOAT”](#) on page 254

The result of the function is a DECFLOAT(16) value if the data type of *decfloat-expression* is DECFLOAT(16). Otherwise, the result of the function is a DECFLOAT(34) value.

The result can be null; if the argument is null, the result is the null value.

Examples: The following examples show the result of using the NORMALIZE_DECFLOAT function on various DECFLOAT values:

```
NORMALIZE_DECFLOAT(DECFLOAT(2.1))           = 2.1
NORMALIZE_DECFLOAT(DECFLOAT(-2.0))          = -2
NORMALIZE_DECFLOAT(DECFLOAT(1.200))         = 1.2
NORMALIZE_DECFLOAT(DECFLOAT(-120))          = -1.2E+2
NORMALIZE_DECFLOAT(DECFLOAT(120.00))        = 1.2E+2
NORMALIZE_DECFLOAT(DECFLOAT(0.00))          = 0
NORMALIZE_DECFLOAT(-NAN)                    = -NAN
NORMALIZE_DECFLOAT(-INFINITY)               = -INFINITY
```

NORMALIZE_STRING scalar function

The NORMALIZE_STRING function takes a Unicode string argument and returns a normalized string that can be used for comparison.

The NORMALIZE_STRING function can convert two strings that look the same (such as Å, which can be encoded in UTF-16 as X'00C5' and as X'0041030a') but might not be encoded using the same Unicode code point, to a normalized form that can be compared.

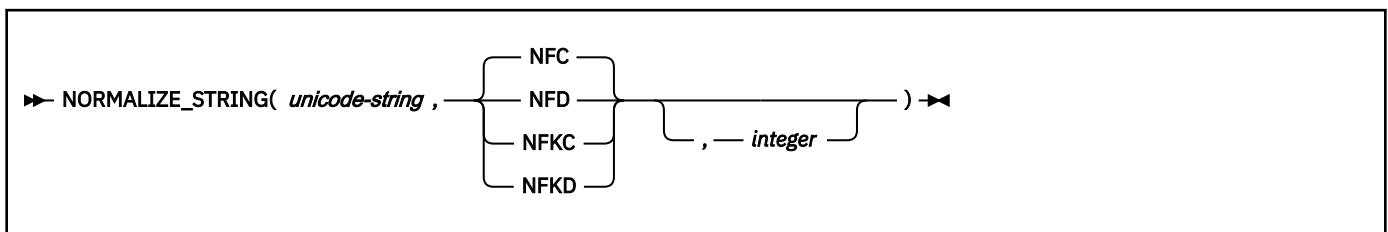

The schema is SYSIBM.

unicode_string

An expression that returns a value of a built-in character string or graphic string data type that is either Unicode UTF-8 or Unicode UTF-16, and is not a LOB. The CAST specification can be used to convert ASCII or EBCDIC data to Unicode for use with this function.

NFC, NFD, NFKC, or NFKD

Specifies the normalized form:

NFC

Canonical Decomposition followed by Canonical Composition

NFD

Canonical Decomposition

NFKC

Compatibility Decomposition followed by Canonical Composition

NFKD

Compatibility Decomposition

integer

The length attribute, in bytes if the string is a character string, or in double byte code points if the string is a graphic string, for the resulting variable length string. The value must be an integer in the range 1–32704 if the source string is character, or 16352 if the source string is graphic.

The result of the function is a varying length string with a data type that depends on the data type of *unicode-string*:

- VARCHAR if *unicode-string* is CHAR or VARCHAR
- VARGRAPHIC if *unicode-string* is GRAPHIC or VARGRAPHIC

The CCSID of the result is the same as the CCSID of *unicode-string*.

The length attribute of the result depends on whether *integer* is specified. If *integer* is specified, the length attribute of the result is *integer* bytes or double byte code points. If *integer* is not specified, the length

attribute of the result is $\text{MIN}(3 \times n, 32704)$ for character strings, or $\text{MIN}(3 \times n, 16352)$ for graphic strings, where n is the length attribute of the source.

The result can be null; if the first argument is null, the result is the null value.

Example 1: In the following example, "ábc" is normalized to normalization form NFC:

```
SET :hv1 = NORMALIZE_STRING('ábc',NFC) -- x'0061030100620063'
```

hv1 is set to 'ábc' -- X'00E100620063'. Using normalization form NFC, the two code-point sequence X'00610301', which represents the character 'á', is normalized to X'00E1' which is also the pre-composed equivalent of X'00610301'.

Example 2: In the following example, "ábc" is normalized to normalization form NFD.

```
SET :hv1 = NORMALIZE_STRING('ábc',NFD) -- x'00E100620063'
```

hv1 is set to 'ábc' -- X'0061030100620063'. Using normalization form NFD, the code point X'00E1' is decomposed into the two code-point sequence X'00610301', which consists of the Latin lower case letter A and the combining acute accent character.

NULLIF scalar function

The NULLIF function returns the null value if the two arguments are equal; otherwise, it returns the value of the first argument.

►► NULLIF(*expression,expression*) ◄◄

The schema is SYSIBM.

The two arguments must be compatible. The arguments can be of either a built-in or user-defined distinct type. Neither argument can be a BLOB, CLOB, DBCLOB, or XML. Character-string and graphic-string arguments are compatible with datetime values. For more information on compatibility, refer to the compatibility matrix in [Table 30 on page 144](#).

If there are any mixed character string or graphic string and numeric arguments, the string value is implicitly cast to a DECFLOAT(34) value.

The attributes of the result are the attributes of the first argument.

Notes

Syntax alternatives:

The result of using NULLIF(*e1,e2*) is the same as using the CASE expression:

```
CASE WHEN e1=e2 THEN NULL ELSE e1 END
```

When *e1=e2* evaluates to unknown because one or both arguments is null, CASE expressions consider the evaluation not true. In this case, NULLIF returns the value of the first argument.

Examples

Example 1:

Assume that host variables *PROFIT*, *CASH*, and *LOSSES* have decimal data types with the values of 4500.00, 500.00, and 5000.00 respectively. The following function returns a null value:

```
NULLIF (:PROFIT + :CASH , :LOSSES)
```

NVL scalar function

The NVL function returns the first argument that is not null.

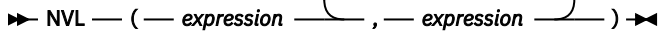

►► NVL — (— *expression* — , — *expression* —) ►►

The schema is SYSIBM.

The NVL function is identical to the COALESCE function. For more information, see [“COALESCE scalar function”](#) on page 417.

OVERLAY scalar function

The OVERLAY function returns a string that is composed of one argument that is inserted into another argument at the same position where some number of bytes have been deleted.

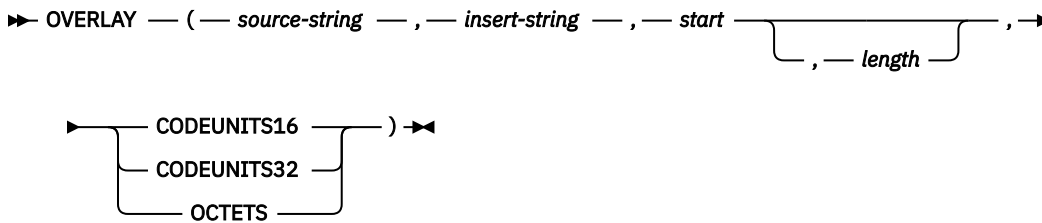

►► OVERLAY — (— *source-string* — , — *insert-string* — , — *start* — , — *length* —) ►►

CODEUNITS16
CODEUNITS32
OCTETS

The schema is SYSIBM.

The OVERLAY function returns a string where a substring of *length*, beginning at *start* has been deleted from *source-string*, and where *insert-string* has been inserted into *source-string* beginning at *start*. If the value of *start* plus *length* is greater than the length of *source-string*, the substring that is deleted is from *start* to the end of *source-string*.

If the length of the result string exceeds the maximum for the return type, an error is returned.

source-string

An expression that specifies the source string. The expression must return a value that is a built-in character string, graphic string, or binary string data type that is not a LOB.

The argument can also be a numeric data type. The numeric argument is implicitly cast to a VARCHAR data type.

The actual length of the string must be greater than or equal to 1 byte and less than or equal to 32704 bytes.

insert-string

An expression that specifies the string that is inserted into *source-string*, starting at the position that is identified by *start*. *insert-string* must return a value that is a built-in character string, graphic string, or binary string data type that is not a LOB. *source-string* and *insert-string* must have compatible data types.

The argument can also be a numeric data type. The numeric argument is implicitly cast to a VARCHAR data type.

start

An expression that returns an integer. The integer specifies the starting point within the source string where the deletion of bytes and the insertion of another string is to begin. The value of the integer must be in the range of 1 to the length of *source-string* plus one. If OCTETS is specified and the result is graphic data, the value must be an odd value between 1 and twice the length of *source-string* plus one.

The argument can also be a character string or graphic string data type. The string input is implicitly cast to a numeric value of DECFLOAT(34) which is then assigned to an INTEGER value.

length

An expression that specifies the length of the string to replace in *source-string* starting at *start*. *length* must be an expression that returns a value of the built-in INTEGER data type. *length* is expressed in the string unit specified, and the value must be in the range of 0 to the length of *source-string*. If OCTETS is specified and the result is graphic data, *length* must be even and be between 0 and twice the length of *source-string*. Not specifying *length* is equivalent to specifying a value of 1, except when OCTETS is specified and the result is graphic data, in which case, not specifying *length* is equivalent to specifying a value of 2.

The argument can also be a character string or graphic string data type. The string input is implicitly cast to a numeric value of DECFLOAT(34) which is then assigned to an INTEGER value.

CODEUNITS16, CODEUNITS32, or OCTETS

Specifies the units that are used to express *start* and *length* in the result. If *source-string* is a character string that is defined as bit data, CODEUNITS16 and CODEUNITS32 cannot be specified. If *source-string* is a graphic string, OCTETS cannot be specified. If *source-string* is a binary string, CODEUNITS16, CODEUNITS32, and OCTETS cannot be specified.

If a string unit is not explicitly specified, the data type of the result determines the unit that is used. If the result is a graphic string, a string unit is two bytes. For ASCII and EBCDIC data, this corresponds to a double byte character. For Unicode, this corresponds to a UTF-16 code point. Otherwise, a string unit is a byte.

CODEUNITS16

Specifies that *start* and *length* are expressed in terms of 16-bit UTF-16 code units.

CODEUNITS32

Specifies that *start* and *length* are expressed in terms of 32-bit UTF-32 code units.

OCTETS

Specifies that *start* and *length* are expressed in terms of bytes.

For more information about CODEUNITS16, CODEUNITS32, and OCTETS, see [“String unit specifications” on page 106](#). *length* must be an even number if *source-string* is graphic data and OCTETS is specified

If *source-string* and *insert-string* have different CCSID sets, *insert-string* (the string to be inserted) is converted to the CCSID of *source-string* (the source string).

The encoding scheme of the result is the same as *source-string*. The data type of the result of the function depends on the data type of *source-string* and *insert-string*:

- VARCHAR if *source-string* is a character string. The CCSID of the result depends on the arguments:
 - If either *source-string* or *insert-string* is character bit data, the result is bit data.
 - If both *source-string* and *insert-string* are SBCS:
 - If both *source-string* and *insert-string* are SBCS Unicode data, the CCSID of the result is the CCSID for SBCS Unicode data.
 - If *source-string* is SBCS Unicode data and *insert-string* is not SBCS Unicode data, the CCSID of the result is the mixed CCSID for Unicode data.
 - Otherwise, the CCSID of the result is the same as the CCSID of *source-string*.
 - Otherwise, the CCSID of the result is the mixed CCSID that corresponds to the CCSID of *source-string*. However, if the input is EBCDIC or ASCII and there is no corresponding system CCSID for mixed, the CCSID of the result is the CCSID of *source-string*.
- VARGRAPHIC if *source-string* is a graphic. The CCSID of the result is the same as the CCSID of *source-string*.
- VARBINARY if *source-string* and *insert-string* are both binary strings.

The length attribute of the result depends on the arguments:

- If *start* and *length* are constants, the length attribute of the result is:

$$L1 - \text{MIN}((L1 - V2 + 1), V3) + L4$$

where:

L1 is the length attribute of *source-string*

V2 is the value of *start*

V3 is the value of *length*

L4 is the length attribute of *insert-string*

- Otherwise, the length attribute of the result is the length attribute of *source-string* plus the length attribute of *insert-string*. In this case, the length attribute of *source-string* plus the length attribute of *insert-string* must not exceed 32704 for a VARCHAR result or 16352 for a VARCHARIC result.

If CODEUNITS16 or CODEUNITS32 is specified, the insert operation is performed on a Unicode version of the data. If needed, the data is converted to an intermediate form in order to evaluate the function. If an intermediate form is used, the actual length of the result depends on the original data (*source-string* and *insert-string*), and the representation of that data in Unicode. See “Determining the length attribute of the final result” on page 108 for more information on how to calculate the length attribute of the result string.

If CODEUNITS16 or CODEUNITS32 are not specified, the actual length of the result is:

$$A1 - \text{MIN}((A1 - V2 + 1), V3) + A4$$

where:

A1 is the actual length of *source-string*

V2 is the value of *start*

V3 is the value of *length*

A4 is the actual length of *insert-string*

If the actual length of the result string exceeds the maximum for the return data type, an error occurs.

The result can be null; if any argument is null, the result is the null value.

Notes

Syntax alternatives:

The OVERLAY function is similar to the INSERT function, except that the length argument is optional. For more information, see “INSERT scalar function” on page 480.

Examples

Example 1:

The following example shows how the string 'INSERTING' can be changed into other strings. The use of the CHAR function limits the length of the resulting string to 10 bytes.

```
SELECT CHAR(OVERLAY('INSERTING', 'IS', 4, 2, OCTETS), 10),
       CHAR(OVERLAY('INSERTING', 'IS', 4, 0, OCTETS), 10),
       CHAR(OVERLAY('INSERTING', '', 4, 2, OCTETS), 10)
FROM SYSIBM.SYSDUMMY1;
```

This example returns 'INSISTING ', 'INSISERTIN', and 'INSTING '.

Example 2:

Use the OVERLAY function to insert the character 'C' into the Unicode string '&N~AB', where '&' is the character for the musical symbol, G CLEF, and '~' is the character for combining tilde. The following table shows the Unicode string in different Unicode encoding forms:

Unicode format	&	N	~	A	B
UTF-8	X'F09D849E'	X'4E'	X'CC83'	X'41'	X'42'

Unicode format	&	N	~	A	B
UTF-16	X'D834DD1E'	X'004E'	X'0303'	X'0041'	X'0042'

Assume the host variable *UTF8_VAR* contains the UTF-8 representation of '&N~AB', and *UTF16_VAR* contains the UTF-16 representation of '&N~AB'. Then the following SELECT statement is run:

```
SELECT OVERLAY (:UTF8_VAR, 'C', 1, CODEUNITS16),
       OVERLAY (:UTF8_VAR, 'C', 1, CODEUNITS32),
       OVERLAY (:UTF8_VAR, 'C', 1, OCTETS)
FROM SYSIBM.SYSDUMMY1
```

This statement returns the following values:

```
C N~AB
CN~AB
C?N~AB -- ? is the invalid UTF-8 sequence X'9D849E'
```

Assume that the previous SELECT statement was not run, but the following SELECT statement is run:

```
SELECT OVERLAY (:UTF8_VAR, 'C', 5, CODEUNITS16),
       OVERLAY (:UTF8_VAR, 'C', 5, CODEUNITS32),
       OVERLAY (:UTF8_VAR, 'C', 5, OCTETS)
FROM SYSIBM.SYSDUMMY1;
```

This statement returns the values:

```
&N~CB
&N~AC
&C~AB
```

Assume that the previous SELECT statement was not run, but the following SELECT statement is run:

```
SELECT OVERLAY (:UTF16_VAR, 'C', 1, CODEUNITS16),
       OVERLAY (:UTF16_VAR, 'C', 1, CODEUNITS32)
FROM SYSIBM.SYSDUMMY1;
```

This statement returns the values:

```
C?N~AB
CN~AB
```

Assume that the previous SELECT statement was not run, but the following SELECT statement is run:

```
SELECT OVERLAY (:UTF16_VAR, 'C', 5, CODEUNITS16),
       OVERLAY (:UTF16_VAR, 'C', 5, CODEUNITS32),
FROM SYSIBM.SYSDUMMY1;
```

This statement returns the values:

```
&N~CB
&N~AC
```

PACK scalar function

The PACK function returns a binary string value that contains a data type array and a packed representation of each non-null *expression* argument.

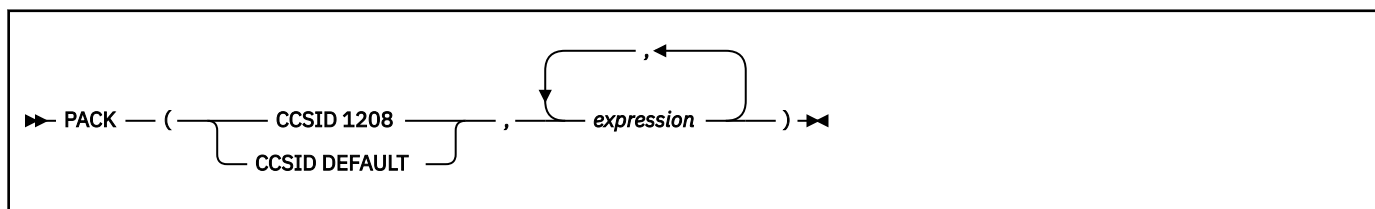

The schema is SYSIBM.

CCSID 1208

Specifies that CCSID 1208 is used to encode character string values.

CCSID DEFAULT

Specifies that character strings are to be packed in their original encoding, as-is, without CCSID conversion.

expression

An expression that returns a value to be encoded in the result string. The *expression* must be a built-in data type that is not DECFLOAT, GRAPHIC, VARGRAPHIC, ROWID, a LOB, XML, or a character string defined as FOR BIT DATA.

The result of the PACK function is a binary string that is constructed from the following items:

- A flag byte that is reserved for future use
- A 2-byte integer value that indicates the number of arguments encoded in the resulting string
- The data type array that contains an element with data type information for each of the encoded arguments
- The encoded values for the *expression* arguments in the order as specified in the function invocation.

The resulting binary string is formatted as follows:

2-byte length	Flag byte	Number of items	Data type array	Encoded data values
VARBINARY length	VARBINARY data			

The data type array includes an element for each *expression* argument in the same order as specified in the function invocation. Each array element contains a 2-byte SQLTYPE value that indicates the data type of the corresponding expression. When the SQLTYPE value is an odd number, the corresponding expression represents a null value and the value is not encoded in the resulting string. When the SQLTYPE value is an even number, the resulting string contains an encoded representation of the value depending on the data type. The following table describes the data types:

Data type of expression	Description of the encoded representation of the value in the resulting string
SMALLINT, INTEGER, or BIGINT	The value of expression as a 16-bit signed binary integer, 32-bit signed binary integer, or 64-bit signed binary integer depending on the data type
decimal(<i>p,s</i>) ¹	A sequence of 1-byte precision <i>p</i> , 1-byte scale <i>s</i> , and (<i>p</i> +2)/2 bytes of the signed packed-decimal number
real ² or double ³	The value of <i>expression</i> as a 64-bit IEEE floating-point format
CHAR or VARCHAR	A sequence of the 2-byte CCSID of the string encoding, followed by the 2-byte length of the string and then the argument data in the specified CCSID encoding
BINARY or VARBINARY	A sequence of: 2-byte length of the string, followed by the argument data
DATE	A 4-byte unsigned packed-decimal number representation of the date in the form of YYYYMMDD
TIME	A 3-byte unsigned packed-decimal number representation of the time in the form of HHMMSS

Table 80. Data types for the expression of the PACK function (continued)

Data type of expression	Description of the encoded representation of the value in the resulting string
TIMESTAMP(<i>p</i>) WITHOUT TIME ZONE	A sequence of a 2-byte unsigned binary integer value of the precision <i>p</i> , followed by $7 + (p+1)/2$ bytes of an unsigned packed-decimal number representation of the timestamp in the form of YYYYMMDDHHMMSSNN, where NN is zero to six bytes of the fractional seconds, depending on the precision <i>p</i>
TIMESTAMP(<i>p</i>) WITH TIME ZONE	A sequence of a 2-byte unsigned binary integer value of the precision <i>p</i> , followed by $7 + (p+1)/2$ bytes of an unsigned packed-decimal number representation of the timestamp in the form of YYYYMMDDHHMMSSNN, where NN is zero to six bytes of the fractional seconds, depending on the precision <i>p</i> , and then followed by 2 bytes of an unsigned packed-decimal number representation of the time zone (with high order bit set for negative time zone value)
<p>Note: The data types in lower case are defined as follows:</p> <ol style="list-style-type: none"> decimal = DECIMAL(<i>p,s</i>) or NUMERIC(<i>p,s</i>) real = REAL or FLOAT(<i>n</i>) where <i>n</i> is the specification for a single precision floating point double = DOUBLE, DOUBLE PRECISION, FLOAT or FLOAT(<i>n</i>) where <i>n</i> is the specification for a double precision floating point <p>The synonyms for the data types, in either long or short form, are considered the same as those that are listed.</p>	

All numeric data is represented in big endian format.

The result of the function is VARBINARY. The length attribute of the result is MIN (32704, the length of the header + length of data type array + SUM(maximum lengths of encoded expression values)). The result cannot be null.

Example 1: The following statement shows that the VARCHAR, DATE, and DOUBLE values are packed into a binary string, and the string is then returned to the application:

```
SELECT PACK(CCSID 1208, 'Alina', DATE'1977-08-01', DOUBLE(0.5))
FROM SYSIBM.SYSDUMMYU;
```

The statement returns a VARBINARY string with the following content (The result is displayed in hexadecimal format and includes space separators for readability. The actual result is not in hexadecimal format and does not include any space separators):

```
00 0003 01C4 0180 01E0 04B80005416C696E61 19770801 3FE0000000000000
```

The character string 'Alina' is in UTF-8 (CCSID 1208) format regardless of the string's original encoding because of the CCSID 1208 specification in the PACK invocation.

The resulting string is VARBINARY(30). The length attribute of 30 is determined by the following elements:

- 1 (flag byte)
- +2 (size of number of items)
- +2*3 (2-byte data type times number of items)
- +2 (CCSID) + 2 (length) + 5 (VARCHAR(5) data length)
- +4 (DATE data length)
- +8 (DOUBLE length)

The actual length of the result is also 30.

Example 2: The following statement shows that when NULL values are packed into a binary string, they do not occupy any space in the encoded values portion of the result:

```
SELECT PACK(CCSID DEFAULT, '', CAST(NULL AS TIME),
           CAST('Bridget' AS VARCHAR(20) CCSID EBCDIC))
FROM SYSIBM.SYSDUMMYU;
```

The statement returns a VARBINARY string with the following content. (The result is displayed in hexadecimal format and includes space separators for readability. The actual result is not in hexadecimal format and does not include any space separators.)

```
00 0003 01C4 0185 01C4 04B80000 00250007C2D9C9C4C7C5E3
```

The character string '' (empty string) is packed in its original CCSID 1208 format, and 'Bridget' is packed in its original CCSID 37 format, because of the CCSID DEFAULT specification in the PACK invocation.

The resulting string is VARBINARY(40). The length attribute of 40 is determined by the following elements:

- 1 (flag byte)
- +2 (size of number of items)
- +2*3 (2-byte data type times number of items)
- +2 (CCSID) + 2 (length) + 0 (empty string data length)
- +3 (TIME data length)
- +2 (CCSID) + 2 (length) + 20 (VARCHAR(20) max length)

The actual length of the resulting string is 24, which is determined by the following elements

- 1 (flag byte)
- +2 (size of number of items)
- +2*3 (2-byte data type times number of items)
- +2 (CCSID) + 2 (length) + 0 (empty string data length)
- +0 (NULL)
- +2 (CCSID) + 2 (length) + 7 (VARCHAR(20) actual length)

Related reference

SQLTYPE and SQLLEN

The contents of the SQLTYPE and SQLLEN fields of the SQLDA depends on the SQL statement that is returning the value.

UNPACK row function

The UNPACK function returns a row of values that are derived from unpacking the input binary string. It is used to unpack a string that was encoded according to the PACK function.

POSITION scalar function

The POSITION function returns the position of the first occurrence of an argument within another argument, where the position is expressed in terms of the string units that are specified.

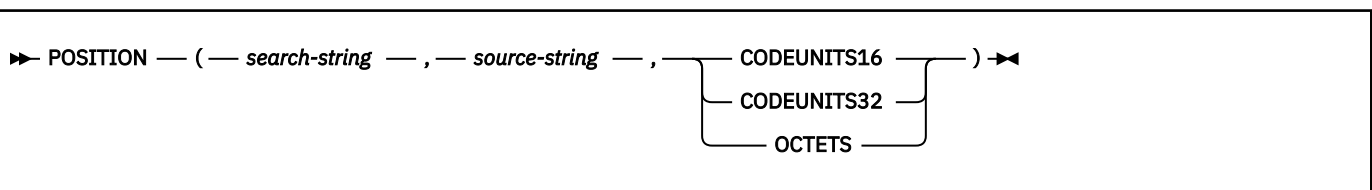

The schema is SYSIBM.

If *search-string* is not found and neither argument is null, the result is 0. If *search-string* is found, the result is a number from 1 to the actual length of *source-string*, expressed in the units that are explicitly specified.

search-string

An expression that specifies the string for which to search. *search-string* must return a value that is any built-in string data type with an actual length that is no greater than 4000 bytes.

The argument can also be a numeric data type. The numeric argument is implicitly cast to a VARCHAR data type.

The expression can be specified by any of the following items:

- A constant
- A special register
- A variable
- A scalar function whose arguments are any of the above (although nested function invocations cannot be used)
- An array element specification
- An expression that concatenates (using CONCAT or ||) any of the above
- A CAST specification whose arguments are any of the above
- A column name

These rules are similar to those that are described for *pattern-expression* for the LIKE predicate.

source-string

An expression that specifies the source string in which the search is to take place. *source-string* must return a value that is any built-in string data type.

The argument can also be a numeric data type. The numeric argument is implicitly cast to a VARCHAR data type.

The expression can be specified by any of the following items:

- A constant
- A special register
- A variable
- A scalar function whose arguments are any of the above (though nested function invocations cannot be used)
- A column name
- An array element specification
- A CAST specification whose arguments are any of the above
- An expression that concatenates (using CONCAT or ||) any of the above

CODEUNITS16, CODEUNITS32, or OCTETS

Specifies the string unit that is used to express the result. If *source-string* is a character string that is defined as bit data, CODEUNITS16, or CODEUNITS32 cannot be specified. If *source-string* is a graphic string, OCTETS cannot be specified.

CODEUNITS16

Specifies that the result is expressed in terms of 16-bit UTF-16 code units.

CODEUNITS32

Specifies that the result is expressed in terms of 32-bit UTF-32 code units.

OCTETS

Specifies that the result is expressed in terms of bytes.

For more information about CODEUNITS16, CODEUNITS32, and OCTETS, see [“String unit specifications” on page 106](#).

The first and second arguments must have compatible string types. For more information on compatibility, see “Conversion rules for operations that combine strings”.

If the search string and source string have different CCSID sets, then the *search-string* is converted to the CCSID set of the source string. If either CODEUNITS16 or CODEUNITS32 is specified, the function might be evaluated on a temporary copy of the data in Unicode.

The strings can contain mixed data. If OCTETS is specified:

- For ASCII data, if the search string or source string contains mixed data, the search string is found only if the same combination of single-byte and double-byte characters are found in the source string in exactly the same positions.
- For EBCDIC data, if the search string or source string contains mixed data, the search string is found only if any shift-in or shift-out characters are found in the source string in exactly the same positions, ignoring any redundant shift characters.
- For UTF-8 data, if the search string or source string contains mixed data, the search string is found only if the same combination of single-byte and multi-byte characters are found in the source string in exactly the same position.

The result of the function is a large integer. The POSITION function accepts mixed data strings.

The result can be null; if any argument is null, the result is the null value.

When the POSITION function is invoked with OCTETS, the function operates on a strict byte-count basis without regard to single-byte or double-byte characters.

If the CCSID of the search string is different than the CCSID of the source string, it is converted to the CCSID of the source string.

The value of the result is determined by applying these rules in the order in which they appear:

- If *search-string* has a length of zero, the result is 1.
- If *source-string* has a length of zero, the result is 0.
- If the value of *search-string* is equal to an identical length of substring of contiguous positions within the value of *source-string*, the result is the starting position of the first such substring within the source string value.
- Otherwise, the result is 0. This includes the case where *search-string* is longer than *source-string*.

Examples

Example 1:

Select the RECEIVED column, the SUBJECT column, and the starting position of the string 'GOOD BEER' within the NOTE_TEXT column for all rows in the IN_TRAY table that contain that string.

```
SELECT RECEIVED, SUBJECT, POSITION('GOOD BEER', NOTE_TEXT, OCTETS)
FROM IN_TRAY
WHERE POSITION('GOOD BEER', NOTE_TEXT, OCTETS) <> 0;
```

Example 2:

Find the position of the character 'ß' in the string 'Jürgen lives on Hegelstraße', and set the host variable *LOCATION* with the position, as measured in CODEUNITS32 units, within the string.

```
SET :LOCATION = POSITION('ß','Jürgen lives on Hegelstraße',CODEUNITS32);
```

The value of host variable *LOCATION* is set to 27.

Example 3:

Find the position of the character 'ß' in the string 'Jürgen lives on Hegelstraße', and set the host variable *LOCATION* with the position, as measured in OCTETS, within the string.

```
SET :LOCATION = POSITION('ß','Jürgen lives on Hegelstraße',OCTETS);
```

The value of host variable *LOCATION* is set to 28.

Related reference

[“LOCATE scalar function” on page 490](#)

The LOCATE function returns the position at which the first occurrence of an argument starts within another argument.

POSSTR or STRPOS scalar function

The POSSTR function returns the position of the first occurrence of an argument within another argument.

```
►► POSSTR( source-string , search-string ) ►►
```

The schema is SYSIBM.

If *search-string* is not found and neither argument is null, the result is 0. If *search-string* is found, the result is a number from 1 to the actual length of *source-string*.

source-string

An expression that specifies the source string in which the search is to take place. *source-string* must return a value that is a built-in character string data type, graphic string data type, or binary string data type.

The argument can also be a numeric data type. The numeric argument is implicitly cast to a VARCHAR data type.

search-string

An expression that specifies the string for which to search. *search-string* must return a value that is a built-in character string data type, graphic string data type, or binary string data type with an actual length that is no greater than 4000 bytes.

The argument can also be a numeric data type. The numeric argument is implicitly cast to a VARCHAR data type.

The first and second arguments must have compatible string types. For more information on compatibility, see [“Conversion rules for comparisons” on page 159](#).

If the *search-string* and *source-string* have different CCSID sets, then the *search-string* is converted to the CCSID set of the *source-string*.

Both *search-string* and *source-string* have zero or more contiguous positions. For character strings and binary strings, a position is a byte. For graphic strings, a position is a DBCS character. Graphic Unicode data is treated as UTF-16 data; a UTF-16 supplementary character takes two DBCS characters to represent and as such is counted as two DBCS characters.

The strings can contain mixed data.

- For ASCII data, if *search-string* or *source-string* contains mixed data, *search-string* is found only if the same combination of single-byte and double-byte characters are found in *source-string* in exactly the same positions.
- For EBCDIC data, if *search-string* or *source-string* contains mixed data, *search-string* is found only if any shift-in or shift-out characters are found in *source-string* in exactly the same positions, ignoring any redundant shift characters.
- For UTF-8 data, if *search-string* or *source-string* contains mixed data, *search-string* is found only if the same combination of single-byte and multi-byte characters are found in *source-string* in exactly the same position.
- If none of the above conditions are met, the result is 0.

The result of the function is a large integer. The value of the result is determined by applying these rules in the order in which they appear:

- If the length of *search-string* is zero, the result is 1.

- If the length of *source-string* is zero, the result is 0.
- If the value of *search-string* is equal to an identical length substring of contiguous positions from the value of *source-string*, the result is the starting position of the first such substring within the value of *source-string*.

The result can be null; if any argument is null, the result is the null value.

Notes

Syntax alternatives:

FL 506 STRPOS is a synonym for POSSTR.

POSSTR operates on a strict byte-count basis without regard to single-byte or double-byte characters. It is recommended that if either the *search-string* or *source-string* contains mixed data, POSITION should be used instead of POSSTR. The POSITION function operates on a character basis. In an EBCDIC encoding scheme, any shift-in and shift-out characters are not required to be in exactly the same position and their only significance is to indicate which characters are SBCS and which characters are DBCS.

Examples

Example: Select the RECEIVED column, the SUBJECT column, and the starting position of the string 'GOOD BEER' within the NOTE_TEXT column for all rows in the IN_TRAY table that contain that string.

```
SELECT RECEIVED, SUBJECT, POSSTR(NOTE_TEXT, 'GOOD BEER')
FROM IN_TRAY
WHERE POSSTR(NOTE_TEXT, 'GOOD BEER') <> 0;
```

Related reference

“LOCATE scalar function” on page 490

The LOCATE function returns the position at which the first occurrence of an argument starts within another argument.

“LOCATE_IN_STRING scalar function” on page 493

The LOCATE_IN_STRING function returns the position at which an argument starts within a specified string.

“POSITION scalar function” on page 529

The POSITION function returns the position of the first occurrence of an argument within another argument, where the position is expressed in terms of the string units that are specified.

POWER or POW scalar function

The POWER function returns the value of the first argument to the power of the second argument.

FL 506

```
POWER (numeric-expression-1 ,numeric-expression-2 )
```

POW

The schema is SYSIBM.

Each argument must be an expression that returns the value of any built-in numeric data type. If either argument includes a DECIMAL or REAL data type, but not a DECFLOAT data type, the arguments are converted to a double precision floating-point number for processing by the function. If either argument includes a DECFLOAT data type, the arguments are converted to DECFLOAT for processing by the function.

The result of the function depends on the data type of the arguments:

- If both arguments are SMALLINT or INTEGER, the result is INTEGER.
- If either argument is a DECFLOAT, the data type of the result is DECFLOAT(34).

If either argument is a DECFLOAT and one of the following statements is true, the result is NaN and an invalid operation condition:

- both arguments are zero
 - the second argument has a non-zero fractional part
 - the second argument has more than 9 digits
 - the second argument is Infinite
- Otherwise, the result is DOUBLE.

The result can be null; if any argument is null, the result is the null value.

Examples

Example 1

Assume that host variable *HPOWER* is INTEGER with a value of 3. The following statement returns the value 8.

```
SELECT POWER(2, :HPOWER)
FROM SYSIBM.SYSDUMMY1;
```

Example 2

The following statement returns the value 1.

```
SELECT POWER(0,0)
FROM SYSIBM.SYSDUMMY1;
```

QUANTIZE scalar function

The QUANTIZE function returns a DECFLOAT value that is equal in value (except for any rounding) and sign to the first argument and that has an exponent that is set to equal the exponent of the second argument.

►► QUANTIZE(*expression-1*, *expression-2*) ◄◄

The schema is SYSIBM.

The number of digits that is returned (16 or 34) is the same as the number of digits in *expression-1*.

expression-1

The argument must be an expression that returns a value of any built-in numeric data type. If the argument is not a DECFLOAT value, it is converted to DECFLOAT(34) for processing.

The argument can also be a character string or graphic string data type. The string input is implicitly cast to a numeric value of DECFLOAT(34).

expression-2

The argument must be an expression that returns a value of any built-in numeric data type. If the argument is not a DECFLOAT value, it is converted to DECFLOAT(34) for processing. *expression-2* is an expression that is used as an example pattern that will be used to rescale *expression-1*. The sign and coefficient of the second argument are ignored.

The argument can also be a character string or graphic string data type. The string input is implicitly cast to a numeric value of DECFLOAT(34).

If one argument (after conversion) is DECFLOAT(16) and the other is DECFLOAT(34), the DECFLOAT(16) argument is converted to DECFLOAT(34) before the function is processed.

The coefficient of the result is derived from that of *expression-1*. It is rounded, if necessary (if the exponent is being increased), multiplied by a power of ten (if the exponent is being decreased), or remains unchanged (if the exponent is already equal to that of *expression-2*).

For static SQL statements other than CREATE VIEW, the ROUNDING bind option or the native SQL procedure option determines the rounding mode.

For dynamic SQL statements (and static CREATE VIEW statements), the special register CURRENT DECFLOAT ROUNDING MODE determines the rounding mode.

Unlike other arithmetic operations on the DECFLOAT data type, if the length of the coefficient after the quantize operation is greater than the precision specified by *expression-2*, a warning occurs. This ensures that, unless there is an error condition, the exponent of the result of QUANTIZE is always equal to that of *expression-2*. Furthermore:

- If either argument is NaN, NaN is returned
- If either argument is sNaN, NaN is returned and an exception occurs
- If both arguments are infinity (positive or negative), infinity (positive or negative) is returned.
- If one argument is infinity (positive or negative) and the other argument is not infinity (positive or negative), NaN is returned and an exception occurs

The result of the function is a DECFLOAT(16) value if both arguments are DECFLOAT(16). Otherwise, the result of the function is a DECFLOAT(34) value.

The result can be null; if any argument is null, the result is the null value.

Examples: The following examples illustrate the value that is returned for the QUANTIZE function given the input DECFLOAT values:

```
QUANTIZE(2.17, DECFLOAT(0.001)) = 2.170
QUANTIZE(2.17, DECFLOAT(0.01)) = 2.17
QUANTIZE(2.17, DECFLOAT(0.1)) = 2.2
QUANTIZE(2.17, DECFLOAT('1E+0')) = 2
QUANTIZE(2.17, DECFLOAT('1E+1')) = 0E+1
QUANTIZE(2, DECFLOAT(INFINITY)) = NAN -- exception
QUANTIZE(-0.1, DECFLOAT(1)) = 0
QUANTIZE(0, DECFLOAT('1E+5')) = 0E+5
QUANTIZE(217, DECFLOAT('1E-1')) = 217.0
QUANTIZE(217, DECFLOAT('1E+0')) = 217
QUANTIZE(217, DECFLOAT('1E+1')) = 2.2E+2
QUANTIZE(217, DECFLOAT('1E+2')) = 2E+2
```

QUARTER scalar function

The QUARTER function returns an integer in the range 1–4 that represents the quarter of the year in which the date resides. For example, any dates in January, February, or March return the integer 1.

►► QUARTER(*expression*) ◄◄

The schema is SYSIBM.

The argument must be an expression that returns one of the following built-in data types: a date, a timestamp, a character string, or a graphic string. If *expression* is a character or graphic string data type, it must not be a CLOB or DBCLOB, and its value must be a valid string representation of a date or timestamp with an actual length of not greater than 255 bytes. For the valid formats of string representations of dates and timestamps, see [“String representations of datetime values” on page 120](#).

If *expression* is a timestamp with a time zone, or a valid string representation of a timestamp with a time zone, the result is determined from the UTC representation of the datetime value.

The result of the function is a large integer.

The result can be null; if the argument is null, the result is the null value.

Example 1: The following function returns 3 because August is in the third quarter of the year.

```
SELECT QUARTER('2008-08-25')
FROM SYSIBM.SYSDUMMY1
```

Example 2: Using sample table DSN8C10.PROJ, set the integer host variable *QUART* to the quarter of the year in which activity number 70 for project 'AD3111' occurred. Activity completion dates are recorded in column ACENDATE.

```
SELECT QUARTER(ACENDATE)
      INTO :QUART
      FROM DSN8C10.PROJ
      WHERE PROJNO = 'AD3111' AND ACTNO = 70;
```

QUART is set to 4.

Example 3: The following invocations of the QUARTER function returns the same result:

```
SELECT QUARTER('2003-01-02-20.10.05.123456'),
      QUARTER('2003-01-02-12.10.05.123456-08:00'),
      QUARTER('2003-01-03-05.10.05.123456+09:00')
      FROM SYSIBM.SYSDUMMY1;
```

For each invocation of the QUARTER function in this SELECT statement, the result is 1.

When the input argument contains a time zone, the result is determined from the UTC representation of the input value. The string representations of a timestamp with a time zone in the SELECT statement all have the same UTC representation: 2003-01-02-20.10.05.123456. The month portion of the UTC representation is 1 for January, which is in the first quarter.

RADIANS scalar function

The RADIANS function returns the number of radians for an argument that is expressed in degrees.

►► RADIANS(*numeric-expression*) ◄◄

The schema is SYSIBM.

The argument must be an expression that returns the value of any built-in numeric data type that is not DECFLOAT. If the argument is not a double precision floating-point number, it is converted to one for processing by the function.

The result of the function is a double precision floating-point number.

The result can be null; if the argument is null, the result is the null value.

Example: Assume that host variable *HDEG* is an INTEGER with a value of 180. The following statement returns a double precision floating-point number with an approximate value of 3.1415926536.

```
SELECT RADIANS(:HDEG)
      FROM SYSIBM.SYSDUMMY1;
```

RAISE_ERROR scalar function

The RAISE_ERROR function causes the statement that invokes the function to return an error with the specified SQLSTATE (along with SQLCODE -438) and error condition. The RAISE_ERROR function always returns the null value with an undefined data type.

►► RAISE_ERROR(*sqlstate* , *diagnostic-string*) ◄◄

The schema is SYSIBM.

sqlstate

An expression that returns a character string (CHAR or VARCHAR) of exactly 5 characters.

The argument can also be a numeric data type. The numeric argument is implicitly cast to a VARCHAR(5) data type.

The *sqlstate* value must follow these rules for application-defined SQLSTATES:

- Each character must be from the set of digits ('0' through '9') or non-accented upper case letters ('A' through 'Z').
- The SQLSTATE class (first two characters) cannot be '00', '01', or '02' because these are not error classes.
- If the SQLSTATE class (first two characters) starts with the character '0' through '6' or 'A' through 'H', the subclass (last three characters) must start with a letter in the range 'I' through 'Z'.
- If the SQLSTATE class (first two characters) starts with the character '7', '8', '9', or 'I' through 'Z', the subclass (last three characters) can be any of '0' through '9' or 'A' through 'Z'.

diagnostic-string

An expression that returns a character string with a data type of CHAR or VARCHAR and a length of up to 70 bytes. The string contains EBCDIC data that describes the error condition. If the string is longer than 70 bytes, it is truncated.

Since the data type of the result of RAISE_ERROR is undefined, it can only be used in a SET *host-variable* or SQL procedure language *assignment-statement*. To use this function in another context, such as alone in a select list, you must use a cast specification to give a data type to the null value that is returned. The RAISE_ERROR function is most useful with CASE expressions.

Example: For each employee in sample table DSN8C10.EMP, list the employee number and education level. List the education level as 'Post Graduate', 'Graduate' and 'Diploma' instead of the integer that it is stored as in the table. If an education level is greater than '20', raise an error ('70001') with a description.

```
SELECT EMPNO,  
       CASE WHEN EDLEVEL < 16 THEN 'Diploma'  
            WHEN EDLEVEL < 18 THEN 'Graduate'  
            WHEN EDLEVEL < 21 THEN 'Post Graduate'  
            ELSE RAISE_ERROR('70001',  
                           'EDUCLVL has a value greater than 20')  
       END  
FROM DSN8C10.EMP;
```

RANDOM or RAND scalar function

The RANDOM function returns a random floating-point value in the range 0–1. An argument can be specified as an optional seed value.

[FL 506](#)



The schema is SYSIBM.

numeric-expression

If *numeric-expression* is specified, it is used as the seed value. The argument must be an expression that returns a value of a built-in integer data type (SMALLINT or INTEGER). The value must be in the range 0–2,147,483,646.

The argument can also be a character string or graphic string data type. The string input is implicitly cast to a numeric value of DECFLOAT(34) and then assigned to an INTEGER value.

The result of the function is a double precision floating-point number.

The result can be null; if the argument is null, the result is the null value.

A specific seed value, other than zero, will produce the same sequence of random numbers for a specific instance of a RANDOM function in a query each time the query is executed. The seed value is used only for the first invocation of an instance of the RANDOM function within a statement. RANDOM(0) is processed the same as RANDOM().

Notes

Determinism:

RANDOM is a non-deterministic function.

Examples

Example 1

Assume that host variable *HRAND* is an INTEGER with a value of 100. The following statement returns a random floating-point number in the range 0–1, such as the approximate value .0121398:

```
SELECT RANDOM(:HRAND)
FROM SYSIBM.SYSDUMMY1;
```

Example

To generate values in a numeric interval other than 0 to 1, multiply the RAND function by the size of the interval that you want. For example, to get a random number in the range 0–10, such as the approximate value 5.8731398, multiply the function by 10:

```
SELECT (RANDOM(:HRAND) * 10)
FROM SYSIBM.SYSDUMMY1;
```

REAL scalar function

The REAL function returns a single-precision floating-point representation of either a number or a string representation of a number.

Numeric to Real:

```
►► REAL(numeric-expression) ◄◄
```

String to Real:

```
►► REAL(string-expression) ◄◄
```

The schema is SYSIBM.

Numeric to Real

numeric-expression

An expression that returns a value of any built-in numeric data type.

The result is the same number that would occur if the argument were assigned to a single precision floating-point column or variable. If the numeric value of the argument is not within the range of single precision floating-point, an error occurs.

String to Real

string-expression

An expression that returns a value of a character or graphic string (except a CLOB or DBCLOB) with a length attribute that is not greater than 255 bytes. The string must contain a valid string representation of a number.

The result is the same number that would result from `CAST(string-expression AS REAL)`. Leading and trailing blanks are eliminated and the resulting string must conform to the rules for forming an SQL floating-point, integer, or decimal constant.

The result of the function is a single precision floating-point number.

The result can be null; if the argument is null, the result is the null value.

Notes

Syntax alternatives:

To increase the portability of applications, use the CAST specification. For more information, see [“CAST specification” on page 267](#).

Examples

Example 1:

Using sample table DSN8C10.EMP, find the ratio of salary to commission for employees whose commission is not zero. The columns involved, SALARY and COMM, have decimal data types. To express the result in single precision floating-point, apply REAL to SALARY so that the division is carried out in floating-point (actually double precision) and then apply REAL to the complete expression so that the results are returned in single precision floating-point.

```
SELECT EMPNO, REAL (REAL (SALARY) / COMM)
FROM DSN8C10.EMP
WHERE COMM > 0;
```

REGEXP_COUNT scalar function

The REGEXP_COUNT scalar function returns a count of the number of times that a regular expression pattern is matched in a string.

FL 504

Passthrough-only expression: This function is passthrough-only and cannot run on Db2 for z/OS without acceleration. For information about invoking this function, see [Accelerating queries with passthrough-only expressions](#).

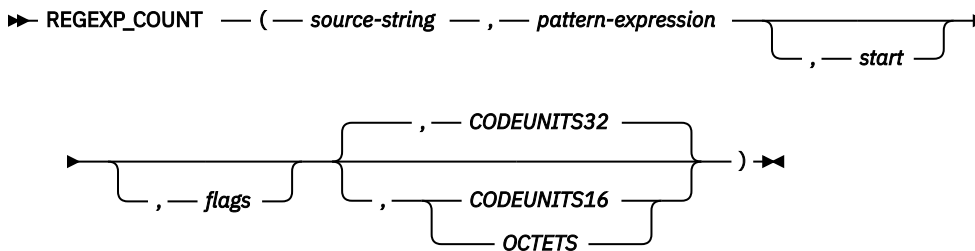

The schema is SYSIBM.

source-string

An expression that specifies the string in which the search is to take place. This expression must return a built-in character string, graphic string, numeric value, Boolean value, or datetime value. A numeric, Boolean, or datetime value is implicitly cast to VARCHAR before the function is evaluated. A character string cannot specify the FOR BIT DATA attribute.

pattern-expression

An expression that specifies the regular expression string that is the pattern for the search. This expression must return a built-in character string, graphic string, numeric value, Boolean value, or datetime value. A numeric, Boolean, or datetime value is implicitly cast to VARCHAR before the function is evaluated. A character string cannot specify the FOR BIT DATA attribute.

start

An expression that specifies the position within *source-string* at which the search is to start. The expression must return a built-in character string, graphic string, Boolean, or numeric value. If the value is not of type INTEGER, it is implicitly cast to INTEGER before the function is evaluated. The value of the integer must be greater than or equal to 1. If OCTETS is specified and the source string is graphic data, the value of the integer must be odd. The default start value is 1. See parameter description for CODEUNITS16, CODEUNITS32, or OCTETS for the string unit that applies to the start position.

flags

An expression that specifies flags that controls aspects of the pattern matching. The expression must return a built-in character string that does not specify the FOR BIT DATA attribute. The string can include one or more valid flag values and the combination of flag values must be valid. An empty string is the same as the value 'c'. The default flag value is 'c'.

Flag value	Description
c	Specifies that matching is case-sensitive. This flag is the default value if 'c' or 'i' is not specified. This value must not be specified with a value of 'i'.
i	Specifies that matching is case insensitive. This value must not be specified with a value of 'c'.
m	Specifies that the input data can contain more than one line. By default, the '^' in a pattern matches only the start of the input string; the '\$' in a pattern matches only the end of the input string. If this flag is set, "^" and "\$" also matches at the start and end of each line within the input string.
n	Specifies that the '\n' character in a pattern matches a line terminator in the input string. By default, the '\n' character in a pattern does not match a line terminator. A carriage-return and line-feed pair in the input string behaves as a single-line terminator and matches a single "\n" in a pattern.
s	Specifies that the '\n' character in a pattern matches a line terminator in the input string. This value is a synonym for the 'n' value.
x	Specifies that white space characters in a pattern are ignored, unless escaped.

CODEUNITS16, CODEUNITS32, or OCTETS

Specifies the string unit of the start value:

- CODEUNITS16 specifies that the start value is expressed in 16-bit UTF-16 code units.
- CODEUNITS32 specifies that the start value is expressed in 32-bit UTF-32 code units. This is the default.
- OCTETS specifies that the start value is expressed in bytes.

If the string unit is specified as CODEUNITS16 or OCTETS, and if the string unit of the source string is CODEUNITS32, an error is returned.

For more information, see [“String unit specifications”](#) on page 106.

The result of the function is an INTEGER that represents the number of occurrences of the pattern expression within the source string. If the pattern expression is not found and no argument is null, the result is 0.

If any argument of the REGEXP_COUNT function can be null, the result can be null. If any argument is null, the result is the null value.

Notes

- The regular expression processing is done by using the International Components for Unicode (ICU) regular expression interface.
- Considerations for non-Unicode databases:
 - A regular expression pattern supports only halfwidth control characters; use a character string data type for the pattern expression argument. A character string data type can be used for the pattern expression argument even when a graphic string data type is used for the source string argument.

- The source string argument must be a graphic string data type if the pattern expression argument is a graphic string data type.

For more information, see [Regular expression control characters](#).

Example

Count the number of times "Steven" or "Stephen" occurs in the string "Steven Jones and Stephen Smith are the best players".

```
SELECT REGEXP_COUNT(
  'Steven Jones and Stephen Smith are the best players', 'Ste(v|ph)en')
FROM sysibm.sysdummy1
```

The result is 2.

REGEXP_INSTR scalar function

The REGEXP_INSTR scalar function returns the starting or ending position of the matched substring, depending on the value of the **return_option** argument.

FL 504

Passthrough-only expression: This function is passthrough-only and cannot run on Db2 for z/OS without acceleration. For information about invoking this function, see [Accelerating queries with passthrough-only expressions](#).

➔ REGEXP_INSTR ((*source-string* , *pattern-expression*)

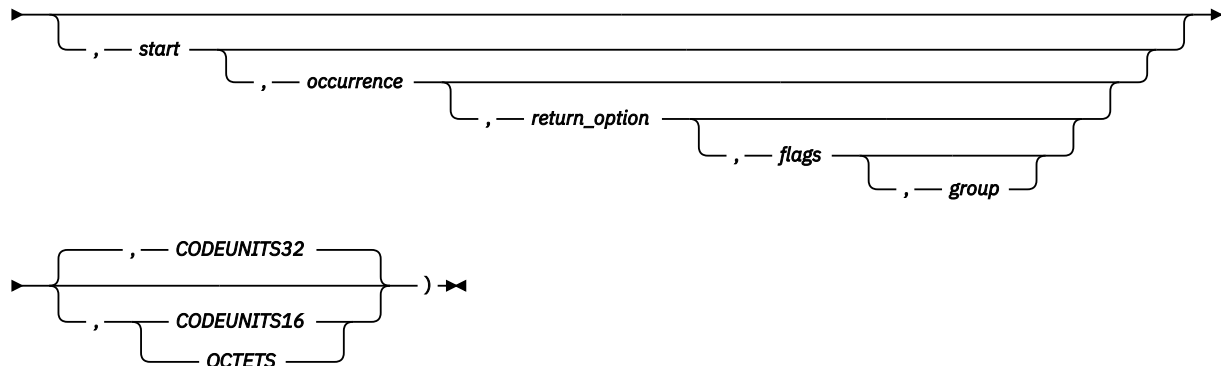

The schema is SYSIBM.

source-string

An expression that specifies the string in which the search is to take place. This expression must return a built-in character string, graphic string, numeric value, Boolean value, or datetime value. A numeric, Boolean, or datetime value is implicitly cast to VARCHAR before the function is evaluated. A character string cannot specify the FOR BIT DATA attribute.

pattern-expression

An expression that specifies the regular expression string that is the pattern for the search. This expression must return a built-in character string, graphic string, numeric value, Boolean value, or datetime value. A numeric, Boolean, or datetime value is implicitly cast to VARCHAR before the function is evaluated. A character string cannot specify the FOR BIT DATA attribute.

start

An expression that specifies the position within *source-string* at which the search is to start. The expression must return a built-in character string, graphic string, Boolean, or numeric value. If the value is not of type INTEGER, it is implicitly cast to INTEGER before the function is evaluated. The value of the integer must be greater than or equal to 1. If OCTETS is specified and the source string is graphic data, the value of the integer must be odd. The default start value is 1. See parameter

description for CODEUNITS16, CODEUNITS32, or OCTETS for the string unit that applies to the start position.

occurrence

An expression that specifies which occurrence of the pattern expression within the source string to search for. The expression must return a built-in character string, graphic string, Boolean, or numeric value. If the value is not of type INTEGER, it is implicitly cast to INTEGER before the function is evaluated. This value must be greater than or equal 1. The default occurrence value is 1, which indicates that only the first occurrence of the pattern expression is considered.

return-option

An expression that specifies what is returned relative to the occurrence. The expression must return a built-in character string, graphic string, Boolean, or numeric value. If the value is not of type INTEGER, it is implicitly cast to INTEGER before the function is evaluated. This value must be 0 or 1:

- A value of 0 returns the position of the first string unit of the occurrence.
- A value of 1 returns the position of the string unit that follows the occurrence.

The default return option value is 0.

flags

An expression that specifies flags that controls aspects of the pattern matching. The expression must return a built-in character string that does not specify the FOR BIT DATA attribute. The string can include one or more valid flag values and the combination of flag values must be valid. An empty string is the same as the value 'c'. The default flag value is 'c'.

Flag value	Description
c	Specifies that matching is case-sensitive. This flag is the default value if 'c' or 'i' is not specified. This value must not be specified with a value of 'i'.
i	Specifies that matching is case insensitive. This value must not be specified with a value of 'c'.
m	Specifies that the input data can contain more than one line. By default, the '^' in a pattern matches only the start of the input string; the '\$' in a pattern matches only the end of the input string. If this flag is set, "^" and "\$" also matches at the start and end of each line within the input string.
n	Specifies that the '\n' character in a pattern matches a line terminator in the input string. By default, the '\n' character in a pattern does not match a line terminator. A carriage-return and line-feed pair in the input string behaves as a single-line terminator and matches a single "\n" in a pattern.
s	Specifies that the '\n' character in a pattern matches a line terminator in the input string. This value is a synonym for the 'n' value.
x	Specifies that white space characters in a pattern are ignored, unless escaped.

group

An expression that specifies which capture group of the pattern expression is used to determine the position within source string to return. The expression must return a built-in character string, graphic string, Boolean, or numeric value. If the value is not of type INTEGER, it is implicitly cast to INTEGER before the function is evaluated. This value must be greater than or equal to 0 and must not be greater than the number of capture groups in the pattern expression. The default group value is 0, which indicates that the position is based on the string that matches the entire pattern.

CODEUNITS16, CODEUNITS32, or OCTETS

Specifies the string unit of both the start value and the result:

- CODEUNITS16 specifies that the start value and result are expressed in 16-bit UTF-16 code units.

- CODEUNITS32 specifies that the start value and result are expressed in 32-bit UTF-32 code units. This is the default.
- OCTETS specifies that the start value and result are expressed in bytes.

If the string unit is specified as CODEUNITS16 or OCTETS, and the string unit of the source string is CODEUNITS32, an error is returned.

For more information, see [“String unit specifications” on page 106](#).

The result of the function is a large integer. If the pattern expression is found, the result is a number from 1 to n, where n is the actual length of the source string plus 1. The result value represents the position expressed in the string units used to process the function. If the pattern expression is not found and no argument is null, the result is 0.

If any argument of the REGEXP_INSTR function can be null, the result can be null. If any argument is null, the result is the null value.

Notes

- The regular expression processing is done by using the International Components for Unicode (ICU) regular expression interface.
- Considerations for non-Unicode databases:
 - A regular expression pattern supports only halfwidth control characters; use a character string data type for the pattern expression argument. A character string data type can be used for the pattern expression argument even when a graphic string data type is used for the source string argument.
 - The source string argument must be a graphic string data type if the pattern expression argument is a graphic string data type.

For more information, see [Regular expression control characters](#).

Examples

Example 1:

Find the first occurrence of a 'o' that has a character that is preceding it.

```
SELECT REGEXP_INSTR('hello to you', '.o',1,1)
FROM sysibm.sysdummy1
```

The result is 4, which is the position of the second 'l' character.

Example 2:

Find the second occurrence of a 'o' that has a character that is preceding it.

```
SELECT REGEXP_INSTR('hello to you', '.o',1,2)
FROM sysibm.sysdummy1
```

The result is 7, which is the position of the character 't'.

Example 3:

Find the position after the third occurrence of the first capture group of the regular expression '(o)!' using case insensitive matching.

```
SELECT REGEXP_INSTR('hello TO you', '(o).!', 1,3,1,'i',1)
FROM sysibm.sysdummy1
```

The result is 12, which is the position of the character 'u' at the end of the string.

REGEXP_LIKE scalar function

The REGEXP_LIKE scalar function returns an INTEGER value of 0 or 1 indicating if the regular expression pattern is found in a string.

[FL 504](#)

Passthrough-only expression: This function is passthrough-only and cannot run on Db2 for z/OS without acceleration. For information about invoking this function, see [Accelerating queries with passthrough-only expressions](#).

Db2 for z/OS casts the result of this function to an INTEGER (1 = 'true', 0 = 'false'). Db2 for z/OS currently does not support Boolean functions or data types.

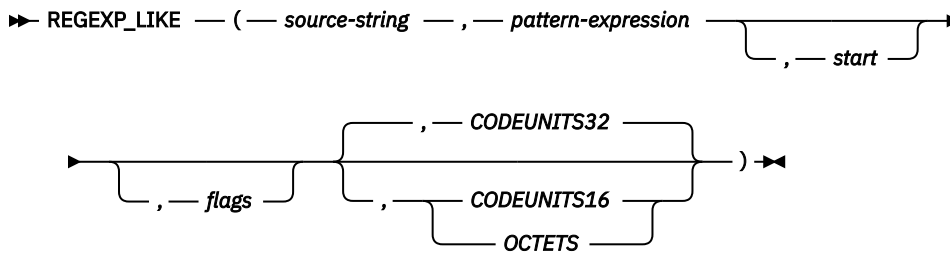

The schema is SYSIBM.

source-string

An expression that specifies the string in which the search is to take place. This expression must return a built-in character string, graphic string, numeric value, Boolean value, or datetime value. A numeric, Boolean, or datetime value is implicitly cast to VARCHAR before the function is evaluated. A character string cannot specify the FOR BIT DATA attribute.

pattern-expression

An expression that specifies the regular expression string that is the pattern for the search. This expression must return a built-in character string, graphic string, numeric value, Boolean value, or datetime value. A numeric, Boolean, or datetime value is implicitly cast to VARCHAR before the function is evaluated. A character string cannot specify the FOR BIT DATA attribute.

start

An expression that specifies the position within *source-string* at which the search is to start. The expression must return a built-in character string, graphic string, Boolean, or numeric value. If the value is not of type INTEGER, it is implicitly cast to INTEGER before the function is evaluated. The value of the integer must be greater than or equal to 1. If OCTETS is specified and the source string is graphic data, the value of the integer must be odd. The default start value is 1. See parameter description for CODEUNITS16, CODEUNITS32, or OCTETS for the string unit that applies to the start position.

flags

An expression that specifies flags that controls aspects of the pattern matching. The expression must return a built-in character string that does not specify the FOR BIT DATA attribute. The string can include one or more valid flag values and the combination of flag values must be valid. An empty string is the same as the value 'c'. The default flag value is 'c'.

Flag value	Description
c	Specifies that matching is case-sensitive. This flag is the default value if 'c' or 'i' is not specified. This value must not be specified with a value of 'i'.
i	Specifies that matching is case insensitive. This value must not be specified with a value of 'c'.
m	Specifies that the input data can contain more than one line. By default, the '^' in a pattern matches only the start of the input string; the '\$' in a pattern matches only the end of the input string. If this flag is set, "^" and "\$" also matches at the start and end of each line within the input string.

Flag value	Description
n	Specifies that the '.' character in a pattern matches a line terminator in the input string. By default, the '.' character in a pattern does not match a line terminator. A carriage-return and line-feed pair in the input string behaves as a single-line terminator and matches a single "." in a pattern.
s	Specifies that the '.' character in a pattern matches a line terminator in the input string. This value is a synonym for the 'n' value.
x	Specifies that white space characters in a pattern are ignored, unless escaped.

CODEUNITS16, CODEUNITS32, or OCTETS

Specifies the string unit of the start value:

- CODEUNITS16 specifies that the start value is expressed in 16-bit UTF-16 code units.
- CODEUNITS32 specifies that the start value is expressed in 32-bit UTF-32 code units. This is the default.
- OCTETS specifies that the start value is expressed in bytes.

If the string unit is specified as CODEUNITS16 or OCTETS, and if the string unit of the source string is CODEUNITS32, an error is returned.

For more information, see [“String unit specifications” on page 106](#).

The result of the function is an INTEGER value of 0 or 1. If the pattern expression is found, the result is true. If the pattern expression is not found, the result is false. If the value of any of the arguments is null, the result is unknown.

Notes

- The regular expression processing is done by using the International Components for Unicode (ICU) regular expression interface.
- Considerations for non-Unicode databases:
 - A regular expression pattern supports only halfwidth control characters; use a character string data type for the pattern expression argument. A character string data type can be used for the pattern expression argument even when a graphic string data type is used for the source string argument.
 - The source string argument must be a graphic string data type if the pattern expression argument is a graphic string data type.
 - The source string and replacement string arguments must both be character string data types or both be graphic string data types.

For more information, see [Regular expression control characters](#).

Examples

Example 1:

Select the employee number where the last name is spelled LUCCHESSI, LUCHESSI, or LUCHESEI from the EMPLOYEE table without considering upper or lower case letters.

```
SELECT EMPNO FROM EMPLOYEE
WHERE REGEXP_LIKE(LASTNAME, 'luc+?hes+?i', 'i') = 1
```

The result is 1 row with EMPNO value '000110'.

Example 2:

Select any invalid product identifier values from the PRODUCT table. The expected format is 'nnn-nnn-nn' where 'n' is a digit 0–9.

```
SELECT PID FROM PRODUCT
WHERE NOT REGEXP_LIKE(pid, '[0-9]{3}-[0-9]{3}-[0-9]{2}') = 1
```

The result is 0 rows because all the product identifiers match the pattern.

REGEXP_REPLACE scalar function

The REGEXP_REPLACE scalar function returns a modified version of the source string where occurrences of the regular expression pattern found in the source string are replaced with the specified replacement string.

FL 504

Passthrough-only expression: This function is passthrough-only and cannot run on Db2 for z/OS without acceleration. For information about invoking this function, see [Accelerating queries with passthrough-only expressions](#).

►► REGEXP_REPLACE (— *source-string* — , — *pattern-expression* — ►

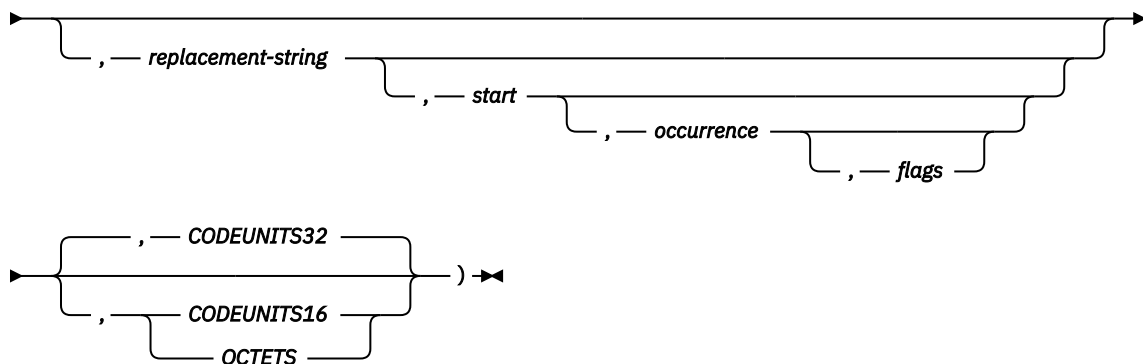

The schema is SYSIBM.

source-string

An expression that specifies the string in which the search is to take place. This expression must return a built-in character string, graphic string, numeric value, Boolean value, or datetime value. A numeric, Boolean, or datetime value is implicitly cast to VARCHAR before the function is evaluated. A character string cannot specify the FOR BIT DATA attribute.

pattern-expression

An expression that specifies the regular expression string that is the pattern for the search. This expression must return a built-in character string, graphic string, numeric value, Boolean value, or datetime value. A numeric, Boolean, or datetime value is implicitly cast to VARCHAR before the function is evaluated. A character string cannot specify the FOR BIT DATA attribute.

replacement-string

An expression that specifies the replacement string for matching substrings. The expression must return a value that is a built-in character string, graphic string, numeric value, Boolean value, or datetime value. A numeric, Boolean, or datetime value is implicitly cast to VARCHAR before the function is evaluated. A character string cannot specify the FOR BIT DATA attribute. The default replacement string is the empty string.

The content of the replacement string can include references to capture group text from the search to use in the replacement text. These references are of the form '\$n' or '\n', where n is the number of the capture group and 0 represents the entire string that matches the pattern. The value for n must be in the range 0-9 and not greater than the number of capture groups in the pattern. For example, either '\$2' or '\2' can be used to refer to the content found in the source string for the second capture group that is specified in the pattern expression. If the pattern expression must include a literal reference to a '\$' or '\' character, that character must be preceded with an '/' character as an escape character ('\\$\$' or '\\').

start

An expression that specifies the position within *source-string* at which the search is to start. The expression must return a built-in character string, graphic string, Boolean, or numeric value. If the value is not of type INTEGER, it is implicitly cast to INTEGER before the function is evaluated. The value of the integer must be greater than or equal to 1. If OCTETS is specified and the source string is graphic data, the value of the integer must be odd. The default start value is 1. See parameter description for CODEUNITS16, CODEUNITS32, or OCTETS for the string unit that applies to the start position.

occurrence

An expression that specifies which occurrence of the pattern expression within the source string is to be searched for and replaced. The expression must return a built-in character string, graphic string, Boolean, or numeric value. If the value is not of type INTEGER, it is implicitly cast to INTEGER before the function is evaluated. The occurrence value must be greater than or equal to 0. The default occurrence value is 0, which indicates that all occurrences of the pattern expression in the source string are replaced.

flags

An expression that specifies flags that controls aspects of the pattern matching. The expression must return a built-in character string that does not specify the FOR BIT DATA attribute. The string can include one or more valid flag values and the combination of flag values must be valid. An empty string is the same as the value 'c'. The default flag value is 'c'.

<i>Table 84. Supported flag values</i>	
Flag value	Description
c	Specifies that matching is case-sensitive. This flag is the default value if 'c' or 'i' is not specified. This value must not be specified with a value of 'i'.
i	Specifies that matching is case insensitive. This value must not be specified with a value of 'c'.
m	Specifies that the input data can contain more than one line. By default, the '^' in a pattern matches only the start of the input string; the '\$' in a pattern matches only the end of the input string. If this flag is set, "^" and "\$" also matches at the start and end of each line within the input string.
n	Specifies that the '\n' character in a pattern matches a line terminator in the input string. By default, the '\n' character in a pattern does not match a line terminator. A carriage-return and line-feed pair in the input string behaves as a single-line terminator and matches a single "\n" in a pattern.
s	Specifies that the '\n' character in a pattern matches a line terminator in the input string. This value is a synonym for the 'n' value.
x	Specifies that white space characters in a pattern are ignored, unless escaped.

CODEUNITS16, CODEUNITS32, or OCTETS

Specifies the string unit of the start value:

- CODEUNITS16 specifies that the start value is expressed in 16-bit UTF-16 code units.
- CODEUNITS32 specifies that the start value is expressed in 32-bit UTF-32 code units. This is the default.
- OCTETS specifies that the start value is expressed in bytes.

If the string unit is specified as CODEUNITS16 or OCTETS, and if the string unit of the source string is CODEUNITS32, an error is returned.

For more information, see [“String unit specifications” on page 106](#).

The result of the function is a string. If there are no occurrences of the pattern to be replaced and no argument is null, the original string is returned. The data type of the string is the same data type as the source string, except for CHAR, which becomes VARCHAR, and VARGRAPHIC, which becomes GRAPHIC.

The length attribute of the result data type is determined based on the length attributes of the source string and the replacement string by using the following calculation:

$$\text{MIN}(\text{MaxTypeLen}, \text{LAS} + (\text{LAS} + 1) * \text{LAR})$$

where *MaxTypeLen* represents the maximum length attribute for the data type of the result, *LAS* represents the length attribute for the data type of the source string, and *LAR* represents the length attribute for the data type of the replacement string. If the replacement string is not specified, the value for *LAR* is 0. If the actual length of the result string exceeds the maximum for the return data type, an error is returned.

If the replacement string is specified, the result buffer length is 32672 bytes. If the replacement string is not specified, the result buffer length is the same as the length of the source string except for the following data types:

Data Type	Length (in bytes)
numerical	42
date	10
time	8
timestamp	32

If any argument of the REGEXP_REPLACE function can be null, the result can be null. If any argument is null, the result is the null value.

Notes

- The regular expression processing is done by using the International Components for Unicode (ICU) regular expression interface.
- Considerations for non-Unicode databases:
 - A regular expression pattern supports only halfwidth control characters; use a character string data type for the pattern expression argument. A character string data type can be used for the pattern expression argument even when a graphic string data type is used for the source string argument.
 - The source string argument must be a graphic string data type if the pattern expression argument is a graphic string data type.
 - The source string and replacement string arguments must both be character string data types or both be graphic string data types.

For more information, see [Regular expression control characters](#).

Example

Replace the second occurrence of the pattern 'R.d' with 'Orange' using a case sensitive search.

```
SELECT REGEXP_REPLACE(
  'Red Yellow RED Blue Red Green Blue', 'R.d', 'Orange', 1, 2, 'c')
FROM sysibm.sysdummy1
```

The result is 'Red Yellow RED Blue Orange Green Blue'.

REGEXP_SUBSTR scalar function

The REGEXP_SUBSTR scalar function returns one occurrence of a substring of a string that matches the regular expression pattern.

FL 504

Passthrough-only expression: This function is passthrough-only and cannot run on Db2 for z/OS without acceleration. For information about invoking this function, see [Accelerating queries with passthrough-only expressions](#).

►► REGEXP_SUBSTR (— *source-string* — , — *pattern-expression* — ►►

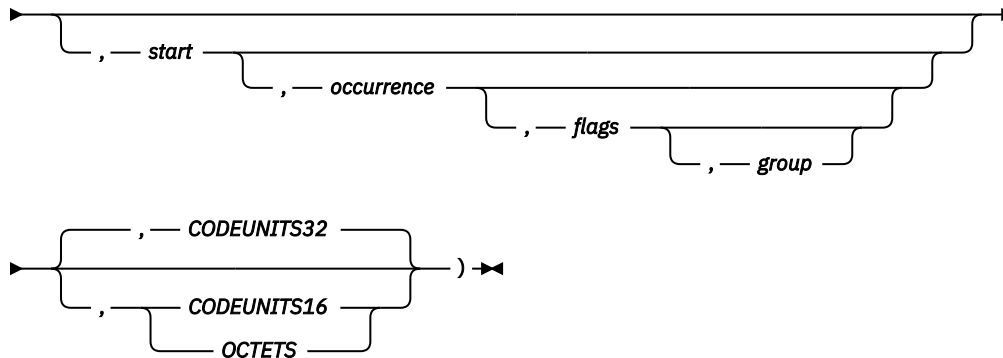

The schema is SYSIBM.

source-string

An expression that specifies the string in which the search is to take place. This expression must return a built-in character string, graphic string, numeric value, Boolean value, or datetime value. A numeric, Boolean, or datetime value is implicitly cast to VARCHAR before the function is evaluated. A character string cannot specify the FOR BIT DATA attribute.

pattern-expression

An expression that specifies the regular expression string that is the pattern for the search. This expression must return a built-in character string, graphic string, numeric value, Boolean value, or datetime value. A numeric, Boolean, or datetime value is implicitly cast to VARCHAR before the function is evaluated. A character string cannot specify the FOR BIT DATA attribute.

start

An expression that specifies the position within *source-string* at which the search is to start. The expression must return a built-in character string, graphic string, Boolean, or numeric value. If the value is not of type INTEGER, it is implicitly cast to INTEGER before the function is evaluated. The value of the integer must be greater than or equal to 1. If OCTETS is specified and the source string is graphic data, the value of the integer must be odd. The default start value is 1. See parameter description for CODEUNITS16, CODEUNITS32, or OCTETS for the string unit that applies to the start position.

occurrence

An expression that specifies which occurrence of the pattern expression within *source-string* to search for. The expression must return a built-in character string, graphic string, Boolean, or numeric value. If the value is not of type INTEGER, it is implicitly cast to INTEGER before the function is evaluated. The occurrence value must be greater than or equal 1. The default occurrence value is 1, which indicates that only the first occurrence of the pattern expression is considered.

flags

An expression that specifies flags that controls aspects of the pattern matching. The expression must return a built-in character string that does not specify the FOR BIT DATA attribute. The string can include one or more valid flag values and the combination of flag values must be valid. An empty string is the same as the value 'c'. The default flag value is 'c'.

Flag value	Description
c	Specifies that matching is case-sensitive. This flag is the default value if 'c' or 'i' is not specified. This value must not be specified with a value of 'i'.
i	Specifies that matching is case insensitive. This value must not be specified with a value of 'c'.
m	Specifies that the input data can contain more than one line. By default, the '^' in a pattern matches only the start of the input string; the '\$' in a pattern matches only the end of the input string. If this flag is set, "^" and "\$" also matches at the start and end of each line within the input string.
n	Specifies that the '\n' character in a pattern matches a line terminator in the input string. By default, the '\n' character in a pattern does not match a line terminator. A carriage-return and line-feed pair in the input string behaves as a single-line terminator and matches a single "\n" in a pattern.
s	Specifies that the '\n' character in a pattern matches a line terminator in the input string. This value is a synonym for the 'n' value.
x	Specifies that white space characters in a pattern are ignored, unless escaped.

group

An expression that specifies which capture group of the pattern expression within source string to return. The expression must return a built-in character, binary, or graphic string, or a Boolean value. If the value is not of type INTEGER, it is implicitly cast to INTEGER before the function is evaluated. The group value must be greater than or equal to 0 and must not be greater than the number of capture groups in the pattern expression. The default group value is 0, which indicates that the string that matches the entire pattern is to be returned.

CODEUNITS16, CODEUNITS32, or OCTETS

Specifies the string unit of the start value:

- CODEUNITS16 specifies that the start value is expressed in 16-bit UTF-16 code units.
- CODEUNITS32 specifies that the start value is expressed in 32-bit UTF-32 code units. This is the default.
- OCTETS specifies that the start value is expressed in bytes.

If the string unit is specified as CODEUNITS16 or OCTETS, and if the string unit of the source string is CODEUNITS32, an error is returned.

For more information, see [“String unit specifications”](#) on page 106.

The result of the function is a string. The data type of the string is the same data type as the source string, except for CHAR, which becomes VARCHAR; and GRAPHIC, which becomes and VARGRAPHIC. The length attribute of the result data type is same as the length attribute of the source string. The actual length of the result is the length of the occurrence in the string that matches the pattern expression. If the pattern expression is not found, the result is the null value.

The result buffer length is the same as the length of the source string except for the following data types:

Data Type	Length (in bytes)
numerical	42
date	10
time	8

Table 87. Data types with different result buffer lengths (continued)

Data Type	Length (in bytes)
timestamp	32

The result of the REGEXP_SUBSTR function can be null. If any argument is null, the result is the null value.

Notes

- The regular expression processing is done by using the International Components for Unicode (ICU) regular expression interface.
- Considerations for non-Unicode databases:
 - A regular expression pattern supports only halfwidth control characters; use a character string data type for the pattern expression argument. A character string data type can be used for the pattern expression argument even when a graphic string data type is used for the source string argument.
 - The source string argument must be a graphic string data type if the pattern expression argument is a graphic string data type.

For more information, see [Regular expression control characters](#).

Examples

Example 1:

Return the string which matches any character preceding a 'o'.

```
SELECT REGEXP_SUBSTR('hello to you', '.o',1,1)
FROM sysibm.sysdummy1
```

The result is 'lo'.

Example 2:

Return the third string occurrence which matches any character preceding a 'o'.

```
SELECT REGEXP_SUBSTR('hello to you', '.o',1,3)
FROM sysibm.sysdummy1
```

The result is 'yo'.

REPEAT scalar function

The REPEAT function returns a character string that is composed of an argument that is repeated a specified number of times.

► REPEAT(*expression*, *integer*) ◄

The schema is SYSIBM.

expression

An expression that specifies the string to be repeated. The expression must return a value that is a built-in character string, graphic string, or binary string data type that is not a LOB.

The argument can also be a numeric data type. The numeric argument is implicitly cast to a VARCHAR data type.

The actual length of the string must be greater or equal to 1 and less than or equal to 32704 bytes.

integer

integer must be a positive large integer value that specifies the number of times to repeat the string.

The argument can also be a character string or graphic string data type. The string input is implicitly cast to a numeric value of DECFLOAT(34) which is then assigned to an INTEGER value.

The result can be null; if any argument is null, the result is the null value.

The encoding scheme of the result is the same as *expression*. The data type of the result of the function depends on the data type of *expression*:

- VARBINARY if *expression* is a binary string
- VARCHAR if *expression* is a character string
- VARGRAPHIC if *expression* is graphic string

The CCSID of the result is the same as the CCSID of *expression*.

If *integer* is a constant, the length attribute of the result is the length attribute of *expression* times *integer*. Otherwise, the length attribute depends on the data type of the result:

- 4000 for VARBINARY and VARCHAR
- 2000 for VARGRAPHIC

The actual length of the result is the actual length of *expression* times *integer*. If the actual length of the result string exceeds the maximum for the return type, an error occurs.

Example 1: Repeat 'abc' two times to create 'abcabc'.

```
SELECT REPEAT('abc',2)
FROM SYSIBM.SYSDUMMY1;
```

Example 2: List the phrase 'REPEAT THIS' five times. Use the CHAR function to limit the output to 60 bytes.

```
SELECT CHAR(REPEAT('REPEAT THIS',5), 60)
FROM SYSIBM.SYSDUMMY1;
```

This example results in 'REPEAT THISREPEAT THISREPEAT THISREPEAT THISREPEAT THIS '.

Example 3: For the following query, the LENGTH function returns a value of 0 because the result of repeating a string zero times is an empty string, which is a zero-length string.

```
SELECT LENGTH(REPEAT('REPEAT THIS',0))
FROM SYSIBM.SYSDUMMY1;
```

Example 4: For the following query, the LENGTH function returns a value of 0 because the result of repeating an empty string any number of times is an empty string, which is a zero-length string.

```
SELECT LENGTH(REPEAT('', 5))
FROM SYSIBM.SYSDUMMY1;
```

REPLACE scalar function

The REPLACE function replaces all occurrences of *search-string* in *source-string* with *replace-string*. If *search-string* is not found in *source-string*, *source-string* is returned unchanged.

```
►► REPLACE ( ( — source-string — , — search-string — ) —►►
              , — replace-string — )
```

The schema is SYSIBM.

source-string

An expression that specifies the source string. The expression must return a value that is a built-in character string, graphic string, or binary string data type that is not a LOB and it cannot be an empty string.

The argument can also be a numeric data type. The numeric argument is implicitly cast to a VARCHAR data type.

The actual length of *source-string* must be 32764 bytes or less for character and binary strings or 16382 or less for graphic strings.

search-string

An expression that specifies the string to be removed from the source string. The expression must return a value that is a built-in character string, graphic string, or binary string data type that is not a LOB; the value cannot be an empty string.

The argument can also be a numeric data type. The numeric argument is implicitly cast to a VARCHAR data type.

The actual length of *search-string* must be 4000 bytes or less for character and binary strings or 2000 or less for graphic strings, unless the CCSID of *search-string* is Unicode DBCS. If the CCSID is Unicode DBCS, the actual length must be 16382 or less.

replace-string

An expression that specifies the replacement string. The expression must return a value that is a built-in character string, graphic string, or binary string data type that is not a LOB.

The argument can also be a numeric data type. The numeric argument is implicitly cast to a VARCHAR data type.

The actual length of *replace-string* must be 32764 bytes or less for character and binary strings or 16382 or less for graphic strings.

If *replace-string* is not specified or is an empty string, nothing replaces the string that is removed from the source string.

All three arguments must have compatible data types. If the expressions have different CCSID sets, then the expressions are converted to the CCSID set of *source-string*.

The data type of the result of the function depends on the data type of *source-string*, *search-string*, and *replace-string*:

- VARCHAR if *source-string* is a character string. The encoding scheme of the result is the same as *source-string*. The CCSID of the result depends on the arguments:
 - If *source-string*, *search-string*, or *replace-string* is bit data, the result is bit data.
 - If *source-string*, *search-string*, and *replace-string* are all SBCS Unicode data, the CCSID of the result is the CCSID for SBCS Unicode data.
 - If *source-string* is SBCS Unicode data, and *search-string* or *replace-string* is not SBCS Unicode data, the CCSID of the result is the mixed CCSID for Unicode data.
 - Otherwise, the CCSID of the result is the mixed CCSID that corresponds to the CCSID of *source-string*. However, if the input is EBCDIC or ASCII and there is no corresponding system CCSID for mixed, the CCSID of the result is the CCSID of *source-string*.
- VARGRAPHIC if *source-string* is a graphic. The encoding scheme of the result is the same as *source-string*. The CCSID of the result is the same as the CCSID of *source-string*.
- VARBINARY if *source-string*, *search-string*, and *replace-string* are binary strings.

The length attribute of the result depends on the arguments:

- If the length attribute of *replace-string* is less than or equal to the length attribute of *search-string*, the length attribute of the result is the length attribute of *source-string*.
- If the length attribute of *replace-string* is greater than the length attribute of *search-string*, the length attribute of the result is determined as follows depending on the data type of the result:
 - For VARCHAR or VARBINARY:
 - If $L1 \leq 4000$, the length attribute of the result is $\text{MIN}(4000, (L3 * (L1 / L2)) + \text{MOD}(L1, L2))$

- Otherwise, the length attribute of the result is $\text{MIN}(32764, (L3 * (L1/L2)) + \text{MOD}(L1, L2))$
- For VARGRAPHIC:
 - If $L1 \leq 2000$, the length attribute of the result is $\text{MIN}(2000, (L3 * (L1/L2)) + \text{MOD}(L1, L2))$
 - Otherwise, the length attribute of the result is $\text{MIN}(16382, (L3 * (L1/L2)) + \text{MOD}(L1, L2))$

where:

L1 is the length attribute of *source-string*

L2 is the length attribute of *search-string* if the search string is a string constant. Otherwise, *L2* is 1.

L3 is the length attribute of *replace-string*

If the result is a character string or binary string, the length attribute of the result must not exceed 32764. If the result is a graphic string, the length attribute of the result must not exceed 16382.

The actual length of the result is the actual length of *source-string* plus the number of occurrences of *search-string* that exist in *source-string* multiplied by the actual length of *replace-string* minus the actual length of *search-string*. If the actual length of the result string exceeds the maximum for the return data type, an error occurs.

The result can be null; if any argument is null, the result is the null value.

Examples

Example 1

Replace all occurrences of the character 'N' in the string 'DINING' with 'VID'. Use the CHAR function to limit the output to 10 bytes.

```
SELECT CHAR(REPLACE('DINING', 'N', 'VID'), 10)
FROM SYSIBM.SYSDUMMY1;
```

The result is the string 'DIVIDIVIDG'.

Example 2

Replace string 'ABC' in the string 'ABCXYZ' with nothing, which is the same as removing 'ABC' from the string.

```
SELECT REPLACE('ABCXYZ', 'ABC', '')
FROM SYSIBM.SYSDUMMY1;
```

The result is the string 'XYZ'.

Example 3

Replace string 'ABC' in the string 'ABCCABCC' with 'AB'. This example illustrates that the result can still contain the string that is to be replaced (in this case, 'ABC') because all occurrences of the string to be replaced are identified prior to any replacement.

```
SELECT REPLACE('ABCCABCC', 'ABC', 'AB')
FROM SYSIBM.SYSDUMMY1;
```

The result is the string 'ABCABC'.

Related concepts

Character strings

A *character string* is a sequence of bytes. The length of the string is the number of bytes in the sequence. If the length is zero, the value is called the *empty string*. The empty string should not be confused with the null value.

Binary strings

A *binary string* is a sequence of bytes.

Graphic strings

A *graphic string* is a sequence of double-byte characters.

RID scalar function

The RID function returns the record ID (RID) of a row. The RID is used to uniquely identify a row.

►► RID(*table-designator*) ◄◄

The schema is SYSIBM.

The function might return a different value when it is invoked multiple times for a row. For example, after the REORG utility is run, the RID function might return a different value for a row than would have been returned prior to the REORG utility being run. The RID function is not deterministic.

table-designator

table-designator must be an exposed name that uniquely identifies a base table, a view, or a nested table expression of a subselect in which the function is referenced.

If *table-designator* specifies a view or a nested table expression, the RID function returns the RID of the base table of the view or nested table expression. The specified view or nested table expression must contain only one base table in its outer subselect.

table-designator must not identify:

- A table function
- A collection-derived table
- An alias, a synonym, or a materialized view
- A nested table expression that is materialized
- A system-period temporal table, if the system time sensitive bind option is YES
- An archive-enabled table, if one of the following conditions is true:
 - For a static statement, the archive sensitive option in effect is YES.
 - For a dynamic statement, the archive sensitive option in effect is YES, and the GET_ARCHIVE built-in global variable is set to 'Y'.

The result of the function is BIGINT. The result can be null.

Notes

Considerations for RID values:

Db2 might reuse RID numbers when a REORG operation is performed. If the RID function is used to obtain a value for a row and an application depends on that value remaining the same as long as the row exists, consider the following alternatives:

- Add a ROWID column to the table to provide a value that can be associated with each row, rather than invoking the RID function to generate a value for a row.
- Define a primary key for the table, using the columns of the primary key to ensure uniqueness, rather than invoking the RID function to generate a value for a row.

Examples

Example 1:

Return the RID and last name of employees who are in department '20':

```
SELECT RID(EMP), LASTNAME
FROM EMP
WHERE DEPTNO = '20';
```

Example 2:

Return the RID and last name of employees who are in department '20', in a query that specifies a correlation name of A for table EMP. A is the exposed name for table EMP, so it is used as the argument to the RID function.

```
SELECT RID(A), LASTNAME
FROM EMP AS A
WHERE DEPTNO = '20';
```

If EMP is specified as the argument to the RID function instead of the exposed name, A, an error is returned.

Example 3:

Set the host variable *HV_EMP_RID* as the value of the RID for the employee with the employee number of '3500':

```
SELECT RID(EMP) INTO :HV_EMP_RID
FROM EMP
WHERE EMPNO = '3500';
```

RIGHT scalar function

The RIGHT function returns a string that consists of the specified number of rightmost bytes or specified string unit from a string.

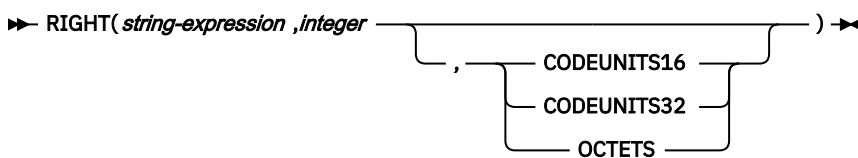

The schema is SYSIBM.

string-expression

An expression that specifies the string from which the result is derived. The string must be any built-in string data type. A substring of *string-expression* is zero or more contiguous code points of *string-expression*. A partial surrogate character in the expression is replaced with a blank.

The string can contain mixed data. Depending on the units that are specified to evaluate the function, the result is not necessarily a properly formed mixed data character string.

The argument can also be a numeric data type. The numeric argument is implicitly cast to a VARCHAR data type.

integer

An expression that specifies the length of the result. The value must be an integer between 0 and *n*, where *n* is the length attribute of *string-expression*, expressed in the units that are either implicitly or explicitly specified.

The argument can also be a character string or graphic string data type. The string input is implicitly cast to a numeric value of DECFLOAT(34) which is then assigned to an INTEGER value.

If CODEUNITS16 or CODEUNITS32 is specified, see [“Determining the length attribute of the final result” on page 108](#) for information about how to calculate the length attribute of the result string.

CODEUNITS16, CODEUNITS32, or OCTETS

Specifies the unit that is used to express *integer*. If *string-expression* is a character string that is defined as bit data, CODEUNITS16 and CODEUNITS32 cannot be specified. If *string-expression* is a graphic string, OCTETS cannot be specified. If *string-expression* is a binary string, CODEUNITS16, CODEUNITS32, and OCTETS cannot be specified.

CODEUNITS16

Specifies that *integer* is expressed in terms of 16-bit UTF-16 code units.

CODEUNITS32

Specifies that *integer* is expressed in terms of 32-bit UTF-32 code units.

OCTETS

Specifies that *integer* is expressed in terms of bytes.

For more information about CODEUNITS16, CODEUNITS32, and OCTETS, see [“String unit specifications”](#) on page 106.

The *string-expression* is effectively padded on the right with the necessary number of padding characters so that the specified substring of *string-expression* always exists. The encoding scheme of the data determines the padding character:

- For ASCII SBCS data or ASCII mixed data, the padding character is X'20'.
- For ASCII DBCS data, the padding character depends on the CCSID; for example, for Japanese (CCSID 301) the padding character is X'8140', while for simplified Chinese it is X'A1A1'.
- For EBCDIC SBCS data or EBCDIC mixed data, the padding character is X'40'.
- For EBCDIC DBCS data, the padding character is X'4040'.
- For Unicode SBCS data or UTF-8 data (Unicode mixed data), the padding character is X'20'.
- For UTF-16 data (Unicode DBCS data), the padding character is X'0020'.
- For binary data, the padding character is X'00'.

The result of the function is a varying-length string with a length attribute that is the same as the length attribute of *string-expression* and a data type that depends on the data type of *string-expression*:

- VARBINARY if *string-expression* is BINARY or VARBINARY
- VARCHAR if *string-expression* is CHAR or VARCHAR
- CLOB if *string-expression* is CLOB
- VARGRAPHIC if *string-expression* is GRAPHIC or VARGRAPHIC
- DBCLOB if *string-expression* is DBCLOB
- BLOB if *string-expression* is BLOB

The actual length of the result is determined from *integer*.

The result can be null; if any argument is null, the result is the null value.

The CCSID of the result is the same as that of *string-expression*.

Notes

Syntax alternatives:

[FL 506 STRRIGHT](#) is a synonym for RIGHT.

Examples

Example 1: Assume that host variable *ALPHA* has a value of 'ABCDEF'. The following statement returns the value 'DEF', which are the three rightmost characters in *ALPHA*.

```
SELECT RIGHT(ALPHA,3)
FROM SYSIBM.SYSDUMMY1;
```

Example 2: The following statement returns a zero length string.

```
SELECT RIGHT('ABCABC',0)
FROM SYSIBM.SYSDUMMY1;
```

Example 3: FIRSTNME is a VARCHAR(12) column in table T1. When FIRSTNME has the 6-character string 'Jürgen' as a value:

Function ...	Returns ...
RIGHT(FIRSTNME,5, CODEUNITS32)	'ürgen' -- x'C3BC7267656E'

```
RIGHT(FIRSTNME,5,CODEUNITS16)    'ürgen' -- x'C3BC7267656E'
RIGHT(FIRSTNME,5,OCTETS)        ' rgen' -- x'207267656E' A truncated string
```

Example 4: In the following example, the last invocation of the RIGHT function returns a partial surrogate character:

```
Function ...           Returns ...
RIGHT('Jürgen',5,CODEUNITS32)  'ürgen' -- x'C3BC7267656E'
RIGHT('Jürgen',5,CODEUNITS16)  'ürgen' -- x'C3BC7267656E'
RIGHT('Jürgen',5,OCTETS)       ' rgen' -- x'207267656E' A truncated string
HEX(RIGHT('Jürgen',5))        x'BC7267656E' -- A partial character followed by 'rgen'
```

ROUND scalar function

The ROUND function returns a number that is rounded to the specified number of places to the right or left of the decimal place.

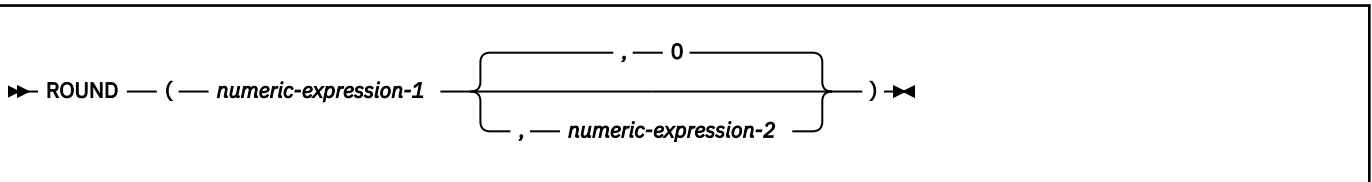

The schema is SYSIBM.

numeric-expression-1

An expression that returns a value of any built-in numeric data type.

If *expression-1* is a decimal floating-point data type, the DECFLOAT ROUNDING MODE will not be used. The rounding behavior of ROUND corresponds to a value of ROUND_HALF_UP. If you want a different rounding behavior, use the QUANTIZE function.

The argument can also be a character string or graphic string data type. The string input is implicitly cast to a numeric value of DECFLOAT(34).

numeric-expression-2

An expression that returns a value that is a built-in numeric, character string or graphic string data type. If the value is not of type INTEGER, it is implicitly cast to INTEGER before evaluating the function.

The absolute value of integer specifies the number of places to the right of the decimal point for the result if *numeric-expression-2* is not negative. If *numeric-expression-2* is negative, *numeric-expression-1* is rounded to the sum of the absolute value of *numeric-expression-2*+1 number of places to the left of the decimal point.

If the absolute value of *numeric-expression-2* is larger than the number of digits to the left of the decimal point, the result is 0. (For example, ROUND(748.58, -4) returns 0.)

If *numeric-expression-1* is positive, a digit value of 5 is rounded to the next higher positive number. If *numeric-expression-1* is negative, a digit value of 5 is rounded to the next lower negative number.

The result of the function has the same data type and length attribute as the first argument except that the precision is increased by one if the argument is DECIMAL and the precision is less than 31. For example, an argument with a data type of DECIMAL(5,2) results in DECIMAL(6,2). An argument with a data type of DECIMAL(31,2) results in DECIMAL(31,2).

The result can be null; if any argument is null, the result is the null value.

Example 1: Calculate the number '873.726' rounded to '2', '1', '0', '-1', and '-2' decimal places respectively.

```
SELECT ROUND(873.726,2),
       ROUND(873.726,1),
       ROUND(873.726,0),
       ROUND(873.726,-1),
       ROUND(873.726,-2),
```

```

ROUND(873.726,-3),
ROUND(873.726,-4)
FROM SYSIBM.SYSDUMMY1;

```

This example returns the values '0873.730', '0873.700', '0874.000', '0870.000', '0900.000', '1000.000', and '0000.000'.

Example 2: To demonstrate how numbers are rounded in positive and negative values, calculate the numbers '3.5', '3.1', '-3.1', '-3.5' rounded to '0' decimal places.

```

SELECT ROUND(3.5,0),
       ROUND(3.1,0),
       ROUND(-3.1,0),
       ROUND(-3.5,0)
FROM SYSIBM.SYSDUMMY1;

```

This example returns the values '04.0', '03.0', '-03.0', and '-04.0'. (Notice that in the positive value '3.5' is rounded up to the next higher number while in the negative value '-3.5' is rounded down to the next lower negative number.)

ROUND_TIMESTAMP scalar function

The ROUND_TIMESTAMP scalar function returns a timestamp that is rounded to the unit that is specified by the timestamp format string. If *format-string* is not specified, *expression* is rounded to the nearest day, as if 'DD' was specified for format-string.



The schema is SYSIBM.

expression

FL 507 An expression that returns a value of any of the following built-in data types: a date, a timestamp, a character string, or a graphic string. If *expression* is a character or graphic string, it must not be a CLOB or DBCLOB, and its value must be a valid string representation of a timestamp with an actual length that is not greater than 255 bytes. A time zone in a string representation of a timestamp is ignored. For the valid formats of string representations of dates and timestamps, see [“String representations of datetime values” on page 120](#).

Passthrough-only support: **FL 507** If *expression* is a date, Db2 passes the function through to IBM Db2 Analytics Accelerator as a passthrough-only expression. For more information, see [Accelerating queries with passthrough-only expressions](#).

format-string

An expression that returns a built-in character string or graphic string data type, with a length that is not greater than 255 bytes. *format-string* contains a template of how the timestamp represented by *expression* should be rounded. For example, if *format-string* is 'DD', the timestamp that is represented by *expression* is rounded to the nearest day. *format-string* must be a valid template for a timestamp, and not include leading or trailing blanks.

Allowable values for *format-string* are listed in the following table.

Table 88. ROUND_TIMESTAMP and TRUNC_TIMESTAMP format models

Format model	Description of rounding or truncating for the format model	ROUND_TIMESTAMP example	TRUNC_TIMESTAMP example
CC SCC	Century. One greater than the first two digits of a four digit year. For ROUND_TIMESTAMP, rounds up on the 50th year of the century.	Input Value: 1897-12-04-12.22.22.000000 Result: 1901-01-01-00.00.00.000000	Input Value: 1897-12-04-12.22.22.000000 Result: 1801-01-01-00.00.00.000000
SYYYY YYYY YEAR SYEAR YYY YY Y	Year. For ROUND_TIMESTAMP, rounds up on July 1 to January 1st of the next year.	Input Value: 1897-12-04-12.22.22.000000 Result: 1898-01-01-00.00.00.000000	Input Value: 1897-12-04-12.22.22.000000 Result: 1897-01-01-00.00.00.000000
IYYY IYY IY I	ISO year. For ROUND_TIMESTAMP, rounds up on July 1 to the first day of the next ISO year. The first day of the ISO year is defined as the Monday of the first ISO week.	Input Value: 1897-12-04-12.22.22.000000 Result: 1898-01-03-00.00.00.000000	Input Value: 1897-12-04-12.22.22.000000 Result: 1897-01-04-00.00.00.000000
Q	Quarter. For ROUND_TIMESTAMP, rounds up on the 16th day of the second month of the quarter.	Input Value: 1999-06-04-12.12.30.000000 Result: 1999-07-01-00.00.00.000000	Input Value: 1999-06-04-12.12.30.000000 Result: 1999-04-01-00.00.00.000000
MONTH MON MM RM	Month. For ROUND_TIMESTAMP, rounds up on the 16th day of the month.	Input Value: 1999-06-18-12.12.30.000000 Result: 1999-07-01-00.00.00.000000	Input Value: 1999-06-18-12.12.30.000000 Result: 1999-06-01-00.00.00.000000

Table 88. ROUND_TIMESTAMP and TRUNC_TIMESTAMP format models (continued)

Format model	Description of rounding or truncating for the format model	ROUND_TIMESTAMP example	TRUNC_TIMESTAMP example
WW	Same day of the week as the first day of the year. For ROUND_TIMESTAMP, rounds up on the 12th hour of the 4th day of the week, with respect to the first day of the year.	Input Value: 2000-05-05-12.12.30.000000 Result: 2000-05-06-00.00.00.000000	Input Value: 2000-05-05-12.12.30.000000 Result: 2000-04-29-00.00.00.000000
IW	Same day of the week as the first day of the ISO year. For ROUND_TIMESTAMP, rounds up on the 12th hour of the 4th day of the week, with respect to the first day of the ISO year.	Input Value: 2000-05-05-12.12.30.000000 Result: 2000-05-08-00.00.00.000000	Input Value: 2000-05-05-12.12.30.000000 Result: 2000-05-01-00.00.00.000000
W	Same day of the week as the first day of the month. For ROUND_TIMESTAMP, rounds up on the 12th hour of the 4th day of the week, with respect to the first day of the month.	Input Value: 2000-06-21-12.12.30.000000 Result: 2000-06-22-00.00.00.000000	Input Value: 2000-06-21-12.12.30.000000 Result: 2000-06-15-00.00.00.000000
DDD DD J	Day. For ROUND_TIMESTAMP, rounds up on the 12th hour of the day.	Input Value: 2000-05-17-12.59.59.000000 Result: 2000-05-18-00.00.00.000000	Input Value: 2000-05-17-12.59.59.000000 Result: 2000-05-17-00.00.00.000000
DAY DY D	Starting day of the week. For ROUND_TIMESTAMP, rounds up with respect to the 12th hour of the 4th day of the week. The first day of the week is always Sunday.	Input Value: 2000-05-17-12.59.59.000000 Result: 2000-05-21-00.00.00.000000	Input Value: 2000-05-17-12.59.59.000000 Result: 2000-05-14-00.00.00.000000

Table 88. ROUND_TIMESTAMP and TRUNC_TIMESTAMP format models (continued)

Format model	Description of rounding or truncating for the format model	ROUND_TIMESTAMP example	TRUNC_TIMESTAMP example
HH HH12 HH24	Hour. For ROUND_TIMESTAMP, rounds up at 30 minutes.	Input Value: 2000-05-17-23.59.59.000000 Result: 2000-05-18-00.00.00.000000	Input Value: 2000-05-17-23.59.59.000000 Result: 2000-05-17-23.00.00.000000
MI	Minute. For ROUND_TIMESTAMP, rounds up at 30 seconds.	Input Value: 2000-05-17-23.58.45.000000 Result: 2000-05-17-23.59.00.000000	Input Value: 2000-05-17-23.58.45.000000 Result: 2000-05-17-23.58.00.000000
SS	Second. For ROUND_TIMESTAMP, rounds up at 500000 microseconds.	Input Value: 2000-05-17-23.58.45.500000 Result: 2000-05-17-23.58.46.000000	Input Value: 2000-05-17-23.58.45.500000 Result: 2000-05-17-23.58.45.000000

If *expression* does not have data type `TIMESTAMP WITHOUT TIME ZONE`, *expression* is cast as follows:

- If *expression* is a `TIMESTAMP WITH TIME ZONE` value, *expression* is cast to `TIMESTAMP WITHOUT TIME ZONE`, with the same precision as *expression*.
- Otherwise, *expression* is cast to `TIMESTAMP(6) WITHOUT TIME ZONE`.

The result of the function has the same data type as the data type to which *expression* is cast.

The result can be null; if any argument is null, the result is the null value.

The result CCSID is the appropriate CCSID of the argument encoding scheme and the result subtype is the appropriate subtype of the CCSID.

Examples

- Set the host variable `RND_TMSTMP` with the input timestamp rounded to the nearest year value.

```
SET :RND_TMSTMP = ROUND_TIMESTAMP(TIMESTAMP_FORMAT('2000-08-14 17:30:00',
                                                    'YYYY-MM-DD HH24:MI:SS'), 'YEAR');
```

The value set is '2001-01-01-00.00.00.000000'.

- Assume `PRSTSZ` is an SQL variable with the `TIMESTAMP WITH TIME ZONE` value '2008-04-15.20.00.000000-08:30'. The input value is first cast to `TIMESTAMP WITHOUT TIME ZONE` (as '2008-04-15.20.00.000000') for the `ROUND_TIMESTAMP` function.

```
SELECT ROUND_TIMESTAMP(PRSTSZ)
FROM PROJECT;
```

The `ROUND_TIMESTAMP` function returns a `TIMESTAMP WITHOUT TIME ZONE` value of '2008-04-16.00.00.000000'.

ROWID scalar function

The ROWID function returns a row ID representation of its argument.

►► ROWID(*expression*) ◄◄

The schema is SYSIBM.

The argument must be an expression that returns a value of a built-in character string data type, other than a CLOB, with a maximum length that is no greater than 255 bytes. Although the character string can contain any value, it is recommended that the character string contain a ROWID value that was previously generated by Db2 to ensure a valid ROWID value is returned. For example, the function can be used to convert a ROWID value that was cast to a CHAR value back to a ROWID value.

If the actual length of *expression* is less than 40, the result is not padded. If the actual length of *expression* is greater than 40, the result is truncated. If non-blank characters are truncated, a warning is returned.

The result of the function is a ROWID value.

The length attribute of the result is 40. The actual length of the result is the length of *expression*.

The result can be null; if the argument is null, the result is the null value.

A null ROWID value cannot be used as the value for a row ID column in the database.

Examples

Example 1:

Assume that table EMPLOYEE contains a row ID column, 'EMP_ROWID'. Also assume that the table contains a row that is identified by a ROWID value that is equivalent to X'F0DFD230E3C0D80D81C201AA0A28010000000000203'. Using direct row access, select the employee number for that row.

```
SELECT EMPNO
FROM EMPLOYEE
WHERE EMP_ROWID=ROWID(X'F0DFD230E3C0D80D81C201AA0A28010000000000203');
```

RPAD scalar function

The RPAD function returns a string that is padded on the right with blanks or a specified string.

►► RPAD(*string-expression*, *integer*, *pad*) ◄◄

The schema is SYSIBM.

The RPAD function returns a string composed of *string-expression* padded on the right, with *pad* or blanks. The RPAD function treats leading or trailing blanks in *string-expression* as significant. Padding will only occur if the actual length of *string-expression* is less than *integer*, and *pad* is not an empty string.

string-expression

An expression that specifies the source string. The expression must return a value that is a built-in string data type that is not a LOB.

integer

An integer constant that specifies the length of the result. The value must be zero or a positive integer that is less than or equal to *n*, where *n* is 32704 if *string-expression* is a character or binary string, or where *n* is 16352 if *string-expression* is a graphic string.

pad

An expression that specifies the string with which to pad. The expression must return a value that is a built-in string data type that is not a LOB. If *pad* is not specified, the pad character is determined as follows:

- SBCS blank character if *string-expression* is a character string.
- DBCS blank character if *string-expression* is a graphic string.
- Hexadecimal zero (X'00'), if *string-expression* is a binary string.

The result of the function is a varying length string that has the same CCSID of *string-expression*. *string-expression* and *pad* must have compatible data types. If the string expressions have different CCSID sets, then *pad* is converted to the CCSID set of *string-expression*. If either *string-expression* or *pad* is FOR BIT DATA, no character conversion occurs. The actual length of the result is determined from *integer*.

The length attribute of the result depends on *integer*. If *integer* is greater than 0, the length attribute of the result is *integer*. If *integer* is 0, the length attribute of the result is 1.

The actual length of the result is determined from *integer*. If *integer* is 0, the actual length is 0, and the result is the empty string. If *integer* is less than the actual length of *string-expression*, the actual length is *integer* and the result is truncated.

The result can be null; if any argument is null, the result is the null value.

Example 1: Assume that NAME is a VARCHAR(15) column that contains the values 'Chris', 'Meg', and 'Jeff'. The following query will completely pad out a value on the right with periods.

```
SELECT RPAD(NAME,15,'.' ) AS NAME
FROM T1;
```

The results are similar to the following output:

```
NAME
-----
Chris.....
Meg.....
Jeff.....
```

Example 2: Similar to Example 1, the following query will completely pad out a value on the right with *pad* (note that in some cases there is a partial instance of the padding specification):

```
SELECT RPAD(NAME,15,'123' ) AS NAME
FROM T1;
```

The results are similar to the following output:

```
NAME
-----
Chris1231231231
Meg123123123123
Jeff12312312312
```

Example 3: Similarly, the following query will only pad each value to a length of 5:

```
SELECT RPAD(NAME,5,'.') AS NAME
FROM T1;
```

The results are similar to the following output:

```
NAME
-----
Chris
Meg..
Jeff.
```

Example 4: Assume that NAME is a CHAR(15) column that contains the values 'Chris', 'Meg', and 'Jeff'. Note that the result of RTRIM in the following example is a varying length string with the blanks removed:

```
SELECT RPAD(RTRIM(NAME),15,'.') AS NAME
FROM T1;
```

The results are similar to the following output:

```
NAME
-----
Chris.....
Meg.....
Jeff.....
```

RTRIM scalar function

The RTRIM function removes bytes from the end of a string expression based on the content of a trim expression.

► RTRIM (— *string-expression* — , — *trim-expression* —) ◄

The schema is SYSIBM.

The RTRIM function removes all of the characters contained in *trim-expression* from the end of *string-expression*. The search is done by comparing the binary representation of each character (which consists of one or more bytes) in *trim-expression* to the bytes at the end of *string-expression*. If *string-expression* is defined as FOR BIT DATA, the search is done by comparing each byte in *trim-expression* to the byte at the end of *string-expression*.

string-expression

An expression that specifies the source string. The argument must be an expression that returns a value that is a built-in string data type that is not a LOB, or a numeric data type. If the value is not a string data type, it is implicitly cast to VARCHAR before the function is evaluated. If *string-expression* is not FOR BIT DATA, *trim-expression* must not be FOR BIT DATA.

trim-expression

An expression that specifies the characters to remove from the end of *string-expression*. The expression must return a value that is a built-in string data type that is not a LOB, or a numeric data type. If the value is not a string data type, it is implicitly cast to VARCHAR before the function is evaluated.

The default for *trim-expression* depends on the data type of *string-expression*:

- A DBCS blank if *string-expression* is a DBCS graphic string. For ASCII, the CCSID determines the hex value that represents a DBCS blank. For example, for Japanese (CCSID 301), X'8140' represents a DBCS blank, while for Simplified Chinese, X'A1A1' represents a DBCS blank. For EBCDIC, X'4040' represents a DBCS blank.
- A UTF-16 or UCS-2 blank (X'0020') if *string-expression* is a Unicode graphic string.
- A value of X'00' if *string-expression* is a binary string.
- Otherwise, a single byte blank. For EBCDIC, X'40' represents a blank. When not EBCDIC, X'20' represents a blank.

string-expression and *trim-expression* must have compatible data types. If *string-expression* and *trim-expression* have different CCSID sets, *trim-expression* is converted to the CCSID of *string-expression*.

The result of the function depends on the data type of *string-expression*.

- VARCHAR if *string-expression* is a character string. If *string-expression* is defined as FOR BIT DATA, the result is FOR BIT DATA.
- VARGRAPHIC if *string-expression* is a graphic string.

- VARBINARY if *string-expression* is a binary string.

The length attribute of the result is the same as the length attribute of *string-expression*.

The actual length of the result for a character or binary string is the length of *string-expression* minus the number of bytes removed. The actual length of the result for a graphic string is the length (in number of double byte characters) of *string-expression* minus the number of double byte characters removed. If all of the characters are removed, the result is an empty string (the length is zero).

The result can be null; if the argument is null, the result is the null value.

The CCSID of the result is the same as that of *string-expression*.

Notes

Valid content for EBCDIC mixed string input:

If *string-expression* is an EBCDIC mixed string, the string must contain valid EBCDIC mixed data.

Examples

Example: Use the RTRIM function to remove individual numbers in the second argument from the end (right side) of the first argument:

```
SELECT RTRIM ('123DEFG123', '321'),
       RTRIM ('12322XYZ1232222', '123'),
       RTRIM ('12321', '213'),
       RTRIM ('123XYX', '321')
FROM SYSIBM.SYSDUMMY1
```

The result is '123DEFG', '12322XYZ', '' (empty string - all characters removed), and '123XYX' (no characters removed).

The RTRIM function does not remove instances of '1', '2', and '3' at the beginning of the string, before characters that are not '1', '2', or '3'.

Example: Use the RTRIM function to remove individual characters in the second argument from the end (right side) of the first argument:

```
SELECT RTRIM ('((-78.0))', '-0.()')
FROM SYSIBM.SYSDUMMY1
```

The result is '((-78'.

Example: Use the RTRIM function to remove dollar signs and periods in the second argument from the end (right side) of the first argument:

```
SELECT RTRIM ('...$VAR$...', '$.')
FROM SYSIBM.SYSDUMMY1
```

The result is '...\$VAR'.

SCORE scalar function

The SCORE function searches a text search index using criteria that are specified in a search argument and returns a relevance score that measures how well a document matches the query.

Requirement: To use the SCORE function, Text Search for Db2 for z/OS must be installed and configured. See [IBM Text Search for Db2 for z/OS \(IBM Text Search for Db2 for z/OS Installation, Administration, and Reference\)](#) for more information.

►► SCORE — (— *column-name* — , — *search-argument* —) ►►
 , — *string-constant* ¹

Notes:

¹ *string-constant* must conform to the rules for the *search-argument-options*.

search-argument-options

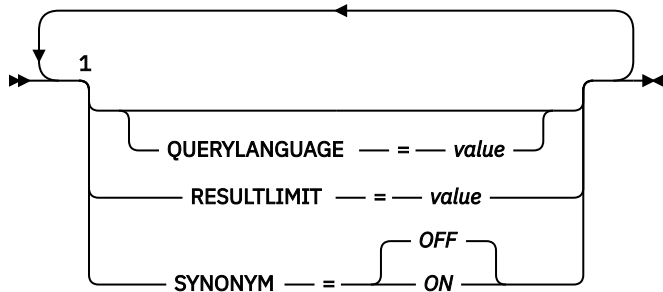

Notes:

¹ The same clause must not be specified more than once.

The schema is SYSIBM.

column-name

Specifies a qualified or unqualified name of a column that has a text search index that is to be searched. The column must exist in the table or view that is identified in the FROM clause in the statement and the column of the table, or the column of the underlying base table of the view must have an associated text search index. The underlying expression of the column of a view must be a simple column reference to the column of an underlying table, either directly or through another nested view.

search-argument

Specifies an expression that returns a value that is a string value (except a LOB) that contains the terms to be searched for and must not be all blanks or the empty string. The actual length of the string must not exceed 4096 Unicode characters. The value is converted to Unicode before it is used to search the text search index. The maximum number of terms per query must not exceed 1024.

string-constant

Identifies a string constant that specifies the search argument options that are in effect for the function.

The options that can be specified as part of the *search-argument-options* are as follows:

QUERYLANGUAGE = value

Specifies the query language. The value can be any of the supported language codes. If the QUERYLANGUAGE option is not specified, the default is the language value of the text search index that is used when this function is invoked. If the language value of the text search index is AUTO, the default value for QUERYLANGUAGE is en_US.

RESULTLIMIT = value

Specifies the maximum number of results that are to be returned from the underlying search engine. The *value* can be an integer value in the range 1–2 147 483 647. If the RESULTLIMIT option is not specified, no result limit is in effect for the query.

This scalar function cannot be called for each row of the result table, depending on the plan that the optimizer chooses. This function can be called once for the query to the underlying search engine, and a result set of all of the primary keys that match are returned from the search engine. This result set is then joined to the table containing the column to identify the result rows. In this case, the RESULTLIMIT value acts like a FETCH FIRST ?? ROWS from the underlying text search engine and can be used as an optimization. If the search engine is called for each row of the result because the optimizer determines that is the best plan, then the RESULTLIMIT option has no effect.

SYNONYM = OFF or SYNONYM = ON

Specifies whether to use a synonym dictionary that is associated with the text search index. Use the Synonym Tool to add a synonym dictionary to the collection. The default is OFF.

OFF

Do not use a synonym dictionary.

ON

Use the synonym dictionary that is associated with the text search index.

The result of the function is a double-precision floating-point number. If the second argument can be null, the result can be null. If the second argument is null, the result is the null value. If the third argument is null, the result is as if the third argument was not specified.

The result is greater than 0 but less than 1 if the column contains a match for the search criteria that the search argument specifies. The better a document matches the query, the more relevant the score and the larger the result value. If the column does not contain a match, the result is 0.

Notes**Determinism:**

SCORE is a non-deterministic function.

Examples

Assume that information about employees' skills are stored in a table named EMP_RESUME. The following statement generates a list of employees in the order of how well their resumes matches the query "programmer AND (java OR cobol)", along with a relevance value that is normalized between 0 (zero) and 100.

```
SELECT EMPNO, INTEGER(SCORE(RESUME, 'programmer AND
(java OR cobol)') * 100) AS RELEVANCE
FROM EMP_RESUME
WHERE RESUME_FORMAT = 'ascii'
AND CONTAINS(RESUME, 'programmer AND (java OR cobol)') = 1
ORDER BY RELEVANCE DESC
```

Db2 first evaluates the CONTAINS predicate in the WHERE clause, and therefore, does not evaluate the SCORE function in the SELECT list for every row of the table. In this case, the arguments for SCORE and CONTAINS must be identical.

SECOND scalar function

The SECOND function returns the seconds part of a value with optional fractional seconds.

►► SECOND(*expression* , — *integer-constant*) ◄◄

The schema is SYSIBM.

expression

expression must be an expression that returns a value of one of the following built-in data types: a time, a timestamp, a character string, a graphic string, or a numeric data type.

- If *expression* is a character or graphic string, it must not be a CLOB or DBCLOB, and its value must be a valid string representation of a time or timestamp with an actual length that is not greater than 255 bytes. For the valid formats of string representations of times and timestamps, see [“String representations of datetime values”](#) on page 120.
- If *expression* is a number, it must be a time or timestamp duration. For the valid formats of time and timestamp durations, see [“Datetime operands”](#) on page 169.

integer-constant

integer-constant must be an integer constant that represents the scale for the fractional seconds portion of *expression*. The value must be in the range 0 through 12. If *integer-constant* is not specified, the result does not include fractional seconds.

If *expression* is a timestamp with a time zone, or a valid string representation of a timestamp with a time zone, the result is determined from the UTC representation of the datetime value.

The result of the function with a single argument is a large integer. The result of the function with two arguments is DECIMAL(2+s,s) where s is the value of *integer-constant*.

The result can be null; if the first argument is null, the result is the null value.

The other rules depend on the data type of the argument:

If the argument is a time, timestamp, or string representation of a time or a timestamp:

The result is the seconds part of the value (0 to 59) and any fractional seconds that are included in the value. If the second argument is specified, the result includes *integer-constant* digits of the fractional seconds part of the value where applicable. If there are no fractional seconds in the value, zeros are returned.

If the argument is a time duration or timestamp duration:

The result is the seconds part of the value (-99 to 99) and any fractional seconds that are included in the value. If the second argument is specified, the result includes *integer-constant* digits of the fractional seconds part of the value where applicable. If there are no fractional seconds in the value, zeros are returned. A nonzero result has the same sign as the *expression*.

Example 1: Assume that the variable *TIME_DUR* is declared in a PL/I program as DECIMAL(6,0) and can therefore be interpreted as a time duration. When *TIME_DUR* has the value 153045, the following function returns the value 45.

```
SECOND(:TIME_DUR)
```

Example 2: Assume that RECEIVED is a TIMESTAMP column and that one of its values is the internal equivalent of '1988-12-25-17.12.30.000000'. The following function returns the value 30.

```
SECOND(RECEIVED)
```

Example 3: The following invocations of the SECOND function returns the same result:

```
SELECT SECOND('2003-01-02-20.10.05.123456'),
        SECOND('2003-01-02-12.10.05.123456-08:00'),
        SECOND('2003-01-03-05.10.05.123456+09:00')
FROM SYSIBM.SYSDUMMY1;
```

For each invocation of the SECOND function in this SELECT statement, the result is 5.

When the input argument contains a time zone, the result is determined from the UTC representation of the input value. The string representations of a timestamp with a time zone in the SELECT statement all have the same UTC representation: 2003-01-02-20.10.05.123456. The second portion of the UTC representation is 5.

Example 4: Return the seconds with fractional seconds from a current timestamp with milliseconds.

```
SELECT SECOND(CURRENT_TIMESTAMP(3),3)
FROM SYSIBM.SYSDUMMY1;
```

The SELECT statement returns a DECIMAL(5,3) value that is based on the current timestamp and could be something like 54.321.

SIGN scalar function

The SIGN function returns an indicator of the sign of the argument.

►► SIGN(*numeric-expression*) ◄◄

The schema is SYSIBM.

The returned value is one of the following values:

- 1**
if the argument is less than zero
- 0**
if the argument is DECFLOAT negative zero
- 0**
if the argument is zero
- 1**
if the argument is greater than zero

The argument must be an expression that returns a value of any built-in numeric data type, except DECIMAL(31,31).

The argument can also be a character string or graphic string data type. The string input is implicitly cast to a numeric value of DECFLOAT(34).

The result has the same data type and length attribute as the argument, except that precision is increased by one if the argument is DECIMAL and the scale of the argument is equal to its precision. For example, an argument with a data type of DECIMAL(5,5) will result in DECIMAL(6,5).

The result can be null; if the argument is null, the result is the null value.

Example: Assume that host variable *PROFIT* is a large integer with a value of 50000.

```
SELECT SIGN(:PROFIT)
FROM SYSIBM.SYSDUMMY1;
```

This example returns the value 1.

SIN scalar function

The SIN function returns the sine of the argument, where the argument is an angle, expressed in radians.

►► SIN(*numeric-expression*) ◄◄

The schema is SYSIBM.

The SIN and ASIN functions are inverse operations.

The argument must be an expression that returns the value of any built-in numeric data type that is not DECFLOAT. If the argument is not a double precision floating-point number, it is converted to one for processing by the function.

The result of the function is a double precision floating-point number.

The result can be null; if the argument is null, the result is the null value.

Example: Assume that host variable *SINE* is DECIMAL(2,1) with a value of 1.5. The following statement returns a double precision floating-point number with an approximate value of 0.99.

```
SELECT SIN(:SINE)
FROM SYSIBM.SYSDUMMY1;
```

SINH scalar function

The SINH function returns the hyperbolic sine of the argument, where the argument is an angle, expressed in radians.

►► SINH(*numeric-expression*) ◄◄

The schema is SYSIBM.

The argument must be an expression that returns the value of any built-in numeric data type that is not DECFLOAT. If the argument is not a double precision floating-point number, it is converted to one for processing by the function.

The result of the function is a double precision floating-point number.

The result can be null; if the argument is null, the result is the null value.

Examples

Example 1:

Assume that host variable *HSINE* is DECIMAL(2,1) with a value of 1.5. The following statement returns a double precision floating-point number with an approximate value of 2.12.

```
SELECT SINH(:HSINE)
FROM SYSIBM.SYSDUMMY1;
```

SMALLINT scalar function

The SMALLINT function returns a small integer representation either of a number or of a string representation of a number.

Numeric to Smallint:

►► SMALLINT(*numeric-expression*) ◄◄

String to Smallint:

►► SMALLINT(*string-expression*) ◄◄

The schema is SYSIBM.

Numeric to Smallint

numeric-expression

An expression that returns a value of any built-in numeric data type.

The result is the same number that would occur if the argument were assigned to a small integer column or variable. If the whole part of the argument is not within the range of small integers, an error occurs. If present, the decimal part of the argument is truncated.

String to Smallint

string-expression

An expression that returns a value of character or graphic string (except a CLOB or DBCLOB) with a length attribute that is not greater than 255 bytes for a character string or 127 for a graphic string. The string must contain a valid string representation of a number.

The result is the same number that would result from `CAST(string-expression AS SMALLINT)`. Leading and trailing blanks are eliminated and the resulting string must conform to the rules for forming an SQL integer constant.

The result of the function is a small integer.

The result can be null; if the argument is null, the result is the null value.

Notes

Syntax alternatives:

To increase the portability of applications, use the `CAST` specification. For more information, see [“CAST specification”](#) on page 267.

Examples

Example 1:

Using sample table `DSN8C10.EMP`, find the average education level (`EDLEVEL`) of the employees in department 'A00'. Round the result to the nearest full education level.

```
SELECT SMALLINT(AVG(EDLEVEL)+.5)
FROM DSN8C10.EMP
WHERE DEPT = 'A00';
```

Assuming that the five employees in the department have education levels of '19', '18', '14', '18', and '14', the result is '17'.

SOUNDEX scalar function

The `SOUNDEX` function returns a 4-character code that represents the sound of the words in the argument. The result can be compared to the results of the `SOUNDEX` function of other strings.

► `SOUNDEX(expression)` ◄

The schema is `SYSIBM`.

expression

An *expression* that must return a value of any built-in numeric, character, or graphic string data type that is not a LOB. A numeric, mixed character, or graphic string value is cast to a Unicode SBCS character string before the function is evaluated. For more information about converting numeric data to a character string, see [“VARCHAR scalar function”](#) on page 615. For more information about converting mixed or graphic strings to Unicode SBCS, see [“CAST specification”](#) on page 267.

The data type of the result is `CHAR(4)`.

The result can be null; if the argument is null, the result is the null value.

The CCSID of the result is the Unicode SBCS CCSID.

The `SOUNDEX` function is useful for finding strings for which the sound is known but the precise spelling is not. It makes assumptions about the way that letters and combinations of letters sound that can help to search for words with similar sounds. The comparison of words can be done directly or by passing the strings as arguments to the `DIFFERENCE` function. For more information, see [“DIFFERENCE scalar function”](#) on page 450.

Example 1: Use the `SOUNDEX` function to find a row where the sound of the `LASTNAME` value closely matches the phonetic spelling of 'Loucesy':

```
SELECT EMPNO, LASTNAME
FROM DSN910.EMPLOYEE
WHERE SOUNDEX(LASTNAME) = SOUNDEX('Loucesy');
```

This example returns the following row:

SOAPHTTPC and SOAPHTTPV scalar function

The SOAPHTTPC function returns a CLOB representation of XML data that results from a SOAP request to the web service that is specified by the first argument. The SOAPHTTPV function returns a VARCHAR representation of XML data that results from a SOAP request to the web service that is specified by the first argument.



The schema is DB2XML.

These functions are deprecated and might not be available in future releases of Db2.

endpoint_url

An expression that returns a value of a built-in character string or graphic string data type that is not a LOB. The value specifies the URL of the web service endpoint for which Db2 is acting as a client.

soap_action

An expression that returns a value of a built-in character string or graphic string data type that is not a LOB. The value specifies a SOAP action URI reference. If it is required for the web service that is specified in *endpoint_url*, the required value is defined in the WSDL of that web service.

soap_body

An expression that returns a value of a built-in character string data type that is defined as VARCHAR(3072) or CLOB(1M). The value specifies the name of an operation with the requested namespace URI, an encoding style, and input arguments. *soap_body* can include well-formed XML content for the SOAP body. The specific operations and arguments for a web service are defined in the WSDL of the specified web service.

If the arguments can be null, the result can be null; if all of the arguments are null, the result is the null value.

The result can be null; if all of the arguments are null, the result is the null value.

Example 1: The following SQL statement retrieves information (as VARCHAR data) about a web service:

```

SELECT DB2XML.SOAPHTTPV(
  'http://www.myserver.com/services/db2sample/ivt.dadx/SOAP',
  'http://tempuri.org/db2sample/ivt.dadx',
  '<testInstallation xmlns="http://tempuri.org/db2sample/ivt.dadx" />')
FROM SYSIBM.SYSDUMMY1

```

Example 2: The following SQL statement inserts the results (as CLOB data) from a request to a web service into a table:

```

INSERT INTO EMPLOYEE(XMLCOL)
VALUES (DB2XML.SOAPHTTPC(
  'http://www.myserver.com/services/db2sample/list.dadx/SOAP',
  'http://tempuri.org/db2sample/list.dadx',
  '<listDepartments xmlns="http://tempuri.org/db2sample/list.dadx">
  <deptNo>A00</deptNo>
</listDepartments>' ))

```

SOAPHTTPNC and SOAPHTTPNV scalar function

The SOAPHTTPNC and SOAPHTTPNV functions allow you to specify a complete SOAP message as input and to return complete SOAP messages from the specified web service. The returned SOAP messages are CLOB or VARCHAR representations of the returned XML data.

```
▶ SOAPHTTPNC (endpoint_url ,soap_action ,soap_input ) ▶◀  
  SOAPHTTPNV
```

The schema is DB2XML.

endpoint_url

Specifies the URL of the web service for which Db2 is acting as a client. *endpoint_url* is defined as a VARCHAR(4096) value. The URL is in the following format:

```
proto://[user[:password]@]hostname[:port]/[path]
```

Where *proto* can be http or https.

soap_action

Specifies a SOAP action URI reference. *soap_action* is defined as a VARCHAR(4096) value. Depending on the web server, *soap_action* might be required. If it is required for the web service that is specified in *endpoint_url*, the required value is defined in the WSDL of that web service.

soap_input

Specifies an XML document that contains the complete SOAP message. *soap_input* can contain optional SOAP headers and must contain a SOAP body that specifies the operation name and parameters to the web service. *soap_input* should be well-formed XML that is defined as VARCHAR(32672) or CLOB(1M).

Example 1: The following SQL statement retrieves information (as VARCHAR data) about a web service:

```
SELECT DB2XML.SOAPHTTPNV(  
  'http://rpc.geocoder.us/service/soap/',  
  'http://rpc.geocoder.us/Geo/Coder/US#geocode_address',  
  '<?xml version="1.0" encoding="UTF-8" ?>' ||  
  '<SOAP-ENV:Envelope ' ||  
  'xmlns:SOAP-ENV="http://schemas.xmlsoap.org/soap/envelope/" ' ||  
  'xmlns:xsd="http://www.w3.org/2001/XMLSchema" ' ||  
  'xmlns:xsi="http://www.w3.org/2001/XMLSchema-instance">' ||  
  '<SOAP-ENV:Body>' ||  
  '<ns0:geocode_address ' ||  
  'xmlns:ns0="http://rpc.geocoder.us/Geo/Coder/US/" ' ||  
  'SOAP-ENV:encodingStyle="http://schemas.xmlsoap.org/soap/encoding/">' ||  
  '<address xsi:type="xsd:string">555 Bailey Avenue, San Jose,' ||  
  'CA,95141</address>' ||  
  '</ns0:geocode_address>' ||  
  '</SOAP-ENV:Body>' ||  
  '</SOAP-ENV:Envelope>'  
FROM SYSIBM.SYSDUMMY1;
```

Example 2: The following SQL statement inserts the results (as CLOB data) from a request to a web service into a table:

```
INSERT INTO EMPLOYEE(XMLCOL)  
VALUES (DB2XML.SOAPHTTPNC(  
  'http://www.myserver.com/services/db2sample/list.dadx/SOAP',  
  'http://tempuri.org/db2sample/list.dadx',  
  '<?xml version="1.0" encoding="UTF-8" ?>' ||  
  '<SOAP-ENV:Envelope ' ||  
  'xmlns:SOAP-ENV="http://schemas.xmlsoap.org/soap/envelope/" ' ||  
  'xmlns:xsd="http://www.w3.org/2001/XMLSchema" ' ||  
  'xmlns:xsi="http://www.w3.org/2001/XMLSchema-instance">' ||  
  '<SOAP-ENV:Body>' ||  
  '<listDepartments xmlns="http://tempuri.org/db2sample/list.dadx">  
    <deptNo>A00</deptNo>  
  </listDepartments>' ||
```

```
'</SOAP-ENV:Body>' ||  
'</SOAP-ENV:Envelope>')
```

SPACE scalar function

The SPACE function returns a character string that consists of the number of SBCS blanks that the argument specifies.

► SPACE(*numeric-expression*) ◄

The schema is SYSIBM.

numeric-expression

An expression that returns the value of any built-in integer data type. The expression specifies the number of SBCS blanks for the result, and it must be between 0 and 32764.

The argument can also be a character string or graphic string data type. The string input is implicitly cast to a numeric value of DECFLOAT(34) which is then assigned to a BIGINT value.

The result of the function is a varying-length character string (VARCHAR) that contains SBCS data.

If *numeric-expression* is a constant, the length attribute of the result is the constant. Otherwise, the length attribute of the result is 4000. The actual length of the result is the value of *numeric-expression*. The actual length of the result must not be greater than the length attribute of the result.

The result can be null; if the argument is null, the result is the null value.

Example: The following statement returns a character string that consists of 5 blanks followed by a zero-length string.

```
SELECT SPACE(5), SPACE(0)  
FROM SYSIBM.SYSDUMMY1;
```

Related concepts

Character strings

A *character string* is a sequence of bytes. The length of the string is the number of bytes in the sequence. If the length is zero, the value is called the *empty string*. The empty string should not be confused with the null value.

SQRT scalar function

The SQRT function returns the square root of the argument.

► SQRT(*numeric-expression*) ◄

The schema is SYSIBM.

The argument must be an expression that returns the value of any built-in numeric data type. If the argument is DECFLOAT, the operation is performed in DECFLOAT. Otherwise, the argument is converted to a double precision floating-point number for processing by the functions.

The argument can also be a character string or graphic string data type. The string input is implicitly cast to a numeric value of DECFLOAT(34).

If the argument is DECFLOAT(*n*), the result is DECFLOAT(*n*). Otherwise, the result of the function is a double precision floating-point number. If the argument is a special decimal floating point value, the general rules for arithmetic operations apply. For more information, see [“General arithmetic operation rules for DECFLOAT” on page 254](#)

The result can be null; if the argument is null, the result is the null value.

Example: Assume that host variable *SQUARE* is defined as *DECIMAL(2,1)* and has a value of 9.0. Find the square root of *SQUARE*.

```
SELECT SQRT(:SQUARE)
FROM SYSIBM.SYSDUMMY1;
```

This example returns a double precision floating-point number with an approximate value of 3.

STRIP scalar function

The STRIP function removes blanks or another specified character from the end, the beginning, or both ends of a string expression.

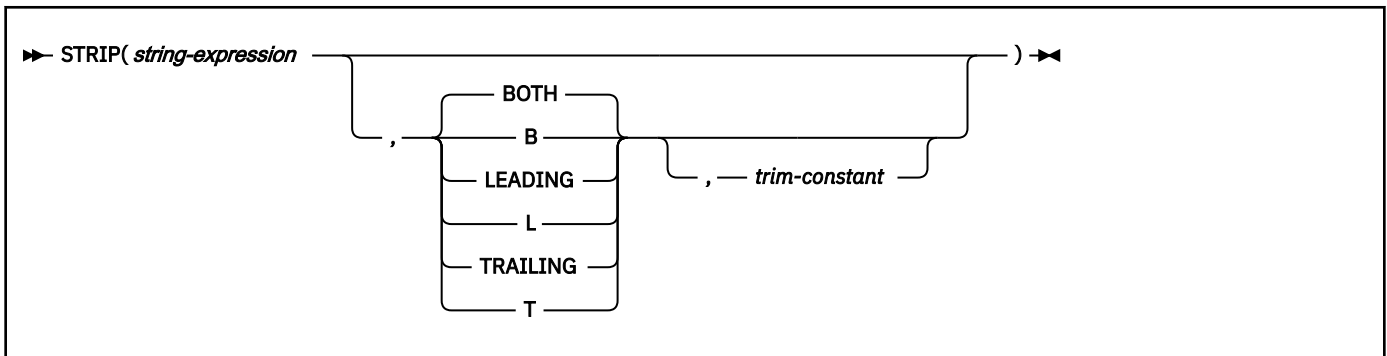

The schema is SYSIBM.

The STRIP function is similar to the TRIM scalar function.

Notes

Valid content for EBCDIC mixed string input:

If *string-expression* is an EBCDIC mixed string, the string must contain valid EBCDIC mixed data.

Related reference

[TRIM scalar function](#)

The TRIM function removes bytes from the beginning, from the end, or from both the beginning and end of a string expression.

STRLEFT scalar function

The STRLEFT function returns a string that consists of the specified number of leftmost bytes of the specified string units.

[FL 506](#)

Character string:

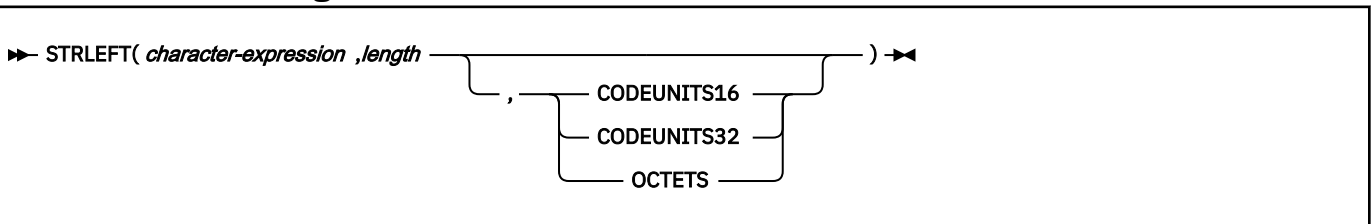

The STRLEFT function is identical to the LEFT function. For more information, see [“LEFT scalar function” on page 487](#).

STRPOS scalar function

The STRPOS function returns the position of the first occurrence of an argument within another argument.

[FL 506](#)

►► STRPOS(*source-string* , *search-string*) ►►

The STRPOS function is identical to the POSSTR function. For more information, see [“POSSTR or STRPOS scalar function”](#) on page 532.

STRRIGHT scalar function

The STRRIGHT function returns a string that consists of the specified number of rightmost bytes or specified string unit from a string.

[FL 506](#)

►► STRRIGHT — (*string-expression* , *integer*) ►►

The diagram shows the integer argument of the STRRIGHT function. A horizontal line extends from the comma to the closing parenthesis. Below this line, three brackets are stacked vertically, each pointing to the integer argument. The top bracket is labeled 'CODEUNITS16', the middle one 'CODEUNITS32', and the bottom one 'OCTETS'.

The STRRIGHT function is identical to the RIGHT function. For more information, see [“RIGHT scalar function”](#) on page 556.

SUBSTR scalar function

The SUBSTR function returns a substring of a string.

►► SUBSTR(*string-expression* , *start*) ►►

The diagram shows the arguments of the SUBSTR function. A horizontal line extends from the comma to the closing parenthesis. Below this line, two brackets are stacked vertically. The top one is labeled 'start' and the bottom one is labeled 'length'.

The schema is SYSIBM.

string-expression

An expression that specifies the string from which the result is derived. The string must be a character, graphic, or binary string. If *string-expression* is a character string, the result of the function is a character string. If it is a graphic string, the result of the function is a graphic string. If it is a binary string, the result of the function is a binary string.

The argument can also be a numeric data type. The numeric argument is implicitly cast to a VARCHAR data type.

A substring of *string-expression* is zero or more contiguous characters of *string-expression*. If *string-expression* is a graphic string, a character is a DBCS character. If *string-expression* is a character string or a binary string, a character is a byte. The SUBSTR function accepts mixed data strings. However, because SUBSTR operates on a strict byte-count basis, the result will not necessarily be a properly formed mixed data string.

start

An expression that specifies the position within *string-expression* to be the first character of the result. The value of the large integer must be between 1 and the length attribute of *string-expression*. (The length attribute of a varying-length string is its maximum length.) A value of 1 indicates that the first character of the substring is the first character of *string-expression*.

The argument can also be a character string or graphic string data type. The string input is implicitly cast to a numeric value of DECFLOAT(34) which is then assigned to an INTEGER value.

length

An expression that specifies the length of the resulting substring. If specified, *length* must be an expression that returns a value that is a built-in large integer data type.

The argument can also be a character string or graphic string data type. The string input is implicitly cast to a numeric value of DECFLOAT(34) which is then assigned to an INTEGER value.

The value must be greater than or equal to 0 and less than or equal to *n*, where *n* is the length attribute of *string-expression* - *start* + 1. The specified length must not, however, be the large integer constant 0.

If *length* is explicitly specified, *string-expression* is effectively padded on the right with the necessary number of characters so that the specified substring of *string-expression* always exists. Hexadecimal zeros are used as the padding character when *string-expression* is binary data. Otherwise, a blank is used as the padding character.

If *string-expression* is a fixed-length string, omission of *length* is an implicit specification of $\text{LENGTH}(\text{string-expression}) - \text{start} + 1$, which is the number of characters (or bytes) from the character (or byte) specified by *start* to the last character (or byte) of *string-expression*. If *string-expression* is a varying-length string, omission of *length* is an implicit specification of the greater of zero or $\text{LENGTH}(\text{string-expression}) - \text{start} + 1$. If the resulting length is zero, the result is an empty string.

If *length* is explicitly specified by a large integer constant that is 255 or less, and *string-expression* is not a LOB, the result is a fixed-length string with a length attribute of *length*. If *length* is not explicitly specified, but *string-expression* is a fixed-length string and *start* is an integer constant, the result is a fixed-length string with a length attribute equal to $\text{LENGTH}(\text{string-expression}) - \text{start} + 1$. In all other cases, the result is a varying-length string. If *length* is explicitly specified by a large integer constant, the length attribute of the result is *length*; otherwise, the length attribute of the result is the same as the length attribute of *string-expression*.

The result can be null; if any argument is null, the result is the null value.

The CCSID of the result is the CCSID of *string-expression*.

Example 1: FIRSTNME is a VARCHAR(12) column in sample table DSN8C10.EMP. When FIRSTNME has the value 'MAUDE':

Function:	Returns:
SUBSTR(FIRSTNME,2,3)	-- 'AUD'
SUBSTR(FIRSTNME,2)	-- 'AUDE'
SUBSTR(FIRSTNME,2,6)	-- 'AUDE' followed by two blanks
SUBSTR(FIRSTNME,6)	-- a zero-length string
SUBSTR(FIRSTNME,6,4)	-- four blanks

Example 2: Sample table DSN8C10.PROJ contains column PROJNAME, which is defined as VARCHAR(24). Select all rows from that table for which the string in PROJNAME begins with 'W L PROGRAM'.

```
SELECT * FROM DSN8C10.PROJ
WHERE SUBSTR(PROJNAME,1,12) = 'W L PROGRAM ';
```

Assume that the table has only the rows that were supplied by Db2. Then the predicate is true for just one row, for which PROJNAME has the value 'W L PROGRAM DESIGN'. The predicate is not true for the row in which PROJNAME has the value 'W L PROGRAMMING' because, in the predicate's string constant, 'PROGRAM' is followed by a blank.

Example 3: Assume that a LOB locator named *my_loc* represents a LOB value that has a length of 1 gigabyte. Assign the first 50 bytes of the LOB value to host variable *PORTION*.

```
SET :PORTION = SUBSTR(:my_loc,1,50);
```

Example 4: Assume that host variable *RESUME* has a CLOB data type and holds an employee's resume. This example shows some of the statements that find the section of department information in the resume and assign it to host variable *DeptBuf*. First, the POSSTR function is used to find the beginning and ending location of the department information. Within the resume, the department information starts with the string 'Department Information Section' and ends immediately before the string 'Education Section'. Then, using these beginning and ending positions, the SUBSTR function assigns the information to the host variable.

```
SET :DInfoBegPos = POSSTR(:RESUME, 'Department Information Section');
SET :DInfoEnPos = POSSTR(:RESUME, 'Education Section');
SET :DeptBuf = SUBSTR(:RESUME, :DInfoBegPos, :DInfoEnPos - :DInfoBegPos);
```

SUBSTRING scalar function

The SUBSTRING function returns a substring of a string.

Character:

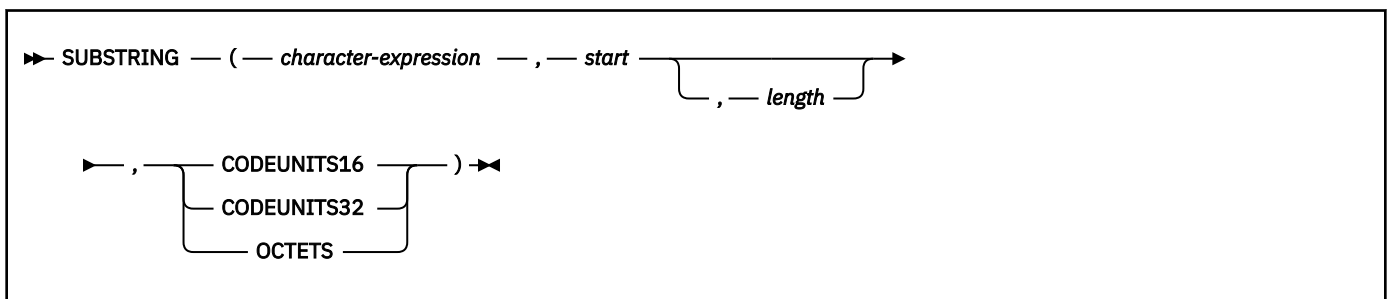

Graphic:

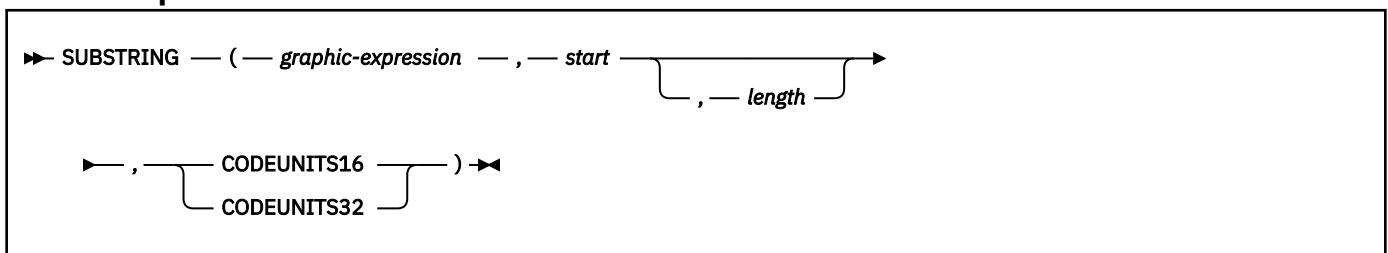

Binary:

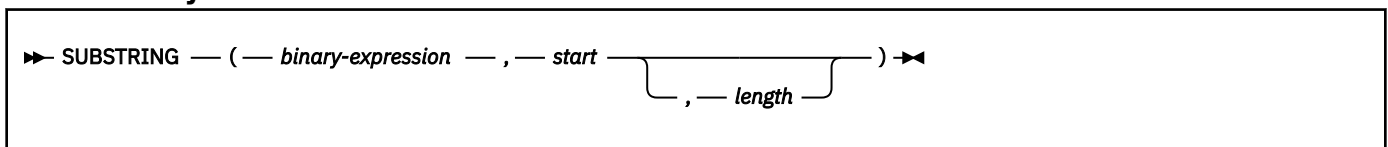

The schema is SYSIBM.

Character

character-expression

An expression that specifies the string from which the result is derived. The string must be a built-in character string.

The argument can also be a numeric data type. The numeric argument is implicitly cast to a VARCHAR data type.

The result of the function is a character string.

A substring of *character-expression* is zero or more contiguous units of *character-expression*. If CODEUNITS32 is specified, a unit is a Unicode UTF-32 character. If CODEUNITS16 is specified, a unit is a Unicode UTF-16 character. If OCTETS is specified, a unit is a byte.

start

An expression that specifies the position within the *character-expression* that is to be the first string unit of the result. *start* is expressed in the specified string unit, and must return an integer value.

The argument can also be another numeric value, a character string, or a graphic string data type. The input is implicitly cast to a numeric value of DECFLOAT(34) which is then assigned to an INTEGER value.

The value of *start* can be positive, negative, or zero. A value of 1 indicates that the first string unit of the result is the first string unit of *character-expression*.

length

An expression that specifies the maximum length of the resulting substring.

If *character-expression* is a fixed-length string, omission of *length* is an implicit specification of $\text{CHARACTER_LENGTH}(\text{character-expression}) - \text{start} + 1$, which is the number of string units (CODEUNITS16, CODEUNITS32, or OCTETS) from *start* to the last position of *character-expression*.

If *character-expression* is a varying length string, omission of *length* is an implicit specification of zero or $\text{CHARACTER_LENGTH}(\text{character-expression}) - \text{start} + 1$, whichever is greater. If the resulting length is zero, the result is an empty string.

If specified, *length* must be an expression that returns a value of an integer data type.

The argument can also be another numeric value, a character string, or a graphic string data type. The input is implicitly cast to a numeric value of DECFLOAT(34) which is then assigned to an INTEGER value.

The value must be greater than or equal to 0. If a value greater than *n* is specified, where *n* is the length attribute of *character-expression* - *start* + 1, then *n* is used as the length of the resulting substring. The value is expressed in the units that are explicitly specified.

For more information, see [Rigorous description of the actual length and result](#).

CODEUNITS16, CODEUNITS32, or OCTETS

Specifies the string unit that is used to express *start* and *length*. If *character-expression* is a character string that is defined as bit data, CODEUNITS16 and CODEUNITS32 cannot be specified.

CODEUNITS16

Specifies that *start* and *length* are expressed in terms of 16-bit UTF-16 code units.

CODEUNITS32

Specifies that *start* and *length* are expressed in terms of 32-bit UTF-32 code units.

OCTETS

Specifies that *start* and *length* are expressed in terms of bytes.

For more information about CODEUNITS16, CODEUNITS32, and OCTETS, see [“String unit specifications”](#) on page 106.

Graphic***graphic-expression***

An expression that specifies the string from which the result is derived. The string must be a built-in graphic string. The result of the function is a graphic string. A partial surrogate character in the expression is replaced with a blank.

A substring of *graphic-expression* is zero or more contiguous units of *graphic-expression*. If CODEUNITS32 is specified, a unit is a Unicode UTF-32 character. If CODEUNITS16 is specified, a unit is a Unicode UTF-16 character.

start

An expression that specifies the position within the *graphic-expression* that is to be the first string unit of the result. *start* is expressed in the specified string unit, and must return an integer value. The value of *start* can be positive, negative, or zero. A value of 1 indicates that the first string unit of the result is the first string unit of *graphic-expression*.

The argument can also be another numeric value, a character string, or a graphic string data type. The string input is implicitly cast to a numeric value of DECFLOAT(34) which is then assigned to an INTEGER value.

length

An expression that specifies the maximum length of the resulting substring.

If *graphic-expression* is a fixed-length string, omission of *length* is an implicit specification of $\text{CHARACTER_LENGTH}(\textit{graphic-expression}) - \textit{start} + 1$, which is the number of units (CODEUNITS16, CODEUNITS32) either explicitly or implicitly specified, from the start position to the last position of *graphic-expression*. If *graphic-expression* is a varying length string, omission of *length* is an implicit specification of zero or $\text{CHARACTER_LENGTH}(\textit{graphic-expression}) - \textit{start} + 1$, which is the number of units (CODEUNITS16, CODEUNITS32) either explicitly or implicitly specified, whichever is greater. If the resulting length is zero, the result is an empty string.

If specified, *length* must be an expression that returns a value of an integer data type.

The argument can also be another numeric value, a character string, or a graphic string data type. The string input is implicitly cast to a numeric value of DECFLOAT(34) which is then assigned to an INTEGER value.

The value must be greater than or equal to 0. If a value greater than *n* is specified, where *n* is the length attribute of $\textit{graphic-expression} - \textit{start} + 1$, then *n* is used as the length of the resulting substring. The value is expressed in the units that are explicitly specified.

For more information, see [Rigorous description of the actual length and result](#).

CODEUNITS16 or CODEUNITS32

Specifies the string unit that is used to express *start* and *length*.

CODEUNITS16

Specifies that *start* and *length* are expressed in terms of 16-bit UTF-16 code units.

CODEUNITS32

Specifies that *start* and *length* are expressed in terms of 32-bit UTF-32 code units.

For more information about CODEUNITS16 and CODEUNITS32, see [“String unit specifications” on page 106](#).

Binary

binary-expression

An expression that specifies the string from which the result is derived. The string must be a built-in binary string. The result of the function is a binary string.

A substring of *binary-expression* is zero or more contiguous units of *binary-expression*.

start

An expression that specifies the position within *binary-expression* to be the first byte of the result. It must be an integer value. *start* can be negative or zero. (The length attribute of a varying-length string is its maximum length.) A value of 1 indicates that the first byte of the substring is the byte unit of *binary-expression*.

length

An expression that specifies the length of the resulting substring.

If *binary-expression* is a fixed-length string, omission of *length* is an implicit specification of $\text{LENGTH}(\textit{binary-expression}) - \textit{start} + 1$ from the start position to the last position of *binary-expression*. If *binary-expression* is a varying length string, omission of *length* is an implicit specification of zero or $\text{CHARACTER_LENGTH}(\textit{binary-expression}) - \textit{start} + 1$, whichever is greater. If the resulting length is zero, the result is an empty string.

If specified, *length* must be a value of an integer data type. The value must be greater than or equal to 0. If a value greater than *n* is specified, where *n* is the length attribute of $\textit{binary-expression} - \textit{start} + 1$, then *n* is used as the length of the resulting substring.

For more information, see [Rigorous description of the actual length and result](#).

Rigorous description of the actual length and result

In this description, the term *character* means the “unit specified by string units” or “bytes” if the input is binary.

Let *C* be the value of the first argument, let *LC* be the length in characters of *C*, and let *S* be the value of the *start*.

- If *length* is specified, let *L* be the value of *length* and let *E* be *S+L*. Otherwise, let *E* be the larger of *LC + 1* and *S*.
- If either *C*, *S*, or *L* is the null value, the result of the function is the null value.
- If *E* is less than *S*, an exception condition is raised: data exception — substring error.
- Otherwise:
 - If *S* is greater than *LC* or if *E* is less than 1 (one), the result of the function is a zero-length string.
 - Otherwise:
 - Let *S1* be the larger of *S* and 1 (one). Let *E1* be the smaller of *E* and *LC+1*. Let *L1* be *E1-S1*.
 - The result of the function is a character string that contains the *L1* characters of *C* starting at character number *S1* in the same order that the characters appear in *C*.

The data type of the result depends on the data type of the first argument, as shown in the following table.

Table 89. Data type of the result of SUBSTRING

Data type of the first argument	Data type of the result
CHAR or VARCHAR	VARCHAR
CLOB	CLOB If <i>character-expression</i> is mixed data, the result is mixed data. Otherwise, the result is SBCS data.
GRAPHIC or VARGRAPHIC	VARGRAPHIC
DBCLOB	DBCLOB
BINARY or VARBINARY	VARBINARY
BLOB	BLOB

The length attribute of the result is equal to the length attribute of the first argument. If CODEUNITS16 or CODEUNITS32 is specified, see “Determining the length attribute of the final result” on page 108 for information about how to calculate the length attribute of the result string.

The result can be null; if any argument is null, the result is the null value.

If the first argument is character or graphic data, the CCSID of the result is the same as that of the first argument.

Example 1: C1 is a VARCHAR(12) column in table T1. One of its values is the string 'ABCDEFGH'. When C1 has the value 'ABCDEFGH':

Function:	Returns:
SUBSTRING(C1, -2, 2, OCTETS)	-- a zero-length string
SUBSTRING(C1, -2, 4, OCTETS)	'A'
SUBSTRING(C1, -2, OCTETS)	'ABCDEFGH'
SUBSTRING(C1, 0, 1, OCTETS)	-- a zero-length string

Example 2: FIRSTNAME is a VARCHAR(12) column in table T1. One of its values is the 6-character string 'Jürgen'. When FIRSTNAME has the value 'Jürgen':

Function:	Returns:
SUBSTRING(FIRSTNAME,1,2,CODEUNITS32)	'Jü' -- x'4AC3BC'
SUBSTRING(FIRSTNAME,1,2,CODEUNITS16)	'Jü' -- x'4AC3BC'
SUBSTRING(FIRSTNAME,1,2,OCTETS)	'J ' -- x'4A20' (a truncated string)
SUBSTRING(FIRSTNAME,8,CODEUNITS16)	-- a zero-length string
SUBSTRING(FIRSTNAME,8,4,OCTETS)	-- a zero-length string

TAN scalar function

The TAN function returns the tangent of the argument, where the argument is an angle, expressed in radians.

►► TAN(*numeric-expression*) ◄◄

The schema is SYSIBM.

The TAN and ATAN functions are inverse operations.

The argument must be an expression that returns the value of any built-in numeric data type that is not DECFLOAT. If the argument is not a double precision floating-point number, it is converted to one for processing by the function.

The result of the function is a double precision floating-point number.

The result can be null; if the argument is null, the result is the null value.

Example: Assume that host variable *TANGENT* is DECIMAL(2,1) with a value of 1.5. The following statement returns a double precision floating-point number with an approximate value of 14.10 .

```
SELECT TAN(:TANGENT)
FROM SYSIBM.SYSDUMMY1;
```

TANH scalar function

The TANH function returns the hyperbolic tangent of the argument, where the argument is an angle, expressed in radians.

►► TANH(*numeric-expression*) ◄◄

The schema is SYSIBM.

The TANH and ATANH functions are inverse operations.

The argument must be an expression that returns the value of any built-in numeric data type that is not DECFLOAT. If the argument is not a double precision floating-point number, it is converted to one for processing by the function.

The result of the function is a double precision floating-point number.

The result can be null; if the argument is null, the result is the null value.

Example: Assume that host variable *HTANGENT* is DECIMAL(2,1) with a value of 1.5. The following statement returns a double precision floating-point number with an approximate value of 0.90.

```
SELECT TANH(:HTANGENT)
FROM SYSIBM.SYSDUMMY1;
```

TIME scalar function

The TIME function returns a time that is derived from a value.

►► TIME(*expression*) ◄◄

The schema is SYSIBM.

The argument must be an expression that returns a value of one of the following built-in data types: a time, a timestamp, a character string, or a graphic string. If *expression* is a character or graphic string, it must not be a CLOB or DBCLOB, and its value must be a valid string representation of a time or timestamp with an actual length of not greater than 255 bytes. A time zone in a string representation of a timestamp is ignored. For the valid formats of string representations of times and timestamps, see [“String representations of datetime values” on page 120](#).

If *expression* is a TIMESTAMP WITH TIME ZONE value, *expression* is first cast to TIMESTAMP WITHOUT TIME ZONE, with the same precision as *expression*.

If *expression* is not a TIME value, *expression* is cast as follows:

- If *expression* is a TIMESTAMP WITH TIME ZONE value, *expression* is cast to TIMESTAMP WITHOUT TIME ZONE, with the same precision as *expression*.
- If *expression* is a string, *expression* is cast to TIME.

The result of the function is a time.

The result can be null; if the argument is null, the result is the null value.

The other rules depend on the data type of the argument:

If the argument is a time

the result is that time.

If the argument is a timestamp

the result is the time part of the timestamp.

If the argument is a string

the result is the time or time part of the timestamp represented by the string. If the CCSID of the string is not the same as the corresponding default CCSID at the server, the string is first converted to that CCSID.

The result CCSID is the appropriate CCSID of the argument encoding scheme and the result subtype is the appropriate subtype of the CCSID.

Example: Assume that a table named CLASSES contains one row for each scheduled class. Assume also that the class starting times are in the TIME column named STARTTM. Using these assumptions, select those rows in CLASSES that represent classes that start at 1:30 P.M.

```
SELECT *
FROM CLASSES
WHERE TIME(STARTTM) = '13:30:00';
```

TIMESTAMP scalar function

The TIMESTAMP function returns a TIMESTAMP WITHOUT TIME ZONE value from its argument or arguments.

►► TIMESTAMP(*expression-1* , *expression-2*) ◄◄

The schema is SYSIBM.

The rules for the arguments depend on whether the second argument is specified.

• **If only one argument is specified:**

The argument must be an expression that returns a value of one of the following built-in data types: a date, a timestamp, a character string, a graphic string, or a binary string. If *expression-1* is a character or graphic string, it must not be a CLOB or DBCLOB and it must have one of the following values:

- A valid string representation of a date or timestamp with an actual length that is not greater than 255 bytes. A time zone in a string representation of a timestamp is ignored. For the valid formats of string representations of timestamps, see [“String representations of datetime values”](#) on page 120.
- A character string or graphic string with an actual length of 8 that is assumed to be a IBM zSystems Store Clock value.
- A character string with an actual length of 13 that is assumed to be a result from the GENERATE_UNIQUE function.
- A character string or graphic string with an actual length of 14 that represents a valid date and time in the form *yyyxxddhmmss*, where *yyyy* is the year, *xx* is the month, *dd* is the day, *hh* is the hour, *mm* is the minute, and *ss* is the seconds.²⁰

If *expression-1* is a binary string, it must not be a BLOB and its value must be one of the following:

- A binary string with an actual length of 8 bytes that is assumed to be a IBM zSystems Store Clock value.
- A binary string with an actual length of 16 bytes that is assumed to be a IBM zSystems Store Clock extended value.
- A binary string with an actual length of 13 bytes that is assumed to be a result from the GENERATE_UNIQUE function.

• **If both arguments are specified:**

- If the data type of the second argument is not an integer:

The first argument must be an expression that returns a value of one of the following built-in data types: a date, a character string, or a graphic string. The second argument must be an expression that returns a value of one of the following built-in data types: a time, a character string, or a graphic string. A character string or graphic string must be a valid string representation of a time.

If *expression-1* is a character string or graphic string, it must not be a CLOB or DBCLOB, and its value must be a valid string representation of a date with an actual length that is not greater than 255 bytes. If *expression-2* is a character string or graphic string, it must not be a CLOB or DBCLOB, and its value must be a valid string representation of a time with an actual length that is not greater than 255 bytes. For the valid formats of string representations of dates and times, see [“String representations of datetime values”](#) on page 120.

- If the data type of the second argument is integer:

The first argument must be an expression that returns a value of one of the following built-in data types: a timestamp, a date, a character string, or a graphic string. The second argument must be an integer constant in the range 0 to 12 that represents the timestamp precision.

If *expression-1* is a character string or graphic string, it must not be a CLOB or DBCLOB, and its value must be a valid string representation of a timestamp or a date with an actual length that is not greater than 255 bytes.

If *expression-1* is a binary string, it must not be a BLOB, and its value must conform to the rules for when only one argument is specified. The second argument must be an integer constant in the range 0 to 12 that represents the timestamp precision.

The result of the function is a `TIMESTAMP WITHOUT TIME ZONE` value.

²⁰ A character or graphic string with an actual length of 14 that represents a valid date and time (as allowed for the `TIMESTAMP` function) is also allowed as input to other scalar functions that accept a timestamp as an input argument.

The timestamp precision and other rules depend on whether the second argument is specified:

If both arguments are specified and the second argument is not an integer:

The result is a `TIMESTAMP(6) WITHOUT TIME ZONE` value with the date that is specified by the first argument and the time that is specified by the second argument. The fractional seconds part of the timestamp is zero.

If both arguments are specified and the second argument is an integer:

The result is a `TIMESTAMP WITHOUT TIME ZONE` value with the precision that is specified in the second argument.

If only one argument is specified and it is a `TIMESTAMP(p) WITHOUT TIME ZONE`:

The result is that `TIMESTAMP(p) WITHOUT TIME ZONE` value.

If only one argument is specified and it is a `TIMESTAMP(p) WITH TIME ZONE`:

The result is the argument value, cast to `TIMESTAMP(p) WITHOUT TIME ZONE`. The value is the local timestamp, not UTC.

If only one argument is specified and it is a date:

The result is that date with an assumed time of midnight that is cast to `TIMESTAMP(0) WITHOUT TIME ZONE`.

If only one argument is specified and it is a character or graphic string:

The result is the `TIMESTAMP(6) WITHOUT TIME ZONE` value that is represented by that string extended with any missing time information. If the argument is a string of length 14, the `TIMESTAMP` has a fractional seconds part of zero. The string value must not contain a specification of time zone.

If only one argument is specified and it is a binary string:

The result is the `TIMESTAMP(6) WITHOUT TIME ZONE` value that is represented by that string. If the year value in the resulting timestamp is greater than 9999 an error is returned.

If the arguments include only date information, the time information in the result value is all zeros.

The result can be null; if any argument is null, the result is the null value.

If an argument is a string with a CCSID that is not the same as the corresponding default CCSID at the server, the string is first converted to that CCSID.

The result CCSID is the appropriate CCSID of the argument encoding scheme and the result subtype is the appropriate subtype of the CCSID. If both arguments are specified and their encoding schemes are different, the result CCSID is the appropriate CCSID of the application encoding scheme.

Notes

Specifying an LRSN as an argument:

When a 6-byte LRSN is used as the argument to the `TIMESTAMP` function, it must be left justified and padded on the right to a total length of 8 bytes. When a 10-byte LRSN is used, it must be left justified and padded on the right to a total length of 16 bytes.

Effect of leap seconds or the system time zone on the result of the `TIMESTAMP` function with a binary value as the first argument:

Db2 does not adjust for leap seconds or the system time zone when it converts an IBM zSystems Store Clock value or an IBM zSystems Store Clock extended value to a timestamp value.

Syntax alternatives:

If only one argument is specified, the `CAST` specification should be used for maximal portability. For more information, see [“CAST specification” on page 267](#).

`TIMESTAMP_TZ` is a similar function. For more information, see [“TIMESTAMP_TZ scalar function” on page 596](#).

Examples

Example: `TIMESTAMP` with a `DATE` column and a `TIME` column as arguments

Assume that table `TABLEX` contains a `DATE` column named `DATECOL` and a `TIME` column named `TIMECOL`. For some row in the table, assume that `DATECOL` represents 25 December 2008 and

TIMCOL represents 17 hours, 12 minutes, and 30 seconds after midnight. The following function returns the value '2008-12-25-17.12.30.000000'.

```
TIMESTAMP (DATECOL, TIMECOL)
```

Example: TIMESTAMP with a timestamp with time zone argument

Assume that host variable *PRSTSZ* contains '2008-02-29.20.00.000000 -08.30'. The following statement returns the value '2008-02-29.20.00.000000':

```
SELECT TIMESTAMP (:PRSTSZ)
FROM PROJECT;
```

Example: TIMESTAMP with a timestamp and an integer as arguments

The following invocation of the *TIMESTAMP* function converts a timestamp string with 7 digits of fractional seconds to a *TIMESTAMP(9) WITHOUT TIME ZONE* value and returns a value of '2007-09-24-15.53.37.216247400':

```
TIMESTAMP ('2007-09-24-15.53.37.2162474', 9);
```

TIMESTAMPADD scalar function

The *TIMESTAMPADD* function returns the result of adding the specified number of the designated interval to the timestamp value.

► *TIMESTAMPADD*(*interval*, *number*, *expression*) ◄

The schema is SYSIBM.

interval

An expression that returns a value of a built-in SMALLINT or INTEGER data type. The following values are valid values for *interval*:

Table 90. Valid values for intervals

Valid values for <i>interval</i>	equivalent intervals
1	Microseconds
2	Seconds
4	Minutes
8	Hours
16	Days
32	Weeks
64	Months
128	Quarters
256	Years

number

An expression that returns a value of a built-in SMALLINT or INTEGER data type.

expression

An expression that returns a value of a built-in *TIMESTAMP WITHOUT TIME ZONE* data type.

The result of the function is timestamp without time zone, with the same timestamp precision as *expression*.

The result can be null; if any argument is null, the result is the null value.

The result is determined using the normal rules for datetime arithmetic. See “Datetime arithmetic in SQL” on page 259. When the interval to add is expressed as weeks, the result is calculated as if *number* x 7 days had been specified. When the interval to add is expressed as quarters, the result is calculated as if *number* x 3 months had been specified.

Example 1: The following example will add 40 years to the specified timestamp. An interval of 256 designates years, while 40 specifies the number of intervals to add. The following statement returns the value '2005-07-27-15.30.00.000000'.

```
SELECT TIMESTAMPADD(256,40,TIMESTAMP('1965-07-27-15.30.00'))
FROM SYSIBM.SYSDUMMY1;
```

Example 2: The following example will add 18 months to the specified timestamp. An interval of 64 designates months, while 18 specifies the number of intervals to add. The following statement returns the value '2008-07-20-08.08.00.000000'.

```
SELECT TIMESTAMPADD(64,18,TIMESTAMP('2007-01-20-08.08.00'))
FROM SYSIBM.SYSDUMMY1;
```

Example 3: The following example will subtract 16 quarters (4 years) from the specified timestamp. An interval of 128 designates quarters, while -16 specifies the number of intervals to add (the '-' adds a negative amount). The following statement returns the value '2003-09-28-05.30.00.000000'.

```
SELECT TIMESTAMPADD(128,-16,TIMESTAMP('2007-09-28-05.30.00'))
FROM SYSIBM.SYSDUMMY1;
```

Example 4: The following example will add 18 weeks to the specified timestamp. An interval of 32 designates weeks, while 18 specifies the number of intervals to add. The following statement returns the value '2007-05-27-08.08.00.000000'.

```
SELECT TIMESTAMPADD(32,18,TIMESTAMP('2007-01-20-08.08.00'))
FROM SYSIBM.SYSDUMMY1;
```

TIMESTAMPDIFF scalar function

The TIMESTAMPDIFF function returns an estimated number of intervals of the type that is defined by the first argument, based on the difference between two timestamps.

►► TIMESTAMPDIFF(*numeric-expression* ,*string-expression*) ►◄

The schema is SYSIBM.

numeric-expression

An expression that returns a value that is a built-in SMALLINT or INTEGER data type. The value specifies the interval that is used to determine the difference between two timestamps. The following table lists the valid values for *numeric-expression*:

Table 91. Valid values for numeric-expression and equivalent intervals that are used to determine the difference between two timestamps

Valid values for <i>numeric-expression</i>	equivalent intervals
1	Microseconds
2	Seconds
4	Minutes
8	Hours
16	Days
32	Weeks

Table 91. Valid values for numeric-expression and equivalent intervals that are used to determine the difference between two timestamps (continued)

Valid values for numeric-expression	equivalent intervals
64	Months
128	Quarters
256	Years

string-expression

An expression that returns a value of a built-in character string or a graphic string data type that is not a LOB. The value is expected to be the result of subtracting two timestamps and converting the result to a character string of length 22. The string value must not have more than 6 digits to the right of a decimal point.

If the supplied argument is a graphic string, it is first converted to a character string before the function is executed.

The following table describes the elements of *string-expression*:

Table 92. *TIMESTAMPDIFF* String Elements

String elements	Valid values	Character position from the decimal point (negative is left)
Years	1-9998 or blank	-14 to -11
Months	0-11 or blank	-10 to -9
Days	0-30 or blank	-8 to -7
Hours	0-24 or blank	-6 to -5
Minutes	0-59 or blank	-4 to -3
Seconds	0-59	-2 to -1
Decimal separator	period	0
Microsecond	000000-999999	1 to 6

The result of the function is an integer with the same sign as the second argument.

The result can be null; if any argument is null, the result is the null value.

The returned value is determined for each interval as indicated by the following table:

Table 93. *TIMESTAMPDIFF* Computations

Result interval	Computation using duration elements
Years	years
Quarters	integer value of (months+(years*12))/3
Months	months + (years*12)
Weeks	integer value of ((days+(months*30))/7)+(years*52)
Days	days + (months*30)+(years*365)
Hours	hours+ ((days + (months*30)+(years*365))*24)
Minutes (the absolute value of the duration must not exceed 40850913020759.999999)	minutes + (hours+((days+(months*30)+(years*365))*24))*60
Seconds (the absolute value of the duration must be less than 680105031408.000000)	seconds + (minutes+(hours+((days+(months*30)+(years*365))*24))*60

Table 93. *TIMESTAMPDIFF* Computations (continued)

Result interval	Computation using duration elements
Microseconds (the absolute value of the duration must be less than 3547.483648)	microseconds + (seconds+(minutes*60))*1000000

The following assumptions are used in estimating a difference:

- One year has 365 days
- One year has 52 weeks
- One year has 12 months
- One month has 30 days
- One day has 24 hours
- One hour has 60 minutes
- One minute has 60 seconds

The use of these assumptions imply that some result values are an estimate of the interval. Consider the following examples:

- Difference of 1 month where the month has less than 30 days.

```
TIMESTAMPDIFF(16, CHAR(TIMESTAMP('1997-03-01-00.00.00')
- TIMESTAMP('1997-02-01-00.00.00')))
```

The result of the timestamp arithmetic is a duration of 00000100000000.000000, or 1 month. When the *TIMESTAMPDIFF* function is invoked with 16 for the interval argument (days), the assumption of 30 days in a month is applied and the result is 30.

- Difference of 1 day less than 1 month where the month has less than 30 days.

```
TIMESTAMPDIFF(16, CHAR(TIMESTAMP('1997-03-01-00.00.00')
- TIMESTAMP('1997-02-02-00.00.00')))
```

The result of the timestamp arithmetic is a duration of 00000027000000.000000, or 27 days. When the *TIMESTAMPDIFF* function is invoked with 16 for the interval argument (days), the result is 27.

- Difference of 1 day less than 1 month where the month has 31 days.

```
TIMESTAMPDIFF(64, CHAR(TIMESTAMP('1997-09-01-00.00.00')
- TIMESTAMP('1997-08-02-00.00.00')))
```

The result of the timestamp arithmetic is a duration of 00000030000000.000000, or 30 days. When the *TIMESTAMPDIFF* function is invoked with 64 for the interval argument (months), the result is 0. The days portion of the duration is 30, but it is ignored because the interval specified months.

Example: The following statement estimates the age of employees in months and returns that value as *AGE_IN_MONTHS*:

```
SELECT
  TIMESTAMPDIFF(64, CAST(CURRENT_TIMESTAMP-CAST(BIRTHDATE AS TIMESTAMP)
AS CHAR(22)))
  AS AGE_IN_MONTHS
FROM EMPLOYEE;
```

TIMESTAMP_FORMAT or TO_TIMESTAMP scalar function

The `TIMESTAMP_FORMAT` function returns a `TIMESTAMP WITHOUT TIME ZONE` value that is based on the interpretation of the input string using the specified format.

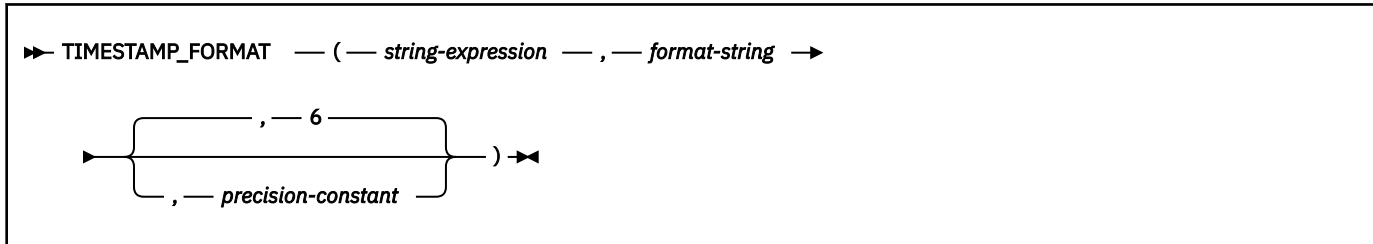

The schema is `SYSIBM`.

string-expression

An expression that returns a value of any built-in character or graphic string data type, other than a `CLOB` or `DBCLOB`, with an actual length that is not greater than 255 bytes. The *string-expression* must contain the components of a timestamp that correspond to the format that is specified in *format-string*, except for hour, minute, second, or fractional seconds.

format-string

An expression that returns a value that is a built-in character or graphic string data type, other than a `CLOB` or `DBCLOB`. The actual length must not be greater than 255 bytes. The value is a template for how *string-expression* is interpreted and then converted to a timestamp value.

A valid *format-string* must contain at least one format element, must not contain multiple specifications for any component of a timestamp, and can contain any combination of the format elements, unless otherwise noted in the following table. For example, *format-string* cannot contain both `YY` and `YYYY`, because both are used to interpret the year component of a *string-expression*. Two format elements can be separated by one or more of the following separator characters:

- minus sign (-)
- period (.)
- forward slash (/)
- comma (,)
- apostrophe (')
- semicolon (;)
- colon (:)
- blank ()

Separator characters can also be specified at the start or end of *format-string*. These separator characters can be used in any combination in the format string, for example `'YYYY/MM-DD HH:MM.SS'`. Separator character that is specified in a *string-expression* are used to separate components and are not required to match the separator character that is specified in the *format-string*.

Table 94. Format elements for the `TIMESTAMP_FORMAT` function

Format element	Related timestamp component	Description
AM or PM ¹	hour	Meridian indicator (morning or evening) without periods. This format element uses the exact strings "AM" or "PM".
A.M. or P.M. ¹	hour	Meridian indicator (morning or evening) with periods. This format element uses the exact strings "A.M." or "P.M."
D ¹	none	Day of the week (1-7).

Table 94. Format elements for the `TIMESTAMP_FORMAT` function (continued)

Format element	Related timestamp component	Description
DD	day	Day of the month (0-31).
DDD	month, day	Day of the year (001-366).
FF or FF n	fractional seconds	Fractional seconds (0-999999999999). The number n is used to specify the number of digits that is expected in the <i>string-expression</i> . Valid values for n are 1-12 with no leading zeros. Specifying FF is equivalent to specifying FF6. When the component in <i>string-expression</i> that corresponds to the FF format element is followed by a separator character or is the last component, the number of digits for the fractional seconds can be less than what is specified by the format element. In this case, zero digits are padded onto the right of the number of specified digits.
HH	hour	HH behaves the same as HH12.
HH12	hour	Hour of the day (01-12) in 12-hour format. AM is the default meridian indicator.
HH24	hour	Hour of the day (00-24) in 24-hour format.
J	year, month, and day	Julian day, the number of days since January 1, 4713 BC. (0000000-9999999)
MI	minute	Minute (00-59).
MM	month	Month (01-12).
MONTH, Month, or month ^{1, 2}	month	Name of the month in English.
MON, Mon, or mon ^{1, 2}	month	Abbreviated name of the month in English.
NNNNNN	microseconds	Microseconds, in the same format as FF6. (000000-999999).
RR	year	Last two digits of the adjusted year (00-99).
RRRR	year	RRRR behaves the same as YYYY.
SS	seconds	Seconds (00-59).
SSSSS	hours, minutes, and seconds	Seconds since the previous midnight (00000-86400).
Y	year	Last digit of the year (0-9). First three digits of the current year are used to determine the full 4-digit year.
YY	year	Last two digits of the year (00-99). First two digits of the current year are used to determine the full 4-digit year.
YYY	year	Last three digits of the year (000-999). First digit of the current year is used to determine the full 4-digit year.
YYYY	year	4-digit year (0000-9999).

Table 94. Format elements for the `TIMESTAMP_FORMAT` function (continued)

Format element	Related timestamp component	Description
----------------	-----------------------------	-------------

Notes:

1. This format element is case sensitive.
2. Only these exact spellings and case combinations can be used. If this format element is specified in an invalid case combination an error is returned.
3. The D format element does not contribute to any components of the resulting timestamp. However, a specified value for this format element must be correct for the combination of the day component of the resulting timestamp. For example, a value of '5' for *string-expression* is valid for a format string value of 'D'. However, value of '9' for *string-expression* would result in an error for the same *format-string*.

The RR format element can be used to change how a specification for a year is to be interpreted by adjusting the value to produce a 4-digit value depending on the last two digits of the current year according to the following table:

Table 95. Correspondence of adjusted year value and timestamp component

Digits of the current year	Two-digit year in <i>string-expression</i>	First two digits of the year component of timestamp
00-50	00-49	First two digits of the current year
51-99	00-49	First two digits of the current year + 1
00-50	50-99	First two digits of the current year -1
51-99	50-99	First two digits of the current year

For example, if the current year is 2007, '86' with format 'RR' means 1986, but if the current year is 2052, it means 2086.

The following defaults are used when a *format-string* does not include a format element for one of the following components of a timestamp:

Timestamp component	Default
year	current year, as 4 digits
month	current month. as 2 digits
day	01 (first day of the month)
hour	00
minute	00
second	00
fractional seconds	a number of zeros to match the timestamp precision of the result

If *string-expression* does not include a value that corresponds to an hour, minute, second, or fractional seconds format element that is specified in the *format-string*, the same defaults are used.

Leading zeros can be specified for any component of the timestamp value (that is, month, day, hour, minutes, seconds) that does not have the maximum number of significant digits for the corresponding format element in the *format-string*.

A substring of the *string-expression* that represents a component of a timestamp (such as year, month, day, hour, minutes, seconds) can include fewer than the maximum number of digits for that component of the timestamp that is indicated by the corresponding format element. Any missing digits default to zero. For example, with a format-string of 'YYYY-MM-DD HH24:MI:SS', an input value of '999-3-9 5:7:2' produces the same result as '0999-03-09 05:07:02'.

precision-constant

An integer constant that specifies the timestamp precision of the result. The value must be in the range 0 to 12. If *precision-constant* is not specified, the timestamp precision defaults to 6.

The result of the function is a `TIMESTAMP` with a precision that is based on *precision-constant*.

If either of the first two arguments can be null, the result can be null; if either of the first two arguments is null, the result is the null value.

The result `CCSID` is the appropriate `CCSID` of the encoding scheme of the first argument and the result subtype is the appropriate subtype of the `CCSID`.

Notes

Julian and Gregorian calendar:

The transition from the Julian calendar to the Gregorian calendar on 15 October 1582 is taken into account by this function.

Determinism:

`TIMESTAMP_FORMAT` is a deterministic function. However, the following invocations of the function depend on the value of the special register `CURRENT_TIMESTAMP`.

- *format-string* is not a constant
- *format-string* is a constant and includes format elements that are locale sensitive
- *format-string* is a constant and does not include a format element that fully defines the year (that is, J or YYYY). In this case the current year is used.
- *format-string* is a constant and does not include a format element that fully defines the month (for example, J, MM, MONTH, or MON). In this case the current month is used.

These invocations, which depend on the value of a special register, cannot be used wherever special registers cannot be used.

Using the 'D', 'Y', and 'y' format elements:

Db2 for z/OS does not support the 'DY', 'dy', and 'Dy' format elements that are supported by other platforms. If 'DY' or 'Dy' is specified in the format string, it is interpreted as the 'D' format element followed by the 'Y' or 'y' format element. This behavior might change in a future release. To ensure that a 'D' followed by 'Y' or 'y' is interpreted as two separate format elements, include a separator character after the 'D' format element.

Syntax alternatives:

`FL 506 TO_TIMESTAMP` is a synonym for `TIMESTAMP_FORMAT`.

`TO_DATE` is a synonym for `TIMESTAMP_FORMAT`.

Examples

Example 1:

Insert a row into the `IN_TRAY` table with a receiving timestamp that is equal to one second before the beginning of the year 2000 (December 31, 1999 at 23:59:59).

```
INSERT INTO IN_TRAY (RECEIVED)
VALUES (TIMESTAMP_FORMAT('1999-12-31 23:59:59', 'YYYY-MM-DD HH24:MI:SS'))
```

Example 2:

An application receives strings of date information into a variable called *INDATEVAR*. This value is not strictly formatted and might include two or four digits for years, and one or two digits for months and days. Date components might be separated with minus sign (-) or forward-slash (/) characters and are expected to be in day, month, and year order. Time information consists of hours (in 24-hour format) and minutes, and is usually separated by a colon. Sample values include '15/12/98 13:48' and '9-3-2004 8:02'. Insert such values into the IN_TRAY table.

```
INSERT INTO IN_TRAY (RECEIVED)
VALUES (TIMESTAMP_FORMAT(:INDATEVAR, 'DD/MM/RRRR HH24:MI'))
```

The use of 'RRRR' in the format allows for 2-digit and 4-digit year values and assigns the missing first two digits based on the current year. If 'YYYY' is used, input values with a 2-digit year will have leading zeros. The forward-slash separator also allows the minus sign character. Assuming a current year of 2007, resulting timestamp values from the sample values are as follows:

```
'15/12/98 13:48' --> 1998-12-15-13.48.00.000000
'9-3-2004 8:02' --> 2004-03-09-08.02.00.000000
```

TIMESTAMP_ISO scalar function

The `TIMESTAMP_ISO` function returns a timestamp value that is based on a date, a time, or a timestamp argument.

► `TIMESTAMP_ISO(expression)` ◄

The schema is SYSIBM.

If the argument is a date, `TIMESTAMP_ISO` inserts a value of zero for the time and the partial seconds parts of the timestamp. If the argument is a time, `TIMESTAMP_ISO` inserts the value of CURRENT DATE for the date part of the timestamp and a value of zero for the partial seconds part of the timestamp.

expression

An expression that returns a value of one of the following built-in data types:

- a `TIMESTAMP WITHOUT TIME ZONE`
- a date
- a time
- a character string
- or a graphic string

If *expression* is a character or graphic string, it must not be a CLOB or DBCLOB and its value must be a valid string representation of a date, a time, or a timestamp. For the valid formats of string representations of dates, times, and timestamps, see [“String representations of datetime values” on page 120](#).

If *expression* is a timestamp, the result of the function is timestamp without time zone, with the same precision as *expression*. Otherwise, the result of the function is a `TIMESTAMP (6) WITHOUT TIME ZONE`.

The result can be null; if the argument is null, the result is the null value.

Notes

Syntax alternatives:

Use the `CAST` specification for maximum portability. For more information, see [“CAST specification” on page 267](#).

Examples

Example 1:

Assume the following date value '1965-07-27'. The following statement returns the value '1965-07-27-00.00.00.000000'.

```
SELECT TIMESTAMP_ISO( DATE( '1965-07-27' ) )
FROM SYSIBM.SYSDUMMY1
```

TIMESTAMP_TZ scalar function

The `TIMESTAMP_TZ` function returns a `TIMESTAMP WITH TIME ZONE` value from the input arguments.

► `TIMESTAMP_TZ(expression-1 , expression-2)` ◄

The schema is `SYSIBM`.

expression-1

An expression that returns a value of one of the following built-in data types:

- a timestamp without time zone
- a timestamp with time zone
- a character string
- a graphic string

If *expression-1* is a character string or a graphic string, it must conform to the following rules:

- It must not be a CLOB or DBCLOB
- Its value must be a valid string representation of a timestamp without a time zone or a timestamp with a time zone value
- It must have an actual length that is not greater than 255 bytes

For the valid formats of string representations of datetime values, see [“String representations of datetime values”](#) on page 120.

If *expression-2* is specified, *expression-1* must be a timestamp without a time zone, or a string representation of a timestamp without a time zone.

expression-2

An expression that returns a character string or a graphic string.

If *expression-2* is a character string or graphic string, it must not be a CLOB or DBCLOB, and its value must be a valid string representation of a time zone in the format of `'±th:tm'` with values ranging from `-24:00` to `+24:00`, where *th* represents time zone hour and *tm* represents time zone minute.

The result of the function is equivalent to invoking the `CAST` specification, as indicated in the following table:

Table 96. `TIMESTAMP_TZ` function and equivalent `CAST` specification

TIMESTAMP_TZ function syntax	Equivalent CAST specification syntax
<code>TIMESTAMP_TZ(timestamp_wo_tz)</code>	<code>CAST(timestamp_wo_tz AS TIMESTAMP WITH TIME ZONE)</code>
<code>TIMESTAMP_TZ(timestamp_wo_tz, n)</code>	<code>CAST(timestamp_wo_tz AS TIMESTAMP(n) WITH TIME ZONE)</code>
<code>TIMESTAMP_TZ(timestamp_wo_tz, timezone)</code>	<code>CAST(CONCAT(VARCHAR(timestamp_wo_tz, timezone) AS TIMESTAMP WITH TIME ZONE)</code>

Table 96. *TIMESTAMP_TZ* function and equivalent *CAST* specification (continued)

TIMESTAMP_TZ function syntax	Equivalent CAST specification syntax
<code>TIMESTAMP_TZ(timestamp_wo_tz, timezone, n)</code>	<code>CAST(CONCAT(VARCHAR(timestamp_wo_tz, timezone) AS TIMESTAMP(n) WITH TIME ZONE)</code>
<code>TIMESTAMP_TZ(timestamp_w_tz)</code>	<code>CAST(timestamp_w_tz AS TIMESTAMP WITH TIME ZONE)</code>
<code>TIMESTAMP_TZ(timestamp_w_tz, n)</code>	<code>CAST(timestamp_w_tz AS TIMESTAMP(n) WITH TIME ZONE)</code>
<code>TIMESTAMP_TZ(timestamp_w_tz, timezone)</code>	N/A
<code>TIMESTAMP_TZ(timestamp_w_tz, timezone, n)</code>	N/A

timestamp_wo_tz

A timestamp without time zone value.

timestamp_w_tz

A timestamp with time zone value.

timezone

A time zone value.

n

The precision value.

When a string representation of a timestamp is a single-byte character set (SBCS) with a CCSID that is not the same as the default CCSID for SBCS data, that value is converted to the default CCSID for SBCS data before it is interpreted and converted to a timestamp value.

Notes

Syntax alternatives:

If only one argument is specified, the *CAST* specification should be used to ensure maximal portability. For more information, see [“CAST specification” on page 267](#)

FROM_TZ can be specified as a synonym for *TIMESTAMP_TZ* when *TIMESTAMP_TZ* specifies both *expression-1* and *expression-2*.

Examples

Example 1:

Assume that *TIMES* is a host variable with the value 2008-02-29-20.00.00.000000 and that *TZ* is a host variable with the value -3:00. Convert the value of *TIMES* and *TZ* to a timestamp with time zone.

```
SET :TIMESZ = TIMESTAMP_TZ(:TIMES, :TZ);
```

The host variable *TIMESZ* is set with the value that represents the timestamp with time zone as 2008-02-29-20.00.00.000000 -03:00.

TO_CHAR scalar function

The TO_CHAR function returns a character string representation of a timestamp value that has been formatted using a specified character template.

Character to VARCHAR

► TO_CHAR (— *character-expression* —) ◄

Timestamp to VARCHAR

► TO_CHAR (— *timestamp-expression* — , — *format-string* —) ◄

Decimal floating-point to VARCHAR

► TO_CHAR (— *decimal-floating-point-expression* — , — *format-string* —) ◄

The TO_CHAR scalar function is identical to the VARCHAR FORMAT scalar function. For more information, see [“VARCHAR_FORMAT scalar function”](#) on page 623.

TO_CLOB scalar function

The TO_CLOB function returns a CLOB representation of a string.

[FL 506](#)

Character to CLOB:

► TO_CLOB(*character-expression* , — *integer* —) ◄

CODEUNITS16
CODEUNITS32
OCTETS

Graphic to CLOB:

► TO_CLOB(*graphic-expression* , — *integer* —) ◄

CODEUNITS16
CODEUNITS32

The TO_CLOB function is identical to the CLOB function. For more information, see [“CLOB scalar function”](#) on page 415.

TO_DATE scalar function

The TO_DATE function returns a timestamp value that is based on the interpretation of the input string using the specified format.

```
►► TO_DATE ( string-expression , format-string , precision-constant ) ►►
```

The TO_DATE scalar function is identical to the TIMESTAMP_FORMAT scalar function. For more information, see [TIMESTAMP_FORMAT](#).

TO_NUMBER scalar function

The TO_NUMBER function returns a DECFLOAT(34) value that is based on the interpretation of the input string using the specified format.

```
►► TO_NUMBER ( string-expression , format-string ) ►►
```

The schema is SYSIBM.

The TO_NUMBER scalar function is identical to the DECFLOAT_FORMAT scalar function. For more information, see “[DECFLOAT_FORMAT scalar function](#)” on page 438.

TOTALORDER scalar function

The TOTALORDER function returns an ordering for DECFLOAT values. The TOTALORDER function returns a small integer value that indicates how *expression1* compares with *expression2*.

```
►► TOTALORDER( expression1,expression2 ) ►►
```

The schema is SYSIBM.

expression1

An expression that returns a built-in DECFLOAT value.

The argument can also be a character string or graphic string data type. The string input is implicitly cast to a numeric value of DECFLOAT(34).

expression2

An expression that returns a built-in DECFLOAT value.

The argument can also be a character string or graphic string data type. The string input is implicitly cast to a numeric value of DECFLOAT(34).

Numeric comparison is exact, and the result is determined for finite operands as if range and precision are unlimited. An overflow or underflow conditions cannot occur.

If one value is DECFLOAT(16) and the other is DECFLOAT(34), the DECFLOAT(16) value is converted to DECFLOAT(34) before the comparison is made.

TOTALORDER determines ordering based on the total order predicate rules of IEEE 754R, with the following result:

- -1 if the first argument is lower in order compared to the second.
- 0 if both arguments have the same order.

- 1 if the first argument is higher in order compared to the second.

The ordering of the special values and finite numbers is as follows:

```
-NAN<-SNAN<-INFINITY<-0.10<-0.100<-0<0<0.100<0.10<INFINITY<SNAN<NAN
```

The result of the function is a SMALLINT value.

The result can be null; if any argument is null, the result is the null value.

Examples: The following examples show the use of the TOTALORDER function to compare decimal floating point values:

```
TOTALORDER(-INFINITY, -INFINITY)           = 0
TOTALORDER(DECFLOAT(-1.0), DECFLOAT(-1.0))  = 0
TOTALORDER(DECFLOAT(-1.0), DECFLOAT(-1.00)) = -1
TOTALORDER(DECFLOAT(-1.0), DECFLOAT(-0.5))  = -1
TOTALORDER(DECFLOAT(-1.0), DECFLOAT(0.5))   = -1
TOTALORDER(DECFLOAT(-1.0), INFINITY)        = -1
TOTALORDER(DECFLOAT(-1.0), SNAN)            = -1
TOTALORDER(DECFLOAT(-1.0), NAN)             = -1
TOTALORDER(NAN, DECFLOAT(-1.0))             = 1
TOTALORDER(-NAN, -NAN)                      = 0
TOTALORDER(-SNAN, -SNAN)                    = 0
TOTALORDER(NAN, NAN)                        = 0
TOTALORDER(SNAN, SNAN)                      = 0
```

TO_TIMESTAMP scalar function

The TO_TIMESTAMP function returns a TIMESTAMP WITHOUT TIME ZONE value that is based on the interpretation of the input string using the specified format.

FL 506

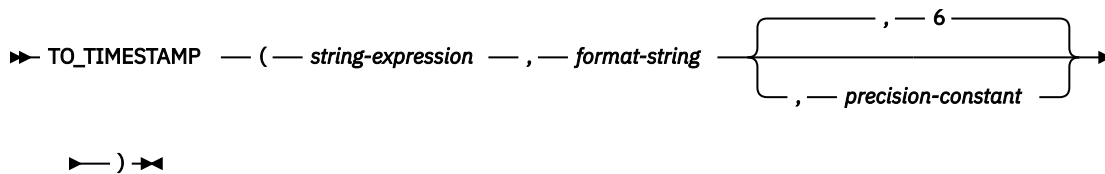

The TO_TIMESTAMP function is identical to the TIMESTAMP_FORMAT function. For more information, see [“TIMESTAMP_FORMAT or TO_TIMESTAMP scalar function”](#) on page 591.

TRANSLATE scalar function

The TRANSLATE function returns a value in which one or more characters of the first argument might have been converted to other characters.

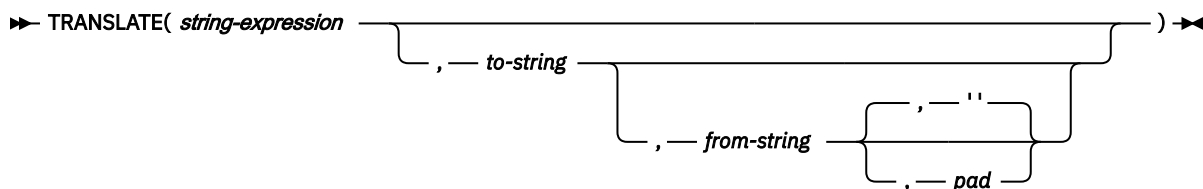

The schema is SYSIBM.

string-expression

An expression that specifies the string to be converted. *string-expression* must return a value that is a built-in character or graphic string data type that is not a LOB. If *string-expression* is an EBCDIC or

ASCII graphic string and *string-expression* is the only argument that is specified, the locale name that is specified by the CURRENT LOCALE LC_CTYPE special register must be a non-blank string.

The argument can also be a numeric data type. The numeric argument is implicitly cast to a VARCHAR data type.

to-string

An expression that specifies the characters to which certain characters in *string-expression* are to be converted. This string is sometimes called the *output translation table*. *to-string* must return a value that is a built-in character or graphic string data type that is not a LOB.

The argument can also be a numeric data type. The numeric argument is implicitly cast to a VARCHAR data type.

If the length of *to-string* is less than the length of *from-string*, *to-string* is padded to the length of *from-string* with the *pad* or a blank. If the length of *to-string* is greater than *from-string*, the extra characters in *to-string* are ignored without warning.

from-string

An expression that specifies the characters that if found in *string-expression* are to be converted. This string is sometimes called the *input translation table*. When a character in *from-string* is found, the character in *string-expression* is converted to the character in *to-string* that is in the corresponding position of the character in *from-string*.

from-string must return a value that is a built-in character or graphic string data type that is not a LOB.

The argument can also be a numeric data type. The numeric argument is implicitly cast to a VARCHAR data type.

If *from-string* contains duplicate characters, the first occurrence of the character is used, and no warning is issued. The default value for *from-string* is a string that starts with the character X'00' and ends with the character X'FF' (decimal 255).

pad

An expression that specifies the character with which to pad *to-string* if its length is less than *from-string*. *pad* is an expression that must return a value that is a built-in character or graphic string data type that is not a LOB and has a length of 1. A length of 1 is one single byte for character strings and one double byte string for graphic strings. The default is a blank that is appropriate for *string-expression*.

If *string-expression* is the only argument that is specified, the string is converted to uppercase based on the locale name that is specified by the CURRENT LOCALE LC_CTYPE special register, as follows:

blank

SBCS lowercase characters a-z are converted to SBCS uppercase characters A-Z, and characters with diacritical marks are not converted. If the string contains MIXED or DBCS characters, full-width lowercase characters a-z are converted to full-width Latin uppercase characters A-Z. For optimal performance, specify a blank string unless your data must be processed by using rules that are defined by a specific locale.

UNI

The conversion uses both the NORMAL and SPECIAL casing capabilities as described in [Select the conversions \(z/OS: Unicode Services User's Guide and Reference\)](#). You must not specify UNI when *string-expression* is EBCDIC data.

UNI_90

The conversion uses Unicode Standard 9.0.0 and the NORMAL casing capability, as described in [Select the conversions \(z/OS: Unicode Services User's Guide and Reference\)](#). You must not specify UNI_60 when *string-expression* is EBCDIC data.

UNI_90

The conversion uses Unicode Standard 6.0.0 and the NORMAL casing capability, as described in [Select the conversions \(z/OS: Unicode Services User's Guide and Reference\)](#). You must not specify UNI_90 when *string-expression* is EBCDIC data.

UNI_SIMPLE

Case conversions use the NORMAL casing capabilities as described in [Select the conversions \(z/OS: Unicode Services User's Guide and Reference\)](#). UNI_SIMPLE cannot be used with EBCDIC data.

locale name

The locale defines the rules for conversion to uppercase characters.

For Unicode data, usage of the TRANSLATE function (the TRANSLATE function with one argument is equivalent to the UPPER function) can result in expansion if certain characters are processed. You should ensure that the result string is large enough to contain the result of the expression.

If more than one argument is specified, the result string is built one piece at a time from *string-expression*. If *string-expression* is CHAR or VARCHAR, a piece is one byte long. If *string-expression* is GRAPHIC or VARGRAPHIC, a piece is two bytes long.

For each piece in *string-expression*, the *from-string* is searched for that same piece.

- If the piece in *string-expression* matches a piece in *from-string*, and there is a corresponding piece in *to-string*, that piece in *to-string* is moved to the result string. If the piece in *string-expression* matches a piece in *from-string*, but there is no corresponding piece in *to-string*, the *pad* is moved to the result string.
- If the piece in *string-expression* does not match any piece in *from-string*, the piece in *string-expression* is moved to the result string.

The string can contain mixed data. If only one argument is specified, the UPPER function is performed on the argument, and the rules for operating on mixed data in the UPPER function are observed. Full-width Latin lowercase a-z are converted to full-width Latin uppercase letters A-Z. If more than one argument is specified, the function operates as previously described for CHAR and VARCHAR data. The result is not necessarily a properly formed mixed data character string.

The encoding scheme of the result is the same as *string-expression*. The data type of the result of the function depends on the data type of *string-expression*, *to-string*, *from-string*, and *pad*:

- VARCHAR if *string-expression* is a character string. The CCSID of the result depends on the arguments:
 - If *string-expression*, *to-string*, *from-string*, or *pad* is bit data, the result is bit data.
 - If *string-expression*, *to-string*, *from-string*, and *pad* are all SBCS:
 - If *string-expression*, *to-string*, *from-string*, and *pad* are all SBCS Unicode data, the CCSID of the result is the CCSID for SBCS Unicode data.
 - If *string-expression* is SBCS Unicode data, and *to-string*, *from-string*, or *pad* are not SBCS Unicode data, the CCSID of the result is the mixed CCSID for Unicode data.
 - Otherwise, the CCSID of the result is the same as the CCSID of *string-expression*.
 - Otherwise, the CCSID of the result is the mixed CCSID that corresponds to the CCSID of *string-expression*. However, if the input is EBCDIC or ASCII and there is no corresponding system CCSID for mixed, the CCSID of the result is the CCSID of *string-expression*.
- VARGRAPHIC if *string-expression* is a graphic. The CCSID of the result is the same as the CCSID of *source-string*.

The result can be null; if the first argument is null, the result is the null value.

Examples

Example 1

Return the string 'abcdef' in uppercase characters. Assume that the locale in effect is blank.

```
SELECT TRANSLATE ('abcdef')
FROM SYSIBM.SYSDUMMY1
```

The result is the value 'ABCDEF'.

Example 2

Assume that host variable *SITE* has a data type of VARCHAR(30) and contains 'Hanauma Bay'.

```
SELECT TRANSLATE (:SITE)
FROM SYSIBM.SYSDUMMY1
```

Returns the value 'HANAUMA BAY'. The result is all uppercase characters because only one argument is specified.

```
SELECT TRANSLATE (:SITE, 'j', 'B')
FROM SYSIBM.SYSDUMMY1
```

Returns the value 'Hanauma jay'.

```
SELECT TRANSLATE (:SITE, 'ei', 'aa')
FROM SYSIBM.SYSDUMMY1
```

Returns the value 'Heneume Bey'.

```
SELECT TRANSLATE (:SITE, 'bA', 'Bay', '%')
FROM SYSIBM.SYSDUMMY1
```

Returns the value 'HAnAumA bA%'.

```
SELECT TRANSLATE (:SITE, 'r', 'Bu')
FROM SYSIBM.SYSDUMMY1
```

Returns the value 'Hana ma ray'.

Example 3

Assume that host variable *SITE* has a data type of VARCHAR(30) and contains 'Pivabiska Lake Place'.

```
SELECT TRANSLATE (:SITE, '$$', 'Ll')
FROM SYSIBM.SYSDUMMY1
```

Returns the value 'Pivabiska \$ake P\$ace'.

```
SELECT TRANSLATE (:SITE, 'pLA', 'Place', '.')
FROM SYSIBM.SYSDUMMY1
```

Returns the value 'pivAbiskA LAK. pLA..!'

Related concepts

[z/OS Unicode Services User's Guide and Reference](#)

TRIM scalar function

The TRIM function removes bytes from the beginning, from the end, or from both the beginning and end of a string expression.

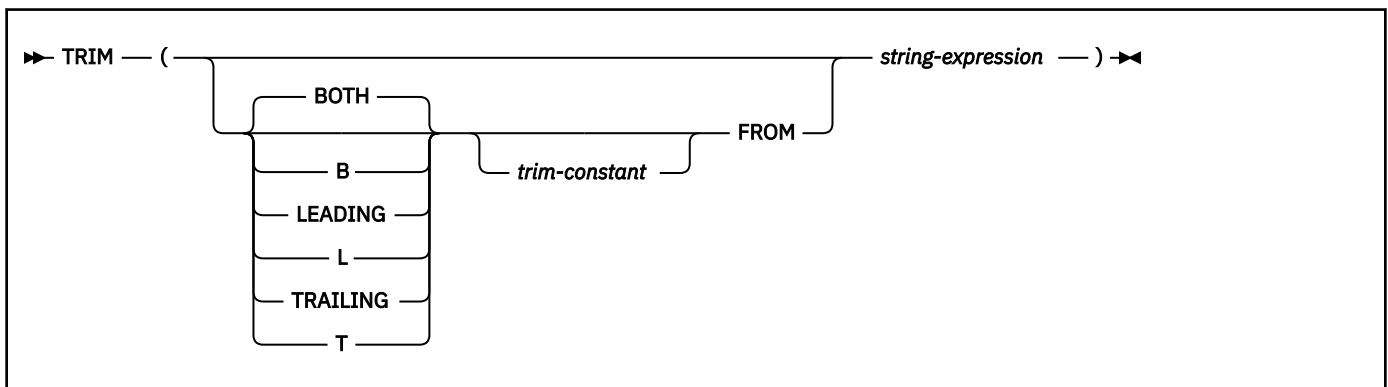

The schema is SYSIBM.

The first argument, if specified, indicates whether characters are removed from the end or the beginning of the string. If the first argument is not specified, the characters are removed from both the end and the beginning of the string.

trim-constant

Specifies a constant that indicates the binary, SBCS, or DBCS character that is to be removed. If *string-expression* is a character string, *trim-constant* must be an SBCS or DBCS single-character (2 bytes) constant. If *string-expression* is a binary string, *trim-constant* must be a single-byte binary string constant. If *string-expression* is a DBCS graphic or DBCS-only string, *trim-constant* must be a graphic constant that consists of a single DBCS character.

The default for *trim-constant* depends on the data type of *string-expression*:

- A DBCS blank if *string-expression* is a DBCS graphic string. For ASCII, the CCSID determines the hex value that represents a DBCS blank. For example, for Japanese (CCSID 301), X'8140' represents a DBCS blank, while for Simplified Chinese, X'A1A1' represents a DBCS blank. For EBCDIC, X'4040' represents a DBCS blank.
- A UTF-16 or UCS-2 blank (X'0020') if *string-expression* is a Unicode graphic string.
- A value of X'00' if *string-expression* is a binary string.
- Otherwise, a single byte blank. For EBCDIC, X'40' represents a blank. When not EBCDIC, X'20' represents a blank.

string-expression

An expression that returns a value that is a built-in character string data type, graphic data type, binary string data type, or numeric data type. *string-expression* must not be a LOB. If *string-expression* is numeric, it is cast to a character string before the function is evaluated. For more information about converting numeric to a character string, see [“VARCHAR scalar function” on page 615](#).

string-expression and *trim-expression* must have compatible data types.

The data type of the result depends on the data type of *string-expression*:

- If *string-expression* is a character string data type, the result is VARCHAR. If *string-expression* is defined as FOR BIT DATA the result is FOR BIT DATA.
- If *string-expression* is a graphic string data type, the result is VARGRAPHIC.
- If *string-expression* is a binary string data type, the result is VARBINARY.

The length attribute of the result is the same as the length attribute of *string-expression*. The actual length of the result is the length of *string-expression* minus the number of characters removed. If all of the characters are removed, the result is an empty string.

If *string-expression* can be null, the result can be null; if *string-expression* is null, the result is the null value.

The CCSID of the result is the same as that of *string-expression*.

Notes

Valid content for EBCDIC mixed string input:

If *string-expression* is an EBCDIC mixed string, the string must contain valid EBCDIC mixed data.

Examples

Example: Assume the host variable *HELLO* of type CHAR(9) has a value of ' Hello '.

```
SELECT TRIM(:HELLO), TRIM(TRAILING FROM :HELLO)
FROM SYSIBM.SYSDUMMY1
```

Results in 'Hello' and ' Hello' respectively.

Example: Assume the host variable *BALANCE* of type CHAR(9) has a value of '000345.50'.

```
SELECT TRIM(L '0' FROM :BALANCE)
FROM SYSIBM.SYSDUMMY1
```

Results in '345.50'

Related reference

[STRIP scalar function](#)

The STRIP function removes blanks or another specified character from the end, the beginning, or both ends of a string expression.

TRIM_ARRAY scalar function

The TRIM_ARRAY function deletes elements from the end of an ordinary array.

```
►► TRIM_ARRAY — (array-expression ,numeric-expression ) ◄◄
```

The schema is SYSIBM.

array-expression

An SQL variable, SQL parameter, or global variable of an ordinary array type, or a CAST specification of a parameter marker to an array type. An associative array type cannot be specified.

numeric-expression

Specifies the number of elements that are trimmed from the end of the array. *numeric-expression* can be any numeric data type with a value that can be cast to INTEGER. The value of *numeric-expression* must be greater than or equal to 0 and less than or equal to the cardinality of *array-expression*.

TRIM_ARRAY returns a value with the same array type as *array-expression*, with the cardinality reduced by the value of INTEGER(*numeric-expression*).

The result can be null; if any argument is null, the result is the null value.

The TRIM_ARRAY function can be invoked only in the following contexts:

- A source value for SET *assignment-statement* or SQL PL *assignment-statement*, or a VALUES INTO statement
- The value that is returned in a RETURN statement in an SQL scalar function

Notes

Syntax alternatives:

CAST (SQL-variable AS array-type) can be specified as an alternative to SQL-variable. CAST (SQL-parameter AS array-type) can be specified as an alternative to SQL-parameter.

ARRAY_TRIM is a synonym for the TRIM_ARRAY built in function.

Examples

Example 1:

Suppose that PHONENUMBERS is a user-defined array type that is defined as an ordinary array. RECENT_CALLS is an array variable of the PHONENUMBERS type. The following statement removes the last element from the array variable RECENT_CALLS.

```
SET RECENT_CALLS = TRIM_ARRAY(RECENT_CALLS,1);
```

Example 2:

Suppose that INTARRAY is a user-defined array type that is defined as an ordinary array with integer elements. SPECIALNUMBERS and LOWPRIMES are array variables of the INTARRAY type. The

SPECIALNUMBERS array contains the values of all the prime numbers less than 1000, which is 168 values. The following statement assigns the 10 smallest prime numbers in the SPECIALNUMBERS array to the first 10 elements of the LOWPRIMES array.

```
SET LOWPRIMES = TRIM_ARRAY(SPECIALNUMBERS,CARDINALITY(SPECIALNUMBERS)-10);
```

TRUNCATE or TRUNC scalar function

The TRUNCATE function returns the first argument, truncated as specified. Truncation is to the number of places to the right or left of the decimal point this is specified by the second argument.

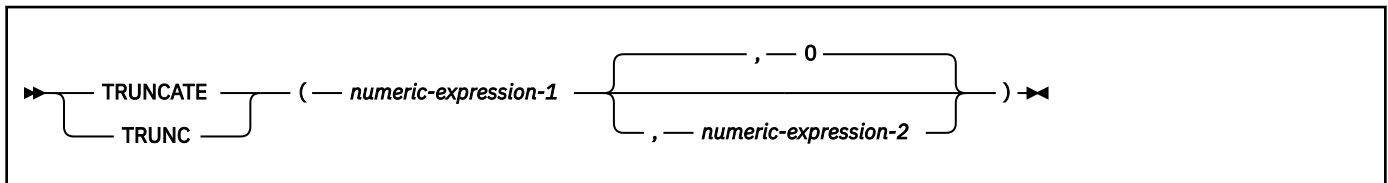

The schema is SYSIBM.

numeric-expression-1

An expression that returns a value of any built-in numeric data type.

If *expression-1* is a decimal floating-point data type, the DECFLOAT ROUNDING MODE will not be used. The rounding behavior of TRUNCATE corresponds to a value of ROUND_DOWN. If you want a different rounding behavior, use the QUANTIZE function.

The argument can also be a character string or graphic string data type. The string input is implicitly cast to a numeric value of DECFLOAT(34).

numeric-expression-2

An expression that returns a value that is a built-in SMALLINT or INTEGER data type. The absolute value of the integer specifies the number of places to truncate. The value of *numeric-expression-2* determines whether truncation is to the right or left of the decimal point.

If *numeric-expression-2* is not negative, *numeric-expression-1* is truncated to the absolute value of *numeric-expression-2* places to the right of the decimal point.

If *numeric-expression-2* is negative, *numeric-expression-1* is truncated to 1 + (the absolute value of *numeric-expression-2*) places to the left of the decimal point. If 1 + (the absolute value of *numeric-expression-2*) is greater than or equal to the number of digits to the left of the decimal point, the result is 0. For example, TRUNCATE(748.58, -4) returns 0.

The argument can also be a character string or graphic string data type. The string input is implicitly cast to a numeric value of DECFLOAT(34), which is then assigned to an INTEGER value.

The result of the function has the same data type and length attribute as the first argument.

The result can be null; if any argument is null, the result is the null value.

Example 1: Using sample employee table DSN8C10.EMP, calculate the average monthly salary for the highest paid employee. Truncate the result to two places to the right of the decimal point.

```
SELECT TRUNCATE(MAX(SALARY/12),2)
FROM DSN8C10.EMP;
```

Because the highest paid employee in the sample employee table earns \$52750.00 per year, the example returns the value 4395.83.

Example 2: Return the number 873.726 truncated to 2, 1, 0, -1, -2, -3, and -4 decimal places respectively.

```
SELECT TRUNC(873.726,2),
       TRUNC(873.726,1),
       TRUNC(873.726,0),
       TRUNC(873.726,-1),
       TRUNC(873.726,-2),
       TRUNC(873.726,-3),
```

```
TRUNC(873.726, -4)
FROM TABLEX
WHERE INTCOL = 1234;
```

This example returns the values 873.720, 873.700, 873.000, 870.000, 800.000, 0000.000, and 0000.000.

Example 3: Calculate both positive and negative numbers.

```
SELECT TRUNCATE( 3.5, 0),
       TRUNCATE( 3.1, 0),
       TRUNCATE(-3.1, 0),
       TRUNCATE(-3.5, 0)
FROM TABLEX;
```

This example returns: the values 3.0, 3.0, -3.0, -3.0.

TRUNC_TIMESTAMP scalar function

The TRUNC_TIMESTAMP function returns a TIMESTAMP WITHOUT TIME ZONE value that is the *expression*, truncated to the unit that is specified by the *format-string*. If *format-string* is not specified, *expression* is truncated to the nearest day, as if 'DD' was specified for *format-string*.

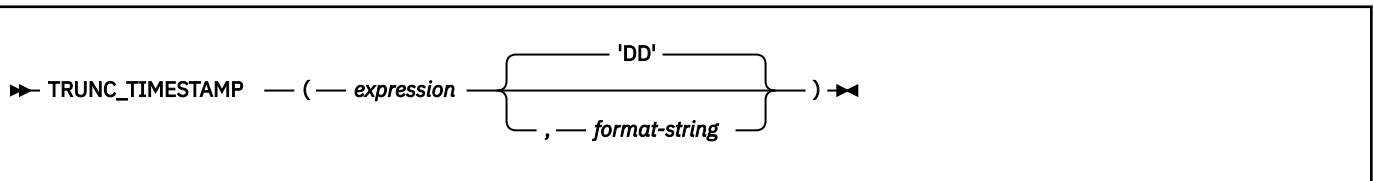

The schema is SYSIBM.

expression

An expression that returns a value of any of the following built-in data types: a timestamp, a character string, or a graphic string. If *expression* is a character or graphic string, it must not be a CLOB or DBCLOB, and its value must be a valid string representation of a timestamp with an actual length that is not greater than 255 bytes. A time zone in a string representation of a timestamp is ignored. For the valid formats of string representations of dates and timestamps, see [“String representations of datetime values”](#) on page 120.

format-string

An expression that returns a built-in character string or graphic string data type, with a length that is not greater than 255 bytes. *format-string* contains a template of how the timestamp represented by *expression* should be truncated. For example, if *format-string* is 'DD', the timestamp that is represented by *expression* is truncated to the nearest day. *format-string* must be a valid template for a timestamp, and not include leading or trailing blanks. Allowable values for *format-string* are listed in the following table.

Table 97. ROUND_TIMESTAMP and TRUNC_TIMESTAMP format models

Format model	Description of rounding or truncating for the format model	ROUND_TIMESTAMP example	TRUNC_TIMESTAMP example
CC	Century.	Input Value:	Input Value:
SCC	One greater than the first two digits of a four digit year.	1897-12-04-12.22.22.000000 Result: 1901-01-01-00.00.00.000000	1897-12-04-12.22.22.000000 Result: 1801-01-01-00.00.00.000000
	For ROUND_TIMESTAMP, rounds up on the 50th year of the century.		

Table 97. ROUND_TIMESTAMP and TRUNC_TIMESTAMP format models (continued)

Format model	Description of rounding or truncating for the format model	ROUND_TIMESTAMP example	TRUNC_TIMESTAMP example
SYYYY YYYYY YEAR SYEAR YYY YY Y	Year. For ROUND_TIMESTAMP, rounds up on July 1 to January 1st of the next year.	Input Value: 1897-12-04-12.22.22.000000 Result: 1898-01-01-00.00.00.000000	Input Value: 1897-12-04-12.22.22.000000 Result: 1897-01-01-00.00.00.000000
IYYYY IYY IY I	ISO year. For ROUND_TIMESTAMP, rounds up on July 1 to the first day of the next ISO year. The first day of the ISO year is defined as the Monday of the first ISO week.	Input Value: 1897-12-04-12.22.22.000000 Result: 1898-01-03-00.00.00.000000	Input Value: 1897-12-04-12.22.22.000000 Result: 1897-01-04-00.00.00.000000
Q	Quarter. For ROUND_TIMESTAMP, rounds up on the 16th day of the second month of the quarter.	Input Value: 1999-06-04-12.12.30.000000 Result: 1999-07-01-00.00.00.000000	Input Value: 1999-06-04-12.12.30.000000 Result: 1999-04-01-00.00.00.000000
MONTH MON MM RM	Month. For ROUND_TIMESTAMP, rounds up on the 16th day of the month.	Input Value: 1999-06-18-12.12.30.000000 Result: 1999-07-01-00.00.00.000000	Input Value: 1999-06-18-12.12.30.000000 Result: 1999-06-01-00.00.00.000000
WW	Same day of the week as the first day of the year. For ROUND_TIMESTAMP, rounds up on the 12th hour of the 4th day of the week, with respect to the first day of the year.	Input Value: 2000-05-05-12.12.30.000000 Result: 2000-05-06-00.00.00.000000	Input Value: 2000-05-05-12.12.30.000000 Result: 2000-04-29-00.00.00.000000

Table 97. ROUND_TIMESTAMP and TRUNC_TIMESTAMP format models (continued)

Format model	Description of rounding or truncating for the format model	ROUND_TIMESTAMP example	TRUNC_TIMESTAMP example
IW	Same day of the week as the first day of the ISO year. For ROUND_TIMESTAMP, rounds up on the 12th hour of the 4th day of the week, with respect to the first day of the ISO year.	Input Value: 2000-05-05-12.12.30.000000 Result: 2000-05-08-00.00.00.000000	Input Value: 2000-05-05-12.12.30.000000 Result: 2000-05-01-00.00.00.000000
W	Same day of the week as the first day of the month. For ROUND_TIMESTAMP, rounds up on the 12th hour of the 4th day of the week, with respect to the first day of the month.	Input Value: 2000-06-21-12.12.30.000000 Result: 2000-06-22-00.00.00.000000	Input Value: 2000-06-21-12.12.30.000000 Result: 2000-06-15-00.00.00.000000
DDD DD J	Day. For ROUND_TIMESTAMP, rounds up on the 12th hour of the day.	Input Value: 2000-05-17-12.59.59.000000 Result: 2000-05-18-00.00.00.000000	Input Value: 2000-05-17-12.59.59.000000 Result: 2000-05-17-00.00.00.000000
DAY DY D	Starting day of the week. For ROUND_TIMESTAMP, rounds up with respect to the 12th hour of the 4th day of the week. The first day of the week is always Sunday.	Input Value: 2000-05-17-12.59.59.000000 Result: 2000-05-21-00.00.00.000000	Input Value: 2000-05-17-12.59.59.000000 Result: 2000-05-14-00.00.00.000000
HH HH12 HH24	Hour. For ROUND_TIMESTAMP, rounds up at 30 minutes.	Input Value: 2000-05-17-23.59.59.000000 Result: 2000-05-18-00.00.00.000000	Input Value: 2000-05-17-23.59.59.000000 Result: 2000-05-17-23.00.00.000000
MI	Minute. For ROUND_TIMESTAMP, rounds up at 30 seconds.	Input Value: 2000-05-17-23.58.45.000000 Result: 2000-05-17-23.59.00.000000	Input Value: 2000-05-17-23.58.45.000000 Result: 2000-05-17-23.58.00.000000

Table 97. ROUND_TIMESTAMP and TRUNC_TIMESTAMP format models (continued)

Format model	Description of rounding or truncating for the format model	ROUND_TIMESTAMP example	TRUNC_TIMESTAMP example
SS	Second. For ROUND_TIMESTAMP, rounds up at 500000 microseconds.	Input Value: 2000-05-17-23.58.45.500000 Result: 2000-05-17-23.58.46.000000	Input Value: 2000-05-17-23.58.45.500000 Result: 2000-05-17-23.58.45.000000

expression is cast as follows:

- If *expression* is a timestamp with time zone value, *expression* is cast to a timestamp without time zone value, with the same precision as *expression*.
- Otherwise, *expression* is cast to `TIMESTAMP(6) WITHOUT TIME ZONE`.

The result of the function is a timestamp with time zone.

The result can be null; if any argument is null, the result is the null value.

The result CCSID is the appropriate CCSID of the argument encoding scheme and the result subtype is the appropriate subtype of the CCSID.

Example: Set the host variable `TRNK_TMSTMP` with the specified date rounded to the nearest year value.

```
SET :TRNK_TMSTMP = TRUNC_TIMESTAMP('2008-03-14-17.30.00', 'YEAR');
```

The host variable `TRNK_TMSTMP` is set with the value '2008-01-01-00.00.00.000000'.

UCASE scalar function

The UCASE function returns a string in which all the characters have been converted to uppercase characters, based on the CCSID of the argument.

```
UCASE(string-expression [, locale-name-string] [, integer])
```

The UCASE function is identical to the UPPER function. For more information, see [“UPPER scalar function”](#) on page 612.

UNICODE scalar function

The UNICODE function returns the Unicode UTF-16 code value of the leftmost character of the argument as an integer.

```
UNICODE(string-expression)
```

The schema is SYSIBM.

string-expression can be of any built-in string data type that is not a LOB.

The argument can also be a numeric data type. The numeric argument is implicitly cast to a VARCHAR data type.

If the argument is ASCII, EBCDIC, or Unicode UTF-8, it is first converted to a Unicode UTF-16 string (CCSID 1200) before the function is executed.

The result of the function is an INTEGER.

The result can be null; if the argument is null, the result is the null value.

Example: The following example returns the Unicode value of 峰 as an integer and assigns the value to the host variable *hv*:

```
Set :hv = UNICODE('峰');
```

hv is set to an integer with a value '23792'.

UNICODE_STR or UNISTR scalar function

The UNICODE_STR function returns a string in Unicode UTF-8 or UTF-16, depending on the specified option. The string represents a Unicode encoding of the input string.

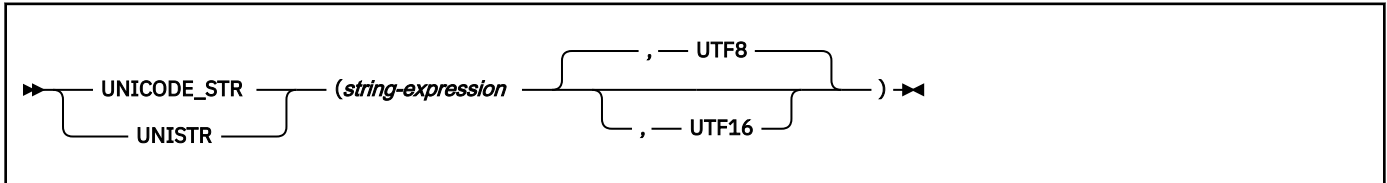

The schema is SYSIBM.

string-expression

An expression that returns a value of a built-in character or graphic string. A character string must not be bit data. Values that are preceded by a backslash ('\') are treated as Unicode UTF-16 characters (for example '\0041' is the Unicode UTF-16 representation for 'A'). A double backslash '\\' indicates a backslash in the string. A partial surrogate character in the expression is replaced with a blank.

The argument can also be a numeric data type. The numeric argument is implicitly cast to a VARCHAR data type.

UTF8 or UTF16

Specifies the Unicode encoding of the result. If UTF8 is specified, the result is returned as a Unicode UTF-8 character string. If UTF16 is specified, the result is returned as a Unicode UTF-16 graphic string. UTF8 is the default.

The result of the function depends on the second argument:

- VARCHAR if UTF8 is specified
- VARGRAPHIC if UTF16 is specified

The length attribute of the result depends on the second argument (UTF8 or UTF16). The length attribute of the result is calculated using the formulas in [Table 37 on page 163](#). If the result is a character string, the length attribute of the result is $\text{MIN}(n, 32704)$. If the result is a graphic string, the length attribute of the result is $\text{MIN}(n, 16352)$. Where n is the result of applying the formulas in [Table 37 on page 163](#) based on input and output data types.

If the actual length of the result string exceeds the maximum for the return type, an error occurs.

The result can be null; if the argument is null, the result is the null value.

Examples

Example 1:

The following example sets the host variable *HV1* to a VARCHAR value that represents the Unicode UTF-8 string that corresponds to the argument:

```
SET :HV1 = UNICODE_STR('Hi, my name is \5CF0');
```

HV1 is assigned a Unicode UTF-8 string with the following value 'Hi, my name is 峰'

UPPER scalar function

The UPPER function returns a string in which all the characters have been converted to uppercase characters.

```
UPPER( string-expression , — locale-name-string , — integer )
```

The schema is SYSIBM.

string-expression

An expression that specifies the string to be converted. *string-expression* must return a value that is a built-in character or graphic string. A character string argument must not be a CLOB, and a graphic string argument must not be a DBCLOB. If *string-expression* is an EBCDIC graphic string, a blank string must not be specified for *locale-name-string*. If *string-expression* is bit data, *locale-name-string* must not be specified.

locale-name-string

A string constant or a string host variable other than a CLOB or DBCLOB that specifies a valid locale name. If *locale-name-string* is not in EBCDIC, it is converted to EBCDIC. The length of *locale-name-string* must be in the range 1–255 bytes of the EBCDIC representation. The value of *locale-name-string* is not case sensitive and must be a valid locale. For information about locales and their naming conventions, see [Locale naming conventions \(XL C/C++ Programming Guide\)](#). Some examples of locales include:

```
Fr_BE  
Fr_FR@EURO  
En_US  
Ja_JP
```

The conversion process is determined by the value that is specified for the locale name, as follows:

blank

SBCS lowercase characters a-z are converted to SBCS uppercase characters A-Z, and characters with diacritical marks are not converted. If the string contains MIXED or DBCS characters, full-width lowercase characters a-z are converted to full-width Latin uppercase characters A-Z. For optimal performance, specify a blank string unless your data must be processed by using the rules that are defined by a specific locale.

UNI

The conversion uses both the NORMAL and SPECIAL casing capabilities as described in [Select the conversions \(z/OS: Unicode Services User's Guide and Reference\)](#). You must not specify UNI when *string-expression* is EBCDIC data.

UNI_60

The conversion uses Unicode Standard 6.0.0 and the NORMAL casing capability, as described in [Select the conversions \(z/OS: Unicode Services User's Guide and Reference\)](#). You must not specify UNI_60 when *string-expression* is EBCDIC data.

UNI_90

The conversion uses Unicode Standard 9.0.0 and the NORMAL casing capability, as described in [Select the conversions \(z/OS: Unicode Services User's Guide and Reference\)](#). You must not specify UNI_90 when *string-expression* is EBCDIC data.

UNI_SIMPLE

Case conversions use the NORMAL casing capabilities as described in [Select the conversions \(z/OS: Unicode Services User's Guide and Reference\)](#). UNI_SIMPLE cannot be used with EBCDIC data.

locale name

The locale defines the rules for conversion to uppercase characters.

The value of the host variable must not be null. If the host variable has an associated indicator variable, the value of the indicator variable must not indicate a null value. The locale name must be:

- left justified within the host variable
- padded on the right with blanks if its length is less than that of the host variable and the host variable is in fixed length CHAR or GRAPHIC data type

If *locale-name-string* is not specified, the locale is determined by special register CURRENT LOCALE LC_CTYPE. For information about the special register, see [“CURRENT LOCALE LC_CTYPE special register”](#) on page 196.

If the UPPER function is referenced in an expression-based index, *locale-name-string* must be specified

integer

An integer value that specifies the length attribute of the result. If specified, *integer* must be an integer constant in the range 1–32704 bytes in the representation of the encoding scheme of *string-expression*.

If *integer* is not specified, the length attribute of the result is the same as the length of *string-expression*.

For Unicode data, usage of the UPPER function can result in expansion if certain characters are processed. For example, UPPER(UX'FB03') will result in UX'004600460049'. You should ensure that the result string is large enough to contain the result of the expression.

The result can be null; if the argument is null, the result is the null value.

Notes

Syntax alternatives:

UCASE is a synonym for UPPER. UPPER should be used for conformance to the SQL standard.

Examples

Example 1:

Return the string 'abcdef' in uppercase characters. Assume that the locale in effect is blank.

```
SELECT UPPER('abcdef')
FROM SYSIBM.SYSDUMMY1
```

The result is the value 'ABCDEF'.

Example 2:

Return the string 'ffi' in the uppercase characters ('FFI'). Assume that the locale in effect is "UNI".

```
SELECT UPPER(UX'FB03')
FROM SYSIBM.SYSDUMMYU;
```

This would result in an error because of the expansion that occurs when certain Unicode characters are processed. To avoid the error, you would need to use the following statement instead:

```
SELECT UPPER(CAST(UX'FB03' AS VARCHAR(3)))
FROM SYSIBM.SYSDUMMYU;
```

The result of the preceding statement is the value 'FFI'.

Example 3:

Create an index EMPLOYEE_NAME_UPPER for table EMPLOYEE based on built-in function UPPER with locale name 'Fr_FR@EURO'.

```
CREATE INDEX EMPLOYEE_NAME_UPPER
ON EMPLOYEE (UPPER(LASTNAME, 'Fr_FR@EURO', 60),
             UPPER(FIRSTNAME, 'Fr_FR@EURO', 60),
             ID);
```

The result is the value 'ABCDEF'.

Related concepts

[z/OS Unicode Services User's Guide and Reference](#)

Related reference

[z/OS XL C/C++ Programming Guide](#)

VALUE scalar function

The VALUE function returns the value of the first non-null expression.

The diagram shows the syntax for the VALUE function: VALUE (expression, expression). The first expression is underlined, and a curved arrow points from the second expression back to the first, indicating that the function returns the value of the first non-null expression.

The schema is SYSIBM.

The VALUE function is identical to the COALESCE function. COALESCE should be used for conformance to SQL standard. For more information, see [“COALESCE scalar function”](#) on page 417.

VARBINARY scalar function

The VARBINARY function returns a VARBINARY (varying-length binary string) representation of a string of any type.

The diagram shows the syntax for the VARBINARY function: VARBINARY(string-expression, integer). The string-expression and integer are underlined, and a bracket groups them as arguments to the function.

The schema is SYSIBM.

string-expression

An expression that returns a value that is a built-in character string, graphic string, binary string, or a row ID type.

integer

An integer value that specifies the length attribute of the resulting binary string. The value must be an integer in the range 1–32704 inclusive. If integer is not specified:

- If the *string-expression* is the empty string constant, the length attribute of the result is 1.
- Otherwise, the length attribute of the result is the same as the length attribute of the *string-expression*, unless the *string-expression* is a graphic string. In this case, the length attribute of the result is twice the length attribute of the *string-expression*.

The result of the function is a varying-length binary string.

The result can be null; if the first argument is null, the result is the null value.

The actual length of the result is the minimum of the length attribute of the result and the actual length of the *string-expression* (or twice the length of the *string-expression* if *string-expression* returns a graphic string). If the length of the *string-expression* is greater than the length attribute of the result, truncation is performed, and a warning is returned unless the *string-expression* is a character string and all the truncated characters are blanks, or the *string-expression* is a graphic string and all the truncated characters are double-byte blanks.

Example 1: The following function returns a varying-length binary string with a length attribute 1, actual length 0, and a value of empty string:

```
SELECT VARBINARY(' ')
FROM SYSIBM.SYSDUMMY1;
```

Example 2: The following function returns a varying-length binary string with a length attribute 5, actual length 3, and a value BX'D2C2C8':

```
SELECT VARBINARY('KBH',5)
FROM SYSIBM.SYSDUMMY1;
```

Example 3: The following function returns a varying-length binary string with a length attribute 3, actual length 3, and a value BX'D2C2C8'

```
SELECT VARBINARY('KBH',3)
FROM SYSIBM.SYSDUMMY1;
```

Example 4: The following function returns a varying-length binary string with a length attribute 3, actual length 3, and a value BX'D2C2C8', a warning is also returned.

```
SELECT VARBINARY('KBH-93',3)
FROM SYSIBM.SYSDUMMY1;
```

Example 5: The following function returns a varying-length binary string with a length attribute 3, actual length 3, and a value BX'C1C2C3', a warning is also returned.

```
SELECT VARBINARY(BINARY('ABC',5),3)
FROM SYSIBM.SYSDUMMY1;
```

VARCHAR scalar function

The VARCHAR function returns a varying-length character string representation of the value specified by the first argument.

The syntax of the VARCHAR function depends on the data type of the input argument. The following types of input arguments are accepted.

Integer to Varchar:

```
►► VARCHAR( integer-expression ) ►►
```

Decimal to Varchar:

```
►► VARCHAR( decimal-expression , decimal-character ) ►►
```

Floating-point to Varchar:

```
►► VARCHAR( floating-point-expression ) ►►
```

Decimal floating point to Varchar:

```
►► VARCHAR( decimal-floating-point-expression ) ►►
```

Character to Varchar:

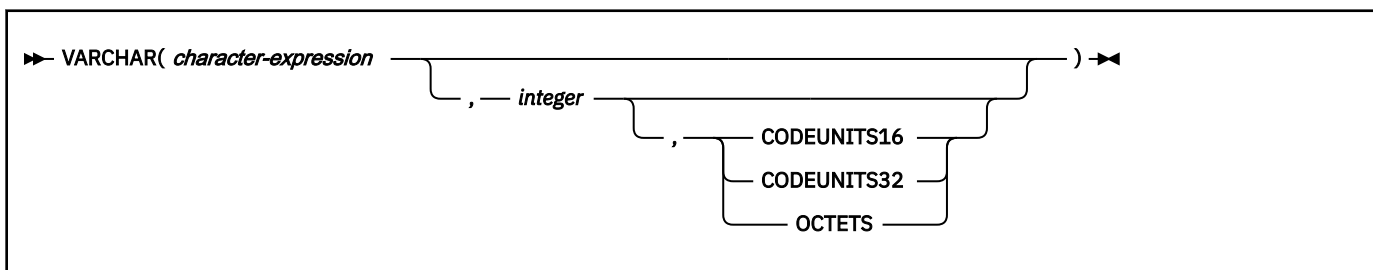

Graphic to Varchar:

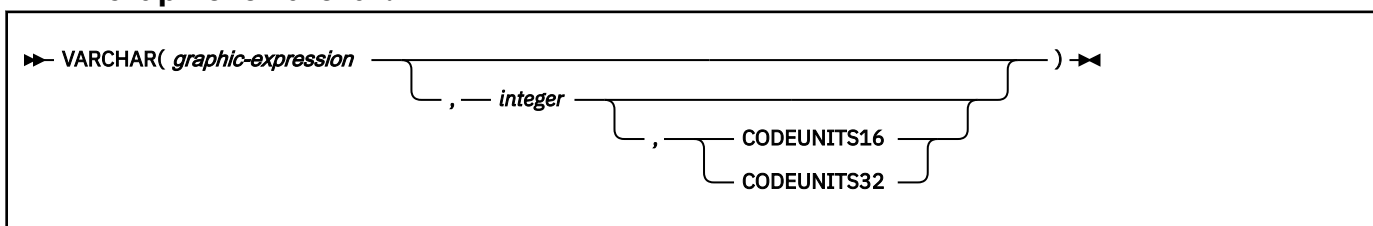

Datetime to Varchar:

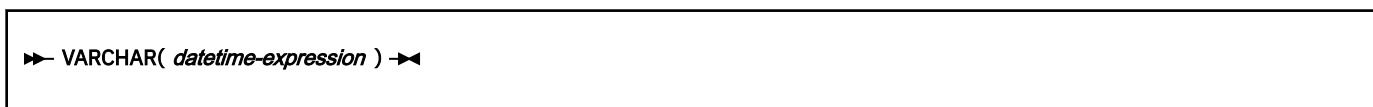

Row ID to Varchar:

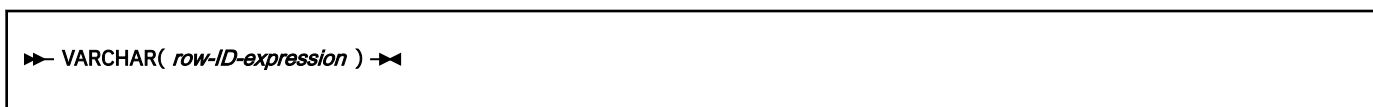

The schema is SYSIBM.

The VARCHAR function returns a varying-length character string representation of one of the following values:

- An integer number if the first argument is a SMALLINT, INTEGER, or BIGINT
- A decimal number if the first argument is a decimal number
- A double-precision floating-point number if the first argument is a DOUBLE or REAL
- A decimal floating-point number if the first argument is a DECFLOAT
- A character string value if the first argument is any type of character string
- A graphic string if the first argument is an EBCDIC or Unicode graphic string
- A datetime value if the first argument is a date, time, or timestamp
- A row ID value if the first argument is a row ID

The result of the function is a varying-length character string (VARCHAR).

The result can be null; if the first argument is null, the result is the null value.

Integer to Varchar

integer-expression

An expression that returns a value that is a built-in integer data type (SMALLINT, INTEGER, BIGINT).

The result is a varying-length character string representation of the argument in the form of an SQL integer constant. The actual length of the result is the smallest number of characters that can be used to represent the value of the argument. The result consists of n characters that are the

significant digits that represent the value of the argument with a preceding minus sign if the argument is negative. A positive value starts with a digit. Leading zeroes are not included.

- If the argument is a small integer, the length attribute of the result is 6.
- If the argument is a large integer, the length attribute of the result is 11.
- If the argument is a big integer, the length attribute of the result is 20.

The CCSID of the result is determined from the application encoding scheme.

Decimal to Varchar

decimal-expression

An expression that returns a value that is a built-in decimal data type. To specify a different precision and scale for the expression's value, apply the DECIMAL function to the expression before applying the VARCHAR function.

decimal-character

Specifies the single-byte character constant that is used to delimit the decimal digits in the result character string. The character must not be a digit, a plus sign (+), a minus sign (-), or a blank. The default is the period (.) or comma (,). For information on what factors govern the choice, see [“Decimal point representation” on page 323](#).

The result is a varying-length character string representation of the first argument. The actual length of the result is the smallest number of characters that can be used to represent the result, except that trailing zeros are included. The result includes a decimal character and up to p digits where p is the precision of *decimal-expression* with a preceding minus sign if the argument is negative. A positive value starts with a digit or the *decimal-character*. Leading zeros are not returned. If the scale of decimal expression is zero, the decimal character is not returned.

The length attribute of the result is $2+p$ where p is the precision of *decimal-expression*.

21

The CCSID of the result is determined from the application encoding scheme.

Floating-point to Varchar

floating-point-expression

An expression that returns a value that is a built-in floating-point data type.

The result is a varying-length character string representation of the argument in the form of an SQL floating-point constant. If the argument is negative, the first character of the result is a minus sign; otherwise, the first character is a digit. If the argument is zero, the result is 0E0.

The length attribute of the result is 24. The actual length of the result is the smallest number of characters that can represent the value of the argument such that the mantissa consists of a single digit other than zero followed by a period and a sequence of digits.

The CCSID of the result is determined from the application encoding scheme.

Decimal floating-point to Varchar

decimal-floating-point-expression

An expression that returns a value that is the built-in DECFLOAT data type.

The result is the varying-length character string representation of the argument in the form of an SQL decimal floating-point constant.

If the result value is one of the special values Infinity, sNaN, or NaN, the strings 'INFINITY', 'SNAN', or 'NAN', respectively, are returned. The DECFLOAT special value sNaN does not result in an exception when it is converted to a string.

²¹ If the BIF_COMPATIBILITY system parameter is set to V9_DECIMAL_VARCHAR, or if the SYSCOMPAT_V9.VARCHAR function is used, the format of the result matches the result of the [VARCHAR9](#) function with decimal input.

The length attribute of the result is 42. The actual length of the result is the smallest number of characters that represents the value of the argument, including the sign, digits, and period. Trailing zeros are significant. If the argument is negative, the first character of the result is a minus sign. Otherwise, the first character is a digit, or a letter if the result value is Infinity, sNaN, or NaN.

The CCSID of the result is determined from the application encoding scheme.

Character to Varchar

character-expression

An expression that returns a value that is a built-in character data type.

integer

Specifies the length attribute for the resulting varying-length character string. The value must be between 1 and 32764, expressed in the units that are either implicitly or explicitly specified. If the length is not specified, the length of the result is the same as the length of *character-expression*.

If CODEUNITS16, CODEUNITS32, or OCTETS is specified, see [“Determining the length attribute of the final result”](#) on page 108 for information about how to calculate the length attribute of the result string.

If a length attribute is not specified and if the *character-expression* is an empty string constant, the length attribute of the result is 1 and the result is an empty string. Otherwise, the length attribute of the result is the same as the length attribute of the first argument.

CODEUNITS16, CODEUNITS32, or OCTETS

Specifies the unit that is used to express *integer*. If *character-expression* is a character string that is defined as bit data, CODEUNITS16 and CODEUNITS32 cannot be specified.

CODEUNITS16

Specifies that *integer* is expressed in terms of 16-bit UTF-16 code units.

CODEUNITS32

Specifies that *integer* is expressed in terms of 32-bit UTF-32 code units.

OCTETS

Specifies that *integer* is expressed in terms of bytes.

For more information about CODEUNITS16, CODEUNITS32, and OCTETS, see [“String unit specifications”](#) on page 106.

The actual length of the result is the minimum of the length attribute of the result and the actual length of *character-expression*. If the length of *character-expression* is greater than the length attribute of the result, the result is truncated. Unless all the truncated characters are blanks appropriate for *character-expression*, a warning is returned.

If *character-expression* is bit data, the result is bit data. Otherwise, the CCSID of the result is the same as the CCSID of *character-expression*.

Graphic to Varchar

graphic-expression

An expression that returns a value that is a built-in graphic data type.

integer

The length attribute for the resulting varying-length graphic string. The value must be in the range 1–32704, expressed in the units that are either implicitly or explicitly specified.

If CODEUNITS16 or CODEUNITS32 is specified, see [“Determining the length attribute of the final result”](#) on page 108 for information about how to calculate the length attribute of the result string.

If a length attribute is not specified, the length attribute of the result is determined as follows (where *n* is the length attribute of the first argument):

- If the *graphic-expression* is the empty graphic string constant, the length attribute of the result is 1.
- If the result is SBCS data, the result length is *n*.

- If the result is mixed data, the result length is $3 * (\text{length}(\text{graphic-expression}))$.

CODEUNITS16 or CODEUNITS32

Specifies the unit that is used to express *integer*.

CODEUNITS16

Specifies that *integer* is expressed in terms of 16-bit UTF-16 code units.

CODEUNITS32

Specifies that *integer* is expressed in terms of 32-bit UTF-32 code units.

For more information about CODEUNITS16 or CODEUNITS32, see [“String unit specifications” on page 106](#).

The actual length of the result is the minimum of the length attribute of the result and the actual length of *graphic-expression*. If the length of the graphic expression is greater than the length attribute of the result, the result is truncated. Unless all the truncated characters were blanks appropriate for *graphic-expression*, a warning is returned.

The CCSID of the result is the character mixed CCSID that corresponds to the graphic CCSID of *graphic-expression*.

Datetime to Varchar

datetime-expression

An expression whose value has one of the following three built-in data types:

date

The result is a varying-length character string representation of the date in the format that is specified by the DATE precompiler option, if one is provided, or else field DATE FORMAT on installation panel DSNTIP4 specifies the format. If the format is to be LOCAL, field LOCAL DATE LENGTH on installation panel DSNTIP4 specifies the length of the result. Otherwise, the length attribute and actual length of the result is 10.

LOCAL denotes the local format at the Db2 that executes the SQL statement. If LOCAL is used for the format, a time exit routine must be installed at that Db2.

An error occurs if the second argument is specified and is not a valid value.

time

The result is a varying-length character string representation of the time in the format specified by the TIME precompiler option, if one is provided, or else field TIME FORMAT on installation panel DSNTIP4 specifies the format. If the format is to be LOCAL, the field LOCAL TIME LENGTH on installation panel DSNTIP4 specifies the length of the result. Otherwise, the length attribute and actual length of the result is 8.

LOCAL denotes the local format at the Db2 that executes the SQL statement. If LOCAL is used for the format, a time exit routine must be installed at that Db2.

An error occurs if the second argument is specified and is not a valid value.

timestamp

The result is the character string representation of the timestamp with time zone. The second argument must not be specified.

- If *datetime-expression* is a `TIMESTAMP (0) WITHOUT TIME ZONE`, the length of the result is 19.
- If *datetime-expression* is a `TIMESTAMP (p) WITHOUT TIME ZONE`, the length of the result is $20+p$ where p is the timestamp precision. The second argument must not be specified.
- If *datetime-expression* is a `TIMESTAMP (0) WITH TIME ZONE`, the length of the result is 25.
- If *datetime-expression* is a `TIMESTAMP (p) WITH TIME ZONE`, the length of the result is $26+p$ where p is the timestamp precision. The second argument must not be specified.

The CCSID of the result is determined from the context in which the function was invoked. For more information, see [Determining the encoding scheme and CCSID of a string \(Introduction to Db2 for z/OS\)](#).

Row ID to Varchar

row-ID-expression

An expression that returns a value that is a built-in row ID data type.

The result is a varying-length character string representation (VARCHAR) of the argument. It is bit data.

The length attribute of the result is 40. The actual length of the result is the length of *row-ID-expression*.

Notes

Syntax alternatives: [VARCHAR9](#) can be specified as an alternative to VARCHAR. The result of the function is the same, except when the first argument is decimal data.

Examples

Example 1: Assume that host variable *JOB_DESC* is defined as VARCHAR(8). Using sample table DSN8C10.EMP, set *JOB_DESC* to the varying-length string equivalent of the job description (column JOB defined as CHAR(8)) for the employee with the last name of 'QUINTANA'.

```
SELECT VARCHAR(JOB)
       INTO :JOB_DESC
       FROM DSN8C10.EMP
       WHERE LASTNAME = 'QUINTANA';
```

Example 2: FIRSTNME is a VARGRAPHIC(6) column in a Unicode table T1. One of its values is the string 'Jürgen' (X'004A00FC007200670055006E'). When FIRSTNME has this value:

Function ...	Returns ...
VARCHAR(FIRSTNME,3,CODEUNITS32)	'Jür' -- x'4AC3BC72'
VARCHAR(FIRSTNME,3,CODEUNITS16)	'Jür' -- x'4AC3BC72'
VARCHAR(FIRSTNME,3,OCTETS)	'Jü' -- x'4AC3BC'

Related concepts

[Data types of columns \(Introduction to Db2 for z/OS\)](#)

Related reference

[“VARCHAR9 scalar function” on page 620](#)

The VARCHAR9 function returns a fixed-length character string representation of the argument. The VARCHAR9 function is intended for compatibility with previous releases of Db2 for z/OS that depend on the result format that is returned for decimal input values in Version 9 and earlier.

[BIF COMPATIBILITY field \(BIF_COMPATIBILITY subsystem parameter\) \(Db2 Installation and Migration\)](#)

VARCHAR9 scalar function

The VARCHAR9 function returns a fixed-length character string representation of the argument. The VARCHAR9 function is intended for compatibility with previous releases of Db2 for z/OS that depend on the result format that is returned for decimal input values in Version 9 and earlier.

Important: For portable applications that might run on platforms other than Db2 for z/OS, use the [VARCHAR](#) function instead. Other Db2 family products do not support the VARCHAR9 function.

The first argument can be any value of the of the following types:

- Integer number
- Decimal number
- Floating-point number

- Character string
- Graphic string
- Datetime value
- Row ID value

If the first argument is a decimal number, the result is formatted as indicated in the following description. However, if the first argument is not a decimal number, the result is identical to the result of the VARCHAR function.

Decimal to Varchar:

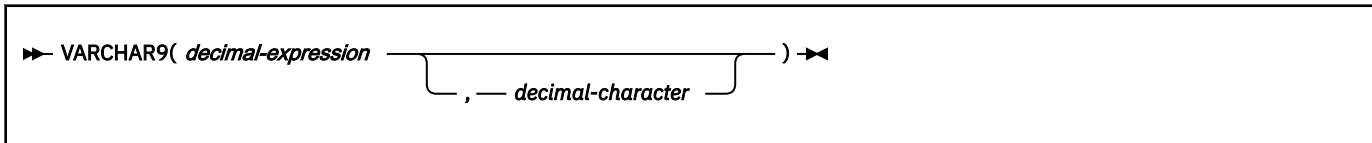

Decimal to Varchar

decimal-expression

An expression that returns a value that is a built-in decimal data type. To specify a different precision and scale for the expression's value, apply the DECIMAL function to the expression before applying the VARCHAR9 function.

decimal-character

Specifies the single-byte character constant (CHAR or VARCHAR) that is used to delimit the decimal digits in the result character string. The character must not be a digit, a plus sign (+), a minus sign (-), or a blank. The default is the period (.) or comma (,). For information about the factors that govern the choice, see [“Decimal point representation” on page 323](#)

The result is a varying-length character string representation of the argument. The result includes a decimal character and up to *p* digits where *p* is the precision of *decimal-expression* with a preceding minus sign if the argument is negative. Leading and trailing zeros are returned. The result includes a decimal character even if the scale of *decimal-expression* is zero.

The CCSID of the result is determined from the context in which the function was invoked. For more information, see [Determining the encoding scheme and CCSID of a string \(Introduction to Db2 for z/OS\)](#).

Examples

The following table shows the difference between the results of the VARCHAR and VARCHAR9 functions for example decimal number arguments.

Table 98. Example results of VARCHAR and VARCHAR9 functions

Decimal Argument	VARCHAR Function Result	VARCHAR9 Function Result
(000.1)	' .1 '	'0.1 '
(1000.)	'1000 '	'1000. '
(1.1)	'1.1 '	'1.1 '

Related concepts

[Data types of columns \(Introduction to Db2 for z/OS\)](#)

Related reference

[VARCHAR scalar function](#)

The VARCHAR function returns a varying-length character string representation of the value specified by the first argument.

[BIF COMPATIBILITY field \(BIF_COMPATIBILITY subsystem parameter\) \(Db2 Installation and Migration\)](#)

VARCHAR_BIT_FORMAT scalar function

The VARCHAR_BIT_FORMAT function returns a bit data string representation of a character string that has been formatted using a format-string.

```
➤ VARCHAR_BIT_FORMAT( expression _____ ) ➤  
                      |_____|  
                      ,format-string
```

expression

An expression that returns a value of any built-in numeric, character-string, or graphic-string data type that is not a LOB. A numeric or graphic argument is cast to a VARCHAR data type before evaluating the function. *expression* must not return bit data.

All leading and trailing blanks are removed from *expression* before evaluating the function.

If a *format-string* is specified, the length of *expression* must be equal to the length of the *format-string* and the value of *expression* must conform to the template specified by the *format-string*. If a *format-string* is not specified, the value of *expression* (after removing leading and trailing blanks) should be an even number of characters from the ranges '0' to '9', 'a' to 'f', and 'A' to 'F'. If the length is an odd number of characters, the string is padded on the right with one '0' character.

format-string

An expression that returns a built-in character string or graphic string data type. *format-string* contains a template for how the value for *expression* is to be interpreted. *format-string* must not return bit data.

The valid format strings are: 'xxxxxxxxx-xxxx-xxxx-xxxx-xxxxxxxxxxxxxx' and 'XXXXXXXX-XXXX-XXXX-XXXX-XXXXXXXXXXXX', where each 'x' or 'X' corresponds to one hexadecimal digit in the result. If 'X' is specified, the corresponding hexadecimal digit must not be a lower case character. If 'x' is specified, the corresponding hexadecimal digit must not be an upper case character.

The result is a varying-length bit data string. The length attribute of the result is half the length attribute of *expression*. If a *format-string* is not specified, the actual length is half the actual length of *expression* (after leading and trailing blanks have been removed and padding to an even number of characters). If a *format-string* is specified, the actual length is half the actual length of the *format-string* (after removing the non-digit separator characters). If any of the arguments can be null, the result can be null; if any of the arguments is null, the result is the null value.

Examples

Represent a Universal Unique Identifier in its binary form

```
SELECT VARCHAR_BIT_FORMAT ('d83d6360-1818-11db-9804-b622a1ef5492',  
'xxxxxxxx-xxxx-xxxx-xxxx-xxxxxxxxxxxxxx')  
FROM SYSIBM.SYSDUMMY1
```

Result returned: X'D83D6360181811DB9804B622A1EF5492'

Represent a Universal Unique Identifier in its binary form:

```
SELECT VARCHAR_BIT_FORMAT ('D83D6360-1818-11DB-9804-B622A1EF5492',  
'XXXXXXXX-XXXX-XXXX-XXXX-XXXXXXXXXXXX')  
FROM SYSIBM.SYSDUMMY1
```

Result returned: X'D83D6360181811DB9804B622A1EF5492'

Represent a string of hexadecimal characters in binary form:

```
SELECT VARCHAR_BIT_FORMAT ('ef01abc9') FROM SYSIBM.SYSDUMMY1
```

Result returned: X'EF01ABC9'

VARCHAR_FORMAT scalar function

The VARCHAR_FORMAT function returns a character string representation of the first argument, in the format indicated by *format-string* if it is specified.

Character to VARCHAR

► VARCHAR_FORMAT(*character-expression*) ◄

Timestamp to VARCHAR

► VARCHAR_FORMAT(*timestamp-expression* , *format-string*) ◄

Numeric to VARCHAR

► VARCHAR_FORMAT(*numeric-expression* , *format-string*) ◄

The schema is SYSIBM.

Character to VARCHAR

character-expression

An expression that returns a value that must be a built-in CHAR or VARCHAR data type. If a supplied argument is a GRAPHIC or VARGRAPHIC data type, it is first converted to VARCHAR before evaluating the function.

The length attribute of the result and the actual length are determined as follows:

- If *string-expression* is an empty string constant, the length attribute of the result is 1.
- Otherwise, the length attribute of the result is that same as the length attribute of *string-expression*.
- The actual length of the result is the minimum of the length attribute of the result and the actual length of *string-expression*.

The value of the result is the same as the value of *character-expression*.

If *character-expression* returns graphic data, the CCSID of the result is the character mixed CCSID that corresponds to the graphic argument. If *character-expression* returns bit data, the result is bit data. Otherwise, the CCSID of the result is the same as the CCSID of *character-expression*.

Timestamp to VARCHAR

timestamp-expression

An expression that returns a value that must be a DATE or TIMESTAMP, or a valid character string or graphic string representation of a date or timestamp that is not a CLOB or DBCLOB. If the argument is a graphic string representation of a data or timestamp, it is first converted to a character string before evaluating the function.

If *timestamp-expression* is a DATE or a valid string representation of a date, it is first converted to a TIMESTAMP(0) value, assuming a time of exactly midnight (00.00.00). If the HH12 format element is specified and the time component of the first argument is 24:00:00, the input timestamp value is adjusted to 00:00:00 and the date is incremented by one day.

For the valid formats of string representations of datetime values, see [“String representations of datetime values”](#) on page 120.

format-string

An expression that returns a built-in character string or graphic string data type that is not a LOB and has a length attribute that is not greater than 255 bytes. If the value is not a CHAR or VARCHAR data type, it is implicitly cast to VARCHAR before the function is evaluated. If the *expression* returns timestamp data type, the resulting substring must conform to the rules for formatting a timestamp. If the *expression* returns timestamp with a time zone, the resulting substring must conform to the rules for formatting a timestamp with time zone.

The value is a template for how *timestamp-expression* is to be formatted.

A valid *format-string* can contain a combination of the format elements listed below. Two format elements can be separated by one or more of the following separator characters.

- minus sign (-)
- period (.)
- forward slash (/)
- comma (,)
- apostrophe (')
- semicolon (;)
- colon (:)
- blank ()

Separator characters can also be specified at the start or end of *format-string*. *format-string* can also be an empty string, a string of blanks, or a string of separator characters.

The following table lists the valid format elements that *format-string* can contain.

Table 99. Valid format elements of format-string

Format element	Description (assuming the default is to return leading zeros)
AM or PM ¹	Meridian indicator (morning or evening) without periods. This format element uses the exact strings “AM” or “PM”.
A.M. or P.M. ¹	Meridian indicator (morning or evening) with periods. This format element uses the exact strings “A.M.” or “P.M.”.
CC	Century (00-99). If the last two digits of the four digit year are zero, the result is the first two digits of the year. Otherwise, the result is the first two digits of the year plus one.
D ¹	Day of the week (1-7). 1 is Sunday and 7 is Saturday.
DD	Day of the month (01-31).
DDD	Day of the year (001-366).

Table 99. Valid format elements of format-string (continued)

Format element	Description (assuming the default is to return leading zeros)
FF or FF n	Fractional seconds (0-999999). The number n is used to specify the number of digits to include in the returned value. Valid values for n are 1-12 (FF1-FF12) with no leading zeros. Specifying FF is equivalent to specifying FF6. If the timestamp precision of <i>timestamp-expression</i> is less than what is specified by the format, zero digits are padded onto the right of the specified digits.
HH	Hour of the day (01-12).
HH12	Hour of the day (01-12).
HH24	Hour of the day (00-24).
ID	ISO day of the week (1-7). 1 is Monday and 7 is Sunday.
IW	ISO week of the year (01-53). The week starts on Monday and includes 7 days. Week 1 is the first week of the year to contain a Thursday, which is equivalent to the first week of the year to contain January 4.
I	ISO year (0-9). The last digit of the year based on the ISO week that is returned.
IY	ISO year (00-99). The last two digits of the year based on the ISO week that is returned.
IYY	ISO year (000-999). The last three digits of the year based on the ISO week that is returned.
IYYY	ISO year (0000-9999). The last four digits of the year based on the ISO week that is returned.
J	Julian date (0000000-9999999).
MI	Minute (00-59).
MM	Month (01-12). January is 01.
MONTH, Month, or month ^{1,2}	Name of the month in uppercase, sentence case, or lowercase format in English.
MON, Mon, or mon ^{1,2}	Three-character abbreviated name of the month in uppercase, sentence case, or lowercase format in English.

Table 99. Valid format elements of format-string (continued)

Format element	Description (assuming the default is to return leading zeros)
NNNNNN	Microseconds (000000-999999). This format is equivalent to specifying FF6.
Q	Quarter (1-4). January through March is 1.
RR	Last two digits of the year (00-99). RR behaves the same as YY.
RRRR	Year (0000-9999). RRRR behaves the same as YYYY.
SS	Seconds (00-59).
SSSSS	Seconds since the previous midnight (00000-86400).
TZH	Time zone hour. (-24 to +24, This range accommodates daylight saving time changes.)
TZM	Time zone minute (00–59).
W	Week of the month (1-5). Week 1 starts on the first day of the month and ends on the seventh day.
WW	Week of the year (01-53). Week 1 begins on January 1 and ends on January 7.
Y	Last digit of the year (0-9).
YY	Last two digits of the year (00-99).
YYY	Last three digits of the year (000-999).
YYYY	Year (0000-9999).

Notes:

1. This format element is case sensitive. In cases where the format elements are ambiguous, the case insensitive format elements will be considered first.
2. Only these exact spellings and case combinations can be used. If this format element is specified in an invalid case combination an error is returned.

If *timestamp-expression* is a `TIMESTAMP WITHOUT TIME ZONE` value, *format-string* must not contain TZH or TZM.

The result is a representation of *timestamp-expression* in the format specified by *format-string*. *format-string* is interpreted as a series of format elements that can be separated by one or more separator characters. A string of characters in *format-string* is interpreted as the longest matching format element in the previous table. If two format elements that contain the same characters are not separated by a separator character, the specification is interpreted, starting from the left, as the longest matching element in the table, and continues until matches are found for the remainder of the format string. For example, 'YYYYYYDD' is interpreted as the format elements, 'YYYYY', 'YY', and 'DD'.

If the first argument is timestamp with time zone, or the second argument is a constant that contains a format element for a time zone, the resulting string contains a timestamp with time zone. Otherwise, the resulting string does not contain a time zone.

The result is the varying-length character string that contains *timestamp-expression* in the format that is specified by *format-string*. If *format-string* is a constant, The length attribute of the result is the maximum of 255 and the length attribute of *format-string*. Otherwise, the length attribute is 255. The *format-string* determines the actual length of the result. The actual length must not be greater than the length attribute of the result.

The result can be null; if any argument is null, the result is the null value.

The CCSID of the result is determined from the context in which the function is invoked. For more information, see [Determining the encoding scheme and CCSID of a string \(Introduction to Db2 for z/OS\)](#).

Decimal floating-point to VARCHAR

numeric-expression

An expression that returns a value of any built-in numeric data type. If the argument is not a decimal floating-point value, it is converted to DECFLOAT(34) for processing.

format-string

An expression that must return a value that is a built-in CHAR, VARCHAR, or numeric data type. If the value is not a CHAR or VARCHAR data type, it is implicitly cast to VARCHAR before evaluating the function. If the supplied argument is a GRAPHIC or VARGRAPHIC data type, it is first converted to VARCHAR before evaluating the function. The actual length must not be greater than 254 bytes.

The value is a template for how *numeric-expression* is to be formatted. A *format-string* must contain a valid combination of the listed format elements according to the following rules:

- A sign format element ('S', 'MI', 'PR') can be specified only one time.
- A decimal point format element can be specified only one time.
- Alphabetic format elements must be specified in upper case.
- A prefix format element can only be specified at the beginning of the format string, before any format elements that are not prefix format elements. When multiple prefix format elements are specified they can be specified in any order.
- A suffix format element can only be specified at the end of the format string, after any format elements that are not suffix format elements. When multiple suffix format elements are specified they can be specified in any order.
- A comma format element must not be the first format element that is not a prefix format element. There can be any number of comma format elements.
- Blanks must not be specified between format elements. Leading and trailing blanks can be specified but are ignored when formatting the result.

Table 100. Format elements for the VARCHAR_FORMAT (numeric to VARCHAR) function

Format element	Description
0	Each 0 represents a significant digit. Leading zeros in a number are formatted as zeros.
9	Each 9 represents a significant digit that can be included at the specified location. Leading zeros in a number are formatted as blanks. Only group separators that have at least one digit to the left of the separator are generated.

Table 100. Format elements for the VARCHAR_FORMAT (numeric to VARCHAR) function (continued)

Format element	Description
S	Prefix If <i>numeric-expression</i> is a negative number, a leading minus sign (-) is included. If <i>numeric-expression</i> is a positive number, a leading plus sign (+) is included in the result.
\$	Prefix A leading dollar sign (\$) is included the result.
MI	Suffix If <i>numeric-expression</i> is a negative number, a trailing minus sign (-) is included in the result. If <i>numeric-expression</i> is a positive number, a trailing blank is included in the result.
PR	Suffix If <i>numeric-expression</i> is a negative number, a leading less than character (<) and a trailing greater than character (>) are included in the result. If <i>numeric-expression</i> is a positive number, a leading blank and a trailing blank are included in the result.
, (comma)	Each comma represents a group separator that is included at the specified location in the result provided there would be a character to the left of it that is not a prefix character. This comma is used a group separator.
. (period/decimal point)	A period represents the decimal point that is included at the specified location in the result. This period is used as a decimal point.

If *format-string* is not specified, the function is equivalent to VARCHAR(*numeric-expression*).

The result is a representation of the *numeric-expression* value (which might be rounded) in the format that is specified by *format-string*. Prior to being formatted, the value of *numeric-expression* is rounded by using the ROUND function, if the number of digits to the right of the decimal point is greater than the number of digit format elements ('0' or '9') to the right of the decimal point in *format-string*. *format-string* is applied according to the following rules:

- The result does not include any digit characters to the left of the decimal point if all of the following conditions are true:
 - $-1 < \textit{rounded-input-value} < 1$
 - *format-string* does not include a '0' format element to the left of the decimal point
 - *format-string* includes at least one digit format element ('0' or '9') to the right of the decimal point
- The result includes a single 0 character immediately before the implicit or explicit decimal point if all of the following conditions are true:
 - The value of *rounded-input-value* is 0 or -0
 - *format-string* includes only the '9' digit format elements to the left of the implicit or explicit decimal point
 - *format-string* does not include any digit format elements to the right of the decimal point

- If *format-string* includes both '0' and '9' format elements to the left of the decimal point, the position of the first digit format element from the beginning of the format string determines the presence of leading blanks or zeroes. All '9' format elements specified after the leftmost '0' format element to the left of the implicit or explicit decimal point are treated the same as if a '0' format element had been specified. For example, the *format-string* value '99099' is the same as the value '99000'.
- If the number of digits to the right of the decimal point in *rounded-input-value* is less than the number of digit format elements to the right of the decimal point in *format-string*, the result includes the number of digit characters to the right of the decimal point that corresponds to the number of digit format elements to the right of the decimal point in *format-string*, padded to the right with zeros.
- If the number of digits to the left of the decimal point in *rounded-input-value* is greater than the number of digit format elements to the left of the decimal point in *format-string*, the result is a string of number sign (#) characters that matches the length that *format-string* produces in the result for valid values.
- If the value of *rounded-input-value* represents any of the positive or negative special values, Infinity, sNaN, or NaN, the string 'INFINITY', 'SNAN', 'NAN', '-INFINITY', '-SNAN', or '-NAN' is returned without using the format that is specified by *format-string*. The decimal floating-point special value sNaN does not result in an exception when converted to a string.
- If *format-string* does not include any of the sign format elements 'S', 'MI', or 'PR', and the value of *rounded-input-value* is negative, a minus sign (–) is included in the result. Otherwise, a blank is included in the resulting string. The minus sign or blank immediately precedes the first digit of the result to the left of the decimal point, or the decimal point if there are no digits to the left of the decimal point.

The result is a varying-length character string representation of *rounded-input-value*. If a single argument is specified the length attribute is 42. Otherwise the length attribute is 254. The actual length of the result is determined by *format-string*, if specified. Otherwise, the actual length of the result is the smallest number of characters that can represent the value of *rounded-input-value*. If the resulting string exceeds the length attribute of the result, the result will be truncated.

The CCSID of the result is determined from the context in which the function is invoked. For more information, see [Determining the encoding scheme and CCSID of a string \(Introduction to Db2 for z/OS\)](#)

Notes

Julian and Gregorian calendar:

For timestamp to a varying length character string, the transition from the Julian calendar to the Gregorian calendar on 15 October 1582 is taken into account by this function.

Determinism:

VARCHAR_FORMAT is a deterministic function.

Using the 'D', 'Y', and 'y' format elements:

Db2 for z/OS does not support the 'DY', 'dy', and 'Dy' format elements that are supported by other platforms. If 'DY' or 'Dy' is specified in the format string, it is interpreted as the 'D' format element followed by the 'Y' or 'y' format element. This behavior might change in a future release. To ensure that a 'D' followed by 'Y' or 'y' is interpreted as two separate format elements, include a separator character after the 'D' format element.

Syntax alternatives:

TO_CHAR is a synonym for VARCHAR_FORMAT.

Examples

Example 1: Timestamp to VARCHAR

Set the character variable *TVAR* to a string representation of the timestamp value of RECEIVED from CORPDATA.IN_TRAY, formatted as 'YYYY-MM-DD HH24:MI:SS'.

```
SELECT VARCHAR_FORMAT(RECEIVED, 'YYYY-MM-DD HH24:MI:SS')
       INTO :TVAR
       FROM CORPDATA.IN_TRAY;
```

Assuming that the value in the RECEIVED column is 'January 1, 2000 at 10am', the following string is returned:

```
'2000-01-01 10:00:00'
```

Assuming that the value in the RECEIVED column is now one second before the beginning of the year 2000 ('December 31, 1999 at 23:59:59pm', the following string is returned:

```
'1999-12-31 23:59:59'
```

The result would be different if HH12 had been specified instead of HH24 in the format string:

```
'1999-12-31 11:59:59'
```

Example 2: Timestamp to VARCHAR

Assume that the variable *TMSTAMP* is defined as a *TIMESTAMP* and has the following value: 2007-03-09-14.07.38.123456. The following examples show several invocations of the function and the resulting string values. The result data type in each case is *VARCHAR(255)*.

Function invocation	Result
<code>VARCHAR_FORMAT(TMSTAMP, 'YYYYMMDDHHMISSFF3')</code>	20070309020738123
<code>VARCHAR_FORMAT(TMSTAMP, 'YYYYMMDDHH24MISS')</code>	20070309140738
<code>VARCHAR_FORMAT(TMSTAMP, 'YYYYMMDDHHMI')</code>	200703090207
<code>VARCHAR_FORMAT(TMSTAMP, 'DD/MM/YY')</code>	09/03/07
<code>VARCHAR_FORMAT(TMSTAMP, 'MM-DD-YYYY')</code>	03-09-2007
<code>VARCHAR_FORMAT(TMSTAMP, 'J')</code>	2454169
<code>VARCHAR_FORMAT(TMSTAMP, 'Q')</code>	1
<code>VARCHAR_FORMAT(TMSTAMP, 'W')</code>	2
<code>VARCHAR_FORMAT(TMSTAMP, 'IW')</code>	10
<code>VARCHAR_FORMAT(TMSTAMP, 'WW')</code>	10
<code>VARCHAR_FORMAT(TMSTAMP, 'Month')</code>	March
<code>VARCHAR_FORMAT(TMSTAMP, 'MONTH')</code>	MARCH
<code>VARCHAR_FORMAT(TMSTAMP, 'MON')</code>	MAR

Example 3: Timestamp to VARCHAR

Assume that the variable *DTE* is defined as a *DATE* and has the value of '2007-03-09'. The following examples show several invocations of the function and the resulting string values. The result data type in each case is *VARCHAR(255)*:

Function invocation	Result
<code>VARCHAR_FORMAT(DTE, 'YYYYMMDD')</code>	20070309
<code>VARCHAR_FORMAT(DTE, 'YYYYMMDDHH24MISS')</code>	20070309000000

Assuming that today is May 26, 2008, the function returns:

```
26-MAY-2007
```

If the format string is 'YYYY-MON-YYYY', the result would be:

```
2007-MAY-2007
```

Example 4: Timestamp to VARCHAR

Format the hour of the specified string representation of a timestamp using a 12 hour clock and a 24 hour clock:

```
SELECT
  VARCHAR_FORMAT(TIMESTAMP('1979-04-07-14.00.00.000000'), 'HH'),
  VARCHAR_FORMAT(TIMESTAMP('1979-04-07-14.00.00.000000'), 'HH12'),
  VARCHAR_FORMAT(TIMESTAMP('1979-04-07-14.00.00.000000'), 'HH24'),
  VARCHAR_FORMAT(TIMESTAMP('2000-01-01-00.00.00.000000'), 'HH'),
  VARCHAR_FORMAT(TIMESTAMP('2000-01-01-12.00.00.000000'), 'HH'),
  VARCHAR_FORMAT(TIMESTAMP('2000-01-01-24.00.00.000000'), 'HH'),
  VARCHAR_FORMAT(TIMESTAMP('2000-01-01-00.00.00.000000'), 'HH12'),
  VARCHAR_FORMAT(TIMESTAMP('2000-01-01-12.00.00.000000'), 'HH12'),
  VARCHAR_FORMAT(TIMESTAMP('2000-01-01-24.00.00.000000'), 'HH12'),
  VARCHAR_FORMAT(TIMESTAMP('2000-01-01-00.00.00.000000'), 'HH24'),
  VARCHAR_FORMAT(TIMESTAMP('2000-01-01-12.00.00.000000'), 'HH24'),
  VARCHAR_FORMAT(TIMESTAMP('2000-01-01-24.00.00.000000'), 'HH24')
FROM SYSIBM.SYSDUMMY1;
```

The previous SELECT statement returns the following values:

```
'02' '02' '14' '12' '12' '12' '12' '12' '12' '12' '00' '12' '24'
```

Note that the values '00' and '24' on a 24 hour scale both map to a value of '12' on a 12 hour scale.

Example 5: Timestamp with time zone to VARCHAR

Assume that column PRSTSZ contains a timestamp with time zone value of '2008-02-29.20.00.000000 -08:00'. The following statement returns the value '2008-02-29 20:00:00.000000 -08:00'.

```
SELECT VARCHAR_FORMAT(PRSTSZ, 'YYYY-MM-DD HH24:MI:SS.NNNNNN TZH:TZM')
FROM PROJECT;
```

Example 6: decimal floating-point to VARCHAR

Assume that the variables *POSNUM* and *NEGNUM* are defined as DECFLOAT(34) and have the following values: '1234.56' and '-1234.56', respectively. The following examples show several invocations of the function and the resulting string values. The result data type in each case is VARCHAR(254).

Function invocation	Result
VARCHAR_FORMAT(POSNUM)	'1234.56'
VARCHAR_FORMAT(NEGNUM)	'-1234.56'
VARCHAR_FORMAT(POSNUM, '9999.99')	' 1234.56'
VARCHAR_FORMAT(NEGNUM, '9999.99')	'-1234.56'
VARCHAR_FORMAT(POSNUM, '99999.99')	' 1234.56'
VARCHAR_FORMAT(NEGNUM, '99999.99')	'-1234.56'
VARCHAR_FORMAT(POSNUM, '00000.00')	' 01234.56'
VARCHAR_FORMAT(NEGNUM, '00000.00')	'-01234.56'
VARCHAR_FORMAT(POSNUM, '9999.99MI')	'1234.56 '
VARCHAR_FORMAT(NEGNUM, '9999.99MI')	'1234.56- '
VARCHAR_FORMAT(POSNUM, 'S9999.99')	'+1234.56'
VARCHAR_FORMAT(NEGNUM, 'S9999.99')	'-1234.56'
VARCHAR_FORMAT(POSNUM, '9999.99PR')	' 1234.56 '
VARCHAR_FORMAT(NEGNUM, '9999.99PR')	'<1234.56>'

Function invocation	Result
VARCHAR_FORMAT(POSNUM, 'S\$9,999.99')	'+\$1,234.56'
VARCHAR_FORMAT(NEGNUM, 'S\$9,999.99')	'-\$1,234.56'

VARGRAPHIC scalar function

The VARGRAPHIC function returns a varying-length graphic string representation of the first argument.

Syntax for integer to vargraphic

[FL 502](#)

► VARGRAPHIC(*integer-expression*) ◄

Syntax for decimal to vargraphic

[FL 502](#)

► VARGRAPHIC(*decimal-expression* , — *decimal-character*) ◄

Syntax for floating-point to vargraphic

[FL 502](#)

► VARGRAPHIC(*floating-point-expression*) ◄

Syntax for decimal floating-point to vargraphic

[FL 502](#)

► VARGRAPHIC(*decimal-floating-point-expression*) ◄

Syntax for character to vargraphic:

► VARGRAPHIC(*character-expression* , — *integer* , — *CODEUNITS16* , — *CODEUNITS32*) ◄

Syntax for graphic to vargraphic:

► VARGRAPHIC(*graphic-expression* , — *integer* , — *CODEUNITS16* , — *CODEUNITS32*) ◄

The schema is SYSIBM.

The GRAPHIC function returns a varying length-graphic-string representation of:

- [FL 502](#) An integer number if the first argument is a SMALLINT, INTEGER, or BIGINT
- [FL 502](#) A decimal number if the first argument is a decimal number
- [FL 502](#) A double-precision floating-point number if the first argument is a DOUBLE or REAL
- [FL 502](#) A decimal floating-point number if the first argument is DECFLOAT
- A character string if the first argument is any type of character string
- A graphic string if the first argument is an EBCDIC or Unicode graphic string

The result can be null; if the first argument is null, the result is the null value.

The length attribute and actual length of the result are measured in double-byte characters because the result is a graphic string.

Integer to vargraphic

[FL 502](#)

integer-expression

An expression that returns a value that is an integer data type (either SMALLINT, INTEGER, or BIGINT).

The result is a varying-length graphic string of the argument in the form of an SQL integer constant. The actual length of the result is the smallest number of characters that can be used to represent the value of the argument. The result consists of *n* characters that are the significant digits that represent the value of the argument with a preceding minus sign if the argument is negative. A positive value starts with a digit. Leading zeroes are not included.

- If the argument is a small integer, the length attribute of the result is 6.
- If the argument is a large integer, the length attribute of the result is 11.
- If the argument is a big integer, the length attribute of the result is 20.

The CCSID of the result is 1200 (UTF-16).

Decimal to vargraphic

[FL 502](#)

decimal-expression

An expression that returns a value that is a built-in decimal data type. If a different precision and scale is wanted, the DECIMAL scalar function can be used to make the change. To specify a different precision and scale for the value of the expression, apply the DECIMAL function before applying the VARGRAPHIC function.

decimal-character

Specifies the single-byte character constant that is used to delimit the decimal digits in the result graphic string. The character must not be a digit, a plus sign (+), a minus sign (-), or a blank. The default is the period (.) or comma (,). For information on what factors govern the choice, see Decimal point representation.

The result is a varying-length graphic string representation of the first argument. The actual length of the result is the smallest number of characters that can be used to represent the result, except that trailing zeros are included. The result includes a decimal character and up to *p* digits, where *p* is the precision of the *decimal-expression* with a preceding minus sign if the argument is negative. A positive value starts with a digit or the decimal-character, and always includes at least one trailing blank. Leading zeros are not returned. If the scale of *decimal-expression* is zero, the decimal character is not returned. If the number of bytes in the result is less than the defined length of the result, the result is padded on the right with blanks.

The length of the result is $2+p$ where p is the precision of the *decimal-expression*.

The CCSID of the result is 1200 (UTF-16).

Floating-point to vargraphic

[FL 502](#)

floating-point-expression

An expression that returns a value that is a floating-point data type (DOUBLE or REAL).

The result is a varying-length graphic string representation of the argument in the form of an SQL floating-point constant. If the argument is negative, the first character of the result is a minus sign; otherwise, the first character is a digit. If the argument is zero, the result is OE0.

The length of the result is 24. The actual length of the result includes the smallest number of characters that can represent the value of the argument such that the mantissa consists of a single digit, other than zero, followed by a period and a sequence of digits. If the number of characters in the result is less than 24, the result is padded on the right with blanks.

The CCSID of the result is 1200 (UTF-16).

Decimal floating-point to vargraphic

[FL 502](#)

decimal-floating-point expression

An expression that returns a value that is a built-in decimal floating-point data type (DECFLOAT).

The result is a varying-length graphic string representation of the argument in the form of an SQL decimal floating-point constant.

If the result value is Infinity, sNaN, or NaN, the strings 'INFINITY', 'SNAN', and 'NAN', respectively, are returned. The DECFLOAT special value sNaN does not result in an exception when converted to a string.

The length of the result is 42. The actual length of the result is the smallest number of characters that represents the value of the argument, including the sign, digits, and the period. Trailing zeros are significant. If the argument is negative, the first character of the result is a minus sign. Otherwise, the first character is a digit, or a letter if the DECFLOAT value is Infinity, sNaN, or NaN.

The CCSID of the result is 1200 (UTF-16).

Character to vargraphic

character-expression

An expression that returns a value of a built-in character string data type that contains an EBCDIC-encoded or Unicode-encoded character string value. It cannot be BIT data. The argument does not need to be mixed data, but any occurrences of X'0E' and X'0F' in the string must conform to the rules for EBCDIC mixed data. (See [“Character strings” on page 102](#) for these rules.)

integer

The length attribute of the resulting varying-length graphic string. The value must be an integer constant in the range 1–16352.

If CODEUNITS16 or CODEUNITS32 is specified, see [“Determining the length attribute of the final result” on page 108](#) for information about how to calculate the length attribute of the result string.

If *integer* is not specified and if the *character-expression* is an empty string constant or has a value X'0EOF', the length attribute of the result is 1 and the result is an empty string. Otherwise, the length attribute of the result is the same as the length attribute of the first argument.

CODEUNITS16 or CODEUNITS32

Specifies the unit that is used to express *integer*. If CODEUNITS16 or CODEUNITS32 is specified, the input is EBCDIC, and there is no corresponding CCSID for EBCDIC GRAPHIC data, an error occurs.

CODEUNITS16

Specifies that *integer* is expressed in terms of 16-bit UTF-16 code units.

CODEUNITS32

Specifies that *integer* is expressed in terms of 32-bit UTF-32 code units.

For more information about CODEUNITS16 and CODEUNITS32, see [“String unit specifications” on page 106](#).

The actual length of the result is the minimum of the length attribute of the result and the actual length of *character-expression*. If the length of *character-expression*, as measured in single-byte characters, is greater than the specified length of the result, as measured in double-byte characters, the result is truncated. Unless all the truncated characters are blanks appropriate for *character-expression*, a warning is returned.

The CCSID of the result is the graphic CCSID that corresponds to the character CCSID of *character-expression*. If the input is EBCDIC and there is no system CCSID for EBCDIC GRAPHIC data, the CCSID of the result is X'FFFE'.

For EBCDIC input data:

Each character of *character-expression* determines a character of the result. The argument might need to be converted to the native form of mixed data before the result is derived. Let *M* denote the system CCSID for mixed data. The argument is not converted if any of the following conditions is true:

- The argument is mixed data and its CCSID is *M*.
- The argument is SBCS data and its CCSID is the same as the system CCSID for SBCS data. In this case, the operation proceeds as if the CCSID of the argument is *M*.

Otherwise, the argument is a new string *S* derived by converting the characters to the coded character set identified by *M*. If there is no system CCSID for mixed data, conversion is to the coded character set that the system CCSID for SBCS data identifies.

The result is derived from *S* using the following steps:

- Each shift character (X'0E' or X'0F') is removed.
- Each double-byte character remains as is.
- Each single-byte character is replaced by a double-byte character.

The replacement for a single-byte character is the equivalent DBCS character if an equivalent exists. Otherwise, the replacement is X'FEFE'. The existence of an equivalent character depends on *M*. If there is no system CCSID for mixed data, the DBCS equivalent of X'xx' for EBCDIC is X'42xx', except for X'40', whose DBCS equivalent is X'4040'.

For Unicode input data:

Each character of *character-expression* determines a character of the result. The argument might need to be converted to the native form of mixed data before the result is derived. Let *M* denote the system CCSID for mixed data. The argument is not converted if any of the following conditions is true:

- The argument is mixed data, and its CCSID is *M*.
- The argument is SBCS data, and its CCSID is the same as the system CCSID for SBCS data. In this case, the operation proceeds as if the CCSID of the argument is *M*.

Otherwise, the argument is a new string *S* derived by converting the characters to the coded character set identified by *M*.

The result is derived from *S* using the following steps:

- Each non-supplementary character is replaced by a Unicode double-byte character (a UTF-16 code point). A non-supplementary character in UTF-8 is in the range 1–3 bytes.
- Each supplementary character is replaced by a pair of Unicode double-byte characters (a pair of UTF-16 code points).

The replacement for a single-byte character is the Unicode equivalent character if an equivalent exists. Otherwise, the replacement is X'FFFD'.

Graphic to vargraphic

graphic-expression

An expression that returns a value of a built-in graphic string data type that contains an EBCDIC-encoded or Unicode-encoded graphic string value.

integer

The length attribute for the resulting varying-length graphic string. The value must be an integer constant in the range 1–16352.

If CODEUNITS16 or CODEUNITS32 is specified, see [“Determining the length attribute of the final result” on page 108](#) for information about how to calculate the length attribute of the result string.

If *integer* is not specified and if the *graphic-expression* is an empty string constant, the length attribute of the result is 1 and the result is an empty string. Otherwise, the length attribute of the result is the same as the length attribute of the first argument.

CODEUNITS16 or CODEUNITS32

Specifies the unit that is used to express *integer*. If CODEUNITS16 or CODEUNITS32 is specified, the input is EBCDIC, and there is no corresponding CCSID for EBCDIC GRAPHIC data, an error occurs.

CODEUNITS16

Specifies that *integer* is expressed in terms of 16-bit UTF-16 code units.

CODEUNITS32

Specifies that *integer* is expressed in terms of 32-bit UTF-32 code units.

For more information about CODEUNITS16 and CODEUNITS32, see [“String unit specifications” on page 106](#).

The actual length of the result depends on the number of characters in *graphic-expression*. If the length of *graphic-expression* is greater than the length specified, the result is truncated. Unless all of the truncated characters are double-byte blanks, a warning is returned.

The CCSID of the result is the same as the CCSID of *graphic-expression*.

Notes

FL 502 Casting numeric data to Unicode: The result of the VARGRAPHIC functions is Unicode (UTF-16) when the first argument is numeric data. The VARGRAPHIC function can only be invoked with numeric data for the first argument if the containing statement:

- references Unicode base tables or views only and the statement is qualified to be a single encoding scheme statement, or
- is considered a multiple encoding scheme statement and the application encoding scheme is Unicode.

Examples

Example 1:

FL 502 Assume that an EMPLOYEE_U table exists that is similar to the EMPLOYEE sample table except that it is a Unicode table. The EDLEVEL column is defined as SMALLINT. Assume that employee Christine Haas was in school for 18 years. The following statement returns the EDLEVEL column value as a varying-length graphic string.

```
SELECT VARGRAPHIC(EDLEVEL)
FROM EMPLOYEE_U
WHERE LASTNAME = 'HAAS'
```

The result value is G'18'.

Example 2:

FL 502 Assume that an EMPLOYEE_U table exists that is similar to the EMPLOYEE sample table except that it is a Unicode table. The SALARY and COMM columns are defined as DECIMAL with a precision of 9 and a scale of 2. Assume that employee Christine Haas has a salary of \$52750.00 and a commission of \$4220.00. Return the total of the salary and commission for employee Christine Haas as a varying-length graphic string using the comma decimal character.

```
SELECT VARGRAPHIC(SALARY + COMM, ',')
FROM EMPLOYEE_U
WHERE LASTNAME = 'HAAS'
```

The result value is G'56970,00'.

VERIFY_GROUP_FOR_USER scalar function

The VERIFY_GROUP_FOR_USER function returns a value that indicates whether the primary authorization ID and the secondary authorization IDs that are associated with the first argument are in the authorization names that are specified in the list of the second argument.

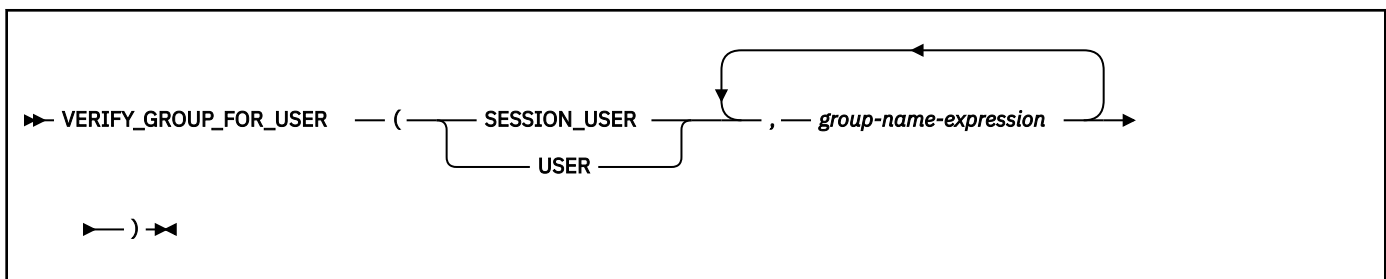

The schema is SYSIBM.

SESSION_USER or USER

Specifies the value of the SESSION_USER (or USER) special register.

group-name-expression

An expression that specifies an authorization name. The existence of the authorization name at the current server is not verified. *group-name-expression* must return a built-in character string data type or graphic string data type that is not a LOB. The string must have a length that does not exceed the maximum length of an SQL identifier. The content of the string is not folded to uppercase and is not left justified.

The result of the function is a large integer. The result cannot be null.

The result is 1 if the primary or secondary authorization IDs that are associated with the user that is identified by the SESSION_USER (or USER) special register is in the list that is specified by *group-name-expression*. Otherwise, the result is 0.

Notes

Syntax alternatives:

The VERIFY_GROUP_FOR_USER function is deterministic within a connection. It is not deterministic across connections. The function can be referenced in a CREATE MASK or a CREATE PERMISSION statement and is considered for table expressions or the merging of views.

Examples

Example 1:

In the following example, the EMPLOYEE table has column access control enabled. If the connection is established outside a trusted context and Mary, who has a secondary authorization ID of "MGR", queries the social security number of Tom from the EMPLOYEE table, the social security number is returned. When Mary is no longer a manager, the same query displays the last four digits of Tom's social security number.

Assume that a user who has SECADM authority has created the following column mask:

```
CREATE MASK SSN_MASK ON EMPLOYEE
FOR COLUMN SSN
RETURN
CASE WHEN VERIFY_GROUP_FOR_USER(SESSION_USER, 'MGR') = 1
      THEN SSN
      ELSE 'XXX-XX-' || SUBSTR(SSN, 8, 4)
END
ENABLE;

COMMIT;
```

An ALTER TABLE statement is then issued to activate the column mask on the EMPLOYEE table:

```
ALTER TABLE EMPLOYEE
ACTIVATE COLUMN ACCESS CONTROL;

COMMIT;
```

Mary connects to Db2, issues the following query, then disconnects from Db2:

```
SELECT SSN
FROM EMPLOYEE
WHERE NAME = 'Tom';
```

Mary receives Tom's social security number.

When Mary is no longer a manager, the secondary authorization ID, MGR is removed for her authorization ID. The next time Mary connects to Db2 and issues the following command, only the last four digits of Tom's social security number are displayed because of the column mask SSN_MASK:

```
SELECT SSN
FROM EMPLOYEE
WHERE NAME = 'Tom';
```

VERIFY_ROLE_FOR_USER scalar function

The VERIFY_ROLE_FOR_USER function returns a value that indicates whether the roles that are associated with the authorization ID that is specified in the first argument are included in the role names that are specified in the list of the second argument.

If the only way to acquire a role is under a trusted connection that is associated with a trusted context, the VERIFY_ROLE_FOR_USER function is equivalent to the VERIFY_TRUSTED_CONTEXT_ROLE_FOR_USER function.

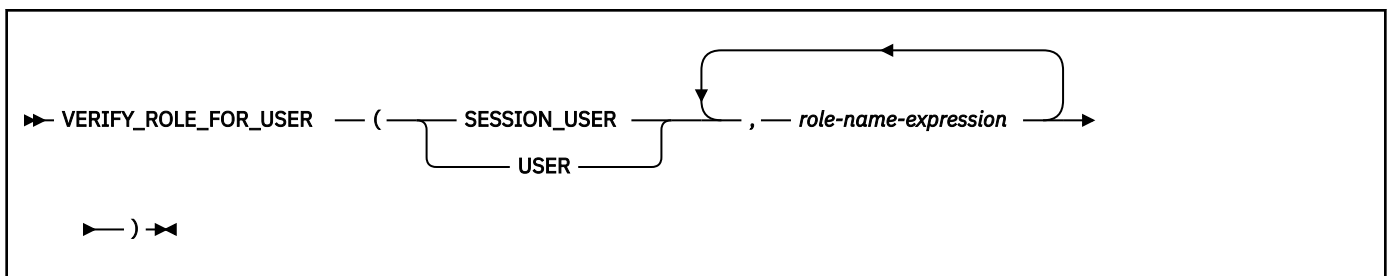

The schema is SYSIBM.

SESSION_USER or USER

Specifies the value of the SESSION_USER (or USER) special register.

role-name-expression

An expression that specifies a role name. The existence of the role name at the current server is not verified. *role-name-expression* must return a built-in character string data type or graphic string data type that is not a LOB. The string must have a length that does not exceed the maximum length of an SQL identifier. The content of the string is not folded to uppercase and is not left justified.

The result of the function is a large integer. The result cannot be null.

The result is 1 if any of the roles that are associated with the user that is identified by the `SESSION_USER` (or `USER`) special register is in the list of roles specified by *role-name-expression*. Otherwise, the result is 0.

Notes

Determinism:

The `VERIFY_ROLE_FOR_USER` function is deterministic within a trusted connection. It is not deterministic across trusted connections. The function can be referenced in a `CREATE MASK` or a `CREATE PERMISSION` statement and is considered for table expressions or the merging of views.

Examples

Example 1:

Assume that the following statements have been issued to create specific roles and the trusted context `CTX1`:

```
CREATE ROLE EMPLOYEE;
COMMIT;

CREATE ROLE MGR;
COMMIT;

CREATE ROLE PAYROLL;
COMMIT;

CREATE TRUSTED CONTEXT CTX1
  BASED UPON CONNECTION USING SYSTEM AUTHID ADMF001
  ATTRIBUTES (ADDRESS '9.30.131.203', ENCRYPTION 'LOW')
  DEFAULT ROLE EMPLOYEE
  ENABLE
  WITH USE FOR SAM, JOE ROLE MGR WITH AUTHENTICATION;

COMMIT;
```

Joe, who is a manager, issues the following dynamic query through the trusted connection `CTX1` to view the salaries of the employees in the `DSN8910.EMP` table that are in his department:

```
SELECT SALARY FROM DSN8910.EMP
  WHERE VERIFY_ROLE_FOR_USER(SESSION_USER, 'MGR', 'PAYROLL') = 1
  AND WORKDEPT = ?;
```

Example 2:

For the following example, suppose that a user with `SECADM` authority needs to control access for specific users who execute a statement that is accessing a table:

Is the current user, B, using role X to run a statement owned by user C

```
SESSION_USER = B AND
VERIFY_ROLE_FOR_USER(SESSION_USER, 'X')
```

Is the current user, B, using role X to run a statement owned by role D

```
SESSION_USER = B AND
VERIFY_ROLE_FOR_USER(SESSION_USER, 'X')
```

Is the current user, B, using role B to execute a dynamic statement

```
SESSION_USER = B AND
VERIFY_ROLE_FOR_USER(SESSION_USER, 'B')
```

VERIFY_TRUSTED_CONTEXT_ROLE_FOR_USER scalar function

The VERIFY_TRUSTED_CONTEXT_ROLE_FOR_USER function returns a value that indicates whether the authorization ID that is associated with first argument has acquired a role in a trusted connection and whether that acquired role is included in the role names that are specified in the list of the second argument.

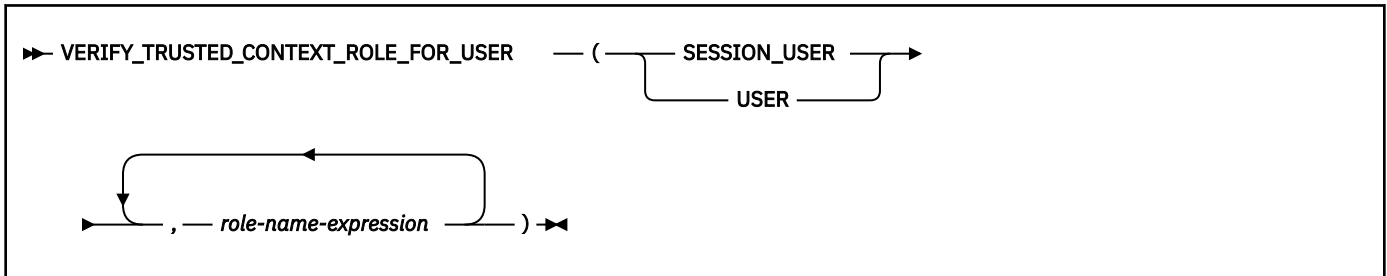

The schema is SYSIBM.

SESSION_USER or USER

Specifies the value of the SESSION_USER (or USER) special register.

role-name-expression

An expression that specifies a role name. The existence of the role name at the current server is not verified. *role-name-expression* must return a built-in character string data type or graphic string data type that is not a LOB. The string must have a length that does not exceed the maximum length of an SQL identifier. The content of the string is not folded to uppercase and is not left justified.

The result of the function is a large integer. The result cannot be null.

The result is 1 if the user that is identified by the SESSION_USER (or USER) special register has acquired a role under a trusted connection that is associated with a trusted context and that role is in the list of *role-name-expression*. Otherwise, the result is 0.

Notes

Determinism:

The VERIFY_TRUSTED_CONTEXT_ROLE_FOR_USER function is deterministic within a trusted connection. It is not deterministic across trusted connections. The function can be referenced in a CREATE MASK or a CREATE PERMISSION statement and is considered for table expressions or the merging of views.

Examples

Example 1:

Assume that the following statements have been issued to create specific roles and the trusted context CTX1:

```
CREATE ROLE EMPLOYEE;  
COMMIT;  
  
CREATE ROLE MGR;  
COMMIT;  
  
CREATE ROLE PAYROLL;  
COMMIT;  
  
CREATE TRUSTED CONTEXT CTX1  
  BASED UPON CONNECTION USING SYSTEM AUTHID ADMF001  
  ATTRIBUTES (ADDRESS '9.30.131.203', ENCRYPTION 'LOW')  
  DEFAULT ROLE EMPLOYEE  
  ENABLE  
  WITH USE FOR SAM, JOE ROLE MGR WITH AUTHENTICATION;  
  
COMMIT;
```

Joe, who is a manager, issues the following dynamic query through the trusted connection CTX1 to view the salaries of the employees in the DSN8910.EMP table that are in his department:

```
SELECT SALARY FROM DSN8910.EMP
WHERE VERIFY_TRUSTED_CONTEXT_ROLE_FOR_USER(SESSION_USER, 'MGR', 'PAYROLL')= 1
AND WORKDEPT = ?;
```

Example 2:

For the following example, suppose that a user with SECADM authority needs to control access for specific users who execute a statement that is accessing a table:

Is the current user, B, using role X to run a statement owned by user C?

```
SESSION_USER = B AND
VERIFY_TRUSTED_CONTEXT_ROLE_FOR_USER(SESSION_USER, 'X')
```

Is the current user, B, using role X to run a statement owned by role D?

```
SESSION_USER = B AND
VERIFY_TRUSTED_CONTEXT_ROLE_FOR_USER(SESSION_USER, 'X')
```

Is the current user, B, using role B to execute a dynamic statement?

```
SESSION_USER = B AND
VERIFY_TRUSTED_CONTEXT_ROLE_FOR_USER(SESSION_USER, 'B')
```

WEEK scalar function

The WEEK function returns an integer in the range of 1 to 54 that represents the week of the year. The week starts with Sunday, and January 1 is always in the first week.

► WEEK(*expression*) ◄

The schema is SYSIBM.

The argument must be an expression that returns a value of one of the following built-in data types: a date, a timestamp, a character string, or a graphic string. If *expression* is a character or graphic string, it must not be a CLOB or DBCLOB, and its value must be a valid string representation of a date or timestamp with an actual length that is not greater than 255 bytes. For the valid formats of string representations of dates and timestamps, see [“String representations of datetime values”](#) on page 120.

If *expression* is a timestamp with a time zone, or a valid string representation of a timestamp with a time zone, the result is determined from the UTC representation of the datetime value.

The result of the function is a large integer.

The result can be null; if the argument is null, the result is the null value.

Example 1: Using sample table DSN8C10.PROJ, set the integer host variable *WEEK* to the week of the year that project 'AD2100' ended.

```
SELECT WEEK(PRENDATE)
INTO :WEEK
FROM DSN8C10.PROJ
WHERE PROJNO = 'AD2100';
```

The result is that *WEEK* is set 6.

Example 2: The following invocations of the WEEK function returns the same result:

```
SELECT WEEK('1993-08-10-20.00.00'),
       WEEK('1993-08-10-20.00.00-08:00'),
       WEEK('1993-08-10-20.00.00+09:00')
FROM SYSIBM.SYSDUMMY1;
```

For each invocation of the WEEK function in this SELECT statement, the result is 33.

When the input argument contains a time zone, the result is determined from the UTC representation of the input value. The string representations of a timestamp with a time zone in the SELECT statement all have the same UTC representation: '1993-08-10-20.00.00'.

WEEK_ISO scalar function

The WEEK_ISO function returns an integer in the range of 1 to 53 that represents the week of the year. The week starts with Monday and includes seven days. Week 1 is the first week of the year that contains a Thursday, which is equivalent to the first week that contains January 4.

►► WEEK_ISO(*expression*) ◀◀

With the WEEK_ISO function, the first one, two, or three days in January might be included in the last week of the previous year. Likewise, the last one, two, or three days in December might be included in the first week of the next year.

The schema is SYSIBM.

The argument must be a date, a timestamp, or a valid string representation of a date or timestamp. A string representation must not be a CLOB or DBCLOB value and must have an actual length that is not greater than 255 bytes. For the valid formats of string representations of dates and timestamps, see [“String representations of datetime values” on page 120](#).

If *expression* is a timestamp with a time zone, or a valid string representation of a timestamp with a time zone, the result is determined from the UTC representation of the datetime value.

The result of the function is a large integer.

The result can be null; if the argument is null, the result is the null value.

Example 1: Using sample table DSN8C10.PROJ, set the integer host variable WEEKISO to the week of the year that project 'AD2100' ended.

```
SELECT WEEK_ISO(PRENDATE)
       INTO :WEEKISO
       FROM DSN8C10.PROJ
       WHERE PROJNO = 'AD2100';
```

Example 2: The following list shows what is returned by the WEEK_ISO function for various dates.

DATE:	WEEK_ISO returns:
-----	-----
2003-12-28	52
2003-12-31	1
2004-01-01	1
2005-01-01	53
2005-01-04	1
2005-12-31	52
2006-01-01	52
2006-01-03	1

Example 3: The following invocations of the WEEK_ISO function returns the same result:

```
SELECT WEEK_ISO('1993-08-10-20.00.00'),
       WEEK_ISO('1993-08-10-20.00.00-08:00'),
       WEEK_ISO('1993-08-10-20.00.00+09:00')
FROM SYSIBM.SYSDUMMY1;
```

For each invocation of the WEEK_ISO function in this SELECT statement, the result is 32.

When the input argument contains a time zone, the result is determined from the UTC representation of the input value. The string representations of a timestamp with a time zone in the SELECT statement all have the same UTC representation: '1993-08-10-20.00.00'.

WRAP scalar function

The WRAP built-in function encodes a readable data definition statement into an obfuscated data definition statement. The procedural logic and embedded SQL statements in an *obfuscated data definition statement* are scrambled in such a way that any intellectual property in the logic cannot be easily extracted.

►► WRAP — (— *object-definition-string* —) ►►

The schemas is SYSIBM.

The WRAP function is not deterministic.

object-definition-string

A string of any built-in character type that contains any of the following data definition statements:

- CREATE FUNCTION (compiled SQL scalar)
- CREATE FUNCTION (inlined SQL scalar)
- CREATE FUNCTION (SQL table)
- CREATE PROCEDURE (SQL - native)
- CREATE TRIGGER (basic)
- CREATE TRIGGER (advanced)

object-definition-string must not be bit data, and it cannot contain the VERSION keyword.

The result is a string of type CLOB(2M) that contains an encoded version of the input statement. The result cannot be null. The encoded statement consists of the following parts:

- The original statement up to and including the routine signature or trigger name.
- The WRAPPED keyword.
- The product identifier of the database manager that invoked the function.

The product identifier (PRDID) value is an 8-byte character value in *pppvrrm* format, where: *ppp* is a 3-letter product code; *vv* is the version; *rr* is the release; and *m* is the modification level. In Db2 12 for z/OS, the modification level indicates a range of function levels:

DSN12015 for V12R1M500 or higher.

DSN12010 for V12R1M100.

For more information, see [Product identifier \(PRDID\) values in Db2 for z/OS \(Db2 Administration Guide\)](#).

- The encoded remainder of the data definition statement, in the form of a string of letters (a-z and A-Z), digits (0-9), underscores, and colons. It is converted to Unicode UTF-8 before it is encoded. An error is issued if *object-definition-string* cannot be converted or if the intermediate string exceeds the maximum length for SQL statements. A warning occurs if a character is converted to the substitution character.

The encoded data definition statement can be up to one-third longer than the plain text form of the statement. If the result exceeds the maximum length for SQL statements, an error is issued.

Important: The encoding of the statement is meant to obfuscate the content and is not considered a form of strong encryption.

Examples

Example 1

The following example, produces an obfuscated version of a function that computes a yearly salary from an hourly wage given a 40 hour work week.

```
SELECT WRAP('CREATE FUNCTION salary(wage DECFLOAT)
RETURNS DECFLOAT
RETURN wage * 40 * 52')
FROM SYSIBM.SYSDUMMY1
```

The result is similar to the following form:

```
CREATE FUNCTION salary(wage DECFLOAT) WRAPPED DSN12015
ab1GWmdiWmtyTmduTmJqTmtaUmtCUMzqUmdiXodK3idaWmdaWmdaWmZG1mIaG
icaGy31TyStm_qGbe3sDxdxjtC8ymVGLpMXnuL81kmNuRhhZ6qYJ2YYdXGaa
```

Example 2

The following statement produced an obfuscated version of a trigger that sets a complex default value.

```
SELECT WRAP('CREATE OR REPLACE TRIGGER trig1
BEFORE INSERT ON emp
REFERENCING NEW AS n FOR EACH ROW
WHEN (n.bonus IS NULL)
SET n.bonus = n.salary * .04')
FROM SYSIBM.SYSDUMMY1
```

The result is similar to the following form:

```
CREATE TRIGGER trig1 WRAPPED DSN12015
ab1GWmdiWmtyTmduTmJqTmtaUmtGUnteUmZKWmtqWidaWmdaWmdaXmdyWncaGica
GK6ot_81NzyodncdrRIJFp_tBjpJeIwg_dTKNHcdtHPSaNCpmqBKH2pMwExkRTJW
Zr:dJd0_gSbehW:4Xx1UGPGnDxvmJfa5ZAG0r_1sfFiyaPrk0Xzt5UMTmsASfyJR
ksbPfM2d1ATbq:0RW
```

Related tasks

[Obfuscating source code of SQL procedures, SQL functions, and triggers \(Db2 Administration Guide\)](#)

Related reference

[CREATE_WRAPPED stored procedure](#)

The `CREATE_WRAPPED` procedure encodes a readable data definition statement into an obfuscated data definition statement and then deploys the object in the database. The procedural logic and embedded SQL statements in an *obfuscated data definition statement* are scrambled in such a way that any intellectual property in the logic cannot be easily extracted.

XMLATTRIBUTES scalar function

The `XMLATTRIBUTES` function constructs XML attributes from the arguments. This function can be used as an argument only for the `XMLELEMENT` function.

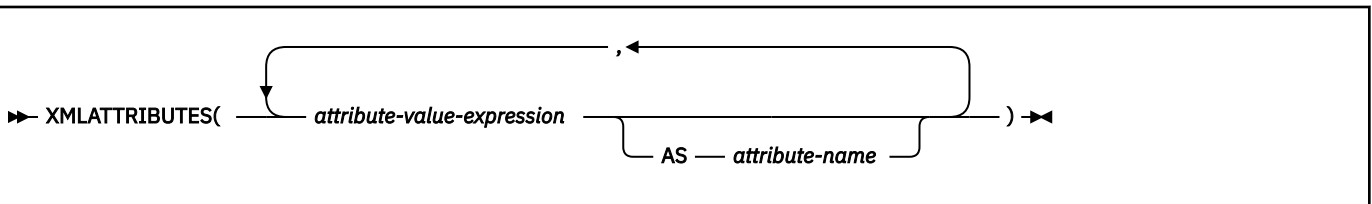

The schema is `SYSIBM`.

The result is an XML sequence that contains an XQuery attribute node for each non-null *attribute-value-expression* argument.

attribute-value-expression

An expression that returns a value for the attribute. The data type of *attribute-value-expression* must not be `ROWID`, a `LOB`, a distinct type that is based on a `ROWID` or a `LOB`, or `XML`.

The result of *attribute-value-expression* is mapped to an XML value according to the rules for mapping an SQL value to an XML value. If the expression is not a simple column reference, an attribute name must be specified.

AS *attribute-name*

Specifies an attribute name. The name is an SQL identifier that must be in the form of an XML qualified name, or `QName`. If *attribute-name* is a qualified name, the namespace prefix must be declared within the scope of the qualified name.

attribute-name cannot be 'xmlns' or prefixed with 'xmlns:'. A namespace is declared using the function XMLNAMESPACES. The attribute names for an element must be unique for the XML element to be well-formed.

If *attribute-name* is not specified, the expression for *attribute-value* must be a column name. The attribute name will be created from the column name using the fully escaped mapping from a column name to an XML attribute name.

The result of the function is an XML value. The result can be null; if all *attribute-value-expression* arguments are null, the result is the null value.

XMLCOMMENT scalar function

The XMLCOMMENT function returns an XML value with a single comment node from a string expression. The content of the comment node is the value of the input string expression, mapped to Unicode (UTF-8).

►► XMLCOMMENT(*string-expression*) ◄◄

The schema is SYSIBM.

string-expression

An expression that returns a value of a built-in character or graphic string that is not a LOB and is not bit data. The result of *string-expression* is converted to UTF-8 and then parsed to check for conformance to the content of XML comment as specified by the following rules:

- '--' (double-hyphen) must not occur in the string expression
- The string expression must not end with a hyphen ('-')
- Each character of the string can be any Unicode character, excluding the surrogate blocks, X'FFFE', and X'FFFF'

If *string-expression* does not conform to the previous rules, an error is returned.

The result of the function is an XML value that is an XML sequence that contains one XML comment node.

The result can be null; if the argument is null, the result is the null value.

Example: Generate an XML comment:

```
SELECT XMLCOMMENT('This is an XML comment')
FROM SYSIBM.SYSDUMMY1;
```

The result of the query would look similar to the following result:

```
<!--This is an XML comment-->
```

XMLCONCAT scalar function

The XMLCONCAT function returns an XML sequence that contains the concatenation of a variable number of XML input arguments.

►► XMLCONCAT(*XML-expression* , *XML-expression* , ...) ◄◄

The schema is SYSIBM.

XML-expression

An expression that returns an XML value.

The data type of the result is XML. The result of the function is an XML sequence that contains the concatenation of the non-null input XML values. Null values in the input are ignored. The result can be null; if the result of every input value is null, the result is the null value.

Example: Concatenate first name and last name elements by using 'first' and 'last' element names for each employee.

```
SELECT XMLSERIALIZE( XMLCONCAT
                    ( XMLELEMENT ( NAME "first", e.fname),
                      XMLELEMENT ( NAME "last", e.lname)
                    ) ) AS "result"
FROM employees e;
```

The result of the query would look similar to the following result:

```
result
-----
<first>John</first><last>Smith</last>
<first>Mary</first><last>Smith</last>
```

XMLDOCUMENT scalar function

The XMLDOCUMENT function returns an XML value with a single document node and zero or more nodes as its children. The content of the generated XML document node is specified by a list of expressions.

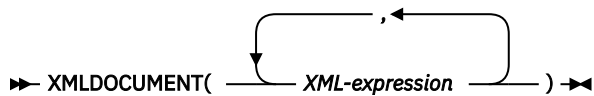

The schema is SYSIBM.

XML-expression

An expression that returns an XML value. A sequence item in the XML value must not be an attribute node. If *XML-expression* returns a null value, it is ignored for further processing. However, if all *XML-expression* values are null, the result of the function is the null value.

The result of the function is an XML value.

The result can be null; if all of the arguments are null, the result is the null value.

The resulting XML value is built from the list of *XML-expression* arguments. The children of the resulting document node are constructed as follows:

1. All of the non-null XML values that are returned by *XML-expression* are concatenated together. The result is a sequence of nodes or atomic values, which is referred to in the following steps as the *input sequence*. Any document node in the input sequence is replaced by copies of its children.
2. For each node in the input sequence, a new deep copy of the node is constructed. A *deep copy* of a node is a copy of the whole subtree that is rooted at that node, including the node itself and its descendants and attributes. Each copied node has a new node identity. Copied element nodes are given the type annotation 'xdt:untyped', and copied attribute nodes are given the type annotation 'xdt:untypedAtomic'. For each adjacent sequence of one or more atomic values that is returned in the input sequence, a new text node is constructed that contains the result of casting each atomic value to a string, with a single blank character inserted between adjacent values. The resulting sequence of nodes is called the *content sequence*. Adjacent text nodes in the content sequence are merged into a single text node by concatenating the contents of the text nodes with no intervening blanks. After concatenation, any text node that contains a zero-length string is deleted from the content sequence.
3. The nodes in the content sequence become the children of the new document node.

Example 1: Insert a constructed document into an XML column:

```
INSERT INTO T1 VALUES(123,
                     (SELECT XMLDOCUMENT(XMLELEMENT(NAME "Emp",
```

```

e.fname || ' ' || e.lname),
XMLCOMMENT('This is just a simple example'))
FROM EMPLOYEE e
WHERE e.empid = 123));

```

XMLELEMENT scalar function

The XMLELEMENT function returns an XML value that is an XML element node.

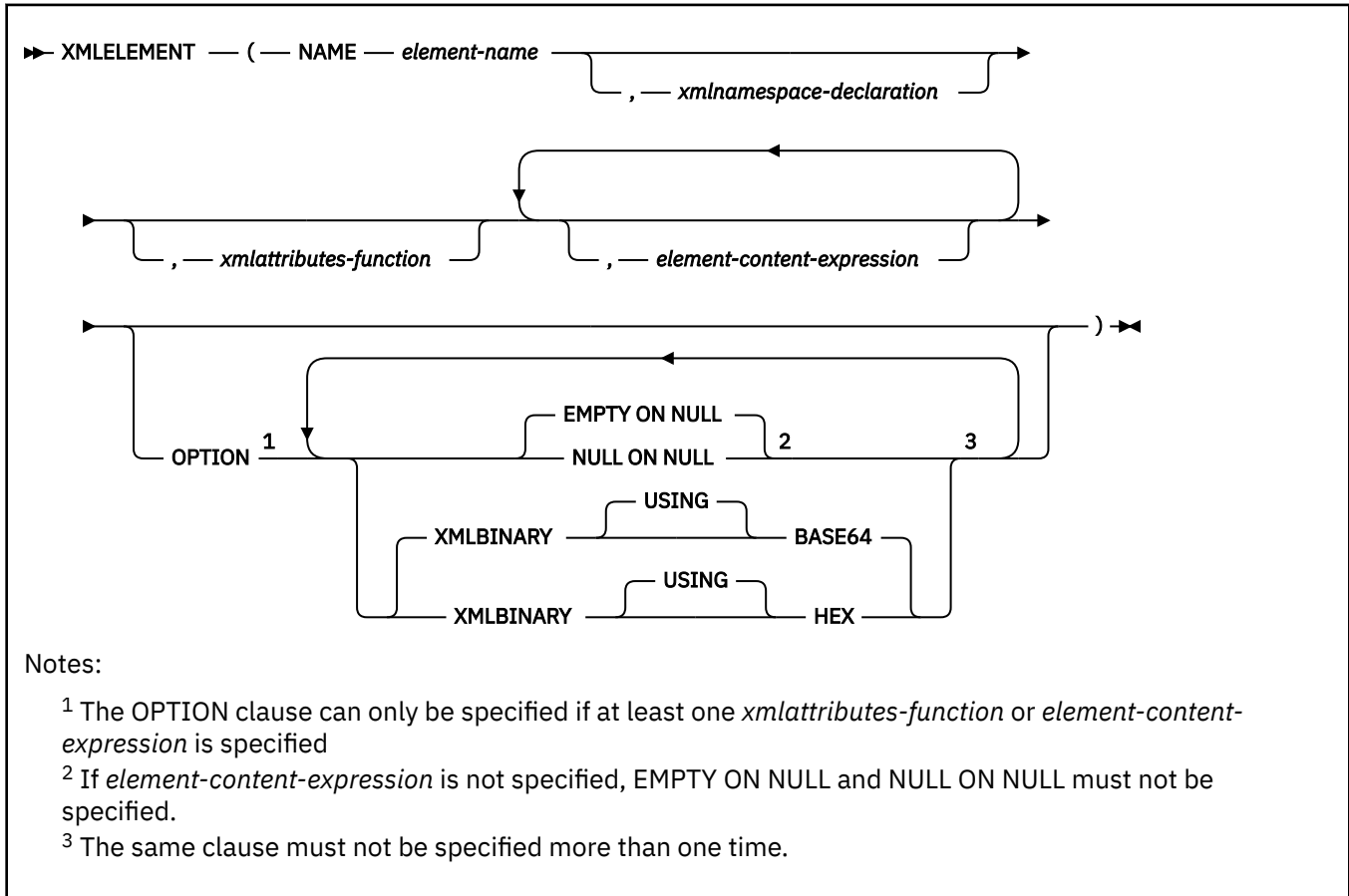

The schema is SYSIBM.

NAME *element-name*

Specifies the name of an XML element. *element-name* is an SQL identifier that must be in the form of an XML qualified name, or QName. If the name is qualified, the namespace prefix must be declared within the scope.

xmlnamespaces-declaration

Specifies the XML namespace declarations that are the result of the XMLNAMESPACES function. The namespaces that are declared are in the scope of the XMLELEMENT function. The namespaces apply to any nested XML functions within the XMLELEMENT function, regardless of whether or not they appear inside another subselect. See “XMLNAMESPACES scalar function” on page 656 for more information on declaring XML namespaces.

If *xmlnamespaces-declaration* is not specified, namespace declarations are not associated with the constructed XML element node.

xmlattributes-function

Specifies the attributes for the XML element. The attributes are the result of the XMLATTRIBUTES function. See “XMLATTRIBUTES scalar function” on page 644 for more information on constructing attributes.

If *xmlattributes-function* is not specified, attributes are not explicitly part of the constructed XML element node.

element-content-expression

The content of the generated XML element node is specified by an expression or a list of expressions. Each *element-content-expression* must return a value of any built-in data type or distinct type. The expression is used to construct the namespace declarations, attributes, and content of the constructed element node.

If *element-content-expression* is not specified, an empty string is used as the content for the element and NULL ON NULL or EMPTY ON NULL must not be specified.

OPTION

Specifies additional options for constructing the XML element. This clause has no impact on nested invocations of the XMLELEMENT function invocations that are specified in *element-content-expression*.

EMPTY ON NULL or NULL ON NULL

Specifies if a null value or an empty element is returned when the values of each *element-content-expression* is a null value. This option only affects null handling of element contents, not attribute values. The option is not inherited by a nested invocation of XMLELEMENT function within an *element-content-expression*.

EMPTY ON NULL

If the value of each *element-content-expression* is null, an empty element is returned.

EMPTY ON NULL is the default.

NULL ON NULL

If the value of each *element-content-expression* is null, a null value is returned.

XMLBINARY USING BASE64 or XMLBINARY USING HEX

Specifies the assumed encoding of binary input data, character string data with the FOR BIT DATA attribute, ROWID, or a distinct type that is based on one of these types. The encoding applies to element content or attribute values.

XMLBINARY USING BASE64

Specifies that the assumed encoding is base64 characters, as defined for XML schema type xs:base64Binary. The base64 encoding uses a 64-character subset of US-ASCII (10 digits, 26 lowercase characters, 26 uppercase characters, '+' and '/') to represent every 6 bits of the binary or bit data by one printable character in the subset. These characters are selected so that they are universally representable. In addition, the '=' character represents a line pad character. Using this method, the size of the encoded data is 33 percent larger than the original binary or bit data.

XMLBINARY USING BASE64 is the default.

XMLBINARY USING HEX

Specifies that the assumed encoding is hexadecimal characters as defined for XML schema type xs:hexBinary encoding. The hex encoding represents each byte (8 bits) with two hexadecimal characters. Using this method, the encoded data is twice the size of the original binary or bit data.

This function takes an element name, an optional collection of namespace declarations, an optional collection of attributes, and zero or more optional arguments that make up the content of the XML element. The result is an XML sequence that contains an XML element node or the null value. If the results of all *element-content-expression* arguments are empty strings, the result is an XML sequence that contains an empty element.

The result of the function is an XML value. The result can be null; if all *element-content-expression* arguments are null and the NULL ON NULL option is in effect, the result is the null value.

Notes

Constructing an element node:

The resulting element node is constructed as follows:

1. *xmlns:declaration* adds a set of in-scope namespaces for the constructed element. Each in-scope namespace associates a namespace prefix (or the default namespace) with a namespace URI. The in-scope namespaces define the set of namespace prefixes that are available for interpreting QNames within the scope of the element.
2. If the *xml:attributes-function* is specified, it is evaluated and the result is a sequence of attribute nodes.
3. Each *element-content-expression* is evaluated and the result is converted into a sequence of nodes as follows:
 - If the result type is not XML, it is converted to an XML text node that contains the result of the *element-content-expression* this is mapped to XML.
 - If the result type is XML, the result is a sequence of items. Some of the items in that sequence might be document nodes. Each document node in the sequence is replaced by the sequence of its top-level children. Then for each node in the resulting sequence, a new deep copy of the node is constructed, including its children and attributes. Each copied node has a new node identity. Copied element nodes are given the type annotation *xdt:untyped*, and copied attribute nodes are given the type annotation *xdt:untypedAtomic*. For each adjacent sequence of one or more atomic values that are returned in the sequence, a new text node is constructed that contains the result of casting each atomic value to a string, with a single blank character inserted between adjacent values. If any of these atomic values cannot be cast into a string, an error is returned.
4. The result sequence of *xml:attributes-function* and the resulting sequences of all *element-content-expression* clauses are concatenated into one sequence which is called the *content sequence*. Any sequence of adjacent text nodes in the content sequence is merged into a single text node by concatenating their contents, with no intervening blanks. After concatenation, any text node that is a zero-length string is deleted from the content sequence.
5. If the content sequence contains an attribute node that follows a node that is not an attribute node, an error is returned. Attribute nodes that occur in the content sequence become attributes of the new element node. If two or more of these attribute nodes have the same name, an error is returned. A namespace declaration is created that corresponds to any namespace that is used in the names of the attribute nodes if the namespace URI is not in the in-scope namespaces of the constructed element.
6. Element, text, comment, and processing instruction nodes in the content sequence become the children of the constructed element node.
7. The constructed element node is given a type annotation of *xdt:untyped*, and each of its attributes is given a type annotation of *xdt:untypedAtomic*. The node name of the constructed element node is the XML element name that is specified after the NAME keyword.

Rules for using namespaces within XMLELEMENT:

The following rules describe scoping of namespaces:

- The namespaces that are declared in the XMLNAMESPACES function are the in-scope namespaces of the element node that are constructed by the XMLELEMENT function. If the element node is serialized, each of its in-scope namespaces will be serialized as a namespace attribute unless it is an in-scope namespace of the parent of the element node and the parent element is also serialized.
- The scope of these namespaces is the lexical scope of the XMLELEMENT function, including the element name, the attribute names that are specified in the XMLATTRIBUTES function, and all *element-content-expressions*. These are used to resolve the QNames in the scope.
- If an XMLQUERY or XMLEXISTS function is in an *element-content-expression*, the namespaces become the *statically known namespaces* of the XQuery expression of the XMLQUERY or XMLEXISTS function. Statically known namespaces are used to resolve the QNames that are in the XQuery expression. If the XQuery prolog declares a namespace that has the same prefix within the scope of the XQuery expression, the namespace that is declared in the prolog will override the namespaces that are declared in the XMLNAMESPACES function.
- If an attribute of the constructed element comes from *element-content-expression*, its namespace might not already be declared as an in-scope namespace of the constructed element. In this case, a new namespace is created for it. If the prefix of the attribute name is already bound to a different

URI by an in-scope namespace, Db2 generates a different prefix to be used in the attribute name. A namespace is created for this generated prefix. The name of the generated prefix follows the following pattern: db2ns-xx, where xx is a pair of characters chosen from the set [A-Z,a-z,0-9].

Examples

Example 1:

The following statement uses the XMLLEMENT function to create an XML element that contains an employee's name. The statement also stores the employee number as an attribute named serial. If there is a null value in the referenced column, the function returns the null value:

```
SELECT e.empno, e.firstnme, e.lastname,
       XMLLEMENT ( NAME "foo:Emp",
                   XMLNAMESPACES('http://www.foo.com' AS "foo"),
                   XMLATTRIBUTES(e.empno as "serial"),
                   e.firstnme,
                   e.lastname
                   OPTION NULL ON NULL ) AS "Result"
FROM EMP e
WHERE e.edlevel = 12;
```

The result of the query would look similar to the following result:

EMPNO	FIRSTNME	LASTNAME	Result
A0001	John	Parker	<foo:Emp xmlns:foo="http://www.foo.com" serial="A0001">JohnParker</foo:Emp>
B0001	(null)	Smith	<foo:Emp xmlns:foo="http://www.foo.com" serial="B0001">Smith</foo:Emp>
B0002	(null)	(null)	(null)
(null)	(null)	(null)	(null)

Example 2:

The following example is similar to Example 1, however, when a null value is in one of the referenced columns, an empty element is returned:

```
SELECT e.empno, e.firstnme, e.lastname,
       XMLLEMENT (NAME "foo:Emp",
                   XMLNAMESPACES('http://www.foo.com' AS "foo"),
                   XMLATTRIBUTES(e.empno as "serial"),
                   e.firstnme,
                   e.lastname
                   OPTION EMPTY ON NULL) AS "Result"
FROM EMP e
WHERE e.edlevel = 12;
```

The result of the query would look similar to the following result:

EMPNO	FIRSTNME	LASTNAME	Result
A0001	John	Parker	<foo:Emp xmlns:foo="http://www.foo.com" serial="A0001">JohnParker</foo:Emp>
B0001	(null)	Smith	<foo:Emp xmlns:foo="http://www.foo.com" serial="B0001">Smith</foo:Emp>
B0002	(null)	(null)	<foo:Emp xmlns:foo="http://www.foo.com" serial="B0002"/>
(null)	(null)	(null)	<foo:Emp xmlns:foo="http://www.foo.com"/>

XMLFOREST scalar function

The XMLFOREST function returns an XML value that is a sequence of XML element nodes.

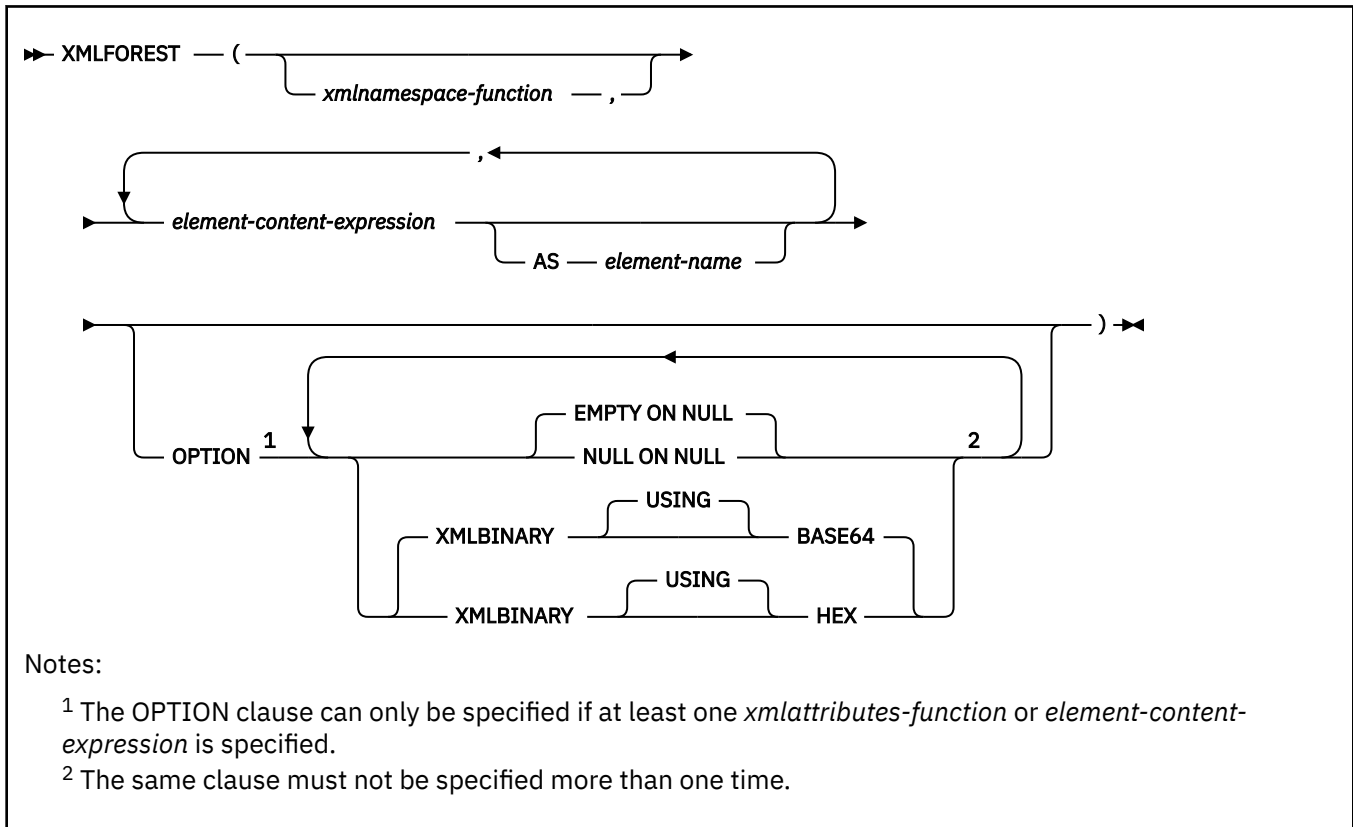

The schema is SYSIBM.

xmlnamespace-function

Specifies the XML namespace declarations that are the result of the XMLNAMESPACES function. The namespaces that are declared are in the scope of the XMLFOREST function. The namespaces apply to any nested XML functions within the XMLFOREST function, regardless of whether or not those functions appear inside another subselect. See “XMLNAMESPACES scalar function” on page 656 for more information on declaring XML namespaces.

If *xmlnamespace-function* is not specified, namespace declarations are not associated with the constructed sequence of XML element nodes.

element-content-expression

Specifies an expression that returns a value that is used for the content of a generated XML element. The result of the expression is mapped to an XML value according to the mapping rules from an SQL value to an XML value. If the expression is not a simple column reference, *element-name* must be specified.

AS *element-name*

Specifies an identifier that is used for the XML element name.

An XML element name must be an XML QName. If the name is qualified, the namespace prefix must be declared within the scope.

If *element-name* is not specified, *element-content-expression* must be a column name. The element name is created from the column name using the fully escaped mapping from a column name to a QName.

OPTION

Specifies options for the result for NULL values, binary data, and bit data. The options will not be inherited by the XMLELEMENT or XMLFOREST functions that appear in *element-content-expression*.

EMPTY ON NULL or NULL ON NULL

Specifies if a null value or an empty element is returned when the values of each *element-content-expression* is a null value. EMPTY ON NULL and NULL ON NULL only affect null handling of the *element-content-expression* arguments, not the handling of values from an *xmlattributes-function* argument.

EMPTY ON NULL

If the value of each *element-content-expression* is null, an empty element is returned.

EMPTY ON NULL is the default.

NULL ON NULL

If the value of each *element-content-expression* is null, a null value is returned.

XMLBINARY USING BASE64 or XMLBINARY USING HEX

Specifies the assumed encoding of binary input data, character string data with the FOR BIT DATA attribute, ROWID, or a distinct type that is based on one of these types. The encoding applies to element content or attribute values.

XMLBINARY USING BASE64

Specifies that the assumed encoding is base64 characters, as defined for XML schema type `xs:base64Binary` encoding. The base64 encoding uses a 64-character subset of US-ASCII (10 digits, 26 lowercase characters, 26 uppercase characters, '+' and '/') to represent every 6 bits of the binary or bit data by one printable character in the subset. These characters are selected so that they are universally representable. In addition, the '=' character represents a line pad character. Using this method, the size of the encoded data is 33 percent larger than the original binary or bit data.

XMLBINARY USING BASE64 is the default.

XMLBINARY USING HEX

Specifies that the assumed encoding is hexadecimal characters, as defined for XML schema type `xs:hexBinary` encoding. The hex encoding represents each byte (8 bits) with two hexadecimal characters. Using this method, the encoded data is twice the size of the original binary or bit data.

The XMLFOREST function can be expressed using the XMLCONCAT and XMLELEMENT functions.

This function takes an optional set of namespace declarations and one or more arguments that make up the name and element content for one or more element nodes. The result is an XML sequence containing a sequence of element nodes or the null value.

The result of the function is an XML value. The result can be null; if all the *element-content-expression* arguments are null and the NULL ON NULL option is in effect, the result is the null value.

Example: Generate an Emp element for each employee in the sample EMP table who was hired in 1980 or later. Concatenate the values of columns FIRSTNAME and LASTNAME to form the Name attribute of the Emp element. Use XMLFOREST to create two nested elements of the Emp element: The Hiredate element and the Department element. The Hiredate element value is the HIREDATE column value. The Department element value is the WORKDEPT column value.

```
SELECT e.EMPNO AS "ID",
       XMLSERIALIZE(
         XMLELEMENT(
           NAME "Emp",
           XMLATTRIBUTES(e.FIRSTNAME || ' ' || e.LASTNAME AS "Name"),
           XMLFOREST(e.HIREDATE AS "Hiredate",e.WORKDEPT AS "Department"))
         AS CLOB(100))
       AS "Result"
FROM EMP e
WHERE YEAR(HIREDATE)>='1980';
```

The query returns results similar to these:

ID	Result
000070	<Emp Name="EVA PULASKI"> <Hiredate>1980-09-30</Hiredate>

```

    <Department>D21</Department>
  </Emp>
000100 <Emp Name="THEODORE SPENSER">
    <Hiredate>1980-06-19</Hiredate>
    <Department>E21</Department>
  </Emp>
000270 <Emp Name="MARIA PEREZ">
    <Hiredate>1980-09-30</Hiredate>
    <Department>D21</Department>
  </Emp>
000290 <Emp Name="JOHN PARKER">
    <Hiredate>1980-05-30</Hiredate>
    <Department>E11</Department>
  </Emp>

```

XMLMODIFY scalar function

The XMLMODIFY function returns an XML value that might have been modified by the evaluation of an XQuery updating expression and XQuery variables that are specified as input arguments.

►► XMLMODIFY (— *xquery-update-constant* →

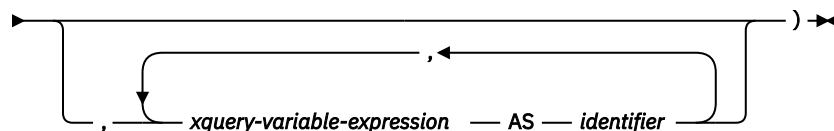

The schema is SYSIBM.

xquery-update-constant

Specifies an SQL character string constant that is interpreted as an XQuery updating expression that uses supported XQuery language syntax. *xquery-update-constant* must be one of the following items:

- An insert expression.
- A delete expression.
- A replace expression.
- A FLWOR expression that contains an updating expression in its return clause.
- A conditional expression that contains an updating expression in its then or else clause.
- A sequence expression that contains two or more updating expressions, separate by commas. All operands are either updating expressions or an empty sequence.

xquery-update-constant must not be an empty string or a string of all blanks.

xquery-variable expression

xquery-variable-expression specifies an SQL expression whose value is available to the XQuery expression that is specified by *xquery-update-constant* during execution.

The data type of *xquery-variable-expression* can be XML, integer, decimal, or a character or graphic string that is not a LOB. *xquery-variable-expression* must not return a ROWID, TIMESTAMP, binary string, REAL, DECFLOAT data types, or a character string that is bit data, and *xquery-variable-expression* must not reference a sequence expression. If the result value is of type XML, it is passed by reference, which means that the original values, not copies, are used in the evaluation of the XQuery expression. A null XML value is converted to an XML empty sequence. If the resulting value is not of type XML, the result of the expression must be castable to an XML value. A null value is converted to an XML empty sequence. The non-XML values creates a new copy of the value during the cast to XML.

An XQuery variable is created for each *xquery-variable-expression* this is specified, and the XQuery variable is set to a value that is equal to the *input-xml-value*.

AS identifier

Specifies that the value that is generated by *xquery-variable-expression* is passed to *xquery-update-constant* as an XQuery variable named *identifier*. The length of the name must not be longer than 128 bytes. If the length of the name is longer than 128 bytes, an error is returned. The leading dollar sign (\$) that precedes variable names in the XQuery language is not included in *identifier*. The name must be an XML 1.0 NCName that is not the same as the identifier for another *xquery-variable-expression* in the same PASSING clause. If the identifier is not an XML 1.0 NCName an error is returned. If more than one *xquery-variable expression* have the same name, an error is returned. If the result of an *xquery-variable expression* is null, an empty sequence is assigned to the corresponding XQuery variable.

The XMLMODIFY function can only be used in an SQL UPDATE statement or within the update clause of an SQL MERGE statement. The XMLMODIFY function must be the topmost expression on the right hand side of the SET assignment clause of the update.

In an XMLMODIFY invocation, updating expressions cannot modify new nodes that are added by other updating expressions. For example, if an updating expression adds a new element node, another updating expression cannot change the newly created node.

For an XMLMODIFY invocation, the Db2 database manager applies updating expressions in the following order:

1. The following operations, in a non-deterministic order:
 - Insert operations that do not use ordering keywords, such as before, after, as first, or as last
 - Replace operations in which the keyword value of is specified, and the target node is an attribute node, text node, comment node, or processing instruction node
2. Insert operations that use ordering keywords such as before, after, as first, or as last
3. Replace operations in which the keyword value of is not specified
4. Replace operations in which the keyword value of is specified, and the target node is an element node
5. All delete operations

The *target-xml-column* is the XML column in the SET assignment clause that is to be updated by the value that is returned by the XMLMODIFY function. The initial context item in the XQuery updating expression is the value of the *target-xml-column* that is passed by reference. Only the value of the *target-xml-column* can be modified by the XQuery updating expression. In other words, the target expression nodes in the XQuery updating expression must be a node in the value of *target-xml-column*. The *target-xml-column* must be an XML column that is defined in the XML versioning format.

The value of *target-xml-column* that is modified by the XQuery updating expression is returned by the function. If the value of *target-xml-column* is null, the function returns null. Otherwise, the result of the XMLMODIFY function must be a well-formed XML document. If the XQuery updating expressions makes no modifications to the value of *target-xml-column*, the unmodified XML value is returned by the function. The XMLMODIFY function preserves the original node identities and the document order of *target-xml-column*. Although XMLMODIFY modifies *target-xml-column* by reference, for each row that is updated by the SQL UPDATE statement, any reference to *target-xml-column* in the SQL UPDATE statement is the value of the *target-xml-column* before the row is updated.

Example 1: The following is an example of an XMLMODIFY function with an XQuery insert expression. Assume that a table contains a column named PO that contains an XML document, 'purchaseOrders':

```
UPDATE purchaseOrders
SET PO = XMLMODIFY('declare namespace ipo="http://www.example.com/IPO";
declare namespace pyd="http://www.examplepayment.com";
insert node $payment/@pyd:paidDate
as first into /ipo:purchaseOrder/billTo',
XMLPARSE(DOCUMENT
'<payment xmlns:pyd="http://
www.examplepayment.com"
pyd:paidDate="2000-01-07">278.94
</payment>') AS "payment")
```

The result of the purchaseOrders XML document in the PO column is as follows:

```
<ipo:purchaseOrder
  xmlns:xsi="http://www.w3.org/2001/XMLSchema-instance"
  xmlns:ipo="http://www.example.com/IPO"
  xmlns:pyd="http://www.examplepayment.com"
  orderDate="1999-12-01" pyd:paidDate="2000-01-07">
  <shipTo exportCode="1" xsi:type="ipo:UKAddress">
  <name>Helen Zoe</name>
    <street>47 Eden Street</street>
    <city>Cambridge</city>
    <postcode>CB1 1JR</postcode>
  </shipTo>
  .
  .
</ipo:purchaseOrder>
```

Example 2: Assume that table PURCHASEORDER contains a column named PORDER that contains the following XML document:

```
<ipo:purchaseOrder
  xmlns:xsi="http://www.w3.org/2001/XMLSchema-instance"
  xmlns:ipo="http://www.example.com/IPO"
  xmlns:pyd="http://www.examplepayment.com"
  orderDate="1999-12-01" pyd:paidDate="2000-01-07">
  <shipTo exportCode="1" xsi:type="ipo:UKAddress">
  <name>Helen Zoe</name>
  <street>47 Eden Street</street>
  <city>Cambridge</city>
  <postcode>CB1 1JR</postcode>
  </shipTo>
  <items>
  <item partNum="872-AA">
  <productName>Lawnmower</productName>
  <quantity>1</quantity>
  <USPrice>149.99</USPrice>
  <shipDate>2011-05-20</shipDate>
  </item>
  <item partNum="945-ZG">
  <productName>Sapphire Bracelet</productName>
  <quantity>2</quantity>
  <USPrice>178.99</USPrice>
  <comment>Not shipped</comment>
  </item>
  </items>
</ipo:purchaseOrder>
```

The following is an example of an XMLMODIFY function with an XQuery replace expression and an XQuery delete expression.

```
UPDATE PURCHASEORDER
SET PORDER = XMLMODIFY(
  'declare namespace ipo="http://www.example.com/IPO";
  replace value of node /ipo:purchaseOrder/items/item[@partNum="872-AA"]/quantity
  with xs:integer(2),
  delete node /ipo:purchaseOrder/items/item[@partNum="945-ZG"]');
```

After the UPDATE statement executes, the result is as follows:

```
<ipo:purchaseOrder
  xmlns:xsi="http://www.w3.org/2001/XMLSchema-instance"
  xmlns:ipo="http://www.example.com/IPO"
  xmlns:pyd="http://www.examplepayment.com"
  orderDate="1999-12-01" pyd:paidDate="2000-01-07">
  <shipTo exportCode="1" xsi:type="ipo:UKAddress">
  <name>Helen Zoe</name>
  <street>47 Eden Street</street>
  <city>Cambridge</city>
  <postcode>CB1 1JR</postcode>
  </shipTo>
  <items>
  <item partNum="872-AA">
  <productName>Lawnmower</productName>
  <quantity>2</quantity>
  <USPrice>149.99</USPrice>
```

```

    <shipDate>2011-05-20</shipDate>
  </item>
</items>
</ipo:purchaseOrder>

```

Related concepts

[Basic updating expressions \(Db2 Programming for XML\)](#)

XMLNAMESPACES scalar function

The XMLNAMESPACES function constructs namespace declarations from the arguments. This function can be used as an argument only for specific functions, such as the XMLELEMENT function and the XMLFOREST function.

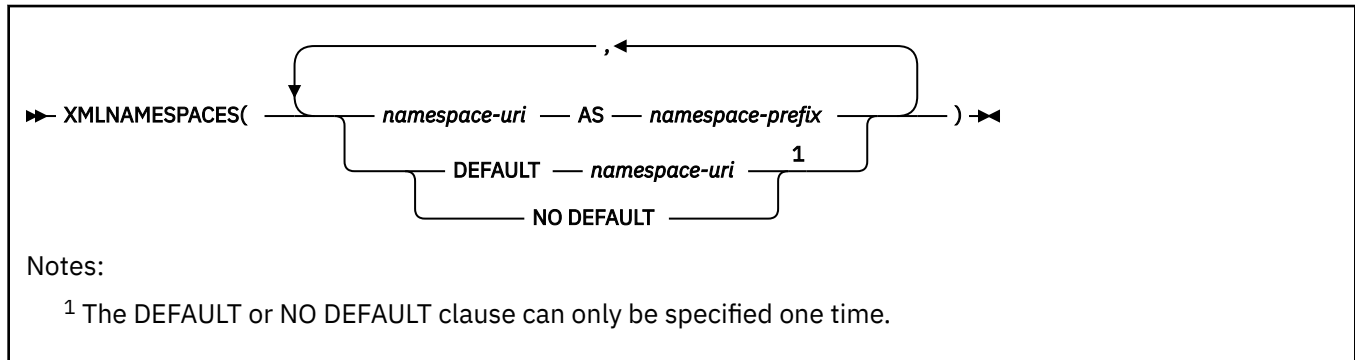

The schema is SYSIBM.

The result is one or more XML namespace declarations containing in-scope namespaces for each non-null input value.

namespace-uri

Specifies an SQL character string constant that contains the namespace name or a universal resource identifier (URI). The character string constant must not be an empty string if it is used with *namespace-prefix*. *namespace-uri* cannot be `http://www.w3.org/XML/1998/namespace` or `http://www.w3.org/2000/xmlns/`.

AS namespace-prefix

Specifies a namespace prefix. The prefix is an SQL identifier that must be in the form of an XML NCName. The prefix must not be "xml" or "xmlns". The prefix must be unique within the list of namespace declarations.

The following namespace prefixes are pre-defined in SQL/XML: "xml", "xs", "xsd", "xsi", and "sqlxml". Their bindings are:

- `xmlns:xml = "http://www.w3.org/XML/1998/namespace"`
- `xmlns:xs = "http://www.w3.org/2001/XMLSchema"`
- `xmlns:xsd = "http://www.w3.org/2001/XMLSchema"`
- `xmlns:xsi = "http://www.w3.org/2001/XMLSchema-instance"`
- `xmlns:sqlxml = "http://standards.iso.org/iso/9075/2003/sqlxml"`

DEFAULT namespace-uri or NO DEFAULT

Specifies whether a default namespace is to be used within the scope of this namespace declaration.

The scope of this namespace declaration is the specified XML element and all XML expressions that are contained in the specified XML element.

DEFAULT namespace-uri

Specifies the default namespace to use within the scope of this namespace declaration. The *namespace-uri* applies for unqualified names in the scope unless it is overridden in a nested scope by another DEFAULT declaration or by a NO DEFAULT declaration.

namespace-uri specifies an SQL character string constant that contains a namespace name or universal resource identifier (URI). The character string constant can be an empty string in the context of the DEFAULT clause.

NO DEFAULT

Specifies that no default namespace is to be used within the scope of this namespace declaration. There is no default namespace in the scope unless the NO DEFAULT clause is overridden in a nested scope by a DEFAULT declaration.

The result of the function is an XML value that is an XML sequence that contains an XML namespace declaration for each specified namespace. The result cannot be null.

Example 1: Generate an "employee" element for each employee. The employee element is associated with XML namespace "urn:bo", which is bound to prefix "bo". The element contains attributes for names and a hiredate subelement.

```
SELECT e.empno, XMLSERIALIZE(XMLELEMENT(NAME "bo:employee",
                                     XMLNAMESPACES('urn:bo' as "bo"),
                                     XMLATTRIBUTES(e.lastname, e.firstname),
                                     XMLELEMENT(NAME "bo:hiredate", e.hiredate)) AS CLOB(50))
FROM employee e where e.edlevel = 12;
```

The result of the query would be similar to the following result:

```
00029 <bo:employee xmlns:bo="urn:bo" LASTNAME="PARKER" FIRSTNAME="JOHN">
      <bo:hiredate>198-5-3</bo:hiredate>
</bo:employee>
00031 <bo:employee xmlns:bo="urn:bo" LASTNAME="SETRIGHT"
      FIRSTNAME="MAUDE">
      <bo:hiredate>1964-9-12</bo:hiredate>
</bo:employee>
```

Example 2: Generate two elements for each employee using XMLFOREST. The first "lastname" element is associated with the default namespace "http://hr.org", and the second "job" element is associated with XML namespace "http://fed.gov", which is bound to prefix "d".

```
SELECT empno, XMLSERIALIZE(XMLFOREST(
    XMLNAMESPACES(DEFAULT 'http://hr.org', 'http://fed.gov' AS "d"),
    lastname, job AS "d:job") AS CLOB(50))
FROM employee where edlevel = 12;
```

The result of the query would be similar to the following result:

```
00029 <LASTNAME xmlns="http://hr.org" xmlns:d="http://fed.gov">PARKER
</LASTNAME>
      <d:job xmlns="http://hr.org" xmlns:d="http://fed.gov">
OPERATOR</d:job>
00031 <LASTNAME xmlns="http://hr.org" xmlns:d="http://fed.gov">
      SETRIGHT</LASTNAME>
      <d:job xmlns="http://hr.org" xmlns:d="http://fed.gov">
OPERATOR</d:job>
```

XMLPARSE scalar function

The XMLPARSE function parses the argument as an XML document and returns an XML value.

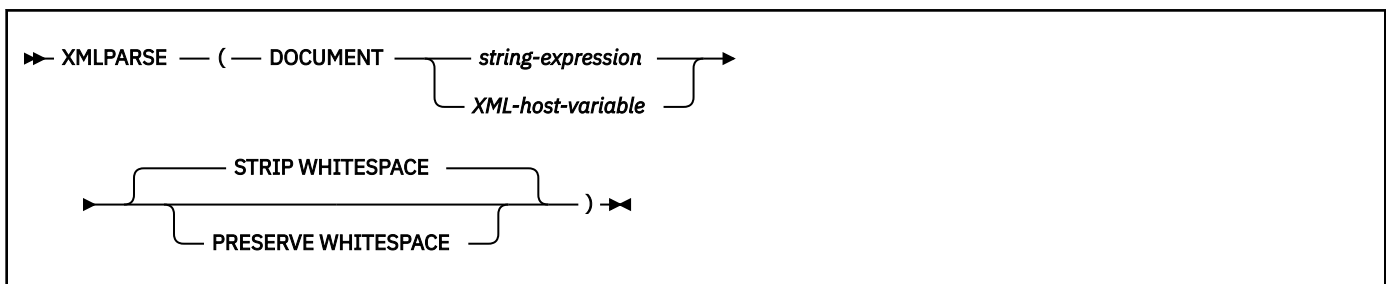

The schema is SYSIBM.

DOCUMENT

Specifies that the character string expression to be parsed must evaluate to a well-formed XML document that conforms to XML 1.0.

string-expression

An expression that returns a character, graphic, or binary string.

string-expression must evaluate to a character string that conforms to the definition of a well-formed XML document as defined in XML 1.0.

XML-host-variable

An XML host variable that contains a well-formed XML document as defined in XML 1.0. *XML-host-variable* must not be binary XML data.

STRIP WHITESPACE or PRESERVE WHITESPACE

Specifies whether whitespace is to be removed or preserved. Any DTD attributes for `xml:space` have no impact on whitespace handling.

STRIP WHITESPACE

Specifies that whitespace (space that is between element nodes without any non-whitespace text nodes) will be stripped unless the nearest containing element has a value of 'preserve' for the `xml:space` attribute.

STRIP WHITESPACE is the default.

PRESERVE WHITESPACE

Specifies that all whitespace is preserved, even when the nearest containing element has a value of 'default' for the `xml:space` attribute.

The result of the function is XML. If *string-expression* can be null, the result can be null; if *string-expression* is null, the result is the null value.

Notes

Direct use of XMLPARSE with character string input:

Applications should avoid direct use of the XMLPARSE function with character string input and should send strings that contain XML documents directly by using host variables to maintain the match between the external encoding and the encoding in the XML declaration. If XMLPARSE must be used in this situation, a BLOB type should be specified as the argument to avoid code page conversion.

Examples

Example 1:

The following example inserts an XML document into the EMP table and preserves the whitespace in the original XML document. Assume that *hv* contains the value, '`<a xml:space='preserve'> <c>c</c>b `':

```
INSERT INTO EMP (id, xvalue) VALUES(1001,
                                   XMLPARSE(DOCUMENT :hv
                                             PRESERVE WHITESPACE));
```

XMLPARSE will treat the value in *hv* for the insert statement as equivalent to the following value:

```
<a xml:space='preserve'> <b> <c>c</c>b </b>
</a>
```

Example 2:

The following example inserts an XML document into the EMP table and strips the whitespace in the original XML document. Assume that *hv* contains the value, '`<a xml:space='preserve'> <b xml:space='default'> <c>c</c>b `':

```
INSERT INTO EMP (id, xvalue) VALUES(1001,
                                   XMLPARSE(DOCUMENT :hv
                                             STRIP WHITESPACE));
```

XMLPARSE will treat the value in *hv* for the insert statement as equivalent to the following value:

```
<a xml:space='preserve'>
<b xml:space='default'><c>c</c>b </b>
</a>
```

XMLPI scalar function

The XMLPI function returns an XML value with a single processing instruction node.

► XMLPI (— NAME — *pi-name* — , — *string-expression*) ◄

The schema is SYSIBM.

NAME *pi-name*

Specifies the name of a processing instruction. The name is an SQL identifier that must be in the form of an XML NCName. The name must not contain "xml" in any case combination.

string-expression

An expression that returns a value of a built-in character or graphic string that is not a LOB and is not bit data. The resulting string will be converted to UTF-8 and parsed to check for conformance to the content of XML processing instruction as specified by the following rules:

- The string must not contain the substring '>' as this terminates a processing instruction.
- Each character can be any Unicode character, excluding the surrogate blocks, X'FFFE', and X'FFFF'.

If the resulting string does not conform to the preceding rules, an error is returned. The resulting string becomes the contents of the constructed processing instruction node. If *string-expression* is not specified or is an empty string, the contents of the processing instruction node are empty.

The result of the function is an XML value. The result can be null; if the *string-expression* argument is null, the result is the null value.

Example: Generate an XML processing instruction node:

```
SELECT XMLPI(NAME "Instruction", 'Push the red button')
FROM SYSIBM.SYSDUMMY1;
```

The result looks similar to the following results:

```
<?Instruction Push the red button?>
```

XMLQUERY scalar function

The XMLQUERY function returns an XML value from the evaluation of an XQuery expression, by using specified input arguments, a context item, and XQuery variables.

► XMLQUERY (— *xquery-expression-constant* —) ◄

PASSING — BY REF — *xquery-argument* 1 —

RETURNING SEQUENCE — BY REF — EMPTY ON EMPTY —) ◄

Notes:

¹ *xquery-context-item-expression* must not be specified more than one time.

xquery-argument:

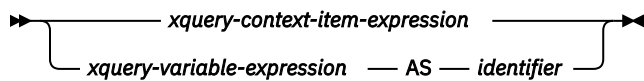

The schema is SYSIBM.

xquery-expression-constant

Specifies an SQL character string constant that is interpreted as an XQuery expression using supported XQuery language syntax. For information about the supported XQuery expressions, see [XQuery prologs and expressions \(Db2 Programming for XML\)](#). *xquery-expression-constant* cannot be an XQuery updating expression. The XQuery expression is evaluated with the arguments specified in *xquery-argument*, and returns an output sequence that is also returned as the result of the XMLQUERY function. *xquery-expression-constant* must not be an empty string or a string of all blanks.

PASSING

Specifies input values and the manner in which these values are passed to the XQuery expression that is specified by *xquery-expression-constant*.

BY REF

Specifies that the XML input value arguments are to be passed by reference. When XML values are passed by reference, the XQuery evaluation uses the input node trees which preserves all properties, including the original node identities and document order. If two arguments pass the same XML value, node identity comparisons and document ordering comparisons involving some nodes that are contained between the two input arguments might refer to nodes that are within the same XML node tree.

BY REF has no impact on how non-XML values are passed. The non-XML values create a new copy of the value during the cast to XML.

xquery-argument

Specifies an argument that is passed to the XQuery expression that is specified by *xquery-expression-constant*. A query argument is an expression that returns a value that is XML, integer, decimal, or a character or graphic string that is not a LOB. *xquery-argument* must not return ROWID, TIMESTAMP, binary string, REAL, DECFLOAT data types, or a character string data type that is bit data, and must not reference a sequence expression.

xquery-argument specifies both a value and the manner in which that value is to be passed.

How an argument in the PASSING clause is used in the XQuery expression depends on whether the argument is specified as *xquery-context-item-expression* or *xquery-variable-expression*. *xquery-argument* includes an SQL expression that is evaluated before passing the result to the XQuery expression.

- If the resulting value is of type XML, it becomes an *input-xml-value*. It is passed by reference, which means that the original values, not copies, are used in the evaluation of the XQuery expression. A null XML value is converted to an XML empty sequence.
- If the resulting value is not of type XML, the result of the expression must be able to be cast to an XML value. A null value is converted to an XML empty sequence. The converted value becomes an *input-xml-value*.

When *xquery-expression-constant* is evaluated, an XQuery variable receives a value that is equal to *input-xml-value* and a name as specified by the AS clause.

xquery-context-item-expression

xquery-context-item-expression specifies the initial context item in the XQuery expression specified by *xquery-expression-constant*. The value of the initial context item is the result of

xquery-context-item-expression cast to XML. *xquery-context-item-expression* must not be specified more than one time.

xquery-context-item-expression must not be a sequence of more than one item. If *input-xml-value* is an empty XML string, the XQuery expression is evaluated with the initial context item set to an empty XML string. If the value of *input-xml-value* is null, the function returns a null value.

If the *xquery-context-item-expression* is not specified or is an empty sequence, the initial context item in the XQuery expression is undefined and the XQuery expression must not reference the initial context item.

An XQuery variable is not created for the context item expression.

xquery-variable-expression

xquery-variable-expression specifies an SQL expression whose value is available to the XQuery expression that is specified by *xquery-expression-constant* during execution. The sequence cannot contain a sequence reference.

An XQuery variable is created for each *xquery-variable-expression*, and the XQuery variable is set to a value equal to *input-xml-value*. For example, `PASSING T.A + T.B AS "sum"` creates an XQuery variable named `sum`. The scope of the XQuery variables that are created from the `PASSING` clause is the XQuery expression that is specified by *xquery-expression-constant*.

AS identifier

Specifies that the value that is generated by *xquery-variable-expression* is passed to *xquery-expression-constant* as an XQuery variable named *identifier*. The length of the name must not be longer than 128 bytes. The leading dollar sign (\$) that precedes variable names in the XQuery language is not included in *identifier*. The name must be an XML 1.0 NCName that is not the same as the identifier for another *xquery-variable-expression* in the same `PASSING` clause.

RETURNING SEQUENCE

Specifies that the XQuery expression returns a sequence.

BY REF

Specifies that the result of the XQuery expression is returned by reference. If this value contains nodes, any expression that is using the return value of the XQuery expression will receive node references directly, preserving all node properties including the original node identities and document order.

EMPTY ON EMPTY

Specifies that an empty sequence that results from processing the XQuery expression is returned as an empty sequence.

The result of the function is an XML value, and the result can be null. For example, if *xquery-context-item-expression* is specified and if its value is null, the result of the function is the null value.

If the evaluation of the XQuery expression results in an error, the `XMLQUERY` function returns the XQuery error.

Notes

Implicit casting of a non XML value to an XML value:

If the result of *xquery-argument* is not an XML type, the value is cast to XML as follows. The SQL data type of the expression is mapped to a corresponding XML Schema data type according to the following table:

Table 101. SQL data types and corresponding XML schema data types

SQL data type	XML schema data type
CHAR, VARCHAR	xs:string
GRAPHIC, VARGRAPHIC	xs:string
SMALLINT	xs:integer

Table 101. SQL data types and corresponding XML schema data types (continued)

SQL data type	XML schema data type
INTEGER	xs:integer
BIGINT	xs:integer
DECIMAL	xs:decimal
DOUBLE	xs:double
FLOAT	xs:double

Let V be the value of the expression. An atomic value of the corresponding XML schema data type is constructed such that the result of `cast (V as varchar)` is a lexical representation of the constructed atomic value. For example, an SQL VARCHAR value '123' is converted to an atomic value '123' of xs:string type. An SQL integer '12' is converted to an atomic value '12' of xs:integer. An SQL decimal value '1.20' is converted to an atomic value '1.2' of xs:decimal.

Examples

Example 1:

The following example returns an XML value from evaluation of the specified XQuery expression:

```
SELECT XMLQUERY('//item[productName=$n]'
                PASSING PO.POrder,
                :hv AS "n") AS "Result"
FROM PurchaseOrders PO;
```

Assume that the value of the host variable *hv* is 'Baby Monitor', the result is similar to the following results:

```
Result
-----
<item partNum="926-AA"><productName>Baby Monitor</productName><quantity>1
</quantity><USPrice>39.98</USPrice><shipDate>1999-05-21</shipDate></item>
```

XMLSERIALIZE scalar function

The XMLSERIALIZE function returns a serialized XML value of the specified data type that is generated from the first argument.

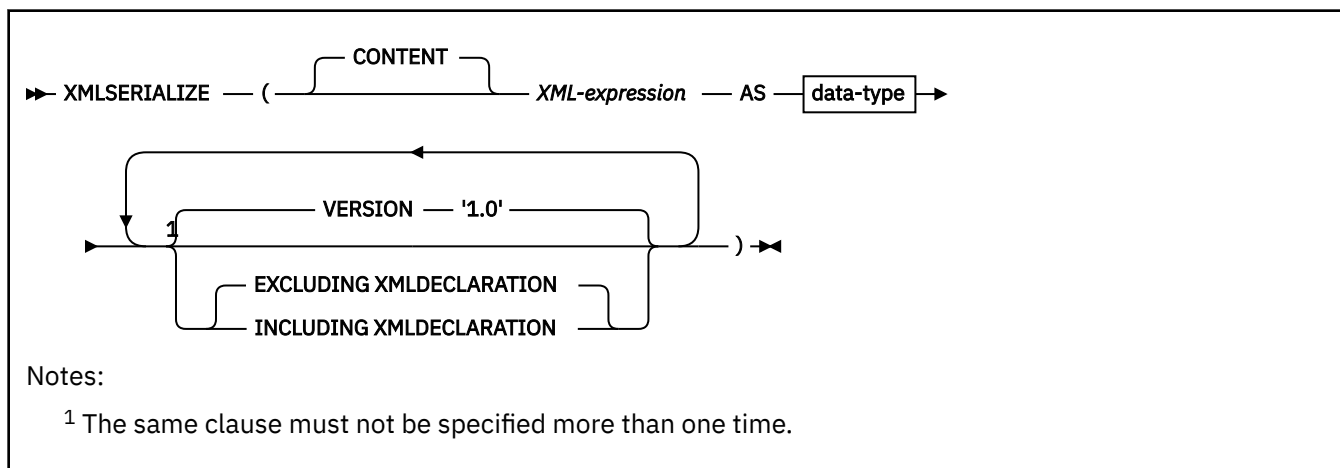

data-type

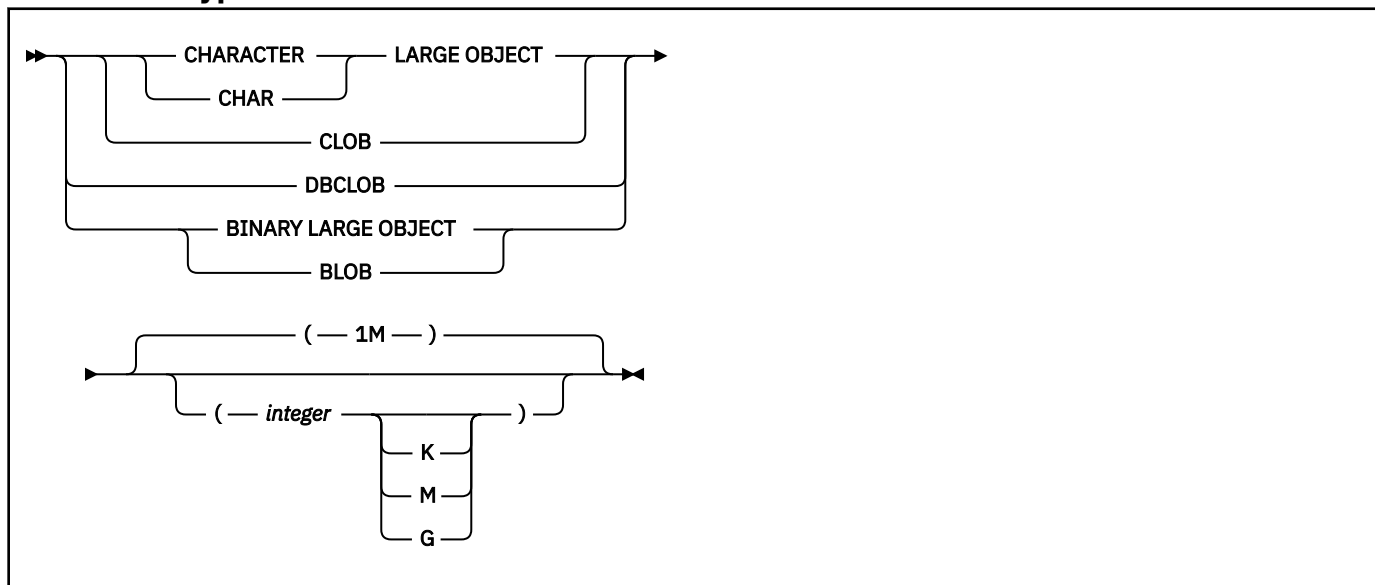

The schema is SYSIBM.

CONTENT

Specifies that any XML value can be specified and the result of the serialization is based on this input value.

XML-expression

An expression that returns an XML value that is not an attribute node. The atomic values in the input sequence must be able to be cast to `xs:string`. *XML-expression* is the input to the serialization process.

AS data type

Specifies the data type of the result. The implicit or explicit length attribute for the specified result data type must be sufficient to contain the serialized output.

The CCSID of a resulting character or graphic string is determined by the data type of the result:

- If the result is a CLOB, the CCSID for mixed Unicode data (1208).
- If the result is a DBCLOB, the CCSID for graphic Unicode data (1200).

VERSION '1.0'

Specifies the XML version of the serialized value. The only version that is supported is '1.0', which must be specified as a string constant.

EXCLUDING XMLDECLARATION or INCLUDING XMLDECLARATION

Specifies whether an XML declaration is included in the result.

EXCLUDING XMLDECLARATION

Specifies that an XML declaration is not included in the result.

EXCLUDING XMLDECLARATION is the default.

INCLUDING XMLDECLARATION

Specifies that an XML declaration is included in the result. The XML declaration contains values for XML serialization version 1.0 and an encoding specification of UTF-8. An XML sequence is effectively converted to have a single document node by applying the XMLDOCUMENT function to *XML-expression* prior to serializing the resulting XML nodes.

The data type and length attribute of the result are determined from the specified *data-type*. The result can be null; if the *XML-expression* argument is null, the result is the null value.

Notes

Serializing a sequence:

The value of the input argument to XMLSERIALIZE is a sequence. Before a sequence is serialized, it is normalized. The purpose of sequence normalization is to create a sequence that can be serialized as a well-formed XML document or external general parsed entity, that also reflects the content of the input sequence to the extent possible. If the input sequence is an XML empty string, the result of serialization is an empty string. Otherwise, the result is constructed as follows:

- For each item in the sequence, if the item is atomic, the lexical representation of the item is obtained by casting it to an xs:string
- Each subsequence of adjacent strings in the sequence is merged into a single string with the values of the adjacent strings separated by a single space.
- For each item in the sequence, if the item is a string, a text node is created with a value that is equal to the string.
- For each node in the sequence, if the node is a document node, it is replaced it by its children.
- Each node must not be an attribute node.
- Each subsequence of adjacent text nodes in the sequence are merged into a single text node that with the values of the adjacent text nodes concatenated in order without a space between each node. Any text nodes of zero length are dropped.
- A document node is created and the sequence of nodes that was generated is copied as the children of the new document node.

Let S be any sequence, the normalization described in the preceding list is equivalent to XMLDOCUMENT(S). Therefore, the following two expressions produce the same result:

- XMLSERIALIZE(S AS CLOB)
- XMLSERIALIZE(XMLDOCUMENT(S) AS CLOB)

Each instance of the following characters that appear in the content of a text node or in the value of an attribute node is mapped as following during serialization:

Character in content of text node	during serialization, the character is mapped to
'&' (X'26')	'&'
'<' (X'3C')	'<'
'>' (X'3E')	'>'
carriage return (X'0D')	''
quote (X'22') ¹	'"'

Note: The quote character is only mapped if it is inside of an attribute value.

Syntax alternatives:

XML2CLOB(*XML-expression*) can be specified as an alternative to XMLSERIALIZE(*XML-expression* AS CLOB(2G)). XML2CLOB is supported only for compatibility with previous releases of Db2.

Examples

Example 1:

Serialize XML values into CLOB(100) values. The XMLELEMENT function generates the XML values from the concatenation of the FIRSTNAME and LASTNAME column values of the sample EMP table.

```
SELECT e.EMPNO as "ID",
XMLSERIALIZE(
  XMLELEMENT(
    NAME "Emp",
    e.FIRSTNAME || ' ' || e.LASTNAME)
```

```
AS CLOB(100))
AS "Result"
FROM EMP e
WHERE LASTNAME LIKE 'P%';
```

The query returns results similar to these:

ID	Result
000070	<Emp>EVA PULASKI</Emp>
000160	<Emp>ELIZABETH PIANKA</Emp>
000270	<Emp>MARIA PEREZ</Emp>
000290	<Emp>JOHN PARKER</Emp>

Example 2:

Serialize XML values into BLOB(1K) values. The XMLELEMENT function generates the XML values from the concatenation of the FIRSTNAME and LASTNAME column values of the sample EMP table.

```
SELECT e.EMPNO as "ID",
XMLSERIALIZE(
  XMLELEMENT(
    NAME "Emp",
    e.FIRSTNAME || ' ' || e.LASTNAME)
  AS BLOB(1K))
AS "Result"
FROM EMP e
WHERE LASTNAME LIKE 'P%';
```

The query returns results similar to these:

ID	Result
000070	3C456D703E4556412050554C41534B493C2F456D703E
000160	3C456D703E454C495A4142455448205049414E4B413C2F456D703E
000270	3C456D703E4D4152494120504552455A3C2F456D703E
000290	3C456D703E4A4F484E205041524B45523C2F456D703E

XMLTEXT scalar function

The XMLTEXT function returns an XML value with a single text node that contains the value of the argument.

► XMLTEXT (— *string-expression* —) ◄

The schema is SYSIBM.

string-expression

An expression that returns a value of a built-in character or graphic string that is not bit data. Any character in the resulting string must be a valid XML 1.0 character when it is converted to UTF-8.

If *string-expression* is an empty string, an empty text node is returned.

The result of the function is an XML value.

The result can be null; if the argument is null, the result is the null value.

Example 1: The following example returns an XML value with a single text node that contains the specified value:

```
SELECT XMLTEXT('The stock symbol for Johnson&Johnson is JNJ.') AS "Result"
FROM SYSIBM.SYSDUMMY1;
```

The result looks similar to the following results:

Result

The stock symbol for Johnson&Johnson is JNJ.

Example 2: The XMLTEXT function enables the XMLAGG function to construct mixed content, as in the following example:

```
SELECT XMLELEMENT(NAME "para",
  XMLAGG(XMLCONCAT( XMLTEXT( plaintext),
    XMLELEMENT( NAME "emphasis",
      emphtext ))
  ORDER BY seqno ), '.' ) as "result"
FROM T;
```

Suppose that the content of the table T is as the following example:

seqno	plaintext	emphtext
1	This query shows how to construct	mixed content
2	using XMLAGG and XMLTEXT. Without	XMLTEXT
3	XMLAGG cannot group text nodes with other nodes, therefore, cannot generate	mixed content

The result looks like the following result:

```
result
-----
<para>This query shows how to construct <emphasis>mixed content</emphasis>
using XMLAGG and XMLTEXT. Without <emphasis>XMLTEXT</emphasis>, XMLAGG
cannot group text nodes with other nodes, therefore, cannot generate
<emphasis>mixed content</emphasis>.</para>
```

XMLXSROBJECTID scalar function

The XMLXSROBJECTID function returns the XSR object identifier of the XML schema that is used to validate the XML document specified in the argument.

►► XMLXSROBJECTID(*xml-value-expression*) ◄◄

The schema is SYSIBM.

xml-value-expression

An expression that results in a value with a data type of XML. The resulting XML value must be an XML sequence with a single item that is an XML document or the null value.

The XSR object identifier is returned as a BIGINT value and provides the key to a single row in the SYSIBM.XSROBJECTS table.

The result can be null; if the argument is null, the result is the null value.

If *xml-value-expression* does not specify a validated XML document, the function returns 0.

Notes

The XML schema that corresponds to an XSR object ID returned by the function might no longer exist, because an XML schema can be dropped without affecting XML values that were validated using that XML schema. Therefore, queries that use the XSR object ID to fetch further XML schema information from the SYSIBM.XSROBJECTS table might return an empty result set.

Examples

Example 1:

Use the XMLXSROBJECTID function in conjunction with the DSN_XMLVALIDATE function to find all XML documents that are not validated in a table and validate them:

```
UPDATE orders
   SET content = dsn_xmlvalidate(content, 'SYSXSR.P01')
   WHERE XMLXSROBJECTID(content) = 0;
```

Example 2:

Use the XMLXSROBJECTID function to find the names and target namespaces of the XML schemas that are used to validate the XML documents in a table:

```
SELECT DISTINCT s.XSROBJECTNAME, s.targetNamespace
   FROM orders o, XSROBJECTS s
   WHERE XMLXSROBJECTID(content) = s.XSROBJECTID;
```

XSLTRANSFORM scalar function

The XSLTRANSFORM function transforms an XML document into a different data format. The output can be any form possible for the XSLT processor, including but not limited to XML, HTML, and plain text.

► XSLTRANSFORM(*xml-document* ,*xsl-stylesheet* ,*xsl-parameters*) ◄

The schema is SYSFUN.

xml-document

An expression that returns a well-formed XML document with a data type of CHAR, VARCHAR, or CLOB(2 MB). The input expression can contain XMLSERIALIZE to serialize an XML data type into a CLOB. The *xml-document* is transformed with the XSL style sheet that is specified in *xsl-stylesheet*. The XML document must at minimum be single-rooted and well-formed.

xsl-stylesheet

An expression that returns a well-formed XML document with a data type of CHAR, VARCHAR, or CLOB(256 KB). The input expression can contain XMLSERIALIZE to serialize an XML data type into a CLOB. The document is an XSL style sheet that conforms to the W3C XSLT Version 1.0 Recommendation. This style sheet is applied to transform the value that is specified in *xml-document*.

xsl-parameters

An expression that returns a well-formed XML document or empty string with a data type of CHAR, VARCHAR, or CLOB(64 KB). The input expression can contain XMLSERIALIZE to serialize an XML data type into a CLOB. The *xsl-parameters* provides parameter values to the XSL style sheet specified in *xsl-stylesheet*. The value of the parameter can be specified as an attribute, or as a text node. If both are specified, the value in the attribute is used. The *xsl-stylesheet* document must have matching param name attribute values. The syntax of the parameter document is as follows:

```
<params xmlns="http://www.ibm.com/XSLTransformParameters">
  <param name="..." value="..."/>
  <param name="...">enter value here</param>
  ...
</params>
```

Important: If *xsl-parameters* are not needed, you still must supply an empty string or the function result is null.

The result of the function is of type CLOB(2 MB).

This user-defined function requires IBM SDK for z/OS, Java Technology Edition Version 6.

This user-defined function uses the XSLT support that is provided by the W3C XSL Transformations V1.0 Recommendation.

Tip: To create your own variation of XSLTRANSFORM, start with the CREATE FUNCTION shown in sample member DSNTESR. Change the function name and size of the definition of the input parameters for your environment.

Example 1: This example illustrates how to use XSLT as a formatting engine in a C program.

```
EXEC SQL BEGIN DECLARE SECTION;
SQL TYPE IS CLOB(2M)    xmldoc;
SQL TYPE IS CLOB(256K) stylesheet;
SQL TYPE IS CLOB(64K)  xslparms;
SQL TYPE IS CLOB(2M)   result;
EXEC SQL END DECLARE SECTION;

EXEC SQL
SET :xmldoc = CLOB('<?xml version="1.0"?><hi>Hello</hi>');

EXEC SQL SET :stylesheet = CLOB( '<?xml version="1.0"?>
<xsl:stylesheet xmlns:xsl="http://www.w3.org/1999/XSL/Transform" version="1.0">
<xsl:output indent="yes"/>
<xsl:param name="parm" select="'World'"/>
<xsl:template match="hi">
  <out>
    <xsl:value-of select="."/ />
    <xsl:text>, </xsl:text>
    <xsl:value-of select="$parm"/>
    <xsl:text>!!!</xsl:text>
  </out>
</xsl:template>
</xsl:stylesheet>');

EXEC SQL SET :xslparms = CLOB(
'<params xmlns="http://www.ibm.com/XSLTransformParameters">
  <param name="parm">Silicon Valley</param>
</params>');

EXEC SQL
SELECT SYSFUN.XSLTRANSFORM(:xmldoc, :stylesheet, :xslparms)
INTO :result FROM SYSIBM.SYSDUMMY1;
```

The XML document is transformed by the XSL style sheet. The result of the transformation is:

```
<?xml version="1.0" encoding="UTF-8"?>
<out>Hello, Silicon Valley!!!</out>
```

Related concepts

[Sample SQL statements for installing Db2-supplied routines \(Db2 Installation and Migration\)](#)

Related tasks

[Additional steps for enabling the function for XSLTRANSFORM routines support \(Db2 Installation and Migration\)](#)

[Defining the WLM environment and JCL startup procedure for the Java language XML schema repository stored procedure \(Db2 Programming for XML\)](#)

Related information

[XSL Transformations \(XSLT\)](#)

YEAR scalar function

The YEAR function returns the year part of a value that is a character or graphic string. The value must be a valid string representation of a date or timestamp.

►► YEAR(*expression*) ◀◀

The schema is SYSIBM.

The argument must be an expression that returns one of the following built-in data types: a date, a timestamp, a character string, a graphic string, or a numeric data type.

- If *expression* is a character or graphic string, it must not be a CLOB or DBCLOB, and its value must be a valid string representation of a date or timestamp with an actual length of not greater than 255 bytes.

For the valid formats of string representations of dates and timestamps, see [“String representations of datetime values”](#) on page 120.

- If *expression* is a number, it must be a date or timestamp duration. For the valid formats of date and timestamp durations, see [“Datetime operands”](#) on page 169.

If *expression* is a timestamp with a time zone, or a valid string representation of a timestamp with a time zone, the result is determined from the UTC representation of the datetime value.

The result of the function is a large integer.

The result can be null; if the argument is null, the result is the null value.

The other rules depend on the data type of the argument specified:

If the argument is a date, a timestamp, or a string representation of either, the result is the year part of the value, which is an integer in the range 1–9999.

If the argument is a date duration or a timestamp duration, the result is the year part of the value, which is an integer between -9999 and 9999. A nonzero result has the same sign as the argument.

If the argument contains a time zone, the result is the year part of the value expressed in UTC.

Example 1: From the table DSN8C10.EMP, select all rows for employees who were born in 1941.

```
SELECT *
FROM DSN8C10.EMP
WHERE YEAR(BIRTHDATE) = 1941;
```

Example 2: The following invocations of the YEAR function returns the same result:

```
SELECT YEAR('1993-08-10-20.00.00'),
       YEAR('1993-08-10-20.00.00-08:00'),
       YEAR('1993-08-10-20.00.00+09:00')
FROM SYSIBM.SYSDUMMY1;
```

For each invocation of the YEAR function in this SELECT statement, the result is 1993.

When the input argument contains a time zone, the result is determined from the UTC representation of the input value. The string representations of a timestamp with a time zone in the SELECT statement all have the same UTC representation: '1993-08-10-20.00.00'.

Table functions

A table function can be used only in the FROM clause of a statement. Table functions return columns of a table and resemble a table created using a CREATE TABLE statement. Table functions can be qualified with a schema name.

ADMIN_TASK_LIST table function

The ADMIN_TASK_LIST function returns a table with one row for each of the tasks that are defined in the administrative task scheduler task list.

Authorization

The user who calls this function must have MONITOR1 privilege.

```
►► ADMIN_TASK_LIST() ◄◄
```

The schema is DSNADM.

The result of the function is a table with the format shown in the following table. All the columns are nullable except TASK_NAME.

Table 102. Format of the resulting table for ADMIN_TASK_LIST

Column name	Data type	Contains
BEGIN_TIMESTAMP	TIMESTAMP	<p>Contains the timestamp of when the task can first run. When the task begins to run depends on what values this and other columns contain:</p> <ul style="list-style-type: none"> • If BEGIN_TIMESTAMP contains a non-null value: <ul style="list-style-type: none"> – If POINT_IN_TIME and TRIGGER_TASK_NAME contain null values, the task begins to run at the timestamp in BEGIN_TIMESTAMP – If POINT_IN_TIME contains a non-null value, the task begins to run at the next point in time that is defined at or after the timestamp in BEGIN_TIMESTAMP – If TRIGGER_TASK_NAME is a non-null value, the task begins to run at the next time that the task identified in TRIGGER_TASK_NAME completes or after the timestamp in BEGIN_TIMESTAMP • If BEGIN_TIMESTAMP contains a null value: <ul style="list-style-type: none"> – If POINT_IN_TIME and TRIGGER_TASK_NAME contain null values, the task begins to run immediately – If POINT_IN_TIME contains a non-null value, the task begins to run at the next point in time that is defined – If TRIGGER_TASK_NAME is a non-null value, the task begins to run at the next time that the task identified in TRIGGER_TASK_NAME completes
END_TIMESTAMP	TIMESTAMP	<p>Contains the timestamp of when the task is last able to run. If this column is NULL, there are no restrictions as to when the task must not run.</p>
MAX_INVOCATIONS	INTEGER	<p>Contains the maximum number of times the task can run. The maximum number applies to all types of schedules: triggered by events, scheduled by time interval, or by point in time. If this column is null, the task has no limit on the number of times it can be run.</p> <p>If both END_TIMESTAMP and MAX_INVOCATIONS contain values, the value in END_TIMESTAMP takes precedence over the value for MAX_INVOCATIONS. That is, if the value in END_TIMESTAMP is reached, even though the number of times the task has run has not reached the value for MAX_INVOCATIONS, the task will not run again</p>
INTERVAL	INTEGER	<p>Contains an integer that indicates the duration between the start of one instance of a task and the start of the next instance of the same task. If the value of this column is NULL, the task is not scheduled to run at a regular interval.</p>
POINT_IN_TIME	VARCHAR(400)	<p>Contains one or more points in time (in UNIX cron format) for which the task is scheduled to run. If the value of this column is NULL, the task is not scheduled to run at a specific point in time.</p> <p>The format contains the following pieces of information separated by blanks: given hour, given minute, given day of the week, given day of the month, given month of the year.</p>

Table 102. Format of the resulting table for ADMIN_TASK_LIST (continued)

Column name	Data type	Contains
TRIGGER_ TASK_NAME	VARCHAR(128)	<p>Contains the task name of the task that, when its execution is complete, will trigger the running of the task that is described in the row.</p> <p>Task name DB2STOP is reserved for Db2 stop events and task name DB2START is reserved for Db2 start events. Those events are handled by the administrative task scheduler that is associated with the Db2 subsystem that is starting or stopping.</p> <p>If the value of this column is NULL, the task that is described in this row will not be triggered to run by another task.</p>
TRIGGER_ TASK_COND	CHAR(2)	<p>Contains the type of comparison that is to be made to the return code after the running of task that is indicated in TRIGGER_TASK_NAME. The following values are possible:</p> <p>GT Greater than</p> <p>GE Greater than or equal to</p> <p>EQ Equal to</p> <p>LT Less than</p> <p>LE Less than or equal to</p> <p>NE Not equal to</p> <p>If this column contains NULL, the task is triggered to run without consideration of the return code of the task that is indicated in TRIGGER_TASK_NAME.</p>
TRIGGER_ TASK_CODE	INTEGER	<p>Contains the return code from running the task indicated in TRIGGER_TASK_NAME.</p> <p>If the running of this task is triggered by a stored procedure, TRIGGER_TASK_CODE contains the SQLCODE that must be returned by the stored procedure in order for this task to run.</p> <p>If the running of this task is triggered by a JCL job, TRIGGER_TASK_CODE contains the MAXRC that must be returned by the job in order for this task to run.</p> <p>“ADMIN_TASK_STATUS table function” on page 675 returns the SQLCODE or MAXRC value in the SQLCODE or MAXRC column.</p> <p>If TRIGGER_TASK_COND is NULL, this column will also be NULL.</p>

Table 102. Format of the resulting table for ADMIN_TASK_LIST (continued)

Column name	Data type	Contains
DB2_SSID	VARCHAR(4)	<p>Contains the Db2 subsystem ID of the Db2 subsystem that is associated with the administrative task scheduler that should run this task.</p> <p>The value in this column is used in a data sharing environment where, for example different Db2 members have different configurations and running the task relies on a certain environment. A value in DB2_SSID will prevent an administrative scheduler of other members to run this task, so that the task can only be run as long as the administrative task scheduler of the subsystem indicated in DB2_SSID is running.</p> <p>For a task that is being triggered by a Db2 start or Db2 stop event as indicated in the TRIGGER_TASK_NAME column, a value in DB2_SSID will allow the task to be run only when the indicated subsystem is starting or stopping. If no value is indicated in DB2_SSID, each subsystem that starts or stops will trigger a the task to be run locally, provided that the triggered task is run serially.</p> <p>If this column is NULL, any administrative scheduler can run this task.</p>
PROCEDURE_SCHEMA	VARCHAR(128)	Contains the schema of the Db2 stored procedure that this task will run. If the value of this column is null, Db2 uses a default schema.
PROCEDURE_NAME	VARCHAR(128)	Contains the name of the Db2 stored procedure that this task will run. If the value of this column is NULL, no stored procedure will be called when this task is run.
PROCEDURE_INPUT	VARCHAR(4096)	Contains a statement that returns one row of data. The returned value will be used as the input parameter of the stored procedure that this task will run. If this column contains the null value, no parameters are passed to the stored procedure when this task is run.
JCL_LIBRARY	VARCHAR(44)	Contains the name of the data set that contains the JCL job that is run when this task is run. If the value of this column is the null value, no JCL job will be run when this task is run.
JCL_MEMBER	VARCHAR(8)	Contains the name of the library member that contains the JCL job that is run when this task is run. If the value of this column is the null value, the data set that is specified in JCL_LIBRARY is sequential and contains the JCL job that is run when this task is run.

Table 102. Format of the resulting table for ADMIN_TASK_LIST (continued)

Column name	Data type	Contains
JOB_WAIT	VARCHAR(8)	Contains one of the following values, which indicates whether the JCL job can be run synchronously. If the value in the column is not null, this column contains one of the following values: NO Runs asynchronously YES Runs synchronously PURGE Runs synchronously and then the job status in z/OS is purged
TASK_NAME	VARCHAR(128)	Contains the unique name that is assigned to this task.
DESCRIPTION	VARCHAR(128)	Contains a description of the task if one exists.
USERID	VARCHAR(128)	Contains the authorization ID of the user under which the task will be invoked. If this column is NULL, the task is invoked by the default authorization ID that is associated with the administrative task scheduler.
CREATOR	VARCHAR(128)	Contains the authorization ID that added the task to the administrative task scheduler task list.
LAST_MODIFIED	TIMESTAMP	Timestamp of when the task was added or last modified.

Example 1: Retrieve information about all of the tasks that are defined in the administrative task scheduler task list:

```
SELECT *
FROM TABLE (DSNADM.ADMIN_TASK_LIST()) AS T;
```

ADMIN_TASK_OUTPUT table function

For an execution of a stored procedure, the ADMIN_TASK_OUTPUT function returns the output parameter values and result sets, if available. If the task that was executed is not a stored procedure or the requested execution status is not available, the function returns an empty table.

Authorization

The user who calls this function must have MONITOR1 privilege.

```
►► ADMIN_TASK_OUTPUT( task-name ,num-invocations ) ◄◄
```

The schema is DSNADM.

Important: The ADMIN_TASK_OUTPUT function returns as many output parameter values and result sets as possible. However, this information is not always available. The administrative task scheduler cannot store output that exceeds 32,180 bytes in length. Therefore, some output parameters and result set values might be null if the values are too long to be stored by the administrative task scheduler. Also, if the result sets are too large to be stored, only some of the most recent rows of each result set might be available (for example, the first rows missing).

task-name

Specifies the unique name of the task whose execution output you want returned. This is an input parameter of type VARCHAR(128).

num-invocations

Specifies the execution number of the task whose output you want returned. This value must be a valid value in the NUM_INVOCATIONS column of the returned table of DSNADM.ADMIN_TASK_STATUS(NULL) for the specified task. This is an input parameter of type INTEGER.

The result of the function is a table with the format shown in the following table. This function might return an empty table for the output of a stored procedure for the following reasons:

- The stored procedure does not have output parameters or result sets.
- The output of the stored procedure was not stored at execution time, because the SYSIBM.ADMIN_TASKS_HIST table was not available.
- The *num-invocations* parameter is not valid.
- The output for the task that is specified by the *num-invocations* parameter is no longer stored, because the task is older than the value that is specified for the MAXHIST parameter of the administrative task scheduler. (The MAXHIST parameter specifies the maximum number of execution statuses to keep for each task.)

Table 103. Format of the resulting table for ADMIN_TASK_OUTPUT

Column name	Data type	Contains
RESULT_SET	SMALLINT	Contains the stored procedure result set number with a value beginning at 1, or NULL if this value is for an output parameter of the stored procedure.
ROW	SMALLINT	Contains the result set row number with a value beginning at 1, or NULL if this value is for an output parameter of the stored procedure.
COLUMN	SMALLINT	Contains the result set column number, or the index of an output parameter of the stored procedure parameters, with a value beginning at 1. Only the values of output parameters are returned, and the results include the index in all parameters of the stored procedure.
TYPE	CHAR(8)	Contains the type of the returned string. Possible types are: <ul style="list-style-type: none"> • DATE • TIME • TIMESTMP • CHAR • VARCHAR • FLOAT • BIGINT • INTEGER • SMALLINT • OTHER The value OTHER includes all other data types that are not supported in this stored procedure.
VALUE	VARCHAR(32180)	Contains the string representation of the output parameter value or the result set column value. This column is null if the TYPE column contains OTHER.

Related tasks

[Displaying the results of a stored procedure task \(Db2 Administration Guide\)](#)

ADMIN_TASK_STATUS table function

The ADMIN_TASK_STATUS function returns a table with one row for each task that is defined in the administrative task scheduler task list. Each row indicates the status of the task for the last time it was run.

Optionally, if you specify the *max-history* parameter, the function returns a row of data for each execution of a task (up to the *max-history* value). For tasks that have not been executed, this function returns a row of data with a NULL status.

Authorization

The user who calls this function must have MONITOR1 privilege.

```
➤ ADMIN_TASK_STATUS( max-history ) ➤
```

The schema is DSNADM.

max-history

Specifies the maximum number of execution statuses per task to be returned. The most recent execution statuses are returned.

If the parameter is set to NULL, all available task execution statuses are returned. If the parameter is set to 1, only the status for the last time the task was run is returned, which is the same result as not specifying this option. This is an input parameter of type INTEGER.

The result of the function is a table with the format shown in the following table.

Table 104. Format of the resulting table for ADMIN_TASK_STATUS

Column name	Data type	Contains
TASK_NAME	VARCHAR(128)	Contains the name of the task that has run, is running, or has been bypassed.
STATUS	VARCHAR(10)	Contains one of the following values that indicates task status: RUNNING The task is currently running COMPLETED The task has finished running. For asynchronous tasks (JCL jobs), this column contains COMPLETED whenever the job is submitted to be run. Otherwise, this column contains COMPLETED only after the task has finished running. NOTRUN The task was not run at the scheduled invocation time. The MSG column contains the error or warning message that indicates why the task was not run. UNKNOWN The scheduler shut down while the task was running. The scheduler is started again but cannot know the execution status of this interrupted task.

Table 104. Format of the resulting table for ADMIN_TASK_STATUS (continued)

Column name	Data type	Contains
NUM_ INVOCATIONS	INTEGER	Contains the number of times the administrative task scheduler attempted to run the task, including the current time if the task is currently running. The values in this column does not indicate if the task was successfully run.
START_ TIMESTAMP	TIMESTAMP	Contains the time when the task started running if the STATUS column contains COMPLETED, RUNNING, or UNKNOWN. Otherwise, this column contains the time that the task should have started to run but could not.
END_ TIMESTAMP	TIMESTAMP	Contains the time when the task finished running.
JOB_ID	CHAR(8)	Contains the job ID that is assigned to the JCL job submitted by the administrative task scheduler. This column contains NULL if the task is a stored procedure or if the STATUS column does not contain COMPLETED.
MAXRC	INTEGER	Contains the highest return code from submitting a JCL job. If the task is synchronous, the value in this column is changed to the return code that is returned when the job finishes running. This column is set to NULL if the task is a stored procedure, if the STATUS column does not contain COMPLETED, or if a synchronous task is finished and has run with JES3 in a z/OS 1.7 or earlier system.

Table 104. Format of the resulting table for ADMIN_TASK_STATUS (continued)

Column name	Data type	Contains
COMPLETION_ TYPE	INTEGER	<p>Contains one of the following values that indicates the completion type of the JCL job submitted by the administrative task scheduler:</p> <p>0 No completion information</p> <p>1 Job ended normally</p> <p>2 Job ended by completion code</p> <p>3 Job had a JCL error</p> <p>4 Job was canceled</p> <p>5 Job abended</p> <p>6 Converter abended while processing the job</p> <p>7 Job failed security checks</p> <p>8 Job failed in end-of-memory</p> <p>This column contains NULL if the task is a stored procedure, if the STATUS column does not contain COMPLETED, or if the JCL job is run with JES3 in a z/OS 1.7 or earlier system.</p>
SYSTEM_ ABENDCD	INTEGER	<p>Contains the system abend code returned by a failed JCL job that was submitted by the administrative task scheduler.</p> <p>This column contains NULL if the task is a stored procedure, if the STATUS column does not contain COMPLETED, or if the JCL job is run with JES3 in a z/OS 1.7 or earlier system.</p>
USER_ABENDCD	INTEGER	<p>Contains the user abend code returned by a failed JCL job that was submitted by the administrative task scheduler.</p> <p>This column contains NULL if the task is a stored procedure, if the STATUS column does not contain COMPLETED, or if the JCL job is run with JES3 in a z/OS 1.7 or earlier system.</p>
MSG	VARCHAR(128)	Contains the error or warning message from the last time the task was run.
SQLCODE	INTEGER	Contains the SQLCODE set by Db2 when a stored procedure was called by the administrative task scheduler. This column contains NULL if the task is a JCL job or if the STATUS column does not contain COMPLETED.
SQLSTATE	CHAR(5)	Contains the SQLSTATE set by Db2 when a stored procedure was called by the administrative task scheduler. This column contains NULL if the task is a JCL job or if the STATUS column does not contain COMPLETED.

Table 104. Format of the resulting table for ADMIN_TASK_STATUS (continued)

Column name	Data type	Contains
SQLERRP	VARCHAR(8)	Contains the SQLERRP set by Db2 when a stored procedure was called by the administrative task scheduler. This column contains NULL if the task is a JCL job or if the STATUS column does not contain COMPLETED.
SQLERRMC	VARCHAR(70)	Contains the SQLERRMC set by Db2 when a stored procedure was called by the administrative task scheduler. This column contains NULL if the task is a JCL job or if the STATUS column does not contain COMPLETED.
DB2_SSID	VARCHAR(4)	Contains the Db2 subsystem ID that is associated with the administrative task scheduler that ran the task or should have run the task.
USERID	VARCHAR(128)	Contain the user ID that the task ran under.

Example 1: Retrieve status information about all of the tasks that have run in the administrative task scheduler task list:

```
SELECT *  
FROM TABLE (DSNADM.ADMIN_TASK_STATUS()) AS T;
```

Related tasks

[Listing the last execution status of scheduled tasks \(Db2 Administration Guide\)](#)

[Listing multiple execution statuses of scheduled tasks \(Db2 Administration Guide\)](#)

BLOCKING_THREADS table function

The BLOCKING_THREADS function returns a table that contains one row for each lock or claim that threads hold against the databases that are specified in the input parameter.

Authorization

The set of privileges for each specified database must include one of the following privileges or authorities:

- DISPLAYDB privilege
- DISPLAY privilege
- DBMAINT authority
- DBCTRL authority
- DBADM authority
- System DBADM authority
- SYSOPR authority
- SYSCTRL authority
- SYSADM authority

For implicitly created databases, the database privilege or authority can be held on the implicitly created database or on DSNDB04.

Syntax

```
►► BLOCKING_THREADS( dbname ) ◄◄
```

The schema is SYSIBMADM.

dbname

An expression that returns a value that is a built-in character string or graphic string data type that is not a LOB. The expression must have an actual length that is no greater than 128 bytes. The value of the expression must refer to a database for which information is to be displayed. Multiple databases can be specified in the following forms:

<i>Table 105. Forms of dbname and dbstring</i>	
Form	Displays the information of...
<i>dbname1:dbname2</i>	All databases with names, in UNICODE order, that are between <i>dbname1</i> and <i>dbname2</i> inclusive
<i>dbname*</i>	All databases with names that begin with the string <i>dbname</i>
<i>*dbname</i>	All databases with names that end with the string <i>dbname</i>
<i>*dbname*</i>	All databases with names that contain the string <i>dbname</i>
<i>*dbstring1*dbstring2*</i>	All databases with names that contain the strings <i>dbstring1</i> and <i>dbstring2</i>

The result of the function is a table with the format shown in the following table. All of the columns are nullable.

<i>Table 106. Format of the resulting table for BLOCKING_THREADS</i>		
Column name	Data type	Contains...
ACQUIRED_TS	TIMESTAMP (12)	The time when the lock or claim was acquired
AGE	VARCHAR (128)	The elapsed time between when the lock or claim was acquired and when the function was invoked, with the following abbreviated keywords: D Days H Hours M Minutes S Seconds. Microseconds are represented by up to six decimal digits.
CORRID	VARCHAR (255)	The correlation identifier of the thread. If the STATE value indicates a physical lock (P-lock), CORRID has a null value or empty string.

Table 106. Format of the resulting table for BLOCKING_THREADS (continued)

Column name	Data type	Contains...
CONNID	VARCHAR (255)	The connection identifier of the thread. If the STATE value indicates a P-lock, CONNID has a null value or empty string.
USERID	VARCHAR (255)	The user ID of the thread. If the STATE value indicates a P-lock, USERID has a null value or empty string.
LUWID	VARCHAR (255)	The logical-unit-of-work identifier of the thread. If the STATE value indicates a P-lock, LUWID has a null value or empty string.
SSID	CHAR (4)	In data sharing, the Db2 data sharing member where the thread is running. Otherwise, this column is unused.
TYPE	CHAR (1)	The type of blocker held by the thread. TYPE can have one of the following values: L Lock C Claim I Indicates that the row is for informational purposes. The INFO column contains the information. E Indicates that an error occurred. The INFO column explains the error. D Indicates that the row is for serviceability purposes. The INFO column contains the serviceability information.

Table 106. Format of the resulting table for BLOCKING_THREADS (continued)

Column name	Data type	Contains...
SUBTYPE	CHAR (2)	<p>The type of lock or claim that blocking threads hold. Locks for blocking threads can have one of the following values:</p> <p>00 Page lock</p> <p>01 Database lock</p> <p>02 Page set lock</p> <p>03 Data set lock (partition)</p> <p>05 Index compression lock</p> <p>06 Lock-specific partition</p> <p>07 Page set or data set open</p> <p>08 Utility I/O damage assessment</p> <p>09 Page set piece locks</p> <p>Continues in next row.</p>

Table 106. Format of the resulting table for BLOCKING_THREADS (continued)

Column name	Data type	Contains...
SUBTYPE (cont.)		<p>0A Database exception table (DBET) entry locks</p> <p>0D Buffer manager (BM) SYSLGRNG recording lock or group buffer pool (GBP) conversion dependent lock</p> <p>0E Utility serialization lock</p> <p>0F Mass delete lock for table</p> <p>10 Table lock for segmented table space</p> <p>12 Package lock</p> <p>18 Row lock</p> <p>1F Distributed data facility (DDF) communications database (CDB) P-lock</p> <p>22 Resource limit facility (RLF) P-lock</p> <p>27 DBET logical page list (LPL) or group buffer pool recovery pending (GRECP) locks</p> <p>30 LOB lock</p> <p>32 LPL recovery lock</p> <p>36 Serialization lock for adding partitions</p> <p>39 Load database definition (DBD) lock</p> <p>3A Compression dictionary build lock</p> <p>3B Compression dictionary load lock</p> <p>41 Utility catalog access lock</p>

Table 106. Format of the resulting table for BLOCKING_THREADS (continued)

Column name	Data type	Contains...
SUBTYPE (cont.)		<p>Claims for blocking threads can have one of the following values:</p> <p>20 WR claim</p> <p>40 RR claim</p> <p>60 RR, WR claim</p> <p>80 CS claim</p> <p>A0 CS, WR claim</p>
DURATION	CHAR (2)	<p>The duration of the lock or claim. Locks can have one of the following values:</p> <p>20 Manual</p> <p>21 Manual+1</p> <p>40 Commit</p> <p>41 Commit+1</p> <p>60 Allocation</p> <p>80 Plan</p> <p>81 Utility</p> <p>FE Interest</p> <p>Claims can have one of the following values:</p> <p>CM Commit</p> <p>CH Cursor hold</p> <p>AL Allocation</p>

Table 106. Format of the resulting table for BLOCKING_THREADS (continued)

Column name	Data type	Contains...
STATE	CHAR (2)	The state in which the lock is held. Locks can have one of the following values: 01 Unprotected share 02 Intent shared 03 Intent exclusive 04 Shared 05 Update 06 Shared intent exclusive 07 Non-shared update 08 Exclusive 09 Intent exclusive P-lock 0A Intent shared P-lock 0B Shared intent exclusive P-lock
DBID	SMALLINT	The database identifier
OBID	SMALLINT	The object identifier
DBNAME	VARCHAR (24)	The database name
OBJECT_QUALIFIER	VARCHAR (128)	The schema of a table or index
OBJECT NAME	VARCHAR (128)	The name of a table, index, or table space
PAGENUM_OR_RID	VARCHAR (10)	Indicates one of the following values in hexadecimal format: <ul style="list-style-type: none"> • The page number if the lock is a page lock • The record ID if the lock is a row lock • The dataset number if the lock is a dataset lock • The partition number if the lock is a partition lock

Table 106. Format of the resulting table for BLOCKING_THREADS (continued)

Column name	Data type	Contains...
PACKAGE	VARCHAR (512)	The qualified package name (COLLECTION_ID.NAME.CONTOKEN) if the lock is a package lock
CATALOG_LEVEL	VARCHAR (10)	The catalog level. This column is currently not used and reserved for future use.
INFO	VARCHAR (1024)	Informational text if TYPE is I, D, or E

The function returns an informational message (TYPE=I) for any specified databases that do not hold any locks or claims.

Examples

Retrieve information about the threads that hold locks and claims against the Db2 catalog and directory databases:

```
SELECT *
FROM TABLE (SYSIBMADM.BLOCKING_THREADS('DSNDB06,DSNDB01'));
```

Related tasks

Identify applications that are incompatible with online migration (Db2 Installation and Migration)

Related reference

-DISPLAY BLOCKERS command (Db2) (Db2 Commands)

MQREADALL table function

The MQREADALL function returns a table that contains the messages and message metadata from a specified IBM MQ location without removing the messages from the queue.

►► MQREADALL(*receive-service* , *service-policy* , *num-rows* ¹) ◄◄

Notes:

¹ The comma is required before *num-rows* when any of the preceding arguments to the function are specified.

The schema is DB2MQ.

The MQREADALL function returns a table containing the messages and message meta-data from the IBM MQ location that is specified by *receive-service*, using the quality-of-service policy that is defined in *service-policy*. Performing this operation does not remove the messages from the queue that is associated with *receive-service*.

receive-service

An expression that returns a value that is a built-in character string or graphic string data type that is not a LOB. The value of the expression must not be an empty string or a string with trailing blanks. The expression must have an actual length that is no greater than 48 bytes. The value of the expression must refer to a service point that is defined in the DB2MQ.MQSERVICE table. A service point is a logical end-point from which a message is sent or received. A service point definition includes the

name of the IBM MQ queue manager and the name of the queue. See *IBM MQ Application Messaging Interface* for more details.

If *receive-service* is not specified or is the null value, DB2 . DEFAULT . POLICY is used.

service-policy

An expression that returns a value that is a built-in character string or graphic string data type that is not a LOB. The value of the expression must not be an empty string or a string with trailing blanks. The expression must have an actual length that is no greater than 48 bytes. The value of the expression must refer to a service policy that is defined in the DB2MQ.MQPOLICY table. A service policy specifies a set of quality-of-service options that are to be applied to this messaging operation. These options include message priority and message persistence. See *IBM MQ Application Messaging Interface* for more details.

If *service-policy* is not specified or is the null value, DB2 . DEFAULT . POLICY is used.

num-rows

An expression that returns a value that is a SMALLINT or INTEGER data type whose value is a positive integer or zero. The value of the expression specifies the maximum number of messages to return.

If *num-rows* is not specified or if the value of the expression is zero, all available messages are returned.

The result of the function is a table with the format shown in the following table. All the columns are nullable.

Table 107. Format of the resulting table for MQREADALL

Column name	Data type	Contains
MSG	VARCHAR(4000)	The contents of the IBM MQ message
CORRELID	VARCHAR(24)	The correlation ID that is used to relate messages
TOPIC	VARCHAR(40)	The topic that the message was published with, if available
QNAME	VARCHAR(48)	The name of the queue from which the message was received
MSGID	CHAR(24)	The unique message identifier assigned by IBM MQ
MSGFORMAT	VARCHAR(8)	The format of the message, as defined by IBM MQ

Examples

Example 1

Read all the messages from the queue specified by the default service (Db2.DEFAULT.SERVICE), using the default policy (Db2.DEFAULT.POLICY).

```
SELECT * FROM TABLE (MQREADALL()) AS T;
```

The messages and all the metadata are returned as a table.

Example 2

Read all the messages from the beginning of the queue specified by the service MYSERVICE, using the default policy (Db2.DEFAULT.POLICY).

```
SELECT T.MSG, T.CORRELID  
FROM TABLE (MQREADALL ('MYSERVICE')) AS T;
```

Only the MSG and CORRELID columns are returned.

Example 3

Read all the messages from the queue specified by the default service (Db2.DEFAULT.SERVICE), using the default policy (Db2.DEFAULT.POLICY). Only messages with a CORRELID of '1234' are returned.

```
SELECT *
FROM TABLE (MQREADALL(10)) AS T
WHERE T.CORRELID = '1234';
```

All columns are returned.

Example 4

Retrieve the first 10 messages from the beginning of the queue specified by the default service (Db2.DEFAULT.SERVICE), using the default policy (Db2.DEFAULT.POLICY).

```
SELECT *
FROM TABLE (MQREADALL(10)) AS T;
```

The first 10 messages and all the columns are returned as a table.

MQREADALLCLOB table function

The MQREADALLCLOB function returns a table that contains the messages and message metadata from a specified IBM MQ location without removing the messages from the queue.

```
MQREADALLCLOB( receive-service , service-policy , num-rows 1 )
```

Notes:

¹ The comma is required before *num-rows* when any of the preceding arguments to the function are specified.

The schema is DB2MQ.

The MQREADALLCLOB function returns a table containing the messages and message meta-data from the IBM MQ location that is specified by *receive-service*, using the quality-of-service policy that is defined in *service-policy*. Performing this operation does not remove the messages from the queue that is associated with *receive-service*.

receive-service

An expression that returns a value that is a built-in character string or graphic string data type that is not a LOB. The value of the expression must not be an empty string or a string with trailing blanks. The expression must have an actual length that is no greater than 48 bytes. The value of the expression must refer to a service point that is defined in the DB2MQ.MQSERVICE table. A service point is a logical end-point from which a message is sent or received. A service point definition includes the name of the IBM MQ queue manager and the name of the queue. See *IBM MQ Application Messaging Interface* for more details.

If *receive-service* is not specified or is the null value, DB2.DEFAULT.POLICY is used.

service-policy

An expression that returns a value that is a built-in character string or graphic string data type that is not a LOB. The value of the expression must not be an empty string or a string with trailing blanks. The expression must have an actual length that is no greater than 48 bytes. The value of the expression must refer to a service policy that is defined in the DB2MQ.MQPOLICY table. A service policy specifies a set of quality-of-service options that are to be applied to this messaging operation. These options include message priority and message persistence. See *IBM MQ Application Messaging Interface* for more details.

If *service-policy* is not specified or is the null value, DB2.DEFAULT.POLICY is used.

num-rows

An expression that returns a value that is a SMALLINT or INTEGER data type whose value is a positive integer or zero. The value of the expression specifies the maximum number of messages to return.

If *num-rows* is not specified or if the value of the expression is zero, all available messages are returned.

The result of the function is a table with the format shown in the following table. All the columns in the table are nullable.

Table 108. Format of the resulting table for MQREADALLCLOB

Column name	Data type	Contains
MSG	CLOB(1M)	The contents of the IBM MQ message
CORRELID	VARCHAR(24)	The correlation ID that is used to relate messages
TOPIC	VARCHAR(40)	The topic that the message was published with, if available
QNAME	VARCHAR(48)	The name of the queue from which the message was received
MSGID	CHAR(24)	The unique message identifier assigned by IBM MQ
MSGFORMAT	VARCHAR(8)	The format of the message, as defined by IBM MQ

The CCSID of the result is the system CCSID that was in effect at the time that the IBM MQ function was installed into Db2.

Examples

Example 1

Read all the messages from the queue specified by the default service (Db2.DEFAULT.SERVICE), using the default policy (Db2.DEFAULT.POLICY).

```
SELECT * FROM TABLE (MQREADALLCLOB()) AS T;
```

The messages and all the metadata are returned as a table.

Example 2

Read all the messages from the queue specified by the service MYSERVICE, using the default policy (Db2.DEFAULT.POLICY).

```
SELECT T.MSG, T.CORRELID  
FROM TABLE (MQREADALLCLOB('MYSERVICE')) AS T;
```

Only the MSG and CORRELID columns are returned as a table.

Example 3

Read all the messages from the queue specified by the service MYSERVICE, using the default policy (Db2.DEFAULT.POLICY), with a correlation identifier of '1234'.

```
SELECT * FROM TABLE (MQREADALLCLOB('MYSERVICE')) AS T  
WHERE T.CORRELID = '1234';
```

All columns are returned.

Example 4

Read the first 10 messages from the queue specified by the default service (Db2.DEFAULT.SERVICE), using the default policy (Db2.DEFAULT.POLICY).

```
SELECT * FROM TABLE (MQREADALLCLOB('10')) AS T;
```

All columns are returned.

MQRECEIVEALL table function

The MQRECEIVEALL function returns a table that contains the messages and message metadata from a specified IBM MQ location and removes the messages from the queue.

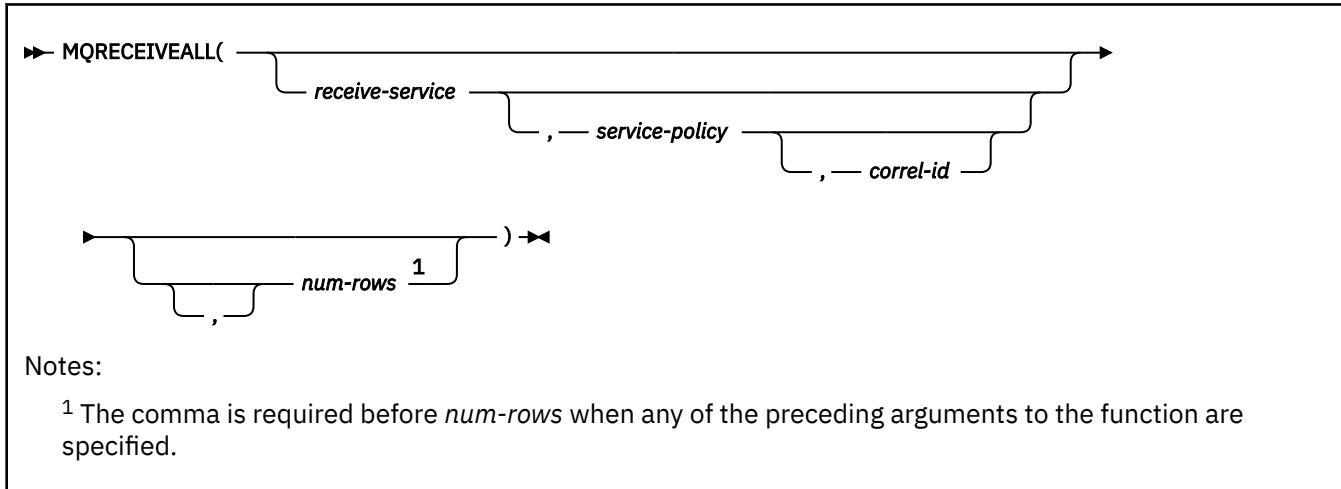

The schema is DB2MQ.

The MQRECEIVEALL function returns a table containing the messages and message meta-data from the IBM MQ location that is specified by *receive-service*, using the quality-of-service policy that is defined in *service-policy*. Performing this operation removes the messages from the queue that is associated with *receive-service*.

receive-service

An expression that returns a value that is a built-in character string or graphic string data type that is not a LOB. The value of the expression must not be an empty string or a string with trailing blanks. The expression must have an actual length that is no greater than 48 bytes. The value of the expression must refer to a service point that is defined in the DB2MQ.MQSERVICE table. A service point is a logical end-point from which a message is sent or received. A service point definition includes the name of the IBM MQ queue manager and the name of the queue. See *IBM MQ Application Messaging Interface* for more details.

If *receive-service* is not specified or is the null value, DB2 . DEFAULT . POLICY is used.

service-policy

An expression that returns a value that is a built-in character string or graphic string data type that is not a LOB. The value of the expression must not be an empty string or a string with trailing blanks. The expression must have an actual length that is no greater than 48 bytes. The value of the expression must refer to a service policy that is defined in the DB2MQ.MQPOLICY table. A service policy specifies a set of quality-of-service options that are to be applied to this messaging operation. These options include message priority and message persistence. See *IBM MQ Application Messaging Interface* for more details.

If *service-policy* is not specified or is the null value, DB2 . DEFAULT . POLICY is used.

correl-id

An expression that returns a value that is a built-in character string or graphic string data type that is not a LOB. The expression must have an actual length that is no greater than 24 bytes. The value of the expression specifies the correlation identifier that is associated with this message. A correlation identifier is often specified in request-and-reply scenarios to associate requests with replies. Only those messages with a matching correlation identifier are returned.

A fixed length string with trailing blanks is considered a valid value. However, when the *correl-id* is specified on another request such as MQSEND, the *correl-id* must be specified the same to be recognized as a match. For example, specifying a value of 'test' for *correl-id* for this function does not match a *correl-id* value of 'test ' (with trailing blanks) specified earlier on an MQSEND request.

If *correl-id* is not specified, is an empty string, or is the null value, a correlation identifier is not used, and the message at the beginning of the queue is returned.

num-rows

An expression that returns a value that is a SMALLINT or INTEGER data type whose value is a positive integer or zero. The value of the expression specifies the maximum number of messages to return.

If *num-rows* is not specified or if the value of the expression is zero, all available messages are returned.

The result of the function is a table with the format shown in the following table. All of the columns are nullable.

Table 109. Format of resulting table for MQRECEIVEALL

Column name	Data type	Contains
MSG	VARCHAR(4000)	The contents of the IBM MQ message
CORRELID	VARCHAR(24)	The correlation ID that is used to relate messages
TOPIC	VARCHAR(40)	The topic that the message was published with, if available
QNAME	VARCHAR(48)	The name of the queue from which the message was received
MSGID	CHAR(24)	The unique message identifier assigned by IBM MQ
MSGFORMAT	VARCHAR(8)	The format of the message, as defined by IBM MQ

The CCSID of the result is the system CCSID that was in effect at the time that the IBM MQ function was installed into Db2.

Examples

Example 1

Retrieve all the messages from the queue specified by the default service (Db2.DEFAULT.SERVICE), using the default policy (Db2.DEFAULT.POLICY).

```
SELECT * FROM TABLE (MQRECEIVEALL()) AS T;
```

The messages and all the metadata are returned as a table and the messages are removed from the queue.

Example 2

Retrieve all the messages from the queue specified by the service MYSERVICE, using the default policy (Db2.DEFAULT.POLICY).

```
SELECT T.MSG, T.CORRELID  
FROM TABLE (MQRECEIVEALL('MYSERVICE')) AS T;
```

Only the MSG and CORRELID columns are returned. The messages are removed from the queue.

Example 3

Retrieve all the messages from the beginning of the queue specified by the service MYSERVICE, using the policy MYPOLICY, with a correlation identifier of '1234'.

```
SELECT T.MSG, T.CORRELID  
FROM TABLE (MQRECEIVEALL('MYSERVICE', 'MYPOLICY', '1234')) AS T;
```

Only the MSG and CORRELID columns are returned. The messages are removed from the queue.

Example 4

Retrieve the first 10 messages from the beginning of the queue specified by the default service (Db2.DEFAULT.SERVICE), using the default policy (Db2.DEFAULT.POLICY).

```
SELECT * FROM TABLE (MQRECEIVEALL(10)) AS T;
```

All columns are returned. The messages are removed from the queue.

MQRECEIVEALLCLOB table function

The MQRECEIVEALLCLOB function returns a table that contains the messages and message metadata from a specified IBM MQ location and removes the messages from the queue.

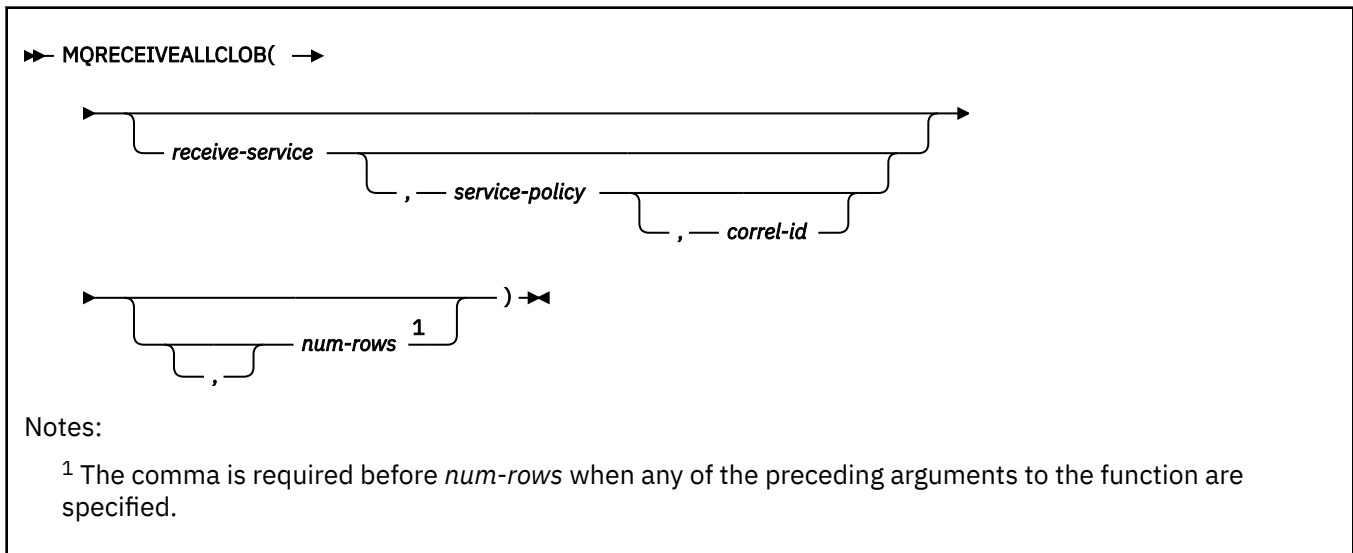

The schema is DB2MQ.

The MQRECEIVEALLCLOB function returns a table containing the messages and message metadata from the IBM MQ location that is specified by *receive-service*, using the quality-of-service policy that is defined in *service-policy*. Performing this operation removes the messages from the queue that is associated with *receive-service*.

receive-service

An expression that returns a value that is a built-in character string or graphic string data type that is not a LOB. The value of the expression must not be an empty string or a string with trailing blanks. The expression must have an actual length that is no greater than 48 bytes. The value of the expression must refer to a service point that is defined in the DB2MQ.MQSERVICE table. A service point is a logical end-point from which a message is sent or received. A service point definition includes the name of the IBM MQ queue manager and the name of the queue. See *IBM MQ Application Messaging Interface* for more details.

If *receive-service* is not specified or is the null value, DB2.DEFAULT.POLICY is used.

service-policy

An expression that returns a value that is a built-in character string or graphic string data type that is not a LOB. The value of the expression must not be an empty string or a string with trailing blanks. The expression must have an actual length that is no greater than 48 bytes. The value of the expression must refer to a service policy that is defined in the DB2MQ.MQPOLICY table. A service policy specifies a set of quality-of-service options that are to be applied to this messaging operation. These options include message priority and message persistence. See *IBM MQ Application Messaging Interface* for more details.

If *service-policy* is not specified or is the null value, DB2.DEFAULT.POLICY is used.

correl-id

An expression that returns a value that is a built-in character string or graphic string data type that is not a LOB. The expression must have an actual length that is no greater than 24 bytes. The value of the expression specifies the correlation identifier that is associated with this message. A correlation identifier is often specified in request-and-reply scenarios to associate requests with replies. Only those messages with a matching correlation identifier are returned.

A fixed length string with trailing blanks is considered a valid value. However, when the *correl-id* is specified on another request such as MQSEND, the *correl-id* must be specified the same to be recognized as a match. For example, specifying a value of 'test' for *correl-id* for this function does not match a *correl-id* value of 'test ' (with trailing blanks) specified earlier on an MQSEND request.

If *correl-id* is not specified, is an empty string, or is the null value, a correlation identifier is not used, and the message at the beginning of the queue is returned.

num-rows

An expression that returns a value that is a SMALLINT or INTEGER data type whose value is a positive integer or zero. The value of the expression specifies the maximum number of messages to return.

If *num-rows* is not specified or if the value of the expression is zero, all available messages are returned.

The result of the function is a table with the format shown in the following table. All of the columns are nullable.

Table 110. Format of resulting table for MQRECEIVEALLCLOB

Column name	Data type	Contains
MSG	CLOB(1M)	The contents of the IBM MQ message
CORRELID	VARCHAR(24)	The correlation ID that is used to relate messages
TOPIC	VARCHAR(40)	The topic that the message was published with, if available
QNAME	VARCHAR(48)	The name of the queue from which the message was received
MSGID	CHAR(24)	The unique message identifier assigned by IBM MQ
MSGFORMAT	VARCHAR(8)	The format of the message, as defined by IBM MQ

The CCSID of the result is the system CCSID that was in effect at the time that the IBM MQ function was installed into Db2.

Examples

Example 1

Retrieve all the messages from the queue specified by the default service (Db2.DEFAULT.SERVICE), using the default policy (Db2.DEFAULT.POLICY)

```
SELECT * FROM TABLE (MQRECEIVEALLCLOB()) AS T;
```

The messages and all the metadata are returned as a table, and the messages are removed.

Example 2

Retrieve all the messages from the beginning of the queue specified by the service MYSERVICE, using the policy (Db2.DEFAULT.POLICY)

```
SELECT T.MSG, T.CORRELID  
FROM TABLE (MQRECEIVEALLCLOB('MYSERVICE')) AS T;
```

Only the MSG and CORRELID columns are returned as a table, and the messages removed from the queue.

Example 3

Retrieve all the messages from the queue specified by the service MYSERVICE, using the policy "MYPOLICY", with a correlation identifier of '1234'

```
SELECT *
FROM TABLE (MQRECEIVEALLCLOB('MYSERVICE', 'MYPOLICY', '1234')) AS T;
```

All columns are returned, and the messages removed from the queue.

Example 4

Retrieve the first 10 messages from the beginning of the queue specified by the default service (Db2.DEFAULT.SERVICE), using the default policy (Db2.DEFAULT.POLICY)

```
SELECT *
FROM TABLE (MQRECEIVEALLCLOB(10)) AS T;
```

All columns are returned, and the messages removed from the queue.

XMLTABLE table function

The XMLTABLE function returns a result table from the evaluation of XQuery expressions, possibly by using specified input arguments as XQuery variables. Each item in the result sequence of the row XQuery expression represents one row of the result table.

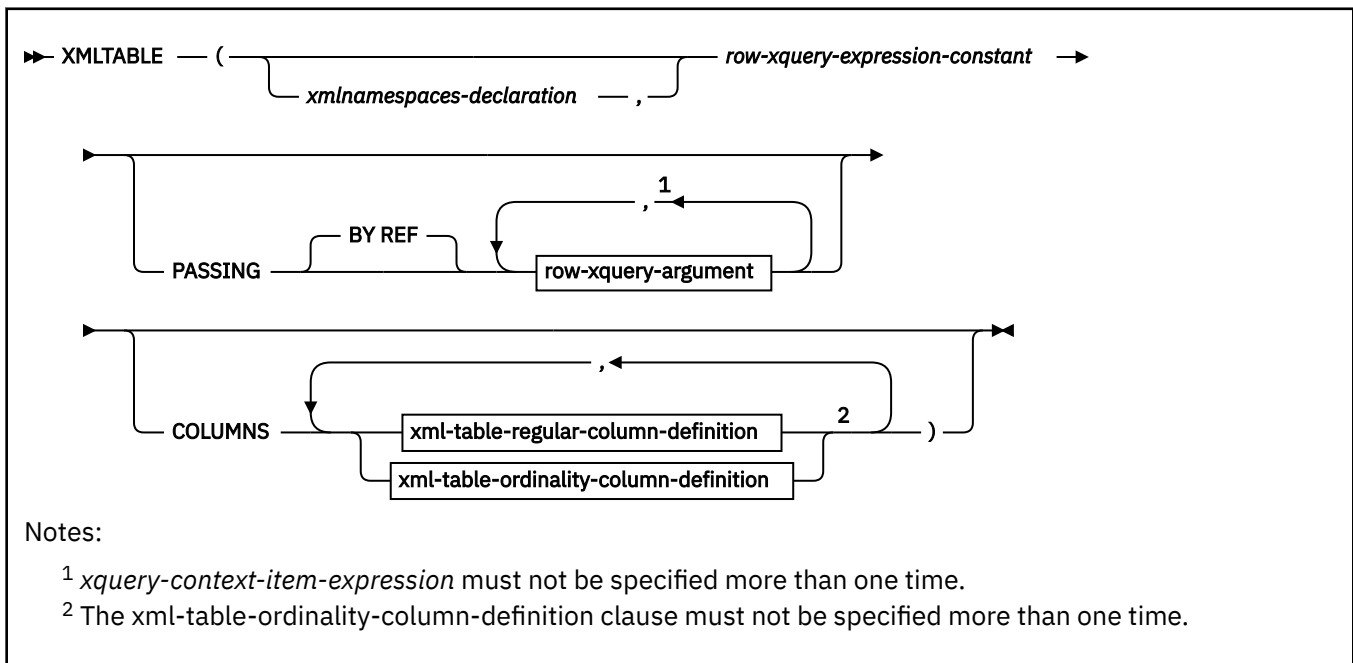

row-xquery-argument

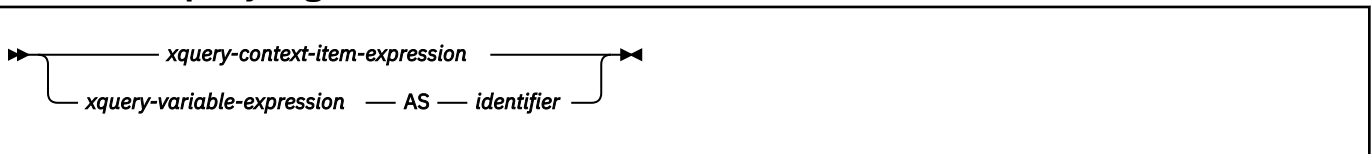

xml-table-regular-column-definition

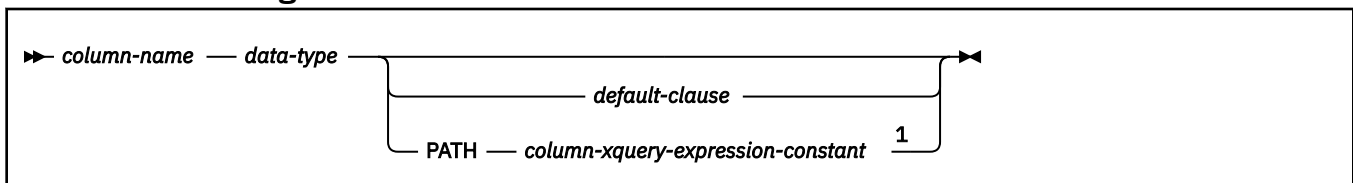

Notes:

¹ Neither the *default-clause* or the PATH clause can be specified more than one time.

xml-table-ordinality-column-definition

► *column-name* — FOR ORDINALITY ◄

The schema is SYSIBM.

The function name cannot be specified as a qualified name.

xmlnamespaces-declaration

Specifies one or more XML namespace declarations, using the XMLNAMESPACES function, that become part of the static context of the *row-xquery-expression-constant* and the *column-xquery-expression-constant*. The set of statically known namespaces for XQuery expressions which are arguments of XMLTABLE is the combination of the pre-established set of statically known namespaces and the namespace declarations specified in this clause. The XQuery prolog within an XQuery expression can override these namespaces.

If *xmlnamespaces-declaration* is not specified, only the pre-established set of statically known namespaces apply to the XQuery expressions.

row-xquery-expression-constant

Specifies an SQL character string constant that is interpreted as an XQuery expression using supported XQuery language syntax. *row-xquery-expression-constant* cannot be an XQuery updating expression. This expression determines the number of rows in the result table. The expression is evaluated using the optional set of input XML values that is specified in *row-xquery-argument*, and returns an output XQuery sequence where one row is generated for each item in the sequence. If the sequence is empty, the result of XMLTABLE is an empty table. *row-xquery-expression-constant* must not contain an empty string or a string of all blanks.

PASSING

Specifies input values and the manner in which these values are passed to *row-xquery-expression-constant*.

BY REF

Specifies that any XML input arguments are, by default, passed by reference. When XML values are passed by reference, the XQuery evaluation uses the input node trees, if any exist, directly from the specified input expressions and preserves all properties, including the original node identities and document order.

This clause has no impact on how non-XML values are passed. The non-XML values create a new copy of the value during the cast to XML.

row-xquery-argument

Specifies an argument that is to be passed to the XQuery expression specified by *row-xquery-expression-constant*. *row-xquery-argument* is an SQL expression that returns a value that is not a ROWID, LOB, DATE, TIME, TIMESTAMP, BINARY, VARBINARY, REAL, DECFLOAT, or character string with FOR BIT DATA attribute.

How *row-xquery-argument* is used in the XQuery expression depends on whether the argument is specified as an *xquery-context-item-expression* or an *xquery-variable-expression*.

If the data type of *row-xquery-argument* is not XML, the result of the expression for the argument is implicitly cast to XML. A null value is converted to an XML empty sequence if the argument is *xquery-variable-expression*.

row-xquery-argument must not contain NEXT VALUE or PREVIOUS VALUE expressions or OLAP specifications.

xquery-context-item-expression

An expression that returns a value that is XML, integer, decimal, or a character or graphic string that is not a LOB. *xquery-context-item-expression* must not be a character string that is bit data.

xquery-context-item-expression specifies the initial context item for the *row-xquery-expression*. The value of the initial context item is the result of *xquery-context-item-expression* cast to XML. *xquery-context-item-expression* must not be specified more than one time.

xquery-variable-expression

Specifies an SQL expression whose value is available to the XQuery expression specified by *row-xquery-expression-constant* during execution. The expression must return a value that is XML, integer, decimal, or a character or graphic string that is not a LOB.

xquery-variable-expression specifies an argument that will be passed to *row-xquery-expression-constant* as an XQuery variable. If *xquery-variable-expression* is a null value, the XQuery variable is set to an XML empty sequence. The scope of the XQuery variables that are created from the PASSING clause is the XQuery expression specified by *row-xquery-expression-constant*.

AS identifier

Specifies that the value generated by *xquery-variable-expression* will be passed to *row-xquery-expression-constant* as an XQuery variable. The variable name will be *identifier*. The leading dollar sign (\$) that precedes variable names in the XQuery language is not included in *identifier*. The identifier must not be greater than 128 bytes in length. Two arguments within the same PASSING clause cannot use the same identifier.

COLUMNS

Specifies the output columns of the result table including the column name, data type, and how the column value is computed for each row. If this clause is not specified, a single unnamed column of data type XML is returned, with the value based on the sequence item from evaluating the XQuery expression in the *row-xquery-expression-constant* (equivalent to specifying PATH '!'). To reference the result column, a *column-name* must be specified in the *correlation-clause* following the function.

xml-table-regular-column-definition

Specifies one output column of the result table including the column name, data type, and an XQuery expression to extract the value from the sequence item for the row.

column-name

Specifies the name of the column in the result table. The name cannot be qualified and the same name cannot be used for more than one column of the table.

data-type

Specifies the data type of the column. See CREATE TABLE for the syntax and a description of types available. A *data-type* can be used in XMLTABLE if there is a supported XMLCAST from the XML data type to the specified *data-type*.

default-clause

Specifies a default value for the column. See CREATE TABLE for the syntax and a description of the *default-clause*. For XMLTABLE result columns, the default is applied when the processing of the XQuery expression contained in *column-xquery-expression-constant* returns an empty sequence. This default value will not be inherited by declared global temporary tables even when the INCLUDING COLUMN DEFAULTS clause is specified in the definition of the declared global temporary table.

PATH column-xquery-expression-constant

Specifies an SQL character string constant that is interpreted as an XQuery expression using supported XQuery language syntax. The *column-xquery-expression-constant* specifies an XQuery expression that determines the column value with respect to an item that is the result of evaluating the XQuery expression in *row-xquery-expression-constant*. Given an item from the result of processing the *row-xquery-expression-constant* as the externally provided context item, the *column-xquery-expression-constant* is evaluated and returns an output sequence. The column value is determined based on this output sequence as follows.

- If the output sequence contains zero items, the *default-clause* provides the value of the column.
- If an empty sequence is returned and no *default-clause* was specified, a null value is assigned to the column.
- If a non-empty sequence is returned, the value is cast to the *data-type* specified for the column using the XMLCAST expression. An error could be returned from processing this XMLCAST.

The value for *column-xquery-expression-constant* must not be an empty string or a string of all blanks. If this clause is not specified, the default XQuery expression is simply the *column-name*.

xml-table-ordinality-column-definition

Specifies the ordinality column of the result table.

column-name

Specifies the name of the column in the result table. The name cannot be qualified and the same name cannot be used for more than one column of the table.

FOR ORDINALITY

Specifies that *column-name* is the ordinality column of the result table. The data type of this column is BIGINT. The value of this column in the result table is the sequential number of the item for the row in the resulting sequence from evaluating the XQuery expression in *row-xquery-expression-constant*.

The result of the function is a table. The encoding scheme of the table is Unicode. If the evaluation of any of the XQuery expressions results in an error, the XMLTABLE function returns the XQuery error.

Example: List as a table result the purchase order items for orders with a status of 'NEW':

```
SELECT U."PO ID", U."Part #", U."Product Name",
       U."Quantity", U."Price", U."Order Date"
FROM PURCHASEORDER P,
     XMLTABLE(XMLNAMESPACES('http://podemo.org' AS "pod"),
              '$po/PurchaseOrder/itemlist/item' PASSING P.PORDER as "po"
              COLUMNS "PO ID"          INTEGER          PATH '../@POid',
                     "Part #"         CHAR(6)          PATH 'product/@pid',
                     "Product Name"   CHAR(50)         PATH 'product/pod:name',
                     "Quantity"       INTEGER          PATH 'quantity',
                     "Price"          DECIMAL(9,2)       PATH 'product/pod:price',
                     "Order Date"     TIMESTAMP        PATH '../dateTime'
              ) AS U
WHERE P.STATUS = 'NEW'
```

Row functions

A row function can be used only in contexts that are specifically described for the function.

UNPACK row function

The UNPACK function returns a row of values that are derived from unpacking the input binary string. It is used to unpack a string that was encoded according to the PACK function.

►► UNPACK — (— *expression* —) ►►

The schema is SYSIBM.

expression

An expression that returns the string value to be unpacked. The *expression* must be a binary string that is not a BLOB and that is not null. The format of the binary string must match the one that is produced by the PACK function.

The UNPACK function can only be specified in the SELECT list and the SET clause of the UPDATE statement.

The result of the function is a row of fields corresponding to the data elements that were encoded in the input packed string. The result is not null.

Example 1: Assume that a user-defined function named myUDF returns a VARBINARY result. The body of the function includes the following invocation of the PACK function to pack some data into a binary string:

```
SET :udf_result = PACK(CCSID 1208, 'Alina', DATE('1977-08-01'),
                      DOUBLE(0.5));
```

The following SELECT statement unpacks the result of the myUDF function and returns a row of individual column values:

```
SELECT UNPACK(myUDF(C1)).* AS(Name VARCHAR(40) CCSID UNICODE,
                             DOB DATE,
                             Score DOUBLE)
FROM T1;
```

The use of "."* indicates that the result of the UNPACK function should be flattened into a list of result column values. When the UNPACK function is used in a select clause, an AS clause is specified to provide the names and data types for the resulting values.

Example 2: Assume that a user-defined function UDF_SCORE returns a VARBINARY result. The PACK function is invoked to return a binary string in which the column values of table T1 are encoded and packed. The UNPACK function returns the individual data values for a row with column names ID, SCORE, and CONF:

```
SELECT T1.C1, T1.C2, T1.C3, T1.C4,
       UNPACK( UDF_SCORE( PACK(CCSID 1208, T1.C1, T1.C2, T1.C3)) ).*
       AS (ID INT, SCORE DOUBLE, CONF DOUBLE)
FROM T1;
```

Example 3: Assume that a user-defined function named myUDF returns a VARBINARY result. The body of the function includes the following invocation of the PACK function to pack some data into a binary string. The character data that is packed includes EBCDIC and Unicode data. The CCSID DEFAULT clause causes the data to be packed with its original encoding.

```
SET :udf_result = PACK(CCSID DEFAULT,
                      CAST('Privet' AS VARCHAR(10) CCSID UNICODE),
                      CAST(NULL AS TIME), CAST('Bridget' AS VARCHAR(20) CCSID EBCDIC));
```

The following SELECT statement unpacks the result of the myUDF function and returns a row of individual column values. The CCSID clauses ensure that the data is unpacked in the same encoding scheme as it was before it was packed.

```
SELECT UNPACK(myUDF(C1)).* AS(MSG VARCHAR(10) CCSID UNICODE,
                             DOB DATE,
                             NAME VARCHAR(20) CCSID EBCDIC)
FROM T1;
```

Related reference

[PACK scalar function](#)

The PACK function returns a binary string value that contains a data type array and a packed representation of each non-null *expression* argument.

[select-clause](#)

The SELECT clause specifies the columns of the final result table. The column values are produced by the application of the *select list* to R. The select list is a list of names and expressions specified in the SELECT clause, and R is the result of the previous operation of the subselect. For example, if SELECT, FROM, and WHERE are the only clauses specified, then R is the result of that WHERE clause.

[unpacked-row](#)

An *unpacked-row* specifies a row that is the result of an invocation of the UNPACK built-in function.

Chapter 5. Procedures that are supplied with Db2

A *procedure* is an application program that can be started through the SQL CALL statement. The procedure is specified by a procedure name, which may be followed by arguments that are enclosed within parentheses. This information contains syntax diagrams, semantic descriptions, rules, and examples of the use of the system supplied procedures.

Important: Do not create additional versions of Db2-supplied procedures by specifying the VERSION keyword. Only versions that are supplied with Db2 are supported. Additional versions of such routines cause the installation and configuration of Db2-supplied routines to fail.

Related concepts

[Routines in Db2 for z/OS: functions and procedures \(Introduction to Db2 for z/OS\)](#)

[Migration step 23: Configure Db2 for running stored procedures and user-defined functions \(optional\) \(Db2 Installation and Migration\)](#)

[Common SQL API stored procedures \(Db2 Administration Guide\)](#)

Related tasks

[Migration step 24: Set up Db2-supplied routines \(Db2 Installation and Migration\)](#)

[Installing Db2-supplied routines during installation \(Db2 Installation and Migration\)](#)

[Implementing Db2 stored procedures \(Db2 Administration Guide\)](#)

Related reference

[CALL statement](#)

The CALL statement invokes a stored procedure.

[Installation information for procedures and functions that are supplied with Db2 \(Db2 Installation and Migration\)](#)

ADMIN_COMMAND_DB2 stored procedure

The SYSPROC.ADMIN_COMMAND_DB2 stored procedure executes one or more Db2 commands on a connected Db2 subsystem, or on a Db2 data sharing group member. This stored procedure also returns the command output messages.



Environment

ADMIN_COMMAND_DB2 must run in a WLM-established stored procedure address space.

Authorization

To execute the CALL statement, the owner of the package or plan that contains the CALL statement must have one or more of the following privileges on each package that the stored procedure uses:

- The EXECUTE privilege on the package for DSNADMCD
- Ownership of the package
- PACKADM authority for the package collection
- SYSADM authority

To execute the Db2 command, you must use a privilege set that includes the authorization to execute the Db2 command. For more information, see "Privileges and authorization IDs for commands" in [Commands in Db2 \(Db2 Commands\)](#).

Syntax

The following syntax diagram shows the SQL CALL statement for invoking this stored procedure:

```

▶▶ CALL — SYSPROC.ADMIN_COMMAND_DB2 — ( — db2-command , — command-length , →
    ▶ — processing-type , — db2-member — , — commands-executed , — IFI-return-code , →
        └─── NULL ───┘
    ▶ — IFI-reason-code , — excess-bytes , — group-IFI-reason-code , — group-excess-bytes , →
    ▶ — return-code , — message — ) →▶

```

Option descriptions

db2-command

Specifies any Db2 command, such as -DISPLAY THREAD(*), or multiple Db2 commands. With multiple Db2 commands, use a null value (CHAR string of '\0') to delimit the commands. The Db2 command is executed using the authorization ID of the user who invoked the stored procedure.

If you specify *processing-type*, you must specify the command name in full, such as "-DISPLAY THREAD". You cannot abbreviate Db2 commands, such as "-DIS THD".

This is an input parameter of type VARCHAR(32704) and cannot be null.

command-length

Specifies the length of the Db2 command or commands. When multiple Db2 commands are specified in *db2-command*, *command-length* is the sum of all of those commands, including the '\0' command delimiters.

This is an input parameter of type INTEGER and cannot be null.

processing-type

Identifies the action that you want ADMIN_COMMAND_DB2 to complete. You can request ADMIN_COMMAND_DB2 to parse the output messages of a command and provide the formatted result in a global temporary table, or you can request for a command to run synchronously.

If you specify *processing-type*, you must specify *db2-command* as a full command name, such as "-DISPLAY THREAD". You cannot abbreviate Db2 commands, such as "-DIS THD".

To request output message parsing, specify one of the following values:

Note: If you specify any of the following values, ADMIN_COMMAND_DB2 returns the parsed output message in a second result, as described in the Output section. Otherwise, if you specify any value that does not appear in the list below, ADMIN_COMMAND_DB2 returns the complete unparsed command output message, and only one result set is returned.

BP

Parse "-DISPLAY BUFFERPOOL" command output messages.

DB

Parse "-DISPLAY DATABASE" command output messages and return database information.

TS

Parse "-DISPLAY DATABASE(...) SPACENAM(...)" command output messages and return table spaces information.

IX

Parse "-DISPLAY DATABASE(...) SPACENAM(...)" command output messages and return index spaces information.

THD

Parse "-DISPLAY THREAD" command output messages.

If the -DISPLAY THREAD command includes the SCOPE(GROUP) option, ADMIN_COMMAND_DB2 returns parsed output in the second result set (in created temporary table SYSIBM.DB2_THREAD_STATUS) only for the data sharing member that appears first in the output.

ADMIN_COMMAND_DB2 returns unparsed output in the first result set (in created temporary table SYSIBM.DB2_CMD_OUTPUT) for the other data sharing members.

UT

Parse "-DISPLAY UTILITY" command output messages.

GRP

Parse "-DISPLAY GROUP" command output messages.

DDF

Parse "-DISPLAY DDF" command output messages.

LS

Parse "-DISPLAY DATABASE(...) SPACENAM(...)" command output messages and return information for LOB table spaces.

XS

Parse "-DISPLAY DATABASE(...) SPACENAM(...)" command output messages and return information for XML table spaces.

UN

Parse "-DISPLAY DATABASE(...) SPACENAM(...)" command output messages and return information for table spaces when the type is unknown.

To request for a command to run synchronously, specify:

SYC

Issue the command synchronously.

Only the following commands can be processed synchronously. For all other commands, SYC is ignored.

- -ALTER BUFFERPOOL
- -SET LOG
- -SET SYSPARM
- -STOP DATABASE

This is an input parameter of type VARCHAR(3).

db2-member

Specifies the name of a single data sharing group member on which an IFI request is to be executed

This is an input parameter of type VARCHAR(8).

commands-executed

Provides the number of commands that were executed

This is an output parameter of type INTEGER.

IFI-return-code

Provides the IFI return code

This is an output parameter of type INTEGER.

IFI-reason-code

Provides the IFI reason code

This is an output parameter of type INTEGER.

excess-bytes

Indicates the number of bytes that did not fit in the return area

This is an output parameter of type INTEGER.

group-IFI-reason-code

Provides the reason code for the situation in which an IFI call requests data from members of a data sharing group, and not all the data is returned from group members.

This is an output parameter of type INTEGER.

group-excess-bytes

Indicates the total length of data that was returned from other data sharing group members and did not fit in the return area

This is an output parameter of type INTEGER.

return-code

Provides the return code from the stored procedure. Possible values are:

0

The stored procedure did not encounter an SQL error during processing. Check the *IFI-return-code* value to determine whether the Db2 command issued using the instrumentation facility interface (IFI) was successful or not.

12

The stored procedure encountered an SQL error during processing. The *message* output parameter contains messages describing the SQL error.

This is an output parameter of type INTEGER.

message

Contains messages describing the SQL error encountered by the stored procedure. If no SQL error occurred, then no message is returned.

The first messages in this area are generated by the stored procedure. Messages that are generated by Db2 might follow the first messages.

This is an output parameter of type VARCHAR(1331).

Example

The following C language sample shows how to invoke ADMIN_COMMAND_DB2:

```
#include <stdio.h>
#include <stdlib.h>
#include <string.h>

/***** DB2 SQL Communication Area *****/
EXEC SQL INCLUDE SQLCA;

int main( int argc, char *argv[] ) /* Argument count and list */
{
    /***** DB2 Host Variables *****/
    EXEC SQL BEGIN DECLARE SECTION;

    /* SYSPROC.ADMIN_COMMAND_DB2 parameters */
    char      command[32705]; /* DB2 command */
    short int ind_command; /* Indicator variable */
    long int  lencommand; /* DB2 command length */
    short int ind_lencommand; /* Indicator variable */
    char      parsetype[4]; /* Parse type required */
    short int ind_parsetype; /* Indicator variable */
    char      mbrname[9]; /* DB2 data sharing group */
    /* member name */
    short int ind_mbrname; /* Indicator variable */
    long int  excommands; /* Number of commands exec. */
    short int ind_excommands; /* Indicator variable */
    long int  retifca; /* IFI return code */
    short int ind_retifca; /* Indicator variable */
    long int  resifca; /* IFI reason code */
    short int ind_resifca; /* Indicator variable */
    long int  xsbytes; /* Excessive bytes */
    short int ind_xsbytes; /* Indicator variable */
    long int  gresifca; /* IFI group reason code */
    short int ind_gresifca; /* Indicator variable */
    long int  gxsbytes; /* Group excessive bytes */
    short int ind_gxsbytes; /* Indicator variable */
    long int  retcd; /* Return code */
    short int ind_retcd; /* Indicator variable */
    char      errmsg[1332]; /* Error message */
    short int ind_errmsg; /* Indicator variable */

    /* Result Set Locators */
    volatile SQL TYPE IS RESULT_SET_LOCATOR * rs_loc1,
```

```

                                rs_loc2;

/* First result set row
long int    rownum;                /* Sequence number of the
char        text[81];              /* table row
                                           /* Command output

/* Second result set row
long int    ddfrownum;              /* DDF table sequence
char        ddfstat[7];            /* DDF status
char        ddfloc[19];            /* DDF location
char        ddf lunm[18];          /* DDF luname
char        ddfgenlu[18];          /* DDF generic lu
char        ddfv4ipaddr[18];       /* DDF IPv4 address
char        ddfv6ipaddr[40];       /* DDF IPv6 address
short int   ind_ddfv6ipaddr;        /* Indicator variable
long int    ddftcpport;            /* DDF tcpport
long int    ddfresport;            /* DDF resport
char        ddfsqldom[46];         /* DDF sql domain
char        ddfrsyncdom[46];       /* DDF resync domain
short int   ind_ddfrsyncdom;        /* Indicator variable
long int    ddfsecport;            /* DDF secure port
short int   ind_ddfsecport;         /* Indicator variable
char        ddfipname[9];          /* DDF IPNAME
short int   ind_ddfipname;          /* Indicator variable
char        ddfaliasname1[19];     /* DDF alias 1 name
short int   ind_ddfaliasname1;     /* Indicator variable
long int    ddfaliasport1;         /* DDF alias 1 TCP/IP port
short int   ind_ddfaliasport1;     /* Indicator variable
long int    ddfaliassecport1;      /* DDF alias 1 secure port
short int   ind_ddfaliassecport1;  /* Indicator variable
char        ddfaliasname2[19];     /* DDF alias 2 name
short int   ind_ddfaliasname2;     /* Indicator variable
long int    ddfaliasport2;         /* DDF alias 2 TCP/IP port
short int   ind_ddfaliasport2;     /* Indicator variable
long int    ddfaliassecport2;      /* DDF alias 2 secure port
short int   ind_ddfaliassecport2;  /* Indicator variable
char        ddfaliasname3[19];     /* DDF alias 3 name
short int   ind_ddfaliasname3;     /* Indicator variable
long int    ddfaliasport3;         /* DDF alias 3 TCP/IP port
short int   ind_ddfaliasport3;     /* Indicator variable
long int    ddfaliassecport3;      /* DDF alias 3 secure port
short int   ind_ddfaliassecport3;  /* Indicator variable
char        ddfaliasname4[19];     /* DDF alias 4 name
short int   ind_ddfaliasname4;     /* Indicator variable
long int    ddfaliasport4;         /* DDF alias 4 TCP/IP port
short int   ind_ddfaliasport4;     /* Indicator variable
long int    ddfaliassecport4;      /* DDF alias 4 secure port
short int   ind_ddfaliassecport4;  /* Indicator variable
char        ddfaliasname5[19];     /* DDF alias 5 name
short int   ind_ddfaliasname5;     /* Indicator variable
long int    ddfaliasport5;         /* DDF alias 5 TCP/IP port
short int   ind_ddfaliasport5;     /* Indicator variable
long int    ddfaliassecport5;      /* DDF alias 5 secure port
short int   ind_ddfaliassecport5;  /* Indicator variable
char        ddfaliasname6[19];     /* DDF alias 6 name
short int   ind_ddfaliasname6;     /* Indicator variable
long int    ddfaliasport6;         /* DDF alias 6 TCP/IP port
short int   ind_ddfaliasport6;     /* Indicator variable
long int    ddfaliassecport6;      /* DDF alias 6 secure port
short int   ind_ddfaliassecport6;  /* Indicator variable
char        ddfaliasname7[19];     /* DDF alias 7 name
short int   ind_ddfaliasname7;     /* Indicator variable
long int    ddfaliasport7;         /* DDF alias 7 TCP/IP port
short int   ind_ddfaliasport7;     /* Indicator variable
long int    ddfaliassecport7;      /* DDF alias 7 secure port
short int   ind_ddfaliassecport7;  /* Indicator variable
char        ddfaliasname8[19];     /* DDF alias 8 name
short int   ind_ddfaliasname8;     /* Indicator variable
long int    ddfaliasport8;         /* DDF alias 8 TCP/IP port
short int   ind_ddfaliasport8;     /* Indicator variable
long int    ddfaliassecport8;      /* DDF alias 8 secure port
short int   ind_ddfaliassecport8;  /* Indicator variable
char        ddfmbripv4addr[18];     /* DDF DSG member IPv4 addr
short int   ind_ddfmbripv4addr;     /* Indicator variable
char        ddfmbripv6addr[40];     /* DDF DSG member IPv6 addr
short int   ind_ddfmbripv6addr;     /* Indicator variable
EXEC SQL END DECLARE SECTION;

/*****
/* Assign values to input parameters to execute the DB2
/* command "-DISPLAY DDF"
*****/

```

```

/* Set the indicator variables to 0 for non-null input parameters */
/* Set the indicator variables to -1 for null input parameters */
/*****
strcpy(command, "-DISPLAY DDF");
ind_command = 0;
lencommand = strlen(command);
ind_lencommand = 0;
strcpy(parsetype, "DDF");
ind_parsetype = 0;
ind_mbrname = -1;

/*****
/* Call stored procedure SYSPROC.ADMIN_COMMAND_DB2 */
/*****
EXEC SQL CALL SYSPROC.ADMIN_COMMAND_DB2
      (:command      :ind_command,
       :lencommand   :ind_lencommand,
       :parsetype    :ind_parsetype,
       :mbrname      :ind_mbrname,
       :excommands  :ind_excommands,
       :retifca      :ind_retifca,
       :resifca      :ind_resifca,
       :xsbytes      :ind_xsbytes,
       :gresifca     :ind_gresifca,
       :gxsbytes     :ind_gxsbytes,
       :retcd        :ind_retcd,
       :errmsg       :ind_errmsg);

/*****
/* Retrieve result set(s) when the SQLCODE from the call is +466, */
/* which indicates that result sets were returned */
/*****
if (SQLCODE == +466) /* Result sets were returned */
{
  /* ESTABLISH A LINK BETWEEN EACH RESULT SET AND ITS LOCATOR */
  EXEC SQL ASSOCIATE LOCATORS (:rs_loc1, :rs_loc2)
        WITH PROCEDURE SYSPROC.ADMIN_COMMAND_DB2;

  /* ASSOCIATE A CURSOR WITH EACH RESULT SET */
  EXEC SQL ALLOCATE C1 CURSOR FOR RESULT SET :rs_loc1;
  EXEC SQL ALLOCATE C2 CURSOR FOR RESULT SET :rs_loc2;

  /* PERFORM FETCHES USING C1 TO RETRIEVE ALL ROWS FROM THE */
  /* FIRST RESULT SET */
  EXEC SQL FETCH C1 INTO :rownum, :text;

  while(SQLCODE == 0)
  {
    EXEC SQL FETCH C1 INTO :rownum, :text;
  }

  EXEC SQL CLOSE C1;

  /* PERFORM FETCHES USING C2 TO RETRIEVE THE -DISPLAY DDF */
  /* PARSED OUTPUT FROM THE SECOND RESULT SET */
  EXEC SQL FETCH C2 INTO :ddfrownum, :ddfstat, :ddfloc,
        :ddfnum, :ddfgenlu,
        :ddf4ipaddr,
        :ddf6ipaddr:ind_ddfv6ipaddr,
        :ddfcpport, :ddfresport,
        :ddfsqldom,
        :ddfrsyncdom:ind_ddfrsyncdom,
        :ddfsecpport:ind_ddfsecpport,
        :ddfipname:ind_ddfipname,
        :ddfaliasname1:ind_ddfaliasname1,
        :ddfaliasport1:ind_ddfaliasport1,
        :ddfaliassecport1:ind_ddfaliassecport1,
        :ddfaliasname2:ind_ddfaliasname2,
        :ddfaliasport2:ind_ddfaliasport2,
        :ddfaliassecport2:ind_ddfaliassecport2,
        :ddfaliasname3:ind_ddfaliasname3,
        :ddfaliasport3:ind_ddfaliasport3,
        :ddfaliassecport3:ind_ddfaliassecport3,
        :ddfaliasname4:ind_ddfaliasname4,
        :ddfaliasport4:ind_ddfaliasport4,
        :ddfaliassecport4:ind_ddfaliassecport4,
        :ddfaliasname5:ind_ddfaliasname5,
        :ddfaliasport5:ind_ddfaliasport5,
        :ddfaliassecport5:ind_ddfaliassecport5,
        :ddfaliasname6:ind_ddfaliasname6,
        :ddfaliasport6:ind_ddfaliasport6,
        :ddfaliassecport6:ind_ddfaliassecport6,

```

```

:ddfaliasname7:ind_ddfaliasname7,
:ddfaliasport7:ind_ddfaliasport7,
:ddfaliassecport7:ind_ddfaliassecport7,
:ddfaliasname8:ind_ddfaliasname8,
:ddfaliasport8:ind_ddfaliasport8,
:ddfaliassecport8:ind_ddfaliassecport8,
:ddfmbripv4addr:ind_ddfmbripv4addr,
:ddfmbripv6addr:ind_ddfmbripv6addr;

EXEC SQL CLOSE C2;
}

return(retcd);
}

```

Output

This stored procedure returns the following output parameters, which are described in “[Option descriptions](#)” on page 700:

- *commands-executed*
- *IFI-return-code*
- *IFI-reason-code*
- *excess-bytes*
- *group-IFI-reason-code*
- *group-excess-bytes*
- *return-code*
- *message*

In addition to the preceding output, the stored procedure returns two result sets.

The first result set is returned in the created global temporary table SYSIBM.DB2_CMD_OUTPUT and contains the Db2 command output messages that were not parsed.

The following table shows the format of the first result set:

Table 111. Result set row for first ADMIN_COMMAND_DB2 result set

Column name	Data type	Contents
ROWNUM	INTEGER	Sequence number of the table row, from 1 to <i>n</i>
TEXT	CHAR(80)	Db2 command output message line

The format of the second result set varies, depending on the Db2 command issued and the *processing-type* value.

- [Result set row for second ADMIN_COMMAND_DB2 result set \(*processing-type* = "BP"\)](#)
- [Result set row for second ADMIN_COMMAND_DB2 result set \(*processing-type* = "THD"\)](#)
- [Result set row for second ADMIN_COMMAND_DB2 result set \(*processing-type* = "UT"\)](#)
- [Result set row for second ADMIN_COMMAND_DB2 result set \(*processing-type* = "DB" or "TS" or "IX"\)](#)
- [Result set row for second ADMIN_COMMAND_DB2 result set \(*processing-type* = "GRP"\)](#)
- [Result set row for second ADMIN_COMMAND_DB2 result set \(*processing-type* = "DDF"\)](#)

The following table shows the format of the result set returned in the created global temporary table SYSIBM.BUFFERPOOL_STATUS when *processing-type* = "BP":

Table 112. Result set row for second ADMIN_COMMAND_DB2 result set (processing-type = "BP")

Column name	Data type	Contents
ROWNUM	INTEGER	Sequence number of the table row, from 1 to <i>n</i>
BPNAME	CHAR(6)	Buffer pool name
VPSIZE	INTEGER	Buffer pool size
VPSEQT	INTEGER	Sequential steal threshold for the buffer pool
VPPSEQT	INTEGER	Parallel sequential threshold for the buffer pool
VPXPSEQT	INTEGER	Assisting parallel sequential threshold for the buffer pool
DWQT	INTEGER	Deferred write threshold for the buffer pool
PCT_VDWQT	INTEGER	Vertical deferred write threshold for the buffer pool (as a percentage of virtual buffer pool size)
ABS_VDWQT	INTEGER	Vertical deferred write threshold for the buffer pool (as absolute number of buffers)
PGSTEAL	CHAR(4)	Page-stealing algorithm that Db2 uses for the buffer pool
ID	INTEGER	Buffer pool internal identifier
USE_COUNT	INTEGER	The number of open table spaces or index spaces that reference this buffer pool
PGFIX	CHAR(3)	Specifies whether the buffer pool should be fixed in real storage when it is used
AUTOSIZE	VARCHAR(3)	Specifies whether automatic buffer pool adjustment is on or off
FRAMESIZE	VARCHAR(4)	The frame size that the buffer pool uses
ALLOC_FRAME4K	INTEGER	The number of buffers that are allocated with a 4K frame size
ALLOC_FRAME1M	INTEGER	The number of buffers that are allocated with a 1M frame size
VPSIZEMIN	INTEGER	The minimum buffer pool size
VPSIZEMAX	INTEGER	The maximum buffer pool size

The following table shows the format of the result set returned in the created global temporary table SYSIBM.DB2_THREAD_STATUS when *processing-type* = "THD":

Table 113. Result set row for second ADMIN_COMMAND_DB2 result set (processing-type = "THD")

Column name	Data type	Contents
ROWNUM	INTEGER	Sequence number of the table row, from 1 to <i>n</i>
TYPE	INTEGER	Thread type: 0 Unknown 1 Active 2 Inactive 3 Indoubt 4 Postponed
NAME	CHAR(8)	Connection name used to establish the thread
STATUS	CHAR(11)	Status of the conversation or socket
ACTIVE	CHAR(1)	Indicates whether a thread is active or not. An asterisk means that the thread is active within Db2.
REQ	CHAR(5)	Current number of Db2 requests on the thread
ID	CHAR(12)	Recovery correlation ID associated with the thread
AUTHID	CHAR(8)	Authorization ID associated with the thread
PLAN	CHAR(8)	Plan name associated with the thread
ASID	CHAR(4)	Address space identifier
TOKEN	CHAR(6)	Unique thread identifier
COORDINATOR	CHAR(46)	Name of the two-phase commit coordinator
RESET	CHAR(5)	Indicates whether or not the thread needs to be reset to purge info from the indoubt thread report
URID	CHAR(20)	Unit of recovery identifier
LUWID	CHAR(35)	Logical unit of work ID of the thread
WORKSTATION	VARCHAR(255)	Client workstation name
USERID	VARCHAR(128)	Client user ID

Table 113. Result set row for second ADMIN_COMMAND_DB2 result set (processing-type = "THD") (continued)

Column name	Data type	Contents
APPLICATION	VARCHAR(255)	Client application name
ACCOUNTING	VARCHAR(255)	Client accounting information.
LOCATION	VARCHAR(4050)	Location name of the remote system
DETAIL	VARCHAR(4050)	Additional thread information

The following table shows the format of the result set returned in the created global temporary table SYSIBM.UTILITY_JOB_STATUS when processing-type = "UT":

Table 114. Result set row for second ADMIN_COMMAND_DB2 result set (processing-type = "UT")

Column name	Data type	Contents
ROWNUM	INTEGER	Sequence number of the table row, from 1 to <i>n</i>
CSECT	CHAR(8)	Name of the command program CSECT that issued the message
USER	CHAR(8)	User ID of the person running the utility
MEMBER	CHAR(8)	Utility job is running on this member
UTILID	CHAR(16)	Utility job identifier
STATEMENT	INTEGER	Utility statement number
UTILITY	CHAR(20)	Utility name
PHASE	CHAR(20)	Utility restart from the beginning of this phase
COUNT	INTEGER	Number of pages or records processed in a utility phase
STATUS	CHAR(18)	Utility status
DETAIL	VARCHAR(4050)	Additional utility information
NUM_OBJ	INTEGER	Total number of objects in the list of objects the utility is processing
LAST_OBJ	INTEGER	Last object that started

The following table shows the format of the result set returned in the created global temporary table SYSIBM.DB_STATUS when processing-type = "DB" or "TS" or "IX":

Table 115. Result set row for second ADMIN_COMMAND_DB2 result set (processing-type = "DB" or "TS" or "IX")

Column name	Data type	Contents
ROWNUM	INTEGER	Sequence number of the table row, from 1 to <i>n</i>
DBNAME	CHAR(8)	Name of the database

Table 115. Result set row for second ADMIN_COMMAND_DB2 result set (processing-type = "DB" or "TS" or "IX") (continued)

Column name	Data type	Contents
SPACENAM	CHAR(8)	Name of the table space or index
TYPE	CHAR(2)	Status type: DB Database TS Table space IX Index
PART	SMALLINT	Individual partition or range of partition
STATUS	CHAR(18)	Status of the database, table space or index

The following table shows the format of the result set returned in the created global temporary table SYSIBM.DATA_SHARING_GROUP when *processing-type* = "GRP":

Table 116. Result set row for second ADMIN_COMMAND_DB2 result set (processing-type = "GRP")

Column name	Data type	Contents
ROWNUM	INTEGER	Sequence number of the table row, from 1 to <i>n</i>
DB2_MEMBER	CHAR(8)	Name of the Db2 group member
ID	INTEGER	ID of the Db2 group member
SUBSYS	CHAR(4)	Subsystem name of the Db2 group member
CMDPREF	CHAR(8)	Command prefix for the Db2 group member
STATUS	CHAR(8)	Status of the Db2 group member
DB2_LVL	CHAR(6)	Db2 version, release and modification level
SYSTEM_NAME	CHAR(8)	Name of the z/OS system where the member is running, or was last running in cases when the member status is QUIESCED or FAILED
IRLM_SUBSYS	CHAR(4)	Name of the IRLM subsystem to which the Db2 member is connected
IRLMPROC	CHAR(8)	Procedure name of the connected IRLM

The following table shows the format of the result set returned in the created global temporary table SYSIBM.DDF_CONFIG when *processing-type* = "DDF":

Table 117. Result set row for second ADMIN_COMMAND_DB2 result set (processing-type = "DDF")

Column name	Data type	Contents
ROWNUM	INTEGER NOT NULL	Sequence number of the table row, from 1 to <i>n</i>
STATUS	CHAR(6) NOT NULL	Operational status of DDF
LOCATION	CHAR(18) NOT NULL	Location name of DDF
LUNAME	CHAR(17) NOT NULL	Fully qualified LUNAME of DDF
GENERICLU	CHAR(17) NOT NULL	Fully qualified generic LUNAME of DDF
IPV4ADDR	CHAR(17) NOT NULL	IPV4 address of DDF
IPV6ADDR	CHAR(39)	IPV6 address of DDF
TCPPORT	INTEGER NOT NULL	SQL listener port used by DDF
RESPORT	INTEGER NOT NULL	Resync listener port used by DDF
SQL_DOMAIN	CHAR(45) NOT NULL	Domain name associated with the IP address in IPV4ADDR or IPV6ADDR
RSYNC_DOMAIN	CHAR(45)	Domain name associated with a specific member IP address
SECPORT	INTEGER	Secure SQL listener TCP/IP port number
IPNAME	CHAR(8)	IPNAME used by DDF
ALIASNAME1	CHAR(18)	An alias name value specified in the BSDS DDF record.
ALIASPORT1	INTEGER	TCP/IP port associated with ALIASNAME1
ALIASSECPORT1	INTEGER	Secure TCP/IP port associated with ALIASNAME1
ALIASNAME2	CHAR(18)	An alias name value specified in the BSDS DDF record
ALIASPORT2	INTEGER	TCP/IP port associated with ALIASNAME2

Table 117. Result set row for second ADMIN_COMMAND_DB2 result set (processing-type = "DDF")
(continued)

Column name	Data type	Contents
ALIASSECPOR2	INTEGER	Secure TCP/IP port associated with ALIASNAME2
ALIASNAME3	CHAR(18)	An alias name value specified in the BSDS DDF record
ALIASPORT3	INTEGER	TCP/IP port associated with ALIASNAME3
ALIASSECPOR3	INTEGER	Secure TCP/IP port associated with ALIASNAME3
ALIASNAME4	CHAR(18)	An alias name value specified in the BSDS DDF record
ALIASPORT4	INTEGER	TCP/IP port associated with ALIASNAME4
ALIASSECPOR4	INTEGER	Secure TCP/IP port associated with ALIASNAME4
ALIASNAME5	CHAR(18)	An alias name value specified in the BSDS DDF record
ALIASPORT5	INTEGER	TCP/IP port associated with ALIASNAME5
ALIASSECPOR5	INTEGER	Secure TCP/IP port associated with ALIASNAME5
ALIASNAME6	CHAR(18)	An alias name value specified in the BSDS DDF record
ALIASPORT6	INTEGER	TCP/IP port associated with ALIASNAME6
ALIASSECPOR6	INTEGER	Secure TCP/IP port associated with ALIASNAME6
ALIASNAME7	CHAR(18)	An alias name value specified in the BSDS DDF record
ALIASPORT7	INTEGER	TCP/IP port associated with ALIASNAME7
ALIASSECPOR7	INTEGER	Secure TCP/IP port associated with ALIASNAME7
ALIASNAME8	CHAR(18)	An alias name value specified in the BSDS DDF record
ALIASPORT8	INTEGER	TCP/IP port associated with ALIASNAME8
ALIASSECPOR8	INTEGER	Secure TCP/IP port associated with ALIASNAME8
MEMBER_IPV4ADDR	CHAR(17)	IPV4 address associated with the specific member of a data sharing group

Table 117. Result set row for second ADMIN_COMMAND_DB2 result set (processing-type = "DDF") (continued)

Column name	Data type	Contents
MEMBER_IPV6ADDR	CHAR(39)	IPV6 address associated with the specific member of a data sharing group

GUPI

ADMIN_COMMAND_DSN stored procedure

The SYSPROC.ADMIN_COMMAND_DSN stored procedure executes a BIND, REBIND, FREE, or DCLGEN DSN subcommand and returns the output from the DSN subcommand execution.

Environment

GUPI

ADMIN_COMMAND_DSN runs in a WLM-established stored procedures address space. TCB=1 is also required.

Authorization

To execute the CALL statement, the owner of the package or plan that contains the CALL statement must have one or more of the following privileges:

- The EXECUTE privilege on the ADMIN_COMMAND_DSN stored procedure
- Ownership of the stored procedure
- SYSADM authority

To execute the DSN subcommand, you must use a privilege set that includes the authorization to execute the DSN subcommand.

Syntax

The following syntax diagram shows the SQL CALL statement for invoking this stored procedure:

```
► CALL — SYSPROC.ADMIN_COMMAND_DSN — ( — DSN-subcommand , — message — ) ◄
```

Option descriptions

DSN-subcommand

Specifies the DSN subcommand to be executed. If the DSN subcommand passed to the stored procedure is not BIND, REBIND, FREE, or DCLGEN, an error message is returned. The DSN subcommand is performed using the authorization ID of the user who invoked the stored procedure.

ADMIN_COMMAND_DSN does not support three-part names if a wildcard character is specified in the package name.

This parameter is case sensitive. You must specify *DSN-subcommand* in uppercase characters.

This is an input parameter of type VARCHAR(32704) and cannot be null.

message

Contains messages if an error occurs during stored procedure execution.

The stored procedure might not return a result set if *message* is not blank. Even if *message* is not blank, the stored procedure might return a result set if the error described in *message* occurred after the stored procedure executed at least one DSN subcommand, and the stored procedure can successfully insert the DSN subcommand output message in the result set and open the result set cursor.

A blank *message* does not mean that the DSN subcommand completed successfully. The calling application must read the result set to determine if the DSN subcommand was successful or not.

This is an output parameter of type VARCHAR(1331).

Example

The following C language sample shows how to invoke ADMIN_COMMAND_DSN:

```
#include <stdio.h>
#include <stdlib.h>
#include <string.h>

/***** DB2 SQL Communication Area *****/
EXEC SQL INCLUDE SQLCA;

int main( int argc, char *argv[] ) /* Argument count and list */
{
    /***** DB2 Host Variables *****/
    EXEC SQL BEGIN DECLARE SECTION;

    /* SYSPROC.ADMIN_COMMAND_DSN parameters */

    char      subcmd[32705];          /* BIND, REBIND, FREE, or */
                                      /* DCLGEN DSN subcommand */
    char      errmsg[1332];          /* Error message */

    /* Result set locators */
    volatile SQL TYPE IS RESULT_SET_LOCATOR *rs_loc1;

    /* Result set row */
    long int   rownum;                /* Sequence number of the */
                                      /* table row */
    char       text[256];              /* DSN subcommand output row */
    EXEC SQL END DECLARE SECTION;

    /***** Set input parameter to execute a REBIND PLAN DSN subcommand */
    strcpy(subcmd, "REBIND PLAN (DSNACCOB) FLAG(W)");

    /***** Call stored procedure SYSPROC.ADMIN_COMMAND_DSN */
    EXEC SQL CALL SYSPROC.ADMIN_COMMAND_DSN (:subcmd, :errmsg);

    /***** Retrieve result set when the SQLCODE from the call is +446, */
    /* which indicates that result sets were returned */
    if (SQLCODE == +466) /* Result sets were returned */
    {
        /* Establish a link between the result set and its locator */
        EXEC SQL ASSOCIATE LOCATORS (:rs_loc1)
            WITH PROCEDURE SYSPROC.ADMIN_COMMAND_DSN;

        /* Associate a cursor with the result set */
        EXEC SQL ALLOCATE C1 CURSOR FOR RESULT SET :rs_loc1;

        /* Perform fetches using C1 to retrieve all rows from the */
        /* result set */
        EXEC SQL FETCH C1 INTO :rownum, :text;
        while(SQLCODE==0)
        {
            EXEC SQL FETCH C1 INTO :rownum, :text;
        }

        EXEC SQL CLOSE C1;
    }
}
```

```
    return;  
}
```

Output

This stored procedure returns an error message, *message*, if an error occurs.

The stored procedure returns one result set that contains the DSN subcommand output messages.

The following table shows the format of the result set returned in the created global temporary table SYSIBM.DSN_SUBCMD_OUTPUT:

Table 118. Result set row for ADMIN_COMMAND_DSN result set

Column name	Data type	Contents
ROWNUM	INTEGER	Sequence number of the table row, from 1 to <i>n</i>
TEXT	VARCHAR(255)	DSN subcommand output message line

GUPI

Related reference

[DSN command \(TSO\) \(Db2 Commands\)](#)

Related information

[About Db2 and related commands \(Db2 Commands\)](#)

ADMIN_COMMAND_MVS stored procedure

The SYSPROC.ADMIN_COMMAND_MVS stored procedure issues the QUERY COPYPOOL, LIST COPYPOOL, Db2 START, Db2 STOP, DUMP, or DISPLAY WLM command.

Environment

GUPI

The load module for the ADMIN_COMMAND_MVS stored procedure, DSNADMCM, must reside in an APF-authorized library. The ADMIN_COMMAND_MVS stored procedure runs in a WLM-established stored procedures address space, and all of the libraries that are specified in the STEPLIB DD statement must be APF-authorized.

Authorization

To execute the CALL statement, the owner of the package or plan that contains the CALL statement must have one or more of the following privileges:

- The EXECUTE privilege on the stored procedure
- Ownership of the stored procedure
- SYSADM authority

ADMIN_COMMAND_MVS uses an extended MCS console to issue the requested command.

The caller of ADMIN_COMMAND_MVS must have READ access to the MVS.MCSOPER.* or MVS.MCSOPER.xxxxxxxx (where xxxxxxxx is the name of the extended console) resource profile of the RACF OPERCMDS class. By default, unless overwritten by CONSNAME which is specified in the *subparameters* input parameter of ADMIN_COMMAND_MVS, the name of the extended MCS console is DSNADMCM. If MVS.MCSOPER.xxxxxxxx exists, the ADMIN_COMMAND_MVS caller must have READ access to this profile. Otherwise, the caller must have READ access to MVS.MCSOPER.*.

In the OPERPARM segment of the extended MCS console's user profile (defined in a security product, such as RACF), specify the following console attributes:

- STORAGE= 512 or higher
- AUTH= ALL
- UD= NO
- HC= NO
- INTIDS= NO
- UNKNIDS= NO

You must also set the ROUTCODE, LEVEL, and MSCOPE console attributes. The attributes that you specify depend on the type of command:

START DB2, STOP DB2, DISPLAY WLM, LIST COPYPOOL, or QUERY COPYPOOL commands

Specify:

- ROUTCODE=NONE
- LEVEL=NB
- MSCOPE=*

DUMP command

Specify:

- ROUTCODE=ALL
- LEVEL=NB ALL
- MSCOPE=*

STOP DB2 command when Db2 is already stopping

Specify:

- ROUTCODE=ALL
- LEVEL=NB ALL
- MSCOPE=*ALL

Important: Specify ROUTCODE=ALL and MSCOPE=*ALL only when you anticipate that Db2 is already stopping when the STOP DB2 command is issued by ADMIN_COMMAND_MVS, and plan to increase the STORAGE value in these cases.

If the OPERPARM segment of the extended MCS console's user profile is not defined, default values are applied for all console attributes, except for the following attributes:

- STORAGE=512
- AUTH=ALL
- LEVEL=NB
- MSCOPE=*

For more information about controlling attributes for users of extended MCS consoles, see [Defining console attributes for extended MCS consoles \(z/OS MVS Planning: Operations\)](#).

The extended MCS console must be authorized to execute the requested command.

Syntax

The following syntax diagram shows the SQL CALL statement for invoking this stored procedure:

```

CALL ADMIN_COMMAND_MVS ( type , command_prefix ,
remote_system , jobname , command ,
parameters , subparameters , wait_timeout ,
return-code , command_completion_code , message )

```

Option descriptions

type

Specifies the type of command to be issued.

Valid values are:

- HSM
- DB2
- DUMP
- WLM

This parameter is an input parameter of type VARCHAR(24) and cannot be null.

command_prefix

Specifies the command prefix that identifies which Db2 subsystem to direct the command to.

This parameter is an input parameter of type VARCHAR(8).

You cannot specify null for this parameter if the *type* parameter is set to Db2.

remote_system

Specifies the z/OS system to which the Db2 command is to be routed.

This parameter is an input parameter of type VARCHAR(8).

You cannot specify null for this parameter if both of the following conditions apply:

- Db2 is the *type* parameter
- The Db2 command will be routed to a z/OS system that is different from the system where the stored procedure is executing

jobname

Specifies the name of the batch job or started task to be modified.

This parameter is an input parameter of type VARCHAR(8).

You cannot specify null for this parameter if HSM is the *type* parameter.

command

Specifies the command to be executed.

Valid values depend on the value of the *type* parameter.

- When the *type* parameter is set to Db2, valid values are:
 - START

- STOP
- When the *type* parameter is set to DUMP, the valid value is DUMP.
- When the *type* parameter is set to HSM, valid values are:
 - QUERY COPYPOOL
 - LIST COPYPOOL
- When the *type* parameter is set to WLM, the valid value is DISPLAY.

This parameter is an input parameter of type VARCHAR(126) and cannot be null.

parameters

Specifies the parameters of the command, or the program parameters that will be passed to the started task.

Valid values depend on the value of the *command* parameter.

This parameter is an input parameter of type VARCHAR(124).

You cannot specify null for this parameter if the *type* parameter is set to HSM, DUMP, or WLM.

subparameters

Specifies the sub-parameters of the command. The following keyword-value pairs are supported:

CONSNM=*console-name*

The name of the console that the stored procedure activates. If not specified, the default is DSNADMCM. The specified console must not already be active.

IRLMPROC=*procedure-name*

The procedure name of the connected IRLM. The stored procedure performs the following actions if IRLMPPROC is specified:

- If Db2 is already stopping when the stored procedure issues the STOP DB2 command, it starts monitoring IRLM termination after the DSN9022I message is received.
- If Db2 is not stopped or is not already stopping when the stored procedure issues the STOP DB2 command, it starts monitoring IRLM termination after message DSN3100I is received.

Monitoring occurs within the specified *wait-timeout period* and ends when the IRLM address space terminates or the wait timeout period expires. The stored procedure reports Db2 normal termination only after it determines that IRLM address space is terminated.

The IRLM procedure name is 1–8 characters. The first character must be a letter A–Z, #, \$, or @; the remaining characters can be A through Z, 0–9, or #, \$, or @.

This keyword-value pair can only be specified when the *type* parameter is Db2, the *command* parameter is STOP, and the SSNM keyword is not specified.

SSNM=*subsystem-name*

The Db2 subsystem name. The stored procedure performs the following actions:

- If Db2 is already stopping when the stored procedure issues the STOP DB2 command, it starts monitoring *ssnm*MSTR termination after the DSN9022I message is received.
- If Db2 is not stopped or is not already stopping when the stored procedure issues the STOP DB2 command, the keyword is ignored and no monitoring of *ssnm*MSTR termination occurs.

Monitoring occurs within the specified *wait-timeout period* and ends when the system services address space (*ssnm*MSTR) terminates or the wait timeout period expires. The stored procedure reports Db2 normal termination only after it determines that the *ssnm*MSTR address space is terminated.

The subsystem name is 1–4 characters. The first character must be a letter A–Z, #, \$, or @; the remaining characters can be A through Z, 0–9, or #, \$, or @.

This keyword-value pair can be specified only when the *type* parameter is Db2, the *command* parameter is STOP, and the IRLMPROC keyword is not specified.

LIST_CP_KEYWORDS=DUMPVOLS

This keyword-value pair can be specified only when the *type* parameter is HSM and the *command* parameter is LIST COPYPOOL.

QUERY_CP_BACKUP=number-of-versions

The number of copy pool backup versions. This key-value pair can be specified only when the *command* parameter is set to QUERY COPYPOOL.

Alternatively, if no key-value pairs specified for *subparameters*, the following values are supported:

- DUMPVOLS, when the *command* parameter is LIST COPYPOOL.
- The number of copy pool backup versions, when *command* parameter is QUERY COPYPOOL.

This parameter is an input parameter of type VARCHAR(124).

You cannot specify null for this parameter if both of the following conditions apply:

- The *type* parameter is set to HSM
- The *command* parameter is set to QUERY COPYPOOL

wait_timeout

Specifies the amount of time (in seconds) that this procedure waits for the command to complete and for the message to be routed to the console. If the console is already active, the wait time includes the time that the procedure waits for the console to become available. If stopping Db2 and the IRLM or *ssnmMSTR* address space termination is being monitored, the wait time includes the time the procedure monitors the status of these address spaces.

For Db2 START and Db2 STOP, valid values are 1-900, and the default wait time is 180 seconds. Otherwise, valid values are 1-120, and the default wait time is 5 seconds.

This parameter is an input parameter of type INTEGER.

return_code

Provides the return code from the stored procedure.

Possible values are:

0

The stored procedure did not encounter any errors during processing. However, this return code does not indicate that the command executed successfully. The *command_completion_code* output parameter indicates whether the command executed successfully or not.

4

The stored procedure issued the command but was unable to determine the command execution status based on the command messages that were retrieved within the prescribed wait time. For example, the wait time might have expired.

When *return_code* is 4, the *command_completion_code* parameter is set to 8 or 16.

All command messages that were retrieved within the prescribed wait time are returned in the result set.

8

The stored procedure issued the command but was unable to determine the command execution status because it was unable to retrieve all the command messages that were queued to the extended MCS console. When *return_code* is 8, the *command_completion_code* parameter is set to 8 or 16. All the command messages that were retrieved so far are returned in the result set. For STOP DB2, the latest IRLM address space (*irlmproc*) or system services address space (*ssnmMSTR*) status information (from the 'D A' output) is also returned in the result set if IRLM address space (*irlmproc*) or system services address space (*ssnmMSTR*) termination monitoring was performed successfully. For STOP DB2, the latest IRLM address space (*irlmproc*) or Db2 system services address space (*ssnmMSTR*) status information (from the 'D A' output) is also returned in the result set if IRLM or MSTR termination monitoring was performed successfully.

12

The stored procedure encountered an error during processing. The *message* output parameter contains messages that describe the error.

This parameter is an output parameter of type INTEGER.

command_completion_code

Indicates the completion status of the command.

Possible values are:

0

One of the following conditions applies:

- The command completed successfully.
- If the *command* parameter is QUERY COPYPOOL, there is no FlashCopy® process that is active in the background.

For details about *command_completion_code* 0, see [Table 119 on page 719](#).

4

One of the following conditions applies:

- The command was not processed. For example, Db2 was already stopped when STOP DB2 was requested.
- If the *command* parameter is QUERY COPYPOOL, one or more FlashCopy processes are active in the background.

For details about *command_completion_code* 4, see [Table 120 on page 720](#).

8

The command started but the completion status is unknown. For details about *command_completion_code* 8, see [Table 121 on page 721](#).

12

The command completed abnormally. For details about *command_completion_code* 12, see [Table 122 on page 723](#).

16

The command output does not satisfy the conditions that are listed for *command_completion_code* 0, 4, 8, or 12.

This parameter is an output parameter of type INTEGER.

The following tables describe the messages that ADMIN_COMMAND_MVS looks for when assigning a specific value to *command_completion_code*.

Table 119. Description of command_completion_code 0

Command	Command completion code description	Messages received
DISPLAY WLM	DISPLAY WLM completed successfully.	Message IWM029I was received.
DUMP	DUMP completed successfully.	Both of the following messages were received: <ul style="list-style-type: none"> • IEA794I • IEA911E or IEA611I

Table 119. Description of command_completion_code 0 (continued)

Command	Command completion code description	Messages received
LIST COPYPOOL	The list of copy pools that was output by LIST COPYPOOL is complete.	Both of the following messages were received: <ul style="list-style-type: none"> COPYPOOL=xx...xx, where xx...xx is the name of the copy pool that is specified in the <i>parameters</i> input parameter ARC0140I
QUERY COPYPOOL	No FlashCopy processes are active in the background.	Message ARC1821I was received. The number of copy pool backup versions (as specified in the <i>subparameters</i> input parameter) and the number of copy pool versions that are not in active FlashCopy relationships is the same. Message ARC1820I was not received.
START DB2	START DB2 completed successfully.	Message DSN9022I <i>cmd_prefix</i> was received, which indicates that Db2 START completed normally.
STOP DB2	STOP DB2 completed successfully.	<ul style="list-style-type: none"> DSN3100I <i>cmd_prefix</i> Message 'irlm_procname NOT FOUND' was found in the 'D A, irlm_procname' command output when the stored procedure checked the IRLM address space status.

Table 120. Description of command_completion_code 4

Command	Command completion code description	Messages received
QUERY COPYPOOL	One or more FlashCopy processes are active in the background.	One or more ARC1820I messages and zero or more ARC1821I messages were received. The number of copy pool backup versions (as specified in the <i>subparameters</i> input parameter) and the number of copy pool versions that are in active and not in active FlashCopy relationships is the same.
START DB2	Db2 is already active when the command was issued.	Message DSNY003I <i>cmd_prefix</i> was received.
STOP DB2	One of the following scenarios applies: <ul style="list-style-type: none"> Db2 was already stopped when the command was issued. Db2 was in the process of stopping when the command was issued, and it stopped successfully. 	<p>Db2 was already stopped:</p> <ul style="list-style-type: none"> DSN3106I <i>cmd_prefix</i> <p>Db2 was in the process of stopping:</p> <ul style="list-style-type: none"> DSNY004I <i>cmd_prefix</i> and DSN9022I <i>cmd_prefix</i>, where DSN9022I <i>cmd_prefix</i> indicates that Db2 STOP completed normally, and either message 'ssnmMSTR NOT FOUND' was found in the 'D A, ssnmMSTR' command output when the stored procedure checked the ssnmMSTR address space status, or message 'irlm_procname NOT FOUND' was found in the 'D A, irlm_procname' command output when the stored procedure checked the IRLM address space status.

Table 121. Description of *command_completion_code* 8

Command	Command completion code description	Messages received	Expected completion messages not received
DUMP	The dump was captured but not written.	Message IEA794I was received.	One of the following messages was not received: <ul style="list-style-type: none"> • IEA911E • IEA611I
LIST COPYPOOL	The listing from LIST COPYPOOL is truncated.	Message COPYPOOL=xx...xxx was received, where xx...xx is the name of the copy pool that is specified in the <i>parameters</i> input parameter.	Message ARC0140I was not received.
QUERY COPYPOOL	One or more FlashCopy processes are active or not active in the background.	One or more ARC1820I or ARC1821I messages was received.	The total number of ARC1820I and ARC1821I messages is not equal to the total number of copy pool backup versions that is specified in the <i>subparameters</i> input parameter.
START DB2	Db2 is in the process of starting, but the completion status of START DB2 is unknown.	Message DSNY024I <i>cmd_prefix</i> was received.	One of the following messages was not received: <ul style="list-style-type: none"> • DSN9023I <i>cmd_prefix</i> • DSNV086E <i>cmd_prefix</i> • DSN3104I <i>cmd_prefix</i> • DSN9022I <i>cmd_prefix</i>, which indicates that Db2 START completed normally • DSN3100I <i>cmd_prefix</i>

Table 121. Description of *command_completion_code* 8 (continued)

Command	Command completion code description	Messages received	Expected completion messages not received
STOP DB2	Db2 is in the process of stopping, but the completion status of STOP DB2 is unknown.	<p>One of the following messages was received:</p> <ul style="list-style-type: none"> • DSNY002I <i>cmd_prefix</i> • DSNY004I <i>cmd_prefix</i> 	<p>DSNY002I <i>cmd_prefix</i> received:</p> <ul style="list-style-type: none"> • None of the following messages were received: <ul style="list-style-type: none"> – DSN3100I <i>cmd_prefix</i> – DSN3107I <i>cmd_prefix</i> – DSN9023I <i>cmd_prefix</i> – Or, message DSN3100I <i>cmd_prefix</i> was received but message 'irlm_procname NOT FOUND' was not found in the 'D A, irlm_procname' command output when the stored procedure checked the IRLM address soace status. <p>DSNY004I <i>cmd_prefix</i> received:</p> <ul style="list-style-type: none"> • None of the following messages were received: <ul style="list-style-type: none"> – DSN9022I <i>cmd_prefix</i>, which indicates that Db2 STOP completed normally – DSN9023I <i>cmd_prefix</i> • Or, message DSN9022I <i>cmd_prefix</i> was received but either message 'irlm_procname NOT FOUND' was not found in the 'D A, irlm_procname' command output when the stored procedure checked the IRLM address space status, or message 'ssnmMSTR NOT FOUND' was not found in the 'D A, ssnmMSTR' command output when the stored procedure checked the ssnmMSTR address space status.

Table 122. Description of `command_completion_code` 12

Command	Command completion code description	Messages received
DISPLAY WLM	DISPLAY WLM completed abnormally.	One of the following messages was received: <ul style="list-style-type: none"> • IWM002I • IWM003I • IWM030I
LIST COPYPOOL	No output was generated from LIST COPYPOOL.	Message ARC0140I was received, but message COPYPOOL=xx...xxx was not received, where xx...xxx is the name of the copy pool that is specified in the <i>parameters</i> input parameter.
START DB2	START DB2 completed abnormally.	One of the following messages was received: <ul style="list-style-type: none"> • DSN9023I <i>cmd_prefix</i> • DSNV086E <i>cmd_prefix</i> • DSN3106I <i>cmd_prefix</i> • DSN3107I <i>cmd_prefix</i> • DSN3104I <i>cmd_prefix</i> • DSN3100I <i>cmd_prefix</i>
STOP DB2	STOP DB2 completed abnormally.	One of the following messages was received: <ul style="list-style-type: none"> • DSN3107I <i>cmd_prefix</i> • DSN9023I <i>cmd_prefix</i>

message

Contains messages that describe the error that was encountered by the stored procedure.

This parameter is an output parameter of type VARCHAR(1331).

Example

The following C language example shows how to invoke ADMIN_COMMAND_MVS.

```
#include <stdio.h>
#include <stdlib.h>
#include <string.h>
/***** DB2 SQL Communication Area *****/
EXEC SQL INCLUDE SQLCA;
int main( int argc, char *argv[] ) /* Argument count and list */
{
/***** DB2 Host Variables *****/
EXEC SQL BEGIN DECLARE SECTION;
/* SYSPROC.ADMIN_COMMAND_MVS parameters */
EXEC SQL BEGIN DECLARE SECTION;
/* SYSPROC.ADMIN_COMMAND_MVS parameters */
char ptype[25]; /* Command type */
char pcprefix[9]; /* DB2 subsystem command prefix */
char prmtsys[9]; /* Remote system */
char pjobnm[9]; /* Started task job name */
char pcmd[127]; /* Command to be executed */
char pparms[125]; /* Command parameters */
char psubparms[125]; /* Command subparameters */
long int pwait; /* Command completion wait time */
long int prc; /* Return code */
long int pccc; /* Command completion code */
char pmsg[1332]; /* Error message */

short int ind_ptype; /* Indicator variable */
```

```

short int  ind_pcprefix;          /* Indicator variable */
short int  ind_prmtsys;          /* Indicator variable */
short int  ind_pjobnm;          /* Indicator variable */
short int  ind_pcmd;            /* Indicator variable */
short int  ind_pparms;          /* Indicator variable */
short int  ind_psubparms;       /* Indicator variable */
short int  ind_pwait;           /* Indicator variable */
short int  ind_prc;             /* Indicator variable */
short int  ind_pccc;            /* Indicator variable */
short int  ind_pmsg;            /* Indicator variable */

/* Result set locators */
volatile SQL TYPE IS RESULT_SET_LOCATOR *rs_loc1;
/* Result set row */
long int   rownum;              /* Sequence number of the
                               /* table row
char       text[2001];          /* Message
EXEC SQL END DECLARE SECTION;
/*****
/* Clear temporary table SYSIBM.MVS_CMD_OUTPUT */
EXEC SQL DELETE FROM SYSIBM.MVS_CMD_OUTPUT;
/*****
/* Set procedure input parameters */
/*****
strcpy(ptype, "WLM");
strcpy(pcmd, "DISPLAY");
strcpy(pparms, "APPLENV=*");
ind_ptype = 0;
ind_pcprefix = -1;
ind_prmtsys = -1;
ind_pjobnm = -1;
ind_pcmd = 0;
ind_pparms = 0;
ind_psubparms = -1;
ind_pwait = -1;
/*****
/* Call stored procedure SYSPROC.ADMIN_COMMAND_MVS */
/*****
EXEC SQL CALL SYSPROC.ADMIN_COMMAND_MVS (
        :ptype:ind_ptype,
        :pcprefix:ind_pcprefix,
        :prmtsys:ind_prmtsys,
        :pjobnm:ind_pjobnm,
        :pcmd:ind_pcmd,
        :pparms:ind_pparms,
        :psubparms:ind_psubparms,
        :pwait:ind_pwait,
        :prc:ind_prc,
        :pccc:ind_pccc,
        :pmsg:ind_pmsg);
/*****
/* Retrieve result set when the SQLCODE from the call is +446,
/* which indicates that result sets were returned */
/*****
if (SQLCODE == +446)          /* Result sets were returned */
{
/* Establish a link between the result set and its locator */
EXEC SQL ASSOCIATE LOCATORS (:rs_loc1)
        WITH PROCEDURE SYSPROC.ADMIN_COMMAND_MVS;
/* Associate a cursor with the result set */
EXEC SQL ALLOCATE C1 CURSOR FOR RESULT SET :rs_loc1;
/* Perform fetches using C1 to retrieve all rows from the
/* result set */
EXEC SQL FETCH C1 INTO :rownum, :text;
        while(SQLCODE==0)
        {
                EXEC SQL FETCH C1 INTO :rownum, :text;
        }
}
return;
}

```

Output

This stored procedure returns the following output parameters, which are described in [“Option descriptions”](#) on page 716:

- *return-code*

- `command_completion_code`
- `message`

In addition to the preceding output, the stored procedure returns one result set that contains the command messages. For STOP DB2, the latest IRLM or Db2 `ssnmMSTR` address space status information (from the 'D A' output) is also returned in the result set if IRLM or MSTR termination monitoring was performed successfully.

For Db2 START, Db2 STOP, and DUMP commands, both solicited messages (which are command responses) and unsolicited messages (which are other system messages) are retrieved and returned. Otherwise, only solicited messages are returned.

The following table shows the format of the result set that is returned in the created global temporary table `SYSIBM.MVS_CMD_OUTPUT`:

Table 123. Result set row for `ADMIN_COMMAND_MVS` result set

Column name	Data type	Contents
ROWNUM	INTEGER NOT NULL	Sequence number of the table row (1...n)
TEXT	VARCHAR(2000) NOT NULL	A command message line



ADMIN_COMMAND_UNIX stored procedure

The `SYSPROC.ADMIN_COMMAND_UNIX` stored procedure executes a z/OS UNIX System Services command and returns the output.

Environment



`ADMIN_COMMAND_UNIX` runs in a WLM-established stored procedure address space.

The load module for `ADMIN_COMMAND_UNIX`, `DSNADMCU`, must be program controlled if the `BPX.DAEMON.HFCTL FACILITY` class profile has not been set up. For information on how to define `DSNADMCU` to program control, see installation job `DSNTIJRA`.

Authorization

To execute the `CALL` statement, the owner of the package or plan that contains the `CALL` statement must have one or more of the following privileges on each package that the stored procedure uses:

- The `EXECUTE` privilege on the package for `DSNADMCU`
- Ownership of the package
- `PACKADM` authority for the package collection
- `SYSADM` authority

The user specified in the `user-ID` input parameter of the SQL `CALL` statement must have the appropriate authority to execute the z/OS UNIX System Services command.

Syntax

The following syntax diagram shows the SQL `CALL` statement for invoking this stored procedure:

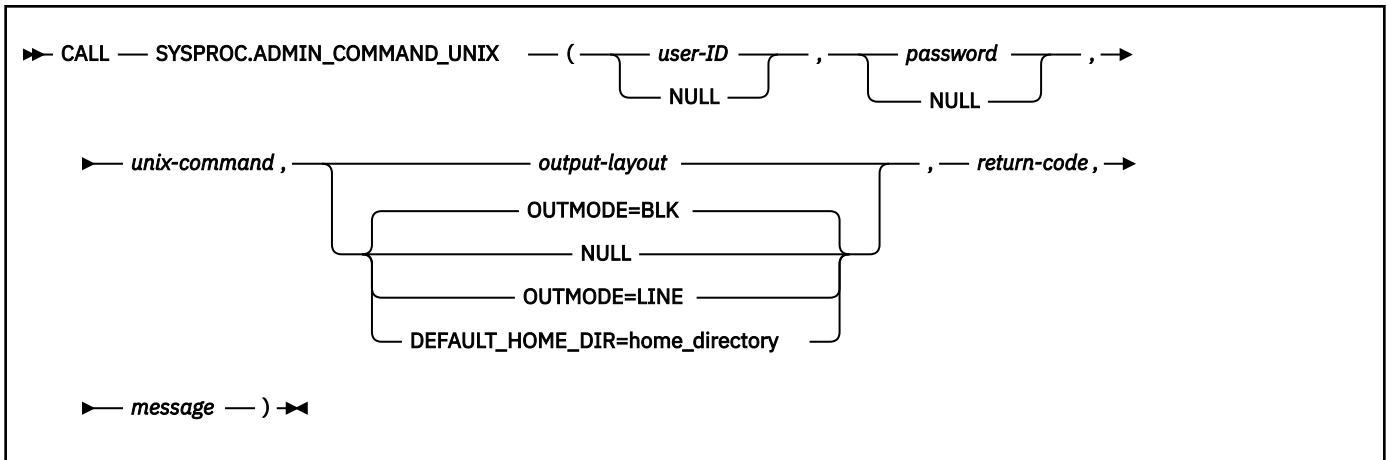

Option descriptions

user-ID

Specifies the user ID under which the z/OS UNIX System Services command is issued.

If *user-ID* is NULL, *password* must also be NULL. If the *user-ID* and *password* values are NULL, the login process uses the primary authorization ID of the process.

You can specify NULL for this parameter in the following circumstances:

- The authorization ID that is associated with the stored procedure address space has daemon authority.
- The authorization ID that is associated with the stored procedure address space does not have daemon authority but is authorized to the BPX.SRV.*userid* SURROGAT class profile, where *userid* is the authorization ID of the stored procedure. For more information about how the RACF security administrator can authorize the authorization ID that is associated with the stored procedure address space to a SURROGAT class profile, see [Defining servers to process users without passwords or password phrases](#).

Daemon authority is given to any superuser that is permitted to the BPX.DAEMON FACILITY class profile. If the BPX.DAEMON FACILITY class profile is not defined, all superusers have daemon authority.

This is an input parameter of type VARCHAR(128).

password

Specifies the password associated with the input parameter *user-ID*.

The value of *password* is passed to the stored procedure as part of payload, and is not encrypted. It is not stored in dynamic cache when parameter markers are used.

If *password* is NULL, *user-ID* must also be NULL. If the *user-ID* and *password* values are NULL, the login process uses the primary authorization ID of the process.

You can specify NULL for this parameter in the following circumstances:

- The authorization ID that is associated with the stored procedure address space has daemon authority.
- The authorization ID that is associated with the stored procedure address space does not have daemon authority but is authorized to the BPX.SRV.*userid* SURROGAT class profile, where *userid* is the authorization ID of the stored procedure.

This is an input parameter of type VARCHAR(100).

unix-command

Specifies the z/OS UNIX System Services command to be executed.

This is an input parameter of type VARCHAR(32704) and cannot be null.

output-layout

Specifies how the output from the z/OS UNIX System Services command is returned and the default home directory of the specified *user-ID*.

The output from the z/OS UNIX System Services command is a multi-line message. Possible values are:

OUTMODE=LINE

Each line is returned as a row in the result set.

OUTMODE=BLK

The lines are blocked into 32677 blocks and each block is returned as a row in the result set.

You specify the default home directory for *user-ID* as follows:

DEFAULT_HOME_DIR=home_directory

If the home directory of the specified *user-ID* does not exist, or *user-ID* does not have a home directory, the SYSPROC.ADMIN_COMMAND_UNIX stored procedure runs the command under the default home directory that you specify.

The maximum length of *home_directory* is 1007.

If you need to specify both OUTMODE and DEFAULT_HOME_DIR, consider the following examples:

```
OUTMODE=LINE,DEFAULT_HOME_DIR=/tmp
```

```
DEFAULT_HOME_DIR=/tmp,OUTMODE=LINE
```

If a null or empty string is provided, the default option OUTMODE=BLK is used.

This is an input parameter of type VARCHAR(1024).

return-code

Provides the return code from the stored procedure. Possible values are:

0

The call completed successfully.

4

The stored procedure used the default home directory.

12

The call did not complete successfully. The *message* output parameter contains messages describing the error.

This is an output parameter of type INTEGER.

message

Contains messages describing the error encountered by the stored procedure. If no error occurred, then no message is returned.

The first messages in this area are generated by the stored procedure. Messages that are generated by Db2 might follow the first messages.

This is an output parameter of type VARCHAR(1331).

Example

The following C language sample shows how to invoke ADMIN_COMMAND_UNIX:

```
#include <stdio.h>
#include <stdlib.h>
#include <string.h>

/***** DB2 SQL Communication Area *****/
EXEC SQL INCLUDE SQLCA;

int main( int argc, char *argv[] ) /* Argument count and list */
{
```

```

/***** DB2 Host Variables *****/
EXEC SQL BEGIN DECLARE SECTION;

/* SYSPROC.ADMIN_COMMAND_UNIX parameters */
char      userid[129];          /* User ID */
short int ind_userid;          /* Indicator variable */
char      password[101];       /* Password */
short int ind_password;       /* Indicator variable */
char      command[32705];      /* USS command */
short int ind_command;        /* Indicator variable */
char      layout[1025];        /* Command output layout */
short int ind_layout;         /* Indicator variable */
long int  retcd;               /* Return code */
short int ind_retcd;          /* Indicator variable */
char      errmsg[1332];        /* Error message */
short int ind_errmsg;         /* Indicator variable */

/* Result set locators */
volatile SQL TYPE IS RESULT_SET_LOCATOR *rs_loc1;

/* Result set row */
long int  rownum;              /* Sequence number of the
                               /* table row */
char      text[32678];         /* A row in USS command output*/
EXEC SQL END DECLARE SECTION;

/*****
/* Assign values to input parameters to execute a USS command */
/* Set the indicator variables to 0 for non-null input parameters */
/* Set the indicator variables to -1 for null input parameters */
*****/
strcpy(userid, "USRT001");
ind_userid = 0;
strcpy(password, "N1CETEST");
ind_password = 0;
strcpy(command, "ls");
ind_command = 0;
ind_layout = -1;

/*****
/* Call stored procedure SYSPROC.ADMIN_COMMAND_UNIX */
*****/
EXEC SQL CALL SYSPROC.ADMIN_COMMAND_UNIX
              (:userid      :ind_userid,
              :password    :ind_password,
              :command     :ind_command,
              :layout      :ind_layout,
              :retcd       :ind_retcd,
              :errmsg      :ind_errmsg);

/*****
/* Retrieve result set when the SQLCODE from the call is +446,
/* which indicates that result sets were returned */
*****/
if (SQLCODE == +446) /* Result sets were returned */
{
  /* Establish a link between the result set and its locator */
  EXEC SQL ASSOCIATE LOCATORS (:rs_loc1)
        WITH PROCEDURE SYSPROC.ADMIN_COMMAND_UNIX;

  /* Associate a cursor with the result set */
  EXEC SQL ALLOCATE C1 CURSOR FOR RESULT SET :rs_loc1;

  /* Perform fetches using C1 to retrieve all rows from the
  /* result set */
  EXEC SQL FETCH C1 INTO :rownum, :text;
  while(SQLCODE==0)
  {
    EXEC SQL FETCH C1 INTO :rownum, :text;
  }

  EXEC SQL CLOSE C1;
}

return(retcd);
}

```

Output

This stored procedure returns the following output parameters, which are described in “[Option descriptions](#)” on page 726:

- *return-code*
- *message*

In addition to the preceding output, the stored procedure returns one result set that contains the z/OS UNIX System Services command output messages.

The following table shows the format of the result set returned in the created global temporary table SYSIBM.USS_CMD_OUTPUT:

Table 124. Result set row for ADMIN_COMMAND_UNIX result set

Column name	Data type	Contents
ROWNUM	INTEGER	Sequence number of the table row, from 1 to <i>n</i>
TEXT	VARCHAR(32677)	A block of text or a line from the output messages of a z/OS UNIX System Services command



ADMIN_DS_BROWSE stored procedure

The SYSPROC.ADMIN_DS_BROWSE stored procedure returns either text or binary records from certain data sets or their members. You can browse a physical sequential (PS) data set, a generation data set, a partitioned data set (PDS) member, or a partitioned data set extended (PDSE) member. This stored procedure supports only data sets with LRECL=80 and RECFM=FB.

Environment



The load module for ADMIN_DS_BROWSE, DSNADMDB, must reside in an APF-authorized library. ADMIN_DS_BROWSE runs in a WLM-established stored procedures address space, and all libraries in this WLM procedure STEPLIB DD concatenation must be APF-authorized.

Authorization

To execute the CALL statement, the owner of the package or plan that contains the CALL statement must have one or more of the following privileges on each package that the stored procedure uses:

- The EXECUTE privilege on the package for DSNADMDB
- Ownership of the package
- PACKADM authority for the package collection
- SYSADM authority

The ADMIN_DS_BROWSE caller also needs authorization from an external security system, such as RACF, in order to browse or view an z/OS data set resource.

Syntax

The following syntax diagram shows the SQL CALL statement for invoking this stored procedure:

```
► CALL — SYSPROC.ADMIN_DS_BROWSE — ( — data-type, — data-set-name, — member-name, —►  
► — dump-option, — return-code, — message — ) ►
```

Option descriptions

data-type

Specifies the type of data to be browsed and how the data set will be allocated. Possible values are:

- 1**
Text data with exclusive access
- 2**
Binary data with exclusive access
- 3**
Text data with shared access. This value is valid only if browsing a library member.
- 4**
Binary data with shared access. This value is valid only if browsing a library member.

This is an input parameter of type INTEGER and cannot be null.

data-set-name

Specifies the name of the data set, or of the library that contains the member to be browsed. Possible values are:

PS data set name

If reading from a PS data set, the *data-set-name* contains the name of the PS data set.

PDS or PDSE name

If reading from a member that belongs to this PDS or PDSE, the *data-set-name* contains the name of the PDS or PDSE.

GDS name

If reading from a generation data set, the *data-set-name* contains the name of the generation data set, such as USERGDG.FILE.G0001V00.

This is an input parameter of type CHAR(44) and cannot be null.

member-name

Specifies the name of the PDS or PDSE member, if reading from a PDS or PDSE member. Otherwise, a blank character.

This is an input parameter of type CHAR(8) and cannot be null.

dump-option

Specifies whether to use the Db2 standard dump facility to dump the information necessary for problem diagnosis when an SQL error occurred or when a call to the IBM routine IEFDB476 to get messages about an unsuccessful SVC 99 call failed.

Possible values are:

- Y**
Generate a dump.
- N**
Do not generate a dump.

This is an input parameter of type CHAR(1) and cannot be null.

return-code

Provides the return code from the stored procedure. Possible values are:

- 0**
The call completed successfully.

12

The call did not complete successfully. The *message* output parameter contains messages describing the error.

This is an output parameter of type INTEGER.

message

Contains messages describing the error encountered by the stored procedure. If no error occurred, then no message is returned.

The first messages in this area are generated by the stored procedure. Messages that are generated by Db2 or by z/OS might follow the first messages.

This is an output parameter of type VARCHAR(1331).

Example

The following C language sample shows how to invoke ADMIN_DS_BROWSE:

```
#include <stdio.h>
#include <stdlib.h>
#include <string>

/***** DB2 SQL Communication Area *****/
EXEC SQL INCLUDE SQLCA;

int main( int argc, char *argv[] ) /* Argument count and list */
{
    /***** DB2 Host Variables *****/
    EXEC SQL BEGIN DECLARE SECTION;

    /* SYSPROC.ADMIN_DS_BROWSE parameters */
    long int datatype; /* Data type */
    char dsname[45]; /* Data set name */
    char mbrname[9]; /* Library member name */
    char dumpopt[2]; /* Dump option */
    long int retcd; /* Return code */
    char errmsg[1332]; /* Error message */

    /* Result set locators */
    volatile SQL TYPE IS RESULT_SET_LOCATOR *rs_loc1;

    /* Result set row */
    long int rownum; /* Sequence number of the */
    /* table row */
    char text_rec[81]; /* A data set record */
    EXEC SQL END DECLARE SECTION;

    /***** Assign values to input parameters to browse a library member *****/
    datatype = 1;
    strcpy(dsname, "USER.DATASET.PDS");
    strcpy(mbrname, "MEMBER0A");
    strcpy(dumpopt, "N");

    /***** Call stored procedure SYSPROC.ADMIN_DS_BROWSE *****/
    EXEC SQL CALL SYSPROC.ADMIN_DS_BROWSE
        (:datatype, :dsname, :mbrname, :dumpopt,
         :retcd, :errmsg);

    /***** Retrieve result set when the SQLCODE from the call is +446, *****/
    /* which indicates that result sets were returned */
    /***** Result sets were returned *****/
    if (SQLCODE == +446)
    {
        /* Establish a link between the result set and its locator */
        EXEC SQL ASSOCIATE LOCATORS (:rs_loc1)
            WITH PROCEDURE SYSPROC.ADMIN_DS_BROWSE;

        /* Associate a cursor with the result set */
        EXEC SQL ALLOCATE C1 CURSOR FOR RESULT SET :rs_loc1;

        /* Perform fetches using C1 to retrieve all rows from the */
    }
}
```

```

/* result set
EXEC SQL FETCH C1 INTO :rownum, :text_rec;
while(SQLCODE==0)
{
EXEC SQL FETCH C1 INTO :rownum, :text_rec;
}
EXEC SQL CLOSE C1;
}
return(retcd);
}
*/

```

Output

This stored procedure returns the following output parameters, which are described in “[Option descriptions](#)” on page 730:

- *return-code*
- *message*

In addition to the preceding output, the stored procedure returns one result set that contains the text or binary records read.

The following table shows the format of the result set returned in the created global temporary table SYSIBM.TEXT_REC_OUTPUT containing text records read:

Table 125. Result set row for ADMIN_DS_BROWSE result set (text records)

Column name	Data type	Contents
ROWNUM	INTEGER	Sequence number of the table row, from 1 to <i>n</i> .
TEXT_REC	VARCHAR(80)	Record read (text format).

The following table shows the format of the result set returned in the created global temporary table SYSIBM.BIN_REC_OUTPUT containing binary records read:

Table 126. Result set row for ADMIN_DS_BROWSE result set (binary records)

Column name	Data type	Contents
ROWNUM	INTEGER	Sequence number of the table row, from 1 to <i>n</i> .
BINARY_REC	VARCHAR(80) FOR BIT DATA	Record read (binary format).



ADMIN_DS_DELETE stored procedure

The SYSPROC.ADMIN_DS_DELETE stored procedure deletes certain data sets or their members. You can delete a physical sequential (PS) data set, a partitioned data set (PDS), a partitioned data set extended (PDSE), a generation data set (GDS), or a member of a PDS or PDSE.

Environment



The load module for ADMIN_DS_DELETE, DSNADMDD, must reside in an APF-authorized library. ADMIN_DS_DELETE runs in a WLM-established stored procedures address space, and all libraries in this WLM procedure STEPLIB DD concatenation must be APF-authorized.

Authorization

To execute the CALL statement, the owner of the package or plan that contains the CALL statement must have one or more of the following privileges:

- The EXECUTE privilege on the ADMIN_DS_DELETE stored procedure
- Ownership of the stored procedure
- SYSADM authority

The ADMIN_DS_DELETE caller also needs authorization from an external security system, such as RACF, in order to delete an z/OS data set resource.

Syntax

The following syntax diagram shows the SQL CALL statement for invoking this stored procedure:

```
▶▶ CALL — SYSPROC.ADMIN_DS_DELETE — ( — data-set-type , — data-set-name , →  
▶ — parent-data-set-name , — dump-option , — return-code , — message — ) ▶▶
```

Option descriptions

data-set-type

Specifies the type of data set to delete. Possible values are:

- 1** Partitioned data set (PDS)
- 2** Partitioned data set extended (PDSE)
- 3** Member of a PDS or PDSE
- 4** Physical sequential data set (PS)
- 6** Generation data set (GDS)

This is an input parameter of type INTEGER and cannot be null.

data-set-name

Specifies the name of the data set, library member, or GDS absolute generation number to be deleted. Possible values are:

PS, PDS, or PDSE name

If *data-set-type* is 1, 2, or 4, the *data-set-name* contains the name of the PS, PDS, or PDSE to be deleted.

PDS or PDSE member name

If *data-set-type* is 3, the *data-set-name* contains the name of the PDS or PDSE member to be deleted.

absolute generation number

If *data-set-type* is 6, the *data-set-name* contains the absolute generation number of the GDS to be deleted, such as G0001V00.

This is an input parameter of type CHAR(44) and cannot be null.

parent-data-set-name

Specifies the name of the library that contains the member to be deleted, or of the GDG that contains the GDS to be delete. Otherwise blank. Possible values are:

blank

If *data-set-type* is 1, 2, or 4, the *parent-data-set-name* is left blank.

PDS or PDSE name

If *data-set-type* is 3, the *parent-data-set-name* contains the name of the PDS or PDSE whose member is to be deleted.

GDG name

If *data-set-type* is 6, the *parent-data-set-name* contains the name of the GDG that the GDS to be deleted belongs to.

This is an input parameter of type CHAR(44) and cannot be null.

dump-option

Specifies whether to use the Db2 standard dump facility to dump the information necessary for problem diagnosis when a call to the IBM routine IEFDB476 to get messages about an unsuccessful SVC 99 call failed.

Possible values are:

Y

Generate a dump.

N

Do not generate a dump.

This is an input parameter of type CHAR(1) and cannot be null.

return-code

Provides the return code from the stored procedure. Possible values are:

0

Data set, PDS member, PDSE member, or GDS was deleted successfully.

12

The call did not complete successfully. The *message* output parameter contains messages describing the error.

This is an output parameter of type INTEGER.

message

Contains messages describing the error encountered by the stored procedure. If no error occurred, then no message is returned.

The first messages in this area are generated by the stored procedure. Messages that are generated by z/OS might follow the first messages.

This is an output parameter of type VARCHAR(1331).

Example

The following C language sample shows how to invoke ADMIN_DS_DELETE:

```
#include <stdio.h>
#include <stdlib.h>
#include <string.h>

/***** DB2 SQL Communication Area *****/
EXEC SQL INCLUDE SQLCA;

int main( int argc, char *argv[] ) /* Argument count and list */
{
  /***** DB2 Host Variables *****/
  EXEC SQL BEGIN DECLARE SECTION;

  /* SYSPROC.ADMIN_DS_DELETE parameters */
  long int  dstype; /* Data set type */
  char      dsname[45]; /* Data set name , */
  /* member name, or */
  /* generation # (G0001V00) */
  char      parentds[45]; /* PDS, PDSE, GDG or blank */
  char      dumpopt[2]; /* Dump option */
}
```

```

long int    retcd;                /* Return code          */
char       errmsg[1332];        /* Error message       */
EXEC SQL END DECLARE SECTION;

/*****
/* Assign values to input parameters to delete a data set
*****/
dstype = 4;
strcpy(dsname, "USER.DATASET.PDS");
strcpy(parentds, " ");
strcpy(dumpopt, "N");

/*****
/* Call stored procedure SYSPROC.ADMIN_DS_DELETE
*****/
EXEC SQL CALL SYSPROC.ADMIN_DS_DELETE
              (:dstype, :dsname, :parentds, :dumpopt,
              :retcd, :errmsg);

return(retcd);
}

```

Output

This stored procedure returns the following output parameters, which are described in [“Option descriptions”](#) on page 733:

- *return-code*
- *message*



ADMIN_DS_LIST stored procedure

The SYSPROC.ADMIN_DS_LIST stored procedure returns a list of data set names, a generation data group (GDG), a partitioned data set (PDS) member, a partitioned data set extended (PDSE) member, or generation data sets of a GDG.

Environment



The load module for ADMIN_DS_LIST, DSNADMDL, must reside in an APF-authorized library. ADMIN_DS_LIST runs in a WLM-established stored procedures address space, and all libraries in this WLM procedure STEPLIB DD concatenation must be APF-authorized.

Authorization

To execute the CALL statement, the owner of the package or plan that contains the CALL statement must have one or more of the following privileges on each package that the stored procedure uses:

- The EXECUTE privilege on the package for DSNADMDL
- Ownership of the package
- PACKADM authority for the package collection
- SYSADM authority

The ADMIN_DS_LIST caller also needs authorization from an external security system, such as RACF, in order to perform the requested operation on an z/OS data set resource.

Syntax

The following syntax diagram shows the SQL CALL statement for invoking this stored procedure:

```
► CALL — SYSPROC.ADMIN_DS_LIST — ( — data-set-name , — list-members , — list-generations , —  
► — max-results , — dump-option , — return-code , — message — ) ►
```

Option descriptions

data-set-name

Specifies the data set name. You can use masking characters, except for when you list members of a PDS/PDSE (*list-members* = 'Y') or the generation data sets of a GDG (*list-generations* = 'Y'). For example: USER.* or USER.A*CD. In addition, the specified data set name cannot start with a masking character.

If no masking characters are used, only one data set will be listed.

This is an input parameter of type CHAR(44) and cannot be null.

list-members

Specifies whether to list PDS or PDSE members. Possible values are:

Y

List members. Only set to Y when *data-set-name* is a fully qualified PDS or PDSE.

N

Do not list members.

This is an input parameter of type CHAR(1) and cannot be null.

list-generations

Specifies whether to list generation data sets. Possible values are:

Y

List generation data sets. Only set to Y when *data-set-name* is a fully qualified GDG.

N

Do not list generation data sets.

This is an input parameter of type CHAR(1) and cannot be null.

max-results

Specifies the maximum number of result set rows. This option is applicable only when both *list-members* and *list-generations* are 'N'.

This is an input parameter of type INTEGER and cannot be null.

dump-option

Specifies whether to use the Db2 standard dump facility to dump the information necessary for problem diagnosis when any of the following errors occur:

- SQL error.
- A call to the IBM routine IEFDB476 to get messages about an unsuccessful SVC 99 call failed.
- Load Catalog Search Interface module error.

Possible values are:

Y

Generate a dump.

N

Do not generate a dump.

This is an input parameter of type CHAR(1) and cannot be null.

return-code

Provides the return code from the stored procedure. Possible values are:

0

The call completed successfully.

4

Processing completed, but some data sets received catalog management errors. Data set information is returned for the data sets that did not receive catalog management errors. Error information is returned for the data sets that received catalog management errors.

12

The call did not complete successfully. The *message* output parameter contains messages describing the error.

This is an output parameter of type INTEGER.

message

Contains messages describing the error encountered by the stored procedure. If no error occurred, then no message is returned.

The first messages in this area are generated by the stored procedure. Messages that are generated by Db2 or by z/OS might follow the first messages.

This is an output parameter of type VARCHAR(1331).

Example

The following C language sample shows how to invoke ADMIN_DS_LIST:

```
#pragma csect(CODE,"SAMDLPGM")
#pragma csect(STATIC,"PGMDLSAM")
#pragma runopts(plist(os))

#include <stdio.h>
#include <stdlib.h>
#include <string.h>

/***** DB2 SQL Communication Area *****/
EXEC SQL INCLUDE SQLCA;

int main( int argc, char *argv[] ) /* Argument count and list */
{
  /***** DB2 Host Variables *****/
  EXEC SQL BEGIN DECLARE SECTION;

  /* SYSPROC.ADMIN_DS_LIST parameters */
  char dsname[45]; /* Data set name or filter */
  char listmbr[2]; /* List library members */
  char listgds[2]; /* List GDS */
  long int maxresult; /* Maximum result set rows */
  char dumpopt[2]; /* Dump option */
  long int retcd; /* Return code */
  char errmsg[1332]; /* Error message */

  /* Result set locators */
  volatile SQL TYPE IS RESULT_SET_LOCATOR *rs_loc1;

  /* Result set row */
  char dsnamer[45]; /* Data set name, */
  /* library member name, or */
  /* absolute generation number */
  long int createyr; /* Create year */
  long int createday; /* Create day */
  long int type; /* Data set type */
  char volume[7]; /* Data set volume */
  long int primaryext; /* Size of first extent */
  long int secondext; /* Size of secondary extent */
  char measure[10]; /* Extent unit of measurement */
  long int extinuse; /* Current allocated extents */
  char dasduse[9]; /* DASD usage */
  char harba[7]; /* High allocated RBA */
  char hurba[7]; /* High used RBA */
  char encrypttype[3]; /* Encryption type */
  char encryptkeylabel[65]; /* Encryption key label */
  EXEC SQL END DECLARE SECTION;

  char * ptr;
```

```

int i = 0;
/*****
/* Assign values to input parameters to list all members of
/* a library
*****/
strcpy(dsname, "USER.DATASET.PDS");
strcpy(listmbr, "Y");
strcpy(listgds, "N");
maxresult = 1;
strcpy(dumpopt, "N");

/*****
/* Call stored procedure SYSPROC.ADMIN_DS_LIST
*****/
EXEC SQL CALL SYSPROC.ADMIN_DS_LIST
           (:dsname, :listmbr, :listgds, :maxresult,
           :dumpopt, :retcd, :errmsg);

/*****
/* Retrieve result set when the SQLCODE from the call is +446,
/* which indicates that result sets were returned
*****/
if (SQLCODE == +466) /* Result sets were returned
{
  /* Establish a link between the result set and its locator
  EXEC SQL ASSOCIATE LOCATORS (:rs_loc1)
        WITH PROCEDURE SYSPROC.ADMIN_DS_LIST;

  /* Associate a cursor with the result set
  EXEC SQL ALLOCATE C1 CURSOR FOR RESULT SET :rs_loc1;

  /* Perform fetches using C1 to retrieve all rows from the
  /* result set
  EXEC SQL FETCH C1 INTO :dsnamer, :createyr, :createday,
                        :type, :volume, :primaryext,
                        :secondext, :measure, :extinuse,
                        :dasduse, :harba, :hurba;
                        :encrypttype; :encryptkeylabel;

  while(SQLCODE==0)
  {
    EXEC SQL FETCH C1 INTO :dsnamer, :createyr, :createday,
                          :type, :volume, :primaryext,
                          :secondext, :measure, :extinuse,
                          :dasduse, :harba, :hurba;
                          :encrypttype; :encryptkeylabel;

  }

  EXEC SQL CLOSE C1;
}

return(retcd);
}

```

Output

This stored procedure returns the following output parameters, which are described in [“Option descriptions”](#) on page 736:

- *return-code*
- *message*

In addition to the preceding output, the stored procedure returns one result set that contains the list of data sets, GDGs, PDS or PDSE members, or generation data sets that were requested.

The following table shows the format of the result set:

Table 127. Result set row for ADMIN_DS_LIST result set

Column name	Data type	Contents
DSNAME	VARCHAR(44)	<ul style="list-style-type: none"> • Data set name, if <i>list-members</i> is "N" and <i>list-generations</i> is "N". • Member name, if <i>list-members</i> is "Y". • Absolute generation number (of the form G0000V00) from a generation data set name, if <i>list-generations</i> is "Y".
CREATE_YEAR	INTEGER	The year that the data set was created. Not applicable for member and VSAM cluster.
CREATE_DAY	INTEGER	The day of the year that the data set was created, as an integer in the range of 1 to 366 where 1 represents January 1). Not applicable for member and VSAM cluster.
TYPE	INTEGER	<p>Type of data set. Possible values are:</p> <p>0 Unknown type of data set</p> <p>1 PDS data set</p> <p>2 PDSE data set</p> <p>3 Member of PDS or PDSE</p> <p>4 Physical sequential data set</p> <p>5 Generation data group</p> <p>6 Generation data set</p> <p>8 VSAM cluster</p> <p>9 VSAM data component</p> <p>10 VSAM index component</p>
VOLUME	CHAR(6)	Volume where data set resides. Not applicable for member and VSAM cluster.
PRIMARY_EXTENT	INTEGER	Size of first extent. Not applicable for member and VSAM cluster.

Table 127. Result set row for ADMIN_DS_LIST result set (continued)

Column name	Data type	Contents
SECONDARY_EXTENT	INTEGER	Size of secondary extent. Not applicable for member and VSAM cluster.
MEASUREMENT_UNIT	CHAR(9)	Unit of measurement for first extent and secondary extent. Possible values are: <ul style="list-style-type: none"> • BLOCKS • BYTES • CYLINDERS • KB • MB • TRACKS Not applicable for member and VSAM cluster.
EXTENTS_IN_USE	INTEGER	Current allocated extents. Not applicable for member and VSAM cluster.
DASD_USAGE	CHAR(8) FOR BIT DATA	Disk usage. For VSAM data and VSAM index only.
HARBA	CHAR(6) FOR BIT DATA	High allocated RBA. For VSAM data and VSAM index only.
HURBA	CHAR(6) FOR BIT DATA	High used RBA. For VSAM data and VSAM index only.
ERRMSG	VARCHAR(256)	An error message that explains the first data set-related failure that was encountered by the stored procedure while gathering the attributes of a data set. Some possible error messages are DSNA661I, DSNA662I, and DSNA635I. If an error did not occur while gathering data set attributes, this column is blank.
ENCRYPT_TYPE	CHAR(2) FOR BIT DATA	The encryption type. x'0100' The data set is encrypted. x'FFFF' The data set is not encrypted
ENCRYPT_KEY_LABEL	VARCHAR(64)	Encryption key label. If the data set is not encrypted, 64 bytes of hex 'FF' is returned.

When a data set spans more than one volume, one row is returned for each volume that contains a piece of the data set. The VOLUME, EXTENTS_IN_USE, DASD_USAGE, HARBA, and HURBA columns reflect information for the specified volume.

If a data set entry error is encountered, the ADMIN_DS_LIST stored procedure returns the data set that caused the error in the result set, along with data sets that did not have errors. In the result set, the attribute columns for the data set that caused the error are set to specific values, as shown in the following table.

Table 128. Values of data set attributes when an error is encountered

Attribute	Value
CREATE_YEAR	0
CREATE_DAY	0
TYPE	0
VOLUME	blank
PRIMARY_EXTENT	-1
SECONDARY_EXTENT	-1
MEASUREMENT_UNIT	blank
EXTENTS_IN_USE	-1
DASD_USAGE	-1 (x'FFFFFFFFFFFFFFFF')
HARBA	-1 (x'FFFFFFFFFFFFFF')
HURBA	-1 (x'FFFFFFFFFFFFFF')
ENCRYPT_TYPE	-1 (x'FFFF')
ENCRYPT_KEY_LABEL	-1 (x'FF..FF' with 64 FF pairs.)

GUPI

ADMIN_DS_RENAME stored procedure

The SYSPROC.ADMIN_DS_RENAME stored procedure renames a physical sequential (PS) data set, a partitioned data set (PDS), a partitioned data set extended (PDSE), or a member of a PDS or PDSE.

Environment

GUPI

The load module for ADMIN_DS_RENAME, DSNADMDR, must reside in an APF-authorized library. ADMIN_DS_RENAME runs in a WLM-established stored procedures address space, and all libraries in this WLM procedure STEPLIB DD concatenation must be APF-authorized.

Authorization

To execute the CALL statement, the owner of the package or plan that contains the CALL statement must have one or more of the following privileges:

- The EXECUTE privilege on the ADMIN_DS_RENAME stored procedure
- Ownership of the stored procedure
- SYSADM authority

The ADMIN_DS_RENAME caller also needs authorization from an external security system, such as RACF, in order to rename an z/OS data set resource.

Syntax

The following syntax diagram shows the SQL CALL statement for invoking this stored procedure:

```
▶▶ CALL — SYSPROC.ADMIN_DS_RENAME — ( — data-set-type , — data-set-name , →  
▶ — parent-data-set-name , — new-data-set-name , — dump-option , — return-code , — message →  
▶ — ) ▶▶
```

Option descriptions

data-set-type

Specifies the type of data set to rename. Possible values are:

- 1** Partitioned data set (PDS)
- 2** Partitioned data set extended (PDSE)
- 3** Member of a PDS or PDSE
- 4** Physical sequential data set (PS)

This is an input parameter of type INTEGER and cannot be null.

data-set-name

Specifies the data set or member to be renamed. Possible values are:

PS, PDS, or PDSE name

If *data-set-type* is 1, 2, or 4, the *data-set-name* contains the name of the PS, PDS, or PDSE to be renamed.

PDS or PDSE member name

If *data-set-type* is 3, the *data-set-name* contains the name of the PDS or PDSE member to be renamed.

This is an input parameter of type CHAR(44) and cannot be null.

parent-data-set-name

Specifies the name of the PDS or PDSE, if renaming a PDS or PDSE member. Otherwise, a blank character. Possible values are:

blank

If *data-set-type* is 1, 2, or 4, the *parent-data-set-name* is left blank.

PDS or PDSE name

If *data-set-type* is 3, the *parent-data-set-name* contains the name of the PDS or PDSE whose member is to be renamed.

This is an input parameter of type CHAR(44) and cannot be null.

new-data-set-name

Specifies the new data set or member name. Possible values are:

new data set name

If *data-set-type* is 1, 2, or 4, the *new-data-set-name* contains the new data set name.

new member name

If *data-set-type* is 3, the *new-data-set-name* contains the new member name.

This is an input parameter of type CHAR(44) and cannot be null.

dump-option

Specifies whether to use the Db2 standard dump facility to dump the information necessary for problem diagnosis when any of the following errors occurred:

- A call to the IBM routine IEFDB476 to get messages about an unsuccessful SVC 99 call failed.
- Load IDCAMS program error.

Possible values are:

Y

Generate a dump.

N

Do not generate a dump.

This is an input parameter of type CHAR(1) and cannot be null.

return-code

Provides the return code from the stored procedure. Possible values are:

0

The data set, PDS member, or PDSE member was renamed successfully.

12

The call did not complete successfully. The *message* output parameter contains messages describing the error.

This is an output parameter of type INTEGER.

message

Contains messages based on *return-code* and *data-set-type* combinations.

<i>return-code</i>	<i>data-set-type</i>	Content
0	1, 2, or 4	Contains IDCAMS messages.
0	3	No message is returned.
Not 0	not applicable	Contains messages describing the error encountered by the stored procedure. The first messages are generated by the stored procedure and messages that are generated by z/OS might follow these first messages. The first messages can also be generated by z/OS.

This is an output parameter of type VARCHAR(1331).

Example

The following C language sample shows how to invoke ADMIN_DS_RENAME:

```
#include <stdio.h>
#include <stdlib.h>
#include <string.h>

/***** DB2 SQL Communication Area *****/
EXEC SQL INCLUDE SQLCA;

int main( int argc, char *argv[] ) /* Argument count and list */
{
  /***** DB2 Host Variables *****/
  EXEC SQL BEGIN DECLARE SECTION;

  /* SYSPROC.ADMIN_DS_RENAME parameters */
  long int  dstype; /* Data set type */
  char      dsname[45]; /* Data set or member name */
  char      parentds[45]; /* Parent data set (PDS or
                          /* PDSE) name or blank */
  char      newdsname[45]; /* New data set or member name*/
  char      dumpopt[2]; /* Dump option */
  long int  retcd; /* Return code */
  char      errmsg[1332]; /* Error message */
  EXEC SQL END DECLARE SECTION;

  /***** Assign values to input parameters to rename a library member */
  /***** *****/
  dstype = 3;
  strcpy(dsname, "MEMBER01");
  strcpy(parentds, "USER.DATASET.PDS");
  strcpy(newdsname, "MEMBER0A");
  strcpy(dumpopt, "N");

  /***** Call stored procedure SYSPROC.ADMIN_DS_RENAME */
  /***** *****/
  EXEC SQL CALL SYSPROC.ADMIN_DS_RENAME
              (:dstype, :dsname, :parentds, :newdsname,
              :dumpopt, :retcd, :errmsg);

  return(retcd);
}
```

Output

This stored procedure returns the following output parameters, which are described in [“Option descriptions”](#) on page 742:

- *return-code*
- *message*



ADMIN_DS_SEARCH stored procedure

The SYSPROC.ADMIN_DS_SEARCH stored procedure determines if certain data sets are cataloged, or if a library member of a cataloged data set exists. You can search for a physical sequential (PS) data set, a partitioned data set (PDS), a partitioned data set extended (PDSE), a generation data group (GDG), a generation data set (GDS), or the library member of a cataloged PDS or PDSE.

Environment



The load module for ADMIN_DS_SEARCH, DSNADMDE, must reside in an APF-authorized library. ADMIN_DS_SEARCH runs in a WLM-established stored procedures address space, and all libraries in this WLM procedure STEPLIB DD concatenation must be APF-authorized.

Authorization

To execute the CALL statement, the owner of the package or plan that contains the CALL statement must have one or more of the following privileges:

- The EXECUTE privilege on the ADMIN_DS_SEARCH stored procedure
- Ownership of the stored procedure
- SYSADM authority

The ADMIN_DS_SEARCH caller also needs authorization from an external security system, such as RACF, in order to perform the requested operation on an z/OS data set resource.

Syntax

The following syntax diagram shows the SQL CALL statement for invoking this stored procedure:

```
►► CALL — SYSPROC.ADMIN_DS_SEARCH — ( — data-set-name , — member-name , — dump-option , ►►  
► — data-set-exists , — return-code , — message — ) ►►
```

Option descriptions

data-set-name

Specifies the name of a PS data set, PDS, PDSE, GDG or GDS.

This is an input parameter of type CHAR(44) and cannot be null.

member-name

Specifies the name of a PDS or PDSE member. Set this parameter to a blank character if you only want to check the existence of the PDS or PDSE.

This is an input parameter of type CHAR(8) and cannot be null.

dump-option

Specifies whether to use the Db2 standard dump facility to dump the information necessary for problem diagnosis when any of the following errors occurred:

- A call to the IBM routine IEFDB476 to get messages about an unsuccessful SVC 99 call failed.
- Load IDCAMS program error.

Possible values are:

Y

Generate a dump.

N

Do not generate a dump.

This is an input parameter of type CHAR(1) and cannot be null.

data-set-exists

Indicates whether a data set or library member exists or not. Possible values are:

-1

Call did not complete successfully. Unable to determine if data set or member exists.

0

Data set or member was found

1

Data set not found

2

PDS or PDSE member not found

This is an output parameter of type INTEGER.

return-code

Provides the return code from the stored procedure. Possible values are:

0

The call completed successfully.

12

The call did not complete successfully. The *message* output parameter contains messages describing the error.

This is an output parameter of type INTEGER.

message

Contains IDCAMS messages if *return-code* is 0. Otherwise, contains messages describing the error encountered by the stored procedure. The first messages are generated by the stored procedure and messages that are generated by z/OS might follow these first messages.

This is an output parameter of type VARCHAR(1331).

Example

The following C language sample shows how to invoke ADMIN_DS_SEARCH:

```
#include <stdio.h>
#include <stdlib.h>
#include <string.h>

/***** DB2 SQL Communication Area *****/
EXEC SQL INCLUDE SQLCA;

int main( int argc, char *argv[] ) /* Argument count and list */
{
    /***** DB2 Host Variables *****/
    EXEC SQL BEGIN DECLARE SECTION;

    /* SYSPROC.ADMIN_DS_SEARCH parameters */
    char dsname[45]; /* Data set name or GDG */
    char mbrname[9]; /* Library member name */
    char dumpopt[2]; /* Dump option */
    long int exist; /* Data set or library member */
    /* existence indicator */
    long int retcd; /* Return code */
    char errmsg[1332]; /* Error message */
    EXEC SQL END DECLARE SECTION;

    /***** Assign values to input parameters to determine whether a
    /* library member exists or not */
    /***** */
    strcpy(dsname, "USER.DATASET.PDS");
    strcpy(mbrname, "MEMBER0A");
    strcpy(dumpopt, "N");

    /***** Call stored procedure SYSPROC.ADMIN_DS_SEARCH */
    /***** */
    EXEC SQL CALL SYSPROC.ADMIN_DS_SEARCH
                (:dsname, :mbrname, :dumpopt,
                :exist, :retcd, :errmsg);

    return(retcd);
}
```

Output

This stored procedure returns the following output parameters, which are described in [“Option descriptions” on page 745](#):

- *data-set-exists*
- *return-code*

- *message*

GUI

ADMIN_DS_WRITE stored procedure

The SYSPROC.ADMIN_DS_WRITE stored procedure writes either text or binary records that are passed in a global temporary table to data sets or their members. You can write to a physical sequential (PS) data set, a partitioned data set (PDS) member, a partitioned data set extended (PDSE) member, or a generation data set (GDS).

This stored procedure can either append or replace an existing PS data set, PDS or PDSE member, or GDS. Also, this stored procedure can create a new PS data set, PDS or PDSE data set or member, or a new GDS for an existing generation data group (GDG) as needed. This stored procedure supports only data sets with LRECL=80 and RECFM=FB.

Environment

GUI

The load module for ADMIN_DS_WRITE, DSNADMDW, must reside in an APF-authorized library. ADMIN_DS_WRITE runs in a WLM-established stored procedures address space, and all libraries in this WLM procedure STEPLIB DD concatenation must be APF-authorized.

Authorization

To execute the CALL statement, the owner of the package or plan that contains the CALL statement must have one or more of the following privileges on each package that the stored procedure uses:

- The EXECUTE privilege on the package for DSNADMDW
- Ownership of the package
- PACKADM authority for the package collection
- SYSADM authority

The ADMIN_DS_WRITE caller also needs authorization from an external security system, such as RACF, in order to write to an z/OS data set resource.

Syntax

The following syntax diagram shows the SQL CALL statement for invoking this stored procedure:

```

▶▶ CALL — SYSPROC.ADMIN_DS_WRITE — ( — data-type, — data-set-name, — member-name, —▶
    — processing-option, — dump-option, — return-code, — message — ) ▶▶

```

Option descriptions

This stored procedure takes the following input options:

data-type

Specifies the type of data to be saved. Possible values are:

- 1** Text data
- 2** Binary data

This is an input parameter of type INTEGER and cannot be null.

data-set-name

Specifies the name of the data set, GDG that contains the GDS, or library that contains the member, to be written to. Possible values are:

PS data set name

Name of the PS data set, if writing to a PS data set.

GDG name

Name of the GDG, if writing to a GDS within this GDG.

PDS or PDSE name

Name of the PDS or PDSE, if writing to a member that belongs to this library.

This is an input parameter of type CHAR(44) and cannot be null.

member-name

Specifies the relative generation number of the GDS, if writing to a GDS, or the name of the PDS or PDSE member, if writing to a PDS or PDSE member. Otherwise, a blank character. Possible values are:

GDS relative generation number

Relative generation number of a GDS, if writing to a GDS. For example: -1, 0, +1

PDS or PDSE member name

Name of the PDS or PDSE member, if writing to a library member.

blank

In all other cases, blank.

This is an input parameter of type CHAR(8) and cannot be null.

processing-option

Specifies the type of operation. Possible values are:

R

Replace

A

Append

NM

New member

ND

New PS, PDS, PDSE, or GDS data set

This is an input parameter of type CHAR(2) and cannot be null.

dump-option

Specifies whether to use the Db2 standard dump facility to dump the information necessary for problem diagnosis when an SQL error has occurred or when a call to the IBM routine IEFDB476 to get messages about an unsuccessful SVC 99 call failed.

Possible values are:

Y

Generate a dump.

N

Do not generate a dump.

This is an input parameter of type CHAR(1) and cannot be null.

return-code

Provides the return code from the stored procedure. Possible values are:

0

The call completed successfully.

12

The call did not complete successfully. The *message* output parameter contains messages describing the error.

This is an output parameter of type INTEGER.

message

Contains messages describing the error encountered by the stored procedure. If no error occurred, then no message is returned.

The first messages in this area are generated by the stored procedure. Messages that are generated by Db2 or by z/OS might follow the first messages.

This is an output parameter of type VARCHAR(1331).

Additional input

In addition to the input parameters, the stored procedure reads records to be written to a file from a created global temporary table. If the data to be written is text data, then the stored procedure reads records from SYSIBM.TEXT_REC_INPUT. If the data is binary data, then the stored procedure reads records from the created global temporary table SYSIBM.BIN_REC_INPUT.

The following table shows the format of the created global temporary table SYSIBM.TEXT_REC_INPUT containing text records to be saved:

Table 129. Additional input for text data for the ADMIN_DS_WRITE stored procedure

Column name	Data type	Contents
ROWNUM	INTEGER	Sequence number of the table row, from 1 to <i>n</i> .
TEXT_REC	CHAR(80)	Text record to be saved.

The following table shows the format of the created global temporary table SYSIBM.BIN_REC_INPUT containing binary records to be saved:

Table 130. Additional input for binary data for the ADMIN_DS_WRITE stored procedure

Column name	Data type	Contents
ROWNUM	INTEGER	Sequence number of the table row, from 1 to <i>n</i> .
BINARY_REC	VARCHAR(80) FOR BIT DATA	Binary record to be saved.

Example

The following C language sample shows how to invoke ADMIN_DS_WRITE:

```
#include <stdio.h>
#include <stdlib.h>
#include <string.h>

/***** DB2 SQL Communication Area *****/
EXEC SQL INCLUDE SQLCA;

int main( int argc, char *argv[] ) /* Argument count and list */
{
  /***** DB2 Host Variables *****/
  EXEC SQL BEGIN DECLARE SECTION;

  /* SYSPROC.ADMIN_DS_WRITE parameters */
  long int  datatype; /* Data type */
  char      dsname[45]; /* Data set name or GDG */
  char      mbrname[9]; /* Library member name,
                        /* generation # (-1, 0, +1),
                        /* or blank
  char      procopt[3]; /* Processing option */
  char      dumpopt[2]; /* Dump option */
  long int  retcd; /* Return code */
  char      errmsg[1332]; /* Error message */
```

```

/* Temporary table SYSIBM.TEXT_REC_INPUT columns */
long int rownum; /* Sequence number of the */
/* table row */
char textrec[81]; /* Text record */
EXEC SQL END DECLARE SECTION;

/*****
/* Create the records to be saved */
/*****
char dsrecord[12][50] = {
  "//IEBCOPY JOB ,CLASS=K,MSGCLASS=H,MSGLEVEL=(1,1)",
  "//STEP010 EXEC PGM=IEBCOPY",
  "//SYSPRINT DD SYSOUT=*",
  "//SYSUT3 DD SPACE=(TRK,(1,1)),UNIT=SYSDA",
  "//SYSUT4 DD SPACE=(TRK,(1,1)),UNIT=SYSDA",
  "/*",
  "//DDI1 DD DSN=USER.DEV.LOADLIB1,DISP=SHR",
  "//DD01 DD DSN=USER.DEV.LOADLIB2,DISP=SHR",
  "//SYSIN DD *",
  " COPY OUTDD=DD01,INDD=DDI1",
  "/*",
  "/*"
};
int i = 0; /* Loop counter */

/*****
/* Assign the values to input parameters to create a new */
/* partitioned data set and member */
/*****
datatype = 1;
strcpy(dsname, "USER.DATASET.PDS");
strcpy(mbrname, "MEMBER01");
strcpy(procopt, "ND");
strcpy(dumpopt, "N");

/*****
/* Clear temporary table SYSIBM.TEXT_REC_INPUT */
/*****
EXEC SQL DELETE FROM SYSIBM.TEXT_REC_INPUT;

/*****
/* Insert the records to be saved in the new library member */
/* into the temporary table SYSIBM.TEXT_REC_INPUT */
/*****
for (i = 0; i < 12; i++)
{
  rownum = i+1;
  strcpy(textrec, dsrecord[i]);
  EXEC SQL INSERT INTO SYSIBM.TEXT_REC_INPUT
    ( ROWNUM, TEXT_REC )
    VALUES (:rownum, :textrec);
};

/*****
/* Call stored procedure SYSPROC.ADMIN_DS_WRITE */
/*****
EXEC SQL CALL SYSPROC.ADMIN_DS_WRITE
  (:datatype, :dsname, :mbrname, :procopt,
   :dumpopt, :retcd, :errmsg );

return(retcd);
}

```

Output

This stored procedure returns the following output parameters, which are described in “[Option descriptions](#)” on page 747:

- *return-code*
- *message*



ADMIN_EXPLAIN_MAINT stored procedure

You can use the ADMIN_EXPLAIN_MAINT stored procedure to create EXPLAIN tables, upgrade the tables to the format for the current Db2 version, and complete other administrative tasks.

GUI

For more detailed information about administrative tasks that you can complete for EXPLAIN tables by using the ADMIN_EXPLAIN_MAINT stored procedure, see the description of the *action* input parameter.

Important: The ADMIN_EXPLAIN_MAINT stored procedure does not convert EXPLAIN tables that are encoded in EBCDIC to Unicode. However, it does upgrade the format of such tables to the format for the current Db2 version. Starting in DB2 10, SQLCODE -878 is issued for EXPLAIN tables that are encoded in CCSIDs other than Unicode.

Environment

The ADMIN_EXPLAIN_MAINT stored procedure must run in a WLM-established stored procedure address space.

Authorization

To execute the CALL statement, the owner of the package or plan that contains the CALL statement must have one or more of the following privileges on each package that the stored procedure uses:

- EXECUTE privilege on the stored procedure package
- Ownership of the package
- PACKADM authority for the package collection
- SYSADM authority

The stored procedure executes the SET CURRENT SQLID statement to change the value of CURRENT SQLID to the value that is specified by the *authid* input parameter. The value of CURRENT SQLID is the authorization ID for dynamic SQL statements.

Syntax

The following syntax diagram shows the SQL CALL statement for invoking this stored procedure:

```

→ CALL — ADMIN_EXPLAIN_MAINT — ( mode , action , →
      NULL NULL
  manage-alias , table-set , authid , schema-name , →
      NULL NULL
  schema-alias , database-name , stogroup-database , →
      NULL NULL NULL
  stogroup-index , 4k-bufferpool , 8k-bufferpool , →
      NULL NULL NULL
  16k-bufferpool , 32k-bufferpool , index-bufferpool , →
      NULL NULL NULL
  bp-4kb-lob , bp-8kb-lob , bp-16kb-lob , →
      NULL NULL NULL
  bp-32kb-lob , return-code , message ) →
      NULL

```

Option descriptions

mode

Specifies the processing mode. This input parameter accepts the following values:

RUN

Alter and create EXPLAIN tables for the specified SCHEMA.

PREVIEW

No changes are processed.

The data type of this input parameter is VARCHAR(8). If this option is not specified, the default value is RUN.

action

Specifies the action that is completed for the EXPLAIN tables in the specified schema. This input parameter accepts the following values:

STANDARDIZE

Upgrade all existing EXPLAIN tables to the format for the current Db2 version.

STANDARDIZE_AND_CREATE

Upgrade all existing EXPLAIN tables to the format for the current Db2 version, and create any missing tables of those that are specified by the *table-set* input parameter.

CREATE

Create a new set of EXPLAIN tables in the specified schema. Only tables that are specified by the *table-set* input parameter are created.

CREATE_ALIAS

Create a new set of aliases only. The new aliases are qualified by the value that is specified for the *schema-alias* input parameter.

DROP

Drop all existing EXPLAIN tables and the associated table space.

DROP_AND_CREATE

Drop all existing EXPLAIN tables, and the associated table spaces, and create a replacement set of the tables that are specified by the *table-set* input parameter.

The data type of this input parameter is VARCHAR(30). If this option is not specified, the default value is STANDARDIZE.

manage-alias

Specifies whether to create aliases for EXPLAIN tables. This input parameter accepts the following values:

YES

The stored procedure creates aliases so that all EXPLAIN tables in the specified schema have aliases that correspond to the existing PLAN_TABLE aliases.

NO

Aliases are not created.

The data type of this input parameter is VARCHAR(3). If this option is not specified, the default value is NO.

table-set

Specifies the list of EXPLAIN tables to be created.

If the *action* value is CREATE, the tables that are specified must not already exist. This input parameter accepts the following values:

'table-name-1, table-name-2, ..., table-name-n'

Specifies an explicit list of tables to create.

ALL

All EXPLAIN tables that are created by the DSNTESC and DSNTESH sample jobs.

ACCEL

The following tables only:

- PLAN_TABLE
- DSN_STATEMNT_TABLE
- DSN_STATEMENT_CACHE_TABLE
- DSN_QUERYINFO_TABLE

DIAGNOSTICS

The following tables only:

- PLAN_TABLE
- DSN_STATEMNT_TABLE
- DSN_DETCOST_TABLE
- DSN_PREDICAT_TABLE
- DSN_FILTER_TABLE
- DSN_COLDIST_TABLE
- DSN_KEYTGTDIST_TABLE
- DSN_QUERYINFO_TABLE

ALL_EXCEPT(table-name-1, table-name-2, ..., table-name-n)

All tables that are created by the DSNTESC and DSNTESH sample jobs except for the tables that are specified in the list.

This value is applicable only if *action* is one of the following values:

- STANDARDIZE_AND_CREATE
- CREATE
- DROP_AND_CREATE

The data type of this input parameter is VARCHAR(1000). If this option is not specified, the following EXPLAIN tables are created by default:

- PLAN_TABLE

- DSN_STATEMNT_TABLE
- DSN_STATEMENT_CACHE_TABLE

authid

The CURRENT SQLID setting. If this option is not specified, the value of the CURRENT SQLID special register is used. The data type of this required input parameter is VARCHAR(128).

schema-name

Specifies the schema name that qualifies the EXPLAIN tables. If this option is not specified, the value of the CURRENT SCHEMA special register is used. The data type of this required input parameter is VARCHAR(128).

schema-alias

Specifies the schema name that qualifies aliases that are created when the *action* value is CREATE_ALIAS. The data type of this input parameter is VARCHAR(128). This input parameter is required when the *action* value is CREATE_ALIAS.

database-name

Specifies the database that contains the new EXPLAIN tables. The stored procedure creates the database if it does not exist. The data type of this input parameter is VARCHAR(8). If this option is not specified, the stored procedure omits the database and table space names in the CREATE TABLE statements for the EXPLAIN tables.

stogroup-database

Specifies the storage group for the database that contains the new EXPLAIN tables. The data type of this input parameter is VARCHAR(128). If this option is not specified, the stored procedure omits the STOGROUP keyword from the CREATE DATABASE statement, if the database does not already exist.

stogroup-index

Specifies the storage group for the indexes for the new EXPLAIN tables. The data type of this input parameter is VARCHAR(128). If this option is not specified, the stored procedure omits the USING STOGROUP keyword from the CREATE INDEX statement.

4k-bufferpool

Specifies the name of the 4-KB page buffer pool that is assigned to new table spaces. The data type of this input parameter is VARCHAR(8). If this option is not specified, the stored procedure omits the table space name in the CREATE TABLE statements for the EXPLAIN tables.

8k-bufferpool

Specifies the name of the 8 KB page buffer pool that is assigned to new table spaces. The data type of this input parameter is VARCHAR(8). If this option is not specified, the stored procedure omits the table space name in the CREATE TABLE statements for the EXPLAIN tables.

16k-bufferpool

Specifies the name of the 16 KB page buffer pool that is assigned to new table spaces. The data type of this input parameter is VARCHAR(8). If this option is not specified, the stored procedure omits the table space name in the CREATE TABLE statements for the EXPLAIN tables.

32k-bufferpool

Specifies the name of the 32 KB page buffer pool that is assigned to new table spaces. The data type of this input parameter is VARCHAR(8). If this option is not specified, the stored procedure omits the table space name in the CREATE TABLE statements for the EXPLAIN tables.

index-bufferpool

Specifies the name of the buffer pool for the indexes for the new EXPLAIN tables. The data type of this input parameter is VARCHAR(8). If this option is not specified, the stored procedure omits the BUFFERPOOL keyword from the CREATE INDEX statement.

bp-4kb-lob

Specifies the name of the 4-KB page buffer pool that is assigned to new LOB tables spaces for the new auxiliary tables of the new EXPLAIN tables. The data type of this input parameter is VARCHAR(8). If this option is not specified, the stored procedure omits the BUFFERPOOL keyword from the CREATE LOB TABLESPACE statement.

bp-8kb-lob

Specifies the name of the 8-KB page buffer pool that is assigned to new LOB tables spaces for the new auxiliary tables of the new EXPLAIN tables. The data type of this input parameter is VARCHAR(8). If this option is not specified, the stored procedure omits the BUFFERPOOL keyword from the CREATE LOB TABLESPACE statement.

bp-16kb-lob

Specifies the name of the 16-KB page buffer pool that is assigned to new LOB tables spaces for the new auxiliary tables of the new EXPLAIN tables. The data type of this input parameter is VARCHAR(8). If this option is not specified, the stored procedure omits the BUFFERPOOL keyword from the CREATE LOB TABLESPACE statement.

bp-32kb-lob

Specifies the name of the 32-KB page buffer pool that is assigned to new LOB tables spaces for the new auxiliary tables of the new EXPLAIN tables. The data type of this input parameter is VARCHAR(8). If this option is not specified, the stored procedure omits the BUFFERPOOL keyword from the CREATE LOB TABLESPACE statement.

return-code

An output parameter that contains the return code from the stored procedure. It contains one of the following values:

0

The call completed successfully.

4

One or more existing EXPLAIN tables are not in Unicode. The table formats are updated to the format for the current Db2 version. However, the tables are not converted to Unicode.

8

The format of one or more existing EXPLAIN tables that were included in the *table-set* input parameter cannot be updated to the format for the current Db2 version because the existing format does not match any known format, or the tables cannot be altered by an ALTER TABLE statement.

12

The call did not complete successfully. The *message* output parameter contains messages that describe the error.

message

An output parameter that contains messages that describe errors that the stored procedure encountered.

The following C language sample shows how to invoke the ADMIN_EXPLAIN_MAINT stored procedure:

```
#include <stdio.h>
#include <stdlib.h>
#include <string.h>
/***** DB2 SQL Communication Area *****/
EXEC SQL INCLUDE SQLCA;
int main( int argc, char *argv[] ) /* Argument count and list */
{
/***** DB2 Host Variables *****/
EXEC SQL BEGIN DECLARE SECTION;
/* SYSPROC.ADMIN_EXPLAIN_MAINT parameters */
char pmode[9]; /* Processing mode */
char paction[31]; /* Action */
char pmanagealias[4]; /* Manage alias */
char ptableset[1001]; /* EXPLAIN tables to be created */
char pauthid[129]; /* CURRENT SQLID setting */
char pschema[129]; /* EXPLAIN tables qualifier */
char pschemaalias[129]; /* EXPLAIN tables aliases qual */
char pdatabase[9]; /* Database of EXPLAIN tables */
char pstogroupdb[129]; /* Storage group of database */
char pstogroupix[129]; /* Storage group of EXPLAIN
/* tables indexes */
char p4Kbp[9]; /* 4 KB page buffer pool for
/* table space of EXPLAIN table */
char p8Kbp[9]; /* 8 KB page buffer pool for
/* table space of EXPLAIN table */
char p16Kbp[9]; /* 16 KB page buffer pool for */
```

```

char      p32Kbp[9];          /* table space of EXPLAIN table */
char      pixbp[9];          /* 32 KB page buffer pool for */
char      p4Klobbp[9];       /* table space of EXPLAIN table */
char      p8Klobbp[9];       /* Buffer pool for indexes of */
char      p16Klobbp[9];      /* EXPLAIN tables */
char      p32Klobbp[9];      /* 4 KB page buffer pool for */
long int   prc;              /* LOB table space */
char      pmsg[1332];        /* 8 KB page buffer pool for */
short int  ind_pmode;        /* LOB table space */
short int  ind_paction;      /* 16 KB page buffer pool for */
short int  ind_pmanagealias; /* LOB table space */
short int  ind_ptableset;    /* 32 KB page buffer pool for */
short int  ind_pauthid;     /* LOB table space */
short int  ind_pschema;     /* Return code */
short int  ind_pschemaalias; /* Error message */
short int  ind_pdatabase;    /* Indicator variable */
short int  ind_pstogroupdb;  /* Indicator variable */
short int  ind_pstogroupix;  /* Indicator variable */
short int  ind_p4Kbp;        /* Indicator variable */
short int  ind_p8Kbp;        /* Indicator variable */
short int  ind_p16Kbp;       /* Indicator variable */
short int  ind_p32Kbp;       /* Indicator variable */
short int  ind_pixbp;        /* Indicator variable */
short int  ind_p4Klobbp;     /* Indicator variable */
short int  ind_p8Klobbp;     /* Indicator variable */
short int  ind_p16Klobbp;    /* Indicator variable */
short int  ind_p32Klobbp;    /* Indicator variable */
short int  ind_prc;          /* Indicator variable */
short int  ind_pmsg;         /* Indicator variable */
/* Result set locators */
volatile SQL TYPE IS RESULT_SET_LOCATOR *rs_loc1;
volatile SQL TYPE IS RESULT_SET_LOCATOR *rs_loc2;
volatile SQL TYPE IS RESULT_SET_LOCATOR *rs_loc3;
/* SYSIBM.EXPLAIN_MAINT_SUMMARY result set row */
long int   db_created;        /* Num databases created */
long int   ts_created;        /* Num table spaces created */
long int   tb_created;        /* Num EXPLAIN tables created */
long int   aux_created;       /* Num aux tables created */
long int   ix_created;        /* Num indexes created */
long int   alias_created;     /* Num aliases created */
long int   tb_examined;      /* Num EXPLAIN tables examined */
long int   tb_altered;        /* Num databases created for old format */
long int   ts_dropped;        /* Num table spaces dropped */
long int   tb_dropped;        /* Num EXPLAIN tables dropped */
long int   tb_unexpected_format; /* Num EXPLAIN tables with invalid format */
long int   tb_not_standardized; /* Num EXPLAIN tables not upgraded to the current DB2 release format */
long int   tb_not_unicode;    /* Num EXPLAIN tables not in UNICODE */
/* SYSIBM.EXPLAIN_MAINT_SQL result set row */
long int   rownum2;           /* Sequence number of the table row */
char       sql[16000];        /* SQL statement */
/* SYSIBM.EXPLAIN_MAINT_TB_NOT_UPGRADED result set row */
long int   rownum3;           /* Sequence number of the table row */
char       schemaname[129];   /* EXPLAIN table qualifier */
char       tbname[129];       /* EXPLAIN table name */
char       reason[1001];      /* Reason */
EXEC SQL END DECLARE SECTION;

int resultset3 = 0;           /* Result set 3 not returned */
/*****
/* Clear result tables */
/*****
EXEC SQL DELETE FROM SYSIBM.EXPLAIN_MAINT_SUMMARY;
EXEC SQL DELETE FROM SYSIBM.EXPLAIN_MAINT_SQL;
EXEC SQL DELETE FROM SYSIBM.EXPLAIN_MAINT_TB_NOT_UPGRADED;
/*****
/* Set procedure input parameters */
/*****

```



```

strcpy(paction, "STANDARDIZE_AND_CREATE");
strcpy(ptableset,
      "DSN_PREDICATE_SELECTIVITY, DSN_STAT_FEEDBACK");
strcpy(pauthid, "USER001");
strcpy(pschem, "USER002");
ind_pmode = -1;
ind_paction = 0;
ind_pmanagealias = -1;
ind_ptableset = 0;
ind_pauthid = 0;
ind_pschem = 0;
ind_pschemalias = -1;
ind_pdatabase = -1;
ind_pstogroupdb = -1;
ind_pstogrouppix = -1;
ind_p4Kbp = -1;
ind_p8Kbp = -1;
ind_p16Kbp = -1;
ind_p32Kbp = -1;
ind_pixbp = -1;
ind_p4Klobbp = -1;
ind_p8Klobbp = -1;
ind_p16Klobbp = -1;
ind_p32Klobbp = -1;
ind_prc = -1;
ind_pmsg = -1;
/*****
/* Call stored procedure SYSPROC.ADMIN_EXPLAIN_MAINT
/*****
EXEC SQL CALL SYSPROC.ADMIN_EXPLAIN_MAINT (
      :pmode:ind_pmode,
      :paction:ind_paction,
      :pmanagealias:ind_pmanagealias,
      :ptableset:ind_ptableset,
      :pauthid:ind_pauthid,
      :pschem:ind_pschem,
      :pschemalias:ind_pschemalias,
      :pdatabase:ind_pdatabase,
      :pstogroupdb:ind_pstogroupdb,
      :pstogrouppix:ind_pstogrouppix,
      :p4Kbp:ind_p4Kbp,
      :p8Kbp:ind_p8Kbp,
      :p16Kbp:ind_p16Kbp,
      :p32Kbp:ind_p32Kbp,
      :pixbp:ind_pixbp,
      :p4Klobbp:ind_p4Klobbp,
      :p8Klobbp:ind_p8Klobbp,
      :p16Klobbp:ind_p16Klobbp,
      :p32Klobbp:ind_p32Klobbp,
      :prc:ind_prc,
      :pmsg:ind_pmsg);
/*****
/* Retrieve result sets when the SQLCODE from the call is +446,
/* which indicates that result sets were returned
/*****
if (SQLCODE == +466) /* Result sets were returned
{
  /* Establish a link between a result set and its locator
  EXEC SQL ASSOCIATE LOCATORS (:rs_loc1, :rs_loc2, :rs_loc3)
  WITH PROCEDURE SYSPROC.ADMIN_EXPLAIN_MAINT;
  /* Associate a cursor with each result set
  EXEC SQL ALLOCATE C1 CURSOR FOR RESULT SET :rs_loc1;
  EXEC SQL ALLOCATE C2 CURSOR FOR RESULT SET :rs_loc2;
  EXEC SQL ALLOCATE C3 CURSOR FOR RESULT SET :rs_loc3;
  if (SQLCODE == 0) /* Result set 3 is returned
  resultset3 = 1;
  /* Perform fetch using C1 to retrieve the first result set
  EXEC SQL FETCH C1 INTO :db_created, :ts_created,
  :tb_created, :aux_created,
  :ix_created, :alias_created,
  :tb_examined, :tb_altered,
  :ts_dropped, :tb_dropped,
  :tb_unexpected_format,
  :tb_not_standardized,
  :tb_not_unicode;
  /* Perform fetches using C2 to retrieve all rows from the
  /* second result set
  EXEC SQL FETCH C2 INTO :rownum2, :sql;
  while (SQLCODE == 0)
  {
    EXEC SQL FETCH C2 INTO :rownum2, :sql;
  }
}

```

```

/* Perform fetches using C3 to retrieve all rows from the          */
/* third result set                                              */
if (resultset3 == 1)
{
  EXEC SQL FETCH C3 INTO :rownum3, :schemaname, :tbname,
                        :reason;
  while (SQLCODE == 0)
  {
    EXEC SQL FETCH C3 INTO :rownum3, :schemaname, :tbname,
                          :reason;
  }
}
}
return;
}

```

Output

The ADMIN_EXPLAIN_MAINT stored procedure creates as many as three result sets that are returned in the following global temporary tables:

SYSIBM.EXPLAIN_MAINT_SUMMARY

The summary of the actions completed by the stored procedure if the value of the *mode* input parameter is RUN. If the value of the *mode* input parameter is PREVIEW, this result set summarizes the actions, but the actions are not completed. The values of the various *type_CREATED*, *type_ALTERED*, *type_DROPPED* columns summarize the numbers of corresponding statements for each action in the SQL column of SYSIBM.EXPLAIN_MAINT_SQL result set.

<i>Table 131. Format of the SYSIBM.EXPLAIN_MAINT_SUMMARY result set</i>		
Column name	Data Type	Description
DB_CREATED	INTEGER NOT NULL	The number of databases that are created.
TS_CREATED	INTEGER NOT NULL	The number of table spaces that are created.
TB_CREATED	INTEGER NOT NULL	The number of EXPLAIN tables that are created.
AUX_CREATED	INTEGER NOT NULL	The number of auxiliary tables that are created.
IX_CREATED	INTEGER NOT NULL	The number of indexes that are created.
ALIAS_CREATED	INTEGER NOT NULL	The number of aliases that are created.
TB_EXAMINED	INTEGER NOT NULL	The number of EXPLAIN tables that were examined for formats older than the format for the current Db2 version.
TB_ALTERED	INTEGER NOT NULL	The number of tables that are altered to use the format for the current Db2 version.
TS_DROPPED	INTEGER NOT NULL	The number of table spaces that were dropped.
TB_DROPPED	INTEGER NOT NULL	The number of EXPLAIN tables that are dropped.

<i>Table 131. Format of the SYSIBM.EXPLAIN_MAINT_SUMMARY result set (continued)</i>		
Column name	Data Type	Description
TB_UNEXPCEDTED_FORMAT	INTEGER NOT NULL	The number of EXPLAIN tables that do not match any known valid format.
TB_NOT_STANDARDIZED	INTEGER NOT NULL	The number of EXPLAIN tables that cannot be converted to the format for the current Db2 version.
TB_NOT_UNICODE	INTEGER NOT NULL	The number of existing EXPLAIN tables that are encoded in a CCSID other than Unicode. Such tables are upgraded to the format for the current Db2 version, but the CCSID is not changed to Unicode.

SYSIBM.EXPLAIN_MAINT_SQL

A list of the SQL statements that the stored procedure issues if the value of the *mode* input parameter is RUN. If the value of the *mode* input parameter is PREVIEW, this result set summarizes the actions, but the statements are not issued.

<i>Table 132. Format of the SYSIBM.EXPLAIN_MAINT_SQL result set</i>		
Column name	Data Type	Description
ROWNUM	INTEGER NOT NULL	The sequence number of the table row, 1 - <i>n</i> .
SQL	VARCHAR(16000) NOT NULL	The text of an SQL statement that is issued by the stored procedure to create, alter, or drop EXPLAIN tables and related objects.

Table space names: Table spaces that the ADMIN_EXPLAIN_MAINT stored procedure creates for EXPLAIN tables and related auxiliary tables have names that are based on a four-letter abbreviation of the name of the associated table, followed by a four-digit number that ensures the uniqueness name. The four-letter abbreviations do not follow a consistent pattern in relation to the various table names. For example, PLANnnnn is used for PLAN_TABLE, STMTnnnn is for DSN_STATEMNT_TABLE, and SFEDnnnn is used for DSN_STAT_FEEDBACK table.

You can find the names of the table spaces that the stored procedure creates in the SYSIBM.EXPLAIN_MAINT_SQL result set.

SYSIBM.EXPLAIN_MAINT_TB_NOT_UPGRADED

This result set is returned only when the value of the *action* input parameter is STANDARDIZE or STANDARDIZE_AND_CREATE and at least one of the following conditions is true. The result set contains one row for each of the following occurrences:

- The table is created with a CSSID other than Unicode. Such tables might be upgraded to the format for the current Db2 version. However, the CCSID is not changed to Unicode.
- The format of the EXPLAIN table does not match any known format. Such tables are not upgraded.
- ALTER TABLE statements cannot complete changes that are required to upgrade a table to the format for the current Db2 version. Such tables are not upgraded.

<i>Table 133. Format of the SYSIBM.EXPLAIN_TMAIN_TB_NOT_UPGRADED result set</i>		
Column name	Data Type	Description
ROWNUM	INTEGER NOT NULL	The sequence number of the table row, 1 - n.
SCHEMA	VARCHAR(128) NOT NULL	The schema of an EXPLAIN table that cannot be converted to the format for the current version of Db2.
TBNAME	VARCHAR(128) NOT NULL	The name of an EXPLAIN table that cannot be converted to the format for the current version of Db2.
REASON	VARCHAR(1000) NOT NULL	A description of the reason why the table cannot be converted to the format for the current version of Db2.

GUPI

Related concepts

[Interpreting data access by using EXPLAIN \(Db2 Performance\)](#)

Related tasks

[Creating EXPLAIN tables \(Db2 Performance\)](#)

[Migration step 25: Convert EXPLAIN tables to the current format \(Db2 Installation and Migration\)](#)

Related reference

[EXPLAIN tables \(Db2 Performance\)](#)

[EXPLAIN statement](#)

ADMIN_INFO_HOST stored procedure

The SYSPROC.ADMIN_INFO_HOST stored procedure returns the hostname of a connected Db2 subsystem or the hostname of every member of a data sharing group.

Environment

GUPI

ADMIN_INFO_HOST runs in a WLM-established stored procedures address space.

Authorization

To execute the CALL statement, the owner of the package or plan that contains the CALL statement must have one or more of the following privileges on each package that the stored procedure uses:

- The EXECUTE privilege on the package for DSNADMIH
- Ownership of the package
- PACKADM authority for the package collection
- SYSADM authority

The ADMIN_INFO_HOST stored procedure internally calls the ADMIN_COMMAND_DB2 stored procedure to execute the following Db2 commands:

- -DISPLAY DDF
- -DISPLAY GROUP

The owner of the package or plan that contains the CALL ADMIN_INFO_HOST statement must also have the authorization required to execute the stored procedure ADMIN_COMMAND_DB2 and the specified Db2 commands. To determine the privilege or authority required to issue a Db2 command, see [About Db2 and related commands \(Db2 Commands\)](#).

Syntax

The following syntax diagram shows the SQL CALL statement for invoking this stored procedure:

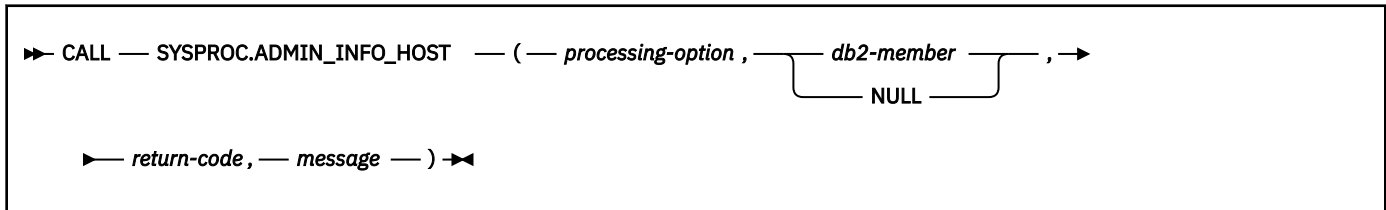

Option descriptions

processing-option

Specifies processing option. Possible values are:

1

Return the hostname of the connected Db2 subsystem or the hostname of a specified Db2 data sharing group member.

For a data sharing group member, you must specify *db2-member*.

2

Return the hostname of every Db2 member of the same data sharing group.

This is an input parameter of type INTEGER and cannot be null.

DB2-member

Specifies the Db2 data sharing group member name.

This parameter must be null if *processing-option* is 2.

This is an input parameter of type CHAR(8).

return-code

Provides the return code from the stored procedure. Possible values are:

0

The call completed successfully.

4

Unable to list the hostname of the connected Db2 subsystem or of every Db2 member of the same data sharing group due to one of the following reasons:

- The IPADDR field returned when the -DISPLAY DDF command is executed on the connected Db2 subsystem or Db2 member contains the value -NONE
- One of the Db2 members is down

12

The call did not complete successfully. The *message* output parameter contains messages describing the error.

This is an output parameter of type INTEGER.

message

Contains messages describing the error encountered by the stored procedure. If no error occurred, then no message is returned.

The first messages in this area are generated by the stored procedure. Messages that are generated by Db2 might follow the first messages.

This is an output parameter of type VARCHAR(1331).

Example

The following C language sample shows how to invoke ADMIN_INFO_HOST:

```
#include <stdio.h>
#include <stdlib.h>
#include <string.h>

/***** DB2 SQL Communication Area *****/
EXEC SQL INCLUDE SQLCA;

int main( int argc, char *argv[] ) /* Argument count and list */
{
  /***** DB2 Host Variables *****/
  EXEC SQL BEGIN DECLARE SECTION;

  /* SYSPROC.ADMIN_INFO_HOST parameters */
  long int   procopt;          /* Processing option */
  short int  ind_procopt;     /* Indicator variable */
  char       db2mbr[9];       /* Data sharing group member
                               /* name */
  short int  ind_db2mbr;      /* Indicator variable */
  long int   retcd;           /* Return code */
  short int  ind_retcd;       /* Indicator variable */
  char       errmsg[1332];    /* Error message */
  short int  ind_errmsg;      /* Indicator variable */

  /* Result set locators */
  volatile SQL TYPE IS RESULT_SET_LOCATOR *rs_loc1;

  /* Result set row */
  long int   rownum;          /* Sequence number of the
                               /* table row */
  char       db2member[9];    /* DB2 data sharing group
                               /* member name */
  char       hostname[256];   /* Host name of the connected
                               /* DB2 subsystem or DB2
                               /* member name */

  EXEC SQL END DECLARE SECTION;

  /***** Assign values to input parameters to find the hostname of
  /* the connected DB2 subsystem */
  /* Set the indicator variables to 0 for non-null input parameters */
  /* Set the indicator variables to -1 for null input parameters */
  /***** */
  procopt = 1;
  ind_procopt = 0;
  ind_db2mbr = -1;

  /***** Call stored procedure SYSPROC.ADMIN_INFO_HOST */
  EXEC SQL CALL SYSPROC.ADMIN_INFO_HOST
              (:procopt :ind_procopt,
               :db2mbr  :ind_db2mbr,
               :retcd   :ind_retcd,
               :errmsg   :ind_errmsg);

  /***** Retrieve result set when the SQLCODE from the call is +446,
  /* which indicates that result sets were returned */
  /***** */
  if (SQLCODE == +446) /* Result sets were returned */
  {
    /* Establish a link between the result set and its locator */
    EXEC SQL ASSOCIATE LOCATORS (:rs_loc1)
            WITH PROCEDURE SYSPROC.ADMIN_INFO_HOST;

    /* Associate a cursor with the result set */
    EXEC SQL ALLOCATE C1 CURSOR FOR RESULT SET :rs_loc1;

    /* Use C1 to fetch the only row from the result set */
    EXEC SQL FETCH C1 INTO :rownum, :db2mbr, :hostname;

    EXEC SQL CLOSE C1;
  }
}
```

```

return(retcd);
}

```

Output

This stored procedure returns the following output parameters, which are described in “[Option descriptions](#)” on page 761:

- *return-code*
- *message*

In addition to the preceding output, the stored procedure returns one result set that contains the hostnames.

The following table shows the format of the result set returned in the created global temporary table SYSIBM.SYSTEM_HOSTNAME:

Table 134. Result set row for ADMIN_INFO_HOST result set

Column name	Data type	Contents
ROWNUM	INTEGER	Sequence number of the table row, from 1 to <i>n</i> .
DB2_MEMBER	CHAR(8)	Db2 data sharing group member name.
HOSTNAME	VARCHAR(255)	Host name of the connected Db2 subsystem if the <i>processing-option</i> input parameter is 1 and the <i>db2-member</i> input parameter is null. Otherwise, the hostname of the Db2 member specified in the DB2_MEMBER column.



Related reference

- DISPLAY DDF command (Db2) (Db2 Commands)
- DISPLAY GROUP command (Db2) (Db2 Commands)

ADMIN_INFO_IFCID stored procedure

The ADMIN_INFO_IFCID stored procedure returns Db2 instrumentation facility interface (IFI) information.

Environment

ADMIN_INFO_IFCID must run in a WLM-established stored procedure address space.

Authorization

To execute the CALL statement, the owner of the package or plan that contains the CALL statement must have one or more of the following privileges on each package that the stored procedure uses:

- The EXECUTE privilege on the package for DSNADMIF
- Ownership of the package
- PACKADM authority for the package collection
- SYSADM authority

The user who calls this stored procedure must have MONITOR1 privilege.

Syntax

The following syntax diagram shows the SQL CALL statement for invoking this stored procedure:

```
CALL — SYSPROC.ADMIN_INFO_IFCID — ( — ifcid, — Db2-member, — return-code, — message, →  
→ ) →
```

Option descriptions

ifcid

Specifies the Db2 instrumentation facility component ID (IFCID). Valid values are: 1, 2, 225.

This is an input parameter of type INTEGER and cannot be null.

db2-member

Specifies the name of the single data sharing group member that executes the IFI request.

This is an input parameter of type VARCHAR(8) and must be null.

return-code

Provides the return code from the stored procedure. Possible values are:

0

The call completed successfully.

12

The call did not complete successfully. The MSG output parameter contains messages that describe the error that is encountered by the stored procedure.

This is an output parameter of type INTEGER.

message

Contains messages that describe the error that was encountered by the stored procedure. If an error did not occur, a message is not returned.

This is an output parameter of type VARCHAR(1331).

Output

This stored procedure returns the following output parameters, which are described in [“Option descriptions”](#) on page 764:

- *return-code*
- *message*

In addition to the preceding output, the stored procedure returns one result set that contains the IFI record associated with the IFCID specified. The following table shows the format of the result set that is returned in the created global temporary table SYSIBM.IFIREC:

Table 135.

Column name	Data type	Contents
ROWNUM	INTEGER NOT NULL	Sequence number of the table row, from 1 to <i>n</i>

Table 135. (continued)

Column name	Data type	Contents
IFIREC	VARCHAR(32000) FOR BIT DATA NOT NULL	VARCHAR(32000) FOR BIT DATA NOT NULL. If an IFCID record exceeds 32,000 characters it is split up and inserted into this table with the sequence starting at 1, and then incremented with every insert.

Example

The following example program calls the ADMIN_INFO_IFCID stored procedure.

```

#include <stdio.h>
#include <stdlib.h>
#include <string.h>

/***** DB2 SQL Communication Area *****/
EXEC SQL INCLUDE SQLCA;

int main( int argc, char *argv[] ) /* Argument count and list */
{
/***** DB2 Host Variables *****/
EXEC SQL BEGIN DECLARE SECTION;

/* SYSPROC.ADMIN_INFO_IFCID parameters */
long int ifcid; /* IFCID */
short int ind_ifcid; /* Indicator variable */
char db2_member[9]; /* Data sharing group member */
short int ind_db2_member; /* Indicator variable */
long int retcd; /* Return code */
short int ind_retcd; /* Indicator variable */
char errmsg[1332]; /* Error message */
short int ind_errmsg; /* Indicator variable */
/* Result set locators */
volatile SQL TYPE IS RESULT_SET_LOCATOR *rs_loc1;
/* Result set row */
long int rownum; /* Sequence number of the
/* table row (1,...,n) */

struct {
short len;
char text[32001];
} ifirec; /* IFI record
*/

EXEC SQL END DECLARE SECTION;

/***** Initializatisation */
ifcid = 1;
retcd = 0;
errmsg[0] = '\0';
ind_ifcid = 0;
ind_db2_member = -1;
ind_retcd = -1;
ind_errmsg = -1;
rownum = 0;
ifirec.len = 0;
ifirec.text[0] = '\0';
/***** Call stored procedure SYSPROC.ADMIN_INFO_IFCID */
EXEC SQL CALL SYSPROC.ADMIN_INFO_IFCID
(:ifcid :ind_ifcid,
:db2_member :ind_db2_member,
:retcd :ind_retcd,
:errmsg :ind_errmsg);
/***** Retrieve result set when the SQLCODE from the call is +446, */

```

```

/* which indicates that result sets were returned */
/*****
if (SQLCODE == +466) /* Result sets were returned */
{
  /* Establish a link between the result set and its locator */
  EXEC SQL ASSOCIATE LOCATORS (:rs_loc1)
    WITH PROCEDURE SYSPROC.ADMIN_INFO_IFCID;
  /* Associate a cursor with the result set */
  EXEC SQL ALLOCATE C1 CURSOR FOR RESULT SET :rs_loc1;
  /* Perform fetches using C1 to retrieve all rows from the
  /* result set */
  EXEC SQL FETCH C1
    INTO :rownum, :ifirec;
  while(SQLCODE==0)
  {
    EXEC SQL FETCH C1
      INTO :rownum, :ifirec;
  }
  EXEC SQL CLOSE C1;
}
return(retcd);
}

```

Related concepts

[Programming for the instrumentation facility interface \(IFI\) \(Db2 Performance\)](#)

Related reference

[Instrumentation facility interface \(IFI\) records \(Db2 Performance\)](#)

ADMIN_INFO_SMS stored procedure

The ADMIN_INFO_SMS stored procedure returns space information about copy pools and their storage groups and volumes.

Environment

GUPI

The load module for this stored procedure, DSNADMIV, must reside in an APF-authorized library. ADMIN_INFO_SMS runs in a WLM-established stored procedures address space. All libraries in this WLM procedure STEPLIB DD concatenation must be APF-authorized.

Authorization

To execute the CALL statement, the owner of the package or plan that contains the CALL statement must have one or more of the following privileges on each package that the stored procedure uses:

- The EXECUTE privilege on the package for DSNADMIV
- Ownership of the package
- PACKADM authority for the package collection
- SYSADM authority

Syntax

The following syntax diagram shows the SQL CALL statement for invoking this stored procedure:

```

▶ CALL — SYSPROC.ADMIN_INFO_SMS — ( — return-code , — message — ) ▶

```

Option descriptions

return-code

Provides the return code from the stored procedure. The following values are possible:

0

The stored procedure completed successfully.

4

The stored procedure could not return the volume space statistics for all of the requested objects. The *message* output parameter contains messages that describe the warnings.

This return code is issued when one or more objects that are returned in the result set contains one of the following messages in the ERRMSG column:

- OBJECT NOT FOUND: Indicates that the copy pool, storage group, or volume that is specified in the input table is not found, as reported by the SMS construct access services.
- NO VOLUMES ASSOCIATED WITH STORAGE GROUP: Indicates that the storage group that is specified in the input table does not have any volumes, as reported by the SMS construct access services.
- NO STORAGE GROUPS ASSOCIATED WITH COPY POOL: Indicates that the copy pool that is specified in the input table does not have any storage groups, as reported by the SMS construct access services.
- DSNAD661I DSNADMIV THE MACRO LSPACE FAILED WITH RETURN CODE=*nn*

12

The call did not complete successfully. The *message* output parameter contains messages that describe a parameter error, an SQL error, or an internal error that was encountered by the stored procedure.

This is an output parameter of type INTEGER.

message

Contains messages that describe a parameter error, an SQL error, or an internal error that was encountered by the stored procedure. If an error did not occur, a message is not returned.

This is an output parameter of type VARCHAR(1331).

Input

This stored procedure reads from the created global temporary table SYSIBM.SMS_OBJECTS to determine which objects' space statistics to return.

The following table shows the format of the SYSIBM.SMS_OBJECTS input table.

Table 136. Input row for the ADMIN_INFO_SMS stored procedure

Column name	Data type	Contents
OBJECTID	INTEGER NOT NULL	A unique positive identifier for the object that a set of volume space statistics is associated with.
OBJECTTYPE	CHAR(1) NOT NULL	Valid values are: <ul style="list-style-type: none">• 'C': Copy pool• 'S': Storage group• 'V': Volume

Table 136. Input row for the ADMIN_INFO_SMS stored procedure (continued)

Column name	Data type	Contents
OBJECTNAME	VARCHAR(30) NOT NULL	Valid values are: <ul style="list-style-type: none"> • Copy pool name, if OBJECTTYPE is 'C'. Returns all of the volumes that are associated with each storage group in this copy pool, along with the corresponding volume space statistics. • Storage group name, if OBJECTTYPE is 'S'. Returns all of the volumes that are associated with this storage group, along with the corresponding volume space statistics. • Volume name, if OBJECTTYPE is 'V'. Returns the volume space statistics for this volume.

Output

This stored procedure returns the following output parameters, which are described in “[Option descriptions](#)” on page 766:

- *return-code*
- *message*

In addition to the preceding output, the stored procedure returns one result set that contains the volume space statistics.

The following table shows the format of the result set that is returned in the created global temporary table SYSIBM.SMS_INFO. The result set rows are returned in ascending order by ROWNUM and OBJECTID.

Table 137. Result set row for ADMIN_INFO_SMS result set

Column name	Data type	Contents
ROWNUM	INTEGER NOT NULL	Sequence number of the table row, from 1 to <i>n</i> .
OBJECTID	INTEGER NOT NULL	A unique positive identifier for the object that a set of volume space statistics is associated with. This ID is used to reference the object in the input table SYSIBM.SMS_OBJECTS.
COPYPOOL	VARCHAR(30)	A copy pool. This value is NULL if a storage group or volume is specified. For example, if the corresponding OBJECTTYPE in the SYSIBM.SMS_OBJECTS table is 'S' or 'V'.
STORAGEGROUP	VARCHAR(30)	A copy pool storage group. This value is NULL if no storage groups are associated with the specified copy pool, or if a volume is specified. For example, if the corresponding OBJECTTYPE in the SYSIBM.SMS_OBJECTS table is 'V'.

Table 137. Result set row for ADMIN_INFO_SMS result set (continued)

Column name	Data type	Contents
VOLUME	VARCHAR(6)	<p>A volume in a copy pool storage group. This value is NULL in the following cases:</p> <ul style="list-style-type: none"> • If no volumes are associated with the specified storage group • If no volumes are associated with a storage group that is associated with the specified copy pool • If no storage groups are associated with the specified copy pool
TOTALCAPACITY	INTEGER NOT NULL	<p>Total capacity of a volume, in megabytes. The value is -1 if the VOLUME column is NULL.</p>
FREESPACE	INTEGER NOT NULL	<p>The total amount of free space in a volume, in megabytes. The value is -1 if the VOLUME column is NULL.</p> <p>For a Db2 volume, this is the amount of space in the copy pool that has not been allocated by Db2 yet. Therefore, disk space that has been allocated by Db2, but is currently not used (like data records that were deleted) would not fall into this category.</p>
LARGESTFREEEXT	INTEGER NOT NULL	<p>Largest free extent in a volume, in megabytes. The value is -1 if the VOLUME column is NULL.</p>
ERRMSG	VARCHAR(256)	<p>Possible values are:</p> <ul style="list-style-type: none"> • NULL • OBJECT NOT FOUND: Indicates that the copy pool, storage group, or volume that is specified in the input table is not found, as reported by the SMS construct access services. • NO VOLUMES ASSOCIATED WITH STORAGE GROUP: Indicates that the storage group that is specified in the input table does not have any volumes, as reported by the SMS construct access services. • NO STORAGE GROUPS ASSOCIATED WITH COPY POOL: Indicates that the copy pool that is specified in the input table does not have any storage groups, as reported by the SMS construct access services. • DSN661I DSNADMIV THE MACRO LSPACE FAILED WITH RETURN CODE=<i>nn</i>

ADMIN_INFO_SSID stored procedure

The SYSPROC.ADMIN_INFO_SSID stored procedure returns the name of the connected Db2 subsystem.

GUI

Environment

ADMIN_INFO_SSID must run in a WLM-established stored procedure address space.

Authorization

To execute the CALL statement, the owner of the package or plan that contains the CALL statement must have one or more of the following privileges:

- The EXECUTE privilege on the ADMIN_INFO_SSID stored procedure
- Ownership of the stored procedure
- SYSADM authority

Syntax

The following syntax diagram shows the SQL CALL statement for invoking this stored procedure:

```
CALL SYSPROC.ADMIN_INFO_SSID ( subsystem-ID , return-code , message )
```

Option descriptions

subsystem-ID

Identifies the subsystem ID of the connected Db2 subsystem.

This is an output parameter of type VARCHAR(4).

return-code

Provides the return code from the stored procedure. Possible values are:

0

The call completed successfully.

12

The call did not complete successfully. The *message* output parameter contains messages describing the error.

This is an output parameter of type INTEGER.

message

Contains messages describing the error encountered by the stored procedure. If no error occurred, no message is returned.

This is an output parameter of type VARCHAR(1331).

Example

The following C language sample shows how to invoke ADMIN_INFO_SSID:

```
#include <stdio.h>
#include <stdlib.h>
#include <string.h>

/***** DB2 SQL Communication Area *****/
EXEC SQL INCLUDE SQLCA;
```

```

int main( int argc, char *argv[] )    /* Argument count and list    */
{
  /****** DB2 Host Variables *****/
  EXEC SQL BEGIN DECLARE SECTION;

  /* SYSPROC.ADMIN_INFO_SSID PARAMETERS */
  char      ssid[5];                /* DB2 subsystem identifier */
  long int  retcd;                  /* Return code */
  char      errmsg[1332];           /* Error message */
  EXEC SQL END DECLARE SECTION;

  /****** Call stored procedure SYSPROC.ADMIN_INFO_SSID *****/
  EXEC SQL CALL SYSPROC.ADMIN_INFO_SSID
              (:ssid, :retcd, :errmsg);

  return(retcd);
}

```

Output

The output of this stored procedure includes the following output parameters, which are described in “Option descriptions” on page 770:

- *subsystem-ID*
- *return-code*
- *message*



ADMIN_INFO_SQL stored procedure

The ADMIN_INFO_SQL stored procedure captures statistics about a Db2 subsystem, its objects, and applications and returns the results in a data set or as a result set. The result, often called "service SQL", is a standard diagnostic documentation format that helps IBM Support re-create and troubleshoot problems, such as a poorly performing SQL query.



The output from ADMIN_INFO_SQL is intended primarily for the use of IBM Support. The format and content of the output might change at any time.

For information about submitting the service SQL data to IBM Support, see [Contacting IBM Support about Db2 problems \(Troubleshooting problems in Db2\)](#).

Environment

ADMIN_INFO_SQL must run in a WLM-established stored procedures address space, where NUMTCB is a value in the range 40–60.

If you collect information by using PLAN_TABLE, ensure that the DSN_VIEWREF_TABLE table exists before you capture EXPLAIN information. Especially if the query contains a view, the availability of DSN_VIEWREF_TABLE helps to narrow the view so that it is specific to the query, rather than collecting all of the view dependencies. DSN_VIEWREF_TABLE must have the same qualifier as the PLAN_TABLE. This qualifier is the table-creator value, which is the first input parameter.

Authorization

To execute the CALL statement, the owner of the package or plan that contains the CALL statement must have one or more of the following privileges:

- The EXECUTE privilege on the ADMIN_INFO_SQL stored procedure
- Ownership of the stored procedure

- SYSADM authority

Optionally, you need authority to create data sets, or access existing data sets, if the information is collected into a data set.

Syntax

The following syntax diagram shows the SQL CALL statement for invoking this stored procedure:

```

▶▶ CALL — SYSPROC.ADMIN_INFO_SQL — ( — table-creator , — table-name , — catalog-creator , →
    ▶ — plan-info , — collect-ddl , — collect-stats , — collect-column-stats , — edit-ddl , →
    ▶ — edit-version-mode , — partition-rotation , — output-method , — output-info , — pmr-info , →
    ▶ — return-code , — message — ) ▶▶
  
```

Option descriptions

table-creator

Specifies the explicit qualifier for the object, the list of tables, or the plan table (PLAN_TABLE).

This is an input parameter of type VARCHAR(128) and cannot be null.

table-name

Specifies the name of a single user object, a list of objects, or the plan table (PLAN_TABLE).

Valid options are an object name, LIST_TABLE-*table*, or PLAN_TABLE. The *table* portion of the LIST_TABLE-*table* option is the name of a Db2 table that contains two columns, CREATOR and TABLE. These two columns drive the program to collect information. The PLAN_TABLE option uses the CREATOR and TNAME columns of the PLAN_TABLE to collect information. This option depends on the *plan_info* parameter to qualify tables as input. The reference point to the plan table must point to a base table only.

When you specify PLAN_TABLE, ensure that the DSN_VIEWREF_TABLE table exists before you execute EXPLAIN. The availability of DSN_VIEWREF_TABLE minimizes the size of the DDL information. DSN_VIEWREF_TABLE must have the same qualifier as the plan table. This qualifier is the *table-creator* value, which is the first input parameter.

The input for a single user object or a list of objects must be one of the following types of objects:

- Base table
- View
- Alias
- Clone table
- Created temporary table
- History table
- Materialized query table
- Implicitly created table for an XML column

The input parameter *table-creator* must be the qualifier for these tables.

This is an input parameter of type VARCHAR(128).

catalog-creator

Specifies the catalog to use for collection. The default catalog is SYSIBM. To use the default catalog, you can specify DEFAULT or SYSIBM.

This is an input parameter of type VARCHAR(128) and cannot be null.

plan-info

If the table that is specified by *table-name* is PLAN_TABLE, *plan-info* is a value of the following form, or NONE:

```
program-begin-queryno-end-queryno
```

The meanings of these variables are:

program

A value from the PROGNAME column of the PLAN_TABLE, or a pattern that specifies a set of PROGNAME values in the PLAN_TABLE. Any pattern that is valid in a LIKE predicate can be specified. *program* represents programs or packages for which ADMIN_INFO_SQL collects PLAN_TABLE information.

begin-queryno

A value from the QUERYNO column of the PLAN_TABLE. The value represents the lowest statement number for which ADMIN_INFO_SQL collects PLAN_TABLE information.

end-queryno

A value from the QUERYNO column of the PLAN_TABLE. The value represents the highest statement number for which ADMIN_INFO_SQL collects PLAN_TABLE information.

If *table-name* does not specify PLAN_TABLE, the *plan-info* value must be NONE.

This is an input parameter of type VARCHAR(150) and cannot be null.

collect-ddl

Specifies whether to collect DDL information. Valid values are Y, N, 0 (zero), 1, 2, 3, or 4.

This is an input parameter of type CHAR(1) and cannot be null.

When the input table is not PLAN_TABLE, possible values are:

N

Do not return the data definition language statements that created the objects.

Y

Return the data definition language statements that created:

- The input objects
- Foreign keys that reference the input objects
- Views on the input objects

0

Return the data definition language statements that created:

- The input objects. Statements that create views on the input objects or foreign keys that reference the input objects are not collected.

1

Return the data definition language statements that created:

- The input objects
- Views on the input objects

2

Return the data definition language statements that created:

- The input objects
- Foreign keys that reference the input objects

3

Return the data definition language statements that created:

- The input objects
- Foreign keys that reference the input objects

- Views on the input objects
- Other objects that depend on the input objects, such as materialized query tables

This option can result in a large amount of data. Do not specify this option for problem analysis except at the direction of IBM Support.

4

Return the same data definition language statements that are returned when option Y is specified.

When the input table is PLAN_TABLE, possible values are:

N

Do not return the data definition language statements that created the objects.

Y

Return the data definition language statements that created:

- The objects that are identified by *plan-info*
- Foreign keys that reference the objects that are identified by *plan-info*
- If DSN_VIEWREF_TABLE exists and is populated, views or materialized query tables that are used to process the queries that are identified by *plan-info*.
- If DSN_VIEWREF_TABLE does not exist, views on objects that are identified by *plan-info*.

0

Return the data definition language statements that created:

- The objects that are identified by *plan-info* only. Statements that create views on the objects or foreign keys that reference the objects that are identified by *plan-info* are not collected.

1

Return the data definition language statements that created:

- The objects that are identified by *plan-info*
- If DSN_VIEWREF_TABLE exists and is populated, views or materialized query tables that are used to process the queries that are identified by *plan-info*.
- If DSN_VIEWREF_TABLE does not exist, views on objects that are identified by *plan-info*.

2

Return the data definition language statements that created:

- Foreign keys that reference the objects that are identified by *plan-info*

3

Return the data definition language statements that created:

- The objects that are identified by *plan-info*
- Foreign keys that reference the objects that are identified by *plan-info*
- Views on objects that are identified by *plan-info*
- Other objects that depend on the objects that are identified by *plan-info*, such as materialized query tables

This option can result in a large amount of data. Do not specify this option for problem analysis by IBM Support unless they direct you to do so.

4

Return the data definition language statements that created:

- The objects that are identified by *plan-info*
- Foreign keys that reference the objects that are identified by *plan-info*
- Views on objects that are identified by *plan-info*

This option does not use information from DSN_VIEWREF_TABLE.

collect-stats

Specifies whether to collect statistics information. Valid values are Y for yes, or N for no.

This is an input parameter of type CHAR(1) and cannot be null.

collect-column-stats

Specifies whether to collect column-level statistics information. Valid values are Y for yes, or N for no.

To collect column statistics, the *collect-stats* parameter must be set to Y.

This is an input parameter of type CHAR(1) and cannot be null.

edit-ddl

Specifies whether to edit the DDL output. Valid values are Y for yes, or N for no.

If edited, the DDL output contains changes, such as the STOGROUP set to SYSDEFLT, PRIQTY and SECQTY set to minimum values, and FOREIGNKEY definitions commented out. Sometimes IBM Support needs DDL output that is not edited. However, if the data to populate the DDL-defined tables will not be sent with the problem report, specify Y for this parameter.

This is an input parameter of type CHAR(1) and cannot be null.

edit-version-mode

Specifies that the output format for a different version and mode of Db2 for z/OS than is currently running when collecting information. In most cases, specify NONE, so that the output is not converted to another format. Otherwise, you must specify the version number and the mode.

Valid values for mode are C for conversion mode and N for new-function mode. For example, if you want to generate the output in the format used by Db2 11 new-function mode, specify 11-N.

This is an input parameter of type CHAR(4) and cannot be null.

partition-rotation

Specifies whether you want to verify the number of partition rotations that are required to balance the table. Valid values are Y for yes, or N for no.

This is an input parameter of type CHAR(1) and cannot be null.

output-method

Specifies the data set attributes that you want the output to include.

This is an input parameter of type CHAR(1) and cannot be null.

Possible values for *output-method* are:

Q

Returns dynamically created data sets with size parameters.

N

Returns the result data sets in an already existing data set in the WLM environment.

D

Returns dynamically created data sets on a volume that you specify.

R

Returns a result set in a predetermined format.

Output data sets and result sets contain the following information:

DDL

The creation statements for databases, table spaces, tables, and indexes.

SQL

INSERT statements for PLAN_TABLE, DSN_PROFILE_TABLE, DSN_PROFILE_ATTRIBUTES, and SYSACCELERATORS if the tables exist.

STATS

Statistical information related to the tables.

COLST

Statistical information related to the columns.

EXPL

The output begins with a first-pass analysis report, which contains the following information, if it is available:

- A report on missing EXPLAIN tables
- A report on statistics that are recommended but were not collected
- Results of a preliminary analysis of the EXPLAIN data

The following information is also returned:

- Visual output of the following tables, if they exist: PLAN_TABLE, DSN_PREDICAT_TABLE, DSN_DETCOST_TABLE, DSN_PROFILE_TABLE, DSN_PROFILE_ATTRIBUTES, and SYSACCELERATORS
- Information about the objects, messages, and input parameters.

The output also contains the following reports which describe object structures in relation the query:

- A table report contains information about the table space, table, and index key columns, organized by table space. It includes information about multi-column and index key cardinality.
- An index report that maps index details to predicates.

PARM

Subsystem parameter, service, module, and relational data system (RDS) MEPL information.

output-info

Specifies the output information. The values that you specify depend on the value of the *output-method* parameter.

This is an input parameter of type VARCHAR(1024) and cannot be null.

Based on the value of *output-method*, you must format the input for *output-info* as follows:

output-method = Q

This output method has the following format:

```
qualifier-primary(value or DEFLT)-secondary(value or DEFLT)
```

You specify a 29-character qualifier, including periods. You also can specify a primary and secondary track value. The default value is 200 for primary and 200 for secondary.

The result data set is created on temporary storage as a data set with one of the following types:

- .DDL
- .SQL
- .STATS
- .COLST
- .EXPL
- .PARM

The file might be deleted in a short period of time, depending on the configuration of your z/OS system. Because the data set is created as a new one, existing data sets with the same name are deleted.

If *pmr-info* specifies a support case ID, the data set names are created with the following format, with the case ID numbers split into two parts:

```
Tnnnnn.Snnnn.Ddddddd.Ttttttt.VXX.file-type
```

For example, for support case TS123456789, the ADMIN_INFO_SQL stored procedure generates data sets with names in the following format: T12345.S6789.D190801.T170318.VXX.type

If *pmr-info* specifies a PMR number, the DEFAULT value creates a data set name with the following format:

```
PMxxxxxx.Dxxxxxx.Txxxxxx.VXX.file-type
```

For example, for PMR 12345, the ADMIN_INFO_SQL stored procedure generates data sets with the following name format: PM12345.D091007.T170318.VXX.type

output-method = N

For established data sets in the WLM environment, you must specify the DD name in the following format:

```
DDL_DDname-SQL_DDname-Stats_DDname-Colst_DDname-Expl_DDname-  
Parm_DDname
```

The WLM administrator must create these data sets with DD names in the WLM startup procedure and supply those names to the person calling the stored procedure. These data sets can be generational. You must create the data sets as new ones rather than appending existing data sets. The ADMIN_INFO_SQL stored procedure opens the data set at initialization and closes the file when complete.

output-method = D

You specify the volume where you want the data sets created and the names and sizes of the data sets. This output method has the following format but in one continuous line with no spaces:

```
DDL;DSname(DEFAULT);volser;alcunit(TRK or CYL);primary;secondary-  
SQL;DSname(DEFAULT);volser;alcunit(TRK or CYL);primary;secondary-  
STATS;DSname(DEFAULT);volser;alcunit(TRK or CYL);primary;secondary-  
COLST;DSname(DEFAULT);volser;alcunit(TRK or CYL);primary;secondary-  
EXPL;DSname(DEFAULT);volser;alcunit(TRK or CYL);primary;secondary-  
PARM;DSname(DEFAULT);volser;alcunit(TRK or CYL);primary;secondary
```

The DEFAULT value creates the data set name with the same format and types as for output method Q. The data set name must contain the type identifier (for example, .DDL, .SQL, .STATS, etc.). As a result, the data sets can be listed in any order.

These data sets are created with the option *disp=(NEW, CATLG, KEEP)*. Therefore, if a data set with the same name already exists, the ADMIN_INFO_SQL stored procedure generates an error.

output-method = R

You must specify NONE. This output method returns a result set in the following format:

```
EXEC SQL CREATE GLOBAL TEMPORARY TABLE SYSIBM.SERVICE_SQL_OUTPUT  
(TID INTEGER NOT NULL, SEQNO INTEGER NOT NULL,  
TEXT VARCHAR(4096) NOT NULL);
```

Where TEXT is the information in the result set, such as DDL statements, statistical information, and service and module information. SEQNO is the sequence number in the table, and TID is the table number. For example:

Table 138. Table numbers for result set information

Table number (TID)	Result set information
1	DDL
2	SQL
3	STATS
4	COLST
5	EXPL
6	PARM

The following table shows the format of the result set that is returned in the created global temporary table SYSIBM.SERVICE_SQL_OUTPUT:

Table 139. Result set row for ADMIN_INFO_SQL result set

Column name	Data type	Contents
TID	INTEGER NOT NULL	The table number.
SEQNO	INTEGER NOT NULL	The sequence number in the table.
TEXT	VARCHAR(4096)	The information in the result set, such as DDL statements, statistical information, and service and module information.

The following DECLARE statement shows the data that is returned for the result set and the order that the data is returned in:

```
EXEC SQL DECLARE DATA_CSR CURSOR WITH RETURN WITH HOLD FOR
SELECT TID, SEQNO, TEXT FROM SYSIBM.SERVICE_SQL_OUTPUT
ORDER BY TID, SEQNO;
```

pmr-info

Specifies one of the following values:

- The support case ID in TSnnnnnnnnn format, where nnnnnnnnn is a 9-digit number.
- The PMR number, branch code and country code in xxxxx.yyy.zzz format, where xxxxx is the PMR number, yyy is the branch code, and zzz is the country code.

This is an input parameter of type VARCHAR(13) and cannot be null.

return-code

Provides the return code from the stored procedure. Possible values are:

- 0** The call completed successfully.
- 4** Warning. The *message* output parameter contains messages describing the warning.
- 12** The call did not complete successfully. The *message* output parameter contains messages describing the error.

This is an output parameter of type INTEGER.

message

Contains messages describing the error or warning encountered by the stored procedure. If no error occurred, the message states "DSNADMSS completed successfully."

The first messages in this area are generated by the stored procedure. Messages that are generated by Db2 might follow the first messages.

This is an output parameter of type VARCHAR(1331).

Examples

You can invoke the call for the ADMIN_INFO_SQL stored procedure from a Db2 command line processor, if you have access to a z/OS server. You also can call this stored procedure by using Java JDBC applications and by using the C language.

In addition, you can use DSNADMSB, an IBM-supplied program, to call the ADMIN_INFO_SQL stored procedure. The result set is returned in a data set or as part of the job stream.

Example 1: The following example calls the ADMIN_INFO_SQL stored procedure to collect information from the PLAN_TABLE for program APROGRAM and query numbers between 1 and 12345.

```
CALL SYSPROC.ADMIN_INFO_SQL('sysadm','PLAN_TABLE','DEFAULT',
'APROGRAM-1-12345','Y','Y','N','Y','NONE','N','D','DDL;DEFAULT;EDSDMP;
TRK;200;200-SQL;DEFAULT;EDSDMP;TRK;200;200-STATS;DEFAULT;EDSDMP;TRK;200;200
-COLST;DEFAULT;EDSDMP;TRK;200;200-EXPL;DEFAULT;EDSDMP;TRK;200;200
-PARM;DEFAULT;EDSDMP;TRK;200;200','TS123456789',?,?);
```

The output is created in data sets on volume EDSAMP with 200 primary tracks and 200 secondary tracks. These data sets have the following naming convention:

- T12345.S6789.D190801.T170318.VXX.COLST
- T12345.S6789.D190801.T170318.VXX.DDL
- T12345.S6789.D190801.T170318.VXX.EXPL
- T12345.S6789.D190801.T170318.VXX.PARM
- T12345.S6789.D190801.T170318.VXX.SQL
- T12345.S6789.D190801.T170318.VXX.STATS

Example 2: The following example of the ADMIN_INFO_SQL stored procedure uses the list table TL1 to collect data from all of the base tables whose names are specified by rows in TL1. The following SQL statements show how to create and populate the list table:

```
DROP TABLE TL1;
DROP DATABASE DL1;
COMMIT;
CREATE DATABASE DL1;
CREATE TABLESPACE TSL1 IN DL1;
CREATE TABLE TL1 (CREATOR VARCHAR(128), TABLE VARCHAR(128)) IN DL1.TSL1;
COMMIT;
INSERT INTO TL1 VALUES ('SYSADM','T1');
INSERT INTO TL1 VALUES ('SYSADM','T2');
INSERT INTO TL1 VALUES ('SYSADM','T3');
COMMIT;
```

The following CALL statement for the ADMIN_INFO_SQL stored procedure returns a single result set in the job stream. The list table name must be preceded by 'LIST_TABLE-':

```
CALL SYSPROC.ADMIN_INFO_SQL('SYSADM','LIST_TABLE-TL1','DEFAULT','NONE','Y','Y',
'N','Y','NONE','N','R','NONE','TS123456789',?,?);
```

Even though the column name is TABLE in the list table, the input for a list of objects can be any of the following types of objects:

- Base table
- View
- Alias
- Clone table
- Created temporary table
- History table
- Materialized query table
- Implicitly created table for an XML column

Example 3: You also can call this stored procedure by using Java JDBC applications or by using the C language. The following examples call the ADMIN_INFO_SQL stored procedure to collect information from the PLAN_TABLE for program APROGRAM and query numbers in the range 1–12345, and return a result set.

Java JDBC code snippet example:

```
try
{
    pstmt = conn.prepareStatement("CALL SYSPROC.ADMIN_INFO_SQL(?,?,?,?,?,?,"
        + "?,?,?,?,?,?)");
    // Create a CallableStatement object
    pstmt.setString (1, "sysadm");
    pstmt.setString (2, "PLAN_TABLE");
    pstmt.setString (3, "DEFAULT");
    pstmt.setString (4, "APROGRAM-1-12345");
    pstmt.setString (5, "Y");
    pstmt.setString (6, "Y");
    pstmt.setString (7, "Y");
    pstmt.setString (8, "N");
    pstmt.setString (9, "NONE");
    pstmt.setString (10, "N");
    pstmt.setString (11, "R");
    pstmt.setString (12, "NONE");
    pstmt.setString (13, "TS123456789");
    // Set input parameters (DB2 command)
    pstmt.registerOutParameter (14, Types.INTEGER);
    pstmt.registerOutParameter (15, Types.VARCHAR);
    // Register output parameters

    boolean resultsAvailable = pstmt.execute();
    rc = pstmt.getInt(14); // Get the output parameter values
    errbuff = pstmt.getString(15);

    while (resultsAvailable)
    {
        ResultSet rs = pstmt.getResultSet();
        while (rs.next())
        {
            String s = rs.getString(3);
            System.out.println(s);
        }

        rs.close();
        resultsAvailable = pstmt.getMoreResults();
    }
}
```

C language code snippet example:

```
EXEC SQL CALL SYSPROC.ADMIN_INFO_SQL ('sysadm','PLAN_TABLE'
,'DEFAULT', 'APROGRAM-1-12345','Y','Y','N','Y','9-N','N','R',
'NONE','TS123456789',:out1,:out2);
printf( "%d CALL SQLCODE\n", SQLCODE);
printf( "%d CALL RC\n", out1);
printf( "%s CALL DETAILS\n", out2);

if(SQLCODE==+466)
{
    EXEC SQL ASSOCIATE LOCATORS (:loc1) WITH
    PROCEDURE SYSPROC.ADMIN_INFO_SQL;
    printf( "%d ASSOC SQLCODE\n", SQLCODE);

    EXEC SQL ALLOCATE C1 CURSOR FOR RESULT SET :loc1;
    printf( "%d ALLOC SQLCODE\n", SQLCODE);

    while(SQLCODE==0)
    {
        DATA.LNG = 0;
        SEQNO = 0;
        TID = 0;

        ind1 = -1;
        ind2 = -1;
        ind3 = -1;

        EXEC SQL FETCH C1 INTO :TID :ind1, :SEQNO :ind2, :DATA :ind3;
        memcpy(output, DATA.THEDATA, DATA.LNG);
        output??(DATA.LNG??) = '\0';
        printf( "%s\n", output);
    }
}
printf( "%d FETCH SQLCODE\n", SQLCODE);
```

Output

This stored procedure returns the following output parameters, which are described in “[Option descriptions](#)” on page 772:

- *return-code*
- *message*

In addition, this stored procedure returns output in data sets or a result set. You must ensure that enough space is available for the output. The ADMIN_INFO_SQL stored procedure might generate large amounts of data. Two to three megabytes of space is the average, but larger workloads might generate up to 20 megabytes of data. To conserve space, set the *collect-column-stats* option to N.

◀ PSPI

Related tasks

[Collecting service SQL documentation \(Troubleshooting problems in Db2\)](#)

[Debugging ADMIN_INFO_SQL \(Db2 Administration Guide\)](#)

Related reference

[DSNTEJ6I \(Db2 Programming samples\)](#)

[DSNADMSB \(Db2 Utilities\)](#)

Related information

[Introducing SYSPROC.ADMIN_INFO_SQL \(IBM developerWorks\)](#)

ADMIN_INFO_SYSLOG stored procedure

The ADMIN_INFO_SYSLOG stored procedure returns system log entries. You can specify filters, such as search string, system name, begin date and time, end date and time, and maximum number of entries, to limit the number of system log entries that are returned.

Environment

◀ GUPI

ADMIN_INFO_SYSLOG runs in a WLM-established stored procedures address space, where TCB=1 is required.

Authorization

To use ADMIN_INFO_SYSLOG, you need to be licensed to use the SDSF utility. The ADMIN_INFO_SYSLOG stored procedure uses the SDSF ISFEXEC host command to issue the SDSF command MAS, and the SDSF ISFLOG host command to access the SYSLOG. These commands are issued under the security context of the user who is calling ADMIN_INFO_SYSLOG. SDSF determines the user command authority in the same way that it does when the user issues the SDSF commands MAS and LOG in an interactive mode. For more information about granting access to SDSF commands, see [z/OS SDSF Operation and Customization](#).

Syntax

The following syntax diagram shows the SQL CALL statement for invoking this stored procedure:

```
▶▶ CALL — SYSPROC.ADMIN_INFO_SYSLOG — ( — search-filter , — system-name , — start-date , →  
▶ — start-time , — end-date , — end-time , — max-entries , — message — ) ▶▶
```

Option descriptions

search-filter

Specifies a logical expression that is used to filter the SYSLOG records. If this parameter is set to NULL or is empty, filtering is not done.

A logical expression is composed of one or more operands, separated by operators. For example:

```
operand operator operand operator operand ... operator operand
```

where:

- `operator` is one of the following logical operators:
 - AND
 - and
 - OR
 - or
- `operand` is a string of characters, or a string of characters enclosed in quotation marks.

The operand is used unchanged to search and locate a system log record. Therefore, characters such as '*', '%', and '?' are not handled as masking characters.

If an operand is enclosed in quotations marks and you want to include quotation marks in the operand, use two sets of quotation marks. If an operand includes one or more blanks or the logical operators (AND, and, OR, or), enclose the string of characters in quotations marks.

For a multi-line message, each operand in the *search-filter* parameter is checked against each line of the multi-line message. A match is found if the operand is in at least one line of the multi-line message. If the operand is split over several lines, a match is not found. If the whole message satisfies the *search-filter*, the whole message is returned.

JES3 DLOG does not have a column that indicates whether a line is a continuation of a previous line. For a multi-line message, the filter is applied separately on each line in the message, and only matching lines (not the whole message) are returned.

This is an input parameter of type VARCHAR(1300).

system-name

Specifies the system in the sysplex where the system log entries will be processed or searched. Specify NULL if you are retrieving SYSLOG records for the z/OS subsystem where the stored procedure is running. Specify "*" (an asterisk) if you want all of the systems in a sysplex to be processed. The following restrictions apply:

- If the stored procedure is running in a JES2 system, specifying "*" causes the stored procedure to process only the logical SYSLOG of every active JES2 system in the sysplex.
- If the stored procedure is running in a JES3 system, specifying "*" causes the stored procedure to process the logical SYSLOG of every active JES3 system in the sysplex. All DLOG entries in the global SYSLOG that are within the specified time interval, which can contain messages from every JES2 and JES3 system in the sysplex, will also be returned.

This is an input parameter of type VARCHAR(8).

start-date

Specifies the starting date for system log records to be processed. If this parameter is set to NULL, the default is the current date.

This is an input parameter of type DATE.

start-time

Specifies the starting time for system log records to be processed. If this parameter is set to NULL, the default time is 00:00:00.

This is an input parameter of type TIME.

end-date

Specifies the ending date for system log records to be processed. If this parameter is set to NULL, the default is the current date.

This is an input parameter of type DATE.

end-time

Specifies the ending time for system log records to be processed. If this parameter is set to NULL, the default time is 23:59:59.

This is an input parameter of type TIME.

Together, *start-date*, *start-time*, *end-date*, and *end-time* define the date and time range for the SYSLOG records. The starting date and time must be less than the ending date and time. SDSF positions the SYSLOG as close as possible to the requested record. However, due to the precision that is used for timestamps and the time that the record is actually written to SYSLOG, the time parameters might be several lines away from the record that you want. SYSLOG records from before a specified time interval might be returned, while SYSLOG records that are closer to a specified ending date and time might not be returned.

max-entries

Specifies a limit for the number of SYSLOG records to be processed for each system. If this parameter is set to NULL, the default is 500. Valid values are 1 to 99999999 and -1 to -99999999.

If *max-entries* is a positive number, the stored procedure processes only the oldest *max-entries* records for a specified time interval. If the limit for records occurs in the middle of a message, the message will be truncated if returned by the stored procedure.

If *max-entries* is a negative number, the stored procedure processes only the most current *max-entries* records for the specified time interval. If the limit for records occurs in the middle of a message, the message will be truncated if returned by the stored procedure.

Note: If you specified the *search-filter* parameter, the value specified for *max-entries* is not the maximum number of result set rows to be returned for a system. The number of rows that are returned in a result set for a system is always less than or equal to *max-entries*.

This is an input parameter of type INTEGER.

message

Contains messages that describe errors that occurred during stored procedure processing. The first messages are generated by the stored procedure. Messages that are generated by ISFEXEC or ISFLOG might follow the stored procedure messages.

If the stored procedure completed successfully, no message is returned.

This is an output parameter of type VARCHAR(1331).

Output

This stored procedure returns the following output parameters, which are described in [“Option descriptions”](#) on page 782:

- *message*

In addition to the preceding output, the stored procedure returns one result set that contains the system log records that you requested.

The following table shows the format of the result set that is returned in the created global temporary table SYSIBM.SYSLOG:

Table 140. Result set row for ADMIN_INFO_SYSLOG result set

Column name	Data type	Contents
ROWNUM	INTEGER NOT NULL	Sequence number of the table row, from 1 to <i>n</i> .
TEXT	VARCHAR(130) NOT NULL	A system log entry. For multi-line messages, a row is returned for each line in the message.

The result set rows are returned in ascending order by ROWNUM. The system log records that are returned are grouped by system. Within each system, the system log records are returned in the same order as they appear in the SDSF system log.



ADMIN_INFO_SYSPARM stored procedure

The SYSPROC.ADMIN_INFO_SYSPARM stored procedure returns the system parameters, application defaults module, and IRLM parameters of a connected Db2 subsystem, or member of its data sharing group.

Environment



ADMIN_INFO_SYSPARM runs in a WLM-established stored procedures address space, where NUMTCB=1 is required.

Authorization

To execute the CALL statement, the owner of the package or plan that contains the CALL statement must have one or more of the following privileges on each package that the stored procedure uses:

- The EXECUTE privilege on the package for DSNADMIZ
- Ownership of the package
- PACKADM authority for the package collection
- SYSADM authority

The user who calls this stored procedure must have MONITOR1 privilege.

Syntax

The following syntax diagram shows the SQL CALL statement for invoking this stored procedure:

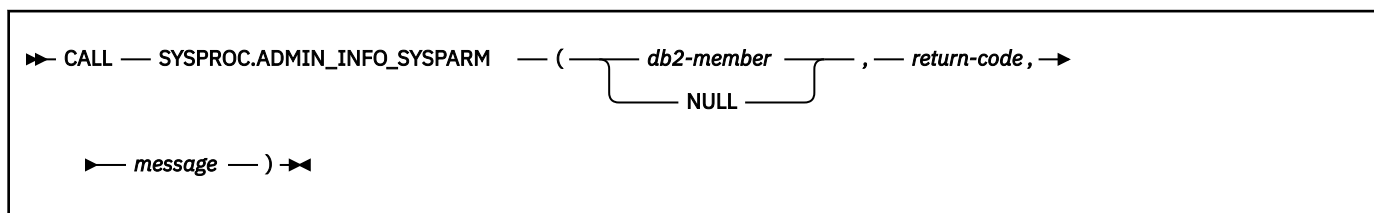

Option descriptions

db2-member

Specifies the name of the Db2 data sharing group member that you want to get the system parameters, DSNHDECP or a user-specified application defaults module, and IRLM parameters from.

Specify NULL for this parameter if you are retrieving the system parameters, DSNHDECP values, and IRLM parameters from the connected Db2 subsystem.

This is an input parameter of type VARCHAR(8).

return-code

Provides the return code from the stored procedure. The following values are possible:

0

The call completed successfully.

12

The call did not complete successfully. The *message* output parameter contains messages that describe the IFI error or SQL error that is encountered by the stored procedure.

This is an output parameter of type INTEGER.

message

Contains messages that describe the IFI error or SQL error that was encountered by the stored procedure. If an error did not occur, a message is not returned.

This is an output parameter of type VARCHAR(1331).

Example

The following C language sample shows how to invoke ADMIN_INFO_SYSPARM:

```
#include <stdio.h>
#include <stdlib.h>
#include <string.h>

/***** DB2 SQL Communication Area *****/
EXEC SQL INCLUDE SQLCA;

int main( int argc, char *argv[] ) /* Argument count and list */
{
    /***** DB2 Host Variables *****/
    EXEC SQL BEGIN DECLARE SECTION;

    /* SYSPROC.ADMIN_INFO_SYSPARM parameters */
    char db2_member[9]; /* Data sharing group member */
    short int ind_db2_member; /* Indicator variable */
    long int retcd; /* Return code */
    short int ind_retcd; /* Indicator variable */
    char errmsg[1332]; /* Error message */
    short int ind_errmsg; /* Indicator variable */
    /* Result set locators */
    volatile SQL TYPE IS RESULT_SET_LOCATOR VARYING *rs_loc1;
    /* Result set row */
    long int rownum; /* Sequence number of the */
    /* table row (1,...,n) */
    char macro[9]; /* Macro that contains the */
    /* system parameter, or */
    /* DSNHDECP parameter, or the */
    /* name of the IRLM procedure */
    /* that z/OS invokes if IRLM */
    /* is automatically started */
    /* by DB2 */
    char parameter[41]; /* Name of the system */
    /* parameter, DSNHDECP */
    /* parameter, or IRLM */
    /* parameter */
    char install_panel[9]; /* Name of the installation */
    /* panel where the parameter */
    /* value can be changed when */
    /* installing or migrating DB2*/
    short int ind_install_panel; /* Indicator variable */
    char install_field[41]; /* Name of the parameter on */
    /* the installation panel */
    short int ind_install_field; /* Indicator variable */
    char install_location[13]; /* Location of the parameter */
    /* on the installation panel */
    short int ind_install_location; /* Indicator variable */
    char value[2049]; /* Value of the parameter */
    char additional_info[201]; /* Reserved for future use */
    short int ind_additional_info; /* Indicator variable */
}
```

```

EXEC SQL END DECLARE SECTION;
/*****
/* Set the db2_member indicator variable to -1 to get the DB2
/* subsystem parameters, DSNHDECP values, and IRLM parameters of
/* the connected DB2 subsystem.
*****/
ind_db2_member = -1;
/*****
/* Call stored procedure SYSPROC.ADMIN_INFO_SYSPARM
*****/
EXEC SQL CALL SYSPROC.ADMIN_INFO_SYSPARM
           (:db2_member :ind_db2_member,
           :retcd       :ind_retcd,
           :errmsg      :ind_errmsg);
/*****
/* Retrieve result set when the SQLCODE from the call is +446,
/* which indicates that result sets were returned
*****/
if (SQLCODE == +466) /* Result sets were returned
{
  /* Establish a link between the result set and its locator
  EXEC SQL ASSOCIATE LOCATORS (:rs_loc1)
        WITH PROCEDURE SYSPROC.ADMIN_INFO_SYSPARM;
  /* Associate a cursor with the result set
  EXEC SQL ALLOCATE C1 CURSOR FOR RESULT SET :rs_loc1;
  /* Perform fetches using C1 to retrieve all rows from the
  /* result set
  EXEC SQL FETCH C1
        INTO :rownum, :macro, :parameter,
             :install_panel      :ind_install_panel,
             :install_field      :ind_install_field,
             :install_location   :ind_install_location,
             :value,
             :additional_info     :ind_additional_info;

  while(SQLCODE==0)
  {
    EXEC SQL FETCH C1
          INTO :rownum, :macro, :parameter,
               :install_panel      :ind_install_panel,
               :install_field      :ind_install_field,
               :install_location   :ind_install_location,
               :value,
               :additional_info     :ind_additional_info;

  }

  EXEC SQL CLOSE C1;
}
return(retcd);
}

```

Output

This stored procedure returns the following output parameters, which are described in “[Option descriptions](#)” on page 784:

- *return-code*
- *message*

In addition to the preceding output, the stored procedure returns one result set that contains the parameter settings.

The following table shows the format of the result set that is returned in the created global temporary table SYSIBM.DB2_SYSPARM:

Table 141. Result set row for ADMIN_INFO_SYSPARM result set

Column name	Data type	Contents
ROWNUM	INTEGER NOT NULL	Sequence number of the table row, from 1 to n.

Table 141. Result set row for ADMIN_INFO_SYSPARM result set (continued)

Column name	Data type	Contents
MACRO	VARCHAR(8) NOT NULL	Macro that contains the system parameter, the <i>dsnhdcp</i> parameter, or the name of the IRLM procedure that z/OS invokes if IRLM is started automatically by Db2.
PARAMETER	VARCHAR(40) NOT NULL	Name of the system parameter, <i>dsnhdcp</i> parameter, or IRLM parameter.
INSTALL_PANEL	VARCHAR(8)	Name of the installation panel where the parameter value can be changed when installing or migrating Db2.
INSTALL_FIELD	VARCHAR(40)	Name of the parameter on the installation panel.
INSTALL_LOCATION	VARCHAR(12)	Location of the parameter on the installation panel.
VALUE	VARCHAR(2048) NOT NULL	The value of the parameter. ¹ on page 787
ADDITIONAL_INFO	VARCHAR(200)	Specifies whether a parameter can be updated online. If the value is null, the stored procedure could not retrieve the information for the parameter.

1. See “Parameter values that are returned in bit format” on [page 787](#) for information on how to interpret entries in the VALUE column that are in bit format.

Parameter values that are returned in bit format

For certain subsystem parameters, the content of the VALUE column in the returned result set is a bit string.

For subsystem parameters AUDITST, MON, and SMFACCT, the 32 bits of the string correspond to the 32 trace classes. The bit string has the following values:

- If the subsystem parameter value is NO, all bits are 0.
- If the subsystem parameter value is YES, the first bit is 1, and all other bits are 0.
- If the subsystem parameter value is *, all bits are 1.
- Otherwise, the bits that are 1 correspond to the trace classes that are on. For example, if the AUDITST subsystem parameter specification is AUDITST=(1,3,5), the first, third and fifth bits of the bit string are 1, and all other bits are 0:

```
10101000000000000000000000000000
```

For subsystem parameters ROUTCDE and ARCWRCT, the 16 bits of the string correspond to the 16 route codes. The bit string has the following values:

- The bits that are 1 correspond to the route codes that are on. For example, if the ROUTCDE subsystem parameter specification is ROUTCDE=(1,3), the first and third bits of the bit string are 1, and all other bits are 0:

```
101000000000000000
```

For subsystem parameter SMFSTAT, the 32 bits of the string correspond to the 32 trace classes. The bit string has the following values:

- If the subsystem parameter value is NO, all bits are 0.
- If the subsystem parameter value is YES, the first, third, fourth, fifth, and sixth bits are 1, and all other bits are 0.
- If the subsystem parameter value is *, all bits are 1.
- Otherwise, the bits that are 1 correspond to the trace classes that are on. For example, if the SMFSTAT subsystem parameter specification is SMFSTAT=(1,3,5), the first, third and fifth bits of the bit string are 1, and all other bits are 0:

```
1010100000000000000000000000000000000000
```

For subsystem parameter TRACSTR, the 32 bits of the string correspond to the 32 trace classes. The bit string has the following values:

- If the subsystem parameter value is NO, all bits are 0.
- If the subsystem parameter value is YES, the first, second, and third bits are 1, and all other bits are 0.
- If the subsystem parameter value is *, all bits are 1.
- Otherwise, the bits that are 1 correspond to the trace classes that are on. For example, if the TRACSTR subsystem parameter specification is TRACSTR=(1,3,5), the first, third and fifth bits of the bit string are 1, and all other bits are 0:

```
1010100000000000000000000000000000000000
```



ADMIN_JOB_CANCEL stored procedure

The SYSPROC.ADMIN_JOB_CANCEL stored procedure purges or cancels a job.

Environment



The load module for ADMIN_JOB_CANCEL, DSNADMJP, must reside in an APF-authorized library. ADMIN_JOB_CANCEL runs in a WLM-established stored procedure address space, and all libraries in this WLM procedure STEPLIB DD concatenation must be APF-authorized.

The load module for ADMIN_JOB_CANCEL, DSNADMJP, must be program controlled if the BPX.DAEMON.HFCTL FACILITY class profile has not been set up. For information on how to define DSNADMJP to program control, see installation job DSNTIJRA.

Authorization

To execute the CALL statement, the owner of the package or plan that contains the CALL statement must have one or more of the following privileges:

- The EXECUTE privilege on the ADMIN_JOB_CANCEL stored procedure
- Ownership of the stored procedure
- SYSADM authority

The user specified in the *user-ID* input parameter of the SQL CALL statement also needs authorization from an external security system, such as RACF, in order to perform the requested operation.

Syntax

The following syntax diagram shows the SQL CALL statement for invoking this stored procedure:

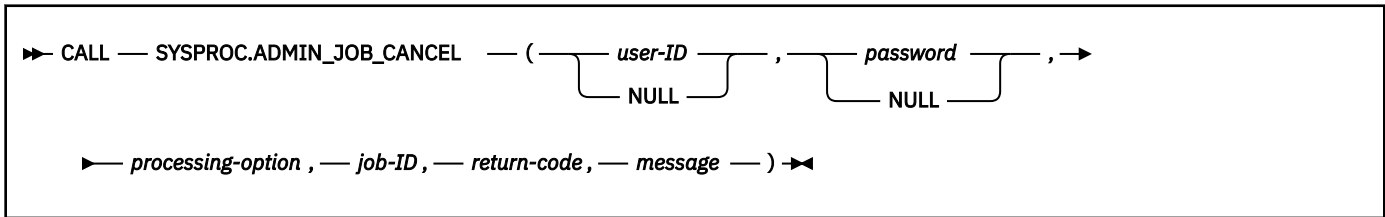

Option descriptions

user-ID

Specifies the user ID under which the job is canceled or purged.

If *user-ID* is NULL, *password* must also be NULL. If the *user-ID* and *password* values are NULL, the login process uses the primary authorization ID of the process.

You can specify NULL for this parameter in the following circumstances:

- The authorization ID that is associated with the stored procedure address space has daemon authority.
- The authorization ID that is associated with the stored procedure address space does not have daemon authority but is authorized to the BPX.SRV.*userid* SURROGAT class profile, where *userid* is the authorization ID of the stored procedure. For more information about how the RACF security administrator can authorize the authorization ID that is associated with the stored procedure address space to a SURROGAT class profile, see [Defining servers to process users without passwords or password phrases](#).

Daemon authority is given to any superuser that is permitted to the BPX.DAEMON FACILITY class profile. If the BPX.DAEMON FACILITY class profile is not defined, all superusers have daemon authority.

This is an input parameter of type VARCHAR(128).

password

Specifies the password associated with the input parameter *user-ID*.

The value of *password* is passed to the stored procedure as part of payload, and is not encrypted. It is not stored in dynamic cache when parameter markers are used.

If *password* is NULL, *user-ID* must also be NULL. If the *user-ID* and *password* values are NULL, the login process uses the primary authorization ID of the process.

You can specify NULL for this parameter in the following circumstances:

- The authorization ID that is associated with the stored procedure address space has daemon authority.
- The authorization ID that is associated with the stored procedure address space does not have daemon authority but is authorized to the BPX.SRV.*userid* SURROGAT class profile, where *userid* is the authorization ID of the stored procedure.

This is an input parameter of type VARCHAR(100).

processing-option

Identifies the type of command to invoke. Possible values are:

1

Cancel a job.

2

Purge a job.

This is an input parameter of type INTEGER and cannot be null.

job-ID

Specifies the job ID of the job to be canceled or purged. Acceptable formats are:

- Jnnnnnnn
- JOBnnnnn

where *n* is a digit in the range 0–9. For example: JOB01035

Both Jnnnnnnn and JOBnnnnn must be exactly 8 characters in length.

This is an input parameter of type CHAR(8) and cannot be null.

return-code

Provides the return code from the stored procedure. Possible values are:

0

The call completed successfully.

12

The call did not complete successfully. The *message* output parameter contains messages describing the error.

This is an output parameter of type INTEGER.

message

Contains messages describing the error encountered by the stored procedure. If no error occurred, then no message is returned.

The first messages in this area are generated by the stored procedure. Messages that are generated by z/OS might follow the first messages.

This is an output parameter of type VARCHAR(1331).

Example

The following C language sample shows how to invoke ADMIN_JOB_CANCEL:

```
#include <stdio.h>
#include <stdlib.h>
#include <string.h>

/***** DB2 SQL Communication Area *****/
EXEC SQL INCLUDE SQLCA;

int main( int argc, char *argv[] ) /* Argument count and list */
{
  /***** DB2 Host Variables *****/
  EXEC SQL BEGIN DECLARE SECTION;

  /* SYSPROC.ADMIN_JOB_CANCEL parameters */
  char   userid[129];          /* User ID */
  short int ind_userid;       /* Indicator variable */
  char   password[101];       /* Password */
  short int ind_password;     /* Indicator variable */
  long int procopt;           /* Processing option */
  short int ind_procopt;      /* Indicator variable */
  char   jobid[9];           /* Job ID */
  short int ind_jobid;        /* Indicator variable */
  long int retcd;             /* Return code */
  short int ind_retcd;        /* Indicator variable */
  char   errmsg[1332];        /* Error message */
  short int ind_errmsg;       /* Indicator variable */
  EXEC SQL END DECLARE SECTION;

  /***** Assign values to input parameters to purge a job
  /* Set the indicator variables to 0 for non-null input parameters */
  *****/
  strcpy(userid, "USRT001");
```

```

ind_userid = 0;
strcpy(password, "N1CETEST");
ind_password = 0;
procopt = 2;
ind_procopt = 0;
strcpy(jobid, "JOB00105");
ind_jobid = 0;

/*****
/* Call stored procedure SYSPROC.ADMIN_JOB_CANCEL */
/*****
EXEC SQL CALL SYSPROC.ADMIN_JOB_CANCEL
              (:userid   :ind_userid,
              :password  :ind_password,
              :procopt   :ind_procopt,
              :jobid     :ind_jobid,
              :retcd     :ind_retcd,
              :errmsg     :ind_errmsg);

return(retcd);
}

```

Output

This stored procedure returns the following output parameters, which are described in [“Option descriptions”](#) on page 789:

- *return-code*
- *message*



ADMIN_JOB_FETCH stored procedure

The SYSPROC.ADMIN_JOB_FETCH stored procedure retrieves SYSOUT from JES spool and returns the SYSOUT.

Environment



The load module for ADMIN_JOB_FETCH, DSNADMJF, must reside in an APF-authorized library. ADMIN_JOB_FETCH runs in a WLM-established stored procedure address space, and all libraries in this WLM procedure STEPLIB DD concatenation must be APF-authorized.

The load module for ADMIN_JOB_FETCH, DSNADMJF, must be program controlled if the BPX.DAEMON.HFSCTL FACILITY class profile has not been set up. For information on how to define DSNADMJF to program control, see installation job DSNTIJRA.

Authorization

To execute the CALL statement, the owner of the package or plan that contains the CALL statement must have one or more of the following privileges on each package that the stored procedure uses:

- The EXECUTE privilege on the package for DSNADMJF
- Ownership of the package
- PACKADM authority for the package collection
- SYSADM authority

Syntax

The following syntax diagram shows the SQL CALL statement for invoking this stored procedure:

```

▶ CALL — SYSPROC.ADMIN_JOB_FETCH — ( — user-ID — , — password — , —
      NULL — , — NULL — ) —▶
▶ — job-ID , — return-code , — message — ) —▶

```

Option descriptions

user-ID

Specifies the user ID under which SYSOUT is retrieved.

If *user-ID* is NULL, *password* must also be NULL. If the *user-ID* and *password* values are NULL, the login process uses the primary authorization ID of the process.

You can specify NULL for this parameter in the following circumstances:

- The authorization ID that is associated with the stored procedure address space has daemon authority.
- The authorization ID that is associated with the stored procedure address space does not have daemon authority but is authorized to the BPX.SRV.userid SURROGAT class profile, where 'userid' is the authorization ID of the stored procedure. For more information about how the RACF security administrator can authorize the authorization ID that is associated with the stored procedure address space to a SURROGAT class profile, see [Defining servers to process users without passwords or password phrases](#).

Daemon authority is given to any superuser that is permitted to the BPX.DAEMON FACILITY class profile. If the BPX.DAEMON FACILITY class profile is not defined, all superusers have daemon authority.

This is an input parameter of type VARCHAR(128).

password

Specifies the password associated with the input parameter *user-ID*.

The value of *password* is passed to the stored procedure as part of payload, and is not encrypted. It is not stored in dynamic cache when parameter markers are used.

If *password* is NULL, *user-ID* must also be NULL. If the *user-ID* and *password* values are NULL, the login process uses the primary authorization ID of the process.

You can specify NULL for this parameter in the following circumstances:

- The authorization ID that is associated with the stored procedure address space has daemon authority.
- The authorization ID that is associated with the stored procedure address space does not have daemon authority but is authorized to the BPX.SRV.userid SURROGAT class profile, where *userid* is the authorization ID of the stored procedure.

This is an input parameter of type VARCHAR(100).

job-ID

Specifies the JES2 or JES3 job ID whose SYSOUT data sets are to be retrieved.

This is an input parameter of type CHAR(8) and cannot be null.

return-code

Provides the return code from the stored procedure. Possible values are:

- 0 The call completed successfully.

12

The call did not complete successfully. The *message* output parameter contains messages describing the error.

This is an output parameter of type INTEGER.

message

Contains messages describing the error encountered by the stored procedure. If no error occurred, then no message is returned.

The first messages in this area are generated by the stored procedure. Messages that are generated by Db2 might follow the first messages.

This is an output parameter of type VARCHAR(1331).

Example

The following C language sample shows how to invoke ADMIN_JOB_FETCH:

```
#include <stdio.h>
#include <stdlib.h>
#include <string.h>

/***** DB2 SQL Communication Area *****/
EXEC SQL INCLUDE SQLCA;

int main( int argc, char *argv[] ) /* Argument count and list */
{
    /***** DB2 Host Variables *****/
    EXEC SQL BEGIN DECLARE SECTION;

    /* SYSPROC.ADMIN_JOB_FETCH parameters */
    char      userid[129];          /* User ID */
    short int ind_userid;          /* Indicator variable */
    char      password[101];       /* Password */
    short int ind_password;        /* Indicator variable */
    char      jobid[9];            /* Job ID */
    short int ind_jobid;           /* Indicator variable */
    long int  retcd;               /* Return code */
    short int ind_retcd;           /* Indicator variable */
    char      errmsg[1332];        /* Error message */
    short int ind_errmsg;          /* Indicator variable */

    /* Result set locators */
    volatile SQL TYPE IS RESULT_SET_LOCATOR *rs_loc1;

    /* Result set row */
    long int  rownum;              /* Sequence number of the */
    char      text[4097];          /* table row */
    EXEC SQL END DECLARE SECTION;

    /***** Assign values to input parameters to fetch the SYSOUT of a job */
    /* Set the indicator variables to 0 for non-null input parameters */
    strcpy(userid, "USRT001");
    ind_userid = 0;
    strcpy(password, "N1CETEST");
    ind_password = 0;
    strcpy(jobid, "JOB00100");
    ind_jobid = 0;

    /***** Call stored procedure SYSPROC.ADMIN_JOB_FETCH *****/
    EXEC SQL CALL SYSPROC.ADMIN_JOB_FETCH
                (:userid :ind_userid,
                :password :ind_password,
                :jobid :ind_jobid,
                :retcd :ind_retcd,
                :errmsg :ind_errmsg);

    /***** Retrieve result set when the SQLCODE from the call is +446, */
    /* which indicates that result sets were returned */
}
```

```

if (SQLCODE == +466)          /* Result sets were returned */
{
  /* Establish a link between the result set and its locator */
  EXEC SQL ASSOCIATE LOCATORS (:rs_loc1)
        WITH PROCEDURE SYSPROC.ADMIN_JOB_FETCH;

  /* Associate a cursor with the result set */
  EXEC SQL ALLOCATE C1 CURSOR FOR RESULT SET :rs_loc1;

  /* Perform fetches using C1 to retrieve all rows from the */
  /* result set */
  EXEC SQL FETCH C1 INTO :rownum, :text;
  while(SQLCODE==0)
  {
    EXEC SQL FETCH C1 INTO :rownum, :text;
  }

  EXEC SQL CLOSE C1;
}

return(retcd);
}

```

Output

This stored procedure returns the following output parameters, which are described in “[Option descriptions](#)” on page 792:

- *return-code*
- *message*

In addition to the preceding output, the stored procedure returns one result set that contains the data from the JES-managed SYSOUT data set that belong to the job ID specified in the input parameter *job-ID*.

The following table shows the format of the result set returned in the created global temporary table SYSIBM.JES_SYSOUT:

Table 142. Result set row for ADMIN_JOB_FETCH result set

Column name	Data type	Contents
ROWNUM	INTEGER	Sequence number of the table row
TEXT	VARCHAR(4096)	A record in the SYSOUT data set

GUPI

ADMIN_JOB_QUERY stored procedure

The SYSPROC.ADMIN_JOB_QUERY stored procedure displays the status and completion information about a job.

Environment

GUPI

The load module for ADMIN_JOB_QUERY, DSNADMJQ, must reside in an APF-authorized library. ADMIN_JOB_QUERY runs in a WLM-established stored procedure address space, and all libraries in this WLM procedure STEPLIB DD concatenation must be APF-authorized.

The load module for ADMIN_JOB_QUERY, DSNADMJQ, must be program controlled if the BPX.DAEMON.HFCTL FACILITY class profile has not been set up. For information on how to define DSNADMJQ to program control, see installation job DSNTIJRA.

Authorization

To execute the CALL statement, the owner of the package or plan that contains the CALL statement must have one or more of the following privileges:

- The EXECUTE privilege on the ADMIN_JOB_QUERY stored procedure
- Ownership of the stored procedure
- SYSADM authority

Syntax

The following syntax diagram shows the SQL CALL statement for invoking this stored procedure:

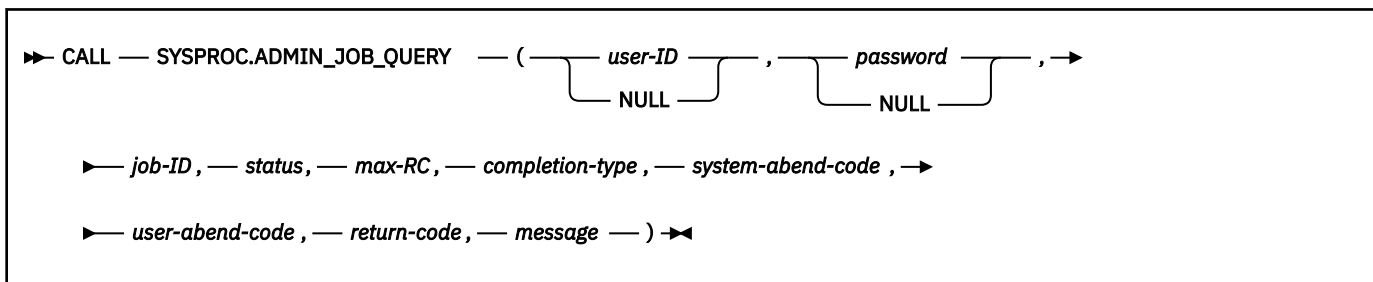

Option descriptions

user-ID

Specifies the user ID under which the job is queried.

If *user-ID* is NULL, *password* must also be NULL. If the *user-ID* and *password* values are NULL, the login process uses the primary authorization ID of the process.

You can specify NULL for this parameter in the following circumstances:

- The authorization ID that is associated with the stored procedure address space has daemon authority.
- The authorization ID that is associated with the stored procedure address space does not have daemon authority but is authorized to the BPX.SRV.*userid* SURROGAT class profile, where *userid* is the authorization ID of the stored procedure. For more information about how the RACF security administrator can authorize the authorization ID that is associated with the stored procedure address space to a SURROGAT class profile, see [Defining servers to process users without passwords or password phrases](#).

Daemon authority is given to any superuser that is permitted to the BPX.DAEMON FACILITY class profile. If the BPX.DAEMON FACILITY class profile is not defined, all superusers have daemon authority.

This is an input parameter of type VARCHAR(128).

password

Specifies the password associated with the input parameter *user-ID*.

The value of *password* is passed to the stored procedure as part of payload, and is not encrypted. It is not stored in dynamic cache when parameter markers are used.

If *password* is NULL, *user-ID* must also be NULL. If the *user-ID* and *password* values are NULL, the login process uses the primary authorization ID of the process.

You can specify NULL for this parameter in the following circumstances:

- The authorization ID that is associated with the stored procedure address space has daemon authority.

- The authorization ID that is associated with the stored procedure address space does not have daemon authority but is authorized to the BPX.SRV.userid SURROGAT class profile, where *userid* is the authorization ID of the stored procedure.

This is an input parameter of type VARCHAR(100).

job-ID

Specifies the job ID of the job being queried. Acceptable formats are:

- *Jnnnnnnn*
- *JOBnnnnn*

where *n* is a digit in the range 0–9. For example: JOB01035

Both *Jnnnnnnn* and *JOBnnnnn* must be exactly 8 characters in length.

This is an input parameter of type CHAR(8) and cannot be null.

status

Identifies the current status of the job. Possible values are:

- 1** Job received, but not yet run (INPUT).
- 2** Job running (ACTIVE).
- 3** Job finished and has output to be printed or retrieved (OUTPUT).
- 4** Job not found.
- 5** Job in an unknown phase.

This is an output parameter of type INTEGER.

max-RC

Provides the job completion code.

This is an output parameter of type INTEGER.

completion-type

Identifies the job's completion type. Possible values are:

- 0** No completion information is available.
- 1** Job ended normally.
- 2** Job ended by completion code.
- 3** Job had a JCL error.
- 4** Job was canceled.
- 5** Job terminated abnormally.
- 6** Converter terminated abnormally while processing the job.
- 7** Job failed security checks.
- 8** Job failed in end-of-memory .

The *completion-type* information is the last six bits in the field STTRMXRC of the IAZSSST mapping macro. This information is returned via SSI 80. For additional information, see the discussion of the SSST macro in *z/OS MVS Data Areas*.

This is an output parameter of type INTEGER.

system-abend-code

Returns the system abend code if an abnormal termination occurs.

This is an output parameter of type INTEGER.

user-abend-code

Returns the user abend code if an abnormal termination occurs.

This is an output parameter of type INTEGER.

return-code

Provides the return code from the stored procedure. Possible values are:

0

The call completed successfully.

4

The job was not found, or the job status is unknown.

12

The call did not complete successfully. The *message* output parameter contains messages describing the error.

This is an output parameter of type INTEGER.

message

Contains messages describing the error encountered by the stored procedure. If no error occurred, then no message is returned.

This is an output parameter of type VARCHAR(1331).

Example

The following C language sample shows how to invoke ADMIN_JOB_QUERY:

```
#include <stdio.h>
#include <stdlib.h>
#include <string.h>

/***** DB2 SQL Communication Area *****/
EXEC SQL INCLUDE SQLCA;

int main( int argc, char *argv[] ) /* Argument count and list */
{
    /***** DB2 Host Variables *****/
    EXEC SQL BEGIN DECLARE SECTION;

    /* SYSPROC.ADMIN_JOB_QUERY parameters */
    char      userid[129];          /* User ID */
    short int ind_userid;          /* Indicator variable */
    char      password[101];       /* Password */
    short int ind_password;        /* Indicator variable */
    char      jobid[9];            /* Job ID */
    short int ind_jobid;           /* Indicator variable */
    long int  stat;                /* Job status */
    short int ind_stat;            /* Indicator variable */
    long int  maxrc;               /* Job maxcc */
    short int ind_maxrc;           /* Indicator variable */
    long int  comptype;            /* Job completion type */
    short int ind_comptype;        /* Indicator variable */
    long int  sabndcd;             /* System abend code */
    short int ind_sabndcd;         /* Indicator variable */
    long int  uabndcd;             /* User abend code */
    short int ind_uabndcd;         /* Indicator variable */
    long int  retcd;               /* Return code */
    short int ind_retcd;           /* Indicator variable */
    char      errmsg[1332];        /* Error message */
    short int ind_errmsg;          /* Indicator variable */
}
```

```

EXEC SQL END DECLARE SECTION;

/*****
/* Assign values to input parameters to query the status and      */
/* completion code of a job                                     */
/* Set the indicator variables to 0 for non-null input parameters */
*****/
strcpy(userid, "USRT001");
ind_userid = 0;
strcpy(password, "N1CETEST");
ind_password = 0;
strcpy(jobid, "JOB00111");
ind_jobid = 0;

/*****
/* Call stored procedure SYSPROC.ADMIN_JOB_QUERY                */
*****/
EXEC SQL CALL SYSPROC.ADMIN_JOB_QUERY
          (:userid      :ind_userid,
          :password    :ind_password,
          :jobid       :ind_jobid,
          :stat        :ind_stat,
          :maxrc       :ind_maxrc,
          :comptype    :ind_comptype,
          :sabndcd     :ind_sabndcd,
          :uabndcd     :ind_uabndcd,
          :retcd       :ind_retcd,
          :errmsg       :ind_errmsg);

return(retcd);
}

```

Output

This stored procedure returns the following output parameters, which are described in [“Option descriptions”](#) on page 795:

- *status*
- *max-RC*
- *completion-type*
- *system-abend-code*
- *user-abend-code*
- *return-code*
- *message*



ADMIN_JOB_SUBMIT stored procedure

The SYSPROC.ADMIN_JOB_SUBMIT stored procedure submits a job to a JES2 or JES3 system.

Environment



ADMIN_JOB_SUBMIT runs in a WLM-established stored procedure address space.

The load module for ADMIN_JOB_SUBMIT, DSNADMJS, must be program controlled if the BPX.DAEMON.HFCTL FACILITY class profile has not been set up. For information on how to define DSNADMJS to program control, see installation job DSNTIJRA.

Authorization

To execute the CALL statement, the owner of the package or plan that contains the CALL statement must have one or more of the following privileges on each package that the stored procedure uses:

- The EXECUTE privilege on the package for DSNADMJS
- Ownership of the package
- PACKADM authority for the package collection
- SYSADM authority

Syntax

The following syntax diagram shows the SQL CALL statement for invoking this stored procedure:

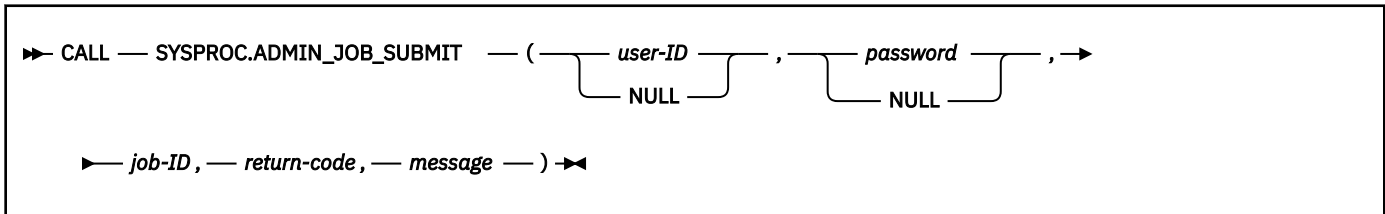

Option descriptions

user-ID

Specifies the user ID under which the job is submitted.

If *user-ID* is NULL, *password* must also be NULL. If the *user-ID* and *password* values are NULL, the login process uses the primary authorization ID of the process.

You can specify NULL for this parameter in the following circumstances:

- The authorization ID that is associated with the stored procedure address space has daemon authority.
- The authorization ID that is associated with the stored procedure address space does not have daemon authority but is authorized to the BPX.SRV.*userid* SURROGAT class profile, where *userid* is the authorization ID of the stored procedure. For more information about how the RACF security administrator can authorize the authorization ID that is associated with the stored procedure address space to a SURROGAT class profile, see [Defining servers to process users without passwords or password phrases](#).

Daemon authority is given to any superuser that is permitted to the BPX.DAEMON FACILITY class profile. If the BPX.DAEMON FACILITY class profile is not defined, all superusers have daemon authority.

This is an input parameter of type VARCHAR(128).

password

Specifies the password associated with the input parameter *user-ID*.

The value of *password* is passed to the stored procedure as part of payload and is not encrypted. It is not stored in dynamic cache when parameter markers are used.

If *password* is NULL, *user-ID* must also be NULL. If the *user-ID* and *password* values are NULL, the login process uses the primary authorization ID of the process.

You can specify NULL for this parameter in the following circumstances:

- The authorization ID that is associated with the stored procedure address space has daemon authority.
- The authorization ID that is associated with the stored procedure address space does not have daemon authority but is authorized to the BPX.SRV.*userid* SURROGAT class profile, where *userid* is the authorization ID of the stored procedure.

This is an input parameter of type VARCHAR(100).

job-ID

Identifies the JES2 or JES3 job ID of the submitted job.

This is an output parameter of type CHAR(8).

return-code

Provides the return code from the stored procedure. Possible values are:

0

The call completed successfully.

12

The call did not complete successfully. The *message* output parameter contains messages describing the error.

This is an output parameter of type INTEGER.

message

Contains messages describing the error encountered by the stored procedure. If no error occurred, then no message is returned.

The first messages in this area are generated by the stored procedure. Messages that are generated by Db2 might follow the first messages.

This is an output parameter of type VARCHAR(1331).

Additional input

In addition to the input parameters, the stored procedure submits the job's JCL from the created global temporary table SYSIBM.JOB_JCL for execution.

The following table shows the format of the created global temporary table SYSIBM.JOB_JCL:

Table 143. Additional input for the ADMIN_JOB_SUBMIT stored procedure

Column name	Data type	Contents
ROWNUM	INTEGER	Sequence number of the table row, from 1 to <i>n</i>
STMT	VARCHAR(80)	A JCL statement

Example

The following C language sample shows how to invoke ADMIN_JOB_SUBMIT:

```
#include <stdio.h>
#include <stdlib.h>
#include <string.h>

/***** DB2 SQL Communication Area *****/
EXEC SQL INCLUDE SQLCA;

int main( int argc, char *argv[] ) /* Argument count and list */
{
  /***** DB2 Host Variables *****/
  EXEC SQL BEGIN DECLARE SECTION;

  /* SYSPROC.ADMIN_JOB_SUBMIT parameters */
  char      userid[129];          /* User ID */
  short int ind_userid;          /* Indicator variable */
  char      password[101];       /* Password */
  short int ind_password;       /* Indicator variable */
  char      jobid[9];            /* Job ID */
  short int ind_jobid;          /* Indicator variable */
  long int  retcd;               /* Return code */
  short int ind_retcd;          /* Indicator variable */
  char      errmsg[1332];       /* Error message */
  short int ind_errmsg;         /* Indicator variable */

  /* Temporary table SYSIBM.JOB_JCL columns */
  long int  rownum;              /* Sequence number of the */
  /* table row */
  char      stmt[81];            /* JCL statement */
  EXEC SQL END DECLARE SECTION;
```

```

/*****
/* Create the JCL job to be submitted for execution */
/*****
char jclstmt[12][50] = {
  "//IEBCOPY JOB ,CLASS=K,MSGCLASS=H,MSGLEVEL=(1,1)",
  "//STEP010 EXEC PGM=IEBCOPY",
  "//SYSPRINT DD SYSOUT=*",
  "//SYSUT3 DD SPACE=(TRK,(1,1)),UNIT=SYSDA",
  "//SYSUT4 DD SPACE=(TRK,(1,1)),UNIT=SYSDA",
  "/*",
  "//DDI1 DD DSN=USER.DEV.LOADLIB1,DISP=SHR",
  "//DD01 DD DSN=USER.DEV.LOADLIB2,DISP=SHR",
  "//SYSIN DD *",
  " COPY OUTDD=DD01,INDD=DDI1",
  "/*",
  "/*",
  "/*",
  };
int i = 0;                               /* loop counter */

/*****
/* Assign values to input parameters */
/* Set the indicator variables to 0 for non-null input parameters */
/*****
strcpy(userid, "USRT001");
ind_userid = 0;
strcpy(password, "N1CETEST");
ind_password = 0;

/*****
/* Clear temporary table SYSIBM.JOB_JCL */
/*****
EXEC SQL DELETE FROM SYSIBM.JOB_JCL;

/*****
/* Insert the JCL job into the temporary table SYSIBM.JOB_JCL */
/*****
for (i = 0; i < 12; i++)
{
  rownum = i+1;
  strcpy(stmt, jclstmt[i]);
  EXEC SQL INSERT INTO SYSIBM.JOB_JCL
    ( ROWNUM, STMT)
    VALUES (:rownum, :stmt);
};

/*****
/* Call stored procedure SYSPROC.ADMIN_JOB_SUBMIT */
/*****
EXEC SQL CALL SYSPROC.ADMIN_JOB_SUBMIT
          (:userid      :ind_userid,
          :password    :ind_password,
          :jobid       :ind_jobid,
          :retcd       :ind_retcd,
          :errmsg       :ind_errmsg);

return(retcd);
}

```

Output

This stored procedure returns the following output parameters, which are described in [“Option descriptions”](#) on page 799:

- *job-ID*
- *return-code*
- *message*



ADMIN_TASK_ADD stored procedure

The SYSPROC.ADMIN_TASK_ADD stored procedure adds a task to the task list of the administrative task scheduler.

GUI

Environment

ADMIN_TASK_ADD runs in a WLM-established stored procedure address space and uses the Resource Recovery Services attachment facility to connect to Db2.

Authorization

Anyone who can execute this Db2 stored procedure is allowed to add a task.

The user who calls this stored procedure must have MONITOR1 privilege.

Syntax

The following syntax diagram shows the SQL CALL statement for invoking this stored procedure:

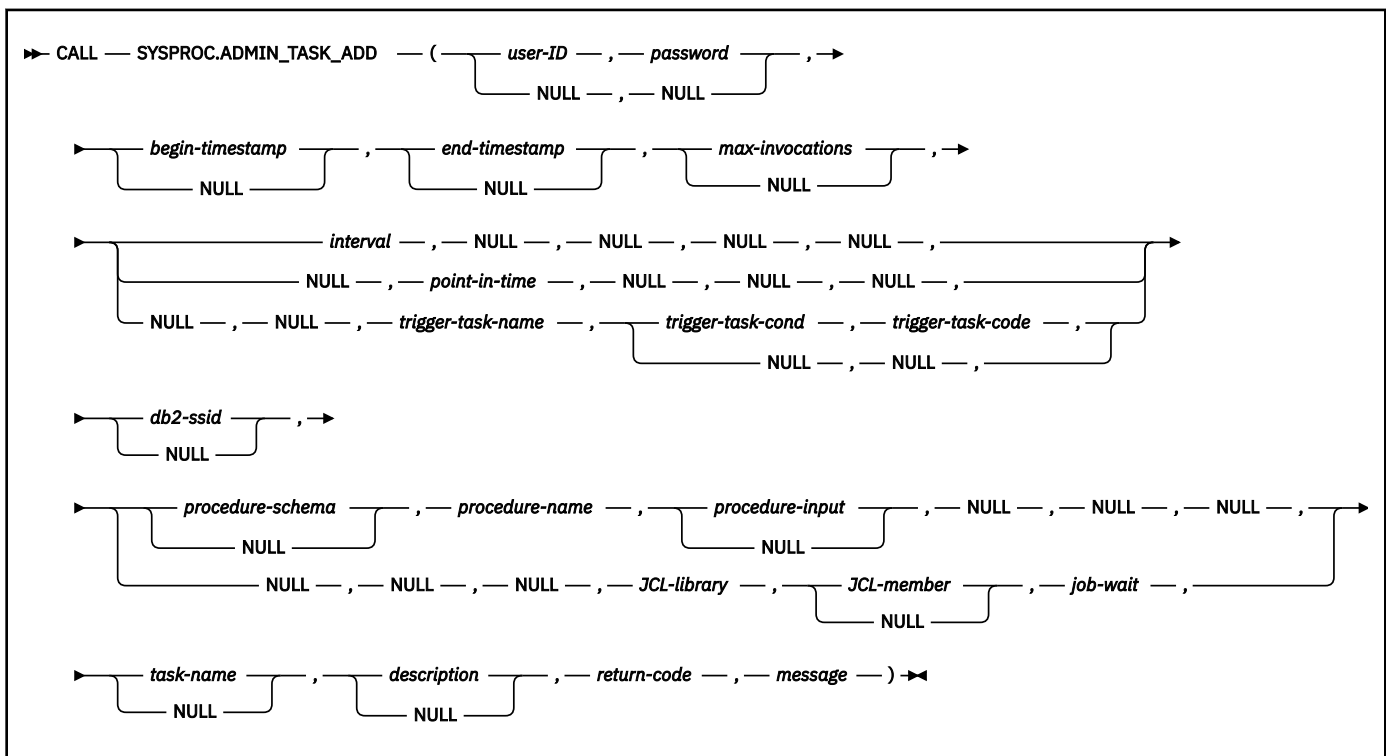

Option descriptions

user-ID

Specifies the user ID under which the task execution is performed.

If this parameter is set to NULL, task execution is performed with the default authorization ID associated with the administrative task scheduler instead.

This is an input parameter of type VARCHAR(128).

password

Specifies the password associated with the input parameter *user-ID*.

The value of *password* is passed to the stored procedure as part of payload, and is not encrypted. It is not stored in dynamic cache when parameter markers are used.

Recommendation: Have the application that invokes this stored procedure pass an encrypted single-use password called a *passticket*.

This is an input parameter of type VARCHAR(24). This parameter is NULL only when *user-ID* is set to NULL, and must be NULL when *user-ID* is NULL.

begin-timestamp

Specifies when a task can first begin execution. When task execution begins depends on how this and other parameters are set:

Non-null value for *begin-timestamp*

At *begin-timestamp*

The task execution begins at *begin-timestamp* if *point-in-time* and *trigger-task-name* are NULL.

Next point in time defined at or after *begin-timestamp*

The task execution begins at the next point in time defined at or after *begin-timestamp* if *point-in-time* is non-null.

When *trigger-task-name* completes at or after *begin-timestamp*

The task execution begins the next time that *trigger-task-name* completes at or after *begin-timestamp*.

Null value for *begin-timestamp*

Immediately

The task execution begins immediately if *point-in-time* and *trigger-task-name* are NULL.

Next point in time defined

The task execution begins at the next point in time defined if *point-in-time* is non-null.

When *trigger-task-name* completes

The task execution begins the next time that *trigger-task-name* completes.

The value of this parameter cannot be in the past, and it cannot be later than *end-timestamp*.

This is an input parameter of type TIMESTAMP.

end-timestamp

Specifies when a task can last begin execution. If this parameter is set to NULL, then the task can continue to execute as scheduled indefinitely.

The value of this parameter cannot be in the past, and it cannot be earlier than *begin-timestamp*.

This is an input parameter of type TIMESTAMP.

max-invocations

Specifies the maximum number of executions allowed for a task. This value applies to all schedules: triggered by events, recurring by time interval, and recurring by points in time. If this parameter is set to NULL, then there is no limit to the number of times this task can execute.

For tasks that execute only one time, *max-invocations* must be set to 1 and *interval*, *point-in-time* and *trigger-task-name* must be NULL.

If both *end-timestamp* and *max-invocations* are specified, the first limit reached takes precedence. That is, if *end-timestamp* is reached, even though the number of task executions so far has not reached *max-invocations*, the task will not be executed again. If *max-invocations* have occurred, the task will not be executed again even if *end-timestamp* is not reached.

This is an input parameter of type INTEGER.

interval

Defines a duration in minutes between two executions of a repetitive regular task. The first execution occurs at *begin-timestamp*. If this parameter is set to NULL, the task is not regularly executed. If this parameter contains a non-null value, the parameters *point-in-time* and *trigger-task-name* must be set to NULL.

This is an input parameter of type INTEGER.

point-in-time

Defines one or more points in time when a task is executed. If this parameter is set to NULL, the task is not scheduled at fixed points in time. If this parameter contains a non-null value, the parameters *interval* and *trigger-task-name* must be set to NULL.

The *point-in-time* string uses the UNIX cron format. The format contains the following pieces of information separated by blanks: given minute or minutes, given hour or hours, given day or days of the month, given month or months of the year, and given day or days of the week. For each part, you can specify one or several values, ranges, and so forth.

This is an input parameter of type VARCHAR(400).

trigger-task-name

Specifies the name of the task which, when its execution is complete, will trigger the execution of this task.

Task names of DB2START and DB2STOP are reserved for Db2 stop and start events respectively. Those events are handled by the scheduler associated with the Db2 subsystem that is starting or stopping.

If this parameter is set to NULL, the execution of this task will not be triggered by another task. If this parameter contains a non-null value, the parameters *interval* and *point-in-time* must be set to NULL.

This is an input parameter of type VARCHAR(128).

trigger-task-cond

Specifies the type of comparison to be made to the return code after the execution of task *trigger-task-name*. Possible values are:

GT

Greater than

GE

Greater than or equal to

EQ

Equal to

LT

Less than

LE

Less than or equal to

NE

Not equal to

If this parameter is set to NULL, the task execution is triggered without considering the return code of task *trigger-task-name*. This parameter must be set to NULL if *trigger-task-name* is set to NULL or is either DB2START or DB2STOP.

This is an input parameter of type CHAR(2).

trigger-task-code

Specifies the return code from executing *trigger-task-name*.

If the execution of this task is triggered by a stored procedure, *trigger-task-code* contains the SQLCODE that must be returned by the triggering stored procedure in order for this task to execute.

If the execution of this task is triggered by a JCL job, *trigger-task-code* contains the MAXRC that must be returned by the triggering job in order for this task to execute.

To find out what the MAXRC or SQLCODE of a task is after execution, invoke the user-defined function DSNADM.ADMIN_TASK_STATUS returns these information in the columns MAXRC and SQLCODE.

The following restrictions apply to the value of *trigger-task-code*:

- If *trigger-task-cond* is null, then *trigger-task-code* must also be null.
- If *trigger-task-cond* is non-null, then *trigger-task-code* must also be non-null.

If *trigger-task-cond* and *trigger-task-code* are not null, they are used to test the return code from executing *trigger-task-name* to determine whether to execute this task or not.

For example, if *trigger-task-cond* is set to "GE" and *trigger-task-code* is set to "8", then this task will execute if and only if the previous execution of *trigger-task-name* returned a MAXRC (for a JCL job) or an SQLCODE (for a stored procedure) greater than or equal to 8.

This is an input parameter of type INTEGER.

db2-ssid

Specifies the Db2 subsystem ID whose associated scheduler should execute the task.

This parameter is used in a data sharing environment where, for example different Db2 members have different configurations and executing the task relies on a certain environment. However, specifying a value in *db2-ssid* will prevent schedulers of other members to execute the task, so that the task can only be executed as long as the scheduler of *db2-ssid* is running.

For a task being triggered by a Db2 start or Db2 stop event in *trigger-task-name*, specifying a value in *db2-ssid* will let the task be executed only when the named subsystem is starting and stopping. If no value is given, each member that starts or stops will trigger a local execution of the task, provided that the executions are serialized.

If this parameter is set to NULL, any scheduler can execute the task.

This is an input parameter of type VARCHAR(4).

procedure-schema

Specifies the schema of the Db2 stored procedure this task will execute. If this parameter is set to NULL, Db2 uses a default schema. This parameter must be set to NULL if *procedure-name* is set to NULL.

This is an input parameter of type VARCHAR(128).

procedure-name

Specifies the name of the Db2 stored procedure this task will execute. If this parameter is set to NULL, no stored procedure will be called. In this case, a JCL job must be specified.

This is an input parameter of type VARCHAR(128).

procedure-input

Specifies the input parameters of the Db2 stored procedure this task will execute. This parameter must contain a Db2 SELECT statement that returns one row of data. The returned values will be passed as parameter to the stored procedure.

If this parameter is set to NULL, no parameters are passed to the stored procedure. This parameter must be set to NULL when *procedure-name* is set to NULL.

This is an input parameter of type VARCHAR(4096).

JCL-library

Specifies the name of the data set where the JCL job to be executed is saved.

If this parameter is set to NULL, no JCL job will be executed. In this case, a stored procedure must be specified.

This is an input parameter of type VARCHAR(44).

JCL-member

Specifies the name of the library member where JCL job to be executed is saved.

If this parameter is set to NULL, the data set specified in *JCL-library* must be sequential and contain the JCL job to be executed. This parameter must be set to NULL if *JCL-library* is set to NULL.

This is an input parameter of type VARCHAR(8).

job-wait

Specifies whether the job can be executed synchronously or not. This parameter can only be set to NULL if *JCL-library* is set to NULL. Otherwise, it must be one of the following values:

NO

Specifies asynchronous execution. The sub-thread does not wait until the job completes execution and returns immediately after the job submission. The task execution status is set to the submission status, the result of the job execution itself is unavailable.

YES

Specifies synchronous execution. The sub-thread simulates a synchronous execution of the JCL job. It waits until the job execution completes, gets the job status from the JES reader, and fills in the last execution status of the task.

PURGE

Specifies that the job status in z/OS is purged. The sub-thread purges the job output from the JES reader after execution. Execution is the same as when *job-wait* is YES.

This is an input parameter of type VARCHAR(8).

task-name

Specifies a unique name assigned to the task.

A unique task name is returned when the task is created with a NULL *task-name* value. This name is of the format "TASK_ID_xxxx" where xxxx is 0001 for the first task named, 0002 for the second task, and so forth.

The following task names are reserved and cannot be given as the value of *task-name*:

- Names starting with "TASK_ID_"
- DB2START
- DB2STOP

This is an input-output parameter of type VARCHAR(128).

description

Specifies a description assigned to the task.

This is an input parameter of type VARCHAR(128).

return-code

Provides the return code from the stored procedure. Possible values are:

0

The call completed successfully.

12

The call did not complete successfully. The *message* output parameter contains messages describing the error.

This is an output parameter of type INTEGER.

message

Contains messages describing the error encountered by the stored procedure. The first messages in this area, if any, are generated by the stored procedure. Messages that are generated by Db2 might follow the first messages.

This is an output parameter of type VARCHAR(1331).

Example

The following Java sample shows how to invoke ADMIN_TASK_ADD:

```
import java.sql.CallableStatement;
import java.sql.Connection;
import java.sql.DriverManager;
import java.sql.Statement;
import java.sql.Timestamp;
```

```

import java.sql.Types;

Connection con = DriverManager.getConnection
("jdbc:db2://myserver:myport/mydatabase", "myuser", "mypassword");
CallableStatement callStmt = con.prepareCall
("CALL SYSPROC.ADMIN_TASK_ADD("
+ "? , ? , ? , ? , ? , ? , ? , ? , ? , ? , ? , ? , ? , ? , ? , ? , ? , ? , ? , ? )");
// provide the authid
callStmt.setString(1, "myexecuser");
// provide the password
callStmt.setString(2, "myexecpwd");
// set the start time to now
callStmt.setNull(3, Types.TIMESTAMP);
// no end time
callStmt.setNull(4, Types.TIMESTAMP);
// set the max invocation
callStmt.setInt(5, 1);
// This is a non recurrent task
callStmt.setNull(6, Types.INTEGER);
callStmt.setNull(7, Types.VARCHAR);
callStmt.setNull(8, Types.VARCHAR);
callStmt.setNull(9, Types.CHAR);
callStmt.setNull(10, Types.INTEGER);
callStmt.setNull(11, Types.VARCHAR);
// provide the stored procedure schema
callStmt.setString(12, "MYSHEMA");
// provide the name of the stored procedure to be executed
callStmt.setString(13, "MYPROC");
// provide the stored procedure input parameter
callStmt.setString(14, "SELECT 1 FROM SYSIBM.SYSDUMMY1");
// This is not a JCL job
callStmt.setNull(15, Types.VARCHAR);
callStmt.setNull(16, Types.VARCHAR);
callStmt.setNull(17, Types.VARCHAR);
// add a new task with task name mytask
callStmt.setString(18, "mytask");
callStmt.registerOutParameter(18, Types.VARCHAR);
// provide the task description
callStmt.setString(19, "MY DESCRIPTION");
// register output parameters for error management
callStmt.registerOutParameter(20, Types.INTEGER);
callStmt.registerOutParameter(21, Types.VARCHAR);
// execute the statement
callStmt.execute();
// manage the return code
if ( callStmt.getInt(20) == 0 )
{
    System.out.print("\nSuccessfully added task " + callStmt.getString(18));
}
else
{
    System.out.print("\nError code and message are: "
+ callStmt.getInt(20) + "/" + callStmt.getString(21));
}
}

```

Output

The output of this stored procedure is the task name, *task-name* and the following output parameters, which are described in [“Option descriptions” on page 802](#):

- *return-code*
- *message*



Related concepts

[Scheduled execution of a JCL job \(Db2 Administration Guide\)](#)

Related tasks

[Adding a task \(Db2 Administration Guide\)](#)

ADMIN_TASK_CANCEL stored procedure

The ADMIN_TASK_CANCEL stored procedure attempts to stop the execution of a task that is currently running.

For a task that is running, the stored procedure cancels the Db2 thread or the JES job that the task runs in, and issues a return code of 0 (zero). If the task is not running or if cancellation of the task cannot be initiated, the stored procedure issues a return code of 12.

Not all tasks can be canceled as requested. Only the administrative task scheduler that currently executes the task can cancel a JCL task or a stored procedure task. Call the ADMIN_TASK_CANCEL stored procedure on the Db2 subsystem that is specified in the DB2_SSID column of the task status.

GUI

Environment

ADMIN_TASK_CANCEL runs in a WLM-established stored procedure address space and uses the Resource Recovery Services attachment facility to connect to Db2.

Authorization

To call this stored procedure, you must have MONITOR1 privilege.

Anyone with SYSOPR, SYSCTRL, or SYSADM authority can call this stored procedure on any task. Anyone who has EXECUTE authority on this stored procedure can call it on tasks that they added. If you try to cancel the execution of a task that was added by a different user, an error is returned in the output.

The task is canceled under the authorization context of the user that currently calls the ADMIN_TASK_CANCEL stored procedure, as defined in CURRENT SQLID. To cancel a stored procedure task, you must have authority to call the Db2 command **CANCEL THREAD**. To cancel a JCL task, you must have UPDATE authority in RACF on the resource MVS.CANCEL.JOB.jobname.

Syntax

The following syntax diagram shows the SQL CALL statement for invoking this stored procedure:

```
►► CALL — ADMIN_TASK_CANCEL — ( — task-name — , — return-code — , — message — ) ►►
```

Option descriptions

task-name

Specifies the unique name of the task whose execution you want to cancel. This is an input parameter of type VARCHAR(128).

return-code

Provides the return code from the stored procedure. Possible values are:

0

The call completed successfully.

12

The call did not complete successfully. The *message* output parameter contains messages describing the error.

This is an output parameter of type INTEGER.

message

Contains messages describing the error encountered by the stored procedure. The first messages in this area, if any, are generated by the stored procedure. Messages that are generated by Db2 might follow the stored procedure messages.

This is an output parameter of type VARCHAR(1331).

Output

This stored procedure has the following output parameters, which are described in [“Option descriptions”](#) on page 808:

- *return-code*
- *message*



Related tasks

[Stopping the execution of a task \(Db2 Administration Guide\)](#)

ADMIN_TASK_REMOVE stored procedure

The SYSPROC.ADMIN_TASK_REMOVE stored procedure removes a task from the task list of the administrative task scheduler.

If the task is running, the task continues to execute until completion and is not removed from the task list. If other tasks depend on the execution of the task that is to be removed, the task is not removed from the task list of the administrative task scheduler.



Environment

See the recommended environment in installation job DSNTIJRA.

Authorization

Users with SYSOPR, SYSCTRL, or SYSADM authority can remove any task. Other users who have EXECUTE authority on this stored procedure can remove tasks that they added. Attempting to remove a task that was added by a different user returns an error in the output.

The user who calls this stored procedure must have MONITOR1 privilege.

Syntax

The following syntax diagram shows the SQL CALL statement for invoking this stored procedure:

```
►► CALL — SYSPROC.ADMIN_TASK_REMOVE — ( — task-name, — return-code, — message — ) ►►
```

Option descriptions

task-name

Specifies the name of the task to be removed from the task list of the administrative task scheduler.

This is an input parameter of type VARCHAR(128) and cannot be null.

return-code

Provides the return code from the stored procedure. Possible values are:

0

The call completed successfully.

12

The call did not complete successfully. The *message* output parameter contains messages describing the error.

This is an output parameter of type INTEGER.

message

Contains messages describing the error encountered by the stored procedure. The first messages in this area, if any, are generated by the stored procedure. Messages that are generated by Db2 might follow the stored procedure messages.

This is an output parameter of type VARCHAR(1331).

Example

The following Java sample shows how to invoke ADMIN_TASK_REMOVE:

```
import java.sql.CallableStatement;
import java.sql.Connection;
import java.sql.DriverManager;
import java.sql.Statement;
import java.sql.Timestamp;
import java.sql.Types;

Connection con =
    DriverManager.getConnection("jdbc:db2://myserver:myport/mydatabase",
        "myuser", "mypassword");
CallableStatement callStmt =
    con.prepareCall("CALL SYSPROC.ADMIN_TASK_REMOVE(?, ?, ?)");
// provide the id of the task to be removed
callStmt.setString(1, "mytask");
// register output parameters for error management
callStmt.registerOutParameter(2, Types.INTEGER);
callStmt.registerOutParameter(3, Types.VARCHAR);
// execute the statement callStmt.execute();
// manage the return code
if ( callStmt.getInt(2) == 0 )
{
    System.out.print("\nSuccessfully removed task "
        + callStmt.getString(1));
}
else
{
    System.out.print("\nError code and message are: "
        + callStmt.getInt(2) + "/"
        + callStmt.getString(3));
}
```

Output

The output of this stored procedure includes the following output parameters, which are described in “Option descriptions” on page 809:

- *return-code*
- *message*



Related tasks

[Removing a scheduled task \(Db2 Administration Guide\)](#)

[Establishing subsystem security: DSNTIJRA \(optional\) \(Db2 Installation and Migration\)](#)

Related reference

[ADMIN_TASK_LIST table function](#)

The ADMIN_TASK_LIST function returns a table with one row for each of the tasks that are defined in the administrative task scheduler task list.

[ADMIN_TASK_STATUS table function](#)

The ADMIN_TASK_STATUS function returns a table with one row for each task that is defined in the administrative task scheduler task list. Each row indicates the status of the task for the last time it was run.

ADMIN_TASK_UPDATE stored procedure

The ADMIN_TASK_UPDATE stored procedure updates the schedule of a task that is in the task list for the administrative task scheduler. If the task that you want to update is running, the changes go into effect after the current execution finishes.

You must specify all of the parameters for the task that you want to modify the schedule for, even if those parameters have not changed since you created the task by using the ADMIN_TASK_ADD stored procedure.



Environment

ADMIN_TASK_UPDATE runs in a WLM-established stored procedure address space and uses the Resource Recovery Services attachment facility to connect to Db2.

Authorization

To call this stored procedure, you must have MONITOR1 privilege.

Anyone with SYSOPR, SYSCTRL, or SYSADM authority can update any task. Anyone who has EXECUTE authority on this stored procedure can update tasks that they added. If you try to update a task that was added by a different user, an error is returned in the output.

Syntax

The following syntax diagram shows the SQL CALL statement for invoking this stored procedure:

```
►► CALL — ADMIN_TASK_UPDATE — ( — task-name — , — description — , — begin_timestamp —►  
  
    ► — end_timestamp — , — max_invocations — , — interval — , — point-in-time — , —►  
  
    ► — trigger-task-name — , — trigger-task-cond — , — trigger-task-code — , — db2-ssid — , —►  
  
    ► — return-code — , — message — ) ►◄
```

Option descriptions

task-name

Specifies the unique name of the task that is to be updated in the task list of the administrative task scheduler. This is an input parameter of type VARCHAR(128).

description

Specifies a description that is assigned to the task. This is an input parameter of type VARCHAR(128).

begin_timestamp

An input parameter of type TIMESTAMP that specifies the earliest time a task can begin execution. The value of this argument cannot be in the past, and it cannot be later than *end_timestamp*.

When the execution of a task begins depends on how this parameter and other parameters are defined:

Non-null value for *begin_timestamp*

At *begin_timestamp*

The task execution begins at *begin_timestamp* if *point-in-time* and *trigger-task-name* are NULL.

Interval in minutes after the last execution of this task

The task execution begins at *begin-timestamp*.

Next point in time defined at or after *begin-timestamp*

The task execution begins at the next point in time that is defined at or after *begin-timestamp* if *point-in-time* is non-null.

When *trigger-task-name* completes after *begin-timestamp*

The task execution begins the next time that *trigger-task-name* completes or after *begin-timestamp*.

Null value for *begin-timestamp***Immediately**

The task execution begins immediately if *point-in-time* and *trigger-task-name* are NULL.

Interval in minutes after the last execution of this task

The task execution begins at *begin-timestamp*.

Next point in time defined

The task execution begins at the next point in time that is defined if *point-in-time* is non-null.

When *trigger-task-name* completes

The task execution begins the next time that *trigger-task-name* completes.

end-timestamp

An input parameter of type `TIMESTAMP` that specifies the latest time that a task can begin execution. The value of this argument cannot be in the past, and it cannot be earlier than *begin_timestamp*. If the argument is NULL, the task can continue to execute as scheduled indefinitely.

An executing task will not be interrupted at its *end_timestamp* value.

max-invocations

Specifies the maximum number of executions that are allowed for the modified task. This value applies to all scheduled executions, whether they be triggered by events, recurring by time interval, or recurring by points in time. This value includes the previous executions of the modified task.

If *max-invocations* is smaller than, or equal to the number of times that the task has already been executed, the task will not be executed again. To modify the task to run again, you must specify *max-invocations* as NULL, or as a value that is greater than the current number of times that the task has already been executed. In addition, if *max-invocations*, *interval*, *point-in-time*, and *trigger-task-name* are NULL, the task executes only one more time.

If this parameter is set to NULL, there is no limit to the number of times this task can execute. If both *end-timestamp* and *max-invocations* are specified, the first limit that is reached takes precedence. For example, if the value for *end-timestamp* is reached, the task will not be executed again, even if the number of task executions has not reached the value of *max-invocations*. Likewise, if the value for *max-invocations* is reached, the task will not be executed again, even if the value for *end-timestamp* is not reached.

This is an input parameter of type `INTEGER`.

interval

Defines a time duration between two executions of a repetitive regular task. The first execution occurs at *begin-timestamp*.

If this parameter is set to NULL, the task is not regularly executed. If this parameter contains a non-null value, you must set the *point-in-time* and *trigger-task-name* parameters to NULL.

This is an input parameter of type `INTEGER`.

point-in-time

Specifies one or more points in time when a task is executed. If this parameter is set to NULL, the task is not scheduled at fixed points in time. If this parameter contains a non-null value, the parameters *interval* and *trigger-task-name* must be set to NULL.

The *point-in-time* string uses the UNIX cron format. This format contains the following pieces of information separated by blank spaces:

- Given minute or minutes
- Given hour or hours
- Given day or days of the month
- Given month or months of the year
- Given day or days of the week

For each part, you can specify one or several values and ranges.

This is an input parameter of type VARCHAR(400).

trigger-task-name

Specifies the name of the task that, upon completion, will trigger the execution of this task. The task names DB2START and DB2STOP are reserved for Db2 startup and shutdown events. Those events are handled by the scheduler that is associated with the Db2 subsystem that is starting or stopping.

If this parameter is set to NULL, the execution of this task will not be triggered by another task. If this parameter contains a non-null value, the parameters *interval* and *point-in-time* must be NULL.

This is an input parameter of type VARCHAR(128).

trigger-task-cond

Specifies the type of comparison to be made to the return code after the execution of task *trigger-task-name*. Possible values are:

GT

Greater than

GE

Greater than or equal to

EQ

Equal to

LT

Less than

LE

Less than or equal to

NE

Not equal to

If this parameter is set to NULL, the task execution is triggered without considering the return code of task *trigger-task-name*. This parameter must be set to NULL if *trigger-task-name* is set to NULL or is either DB2START or DB2STOP.

This is an input parameter of type CHAR(2).

trigger-task-code

Specifies the return code from executing the task *trigger-task-name*.

If the execution of this task is triggered by a stored procedure, *trigger-task-code* contains the SQLCODE that must be returned by the triggering stored procedure in order for this task to execute.

If the execution of this task is triggered by a JCL job, *trigger-task-code* contains the MAXRC that must be returned by the triggering job in order for this task to execute.

To find out what the MAXRC or SQLCODE of a task is after execution, invoking the user-defined function DSNADM.ADMIN_TASK_STATUS returns this information in the columns MAXRC and SQLCODE.

The following restrictions apply to the value of *trigger-task-code*:

- If *trigger-task-cond* is NULL, then *trigger-task-code* must also be NULL.
- If *trigger-task-cond* is non-null, then *trigger-task-code* must also be non-null.

If *trigger-task-cond* and *trigger-task-code* are not set to NULL, they are used to test the return code from executing *trigger-task-name* to determine whether to execute this task. For example, if *trigger-task-cond* is set to "GE", and *trigger-task-code* is set to "8", then this task will execute only if the previous execution of *trigger-task-name* returned a MAXRC (for a JCL job) or an SQLCODE (for a stored procedure) that is greater than or equal to 8.

This is an input parameter of type INTEGER.

db2-ssid

Specifies the Db2 subsystem ID whose associated scheduler should execute the task.

This parameter is used in a data sharing environment, where different Db2 members have different configurations and executing the task relies on a certain environment. However, specifying a value in *db2-ssid* will prevent the administrative task schedulers of other members from executing the task. Therefore, the task can be executed only if the administrative task scheduler of *db2-ssid* is running.

For a task that is being triggered by a Db2 start or Db2 stop event in *trigger-task-name*, specifying a value in *db2-ssid* causes the task to be executed only when the named Db2 subsystem is starting or stopping. If no value is given, each member that starts or stops will trigger a local execution of the task, if the executions are serialized.

If this parameter is set to NULL, any administrative task scheduler can execute the task.

This is an input parameter of type VARCHAR(4).

return-code

Provides the return code from the stored procedure. Possible values are:

0

The call completed successfully.

12

The call did not complete successfully. The *message* output parameter contains messages describing the error.

This is an output parameter of type INTEGER.

message

Contains messages describing the error encountered by the stored procedure. The first messages in this area, if any, are generated by the stored procedure. Messages that are generated by Db2 might follow the stored procedure messages.

This is an output parameter of type VARCHAR(1331).

Output

This stored procedure has the following output parameters, which are described in [“Option descriptions” on page 811](#):

- *return-code*
- *message*

 **GUPI**

Related tasks

[Updating the schedule for a task \(Db2 Administration Guide\)](#)

ADMIN_UPDATE_SYSPARM stored procedure

The SYSPROC.ADMIN_UPDATE_SYSPARM stored procedure changes the value of one or more subsystem parameters which are located in one of these macros: DSN6SPRM, DSN6ARVP, DSN6LOGP, DSN6SYSP, DSN6FAC, and DSN6GRP.

 **GUPI**

ADMIN_UPDATE_SYSPARM builds a subsystem parameters load module and, if requested by the user, loads it into storage by issuing the Db2 command SET SYSPARM with the LOAD option. If all of the parameters that are modified cannot be updated online, SET SYSPARM LOAD is not run.

Environment

ADMIN_UPDATE_SYSPARM must run in a WLM-established stored procedure address space. At least one library in this WLM procedure STEPLIB DD concatenation must not be APF-authorized. TCB=1 is also required. By default, the SQL procedure processor (DSNTPSMP) and ADMIN_UPDATE_SYSPARM share the WLM environment.

Authorization

To issue the CALL statement, the owner of the package or plan that contains the CALL statement must have one or more of the following privileges:

- The EXECUTE privilege on the ADMIN_UPDATE_SYSPARM stored procedure
- Ownership of the stored procedure
- SYSADM authority

The ADMIN_UPDATE_SYSPARM stored procedure internally calls the following stored procedures:

- ADMIN_COMMAND_DB2, to issue the Db2 DISPLAY GROUP and SET SYSPARM commands
- ADMIN_INFO_SYSPARM, to obtain the current subsystem parameters settings

The owner of the package or plan that contains the CALL ADMIN_UPDATE_SYSPARM statement must also have the following authority and privilege:

- Authorization to run these stored procedures and issue the specified Db2 commands
- MONITOR1 privilege

The ADMIN_UPDATE_SYSPARM caller also needs authorization from an external security system, such as RACF, to complete the following tasks:

- Browse the data set that is pointed to by the ZPMDFLTS DD statement in the WLM startup procedure
- Update the library where the sample JCL that assembles and link-edits the new subsystem parameters load module will be saved
- Update the load module library where the new subsystem parameters load module will be saved

Syntax

The following syntax diagram shows the SQL CALL statement for running this stored procedure:

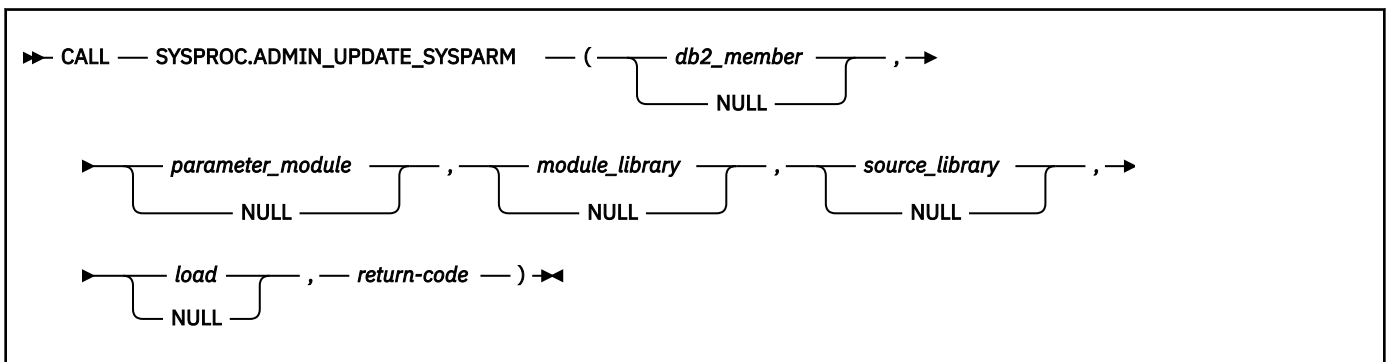

Option descriptions

db2_member

Specifies the name of a single data sharing group member on which the SET SYSPARM command with the LOAD option is to be run.

If this parameter is null, the SET SYSPARM command is run on the connected Db2 subsystem.

This is an input parameter of type VARCHAR(8).

In a data-sharing environment, some additional requirements apply. For example, if ADMIN_UPDATE_SYSPARM is run on member A to update a subsystem parameter setting on member B, the WLM environment for ADMIN_UPDATE_SYSPARM needs to be able to access the following resources:

- The library that is used to store the new subsystem parameters load module for member B
- The library that is used to store the sample JCL that assembles and link-edits the new subsystem parameters load module for member B.

parameter_module

Specifies the name of the subsystem parameters load module that has the new values assembled and linked into it.

If this parameter is null, the default is the last named subsystem parameters load module that was loaded into storage.

This is an input parameter of type VARCHAR(8).

module_library

Specifies the name of the library where the stored procedure saves the new subsystem parameters load module. If the *load* parameter is set to 'Y', this module library is also used to load the subsystem parameters load module.

If this parameter is null, the default is the SDSNEXIT_NAME library that is specified in the data set that is pointed to by the ZPMDFLTS DD statement in the WLM startup procedure.

This is an input parameter of type VARCHAR(44).

source_library

Specifies the name of the library where the stored procedure saves a sample JCL that assembles and link-edits the new subsystem parameters load module offline. This JCL contains the updated subsystem parameters.

This parameter must specify a partitioned data set (PDS) or a partitioned data set extended (PDSE) with record format (RECFM) F or FB and record length (LRECL) 80.

If this parameter is null, the default is the SRCLIB_NAME library that is specified in the data set that is pointed to by the ZPMDFLTS DD statement in the WLM startup procedure.

The name of the library member where the sample JCL is saved is the same as the library member name of the new subsystem parameters load module. This JCL is not used by ADMIN_UPDATE_SYSPARM to assemble and link-edit the subsystem parameters load module. This JCL is generated and saved so that it can be referenced for any subsequent subsystem parameter modification by the Db2 system programmer.

This is an input parameter of type VARCHAR(44).

load

Specifies whether to issue SET SYSPARM with the LOAD option to load the new subsystem parameters load module into storage. Possible values are:

Y

Issue SET SYSPARM with the LOAD option.

N

Do not issue SET SYSPARM with the LOAD option.

If this parameter is null, the default is 'N'.

If at least one modified subsystem parameter cannot be changed online or if SET SYSPARM synchronous support is not available (PM40501 is not installed), SET SYSPARM with the LOAD option is not issued even if *load* is set to 'Y'. Instead, a value of 4 is returned in the output parameter *return-code*.

This is an input parameter of type CHAR(1).

return-code

Provides the return code from the stored procedure. Possible values are:

0

The call completed successfully.

Message DSNA658I is written to the JES SYSLOG, but not to the JES job log of *ssnmMSTR*.

The following information is returned in the result table of the stored procedure:

- Message DSNA658I
- Assembler listing
- Link-edit listing
- SET SYSPARM command with LOAD option messages (if applicable)

4

- The stored procedure modified the value of at least one Db2 subsystem parameter. However, the stored procedure did not complete a required or requested action after the subsystem parameter values were changed:
 - The SET SYSPARM command with the LOAD option was not issued because of one of the following reasons:
 - At least one modified subsystem parameter cannot be changed online.
 - Synchronous processing of the SET SYSPARM command is not supported.
 - The stored procedure encountered an error while it was writing a DSNA658I message to the JES SYSLOG.

For more information, see message DSNA666I.

- The cleanup processing that occurs when the stored procedure completes successfully did not complete successfully because of one of the following reasons:
 - The backup of the library member that the stored procedure replaced with the new JCL that assembles and link-edits the new subsystem parameters load module was not deleted.
 - The backup of the library member that the stored procedure replaced with the new subsystem parameters load module was not deleted.

For more information, see message DSNA658I.

Message DSNA658I is written to the JES SYSLOG (if applicable), but not to the JES job log of *ssnmMSTR*.

The following information is returned in the result table of the stored procedure:

- Message DSNA658I
- Message DSNA666I or DSNA658I (depending on which reason caused *return_code* to be set to 4)
- Assembler listing
- Link-edit listing
- SET SYSPARM command with LOAD option messages (if applicable)

12

The call did not complete successfully.

Message DSNA669I is returned in the result set.

Objects that were replaced by the stored procedure are restored. For more information, see [“Backup copies” on page 819](#).

If the new subsystem parameters load module was loaded into storage, the stored procedure will reload the subsystem parameters load module that was loaded previously.

995

The call did not complete successfully because of a REXX programming violation.

Message DSNA669I is displayed in the WLM job log.

996

The call did not complete successfully because of one of the following global temporary table failures:

- The created global temporary table SYSIBM.UPDSYSPARM_MSG does not exist.
- The user does not have authority to use the created global temporary table SYSIBM.UPDSYSPARM_MSG.

Message DSNA669I is displayed in the WLM job.

997

The call did not complete successfully because of one of the following DSNREXX failures:

- The DSNREXX package was not found.
- Db2 cannot access a DSNREXX environment. Db2 REXX Language Support is not available.

Message DSNA669I is displayed in the WLM job log.

998

There was an error that occurred while the result set was being returned.

The result set is written to the WLM job log. However, the assembler listing and the link-edit listing are not written to the WLM job log unless the call did not complete successfully because the assembly failed or the link-edit failed. If the assembly failed, the assembler listing is written to the WLM job log. If the link-edit failed, the link-edit listing is written to the WLM job log.

This is an output parameter of type INTEGER.

ADMIN_UPDATE_SYSPARM input row

In addition to the input parameters, the stored procedure reads from the created global temporary table SYSIBM.SYSPARM_SETTINGS to retrieve the subsystem parameters to be modified. The following table shows the format of the created global temporary table SYSIBM.SYSPARM_SETTINGS:

Table 144. Format of the input subsystem parameters table

Column name	Data type	Contents
ROWNUM	INTEGER	A unique positive identifier for each row.
	NOT NULL	When you insert multiple rows, increment ROWNUM by 1, starting at 0 for every insert.

Table 144. Format of the input subsystem parameters table (continued)

Column name	Data type	Contents
MACRO	VARCHAR(8) NOT NULL	Macro that contains the Db2 subsystem parameter to be modified. Valid values are: DSN6SPRM, DSN6ARVP, DSN6LOGP, DSN6SYSP, DSN6FAC, and DSN6GRP.
PARAMETER	VARCHAR(40) NOT NULL	Name of the Db2 subsystem parameter to be modified.
NEW_VALUE	VARCHAR(2048) NOT NULL	New value of the Db2 subsystem parameter to be modified. This parameter is not validated by the stored procedure.

Backup copies

In the subsystem parameters load module library, if a member exists with the same name as the name of the new subsystem parameters load module, the stored procedure creates a backup copy of this member before it is replaced with the new subsystem parameters load module. Similarly, in the JCL source library, if a member exists with the same name as the name of the sample JCL that assembles and link-edits the new subsystem parameters load module, the stored procedure creates a backup copy of this member before it is replaced with the sample JCL. The backup copy is created in the same library where the member it replaced resides, and its name has the following format: *ssnmhhmm*, where:

ssnm

The *ssid* of the Db2 subsystem where the subsystem parameter changes are implemented.

hh

The hour the stored procedure started execution (00-23).

mm

The minute the stored procedure started execution (00-59).

When the stored procedure completes successfully, the backup copies are deleted.

When the stored procedure does not complete successfully, the stored procedure restores the replaced members to their state before the stored procedure was run by using their respective backup copies. If the stored procedure is unable to restore a member from the backup, the user must complete this task.

If a member exists with the same name as the backup copy the stored procedure is creating, the stored procedure terminates processing.

Example

The following C language example shows how to invoke ADMIN_UPDATE_SYSPARM.

```
#include <stdio.h>
#include <stdlib.h>
#include <string.h>
/***** DB2 SQL Communication Area *****/
EXEC SQL INCLUDE SQLCA;
int main( int argc, char *argv[] ) /* Argument count and list */
{
/***** DB2 Host Variables *****/
EXEC SQL BEGIN DECLARE SECTION;
/* SYSPROC.ADMIN_UPDATE_SYSPARM parameters */
char pmember[9]; /* Data sharing group member */
char pmodname[9]; /* Subsystem parameters load module */
char pmodlib[45]; /* Subsystem parameters load module library */
char psrclib[45]; /* Sample JCL library */
char pload[2]; /* Perform -SET SYSPARM with */
```

```

long int pretcd;          /* LOAD option          */
short int ind_pmember;   /* Return code          */
short int ind_pmodname;  /* Indicator variable   */
short int ind_pmodlib;   /* Indicator variable   */
short int ind_psrclib;   /* Indicator variable   */
short int ind_pload;     /* Indicator variable   */
short int ind_pretcd;    /* Indicator variable   */
/* Temporary table SYSIBM.SYSPARM_SETTINGS columns */
long int zrownum;        /* Sequence number of the
                        /* table row            */

char zmacro[9];          /* Macro containing the
                        /* subsystem parameter to be
                        /* modified              */

char zparam[41];         /* Name of the subsystem
                        /* parameter to be modified
                        /*                      */

char znew_value[2049];   /* New value of the subsystem
                        /* parameter to be modified
                        /*                      */

/* Result set locators
volatile SQL TYPE IS RESULT_SET_LOCATOR *rs_loc1;
/* Result set row
long int rownum;        /* Sequence number of the
                        /* table row            */

char type[13];           /* Type of information found
                        /* in corresponding TEXT col
                        /*                      */

char text[1332];         /* Message or listing
EXEC SQL END DECLARE SECTION;
/*****
/* Clear temporary table SYSIBM.SYSPARM_SETTINGS
/*****
EXEC SQL DELETE FROM SYSIBM.SYSPARM_SETTINGS;
/*****
/* Clear temporary table SYSIBM.UPDSYSPARM_MSG
/*****
EXEC SQL DELETE FROM SYSIBM.UPDSYSPARM_MSG;
/*****
/* Insert the subsystem parameters to be modified into the
/* created global temporary table SYSIBM.SYSPARM_SETTINGS
/*****
zrownum = 1;
strcpy(zmacro, "DSN6FAC");
strcpy(zparam, "IDTHTOIN");
strcpy(znew_value, "600");
EXEC SQL INSERT INTO SYSIBM.SYSPARM_SETTINGS
      ( ROWNUM, MACRO, PARAMETER, NEW_VALUE)
      VALUES (:zrownum, :zmacro, :zparam, :znew_value);
/*****
/* Set procedure input parameters
/*****
ind_pmember = -1;
ind_pmodname = -1;
ind_pmodlib = -1;
ind_psrclib = -1;
ind_pload = -1;
ind_pretcd = -1;

/*****
/* Call stored procedure SYSPROC.ADMIN_UPDATE_SYSPARM
/*****
EXEC SQL CALL SYSPROC.ADMIN_UPDATE_SYSPARM (
      :pmember :ind_pmember,
      :pmodname :ind_pmodname,
      :pmodlib :ind_pmodlib,
      :psrclib :ind_psrclib,
      :pload :ind_pload,
      :pretcd :ind_pretcd);
/*****
/* Retrieve result set when the SQLCODE from the call is +446,
/* which indicates that result sets were returned
/*****
if (SQLCODE == +446)      /* Result sets were returned */
{
  /* Establish a link between the result set and its locator
EXEC SQL ASSOCIATE LOCATORS (:rs_loc1)
      WITH PROCEDURE SYSPROC.ADMIN_UPDATE_SYSPARM;
/* Associate a cursor with the result set
EXEC SQL ALLOCATE C1 CURSOR FOR RESULT SET :rs_loc1;
/* Perform fetches using C1 to retrieve all rows from the
/* result set
EXEC SQL FETCH C1 INTO :rownum, :type, :text;
while(SQLCODE==0)
{

```



```

EXEC SQL FETCH C1 INTO :rownum, :type, :text;
}

EXEC SQL CLOSE C1;
}
return;
}

```

Output

This stored procedure returns the **return-code** output parameter, which is described in “[Option descriptions](#)” on page 816.

In addition to the preceding output, the stored procedure returns one result set that contains successful, warning, or error messages that are generated by the stored procedure. The stored procedure also returns (if applicable) the assembler and link-edit listings, IEBCOPY listing, and output from the SET SYSPARM with LOAD option command.

The following table shows the format of the result set that is returned in the created global temporary table SYSIBM.UPDSYSPARM_MSG:

Table 145. Result set row for the ADMIN_UPDATE_SYSPARM result set

Column name	Data type	Contents
ROWNUM	INTEGER NOT NULL	Sequence number of the table row, from 1 to <i>n</i> .
TYPE	VARCHAR(12) NOT NULL	Type of information that is found in the corresponding TEXT column. Possible values are: <ul style="list-style-type: none"> • DSNADMUZ - TEXT is a message that is internally generated by the stored procedure, such as DSN658I, DSN666I, DSN669I, or DSN685I. • ASSEMBLE - TEXT is a line from the assembler listing. • LINK - TEXT is a line from the link-edit listing. • LOAD - TEXT is a line from the message that is returned by SET SYSPARM with the LOAD option command when this command was issued to load the new subsystem parameters load module into storage. • IEBCOPY1 - TEXT is a line from the IEBCOPY listing which was generated when IEBCOPY was issued to back up the subsystem parameters load module that was being replaced. • IEBCOPY2 - TEXT is a line from the IEBCOPY listing which was generated when IEBCOPY was issued to restore the subsystem parameters load module which the stored procedure replaced with the new subsystem parameters load module. • LOAD2 - TEXT is a line from the message that is returned by SET SYSPARM with the LOAD option command when this command was issued during restore processing to load the current subsystem parameters load module into storage.

Table 145. Result set row for the ADMIN_UPDATE_SYSPARM result set (continued)

Column name	Data type	Contents
TEXT	VARCHAR(1331) NOT NULL	<ul style="list-style-type: none"> • A successful, warning, or error message that is generated by the stored procedure. If the message is longer than 1331 characters, the message continues in the next result set row. • Assembler listing • Link-edit listing • Output from SET SYSPARM with the LOAD option command • IEBCOPY listing



ADMIN_UTL_EXECUTE stored procedure

ADMIN_UTL_EXECUTE is a stored procedure that solves alerts stored in the SYSIBM.SYSAUTOALERTS catalog table within the maintenance windows defined by the SYSIBM.SYSAUTOTIMEWINDOWS catalog table. It is required for the use of autonomic statistics.

GUIP The ADMIN_UTL_EXECUTE stored procedure performs the following tasks:

- Determines the order for resolving alerts.
- Within the maintenance windows that are defined in the SYSIBM.SYSAUTOTIMEWINDOWS catalog table, calls the ADMIN_UTL_SCHEDULE stored procedure to resolve alerts by executing the RUNSTATS utility. For each alert, the options for RUNSTATS are provided in the SYSIBM.SYSAUTOALERTS table.
- Updates the status and output of resolved alerts in the SYSIBM.SYSAUTOALERTS table.
- If the administrative task scheduler is used, reschedules its own execution for the next maintenance window when unsolved alerts remain.

Environment

The ADMIN_UTL_EXECUTE stored procedure runs in a WLM-established stored procedure address space and uses the Resource Recovery Services attachment facility to connect to Db2. The ADMIN_UTL_EXECUTE stored procedure calls ADMIN_UTL_SCHEDULE stored procedures to execute a RUNSTATS operation. The ADMIN_UTL_EXECUTE stored procedure is required and must be installed and executable.

It calls the DSNADM.ADMIN_TASK_LIST and the SYSPROC.ADMIN_TASK_UPDATE routines.

Authorization required

To execute the CALL statement, the owner of the package or plan that contains the CALL statement must have DBADM or higher authority.

Syntax

```

▶▶ CALL — SYSPROC.ADMIN_UTL_EXECUTE — ( — execute-options — , — history-entry-id — , —▶
▶ — return-code — , — message — ) ▶▶

```

Option descriptions

The ADMIN_UTL_EXECUTE stored procedure has the following options:

execute-options

A string representation of the configuration parameters for the ADMIN_UTL_EXECUTE stored procedure, consisting of "NAME=VALUE" pairs separated by commas. Optional parameters include:

STAND-ALONE

NO

The ADMIN_UTL_EXECUTE stored procedure interacts with the administrative task scheduler to its own next execution. NO is the default value.

YES

The ADMIN_UTL_EXECUTE stored procedure does not interact with the administrative task scheduler.

execute-options is an input parameter of type VARCHAR(30000).

history-entry-id

Provides a unique identifier that can be used to read the execution log written in the SYSIBM.SYSAUTORUNS_HIST table when the SYSPROC.ADMIN_UTL_EXECUTE stored procedure executes. This is an output parameter of type BIGINT.

return-code

Provides the return code from the stored procedure. Possible values are:

0

The call completed successfully.

4

The call completed successfully. The message output parameter contains a warning message.

12

The call did not complete successfully. The message output parameter contains messages describing the error.

The *return-code* parameter is an output parameter of type INTEGER.

message

Contains messages describing the error encountered by the stored procedure.

The *message* parameter is an output parameter of type VARCHAR(1331)

Example

The following example shows a Java call to the ADMIN_UTL_EXECUTE stored procedure:

```
long taskid = 7;
CallableStatement callStmt =
con.prepareStatement("CALL SYSPROC.ADMIN_UTL_EXECUTE(?, ?, ?, ?)");
callStmt.setString(1, "");
callStmt.registerOutParameter(2, Types.BIGINT);
callStmt.registerOutParameter(3, Types.INTEGER);
callStmt.registerOutParameter(4, Types.LONGVARCHAR);
callStmt.execute();
if ( callStmt.getInt(3) > 0 )
{
    System.err.println("Error: " + callStmt.getString(4));
}
```

External input

The ADMIN_UTL_EXECUTE stored procedure reads additional input from the SYSIBM.SYSAUTOALERTS and SYSIBM.SYSAUTOTIMEWINDOWS catalog tables.

Output

The ADMIN_UTL_EXECUTE stored procedure returns the following output parameters:

- *history-entry-id*
- *return-code*
- *message*

The ADMIN_UTL_EXECUTE stored procedure also updates the following catalog tables:

- In the SYSIBM.SYSAUTOALERTS catalog table, the following columns are updated for each alert that is solved:
 - STARTTS
 - ENDTS
 - STATUS
 - RETURN_CODE
 - MESSAGE
 - OUTPUT
- In the SYSIBM.SYSAUTORUNS_HIST stored procedure, one row of data is added to log the activity.



Related tasks

[Automating statistics maintenance \(Db2 Performance\)](#)

[Specifying time windows for collecting autonomic statistics \(Db2 Performance\)](#)

Related reference

[SYSAUTOALERTS catalog table](#)

The SYSAUTOALERTS table contains one row for each recommendation from autonomic procedures. The schema is SYSIBM.

ADMIN_UTL_MONITOR stored procedure

SYSPROC.ADMIN_UTL_MONITOR is an autonomic stored procedure that provides functions that enable analysis of database statistics. These functions include alerts for out-of-date, missing, or conflicting statistics, summary reports and detailed table-level reports that describe generated RUNSTATS statements. It is required for the use of autonomic statistics.

The ADMIN_UTL_MONITOR stored procedure enables for the analysis of database statistics, by providing the following functions:

- Issuing RUNSTATS alerts for out-of-date statistics. Counters in the SYSIBM.SYSTABLESPACESTATS table are used to identify out of date statistics. Cloned table spaces, work file table spaces, and directory table spaces are excluded from AUTOSTATS processing.
- Issuing RUNSTATS alerts for missing and conflicting database statistics, including statistics for columns, column groups, and indexes.
- Generating a summary report for the number of tables analyzed and the number of RUNSTATS alerts that were generated.
- Generating detailed table-level reports for RUNSTATS commands, including explanations.
- Scheduling execution of the ADMIN_UTL_EXECUTE stored procedure in the administrative task scheduler to resolve alerts.

Environment

The ADMIN_UTL_MONITOR stored procedure runs in a WLM-established address space and uses the Resource Recovery Services attachment facility to connect to Db2. The ADMIN_UTL_MONITOR stored procedure is required and must be installed and executable.

If the stand-alone option is set to NO, the ADMIN_UTL_MONITOR stored procedure must be defined as a trusted context in RACF and must run in a specific trusted WLM environment to get a RACF PassTicket for the user that called the stored procedure. The ADMIN_UTL_MONITOR stored procedure calls the following interface routines:

- SYSPROC.ADMIN_TASK_ADD
- SYSPROC.ADMIN_TASK_REMOVE
- SYSPROC.ADMIN_TASK_UPDATE
- DSNADM.ADMIN_TASK_LIST
- DSNADM.ADMIN_TASK_STATUS

Authorization required

To execute the CALL statement, the owner of the package or plan that contains the CALL statement must have DBADM or higher authority.

Syntax

The following syntax diagram shows the SQL CALL statement for invoking the ADMIN_UTL_MONITOR stored procedure:

```

▶▶ CALL — ADMIN_UTL_MONITOR — ( — monitor-options — , — history-entry-id — , →
      ▶ — return-code — , — message — ) ▶▶
  
```

Option descriptions

The ADMIN_UTIL_MONITOR stored procedure has the following options:

monitor-options

A string representation of the configuration parameters for the ADMIN_UTIL_MONITOR stored procedure, consisting of "NAME = VALUE" pairs separated by commas. Values, including blanks, equal sign, and comma must be surrounded by single or double quotation marks. For example:

- restrict-ts= 'partition=1' is valid.
- restrict-ts="partition=1" is valid.
- restrict-ts=partition=1 is not valid.

Any value that contains single or double quotation marks must be surrounded by the opposite kind of quotation marks. For example: restrict-ts="DBNAME= 'DSNDB06 ' " is valid because the single quotation marks used in the value are surrounded by double quotation marks.

The following optional parameters are available:

- The following parameters specify general monitoring options:

restrict-ts

Indicates which table spaces require checking. Allowed values are strings that contain valid contents for a WHERE clause on the SYSIBM.SYSTABLESPACESTATS catalog table. For example:

```
DBNAME LIKE 'MYDB%'
```

If no restriction is specified, all table spaces are checked.

stand-alone

Whether alerts trigger the ADMIN_UTL_EXECUTE stored procedure:

NO

Alerts are written and the ADMIN_UTL_EXECUTE stored procedure is called to resolve the alerts. NO is the default value.

YES

Alerts are written but no call is issued to the ADMIN_UTL_EXECUTE stored procedure.

statistics-scope

Specifies the scope of the statistics for the ADMIN_UTL_MONITOR stored procedure to check:

BASIC

Out-of-date statistics are checked, such as whether RUNSTATS has been run since the last LOAD or REORG operation or whether the number and percentage of changes in a table space are greater than a defined threshold. BASIC is the default value.

PROFILE

Out-of-date statistics and the completeness of statistics are checked, including whether all statistics in the table profile have been collected.

PROFILE-CONSISTENCY

Out-of-date statistics, the completeness of statistics, and the consistency of statistics are checked.

- The following optional parameters specify a threshold and settings for the use of table-sampling by RUNSTATS.

sampling-rate

Indicates the percentage of rows that RUNSTATS samples when collecting statistics on non-indexed columns. You can specify any value from 1 through 100. When sampling-rate is not specified, AUTO is used. When a sampling-rate is not specified, the TABLESAMPLE SYSTEM AUTO option is used for RUNSTATS alerts on single-table table spaces and the SAMPLE 25 option is used for RUNSTATS alerts on multi-table table spaces.

sampling-threshold

Indicates a threshold for the absolute number of rows in a table. When the threshold is exceeded, a sampling option is recorded in the RUNSTATS alert, and that option is used later when RUNSTATS executes to resolve the alert. You can specify a positive integer. A value of 500,000 is used when sampling-threshold is not specified. The specified sampling-rate is used for all tables when you specify sampling-threshold=0.

- The following optional parameters specify thresholds for out-of-date statistics. A RUNSTATS alert might be written when a threshold is exceeded.

Table 146. Parameters for out-of-date statistics

Option	Description	Allowed values	Default value
num-changes	Absolute number of inserted, updated, or deleted rows in a table space. A RUNSTATS alert is written when the thresholds for both num-changes and pct-changes are exceeded.	Positive integers, in the range 0 to 2,147,483,647	0
num-mass-deletes	Absolute number of massive delete operations. A RUNSTATS alert is written when the num-mass deletes threshold is exceeded.	Positive integers, in the range 0 to 2,147,483,647	0
pct-changes	Percentage of inserted, updated, or deleted rows in a table space. A RUNSTATS alert is written when the thresholds for both num-changes and pct-changes are exceeded.	A real number float value greater than 0.0 and less than or equal to 100.0	20.0

- The following parameters specify thresholds for inconsistent statistics. The thresholds apply only when the value of profile-consistency is specified for statistics-scope. A RUNSTATS alert is written when a threshold is exceeded. Each threshold is a percentage difference when related statistics are compared, as described in the following table.

Table 147. Parameters for statistics consistency thresholds

Option	Description	Allowed values	Default value
colgroup-card-greater-than-superset-colgroup-card	The cardinality of a column group is greater than the cardinality of its superset column group.	A real number between 0.0 and 100.0 inclusive	0.1
different-colgroup-card-from-coldist-and-index	The cardinalities of an index column group and a table column group that contain the same columns do not match.	A real number between 0.0 and 100.0 inclusive	0.1
different-colgroup-card-from-indexes	The cardinalities of two index column groups that contain the same columns (independent of order) do not match.	A real number between 0.0 and 100.0 inclusive	0.1
different-single-col-colgroup-card-from-coldist-and-index	An index first key cardinality differs from the corresponding column cardinality	A real number between 0.0 and 100.0 inclusive	0.1
different-single-col-colgroup-card-from-indexes	An index first key cardinality differs from another index first key cardinality on the same column.	A real number between 0.0 and 100.0 inclusive	0.1
drf-greater-than-tabcard	The data repetition factor of an index on a table is greater than the cardinality of this table.	A real number between 0.0 and 100.0 inclusive	0.1
drf-less-than-npages	The data repetition factor of an index on a table is smaller than the number of pages.	A real number between 0.0 and 100.0 inclusive	0.1
frequency-out-of-range	A column group frequency of a table is greater than 1 or smaller than 0.	A real number between 0.0 and 100.0 inclusive	0.1
index-fullkeycard-less-than-any-key-card	The full key cardinality of an index is smaller than the cardinality of any column that is involved with the index.	A real number between 0.0 and 100.0 inclusive	0.1
index-fullkeycard-less-than-firstkeycard	The full key cardinality of an index is smaller than the first key cardinality of the same index	A real number between 0.0 and 100.0 inclusive	0
maximum-frequency-less-than-reciprocal-of-colgroup-card	The maximal frequency of a column group is smaller than 1 divided by the cardinality of the column group.	A real number between 0.0 and 100.0 inclusive	0.1
number-of-frequency-records-greater-than-colgroup-card	The number of frequency records of a column group is greater than the cardinality of a column group.	A real number between 0.0 and 100.0 inclusive	0.1

Table 147. Parameters for statistics consistency thresholds (continued)

Option	Description	Allowed values	Default value
product-of-colcard-less-than-colgroup-card	The product of the cardinalities of the columns of a column group is smaller than the cardinality of the column group.	A real number between 0.0 and 100.0 inclusive	0
quantile-card-greater-than-colcard	The cardinality of a quantile in a column group, on a single column, is greater than the cardinality of the column.	A real number between 0.0 and 100.0 inclusive	0.1
quantile-card-greater-than-colgroup-card	The cardinality of a quantile in a column of a table is greater than the cardinality of the same column.	A real number between 0.0 and 100.0 inclusive	0.1
quantile-frequency-out-of-range	The cardinality of a column group quantile is smaller than 0 or greater than 1.	A real number between 0.0 and 100.0 inclusive	0
single-col-index-fullkeycard-not-equal-firstkeycard	The full key cardinality of an index, on a single column, is different from the first key cardinality.	A real number between 0.0 and 100.0 inclusive	0.1
sum-of-frequency-greater-than-one	The sum of all frequencies of a column group of a table is greater than one.	A real number between 0.0 and 100.0 inclusive	0.1
sum-of-histogram-frequency-greater-than-one	The sum of all histogram frequencies of a column group is greater than one.	A real number between 0.0 and 100.0 inclusive	0
sum-of-histogram-greater-than-colcard	The sum of histogram cardinalities of a column of column group is greater than 1.	A real number between 0.0 and 100.0 inclusive	0.1
sum-of-histogram-greater-than-colgroup-card	The sum of histogram cardinalities of a column group is greater than the cardinality of the same column group.	A real number between 0.0 and 100.0 inclusive	0.1
tabcard-less-than-colcard	A table cardinality is smaller than the cardinality of a column in the same table	A real number between 0.0 and 100.0 inclusive	0.1
tabcard-less-than-colgroup-card	A table cardinality is smaller than the cardinality of a column group for this same table.	A real number between 0.0 and 100.0 inclusive	0.1
tabcard-less-than-index-keycard	The cardinality of a table is smaller than the cardinality of an index for this table.	A real number between 0.0 and 100.0 inclusive	0.1
tabcard-not-equal-unique-index-fullkeycard	The cardinality of a table is different from the cardinality of a unique index on that table.	A real number between 0.0 and 100.0 inclusive	0.1

monitor-options is an input parameter of type VARCHAR(30000).

history-entry-id

Returns a unique identifier that can be used to read the execution log in the SYSIBM.SYSAUTORUNS_HIST table and the alerts in the SYSIBM.SYSAUTOALERTS table when the SYSPROC.ADMIN_UTL_MONITOR stored procedure executes. This is an output parameter of type BIGINT.

return-code

Provides the return code from the stored procedure. Possible values are:

0

The call completed successfully.

4

The call completed successfully. The message output parameter contains a warning message.

12

The call did not complete successfully. The message output parameter contains messages describing the error.

The *return-code* parameter is an output parameter of type INTEGER.

message

Contains messages describing the error encountered by the stored procedure.

The *message* parameter is an output parameter of type VARCHAR(1331)

Example

The following example shows a Java call to the ADMIN_UTL_MONITOR stored procedure:

```
CallableStatement callStmt =
con.prepareCall("CALL SYSPROC.ADMIN_UTL_MONITOR(?, ?, ?, ?)");
callStmt.setString(1, "");
callStmt.registerOutParameter(2, Types.INTEGER);
callStmt.registerOutParameter(3, Types.INTEGER);
callStmt.registerOutParameter(4, Types.LONGVARCHAR);
callStmt.execute();
if ( callStmt.getInt(3) > 0 )
{
System.err.println("Error: " + callStmt.getString(4));
}
```

External input

The ADMIN_UTL_MONITOR stored procedure reads additional input from the following catalog tables:

- SYSIBM.SYSTABLESPACESTATS
- SYSIBM.SYSTABLESPACE
- SYSIBM.SYSTABLES
- SYSIBM.SYSCOLUMNNS
- SYSIBM.SYSCOLDIST
- SYSIBM.SYSINDEXES
- SYSIBM.SYSKEYS
- SYSIBM.SYSTABLES_PROFILES

Output

The ADMIN_UTL_MONITOR stored procedure returns the following output parameters:

- *history-entry-id*
- *return-code*
- *message*

The ADMIN_UTL_MONITOR stored procedure also inserts rows of data into the following catalog tables:

- In the SYSIBM.SYSAUTOALERTS catalog table, a row of data is inserted for each RUNSTATS alert issued, with values for following columns:
 - HISTORY_ENTRY_ID
 - ACTION
 - TARGET_QUALIFIER
 - TARGET_OBJECT
 - TARGET_PARTITION
 - OPTIONS
 - DURATION
 - STATUS
- In the SYSIBM.SYSTABLES_PROFILES catalog table, a row of data is inserted for each monitored table that doesn't have a profile yet, with values in the following columns:
 - SCHEMA
 - TBNAME
 - PROFILE_TYPE
 - PROFILE_MODE
 - PROFILE_TEXT
 - PROFILE_UPDATE
 - PROFILE_USED
- In the SYSIBM.SYSAUTORUNS_HIST stored procedure, one row of data is added to log the activity. 

Related concepts

[Statistics profiles \(Db2 Performance\)](#)

Related tasks

[Automating statistics maintenance \(Db2 Performance\)](#)

ADMIN_UTL_MODIFY stored procedure

ADMIN_UTL_MODIFY is an autonomic stored procedure that maintains the SYSIBM.SYSAUTORUNS_HIST and SYSIBM.SYSAUTOALERTS catalog tables.

 The ADMIN_UTL_MODIFY stored procedure removes all entries in the SYSIBM.SYSAUTORUNS_HIST table that are older than a configurable threshold and removes all entries in the SYSIBM.SYSAUTOALERTS table that are older than the configured threshold and are in COMPLETE state.

Environment

The ADMIN_UTL_MODIFY stored procedure runs in a WLM-established address space and uses the Resource Recovery Services attachment facility to connect to Db2. The ADMIN_UTL_MODIFY stored procedure is required and must be installed and executable.

Authorization required

To execute the CALL statement, the owner of the package or plan that contains the CALL statement must have DBADM or higher authority.

Syntax

```
► CALL — ADMIN_UTL_MODIFY — ( — modify-options — , — history-entry-id — , —  
    ► — return-code — , — message — ) ►
```

Option descriptions

The ADMIN_UTL_MODIFY stored procedure has the following options:

modify-options

A string representation of the configuration parameters for the ADMIN_UTIL_MODIFY stored procedure, consisting of "NAME = VALUE" pairs separated by commas. Optional parameters include:

HISTORY-DAYS

Number of days after that entries in the SYSIBM.SYSAUTORUNS_HIST table and completed alerts in SYSIBM.SYSAUTOALERTS table are deleted. The value be a positive number of days.

modify-options is an input parameter of type VARCHAR(30000)

history-entry-id

Returns a unique identifier that can be used to read the execution log in the SYSIBM.SYSAUTORUNS_HIST table when the SYSPROC.ADMIN_UTL_MODIFY stored procedure executes. This is an output parameter of type BIGINT.

return-code

Provides the return code from the stored procedure. Possible values are:

0

The call completed successfully.

4

The call completed successfully. The message output parameter contains a warning message.

12

The call did not complete successfully. The message output parameter contains messages describing the error.

The *return-code* parameter is an output parameter of type INTEGER.

message

Contains messages describing the error encountered by the stored procedure.

The *message* parameter is an output parameter of type VARCHAR(1331)

Example

The following example shows a Java call to the ADMIN_UTL_MODIFY stored procedure:

```
String options = "history-days=90";  
CallableStatement callStmt =  
con.prepareStatement("CALL SYSPROC.ADMIN_UTL_MODIFY(?, ?, ?, ?)");  
callStmt.setString(1, options);  
callStmt.registerOutParameter(2, Types.INTEGER);  
callStmt.registerOutParameter(3, Types.INTEGER);  
callStmt.registerOutParameter(4, Types.LONGVARCHAR);  
callStmt.execute();  
if ( callStmt.getInt(3) > 0 )  
{  
    System.err.println("Error: " + callStmt.getString(4));  
}
```

External input

The AUTO_UTL_MODIFY stored procedure reads additional input from the SYSIBM.SYSAUTORUNS_HIST and SYSIBM.SYSAUTOALERTS catalog tables.

Output

The ADMIN_UTL_MONITOR stored procedure returns the following output parameters:

- *history-entry-id*
- *return-code*
- *message*

The ADMIN_UTL_MODIFY stored procedure also deletes rows from the SYSIBM.SYSAUTORUNS_HIST and SYSIBM.SYSAUTOALERTS tables and inserts a single row in to the SYSIBM.SYSAUTORUNS_HIST table to log its activity. 

Related tasks

[Automating statistics maintenance \(Db2 Performance\)](#)

[Scheduling log and alert history cleanup for autonomic statistics \(Db2 Performance\)](#)

ADMIN_UTL_SCHEDULE stored procedure

The SYSPROC.ADMIN_UTL_SCHEDULE stored procedure executes utilities in parallel.

Environment



ADMIN_UTL_SCHEDULE runs in a WLM-established stored procedures address space.

Authorization

To execute the CALL statement, the owner of the package or plan that contains the CALL statement must have one or more of the following privileges on each package that the stored procedure uses:

- The EXECUTE privilege on the package for DSNADMUM
- Ownership of the package
- PACKADM authority for the package collection
- SYSADM authority

The ADMIN_UTL_SCHEDULE stored procedure internally calls the following stored procedures:

- ADMIN_COMMAND_DB2, to execute the Db2 DISPLAY UTILITY command
- ADMIN_INFO_SSID, to obtain the subsystem ID of the connected Db2 subsystem
- ADMIN_UTL_SORT, to sort objects into parallel execution units
- DSNUTILU, to run the requested utilities

The owner of the package or plan that contains the CALL ADMIN_UTL_SCHEDULE statement must also have the authorization required to execute these stored procedures and run the requested utilities. To determine the privilege or authority required to call DSNUTILU, see [“DSNUTILU stored procedure” on page 906](#).

Syntax

The following syntax diagram shows the SQL CALL statement for invoking this stored procedure:

```

▶ CALL — SYSPROC.ADMIN_UTL_SCHEDULE — ( — max-parallel — , — optimize-workload — , —
NULL — , — stop-condition — , — utility-ID-stem — , — shutdown-duration — , —
NULL — , — number-of-objects — , — utilities-run — , — highest-return-code — , — parallel-tasks — , —
return-code — , — message — ) ▶▶

```

Option descriptions

max-parallel

Specifies the maximum number of parallel threads that may be started. The actual number may be lower than the requested number based on the optimizing sort result. Possible values are 1 to 99.

This is an input parameter of type SMALLINT and cannot be null.

optimize-workload

Specifies whether the parallel utility executions should be sorted to achieve shortest overall execution time. Possible values are:

NO or null

The workload is not to be sorted.

YES

The workload is to be sorted.

This is an input parameter of type VARCHAR(8). The default value is NO.

stop-condition

Specifies the utility execution condition after which ADMIN_UTL_SCHEDULE will not continue starting new utility executions in parallel, but will wait until all currently running utilities have completed and will then return to the caller. Possible values are:

AUTHORIZ or null

No new utility executions will be started after one of the currently running utilities has encountered a return code from DSNUTILU of 12 or higher.

WARNING

No new utility executions will be started after one of the currently running utilities has encountered a return code from DSNUTILU of 4 or higher.

ERROR

No new utility executions will be started after one of the currently running utilities has encountered a return code from DSNUTILU of 8 or higher.

This is an input parameter of type VARCHAR(8). The default value is AUTHORIZ.

utility-ID-stem

Specifies the first part of the utility ID of a utility execution in a parallel thread. The complete utility ID is dynamically created in the form *utility-ID-stem* followed by *TT* followed by *NNNNNN*, where:

TT

The zero-padded number of the subtask executing the utility

NNNNNN

A consecutive number of utilities executed in a subtask.

For example, utilityidstem02000005 is the fifth utility execution that has been processed by the second subtask.

This is an input parameter of type VARCHAR(8) and cannot be null.

shutdown-duration

Specifies the elapsed time in seconds that ADMIN_UTL_SCHEDULE will allow utility executions before a shutdown is initiated. When a shutdown is initiated, current utility executions can run to completion, and no new utility will be started. Possible values are:

null

A shutdown will not be performed.

1 to 999999999999999

A shutdown will be performed after this many seconds.

This is an input parameter of type FLOAT(8). The default value is null.

number-of-objects

As an input parameter, this specifies the number of utility executions and their sorting objects that were passed in the SYSIBM.UTILITY_OBJECTS table. Possible values are 1 to 999999.

As an output parameter, this specifies the number of objects that were passed in SYSIBM.UTILITY_OBJECTS table that are found in the Db2 catalog.

This is an input and output parameter of type INTEGER and cannot be null.

utilities-run

Indicates the number of actual utility executions.

This is an output parameter of type INTEGER.

highest-return-code

Indicates the highest return code from DSNUTILU for all utility executions.

This is an output parameter of type INTEGER.

parallel-tasks

Indicates the actual number of parallel tasks that were started to execute the utility in parallel.

This is an output parameter of type SMALLINT.

return-code

Provides the return code from the stored procedure. Possible values are:

0

All parallel utility executions ran successfully.

4

The statistics for one or more sorting objects have not been gathered in the catalog.

12

An ADMIN_UTL_SCHEDULE error occurred or all the objects passed in the SYSIBM.UTILITY_OBJECTS table are not found in the Db2 catalog. The *message* parameter contains details.

This is an output parameter of type INTEGER.

message

Contains messages describing the error encountered by the stored procedure. If no error occurred, then no message is returned.

The first messages in this area are generated by the stored procedure. Messages that are generated by Db2 might follow the first messages.

This is an output parameter of type VARCHAR(1331).

Additional input

In addition to the input parameters, the stored procedure reads from the created global temporary tables SYSIBM.UTILITY_OBJECTS and SYSIBM.UTILITY_STMT.

The stored procedure reads objects for utility execution from SYSIBM.UTILITY_OBJECTS. The following table shows the format of the created global temporary table SYSIBM.UTILITY_OBJECTS:

Table 148. Format of the input objects

Column name	Data type	Contents
OBJECTID	INTEGER	A unique positive identifier for the object the utility execution is associated with. When you insert multiple rows, increment OBJECTID by 1, starting at 0 for every insert.
STMTID	INTEGER	A statement row in SYSIBM.UTILITY_STMT
TYPE	VARCHAR(10)	Object type: <ul style="list-style-type: none">• TABLESPACE• INDEXSPACE• TABLE• INDEX• STOGROUP
QUALIFIER	VARCHAR(128)	Qualifier (database or creator) of the object in NAME, empty or null for STOGROUP. If the qualifier is not provided and the type of the object is TABLESPACE or INDEXSPACE, then the default database is DSNDB04. If the object is of the type TABLE or INDEX, the schema is the current SQL authorization ID.
NAME	VARCHAR(128)	Unqualified name of the object. NAME cannot be null. If the object no longer exists, it will be ignored and the corresponding utility will not be executed.
PART	SMALLINT	Partition number of the object for which the utility will be invoked. Null or 0 if the object is not partitioned.
RESTART	VARCHAR(8)	Restart parameter of DSNUTILU

Table 148. Format of the input objects (continued)

Column name	Data type	Contents
UTILITY_NAME	VARCHAR(20)	<p>Utility name. UTILITY_NAME cannot be null.</p> <p>Recommendation: Sort objects for the same utility.</p> <p>Possible values are:</p> <ul style="list-style-type: none"> • CHECK DATA • CHECK INDEX • CHECK LOB • COPY • COPYTOCOPY • DIAGNOSE • LOAD • MERGECOPY • MODIFY RECOVERY • MODIFY STATISTICS • QUIESCE • REBUILD INDEX • RECOVER • REORG INDEX • REORG LOB • REORG TABLESPACE • REPAIR • REPORT RECOVERY • REPORT TABLESPACESET • RUNSTATS INDEX • RUNSTATS TABLESPACE • STOSPACE • UNLOAD

The stored procedure reads the corresponding utility statements from SYSIBM.UTILITY_STMT. The following table shows the format of the created global temporary table SYSIBM.UTILITY_STMT:

Table 149. Format of the utility statements

Column name	Data type	Contents
STMTID	INTEGER	A unique positive identifier for a single utility execution statement

Table 149. Format of the utility statements (continued)

Column name	Data type	Contents
STMTSEQ	INTEGER	If a utility statement exceeds 4000 characters, it can be split up and inserted into SYSIBM.UTILITY_STMT with the sequence starting at 0, and then being incremented with every insert. During the actual execution, the statement pieces are concatenated without any separation characters or blanks in between.
UTSTMT	VARCHAR(4000)	A utility statement or part of a utility statement. A placeholder &OBJECT. can be used to be replaced by the object name passed in SYSIBM.UTILITY_OBJECTS. A placeholder &THDINDEX. can be used to be replaced by the current thread index (01-99) of the utility being executed. You can use this when running REORG with SHRLEVEL CHANGE in parallel, so that you can specify a different mapping table for each thread of the utility execution.

Example

The following C language sample shows how to invoke ADMIN_UTL_SCHEDULE:

```
#include <stdio.h>
#include <stdlib.h>
#include <string.h>

/***** DB2 SQL Communication Area *****/
EXEC SQL INCLUDE SQLCA;

int main( int argc, char *argv[] ) /* Argument count and list */
{
/***** DB2 Host Variables *****/
EXEC SQL BEGIN DECLARE SECTION;

/* SYSPROC.ADMIN_UTL_SCHEDULE parameters */
short int maxparallel; /* Max parallel */
short int ind_maxparallel; /* Indicator variable */
char optimizeworkload[9]; /* Optimize workload */
short int ind_optimizeworkload; /* Indicator variable */
char stoponcond[9]; /* Stop on condition */
short int ind_stoponcond; /* Indicator variable */
char utilityidstem[9]; /* Utility ID stem */
short int ind_utilityidstem; /* Indicator variable */
float shutdownduration; /* Shutdown duration */
short int ind_shutdownduration; /* Indicator variable */
long int numberofobjects; /* Number of objects */
short int ind_numberofobjects; /* Indicator variable */
long int utilitiesexec; /* Utilities executed */
short int ind_utilitiesexec; /* Indicator variable */
long int highestretcd; /* DSNUTILU highest ret code */
short int ind_highestretcd; /* Indicator variable */
long int paralleltasks; /* Parallel tasks */
short int ind_paralleltasks; /* Indicator variable */
long int retcd; /* Return code */
}
```

```

short int ind_retcd;                /* Indicator variable */
char errmsg[1332];                 /* Error message */
short int ind_errmsg;              /* Indicator variable */

/* Temporary table SYSIBM.UTILITY_OBJECTS columns */
long int objectid;                 /* Object id */
long int stmtid;                   /* Statement ID */
char type[11];                     /* Object type (e.g. "INDEX") */
char qualifier[129];              /* Object qualifier */
short int ind_qualifier;          /* Object qualifier ind. var. */
char name[129];                   /* Object name (qual. or unq.) */
short int part;                   /* Optional partition */
short int ind_part;               /* Partition indicator var */
char restart[9];                  /* DSNUTILU restart parm */
char utname[21];                  /* Utility name */

/* Temporary table SYSIBM.UTILITY_STMT columns */
long int stmtid2;                 /* Statement ID */
long int stmtseq;                 /* Utility stmt sequence */
char utstmt[4001];               /* Utility statement */

/* Result set locators */
volatile SQL TYPE IS RESULT_SET_LOCATOR *rs_loc1;
volatile SQL TYPE IS RESULT_SET_LOCATOR *rs_loc2;

/* First result set row */
long int objectid1;               /* Object id */
long int textseq;                 /* Object utility output seq */
char text[255];                  /* Object utility output */

/* Second result set row */
long int objectid2;               /* Object id */
long int utilretcd;              /* DSNUTILU return code */
EXEC SQL END DECLARE SECTION;

/*****
/* Set up the objects to be sorted */
*****/
long int objid_array[4] = {1, 2, 3, 4};
long int stmtid_array[4] = {1, 1, 1, 1};
char type_array[4][11] = {"TABLESPACE", "TABLESPACE",
                          "TABLESPACE", "TABLESPACE"};
char qual_array[4][129] = {"QUAL01", "QUAL01",
                           "QUAL01", "QUAL01"};
char name_array[4][129] = {"TBSP01", "TBSP02",
                           "TBSP03", "TBSP04"};
short int part_array[4] = {0, 0, 0, 0};
char restart_array[4][9] = {"NO", "NO",
                             "NO", "NO"};
char utname_array[4][21] = {"RUNSTATS TABLESPACE",
                            "RUNSTATS TABLESPACE",
                            "RUNSTATS TABLESPACE",
                            "RUNSTATS TABLESPACE"};

int i = 0;                        /* Loop counter */

/*****
/* Set up utility statement */
*****/
stmtid2 = 1;
stmtseq = 1;
strcpy(utstmt,
      "RUNSTATS TABLESPACE &OBJECT. TABLE(ALL) SAMPLE 25 INDEX(ALL)");

/*****
/* Assign values to input parameters */
/* Set the indicator variables to 0 for non-null input parameters */
/* Set the indicator variables to -1 for null input parameters */
*****/
maxparallel = 2;
ind_maxparallel = 0;
strcpy(optimizeworkload, "YES");
ind_optimizeworkload = 0;
strcpy(stoaponcond, "AUTHORIZ");
ind_stoaponcond = 0;
strcpy(utilityidstem, "DSNADMUM");
ind_utilityidstem = 0;
numberofobjects = 4;
ind_numberofobjects = 0;
ind_shutdownduration = -1;

/*****

```

```

/* Clear temporary table SYSIBM.UTILITY_OBJECTS */
/*****
EXEC SQL DELETE FROM SYSIBM.UTILITY_OBJECTS;

/*****
/* Insert the objects into the temporary table */
/* SYSIBM.UTILITY_OBJECTS */
/*****
for (i = 0; i < 4; i++)
{
    objectid = objid_array[i];
    stmtid = stmtid_array[i];
    strcpy(type, type_array[i]);
    strcpy(qualifier, qual_array[i]);
    strcpy(name, name_array[i]);
    part = part_array[i];
    strcpy(restart, restart_array[i]);
    strcpy(utname, utname_array[i]);
    EXEC SQL INSERT INTO SYSIBM.UTILITY_OBJECTS
                (OBJECTID, STMTID, TYPE,
                 QUALIFIER, NAME, PART,
                 RESTART, UTILITY_NAME)
    VALUES (:objectid, :stmtid, :type,
            :qualifier, :name, :part,
            :restart, :utname);
};

/*****
/* Clear temporary table SYSIBM.UTILITY_STMT */
/*****
EXEC SQL DELETE FROM SYSIBM.UTILITY_STMT;

/*****
/* Insert the utility statement into the temporary table */
/* SYSIBM.UTILITY_STMT */
/*****
EXEC SQL INSERT INTO SYSIBM.UTILITY_STMT
                (STMTID, STMTSEQ, UTSTMT)
    VALUES (:stmtid2, :stmtseq, :utstmt);

/*****
/* Call stored procedure SYSPROC.ADMIN_UTL_SCHEDULE */
/*****
EXEC SQL CALL SYSPROC.ADMIN_UTL_SCHEDULE
                (:maxparallel      :ind_maxparallel,
                :optimizeworkload  :ind_optimizeworkload,
                :stoponcond        :ind_stoponcond,
                :utilityidstem     :ind_utilityidstem,
                :shutdownduration  :ind_shutdownduration,
                :numberofobjects   :ind_numberofobjects,
                :utilitiesexec     :ind_utilitiesexec,
                :highestretcd      :ind_highestretcd,
                :paralleltasks     :ind_paralleltasks,
                :retcd             :ind_retcd,
                :errmsg            :ind_errmsg);

/*****
/* Retrieve result set when the SQLCODE from the call is +446, */
/* which indicates that result sets were returned */
/*****
if (SQLCODE == +446) /* Result sets were returned */
{
    /* Establish a link between the result set and its locator */
    EXEC SQL ASSOCIATE LOCATORS (:rs_loc1, :rs_loc2)
        WITH PROCEDURE SYSPROC.ADMIN_UTL_SCHEDULE;

    /* Associate a cursor with the first result set */
    EXEC SQL ALLOCATE C1 CURSOR FOR RESULT SET :rs_loc1;

    /* Associate a cursor with the second result set */
    EXEC SQL ALLOCATE C2 CURSOR FOR RESULT SET :rs_loc2;

    /* Perform fetches using C1 to retrieve all rows from the */
    /* first result set */
    EXEC SQL FETCH C1 INTO :objectid1, :textseq, :text;
    while(SQLCODE==0)
    {
        EXEC SQL FETCH C1 INTO :objectid1, :textseq, :text;
    }

    EXEC SQL CLOSE C1;

```

```

/* Perform fetches using C2 to retrieve all rows from the      */
/* second result set                                          */
EXEC SQL FETCH C2 INTO :objectid2, :utilretcd;
while(SQLCODE==0)
{
  EXEC SQL FETCH C2 INTO :objectid2, :utilretcd;
}
EXEC SQL CLOSE C2;
}
return(retcd);
}

```

Output

This stored procedure returns the following output parameters, which are described in [“Option descriptions”](#) on page 833:

- *number-of-objects*
- *utilities-run*
- *highest-return-code*
- *parallel-tasks*
- *return-code*
- *message*

In addition to the preceding output, the stored procedure returns two result sets.

The first result set is returned in the created global temporary table SYSIBM.UTILITY_SYSPRINT and contains the output from the individual utility executions. The following table shows the format of the created global temporary table SYSIBM.UTILITY_SYSPRINT:

Table 150. Result set row for first ADMIN_UTL_SCHEDULE result set

Column name	Data type	Contents
OBJECTID	INTEGER	A unique positive identifier for the object the utility execution is associated with
TEXTSEQ	INTEGER	Sequence number of utility execution output statements for the object whose unique identifier is specified in the OBJECTID column
TEXT	VARCHAR(254)	A utility execution output statement

The second result set is returned in the created global temporary table SYSIBM.UTILITY_RETCODE and contains the return code for each of the individual DSNUTILU executions. The following table shows the format of the output created global temporary table SYSIBM.UTILITY_RETCODE:

Table 151. Result set row for second ADMIN_UTL_SCHEDULE result set

Column name	Data type	Contents
OBJECTID	INTEGER	A unique positive identifier for the object the utility execution is associated with
RETCODE	INTEGER	Return code from DSNUTILU for this utility execution



Related reference

[DSNUTILU stored procedure](#)

Use the DSNUTILU stored procedure to run Db2 utilities from a Db2 application program.

ADMIN_UTL_SORT stored procedure

The SYSPROC.ADMIN_UTL_SORT stored procedure sorts objects for parallel utility execution using JCL or the ADMIN_UTL_SCHEDULE stored procedure.

Environment



ADMIN_UTL_SORT runs in a WLM-established stored procedures address space.

Authorization

To execute the CALL statement, the owner of the package or plan that contains the CALL statement must have one or more of the following privileges on each package that the stored procedure uses:

- The EXECUTE privilege on the package for DSNADMUS
- Ownership of the package
- PACKADM authority for the package collection
- SYSADM authority

The owner of the package or plan that contains the CALL statement must also have SELECT authority on the following catalog tables:

- SYSIBM.SYSTABLEPART
- SYSIBM.SYSINDEXPART
- SYSIBM.SYSINDEXES
- SYSIBM.SYSTABLES

Syntax

The following syntax diagram shows the SQL CALL statement for invoking this stored procedure:

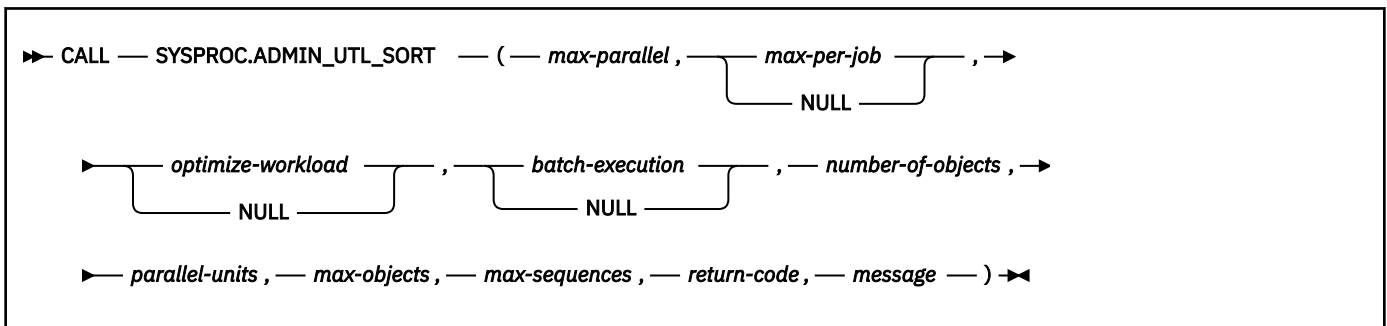

Option descriptions

max-parallel

Specifies the maximum number of parallel units. The actual number may be lower than the requested number based on the optimizing sort result. Possible values are: 1 to 99.

This is an input parameter of type SMALLINT and cannot be null.

max-per-job

Specifies the maximum number of steps per job for batch execution. Possible values are:

1 to 255

Steps per job for batch execution

null

Online execution

This is an input parameter of type SMALLINT. This parameter cannot be null if *batch-execution* is YES.

optimize-workload

Specifies whether the parallel units should be sorted to achieve shortest overall execution time.

Possible values are:

NO or null

The workload is not to be sorted.

YES

The workload is to be sorted.

This is an input parameter of type VARCHAR(8). The default value is NO.

batch-execution

Indicates whether the objects should be sorted for online or batch (JCL) execution.

NO or null

The workload is for online execution.

YES

The workload is for batch execution.

This is an input parameter of type VARCHAR(8). The default value is NO.

number-of-objects

As an input parameter, this specifies the number of objects that were passed in SYSIBM.UTILITY_SORT_OBJ. Possible values are: 1 to 999999.

As an output parameter, this specifies the number of objects that were passed in SYSIBM.UTILITY_SORT_OBJ table that are found in the Db2 catalog.

This is an input and output parameter of type INTEGER and cannot be null.

parallel-units

Indicates the number of recommended parallel units.

This is an output parameter of type SMALLINT.

max-objects

Indicates the maximum number of objects in any parallel unit.

This is an output parameter of type INTEGER.

max-sequences

Indicates the number of jobs in any parallel unit.

This is an output parameter of type INTEGER.

return-code

Provides the return code from the stored procedure. Possible values are:

0

Sort ran successfully.

4

The statistics for one or more sorting objects have not been gathered in the catalog or the object no longer exists.

12

An ADMIN_UTL_SORT error occurred. The *message* parameter will contain details.

This is an output parameter of type INTEGER.

message

Contains messages describing the error encountered by the stored procedure. If no error occurred, then no message is returned.

The first messages in this area are generated by the stored procedure. Messages that are generated by Db2 might follow the first messages.

This is an output parameter of type VARCHAR(1331).

Additional input

In addition to the input parameters, this stored procedure reads the objects for sorting and the corresponding utility names from the created global temporary table SYSIBM.UTILITY_SORT_OBJ.

The following table shows the format of the created global temporary table SYSIBM.UTILITY_SORT_OBJ:

Table 152. Input for the ADMIN_UTL_SORT stored procedure

Column name	Data type	Contents
OBJECTID	INTEGER	A unique positive identifier for the object the utility execution is associated with. When you insert multiple rows, increment OBJECTID by 1, starting at 0 for every insert.
TYPE	VARCHAR(10)	Object type: <ul style="list-style-type: none">• TABLESPACE• INDEXSPACE• TABLE• INDEX• STOGROUP
QUALIFIER	VARCHAR(128)	Qualifier (database or creator) of the object in NAME, empty or null for STOGROUP. If the qualifier is not provided and the type of the object is TABLESPACE or INDEXSPACE, then the default database is DSNDB04. If the object is of the type TABLE or INDEX, the schema is the current SQL authorization ID. If the object no longer exists, it will be ignored.
NAME	VARCHAR(128)	Unqualified name of the object. NAME cannot be null.
PART	SMALLINT	Partition number of the object for which the utility will be invoked. Null or 0 if the object is not partitioned.

Table 152. Input for the ADMIN_UTL_SORT stored procedure (continued)

Column name	Data type	Contents
UTILITY_NAME	VARCHAR(20)	<p>Utility name. UTILITY_NAME cannot be null.</p> <p>Recommendation: Sort objects for the same utility.</p> <p>Possible values are:</p> <ul style="list-style-type: none"> • CHECK DATA • CHECK INDEX • CHECK LOB • COPY • COPYTOCOPY • DIAGNOSE • LOAD • MERGECOPY • MODIFY RECOVERY • MODIFY STATISTICS • QUIESCE • REBUILD INDEX • RECOVER • REORG INDEX • REORG LOB • REORG TABLESPACE • REPAIR • REPORT RECOVERY • REPORT TABLESPACESET • RUNSTATS INDEX • RUNSTATS TABLESPACE • STOSPACE • UNLOAD

Example

The following C language sample shows how to invoke ADMIN_UTL_SORT:

```
#include <stdio.h>
#include <stdlib.h>
#include <string.h>

/***** DB2 SQL Communication Area *****/
EXEC SQL INCLUDE SQLCA;

int main( int argc, char *argv[] ) /* Argument count and list */
{
  /***** DB2 Host Variables *****/
  EXEC SQL BEGIN DECLARE SECTION;

  /* SYSPROC.ADMIN_UTL_SORT parameters */
  short int maxparallel; /* Max parallel */
  short int ind_maxparallel; /* Indicator variable */
  short int maxperjob; /* Max per job */
  short int ind_maxperjob; /* Indicator variable */
}
```



```

char optimizeworkload[9];          /* Optimize workload          */
short int ind_optimizeworkload;    /* Indicator variable         */
char batchexecution[9];           /* Batch execution            */
short int ind_batchexecution;     /* Indicator variable         */
long int numberofobjects;        /* Number of objects         */
short int ind_numberofobjects;    /* Indicator variable         */
short int parallelunits;         /* Parallel units            */
short int ind_parallelunits;     /* Indicator variable         */
long int maxobjects;             /* Maximum objects per      */
                                /* parallel unit             */
short int ind_maxobjects;        /* Indicator variable         */
long int maxseqs;               /* Maximum jobs per unit    */
short int ind_maxseqs;          /* Indicator variable         */
long int retcd;                 /* Return code                */
short int ind_retcd;            /* Indicator variable         */
char errmsg[1332];              /* Error message              */
short int ind_errmsg;           /* Indicator variable         */

/* Temporary table SYSIBM.UTILITY_SORT_OBJ columns */
long int objectid;             /* Object id                  */
char type[11];                 /* Object type (e.g. "INDEX") */
char qualifier[129];          /* Object qualifier           */
short int ind_qualifier;      /* Object qualifier ind. var. */
char name[129];               /* Object name (qual. or unq.) */
short int part;               /* Optional partition        */
short int ind_part;           /* Partition indicator var    */
char utname[21];              /* Utility name                */

/* Result set locators */
volatile SQL TYPE IS RESULT_SET_LOCATOR *rs_loc1;

/* Result set row */
long int resobjectid;          /* Object id                  */
short int unit;               /* Execution unit value       */
long int unitseq;             /* Job seq within exec unit   */
long int unitseqpos;          /* Pos within exec unit or    */
                                /* step within job            */
char exclusive[2];           /* Exclusive execution flag    */
EXEC SQL END DECLARE SECTION;

/*****
/* Set up the objects to be sorted */
/*****
long int objid_array[4] = {0, 1, 2, 3};
char type_array[4][11] = {"TABLESPACE", "TABLESPACE",
                          "TABLESPACE", "TABLESPACE"};
char qual_array[4][129] = {"QUAL01", "QUAL01",
                           "QUAL01", "QUAL01"};
char name_array[4][129] = {"TBSP01", "TBSP02",
                           "TBSP03", "TBSP04"};
short int part_array[4] = {0, 0, 0, 0};
char utname_array[4][21] = {"RUNSTATS TABLESPACE",
                            "RUNSTATS TABLESPACE",
                            "RUNSTATS TABLESPACE",
                            "RUNSTATS TABLESPACE"};

int i = 0;                      /* Loop counter */

/*****
/* Assign values to input parameters */
/* Set the indicator variables to 0 for non-null input parameters */
/* Set the indicator variables to -1 for null input parameters */
/*****
maxparallel = 2;
ind_maxparallel = 0;
ind_maxperjob = -1;
strcpy(optimizeworkload, "YES");
ind_optimizeworkload = 0;
strcpy(batchexecution, "NO");
ind_batchexecution = 0;
numberofobjects = 4;
ind_numberofobjects = 0;

/*****
/* Clear temporary table SYSIBM.UTILITY_SORT_OBJ */
/*****
EXEC SQL DELETE FROM SYSIBM.UTILITY_SORT_OBJ;

/*****
/* Insert the objects into the temporary table */
/* SYSIBM.UTILITY_SORT_OBJ */
/*****

```

```

for (i = 0; i < 4; i++)
{
  objectid = objid_array[i];
  strcpy(type, type_array[i]);
  strcpy(qualifier, qual_array[i]);
  strcpy(name, name_array[i]);
  part = part_array[i];
  strcpy(utname, utname_array[i]);
  EXEC SQL INSERT INTO SYSIBM.UTILITY_SORT_OBJ
                (OBJECTID, TYPE, QUALIFIER, NAME, PART,
                 UTILITY_NAME)
                VALUES (:objectid, :type, :qualifier, :name, :part,
                        :utname);
};

/*****
/* Call stored procedure SYSPROC.ADMIN_UTL_SORT */
/*****
EXEC SQL CALL SYSPROC.ADMIN_UTL_SORT
                (:maxparallel           :ind_maxparallel,
                :maxperjob              :ind_maxperjob,
                :optimizeworkload      :ind_optimizeworkload,
                :batchexecution        :ind_batchexecution,
                :numberofobjects       :ind_numberofobjects,
                :parallelunits         :ind_parallelunits,
                :maxobjects             :ind_maxobjects,
                :maxseqs               :ind_maxseqs,
                :retcd                 :ind_retcd,
                :errmsg                :ind_errmsg);

/*****
/* Retrieve result set when the SQLCODE from the call is +446, */
/* which indicates that result sets were returned */
/*****
if (SQLCODE == +446) /* Result sets were returned */
{
  /* Establish a link between the result set and its locator */
  EXEC SQL ASSOCIATE LOCATORS (:rs_loc1)
        WITH PROCEDURE SYSPROC.ADMIN_UTL_SORT;

  /* Associate a cursor with the result set */
  EXEC SQL ALLOCATE C1 CURSOR FOR RESULT SET :rs_loc1;

  /* Perform fetches using C1 to retrieve all rows from the */
  /* result set */
  EXEC SQL FETCH C1 INTO :resobjectid, :unit,
                        :unitseq, :unitseqpos, :exclusive;

  while(SQLCODE==0)
  {
    EXEC SQL FETCH C1 INTO :resobjectid, :unit,
                          :unitseq, :unitseqpos, :exclusive;
  }

  EXEC SQL CLOSE C1;
}

return(retcd);
}

```

Output

This stored procedure returns the following output parameters, which are described in “[Option descriptions](#)” on page 841:

- *number-of-objects*
- *parallel-units*
- *max-objects*
- *max-sequences*
- *return-code*
- *message*

In addition to the preceding output, the stored procedure returns one result set that contains the objects sorted into parallel execution units.

The following table shows the format of the result set returned in the created global temporary table SYSIBM.UTILITY_SORT_OUT:

Table 153. Result set row for ADMIN_UTL_SORT result set

Column name	Data type	Contents
OBJECTID	INTEGER	A unique positive identifier for the object
UNIT	SMALLINT	Number of parallel execution unit
UNIT_SEQ	INTEGER	Job sequence within parallel execution unit
UNIT_SEQ_POS	INTEGER	Step within job
EXCLUSIVE	CHAR(1)	Requires execution with nothing running in parallel



CREATE_WRAPPED stored procedure

The CREATE_WRAPPED procedure encodes a readable data definition statement into an obfuscated data definition statement and then deploys the object in the database. The procedural logic and embedded SQL statements in an *obfuscated data definition statement* are scrambled in such a way that any intellectual property in the logic cannot be easily extracted.

►► CALL — CREATE_WRAPPED — (— *object-definition-string* —) ►►

The schema is SYSIBMADM.

object-definition-string

A string of any built-in character type that contains any of the following data definition statements:

- CREATE FUNCTION (compiled SQL scalar)
- CREATE FUNCTION (inlined SQL scalar)
- CREATE FUNCTION (SQL table)
- CREATE PROCEDURE (SQL - native)
- CREATE TRIGGER (basic)
- CREATE TRIGGER (advanced)

object-definition-string must not be bit data, and it cannot contain the VERSION keyword.

The procedure encodes the input into an obfuscated data definition statement string and then dynamically executes that data definition statement. The encoded statement consists of the following parts:

- The original statement up to and including the routine signature or trigger name.
- The WRAPPED keyword.
- The product identifier of the database manager that invoked the function.

The product identifier (PRDID) value is an 8-byte character value in *pppvrrm* format, where: *ppp* is a 3-letter product code; *vv* is the version; *rr* is the release; and *m* is the modification level. In Db2 12 for z/OS, the modification level indicates a range of function levels:

DSN12015 for V12R1M500 or higher.
DSN12010 for V12R1M100.

For more information, see [Product identifier \(PRDID\) values in Db2 for z/OS \(Db2 Administration Guide\)](#).

- The encoded remainder of the data definition statement, in the form of a string of letters (a-z and A-Z), digits (0-9), underscores, and colons. It is converted to Unicode UTF-8 before it is encoded. An error is issued if *object-definition-string* cannot be converted or if the intermediate string exceeds the maximum length for SQL statements. A warning occurs if a character is converted to the substitution character.

The encoded data definition statement can be up to one-third longer than the plain text form of the statement. If the result exceeds the maximum length for SQL statements, an error is issued.

Examples

Example 1

The following procedure call produces an obfuscated version of a function that computes a yearly salary from an hourly wage given a 40 hour work week.

```
CALL CREATE_WRAPPED('CREATE FUNCTION salary(wage DECFLOAT)
RETURNS DECFLOAT
RETURN wage * 40 * 52');
SELECT TEXT FROM SYSIBM.SYSROUTINES
WHERE NAME = 'SALARY' AND SCHEMA = CURRENT SCHEMA;
```

The result is similar to the following form:

```
CREATE FUNCTION salary(wage DECFLOAT) WRAPPED DSN12015
ab1GWmdiWmtyTmduTmJqTmtaUmtCumZqUmdiXodK3idaWmdaWmdaWmZG1mIaG
icaGy31TyStm_qGbe3sDxdxjtC8ymVGLpMXnuL81kmNuRhhZ6qYJ2YYdXGaa
```

Example 2

The following procedure call produces an obfuscated version of a trigger that sets a complex default value

```
CALL CREATE_WRAPPED('CREATE OR REPLACE TRIGGER trig1
BEFORE INSERT ON emp
REFERENCING NEW AS n FOR EACH ROW
WHEN (n.bonus IS NULL)
SET n.bonus = n.salary * .04')
SELECT STATEMENT FROM SYSIBM.SYSTRIGGERS
WHERE NAME='TRIG1' AND SCHEMA= CURRENT SCHEMA;
```

The result is similar to the following form:

```
CREATE TRIGGER trig1 WRAPPED DSN12015
ab1GWmdiWmtyTmduTmJqTmtaUmtGUnteUmZKwmtqWidaWmdaWmdaXmdyWncaGica
GK6ot_81NzyodncdrRIJFp_tBjpJeIwg_dTKNHcdtHPSaNCpmqBKH2pMwExkRTJW
Zr:dJd0_gSbehW:4Xx1UGPGnDxvmJfa5ZAG0r_1sfFiyaPrkOXzt5UMTmsASfyJR
ksbPfm2d1ATbq:0RW
```

Related tasks

[Obfuscating source code of SQL procedures, SQL functions, and triggers \(Db2 Administration Guide\)](#)

Related reference

[WRAP scalar function](#)

The WRAP built-in function encodes a readable data definition statement into an obfuscated data definition statement. The procedural logic and embedded SQL statements in an *obfuscated data definition statement* are scrambled in such a way that any intellectual property in the logic cannot be easily extracted.

DSNACCOX stored procedure

The Db2 real-time statistics stored procedure (DSNACCOX) is a sample stored procedure that makes recommendations to help you maintain your Db2 databases.

PSPI

The DSNACCOX stored procedure replaced the DSNACCOR stored procedure, which is not supported in Db2 12. DSNACCOX provides the following improvements over DSNACCOR:

- Improved recommendations
- New fields
- New formulas
- The option to choose the formula for making recommendations

You can call the DSNACCOX stored procedure to accomplish the following actions:

- Get recommendations for when to reorganize, image copy, or update statistics for table spaces or index spaces
- Identify when a data set has exceeded a specified threshold for the number of extents that it occupies.
- Identify whether objects are in restricted states

DSNACCOX uses data from catalog tables, including real-time statistics tables, to make its recommendations. DSNACCOX provides its recommendations in a result set.

DSNACCOX uses the set of criteria that are shown in [“DSNACCOX formulas for recommending actions” on page 862](#) to evaluate table spaces and index spaces. By default, DSNACCOX evaluates all table spaces and index spaces in the subsystem that have entries in the real-time statistics tables. However, you can override this default through input parameters.

About DSNACCOX recommendations

- You can improve the quality of DSNACCOX recommendations, especially for frequently changed objects, by externalizing in-memory statistics to the real-time statistics tables immediately before calling the stored procedure. For more information, see:

[Updating real-time statistics immediately \(Db2 Performance\)](#)

[When Db2 externalizes real-time statistics \(Db2 Performance\)](#)

[-ACCESS DATABASE command \(Db2\) \(Db2 Commands\)](#)

- DSNACCOX makes recommendations based on general formulas that require input from the user about the maintenance policies for a subsystem. These recommendations might not be accurate for every installation.
- If the real-time statistics tables contain information for only a small percentage of your Db2 subsystem, the recommendations that DSNACCOX makes might not be accurate for the entire subsystem.
- Before you perform any action that DSNACCOX recommends, ensure that the object for which DSNACCOX makes the recommendation is available, and that the recommended action can be performed on that object. For example, REORG might be recommended for an object, but the object might be stopped.

Environment

DSNACCOX must run in a WLM-established stored procedure address space. The DSNWLM_GENERAL core WLM environment is a suitable environment for this stored procedure.

DSNACCOX is installed and configured by installation job DSNTIJRT, which binds the package for DSNACCOX with isolation UR to avoid lock contention.

Authorization required

To execute the CALL DSNACCOX statement, the owner of the package or plan that contains the CALL statement must have one or more of the following privileges on each package that the stored procedure uses:

- The EXECUTE privilege on the package for DSNACCOX
- Ownership of the package
- PACKADM authority for the package collection
- SYSADM authority

The owner of the package or plan that contains the CALL statement must also have:

- SELECT authority on catalog tables
- The DISPLAY privilege

Syntax diagram

The following syntax diagram shows the CALL statement for invoking DSNACCOX. Because the linkage convention for DSNACCOX is GENERAL WITH NULLS, if you pass parameters in host variables, you need to include a null indicator with every host variable. Null indicators for input host variables must be initialized before you execute the CALL statement.

For more information, see:

[Indicator variables, arrays, and structures \(Db2 Application programming and SQL\)](#)

[Linkage conventions for external stored procedures \(Db2 Application programming and SQL\)](#)

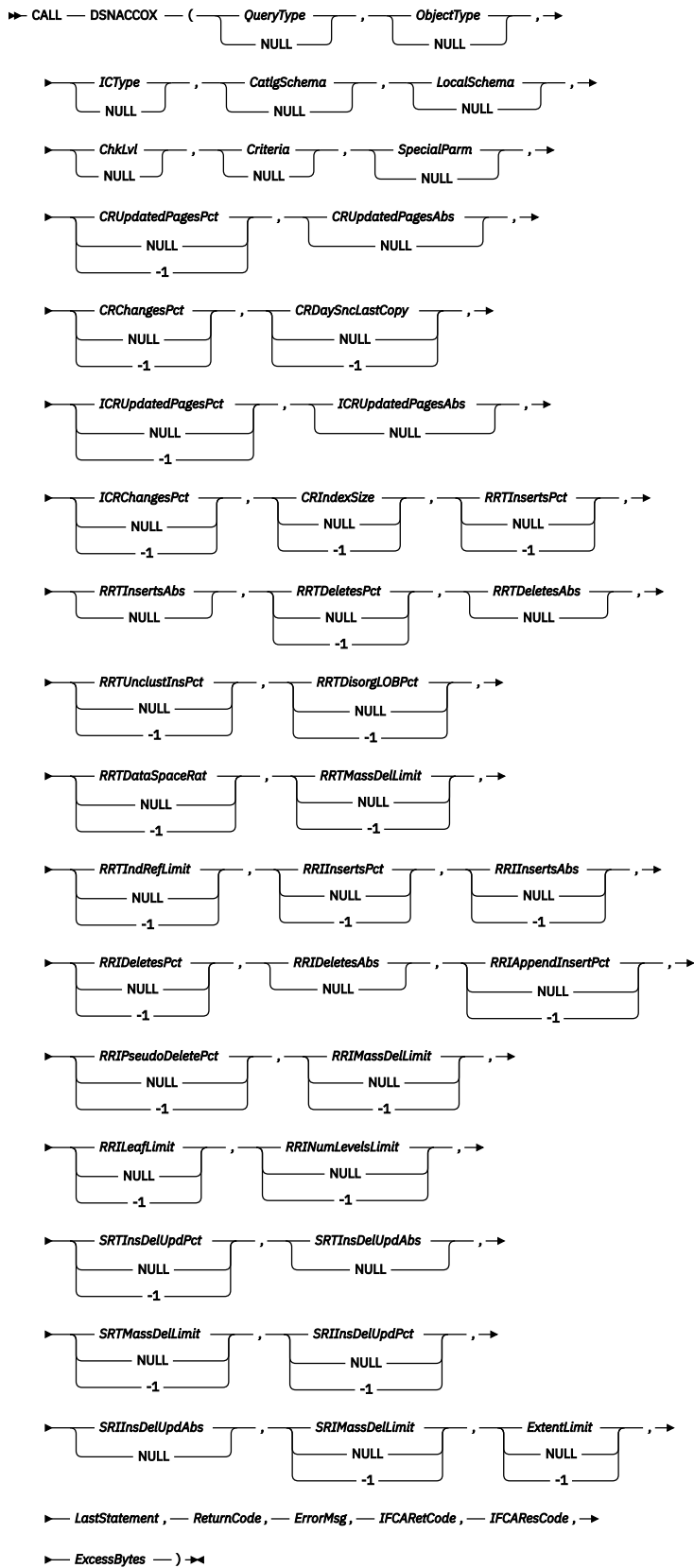

SpecialParm

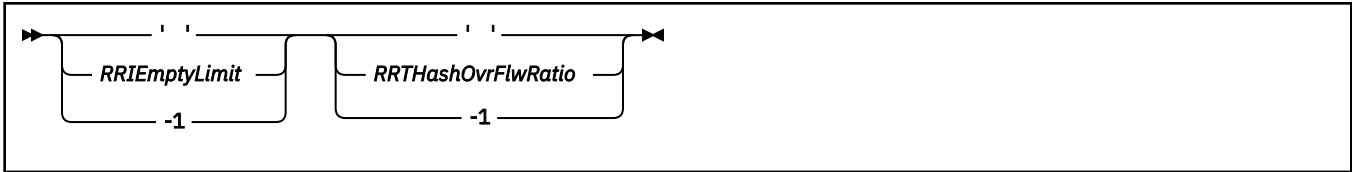

Option descriptions

In the following option descriptions, the default value for an input parameter is the value that DSNACCOX uses if you specify a null value.

QueryType

Specifies the types of actions that DSNACCOX recommends. This field contains one or more of the following values. Each value is enclosed in single quotation marks and separated from other values by a space.

ALL

Makes recommendations for all of the following actions.

COPY

Makes a recommendation on whether run an image copy.

RUNSTATS

Makes a recommendation on whether to run RUNSTATS.

REORG

Makes a recommendation on whether to run REORG. Choosing this value causes DSNACCOX to process the EXTENTS value also.

EXTENTS

Indicates when data sets have exceeded a user-specified extents limit.

RESTRICT

Indicates which objects are in a restricted state.

DSNACCOX recommends REORG on the table space when one of the following conditions is true, and REORG (or ALL) is also specified for the value of QUERYTYPE:

- The table space is in REORG-pending status.
- The table space is in advisory REORG-pending status as the result of an ALTER TABLE statement.

DSNACCOX recommends REORG on the index when on the following conditions is true and REORG (or ALL) is also specified for the value of QUERYTYPE:

- The index is in REORG-pending status.
- The index is in advisory REORG-pending as the result of an ALTER TABLE statement.

DSNACCOX recommends FULL COPY on the table space when on the following conditions is true and COPY (or ALL) is also specified for the value of QUERYTYPE:

- The table space is in COPY-pending status.
- The table space is in informational COPY-pending status.

DSNACCOX recommends FULL COPY on the index when on the following conditions is true and COPY (or ALL) is also specified for the value of QUERYTYPE: and SYSINDEX.COPY='Y':

- The index is in COPY-pending status.
- The index is in informational COPY-pending status.

QueryType is an input parameter of type VARCHAR(40). The default value is ALL.

ObjectType

Specifies the types of objects for which DSNACCOX recommends actions:

ALL

Table spaces and index spaces.

TS

Table spaces only.

IX

Index spaces only.

ObjectType is an input parameter of type VARCHAR(3). The default value is ALL.

ICType

Specifies the types of image copies for which DSNACCOX is to make recommendations:

F

Full image copy.

I

Incremental image copy. This value is valid for table spaces only.

B

Full image copy or incremental image copy.

ICType is an input parameter of type VARCHAR(1). The default is B.

CatlgSchema

Specifies the qualifier for Db2 catalog table names. *CatlgSchema* is an input parameter of type VARCHAR(128). The default value is SYSIBM.

LocalSchema

Specifies the qualifier for the names of local tables that DSNACCOX references. *LocalSchema* is an input parameter of type VARCHAR(128). The default value is DSNACC.

ChkLvl

Specifies the types of checking that DSNACCOX performs, and indicates whether to include objects that fail those checks in the DSNACCOX recommendations result set. This value is the sum of any combination of the following values:

0

DSNACCOX performs none of the following actions.

1

Exclude rows from the DSNACCOX recommendations result set for RUNSTATS on:

- Index spaces that are related to tables that are defined as VOLATILE.
- Table spaces for which all of the tables are defined as VOLATILE.

2

Choosing this value causes DSNACCOX to override the default SSDMultiplier value when it makes a REORG recommendation for a table space or table space partition. SSDMultiplier is the value by which *RRTUnclustInsPct* is multiplied when table space data sets are on solid state drives (DRIVETYPE='SSD' in catalog table SYSIBM.SYSTABLESPACESTATS). The default value of SSDMultiplier is 2. If *ChkLvl* is set to 2, SSDMultiplier is 5. See [Figure 27 on page 864](#) for details on how SSDMultiplier is used.

4

Check whether rows that are in the DSNACCOX recommendations result set refer to objects that are in the exception table. For recommendations result set rows that have corresponding exception table rows, copy the contents of the QUERYTYPE column of the exception table to the INEXCEPTTABLE column of the recommendations result set.

8

Check for objects that have restricted states. The value of the *QueryType* option must be ALL or contain RESTRICTED when this value is specified. The OBJECTSTATUS column of the result set indicates the restricted state of the object. A row is added to the result set for each object that has a restricted state.

16

Reserved for future use.

32

Exclude rows from the DSNACCOX recommendations result set for index spaces for which the related table spaces have been recommended for REORG or RUNSTATS.

64

For index spaces that are listed in the DSNACCOX recommendations result set, check whether the related table spaces are listed in the exception table. For recommendations result set rows that have corresponding exception table rows, copy the contents of the QUERYTYPE column of the exception table to the INEXCEPTTABLE column of the recommendations result set. Selecting CHKLVL64 also activates CHKLVLs 32 and 4.

ChkLvl is an input parameter of type INTEGER. The default is 5 (values 1+4).

Criteria

Narrows the set of objects for which DSNACCOX makes recommendations. This value is the search condition of an SQL WHERE clause. *Criteria* is an input parameter of type VARCHAR(4096). The default is that DSNACCOX makes recommendations for all table spaces and index spaces in the subsystem. The search condition can use any column in the result set and wildcards are allowed.

DSNACCOX can optimize the retrieval of recommendations if the *criteria* references only the following columns in the real-time statistics tables:

- DBNAME
- NAME
- PARTITION
- DBID
- PSID

SpecialParm

SpecialParm is an input of type CHAR(160), broken into 4 byte sections to accommodate new options. An empty 4 bytes of EBCDIC blanks indicates that the default is used for the option. An EBCDIC character string of '-1', indicates that this option is not used.

RRIEmptyLimit

Is the ratio of pseudo-empty pages to the total number of leaf pages. Specifies a criterion for recommending that the REORG utility is to be run on an index space. If the following value is greater than RRIEmptyLimit, DSNACCOX recommends running REORG: The number of pseudo-empty leaf pages that were created since the last CREATE, REORG, REBUILD INDEX, or LOAD REPLACE, divided by the total number of leaf pages in the index space or partition, expressed as a percentage.

RRIEmptyLimit is an input parameter of type CHAR(4). The default value is ' 5'. A plus sign (+) preceding the value indicates that the DSNACCOX stored procedure returns the value in the result set. A negative value turns off this criterion.

The ratio of pseudo-empty pages to the total number of leaf pages is returned in column RRIEMPTYLIMIT of the result set.

RRTHashOvrFlwRatio

The ratio of hash access overflow index entries to the total number of rows. Specifies a criterion for recommending that the REORG utility is to be run on a table space. If the following condition is true, DSNACCOX recommends running REORG: The hash access overflow index is being used for access, and the ratio of hash access overflow index entries divided by the total number of rows (expressed as a percentage) is greater than RRTHashOvrFlwRatio.

RRTHashOvrFlwRatio is an input parameter of type CHAR(4). The default value is ' 15'. A plus sign (+) preceding or after the value or by itself indicates that the DSNACCOX stored procedure returns the calculated ratio value in the result set. The value of the *ObjectType* parameter must be ALL, or contain both TS and IX, for this criterion to be used. A negative value turns off this criterion.

The ratio of Hash Access overflow index entries to the total number of rows is returned in the RRTHASHOVRFLWRAT column of the result set.

CRUpdatedPagesPct

Is the ratio of the total number of distinct updated pages to the total number of preformatted pages. Specifies, when combined with *CRUpdatedPagesAbs*, a criterion for recommending a full image copy on a table space or index space. If both of the following conditions are true for a table space, DSNACCOX recommends an image copy:

- The total number of distinct updated pages, divided by the total number of preformatted pages (expressed as a percentage) is greater than *CRUpdatedPagesPct*.
- The total number of distinct updates pages is greater than *CRUpdatedPagesABS*.

If all of the following conditions are true for an index space, DSNACCOX recommends an image copy:

- The total number of distinct updated pages, divided by the total number of preformatted pages (expressed as a percentage) is greater than *CRUpdatedPagesPct*.
- The total number of distinct updates pages is greater than *CRUpdatedPagesABS*.
- The number of active pages in the index space or partition is greater than *CRIndexSize*.

CRUpdatedPagesPct is an input parameter of type DOUBLE. The default is 20.0. A negative value turns off both this criterion and *CRUpdatedPagesABS*.

CRUpdatedPagesABS

Is the total number of distinct updated pages. Specifies, when combined with *CRUpdatedPagesPct*, a criterion for recommending a full image copy on a table space or index space. If both of the following conditions are true for a table space, DSNACCOX recommends an image copy:

- The total number of distinct updated pages, divided by the total number of preformatted pages (expressed as a percentage) is greater than *CRUpdatedPagesPct*.
- The total number of distinct updated pages is greater than *CRUpdatedPagesAbs*.

If all of the following conditions are true for an index space, DSNACCOX recommends an image copy:

- The total number of distinct updated pages, divided by the total number of preformatted pages (expressed as a percentage) is greater than *CRUpdatedPagesPct*.
- The total number of distinct updates pages is greater than *CRUpdatedPagesAbs*.
- The number of active pages in the index space or partition is greater than *CRIndexSize*.

CRUpdatedPagesAbs is an input parameter of type INTEGER. The default value is 0.

CRChangesPct

Is the ratio of the total number of insert, update, and delete operations to the total number of rows. Specifies a criterion for recommending a full image copy on a table space or index space. If the following condition is true for a table space, DSNACCOX recommends an image copy:

The total number of insert, update, and delete operations since the last image copy, divided by the total number of rows or LOBs in a table space or partition (expressed as a percentage) is greater than *CRChangesPct*.

If both of the following conditions are true for an index table space, DSNACCOX recommends an image copy:

- The total number of insert and delete operations since the last image copy, divided by the total number of entries in the index space or partition (expressed as a percentage) is greater than *CRChangesPct*.
- The number of active pages in the index space or partition is greater than *CRIndexSize*.

CRChangesPct is an input parameter of type DOUBLE. The default is 10.0. A negative value turns off this criterion.

CRDaySncLastCopy

Is the number of days since the last image copy. Specifies a criterion for recommending a full image copy on a table space or index space. If the number of days since the last image copy is greater than this value, DSNACCOX recommends an image copy.

CRDaySncLastCopy is an input parameter of type INTEGER. The default is 7. A negative value turns off this criterion.

ICRUpdatedPagesPct

Is the ratio of the total number of distinct updated pages to the total number of preformatted pages. Specifies a criterion for recommending an incremental image copy on a table space. If both of the following conditions are true, DSNACCOX recommends an incremental image copy:

- The number of distinct pages that were updated since the last image copy, divided by the total number of active pages in the table space or partition (expressed as a percentage) is greater than *ICRUpdatedPagesPct*.
- The number of distinct pages that were updated since last image copy is greater than *ICRUpdatedPagesAbs*.

ICRUpdatedPagesPct is an input parameter of type DOUBLE. The default value is 1.0. A negative value turns off this criterion and *ICRUpdatedPagesAbs*.

ICRUpdatedPagesAbs

Is the total number of distinct updated pages. Specifies, when combined with *ICRUpdatedPagesPct*, a criterion for recommending an incremental image copy on a table space. If both of the following conditions are true, DSNACCOX recommends an incremental image copy:

- The number of distinct pages that were updated since the last image copy, divided by the total number of active pages in the table space or partition (expressed as a percentage) is greater than *ICRUpdatedPagesPct*.
- The number of distinct pages that were updated since last image copy is greater than *ICRUpdatedPagesAbs*.

ICRUpdatedPagesAbs is an input parameter of type INTEGER. The default is 0.

ICRChangesPct

Is the ratio of the total number of insert, update, or delete operations to the total number of rows. Specifies a criterion for recommending an incremental image copy on a table space. If the following condition is true, DSNACCOX recommends an incremental image copy:

The ratio of the number of insert, update, or delete operations since the last image copy, to the total number of rows or LOBs in a table space or partition (expressed as a percentage) is greater than *ICRChangesPct*.

ICRChangesPct is an input parameter of type DOUBLE. The default is 1.0. A negative value turns off this criterion.

CRIndexSize

Is the minimum index size. Specifies the minimum index size before checking the *CRUpdatedPagesPct* or *ICRChangesPct* criteria for recommending a full image copy on an index space.

CRIndexSize is an input parameter of type INTEGER. The default is 50. A negative value turns off this criterion and *ICRChangesPct*.

RRTInsertsPct

Is the ratio of total number of insert operations to the total number of rows. Specifies, when combined with *RRTInsertsAbs*, a criterion for recommending that the REORG utility is to be run on a table space. If both of the following condition are true, DSNACCOX recommends running REORG:

- The sum of insert, update, and delete operations since the last REORG, divided by the total number of rows or LOBs in the table space or partition (expressed as a percentage) is greater than *RRTInsertsPct*
- The sum of insert operations since the last REORG is greater than *RRTInsertsAbs*.

RRTInsertsPct is an input parameter of type DOUBLE. The default value is -1. A negative value turns off this criterion and *RRTInsertsAbs*.

RRTInsertsAbs

Is the total number of insert operations. Specifies, when combined with *RRTInsertsPct*, a criterion for recommending that the REORG utility is to be run on a table space. If both of the following condition are true, DSNACCOX recommends running REORG:

- The sum of insert operations since the last REORG, divided by the total number of rows or in the table space or partition (expressed as a percentage) is greater than *RRTInsertsPct*
- The sum of insert operations since the last REORG is greater than *RRTInsertsAbs*.

RRTInsertsAbs is an input parameter of type INTEGER. The default value is 0.

RRTDeletesPct

Is the ratio of the total number of delete operations to the total number of rows. Specifies, when combined with *RRTDeletesAbs*, a criterion for recommending that the REORG utility is to be run on a table space. If both of the following condition are true, DSNACCOX recommends running REORG:

- The sum of delete operations since the last REORG, divided by the total number of rows or in the table space or partition (expressed as a percentage) is greater than *RRTDeletesPct*
- The sum of delete operations since the last REORG is greater than *RRTDeletesAbs*.

RRTDeletesPct is an input parameter of type DOUBLE. The default value is 25.0. A negative value turns off this criterion and *RRTDeletesAbs*.

RRTDeletesAbs

Is the total number of delete operations. Specifies, when combined with *RRTDeletesPct*, a criterion for recommending that the REORG utility is to be run on a table space. If both of the following condition are true, DSNACCOX recommends running REORG:

- The sum of delete operations since the last REORG, divided by the total number of rows or in the table space or partition (expressed as a percentage) is greater than *RRTDeletesPct*
- The sum of delete operations since the last REORG is greater than *RRTDeletesAbs*.

RRTDeletesAbs is an input parameter of type INTEGER. The default value is 0.

RRTUnclustInsPct

Is the ratio of the total number of unclustered insert operations to the total number of rows. Specifies a criterion for recommending that the REORG utility is to be run on a table space. If the following condition is true, DSNACCOX recommends running REORG:

The number of unclustered insert operations, divided by the total number of rows or LOBs in the table space or partition (expressed as a percentage) is greater than *RRTUnclustInsPct*.

RRTUnclustInsPct is an input parameter of type DOUBLE. A negative value will turn off this criterion.

For solid-state drives (SSD), the value that you specify is multiplied by 2 unless you specify CHKLVL 2. If you specify CHKLVL 2, the value that you specify is multiplied by 5.

For hard disk drives (HDD), the default value is 10.0. For SSDs, the default value is 20.0 unless you specify CHKLVL 2; in this case, the default is 50.0

RRTDisorgLOBPct

Is the ratio of the number of imperfectly chunked LOBs to the total number of rows. Specifies a criterion for recommending that the REORG utility is to be run on a table space. If the following condition is true, DSNACCOX recommends running REORG:

The number of imperfectly chunked LOBs, divided by the total number of rows or LOBs in the table space or partition (expressed as a percentage) is greater than *RRTDisorgLOBPct*.

RRTDisorgLOBPct is an input parameter of type DOUBLE. The default is 50.0. A negative value will turn off this criterion.

RRTDataSpaceRat

Is the ratio of the space allocated to the actual space used. Specifies a criterion for recommending that the REORG utility is to be run on table space for space reclamation. If the following condition is true, DSNACCOX recommends running REORG:

The object is not using hash organization.

The SPACE allocated is greater than RRTDataSpaceRat multiplied by the actual space used.
(SPACE > RRTDataSpaceRat × (DATASIZE/1024))

RRTDataSpaceRat is an input parameter of type DOUBLE. The default value is -1. A negative value turns off this criterion.

RRTMassDelLimit

Is the sum of the number of mass deletes. Specifies a criterion for recommending that the REORG utility is to be run on a table space. If one of the following values is greater than *RRTMassDelLimit*, DSNACCOX recommends running REORG:

- The sum of mass deletes from a segmented or LOB table space since the last REORG or LOAD REPLACE
- The number of dropped tables from a nonsegmented table space since the last REORG or LOAD REPLACE

RRTMassDelLimit is an input parameter of type INTEGER. The default is 0.

RRTIndRefLimit

Is the ratio of the total number of overflow records that were created to the total number of rows. Specifies a criterion for recommending that the REORG utility is to be run on a table space. If the following value is greater than *RRTIndRefLimit*, DSNACCOX recommends running REORG:

The total number of overflow records that were created since the last REORG or LOAD REPLACE, divided by the total number of rows or LOBs in the table space or partition (expressed as a percentage)

RRTIndRefLimit is an input parameter of type DOUBLE. The default is 5.0 in data sharing environment and 10.0 in a non-data sharing environment.

RRIInsertsPct

Is the ratio of the total number of index entries that were inserted to the total number of index entries. Specifies a criterion for recommending that the REORG utility is to be run on an index space. If the both of the following conditions are true, DSNACCOX recommends running REORG:

- The sum of the number of index entries that were inserted since the last REORG, divided by the total number of index entries in the index space or partition (expressed as a percentage) is greater than *RRIInsertsPct*.
- The sum of the number of index entries that were inserted since the last REORG is greater than *RRIInsertsAbs*.

RRIInsertsPct is an input parameter of type DOUBLE. The default is -1. A negative value turns off this criterion and *RRIInsertsAbs*.

RRIInsertsAbs

Is the sum of the number of index entries that were inserted. Specifies a criterion for recommending that the REORG utility is to be run on an index space. If both of the following conditions are true, DSNACCOX recommends running REORG:

- The sum of the number of index entries that were inserted since the last REORG, divided by the total number of index entries in the index space or partition (expressed as a percentage) is greater than *RRIInsertsPct*.
- The sum of the number of index entries that were inserted since the last REORG is greater than *RRIInsertsAbs*.

RRIInsertsAbs is an input parameter of type INTEGER. The default is 0.

RRIDeletesPct

Is the ratio of the sum of the number of index entries that were deleted to the total number of index entries. Specifies a criterion for recommending that the REORG utility is to be run on an index space. If the following value is greater than *RRIDeletesPct*, DSNACCOX recommends running REORG:

- The sum of the number of index entries that were deleted since the last REORG, divided by the total number of index entries in the index space or partition (expressed as a percentage) is greater than *RRIDeletesPct*.
- The sum of the number of index entries that were deleted since the last REORG is greater than *RRIDeletesAbs*.

RRIDeletesPct is an input parameter of type DOUBLE. The default is 30.0. A negative value turns off this criterion and *RRIDeletesAbs*.

RRIDeletesAbs

Is the sum of the number of index entries that were deleted. Specifies a criterion for recommending that the REORG utility is to be run on an index space. If the following value is greater than *RRIDeletesPct*, DSNACCOX recommends running REORG:

- The sum of the number of index entries that were deleted since the last REORG, divided by the total number of index entries in the index space or partition (expressed as a percentage) is greater than *RRIDeletesPct*.
- The sum of the number of index entries that were deleted since the last REORG is greater than *RRIDeletesAbs*.

RRIDeletesAbs is an input parameter of type INTEGER. The default is 0.

RRIAppendInsertPct

Is the ratio of the number of index entries that were inserted with a key value greater than the maximum key value in the index space or partition to the number of index entries. Specifies a criterion for recommending that the REORG utility is to be run on an index space. If the following value is greater than *RRIAppendInsertPct*, DSNACCOX recommends running REORG:

The number of index entries that were inserted since the last REORG, REBUILD INDEX, or LOAD REPLACE with a key value greater than the maximum key value in the index space or partition, divided by the number of index entries in the index space or partition (expressed as a percentage)

RRIAppendInsertPct is an input parameter of type DOUBLE. The default is 20.0. A negative value turns off this criterion.

RRIPseudoDeletePct

Is the ratio of the number of index entries that were pseudo-deleted to the number of index entries. Specifies a criterion for recommending that the REORG utility is to be run on an index space. If the following value is greater than *RRIPseudoDeletePct*, DSNACCOX recommends running REORG:

The number of index entries that were pseudo-deleted since the last REORG, REBUILD INDEX, or LOAD REPLACE, divided by the number of index entries in the index space or partition (expressed as a percentage)

RRIPseudoDeletePct is an input parameter of type DOUBLE. The default is 5.0. A negative value turns off this criterion.

RRIMassDelLimit

Is the sum of the number of mass deletes of index entries. Specifies a criterion for recommending that the REORG utility is to be run on an index space. If the number of mass deletes from an index space or partition since the last REORG, REBUILD, or LOAD REPLACE is greater than this value, DSNACCOX recommends running REORG.

RRIMassDelLimit is an input parameter of type INTEGER. The default is 0. A negative value turns off this criterion.

RRILEafLimit

Is the ratio of the number of index page splits in which the higher part of the split page was far from the location of the original page to the total number of active pages. Specifies a criterion for

recommending that the REORG utility is to be run on an index space. If the following value is greater than *RRILeafLimit*, DSNACCOX recommends running REORG:

The number of index page splits that occurred since the last REORG, REBUILD INDEX, or LOAD REPLACE in which the higher part of the split page was far from the location of the original page, divided by the total number of active pages in the index space or partition (expressed as a percentage)

RRILeafLimit is an input parameter of type DOUBLE. The default is 10.0. A negative value turns off this criterion.

RRINumLevelsLimit

Is the number of levels in the index tree that were added or removed. Specifies a criterion for recommending that the REORG utility is to be run on an index space. If the following value is greater than *RRINumLevelsLimit*, DSNACCOX recommends running REORG:

The number of levels in the index tree that were added or removed since the last REORG, REBUILD INDEX, or LOAD REPLACE

RRINumLevelsLimit is an input parameter of type INTEGER. The default is 0. A negative value turns off this criterion.

SRTInsDelUpdPct

Is the ratio of the total number of insert, update, or delete operations to the total number of rows. Specifies, when combined with *SRTInsDelUpdAbs*, a criterion for recommending that the RUNSTATS utility is to be run on a table space. If both of the following conditions are true, DSNACCOX recommends running RUNSTATS:

- The number of insert, update, or delete operations since the last RUNSTATS on a table space or partition, divided by the total number of rows or LOBs in table space or partition (expressed as a percentage) is greater than *SRTInsDelUpdPct*.
- The sum of the number of inserted and deleted index entries since the last RUNSTATS on an index space or partition is greater than *SRTInsDelUpdAbs*.

SRTInsDelUpdPct is an input parameter of type DOUBLE. The default is 20.0. A negative value turns off this criterion.

SRTInsDelUpdAbs

Is the number of insert, update, and delete operations. Specifies, when combined with *SRTInsDelUpdPct*, a criterion for recommending that the RUNSTATS utility is to be run on a table space. If both of the following conditions are true, DSNACCOX recommends running RUNSTATS:

- The number of insert, update, and delete operations since the last RUNSTATS on a table space or partition, divided by the total number of rows or LOBs in table space or partition (expressed as a percentage) is greater than *SRTInsDelUpdPct*.
- The sum of the number of inserted and deleted index entries since the last RUNSTATS on an index space or partition is greater than *SRTInsDelUpdAbs*.

SRTInsDelUpdAbs is an input parameter of type INTEGER. The default is 0.

SRTMassDelLimit

Is the sum of the number of mass deletes. Specifies a criterion for recommending that the RUNSTATS utility is to be run on a table space. If the following condition is true, DSNACCOX recommends running RUNSTATS:

- The number of mass deletes from a table space or partition since the last REORG or LOAD REPLACE is greater than *SRTMassDelLimit*.

SRTMassDelLimit is an input parameter of type INTEGER. The default is 0.0. A negative value turns off this criterion.

SRIInsDelPct

Is the ratio of the total number of inserted and deleted index entries to the total number of index entries. Specifies, when combined with *SRIInsDelAbs*, a criterion for recommending that the

RUNSTATS utility is to be run on an index space. If both of the following conditions are true, DSNACCOX recommends running RUNSTATS:

- The number of inserted and deleted index entries since the last RUNSTATS on an index space or partition, divided by the total number of index entries in the index space or partition (expressed as a percentage) is greater than *SRIInsDelPct*
- The sum of the number of inserted and deleted index entries since the last RUNSTATS on an index space or partition is greater than *SRIInsDelAbs*

SRIInsDelPct is an input parameter of type DOUBLE. The default is 20.0. A negative value turns off this criterion.

SRIInsDelAbs

Is the total number of inserted and deleted index entries. Specifies, when combined with *SRIInsDelPct*, a criterion for recommending that the RUNSTATS utility is to be run on an index space. If the following condition is true, DSNACCOX recommends running RUNSTATS:

- The number of inserted and deleted index entries since the last RUNSTATS on an index space or partition, divided by the total number of index entries in the index space or partition (expressed as a percentage) is greater than *SRIInsDelPct*
- The sum of the number of inserted and deleted index entries since the last RUNSTATS on an index space or partition is greater than *SRIInsDelAbs*,

SRIInsDelAbs is an input parameter of type INTEGER. The default is 0.

SRIMassDelLimit

Is the sum of the number of mass deletes. Specifies a criterion for recommending that the RUNSTATS utility is to be run on an index space. If the number of mass deletes from an index space or partition since the last REORG, REBUILD INDEX, or LOAD REPLACE is greater than this value, DSNACCOX recommends running RUNSTATS.

SRIMassDelLimit is an input parameter of type INTEGER. The default value is 0. A negative value turns off this criterion.

ExtentLimit

Is the number of physical extents. Specifies a criterion for recommending that the REORG utility is to be run on a table space or index space. Also specifies that DSNACCOX is to warn the user that the table space or index space has used too many extents. DSNACCOX recommends running REORG, and altering data set allocations if the following condition is true:

- The number of physical extents in the index space, table space, or partition is greater than *ExtentLimit*.

ExtentLimit is an input parameter of type INTEGER. The default value is 254. A negative value turns off this criterion.

LastStatement

When DSNACCOX returns a severe error (return code 12), this field contains the SQL statement that was executing when the error occurred. *LastStatement* is an output parameter of type VARCHAR(8012).

ReturnCode

The return code from DSNACCOX execution. Possible values are:

- 0**
DSNACCOX executed successfully.
- 4**
DSNACCOX completed with a warning. For more information about the problem, check the output parameters, such as the *ErrorMsg*, *IFCAResCode*, and *IFCARetCode* parameters.
- 8**
DSNACCOX terminated with errors. The *ErrorMsg* parameter contains a message that describes the error.

12

DSNACCOX terminated with severe errors. The *ErrorMsg* parameter contains a message that describes the error. The *LastStatement* parameter contains the SQL statement that was executing when the error occurred.

14

DSNACCOX terminated because the real-time statistics table were not yet migrated to the catalog.

15

DSNACCOX terminated because it encountered a problem with one of the declared temporary tables that it defines and uses.

16

DSNACCOX terminated because it could not define a declared temporary table.

NULL

DSNACCOX terminated but could not set a return code.

ReturnCode is an output parameter of type INTEGER.

ErrorMsg

Contains information about DSNACCOX execution when DSNACCOX terminates with a non-zero value for *ReturnCode*.

IFCARetCode

Contains the return code from an IFI COMMAND call. DSNACCOX issues commands through the IFI interface to determine the status of objects. *IFCARetCode* is an output parameter of type INTEGER.

IFCAREsCode

Contains the reason code from an IFI COMMAND call. *IFCAREsCode* is an output parameter of type INTEGER.

XsBytes

Contains the number of bytes of information that did not fit in the IFI return area after an IFI COMMAND call. *XsBytes* is an output parameter of type INTEGER.

DSNACCOX formulas for recommending actions

The following formulas specify the criteria that DSNACCOX uses for its recommendations and warnings. The variables in italics are DSNACCOX input parameters. The capitalized variables are columns of the SYSIBM.SYSTABLESPACESTATS or SYSIBM.SYSINDEXSPACESTATS catalog tables.

The following figure shows the formula that DSNACCOX uses to recommend a full image copy on a table space.

```
((QueryType='COPY' OR QueryType='ALL') AND
 (ObjectType='TS' OR ObjectType='ALL') AND
 (Object is not in Persistent Read Only (PRO) status) AND
 (ICType='F' OR ICType='B')) AND
 (COPYLASTTIME IS NULL OR
 REORGLASTTIME>COPYLASTTIME OR
 LOADRLASTTIME>COPYLASTTIME OR
 (CURRENT DATE-COPYLASTTIME)>CRDaySncLastCopy OR
 ((COPYUPDATEDPAGES*100)/NACTIVE>CRUpdatedPagesPct AND
 (COPYUPDATEDPAGES>CRUpdatedPagesAbs)) OR
 (COPYCHANGES*100)/TOTALROWS>CRChangesPct) OR
 ((QueryType='RESTRICT' OR QueryType='ALL') AND
 (ObjectType='TS' OR ObjectType='ALL') AND
 The table space is in COPY-pending status or informational COPY-pending status))
```

Figure 24. DSNACCOX formula for recommending a full image copy on a table space

The following figure shows the formula that DSNACCOX uses to recommend a full image copy on an index space.

```

(((QueryType='COPY' OR QueryType='ALL') AND
 (ObjectType='IX' OR ObjectType='ALL') AND

 (SYSINDEXES.COPY = 'Y')) AND
 (COPYLASTTIME IS NULL OR
 REORGLASTTIME>COPYLASTTIME OR
 LOADRLASTTIME>COPYLASTTIME OR
 REBUILDLASTTIME>COPYLASTTIME OR
 (CURRENT DATE-COPYLASTTIME)>CRDaySncLastCopy OR
 (NACTIVE>CRIndexSize AND
 (((COPYUPDATEDPAGES×100)/NACTIVE>CRUpdatedPagesPct) AND
 (COPYUPDATEDPAGES>CRUpdatedPagesAbs)) OR
 (COPYCHANGES×100)/TOTALENTRIES>CRChangesPct)) OR
 ((QueryType='RESTRICT' OR QueryType='ALL' OR QueryType='COPY') AND
 (ObjectType='IX' OR ObjectType='ALL') AND
 The index space is in COPY-pending status or informational COPY-pending status))

```

Figure 25. DSNACCOX formula for recommending a full image copy on an index space

The following figure shows the formula that DSNACCOX uses to recommend an incremental image copy on a table space.

```

((QueryType='COPY' OR QueryType='ALL') AND
 (ObjectType='TS' OR ObjectType='ALL') AND
 (Object is not in Persistent Read Only (PRO) status) AND
 (ICType='F' OR ICType='B')) AND
 (ICType='I') AND
 COPYLASTTIME IS NOT NULL) AND
 (LOADRLASTTIME>COPYLASTTIME OR
 REORGLASTTIME>COPYLASTTIME OR
 ((COPYUPDATEDPAGES×100)/NACTIVE>ICRUpdatedPagesPct) AND
 (COPYUPDATEDPAGES>ICRUpdatedPagesAbs)) OR
 (COPYCHANGES×100)/TOTALROWS>ICRChangesPct)

```

Figure 26. DSNACCOX formula for recommending an incremental image copy on a table space

The following figure shows the formula that DSNACCOX uses to recommend a REORG on a table space.

```

(((QueryType='REORG' OR QueryType='ALL') AND
 (ObjectType='TS' OR ObjectType='ALL')) AND
 (Object is not in Persistent Read Only (PRO) status) AND
 ( REORGLASTTIME IS NULL OR
 (NACTIVE IS NULL OR NACTIVE > 5) AND
 (((REORGINSERTS×100)/TOTALROWS>RRTInsertsPct)"1" on page 864 AND
 REORGINSERTS>RRTInsertsAbs) OR
 (((REORGDELETES×100)/TOTALROWS>RRTDeletesPct) AND
 REORGDELETES>RRTDeletesAbs) OR
 ((REORGCLUSTERSENS > 0 OR
 (REORGCLUSTERSENS IS NULL)) AND
 (DRIVETYPE = 'SSD' AND
 (REORGUNCLUSTINS×100)/TOTALROWS >
 (RRTUnclustInsPct * SSDMultiplier"5" on page 864)) OR
 (DRIVETYPE = 'HDD' AND
 (REORGUNCLUSTINS×100)/TOTALROWS>
 (RRTUnclustInsPct))) OR
 (REORGDISORGL0B×100)/TOTALROWS>RRTDisorgLOBPct OR
 (Not HASH organized and
 (SPACE > RRTDataSpaceRat × (DATASIZE/1024))) OR
 ((REORGNEARINDREF+REORGFARINDREF)×100)/TOTALROWS>
 RRTIndRefLimit OR
 REORGMASDELETE>RRTMassDelLimit OR
 EXTENTS>ExtentLimit"4" on page 864))) OR
 ((QueryType='REORG' OR QueryType='ALL') AND
 ObjectType='ALL'"2" on page 864 AND
 overflow index for hash access is used"3" on page 864 AND
 (overflow index TOTALENTRY ×100) / TOTALROWS > RRTHashOvrFlwRatio)) OR
 ((QueryType='RESTRICT' OR QueryType='ALL' OR QueryType='REORG') AND
 (ObjectType='TS' OR ObjectType='ALL') AND
 The table space is in advisory or informational reorg pending status)

```

Notes:

1. If *RRTInsertsPct* defaults to -1, DSNACCOX does no checking for *RRTInsertsPct* or *RRTInsertsAbs*. If you want to use this criterion, you need to pass the *RRTInsertsPct* parameter to DSNACCOX.
2. Both IX and TS must be selected, thus *ObjectType=ALL* must be specified to use this criterion. If only TS or IX is specified, and the value of the special parameter contains a plus sign (+) to indicate that the *RRTHASHOVRFLWRAT* column is to be included in the result set, an error message is issued. Otherwise, this criterion does not apply when only TS or IX is specified.
3. The overflow index is used when *SYSINDEXES.HASH = 'Y' AND SYSINDEXSPACESTATS.REORGINDEXACCESS > 0*.
4. If the table space is a LOB table space, and *CHKLVL=1*, the formula does not include *OR EXTENTS>ExtentLimit*.
5. *SSDMultiplier* is the value by which *RRTUnclustInsPct* is multiplied when table space data sets are on solid state drives (*DRIVETYPE='SSD'* in catalog table *SYSIBM.SYSTABLESPACESTATS*). The default value of *SSDMultiplier* is 2. If *ChkLvl* is set to 2, *SSDMultiplier* is 5.

Figure 27. DSNACCOX formula for recommending a REORG on a table space

The following figure shows the formula that DSNACCOX uses to recommend a REORG on an index space.

```

((QueryType='REORG' OR QueryType='ALL') AND
 (ObjectType='IX' OR ObjectType='ALL') AND
 (REORGLASTTIME IS NULL AND REBUILDLASTTIME IS NULL) OR
 (NACTIVE IS NULL OR NACTIVE > 5) AND
 (((REORGINSERTS×100)/TOTALENTRIES>RRIInsertsPct) AND
  REORGINSERTS>RRIInsertsAbs)"1" on page 865 OR
 (((REORGDELETES×100)/TOTALENTRIES>RRIDeletesPct) AND
  REORGDELETES>RRIDeletesAbs) OR
 (REORGAPPENDINSERT×100)/TOTALENTRIES>RRIAppendInsertPct OR
 (REORGPSEUDODELETES×100)/TOTALENTRIES>RRIPseudoDeletePct"2" on page 865 OR
 REORGMASSEDELETE>RRIMassDelLimit OR
 (REORGLAFAFFAR×100)/NACTIVE>RRILeafLimit OR
 REORGNUMLEVELS>RRINumLevelsLimit OR (NPAGES>5 AND
 (NPAGES×100)/NLEAF>RRIEmptyLimit) OR
 EXTENTS>ExtentLimit)) OR
 ((QueryType='RESTRICT' OR QueryType='ALL' OR QueryType='REORG') AND
 (ObjectType='IX' OR ObjectType='ALL') AND
 An index is in advisory-REBUILD-pending stats (ARBDP))

```

Notes:

1. If *RRIInsertsPct* defaults to -1, DSNACCOX does no checking for *RRIInsertsPct* or *RRIInsertsAbs*. If you want to use this criterion, you need to pass the *RRIInsertsPct* parameter to DSNACCOX.
2. If *RRIPseudoDeletePct* is -1, DSNACCOX does no checking for this criterion.

Figure 28. DSNACCOX formula for recommending a REORG on an index space

The following figure shows the formula that DSNACCOX uses to recommend RUNSTATS on a table space.

```

((QueryType='RUNSTATS' OR QueryType='ALL') AND
 (ObjectType='TS' OR ObjectType='ALL') AND
 Table Space is not cloned) AND
 (STATSLASTTIME IS NULL OR
  STATSLASTTIME<LOADRLASTTIME OR
  STATSLASTTIME<REORGLASTTIME OR
  STATSLASTTIME< latest PROFILE_UPDATE for the table space"1" on page 865 OR
  (((STATSINSERTS+STATSDELETES+STATSUPDATES)×100)/TOTALROWS>SRTInsDelUpdPct AND
   (STATSINSERTS+STATSDELETES+STATSUPDATES)>SRTInsDelUpdAbs) OR
  STATSMASSEDELETE>SRTMassDeleteLimit))

```

Figure 29. DSNACCOX formula for recommending RUNSTATS on a table space

Notes:

1. PROFILE_UPDATE is a table-level timestamp column in the SYSIBM.SYSTABLES_PROFILES catalog table. It is updated by RUNSTATS SET or UPDATE. The PROFILE_UPDATE value is not returned as a column in the DSNACCOX result set.

The following figure shows the formula that DSNACCOX uses to recommend RUNSTATS on an index space.

```

((QueryType='RUNSTATS' OR QueryType='ALL') AND
 (ObjectType='IX' OR ObjectType='ALL')
 Table Space for the index is not cloned ) AND
 (STATSLASTTIME IS NULL OR
  STATSLASTTIME<LOADRLASTTIME OR
  STATSLASTTIME<REORGLASTTIME OR
  (((STATSINSERTS+STATSDELETES)×100)/TOTALENTRIES>SRIInsDelPct AND
   (STATSINSERTS+STATSDELETES)>SRIInsDelAbs) OR
  STATSMASSEDELETE>SRIInsDelAbs))

```

Figure 30. DSNACCOX formula for recommending RUNSTATS on an index space

Using an exception table

An exception table is an optional, user-created Db2 table that you can use to place information in the INEXCEPTTABLE column of the recommendations result set. You can put any information in the INEXCEPTTABLE column, but the most common use of this column is to filter the recommendations result set. Each row in the exception table represents an object for which you want to provide information for the recommendations result set.

To create the exception table, issue a CREATE TABLE statement similar to the following one. You can include other columns in the exception table, but you must include at least the columns that are shown. It is best to create a primary key on the exception table to prevent the duplication of rows in the exception table.

```
CREATE TABLE DSNACC.EXCEPT_TBL
(DBNAME CHAR(8) NOT NULL,
NAME CHAR(8) NOT NULL,
QUERYTYPE CHAR(40),
PRIMARY KEY (DBNAME,NAME))
CCSID EBCDIC;
```

The exception table columns have the following meanings:

DBNAME

The database name for an object in the exception table.

NAME

The table space name or index space name for an object in the exception table.

QUERYTYPE

The information that you want to place in the INEXCEPTTABLE column of the recommendations result set.

If you put a null value in this column, DSNACCOX puts the value YES in the INEXCEPTTABLE column of the recommendations result set row for the object that matches the DBNAME and NAME values.

If you plan to put many rows in the exception table, create a nonunique index on DBNAME, NAME, and QUERYTYPE.

After you create the exception table, insert a row for each object for which you want to include information in the INEXCEPTTABLE column. For example, suppose that you want the INEXCEPTTABLE column to contain the string 'IRRELEVANT' for table space STAFF in database DSNDB04. You also want the INEXCEPTTABLE column to contain 'CURRENT' for table space DSN8S12D in database DSN8D12A. Execute these INSERT statements:

```
INSERT INTO DSNACC.EXCEPT_TBL VALUES('DSNDB04 ', 'STAFF ', 'IRRELEVANT');
INSERT INTO DSNACC.EXCEPT_TBL VALUES('DSN8D12A', 'DSN8S12D', 'CURRENT');
```

To use the contents of INEXCEPTTABLE for filtering, include a condition that involves the INEXCEPTTABLE column in the search condition that you specify in your *Criteria* input parameter. For example, Suppose that you want to include all rows for database DSNDB04 in the recommendations result set, except for those rows that contain the string 'IRRELEVANT' in the INEXCEPTTABLE column. You might include the following search condition in your *Criteria* input parameter:

```
DBNAME='DSNDB04' AND INEXCEPTTABLE<>'IRRELEVANT'
```

Example of calling DSNACCOX

The following figure is a COBOL example that shows variable declarations and an SQL CALL for obtaining recommendations for objects in databases DSN8D12A and DSN8D12L. This example also outlines the steps that you need to perform to retrieve the two result sets that DSNACCOX returns. These result sets are described in [“DSNACCOX output” on page 870](#)

```
WORKING-STORAGE SECTION.
*****
* DSNACCOX PARAMETERS *
```

```

*****
01 QUERYTYPE.
   49 QUERYTYPE-LN          PICTURE S9(4) COMP VALUE 40.
   49 QUERYTYPE-DTA        PICTURE X(40)  VALUE 'ALL'.
01 OBJECTTYPE.
   49 OBJECTTYPE-LN         PICTURE S9(4) COMP VALUE 3.
   49 OBJECTTYPE-DTA        PICTURE X(3)   VALUE 'ALL'.
01 ICTYPE.
   49 ICTYPE-LN             PICTURE S9(4) COMP VALUE 1.
   49 ICTYPE-DTA            PICTURE X(1)   VALUE 'B'.
01 CATLGSHEMA.
   49 CATLGSHEMA-LN        PICTURE S9(4) COMP VALUE 128.
   49 CATLGSHEMA-DTA       PICTURE X(128) VALUE 'SYSIBM'.
01 LOCALSCHEMA.
   49 LOCALSCHEMA-LN       PICTURE S9(4) COMP VALUE 128.
   49 LOCALSCHEMA-DTA     PICTURE X(128) VALUE 'DSNACC'.
01 CHKLVL
   49 CHKLVL                PICTURE S9(9) COMP VALUE +3.
01 CRITERIA.
   49 CRITERIA-LN          PICTURE S9(4) COMP VALUE 4096.
   49 CRITERIA-DTA        PICTURE X(4096) VALUE SPACES.
01 SPECIALPARM.
   49 SPECIALPARM-LN       PICTURE S9(4) COMP VALUE 80.
   49 SPECIALPARM-DTA     PICTURE X(80)  VALUE SPACES.
01 CRUPDATEDPAGESPCT
01 CRUPDATEDPAGESABS      USAGE COMP-2 VALUE +0.
01 CRCHANGESPCT          PICTURE S9(9) COMP VALUE +0.
01 CRDAYSNCLASTCOPY       USAGE COMP-2 VALUE +0.
01 ICRUPDATEDPAGESPCT    PICTURE S9(9) COMP VALUE +0.
01 ICRUPDATEDPAGESABS    USAGE COMP-2 VALUE +0.
01 ICRCHANGESPCT         PICTURE S9(9) COMP VALUE +0.
01 CRINDEXSIZE            PICTURE S9(9) COMP VALUE +0.
01 RRTINSERTSPCT         USAGE COMP-2 VALUE +0.
01 RRTINSERTSABS          PICTURE S9(9) COMP VALUE +0.
01 RRTDELETESPCT         USAGE COMP-2 VALUE +0.
01 RRTDELETESABS         PICTURE S9(9) COMP VALUE +0.
01 RRTUNCLUSTINSPCT      USAGE COMP-2 VALUE +0.
01 RRTDISORGLLOBPCT      USAGE COMP-2 VALUE +0.
01 RRTDATASPACERAT        PICTURE S9(9) COMP VALUE +0.
01 RRTMASSDELLIMIT        PICTURE S9(9) COMP VALUE +0.
01 RRTINDREFLIMIT         PICTURE S9(9) COMP VALUE +0.
01 RRIINSERTSPCT         USAGE COMP-2 VALUE +0.
01 RRIINSERTSABS          PICTURE S9(9) COMP VALUE +0.
01 RRIDELETESPCT         USAGE COMP-2 VALUE +0.
01 RRIDELETESABS          PICTURE S9(9) COMP VALUE +0.
01 RRIAPPENDINSERTPCT    USAGE COMP-2 VALUE +0.
01 RRIPEUDODELETEPCT     USAGE COMP-2 VALUE +0.
01 RRIASSDELLIMIT         PICTURE S9(9) COMP VALUE +0.
01 RRILEAFLIMIT           PICTURE S9(9) COMP VALUE +0.
01 RRINUMLEVELSLIMIT     PICTURE S9(9) COMP VALUE +0.
01 SRTINDELUPDPCT         PICTURE S9(9) COMP VALUE +0.
01 SRTINDELUPDABS        PICTURE S9(9) COMP VALUE +0.
01 SRTMASSDELLIMIT        PICTURE S9(9) COMP VALUE +0.
01 SRIINDELPCPT          USAGE COMP-2 VALUE +0.
01 SRIINDELABS           PICTURE S9(9) COMP VALUE +0.
01 SRIMASSDELLIMIT        PICTURE S9(9) COMP VALUE +0.
01 EXTENTLIMIT            PICTURE S9(9) COMP VALUE +0.
01 LASTSTATEMENT.
   49 LASTSTATEMENT-LN     PICTURE S9(4) COMP VALUE 8012.
   49 LASTSTATEMENT-DTA    PICTURE X(8012) VALUE SPACES.
01 RETURNCODE
   49 RETURNCODE            PICTURE S9(9) COMP VALUE +0.
01 ERRORMSG.
   49 ERRORMSG-LN          PICTURE S9(4) COMP VALUE 1331.
   49 ERRORMSG-DTA         PICTURE X(1331) VALUE SPACES.
01 IFCARETCODE
   49 IFCARETCODE          PICTURE S9(9) COMP VALUE +0.
01 IFCARESCODE
   49 IFCARESCODE          PICTURE S9(9) COMP VALUE +0.
01 XSBYTES
   49 XSBYTES               PICTURE S9(9) COMP VALUE +0.

```

```

*****
* INDICATOR VARIABLES. *
* INITIALIZE ALL NON-ESSENTIAL INPUT *
* VARIABLES TO -1, TO INDICATE THAT THE *
* INPUT VALUE IS NULL. *
*****
01 QUERYTYPE-IND          PICTURE S9(4) COMP-4 VALUE +0.
01 OBJECTTYPE-IND         PICTURE S9(4) COMP-4 VALUE +0.
01 ICTYPE-IND             PICTURE S9(4) COMP-4 VALUE +0.
01 CATLGSHEMA-IND        PICTURE S9(4) COMP-4 VALUE -1.
01 LOCALSCHEMA-IND       PICTURE S9(4) COMP-4 VALUE -1.
01 CHKLVL-IND            PICTURE S9(4) COMP-4 VALUE -1.
01 CRITERIA-IND          PICTURE S9(4) COMP-4 VALUE -1.
01 SPECIALPARM-IND       PICTURE S9(4) COMP-4 VALUE -1.

```

```

01 CRUPDATEDPAGESPCT-IND PICTURE S9(4) COMP-4 VALUE -1.
01 CRUPDATEDPAGESABS-IND PICTURE S9(4) COMP-4 VALUE -1.
01 CRCHANGESPCT-IND PICTURE S9(4) COMP-4 VALUE -1.
01 CRDAYSNCLASTCOPY-IND PICTURE S9(4) COMP-4 VALUE -1.
01 ICRUPDATEDPAGESPCT-IND PICTURE S9(4) COMP-4 VALUE -1.
01 ICRUPDATEDPAGESABS-IND PICTURE S9(4) COMP-4 VALUE -1.
01 ICRCHANGESPCT-IND PICTURE S9(4) COMP-4 VALUE -1.
01 CRINDEXSIZE-IND PICTURE S9(4) COMP-4 VALUE -1.
01 RRTINSERTSPCT-IND PICTURE S9(4) COMP-4 VALUE -1.
01 RRTINSERTSABS-IND PICTURE S9(4) COMP-4 VALUE -1.
01 RRTDELETESPCT-IND PICTURE S9(4) COMP-4 VALUE -1.
01 RRTDELETESABS-IND PICTURE S9(4) COMP-4 VALUE -1.
01 RRTUNCLUSTINSPCT-IND PICTURE S9(4) COMP-4 VALUE -1.
01 RRTDISORGLBOPCT-IND PICTURE S9(4) COMP-4 VALUE -1.
01 RRTDATASPACERAT-IND PICTURE S9(4) COMP-4 VALUE -1.
01 RRTMASSDELLIMIT-IND PICTURE S9(4) COMP-4 VALUE -1.
01 RRTINDREFLIMIT-IND PICTURE S9(4) COMP-4 VALUE -1.
01 RRIINSERTSPCT-IND PICTURE S9(4) COMP-4 VALUE -1.
01 RRIINSERTSABS-IND PICTURE S9(4) COMP-4 VALUE -1.
01 RRIDELETESPCT-IND PICTURE S9(4) COMP-4 VALUE -1.
01 RRIDELETESABS-IND PICTURE S9(4) COMP-4 VALUE -1.
01 RRIAPPENDINSERTPCT-IND PICTURE S9(4) COMP-4 VALUE -1.
01 RRIPEUDODELETEPCT-IND PICTURE S9(4) COMP-4 VALUE -1.
01 RRIMASSDELLIMIT-IND PICTURE S9(4) COMP-4 VALUE -1.
01 RRILEAFLIMIT-IND PICTURE S9(4) COMP-4 VALUE -1.
01 RRINUMLEVELSLIMIT-IND PICTURE S9(4) COMP-4 VALUE -1.
01 SRTINSDELUPDPCT-IND PICTURE S9(4) COMP-4 VALUE -1.
01 SRTINSDELUPDABS-IND PICTURE S9(4) COMP-4 VALUE -1.
01 SRTMASSDELLIMIT-IND PICTURE S9(4) COMP-4 VALUE -1.
01 SRIINSDELPT-IND PICTURE S9(4) COMP-4 VALUE -1.
01 SRIINSDELABS-IND PICTURE S9(4) COMP-4 VALUE -1.
01 SRIMASSDELLIMIT-IND PICTURE S9(4) COMP-4 VALUE -1.
01 EXTENTLIMIT-IND PICTURE S9(4) COMP-4 VALUE -1.
01 LASTSTATEMENT-IND PICTURE S9(4) COMP-4 VALUE +0.
01 RETURNRCODE-IND PICTURE S9(4) COMP-4 VALUE +0.
01 ERRORMSG-IND PICTURE S9(4) COMP-4 VALUE +0.
01 IFCARETCODE-IND PICTURE S9(4) COMP-4 VALUE +0.
01 IFCARESCODE-IND PICTURE S9(4) COMP-4 VALUE +0.
01 XSBYTES-IND PICTURE S9(4) COMP-4 VALUE +0

```

PROCEDURE DIVISION.

```

*****
* SET VALUES FOR DSNACCOX INPUT PARAMETERS: *
* - USE THE CHKLVL PARAMETER TO CAUSE DSNACCOX TO CHECK *
* FOR RELATED TABLE SPACES WHEN PROCESSING INDEX *
* SPACES, AND DELETE RECOMMENDATION FOR INDEXSPACES *
* WHEN AN ACTION (SUCH AS REORG) ON THE TABLE SPACE *
* WILL ALSO CAUSE THE ACTION TO BE DONE ON THE INDEX *
* SPACE. (CHKLVL=64) *
* - USE THE CRITERIA PARAMETER TO CAUSE DSNACCOX TO *
* MAKE RECOMMENDATIONS ONLY FOR OBJECTS IN DATABASES *
* DSN8D91A AND DSN8D91L. *
* - FOR THE FOLLOWING PARAMETERS, SET THESE VALUES, *
* WHICH ARE LOWER THAN THE DEFAULTS: *
* CRUPDATEDPAGESPCT 4 *
* CRCHANGESPCT 2 *
* RRTINSDELUPDPCT 2 *
* RRTUNCLUSTINSPCT 5 *
* RRTDISORGLBOPCT 5 *
* RRIAPPENDINSERTPCT 5 *
* SRTINSDELUPDPCT 5 *
* SRIINSDELPT 5 *
* EXTENTLIMIT 3 *
* - EXCLUDE CHECKING FOR THESE CRITERIA BY SET THE *
* FOLLOWING VALUES TO A NEGATIVE VALUE. *
* RRTMASSDELLIMIT -1 *
* RRIMASSDELLIMIT -1 *
*****
MOVE 64 TO CHKLVL.
MOVE SPACES TO CRITERIA-DTA.
MOVE 'DBNAME = 'DSN8D91A'' OR DBNAME = 'DSN8D91L''
TO CRITERIA-DTA.
MOVE 46 TO CRITERIA-LN.
MOVE 4 TO CRUPDATEDPAGESPCT.
MOVE 2 TO CRCHANGESPCT.
MOVE 2 TO RRTINSERTSPCT.
MOVE 5 TO RRTUNCLUSTINSPCT.
MOVE 5 TO RRTDISORGLBOPCT.
MOVE 5 TO RRIAPPENDINSERTPCT.
MOVE 5 TO SRTINSDELUPDPCT.
MOVE 5 TO SRIINSDELPT

```



```

MOVE 3 TO EXTENTLIMIT.
MOVE -1 TO RRTMASSDELLIMIT.
MOVE -1 TO RRIMASSDELLIMIT.
*****
* INITIALIZE OUTPUT PARAMETERS *
*****
MOVE SPACES TO LASTSTATEMENT-DTA.
MOVE 1 TO LASTSTATEMENT-LN.
MOVE 0 TO RETURNCODE-O2.
MOVE SPACES TO ERRORMSG-DTA.
MOVE 1 TO ERRORMSG-LN.
MOVE 0 TO IFCARETCODE.
MOVE 0 TO IFCARESCODE.
MOVE 0 TO XSBYTES.
*****
* SET THE INDICATOR VARIABLES TO 0 FOR NON-NULL INPUT *
* PARAMETERS (PARAMETERS FOR WHICH YOU DO NOT WANT *
* DSNACCOX TO USE DEFAULT VALUES) AND FOR OUTPUT *
* PARAMETERS. *
*****
MOVE 0 TO CHKLVL-IND.
MOVE 0 TO CRITERIA-IND.
MOVE 0 TO CRUPDATEDPAGESPCT-IND.
MOVE 0 TO CRCHANGESPCT-IND.
MOVE 0 TO RRTINSERTSPCT-IND.
MOVE 0 TO RRTUNCLUSTINSPECT-IND.
MOVE 0 TO RRTDISORGLBPCT-IND.
MOVE 0 TO RRIAPPENDINSERTPCT-IND.
MOVE 0 TO SRTINSDELUPDPCT-IND.
MOVE 0 TO SRIINSDELPC-IND.
MOVE 0 TO EXTENTLIMIT-IND.
MOVE 0 TO LASTSTATEMENT-IND.
MOVE 0 TO RETURNCODE-IND.
MOVE 0 TO ERRORMSG-IND.
MOVE 0 TO IFCARETCODE-IND.
MOVE 0 TO IFCARESCODE-IND.
MOVE 0 TO XSBYTES-IND.
MOVE 0 TO RRTMASSDELLIMIT-IND.
MOVE 0 TO RRIMASSDELLIMIT-IND.

```

```

*****
* CALL DSNACCOX *
*****
EXEC SQL
CALL SYSPROC.DSNACCOX
(:QUERYTYPE :QUERYTYPE-IND,
:OBJECTTYPE :OBJECTTYPE-IND,
:ICTYPE :ICTYPE-IND,
:CATLGSCHEMA :CATLGSCHEMA-IND,
:LOCALSCHEMA :LOCALSCHEMA-IND,
:CHKLVL :CHKLVL-IND,
:CRITERIA :CRITERIA-IND,
:SPECIALPARG :SPECIALPARG-IND,
:CRUPDATEDPAGESPCT :CRUPDATEDPAGESPCT-IND,
:CRUPDATEDPAGESABS :CRUPDATEDPAGESABS-IND,
:CRCHANGESPCT :CRCHANGESPCT-IND,
:CRDAYSNCLASTCOPY :CRDAYSNCLASTCOPY-IND,
:ICRUPDATEDPAGESPCT :ICRUPDATEDPAGESPCT-IND,
:ICRUPDATEDPAGESABS :ICRUPDATEDPAGESABS-IND,
:ICRCHANGESPCT :ICRCHANGESPCT-IND,
:CRINDEXSIZE :CRINDEXSIZE-IND,
:RRTINSERTSPCT :RRTINSERTSPCT-IND,
:RRTINSERTSABS :RRTINSERTSABS-IND,
:RRTDELETESPCT :RRTDELETESPCT-IND,
:RRTDELETESABS :RRTDELETESABS-IND,
:RRTUNCLUSTINSPECT :RRTUNCLUSTINSPECT-IND,
:RRTDISORGLBPCT :RRTDISORGLBPCT-IND,
:RRTDATASPACERAT :RRTDATASPACERAT-IND,
:RRTMASSDELLIMIT :RRTMASSDELLIMIT-IND,
:RRTINDREFLIMIT :RRTINDREFLIMIT-IND,
:RRIINSERTSPCT :RRIINSERTSPCT-IND,
:RRIINSERTSABS :RRIINSERTSABS-IND,
:RRIDELETESPCT :RRIDELETESPCT-IND,
:RRIDELETESABS :RRIDELETESABS-IND,
:RRIAPPENDINSERTPCT :RRIAPPENDINSERTPCT-IND,
:RRIPSEUDODELETEPCT :RRIPSEUDODELETEPCT-IND,
:RRIMASSDELLIMIT :RRIMASSDELLIMIT-IND,
:RRILEAFLIMIT :RRILEAFLIMIT-IND,
:RRINUMLEVELSLIMIT :RRINUMLEVELSLIMIT-IND,
:SRTINSDELUPDPCT :SRTINSDELUPDPCT-IND,
:SRTINSDELUPDABS :SRTINSDELUPDABS-IND,

```

```

:SRTMASSELLIMIT      :SRTMASSELLIMIT-IND,
:SRIINSDLPCT        :SRIINSDLPCT-IND,
:SRIINSDLABS        :SRIINSDLABS-IND,
:SRIMASSELLIMIT     :SRIMASSELLIMIT-IND,
:EXTENTLIMIT        :EXTENTLIMIT-IND,
:LASTSTATEMENT      :LASTSTATEMENT-IND,
:RETURNCODE         :RETURNCODE-IND,
:ERRORMSG           :ERRORMSG-IND,e
:IFCARETCODE        :IFCARETCODE-IND,
:IFCARESCODE        :IFCARESCODE-IND,
:XSBYTES            :XSBYTES-IND)
END-EXEC.

```

```

*****
* ASSUME THAT THE SQL CALL RETURNED +466, WHICH MEANS THAT *
* RESULT SETS WERE RETURNED. RETRIEVE RESULT SETS.      *
*****
* LINK EACH RESULT SET TO A LOCATOR VARIABLE
  EXEC SQL ASSOCIATE LOCATORS (:LOC1, :LOC2)
    WITH PROCEDURE SYSPROC.DSNACCOX
  END-EXEC.
* LINK A CURSOR TO EACH RESULT SET
  EXEC SQL ALLOCATE C1 CURSOR FOR RESULT SET :LOC1
  END-EXEC.
  EXEC SQL ALLOCATE C2 CURSOR FOR RESULT SET :LOC2
  END-EXEC.
* PERFORM FETCHES USING C1 TO RETRIEVE ALL ROWS FROM FIRST RESULT SET
* PERFORM FETCHES USING C2 TO RETRIEVE ALL ROWS FROM SECOND RESULT SET

```

DSNACCOX output

If DSNACCOX executes successfully, in addition to the output parameters described in [“Option descriptions”](#) on page 852, DSNACCOX returns two result sets.

The first result set contains the results from IFI COMMAND calls that DSNACCOX makes. The following table shows the format of the first result set.

Table 154. Result set row for first DSNACCOX result set

Column name	Data type	Contents
RS_SEQUENCE	INTEGER	Sequence number of the output line
RS_DATA	CHAR(80)	A line of command output

The second result set contains rows for table spaces, index spaces, or partitions, if both of the following conditions are true for the object:

- If the *Criteria* input parameter contains a search condition, and the search condition is true for the table space, index space, or partition.
- DSNACCOX recommends at least one action for the table space, index space, or partition.

The second result set contains one row for each nonpartitioned table space or nonpartitioning index space. For partitioned table spaces or partitioning indexes, the result set contains one row for each partition.

The following table shows the columns of a result set row.

Table 155. Result set row for second DSNACCOX result set

Column name	Data type “1” on page 879	Description
DBNAME	VARCHAR(24) NOT NULL	Name of the database that contains the object.
NAME	VARCHAR(128) NOT NULL	Table space name, index name, or index space name. Index space name is used if the row is added as a result of checking a restricted state and the index name is not available at the time.

Table 155. Result set row for second DSNACCOX result set (continued)

Column name	Data type ^{“1” on page 879}	Description
PARTITION	INTEGER NOT NULL	Data set number or partition number.
INSTANCE	SMALLINT NOT NULL	Indicates whether the object is associated with a data set instance.
CLONE	CHAR(1)	'Y' or 'N', 'Y' indicates a cloned object.
OBJECTTYPE	CHAR(2) NOT NULL	Db2 object type: <ul style="list-style-type: none"> • 'TS' for a table space • 'IX' for an index space • 'LS' for an LOB table space • 'XS' for an XML table space • 'DB' for a database
INDEXSPACE	VARCHAR(24)	Index space name.
CREATOR	VARCHAR(128)	Index creator name.
OBJECTSTATUS	CHAR(40)	Status of the object: <ul style="list-style-type: none"> • ORPHANED, if the object is an index space with no corresponding table space, or if the object does not exist • If the object is in a restricted state, one of the following values: <ul style="list-style-type: none"> – TS=<i>restricted-state</i>, if OBJECTTYPE is TS – IX=<i>restricted-state</i>, if OBJECTTYPE is IX – LS=<i>restricted-state</i>, if OBJECTTYPE is LS – LX=<i>restricted-state</i>, if OBJECTTYPE is XS <i>restricted-state</i> is one of the status codes that appear in the output of the DISPLAY DATABASE command. For more information, see: <ul style="list-style-type: none"> DSNT362I (Db2 Messages) -DISPLAY DATABASE command (Db2) (Db2 Commands) • A, if the object is in an advisory state. • L, if the object is a logical partition, but not in an advisory state. • AL, if the object is a logical partition and in an advisory state.

Table 155. Result set row for second DSNACCOX result set (continued)

Column name	Data type ^{“1” on page 879}	Description
IMAGECOPY	CHAR(4)	<p>COPY recommendation:</p> <ul style="list-style-type: none"> If the object is a table space, one of the following values: <ul style="list-style-type: none"> FULL Full image copy is recommended INC Incremental image copy is recommended NO Image copy is not recommended. If the object is an index, whether image copy is recommended: YES or NO
RUNSTATS	CHAR(3)	<p>RUNSTATS recommendation: YES, NO, or Y**.</p> <p>Y** indicates that the table space contains volatile and non-volatile tables.</p>
EXTENTS	CHAR(3)	Indicates whether the data sets for the object have exceeded <i>ExtentLimit</i> : YES or NO.
REORG	CHAR(3)	REORG recommendation: YES or NO.
INEXCEPTTABLE	CHAR(40)	<p>A string that contains one of the following values:</p> <ul style="list-style-type: none"> Text that you specify in the QUERYTYPE column of the exception table. YES, if you put a row in the exception table for the object that this result set row represents, but you specify NULL in the QUERYTYPE column. NO, if the exception table exists but does not have a row for the object that this result set row represents. Null, if the exception table does not exist, or if the <i>ChkLvl</i> input parameter does not include the value 4.
ASSOCIATEDTS	VARCHAR(128)	If OBJECTTYPE is IX this value is the name of the table space that is associated with the index space. Otherwise null.
COPYLASTTIME	TIMESTAMP	Timestamp of the last full or incremental image copy on the object. Null if COPY was never run, or if the last COPY execution is unknown.
LOADRLASTTIME	TIMESTAMP	Timestamp of the last LOAD REPLACE on the object. Null if LOAD REPLACE was never run, or if the last LOAD REPLACE execution is unknown.
REBUILDLASTTIME	TIMESTAMP	Timestamp of the last REBUILD INDEX on the object. Null if REBUILD INDEX was never run, or if the last REBUILD INDEX execution is unknown.

Table 155. Result set row for second DSNACCOX result set (continued)

Column name	Data type ^{"1" on page 879}	Description
CRUPDPGSPCT	DOUBLE	<p>If IMAGECOPY contains a value other than NO, the ratio of distinct updated pages to pre-formatted pages, expressed as a percentage. Otherwise null.</p> <p>If the ratio of distinct updated pages to pre-formatted pages, does not exceed the <i>CRUpdatedPagesPct</i> or <i>ICRUpdatedPagesPct</i> (for tables spaces only, when incremental copy is recommended), this value is null.</p>
CRUPDPGSABS	INTEGER	<p>If IMAGECOPY contains a value other than NO, the ratio of distinct updated pages to pre-formatted pages. Otherwise null.</p> <p>If the ratio of distinct updated pages to pre-formatted pages, does not exceed the value specified for <i>CRUpdatedPagesAbs</i> or <i>ICRUpdatedPagesAbs</i> (for tables spaces only, when incremental copy is recommended), this value is null.</p>
CRCPYCHGPCT	DOUBLE	<p>If the object is a table space and the value of IMAGECOPY is any value other than NO, the ratio of the total number insert, update, and delete operations since the last image copy to the total number of rows or LOBs in the table space or partition, expressed as a percentage.</p> <p>If the object is an index and IMAGECOPY is YES, the ratio of the total number of insert and delete operations since the last image copy to the total number of entries in the index space or partition, expressed as a percentage. Otherwise null.</p> <p>If the ratio of the total number insert, update, and delete operations since the last image copy to the total number of rows or LOBs in the table space or partition does not exceed the value specified for <i>CRChangesPct</i> or <i>ICRChangesPct</i> (incremental copy is recommended), this value is null.</p>
CRDAYSELSTCPY	INTEGER	<p>If IMAGECOPY is YES, the number of days since the last image copy. Otherwise null.</p> <p>If the number of days since the last image copy does not exceed the value specified for <i>CrDaySncLastCopy</i>, this value is null.</p>
CRINDEXSIZE	INTEGER	<p>If IMAGECOPY is YES, the number of active pages in the index space or partition. Otherwise null.</p> <p>If the number of active pages in the index space or partition does not exceed the value specified for <i>CRIndexSize</i>, this value is null.</p>

Table 155. Result set row for second DSNACCOX result set (continued)

Column name	Data type ^{“1” on page 879}	Description
REORGLASTTIME	TIMESTAMP	Timestamp of the last REORG on the object. Null if REORG was never run, or if the last REORG execution was terminated.
RRTINSERTSPCT	DOUBLE	<p>If REORG is YES, the ratio of the sum of insert operations since the last REORG to the total number of rows or LOBs in the table space or partition, expressed as a percentage. Otherwise null.</p> <p>If the ratio of the sum of insert operations since the last REORG to the total number of rows or LOBs in the table space or partition does not exceed the value specified for <i>RRTInsertsPct</i>, this value is null.</p>
RRTINSERTSABS	INTEGER	<p>If REORG is YES, the sum of insert operations since the last REORG to the total number of rows in the table space or partition. Otherwise null.</p> <p>If the sum of insert operations since the last REORG to the total number of rows in the table space or partition does not exceed the value specified for <i>RRTInsertsAbs</i>, this value is null.</p>
RRTDELETESPCT	DOUBLE	<p>If REORG is YES, the ratio of the sum of delete operations since the last REORG to the total number of rows in the table space or partition, expressed as a percentage. Otherwise null.</p> <p>If the ratio of the sum of delete operations since the last REORG to the total number of rows in the table space or partition does not exceed the value specified for <i>RRTDeletesPct</i>, this value is null.</p>
RRTDELETESABS	INTEGER	<p>If REORG is YES, the total number of delete operations since the last REORG on a table space or partition. Otherwise null.</p> <p>If the total number of delete operations since the last REORG does not exceed the value specified for <i>RRTDeletesAbs</i>, this value is null.</p>
RRTUNCINSPCT	DOUBLE	<p>If REORG is YES, the ratio of the number of unclustered insert operations to the total number of rows or LOBs in the table space or partition, expressed as a percentage. Otherwise null.</p> <p>If the ratio of the number of unclustered insert operations to the total number of rows or LOBs does not exceed the value specified for <i>RRTUnclustInsPct</i>, this value is null.</p>

Table 155. Result set row for second DSNACCOX result set (continued)

Column name	Data type ^{"1" on page 879}	Description
RRTDISORGLOBPCT	DOUBLE	<p>If REORG is YES, the ratio of the number of imperfectly chunked LOBs to the total number of rows or LOBs in the table space or partition, expressed as a percentage. Otherwise null.</p> <p>If the ratio of the number of imperfectly chunked LOBs to the total number of rows or LOBs in the table space or partition does not exceed the value of <i>RRTDisorgLOBPct</i>, this value is null</p>
RRTDATSPRAT	DOUBLE	<p>If REORG is YES, the ratio of the number of SPACE allocated and the space used, exceed the value specified by the <i>RRTDataSpaceRat</i> threshold. Otherwise null.</p>
RRTMASSDELETE	INTEGER	<p>If REORG is YES, and the table space is a segmented table space or LOB table space, the number of mass deletes since the last REORG or LOAD REPLACE. If REORG is YES, and the table space is nonsegmented, the number of dropped tables since the last REORG or LOAD REPLACE. Otherwise null.</p> <p>If the number of dropped tables since the last REORG or LOAD REPLACE does not exceed the value specified for <i>RRTMassDelLimit</i>, this value is null.</p>
RRTINDREF	DOUBLE	<p>If REORG is YES, the ratio of the total number of overflow records that were created since the last REORG or LOAD REPLACE to the total number of rows or LOBs in the table space or partition, expressed as a percentage. Otherwise null.</p> <p>If the ratio of the total number of overflow records that were created since the last REORG or LOAD REPLACE to the total number of rows or LOBs does not exceed the value specified for <i>RRTIndRef</i>, this value is null.</p>
RRIINSERTSPCT	DOUBLE	<p>If REORG is YES, the ratio of the total number of insert operations since the last REORG to the total number of index entries in the index space or partition, expressed as a percentage. Otherwise null.</p> <p>If the ratio of the total number of insert operations since the last REORG to the total number of index entries does not exceed the value specified for <i>RRIInsertsPct</i>, this value is null.</p>

Table 155. Result set row for second DSNACCOX result set (continued)

Column name	Data type ^{"1" on page 879}	Description
RRINSERTSABS	INTEGER	<p>If REORG is YES, the total number of insert operations since the last REORG. Otherwise null.</p> <p>If the total number of insert operations since the last REORG does not exceed the value specified for <i>RRTInsertsAbs</i>, this value is null.</p>
RRIDELETESPCT	DOUBLE	<p>If REORG is YES, the ratio of the total number of delete operations since the last REORG to the total number of index entries in the index space or partition, expressed as a percentage. Otherwise null.</p> <p>If the ratio of the total number of delete operations since the last REORG to the total number of index entries does not exceed the value specified for <i>RRIDeletesPct</i>, this value is null.</p>
RRIDELETABS	INTEGER	<p>If REORG is YES, the total number of delete operations since the last REORG. Otherwise null.</p> <p>If the total number of delete operations since the last REORG does not exceed the value specified for <i>RRTDeletesAbs</i>, this value is null.</p>
RRIAPPINSPCT	DOUBLE	<p>If REORG is YES, the ratio of the number of index entries that were inserted since the last REORG, REBUILD INDEX, or LOAD REPLACE that had a key value greater than the maximum key value in the index space or partition, to the number of index entries in the index space or partition, expressed as a percentage. Otherwise null.</p> <p>If the ratio of the number of index entries that were inserted, which had a key value greater than the maximum key value, to the number of index entries does not exceed the value specified for <i>RRIAppendInsertPct</i>, this value is null.</p>
RRIPSDDEL PCT	DOUBLE	<p>If REORG is YES, the ratio of the number of index entries that were pseudo-deleted (the RID entry was marked as deleted) since the last REORG, REBUILD INDEX, or LOAD REPLACE to the number of index entries in the index space or partition, expressed as a percentage. Otherwise null.</p> <p>If the ratio of the number of index entries that were pseudo-deleted since the last REORG, REBUILD INDEX, or LOAD REPLACE to the number of index entries does not exceed the value specified for <i>RRIPseudoDeletePct</i>, this value is null.</p>

Table 155. Result set row for second DSNACCOX result set (continued)

Column name	Data type ^{"1" on page 879}	Description
RRIMASSDELETE	INTEGER	<p>If REORG is YES, the number of mass deletes from the index space or partition since the last REORG, REBUILD, or LOAD REPLACE. Otherwise null.</p> <p>If the number of mass deletes from the index space or partition since the last REORG, REBUILD, or LOAD REPLACE does not exceed the value specified for <i>RRIMassDelLimit</i>, this value is null.</p>
RRILEAF	DOUBLE	<p>If REORG is YES, the ratio of the number of index page splits that occurred since the last REORG, REBUILD INDEX, or LOAD REPLACE in which the higher part of the split page was far from the location of the original page, to the total number of active pages in the index space or partition, expressed as a percentage. Otherwise null.</p> <p>If the ratio of the number of index page splits that occurred since the last REORG, REBUILD INDEX, or LOAD REPLACE to the total number of active pages does not exceed the value specified for <i>RRILeafLimit</i>, this value is null.</p>
RRINUMLEVELS	INTEGER	<p>If REORG is YES, the number of levels in the index tree that were added or removed since the last REORG, REBUILD INDEX, or LOAD REPLACE. Otherwise null.</p> <p>If the number of levels in the index tree that were added or removed does not exceed the value specified for <i>RRINumLevelsLimit</i>, this value is null.</p>
STATSLASTTIME	TIMESTAMP	Timestamp of the last RUNSTATS on the object. Null if RUNSTATS was never run, or if the last RUNSTATS execution was unknown.
SRTINSDELUPDPCT	DOUBLE	<p>If RUNSTATS is YES, the ratio of the total number of insert, update, and delete operations since the last RUNSTATS on a table space or partition, to the total number of rows or LOBs in the table space or partition, expressed as a percentage. Otherwise null.</p> <p>If the ratio of the total number of insert, update, and delete operations since the last RUNSTATS to the total number of rows or LOBs does not exceed the value specified for <i>SRTInsDelUpdPct</i>, this value is null.</p>

Table 155. Result set row for second DSNACCOX result set (continued)

Column name	Data type ^{"1" on page 879}	Description
SRTINSDELUPDABS	INTEGER	<p>If RUNSTATS is YES, the total number of insert, update, and delete operations since the last RUNSTATS on a table space or partition. Otherwise null.</p> <p>If the total number of insert, update, and delete operations since the last RUNSTATS does not exceed the value specified for <i>SRTInsDelUpdAbs</i>, this value is null.</p>
SRTMASSDELETE	INTEGER	<p>If RUNSTATS is YES, the number of mass deletes from the table space or partition since the last REORG or LOAD REPLACE. Otherwise null.</p> <p>If the number of mass deletes from the table space or partition since the last REORG or LOAD REPLACE does not exceed the value specified for <i>SRTMassDelLimit</i>, this value is null.</p>
SRIINSDELPCT	DOUBLE	<p>If RUNSTATS is YES, the ratio of the total number of insert and delete operations since the last RUNSTATS on the index space or partition, to the total number of index entries in the index space or partition, expressed as a percentage. Otherwise null.</p> <p>If the ratio of the total number of insert and delete operations since the last RUNSTATS, to the total number of index entries does not exceed the value specified for <i>SRIInsDelPct</i>, this value is null.</p>
SRIINSDELABS	INTEGER	<p>If RUNSTATS is YES, the number insert and delete operations since the last RUNSTATS on the index space or partition. Otherwise null.</p> <p>If the total number of insert, update, and delete operations since the last RUNSTATS does not exceed the value specified for , this value is null.</p>
SRIMASSDELETE	INTEGER	<p>If RUNSTATS is YES, the number of mass deletes from the index space or partition since the last REORG, REBUILD INDEX, or LOAD REPLACE. Otherwise, this value is null.</p> <p>If the number of mass deletes does not exceed the value specified for <i>SRIMassDelete</i>, this value is null.</p>
TOTALEXTENTS	SMALLINT	<p>If EXTENTS is YES, the number of physical extents in the table space, index space, or partition. Otherwise, this value is null.</p> <p>If the number of physical extents does not exceed the value specified for <i>ExtentLimit</i>, this value is null.</p>

Table 155. Result set row for second DSNACCOX result set (continued)

Column name	Data type ¹ on page 879	Description
RRIEMPTYLIMIT	DOUBLE	<p>This column is returned when the function level is function level 500 or higher. Otherwise, this column is returned only when the value of <i>RRIEmptyLimit</i> contains a plus (+) sign.</p> <p>If <i>ObjectType</i> is IX and REORG is YES, the ratio of the total number of leaf pages since the last REORG to the total number of pseudo-empty pages in the index space or partition, expressed as a percentage. Otherwise null.</p> <p>If the ratio of the total number leaf pages since the last REORG to the total number of pseudo-empty pages does not exceed the value specified for the <i>RRIEmptyLimit</i> input parameter, this value is null.</p>
RRHASHOVRFLWRAT	DOUBLE	<p>This column is returned when the function level is function level 500 or higher. Otherwise, this column is returned only when the value of <i>RRIEmptyLimit</i> contains a plus (+) sign.</p> <p>If REORG is YES, the ratio of Hash Access overflow index entries to the total number of rows, expressed as a percentage. Otherwise null.</p> <p>If the ratio of Hash Access overflow index entries to the total number of rows does not exceed the value specified for <i>RRTHashOvrFlwRatio</i> or meet the criteria requirement, this value is null.</p>
RRTPBGSPACEPCT	DOUBLE	Reserved for future use.

1. Columns that are not marked as NOT NULL can contain null values.



Related tasks

- [Maintaining data organization and statistics \(Db2 Performance\)](#)
- [Setting up your system for real-time statistics \(Db2 Performance\)](#)
- [Implementing Db2 stored procedures \(Stored procedures provided by Db2\)](#)

Related reference

- [REORG TABLESPACE \(Db2 Utilities\)](#)
- [REORG INDEX \(Db2 Utilities\)](#)
- [RUNSTATS \(Db2 Utilities\)](#)
- [CREATE DATABASE statement](#)
- The CREATE DATABASE statement defines a Db2 database at the current server.
- [CREATE TABLESPACE statement](#)
- The CREATE TABLESPACE statement defines a table space at the current server. The type of table space depends on the keywords specified.
- [SYSTABLESPACESTATS catalog table](#)
- The SYSTABLESPACESTATS table contains real time statistics for table spaces. The schema is SYSIBM.
- [SYSINDEXSPACESTATS catalog table](#)

The SYSINDEXSPACESTATS table contains real time statistics for index spaces. The schema is SYSIBM.

SYSTABLES_PROFILES catalog table

The SYSTABLES_PROFILES table contains one row for each profile that is associated with a table in SYSIBM.SYSTABLES. The schema is SYSIBM.

DSNACICS stored procedure

The CICS transaction invocation stored procedure (DSNACICS) invokes CICS server programs.

GUPT DSNACICS gives workstation applications a way to invoke CICS server programs while using TCP/IP as their communication protocol. The workstation applications use TCP/IP and Db2 Connect to connect to a Db2 for z/OS subsystem, and then call DSNACICS to invoke the CICS server programs.

The DSNACICS input parameters require knowledge of various CICS resource definitions with which the workstation programmer might not be familiar. For this reason, DSNACICS invokes the DSNACICX user exit routine. The system programmer can write a version of DSNACICX that checks and overrides the parameters that the DSNACICS caller passes. If no user version of DSNACICX is provided, DSNACICS invokes the default version of DSNACICX, which does not modify any parameters.

Environment

DSNACICS runs in a WLM-established stored procedure address space and uses the Resource Recovery Services attachment facility to connect to Db2.

If you use CICS Transaction Server for OS/390® Version 1 Release 3 or later, you can register your CICS system as a resource manager with recoverable resource management services (RRMS). When you do that, changes to Db2 databases that are made by the program that calls DSNACICS and the CICS server program that DSNACICS invokes are in the same two-phase commit scope. This means that when the calling program performs an SQL COMMIT or ROLLBACK, Db2 and RRS inform CICS about the COMMIT or ROLLBACK.

If the CICS server program that DSNACICS invokes accesses Db2 resources, the server program runs under a separate unit of work from the original unit of work that calls the stored procedure. This means that the CICS server program might deadlock with locks that the client program acquires.

Authorization

To execute the CALL statement, the owner of the package or plan that contains the CALL statement must have one or more of the following privileges:

- The EXECUTE privilege on stored procedure DSNACICS
- Ownership of the stored procedure
- SYSADM authority

The CICS server program that DSNACICS calls runs under the same user ID as DSNACICS. That user ID depends on the SECURITY parameter that you specify when you define DSNACICS.

The DSNACICS caller also needs authorization from an external security system, such as RACF, to use CICS resources.

Syntax

The following syntax diagram shows the SQL CALL statement for invoking this stored procedure.

Because the linkage convention for DSNACICS is GENERAL WITH NULLS, if you pass parameters in host variables, you need to include a null indicator with every host variable. Null indicators for input host variables must be initialized before you execute the CALL statement.

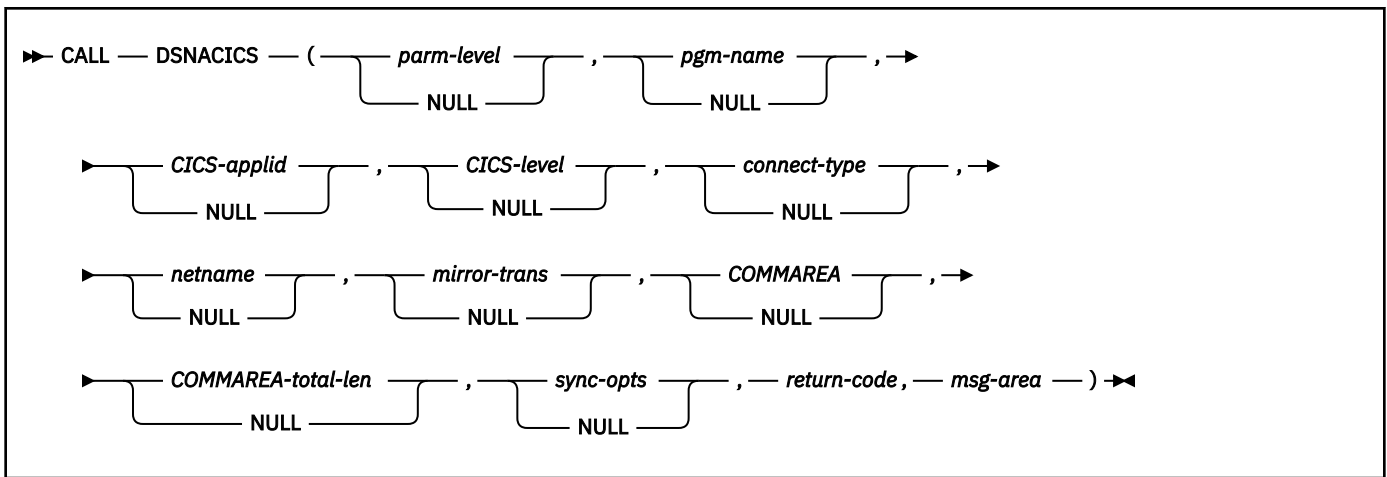

Option descriptions

parm-level

Specifies the level of the parameter list that is supplied to the stored procedure. This is an input parameter of type INTEGER. The value must be 1.

pgm-name

Specifies the name of the CICS program that DSNACICS invokes. This is the name of the program that the CICS mirror transaction calls, not the CICS transaction name.

This is an input parameter of type CHAR(8).

CICS-applid

Specifies the applid of the CICS system to which DSNACICS connects.

This is an input parameter of type CHAR(8).

CICS-level

Specifies the level of the target CICS subsystem:

1

The CICS subsystem is CICS for MVS/ESA Version 4 Release 1, CICS Transaction Server for OS/390 Version 1 Release 1, or CICS Transaction Server for OS/390 Version 1 Release 2.

2

The CICS subsystem is CICS Transaction Server for OS/390 Version 1 Release 3 or later.

This is an input parameter of type INTEGER.

connect-type

Specifies whether the CICS connection is generic or specific. Possible values are GENERIC or SPECIFIC.

This is an input parameter of type CHAR(8).

netname

If the value of *connection-type* is SPECIFIC, specifies the name of the specific connection that is to be used. This value is ignored if the value of *connection-type* is GENERIC.

This is an input parameter of type CHAR(8).

mirror-trans

Specifies the name of the CICS mirror transaction to invoke. This mirror transaction calls the CICS server program that is specified in the *pgm-name* parameter. *mirror-trans* must be defined to the CICS server region, and the CICS resource definition for *mirror-trans* must specify DFHMIRS as the program that is associated with the transaction.

If this parameter contains blanks, DSNACICS passes a mirror transaction parameter value of null to the CICS EXCI interface. This allows an installation to override the transaction name in various

CICS user-replaceable modules. If a CICS user exit routine does not specify a value for the mirror transaction name, CICS invokes CICS-supplied default mirror transaction CSMI.

This is an input parameter of type CHAR(4).

COMMAREA

Specifies the communication area (COMMAREA) that is used to pass data between the DSNACICS caller and the CICS server program that DSNACICS calls.

This is an input/output parameter of type VARCHAR(32704). In the length field of this parameter, specify the number of bytes that DSNACICS sends to the CICS server program.

commarea-total-len

Specifies the total length of the COMMAREA that the server program needs.

This is an input parameter of type INTEGER. This length must be greater than or equal to the value that you specify in the length field of the COMMAREA parameter and less than or equal to 32704. When the CICS server program completes, DSNACICS passes the server program's entire COMMAREA, which is *commarea-total-len* bytes in length, to the stored procedure caller.

sync-opts

Specifies whether the calling program controls resource recovery, using two-phase commit protocols that are supported by RRS. Possible values are:

1

The client program controls commit processing. The CICS server region does not perform a syncpoint when the server program returns control to CICS. Also, the server program cannot take any explicit syncpoints. Doing so causes the server program to abnormally terminate.

2

The target CICS server region takes a syncpoint on successful completion of the server program. If this value is specified, the server program can take explicit syncpoints.

When CICS has been set up to be an RRS resource manager, the client application can control commit processing using SQL COMMIT requests. Db2 for z/OS ensures that CICS is notified to commit any resources that the CICS server program modifies during two-phase commit processing.

When CICS has not been set up to be an RRS resource manager, CICS forces syncpoint processing of all CICS resources at completion of the CICS server program. This commit processing is not coordinated with the commit processing of the client program.

This option is ignored when *CICS-level* is 1. This is an input parameter of type INTEGER.

return-code

Return code from the stored procedure. Possible values are:

0

The call completed successfully.

12

The request to run the CICS server program failed. The *msg-area* parameter contains messages that describe the error.

This is an output parameter of type INTEGER.

msg-area

Contains messages if an error occurs during stored procedure execution. The first messages in this area are generated by the stored procedure. Messages that are generated by CICS or the DSNACICX user exit routine might follow the first messages. The messages appear as a series of concatenated, viewable text strings.

This is an output parameter of type VARCHAR(500).

User exit routine

DSNACICS always calls user exit routine DSNACICX. You can use DSNACICX to change the values of DSNACICS input parameters before you pass those parameters to CICS. If you do not supply your own

version of DSNACICX, DSNACICS calls the default DSNACICX, which modifies no values and does an immediate return to DSNACICS. The source code for the default version of DSNACICX is in member DSNASCIX in data set *prefix.SDSNSAMP*. The source code for a sample version of DSNACICX that is written in COBOL is in member DSNASCIO in data set *prefix.SDSNSAMP*.

Example

The following PL/I example shows the variable declarations and SQL CALL statement for invoking the CICS transaction that is associated with program CICSPGM1.

```

/*****
/* DSNACICS PARAMETERS */
*****/
DECLARE PARM_LEVEL BIN FIXED(31);
DECLARE PGM_NAME CHAR(8);
DECLARE CICS_APPLID CHAR(8);
DECLARE CICS_LEVEL BIN FIXED(31);
DECLARE CONNECT_TYPE CHAR(8);
DECLARE NETNAME CHAR(8);
DECLARE MIRROR_TRANS CHAR(4);
DECLARE COMMAREA_TOTAL_LEN BIN FIXED(31);
DECLARE SYNC_OPTS BIN FIXED(31);
DECLARE RET_CODE BIN FIXED(31);
DECLARE MSG_AREA CHAR(500) VARYING;

DECLARE1 COMMAREA BASED(P1),
3 COMMAREA_LEN BIN FIXED(15),
3 COMMAREA_INPUT CHAR(30),
3 COMMAREA_OUTPUT CHAR(100);

/*****
/* INDICATOR VARIABLES FOR DSNACICS PARAMETERS */
*****/
DECLARE 1 IND_VARS,
3 IND_PARM_LEVEL BIN FIXED(15),
3 IND_PGM_NAME BIN FIXED(15),
3 IND_CICS_APPLID BIN FIXED(15),
3 IND_CICS_LEVEL BIN FIXED(15),
3 IND_CONNECT_TYPE BINFIXED(15),
3 IND_NETNAME BIN FIXED(15),
3 IND_MIRROR_TRANSBIN FIXED(15),
3 IND_COMMAREA BIN FIXED(15),
3 IND_COMMAREA_TOTAL_LEN BIN FIXED(15),
3 IND_SYNC_OPTS BIN FIXED(15),
3 IND_RETCODE BIN FIXED(15),
3 IND_MSG_AREA BIN FIXED(15);

/*****
/* LOCAL COPY OF COMMAREA */
*****/
DECLARE P1 POINTER;
DECLARE COMMAREA_STG CHAR(130) VARYING;

/*****
/* ASSIGN VALUES TO INPUT PARAMETERS PARM_LEVEL, PGM_NAME,
/* MIRROR_TRANS, COMMAREA, COMMAREA_TOTAL_LEN, AND SYNC_OPTS.
/* SET THE OTHER INPUT PARAMETERS TO NULL. THE DSNACICX
/* USER EXIT MUST ASSIGN VALUES FOR THOSE PARAMETERS.
*****/
PARM_LEVEL = 1;
IND_PARM_LEVEL = 0;

PGM_NAME = 'CICSPGM1';
IND_PGM_NAME = 0;

MIRROR_TRANS = 'MIRT';
IND_MIRROR_TRANS = 0;

P1 = ADDR(COMMAREA_STG);
COMMAREA_INPUT = 'THIS IS THE INPUT FOR CICSPGM1';
COMMAREA_OUTPUT = ' ';
COMMAREA_LEN = LENGTH(COMMAREA_INPUT);
IND_COMMAREA = 0;

COMMAREA_TOTAL_LEN = COMMAREA_LEN + LENGTH(COMMAREA_OUTPUT);
IND_COMMAREA_TOTAL_LEN = 0;

```

```

SYNC_OPTS= 1;
IND_SYNC_OPTS = 0;

IND_CICS_APPLID= -1;
IND_CICS_LEVEL = -1;
IND_CONNECT_TYPE = -1;
IND_NETNAME = -1;
/*****/
/* INITIALIZE
OUTPUT PARAMETERS TO NULL. */
/*****/
IND_RETCODE = -1;
IND_MSG_AREA= -1;
/*****/
/* CALL DSNACICS TO INVOKE CICS1. */
/*****/
EXEC SQL
  CALL SYSPROC.DSNACICS(:PARM_LEVEL           :IND_PARM_LEVEL,
                       :PGM_NAME             :IND_PGM_NAME,
                       :CICS_APPLID          :IND_CICS_APPLID,
                       :CICS_LEVEL           :IND_CICS_LEVEL,
                       :CONNECT_TYPE         :IND_CONNECT_TYPE,
                       :NETNAME              :IND_NETNAME,
                       :MIRROR_TRANS         :IND_MIRROR_TRANS,
                       :COMMAREA_STG         :IND_COMMAREA,
                       :COMMAREA_TOTAL_LEN   :IND_COMMAREA_TOTAL_LEN,
                       :SYNC_OPTS            :IND_SYNC_OPTS,
                       :RET_CODE             :IND_RETCODE,
                       :MSG_AREA             :IND_MSG_AREA);

```

Output

DSNACICS places the return code from DSNACICS execution in the *return-code* parameter. If the value of the return code is non-zero, DSNACICS puts its own error messages and any error messages that are generated by CICS and the DSNACICX user exit routine in the *msg-area* parameter.

The *COMMAREA* parameter contains the COMMAREA for the CICS server program that DSNACICS calls. The *COMMAREA* parameter has a VARCHAR type. Therefore, if the server program puts data other than character data in the COMMAREA, that data can become corrupted by code page translation as it is passed to the caller. To avoid code page translation, you can change the COMMAREA parameter in the CREATE PROCEDURE statement for DSNACICS to VARCHAR(32704) FOR BIT DATA. However, if you do so, the client program might need to do code page translation on any character data in the COMMAREA to make it readable.

Restrictions

Because DSNACICS uses the distributed program link (DPL) function to invoke CICS server programs, server programs that you invoke through DSNACICS can contain only the CICS API commands that the DPL function supports.

Debugging

If you receive errors when you call DSNACICS, ask your system administrator to add a DSNDUMP DD statement in the startup procedure for the address space in which DSNACICS runs. The DSNDUMP DD statement causes Db2 to generate an SVC dump whenever DSNACICS issues an error message. 

Related information

[Db2 for z/OS Stored Procedures: Through the CALL and Beyond \(IBM Redbooks\)](#)

[CICSplex SM API commands \(CICS Transaction Server for z/OS\)](#)

DSNAIMS stored procedure

DSNAIMS is a stored procedure that allows Db2 applications to invoke IMS transactions and commands easily, without maintaining their own connections to IMS.

GUPI DSNAIMS uses the IMS Open Transaction Manager Access (OTMA) API to connect to IMS and to execute the transactions.

Environment

DSNAIMS runs in a WLM-established stored procedures address space. DSNAIMS requires Db2 with RRSF enabled and IMS version 7 or later with OTMA Callable Interface enabled.

To use a two-phase commit process, you must have IMS Version 8 with UQ70789 or later.

Authorization

To set up and run DSNAIMS, you must be authorized to perform the following steps:

1. Use the job DSNTIJIM to issue the CREATE PROCEDURE statement for DSNAIMS and to grant the execution of DSNAIMS to PUBLIC. DSNTIJIM is provided in the SDSNSAMP data set. You need to customize DSNTIJIM to fit the parameters of your system.
2. Ensure that the OTMA Callable Interface is initialized.

Syntax

The following syntax diagram shows the SQL CALL statement for invoking this stored procedure:

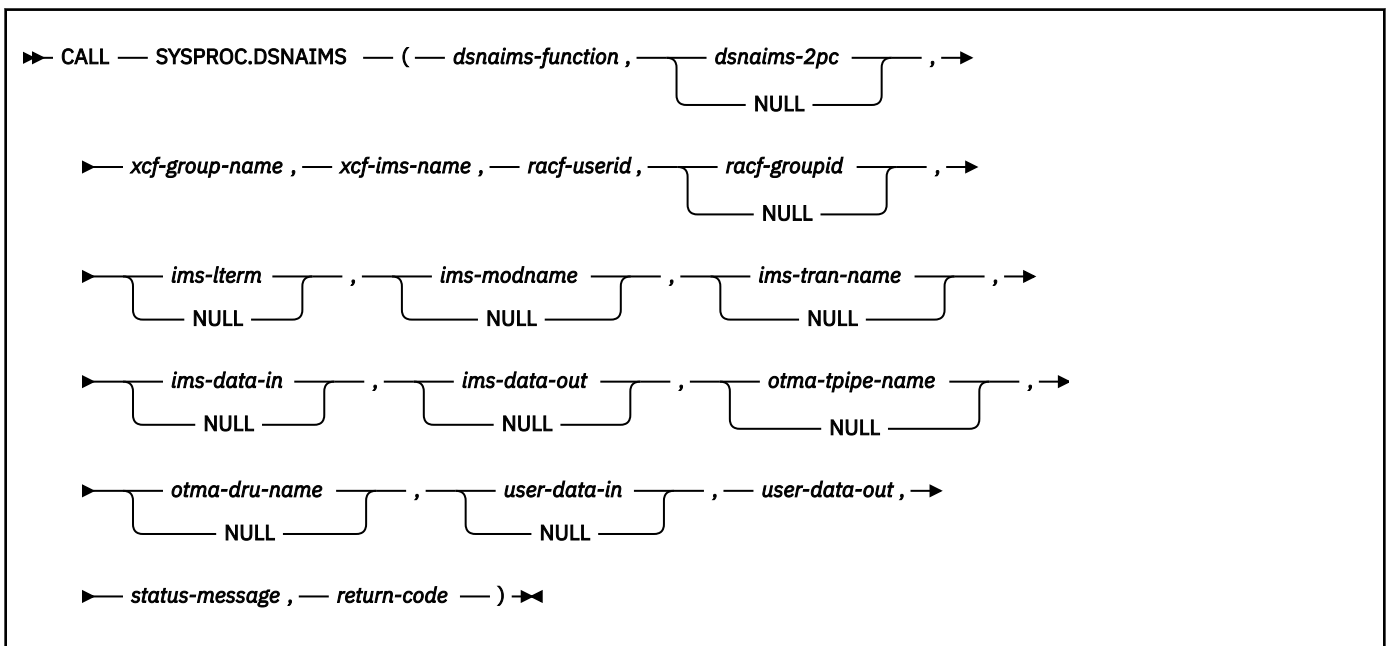

Option descriptions

dsnaims-function

A string that indicates whether the transaction is send-only, receive-only, or send-and-receive. Possible values are:

SENDRECV

Sends and receives IMS data. SENDRECV invokes an IMS transaction or command and returns the result to the caller. The transaction can be an IMS full function or a fast path transaction. SENDRECV does not support multiple iterations of a conversational transaction

SEND

Sends IMS data. SEND invokes an IMS transaction or command but does not receive IMS data. If result data exists, it can be retrieved with the RECEIVE function. A send-only transaction cannot be an IMS fast path transaction or a conversational transaction.

RECEIVE

Receives IMS data. The data can be the result of a transaction or a command that is initiated by the SEND function, or it can be an unsolicited output message from an IMS application. The RECEIVE function does not initiate an IMS transaction or command.

dsnaims-2pc

Specifies whether to use a two-phase commit process to perform the transaction syncpoint service. Possible values are Y or N. For N, commits and rollbacks that are issued by the IMS transaction do not affect commit and rollback processing in the Db2 application that invokes DSNAIMS. Furthermore, IMS resources are not affected by commits and rollbacks that are issued by the calling Db2 application. If you specify Y, you must also specify SENDRECV. To use a two-phase commit process, you must set the IMS control region parameter (RRS) to Y.

This parameter is optional. The default is N.

xcf-group-name

Specifies the XCF group name that the IMS OTMA joins. You can obtain this name by viewing the GRNAME parameter in IMS PROCLIB member DFSPBxxx or by using the IMS command /DISPLAY OTMA.

xcf-ims-name

Specifies the XCF member name that IMS uses for the XCF group. If IMS is not using the XRF or RSR feature, you can obtain the XCF member name from the OTMANM parameter in IMS PROCLIB member DFSPBxxx. If IMS is using the XRF or RSR feature, you can obtain the XCF member name from the USERVAR parameter in IMS PROCLIB member DFSPBxxx.

racf-userid

Specifies the RACF user ID that is used for IMS to perform the transaction or command authorization checking. This parameter is required if DSNAIMS is running APF-authorized. If DSNAIMS is running unauthorized, this parameter is ignored, and the EXTERNAL SECURITY setting for the DSNAIMS stored procedure definition determines the user ID that is used by IMS.

racf-groupid

Specifies the RACF group ID that is used for IMS to perform the transaction or command authorization checking. This field is used for stored procedures that are APF-authorized. It is ignored for other stored procedures.

ims-lterm

Specifies an IMS LTERM name that is used to override the LTERM name in the I/O program communication block of the IMS application program.

This field is used as an input and an output field:

- For SENDRECV, the value is sent to IMS on input and can be updated by IMS on output.
- For SEND, the parameter is IN only.
- For RECEIVE, the parameter is OUT only.

An empty or NULL value tells IMS to ignore the parameter.

ims-modname

Specifies the formatting map name that is used by the server to map output data streams, such as 3270 streams. Although this invocation does not have IMS MFS support, the input MODNAME can be used as the map name to define the output data stream. This name is an 8-byte message output descriptor name that is placed in the I/O program communication block. When the message is inserted, IMS places this name in the message prefix with the map name in the program communication block of the IMS application program.

For SENDRECV, the value is sent to IMS on input, and can be updated on output. For SEND, the parameter is IN only. For RECEIVE it is OUT only. IMS ignores the parameter when it is an empty or NULL value.

ims-tran-name

Specifies the name of an IMS transaction or command that is sent to IMS. If the IMS command is longer than eight characters, specify the first eight characters (including the "/" of the command). Specify the remaining characters of the command in the *ims-tran-name* parameter. If you use an empty or NULL value, you must specify the full transaction name or command in the *ims-data-in* parameter.

ims-data-in

Specifies the data that is sent to IMS. This parameter is required in each of the following cases:

- Input data is required for IMS.
- No transaction name or command is passed in *ims-tran-name*.
- The command is longer than eight characters.

This parameter is ignored for RECEIVE functions.

ims-data-out

Data that is returned after successful completion of the transaction. This parameter is required for SENDRECV and RECEIVE functions. The parameter is ignored for SEND functions.

The length of *ims-data-out* is 32000 bytes. If the data that is returned from IMS is greater than the length of *ims-data-out*, the data is truncated.

otma-tpipe-name

Specifies an 8-byte user-defined communication session name that IMS uses for the input and output data for the transaction or the command in a SEND or a RECEIVE function. If the *otma_tpipe_name* parameter is used for a SEND function to generate an IMS output message, the same *otma_pipe_name* must be used to retrieve output data for the subsequent RECEIVE function.

otma-dru-name

Specifies the name of an IMS user-defined exit routine, OTMA destination resolution user exit routine, if it is used. This IMS exit routine can format part of the output prefix and can determine the output destination for an IMS ALT_PCB output. If an empty or null value is passed, IMS ignores this parameter.

user-data-in

This optional parameter contains any data that is to be included in the IMS message prefix, so that the data can be accessed by IMS OTMA user exit routines (DFSYIOE0 and DFSYDRU0) and so that it can be tracked by IMS log records. IMS applications that run in dependent regions do not access this data. The specified user data is not included in the output message prefix. You can use this parameter to store input and output correlator tokens or other information. This parameter is ignored for RECEIVE functions.

user-data-out

On output, this field contains the *user-data-in* in the IMS output prefix. IMS user exit routines (DFSYIOE0 and DFSYDRU0) can also create *user-data-out* for SENDRECV and RECEIVE functions. The parameter is not updated for SEND functions.

The length of *user-data-out* is 1022 bytes. If the data that is returned from IMS is greater than the length of *user-data-out*, the data is truncated.

status-message

Indicates any error message that is returned from the transaction or command, OTMA, RRS, or DSNAIMS.

return-code

Indicates the return code that is returned for the transaction or command, OTMA, RRS, or DSNAIMS.

Examples

The following examples show how to call DSNAIMS.

Example 1: Sample parameters for executing an IMS command:

```
CALL SYSPROC.DSNAIMS("SENDRECV", "N", "IMS7GRP", "IMS7TMEM",
                    "IMSCLNM", "", "", "", "", "",
                    "/LOG Hello World.", ims_data_out, "", "", "",
                    user_out, error_message, rc)
```

Example 2: Sample parameters for executing an IMS IVTNO transaction:

```
CALL SYSPROC.DSNAIMS("SENDRECV", "N", "IMS7GRP", "IMS7TMEM",
                    "IMSCLNM", "", "", "", "", "",
                    "IVTNO    DISPLAY LAST1    ", ims_data_out
                    "", "", "", user_out, error_message, rc)
```

Example 3: Sample parameters for a send-only IMS transaction:

```
CALL SYSPROC.DSNAIMS("SEND", "N", "IMS7GRP", "IMS7TMEM",
                    "IMSCLNM", "", "", "", "", "",
                    "IVTNO    DISPLAY LAST1    ", ims_data_out,
                    "DSNAIPE", "", "", user_out, error_message, rc)
```

Example 4: Sample parameters for a receive-only IMS transaction:

```
CALL SYSPROC.DSNAIMS("RECEIVE", "N", "IMS7GRP", "IMS7TMEM",
                    "IMSCLNM", "", "", "", "", "",
                    "IVTNO    DISPLAY LAST1    ", ims_data_out,
                    "DSNAIPE", "", "", user_out, error_message, rc)
```

Connecting to multiple IMS subsystems with DSNAIMS

By default, DSNAIMS connects to only one IMS subsystem at a time. The first request to DSNAIMS determines to which IMS subsystem the stored procedure connects. DSNAIMS attempts to reconnect to IMS only in the following cases:

- IMS is restarted and the saved connection is no longer valid.
- WLM loads another DSNAIMS task.

To connect to multiple IMS subsystems simultaneously, perform the following steps:

1. Make a copy of the Db2-supplied job DSNTIJIM and customize it to your environment, as follows:

- Specify a separate WLM application environment name for each copy of the DSNTIJIM job that connects to a separate IMS subsystem.
- Change the procedure name from SYSPROC.DSNAIMS to another name, such as DSNAIMSB.

Do not change the EXTERNAL NAME option. Leave it as DSNAIMS.

2. Run the new job to create a second instance of the stored procedure.

3. To ensure that you connect to the intended IMS target, consistently use the XFC group and member names that you associate with each stored procedure instance. For example:

```
CALL SYSPROC.DSNAIMS("SENDRECV", "N", "IMS7GRP", "IMS7TMEM", ...)
CALL SYSPROC.DSNAIMSB("SENDRECV", "N", "IMS8GRP", "IMS8TMEM", ...)
```

GUPI

Related concepts

[OTMA C/I initialization](#)

Related information

[Db2 for z/OS Stored Procedures: Through the CALL and Beyond \(IBM Redbooks\)](#)

DSNAIMS2 stored procedure

DSNAIMS2 is a stored procedure that allows Db2 applications to invoke IMS transactions and commands easily, without maintaining their own connections to IMS. DSNAIMS2 includes multi-segment input support for IMS transactions.

GUPI DSNAIMS2 uses the IMS Open Transaction Manager Access (OTMA) API to connect to IMS and execute the transactions.

When you define the DSNAIMS2 stored procedure to your Db2 subsystem, you can use the name DSNAIMS in your application if you prefer. Customize DSNTIJI2 to define the stored procedure to your Db2 subsystem as DSNAIMS; however, the EXTERNAL NAME option must still be DSNAIMS2.

Environment

DSNAIMS2 runs in a WLM-established stored procedures address space. DSNAIMS2 requires Db2 with RRSAF enabled and IMS version 7 or later with OTMA Callable Interface enabled.

To use a two-phase commit process, you must have IMS Version 8 with UQ70789 or later.

Authorization

To set up and run DSNAIMS2, you must be authorized to perform the following steps:

1. Use the job DSNTIJI2 to issue the CREATE PROCEDURE statement for DSNAIMS2 and to grant the execution of DSNAIMS2 to PUBLIC. DSNTIJI2 is provided in the SDSNSAMP data set. You need to customize DSNTIJI2 to fit the parameters of your system.
2. Ensure that OTMA C/I is initialized.

Syntax

The following syntax diagram shows the SQL CALL statement for invoking this stored procedure:

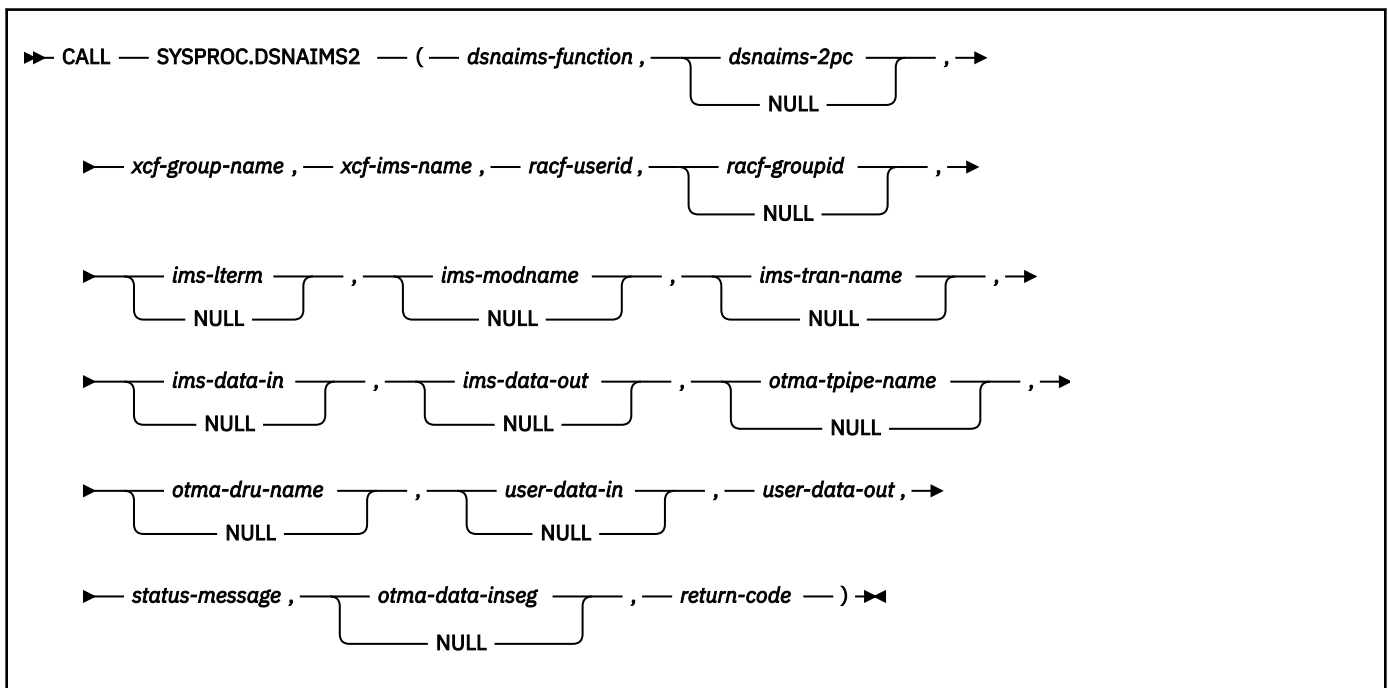

Option descriptions

dsnaims-function

A string that indicates whether the transaction is send-only, receive-only, or send-and-receive. Possible values are:

SENDRECV

Sends and receives IMS data. SENDRECV invokes an IMS transaction or command and returns the result to the caller. The transaction can be an IMS full function or a fast path. SENDRECV does not support multiple iterations of a conversational transaction

SEND

Sends IMS data. SEND invokes an IMS transaction or command, but does not receive IMS data. If result data exists, it can be retrieved with the RECEIVE function. A send-only transaction cannot be an IMS fast path transaction or a conversational transaction.

RECEIVE

Receives IMS data. The data can be the result of a transaction or command initiated by the SEND function or an unsolicited output message from an IMS application. The RECEIVE function does not initiate an IMS transaction or command.

dsnaims-2pc

Specifies whether to use a two-phase commit process to perform the transaction syncpoint service. Possible values are Y or N. For N, commits and rollbacks that are issued by the IMS transaction do not affect commit and rollback processing in the Db2 application that invokes DSNAIMS2. Furthermore, IMS resources are not affected by commits and rollbacks that are issued by the calling Db2 application. If you specify Y, you must also specify SENDRECV. To use a two-phase commit process, you must set the IMS control region parameter (RRS) to Y.

This parameter is optional. The default is N.

xcf-group-name

Specifies the XCF group name that the IMS OTMA joins. You can obtain this name by viewing the GRNAME parameter in IMS PROCLIB member DFSPBxxx or by using the IMS command /DISPLAY OTMA.

xcf-ims-name

Specifies the XCF member name that IMS uses for the XCF group. If IMS is not using the XRF or RSR feature, you can obtain the XCF member name from the OTMANM parameter in IMS PROCLIB member DFSPBxxx. If IMS is using the XRF or RSR feature, you can obtain the XCF member name from the USERVAR parameter in IMS PROCLIB member DFSPBxxx.

racf-userid

Specifies the RACF user ID that is used for IMS to perform the transaction or command authorization checking. This parameter is required if DSNAIMS2 is running APF-authorized. If DSNAIMS2 is running unauthorized, this parameter is ignored and the EXTERNAL SECURITY setting for the DSNAIMS2 stored procedure definition determines the user ID that is used by IMS.

racf-groupid

Specifies the RACF group ID that is used for IMS to perform the transaction or command authorization checking. This field is used for stored procedures that are APF-authorized. It is ignored for other stored procedures.

ims-lterm

Specifies an IMS LTERM name that is used to override the LTERM name in the I/O program communication block of the IMS application program.

This field is used as an input and an output field:

- For SENDRECV, the value is sent to IMS on input and can be updated by IMS on output.
- For SEND, the parameter is IN only.
- For RECEIVE, the parameter is OUT only.

An empty or NULL value tells IMS to ignore the parameter.

ims-modname

Specifies the formatting map name that is used by the server to map output data streams, such as 3270 streams. Although this invocation does not have IMS MFS support, the input MODNAME can be used as the map name to define the output data stream. This name is an 8-byte message output descriptor name that is placed in the I/O program communication block. When the message is inserted, IMS places this name in the message prefix with the map name in the program communication block of the IMS application program.

For SENDRECV, the value is sent to IMS on input, and can be updated on output. For SEND, the parameter is IN only. For RECEIVE it is OUT only. IMS ignores the parameter when it is an empty or NULL value.

ims-tran-name

Specifies the name of an IMS transaction or command that is sent to IMS. If the IMS command is longer than eight characters, specify the first eight characters (including the "/" of the command). Specify the remaining characters of the command in the *ims-tran-name* parameter. If you use an empty or NULL value, you must specify the full transaction name or command in the *ims-data-in* parameter.

ims-data-in

Specifies the data that is sent to IMS. This parameter is required in each of the following cases:

- Input data is required for IMS
- No transaction name or command is passed in *ims-tran-name*
- The command is longer than eight characters

This parameter is ignored when for RECEIVE functions.

ims-data-out

Data returned after successful completion of the transaction. This parameter is required for SENDRECV and RECEIVE functions. The parameter is ignored for SEND functions.

The length of *ims-data-out* is 32,000 bytes. If the data that is returned from IMS is greater than the length of *ims-data-out*, the data will be truncated.

otma-tpipe-name

Specifies an 8-byte user-defined communication session name that IMS uses for the input and output data for the transaction or the command in a SEND or a RECEIVE function. If the *otma_tpipe_name* parameter is used for a SEND function to generate an IMS output message, the same *otma_pipe_name* must be used to retrieve output data for the subsequent RECEIVE function.

otma-dru-name

Specifies the name of an IMS user-defined exit routine, OTMA destination resolution user exit routine, if it is used. This IMS exit routine can format part of the output prefix and can determine the output destination for an IMS ALT_PCB output. If an empty or null value is passed, IMS ignores this parameter.

user-data-in

This optional parameter contains any data that is to be included in the IMS message prefix, so that the data can be accessed by IMS OTMA user exit routines (DFSYIOE0 and DFSYDRU0) and can be tracked by IMS log records. IMS applications that run in dependent regions do not access this data. The specified user data is not included in the output message prefix. You can use this parameter to store input and output correlator tokens or other information. This parameter is ignored for RECEIVE functions.

user-data-out

On output, this field contains the *user-data-in* in the IMS output prefix. IMS user exit routines (DFSYIOE0 and DFSYDRU0) can also create *user-data-out* for SENDRECV and RECEIVE functions. The parameter is not updated for SEND functions.

The length of *user-data-out* is 1,022 bytes. If the data that is returned from IMS is greater than the length of *user-data-out*, the data will be truncated.

status-message

Indicates any error message that is returned from the transaction or command, OTMA, RRS, or DSNAIMS2.

otma-data-inseg

Specifies the number of segments followed by the lengths of the segments to be sent to IMS. All values should be separated by semicolons. This field is required to send multi-segment input to IMS. For single-segment transactions and commands, set the field to NULL, "0" or "0;"

return-code

Indicates the return code that is returned for the transaction or command, OTMA, RRS, or DSNAIMS2.

Examples

The following examples show how to call DSNAIMS2.

Example 1: Sample parameters for executing a multi-segment IMS transaction:

```
CALL SYSPROC.DSNAIMS2("SEND", "N", "IMS7GRP", "IMS7TMEM",  
    "IMSCLN", " ", " ", " ", " ", " ",  
    "PART 1ST SEGMENT FROM CI 2ND SEGMENT FROM CI ",  
    ims_data_out, " ", " ", " ", user_out, error_message,  
    "2;25;20", rc)
```

Example 2: Sample parameters for executing a single-segment IMS IVTNO transaction:

```
CALL SYSPROC.DSNAIMS2("SEND", "N", "IMS7GRP", "IMS7TMEM",  
    "IMSCLN", " ", " ", " ", " ", "IVTNO",  
    "DISPLAY LAST1", ims_data_out, " ", " ", " ",  
    user_out, error_message, NULL, rc)
```

Connecting to multiple IMS subsystems with DSNAIMS2

By default DSNAIMS2 connects to only one IMS subsystem at a time. The first request to DSNAIMS2 determines to which IMS subsystem the stored procedure connects. DSNAIMS2 attempts to reconnect to IMS only in the following cases:

- IMS is restarted and the saved connection is no longer valid
- WLM loads another DSNAIMS2 task

To connect to multiple IMS subsystems simultaneously, perform the following steps:

1. Make a copy of the Db2-supplied job DSNTIJI2 and customize it to your environment.
2. Change the procedure name from SYSPROC.DSNAIMS2 to another name, such as DSNAIMS2B.
3. Do not change the EXTERNAL NAME option. Leave it as DSNAIMS2.
4. Change the name of the stored procedure in the grant statement in job DSNTIJI2.
5. Run the new job to create a second instance of the stored procedure.
6. To ensure that you connect to the intended IMS target, consistently use the XFC group and member names that you associate with each stored procedure instance. For example:

```
CALL SYSPROC.DSNAIMS2("SENDRECV", "N", "IMS7GRP", "IMS7TMEM", ...)  
CALL SYSPROC.DSNAIMS2B("SENDRECV", "N", "IMS8GRP", "IMS8TMEM", ...)
```



Related concepts

[OTMA C/I initialization](#)

Related information

[Db2 for z/OS Stored Procedures: Through the CALL and Beyond \(IBM Redbooks\)](#)

DSNLEUSR stored procedure

The DSNLEUSR stored procedure is a sample stored procedure. Use this stored procedure to store encrypted values in the translated authorization ID (NEWAUTHID) and password fields of the SYSIBM.USERNAMES table.

GUPI You provide all the values for a SYSIBM.USERNAMES row as input to DSNLEUSR. DSNLEUSR encrypts the translated authorization ID and password values using 256-bit Advanced Encryption Standard (AES) encryption before it inserts the row into SYSIBM.USERNAMES.

Environment

DSNLEUSR has the following requirements:

- DSNLEUSR runs in a WLM-established stored procedure address space.
- z/OS Integrated Cryptographic Service Facility (ICSF) must be installed, configured, and active. The services that ICSF calls that are used by this stored procedure are CSNBCKM and CSNBENC.

Authorization

To execute the CALL DSNLEUSR statement, the owner of the package or plan that contains the CALL statement must have one or more of the following privileges:

- The EXECUTE privilege on the package for DSNLEUSR
- Ownership of the package
- PACKADM authority for the package collection
- SYSADM authority

The owner of the package or plan that contains the CALL statement must also have INSERT authority on SYSIBM.USERNAMES.

Syntax

The following syntax diagram shows the SQL CALL statement for invoking this stored procedure:

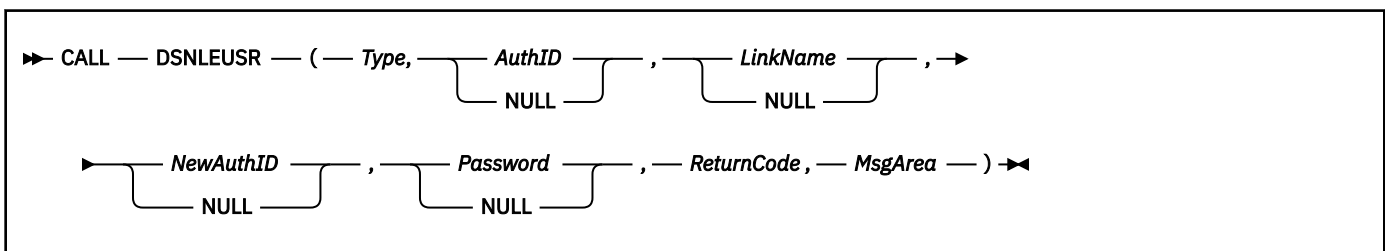

Option descriptions

Type

Specifies the value that is to be inserted into the TYPE column of SYSIBM.USERNAMES.

This is an input parameter of type CHAR(1).

AuthID

Specifies the value that is to be inserted into the AUTHID column of SYSIBM.USERNAMES.

This is an input parameter of type VARCHAR(128). If you specify a null value, DSNLEUSR does not insert a value for *AuthID*.

LinkName

Specifies the value that is to be inserted into the LINKNAME column of SYSIBM.USERNAMES.

This is an input parameter of type CHAR(8). Although the LINKNAME field of SYSIBM.USERNAMES is VARCHAR(24), this value is restricted to a maximum of 8 bytes.

If you specify a null value, DSNLEUSR does not insert a value for *LinkName* .

NewAuthID

Specifies the value that is to be inserted into the NEWAUTHID column of SYSIBM.USERNAMES.

This is an input parameter of type VARCHAR(54). The NEWAUTHID field is type VARCHAR(54) to allow for expansion during encryption.

If you specify a null value, DSNLEUSR does not insert a value for *NewAuthID*.

Password

Specifies the value that is to be inserted into the PASSWORD column of SYSIBM.USERNAMES.

If the input value to *Password* represents a password, the password value is restricted to 100 or fewer bytes. This applies even if the PASSWORD column of SYSIBM.USERNAMES is VARCHAR(255).

If you specify a null value, DSNLEUSR does not insert a value for *Password*.

ReturnCode

The return code from DSNLEUSR execution. Possible values are:

0

DSNLEUSR executed successfully.

8

The request to encrypt the translated authorization ID or password failed. *MsgArea* contains the following fields:

- An unformatted SQLCA that describes the error.
- A string that contains a DSNL045I message with the ICSF return code, the ICSF reason code, and the ICSF function that failed. The string immediately follows the SQLCA field and does not begin with a length field.

12

The insert operation for the SYSIBM.USERNAMES row failed. *MsgArea* contains an SQLCA that describes the error.

16

DSNLEUSR terminated because the Db2 subsystem is not in new-function mode. *MsgArea* contains an SQLCA that describes the error.

This is an output parameter of type INTEGER.

MsgArea

Contains information about DSNLEUSR execution. The information that is returned is described in the *ReturnCode* description.

This is an output parameter of type VARCHAR(500).

Example

The following COBOL example shows variable declarations and an SQL CALL for inserting a row into SYSIBM.USERNAMES with an encrypted translated authorization ID and an encrypted password.

```
WORKING-STORAGE SECTION.  
:  
*****  
* DSNLEUSR PARAMETERS *  
*****  
01 TYPE1                                PICTURE X(1) .  
01 AUTHID.  
   49 AUTHID-LN                          PICTURE S9(4) COMP .  
   49 AUTHID-DTA                          PICTURE X(128) .  
01 LINKNAME                              PICTURE X(8) .  
01 NEWAUTHID.  
   49 NEWAUTHID-LN                       PICTURE S9(4) COMP .
```

```

    49  NEWAUTHID-DTA          PICTURE X(54) .
01  PASSWORD1.
    49  PASSWORD1-LN PICTURE S9(4) COMP.
    49  PASSWORD1-DTA PICTURE X(100) .
01  RETURNCODE              PICTURE S9(9) COMP VALUE +0.
01  MSGAREA.
    49  MSGAREA-LN          PICTURE S9(4) COMP VALUE 500.
    49  MSGAREA-DTA        PICTURE X(500) VALUE SPACES.
*****
* INDICATOR VARIABLES.      *
*****
01  TYPE-IND                PICTURE S9(4) COMP-4.
01  AUTHID-IND              PICTURE S9(4) COMP-4.
01  LINKNAME-IND           PICTURE S9(4) COMP-4.
01  NEWAUTHID-IND          PICTURE S9(4) COMP-4.
01  PASSWORD-IND           PICTURE S9(4) COMP-4.
01  RETURNCODE-IND         PICTURE S9(4) COMP-4.
01  MSGAREA-IND            PICTURE S9(4) COMP-4.
PROCEDURE DIVISION.
?
*****
* SET VALUES FOR DSNLEUSR INPUT PARAMETERS.      *
* THE SET OF INPUT VALUES REPRESENTS A ROW THAT *
* DSNLEUSR INSERTS INTO SYSIBM.USERNAMES WITH    *
* ENCRYPTED NEWAUTHID AND PASSWORD VALUES.      *
*****
MOVE '0' TO TYPE1.
MOVE 0 TO AUTHID-LN.
MOVE SPACES TO AUTHID-DTA.
MOVE 'SYEC1B ' TO LINKNAME.
MOVE 4 TO NEWAUTHID-LN.
MOVE 'MYID' TO NEWAUTHID-DTA.
MOVE 6 TO PASSWORD1-LN.
MOVE 'MYPASS' TO PASSWORD1-DTA.
*****
* CALL DSNLEUSR *
*****
EXEC SQL
CALL SYSPROC.DSNLEUSR
(:TYPE1          :TYPE-IND,
 :AUTHID         :AUTHID-IND,
 :LINKNAME       :LINKNAME-IND,
 :NEWAUTHID      :NEWAUTHID-IND,
 :PASSWORD1      :PASSWORD-IND,
 :RETURNCODE     :RETURNCODE-IND,
 :MSGAREA        :MSGAREA-IND)
END-EXEC.

```

Output

If DSNLEUSR executes successfully, it inserts a row into SYSIBM.USERNAMES with encrypted values for the NEWAUTHID and PASSWORD columns and returns 0 for the *ReturnCode* parameter value. If DSNLEUSR does not execute successfully, it returns a non-zero value for the *ReturnCode* value and additional diagnostic information for the *MsgArea* parameter value. 

Related concepts

SQL communication area (SQLCA)

An SQLCA is a structure or collection of variables that is updated after each SQL statement executes. An application program that contains executable SQL statements must provide exactly one SQLCA, with a few exceptions.

Related reference

[z/OS Cryptographic Services Integrated Cryptographic Service Facility System Programmer's Guide](#)

DSNUTILS stored procedure (deprecated)

The DSNUTILS stored procedure enables you use the SQL CALL statement to execute Db2 utilities from a Db2 application program that specifies EBCDIC input.

Important: The DSNUTILS stored procedure is deprecated and replaced by DSNUTILU or DSNUTILV. It is best to convert existing callers of SYSIBM.SYSUTILS to use the SYSIBM.SYSUTILU or SYSIBM.SYSUTILV stored procedures instead.

When called, DSNUTILS performs the following actions:

- Dynamically allocates the specified data sets
- Creates the utility input (SYSIN) stream
- Invokes Db2 utilities (program DSNUTILB)
- Deletes all the rows that are currently in the created temporary table (SYSIBM.SYSPRINT)
- Captures the utility output stream (SYSPRINT) into a created temporary table (SYSIBM.SYSPRINT)
- Declares a cursor to select from SYSPRINT:

```
DECLARE SYSPRINT CURSOR WITH RETURN FOR
SELECT SEQNO, TEXT FROM SYSPRINT
ORDER BY SEQNO;
```

- Opens the SYSPRINT cursor and returns.

The calling program then fetches from the returned result set to obtain the captured utility output.

Environment for DSNUTILS

DSNUTILS must run in a WLM environment. The DSNWLM_UTIL environment is created for Db2 utilities stored procedures only. Stored procedures require special data set allocations.

The WLM core environment DSNWLM_UTIL. DSNWLM_UTIL is intended for the following Db2 utilities stored procedures only:

- DSNUTILV
- DSNUTILU
- DSNUTILS (deprecated)

If you plan to run other applications in this environment other than DSNUTILS or DSNUTILU, add the procedure and add the DCB information for SYSIN. For example:

```
//SYSIN DD UNIT=SYSDA,SPACE=(4000,(20,20),,,ROUND),
// DCB=(RECFM=V,LRECL=32708)
```

<i>Table 156. DSNWLM_UTIL environment</i>	
Property	Description
NUMTCB	1
APF authorized	Yes
Special DDs	<p>These DDs are required:</p> <ul style="list-style-type: none"> • SYSIN Allocates a work file for temporarily storing utility input statements. • SYSPRINT Allocates a work file for temporarily storing utility output messages. • RNPRIN01 Allocates a data set for messages from the sort program. Required only if you plan to invoke RUNSTATS and collect distribution statistics. • UTPRINT Allocates a data set for messages from the sort program. • DSSPRINT Allocates a data set for messages when making concurrent copies. <p>Example:</p> <pre>//UTPRINT DD SYSOUT=* //RNPRIN01 DD SYSOUT=* //DSSPRINT DD SYSOUT=* //SYSIN DD UNIT=SYSDA,SPACE=(4000,(20,20),,,ROUND) //SYSPRINT DD UNIT=SYSDA,SPACE=(4000,(20,20),,,ROUND)</pre>

Table 156. DSNWLM_UTILS environment (continued)

Property	Description
Other considerations	The STEPLIB needs to include DSN=prefix.SDSNEXIT or other library where the authorization exit modules (DSN3@ATH and DSN3@SGN) reside.

Installation job DSNTIJMV creates an address space proc called DSNWLMU for DSNWLM_UTILS. When the installation CLIST is customized, the name and library name of this proc are changed according to the Db2 subsystem name you specified on panel DSNTIPM in the field SUBSYSTEM NAME. For example, if you specified a subsystem name of VA1A then this proc will be named VA1AWLMU.

Authorization required for DSNUTILS

To execute the CALL statement, the owner of the package or plan that contains the CALL statement must have one or more of the following privileges on each package that the stored procedure uses:

- The EXECUTE privilege on the package for DSNUTILS
- Ownership of the package
- PACKADM authority for the package collection
- SYSADM authority

Then, to execute the utility, you must use a privilege set that includes the authorization to run the specified utility.

If you use RACF to protect JES resources, you must define a RACF group that is authorized to access those resources and add that RACF group name to the profile of the user ID that calls DSNUTILS.

Control statement for DSNUTILS

DSNUTILS dynamically allocates the specified data sets. Any utility that requires a sort must include the SORTDEVT keyword in the utility control statement, and optionally, the SORTNUM keyword.

If the DSNUTILS stored procedure invokes a new utility, refer to [Table 157 on page 897](#) for information about the default data dispositions that are specified for dynamically allocated data sets. This table lists the DD name that is used to identify the data set and the default dispositions for the data set by utility.

Table 157. Data dispositions for dynamically allocated data sets

DD name	CHECK DATA	CHECK INDEX or CHECK LOB	COPY	COPY-TOCOPY	LOAD	MERGE-COPY	REBUILD INDEX	REORG INDEX	REORG TABLE-SPACE	UNLOAD
SYSREC	ignored	ignored	ignored	ignored	OLD KEEP KEEP	ignored	ignored	ignored	NEW CATLG CATLG	NEW CATLG CATLG
SYSDISC	ignored	ignored	ignored	ignored	NEW CATLG CATLG	ignored	ignored	ignored	NEW CATLG CATLG	ignored
SYSPUNCH	ignored	ignored	ignored	ignored	ignored	ignored	ignored	ignored	NEW CATLG CATLG	NEW CATLG CATLG
SYSCOPY	ignored	ignored	NEW CATLG CATLG	ignored	NEW CATLG CATLG	NEW CATLG CATLG	ignored	ignored	NEW CATLG CATLG	ignored
SYSCOPY2	ignored	ignored	NEW CATLG CATLG	NEW CATLG CATLG	NEW CATLG CATLG	NEW CATLG CATLG	ignored	ignored	NEW CATLG CATLG	ignored

Table 157. Data dispositions for dynamically allocated data sets (continued)

DD name	CHECK DATA	CHECK INDEX or CHECK LOB	COPY	COPY-TOCOPY	LOAD	MERGE-COPY	REBUILD INDEX	REORG INDEX	REORG TABLE-SPACE	UNLOAD
SYSRCPY1	ignored	ignored	NEW CATLG CATLG	NEW CATLG CATLG	NEW CATLG CATLG	NEW CATLG CATLG	ignored	ignored	NEW CATLG CATLG	ignored
SYSRCPY2	ignored	ignored	NEW CATLG CATLG	NEW CATLG CATLG	NEW CATLG CATLG	NEW CATLG CATLG	ignored	ignored	NEW CATLG CATLG	ignored
SYSUT1	NEW DELETE CATLG	NEW DELETE CATLG	ignored	ignored	NEW DELETE CATLG	ignored	NEW DELETE CATLG	NEW CATLG CATLG	NEW DELETE CATLG	ignored
SORTOUT	NEW DELETE CATLG	ignored	ignored	ignored	NEW DELETE CATLG	ignored	ignored	ignored	NEW DELETE CATLG	ignored
SYSMAP	ignored	ignored	ignored	ignored	NEW CATLG CATLG	ignored	ignored	ignored	ignored	ignored
SYSERR	NEW CATLG CATLG	ignored	ignored	ignored	NEW CATLG CATLG	ignored	ignored	ignored	ignored	ignored
FILTER	ignored	ignored	NEW DELETE CATLG	ignored	ignored	ignored	ignored	ignored	ignored	ignored

If the DSNUTILS stored procedure restarts a current utility, refer to Table 158 on page 898 for information about the default data dispositions that are specified for dynamically-allocated data sets on RESTART. This table lists the DD name that is used to identify the data set and the default dispositions for the data set by utility.

Table 158. Data dispositions for dynamically allocated data sets on RESTART

DD name	CHECK DATA	CHECK INDEX or CHECK LOB	COPY	COPY-TOCOPY	LOAD	MERGE-COPY	REBUILD INDEX	REORG INDEX	REORG TABLE-SPACE	UNLOAD
SYSREC	ignored	ignored	ignored	ignored	OLD KEEP KEEP	ignored	ignored	ignored	MOD CATLG CATLG	MOD CATLG CATLG
SYSDISC	ignored	ignored	ignored	ignored	MOD CATLG CATLG	ignored	ignored	ignored	MOD CATLG CATLG	ignored
SYSPUNCH	ignored	ignored	ignored	ignored	ignored	ignored	ignored	ignored	MOD CATLG CATLG	MOD CATLG CATLG
SYSCOPY	ignored	ignored	MOD CATLG CATLG	ignored	MOD CATLG CATLG	MOD CATLG CATLG	ignored	ignored	MOD CATLG CATLG	ignored
SYSCOPY2	ignored	ignored	MOD CATLG CATLG	MOD CATLG CATLG	MOD CATLG CATLG	MOD CATLG CATLG	ignored	ignored	MOD CATLG CATLG	ignored
SYSRCPY1	ignored	ignored	MOD CATLG CATLG	MOD CATLG CATLG	MOD CATLG CATLG	MOD CATLG CATLG	ignored	ignored	MOD CATLG CATLG	ignored
SYSRCPY2	ignored	ignored	MOD CATLG CATLG	MOD CATLG CATLG	MOD CATLG CATLG	MOD CATLG CATLG	ignored	ignored	MOD CATLG CATLG	ignored
SYSUT1	MOD DELETE CATLG	MOD DELETE CATLG	ignored	ignored	MOD DELETE CATLG	ignored	MOD DELETE CATLG	MOD CATLG CATLG	MOD DELETE CATLG	ignored
SORTOUT	MOD DELETE CATLG	ignored	ignored	ignored	MOD DELETE CATLG	ignored	ignored	ignored	MOD DELETE CATLG	ignored

Table 158. Data dispositions for dynamically allocated data sets on RESTART (continued)

DD name	CHECK DATA	CHECK INDEX or CHECK LOB	COPY	COPY-TOCOPY	LOAD	MERGE-COPY	REBUILD INDEX	REORG INDEX	REORG TABLE-SPACE	UNLOAD
SYSMAP	ignored	ignored	ignored	ignored	MOD CATLG CATLG	ignored	ignored	ignored	ignored	ignored
SYSERR	MOD CATLG CATLG	ignored	ignored	ignored	MOD CATLG CATLG	ignored	ignored	ignored	ignored	ignored
FILTER	ignored	ignored	MOD DELETE CATLG	ignored	ignored	ignored	ignored	ignored	ignored	ignored

DSNUTILS stored procedure syntax diagram

The following syntax diagram shows the SQL CALL statement for invoking utilities as a stored procedure. Because the linkage convention for DSNUTILS is GENERAL, you cannot pass null values for input parameters. For character parameters that you are not using, specify an empty string ('').

```

▶▶ CALL — DSNUTILS — ( — utility-id , restart , utstmt , retcode — , — utility-name —▶
    ▶▶ , recdsn , recdevt , recspace — , discdsn , discdevt , discspace — , pnchdsn , pnchdevt , pnchspace —▶
    ▶▶ , copydsn1 , copydevt1 , copyspace1 — , copydsn2 , copydevt2 , copyspace2 —▶
    ▶▶ , rcpydsn1 , rcpydevt1 , rcpyospace1 — , rcpydsn2 , rcpydevt2 , rcpyospace2 —▶
    ▶▶ , workdsn1 , workdevt1 , workspace1 — , workdsn2 , workdevt2 , workspace2 —▶
    ▶▶ , mapdsn , mapdevt , mapspace — , errdsn , errdevt , errspace — , filtrdsn , filtrdevt , filtrspace — ) ▶▶

```

DSNUTILS option descriptions

utility-id

Specifies a unique identifier for this utility within Db2.

This is an input parameter of type VARCHAR(16) in EBCDIC.

restart

Specifies whether Db2 is to restart a current utility, and, if so, at what point the utility is to be restarted.

restart is an input parameter of type VARCHAR(8) in Unicode UTF-8, which must be translatable to allowable EBCDIC characters. Specify one of the following values for this parameter:

NO or **null**

Indicates that the utility job is new, not a restart. No other utility with the same utility identifier (UID) can exist.

The **default** is null.

CURRENT

Restarts the utility at the last commit point.

PHASE

Restarts the utility at the beginning of the currently stopped phase. Use the DISPLAY UTILITY to determine the currently stopped phase.

PREVIEW

Executes in PREVIEW mode the utility control statements that follow. While in PREVIEW mode, Db2 parses all utility control statements for syntax errors, but normal utility execution does not take place. If the syntax is valid, Db2 expands all LISTDEF lists and TEMPLATE data set name expressions that appear in SYSIN and prints the results to the SYSPRINT data set. Db2 evaluates and expands all LISTDEF definitions into an actual list of table spaces or index spaces. Db2 also evaluates TEMPLATE data set name expressions into actual data set names through variable substitution. Db2 also expands lists from the SYSLISTD DD and TEMPLATE data set name expressions from the SYSTEMPL DD that is referenced by a utility invocation.

Absence of the PREVIEW keyword turns off preview processing with one exception. The absence of this keyword does not override the PREVIEW JCL parameter which, if specified, remains in effect for the entire job step.

This option is identical to the PREVIEW JCL parameter.

utstmt

Specifies the utility control statements.

This is an input parameter of type VARCHAR(32704) in EBCDIC.

retcode

Specifies the utility highest return code.

This is an output parameter of type INTEGER.

utility-name

Specifies the utility that you want to invoke.

This is an input parameter of type VARCHAR(20) in EBCDIC.

Because DSNUTILS allows only a single utility here, dynamic support of data set allocation is limited. Specify only a single utility that requires data set allocation in the *utstmt* parameter.

Select the utility name from the following list:

ANY^{“1” on page 901}

CHECK DATA

CHECK INDEX

CHECK LOB

COPY

COPYTOCOPY

DIAGNOSE

LOAD

MERGECOPY

MODIFY RECOVERY

MODIFY STATISTICS

QUIESCE

REBUILD INDEX

RECOVER

REORG INDEX

REORG LOB

REORG TABLESPACE

REPAIR

REPORT RECOVERY

REPORT TABLESPACESET

RUNSTATS INDEX

RUNSTATS TABLESPACE

STOSPACE

UNLOAD

1. Use ANY to indicate that TEMPLATE dynamic allocation is to be used. This value suppresses the dynamic allocation that is normally performed by DSNUTILS.

Recommendation: Invoke DSNUTILS with a *utility-name* of ANY and omit all of the xxxdsn, xxxdevt, and xxxspace parameters. Use TEMPLATE statements to allocate the data sets.

When you use TEMPLATE, utilities attempt to close and deallocate data sets when the utilities complete. However, under some circumstances, utilities cannot deallocate data sets. Under those circumstances, take one of the following sets of actions:

- If you want to terminate a utility after a failure:
 1. Use the TERM UTIL command to terminate the failing utility.
 2. Refresh the WLM environment in one of the following ways:

- Submit the VARY command:

```
VARY WLM,APPLENV=xxx,REFRESH
```

- Call the WLM_REFRESH stored procedure.

When you terminate the utility, Db2 deletes the data sets that are needed by the utility.

- If you want to restart a utility after a failure:
 1. Specify DISP (NEW,CATLG,CATLG) in your template for data sets that are needed by the utility.
 2. When the utility fails, refresh the WLM environment, but do not terminate the utility.

You need to delete the allocated data sets manually after the utility completes.

recdsn

Specifies the cataloged data set name that is required by LOAD for input, or by REORG TABLESPACE as the unload data set. *recdsn* is required for LOAD. It is also required for REORG TABLESPACE unless you also specified NOSYSREC or SHRLEVEL CHANGE. If you specify *recdsn*, the data set is allocated to the SYSREC DD name.

This is an input parameter of type VARCHAR(54) in EBCDIC.

If you specified the INDDN parameter for LOAD, the specified *ddname* value **must** be SYSREC.

If you specify the UNLDDN parameter for REORG TABLESPACE, the specified *ddname* value **must** be SYSREC.

recdevt

Specifies a unit address, a generic device type, or a user-assigned group name for a device on which the *recdsn* data set resides.

This is an input parameter of type CHAR(8) in EBCDIC.

recspace

Specifies the number of cylinders to use as the primary space allocation for the *recdsn* data set. The secondary space allocation is 10% of the primary space allocation.

This is an input parameter of type SMALLINT.

discdsn

Specifies the cataloged data set name that is used by LOAD as a discard data set to hold records not loaded, and by REORG TABLESPACE as a discard data set to hold records that are not reloaded. If you specify *discdsn*, the data set is allocated to the SYSDISC DD name.

This is an input parameter of type VARCHAR(54) in EBCDIC.

If you specify the DISCARDN parameter for LOAD or REORG TABLESPACE, the specified *ddname* value **must** be SYSDISC.

discdevt

Specifies a unit address, a generic device type, or a user-assigned group name for a device on which the *discdsn* data set resides.

This is an input parameter of type CHAR(8) in EBCDIC.

discspace

Specifies the number of cylinders to use as the primary space allocation for the *discdsn* data set. The secondary space allocation is 10% of the primary space allocation.

This is an input parameter of type SMALLINT.

pnchdsn

Specifies the cataloged data set name that REORG TABLESPACE UNLOAD EXTERNAL or REORG TABLESPACE DISCARD uses to hold the generated LOAD utility control statements. If you specify a value for *pnchdsn*, the data set is allocated to the SYSPUNCH DD name.

This is an input parameter of type VARCHAR(54) in EBCDIC.

If you specify the PUNCHDDN parameter for REORG TABLESPACE, the specified *ddname* value **must** be SYSPUNCH.

pnchdevt

Specifies a unit address, a generic device type, or a user-assigned group name for a device on which the *pnchdsn* data set resides.

This is an input parameter of type CHAR(8) in EBCDIC.

pnchspace

Specifies the number of cylinders to use as the primary space allocation for the *pnchdsn* data set. The secondary space allocation is 10% of the primary space allocation.

This is an input parameter of type SMALLINT.

copydsn1

Specifies the name of the required target (output) data set, which is needed when you specify the COPY, COPYTOCOPY, or MERGECOPY utilities. It is optional for LOAD and REORG TABLESPACE. If you specify *copydsn1*, the data set is allocated to the SYSCOPY DD name.

This is an input parameter of type VARCHAR(54) in EBCDIC.

If you specify the COPYDDN parameter for COPY, COPYTOCOPY, MERGECOPY, LOAD, or REORG TABLESPACE, the specified *ddname1* value **must** be SYSCOPY.

copydevt1

Specifies a unit address, a generic device type, or a user-assigned group name for a device on which the *copydsn1* data set resides.

This is an input parameter of type CHAR(8) in EBCDIC.

copyspace1

Specifies the number of cylinders to use as the primary space allocation for the *copydsn1* data set. The secondary space allocation is 10% of the primary space allocation.

This is an input parameter of type SMALLINT.

copydsn2

Specifies the name of the cataloged data set that is used as a target (output) data set for the backup copy. It is optional for COPY, COPYTOCOPY, MERGECOPY, LOAD, and REORG TABLESPACE. If you specify *copydsn2*, the data set is allocated to the SYSCOPY2 DD name.

This is an input parameter of type VARCHAR(54) in EBCDIC.

If you specify the COPYDDN parameter for COPY, COPYTOCOPY, MERGECOPY, LOAD, or REORG TABLESPACE, the specified *ddname2* value **must** be SYSCOPY2.

copydevt2

Specifies a unit address, a generic device type, or a user-assigned group name for a device on which the *copydsn2* data set resides.

This is an input parameter of type CHAR(8) in EBCDIC.

copyspace2

Specifies the number of cylinders to use as the primary space allocation for the *copydsn2* data set. The secondary space allocation is 10% of the primary space allocation.

This is an input parameter of type SMALLINT.

rcpydsn1

Specifies the name of the cataloged data set that is required as a target (output) data set for the remote site primary copy. It is optional for COPY, COPYTOCOPY, LOAD, and REORG TABLESPACE. If you specify *rcpydsn1*, the data set is allocated to the SYSRCPY1 DD name.

This is an input parameter of type VARCHAR(54) in EBCDIC.

If you specified the RECOVERYDDN parameter for COPY, COPYTOCOPY, MERGECOPY, LOAD, or REORG TABLESPACE, the specified *ddname1* value **must** be SYSRCPY1.

rcpydevt1

Specifies a unit address, a generic device type, or a user-assigned group name for a device on which the *rcpydsn1* data set resides.

This is an input parameter of type CHAR(8) in EBCDIC.

rcpyspace1

Specifies the number of cylinders to use as the primary space allocation for the *rcpydsn1* data set. The secondary space allocation is 10% of the primary space allocation.

This is an input parameter of type SMALLINT.

rcpydsn2

Specifies the name of the cataloged data set that is required as a target (output) data set for the remote site backup copy. It is optional for COPY, COPYTOCOPY, LOAD, and REORG TABLESPACE. If you specify *rcpydsn2*, the data set is allocated to the SYSRCPY2 DD name.

This is an input parameter of type VARCHAR(54) in EBCDIC.

If you specify the RECOVERYDDN parameter for COPY, COPYTOCOPY, MERGECOPY, LOAD, or REORG TABLESPACE, the specified *ddname2* value **must** be SYSRCPY2.

rcpydevt2

Specifies a unit address, a generic device type, or a user-assigned group name for a device on which the *rcpydsn2* data set resides.

This is an input parameter of type CHAR(8) in EBCDIC.

rcpyspace2

Specifies the number of cylinders to use as the primary space allocation for the *rcpydsn2* data set. The secondary space allocation is 10% of the primary space allocation.

This is an input parameter of type SMALLINT.

workdsn1

Specifies the name of the cataloged data set that is required as a work data set for sort input and output. It is required for CHECK DATA, CHECK INDEX and REORG INDEX. It is also required for LOAD and REORG TABLESPACE unless you also specify the SORTKEYS keyword. It is optional for REBUILD INDEX. If you specify *workdsn1*, the data set is allocated to the SYSUT1 DD name.

This is an input parameter of type VARCHAR(54) in EBCDIC.

If you specify the WORKDDN parameter for CHECK DATA, CHECK INDEX, LOAD, REORG INDEX, REORG TABLESPACE, or REBUILD INDEX, the specified *ddname* value **must** be SYSUT1.

workdevt1

Specifies a unit address, a generic device type, or a user-assigned group name for a device on which the *workdsn1* data set resides.

This is an input parameter of type CHAR(8) in EBCDIC.

workspace1

Specifies the number of cylinders to use as the primary space allocation for the *workdsn1* data set. The secondary space allocation is 10% of the primary space allocation.

This is an input parameter of type SMALLINT.

workdsn2

Specifies the name of the cataloged data set that is required as a work data set for sort input and output. It is required for CHECK DATA. It is also required if you use REORG INDEX to reorganize non-unique type 1 indexes. It is required for LOAD or REORG TABLESPACE unless you also specify the SORTKEYS keyword. If you specify *workdsn2*, the data set is allocated to the SORTOUT DD name.

This is an input parameter of type VARCHAR(54) in EBCDIC.

If you specify the WORKDDN parameter for CHECK DATA, LOAD, REORG INDEX, or REORG TABLESPACE, the specified *ddname* value **must** be SORTOUT.

workdevt2

Specifies a unit address, a generic device type, or a user-assigned group name for a device on which the *workdsn2* data set resides.

This is an input parameter of type CHAR(8) in EBCDIC.

workspace2

Specifies the number of cylinders to use as the primary space allocation for the *workdsn2* data set. The secondary space allocation is 10% of the primary space allocation.

This is an input parameter of type SMALLINT.

mapdsn

Specifies the name of the cataloged data set that is required as a work data set for error processing during LOAD with ENFORCE CONSTRAINTS. It is optional for LOAD. If you specify *mapdsn*, the data set is allocated to the SYSMAP DD name.

This is an input parameter of type VARCHAR(54) in EBCDIC.

If you specify the MAPDDN parameter for LOAD, the specified *ddname* value **must** be SYSMAP.

mapdevt

Specifies a unit address, a generic device type, or a user-assigned group name for a device on which the *mapdsn* data set resides.

This is an input parameter of type CHAR(8).

mapspace

Specifies the number of cylinders to use as the primary space allocation for the *mapdsn* data set. The secondary space allocation is 10% of the primary space allocation.

This is an input parameter of type SMALLINT.

errdsn

Specifies the name of the cataloged data set that is required as a work data set for error processing. It is required for CHECK DATA, and it is optional for LOAD. If you specify *errdsn*, the data set is allocated to the SYSERR DD name.

This is an input parameter of type VARCHAR(54) in EBCDIC.

If you specify the ERRDDN parameter for CHECK DATA or LOAD, the specified *ddname* value **must** be SYSERR.

errdevt

Specifies a unit address, a generic device type, or a user-assigned group name for a device on which the *errdsn* data set resides.

This is an input parameter of type CHAR(8) in EBCDIC.

errspace

Specifies the number of cylinders to use as the primary space allocation for the *errdsn* data set. The secondary space allocation is 10% of the primary space allocation.

This is an input parameter of type SMALLINT.

filtrdsn

Specifies the name of the cataloged data set that is required as a work data set for error processing. It is optional for COPY CONCURRENT. If you specify *filtrdsn*, the data set is allocated to the FILTER DD name.

This is an input parameter of type VARCHAR(54) in EBCDIC.

If you specify the FILTERDDN parameter for COPY, the specified *ddname* value **must** be FILTER.

filtrdevt

Specifies a unit address, a generic device type, or a user-assigned group name for a device on which the *filtrdsn* data set resides.

This is an input parameter of type CHAR(8) in EBCDIC.

filterspace

Specifies the number of cylinders to use as the primary space allocation for the *filtrdsn* data set. The secondary space allocation is 10% of the primary space allocation.

This is an input parameter of type SMALLINT.

Modifying the WLM-established address space for DSNUTILS

Add DSSPRINT, SYSIN, and SYSPRINT to the JCL procedure for starting the WLM-established address space in which DSNUTILS runs.

Requirement: You must allocate SYSIN and SYSPRINT in the procedure to temporarily store utility input statements and utility output messages. If you plan to invoke RUNSTATS and collect distribution statistics, you also need to allocate RNPRIN01.

Use JCL similar to the following sample PROC:

```
//*****  
//*      JCL FOR RUNNING THE WLM-ESTABLISHED STORED PROCEDURES  
//*      ADDRESS SPACE  
//*      RGN      -- THE MVS REGION SIZE FOR THE ADDRESS SPACE.  
//*      DB2SSN   -- THE DB2 SUBSYSTEM NAME.  
//*      APPLENV  -- THE MVS WLM APPLICATION ENVIRONMENT  
//*              SUPPORTED BY THIS JCL PROCEDURE.  
//*  
//*      IMPORTANT: You must use the value 1 in this EXEC card:  
//*      IEFPROC EXEC PGM=DSNX9WLM,REGION=&RGN,TIME=NOLIMIT,  
//*      PARM='&DB2SSN,1,&APPLENV'  
//*  
//*****  
//DSNWLM  PROC RGN=0K,APPLENV=WLMENV1,DB2SSN=DSN  
//IEFPROC EXEC PGM=DSNX9WLM,REGION=&RGN,TIME=NOLIMIT,  
//      PARM='&DB2SSN,1,&APPLENV'  
//STEPLIB DD DISP=SHR,DSN=CEE.V!R!M!.SCEERUN  
//      DD DISP=SHR,DSN=DSN! !0.SDSNLOAD  
//UTPRINT DD SYSOUT=*  
//RNPRIN01 DD SYSOUT=*  
//DSSPRINT DD SYSOUT=*  
//SYSIN   DD UNIT=SYSDA,SPACE=(4000,(20,20),,,ROUND)  
//SYSPRINT DD UNIT=SYSDA,SPACE=(4000,(20,20),,,ROUND)
```

Sample program for calling DSNUTILS

Three example programs calling DSNUTILS are shipped in SDSNSAMP.

- DSNTTEJ6U: A DSNUTILS caller that uses PL/I. Job DSNTTEJ6U compiles, link-edits, binds, and runs sample PL/I program DSN8EPU, which invokes the DSNUTILS stored procedure to execute an utility.

- DSNTEJ6V: A DSNUTILS caller that uses C++. Job DSNTEJ6V compiles, link-edits, binds, and runs sample C++ program DSN8EE1, which invokes the DSNUTILS stored procedure to execute an utility.
- DSNTEJ80: A DSNUTILS caller that uses C and ODBC. You can use this sample to compile, pre-link, link-edit, and execute the sample application DSN8OIVP, which you can use to verify that your Db2 ODBC installation is correct.

DSNUTILS output

Db2 creates the result set according to the DECLARE statement that is shown under [Example of declaring a cursor to select from SYSPRINT](#).

Output from a successful execution of the DSNTEJ6U sample job or an equivalent job lists the specified parameters followed by the messages that are generated by the Db2 DIAGNOSE DISPLAY MEPL utility.

If DSNUTILB abends, the abend codes are returned as DSNUTILS return codes.

Related reference

[Db2 Sort for z/OS](#)

Related information

[DFSORT Application Programming Guide](#)

DSNUTILU stored procedure

Use the DSNUTILU stored procedure to run Db2 utilities from a Db2 application program.

Tip: Alternatively, you can use the DSNUTILV stored procedure, which also supports statements that are larger than 32 KB. DSNUTILV can run utility statements as large as 2 GB. For more information see [“DSNUTILV stored procedure”](#) on page 910.

When called, DSNUTILU performs the following actions:

- Translates the values that are specified for the *utility-id* and *restart* parameters to EBCDIC
- Creates the utility input stream (SYSIN) for utility control statements that are encoded in Unicode
- Invokes Db2 utilities by using DSNUTILB
- Deletes all the rows that are currently in the created temporary table (SYSIBM.SYSPRINT)
- Captures the utility output stream (SYSPRINT) into a created temporary table (SYSIBM.SYSPRINT)
- Declares a cursor to select from SYSPRINT:

```
DECLARE SYSPRINT CURSOR WITH RETURN FOR
  SELECT SEQNO, TEXT FROM SYSPRINT
  ORDER BY SEQNO;
```

- Opens the SYSPRINT cursor

The calling program then fetches rows from the returned result set to obtain the captured utility output.

The character set of the resulting utility SYPRINT output that is placed in the SYSIBM.SYSPRINT table is determined by the BIND PACKAGE statement for the DSNUTILU stored procedure. If the bind option ENCODING(EBCDIC) is specified, the SYSPRINT contents are in EBCDIC. If the bind option ENCODING(UNICODE) is specified, the SYSPRINT contents are in Unicode. The default installation job, DSNTIIRT, contains ENCODING(EBCDIC).

Environment for DSNUTILU

DSNUTILU must run in a WLM environment.

The WLM core environment DSNWLM_UTILS. DSNWLM_UTILS is intended for the following Db2 utilities stored procedures only:

- DSNUTILV

- DSNUTILU
- DSNUTILS (deprecated)

If you plan to run other applications in this environment, add the procedure and add the DCB information for SYSIN, as shown in the following example:

```
//SYSIN DD UNIT=SYSDA,SPACE=(4000,(20,20),,,ROUND),
// DCB=(RECFM=V,LRECL=32708)
```

For more information, see [Core WLM environments for Db2-supplied routines \(Db2 Installation and Migration\)](#).

The WLM-established address space for DSNUTILU

The JCL procedure for starting the WLM-established address space in which DSNUTILU runs requires DD statements for DSSPRINT, SYSIN, and SYSPRINT. The SYSIN and SYSPRINT DD statements must allocate workfiles that DSNUTILU can use to temporarily store utility input statements and utility output messages. If you plan to run RUNSTATS and collect distribution statistics, you also need to allocate a DD statement for RNPRIN01.

Db2 provides an address space procedure for DSNWLM_UTILS, which is the core WLM environment for DSNUTILU. That address space procedure is called DSNWLMU. For detailed information about DSNWLMU, see [Core WLM environments for Db2-supplied routines \(Db2 Installation and Migration\)](#).

Authorization required for DSNUTILU

To call the DSNUTILU stored procedure, the owner of the package or plan that contains the CALL statement must have one or more of the following privileges on each package that the stored procedure uses:

- The EXECUTE privilege on the package for DSNUTILU
- Ownership of the package
- PACKADM authority for the package collection
- SYSADM authority

Then, to execute the utility, you must use a privilege set that includes the authorization to run the specified utility.

If you use RACF to protect JES resources, you must define a RACF group that is authorized to access those resources and add that RACF group name to the profile of the user ID that calls DSNUTILU.

Utility control statements that are passed to DSNUTILU

Input data sets for the utility control statements can begin with the following Unicode characters:

- A Unicode UTF-8 blank (X'20')
- A Unicode UTF-8 dash (X'2D')
- Uppercase Unicode UTF-8 "A" through "Z" (X'41' through X'5A')

Any utility that requires a sort must include the SORTDEVT keyword in the utility control statement. Use of the SORTNUM keyword is optional.

Also, DSNUTILU does not dynamically allocate data sets. Use the TEMPLATE utility control statement to dynamically allocate data sets.

For more information, see:

[Utility control statements \(Db2 Utilities\)](#)
[DFSORT Application Programming Guide](#)
[Db2 Sort for z/OS](#)

DSNUTILU stored procedure syntax diagram

The following syntax diagram shows the SQL CALL statement for invoking utilities as a stored procedure.

```
► CALL — DSNUTILU — ( — utility-id, restart, utstmt, retcode — ) —◄
```

DSNUTILU option descriptions

utility-id

Specifies a unique identifier for this utility within Db2.

utility-id is an input parameter of type VARCHAR(16) in Unicode UTF-8, which must be translatable to the following allowable EBCDIC characters:

- A–Z (uppercase and lowercase)
- 0–9
- #, \$, @, ¢, !, ^, or period (.)

restart

Specifies whether Db2 is to restart a current utility, and, if so, at what point the utility is to be restarted.

restart is an input parameter of type VARCHAR(8) in Unicode UTF-8, which must be translatable to allowable EBCDIC characters. Specify one of the following values for this parameter:

NO or null

Indicates that the utility job is new and is not a restarted job. No other utility with the same utility identifier (UID) can exist.

The default is null.

CURRENT

Restarts the utility at the last commit point.

PHASE

Restarts the utility at the beginning of the currently stopped phase. Use the DISPLAY UTILITY command to determine the currently stopped phase.

PREVIEW

Executes the utility control statements that follow in preview mode.

In preview mode, Db2 parses all utility control statements for syntax errors, but normal utility execution does not occur. If the syntax is valid, Db2 expands all LISTDEF lists and TEMPLATE data set name expressions that are included in SYSIN and prints the results to the SYSPRINT data set. Db2 evaluates and expands all LISTDEF statements into a list of table spaces or index spaces. Db2 also evaluates TEMPLATE data set name expressions into data set names through variable substitution. Db2 also expands lists and data set name expressions from any LISTDEF libraries and TEMPLATE libraries that are referenced by a utility invocation.

If the PREVIEW keyword is omitted, preview processing is turned off with one exception. The absence of this keyword does not override the PREVIEW JCL parameter, which, if specified, remains in effect for the entire job step.

This option is identical to the PREVIEW JCL parameter.

For more information, see:

[Restarting an online utility \(Db2 Utilities\)](#)

[-DISPLAY UTILITY command \(Db2\) \(Db2 Commands\)](#)

[Executing statements in preview mode \(Db2 Utilities\)](#)

utstmt

Specifies the utility control statements.

utstmt is an input parameter of type VARCHAR(32704) in Unicode UTF-8. If the utility statement is not in Unicode UTF-8, Db2 converts it to UTF-8. Therefore, if you pass a utility control statement in another format, consider the [Possible consequences of character conversion \(Db2 Internationalization Guide\)](#).

retcode

Specifies the utility highest return code.

retcode is an output parameter of type INTEGER.

Terminating or restarting a utility with DSNUTILU

If you do not want to restart a utility after a failure, take the following actions:

1. Use the TERM UTIL command to terminate the failing utility.

When you terminate the utility, Db2 deletes the data sets that are needed by the utility.

2. Refresh the WLM environment in one of the following ways:

- Submit the VARY command:

```
VARY WLM,APPLENV=xxx,REFRESH
```

- Call the WLM_REFRESH stored procedure.

If you want to restart a utility after a failure, take the following actions:

1. When you run the utility, use a TEMPLATE utility control statement, and specify DISP (NEW,CATLG,CATLG) in your template for data sets that are needed by the utility.
2. When the utility fails, refresh the WLM environment, but do not terminate the utility.
3. After the utility completes, delete the allocated data sets manually.

For more information, see [“WLM_REFRESH stored procedure” on page 997](#).

Sample program for calling DSNUTILU

The following sample program calls DSNUTILU and is included in SDSNSAMP:

Job DSNTJ6R compiles, link-edits, binds, and runs sample C-language caller program DSN8ED8, which invokes the DSNUTILU stored procedure to execute a utility. DSN8ED8 can pass either a utility statement or the name of a data set that contains the utility statement.

For more information, see [Job DSNTJ6R \(Db2 Installation and Migration\)](#).

DSNUTILU output

Db2 creates the result set according to the DECLARE statement shown in [Example of declaring a cursor to select from SYSPRINT](#)

Output from a successful execution of the DSNTJ6R sample job or an equivalent job lists the specified parameters, followed by the messages that are generated by the Db2 DIAGNOSE DISPLAY MEPL utility.

For more information, see [DIAGNOSE \(Db2 Utilities\)](#).

DSNUTILV stored procedure

Use the DSNUTILV stored procedure to run Db2 utilities from a Db2 application program. DSNUTILV can run utility statements as large as 2 GB.

When called, DSNUTILV performs the following actions:

- Translates the values that are specified for the *utility-id* and *restart* parameters to EBCDIC
- Creates the utility input stream (SYSIN) for utility control statements that are encoded in Unicode
- Invokes Db2 utilities by using DSNUTILB
- Deletes all the rows that are currently in the created temporary table (SYSIBM.SYSPRINT)
- Captures the utility output stream (SYSPRINT) into a created temporary table (SYSIBM.SYSPRINT)
- Declares a cursor to select from SYSPRINT:

```
DECLARE SYSPRINT CURSOR WITH RETURN FOR
SELECT SEQNO, TEXT FROM SYSPRINT
ORDER BY SEQNO;
```

- Opens the SYSPRINT cursor

The calling program then fetches rows from the returned result set to obtain the captured utility output.

The character set of the resulting utility SYPRINT output that is placed in the SYSIBM.SYSPRINT table is determined by the BIND PACKAGE statement for the DSNUTILV stored procedure. If the bind option ENCODING(EBCDIC) is specified, the SYSPRINT contents are in EBCDIC. If the bind option ENCODING(UNICODE) is specified, the SYSPRINT contents are in Unicode. The default installation job, DSNTIJRT, contains ENCODING(EBCDIC).

Environment for DSNUTILV

DSNUTILV must run in a WLM environment. The WLM core environment DSNWLM_UTILS. DSNWLM_UTILS is intended for the following Db2 utilities stored procedures only:

- DSNUTILV
- DSNUTILU
- DSNUTILS (deprecated)

If you plan to run other applications in this environment, add the procedure and add the DCB information for SYSIN, as shown in the following example:

```
//SYSIN DD UNIT=SYSDA,SPACE=(4000,(20,20),,,ROUND),
// DCB=(RECFM=V,LRECL=32708)
```

For more information, see [Core WLM environments for Db2-supplied routines \(Db2 Installation and Migration\)](#).

The WLM-established address space for DSNUTILV

The JCL procedure for starting the WLM-established address space in which DSNUTILV runs requires DD statements for DSSPRINT, SYSIN, and SYSPRINT. The SYSIN and SYSPRINT DD statements must allocate workfiles that DSNUTILV can use to temporarily store utility input statements and utility output messages. If you plan to run RUNSTATS and collect distribution statistics, you also need to allocate a DD statement for RNPRIN01.

Db2 provides an address space procedure for DSNWLM_UTILS, which is the core WLM environment for DSNUTILV. That address space procedure is called DSNWLMU. For detailed information about DSNWLMU, see [Core WLM environments for Db2-supplied routines \(Db2 Installation and Migration\)](#).

Authorization required for DSNUTILV

To call the DSNUTILV stored procedure, the owner of the package or plan that contains the CALL statement must have one or more of the following privileges on each package that the stored procedure uses:

- The EXECUTE privilege on the package for DSNUTILV
- Ownership of the package
- PACKADM authority for the package collection
- DATAACCESS authority
- SYSADM authority

Then, to execute the utility, you must use a privilege set that includes the authorization to run the specified utility.

If you use RACF to protect JES resources, you must define a RACF group that is authorized to access those resources and add that RACF group name to the profile of the user ID that calls DSNUTILV.

Utility control statements that are passed to DSNUTILV

Input data sets for the utility control statements can begin with the following Unicode characters:

- A Unicode UTF-8 blank (X'20')
- A Unicode UTF-8 dash (X'2D')
- Uppercase Unicode UTF-8 "A" through "Z" (X'41' through X'5A')

Any utility that requires a sort must include the SORTDEVT keyword in the utility control statement. Use of the SORTNUM keyword is optional.

Also, DSNUTILV does not dynamically allocate data sets. Use the TEMPLATE utility control statement to dynamically allocate data sets.

For more information, see:

[Utility control statements \(Db2 Utilities\)](#)
[DFSORT Application Programming Guide](#)
[Db2 Sort for z/OS](#)

DSNUTILV stored procedure syntax diagram

The following syntax diagram shows the SQL CALL statement for invoking utilities as a stored procedure.

```
►► CALL — DSNUTILV — ( — utility-id, restart, utstmt, retcode — ) ►►
```

DSNUTILV option descriptions

utility-id

Specifies a unique identifier for this utility within Db2.

utility-id is an input parameter of type VARCHAR(16) in Unicode UTF-8, which must be translatable to the following allowable EBCDIC characters:

- A–Z (uppercase and lowercase)
- 0–9
- #, \$, @, €, !, ^, or period (.)

restart

Specifies whether Db2 is to restart a current utility, and, if so, at what point the utility is to be restarted.

restart is an input parameter of type VARCHAR(8) in Unicode UTF-8, which must be translatable to allowable EBCDIC characters. Specify one of the following values for this parameter:

NO or null

Indicates that the utility job is new and is not a restarted job. No other utility with the same utility identifier (UID) can exist.

The default is null.

CURRENT

Restarts the utility at the last commit point.

PHASE

Restarts the utility at the beginning of the currently stopped phase. Use the DISPLAY UTILITY command to determine the currently stopped phase.

PREVIEW

Executes the utility control statements that follow in preview mode.

In preview mode, Db2 parses all utility control statements for syntax errors, but normal utility execution does not occur. If the syntax is valid, Db2 expands all LISTDEF lists and TEMPLATE data set name expressions that are included in SYSIN and prints the results to the SYSPRINT data set. Db2 evaluates and expands all LISTDEF statements into a list of table spaces or index spaces. Db2 also evaluates TEMPLATE data set name expressions into data set names through variable substitution. Db2 also expands lists and data set name expressions from any LISTDEF libraries and TEMPLATE libraries that are referenced by a utility invocation.

If the PREVIEW keyword is omitted, preview processing is turned off with one exception. The absence of this keyword does not override the PREVIEW JCL parameter, which, if specified, remains in effect for the entire job step.

This option is identical to the PREVIEW JCL parameter.

For more information, see:

[Restarting an online utility \(Db2 Utilities\)](#)

[-DISPLAY UTILITY command \(Db2\) \(Db2 Commands\)](#)

[Executing statements in preview mode \(Db2 Utilities\)](#)

utstmt

Specifies the utility control statements.

utstmt is an input parameter of type CLOB(2G) in Unicode UTF-8. If the utility statement is not in Unicode UTF-8, Db2 converts it to UTF-8. Therefore, if you pass a utility control statement in another format, consider the [Possible consequences of character conversion \(Db2 Internationalization Guide\)](#).

You can specify a CLOB file reference variable for this parameter. However, the referenced data set must be in variable record format. For example, suppose that you want DSNUTILV to use LOAD utility statements that were generated by the UNLOAD utility. You can pass these statements to DSNUTILV by using a file reference variable. However, you must first convert the data set that contains these statements to variable record format. (By default, UNLOAD creates these data sets in fixed record format.) Then, make any other necessary changes, such as adding templates for the LOAD data sets.

Restriction: Any keywords, names, or constants in the utility control statement cannot be larger than 32,704 bytes.

Because conversion between UNICODE and EBCDIC is not always exact, some constants (such table names, index names, column names, and constant values) can be incorrectly converted. In such cases, use hexadecimal constants. For example, use X'31' instead of the UNICODE value of character '1'.

For more information, see:

[TEMPLATE \(Db2 Utilities\)](#)

[LOAD statements that are generated by UNLOAD \(Db2 Utilities\)](#)

retcode

Specifies the utility highest return code.

retcode is an output parameter of type INTEGER.

Terminating or restarting a utility with DSNUTILV

If you do not want to restart a utility after a failure, take the following actions:

1. Use the TERM UTIL command to terminate the failing utility.
When you terminate the utility, Db2 deletes the data sets that are needed by the utility.
2. Refresh the WLM environment in one of the following ways:

- Submit the VARY command:

```
VARY WLM,APPLENV=xxx,REFRESH
```

- Call the WLM_REFRESH stored procedure.

If you want to restart a utility after a failure, take the following actions:

1. When you run the utility, use a TEMPLATE utility control statement, and specify DISP (NEW,CATLG,CATLG) in your template for data sets that are needed by the utility.
2. When the utility fails, refresh the WLM environment, but do not terminate the utility.
3. After the utility completes, delete the allocated data sets manually.

For more information, see [“WLM_REFRESH stored procedure” on page 997](#).

Sample program for calling DSNUTILV

The following sample program calls DSNUTILV and is included in SDSNSAMP:

Job DSNTJ6X compiles, link-edits, binds, and runs sample C-language caller program DSN8EDA, which invokes the DSNUTILV stored procedure to execute a utility. DSN8EDA can pass either a utility statement or the name of a data set that contains the utility statement.

For more information, see [Job DSNTJ6R \(Db2 Installation and Migration\)](#).

DSNUTILV output

Db2 creates the result set according to the DECLARE statement shown in [Example of declaring a cursor to select from SYSPRINT](#)

Output from a successful execution of the DSNTJ6R sample job or an equivalent job lists the specified parameters, followed by the messages that are generated by the Db2 DIAGNOSE DISPLAY MEPL utility.

For more information, see [DIAGNOSE \(Db2 Utilities\)](#).

DSN_WLM_APPLENV stored procedure

This procedure provides a convenient way to define, install, and activate a new WLM application environment for Db2. You can also use it to remove WLM application environments.

Environment

DSN_WLM_APPLENV runs in a WLM-established stored procedures address space.

Authorization

To execute the CALL DSN_WLM_APPLENV statement, the owner of the package or plan that contains the CALL statement must have one or more of the following privileges on each package that the stored procedure uses:

- The EXECUTE privilege on the DSN_WLM_APPLENV stored procedure
- Ownership of the stored procedure
- SYSADM authority

If the RACF facility class is active and a profile has been defined for the MVSADMIN.WLM.POLICY facility class, then the caller of the stored procedure needs the following access:

- ACCESS(READ) for action WLMINFO:

```
PERMIT MVSADMIN.WLM.POLICY CLASS(FACILITY) ID(user) ACCESS(READ)
```

- ACCESS(UPDATE) for action ADD, ADD_ACTIVATE, ACTIVATE:

```
PERMIT MVSADMIN.WLM.POLICY CLASS(FACILITY) ID(user) ACCESS(UPDATE)
```

Syntax

```
►► CALL — DSN_WLM_APPLENV — ( — action — , — policyid — , — wlmoptions — , —►  
► — return-code — , — message — ) ►►
```

Procedure parameters

ACTION

An input parameter of type VARCHAR(20) that identifies the type of action to be performed. This is a required parameter and supports the following values:

ACTIVATE

The stored procedure activates a WLM service policy.

ADD

The stored procedure installs a new WLM application environment to an existing WLM service definition without activating a service policy. The new WLM application environment becomes available only on the next activation of a WLM policy.

ADD_ACTIVATE

The stored procedure installs a new WLM application environment to an existing WLM service definition and automatically activates a WLM service policy to enable the new WLM application environment.

REMOVE

The stored procedure installs a WLM application environment from an existing WLM service definition, and installs the modified service definition without activating it.

REMOVE_ACTIVATE

The stored procedure removes a WLM application environment from an existing WLM service definition, installs the modified service definition, and activate it.

REMOVE_IF_EXISTS

The same as REMOVE, except that if the WLM application environment to be removed does not exist, the return code is 4 (warning), instead of 8 (error).

REMIFEXISTS_ACTIVATE

The same as REMOVE_ACTIVATE, except that if the WLM application environment to be removed does not exist, the return code is 4 (warning), instead of 8 (error).

WLMINFO

The stored procedure queries the existing WLM service definition and returns basic information. Examples of the information returned include:

- The service definition name
- The timestamp in the local time the service definition was installed
- The user ID of the service administrator that installed the service definition
- The name of the system on which the service definition was installed from
- The number of application environment currently defined

If the any action other than ACTIVATE or WLMINFO is specified, the WLMOPTIONS input parameter is also required.

POLICYID

An input parameter of type VARCHAR(8) that identifies the WLM service policy to be activated. It can be 1-8 characters long or the word ACTIVE. If the policy specified is ACTIVE, the active service policy is used. This parameter is required if any of the following actions is specified:

- ACTIVATE
- ADD_ACTIVATE
- REMOVE_ACTIVATE
- REMIFEXISTS_ACTIVATE

Otherwise, it is ignored and can be set to NULL or an empty string.

WLMOPTIONS

An input parameter of type VARCHAR(4000).

This parameter with the WLMNAME parameter is required if any of the following actions is specified, and other WLM parameters are not valid:

- ADD
- ADD_ACTIVATE
- REMOVE
- REMOVE_ACTIVATE
- REMOVE_I
- REMIFEXISTS_ACTIVATE

The following WLM options are supported. Separate multiple options by one or more spaces.

WLMNAME(*name*)

WLMNAME is the defined name for an application environment. It can be 1-32 characters long. It cannot begin with the letters SYS. This is a required option.

DESCRIPTION(*description*)

DESCRIPTION is a 32-character area describing the application environment. This option is not required and can be set to an empty value. For example,

```
DESCRIPTION()
```

PROCNAME(*procedure-name*)

PROCNAME defines the JCL procedure that WLM uses to start server address spaces for the application environment. It can be 1-8 characters long. This is a required option.

STARTPARM(*start-up-parameters*)

STARTPARM contains the parameters that WLM uses to start the JCL procedure. The parameters can be up to 115 characters. If the parameters include the subsystem name, the symbol &IWMSSNM can be used to cause WLM to substitute the subsystem name instead of typing the subsystem name directly. This option is useful because multiple instances of the subsystem with different names can use the application environment. For example:

```
STARTPARM(DB2SSN=&IWMSSNM,APPLENV=WLMENV1,NUMTCB=1)
```

This option is not required and can be set to an empty value.

WLMOPT (WLM_MANAGED | SINGLE_SERVER)

WLMOPT tells WLM to limit the number of server address spaces. For example, if a server address space requires exclusive use of a resource, only a single address space can exist. For Db2 routines, you can set a limit of 1 address space per system if required by the routine. Note that if there are multiple Db2 subsystems on a given system, WLM creates 1 server for each Db2 subsystem that calls the routines. A limit of 1 address space per sysplex does not apply to Db2 routines.

This option is not required and can be set to an empty value. The default is WLM_MANAGED.

Examples

Example: Returning the basic information of the WLM service definition

```
CALL SYSPROC.DSN_WLM_APPLENV('WLMINFO', NULL, NULL, '?', ?)
```

Here is an example of the output:

```
RETURN_CODE: 0
MESSAGE: DSNT051I DSNTWLMS ACTIVE WLM SERVICE DEFINITION
          SERVICE DEFINITION NAME      WLSAMPL
          INSTALLED ON                  2010-01-25-07.11.57.764052
          INSTALLED BY                   SYSADM
          INSTALLED FROM                  LABEC130
          NUMBER OF APPL ENVIRONMENT     12
DSNT023I DSNTWLMS DISPLAY WLM INFORMATION SUCCESSFUL
```

Example: Identifying the action and WLM options

```
CALL SYSPROC.DSN_WLM_APPLENV('ADD_ACTIVATE',
                              'ACTIVE',
                              'WLMNAME(DSNWLM_SAMPLE)
                              DESCRIPTION(DB2 SAMPLE WLM ENVIRONMENT)
                              PROCNAME(DSNWLMS)
                              STARTPARM(DB2SSN=&IWMSSNM,APPLENV='DSNWLM_SAMPLE')
                              WLMOPT(WLM_MANAGED)', '?', ?)
```

Here is an example of the output:

```
RETURN_CODE: 0
MESSAGE: DSNT023I DSNTWLMS ADD WLM APPLICATION ENVIRONMENT DSNWLM_SAMPLE SUCCESSFUL

APPLICATION ENVIRONMENT NAME : DSNWLM_SAMPLE
DESCRIPTION                   : DB2 SAMPLE WLM ENVIRONMENT
SUBSYSTEM TYPE                : DB2
PROCEDURE NAME                : DSNWLMS
START PARAMETERS              : DB2SSN=&IWMSSNM,APPLENV='DSNWLM_SAMPLE'

STARTING OF SERVER ADDRESS SPACES FOR A SUBSYSTEM INSTANCE:
(x) MANAGED BY WLM
( ) LIMITED TO A SINGLE ADDRESS SPACE PER SYSTEM
( ) LIMITED TO A SINGLE ADDRESS SPACE PER SYSPLEX

DSNT023I DSNTWLMS ACTIVATE WLM POLICY WLMPLY1 SUCCESSFUL
```

DSN8.CREATE_DGTT stored procedure

The DSN8.CREATE_DGTT sample procedure creates a declared temporary table named SESSION.DBMS_BUFFER.

SESSION.DBMS_BUFFER is used by the sample trace procedures.

Environment

The CREATE_DGTT stored procedure must be called from within a native SQL routine.

Authorization

To execute the CALL statement, the owner of the package or plan that contains the CALL statement must have one or more of the following privileges:

- The EXECUTE privilege on the DSN8.CREATE_DGTT stored procedure
- Ownership of the stored procedure
- SYSADM authority

Syntax

```
▶▶ CALL — DSN8.CREATE_DGTT ▶◀
```

Notes

Creation of this procedure:

Sample job DSNTEJTR creates this procedure.

Examples

Example: Create the SESSION.DBMS_BUFFER declared temporary table.

```
CALL DSN8.CREATE_DGTT;
```

DSN8.DISABLE stored procedure

The DISABLE sample procedure disables the message buffer into which trace messages for native SQL routines are written.

Environment

The DISABLE stored procedure must be called from within a native SQL routine.

Authorization

To execute the CALL statement, the owner of the package or plan that contains the CALL statement must have one or more of the following privileges:

- The EXECUTE privilege on the DSN8.DISABLE stored procedure
- Ownership of the stored procedure
- SYSADM authority

Syntax

```
▶▶ CALL — DSN8.DISABLE ▶◀
```

Notes

Creation of this procedure:

Sample job DSNTEJTR creates this procedure.

Examples

Example: Disable the message buffer for the current debug session.

```
CALL DSN8.DISABLE;
```

DSN8.ENABLE stored procedure

The ENABLE sample procedure enables the message buffer into which trace messages for native SQL routines are written.

Environment

The ENABLE stored procedure must be called from within a native SQL routine.

Authorization

To execute the CALL statement, the owner of the package or plan that contains the CALL statement must have one or more of the following privileges:

- The EXECUTE privilege on the DSN8.ENABLE stored procedure
- Ownership of the stored procedure
- SYSADM authority

Syntax

```
▶▶ CALL — DSN8.ENABLE — ( — buffer-size — ) ▶▶
```

Option descriptions

buffer-size

This value is not used by DSN8.ENABLE.

This is an input argument of type INTEGER.

Notes

Creation of this procedure:

Sample job DSNTJTR creates this procedure.

Examples

Example: Enable the message buffer for the current debug session.

```
CALL DSN8.ENABLE(17000);
```

Example: Enable the message buffer for the current debug session, without specifying the *buffer-size* parameter.

```
CALL DSN8.ENABLE(CAST(NULL AS INTEGER));
```

DSN8.GET_LINE stored procedure

The GET_LINE sample procedure returns a single line from the message buffer, up to, but not including the end-of-line character sequence.

Environment

The GET_LINE stored procedure must be called from within a native SQL routine.

Authorization

To execute the CALL statement, the owner of the package or plan that contains the CALL statement must have one or more of the following privileges:

- The EXECUTE privilege on the DSN8.GET_LINE stored procedure
- Ownership of the stored procedure
- SYSADM authority

Syntax

```
► CALL — DSN8.GET_LINE — ( — line — , — status — ) ◄
```

Option descriptions

line

A line from the message buffer. The CCSID of the result is 1200.

This is an output argument of type VARGRAPHIC(16334).

status

Indicates whether a line was returned from the message buffer. Possible values are:

0

A line was returned.

1

There was no line available to returned.

This is an output argument of type INTEGER.

Notes

Creation of this procedure:

Sample job DSNTJTR creates this procedure.

Putting end-of-line character sequences in the message buffer:

You can put end-of-line character sequences in the message buffer in one of the following ways:

- Use the PUT_LINE procedure to put each line in the message buffer with an end-of-line character sequence.
- After a series of calls to the PUT procedure, call the NEW_LINE procedure.

Examples

Example: Retrieve a line from the message buffer into SQL variable LINE. Retrieve the status of the request into SQL variable STATUS.

```
CALL DSN8.GET_LINE(LINE,STATUS);
```

DSN8.GET_LINES stored procedure

The GET_LINES sample procedure returns one or more lines from the message buffer, and stores the text in an array.

Each line of text in the message buffer, up to, but not including the end-of-line character, is stored in an element of the target array.

Environment

The GET_LINES stored procedure must be called from within a native SQL routine.

Authorization

To execute the CALL statement, the owner of the package or plan that contains the CALL statement must have one or more of the following privileges:

- The EXECUTE privilege on the DSN8.GET_LINES stored procedure
- Ownership of the stored procedure
- SYSADM authority

Syntax

```
► CALL — DSN8.GET_LINES — ( — lines — , — numlines — ) ◄
```

Option descriptions

lines

Lines of text from the message buffer. The CCSID of the result is 1200.

This is an output argument of user-defined type DSN8.GRPHICARR. DSN8.GRPHICARR is defined as:

```
VARGRAPHIC(16334) ARRAY[2147483647]
```

numlines

When *numlines* is used as an input argument, it specifies the number of lines to retrieve from the message buffer.

When *numlines* is used as an output argument, it specifies the number of lines that were retrieved from the message buffer. When the output value of *numlines* is less than the input value of *numlines*, the number of lines remaining in the message buffer is less than the requested number of lines.

If the input value of *numlines* is 0 or NULL, NULL is returned for *lines*, and 0 is returned for *numlines*.

This is an input and output argument of type INTEGER.

Notes

Creation of this procedure:

Sample job DSNTJTR creates this procedure.

Examples

Example: Retrieve five lines from the message buffer into SQL variable LINES. Use SQL variable NUMLINES to specify that you want five lines, and to determine the number of lines that you receive.

```
CALL DSN8.GET_LINES(LINES,NUMLINES);
```

DSN8.NEW_LINE stored procedure

The NEW_LINE sample procedure writes an end-of-line character sequence to the message buffer.

Each line of text in the message buffer, up to, but not including the end-of-line character, is stored in an element of the target array.

Environment

The NEW_LINE stored procedure must be called from within a native SQL routine.

Authorization

To execute the CALL statement, the owner of the package or plan that contains the CALL statement must have one or more of the following privileges:

- The EXECUTE privilege on the DSN8.NEW_LINE stored procedure
- Ownership of the stored procedure
- SYSADM authority

Syntax

```
▶▶ CALL — DSN8.NEW_LINE ▶◀
```

Notes

Creation of this procedure:

Sample job DSNTJTR creates this procedure.

Examples

Example: Write an end-of-line character sequence to the message buffer.

```
CALL DSN8.NEW_LINE;
```

DSN8.PUT stored procedure

The PUT sample procedure writes a line to the message buffer, without an end-of-line character sequence at the end.

Environment

The PUT stored procedure must be called from within a native SQL routine.

Authorization

To execute the CALL statement, the owner of the package or plan that contains the CALL statement must have one or more of the following privileges:

- The EXECUTE privilege on the DSN8.PUT stored procedure
- Ownership of the stored procedure
- SYSADM authority

Syntax

```
► CALL — DSN8.PUT — ( — item — ) ►
```

Option descriptions

item

Specifies the line to write to the message buffer. If *item* is an empty string or NULL, the message buffer is unmodified.

This is an output argument of type VARGRAPHIC(16334).

Notes

Creation of this procedure:

Sample job DSNTJTR creates this procedure.

Adding an end-of-line character sequence to the end of the message buffer:

When you use the DSN8.PUT procedure to write a string to the message buffer, you can use the NEW_LINE procedure to add the end-of-line character sequence to the end of the message buffer.

Examples

Example: Write the string 'Hello' to the message buffer, without an end-of-line character sequence at the end.

```
CALL DSN8.PUT('Hello');
```

Related reference

[DSN8.NEW_LINE stored procedure](#)

The NEW_LINE sample procedure writes an end-of-line character sequence to the message buffer.

DSN8.PUT_LINE stored procedure

The PUT_LINE sample procedure writes a line, including the end-of-line character sequence, to the message buffer.

Environment

The PUT_LINE stored procedure must be called from within a native SQL routine.

Authorization

To execute the CALL statement, the owner of the package or plan that contains the CALL statement must have one or more of the following privileges:

- The EXECUTE privilege on the DSN8.PUT_LINE stored procedure
- Ownership of the stored procedure
- SYSADM authority

Syntax

```
► CALL — DSN8.PUT_LINE — ( — item — ) ►
```

Option descriptions

item

Specifies the line to write to the message buffer. If *item* is an empty string or NULL, a null character is put in the message buffer.

This is an output argument of type VARGRAPHIC(16334).

Notes

Creation of this procedure:

Sample job DSNTEJTR creates this procedure.

Examples

Example: Write the string 'Hello' to the message buffer, with an end-of-line sequence at the end.

```
CALL DSN8.PUT_LINE('Hello');
```

Objects that are used by the sample trace stored procedures

The sample trace stored procedures use a global variable, an user-defined array type, and a declared temporary table.

Sample job DSNTEJTR creates those objects.

Global variable DSN8.DBMS_ENABLE

The DSN8.DBMS_ENABLE global variable is used to test if the trace is enabled.

Example: Test whether the trace is enabled before attempting to write to the trace buffer.

```
IF DSN8.DBMS_ENABLE = 'Y' THEN CALL DSN8.PUT_LINE (LINE);  
END IF;
```

Array type DSN8.GRPHICARR

The user-defined array type DSN8.GRPHICARR is used for the first parameter to the DSN8.GET_LINES procedure. An array variable that is declared with the DSN8.GRPHICARR type is used to hold lines that are retrieved from the message buffer.

DSN8.GRPHICARR is defined as:

```
VARGRAPHIC(16334) ARRAY[2147483647]
```

Example: Declare SQL variable LINES to hold lines that are retrieved from the message buffer.

```
DECLARE LINES DSN8.GRPHICARR;
```

Declared temporary table SESSION.DBMS_BUFFER

The SESSION.DBMS_BUFFER declared temporary table contains the message buffer.

GET_CONFIG stored procedure

The GET_CONFIG stored procedure retrieves data server configuration information.

GUI

This data server configuration information includes:

- Data sharing group information
- Db2 subsystem status information
- Db2 subsystem parameters, DSNHDECP or a user-specified application defaults module, and the IRLM parameters that are found in IFCID 106 section 5
- Db2 distributed access information
- Active log data set information
- The time of the last restart of Db2
- Resource limit facility information
- Connected Db2 subsystems information

The GET_CONFIG stored procedure supports SBCS CCSID only. That is, all data (input and output) must exist in Unicode CCSID 367.

Support for Katakana CCSID 290 is limited. Any user-specific information specified in the `xml_input` document (such as the string input for DB2 Data Sharing Group Members) must contain only valid EBCDIC CCSID 37 characters, and these EBCDIC characters must exist in Unicode CCSID 367. Likewise, any requested information that is converted to Unicode CCSID 367 and written to the `xml_output` document, must also contain only valid EBCDIC CCSID 37 characters, and these EBCDIC characters must exist in Unicode CCSID 367.

Environment

The GET_CONFIG stored procedure runs in a WLM-established stored procedures address space.

Authorization

To execute the CALL statement, the owner of the package or plan that contains the CALL statement must have one or more of the following privileges or authorities:

- The EXECUTE privilege on the GET_CONFIG stored procedure
- Ownership of the stored procedure
- One of the following authorities:
 - SYSTEM DBADM
 - SYSOPR
 - SYSCTRL
 - SYSADM

Syntax

```

CALL GET_CONFIG ( major_version , minor_version ,
                  NULL          NULL
                , requested_locale , xml_input , xml_filter ,
                  NULL          NULL          NULL
                , xml_output , xml_message )

```

The schema is SYSPROC.

Option descriptions

major_version

An input and output parameter of type INTEGER that indicates the major document version. On input, this parameter indicates the major document version that you support for the XML documents that are passed as parameters in the stored procedure (*xml_input*, *xml_output*, and *xml_message*). The stored procedure processes all XML documents in the specified version, or returns an error (-20457) if the version is invalid.

On output, this parameter specifies the highest major document version that is supported by the procedure. To determine the highest supported document version, specify NULL for this input parameter and all other required parameters. Currently, the highest major document version that is supported is 2. Major document version 1 is also supported.

If the XML document in the *xml_input* parameter specifies the **Document Type Major Version** key, the value for that key must be equal to the value provided in the *major_version* parameter, or an error (+20458) is raised.

This parameter is used in conjunction with the *minor_version* parameter. Therefore, you must specify both parameters together. For example, you must specify both as either NULL, or non-NULL.

minor_version

An input and output parameter of type INTEGER that indicates the minor document version. On input, this parameter specifies the minor document version that you support for the XML documents that are passed as parameters for this stored procedure (*xml_input*, *xml_output*, and *xml_message*). The stored procedure processes all XML documents in the specified version, or returns an error (-20457) if the version is invalid.

On output, this parameter indicates the highest minor document version that is supported for the highest supported major version. To determine the highest supported document version, specify NULL for this input parameter and all other required parameters. Currently, the highest and only minor document version that is supported is 0 (zero).

If the XML document in the *xml_input* parameter specifies the **Document Type Minor Version** key, the value for that key must be equal to the value provided in the *minor_version* parameter, or an error (+20458) is raised.

This parameter is used in conjunction with the *major_version* parameter. Therefore, you must specify both parameters together. For example, you must specify both as either NULL, or non-NULL.

requested_locale

An input parameter of type VARCHAR(33) that specifies a locale. If the specified language is supported on the server, translated content is returned in the *xml_output* and *xml_message* parameters. Otherwise, content is returned in the default language. Only the language and possibly the territory information is used from the locale. The locale is not used to format numbers or influence the document encoding. For example, key names are not translated. The only translated portion of XML output and XML message documents are **Display Name**, **Display Unit**, and **Hint**. The value might be globalized where applicable. You should always compare the requested language to the language that is used in the XML output document (see the **Document Locale** entry in the XML output document).

Currently, the supported values for *requested_locale* are en_US and NULL. If you specify a null value, the result is the same as specifying en_US.

xml_input

An input parameter of type BLOB(2G) that specifies an XML input document of type Data Server Configuration Input in UTF-8 that contains input values for the stored procedure.

To pass an XML input document to the stored procedure, you must specify the *major_version* parameter as 2 and the *minor_version* parameter as 0 (zero).

For a non-data sharing system, a sample of a Version 2.0 XML input document is as follows:

```
<plist version="1.0">
<?xml version="1.0" encoding="UTF-8" ?>
```

```

<dict>
  <key>Document Type Name</key>
  <string>Data Server Configuration Input</string>
  <key>Document Type Major Version</key>
  <integer>2</integer>
  <key>Document Type Minor Version</key>
  <integer>0</integer>
  <key>Document Locale</key>
  <string>en_US</string>
  <key>Complete</key><false/>
  <key>Optional Parameters</key>
  <dict>
    <key>Include</key>
    <dict>
      <key>Value</key>
      <array>
        <string>DB2 Subsystem Status Information</string>
        <string>DB2 Subsystem Parameters</string>
        <string>DB2 Distributed Access Information</string>
        <string>Active Log Data Set Information</string>
        <string>Time of Last DB2 Restart</string>
        <string>Resource Limit Facility Information</string>
        <string>Connected DB2 Subsystem</string>
      </array>
    </dict>
  </dict>
</dict>
</plist>

```

For a data sharing system, a sample of a Version 2.0 XML input document is as follows:

```

<plist version="1.0">
  <?xml version="1.0" encoding="UTF-8" ?>
  <dict>
    <key>Document Type Name</key>
    <string>Data Server Configuration Input</string>
    <key>Document Type Major Version</key>
    <integer>2</integer>
    <key>Document Type Minor Version</key>
    <integer>0</integer>
    <key>Document Locale</key>
    <string>en_US</string>
    <key>Complete</key><false/>
    <key>Optional Parameters</key>
    <dict>
      <key>Include</key>
      <dict>
        <key>Value</key>
        <array>
          <string>Common Data Sharing Group Information</string>
          <string>DB2 Subsystem Status Information</string>
          <string>DB2 Subsystem Parameters</string>
          <string>DB2 Distributed Access Information</string>
          <string>Active Log Data Set Information</string>
          <string>Time of Last DB2 Restart</string>
          <string>Resource Limit Facility Information</string>
          <string>Connected DB2 Subsystem</string>
        </array>
      </dict>
      <key>DB2 Data Sharing Group Members</key>
      <dict>
        <key>Value</key>
        <array>
          <string>DB2A</string>
          <string>DB2B</string>
        </array>
      </dict>
    </dict>
  </dict>
</plist>

```

When passing an XML input document to the stored procedure, you must specify the **Document Type Name** key. In a non-data sharing system, you must specify the **Include** parameter. In a data sharing system, you must specify at least one of the following parameters:

- **Include**
- **DB2 Data Sharing Group Members**

If no XML input document is passed to the stored procedure, and you specified the *major_version* parameter as 2 and the *minor_version* parameter as 0 (zero), the stored procedure returns the following parameters for a non-data sharing system in a Version 2.0 XML output document by default:

- **DB2 Subsystem Status Information**
- **DB2 Subsystem Parameters**
- **DB2 Distributed Access Information**
- **Active Log Data Set Information**
- **Time of Last DB2 Restart**
- **Resource Limit Facility Information**
- **Connected DB2 Subsystem**

For a data sharing system, the same information is returned for each member of a data sharing group, plus the **Common Data Sharing Group Information** parameter.

If you passed a Version 2.0 XML input document to the stored procedure, the stored procedure returns the information in a Version 2.0 XML output document. The information returned is dependent on what you specified in the **Include** array and in the **DB2 Data Sharing Group Members** array (if applicable). For a non-data sharing system, the items that are specified in the **Include** array are returned. For a data sharing system, the following information is returned:

- The items that are specified in the **Include** array for each Db2 member that is specified in the **DB2 Data Sharing Group Members** array, if both the **Include** parameter and the **DB2 Data Sharing Group Members** parameter are specified.
- The items that are specified in the **Include** array for every Db2 member in the data sharing group, if only the **Include** parameter is specified.
- The **Common Data Sharing Group Information** and the following items for each member that is specified in the **DB2 Data Sharing Group Members** array, if only the **DB2 Data Sharing Group Members** parameter is specified:
 - **DB2 Subsystem Status Information**
 - **DB2 Subsystem Parameters**
 - **DB2 Distributed Access Information**
 - **Active Log Data Set Information**
 - **Time of Last DB2 Restart**
 - **Resource Limit Facility Information**
 - **Connected DB2 Subsystem**

Note: If the **Common Data Sharing Group Information** item is specified in the **Include** array, this information is returned only once for the data sharing group. This information is not returned repeatedly for every Db2 member that is processed.

Complete mode: For an example of a Version 2.0 XML input document that is returned by the *xml_output* parameter when the stored procedure is running in Complete mode in a non-data sharing system, see [“Example 4” on page 935](#) in the Examples section. For an example of a Version 2.0 XML input document that is returned by the *xml_output* parameter when the stored procedure is running in Complete mode in a data sharing system with two Db2 members, DB2A and DB2B, see [“Example 5” on page 936](#).

xml_filter

An input parameter of type BLOB(4K) in UTF-8 that specifies a valid XPath query string. Use a filter when you want to retrieve a single value from an XML output document. For more information, see [XPath expressions for filtering output \(Db2 Administration Guide\)](#).

The following example selects the value for the Data Server Product Version from the XML output document:

```
/plist/dict/key[.='Data Server Product Version']/following-sibling::string[1]
```

If the key is not followed by the specified sibling, an error is returned.

xml_output

An output parameter of type BLOB(2G) that returns a complete XML output document of type Data Server Configuration Output in UTF-8. If a filter is specified, this parameter returns a string value. If the stored procedure is unable to return a complete output document (for example, if a processing error occurs that results in an SQL warning or error), this parameter is set to NULL.

The *xml_output* parameter can return either a Version 1.0 or Version 2.0 XML output document depending on the *major_version* and *minor_version* parameters that you specify. For information about the content of a Version 2.0 XML output document, see the option description for the *xml_input* parameter.

For a sample Version 1.0 XML output document, see [“Example 1” on page 928](#) in the Examples section.

For a sample Version 2.0 XML output document in a non-data sharing system, see [“Example 6” on page 936](#).

For a sample Version 2.0 XML output document in a data sharing system, see [“Example 7” on page 938](#).

xml_message

An output parameter of type BLOB(64K) that returns a complete XML output document of type Data Server Message in UTF-8 that provides detailed information about an SQL warning condition. This document is returned when a call to the stored procedure results in an SQL warning, and the warning message indicates that additional information is returned in the XML message output document. If the warning message does not indicate that additional information is returned, then this parameter is set to NULL.

The *xml_message* parameter can return either a Version 1.0 or Version 2.0 XML message document depending on the *major_version* and *minor_version* parameters that you specify.

For an example of an XML message document, see [“Example 2” on page 933](#).

If the GET_CONFIG stored procedure is processing more than one Db2 member in a data sharing system and an error is encountered when processing one of the Db2 members, the stored procedure specifies the name of the Db2 member that is causing the error as the value of the **DB2 Object** key in the XML message document. The value of the **Short Message Text** key applies to the Db2 member that is specified.

The following example shows a fragment of a Version 2.0 XML message document with the **DB2 Object** key specified:

```
<key>Short Message Text</key>
  <dict>
    <key>Display Name</key>
    <string>Short Message Text</string>
    <key>Value</key>
    <string>DSNA6xxI DSNADMGC .....</string>
    <key>DB2 Object</key>
    <string>DB2B</string>
    <key>Hint</key>
    <string />
  </dict>
```

Examples

Example 1

The following example shows a fragment of a Version 1.0 XML output document for the GET_CONFIG stored procedure for a data sharing member. For a non-data sharing member, the following entries in the **DB2 Distributed Access Information** item are not included: **Resynchronization Domain**, **Alias List**, **Member IPv4 Address**, **Member IPv6 Address**, and **Location Server List**.

The two major sections that the XML output document always contains are **Common Data Sharing Group Information** and **DB2 Subsystem Specific Information**. In this example, the ellipsis (. . .) represent a dictionary entry that is comprised of **Display Name**, **Value**, and **Hint**, such as:

```
<dict>
  <key>Display Name</key>
  <string>DDF Status</string>
  <key>Value</key>
  <string>STARTD</string>
  <key>Hint</key>
  <string />
</dict>
```

```
<?xml version="1.0" encoding="UTF-8"?>
<plist version="1.0">
<dict>
  <key>Document Type Name</key>
  <string>Data Server Configuration Output</string>
  <key>Document Type Major Version</key>
  <integer>1</integer>
  <key>Document Type Minor Version</key>
  <integer>0</integer>
  <key>Data Server Product Name</key>
  <string>DSN</string>
  <key>Data Server Product Version</key>
  <string>12.1.5</string>
  <key>Data Server Major Version</key>
  <integer>12</integer>
  <key>Data Server Minor Version</key>
  <integer>1</integer>
  <key>Data Server Platform</key>
  <string>z/OS</string>
  <key>Document Locale</key>
  <string>en_US</string>

  <key>Common Data Sharing Group Information</key>
  <dict>
    <key>Display Name</key>
    <string>Common Data Sharing Group Information</string>
    <key>Data Sharing Group Name</key>
    . . .
    <key>Data Sharing Group Catalog Level</key>
    . . .
    <key>Data Sharing Group Current Function Level</key>
    . . .
    <key>Data Sharing Group Highest Activated Function Level</key>
    . . .
    <key>Data Sharing Group Highest Possible Function Level</key>
    . . .
    <key>Data Sharing Group Protocol Level</key>
    . . .
    <key>Data Sharing Group Attach Name</key>
    . . .
    <key>Data Sharing Group Encryption Key Label</key>
    . . .
    <key>Migration Readiness Status</key>
    . . .
    <key>Migration Readiness Reason</key>
    . . .
    <key>SCA Structure Size</key>
    . . .
    <key>SCA Status</key>
    . . .
    <key>SCA in Use</key>
    . . .
    <key>LOCK1 Structure Size</key>
    . . .
    <key>Number of Lock Entries</key>
    . . .
    <key>Number of List Entries</key>
    . . .
    <key>List Entries in Use</key>
    . . .
    <key>Hint</key><string></string>
  </dict>

  <key>DB2 Subsystem Specific Information</key>
  <dict>
    <key>Display Name</key>
```

```

<string>DB2 Subsystem Specific Information</string>
<key>V91A</key>
<dict>
  <key>Display Name</key>
  <string>V91A</string>
  <key>DB2 Subsystem Status Information</key>
  <dict>
    <key>Display Name</key>
    <string>DB2 Subsystem Status Information</string>
    <key>DB2 Member Identifier</key>
    ...
    <key>DB2 Member Name</key>
    ...
    <key>DB2 Command Prefix</key>
    ...
    <key>DB2 Status</key>
    ...
    <key>DB2 System Level</key>
    ...
    <key>System Name</key>
    ...
    <key>IRLM Subsystem Name</key>
    ...
    <key>IRLM Procedure Name</key>
    ...
    <key>Code Level</key>
    ...
    <key>SPE Apar</key>
    ...
    <key>Migration Eligible</key>
    ...
    <key>Hint</key>
  </dict>
  <key>DB2 Subsystem Parameters</key>
  <dict>
    <key>Display Name</key>
    <string>DB2 Subsystem Parameters</string>
    <key>DSNHDECP</key>
    <dict>
      <key>Display Name</key>
      <string>DSNHDECP</string>
      <key>AGCCSID</key>
      <dict>
        <key>Display Name</key>
        <string>AGCCSID</string>
        <key>Installation Panel Name</key>
        ...
        <key>Installation Panel Field Name</key>
        ...
        <key>Location on Installation Panel</key>
        ...
        <key>Subsystem Parameter Value</key>
        ...
        <key>Online Update</key>
        ...
        <key>Hint</key><string></string>
      </dict>
      --- This is only a fragment of the
          DSNHDECP parameters that are returned
          by the GET_CONFIG stored procedure. ---
      <key>Hint</key><string></string>
    </dict>
    --- This is only a fragment of the
        DB2 subsystem parameters that are returned
        by the GET_CONFIG stored procedure. ---
    <key>Hint</key><string></string>
  </dict>
  <key>DB2 Distributed Access Information</key>
  <dict>
    <key>Display Name</key>
    <string>DB2 Distributed Access Information</string>
    <key>DDF Status</key>
    ...
    <key>Location Name</key>
    ...
    <key>LU Name</key>
  </dict>

```

```

...
<key>Generic LU Name</key>
...
<key>TCP/IP Port</key>
...
<key>Secure Port</key>
...
<key>Resynchronization Port</key>
...
<key>IP Name</key>
...
<key>IPv4 Address</key>
...
<key>IPv6 Address</key>
...
<key>SQL Domain</key>
...
<key>Resynchronization Domain</key>
...
<key>Alias List</key>
<dict>
  <key>Display Name</key>
  <string>Alias List</string>
  <key>1</key>
  <dict>
    <key>Display Name</key>
    <string>1</string>
    <key>Name</key>
    ...
    <key>Port</key>
    ...
    <key>Secure Port</key>
    ...
    <key>Hint</key><string />
  </dict>
  <key>2</key>
  <dict>
    <key>Display Name</key>
    <string>2</string>
    <key>Name</key>
    ...
    <key>Port</key>
    ...
    <key>Secure Port</key>
    ...
    <key>Hint</key><string />
  </dict>
  <key>Hint</key><string />
</dict>
<key>Member IPv4 Address</key>
...
<key>Member IPv6 Address</key>
...
<key>DT - DDF Thread Value</key>
...
<key>CONDBAT - Maximum Inbound Connections</key>
...
<key>MDBAT - Maximum Concurrent Active DBATs</key>
...
<key>ADBAT - Active DBATs</key>
...
<key>QUEDBAT - Times that ADBAT Reached MDBAT Limit</key>
...
<key>INADBAT - Inactive DBATs (Type 1)</key>
...
<key>CONQUED - Queued Connections</key>
...
<key>DSCDBAT - Pooled DBATs</key>
...
<key>INACONN - Inactive Connections (Type 2)</key>
...
<key>Location Server List</key>
<dict>
  <key>Display Name</key>
  <string>Location Server List</string>
  <key>1</key>
  <dict>
    <key>Display Name</key>
    <string>1</string>
    <key>Weight</key>
    ...
    <key>IPv4 Address</key>

```

```

        ...
        <key>IPv6 Address</key>
        ...
        <key>Hint</key><string />
    </dict>
    <key>2</key>
    <dict>
        <key>Display Name</key>
        <string>2</string>
        <key>Weight</key>
        ...
        <key>IPv4 Address</key>
        ...
        <key>IPv6 Address</key>
        ...
        <key>Hint</key><string />
    </dict>
    <key>Hint</key><string></string>
</dict>
<key>Active Log Data Set Information</key>
<dict>
    <key>Display Name</key>
    <string>Active Log Data Set Information</string>
    <key>Active Log Copy 01</key>
    <dict>
        <key>Display Name</key>
        <string>Active Log Copy 01</string>
        <key>Data Set Name</key>
        ...
        <key>Data Set Volumes</key>
        <dict>
            <key>Display Name</key>
            <string>Data Set Volumes</string>
            <key>Value</key>
            <array>
                <string>CATLGJ</string>
            </array>
            <key>Hint</key><string></string>
        </dict>
        <key>Key Label</key>
        ...
        <key>Hint</key><string></string>
    </dict>
    <key>Active Log Copy 02</key>
    <dict>
        --- The format of this dictionary entry is
        the same as that of Active Log Copy 01. ---
    </dict>
    <key>Hint</key><string></string>
</dict>

<key>Time of Last DB2 Restart</key>
...

<key>Resource Limit Facility Information</key>
<dict>
    <key>Display Name</key>
    <string>Resource Limit Facility Information</string>
    <key>RLF Table Names</key>
    <dict>
        <key>Display Name</key>
        <string>RLF Table Names</string>
        <key>Value</key>
        <array>
            <string>SYSADM.DSNRLST01</string>
        </array>
        <key>Hint</key><string></string>
    </dict>
    <key>Hint</key><string></string>
</dict>

<key>Connected DB2 Subsystem</key>
...
<key>Hint</key><string></string>
</dict>
<key>Hint</key><string></string>
</dict>
<key>Hint</key><string></string>

```



```
</dict>
</plist>
```

Example 2

The following example shows a sample XML message document for the GET_CONFIG stored procedure. Similar to an XML output document, the details about an SQL warning condition are encapsulated in a dictionary entry, which is comprised of **Display Name**, **Value**, and **Hint**.

```
<?xml version="1.0" encoding="UTF-8" ?>
<plist version="1.0">
<dict>
  <key>Document Type Name</key><string>Data Server Message</string>
  <key>Document Type Major Version</key><integer>1</integer>
  <key>Document Type Minor Version</key><integer>0</integer>
  <key>Data Server Product Name</key><string>DSN</string>
  <key>Data Server Product Version</key><string>12.1.5</string>
  <key>Data Server Major Version</key><integer>12</integer>
  <key>Data Server Minor Version</key><integer>1</integer>
  <key>Data Server Platform</key><string>z/OS</string>
  <key>Document Locale</key><string>en_US</string>
  <key>Short Message Text</key>
  <dict>
    <key>Display Name</key><string>Short Message Text</string>
    <key>Value</key>
    <string>DSNA630I DSNADMGC A PARAMETER FORMAT OR CONTENT ERROR WAS FOUND.
      The XML input document must be empty or NULL.</string>
    <key>Hint</key><string />
  </dict>
</dict>
</plist>
```

Example 3

This example shows a simple and static Java program that calls the GET_CONFIG stored procedure with an XPath that queries the value of the data server's IP address. The XPath is statically created as a string object by the program, and then converted to a BLOB to serve as input for the *xml_filter* parameter. After the stored procedure is called, the *xml_output* parameter contains only a single string and no XML document. This output is materialized as a file called *xml_output.xml* that is in the same directory where the GetConfDriver class resides.

```

//*****
// Licensed Materials - Property of IBM
// 5635-DB2
// (C) COPYRIGHT 1982, 2006 IBM Corp. All Rights Reserved.
//
// STATUS = Version 9
//*****
// Source file name: GetConfDriver.java
//
// Sample: How to call SYSPROC.GET_CONFIG with a valid XPath to extract the
// IP Address.
//
//The user runs the program by issuing:
//java GetConfDriver <alias or //server/database> <userid> <password>
//
//The arguments are:
//<alias> - DB2 subsystem alias for type 2 or //server/database for type 4
// connectivity
//<userid> - user ID to connect as
//<password> - password to connect with
//*****
import java.io.*;
import java.sql.*;
public class GetConfDriver
{
    public static void main (String[] args)
    {
        Connection con = null;
        CallableStatement cstmt = null;
        String driver = "com.ibm.db2.jcc.DB2Driver";
        String url = "jdbc:db2:";
        String userid = null;
        String password = null;

        // Parse arguments
        if (args.length != 3)
```

```

    {
        System.err.println("Usage: GetConfDriver <alias or //server/database>
<userid> <password>");
        System.err.println("where <alias or //server/database> is DB2
subsystem alias or //server/database for type 4 connectivity");
        System.err.println(" <userid> is user ID to connect as");
        System.err.println(" <password> is password to connect with");
        return;
    }
    url += args[0];
    userid = args[1];
    password = args[2];

    try {

        byte[] xml_input;
        String str_xmlfilter = new String(
            "/plist/dict/key[.='DB2 Subsystem Specific Information']/following-
sibling::dict[1]" +
            "/key[.='V91A']/following-sibling::dict[1]" +
            "/key[.='DB2 Distributed Access Information']/following-sibling::dict[1]" +
            "/key[.='IP Address']/following-sibling::dict[1]" +
            "/key[.='Value']/following-sibling::string[1]");

        /* Convert XML_FILTER to byte array to pass as BLOB */
        byte[] xml_filter = str_xmlfilter.getBytes("UTF-8");

        // Load the DB2 Universal JDBC Driver
        Class.forName(driver);

        // Connect to database
        con = DriverManager.getConnection(url, userid, password);
        con.setAutoCommit(false);

        cstmt = con.prepareStatement("CALL SYSPROC.GET_CONFIG(?,?,?,?,?,?)");

        // Major / Minor Version / Requested Locale
        cstmt.setInt(1, 1);
        cstmt.setInt(2, 0);
        cstmt.setString(3, "en_US");
        // No Input document
        cstmt.setObject(4, null, Types.BLOB);
        cstmt.setObject(5, xml_filter, Types.BLOB);

        // Output Params
        cstmt.registerOutParameter(1, Types.INTEGER);
        cstmt.registerOutParameter(2, Types.INTEGER);
        cstmt.registerOutParameter(6, Types.BLOB);
        cstmt.registerOutParameter(7, Types.BLOB);

        cstmt.execute();
        con.commit();

        SQLWarning ctstmt_warning = cstmt.getWarnings();
        if (ctstmt_warning != null) {
            System.out.println("SQL Warning: " + ctstmt_warning.getMessage());
        }
        else {
            System.out.println("SQL Warning: None\r\n");
        }

        System.out.println("Major Version returned " + cstmt.getInt(1) );
        System.out.println("Minor Version returned " + cstmt.getInt(2) );

        /* get output BLOBs */
        Blob b_out = cstmt.getBlob(6);

        if(b_out != null)
        {
            int out_length = (int)b_out.length();
            byte[] bxml_output = new byte[out_length];

            /* open an inputstream on BLOB data */
            InputStream instr_out = b_out.getBinaryStream();

            /* copy from inputstream into byte array */
            int out_len = instr_out.read(bxml_output, 0, out_length);

            /* write byte array into FileOutputStream */
            FileOutputStream fxml_out = new FileOutputStream("xml_output.xml");

```

```

        /* write byte array content into FileOutputStream */
        fxml_out.write(bxml_output, 0, out_length );

        //Close streams
        instr_out.close();
        fxml_out.close();
    }

    Blob b_msg = cstmt.getBlob(7);
    if(b_msg != null)
    {
        int msg_length = (int)b_msg.length();
        byte[] bxml_message = new byte[msg_length];

        /* open an inputstream on BLOB data */
        InputStream instr_msg = b_msg.getBinaryStream();

        /* copy from inputstream into byte array */
        int msg_len = instr_msg.read(bxml_message, 0, msg_length);

        /* write byte array content into FileOutputStream */
        FileOutputStream fxml_msg = new FileOutputStream(new File
("xml_message.xml"));
        fxml_msg.write(bxml_message, 0, msg_length);

        //Close streams
        instr_msg.close();
        fxml_msg.close();
    }
}
catch (SQLException sqle) {
    System.out.println("Error during CALL "
        + " SQLSTATE = " + sqle.getSQLState()
        + " SQLCODE = " + sqle.getErrorCode()
        + " : " + sqle.getMessage());
}
catch (Exception e) {
    System.out.println("Internal Error " + e.toString());
}
finally
{
    if(cstmt != null)
        try { cstmt.close(); } catch ( SQLException sqle)
{ sqle.printStackTrace(); }
    if(con != null)
        try { con.close(); } catch ( SQLException sqle)
{ sqle.printStackTrace(); }
}
}
}

```

Example 4

The following example shows a Version 2.0 XML input document that is returned by the *xml_output* parameter when the stored procedure is running in Complete mode in a non-data sharing system:

```

<plist version="1.0">
<?xml version="1.0" encoding="UTF-8" ?>
<dict>
  <key>Document Type Name</key>
  <string>Data Server Configuration Input</string>
  <key>Document Type Major Version</key>
  <integer>2</integer>
  <key>Document Type Minor Version</key>
  <integer>0</integer>
  <key>Document Locale</key>
  <string>en_US</string>
  <key>Optional Parameters</key>
  <dict>
    <key>Display Name</key>
    <string>Optional Parameters</string>
    <key>Include</key>
    <dict>
      <key>Display Name</key>
      <string>Include</string>
      <key>Value</key>
      <array>
        <string>DB2 Subsystem Status Information</string>
        <string>DB2 Subsystem Parameters</string>
        <string>DB2 Distributed Access Information</string>
        <string>Active Log Data Set Information</string>

```

```

    <string>Time of Last DB2 Restart</string>
    <string>Resource Limit Facility Information</string>
    <string>Connected DB2 Subsystem</string>
  </array>
  <key>Hint</key><string />
</dict>
<key>Hint</key><string />
</dict>
</dict>
</plist>

```

Example 5

The following example shows a Version 2.0 XML input document that is returned by the *xml_output* parameter when the stored procedure is running in Complete mode in a data sharing system with two Db2 members, DB2A and DB2B:

```

<plist version="1.0">
  <?xml version="1.0" encoding="UTF-8" ?>
  <dict>
    <key>Document Type Name</key>
    <string>Data Server Configuration Input</string>
    <key>Document Type Major Version</key>
    <integer>2</integer>
    <key>Document Type Minor Version</key>
    <integer>0</integer>
    <key>Document Locale</key>
    <string>en_US</string>
    <key>Optional Parameters</key>
    <dict>
      <key>Display Name</key>
      <string>Optional Parameters</string>
      <key>Include</key>
      <dict>
        <key>Display Name</key>
        <string>Include</string>
        <key>Value</key>
        <array>
          <string>Common Data Sharing Group Information</string>
          <string>DB2 Subsystem Status Information</string>
          <string>DB2 Subsystem Parameters</string>
          <string>DB2 Distributed Access Information</string>
          <string>Active Log Data Set Information</string>
          <string>Time of Last DB2 Restart</string>
          <string>Resource Limit Facility Information</string>
          <string>Connected DB2 Subsystem</string>
        </array>
        <key>Hint</key><string />
      </dict>
    <key>DB2 Data Sharing Group Members</key>
    <dict>
      <key>Display Name</key>
      <string>DB2 Data Sharing Group Members</string>
      <key>Value</key>
      <array>
        <string>DB2A</string>
        <string>DB2B</string>
      </array>
      <key>Hint</key><string />
    </dict>
    <key>Hint</key><string />
  </dict>
</dict>
</plist>

```

Example 6

This example shows a fragment of a Version 2.0 XML output document for the GET_CONFIG stored procedure in a non-data sharing system. An XML input document is not passed to the stored procedure. The ellipsis (..) represent a dictionary entry that is comprised of **Display Name**, **Value**, and **Hint**, as in the following example, or an entry that is the same as the corresponding entry in a Version 1.0 XML output document:

```

<dict>
  <key>Display Name</key>
  <string>DDF Status</string>
  <key>Value</key>
  <string>STARTD</string>

```

```

</key>Hint</key>
</string />
</dict>

```

```

<?xml version="1.0" encoding="UTF-8" ?>
<plist version="1.0">
<dict>
  <key>Document Type Name</key>
  <string>Data Server Configuration Output</string>
  <key>Document Type Major Version</key>
  <integer>2</integer>
  <key>Document Type Minor Version</key>
  <integer>0</integer>
  <key>Data Server Product Name</key>
  <string>DSN</string>
  <key>Data Server Product Version</key>
  <string>12.1.5</string>
  <key>Data Server Major Version</key>
  <integer>12</integer>
  <key>Data Server Minor Version</key>
  <integer>1</integer>
  <key>Data Server Platform</key>
  <string>z/OS</string>
  <key>Document Locale</key>
  <string>en_US</string>
  <key>DB2 Subsystem Specific Information</key>
  <dict>
    <key>Display Name</key>
    <string>DB2 Subsystem Specific Information</string>
    <key>DB2A</key>
    <dict>
      <key>Display Name</key>
      <string>DB2A</string>
      <key>DB2 Subsystem Status Information</key>
      <dict>
        <key>Display Name</key>
        <string>DB2 Subsystem Status Information</string>
        <key>DB2 Member Identifier</key>
        ...
        <key>DB2 Member Name</key>
        ...
        <key>DB2 Command Prefix</key>
        ...
        <key>DB2 Status</key>
        ...
        <key>DB2 System Level</key>
        ...
        <key>System Name</key>
        ...
        <key>IRLM Subsystem Name</key>
        ...
        <key>IRLM Procedure Name</key>
        ...
        <key>Code Level</key>
        ...
        <key>SPE Apar</key>
        ...
        <key>Migration Eligible</key>
        ...
        <key>Migration Readiness Status</key>
        ...
        <key>Migration Readiness Reason</key>
        ...
        <key>Hint</key>
        ...
      </dict>
    </dict>
  <key>DB2 Subsystem Parameters</key>
  <dict>...</dict>
  <key>DB2 Distributed Access Information</key>
  <dict>
    <key>Display Name</key>
    <string>DB2 Distributed Access Information</string>
    <key>DDF Status</key> ...
    <key>Location Name</key> ...
    <key>LU Name</key> ...
    <key>Generic LU Name</key> ...
    <key>TCP/IP Port</key> ...
    <key>Secure Port</key> ...
    <key>Resynchronization Port</key> ...
    <key>IP Name</key> ...
    <key>IPv4 Address</key> ...
  </dict>

```

```

<key>IPv6 Address</key> ...
<key>SQL Domain</key> ...
<key>DT - DDF Thread Value</key> ...
<key>CONDBAT - Maximum Inbound Connections</key> ...
<key>MDBAT - Maximum Concurrent Active DBATs</key> ...
<key>ADBAT - Active DBATs</key> ...
<key>QUEDBAT - Times that ADBAT Reached MDBAT Limit</key> ...
<key>INADBAT - Inactive DBATs (Type 1)</key> ...
<key>CONQUED - Queued Connections</key> ...
<key>DSCDBAT - Pooled DBATs</key> ...
<key>INACONN - Inactive Connections (Type 2)</key> ...
<key>Hint</key><string></string>
</dict>
<key>Active Log Data Set Information</key>
<dict>...</dict>
<key>Time of Last DB2 Restart</key>
<dict>...</dict>
<key>Resource Limit Facility Information</key>
<dict>
  <key>Display Name</key>
  <string>Resource Limit Facility Information</string>
  <key>RLF Status</key>
  <dict>
    <key>Display Name</key>
    <string>RLF Status</string>
    <key>Value</key><string>Active</string>
    <key>Hint</key><string />
  </dict>
  <key>RLF Table Names</key>
  <dict>
    <key>Display Name</key>
    <string>RLF Table Names</string>
    <key>Value</key>
    <array>
      <string>SYSADM.DSNRLST01</string>
    </array>
    <key>Hint</key><string />
  </dict>
  <key>Hint</key><string />
</dict>
<key>Connected DB2 Subsystem</key>
<dict>...</dict>
<key>Hint</key><string />
</dict>
<key>Hint</key><string />
</dict>
</dict>
</plist>

```

Example 7

This example shows a fragment of a Version 2.0 XML output document for the GET_CONFIG stored procedure in a data sharing system with two Db2 members, DB2A and DB2B. An XML input document is not passed to the stored procedure. The ellipsis (..) represent a dictionary entry that is comprised of **Display Name**, **Value**, and **Hint**, as in the following example, or an entry that is the same as the corresponding entry in a Version 1.0 XML output document:

```

<dict>
  <key>Display Name</key>
  <string>DDF Status</string>
  <key>Value</key>
  <string>STARTD</string>
  <key>Hint</key>
  <string />
</dict>

```

```

<?xml version="1.0" encoding="UTF-8" ?>
<plist version="1.0">
<dict>
  <key>Document Type Name</key>
  <string>Data Server Configuration Output</string>
  <key>Document Type Major Version</key>
  <integer>2</integer>
  <key>Document Type Minor Version</key>
  <integer>0</integer>
  <key>Data Server Product Name</key>
  <string>DSN</string>
  <key>Data Server Product Version</key>
  <string>12.1.5</string>

```

```

<key>Data Server Major Version</key>
<integer>12</integer>
<key>Data Server Minor Version</key>
<integer>1</integer>
<key>Data Server Platform</key>
<string>z/OS</string>
<key>Document Locale</key>
<string>en_US</string>
<key>Common Data Sharing Group Information</key>
<dict>
  <key>Display Name</key>
  <string>Common Data Sharing Group Information</string>
  <key>Data Sharing Group Name</key>
  <dict>...</dict>
  <key>Data Sharing Group Catalog Level</key>
  <dict>...</dict>
  <key>Data Sharing Group Current Function Level</key>
  <dict>...</dict>
  <key>Data Sharing Group Highest Activated Function Level</key>
  <dict>...</dict>
  <key>Data Sharing Group Highest Possible Function Level</
key>
  <dict>...</dict>
  <key>Data Sharing Group Protocol Level</key>
  <dict>...</dict>
  <key>Data Sharing Group Attach Name</key>
  <dict>...</dict>
  <key>Data Sharing Group Encryption Key Label</key>
  <dict>...</dict>
  <key>Migration Readiness Status</key>
  <dict>...</dict>
  <key>Migration Readiness Reason</key>
  <dict>...</dict>
  <key>SCA Structure Size</key>
  <dict>...</dict>
  <key>SCA Status</key>
  <dict>...</dict>
  <key>SCA in Use</key>
  <dict>...</dict>
  <key>LOCK1 Structure Size</key>
  <dict>...</dict>
  <key>Number of Lock Entries</key>
  <dict>...</dict>
  <key>Number of List Entries</key>
  <dict>...</dict>
  <key>List Entries in Use</key>
  <dict>...</dict>
  <key>Hint</key><string />
</dict>
<key>DB2 Subsystem Specific Information</key>
<dict>
  <key>Display Name</key>
  <string>DB2 Subsystem Specific Information</string>
  <key>DB2A</key>
  <dict>
    <key>Display Name</key>
    <string>DB2A</string>
    <key>DB2 Subsystem Status Information</key>
    <dict>
      <key>Display Name</key>
      <string>DB2 Subsystem Status Information</string>
      <key>DB2 Member Identifier</key>
      ...
      <key>DB2 Member Name</key>
      ...
      <key>DB2 Command Prefix</key>
      ...
      <key>DB2 Status</key>
      ...
      <key>DB2 System Level</key>
      ...
      <key>System Name</key>
      ...
      <key>IRLM Subsystem Name</key>
      ...
      <key>IRLM Procedure Name</key>
      ...
      <key>Code Level</key>
      ...
      <key>SPE Apar</key>
      ...
      <key>Migration Eligible</key>
      ...
    </dict>
  </dict>
</dict>

```

```

<key>Hint</key>
...
<key>DB2 Subsystem Parameters</key>
<dict>...</dict>
<key>DB2 Distributed Access Information</key>
<dict>
  <key>Display Name</key>
  <string>DB2 Distributed Access Information</string>
  <key>DDF Status</key> ...
  <key>Location Name</key> ...
  <key>LU Name</key> ...
  <key>Generic LU Name</key> ...
  <key>TCP/IP Port</key> ...
  <key>Secure Port</key> ...
  <key>Resynchronization Port</key> ...
  <key>IP Name</key> ...
  <key>IPv4 Address</key> ...
  <key>IPv6 Address</key> ...
  <key>SQL Domain</key> ...
  <key>Resynchronization Domain</key> ...
  <key>Alias List</key>
  <dict>
    <key>Display Name</key>
    <string>Alias List</string>
    <key>1</key>
    <dict>
      <key>Display Name</key>
      <string>1</string>
      <key>Name</key> ...
      <key>Port</key> ...
      <key>Secure Port</key> ...
      <key>Hint</key><string />
    </dict>
    <key>2</key>
    <dict>
      <key>Display Name</key>
      <string>2</string>
      <key>Name</key> ...
      <key>Port</key> ...
      <key>Secure Port</key> ...
      <key>Hint</key><string />
    </dict>
    <key>Hint</key><string />
  </dict>
  <key>Member IPv4 Address</key> ...
  <key>Member IPv6 Address</key> ...
  <key>DT - DDF Thread Value</key> ...
  <key>CONDBAT - Maximum Inbound Connections</key> ...
  <key>MDBAT - Maximum Concurrent Active DBATs</key> ...
  <key>ADBAT - Active DBATs</key> ...
  <key>QUEDBAT - Times that ADBAT Reached MDBAT Limit</key> ...
  <key>INADBAT - Inactive DBATs (Type 1)</key> ...
  <key>CONQUED - Queued Connections</key> ...
  <key>DSCDBAT - Pooled DBATs</key> ...
  <key>INACONN - Inactive Connections (Type 2)</key> ...
  <key>Location Server List</key>
  <dict>
    <key>Display Name</key>
    <string>Location Server List</string>
    <key>1</key>
    <dict>
      <key>Display Name</key>
      <string>1</string>
      <key>Weight</key> ...
      <key>IPv4 Address</key> ...
      <key>IPv6 Address</key> ...
      <key>Hint</key><string />
    </dict>
    <key>2</key>
    <dict>
      <key>Display Name</key>
      <string>1</string>
      <key>Weight</key> ...
      <key>IPv4 Address</key> ...
      <key>IPv6 Address</key> ...
      <key>Hint</key><string />
    </dict>
    <key>Hint</key><string />
  </dict>
  <key>Hint</key><string></string>
</dict>
<key>Active Log Data Set Information</key>

```



```

</dict>...</dict>
<key>Time of Last DB2 Restart</key>
</dict>...</dict>
<key>Resource Limit Facility Information</key>
<dict>
  <key>Display Name</key>
  <string>Resource Limit Facility Information</string>
  <key>RLF Status</key>
  <dict>
    <key>Display Name</key>
    <string>RLF Status</string>
    <key>Value</key><string>Active</string>
    <key>Hint</key><string />
  </dict>
  <key>RLF Table Names</key>
  <dict>
    <key>Display Name</key>
    <string>RLF Table Names</string>
    <key>Value</key>
    <array>
      <string>SYSADM.DSNRLST01</string>
    </array>
    <key>Hint</key><string />
  </dict>
  <key>Hint</key><string />
</dict>
<key>Connected DB2 Subsystem</key>
<dict>...</dict>
<key>Hint</key><string />
</dict>
<key>DB2B</key>
<dict>
  --- This dictionary entry describes the second DB2
  member: DB2B. Its format is the same as that
  of member DB2A. ---
</dict>
<key>Hint</key><string />
</dict>
</dict>
</plist>

```

```

<key>Data Sharing Group Level</key>
<dict>
  <key>Display Name</key>
  <string>Data Sharing Group Level</string><key>Value</key>
  <string>V12R1M500</string>
  <key>Hint</key><string/>
</dict>
<key>Data Sharing Group Current Function Level</key>
<dict>
  <key>Display Name</key>
  <string>Data Sharing Group Current Function Level</string>
  <key>Value</key><string>V12R1M100</string>
  <key>Hint</key><string/>
</dict>
<key>Data Sharing Group Highest Activated Function Level</key>
<dict>
  <key>Display Name</key>
  <string>Data Sharing Group Highest Activated Function Level</string>
  <key>Value</key><string>V12R1M100</string>
  <key>Hint</key><string/>
</dict>
<key>Data Sharing Group Highest Possible Function Level</key>
<dict>
  <key>Display Name</key>
  <string>Data Sharing Group Highest Possible Function Level</string>
  <key>Value</key><string>V12R1M100</string>
  <key>Hint</key><string/>
</dict>

```

GUPI

Related concepts

[Common SQL API stored procedures \(Db2 Administration Guide\)](#)

GET_MESSAGE stored procedure

The GET_MESSAGE stored procedure returns the short message text for an SQLCODE.

GUI

The GET_MESSAGE stored procedure supports SBCS CCSID only. That is, all data (input and output) must exist in Unicode CCSID 367.

Support for Katakana CCSID 290 is limited. Any user-specific information specified in the `xml_input` document (such as the string input for SQLCODE and Message Tokens) must contain only valid EBCDIC CCSID 37 characters, and these EBCDIC characters must exist in Unicode CCSID 367. Likewise, any requested information that is converted to Unicode CCSID 367 and written to the `xml_output` document, must also contain only valid EBCDIC CCSID 37 characters, and these EBCDIC characters must exist in Unicode CCSID 367.

Authorization

To execute the CALL statement, the owner of the package or plan that contains the CALL statement must have EXECUTE privilege on the GET_MESSAGE stored procedure.

Syntax

The following syntax diagram shows the SQL CALL statement for invoking this stored procedure:

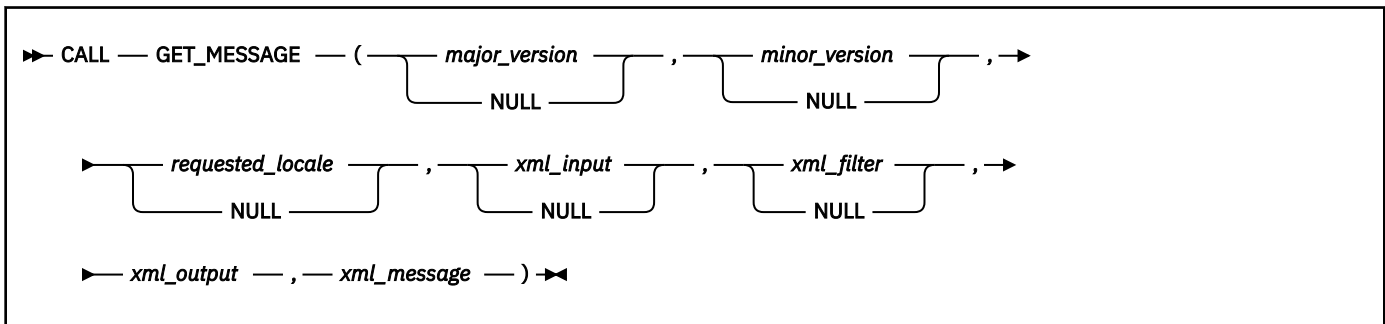

The schema is SYSPROC.

Option descriptions

major_version

An input and output parameter of type INTEGER that indicates the major document version. On input, this parameter indicates the major document version that you support for the XML documents that are passed as parameters in the stored procedure (*xml_input*, *xml_output*, and *xml_message*). The stored procedure processes all XML documents in the specified version, or returns an error (-20457) if the version is invalid.

On output, this parameter specifies the highest major document version that is supported by the stored procedure. To determine the highest supported document version, specify NULL for this input parameter and all other required parameters. Currently, the highest and only major document version that is supported is 1.

If the XML document in the *xml_input* parameter specifies the **Document Type Major Version** key, the value for that key must be equal to the value provided in the *major_version* parameter, or an error (+20458) is raised.

This parameter is used in conjunction with the *minor_version* parameter. Therefore, you must specify both parameters together. For example, you must specify both as either NULL, or non-NULL.

minor_version

An input and output parameter of type INTEGER that indicates the minor document version. On input, this parameter specifies the minor document version that you support for the XML documents that

are passed as parameters for this stored procedure (*xml_input*, *xml_output*, and *xml_message*). The stored procedure processes all XML documents in the specified version, or returns an error (-20457) if the version is invalid.

On output, this parameter indicates the highest minor document version that is supported for the highest supported major version. To determine the highest supported document version, specify NULL for this input parameter and all other required parameters. Currently, the highest and only minor document version that is supported is 0 (zero).

If the XML document in the *xml_input* parameter specifies the **Document Type Minor Version** key, the value for that key must be equal to the value provided in the *minor_version* parameter, or an error (+20458) is raised.

This parameter is used in conjunction with the *major_version* parameter. Therefore, you must specify both parameters together. For example, you must specify both as either NULL, or non-NULL.

requested_locale

An input parameter of type VARCHAR(33) that specifies a locale. If the specified language is supported on the server, translated content is returned in the *xml_output* and *xml_message* parameters. Otherwise, content is returned in the default language. Only the language and possibly the territory information is used from the locale. The locale is not used to format numbers or influence the document encoding. For example, key names are not translated. The only translated portion of the XML output and XML message documents are **Display Name**, **Display Unit**, and **Hint**. The value might be globalized where applicable. You should always compare the requested language to the language that is used in the XML output document (see the **Document Locale** entry in the XML output document).

Currently, the supported values for *requested_locale* are en_US and NULL. If you specify a null value, the result is the same as specifying en_US.

xml_input

An input parameter of type BLOB(2G) that specifies an XML input document of type Data Server Message Input in UTF-8 that contains input values for the stored procedure.

For this stored procedure, the general structure of an XML input document is as follows:

```
<?xml version="1.0" encoding="UTF-8"?>
<plist version="1.0">
  <dict>
    <key>Document Type Name</key><string>Data Server Message Input</string>
    <key>Document Type Major Version</key><integer>1</integer>
    <key>Document Type Minor Version</key><integer>0</integer>
    <key>Document Locale</key><string>en_US</string>
    <key>Complete</key><false/>
    <key>Required Parameters</key>
    <dict>
      <key>SQLCODE</key>
      <dict>
        <key>Value</key><integer>sqlcode</integer>
      </dict>
    </dict>
    <key>Optional Parameters</key>
    <dict>
      <key>Message Tokens</key>
      <dict>
        <key>Value</key>
        <array>
          <string>token1 in SQLCA</string>
          <string>token2 in SQLCA</string>
        </array>
      </dict>
    </dict>
  </dict>
</plist>
```

For an example of an XML input document that will not run in Complete mode, see [“Example 2” on page 945](#).

Complete mode: For an example of an XML input document that is returned by the *xml_output* parameter when the stored procedure is running in Complete mode, see “[Example 1](#)” on page 944 in the Examples section.

xml_filter

An input parameter of type BLOB(4K) in UTF-8 that specifies a valid XPath query string. Use a filter when you want to retrieve a single value from an XML output document. For more information, see [XPath expressions for filtering output \(Db2 Administration Guide\)](#).

The following example selects the value for the short message text from the XML output document:

```
/plist/dict/key[.='Short Message Text']/following-sibling::dict[1]/key[.='Value']/following-sibling::string[1]
```

If the key is not followed by the specified sibling, an error is returned.

xml_output

An output parameter of type BLOB(2G) that returns a complete XML output document of type Data Server Message Output in UTF-8. If a filter is specified, this parameter returns a string value. If the stored procedure is unable to return a complete output document (for example, if a processing error occurs that results in an SQL warning or error), this parameter is set to NULL.

For an example of an XML output document, see “[Example 3](#)” on page 945.

xml_message

An output parameter of type BLOB(64K) that returns a complete XML output document of type Data Server Message in UTF-8 that provides detailed information about an SQL warning condition. This document is returned when a call to the procedure results in an SQL warning, and the warning message indicates that additional information is returned in the XML message output document. If the warning message does not indicate that additional information is returned, then this parameter is set to NULL.

For an example of an XML message document, see “[Example 4](#)” on page 946.

Example

Example 1

The following example shows an XML input document that is returned by the *xml_output* parameter when the stored procedure is running in Complete mode.

```
<?xml version="1.0" encoding="UTF-8" ?>
<plist version="1.0">
  <dict>
    <key>Document Type Name</key>
    <string>Data Server Message Input</string>
    <key>Document Type Major Version</key>
    <integer>1</integer>
    <key>Document Type Minor Version</key>
    <integer>0</integer>
    <key>Document Locale</key>
    <string>en_US</string>
    <key>Required Parameters</key>
    <dict>
      <key>Display Name</key>
      <string>Required Parameters</string>
      <key>SQLCODE</key>
      <dict>
        <key>Display Name</key>
        <string>SQLCODE</string>
        <key>Value</key>
        <integer />
        <key>Hint</key>
        <string />
      </dict>
      <key>Hint</key>
      <string />
    </dict>
    <key>Optional Parameters</key>
    <dict>
      <key>Display Name</key>
      <string>Optional Parameters</string>
```

```

    <key>Message Tokens</key>
    <dict>
      <key>Display Name</key>
      <string>Message Tokens</string>
      <key>Value</key>
      <array>
        <string />
      </array>
      <key>Hint</key>
      <string />
    </dict>
  <key>Hint</key>
  <string />
</dict>
</dict>
</plist>

```

Example 2

The following example shows a complete sample of an XML input document for the GET_MESSAGE stored procedure.

```

<?xml version="1.0" encoding="UTF-8"?>
<plist version="1.0">
  <dict>
    <key>Document Type Name</key>
    <string>Data Server Message Input</string>
    <key>Document Type Major Version</key><integer>1</integer>
    <key>Document Type Minor Version</key><integer>0</integer>
    <key>Document Locale</key><string>en_US</string>
    <key>Required Parameters</key>
    <dict>
      <key>SQLCODE</key>
      <dict>
        <key>Value</key><integer>-104</integer>
      </dict>
    </dict>
    <key>Optional Parameters</key>
    <dict>
      <key>Message Tokens</key>
      <dict>
        <key>Value</key>
        <array>
          <string>X</string>
          <string>( . LIKE AS</string>
        </array>
      </dict>
    </dict>
  </dict>
</plist>

```

Example 3

The following example shows a complete sample of an XML output document for the GET_MESSAGE stored procedure. The short message text for an SQLCODE will be encapsulated in a dictionary entry, which is comprised of **Display Name**, **Value**, and **Hint**.

```

<?xml version="1.0" encoding="UTF-8"?>
<plist version="1.0">
  <dict>
    <key>Document Type Name</key>
    <string>Data Server Message Output</string>
    <key>Document Type Major Version</key><integer>1</integer>
    <key>Document Type Minor Version</key><integer>0</integer>
    <key>Data Server Product Name</key><string>DSN</string>
    <key>Data Server Product Version</key><string>9.1.5</string>
    <key>Data Server Major Version</key><integer>9</integer>
    <key>Data Server Minor Version</key><integer>1</integer>
    <key>Data Server Platform</key><string>z/OS</string>
    <key>Document Locale</key><string>en_US</string>

    <key>Short Message Text</key>
    <dict>
      <key>Display Name</key><string>Short Message Text</string>
      <key>Hint</key><string />
    </dict>
  </dict>
</plist>

```

Example 4

The following example shows a sample XML message document for the GET_MESSAGE stored procedure. Similar to an XML output document, the details about an SQL warning condition will be encapsulated in a dictionary entry, which is comprised of **Display Name**, **Value**, and **Hint**.

```
<?xml version="1.0" encoding="UTF-8" ?>
<plist version="1.0">
  <dict>
    <key>Document Type Name</key><string>Data Server Message</string>
    <key>Document Type Major Version</key><integer>1</integer>
    <key>Document Type Minor Version</key><integer>0</integer>
    <key>Data Server Product Name</key><string>DSN</string>
    <key>Data Server Product Version</key><string>9.1.5</string>
    <key>Data Server Major Version</key><integer>9</integer>
    <key>Data Server Minor Version</key><integer>1</integer>
    <key>Data Server Platform</key><string>z/OS</string>
    <key>Document Locale</key><string>en_US</string>
    <key>Short Message Text</key>
    <dict>
      <key>Display Name</key><string>Short Message Text</string>
      <key>Value</key>
      <string>DSNA630I DSNADMGM A PARAMETER FORMAT OR CONTENT ERROR WAS FOUND.
        The value for key 'Document Type Minor Version' is '2'. It does
        not match the value '0', which was specified for parameter 2 of
        the stored procedure. Both values must be equal.</string>
      <key>Hint</key><string />
    </dict>
  </dict>
</plist>
```

Example 5

This example shows a simple and static Java program that calls the GET_MESSAGE stored procedure with an XML input document and an XPath that queries the short message text of an SQLCODE.

The XML input document is initially saved as a file called `xml_input.xml` that is in the same directory where the GetMessageDriver class resides. This sample program uses the following `xml_input.xml` file:

```
<?xml version="1.0" encoding="UTF-8" ?>
<plist version="1.0">
  <dict>
    <key>Document Type Name</key>
    <string>Data Server Message Input</string>
    <key>Document Type Major Version</key>
    <integer>1</integer>
    <key>Document Type Minor Version</key>
    <integer>0</integer>
    <key>Document Locale</key>
    <string>en_US</string>
    <key>Complete</key>
    <false />
    <key>Required Parameters</key>
    <dict>
      <key>SQLCODE</key>
      <dict>
        <key>Value</key>
        <integer>-204</integer>
      </dict>
    </dict>
    <key>Optional Parameters</key>
    <dict>
      <key>Message Tokens</key>
      <dict>
        <key>Value</key>
        <array>
          <string>SYSIBM.DDF_CONFIG</string>
        </array>
      </dict>
    </dict>
  </dict>
</plist>
```

The XPath is statically created as a string object by the program and then converted to a BLOB to serve as input for the `xml_filter` parameter. After the stored procedure is called, the `xml_output`

parameter contains only a single string and no XML document. This output is materialized as a file called `xml_output.xml` that is in the same directory where the `GetMessageDriver` class resides.

Sample invocation of the `GET_MESSAGE` stored procedure with a valid XML input document and a valid XPath:

```

//*****
// Licensed Materials - Property of IBM
// 5635-DB2
// (C) COPYRIGHT 1982, 2006 IBM Corp. All Rights Reserved.
//
// STATUS = Version 9
//*****
// Source file name: GetSystemDriver.java
//
// Sample: How to call SYSPROC.GET_SYSTEM_INFO with a valid XML input document
// and a valid XPath to extract the operating system name and release.
//
// The user runs the program by issuing:
// java GetSystemDriver <alias or //server/database> <userid> <password>
//
// The arguments are:
// <alias> - DB2 subsystem alias for type 2 or //server/database for type 4
// connectivity
// <userid> - user ID to connect as
// <password> - password to connect with
//*****
import java.io.*;
import java.sql.*;

public class GetSystemDriver
{
    public static void main (String[] args)
    {
        Connection con = null;
        CallableStatement cstmt = null;
        String driver = "com.ibm.db2.jcc.DB2Driver";
        String url = "jdbc:db2:";
        String userid = null;
        String password = null;

        // Parse arguments
        if (args.length != 3)
        {
            System.err.println("Usage: GetSystemDriver <alias or //server/database>
<userid> <password>");
            System.err.println("where <alias or //server/database> is DB2 subsystem
alias or //server/database for type 4 connectivity");
            System.err.println(" <userid> is user ID to connect as");
            System.err.println(" <password> is password to connect with");
            return;
        }
        url += args[0];
        userid = args[1];
        password = args[2];

        try {
            String str_xmlfilter = new String(
                "/plist/dict/key[.='Operating System Information']/following-sibling::
dict[1]" +
                "/key[.='Name and Release']/following-sibling::dict[1]" +
                "/key[.='Value']/following-sibling::string[1]");

            // Convert XML_FILTER to byte array to pass as BLOB
            byte[] xml_filter = str_xmlfilter.getBytes("UTF-8");

            // Read XML_INPUT from file
            File fptr = new File("xml_input.xml");

            int file_length = (int)fptr.length();
            byte[] xml_input = new byte[file_length];

            FileInputStream instream = new FileInputStream(fptr);
            int tot_bytes = instream.read(xml_input,0, xml_input.length);
            if (tot_bytes == -1) {
                System.out.println("Error during file read");
            }
            return;
        }
    }
}

```

```

        instream.close();

// Load the DB2 Universal JDBC Driver
Class.forName(driver);

// Connect to database
con = DriverManager.getConnection(url, userid, password);
con.setAutoCommit(false);

cstmt = con.prepareCall("CALL SYSPROC.GET_SYSTEM_INFO(?,?,?,?);");

// Major / Minor Version / Requested Locale
cstmt.setInt(1, 1);
cstmt.setInt(2, 1);
cstmt.setString(3, "en_US");

// Input documents
cstmt.setObject(4, xml_input, Types.BLOB);
cstmt.setObject(5, xml_filter, Types.BLOB);

// Output Params
cstmt.registerOutParameter(1, Types.INTEGER);
cstmt.registerOutParameter(2, Types.INTEGER);
cstmt.registerOutParameter(6, Types.BLOB);
cstmt.registerOutParameter(7, Types.BLOB);

cstmt.execute();
con.commit();

SQLWarning ctstmt_warning = cstmt.getWarnings();
if (ctstmt_warning != null) {
    System.out.println("SQL Warning: " + ctstmt_warning.getMessage());
}
else {
    System.out.println("SQL Warning: None\r\n");
}

System.out.println("Major Version returned " + cstmt.getInt(1) );
System.out.println("Minor Version returned " + cstmt.getInt(2) );

// Get output BLOBs
Blob b_out = cstmt.getBlob(6);

if(b_out != null)
{
    int out_length = (int)b_out.length();
    byte[] bxml_output = new byte[out_length];

    // Open an inputstream on BLOB data
    InputStream instr_out = b_out.getBinaryStream();

    // Copy from inputstream into byte array
    int out_len = instr_out.read(bxml_output, 0, out_length);

    // Write byte array content into FileOutputStream
    FileOutputStream fxml_out = new FileOutputStream("xml_output.xml");
    fxml_out.write(bxml_output, 0, out_length );

    //Close streams
    instr_out.close();
    fxml_out.close();
}

Blob b_msg = cstmt.getBlob(7);

if(b_msg != null)
{
    int msg_length = (int)b_msg.length();
    byte[] bxml_message = new byte[msg_length];

    // Open an inputstream on BLOB data
    InputStream instr_msg = b_msg.getBinaryStream();

    // Copy from inputstream into byte array
    int msg_len = instr_msg.read(bxml_message, 0, msg_length);

    // Write byte array content into FileOutputStream
    FileOutputStream fxml_msg = new FileOutputStream(new File
("xml_message.xml"));
    fxml_msg.write(bxml_message, 0, msg_length);

    //Close streams

```



```

        instr_msg.close();
        fxml_msg.close();
    }
}

catch (SQLException sqle) {
    System.out.println("Error during CALL "
        + " SQLSTATE = " + sqle.getSQLState()
        + " SQLCODE = " + sqle.getErrorCode()
        + " : " + sqle.getMessage());
}

catch (Exception e) {
    System.out.println("Internal Error " + e.toString());
}

finally
{
    if(cstmt != null)
        try { cstmt.close(); } catch ( SQLException sqle)
    { sqle.printStackTrace(); }
    if(con != null)
        try { con.close(); } catch ( SQLException sqle)
    { sqle.printStackTrace(); }
}
}
}

```

GUPI

Related concepts

[Common SQL API stored procedures \(Db2 Administration Guide\)](#)

GET_SYSTEM_INFO stored procedure

The GET_SYSTEM_INFO stored procedure returns system information about the data server.

GUPI

This system information includes:

- Operating system information
- Product information
- Db2 MEPL
- SYSMOD APPLY status
- Workload Manager (WLM) classification rules that apply to Db2 Workload for subsystem types Db2 and DDF

The GET_SYSTEM_INFO stored procedure supports SBCS CCSID only. That is, all data (input and output) must exist in Unicode CCSID 367.

Support for Katakana CCSID 290 is limited. Any user-specific information specified in the xml_input document (such as the string input for SMPCSI Data Set and SYSMOD) must contain only valid EBCDIC CCSID 37 characters, and these EBCDIC characters must exist in Unicode CCSID 367. Likewise, any requested information that is converted to Unicode CCSID 367 and written to the xml_output document, must also contain only valid EBCDIC CCSID 37 characters, and these EBCDIC characters must exist in Unicode CCSID 367.

Environment

The load module for the GET_SYSTEM_INFO stored procedure, DSNADMGS, must reside in an APF-authorized library. The GET_SYSTEM_INFO stored procedure runs in a WLM-established stored procedures address space, and all of the libraries that are specified in the STEPLIB DD statement must be APF-authorized. TCB=1 is also required.

Authorization

To execute the CALL statement, the owner of the package or plan that contains the CALL statement must have EXECUTE privilege on the GET_SYSTEM_INFO stored procedure.

In addition, because the GET_SYSTEM_INFO stored procedure queries the SMPCSI data set for the status of the SYSMODs, the authorization ID that is associated with the stored procedure address space where the GET_SYSTEM_INFO stored procedure is running must have at least RACF read authority to the SMPCSI data set.

Syntax

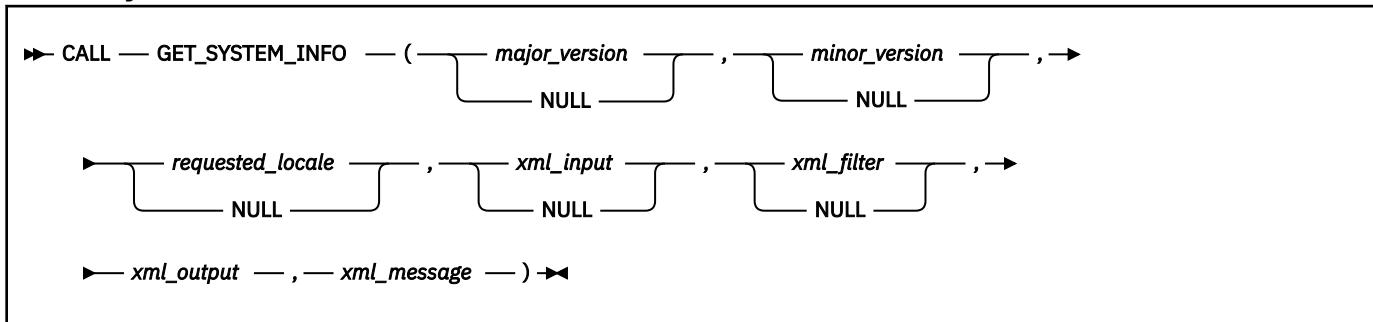

The schema is SYSPROC.

Option descriptions

major_version

An input and output parameter of type INTEGER that indicates the major document version. On input, this parameter indicates the major document version that you support for the XML documents passed as parameters in the stored procedure (*xml_input*, *xml_output*, and *xml_message*). The stored procedure processes all XML documents in the specified version, or returns an error (-20457) if the version is invalid.

On output, this parameter specifies the highest major document version that is supported by the stored procedure. To determine the highest supported document version, specify NULL for this input parameter and all other required parameters. Currently, the highest and the only major document version that is supported is 1.

If the XML document in the *xml_input* parameter specifies a **Document Type Major Version** key, the value for that key must be equal to the value that is provided in the *major_version* parameter, or an error (+20458) is raised.

This parameter is used in conjunction with the *minor_version* parameter. Therefore, you must specify both parameters together. For example, you must specify both as either NULL, or non-NULL.

minor_version

An input and output parameter of type INTEGER that indicates the minor document version. On input, this parameter specifies the minor document version that you support for the XML documents passed as parameters for this stored procedure (*xml_input*, *xml_output*, and *xml_message*). The stored procedure processes all XML documents in the specified version, or returns an error (-20457) if the version is invalid.

On output, this parameter indicates the highest minor document version that is supported for the highest supported major version. To determine the highest supported document version, specify NULL for this input parameter and all other required parameters. The highest minor document version that is supported is 1. Minor document version 0 (zero) is also supported.

If the XML document in the *xml_input* parameter specifies a **Document Type Minor Version** key, the value for that key must be equal to the value that is provided in the *minor_version* parameter, or an error (+20458) is raised.

This parameter is used in conjunction with the *major_version* parameter. Therefore, you must specify both parameters together. For example, you must specify both as either NULL, or non-NULL.

requested_locale

An input parameter of type VARCHAR(33) that specifies a locale. If the specified language is supported on the server, translated content is returned in the *xml_output* and *xml_message* parameters. Otherwise, content is returned in the default language. Only the language and possibly the territory information is used from the locale. The locale is not used to format numbers or influence the document encoding. For example, key names are not translated. The only translated portion of the XML output and XML message documents are **Display Name**, **Display Unit**, and **Hint**. The value might be globalized where applicable. You should always compare the requested language to the language that is used in the XML output document (see the **Document Locale** entry in the XML output document).

Currently, the supported values for *requested_locale* are en_US and NULL. If you specify a null value, the result is the same as specifying en_US.

xml_input

An input parameter of type BLOB(2G) that specifies an XML input document of type Data Server System Input in UTF-8 that contains input values for the stored procedure.

This XML input document is optional. If the XML input document is not passed to the stored procedure, the stored procedure returns the following information by default:

- Operating system information
- Product information
- Db2 MEPL
- Workload Manager (WLM) classification rules for Db2 Workload

This stored procedure supports two types of XML input documents, Version 1.0 or Version 1.1.

For Version 1.0, the general structure of an XML input document is as follows:

```
<?xml version="1.0" encoding="UTF-8"?>
<plist version="1.0">
  <dict>
    <key>Document Type Name</key><string>Data Server System Input</string>
    <key>Document Type Major Version</key><integer>1</integer>
    <key>Document Type Minor Version</key><integer>0</integer>
    <key>Document Locale</key><string>en_US</string>
    <key>Complete</key><false/>
    <key>Optional Parameters</key>
    <dict>
      <key>SMPCSI Data Set</key>
      <dict>
        <key>Value</key><string>SMPCSI data set name</string>
      </dict>
      <key>SYSMOD</key>
      <dict>
        <key>Value</key>
        <array>
          <string>SYSMOD number</string>
          <string>SYSMOD number</string>
        </array>
      </dict>
    </dict>
  </dict>
</plist>
```

For Version 1.1, the general structure of an XML input document is as follows:

```
<?xml version="1.0" encoding="UTF-8"?>
<plist version="1.0">
  <dict>
    <key>Document Type Name</key><string>Data Server System Input</string>
    <key>Document Type Major Version</key><integer>1</integer>
    <key>Document Type Minor Version</key><integer>1</integer>
    <key>Document Locale</key><string>en_US</string>
    <key>Complete</key><false/>
    <key>Optional Parameters</key>
```

```

<dict>
  <key>Include</key>
  <dict>
    <key>Value</key>
    <array>
      <string>Operating System Information</string>
      <string>Product Information</string>
      <string>DB2 MEPL</string>
      <string>Workload Manager (WLM) Classification Rules for
        DB2 Workload</string>
    </array>
  </dict>
  <key>SMPCSI Data Set</key>
  <dict>
    <key>Value</key><string>SMPCSI data set name</string>
  </dict>
  <key>SYSMOD</key>
  <dict>
    <key>Value</key>
    <array>
      <string>SYSMOD number</string>
      <string>SYSMOD number</string>
    </array>
  </dict>
</dict>
</dict>
</plist>

```

Version 1.0: When a Version 1.0 XML input document is passed to the stored procedure, the stored procedure returns the following information in a Version 1.0 XML output document:

- Operating system information
- Product information
- Db2 MEPL
- SYSMOD status (APPLY status for the SYSMODs that are listed in the XML input document)
- Workload Manager (WLM) classification rules for Db2 Workload

To use Version 1.0 of the XML input document you must specify the *major_version* parameter as 1 and the *minor_version* parameter as 0 (zero). You must also specify the **Document Type Name** key, the SMPCSI data set, and the list of SYSMODs.

For an example of a Version 1.0 XML input document for the GET_SYSTEM_INFO stored procedure, see [“Example 3” on page 955](#).

Version 1.1: A Version 1.1 XML input document supports the **Include** parameter, in addition to the **SMPCSI Data Set** and **SYSMOD** parameters that are supported by a Version 1.0 XML input document.

You can use the Version 1.1 XML input document in the following ways:

- To specify which items to include in the XML output document by specifying these items in the **Include** array
- To specify the SMPCSI data set and list of SYSMODs so that the stored procedure returns their APPLY status

To use Version 1.1 of the XML input document, you must specify the *major_version* parameter as 1 and the *minor_version* parameter as 1. You must also specify the **Document Type Name** key, and at least one of the following parameters:

- **Include**
- **SMPCSI Data Set** and **SYSMOD**

If you pass a Version 1.1 XML input document to the stored procedure and specify the **Include**, **SMPCSI Data Set**, and **SYSMOD** parameters, the stored procedure will return the items that you specified in the **Include** array, and the SYSMOD status of the SYSMODs that you specified in the **SYSMOD** array.

If you pass a Version 1.1 XML input document to the stored procedure and specify the **Include** parameter only, the stored procedure will return only the items that you specified in the **Include** array.

If you pass a Version 1.1 XML input document to the stored procedure and specify only the **SMPCSI Data Set** and **SYSMOD** parameters, the stored procedure returns the following information in a Version 1.1 XML output document:

- Operating system information
- Product information
- Db2 MEPL
- SYSMOD status (APPLY status for the SYSMODs that are listed in the XML input document)
- Workload Manager (WLM) classification rules for Db2 Workload

For an example of a complete Version 1.1 XML input document for the GET_SYSTEM_INFO stored procedure, see [“Example 4” on page 955](#).

Complete mode: For examples of Version 1.0 and Version 1.1 XML input documents that are returned by the *xml_output* parameter when the stored procedure is running in Complete mode, see [“Example 1” on page 954](#) and [“Example 2” on page 954](#).

xml_filter

An input parameter of type BLOB(4K) in UTF-8 that specifies a valid XPath query string. Use a filter when you want to retrieve a single value from an XML output document. For more information, see [XPath expressions for filtering output \(Db2 Administration Guide\)](#).

The following example selects the value for the Data Server Product Version from the XML output document:

```
/plist/dict/key[.='Data Server Product Version']/following-sibling::string[1]
```

If the key is not followed by the specified sibling, an error is returned.

xml_output

An output parameter of type BLOB(2G) that returns a complete XML output document of type Data Server System Output in UTF-8. If a filter is specified, this parameter returns a string value. If the stored procedure is unable to return a complete output document (for example, if a processing error occurs that results in an SQL warning or error), this parameter is set to NULL.

The *xml_output* parameter can return either a Version 1.0 or Version 1.1 XML output document depending on the *major_version* and *minor_version* parameters that you specify. For more information about the content differences between the Version 1.0 and Version 1.1 XML output documents, see the option description for the *xml_input* parameter.

A complete XML output document provides the following system information:

- Operating system information
- Product information
- Db2 MEPL
- The APPLY status of SYSMODs
- Workload Manager (WLM) classification rules for Db2 Workload for subsystem types Db2 and DDF

For an example of an XML output document, see [“Example 5” on page 956](#).

xml_message

An output parameter of type BLOB(64K) that returns a complete XML output document of type Data Server Message in UTF-8 that provides detailed information about a SQL warning condition. This document is returned when a call to the stored procedure results in a SQL warning, and the warning message indicates that additional information is returned in the XML message output document. If the warning message does not indicate that additional information is returned, then this parameter is set to NULL.

The `xml_message` parameter can return either a Version 1.0 or Version 1.1 XML message document, depending on the `major_version` and `minor_version` parameters that you specify. The format of a Version 1.0 or Version 1.1. XML message document is similar. For an example of an XML message document, see [“Example 6” on page 958](#).

Examples

Example 1

The following example shows a Version 1.0 XML input document that is returned by the `xml_output` parameter when the stored procedure is running in Complete mode.

```
<?xml version="1.0" encoding="UTF-8" ?>
<plist version="1.0">
  <dict>
    <key>Document Type Name</key><string>Data Server System Input</string>
    <key>Document Type Major Version</key><integer>1</integer>
    <key>Document Type Minor Version</key><integer>0</integer>
    <key>Document Locale</key><string>en_US</string>
    <key>Optional Parameters</key>
    <dict>
      <key>Display Name</key><string>Optional Parameters</string>
      <key>SMPCSI Data Set</key>
      <dict>
        <key>Display Name</key><string>SMPCSI Data Set</string>
        <key>Value</key><string />
        <key>Hint</key><string />
      </dict>
    </dict>
    <key>SYSMOD</key>
    <dict>
      <key>Display Name</key><string>SYSMOD</string>
      <key>Value</key>
      <array>
        <string />
      </array>
      <key>Hint</key><string />
    </dict>
    <key>Hint</key><string />
  </dict>
</plist>
```

Example 2

The following example shows a Version 1.1 XML input document that is returned by the `xml_output` parameter when the stored procedure is running in Complete mode.

```
<?xml version="1.0" encoding="UTF-8" ?>
<plist version="1.0">
  <dict>
    <key>Document Type Name</key><string>Data Server System Input</string>
    <key>Document Type Major Version</key><integer>1</integer>
    <key>Document Type Minor Version</key><integer>1</integer>
    <key>Document Locale</key><string>en_US</string>
    <key>Optional Parameters</key>
    <dict>
      <key>Display Name</key><string>Optional Parameters</string>
      <key>Include</key>
      <dict>
        <key>Display Name</key><string>Include</string>
        <key>Value</key>
        <array>
          <string>Operating System Information</string>
          <string>Product Information</string>
          <string>DB2 MEPL</string>
          <string>Workload Manager (WLM) Classification Rules for
            DB2 Workload</string>
        </array>
        <key>Hint</key><string />
      </dict>
    </dict>
    <key>SMPCSI Data Set</key>
    <dict>
      <key>Display Name</key><string>SMPCSI Data Set</string>
      <key>Value</key><string />
      <key>Hint</key><string />
    </dict>
    <key>SYSMOD</key>
  </dict>
</plist>
```

```

        <key>Display Name</key><string>SYSMOD</string>
        <key>Value</key>
        <array>
            <string />
        </array>
        <key>Hint</key><string />
    </dict>
    <key>Hint</key><string />
</dict>
</plist>

```

Example 3

The following example shows a complete sample of a Version 1.0 XML input document for the GET_SYSTEM_INFO stored procedure.

```

<?xml version="1.0" encoding="UTF-8"?>
<plist version="1.0">
<dict>
  <key>Document Type Name</key>
  <string>Data Server System Input</string>
  <key>Document Type Major Version</key><integer>1</integer>
  <key>Document Type Minor Version</key><integer>0</integer>
  <key>Document Locale</key><string>en_US</string>
  <key>Optional Parameters</key>
  <dict>
    <key>SMPCSI Data Set</key>
    <dict>
      <key>Value</key><string>IXM180.GLOBAL.CSI</string>
    </dict>
    <key>SYSMOD</key>
    <dict>
      <key>Value</key>
      <array>
        <string>UK20028</string>
        <string>UK20030</string>
      </array>
    </dict>
  </dict>
</dict>
</plist>

```

You must specify the SMPCSI data set and one or more SYSMODs. SYSMOD status information will be returned for only the SYSMODs that are listed in the **Optional Parameters** section, provided that the SMPCSI data set that you specify is valid.

Example 4

The following example shows a complete sample of a Version 1.1 XML input document for the GET_SYSTEM_INFO stored procedure.

```

<?xml version="1.0" encoding="UTF-8"?>
<plist version="1.0">
<dict>
  <key>Document Type Name</key><string>Data Server System Input</string>
  <key>Document Type Major Version</key><integer>1</integer>
  <key>Document Type Minor Version</key><integer>1</integer>
  <key>Document Locale</key><string>en_US</string>
  <key>Optional Parameters</key>
  <dict>
    <key>Include</key>
    <dict>
      <key>Value</key>
      <array>
        <string>Operating System Information</string>
        <string>Product Information</string>
        <string>DB2 MEPL</string>
        <string>Workload Manager (WLM) Classification Rules for
          DB2 Workload</string>
      </array>
    </dict>
    <key>SMPCSI Data Set</key>
    <dict>
      <key>Value</key><string>IXM180.GLOBAL.CSI</string>
    </dict>
    <key>SYSMOD</key>
    <dict>
      <key>Value</key>

```

```

    <array>
      <string>UK24596</string>
      <string>UK24709</string>
    </array>
  </dict>
</dict>
</dict>
</plist>

```

Example 5

The following example shows a fragment of an XML output document for the GET_SYSTEM_INFO stored procedure. In this example, the ellipsis (. . .) represent a dictionary entry that is comprised of **Display Name**, **Value**, and **Hint**, such as:

```

<dict>
  <key>Display Name</key>
  <string>Name</string>
  <key>Value</key>
  <string>JES2</string>
  <key>Hint</key>
  <string />
</dict>

```

```

<?xml version="1.0" encoding="UTF-8" ?>
<plist version="1.0">
<dict>
  <key>Document Type Name</key>
  <string>Data Server System Output</string>
  <key>Document Type Major Version</key>
  <integer>1</integer>
  <key>Document Type Minor Version</key>
  <integer>1</integer>
  <key>Data Server Product Name</key>
  <string>DSN</string>
  <key>Data Server Product Version</key>
  <string>9.1.5</string>
  <key>Data Server Major Version</key>
  <integer>9</integer>
  <key>Data Server Minor Version</key>
  <integer>1</integer>
  <key>Data Server Platform</key>
  <string>z/OS</string>
  <key>Document Locale</key>
  <string>en_US</string>
  <key>Operating System Information</key>
  <dict>
    <key>Display Name</key><string>Operating System Information</string>
    <key>Name and Release</key>
    ...
  <key>CPU</key>
  <dict>
    <key>Display Name</key><string>CPU</string>
    <key>Model</key>
    ...
    <key>Number of Online CPUs</key>
    ...
    <key>Online CPUs</key>
    <dict>
      <key>Display Name</key><string>Online CPUs</string>
      <key>CPU ID 01</key>
      <dict>
        <key>Display Name</key><string>CPU ID 01</string>
        <key>Serial Number</key>
        ...
        <key>Hint</key><string />
      </dict>
    <key>Hint</key><string />
  </dict>
  <key>Hint</key><string />
</dict>
  <key>Real Storage Size</key>
  <dict>
    <key>Display Name</key><string>Real Storage Size</string>
    <key>Value</key><integer>256</integer>
    <key>Display Unit</key><string>MB</string>
    <key>Hint</key><string />
  </dict>
  <key>Sysplex Name</key>

```



```

<dict>
  <key>Display Name</key>
  <string>Sysplex Name</string>
  <key>Value</key>
  <string>XESDEV</string>
  <key>Hint</key>
  <string />
</dict>
</dict>

<key>Product Information</key>
<dict>
  <key>Display Name</key><string>Product Information</string>
  <key>Primary Job Entry Subsystem</key>
  <dict>
    <key>Display Name</key><string>Primary Job Entry Subsystem</string>
    <key>Name</key>
    ...
    <key>Release</key>
    ...
    <key>Node Name</key>
    ...
    <key>Held Output Class</key>
    ...
    <key>Hint</key><string />
  </dict>
  <key>Security Software</key>
  <dict>
    <key>Display Name</key><string>Security Software</string>
    <key>Name</key>
    ...
    <key>FMID</key>
    ...
    <key>Hint</key><string />
  </dict>
  <key>DFSMS Release</key>
  ...
  <key>TSO Release</key>
  ...
  <key>VTAM Release</key>
  ...
  <key>Hint</key><string />
</dict>

<key>DB2 MEPL</key>
<dict>
  <key>Display Name</key><string>DB2 MEPL</string>
  <key>DSNUTILB</key>
  <dict>
    <key>Display Name</key><string>DSNUTILB</string>
    <key>DSNAA</key>
    <dict>
      <key>Display Name</key><string>DSNAA</string>
      <key>PTF Level</key>
      ...
      <key>PTF Apply Date</key>
      ...
      <key>Hint</key><string />
    </dict>
  </dict>

  --- This is only a fragment of the utility modules that
      are returned by the GET_SYSTEM_INFO stored procedure. ---

  <key>Hint</key><string></string>
</dict>

  --- This is only a fragment of the
      DB2 MEPL information that is returned by
      the GET_SYSTEM_INFO stored procedure. ---

</dict>

<key>SYSMOD Status</key>
<dict>
  <key>Display Name</key><string>SYSMOD Status</string>
  <key>AA15195</key>
  <dict>
    <key>Display Name</key><string>AA15195</string>
    <key>Apply</key>
    ...
    <key>Apply Date</key>
    ...

```

```

    <key>Hint</key><string />
  </dict>

  --- This is only a fragment of the SYSMOD
  status information that is returned by
  the GET_SYSTEM_INFO stored procedure. ---

</dict>

<key>Workload Manager (WLM) Classification Rules for DB2 Workload</key>
<dict>
  <key>Display Name</key>
  <string>Workload Manager (WLM) Classification Rules for DB2 Workload</string>
  <key>DB2</key>
  <dict>
    <key>Display Name</key><string>DB2</string>
    <key>Hint</key><string />
  </dict>
  <key>DDF</key>
  <dict>
    <key>Display Name</key><string>DDF</string>
    <key>1.1.1</key>
    <dict>
      <key>Display Name</key><string>1.1.1</string>
      <key>Nesting Level</key>
      ...
      <key>Qualifier Type</key>
      ...
      <key>Qualifier Type Full Name</key>
      ...
      <key>Qualifier Name</key>
      ...
      <key>Start Position</key>
      ...
      <key>Service Class</key>
      ...
      <key>Report Class</key>
      ...
      <key>Hint</key><string />
    </dict>
    <key>2.1.1</key>
    <dict>
      --- This dictionary entry describes the second classification
      rule, and its format is the same as that of 1.1.1 above,
      which describes the first classification rule. ---
    </dict>
    <key>Hint</key><string />
  </dict>
  <key>Hint</key><string />
</dict>
</plist>

```

Example 6

The following example shows a sample XML message document for the GET_SYSTEM_INFO stored procedure. Similar to an XML output document, the details about an SQL warning condition will be encapsulated in a dictionary entry, which is comprised of **Display Name**, **Value**, and **Hint**.

```

<?xml version="1.0" encoding="UTF-8" ?>
<plist version="1.0">
  <dict>
    <key>Document Type Name</key><string>Data Server Message</string>
    <key>Document Type Major Version</key><integer>1</integer>
    <key>Document Type Minor Version</key><integer>1</integer>
    <key>Data Server Product Name</key><string>DSN</string>
    <key>Data Server Product Version</key><string>9.1.5</string>
    <key>Data Server Major Version</key><integer>9</integer>
    <key>Data Server Minor Version</key><integer>1</integer>
    <key>Data Server Platform</key><string>z/OS</string>
    <key>Document Locale</key><string>en_US</string>
    <key>Short Message Text</key>
    <dict>
      <key>Display Name</key><string>Short Message Text</string>
      <key>Value</key>
      <string>DSNA647I DSNADMGS INVOCATION OF GIMAPI FAILED. Error processing
      command: QUERY . RC=12 CC=50504. GIM54701W ALLOCATION FAILED FOR
      SMPCSI - IKJ56228I DATA SET IXM180.GLOBAL.CSI NOT IN CATALOG OR
      CATALOG CAN NOT BE ACCESSED. GIM44232I GIMMPVIA - DYNAMIC
      ALLOCATION FAILED FOR THE GLOBAL ZONE, DATA SET IXM180.GLOBAL.CSI.
    </dict>
  </dict>
</plist>

```

```

                GIM50504S ** OPEN PROCESSING FAILED FOR THE GLOBAL ZONE.</string>
        <key>Hint</key><string />
    </dict>
</dict>
</plist>

```

Example 7

This example shows a simple and static Java program that calls the GET_SYSTEM_INFO stored procedure with an XML input document and an XPath that queries the value of the operating system name and release.

The XML input document is initially saved as a file called xml_input.xml that is in the same directory where the GetSystemDriver class resides. This sample program uses the following xml_input.xml file:

```

<?xml version="1.0" encoding="UTF-8" ?>
<plist version="1.0">
  <dict>
    <key>Document Type Name</key>
    <string>Data Server System Input</string>
    <key>Document Type Major Version</key>
    <integer>1</integer>
    <key>Document Type Minor Version</key>
    <integer>1</integer>
    <key>Document Locale</key>
    <string>en_US</string>
    <key>Optional Parameters</key>
    <dict>
      <key>Include</key>
      <dict>
        <key>Value</key>
        <array>
          <string>Operating System Information</string>
        </array>
      </dict>
    </dict>
  </dict>
</plist>

```

The XPath is statically created as a string object by the program and then converted to a BLOB to serve as input for the *xml_filter* parameter. After the stored procedure is called, the *xml_output* parameter contains only a single string and no XML document. This output is materialized as a file called xml_output.xml that is in the same directory where the GetSystemDriver class resides.

Sample invocation of the GET_SYSTEM_INFO stored procedure with a valid XML input document and a valid XPath:

```

//*****
// Licensed Materials - Property of IBM
// 5635-DB2
// (C) COPYRIGHT 1982, 2006 IBM Corp. All Rights Reserved.
//
// STATUS = Version 9
//*****
// Source file name: GetSystemDriver.java
//
// Sample: How to call SYSPROC.GET_SYSTEM_INFO with a valid XML input document
// and a valid XPath to extract the operating system name and release.
//
// The user runs the program by issuing:
// java GetSystemDriver <alias or //server/database> <userid> <password>
//
// The arguments are:
// <alias> - DB2 subsystem alias for type 2 or //server/database for type 4
// connectivity
// <userid> - user ID to connect as
// <password> - password to connect with
//*****
import java.io.*;
import java.sql.*;

public class GetSystemDriver
{
    public static void main (String[] args)
    {

```

```

Connection con = null;
CallableStatement cstmt = null;
String driver = "com.ibm.db2.jcc.DB2Driver";
String url = "jdbc:db2:";
String userid = null;
String password = null;

// Parse arguments
if (args.length != 3)
{
    System.err.println("Usage: GetSystemDriver <alias or //server/database>
<userid> <password>");
    System.err.println("where <alias or //server/database> is DB2 subsystem
alias or //server/database for type 4 connectivity");
    System.err.println(" <userid> is user ID to connect as");
    System.err.println(" <password> is password to connect with");
    return;
}
url += args[0];
userid = args[1];
password = args[2];

try {
    String str_xmlfilter = new String(
        "/plist/dict/key[.='Operating System Information']/following-sibling::
dict[1]" +
        "/key[.='Name and Release']/following-sibling::dict[1]" +
        "/key[.='Value']/following-sibling::string[1]");

    // Convert XML_FILTER to byte array to pass as BLOB
    byte[] xml_filter = str_xmlfilter.getBytes("UTF-8");

    // Read XML_INPUT from file
    File fptr = new File("xml_input.xml");

    int file_length = (int)fptr.length();
    byte[] xml_input = new byte[file_length];

    FileInputStream instream = new FileInputStream(fptr);
    int tot_bytes = instream.read(xml_input,0, xml_input.length);
    if (tot_bytes == -1) {
        System.out.println("Error during file read");
        return;
    }
    instream.close();

    // Load the DB2 Universal JDBC Driver
    Class.forName(driver);

    // Connect to database
    con = DriverManager.getConnection(url, userid, password);
    con.setAutoCommit(false);

    cstmt = con.prepareCall("CALL SYSPROC.GET_SYSTEM_INFO(?,?,?,?,?,?)");

    // Major / Minor Version / Requested Locale
    cstmt.setInt(1, 1);
    cstmt.setInt(2, 1);
    cstmt.setString(3, "en_US");

    // Input documents
    cstmt.setObject(4, xml_input, Types.BLOB);
    cstmt.setObject(5, xml_filter, Types.BLOB);

    // Output Params
    cstmt.registerOutParameter(1, Types.INTEGER);
    cstmt.registerOutParameter(2, Types.INTEGER);
    cstmt.registerOutParameter(6, Types.BLOB);
    cstmt.registerOutParameter(7, Types.BLOB);

    cstmt.execute();
    con.commit();

    SQLWarning ctstmt_warning = cstmt.getWarnings();
    if (ctstmt_warning != null) {
        System.out.println("SQL Warning: " + ctstmt_warning.getMessage());
    }
    else {
        System.out.println("SQL Warning: None\r\n");
    }
}

```

```

System.out.println("Major Version returned " + cstmt.getInt(1) );
System.out.println("Minor Version returned " + cstmt.getInt(2) );

// Get output BLOBs
Blob b_out = cstmt.getBlob(6);

if(b_out != null)
{
    int out_length = (int)b_out.length();
    byte[] bxml_output = new byte[out_length];

    // Open an inputstream on BLOB data
    InputStream instr_out = b_out.getBinaryStream();

    // Copy from inputstream into byte array
    int out_len = instr_out.read(bxml_output, 0, out_length);

    // Write byte array content into FileOutputStream
    FileOutputStream fxml_out = new FileOutputStream("xml_output.xml");
    fxml_out.write(bxml_output, 0, out_length );

    //Close streams
    instr_out.close();
    fxml_out.close();
}

Blob b_msg = cstmt.getBlob(7);

if(b_msg != null)
{
    int msg_length = (int)b_msg.length();
    byte[] bxml_message = new byte[msg_length];

    // Open an inputstream on BLOB data
    InputStream instr_msg = b_msg.getBinaryStream();

    // Copy from inputstream into byte array
    int msg_len = instr_msg.read(bxml_message, 0, msg_length);

    // Write byte array content into FileOutputStream
    FileOutputStream fxml_msg = new FileOutputStream(new File("xml_message.
xml"));
    fxml_msg.write(bxml_message, 0, msg_length);

    //Close streams
    instr_msg.close();
    fxml_msg.close();
}

}

catch (SQLException sqle) {
    System.out.println("Error during CALL "
        + " SQLSTATE = " + sqle.getSQLState()
        + " SQLCODE = " + sqle.getErrorCode()
        + " : " + sqle.getMessage());
}

catch (Exception e) {
    System.out.println("Internal Error " + e.toString());
}

finally
{
    if(cstmt != null)
        try { cstmt.close(); } catch ( SQLException sqle)
    { sqle.printStackTrace(); }
    if(con != null)
        try { con.close(); } catch ( SQLException sqle)
    { sqle.printStackTrace(); }
}
}
}

```



Related concepts

[Common SQL API stored procedures \(Db2 Administration Guide\)](#)

SET_MAINT_MODE_RECORD_NO_TEMPORALHISTORY stored procedure

The SYSPROC.SET_MAINT_MODE_RECORD_NO_TEMPORALHISTORY stored procedure indicates that Db2 is to disable recording of temporal history for a system-period temporal table and allow an application to specify values for row-begin, row-end, and transaction-start-ID columns on subsequent operations. Db2 continues to generate new values for row-begin, row-end, and transaction-start-ID columns that are not explicitly specified as the target of an assignment clause for a data change statement.

This procedure is not intended for general use. It is intended to be used by products that enable Db2 replication.

Note: [FL 503](#) The SYSPROC.SET_MAINT_MODE_RECORD_NO_TEMPORALHISTORY stored procedure is deprecated at V12R1M503. The procedure will continue to work if you run with APPLCOMPAT set to V12R1M502 or lower, as long as V12R1M502 is supported. The functionality provided by the procedure has been subsumed by the new [SYSIBMADM.REPLICATION_OVERRIDE](#) built-in global variable.

PSPI

Environment

SET_MAINT_MODE_RECORD_NO_TEMPORALHISTORY must run in a WLM-established stored procedure address space.

Authorization

To execute the CALL statement, the owner of the package or plan that contains the CALL statement must have one or more of the following privileges:

- The EXECUTE privilege on the SET_MAINT_MODE_RECORD_NO_TEMPORALHISTORY stored procedure
- Ownership of the stored procedure
- SYSADM authority

Syntax

The following syntax diagram shows the SQL CALL statement for invoking this stored procedure:

```
▶ CALL — SYSPROC.SET_MAINT_MODE_RECORD_NO_TEMPORALHISTORY — ( — ) ▶▶
```

Description

The procedure has no parameters.

The result of the procedure is that recording of temporal history for a system-period temporal table is disabled, and an application is allowed to specify values for row-begin, row-end, and transaction-start-ID columns.

PSPI

SET_PLAN_HINT stored procedure

The SET_PLAN_HINT stored procedure validates, deploys, modifies, or deletes catalog tables rows that influence access path selection for SQL statements.

PSPI The actions that are taken when you call the SET_PLAN_HINT stored procedure depend on a mode value and the type of hint that you specify. You can specify the following modes: [CREATE](#), [DELETE](#), [MODIFY](#) or [VALIDATE](#).

Environment

The SET_PLAN_HINT stored procedure runs in a WLM-established stored procedures address space.

The following staging tables, and related objects, which are created by job DSNTIJRT, must exist for use by the SET_PLAN_HINT stored procedure:

- DSN8BQRY.PLAN_TABLE
- DSN8BQRY.DSN_USER_QUERY_TABLE
- DSN8BQRY.DSN_PREDICAT_TABLE
- DSN8BQRY.DSN_PREDICATE_SELECTIVITY

Authorization

To execute the CALL statement, the owner of the package or plan that contains the CALL statement must have EXECUTE privilege on the SET_PLAN_HINT stored procedure.

Syntax

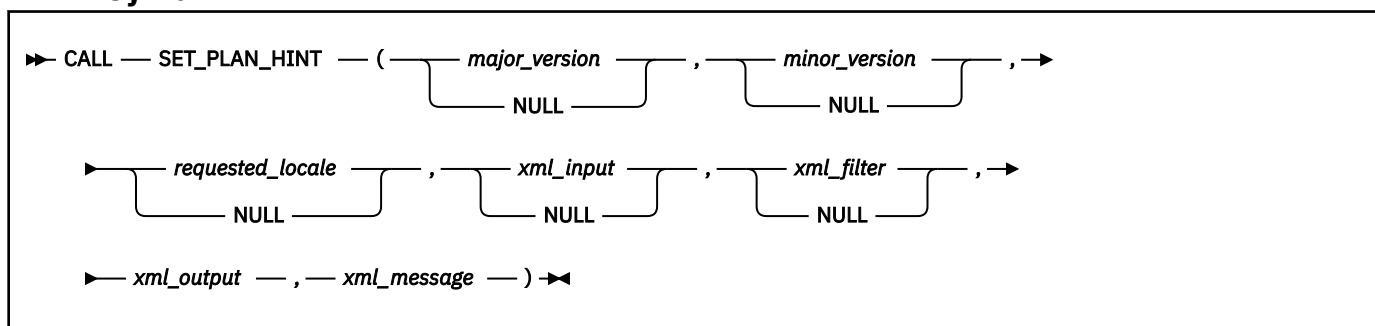

The schema is SYSPROC.

Option descriptions

major_version

An input and output parameter of type INTEGER that indicates the major document version. On input, this parameter indicates the major document version that you support for the XML documents that are passed as parameters in the stored procedure (*xml_input*, *xml_output*, and *xml_message*). The stored procedure processes all XML documents in the specified version, or returns an error (-20457) if the version is invalid.

On output, this parameter specifies the highest major document version that is supported by the procedure. To determine the highest supported document version, specify NULL for this input parameter and all other required parameters. The only supported value is 1.

If the XML document in the *xml_input* parameter specifies the **Document Type Major Version** key, the value for that key must be equal to the value provided in the *major_version* parameter, or an error (+20458) is raised.

This parameter is used in conjunction with the *minor_version* parameter. Therefore, you must specify both parameters together. For example, you must specify both as either NULL, or non-NULL.

minor_version

An input and output parameter of type INTEGER that indicates the minor document version. On input, this parameter specifies the minor document version that you support for the XML documents that are passed as parameters for this stored procedure (*xml_input*, *xml_output*, and *xml_message*). The stored procedure processes all XML documents in the specified version, or returns an error (-20457) if the version is invalid.

On output, this parameter indicates the highest minor document version that is supported for the highest supported major version. To determine the highest supported document version, specify NULL

for this input parameter and all other required parameters. The only minor document version that is supported is 0 (zero).

If the XML document in the *xml_input* parameter specifies the **Document Type Minor Version** key, the value for that key must be equal to the value provided in the *minor_version* parameter, or an error (+20458) is raised.

This parameter is used in conjunction with the *major_version* parameter. Therefore, you must specify both parameters together. For example, you must specify both as either NULL, or non-NULL.

requested_locale

An input parameter of type VARCHAR(33) that specifies a locale. If the specified language is supported on the server, translated content is returned in the *xml_output* and *xml_message* parameters. Otherwise, content is returned in the default language. Only the language and possibly the territory information is used from the locale. The locale is not used to format numbers or influence the document encoding. For example, key names are not translated. The only translated portion of XML output and XML message documents are **Display Name, Display Unit, and Hint**. The value might be globalized where applicable. You should always compare the requested language to the language that is used in the XML output document (see the **Document Locale** entry in the XML output document).

Currently, the supported values for *requested_locale* are en_US and NULL. If you specify a null value, the result is the same as specifying en_US.

xml_input

An input parameter of type BLOB(2G) that specifies an XML input document of type Data Server Hint Management Input in UTF-8 that represents the hint customization. The SET_PLAN_HINT stored procedure does not support Complete mode.

The input document has the following format.

```
<?xml version="1.0" encoding="UTF-8"?>
<plist version="1.0">
<dict>
  <key>Document Type Name</key><string>Data Server Hint Management Input</string>
  <key>Document Type Major Version</key><integer>1</integer>
  <key>Document Type Minor Version</key><integer>0</integer>
  <key>HINT_CUSTOMIZATION</key>
  <dict>
    <key>hint-customization
  </dict>
</dict>
</plist>
```

In the preceding example, *hint-customization* is an XML fragment that describes the customized hint to be generated, validated, or deleted. The following example shows the overview of the format of the hint customization dictionary:

```
<key>HINT_CUSTOMIZATION</key>
<dict>
  <key>DeploymentParameters</key>
  <dict>
  </dict>
</dict>
<key>StatementList</key>
<array>
  <dict>
    <key>DeploymentParameters</key>
    <dict>
    </dict>
    <key>SQLStatement</key>
    <dict>
    </dict>
    <key>ExistingAccessPlanIdentifier</key>
    <dict>
    </dict>
    <key>StatementLevelRules</key>
    <dict>
    </dict>
    <key>PlanLevelRules</key>
    <dict>
    <key>TableAccessRules</key>
```



```

    <array></array>
    <key>JoinSequenceRules</key>
    <array></array>
  </dict>
  <key>PredicateSelectivityInstances</key>
  <array>
  </array>
  <key>ExistingPredicateSelectivityIdentifier</key>
  <dict>
  </dict>
</dict>
</array>
</dict>

```

hint-customization is a dictionary that contains the following keys:

DeploymentParameters

The type of hint, the action for the stored procedure, and the deployment parameters for the hint.

Deployment parameters can also be specified at the statement level, within the [“StatementList”](#) on page 977 array. Statement-level deployment parameters override the global deployment parameters for a particular statement.

The DeploymentParameters dictionary can contain the following keys:

MODE

The MODE value is required. It specifies the hint processing mode and controls the actions taken by the SET_PLAN_HINT stored procedure:

CREATE

Generates a hint in the deployment table. The following table describes the specific actions and required input parameters for different types of hints:

Table 159. Actions by hint type for the SET_PLAN_HINT stored procedure in CREATE mode

Hint type	Action	Required Input Parameters
PLAN_TABLE access path hints	<ol style="list-style-type: none"> 1. A check is completed to ensure that the deployment PLAN_TABLE does not contain an existing hint that has matching values for the following parameters that are specified in the DeploymentParameters dictionary: <ul style="list-style-type: none"> • QUERYNO • APPLNAME • PROGNAME • COLLID • VERSION • OPTHINT • BIND_TIME 2. An existing access path is copied from the source PLAN_TABLE to the deployment PLAN_TABLE, and the information specified in the DeploymentParameters, TableAccessRules, and JoinSequenceRules dictionaries are applied to the copied plan. <ul style="list-style-type: none"> • The existing access path is identified by the parameters specified in the ExistingAccessPathIdentifier dictionary. • The source PLAN_TABLE is <i>schema-name</i>.PLAN_TABLE, where <i>schema-name</i> is the PLAN_SCHEMA value that is specified in the ExistingAccessPlanIdentifier dictionary. • The deployment PLAN_TABLE is the <i>schema-name</i>.PLAN_TABLE, where <i>schema-name</i> is the PLAN_SCHEMA value that is specified in the DeploymentParameters dictionary. 	<ul style="list-style-type: none"> • DeploymentParameters <ul style="list-style-type: none"> – QUERYNO – APPLNAME – PROGNAME – COLLID – VERSION – OPTHINT – PLAN_SCHEMA (schema of the deployment PLAN_TABLE) • ExistingAccessPlanIdentifier <ul style="list-style-type: none"> – QUERYNO – APPLNAME – PROGNAME – COLLID – VERSION – OPTHINT – PLAN_SCHEMA (schema of the source PLAN_TABLE)

Table 159. Actions by hint type for the SET_PLAN_HINT stored procedure in CREATE mode (continued)

Hint type	Action	Required Input Parameters
Statement-level access paths	<p>1. The staging table DSN8BQRY.DSN_USERQUERY_TABLE is populated with the information that is specified in the DeploymentParameters and SQLStatement dictionaries.</p> <p>2. The following command is issued to check that the new hint does not already exist:</p> <pre> BIND QUERY EXPLAININPUTSCHEMA('DSN8BQRY') LOOKUP(YES) </pre> <p>3. If a hint of the same scope does not already exist, an existing access path is copied from the source PLAN_TABLE to the staging table DSN8BQRY.PLAN_TABLE, the information specified in the DeploymentParameters, TableAccessRules, and JoinSequenceRules dictionaries are applied to the copied plan, and the following command is issued:</p> <pre> BIND QUERY EXPLAININPUTSCHEMA('DSN8BQRY') </pre> <ul style="list-style-type: none"> The existing access path is identified by the information that is specified in the ExistingAccessPlanIdentifier dictionary The source PLAN_TABLE is <i>schema-name</i>.PLAN_TABLE, where <i>schema-name</i> is the PLAN_SCHEMA value that is specified in the ExistingAccessPlanIdentifier. 	<ul style="list-style-type: none"> DeploymentParameters <ul style="list-style-type: none"> If HINT_SCOPE=1 (package-level access paths): <ul style="list-style-type: none"> PROGNAME COLLID VERSION HINT_TYPE ('INSTANCE-LEVEL') ExistingAccessPlanIdentifier <ul style="list-style-type: none"> QUERYNO APPLNAME PROGNAME COLLID VERSION PLAN_SCHEMA (schema of the source PLAN_TABLE) SQLStatement <ul style="list-style-type: none"> SQLText

Table 159. Actions by hint type for the SET_PLAN_HINT stored procedure in CREATE mode (continued)

Hint type	Action	Required Input Parameters
Statement-level optimization parameters ^{“1”} on page 976	<ol style="list-style-type: none"> <li data-bbox="345 239 906 401">1. The staging table DSN8BQRY.DSN_USERQUERY_TABLE is populated with the information specified in the DeploymentParameters, SQLStatement, and StatementLevelRules dictionaries. <li data-bbox="345 415 906 478">2. The following command is issued to check that the new hint does not already exist: <div data-bbox="383 495 932 569" style="background-color: #f0f0f0; padding: 5px; margin: 5px 0;"> <pre data-bbox="399 510 769 554">BIND QUERY EXPLAININPUTSCHEMA ('DSN8BQRY') LOOKUP(YES)</pre> </div> <li data-bbox="345 583 906 642">3. If a hint of the same scope does not already exist, the following command is issued: <div data-bbox="383 663 932 737" style="background-color: #f0f0f0; padding: 5px; margin: 5px 0;"> <pre data-bbox="399 678 781 722">BIND QUERY EXPLAININPUTSCHEMA ('DSN8BQRY')</pre> </div> 	<ul style="list-style-type: none"> <li data-bbox="946 239 1252 266">• DeploymentParameters <ul style="list-style-type: none"> <li data-bbox="967 289 1406 352">– If HINT_SCOPE=1 (package-level access paths): <ul style="list-style-type: none"> <li data-bbox="995 369 1166 396">- PROGNAME <li data-bbox="995 413 1110 441">- COLLID <li data-bbox="995 457 1133 485">- VERSION <li data-bbox="967 501 1382 529">– HINT_TYPE ('INSTANCE-LEVEL') <li data-bbox="967 546 1393 609">– INSTANCE_LEVEL_HINT_TYPE ('OPTIMIZATION-PARAMETERS') <li data-bbox="946 625 1406 688">• StatementLevelRules (any one of the following values) <ul style="list-style-type: none"> <li data-bbox="967 705 1083 732">– REOPT <li data-bbox="967 749 1122 777">– STARJOIN <li data-bbox="967 793 1232 821">– MAX_PAR_DEGREE <li data-bbox="967 837 1097 865">– DEGREE <li data-bbox="967 882 1122 909">– SJTABLES <li data-bbox="946 919 1143 947">• SQLStatement <ul style="list-style-type: none"> <li data-bbox="967 963 1094 991">– SQLText

Table 159. Actions by hint type for the SET_PLAN_HINT stored procedure in CREATE mode (continued)

Hint type	Action	Required Input Parameters
Statement-level predicate selectivity overrides	<p>1. The staging table DSN8BQRY.DSN_USERQUERY_TABLE is populated with the information that is specified in the DeploymentParameters and SQLStatement dictionaries.</p> <p>2. The following command is issued to check whether the hint already exists:</p> <pre> BIND QUERY EXPLAININPUTSCHEMA('DSN8BQRY') LOOKUP(YES) </pre> <p>3. If an existing hint of the same scope is found and predicate selectivity override for the query is not in effect, or an existing hint of the same scope is not found:</p> <ol style="list-style-type: none"> If optimization parameters are in effect for the query, the staging table DSN8BQRY.DSN_USERQUERY_TABLE is further updated with the optimization parameters to ensure that the existing optimization parameters are not lost when the BIND QUERY is performed subsequently. The staging table DSN8BQRY.DSN_PREDICAT_TABLE is populated with the original predicate information from the source DSN_PREDICAT_TABLE. <ul style="list-style-type: none"> The source DSN_PREDICAT_TABLE is <i>schema-name</i>.DSN_PREDICAT_TABLE, where <i>schema-name</i> is the PLAN_SCHEMA value that is specified in the ExistingPredicateSelectivityIdentifier dictionary The original predicates of the query are identified by the parameters specified in the ExistingPredicateSelectivityIdentifier dictionary. <p>If the existing hint is an optimization parameter override, the values that define it are inserted in the staging table DSN8BQRY.DSN_USERQUERY_TABLE.</p> <p>If the existing hint is not compatible with the new selectivity override, processing ends.</p> <p>Steps continue in the next row.</p>	<ul style="list-style-type: none"> DeploymentParameters <ul style="list-style-type: none"> HINT_TYPE ('INSTANCE-LEVEL') INSTANCE_LEVEL_HINT_TYPE ('SELECTIVITY-OVERRIDE') If HINT_SCOPE=1 (package-level): <ul style="list-style-type: none"> PROGNAME COLLID VERSION SQLStatement <ul style="list-style-type: none"> SQLText ExistingPredicateSelectivityIdentifier <ul style="list-style-type: none"> QUERYNO PLAN_SCHEMA EXPLAIN_TIME PredicateSelectivityInstances <ul style="list-style-type: none"> QBLOCKNO Predicates: <ul style="list-style-type: none"> PREDNO SelectivityInstances <ul style="list-style-type: none"> INSTANCE SELECTIVITY WEIGHT

Table 159. Actions by hint type for the SET_PLAN_HINT stored procedure in CREATE mode (continued)

Hint type	Action	Required Input Parameters
Statement-level predicate selectivity overrides (continues)	<p>4. The staging table DSN8BQRY.DSN_PREDICATE_SELECTIVITY is populated with predicate selectivity overrides that are specified in the DeploymentParameters dictionary and PredicateSelectivityInstances array. The value of the ASSUMPTION column is set to 'OVERRIDE'.</p> <p>5. The following command is issued:</p> <pre> BIND QUERY EXPLAININPUTSCHEMA('DSN8BQRY') </pre>	

DELETE

Deletes an existing hint from the deployment table. The following table describes the specific actions and required input parameters for different types of hints:

Table 160. Actions by hint type for the SET_PLAN_HINT stored procedure in DELETE mode

Hint type	Action	Required Input Parameters
PLAN_TABLE access path hints	<p>The specified access path hint is deleted from the deployment PLAN_TABLE.</p> <ul style="list-style-type: none"> The access path hint to be deleted is identified by the parameters specified in the DeploymentParameters dictionary. The deployment PLAN_TABLE is <i>schema-name</i>.PLAN_TABLE, where <i>schema-name</i> is the PLAN_SCHEMA value that is specified in the DeploymentParameters dictionary. 	<ul style="list-style-type: none"> DeploymentParameters <ul style="list-style-type: none"> QUERYNO APPLNAME PROGNAME COLLID VERSION OPTHINT PLAN_SCHEMA (schema of the deployment PLAN_TABLE)
Statement-level access paths	<p>The FREE QUERY command is issued for the QUERYID value that is specified in the DeploymentParameters dictionary.</p>	<ul style="list-style-type: none"> DeploymentParameters <ul style="list-style-type: none"> QUERYID HINT_TYPE ('INSTANCE-LEVEL')
Statement-level optimization parameters “1” on page 976	<p>The FREE QUERY command is issued for the QUERYID value that is specified in the DeploymentParameters dictionary.</p>	<ul style="list-style-type: none"> DeploymentParameters <ul style="list-style-type: none"> QUERYID HINT_TYPE ('INSTANCE-LEVEL')

Table 160. Actions by hint type for the SET_PLAN_HINT stored procedure in DELETE mode (continued)

Hint type	Action	Required Input Parameters
Statement-level predicate selectivity overrides	<p>If optimization parameters are not in effect for the hint to be deleted, a FREE QUERY command is issued for the QUERYID value that is specified in the DeploymentParameters dictionary.</p> <p>Otherwise:</p> <ol style="list-style-type: none"> The staging table DSN8BQRY.DSN_USERQUERY_TABLE is populated with the optimization parameters to ensure that we do not lose the existing optimization parameters when FREE QUERY is performed subsequently. The FREE QUERY command is issued for the QUERYID value that is specified in the DeploymentParameters dictionary. The following command is issued to restore the optimization parameters: <pre> BIND QUERY EXPLAININPUTSCHEMA('DSN8BQRY') </pre>	<ul style="list-style-type: none"> DeploymentParameters <ul style="list-style-type: none"> HINT_TYPE ('INSTANCE-LEVEL') INSTANT_LEVEL_HINT_TYPE ('SELECTIVITY-OVERRIDE') QUERYID

MODIFY

Modifies an existing hint in the deployment table. The following table describes the specific actions and required input parameters for different types of hints:

Table 161. Actions by hint type for the SET_PLAN_HINT stored procedure in MODIFY mode

Hint type	Action	Required Input Parameters
PLAN_TABLE access path hints	<p>The information specified in the TableAccessRules and JoinSequenceRules dictionaries are applied to an existing access path in the deployment PLAN_TABLE.</p> <ul style="list-style-type: none"> The existing access path is identified by the parameters specified in the DeploymentParameters dictionary The deployment PLAN_TABLE is <i>schema-name</i>.PLAN_TABLE, where <i>schema-name</i> is the PLAN_SCHEMA value that is specified in the DeploymentParameters dictionary 	<ul style="list-style-type: none"> DeploymentParameters <ul style="list-style-type: none"> QUERYNO APPLNAME PROGNAME COLLID VERSION OPTHINT PLAN_SCHEMA (schema of the deployment PLAN_TABLE)

Table 161. Actions by hint type for the SET_PLAN_HINT stored procedure in MODIFY mode (continued)

Hint type	Action	Required Input Parameters
Statement-level access paths	<p>1. The following staging tables are populated based on an existing hint in the query catalog tables, and on the information that is specified in the DeploymentParameters, SQLStatement, TableAccessRules, and JoinSequenceRules dictionaries:</p> <ul style="list-style-type: none"> • DSN8BQRY.PLAN_TABLE • DSN8BQRY.DSN_USERQUERY_TABLE <p>The existing hint in the query catalog tables is identified by the QUERYID value that is specified in the DeploymentParameters dictionary.</p> <p>2. The following command is issued:</p> <pre> BIND QUERY EXPLAININPUTSCHEMA('DSN8BQRY') </pre>	<ul style="list-style-type: none"> • DeploymentParameters <ul style="list-style-type: none"> – QUERYID – If HINT_SCOPE=1 (package-level access path): <ul style="list-style-type: none"> - PROGNAME - COLLID - VERSION – HINT_TYPE ('INSTANCE-LEVEL') • SQLStatement <ul style="list-style-type: none"> – SQLText
Statement-level optimization parameters "1" on page 976	<p>1. The staging table DSN8BQRY.DSN_USERQUERY_TABLE is populated based on an existing hint in the query catalog tables and on the information specified in the DeploymentParameters, SQLStatement, and StatementLevelRules dictionaries.</p> <p>The existing hint in the query catalog tables is identified by the QUERYID value that is specified in the DeploymentParameters dictionary.</p> <p>2. The following command is issued:</p> <pre> BIND QUERY EXPLAININPUTSCHEMA('DSN8BQRY') </pre>	<ul style="list-style-type: none"> • DeploymentParameters <ul style="list-style-type: none"> – QUERYID – If HINT_SCOPE=1 (package-level access path hints): <ul style="list-style-type: none"> - PROGNAME - COLLID - VERSION – HINT_TYPE ('INSTANCE-LEVEL') – INSTANCE_LEVEL_HINT_TYPE ('OPTIMIZATION-PARAMETERS') • StatementLevelRules (any one of the following values) <ul style="list-style-type: none"> – REOPT – STARJOIN – MAX_PAR_DEGREE – DEGREE – SJTABLES • SQLStatement <ul style="list-style-type: none"> – SQLText

Table 161. Actions by hint type for the SET_PLAN_HINT stored procedure in MODIFY mode (continued)

Hint type	Action	Required Input Parameters
Statement-level predicate selectivity overrides	<ol style="list-style-type: none"> The following staging tables are populated based on an existing hint in the query catalog tables: <ul style="list-style-type: none"> DSN8QRY.DSN_USERQUERY_TABLE DSN8BQRY.DSN_PREDICAT_TABLE DSN8QRY.DSN_PREDICATE_SELECTIVITY <p>The existing hint in the catalog tables is identified by the QUERYID value that is specified in the DeploymentParameters dictionary.</p> If optimization parameters are in effect for the query, the staging table DSN8BQRY.DSN_USERQUERY_TABLE is further updated with the optimization parameters. The input tables are modified again based on the values that are specified in the PredicateSelectivityInstances array: <ul style="list-style-type: none"> If SELECTIVITY_ACTION is 'UPDATE' rows are added or modified as necessary. If SELECTIVITY_ACTION is 'DELETE' rows are deleted as necessary. The following command is issued: <pre> BIND QUERY EXPLAININPUTSCHEMA('DSN8BQRY') </pre> 	<ul style="list-style-type: none"> DeploymentParameters <ul style="list-style-type: none"> HINT_TYPE ('INSTANCE -LEVEL') INSTANCE_LEVEL_HINT_TYPE ('SELECTIVITY-OVERRIDE') QUERYID PredicateSelectivityInstances <ul style="list-style-type: none"> QBLOCKNO Predicates: <ul style="list-style-type: none"> PREDNO SelectivityInstances: <ul style="list-style-type: none"> INSTANCE SELECTIVITY (if SELECTIVITY_ACTION='UPDATE') WEIGHT (if SELECTIVITY_ACTION='UPDATE') SELECTIVITY_ACTION (optional, must be 'UPDATE' or 'DELETE' if specified.)

VALIDATE

Generates a hint and captures EXPLAIN information to validate the hint. The following table shows the actions taken and the required input parameters when VALIDATE mode is used.

Table 162. Actions by hint type for the SET_PLAN_HINT stored procedure in VALIDATE mode

Hint type	Action	Required Input Parameters
<ul style="list-style-type: none"> • PLAN_TABLE access path hints • Statement-level access paths • Statement-level optimization parameters 	<ol style="list-style-type: none"> 1. A check is completed to ensure that no existing rows the deployment PLAN_TABLE table match the following values that are specified in the DeploymentParameters and ExistingAccessPlanIdentifier dictionaries: <ul style="list-style-type: none"> • QUERYNO • APPLNAME • PROGNAME • COLLID • VERSION • OPTHINT • BIND_TIME 2. If the matching rows do not already exist, the access path identified by the information specified in the ExistingAccessPlanIdentifier dictionary is copied from the source PLAN_TABLE to the deployment PLAN_TABLE. The information specified in the DeploymentParameters, TableAccessRules and JoinSequenceRules dictionaries are applied to the copied plan. <ul style="list-style-type: none"> • The source PLAN_TABLE is <i>schema-name</i>.PLAN_TABLE, where <i>schema-name</i> is the PLAN_SCHEMA value that is specified in the ExistingAccessPlanIdentifier dictionary. • The deployment PLAN_TABLE is the <i>schema-name</i>.PLAN_TABLE, where <i>schema-name</i> is the value of the CURRENT SQLID special register for the process. 3. EXPLAIN information is captured for the resulting access path. The copied access path and the EXPLAIN output are kept or deleted based on the SQLCODE value that is returned for the EXPLAIN operation: <p>SQLCODE +000 The new PLAN_TABLE rows are deleted.</p> <p>SQLCODE +394 The new PLAN_TABLE rows are kept.</p> <p>SQLCODE +395 If the value of the HINT_USED column is blank for all rows, the new PLAN_TABLE rows are deleted.</p> 	<ul style="list-style-type: none"> • ExistingAccessPlanIdentifier <ul style="list-style-type: none"> – QUERYNO – APPLNAME – PROGNAME – COLLID – VERSION – PLAN_SCHEMA (the schema of the source PLAN_TABLE) • DeploymentParameters <ul style="list-style-type: none"> – OPTHINT

Table 162. Actions by hint type for the SET_PLAN_HINT stored procedure in VALIDATE mode (continued)

Hint type	Action	Required Input Parameters
Statement-level predicate selectivity overrides	<p>1. DSN8QRY.DSN_USER_QUERY_TABLE is populated with the information that is specified in the DeploymentParameters dictionary, and a check is completed to determine whether incompatible catalog table rows already exist.</p> <p>2. If incompatible catalog table rows are not found, the following input tables are populated with values from the DeploymentParameters and PredicateSelectivityInstances dictionaries, and the SYSIBM.SYSQUERYPRDICATE catalog table:</p> <ul style="list-style-type: none"> • DSN8QRY.DSN_USER_QUERY_TABLE • DSN8QRY.DSN_PREDICATE_SELECTIVITY • DSN8QRY.DSN_PREDICAT_TABLE <p>If compatible rows that have the same scope are found, the values of these rows are also copied to the input tables.</p> <p>3. The following BIND QUERY command is issued to create temporary rows in the catalog tables. “1” on page 975</p> <pre style="background-color: #f0f0f0; padding: 5px;"> BIND QUERY EXPLAININPUTSCHEMA('DSN8BQRY')</pre> <p>4. EXPLAIN information is captured for the resulting access path. The copied access path and the EXPLAIN output are kept or deleted based on the SQLCODE value that is returned for the EXPLAIN operation.</p> <p>If the SQLCODE +000 is returned by the explain operation, the value of the PLAN_TABLE.HINT_USED column is checked. If the value is 'SYSQUERYSEL n', the EXPLAIN records are kept.</p> <p>The generated EXPLAIN records are identified by the QUERYNO and EXPLAIN_TIME values that are specified by in the ExistingPredicateSelectivityIdentifier dictionary.</p> <p>5. A FREE QUERY command is issued to remove the selectivity overrides from the catalog tables.</p>	<ul style="list-style-type: none"> • DeploymentParameters: <ul style="list-style-type: none"> – HINT_TYPE ('INSTANCE_LEVEL') – INSTANCE_LEVEL_HINT_TYPE ('SELECTIVITY-OVERRIDE') – If HINT_SCOPE=1 (package-level): <ul style="list-style-type: none"> - PROGNAME - COLLID - VERSION • SQLStatement: <ul style="list-style-type: none"> – SQLText • PredicateSelectivityInstances: <ul style="list-style-type: none"> – QBLOCKNO – Predicates: <ul style="list-style-type: none"> - PREDNO – SelectivityInstances: <ul style="list-style-type: none"> • INSTANCE • SELECTIVITY (required only if SELECTIVITY_ACTION is 'UPDATE') • WEIGHT (required only if SELECTIVITY_ACTION is 'UPDATE') • ExistingPredicateSelectivityIdentifier <ul style="list-style-type: none"> – QUERYNO – EXPLAIN_TIME – PLAN_SCHEMA

Notes:

1. In VALIDATE processing for static statements and dynamic statements that are bound with the DYNAMICRULES(BIND) option, the COLLID, PROGNAME, and VERSION values for the package that contains the SET_PLAN_HINT stored procedure are used for the BIND QUERY operation. Therefore, the SQL processing options of DSNADM.DSNADMHS

are used. Differences between the SQL processing options of the specified package and DSNADMHS might cause the BIND QUERY command to fail. When that happens, the validate operation fails. Option differences that might cause such failures include decimal point representation and others. For more information, see:

[“Options affecting SQL” on page 320](#)

[“Decimal point representation” on page 323](#)

Notes:

1. If the SET_PLAN_HINT stored procedure is called to create, modify, or delete statement-level optimization parameters (HINT_TYPE=INSTANCE-LEVEL and INSTANCE_LEVEL_HINT_TYPE=OPTIMIZATION-PARAMETERS), any existing predicate selectivity overrides for the same statement are removed.

HINT_TYPE

The type of access path hint:

TRADITIONAL

PLAN_TABLE access path hints. This value is used by default.

INSTANCE-LEVEL

Statement-level hints, including:

- Access paths.
- Optimization parameters.
- Predicate selectivity overrides.

HINT_SCOPE

The scope of the statement-level hint:

SYSTEM-LEVEL

The hint applies at the system level. This value is used by default.

PACKAGE-LEVEL

The hint applies at the package level.

INSTANCE_LEVEL_HINT_TYPE

The action specified by statement-level rows:

ACCESS-PATH

Statement-level access paths. This value is used by default.

OPTIMIZATION-PARAMETERS

Statement-level optimization parameters.

SELECTIVITY-OVERRIDE

Statement-level predicate selectivity overrides.

Keys that correspond to the following PLAN_TABLE columns:

- **OPTHINT**
- **PROGNAME** [“1” on page 975](#)
- **APPLNAME**
- **VERSION** [“1” on page 975](#)
- **COLLID** [“1” on page 975](#)
- **QUERYNO**
- **BIND_TIME**
- **QUERYID**

For the meanings and accepted values for these keys, see: [PLAN_TABLE \(Db2 Performance\)](#).

PLAN_SCHEMA

The schema of the deployment PLAN_TABLE.

The following example shows the format of the DeploymentParameters dictionary for a PLAN_TABLE access path hint:

```
<key>DeploymentParameters</key>
<dict>
  <key>MODE</key>
  <string>CREATE</string>
  <key>HINT_TYPE</key>
  <string>TRADITIONAL</string>
  <key>HINT_SCOPE</key>
  <string>PACKAGE-LEVEL</string>
  <key>APPLNAME</key>
  <string></string>
  <key>PROGNAME</key>
  <string>DSNTIAD</string>
  <key>COLLID</key>
  <string>DSNTIAB1</string>
  <key>VERSION</key>
  <string>*</string>
  <key>QUERYNO</key>
  <string>200</string>
  <key>PLAN_SCHEMA</key>
  <string>ADMF002</string>
  <key>OPTHINT</key>
  <string>HINT001</string>
</dict>
```

The following example shows the format of the DeploymentParameters dictionary for a statement-level predicate selectivity override:

```
<key>DeploymentParameters</key>
<dict>
  <key>MODE</key>
  <string>CREATE</string>
  <key>HINT_TYPE</key>
  <string>INSTANCE-LEVEL</string>
  <key>INSTANCE_LEVEL_HINT_TYPE</key>
  <string>SELECTIVITY-OVERRIDE</string>
  <key>HINT_SCOPE</key>
  <string>PACKAGE-LEVEL</string>
  <key>PROGNAME</key>
  <string>DSNTIAD</string>
  <key>COLLID</key>
  <string>DSNTIAB1</string>
  <key>VERSION</key>
  <string></string>
</dict>
```

StatementList

A list of SQL statements and the hint definition that is associated with each. Only one SQL statement is supported. Additional SQL statements are ignored. The following example shows the format of the StatementList array:

```
<key>StatementList</key>
<array>
  <dict>
    <key>DeploymentParameters</key>
    <dict>
    </dict>
    <key>SQLStatement</key>
    <dict>
    </dict>
    <key>ExistingAccessPlanIdentifier</key>
    <dict>
    </dict>
    <key>StatementLevelRules</key>
    <dict>
    </dict>
    <key>PlanLevelRules</key>
    <dict>
      <key>TableAccessRules</key>
      <array></array>
      <key>JoinSequenceRules</key>
      <array></array>
    </dict>
  </dict>
</array>
<key>PredicateSelectivityInstances</key>
```

```

<array>
</array>
<key>ExistingPredicateSelectivityIdentifier</key>
<dict>
</dict>
</dict>
</array>

```

DeploymentParameters

Deployment parameters can be specified globally, or specified at the statement level. Statement-level deployment parameters override the global parameters for a particular statement. For a description of the DeploymentParameter dictionary, see [“DeploymentParameters” on page 965](#).

SQLStatement

The statement text and the default schema for resolving unqualified table names in the statement.

The SQLStatement dictionary can contain the following keys:

SQLText

The text of the SQL statement.

SCHEMA

The default schema for resolving unqualified table names in the statement.

The following example shows the format of the SQLStatement dictionary:

```

<key>SQLStatement</key>
<dict>
  <key>SCHEMA</key>
  <string>USER001</string>
  <key>SQLText</key>
  <string>
    SELECT s_name,
    count(*) as numwait
    FROM supplier,
    lineitem l1,
    order,
    nation
    WHERE s_suppkey = l1.l_suppkey
    AND o_orderkey = l1.l_orderkey
    AND o_orderstatus = 'F'
    AND l1.l_receiptdate > l1.l_commitdate
    AND EXISTS(
    SELECT *
    FROM lineitem l2
    WHERE l2.l_orderkey = l1.l_orderkey
    AND l2.l_suppkey <> l1.l_suppkey
    )
    AND NOT EXISTS (
    SELECT *
    FROM lineitem l3
    WHERE l3.l_orderkey = l1.l_orderkey
    AND l3.l_suppkey <> l1.l_suppkey
    AND l3.l_receiptdate > l3.l_commitdate
    )
    AND s_nationkey = n_nationkey
    AND n_name = 'USA'
    GROUP BY s_name
    ORDER BY numwait desc,s_name
  </string>
</dict>

```

ExistingAccessPlanIdentifier

A list of parameters that identify an access path in a PLAN_TABLE. ExistingAccessPlanIdentifier applies only for hints that specify access paths.

The ExistingAccessPlanIdentifier dictionary can contain the following keys:

Keys that correspond to the following PLAN_TABLE columns

- OPTHINT
- PROGNAME

- **APPLNAME**
- **VERSION**
- **COLLID**
- **QUERYNO**
- **BIND_TIME**

For the meanings and accepted values for these keys, see: [PLAN_TABLE \(Db2 Performance\)](#).

PLAN_SCHEMA

The schema of the PLAN_TABLE that contains the original access path.

The following example shows the format of the ExistingAccessPlanIdentifier dictionary:

```
<key>ExistingAccessPlanIdentifier</key>
<dict>
  <key>APPLNAME</key>
  <string></string>
  <key>PROGNAME</key>
  <string>DSNADMXX</string>
  <key>COLLID</key>
  <string>DSNADM</string>
  <key>VERSION</key>
  <string>*</string>
  <key>QUERYNO</key>
  <string>200</string>
  <key>PLAN_SCHEMA</key>
  <string>ADMFO02</string>
  <key>OPTHINT</key>
  <string>HINT001</string>
  <key>BIND_TIME</key>
  <string>2012-11-05-07.10.41.700000</string>
</dict>
```

StatementLevelRules

A list of parameters that identify optimization parameter hint properties. StatementLevelRules applies only to hints for optimization parameters.

The StatementLevelRules dictionary can contain the following keys:

Keys that correspond to the following DSN_USERQUERY_TABLE columns:

- **REOPT**
- **STARJOIN**
- **MAX_PAR_DEGREE**
- **DEGREE** (for the DEF_CURR_DEGREE column)
- **SJTABLES**

For meanings and accepted values for these keys, see the column descriptions in [DSN_USERQUERY_TABLE \(Db2 Performance\)](#).

The following example shows the format of the StatementLevelRules dictionary:

```
<key>StatementLevelRules</key>
<dict>
  <key>REOPT</key>
  <dict>
    <key>VALUE</key>
    <string>1</string>
  </dict>
  <key>STARJOIN</key>
  <dict>
    <key>VALUE</key>
    <string>N</string>
  </dict>
  <key>MAX_PAR_DEGREE</key>
  <dict>
    <key>VALUE</key>
    <string>2</string>
  </dict>
</dict>
```

```

    <key>DEGREE</key>
  <dict>
    <key>VALUE</key>
    <string>ONE</string>
  </dict>
  <key>SJTABLES</key>
  <dict>
    <key>VALUE</key>
    <string>2</string>
  </dict>
</dict>

```

PlanLevelRules

A list of parameters that describe the customized access path that is specified by the hint, including separate arrays for table access and join sequence information. PlanLevelRules applies only to hints that specify access paths. The following example shows the format of this PlanLevelRules dictionary:

```

<key>PlanLevelRules</key>
<dict>
  <key>TableAccessRules</key>
  <array></array>
  <key>JoinSequenceRules</key>
  <array></array>
</dict>

```

TableAccessRules

A list of rules that are related to table access and that describe data access methods, such as table space scans and index scans, for example.

Each table access rule is represented by a TableReferenceIdentifier and its corresponding Settings.

TableReferenceIdentifier

A list of properties that identify the table reference. The properties correspond to PLAN_TABLE columns:

- **QBLOCKNO**
- **TABNO**
- **TABLE_CREATOR** (for the CREATOR column)
- **TABLE_NAME** (for the TNAME column)
- **CORRELATION_NAME**

For the meanings and accepted values for these properties, see: [PLAN_TABLE \(Db2 Performance\)](#).

Settings

A list of access properties. The properties correspond to PLAN_TABLE columns:

- **ACCESS_TYPE** (for the ACCESSTYPE column)
- **ACCESS_CREATOR** (for the ACCESCREATOR column)
- **ACCESS_NAME** (for the ACCESSNAME column)
- **PREFETCH**
- **PAGE_RANGE**
- **SORTN_JOIN**
- **SORTC_JOIN**
- **PARALLELISM_MODE**
- **ACCESS_DEGREE**
- **JOIN_DEGREE**
- **ACCESS_PGROUP_ID**
- **JOIN_PGROUP_ID**

- **PRIMARY_ACESSTYPE**
- **METHOD**

For the meanings and accepted values for these properties, see: [PLAN_TABLE \(Db2 Performance\)](#).

The following example shows the format of this TableAccessRules array:

```
<key>TableAccessRules</key>
<array>
  <dict>
    <key>TableReferenceIdentifier</key>
    <array>
      <dict>
        <key>NAME</key>
        <string>QBLOCKNO</string>
        <key>VALUE</key>
        <string>1</string>
      </dict>
      ...
    </array>
    <key>Settings</key>
    <array>
      <dict>
        <key>NAME</key>
        <string>ACCESS_TYPE</string>
        <key>VALUE</key>
        <string>IXSCAN</string>
      </dict>
    </array>
  </dict>
</array>
```

JoinSequenceRules

A list of join sequence customization rules. Each join sequence rule is represented by the Settings and Roots (root nodes) for the join sequence. The join sequence rules correspond to the join sequence and join methods, such as merge join and hybrid join, for example.

Settings

A property for the join sequence rule that correspond to the PLAN_TABLE column of the same name: **QBLOCKNO**

Roots

A list of root nodes in the join sequence, where each root node is identified by the node type. Depending on the node type, a TABLE_REFERENCE_NODE holds the properties to identify the table reference, while an OPERATOR_NODE holds the properties of the operator.

TYPE

The node type:

- TABLE_REFERENCE_NODE
- OPERATOR NODE

TableReferenceIdentifier

A list of properties to identify the table reference if node type is TABLE_REFERENCE_NODE. These properties correspond to PLAN_TABLE columns:

- **QBLOCKNO**
- **TABNO**
- **TABLE_CREATOR** (for the CREATOR column)
- **TABLE_NAME** (for the TNAME column)
- **CORRELATION_NAME**

For the meanings and accepted values for these properties, see: [PLAN_TABLE \(Db2 Performance\)](#).

Settings

A list of properties of this operator if node type is OPERATOR_NODE. These properties correspond to PLAN_TABLE columns:

- **JOIN_METHOD** (for the METHOD column)
- **SORTN_JOIN**
- **SORTC_JOIN**
- **JOIN_DEGREE**
- **JOIN_PGROUP_ID**

For the meanings and accepted values for these properties, see: [PLAN_TABLE \(Db2 Performance\)](#).

Left

A description of a left-side child node. The data structure is similar to the root node.

Right

A description of a right-side child node. The data structure is similar to the root node.

The following example shows the format of this JoinSequence array:

```
<key>JoinSequenceRules</key>
<array>
  <dict>
    <key>Settings</key>
    <array>
      <dict>
        <key>NAME</key>
        <string>QBLOCKNO</string>
        <key>VALUE</key>
        <string>1</string>
      </dict>
    </array>
    <key>Roots</key>
    <array>
      <dict>
        <key>TYPE</key>
        <string>OPERATOR_NODE</string>
        <key>Settings</key>
        <array>
          <dict>
            <key>NAME</key>
            <string>JOIN_METHOD</string>
            <key>VALUE</key>
            <string>NLJOIN</string>
          </dict>
        </array>
        <key>Left</key>
        <dict>
          <key>TYPE</key>
          <string>OPERATOR_NODE</string>
          <key>Settings</key>
          <array>
            <dict>
              <key>NAME</key>
              <string>JOIN_METHOD</string>
              <key>VALUE</key>
              <string>SMJOIN</string>
            </dict>
          </array>
          <key>Left</key>
          <dict>
            <key>TYPE</key>
            <string>OPERATOR_NODE</string>
            <key>Settings</key>
            <array>
              <dict>
                <key>NAME</key>
                <string>JOIN_METHOD</string>
                <key>VALUE</key>
                <string>NLJOIN</string>
              </dict>
            </array>
          </dict>
        </dict>
      </dict>
    </array>
  </dict>
</array>
```

```

</array>
<key>Left</key>
<dict>
  <key>TYPE</key>
  <string>TABLE_REFERENCE_NODE</string>
  <key>TableReferenceIdentifier</key>
  <array>
    <dict>
      <key>NAME</key>
      <string>TABLE_NAME</string>
      <key>VALUE</key>
      <string>NATION</string>
    </dict>
  </array>
</dict>
<key>Right</key>
<dict>
  <key>TYPE</key>
  <string>TABLE_REFERENCE_NODE</string>
  <key>TableReferenceIdentifier</key>
  <array>
    <dict>
      <key>NAME</key>
      <string>TABLE_NAME</string>
      <key>VALUE</key>
      <string>SUPPLIER</string>
    </dict>
  </array>
</dict>
<key>Right</key>
<dict>
  <key>TYPE</key>
  <string>TABLE_REFERENCE_NODE</string>
  <key>TableReferenceIdentifier</key>
  <array>
    <dict>
      <key>NAME</key>
      <string>TABLE_NAME</string>
      <key>VALUE</key>
      <string>LINEITEM</string>
    </dict>
  </array>
</dict>
<key>Right</key>
<dict>
  <key>TYPE</key>
  <string>TABLE_REFERENCE_NODE</string>
  <key>TableReferenceIdentifier</key>
  <array>
    <dict>
      <key>NAME</key>
      <string>TABLE_NAME</string>
      <key>VALUE</key>
      <string>ORDER</string>
    </dict>
  </array>
</dict>
</array>
</dict>
</array>
</dict>
</array>
</dict>
</array>

```

PredicateSelectivityInstances

A list of predicates and their selectivity instances. PredicateSelectivityInstances applies only to hints that specify selectivity overrides.

QBLOCKNO

The identifier of the query block that contains the predicate.

Predicates

SELECTIVITY_ACTION

The processing mode for the selectivity instance. One of the following values:

- **UPDATE** (valid when MODE is CREATE, MODIFY, or VALIDATE.) This is the default value.

- **DELETE** (valid when MODE is MODIFY, or VALIDATE for an existing hint.)

INSTANCE

The identifier of the selectivity instance. A positive integer greater than or equal to 1.

SELECTIVITY

Percentage of rows in the table that satisfy the predicate as a value 0–1. This value is mandatory when SELECTIVITY_ACTION='UPDATE'.

WEIGHT

Percentage of executions in which the selectivity instance applies, as a value 0–1. This value is mandatory when SELECTIVITY_ACTION='UPDATE'.

The following example shows the format of the PredicateSelectivityInstances array:

```
<key>PredicateSelectivityInstances</key>
<array>
  <dict>
    <key>QBLOCKNO</key><string>1</string>
    <key>Predicates</key>
    <array>
      <dict>
        <key>PREDNO</key><string>2</string>
        <key>SelectivityInstances</key>
        <array>
          <dict>
            <key>SELECTIVITY_ACTION</key><string>UPDATE</string>
            <key>INSTANCE</key><string>1</string>
            <key>SELECTIVITY</key><string>0.1111</string>
            <key>WEIGHT</key><string>0.11111</string>
          </dict>
          <dict>
            <key>INSTANCE</key><string>2</string>
            <key>SELECTIVITY</key><string>0.1222</string>
            <key>WEIGHT</key><string>0.12222</string>
          </dict>
        </array>
      </dict>
    </array>
  </dict>
  <dict>
    <key>PREDNO</key><string>3</string>
    <key>SelectivityInstances</key>
    <array>
      <dict>
        <key>INSTANCE</key><string>3</string>
        <key>SELECTIVITY</key><string>0.1333</string>
        <key>WEIGHT</key><string>0.13333</string>
      </dict>
      <dict>
        <key>INSTANCE</key><string>4</string>
        <key>SELECTIVITY</key><string>0.1444</string>
        <key>WEIGHT</key><string>0.14444</string>
      </dict>
    </array>
  </dict>
</array>
</dict>
</array>
</dict>
</array>
```

ExistingPredicateSelectivityIdentifier

Identifies the EXPLAIN tables rows that are copied to input tables for the BIND QUERY operation. ExistingPredicateSelectivityIdentifier applies only to hints that override selectivities.

PLAN_SCHEMA

The schema of the following EXPLAIN tables: PLAN_TABLE, DSN_PREDICAT_TABLE, and DSN_PREDICATE_SELECTIVITY tables.

EXPLAIN_TIME

The time that the row was inserted by EXPLAIN.

QUERYNO

The identifier of the statement.

The following example shows the format of the ExistingPredicateSelectivityIdentifier dictionary:

```
<key>ExistingPredicateSelectivityIdentifier</key>
<dict>
  <key>QUERYNO</key><string>100</string>
  <key>EXPLAIN_TIME</key><string>2013-03-20-14.29.55.660000</string>
  <key>PLAN_SCHEMA</key><string>ADMF001</string>
</dict>
```

xml_filter

An input parameter of type BLOB(4K). Specifies a valid XPath query string to retrieve a single value from an XML output document.

xml_output

An output parameter of type BLOB(2G)

When the mode is VALIDATE for hints other than selectivity overrides, *xml_output* has the following format:

```
<?xml version="1.0" encoding="UTF-8"?>
<plist version="1.0">
<dict>
  <key>Document Type Name</key><string>Data Server Hint Management Output</string>
  <key>Document Type Major Version</key><integer>1</integer>
  <key>Document Type Minor Version</key><integer>0</integer>
  <key>Data Server Product Name</key><string>DSN</string>
  <key>Data Server Product Version</key><string>10.1.5</string>
  <key>Data Server Major Version</key><integer>10</integer>
  <key>Data Server Minor Version</key><integer>1</integer>
  <key>Data Server Platform</key><string>z/OS</string>
  <key>Document Locale</key><string>en_US</string>
  <key>Hint Validation</key>
</dict>
  <key>Display Name</key><string>Hint Validation</string>
  <key>EXPLAIN SQLCODE</key>
</dict>
  <key>Display Name</key><string>EXPLAIN SQLCODE</string>
  <key>Value</key><string>394</string>
  <key>Hint</key><string/>
</dict>
  <key>Additional EXPLAIN Information</key>
</dict>
  <key>Display Name</key><string>Additional EXPLAIN Information</string>
  <key>Value</key>
  <string>DSNT404I SQLCODE = 394, WARNING: USER SPECIFIED OPTIMIZATION HINTS USED
DURING ACCESS PATH SELECTION DSNT418I SQLSTATE = 01629 SQLSTATE RETURN CODE
DSNT415I SQLERRP = DSNXOPCO SQL PROCEDURE DETECTING ERROR DSNT416I SQLERRD =
20 0 25 1264473616 0 0 SQL DIAGNOSTIC INFORMATION DSNT416I SQLERRD = X'00000014'
X'00000000' X'00000019' X'4B5E5610' X'00000000' X'00000000' SQL DIAGNOSTIC
INFORMATION</string>
  <key>Hint</key><string/>
</dict>
  <key>Hint</key><string></string>
</dict>
</dict>
</plist>
```

When the mode is CREATE, MODIFY, or DELETE for PLAN_TABLE access path hints, *xml_output* has the following format:

```
<?xml version="1.0" encoding="UTF-8"?>
<plist version="1.0">
<dict>
  <key>Document Type Name</key><string>Data Server Hint Management Output</string>
  <key>Document Type Major Version</key><integer>1</integer>
  <key>Document Type Minor Version</key><integer>0</integer>
  <key>Data Server Product Name</key><string>DSN</string>
  <key>Data Server Product Version</key><string>10.1.5</string>
  <key>Data Server Major Version</key><integer>10</integer>
  <key>Data Server Minor Version</key><integer>1</integer>
  <key>Data Server Platform</key><string>z/OS</string>
  <key>Document Locale</key><string>en_US</string>
  <key>Hint Deployment</key>
</dict>
  <key>Display Name</key><string>Hint Deployment</string>
```

```

    <key>SQLCODE</key>
  </dict>
  <key>Display Name</key><string>SQLCODE</string>
  <key>Value</key><string>0</string>
  <key>Hint</key><string/>
</dict>
<key>Hint</key><string></string>
</dict>
</dict>
</plist>

```

When the mode is CREATE or MODIFY for statement-level hints, *xml_output* has the following format:

```

<?xml version="1.0" encoding="UTF-8"?>
<plist version="1.0">
<dict>
  <key>Document Type Name</key><string>Data Server Hint Management Output</string>
  <key>Document Type Major Version</key><integer>1</integer>
  <key>Document Type Minor Version</key><integer>0</integer>
  <key>Data Server Product Name</key><string>DSN</string>
  <key>Data Server Product Version</key><string>10.1.5</string>
  <key>Data Server Major Version</key><integer>10</integer>
  <key>Data Server Minor Version</key><integer>1</integer>
  <key>Data Server Platform</key><string>z/OS</string>
  <key>Document Locale</key><string>en_US</string>
  <key>Hint Deployment</key>
</dict>
  <key>Display Name</key><string>Hint Deployment</string>
  <key>BIND QUERY Message</key>
</dict>
  <key>Display Name</key><string>BIND QUERY Message</string>
  <key>Value</key>
  <string>DSNT280I @ BIND QUERY FOR QUERYNO = 8888 SUCCESSFUL DSNT289I @ BIND QUERY
COMMAND INVOKED BY THE DSNE PROCESSOR. UNDER THIS ENVIRONMENT, THE COMMAND
CAN ONLY PROCESS THE FIRST APPLICABLE QUERY. ALL OTHER QUERIES ARE NOT PROCESSED.
</string>
  <key>Hint</key><string/>
</dict>
  <key>QUERYID</key>
</dict>
  <key>Display Name</key><string>QUERYID</string>
  <key>Value</key>
  <string>999</string>
  <key>Hint</key><string/>
</dict>
  <key>Hint</key><string></string>
</dict>
</dict>
</plist>

```

When the mode is DELETE for statement-level hints, *xml_output* has the following format. The format is different for statement-level selectivity overrides when preexisting optimization parameters are specified.

```

<?xml version="1.0" encoding="UTF-8"?>
<plist version="1.0">
<dict>
  <key>Document Type Name</key><string>Data Server Hint Management Output</string>
  <key>Document Type Major Version</key><integer>1</integer>
  <key>Document Type Minor Version</key><integer>0</integer>
  <key>Data Server Product Name</key><string>DSN</string>
  <key>Data Server Product Version</key><string>10.1.5</string>
  <key>Data Server Major Version</key><integer>10</integer>
  <key>Data Server Minor Version</key><integer>1</integer>
  <key>Data Server Platform</key><string>z/OS</string>
  <key>Document Locale</key><string>en_US</string>
  <key>Hint Deployment</key>
</dict>
  <key>Display Name</key><string>Hint Deployment</string>
  <key>FREE QUERY Message</key>
</dict>
  <key>Display Name</key><string>FREE QUERY Message</string>
  <key>Value</key>
  <string>DSNT280I @ FREE QUERY FOR QUERYID = 6 SUCCESSFUL DSNT290I @ FREE QUERY
COMMAND COMPLETED</string>
  <key>Hint</key><string/>
</dict>
  <key>Hint</key><string/>
</dict>
</plist>

```

```
</dict>
</plist>
```

When the mode is DELETE for statement-level predicate selectivity overrides and preexisting optimization parameters are specified, *xml_output* has the following format:

```
<?xml version="1.0" encoding="UTF-8"?>
<plist version="1.0">
<dict>
  <key>Document Type Name</key><string>Data Server Hint Management Output</string>
  <key>Document Type Major Version</key><integer>1</integer>
  <key>Document Type Minor Version</key><integer>0</integer>
  <key>Data Server Product Name</key><string>DSN</string>
  <key>Data Server Product Version</key><string>11.1.5</string>
  <key>Data Server Major Version</key><integer>11</integer>
  <key>Data Server Minor Version</key><integer>1</integer>
  <key>Data Server Platform</key><string>z/OS</string>
  <key>Document Locale</key><string>en_US</string>
  <key>Hint Deployment</key>
  <dict>
    <key>Display Name</key><string>Hint Deployment</string>
    <key>FREE QUERY Message</key>
    <dict>
      <key>Display Name</key><string>FREE QUERY Message</string>
      <key>Value</key>
      <string>DSNT280I @ FREE QUERY FOR QUERYID = n SUCCESSFUL DSNT290I @ FREE QUERY
      COMMAND COMPLETED</string>
      <key>Hint</key><string/>
    </dict>
    <key>BIND QUERY</key>
    <dict>
      <key>Display Name</key><string>BIND QUERY</string>
      <key>Message</key>
      <dict>
        <key>Display Name</key><string>Message</string>
        <key>Value</key>
        <string>DSNT280I @ BIND QUERY FOR QUERYNO = n SUCCESSFUL DSNT289I @ BIND QUERY
        COMMAND INVOKED BY THE DSNE PROCESSOR. UNDER THIS ENVIRONMENT, THE COMMAND
        CAN ONLY PROCESS THE FIRST APPLICABLE QUERY. ALL OTHER QUERIES ARE NOT PROCESSED.
        </string>
        <key>Hint</key><string/>
      </dict>
      <key>QUERYID</key>
      <dict>
        <key>Display Name</key><string>QUERYID</string>
        <key>Value</key><string>n</string>
        <key>Hint</key><string/>
      </dict>
      <key>Hint</key><string/>
    </dict>
  </dict>
</plist>
```

xml_message

An output parameter of type BLOB(2G). The output is an XML document with the following format:

```
<?xml version="1.0" encoding="UTF-8"?>
<plist version="1.0">
<dict>
  <key>Document Type Name</key>
  <string>Data Server Message</string>
  <key>Document Type Major Version</key><integer>1</integer>
  <key>Document Type Minor Version</key><integer>0</integer>
  <key>Data Server Product Name</key><string>DSN</string>
  <key>Data Server Product Version</key><string>10.1.5</string>
  <key>Data Server Major Version</key><integer>10</integer>
  <key>Data Server Minor Version</key><integer>1</integer>
  <key>Data Server Platform</key><string>z/OS</string>
  <key>Document Locale</key><string>en_US</string>
  <key>Short Message Text</key>
  <dict>
    <key>Display Name</key><string>Short Message Text</string>
    <key>Value</key>
    <string>DSNA618I DSNADMHS SQL ERROR DURING SQL STATEMENT
    CALL, PROCEDURE=SYSPROC.ADMIN_COMMAND_DSN DSNT408I SQLCODE
    = -471, ERROR: INVOCATION OF FUNCTION OR PROCEDURE
    SYSPROC.ADMIN_COMMAND_DSN FAILED DUE TO REASON 00E79001
  </dict>
</dict>
```

```
DSNT418I SQLSTATE = 55023 SQLSTATE RETURN CODE DSNT415I
SQLERRP = DSNX9GPL SQL PROCEDURE DETECTING ERROR DSNT416I
SQLERRD = -30 0 0 -1 0 0 SQL DIAGNOSTIC INFORMATION DSNT416I
SQLERRD = X'FFFFFFFFE2' X'00000000' X'00000000' X'FFFFFFFF'
X'00000000' X'00000000' SQL DIAGNOSTIC INFORMATION</string>
<key>Hint</key><string></string>
</dict>
</dict>
</plist>
```

◀ PSPI

Related concepts

[Common SQL API stored procedures \(Db2 Administration Guide\)](#)

Related tasks

[Influencing access path selection \(Db2 Performance\)](#)

[Creating input EXPLAIN tables under a separate schema \(Db2 Performance\)](#)

Related reference

[Tables for influencing access path selection \(Db2 Performance\)](#)

[BIND QUERY subcommand \(DSN\) \(Db2 Commands\)](#)

[FREE QUERY subcommand \(DSN\) \(Db2 Commands\)](#)

SQLJ.ALTER_JAVA_PATH stored procedure

SQLJ.ALTER_JAVA_PATH modifies the class resolution path of an installed JAR.

SQLJ.ALTER_JAVA_PATH specifies the class resolution path that the JVM uses when a JAR file that is part of a Java stored procedure references a class that is neither contained in that JAR file, found in the CLASSPATH, nor system-supplied.

SQLJ.ALTER_JAVA_PATH authorization

Privilege set: If the CALL statement is embedded in an application program, the privilege set consists of the privileges that are held by the owner of the plan or package. If the statement is dynamically prepared, the privilege set consists of the privileges that are held by the authorization IDs of the process.

For calling SQLJ.ALTER_JAVA_PATH, the privilege set must include at least one of the following items:

- EXECUTE privilege on SQLJ.ALTER_JAVA_PATH
- Ownership of SQLJ.ALTER_JAVA_PATH
- SYSADM authority

The privilege set must also include the authority to alter a JAR, which consists of at least one of the following items:

- Ownership of the JAR
- ALTERIN privilege on the schema of the JAR

The authorization ID that matches the schema name implicitly has the ALTERIN privilege on the schema.

- SYSADM or SYSCTRL authority

For referring to JAR *jar2* in the Java path, the privilege set must include at least one of the following items:

- Ownership of *jar2*
- USAGE privilege on *jar2*
- SYSADM authority

SQLJ.ALTER_JAVA_PATH syntax

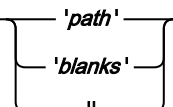
►► CALL SQLJ.ALTER_JAVA_PATH ((JAR-name1 , ) ►►

path:

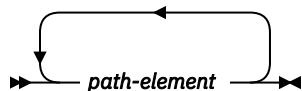

path-element:

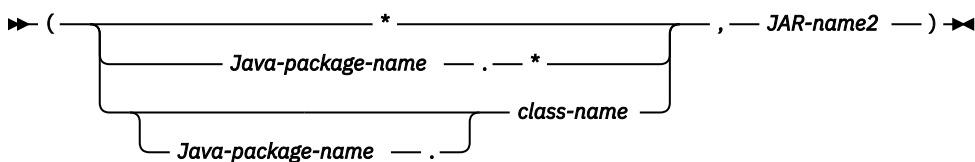
►► (

Java-package-name:

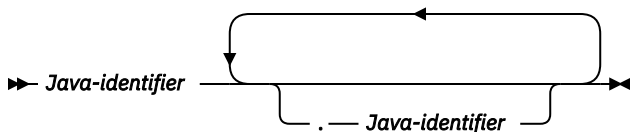
►► 

class-name:

►► Java-identifier ►►

SQLJ.ALTER_JAVA_PATH parameters

JAR-name1

A VARCHAR(257) input parameter that contains the Db2 name of the JAR whose path is to be altered, in the form *schema.JAR-id* or *JAR-id*. *JAR-name1* is the name that you use when you refer to the JAR in SQL statements. If you omit *schema*, Db2 uses the SQL authorization ID that is in the CURRENT SCHEMA special register.

path

A VARCHAR(2048) input parameter that specifies the class resolution path that the JVM uses when *JAR-name1* references a class that is neither contained in *JAR-name1*, found in the CLASSPATH, nor system-supplied.

During execution of the Java routine, when Db2 encounters an unresolved class reference, Db2 compares each path element in the path to the class reference. If a path element matches the class reference, Db2 searches for the class in the JAR that is specified by the path element.

*

Indicates that any class reference can be searched for in the JAR that is identified by *JAR-name2*. If an error prevents the class from being found, the search terminates, and a `java.lang.ClassNotFoundException` is thrown to report that error. If the class is not found in the JAR, the search continues with the next path element.

Java-package-name.*

Indicates that class references for classes that are in the package named *Java-package-name* are searched for in the JAR that is identified by *JAR-name2*. If an error prevents a class from being found, the search terminates, and a `java.lang.ClassNotFoundException` is

thrown to report that error. If a class is not found in the JAR, the search terminates, and a `java.lang.NoClassDefFoundError` is thrown.

If the class reference is to a class in a different package, the search continues with the next path element.

Java-package-name.class-name or class-name

Indicates that class references for classes whose fully qualified name matches *Java-package-name.class-name* or *class-name* are searched for in the JAR that is identified by *JAR-name2*. Class references for classes that are in packages within the package named *Java-package-name* are not searched for in the JAR that is identified by *JAR-name2*. If an error prevents a class from being found, the search terminates, and a `java.lang.ClassNotFoundException` is thrown to report that error. If a class is not found in the JAR, the search terminates and a `java.lang.NoClassDefFoundError` is thrown.

If the class reference is to a different class, the search continues with the next path element.

JAR-name2

Specifies the Db2 name of the JAR that is to be searched. The form of *JAR-name2* is *schema.JAR-id* or *JAR-id*. If *schema* is omitted, the JAR name is implicitly qualified with the schema name in the CURRENT SCHEMA special register. JAR *JAR-name2* must exist at the current server. *JAR-name2* must not be the same as *JAR-name1*.

SQLJ.ALTER_JAVA_PATH usage notes

Stored procedures that reference classes in multiple JAR files: A stored procedure that is packaged as a JAR file might reference classes that are in other JAR files, and the referenced JAR files might reference classes in still other JAR files. You need to specify class resolution paths for *all* dependencies among JAR files that the stored procedure uses. For any JAR files that the stored procedure uses that cannot be found in the CLASSPATH, and are not system-supplied, you need to use SQLJ.ALTER_JAVA_PATH to define the class resolution path. For example, suppose that stored procedure SP, which is packaged in JAR file JARSP, references classes in JAR files JAR1 and JAR2. Classes in JAR file JAR1 reference classes that are in JAR file JAR2. None of the JAR files are in the CLASSPATH or are system-supplied. You need to call SQLJ.ALTER_JAVA_PATH twice, to define the following class resolution paths:

- From JARSP to JAR1 and JAR2
- From JAR1 to JAR2

SQLJ.ALTER_JAVA_PATH example

Suppose that the JAR file that is named DB2INST3.BUILDPLAN references classes that are in a previously installed JAR that is named DB2INST3.BUILDPLAN2. Those classes are in Java package buildPlan2. The following Java program calls SQLJ.ALTER_JAVA_PATH to add the classes in the buildPlan2 package to the resolution path for DB2INST3.BUILDPLAN.

```
import java.sql.*; // JDBC classes
import java.io.IOException;
import java.io.File;
import java.io.FileInputStream;
class SimpleInstallJar
{
    public static void main (String argv[])
    {
        String url = "jdbc:db2://sysmvs1.st1.ibm.com:5021";
        String jarname = "DB2INST3.BUILDPLAN";
        String resolutionPath =
            "(buildPlan2.*,DB2INST3.BUILDPLAN2)";
        try
        {
            Class.forName ("com.ibm.db2.jcc.DB2Driver").newInstance ();
            Connection con =
                DriverManager.getConnection(url, "MYID", "MYPW");
            CallableStatement stmt;
            String sql = "Call SQLJ.ALTER_JAVA_PATH(?, ?)";
            stmt = con.prepareCall(sql);
            stmt.setString(1, jarname);
```

```

        stmt.setString(2, resolutionPath);
        boolean isrs = stmt.execute();
        stmt.close();
        System.out.println("Alteration of JAR resolution path succeeded");
        con.commit();
        con.close();
    }
    catch (Exception e)
    {
        System.out.println("Alteration of JAR resolution path failed");
        e.printStackTrace ();
    }
}
}
}

```

Related concepts

[Definition of a JAR file for a Java routine to Db2 \(Db2 Application Programming for Java\)](#)

SQLJ.DB2_INSTALL_JAR stored procedure

SQLJ.DB2_INSTALL_JAR creates a new definition of a JAR file in the local Db2 catalog or in a remote Db2 catalog.

To install a JAR file at a remote location, you need to execute a CONNECT statement to connect to that location before you call SQLJ.DB2_INSTALL_JAR.

SQLJ.DB2_INSTALL_JAR authorization

Privilege set: If the CALL statement is embedded in an application program, the privilege set consists of the privileges that are held by the authorization ID of the owner of the plan or package. If the statement is dynamically prepared, the privilege set consists of the privileges that are held by the authorization IDs of the process.

For calling SQLJ.DB2_INSTALL_JAR, the privilege set must include at least one of the following items:

- EXECUTE privilege on SQLJ.DB2_INSTALL_JAR
- Ownership of SQLJ.DB2_INSTALL_JAR
- SYSADM authority

The privilege set must also include the authority to install a JAR, which consists of at least one of the following items:

- CREATEIN privilege on the schema of the JAR

The authorization ID that matches the schema name implicitly has the CREATEIN privilege on the schema.

- SYSADM or SYSCTRL authority

SQLJ.DB2_INSTALL_JAR syntax

►► CALL — SQLJ.DB2_INSTALL_JAR — (— *Jar-locator* , — *JAR-name* , — *deploy* —) ►►

SQLJ.DB2_INSTALL_JAR parameters

JAR-locator

A BLOB locator input parameter that points to the JAR file that is to be installed in the Db2 catalog.

JAR-name

A VARCHAR(257) input parameter that contains the Db2 name of the JAR, in the form *schema.JAR-id* or *JAR-id*. *JAR-name* is the name that you use when you refer to the JAR in SQL statements. If you omit *schema*, Db2 uses the SQL authorization ID that is in the CURRENT SCHEMA special register. The owner of the JAR is the authorization ID in the CURRENT SQLID special register.

deploy

An INTEGER input parameter that indicates whether additional actions are to be performed after the JAR file is installed. Additional actions are not supported, so this value is 0.

SQLJ.DB2_INSTALL_JAR example

Suppose that you want to install the JAR file that is in path /u/db2inst3/apps/BUILDPLAN/BUILDPLAN.jar. You want to refer to the JAR file as DB2INST3.BUILDPLAN in SQL statements. The following Java program installs that JAR file.

```
import java.sql.*; // JDBC classes
import java.io.IOException;
import java.io.File;
import java.io.FileInputStream;
class SimpleInstallJar
{
    public static void main (String argv[])
    {
        String url = "jdbc:db2://sysmvs1.stl.ibm.com:5021";
        String jarname = "DB2INST3.BUILDPLAN";
        String jarfile =
            "/u/db2inst3/apps/BUILDPLAN/BUILDPLAN.jar";
        try
        {
            Class.forName ("com.ibm.db2.jcc.DB2Driver").newInstance ();
            Connection con =
                DriverManager.getConnection(url, "MYID", "MYPW");
            File aFile = new File(jarfile);
            FileInputStream inputStream = new FileInputStream(aFile);
            CallableStatement stmt;
            String sql = "Call SQLJ.DB2_INSTALL_JAR(?, ?, ?)";
            stmt = con.prepareCall(sql);
            stmt.setBinaryStream(1, inputStream, (int)aFile.length());
            stmt.setString(2, jarname);
            stmt.setInt(3, 0);
            boolean isrs = stmt.execute();
            stmt.close();
            System.out.println("Installation of JAR succeeded");
            con.commit();
            con.close();
        }
        catch (Exception e)
        {
            System.out.println("Installation of JAR failed");
            e.printStackTrace ();
        }
    }
}
```

Related concepts

[Definition of a JAR file for a Java routine to Db2 \(Db2 Application Programming for Java\)](#)

SQLJ.DB2_REPLACE_JAR stored procedure

SQLJ.DB2_REPLACE_JAR replaces an existing JAR file in the local Db2 catalog or in a remote Db2 catalog.

To replace a JAR file at a remote location, you need to execute a CONNECT statement to connect to that location before you call SQLJ.DB2_REPLACE_JAR.

SQLJ.DB2_REPLACE_JAR authorization

Privilege set: If the CALL statement is embedded in an application program, the privilege set consists of the privileges that are held by the owner of the plan or package. If the statement is dynamically prepared, the privilege set consists of the privileges that are held by the authorization IDs of the process.

For calling SQLJ.DB2_REPLACE_JAR, the privilege set must include at least one of the following items:

- EXECUTE privilege on SQLJ.DB2_REPLACE_JAR
- Ownership of SQLJ.DB2_REPLACE_JAR

- SYSADM authority

The privilege set must also include the authority to replace a JAR, which consists of at least one of the following items:

- Ownership of the JAR
- ALTERIN privilege on the schema of the JAR

The authorization ID that matches the schema name implicitly has the ALTERIN privilege on the schema.

- SYSADM or SYSCTRL authority

SQLJ.DB2_REPLACE_JAR syntax

► CALL — SQLJ.DB2_REPLACE_JAR — (— JAR-locator , — JAR-name —) ►

SQLJ.DB2_REPLACE_JAR parameters

JAR-locator

A BLOB locator input parameter that points to the JAR file that is to be replaced in the Db2 catalog.

JAR-name

A VARCHAR(257) input parameter that contains the Db2 name of the JAR, in the form *schema.JAR-id* or *JAR-id*. *JAR-name* is the name that you use when you refer to the JAR in SQL statements. If you omit *schema*, Db2 uses the SQL authorization ID that is in the CURRENT SCHEMA special register.

SQLJ.DB2_REPLACE_JAR example

Suppose that you want to replace a previously installed JAR file that is named DB2INST3.BUILDPLAN with the JAR file that is in path /u/db2inst3/apps/BUILDPLAN2/BUILDPLAN.jar. The following Java program replaces the JAR file.

```
import java.sql.*; // JDBC classes
import java.io.IOException;
import java.io.File;
import java.io.FileInputStream;
class SimpleInstallJar
{
    public static void main (String argv[])
    {
        String url = "jdbc:db2://sysmvs1.stl.ibm.com:5021";
        String jarname = "DB2INST3.BUILDPLAN";
        String jarfile =
            "/u/db2inst3/apps/BUILDPLAN2/BUILDPLAN.jar";
        try
        {
            Class.forName ("com.ibm.db2.jcc.DB2Driver").newInstance ();
            Connection con =
                DriverManager.getConnection(url, "MYID", "MYPW");
            File aFile = new File(jarfile);
            FileInputStream inputStream = new FileInputStream(aFile);
            CallableStatement stmt;
            String sql = "Call SQLJ.DB2_REPLACE_JAR(?, ?)";
            stmt = con.prepareCall(sql);
            stmt.setBinaryStream(1, inputStream, (int)aFile.length());
            stmt.setString(2, jarname);
            boolean isrs = stmt.execute();
            stmt.close();
            System.out.println("Replacement of JAR succeeded");
            con.commit();
            con.close();
        }
        catch (Exception e)
        {
            System.out.println("Replacement of JAR failed");
            e.printStackTrace ();
        }
    }
}
```

Related concepts

[Definition of a JAR file for a Java routine to Db2 \(Db2 Application Programming for Java\)](#)

SQLJ.INSTALL_JAR stored procedure

SQLJ.INSTALL_JAR creates a new definition of a JAR file in the local Db2 catalog.

SQLJ.INSTALL_JAR authorization

Privilege set: If the CALL statement is embedded in an application program, the privilege set consists of the privileges that are held by the authorization ID of the owner of the plan or package. If the statement is dynamically prepared, the privilege set consists of the privileges that are held by the authorization IDs of the process.

For calling SQLJ.INSTALL_JAR, the privilege set must include at least one of the following items:

- EXECUTE privilege on SQLJ.INSTALL_JAR
- Ownership of SQLJ.INSTALL_JAR
- SYSADM authority

The privilege set must also include the authority to install a JAR, which consists of at least one of the following items:

- CREATEIN privilege on the schema of the JAR

The authorization ID that matches the schema name implicitly has the CREATEIN privilege on the schema.

- SYSADM or SYSCTRL authority

SQLJ.INSTALL_JAR syntax

► CALL — SQLJ.INSTALL_JAR — (— *url*, — *JAR-name*, — *deploy* —) ►

SQLJ.INSTALL_JAR parameters

url

A VARCHAR(1024) input parameter that identifies the z/OS UNIX System Services full path name for the JAR file that is to be installed in the Db2 catalog. The format is `file://path-name` or `file:/path-name`.

JAR-name

A VARCHAR(257) input parameter that contains the Db2 name of the JAR, in the form `schema.JAR-id` or `JAR-id`. *JAR-name* is the name that you use when you refer to the JAR in SQL statements. If you omit *schema*, Db2 uses the SQL authorization ID that is in the CURRENT SCHEMA special register. The owner of the JAR is the authorization ID in the CURRENT SQLID special register.

deploy

An INTEGER input parameter that indicates whether additional actions are to be performed after the JAR file is installed. Additional actions are not supported, so this value is 0.

SQLJ.INSTALL_JAR example

Suppose that you want to install the JAR file that is in path `/u/db2inst3/apps/BUILDPLAN/BUILDPLAN.jar`. You want to refer to the JAR file as `DB2INST3.BUILDPLAN` in SQL statements. Use a CALL statement similar to this one.

```
CALL SQLJ.INSTALL_JAR('file:/u/db2inst3/apps/BUILDPLAN/BUILDPLAN.jar',
'DB2INST3.BUILDPLAN',0)
```

Related concepts

[Definition of a JAR file for a Java routine to Db2 \(Db2 Application Programming for Java\)](#)

SQLJ.REMOVE_JAR stored procedure

SQLJ.REMOVE_JAR deletes a JAR file from the local Db2 catalog or from a remote Db2 catalog.

To delete a JAR file at a remote location, you need to execute a CONNECT statement to connect to that location before you call SQLJ.REMOVE_JAR.

The JAR cannot be referenced in the EXTERNAL NAME clause of an existing routine, or in the path of an installed JAR.

SQLJ.REMOVE_JAR authorization

Privilege set: If the CALL statement is embedded in an application program, the privilege set consists of the privileges that are held by the authorization ID of the owner of the plan or package. If the statement is dynamically prepared, the privilege set consists of the privileges that are held by the authorization IDs of the process.

For calling SQLJ.REMOVE_JAR, the privilege set must include at least one of the following items:

- EXECUTE privilege on SQLJ.REMOVE_JAR
- Ownership of SQLJ.REMOVE_JAR
- SYSADM authority

The privilege set must also include the authority to remove a JAR, which consists of at least one of the following items:

- Ownership of the JAR
- DROPIN privilege on the schema of the JAR

The authorization ID that matches the schema name implicitly has the DROPIN privilege on the schema.

- SYSADM or SYSCTRL authority

SQLJ.REMOVE_JAR syntax

► CALL — SQLJ.REMOVE_JAR — (— *JAR-name* , — *undeploy* —) ►

SQLJ.REMOVE_JAR parameters

JAR-name

A VARCHAR(257) input parameter that contains the Db2 name of the JAR that is to be removed from the catalog, in the form *schema.JAR-id* or *JAR-id*. *JAR-name* is the name that you use when you refer to the JAR in SQL statements. If you omit *schema*, Db2 uses the SQL authorization ID that is in the CURRENT SCHEMA special register.

undeploy

An INTEGER input parameter that indicates whether additional actions should be performed before the JAR file is removed. Additional actions are not supported, so this value is 0.

SQLJ.REMOVE_JAR example

Suppose that you want to remove a previously installed JAR file that is named DB2INST3.BUILDPLAN. Use a CALL statement similar to this one.

```
CALL SQLJ.REMOVE_JAR('DB2INST3.BUILDPLAN',0)
```

Related concepts

[Definition of a JAR file for a Java routine to Db2 \(Db2 Application Programming for Java\)](#)

SQLJ.REPLACE_JAR stored procedure

SQLJ.REPLACE_JAR replaces an existing JAR file in the local Db2 catalog.

SQLJ.REPLACE_JAR authorization

Privilege set: If the CALL statement is embedded in an application program, the privilege set consists of the privileges that are held by the authorization ID of the owner of the plan or package. If the statement is dynamically prepared, the privilege set consists of the privileges that are held by the authorization IDs of the process.

For calling SQLJ.REPLACE_JAR, the privilege set must include at least one of the following items:

- EXECUTE privilege on SQLJ.REPLACE_JAR
- Ownership of SQLJ.REPLACE_JAR
- SYSADM authority

The privilege set must also include the authority to replace a JAR, which consists of at least one of the following items:

- Ownership of the JAR
- ALTERIN privilege on the schema of the JAR

The authorization ID that matches the schema name implicitly has the ALTERIN privilege on the schema.

- SYSADM or SYSCTRL authority

SQLJ.REPLACE_JAR syntax

►► CALL — SQLJ.REPLACE_JAR — (— *url*, — *JAR-name* —) ►►

SQLJ.REPLACE_JAR parameters

url

A VARCHAR(1024) input parameter that identifies the z/OS UNIX System Services full path name for the JAR file that replaces the existing JAR file in the Db2 catalog. The format is `file://path-name` or `file:/path-name`.

JAR-name

A VARCHAR(257) input parameter that contains the Db2 name of the JAR, in the form `schema.JAR-id` or `JAR-id`. *JAR-name* is the name that you use when you refer to the JAR in SQL statements. If you omit *schema*, Db2 uses the SQL authorization ID that is in the CURRENT SCHEMA special register.

SQLJ.REPLACE_JAR example

Suppose that you want to replace a previously installed JAR file that is named DB2INST3.BUILDPLAN with the JAR file that is in path `/u/db2inst3/apps/BUILDPLAN2/BUILDPLAN.jar`. Use a CALL statement similar to this one.

```
CALL SQLJ.REPLACE_JAR('file:/u/db2inst3/apps/BUILDPLAN2/BUILDPLAN.jar',  
  'DB2INST3.BUILDPLAN')
```

Related concepts

[Definition of a JAR file for a Java routine to Db2 \(Db2 Application Programming for Java\)](#)

WLM_REFRESH stored procedure

The WLM_REFRESH stored procedure refreshes a WLM environment. This stored procedure can recycle the environment in which it runs and in any other WLM environment.

Environment for WLM_REFRESH

The load module for WLM_REFRESH, DSNTWR, must reside in an APF-authorized library.

DSNTWR runs module DSNTWRE as a subtask. DSNTWRE retrieves a copy of the Db2 environment information block (EIB) for the Db2 subsystem. The DSNTWRE module has no APF-authorization requirement, but it must reside in an APF-authorized library to be available to DSNTWR.

Recommendation: Use WLM environment DSNWLM_GENERAL for running WLM_REFRESH. Installation job DSNTIJMV creates an address space procedure called DSNWLMG for this environment.

Authorization required for WLM_REFRESH

To execute the CALL statement, the SQL authorization ID of the process must have READ access or higher to the z/OS Security Server System Authorization Facility (SAF) resource profile *ssid.WLM_REFRESH.WLM-environment-name* in resource class DSNR. This is a different resource profile from the *ssid.WLMENV.WLM-environment-name* resource profile, which Db2 uses to determine whether a stored procedure or user-defined function is authorized to run in the specified WLM environment.

WLM_REFRESH uses an extended MCS console to monitor the operating system response to a WLM environment refresh request. The privilege to create an extended MCS console is controlled by the resource profile MVS.MCSOPER.* in the OPERCMDS class. If the MVS.MCSOPER.* profile exists, or if the specific profile MVS.MCSOPER.DSNTWR exists, the task ID that is associated with the WLM environment in which WLM_REFRESH runs must have READ access to it.

If the MVS.VARY.* profile exists, or if the specific profile MVS.VARY.WLM exists, the task ID that is associated with the WLM environment in which WLM_REFRESH runs must have CONTROL access to it.

WLM_REFRESH syntax diagram

The WLM_REFRESH stored procedure refreshes a WLM environment. WLM_REFRESH can recycle the environment in which it runs, as well as any other WLM environment.

The following syntax diagram shows the SQL CALL statement for invoking WLM_REFRESH. The linkage convention for WLM_REFRESH is GENERAL WITH NULLS.

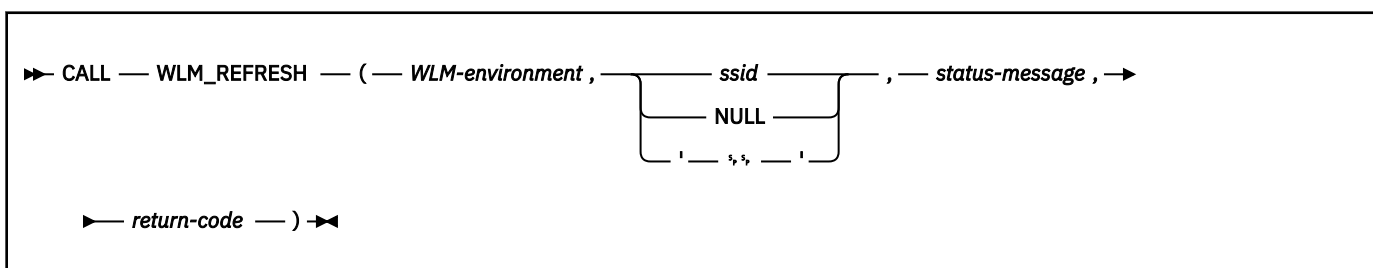

WLM_REFRESH option descriptions

WLM-environment

Specifies the name of the WLM environment that you want to refresh. This is an input parameter of type VARCHAR(32).

ssid

Specifies the subsystem ID of the Db2 subsystem with which the WLM environment is associated. If this parameter is NULL or blank, Db2 uses one of the following values for this parameter:

- In a non-data sharing environment, Db2 uses the subsystem ID of the subsystem on which WLM_REFRESH runs.
- In a data sharing environment, Db2 uses the group attach name for the data sharing group in which WLM_REFRESH runs.

This is an input parameter of type VARCHAR(4).

status-message

Contains an informational message about the execution of the WLM refresh. This is an output parameter of type VARCHAR(120).

return-code

Contains the return code from the WLM_REFRESH call, which is one of the following values:

0

WLM_REFRESH executed successfully.

4

One of the following conditions exists:

- The SAF resource profile *ssid.WLM_REFRESH.wlm-environment* is not defined in resource class DSNR.
- The SQL authorization ID of the process (CURRENT SQLID) is not defined to SAF.
- The wait time to obtain a response from z/OS was exceeded.

8

The SQL authorization ID of the process (CURRENT SQLID) is not authorized to refresh the WLM environment.

990

DSNTWR received an unexpected SQLCODE while determining the current SQLID.

993

One of the following conditions exists:

- The *WLM-environment* parameter value is null, blank, or contains invalid characters.
- The *ssid* value contains invalid characters.

994

The extended MCS console was not activated within the number of seconds indicated by message DSNT5461.

995

DSNTWR is not running as an authorized program.

996

DSNTWR could not activate an extended MCS console. See message DSNT533I for more information.

997

DSNTWR made an unsuccessful request for a message from its extended MCS console. See message DSNT533I for more information.

998

The extended MCS console for DSNTWR posted an alert. See message DSNT534I for more information.

999

The operating system denied an authorized WLM_REFRESH request. See message DSNT545I for more information.

return-code is an output parameter of type INTEGER.

Example of WLM_REFRESH invocation

Suppose that you want to refresh WLM environment WLMENV1, which is associated with a Db2 subsystem with ID DSN. Assume that you already have READ access to the DSN.WLM_REFRESH.WLMENV1 SAF profile. The CALL statement for WLM_REFRESH looks like this:

```
stcpy(WLMENV,"WLMENV1");
stcpy(SSID,"DSN");
EXEC SQL CALL SYSPROC.WLM_REFRESH(:WLMENV, :SSID, :MSGTEXT, :RC);
```

For a complete example of setting up access to an SAF profile and calling WLM_REFRESH, see job DSNTEJ6W, which is in data set *prefix*.SDSNSAMP.

Related information

[Controlling extended MCS consoles using RACF \(z/OS MVS Planning: Operations\)](#)

WLM_SET_CLIENT_INFO stored procedure

This procedure allows the caller to set client information that is associated with the current connection at the Db2 for z/OS server.

The following Db2 for z/OS client special registers can be changed:

- CURRENT_CLIENT_ACCTNG
- CURRENT_CLIENT_USERID
- CURRENT_CLIENT_WRKSTNNAME
- CURRENT_CLIENT_APPLNAME

The existing behavior of the CLIENT_ACCTNG register is unchanged. It gets its value from the accounting token for DSN requesters, and from the accounting string for SQL and other requesters.

Setting the CLIENT_ACCTNG special register updates the suffix portion of the accounting string. The accounting suffix information is limited to 255 bytes for distributed clients

This procedure is not under transaction control and client information changes made by the procedure are independent of committing or rolling back units of work.

Environment

WLM_SET_CLIENT_INFO runs in a WLM-established stored procedures address space.

Authorization

To execute the CALL statement, the owner of the package or plan that contains the CALL statement must have one or more of the following privileges on each package that the stored procedure uses:

- The EXECUTE privilege on the package for DSNADMSI
- Ownership of the package
- PACKADM authority for the package collection
- SYSADM authority

Syntax

```
► WLM_SET_CLIENT_INFO ( ( client_userid , client_wrkstnname ,
                          NULL NULL
                          , client_applname , client_acctstr ) ►
                          NULL NULL ) ►
```

The schema is SYSPROC.

Procedure parameters

client_userid

An input parameter of type VARCHAR(255) that specifies the user ID for the client. If NULL is specified, the value remains unchanged. If an empty string ("") is specified, the user ID for the client is reset to the default value.

If the value specified exceeds 128 bytes, it is truncated to 128 bytes.

client_wrkstnname

An input parameter of type VARCHAR(255) that specifies the workstation name for the client. If NULL is specified, the value remains unchanged. If an empty string ("") is specified, the workstation name for the client is reset to the default value.

client_applname

An input parameter of type VARCHAR(255) that specifies the application name for the client. If NULL is specified, the value remains unchanged. If an empty string ("") is specified, the application name for the client is reset to the default value.

client_acctstr

An input parameter of type VARCHAR(255) that specifies the accounting string for the client. If NULL is specified, the value remains unchanged. If an empty string ("") is specified, the accounting string for the client is reset to the default value.

Examples

Set the user ID, workstation name, application name, and accounting string for the client.

```
strcpy(user_id, "db2user");
strcpy(wkstn_name, "mywkstn");
strcpy(appl_name, "db2bp.exe");
strcpy(acct_str, "myacctstr");
iuser_id = 0;
iwkstn_name = 0;
iappl_name = 0;
iacct_str = 0;
EXEC SQL CALL SYSPROC.WLM_SET_CLIENT_INFO(:user_id:iuser_id, :wkstn_name:iwkstn_name,
                                          :appl_name:iappl_name, :acct_str:iacct_str);
```

Set the user ID to db2user for the client without setting the other client attributes.

```
strcpy(user_id, "db2user");
iuser_id = 0;
iwkstn_name = -1;
iappl_name = -1;
iacct_str = -1;
EXEC SQL CALL SYSPROC.WLM_SET_CLIENT_INFO(:user_id:iuser_id, :wkstn_name:iwkstn_name,
                                          :appl_name:iappl_name, :acct_str:iacct_str);
```

Reset the user ID for the client to blank without modifying the values of the other client attributes.

```
strcpy(user_id, "");
iuser_id = 0;
iwkstn_name = -1;
iappl_name = -1;
iacct_str = -1;
EXEC SQL CALL SYSPROC.WLM_SET_CLIENT_INFO(:user_id:iuser_id, :wkstn_name:iwkstn_name,
                                          :appl_name:iappl_name, :acct_str:iacct_str);
```

XSR_ADDSCHEMADOC stored procedure

The XSR_ADDSCHEMADOC stored procedure adds every XML schema, other than the primary XML schema document, to the XSR.

Each XML schema in the XSR can consist of one or more XML schema documents. When an XML schema consists of multiple documents, you need to call XSR_ADDSCHEMADOC for the additional documents.

Environment for XSR_ADDSCHEMADOC

XSR_ADDSCHEMADOC runs in a WLM-established stored procedures address space.

Recommendation: Use WLM environment DSNWLM_XML for running XSR_ADDSCHEMADOC. The startup procedure for this environment, DSNWLMX, can be configured during installation, using installation panel DSNTIPRJ, XML schema processing routines.

Authorization required for XSR_ADDSCHEMADOC

The user ID of the caller of the procedure must have the EXECUTE privilege on the XSR_ADDSCHEMADOC stored procedure.

XSR_ADDSCHEMADOC syntax diagram

The following syntax diagram shows the CALL statement for invoking XSR_ADDSCHEMADOC.

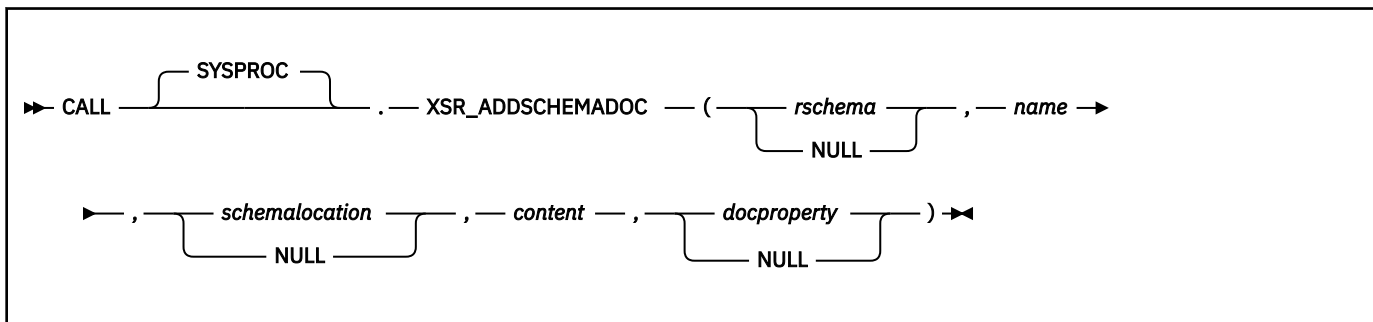

rschema

An input parameter of type VARCHAR (128) that specifies the SQL schema part of the qualified name that identifies the XML schema in the XSR. If a non-null value is specified, it must be SYSXSR. If *rschema* is a null value, the default SQL schema SYSXSR is used.

name

An input parameter of type VARCHAR(128) that specifies the name of the XML schema. The complete qualified name for the XML schema is *rschema.name*, and it should be unique among all objects in the XSR. If a null value is specified, a unique value is generated and stored within the XSR. Rules for valid characters and delimiters that apply to any SQL identifier also apply to *name*

schemalocation

An input parameter of type VARCHAR(1000), which can have a null value, that indicates the schema location of the primary XML schema document to which the XML schema document is being added. This argument is the *external name* of the XML schema, that is, the primary document can be identified in the XML instance documents with the *xsi:schemaLocation* attribute. The document that references the *schemalocation* must use valid a URI format.

content

An input parameter of type BLOB(30M) that contains the content of the XML schema document being added. This argument cannot have a null value. An XML schema document must be supplied. The content of the XML schema document must be encoded in Unicode.

docproperty

An input parameter of type BLOB(5M) that indicates the properties for the XML schema document being added. This parameter can be an XML document or a null value.

Example of XSR_ADDSCHEMADOC

The following example calls the XSR_ADDSCHEMADOC stored procedure:

```
CALL SYSPROC.XSR_ADDSCHEMADOC(  
  'SYSXSR',  
  'POschema',  
  'http://myPOschema/PO.xsd',
```

```
:schema_content,  
:schema_properties)
```

In this example, XSR_ADDSCHEMADOC folds the name POschema to uppercase, so the name of the XML schema that is added is POSCHEMA. If you do not want XSR_ADDSCHEMADOC to fold POschema to uppercase, you need to delimit the name with double quotation marks ("), as in the following example.

```
CALL SYSPROC.XSR_ADDSCHEMADOC(  
  'SYSXSR',  
  "POschema",  
  'http://myPOschema/PO.xsd',  
  :schema_content,  
  :schema_properties)
```

Related concepts

[The Db2 command line processor \(Db2 Commands\)](#)

[Example of XML schema registration and removal using stored procedures \(Db2 Programming for XML\)](#)

XSR_COMPLETE stored procedure

The XSR_COMPLETE procedure is the final stored procedure to be called as part of the XML schema registration process, which registers XML schemas with the XSR.

An XML schema is not available for validation until the schema registration completes through a call to this stored procedure.

Environment for XSR_COMPLETE

XSR_COMPLETE requires a WLM-established stored procedures address space that is configured for running Java routines.

Recommendation: Use WLM environment DSNWLM_JAVA for running XSR_COMPLETE. The startup procedure for this environment, DSNWLMJ, can be configured during installation, using installation panel DSNTIPRH, XML schema processing routines.

Authorization required for XSR_COMPLETE

The user ID of the caller of the procedure must have the EXECUTE privilege on the XSR_COMPLETE stored procedure.

XSR_COMPLETE syntax diagram

The following syntax diagram shows the CALL statement for invoking XSR_COMPLETE.

```
CALL SYSPROC.XSR_COMPLETE ( rschema , name , schema-properties , for-decomposition )
```

rschema

An input parameter of type VARCHAR (128) that specifies the SQL schema part of the qualified name that identifies the XML schema in the XSR. If a non-null value is specified, it must be SYSXSR. If *rschema* is a null value, the default SQL schema SYSXSR is used.

name

An input parameter of type VARCHAR(128) that specifies the name of the XML schema. The complete qualified name for the XML schema is *rschema.name*, and it should be unique among all objects in the XSR. If a null value is specified, a unique value is generated and stored within the XSR. Rules for valid characters and delimiters that apply to any SQL identifier also apply to *name*.

schema-properties

An input parameter of type BLOB(5M) that specifies properties, associated with the XML schema. The argument can be an XML document that represents properties for the XML schema, or a null value.

for-decomposition

This value must be 0. XML schema decomposition is not supported.

Example of XSR_COMPLETE

The following example calls the XSR_COMPLETE stored procedure:

```
CALL SYSPROC.XSR_COMPLETE(  
  'SYSXSR',  
  'POschema',  
  :schemaproperty_host_var,  
  0)
```

In this example, XSR_COMPLETE folds the name POschema to uppercase, so the name of the XML schema for which registration is completed is POSCHEMA. If you do not want XSR_COMPLETE to fold POschema to uppercase, you need to delimit the name with double quotation marks ("), as in the following example.

```
CALL SYSPROC.XSR_COMPLETE(  
  'SYSXSR',  
  '"POschema"',  
  :schemaproperty_host_var,  
  0)
```

Related concepts

[Example of XML schema registration and removal using stored procedures \(Db2 Programming for XML\)](#)

[The Db2 command line processor \(Db2 Commands\)](#)

Related tasks

[Additional steps for enabling the stored procedures and objects for XML schema support \(Db2 Installation and Migration\)](#)

XSR_REGISTER stored procedure

The XSR_REGISTER procedure is the first stored procedure to be called as part of the XML schema registration process, which registers XML schemas with the XSR.

The user that calls this stored procedure is considered the creator of this XML schema. Db2 obtains the namespace attribute from the schema document when XSR_COMPLETE is invoked.

Environment for XSR_REGISTER

XSR_REGISTER runs in a WLM-established stored procedures address space.

Recommendation: Use WLM environment DSNWLM_XML for running XSR_REGISTER. The startup procedure for this environment, DSNWLMX, can be configured during installation, using installation panel DSNTIPRJ, XML schema processing routines.

Authorization required for XSR_REGISTER

The user ID of the caller of the procedure must have the EXECUTE privilege on the XSR_REGISTER stored procedure.

XSR_REGISTER syntax diagram

The following syntax diagram shows the CALL statement for invoking XSR_REGISTER.

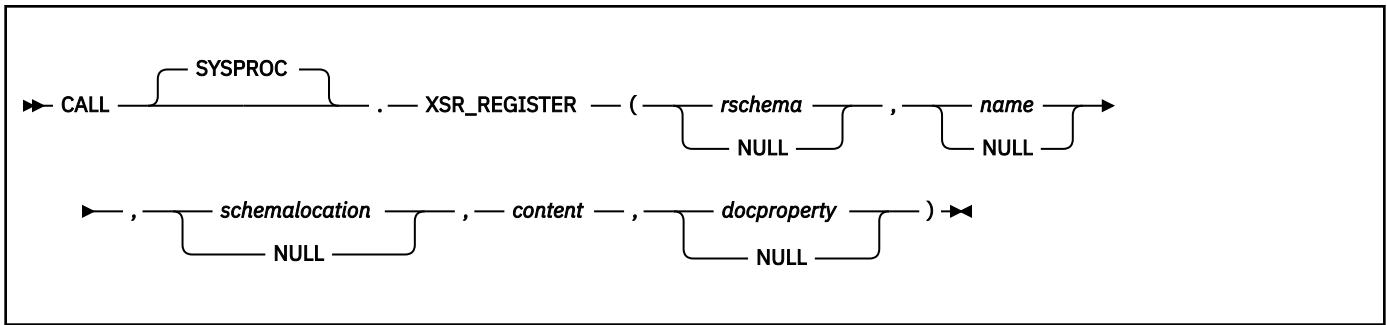

rschema

An input parameter of type VARCHAR (128) that specifies the SQL schema part of the qualified name that identifies the XML schema in the XSR. If a non-null value is specified, it must be SYSXSR. If *rschema* is a null value, the default SQL schema SYSXSR is used.

name

An input and output parameter of type VARCHAR(128) that specifies the name of the XML schema. The complete SQL identifier for the XML schema is *rschema.name*, and it should be unique among all objects in the XSR. If a null value is specified, a unique value is generated and stored within the XSR. Rules for valid characters and delimiters that apply to any SQL identifier also apply to *name*.

schemalocation

An input parameter of type VARCHAR(1000), which can have a null value, that indicates the schema location of the primary XML schema document. This argument is the *external name* of the XML schema, that is, the primary document can be identified in the XML instance documents with the xsi:schemaLocation attribute.

content

An input parameter of type BLOB(30M) that contains the content of the primary XML schema document. This argument cannot have a null value; an XML schema document must be supplied. The content of the XML schema document must be encoded in Unicode.

docproperty

An input parameter of type BLOB(5M) that indicates the properties for the primary XML schema document. This parameter can be an XML document or a null value.

Example of XSR_REGISTER

The following example calls the XSR_REGISTER stored procedure:

```
CALL SYSPROC.XSR_REGISTER(
  'SYSXSR',
  'POschema',
  'http://myPOschema/PO.xsd',
  :content_host_var,
  :docproperty_host_var)
```

In this example, XSR_REGISTER folds the name POschema to uppercase, so the registered schema name is POSCHEMA. If you do not want XSR_REGISTER to fold POschema to uppercase, you need to delimit the name with double quotation marks ("), as in the following example.

```
CALL SYSPROC.XSR_REGISTER(
  'SYSXSR',
  "POschema",
  'http://myPOschema/PO.xsd',
  :content_host_var,
  :docproperty_host_var)
```

Related concepts

- [Example of XML schema registration and removal using stored procedures \(Db2 Programming for XML\)](#)
- [The Db2 command line processor \(Db2 Commands\)](#)

XSR_REMOVE stored procedure

The XSR_REMOVE procedure is used to remove all components of an XML schema. After the XML schema is removed, you can reuse the name of the removed XML schema when you register a new XML schema.

Environment for XSR_REMOVE

XSR_REMOVE runs in a WLM-established stored procedures address space.

Recommendation: Use WLM environment DSNWLM_XML for running XSR_REMOVE. The startup procedure for this environment, DSNWLMX, can be configured during installation, using installation panel DSNTIPRJ, XML schema processing routines.

Authorization required for XSR_REMOVE

The user ID of the caller of the procedure must have the EXECUTE privilege on the XSR_REMOVE stored procedure.

XSR_REMOVE syntax diagram

The following syntax diagram shows the CALL statement for invoking XSR_REMOVE.

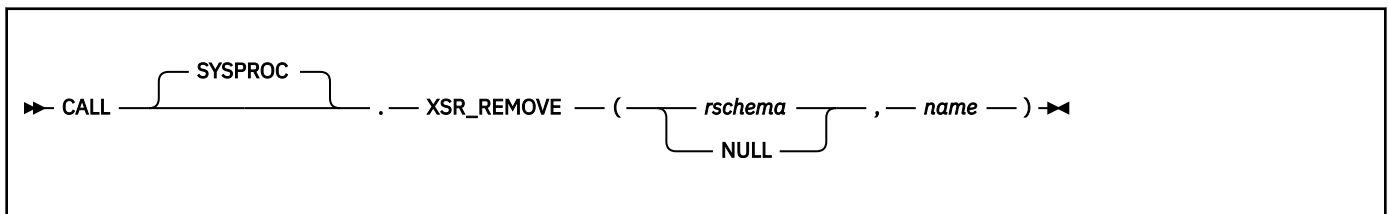

rschema

An input parameter of type VARCHAR (128) that specifies the SQL schema part of the qualified name that identifies the XML schema in the XSR. If a non-null value is specified, it must be SYSXSR. If *rschema* is a null value, the default SQL schema SYSXSR is used.

name

An input parameter of type VARCHAR(128) that specifies the name of the XML schema. The complete qualified name for the XML schema is *rschema.name*, and it should be unique among all objects in the XSR. If a null value is specified, a unique value is generated and stored within the XSR. Rules for valid characters and delimiters that apply to any SQL identifier also apply to *name*.

XSR_REMOVE notes

If you run XSR_REMOVE against an XML schema that is part of an XML type modifier for a table column, an error occurs.

Example of XSR_REMOVE

The following example calls the XSR_REMOVE stored procedure:

```
CALL SYSPROC.XSR_REMOVE(  
  'SYSXSR',  
  'POschema')
```

In this example, XSR_REMOVE folds the name POschema to uppercase, so the name of the XML schema that is removed is POSCHEMA. If you do not want XSR_REMOVE to fold POschema to uppercase, you need to delimit the name with double quotation marks ("), as in the following example.

```
CALL SYSPROC.XSR_REMOVE(  
  'SYSXSR',  
  '"POschema"')
```

Related concepts

[The Db2 command line processor \(Db2 Commands\)](#)

[Example of XML schema registration and removal using stored procedures \(Db2 Programming for XML\)](#)

[XML schema validation with an XML type modifier \(Db2 Programming for XML\)](#)

Chapter 6. Queries

A *query* specifies a result table or an intermediate table. A query is a component of certain SQL statements.

A query can have one of the following forms:

- [“subselect” on page 1009](#)
- [“fullselect” on page 1060](#)
- [“select-statement” on page 1067](#)

A *subselect* is a subset of a *fullselect*, and a *fullselect* is a subset of a *select-statement*.

Restriction: For all three forms of a query, you cannot reference both a system-period temporal table and an archive-enabled table in the same query.

Another SQL statement that can be used to retrieve at most a single row is described in [“SELECT INTO statement” on page 2117](#). SELECT INTO is not a *subselect*, *fullselect*, or a *select-statement*.

Related concepts

[Types of tables \(Db2 Administration Guide\)](#)

[Temporal tables and data versioning \(Db2 Administration Guide\)](#)

[Archive-enabled tables and archive tables \(Introduction to Db2 for z/OS\)](#)

Authorization for queries

The same authorization rules apply to the SELECT statement, the *fullselect*, *select-statement*, and *subselect* query forms.

For any form of a query, the privilege set that is defined below must include one of the following authorities or privilege sets:

- For each table or view identified in the statement, the privilege set must include one of the following:
 - Ownership of the table or view
 - The SELECT privilege on the table or view
 - DBADM authority for the database (tables only)

If the database is implicitly created, the database privileges must be on the implicit database or on DSND04.

- SYSADM authority
- SYSCTRL authority (catalog tables only)
- DATAACCESS authority
- Installation SYSOPR authority (catalog tables and system tables only)

If a query includes a user-defined function, the privileges that are held by the authorization ID of the statement must include at least one of the following:

- For each user-defined function that is identified in the statement, one of the following:
 - The EXECUTE privilege on the function
 - Ownership of the function
- SYSADM authority
- DATAACCESS authority

If a query includes a sequence object, the privileges that are held by the authorization ID of the statement must include at least one of the following:

- For each sequence object that is identified in the statement, one of the following:
 - The USAGE privilege on the sequence object
 - Ownership of the sequence object
- DATAACCESS authority

If the *select-statement* is part of a DECLARE CURSOR statement, the privilege set is the privileges that are held by the authorization ID of the owner of the plan or package.

If the *select-statement* contains an SQL data change statement, the privilege set must include the SELECT privilege and the appropriate privileges for the SQL data change statement (insert, update, or delete privileges) on the target table or view.

If the *select-statement* references a table that contain an active row or column access control, and row permissions or column masks are defined for the table, the authorization ID or role of the statement does not need authority to reference objects that are specified in the definitions of those row permissions or column masks.

Privilege sets for queries

If the statement is embedded in an application program, the privilege set is the privileges that are held by the owner of the plan or package.

If the statement is dynamically prepared, and the application is bound in a trusted context, the privilege set is the set of privileges that are held by that role. Otherwise, the privilege set depends on the dynamic SQL statement behavior, which is specified by option DYNAMICRULES:

Run behavior

The privilege set is the union of the privilege sets that are held by each authorization ID of the process.

Bind behavior

The privilege set is the privileges that are held by the authorization ID of the owner of the plan or package.

Define behavior

The privilege set is the privileges that are held by the authorization ID of the owner of the stored procedure or user-defined function.

Invoke behavior

The privilege set is the privileges that are held by the authorization ID of the invoker of the stored procedure or user-defined function.

For a list of the DYNAMICRULES values that specify run, bind, define, or invoke behavior, see [Table 14 on page 94](#).

When any form of a query is used as a component of another statement, the authorization rules that apply to the query are specified in the description of that statement. For example, see the authorization rules that apply to the *subselect* in a CREATE VIEW statement in [“CREATE VIEW statement” on page 1812](#).

If your installation uses the access control authorization exit (DSNX@XAC), that exit might be controlling the authorization rules instead of the rules that are listed here.

Related reference

[subselect](#)

The *subselect* is a component of the fullselect. A subselect specifies a result table that is derived from the tables or views that are identified in the FROM clause.

[fullselect](#)

The fullselect is a component of the *select-statement*, ALTER TABLE statement for the definition of a materialized query table, CREATE TABLE statement, CREATE VIEW statement, DECLARE GLOBAL TEMPORARY TABLE statement, INSERT statement, UPDATE statement, and MERGE statement.

[select-statement](#)

The *select-statement* is the form of a query that can be directly specified in a DECLARE CURSOR statement or FOR statement, prepared and then referenced in a DECLARE CURSOR statement, or directly specified in an SQLJ assignment clause. It can also be issued using SPUFI or the command line processor which causes a result table to be displayed at your terminal. In any case, the result table specified by a *select-statement* is the result of the *fullselect*.

subselect

The *subselect* is a component of the fullselect. A subselect specifies a result table that is derived from the tables or views that are identified in the FROM clause.

Authorization for *subselect*

See “Authorization for queries” on page 1007.

Syntax for *subselect*

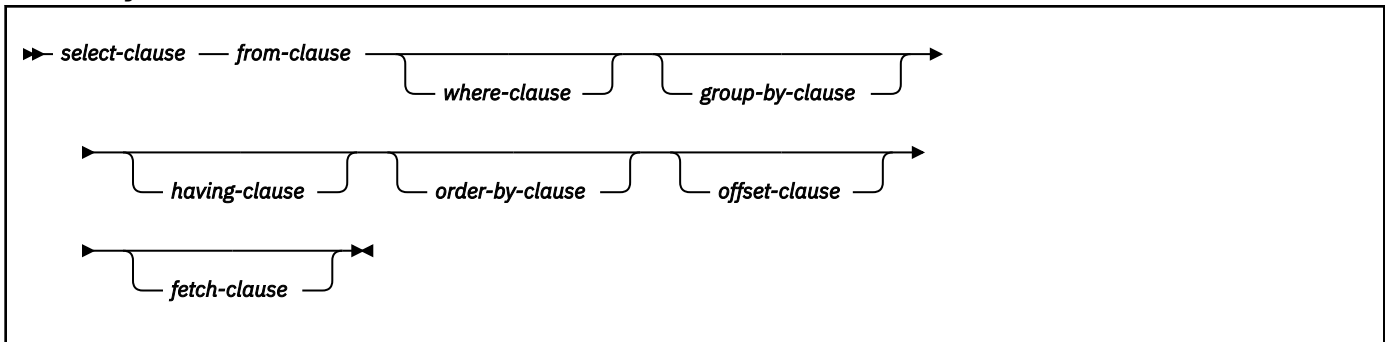

Description

The derivation of the result table can be described as a sequence of operations in which the result of each operation is input for the next. (This is only a way of describing the subselect. The method that is used to perform the derivation might be quite different from this description. If portions of the subselect do not actually need to be executed for the correct result to be obtained, they might not be executed.)

When a subselect directly or indirectly references a table for which row or column access control is enforced, the rules that are defined in the row permissions or column masks affect how the rows in the result table are derived. Typically those rules are based on the authorization ID or role of the process.

A *scalar-subselect* is a subselect, enclosed in parentheses, that returns a single result row and a single result column. If the result of the subselect is no rows, the null value is returned. An error is returned if the result contains more than one row.

The clauses of the subselect are processed in the following sequence:

1. FROM clause
2. WHERE clause
3. GROUP BY clause
4. HAVING clause
5. SELECT clause
6. ORDER BY clause
7. OFFSET clause
8. FETCH clause

Related reference

[SELECT statement](#)

The *select-statement* is the form of a query that can be directly specified in a DECLARE CURSOR statement, or prepared and then referenced in a DECLARE CURSOR statement. It can also be issued interactively using SPUFI or the command line processor which causes a result table to be displayed at your terminal. In any case, the table specified by *select-statement* is the result of the fullselect.

select-statement

The *select-statement* is the form of a query that can be directly specified in a DECLARE CURSOR statement or FOR statement, prepared and then referenced in a DECLARE CURSOR statement, or directly specified in an SQLJ assignment clause. It can also be issued using SPUFI or the command line processor which causes a result table to be displayed at your terminal. In any case, the result table specified by a *select-statement* is the result of the *fullselect*.

fullselect

The fullselect is a component of the *select-statement*, ALTER TABLE statement for the definition of a materialized query table, CREATE TABLE statement, CREATE VIEW statement, DECLARE GLOBAL TEMPORARY TABLE statement, INSERT statement, UPDATE statement, and MERGE statement.

select-clause

The SELECT clause specifies the columns of the final result table. The column values are produced by the application of the *select list* to R. The select list is a list of names and expressions specified in the SELECT clause, and R is the result of the previous operation of the subselect. For example, if SELECT, FROM, and WHERE are the only clauses specified, then R is the result of that WHERE clause.

select-clause

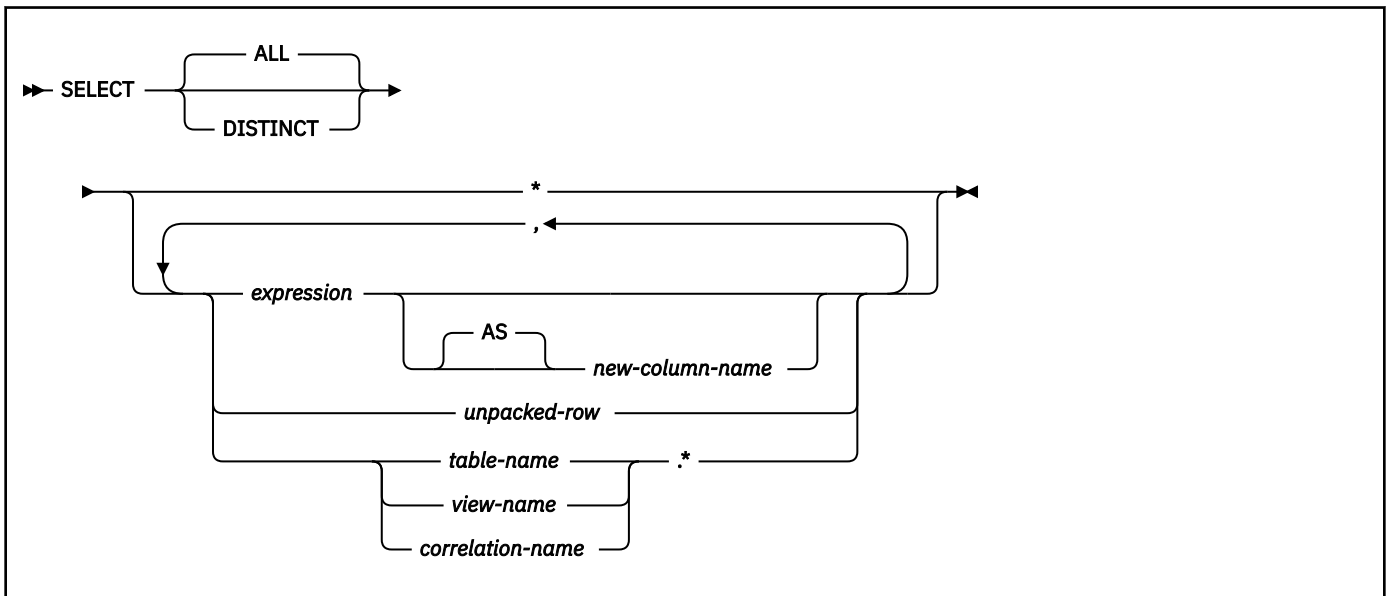

ALL

Retains all rows of the final result table and does not eliminate redundant duplicates. This is the default.

DISTINCT

Eliminates all but one of each set of duplicate rows of the final result table.

Two rows are duplicates of one another only if each value in the first row is equal to the corresponding value in the second row. For determining duplicate rows, two null values are considered equal.

When SELECT DISTINCT is specified, no column or expression in the implicit or explicit list can return a value that is a LOB or XML data type. When a column or expression in the list returns a value that is a DECFLOAT data type and multiple bit representations of the same number exists in the intermediate result, the value that is returned is unpredictable. See [“Numeric comparisons” on page 156](#) for additional information.

Column access controls do not affect the operation of SELECT DISTINCT. The elimination of duplicated rows is based on the original column values, not the masked values. However, after the application of column masks, the masked values in the final result table might not reflect the uniqueness that is enforced by SELECT DISTINCT.

If a column mask is applied to a column that directly or indirectly derives the result of SELECT DISTINCT, SELECT DISTINCT can return a result that is not deterministic. The following conditions are a few examples of when a result that is not deterministic might be returned:

- The definition of the column mask references other columns of the table to which the column mask is applied.
- The column is referenced in the argument of a built-in scalar function, such as COALESCE, IFNULL, NULLIF, MAX, MIN, LOCATE, TOTALORDER, etc.
- The column is referenced in the argument of an aggregation function.
- The column is embedded in an expression and the expression contains a function that is not deterministic or has an external action.

For compatibility with other SQL implementations, UNIQUE can be specified as a synonym for DISTINCT.

Select list notation:

Represents a list of columns of table R, excluding any columns that are defined with the IMPLICITLY HIDDEN attribute. The list of names is established when the statement containing the SELECT clause is prepared. Therefore, * does not identify any columns that have been added to a table after the statement has been prepared.

A column that is defined with the IMPLICITLY HIDDEN attribute can be explicitly referenced in the select list.

* cannot be used in the definition of a row permission or a column mask.

expression

Specifies the values of a result column. Each *column-name* in the expression must unambiguously identify a column of the intermediate result table.

The result of the expression must not be an array type, except in the following contexts:

- The outer select list of a fullselect that does not include a set operator other than UNION ALL, in the definition of a cursor that is not scrollable
- The outer select list of a SELECT INTO statement, when the target for the corresponding column of the result table of the fullselect is an array variable
- The outer select list of a scalar fullselect that does not include a set operator on the right side of a SET *assignment-statement* or SQL PL *assignment-statement* statement, when the corresponding target of the assignment is an array variable

AS new-column-name

Names or renames the result column. The name must not be qualified and does not have to be unique. *new-column-name* is an SQL identifier of 128 UTF-8 bytes or less.

name.*

Represents a list of columns of *name*, excluding any columns that are defined as implicitly hidden, in the order the columns are produced by the FROM clause. *name* can be a table name, view name, or correlation name, and must designate an exposed table, view, or correlation name in the FROM clause that immediately follows the SELECT clause. The first name in the list identifies the first column of the table or view, the second name in the list identifies the second column of the table or view, and so on.

The list of names is established when the statement that contains the SELECT clause is prepared. Therefore, * does not identify any columns that have been added to a table after the statement has been prepared.

*name.** cannot be used in the definition of a row permission or a column mask.

SQL statements can be implicitly or explicitly prepared again. The effect of another prepare on statements that include * or *name.** is that the list of names is re-established. Therefore, the number of columns returned by the statement might change.

The number of columns in the result of SELECT is the same as the number of expressions in the operational form of the select list (that is, the list established at the time the statement is prepared), and cannot exceed 750. The result of a subquery must be a single column unless the subquery is used in an EXISTS predicate.

Notes:

If the FROM clause contains a MERGE statement:

The SELECT list must not implicitly or explicitly refer to a column that has a LOB data type, a ROWID data type (or a distinct type that is based on a LOB, or ROWID), or an XML data type.

Implicitly hidden columns in the select list:

The result for SELECT * does not include any columns that are defined with the IMPLICITLY HIDDEN attribute. To be included in the result, implicitly hidden columns must be explicitly specified in the select list.

VARBINARY data:

If the identified table has an index on a VARBINARY column or a column that is a distinct type that is based on VARBINARY data type, that index column cannot specify the DESC attribute. To query the identified table, either drop the index or alter the data type of the column to BINARY and then rebuild the index.

Applying the select list:

Some of the results of applying the select list to R depend on whether GROUP BY or HAVING is used. The following three lists describe the results.

IF neither GROUP BY nor HAVING is used:

- The select list can include aggregate functions only if it includes other aggregate functions, constants, or expressions that only involve constants.
- If the select list does not include aggregate functions, it is applied to each row of R and the result contains as many rows as there are rows in R.
- If the select list includes aggregate functions, R is the source of the arguments of the functions and the result of applying the select list is one row, even when R has no rows.
- If a column mask is used to mask the values in the final result table, and the select list includes aggregate functions, the definition of the column mask must not reference the following:
 - A scalar fullselect
 - An aggregate function

If HAVING is used and GROUP BY is not used:

Each expression or *column-name* in an expression in the select list must be specified within an aggregate function. Constants or expressions that involve only constants can also be in the select list.

If a column mask is used to mask the values in the final result table, the definition of the column mask must not reference the following:

- A scalar fullselect
- An aggregate function

If GROUP BY is used:

- Each expression in the select list must use one or more grouping expressions. Or, each expression or *column-name* in an expression must:
 - Unambiguously identify a grouping column of R.
 - Be specified within an aggregate function.

- Be a correlated reference. (A column-name is a correlated reference if it identifies a column of a table or view identified in an outer subselect.)
- If an expression in the select list is a scalar fullselect, a correlated reference from the scalar fullselect to a group R must either identify a grouping column or be contained within an aggregate function. For example, the following query fails because the correlated reference T1.C1 || T1.C2 in the select list of the scalar fullselect does not match a grouping column from the outer subselect. (Matching the grouping expression T1.C1 || T1.C2 is not supported.)

```
SELECT MAX(T1.C2) AS X1,
       (SELECT T1.C1 || T1.C2 FROM T2 GROUP BY T2.C1) AS Y1
FROM T1
GROUP BY T1.C1, T1.C1 || T1.C2;
```

- You cannot use GROUP BY with a name defined using the AS clause unless the name is defined in a nested table expression. [Example 6](#) demonstrates the valid use of AS and GROUP BY in a SELECT statement.

In either case, the *n*th column of the result contains the values specified by applying the *n*th expression in the operational form of the select list.

If a column mask is used to mask the column values in the final result table, a column for which the column mask is applied must satisfy one of the following conditions:

- The column must be specified in an aggregate function and the definition of the column mask must not reference the following:
 - A scalar fullselect
 - An aggregate function
- The column must identify a *column-name* in the GROUP BY clause and the column must not be referenced in an *expression* in the GROUP BY clause. In addition, any columns of the same table as the column for which the column mask is applied and are referenced in the definition of the column mask must be identified with a *column-name* in the GROUP BY clause. These columns must not be referenced in an *expression* in the GROUP BY clause.
- A column of a non-base tables in the select list must be specified in an aggregate function if a column mask is used to mask the column values in the final result table, and the column of a non-base table maps directly or indirectly to a column name or to an expression in a materialized table expression or view to the table where the column mask is applied.

Effect of column masks on result columns:

When column masks are enabled, they determine the values in the final result table of an outermost select list. When a column mask is enabled for a column, if the column appears in the outermost select list (either implicitly or explicitly), the column mask is applied to the column to produce the values for the final result table. If the column itself does not appear in the outermost select list, but is included in the output (for example, it appears in a materialized table expression or a view), the masked value is included in the result table of the table expression or view so that it can be used in the final result table.

The enabled column masks do not interfere with the operations of other clauses within the statement, such as the WHERE, GROUP BY, HAVING, SELECT DISTINCT, and ORDER BY clauses.

The rows that are returned in the final result table remain the same, except that the values in the result rows might be masked. As such, if a column with masked values also appears in an ORDER BY clause with a *sort-key* expression, the order is based on the original column values (the masked values in the final result table might not reflect that order). Similarly, the masked values might not reflect the uniqueness enforced by a SELECT DISTINCT. If the masked column is embedded in an expression, the result of the expression might be different because the column mask is applied to the column before the expression is evaluated. For example, a column mask on column SSN can change the result of the function COUNT(DISTINCT SSN) because the DISTINCT operation is performed on the masked values. However, if the expression in the query is the same as the expression that is used to mask the column value in the definition of the column mask, the result of the expression might remain unchanged. For example, the expression in the query is 'XXX-XX-' || SUBSTR(SSN, 8, 4) and the same

expression is used in the column mask definition. In this particular example, the expression in the query can be replaced with column SSN to avoid the same expression being evaluated twice.

If a CASE expression appears in the outermost select list, column masks are not applied to the *search-condition* of the WHEN clause.

When the definition of a column mask is applied to an SQL statement to mask column values in the final result table, the semantics of the column mask might conflict with certain SQL semantics in the statement. In these situations, the combination of the statement and the column mask might return an error.

See [“ALTER TABLE statement” on page 1232](#) for more information about the application of enabled column masks.

Null attributes of result columns:

Result columns allow null values if they are derived from one of the following:

- Any aggregate function except COUNT or COUNT_BIG
- A column that allows null values
- A view column in an outer select list that is derived from an arithmetic expression
- An arithmetic expression in an outer select list
- An arithmetic expression that allows nulls
- A scalar function or string expression that allows null values
- A host variable that has an indicator variable, an SQL parameter or variable, a global variable, or in the case of Java, a host variable or expression whose type is able to represent a Java null value
- A result of a set operator if at least one of the corresponding items in the select list is nullable

Names of result columns:

In the following cases a result column is considered a named column:

- If the AS clause is specified, the name of the result column is the name specified on the AS clause.
- If the AS clause is not specified and a column list is specified in the correlation clause, the name of the result column is the corresponding name in the correlation column list.
- If neither an AS clause nor a column list in the correlation clause is specified and the result column is derived only from a single column (without any functions or operators), the result column name is the unqualified name of that column.
- If neither an AS clause nor a column list in the correlation clause is specified and the result column is derived only from a single SQL variable, global variable, or SQL parameter (without any functions or operators), the result column name is the unqualified name of that SQL variable, global variable, or SQL parameter.

In all other cases, a result column is an unnamed column.

Names of result columns, SQL variables, and global variables are placed into the SQL descriptor area (SQLDA) when the DESCRIBE statement is executed. This allows an interactive SQL processor such as SPUFI, the command line processor, or QMF to use the column names when displaying the results. The names in the SQLDA include those specified by the AS clause.

Data types of result columns:

Each column of the result of SELECT acquires a data type from the expression from which it is derived. The following table shows the data types of result columns.

Table 163. Data types of result columns

When the expression is...	The data type of the result column is...
The name of any numeric column	The same as the data type of the column, with the same precision and scale for decimal columns.
An integer constant	INTEGER.

Table 163. Data types of result columns (continued)

When the expression is...	The data type of the result column is...
A decimal or floating-point constant	The same as the data type of the constant, with the same precision and scale for decimal constants. For floating-point constants, the data type is DOUBLE PRECISION.
A decimal floating point constant	DECFLOAT(34)
The name of any numeric host variable	The same as the data type of the variable, with the same precision and scale for decimal variables. The result is decimal if the data type of the host variable is not an SQL data type; for example, DISPLAY SIGN LEADING SEPARATE in COBOL.
An arithmetic or string expression	The same as the data type of the result, with the same precision and scale for decimal results as described in “Expressions” on page 245.
Any function	The data type of the result of the function. For a built-in function, see Chapter 4, “Built-in functions,” on page 341 to determine the data type of the result. For a user-defined function, the data type of the result is what was defined in the CREATE FUNCTION statement for the function.
The name of any string column	The same as the data type of the column, with the same length attribute.
The name of any string host variable	The same as the data type of the variable, with a length attribute equal to the length of the variable. The result is a varying-length character string if the data type of the host variable is not an SQL data type; for example, a NUL-terminated string in C.
A character string constant of length <i>n</i>	VARCHAR(<i>n</i>).
A binary string constant of length <i>n</i>	VARBINARY(<i>n</i>)
A graphic string constant of length <i>n</i>	VARGRAPHIC(<i>n</i>).
The name of a datetime column	The same as the data type of the column.
The name of a ROWID column	Row ID.
The name of a distinct type column	The same as the distinct type of the column, with the same length, precision, and scale attributes, if any.

For information about the CCSID of the result column, see [“Rules for result data types”](#) on page 166.

Related reference

[Examples of subselects](#)

You can use the various clauses of the subselect to construct queries.

unpacked-row

An *unpacked-row* specifies a row that is the result of an invocation of the UNPACK built-in function.

unpacked-row

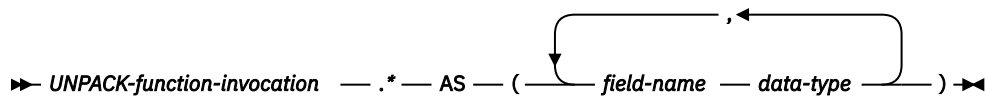

UNPACK-function-invocation

Specifies an invocation of the UNPACK built-in function. The number of specified *field-names* and *field-types* must be the same as the number of fields that are returned by the UNPACK function invocation.

field-name

Names the field that is returned from the UNPACK function. A name must not be qualified, and it does not have to be unique.

data-type

Specifies the built-in data type of the field. The specified data type, length, and CCSID must correspond to the data type, length, and CCSID of the data when the argument was initially encoded with the PACK function.

The CCSID 1208 and CCSID 1200 clauses must not be specified for *unpacked-row*.

The following table provides the supported data type mappings from the packed string data:

Data type of an encoded value in the packed string for UNPACK	Data type specified for UNPACK
SMALLINT	SMALLINT, INTEGER, BIGINT
INTEGER	INTEGER, BIGINT
BIGINT	BIGINT
decimal (<i>p,s</i>) ¹	decimal(<i>p'</i> , <i>s'</i>) if <i>s'</i> < <i>s</i> , <i>s-s'</i> digits are truncated. An error occurs if there are more than <i>p'-s'</i> significant digits.
real ² or double ³	double
CHAR(<i>n</i>) or VARCHAR(<i>n</i>)	CHAR(<i>m</i>), VARCHAR(<i>m</i>) If <i>m</i> < <i>n</i> and any of the <i>n-m</i> characters is not a blank, an error occurs. Otherwise, the <i>n-m</i> blanks are truncated. If <i>m</i> > <i>n</i> and the specified data type is CHAR, <i>m-n</i> blanks are appended.
BINARY(<i>n</i>) or VARBINARY(<i>n</i>)	BINARY(<i>m</i>), VARBINARY(<i>m</i>) If <i>m</i> < <i>n</i> , an error occurs. If <i>m</i> > <i>n</i> and the UNPACK target is BINARY, <i>m-n</i> X'00' bytes are appended.
DATE	DATE
TIME	TIME
TIMESTAMP(<i>p</i>) WITHOUT TIME ZONE	TIMESTAMP(<i>p'</i>) WITHOUT TIME ZONE. If <i>p'</i> > <i>p</i> , <i>p'-p</i> zeros are appended. If <i>p'</i> < <i>p</i> , <i>p-p'</i> digits are truncated.
TIMESTAMP(<i>p</i>) WITH TIME ZONE	TIMESTAMP(<i>p'</i>) WITH TIME ZONE. If <i>p'</i> > <i>p</i> , <i>p'-p</i> zeros are appended. If <i>p'</i> < <i>p</i> , <i>p-p'</i> digits are truncated.

Table 164. Data type mappings from packed string data (continued)

Data type of an encoded value in the packed string for UNPACK	Data type specified for UNPACK
<p>Note: The data types in lower case are defined as follows:</p> <ol style="list-style-type: none"> 1. decimal = DECIMAL(<i>p,s</i>) or NUMERIC(<i>p,s</i>) 2. real = REAL or FLOAT(<i>n</i>) where <i>n</i> is the specification for a single precision floating point 3. double = DOUBLE, DOUBLE PRECISION, FLOAT or FLOAT(<i>n</i>) where <i>n</i> is the specification for a double precision floating point <p>The synonyms for the data types, in either long or short form, are considered the same as those that are listed.</p>	

Related reference

select-clause

The SELECT clause specifies the columns of the final result table. The column values are produced by the application of the *select list* to R. The select list is a list of names and expressions specified in the SELECT clause, and R is the result of the previous operation of the subselect. For example, if SELECT, FROM, and WHERE are the only clauses specified, then R is the result of that WHERE clause.

PACK scalar function

The PACK function returns a binary string value that contains a data type array and a packed representation of each non-null *expression* argument.

UNPACK row function

The UNPACK function returns a row of values that are derived from unpacking the input binary string. It is used to unpack a string that was encoded according to the PACK function.

from-clause

The FROM clause specifies an intermediate result table.

from-clause



If only one *table-reference* is specified, the intermediate result table is simply the result of that *table-reference*. If more than one *table-reference* is specified, the intermediate result table consists of all possible combinations of the rows of the result of each specified *table-reference*.

Each row of the result is a row from the result of the first *table-reference* concatenated with a row from the result of the second *table-reference*, concatenated with a row from the result of the third *table-reference*, and so on. The number of rows in the result is the product of the number of rows in the result of each *table-reference*. Thus, if the result of any *table-reference* is empty, the result is empty.

If more than one table-reference is specified, the referenced tables and views must not include both inclusive-exclusive BUSINESS_TIME periods and inclusive-inclusive BUSINESS_TIME periods.

If *table-reference* has row access controls enforced, *table-reference* has at least one row permission: the default row permission. When there are multiple row permissions defined for a *table-reference*, a row access control search condition is derived by applying the logical OR operator to the search condition in each enabled permission. This derived search condition acts as a filter to the *table-reference* to determine the result table of the *table-reference* that is accessible to the authorization ID or role of the subselect.

If a *table-reference* contains a security label column, Db2 compares the security label of the user to the security label of each row. Results are returned according to the following rules:

- If the security label of the user dominates the security label of the row, Db2 returns the row.
- If the security label of the user does not dominate the security label of the row, Db2 does not return the data from that row, and Db2 does not generate an error report.

Related reference

Examples of subselects

You can use the various clauses of the subselect to construct queries.

table-reference

A *table-reference* specifies a result table as either a table or view, or an intermediate table.

table-reference:

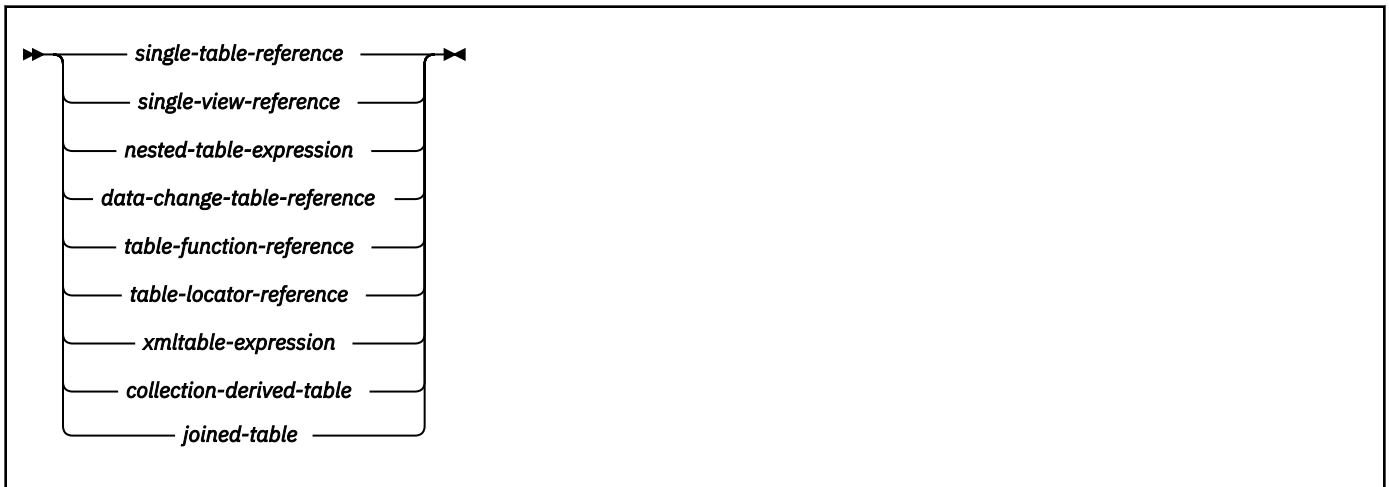

single-table-reference:

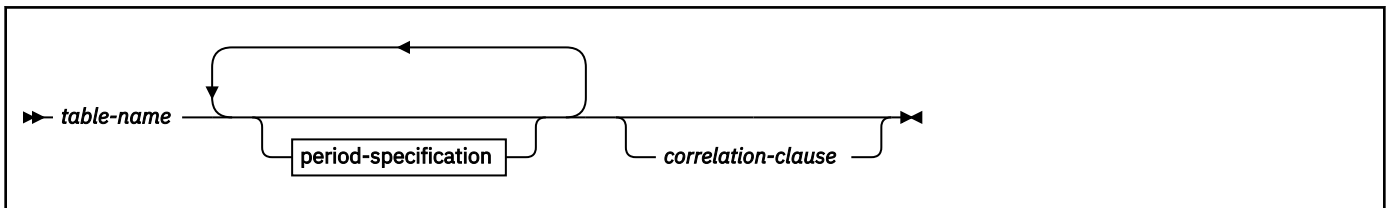

single-view-reference:

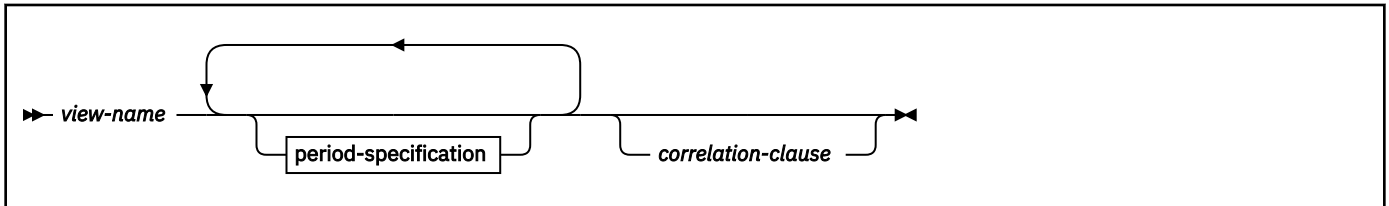

period-specification:

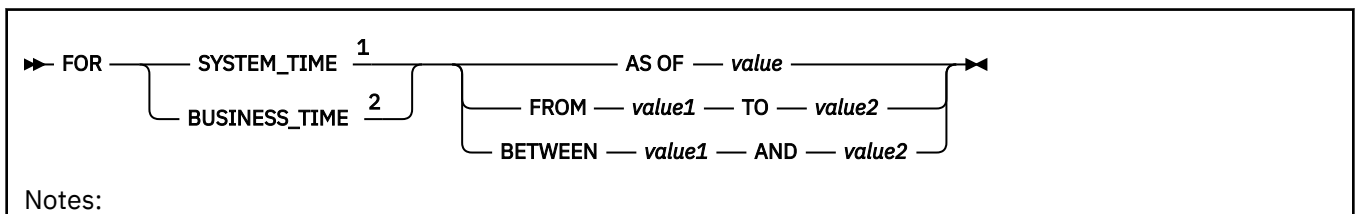

- ¹ AS OF TIMESTAMP can be specified as an alternative and is treated as if FOR SYSTEM_TIME AS OF had been specified.
- ² SYSTEM_TIME and BUSINESS_TIME cannot be specified more than one time per table.

nested-table-expression:

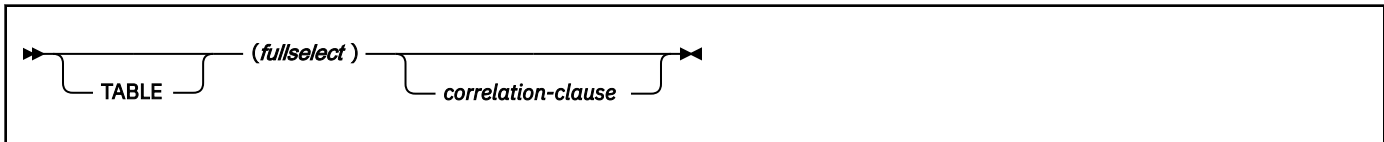

data-change-table-reference:

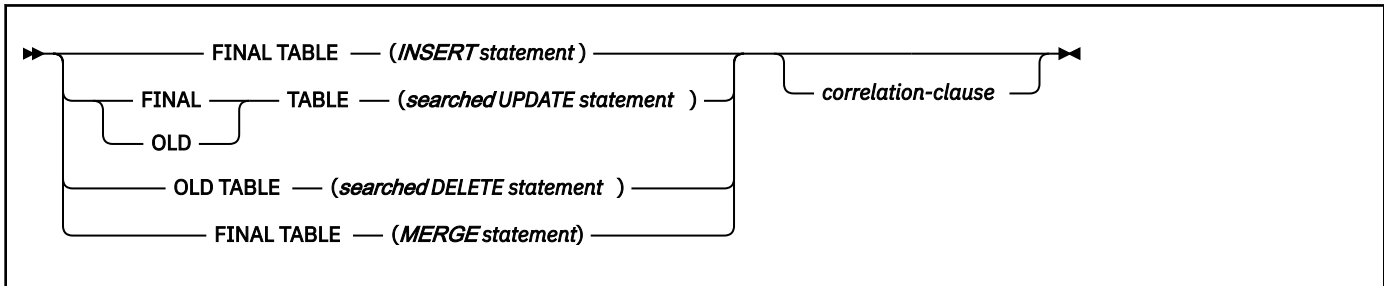

table-function-reference:

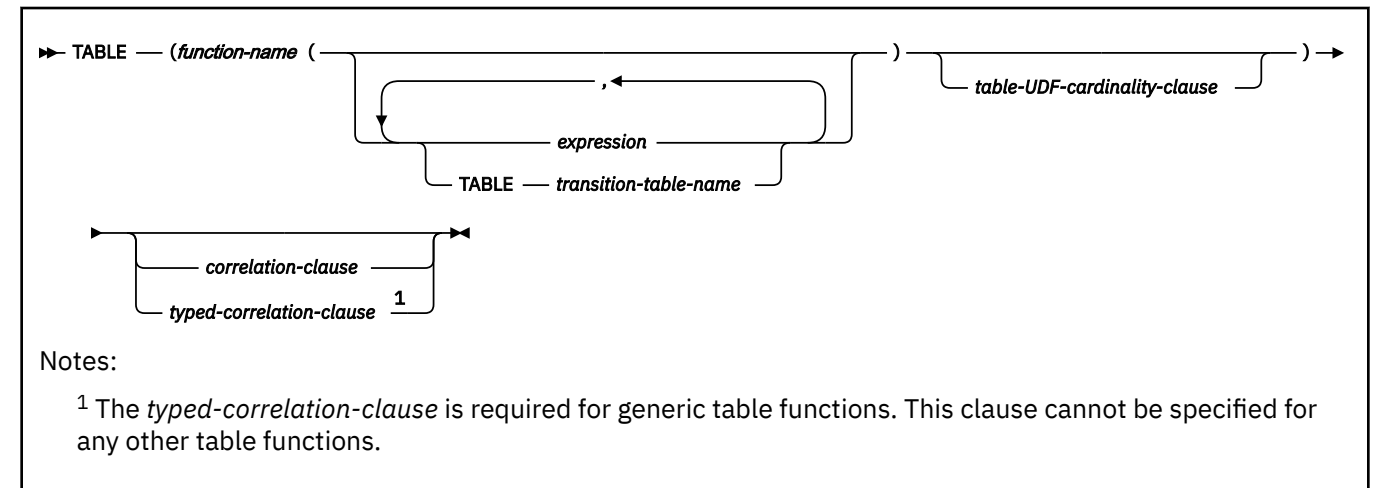

table-UDF-cardinality-clause:

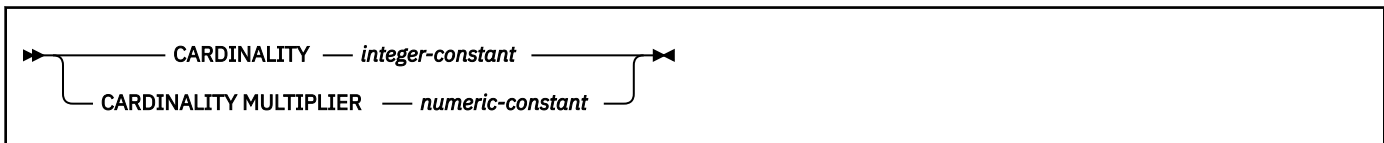
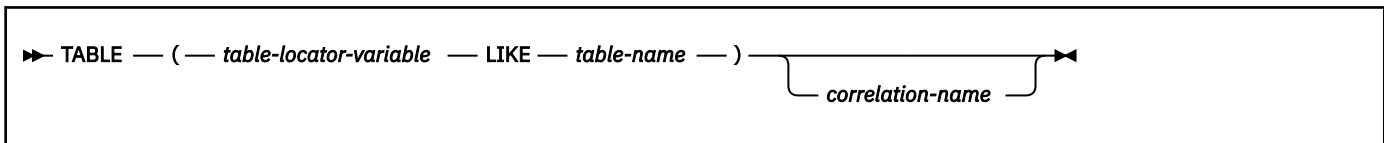
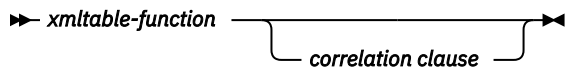

table-locator-reference:



xmltable-expression:



A *table-reference* specifies an intermediate result table.

- If a *single-table-reference* is specified and it is not an archive-enabled table or a temporal table, the intermediate result table is the specified table. If a *period-specification* is also specified, the intermediate result table consists of the rows of the temporal table where the period matches the specification.
- If a *single-table-reference* is specified and it is an archive-enabled table, the setting of the SYSIBMADM.GET_ARCHIVE global variable and the ARCHIVESENSITIVE bind option determine the contents of the intermediate result table. If the global variable is set to Y and the bind option is set to YES, the intermediate result table includes the rows in the associated archive table. Otherwise, the intermediate result table does not include rows in the associated archive table.
- If a *single-view-reference* is specified without a *period-specification*, the intermediate result table is that view. If a *period-specification* is specified, temporal table references in the view consider only the rows where the period matches the specification.
- If a *nested-table-expression* is specified, the result table is the result of the specified fullselect. The columns of the result do not need unique names, but a column with a non-unique name cannot be explicitly referenced.
- If a *data-change-table-reference* is specified, the intermediate result table is the set of rows that are directly affected by the data change statement.
- If a *table-function-reference* is specified, the intermediate result table is the set of rows that are returned by the table function.
- If a *table-locator-reference* is specified, the host variable represents the intermediate result table. The intermediate result table has the same structure as the table identified in *table-name*.
- If a *collection-derived-table* is specified, the intermediate result table is a set of rows from one or more array values. For more information, see [“collection-derived-table” on page 1031](#).
- If an *xmltable-expression* is specified, the intermediate result table is the set of rows that are returned by the [“XMLTABLE table function” on page 693 function](#).
- If a *joined-table* is specified, the intermediate result table is the result of one or more join operations. For more information, see [“joined-table” on page 1034](#).

Each *table-name* or *view-name* specified in every FROM clause of the same SQL statement must identify a table or view that exists at the same Db2 subsystem. If a FROM clause is specified in a subquery of a basic predicate, a view that includes GROUP BY or HAVING must not be identified.

A *table-reference* must not identify a table that was implicitly created for an XML column.

table-locator-variable

table-locator-variable must specify a variable with a table locator type. The only way to assign a value to a table locator is to pass the old or new transition table of a trigger to a user-defined function or stored procedure. A table locator host variable must not have a null indicator. A table locator variable must not be a parameter marker. In addition, a table locator can be used only in a manipulative SQL statement. *table-locator-reference* must not be specified in the body of a trigger.

table-name must refer to an EBCDIC table with a Unicode column if the transition table that is identified by *table-locator-variable* is for a trigger that is defined on an EBCDIC table with a Unicode column.

nested-table-expression

A *fullselect* in parentheses is called a *nested table expression*. If a nested table expression is specified, the result table is the result of that *nested-table-expression*. The columns of the result do not need unique names, but a column with a non-unique name cannot be referenced. At any time, the table consists of the rows that would result if the fullselect were executed.

table-function-reference

If a *function-name* is specified, the result table is the set of rows returned by the table function.

expression must not contain a scalar fullselect, a function, or a reference to a column.

Each *function-name*, together with the types of its arguments, must resolve to a table function that exists at the same Db2 subsystem. An algorithm called function resolution, which is described in “Function resolution” on page 239, uses the function name and the arguments to determine the exact function to use. Unless given column names in the *correlation-clause*, the column names for a table function are those specified on the RETURNS clause of the CREATE FUNCTION statement. This is analogous to the column names of a table, which are defined in the CREATE TABLE statement.

If a column mask is used to mask the column values in the final result table, and if the result of the table function is used to derive the final result table, the column mask cannot be applied to a column that is specified in the argument of the table function.

table-UDF-cardinality-clause

The *table-UDF-cardinality-clause* can be specified to each user-defined table function reference within the table spec of the FROM clause in a subselect. This option indicates the expected number of rows to be returned only for the SELECT statement that contains it.

CARDINALITY *integer-constant* specifies an estimate of the expected number of rows returned by the reference to the user-defined function. The value of *integer-constant* must range 0–2147483647.

The value set in the CARDINALITY field of SYSIBM.SYSROUTINES for the table function name is used as the reference cardinality value. The product of the specified CARDINALITY MULTIPLIER *numeric-constant* and the reference cardinality value are used by Db2 as the expected number of rows returned by the table function reference.

In this case, the *numeric-constant* can be in the integer, decimal, or floating-point format. The value must be greater than or equal to zero. If the decimal number notation is used, the number of digits can be up to 31. An integer value is treated as a decimal number with no fraction. The maximum value allowed for a floating-point number is about 7.237E + 75. If no value has been set in the CARDINALITY field of SYSIBM.SYSROUTINES, its default value is used as the reference cardinality value. If zero is specified or the computed cardinality is less than 1, Db2 assumes that the cardinality of the reference to the user-defined table function is 1.

Only a numeric constant can follow the keyword CARDINALITY or CARDINALITY MULTIPLIER. No host variable or parameter marker is allowed in a cardinality option. Specifying a cardinality option in a table function reference does not change the corresponding CARDINALITY field in SYSIBM.SYSROUTINES. The CARDINALITY field value in SYSIBM.SYSROUTINES can be initialized by the CARDINALITY option in the CREATE FUNCTION (external table) statement when a user-defined table function is created. It can be changed by the CARDINALITY option in the ALTER FUNCTION statement or by a direct update operation to SYSIBM.SYSROUTINES.

data-change-table-reference

A *data-change-table-reference* clause specifies an intermediate result table. This table is based on the rows that are directly changed by the SQL data change statement that is included in the clause. A *data-change-table-reference* can only be specified as the only *table-reference* in the FROM clause of the outer fullselect that is used in a select-statement and that fullselect must be in a subselect, or a SELECT INTO statement. A *data-change-table-reference* in a SELECT statement of a cursor makes the cursor read only. The target table or view of the SQL data change statement is a table or view that is reference in the query. The privileges that are held by the authorization ID of the statement must include the SELECT privilege on that target table or view. The encoding scheme of the result table of the SELECT must be the same as the encoding scheme of the target table or view of the *data-change-table-reference*.

If row access control is enforced for the target of the data change statement, the rows in the intermediate result table already satisfy the rules that are specified in the enabled row permissions. If column access control is enforced for the target of the data change statement, the enabled column masks are applied to the outermost select list. For more information, see “select-clause” on page 1010. If an INCLUDE clause is specified as part of the SQL data change statement, and these

additional columns appear in the outermost select list, the column values must not be derived from columns for which column masks are defined.

Expressions in the select list of a view in a table reference can only be selected if OLD TABLE is specified or if the expression does not include any of the following objects:

- a function that is defined to read or modify SQL data
- a function that is defined as not deterministic or has an external action
- a NEXT VALUE expression for a sequence

FINAL TABLE

Specifies that the rows of the intermediate result table represent the set of rows that are changed by the SQL data change statement as they appear at the completion of the SQL data change statement. If there are AFTER triggers that result in further operations on the table that is the target of the SQL data change statement, an error is returned. If the target of the SQL data change statement is a view that is defined with an INSTEAD OF trigger for the type of data change, an error is returned.

OLD TABLE

The rows of the intermediate result table represent the set of affected rows as they exist prior to the application of the SQL data change statement.

INSERT statement

Specifies an INSERT statement as described in [“INSERT statement” on page 1996](#). A fullselect in the INSERT statement cannot contain correlated references to columns that are outside of the fullselect of the INSERT statement. The target of the INSERT statement must be a base table, a view that is defined with the WITH CASCADED CHECK clause, or a view where the view definition has no WHERE clause. If there are input variables elsewhere in the fullselect, the INSERT statement cannot be a multiple row not atomic insert, or a multiple row atomic insert that specifies the USING DESCRIPTOR clause.

MERGE statement

Specifies a MERGE statement as described in [“MERGE statement” on page 2019](#). The MERGE statement must conform to the following rules:

- The target of the MERGE statement must be a base table, a view that is defined with the WITH CASCADED CHECK clause, or a view where the view definition has no WHERE clause.
- The target table or view of the MERGE statement must not have a column with a ROWID data type. Additionally, when NOT ATOMIC CONTINUE ON SQLEXCEPTION is specified, the target table or view of the MERGE statement must not have a column with a LOB or XML data type.
- If *table-reference* is specified in the MERGE statement, it must not contain correlated references to columns that are outside of the table reference in the MERGE statement.
- If *table-reference* is specified in the MERGE statement, AFTER triggers that result in further operations on the target table must not exist.
- When NOT ATOMIC CONTINUE ON SQLEXCEPTION is specified in the MERGE statement, or the NOT ATOMIC CONTINUE ON SQLEXCEPTION clause is not specified, and *source-values* (VALUES) is specified, the MERGE statement must not include a delete operation.

searched UPDATE statement

Specifies a searched UPDATE statement as described in [“UPDATE statement” on page 2178](#). A WHERE clause or a SET clause in the UPDATE statement cannot contain correlated references to columns that are outside of the UPDATE statement. The target of the UPDATE statement must be a base table, a symmetric view, or a view where the view definition has no WHERE clause.

If the searched UPDATE statement is used in the SELECT statement and the UPDATE statement references a view, the view must be defined using the WITH CASCADED CHECK OPTION clause.

A searched UPDATE statement in a SELECT statement will not clear the AREO* status of a table.

AFTER triggers that result in further operations on the target table cannot exist on the target table.

searched DELETE statement

Specifies a searched DELETE statement as described in [“DELETE statement”](#) on page 1853. A WHERE clause in the DELETE statement cannot contain correlated references to columns that are outside of the DELETE statement. The target of the DELETE statement must be a base table, a symmetric view, or a view where the view definition has no WHERE clause.

If the searched DELETE statement is used in the SELECT statement and the DELETE statement references a view, the view must be defined using the WITH CASCADED CHECK OPTION clause.

AFTER triggers that result in further operations on the target table cannot exist on the target table.

The content of the intermediate result table for a table reference that contains an SQL data change statement is determined when the cursor is opened. The intermediate result table includes a column for each of the columns of the target table (including implicitly hidden columns) or view. All of the columns of the target table or view of an SQL data change statement are accessible by using the names of the columns from the target table or view unless the columns are renamed by using the correlation clause. If an INCLUDE clause is specified as part of the SQL data change statement, the intermediate result table will contain these additional columns.

correlation-clause

Each *correlation-name* in a *correlation-clause* defines a designator for the immediately preceding result table, which can be used to qualify references to the columns of the table. For more information, see [“correlation-clause”](#) on page 1028.

The exposed names of all table references in the FROM clause should be unique. An *exposed name* is considered to be any of the following names:

- A *correlation-name*
- A *table-name* that is not followed by a *correlation-name*
- A *view-name* that is not followed by a *correlation-name*
- A *function-name* that is not followed by a *correlation-name*
- The table name that is specified after LIKE when a *table-locator* is not followed by a *correlation-name*
- The target table or view name for a *data-change-table-reference* that is not followed by a *correlation-name*
- An *alias-name* that is not followed by a *correlation-name*
- A *synonym-name* that is not followed by a *correlation-name*

If a *correlation-clause* clause does not follow an *xmltable-expression* reference, a *nested-table-expression* reference, or a *collection-derived-table-reference*, there is no exposed name for that table reference.

Any qualified reference to a column must use the exposed name. If the same name is specified twice, at least one specification should be followed by a *correlation-name*. The *correlation-name* is used to qualify references to the columns of the table or view. When a *correlation-name* is specified, column names can also be specified to give names to the columns of the table reference. If the *correlation-clause* does not include column names, the exposed column names are determined as follows:

- Column names of the referenced table or view when the *table-reference* is *table-name*, *view-name*, *alias-name*, or *synonym-name*
- Column names specified in the RETURNS clause of the CREATE FUNCTION statement when the *table-reference* is a *function-name* reference
- Column names of the table referenced after LIKE when the *table-reference* is a *table-locator*
- Column names specified in the COLUMNS clause of the *xmltable-expression* when the *table-reference* is an *xmltable-expression*
- Column names returned by the fullselect when the *table-reference* is a *nested-table-expression*

- Column names from the target table of the data change statement, along with any defined INCLUDE columns, when the *table-reference* is a *data-change-table-reference*

Otherwise, there are no exposed names for the columns of that table reference.

typed-correlation-clause

A *typed-correlation-clause* defines the appearance and contents of the table generated by a generic table function. This clause must be specified when the *table-function-reference* is a generic table function and cannot be specified for any other table reference. For more information, see [“typed-correlation-clause” on page 1029](#).

xmltable-expression

Specifies an invocation of the built-in XMLTABLE function. For more information, see [“XMLTABLE table function” on page 693](#).

If a column mask is used to mask the column values in the final result table, and if the result of the XMLTABLE function is used to derive the final result table, the column mask cannot be applied to a column that is specified in the PASSING clause of the XMLTABLE function.

collection-derived-table

A *collection-derived-table* is used to convert the elements of one or more arrays into column values in separate rows of an intermediate result table, as explained in [“collection-derived-table” on page 1031](#).

joined-table

If a *joined-table* is specified, the result table is the result of one or more join operations as explained in [“joined-table” on page 1034](#).

period-specification

Specifies that a period specification applies to the *table-reference*. The same period name (SYSTEM_TIME or BUSINESS_TIME) must not be specified more than one time for the same table. If the table reference specifies a view, the definition of that view must not reference a user-defined function.

The rows of the table reference are derived by application of the specified period specification. The intermediate result table does not include rows in the associated history table that were added for the ON DELETE ADD EXTRA ROW attribute in the system-period temporal table definition.

Note: History tables are intended to include only rows that Db2 stores to record the history of the associated system-period temporal table. However, if the history table contains other rows with the same value in the two columns that correspond to the row-begin and row-end columns in the system-period temporal table, the intermediate result table might include these rows. These rows might be included in the following cases:

- The system-period temporal table is defined with the ON DELETE ADD EXTRA ROW attribute, the table contains a DATA CHANGE OPERATION column, and the value of the corresponding column in the history table is not 'D'.
- The system-period temporal table is not defined with the ON DELETE ADD EXTRA ROW attribute.

The rows of a view reference are derived by application of the specified period specifications to all of the temporal tables that are accessed when computing the result table of the view. If the view does not access any temporal tables, the period specification has no effect on the result table of the view.

If the table is a bitemporal table and a *period-specification* is not specified for both SYSTEM_TIME or BUSINESS_TIME, the table reference includes all current rows of the table and does not include any historical rows of the table.

If the CURRENT TEMPORAL SYSTEM_TIME special register is set to a value other than the null value, a *period-specification* for a table or view cannot reference SYSTEM_TIME. This restriction applies even if the view body does not reference a system-period temporal table. The exception is if the value in effect for the SYSTIMESENSITIVE bind option is NO. In this case, the *period-specification* can reference SYSTEM_TIME.

If the CURRENT TEMPORAL BUSINESS_TIME special register is set to a value other than the null value, a *period-specification* for a table or view cannot reference BUSINESS_TIME. This restriction

applies even if the view body does not reference an application-period temporal table. The exception is if the value in effect for the BUSTIMESENSITIVE bind option is NO. In this case, the *period-specification* can reference BUSINESS_TIME.

For more information, see:

[“CURRENT TEMPORAL BUSINESS_TIME special register” on page 208](#)

[“CURRENT TEMPORAL SYSTEM_TIME special register” on page 210](#)

FOR SYSTEM_TIME

Specifies that the SYSTEM_TIME period is used for the *period-specification*. The table reference must be a system-period temporal table or a view.

Do not specify FOR SYSTEM_TIME if the value of the CURRENT TEMPORAL SYSTEM_TIME special register is not NULL and the SYSTIMESENSITIVE bind option is set to YES .

FOR BUSINESS_TIME

Specifies that the BUSINESS_TIME period is used for the *period-specification*. The table reference must be an application-period temporal table or a view.

Do not specify FOR BUSINESS_TIME if the value of the CURRENT TEMPORAL BUSINESS_TIME special register is not NULL and the BUSTIMESENSITIVE bind option is set to YES .

AS OF value

Specifies that the *table-reference* includes rows that exist at the time that is specified by *value* as follows:

- For an inclusive-exclusive period, a row is included if the begin value for the specified period is less than or equal to *value*, and the end value for the period is greater than *value*. If *value* is the null value, the table reference is an empty table.
- For an inclusive-inclusive period, a row is included if the begin value for the specified period is less than or equal to *value*, and the end value for the period is greater than or equal to *value*. If *value* is the null value, the table reference is an empty table.

value

Specifies an expression that returns a value of a built-in data type. The result of the expression must be comparable to the data type of the columns of the specified period according to the comparison rules specified in [“Assignment and comparison” on page 143](#).

The expression must not have a timestamp precision that is greater than the precision of the columns for the period.

If the begin and end columns of the period are defined as TIMESTAMP WITHOUT TIME ZONE, the expression must not return a value of a timestamp with a time zone.

The expression can contain any of the following supported operands:

- A constant
- A special register
- A variable
- An array element specification
- A built-in scalar function whose arguments are supported operands
- A CAST specification where the cast operand is a supported operand
- An expression that uses arithmetic operators and operands

A period specification for a view must not contain an untyped parameter marker.

FROM value1 TO value2

Specifies that the *table-reference* includes rows that exist for the period that is specified from *value1* up to *value2*.

- For an inclusive-exclusive period, a row is included in the *table-reference* if the start value for the period in the row is less than *value2*, and the end value for the period in the row is greater

than *value1*. The *table-reference* contains zero rows if *value1* is greater than or equal to *value2*. If *value1* or *value2* is the null value, the table reference is an empty table.

- For an inclusive-inclusive period, a row is included in the *table-reference* if the start value for the period in the row is less than *value2*, and the end value for the period in the row is greater than or equal to *value1*. The *table-reference* contains zero rows if *value1* is greater than or equal to *value2*. If *value1* or *value2* is the null value, the table reference is an empty table.

value1 or value2

Specifies an expression that returns a value of a built-in data type. The result of the expression must be comparable to the data type of the columns of the specified period according to the comparison rules specified in [“Assignment and comparison”](#) on page 143.

The expression must not have a timestamp precision that is greater than the precision of the columns for the period.

If the begin and end columns of the period are defined as `TIMESTAMP WITHOUT TIME ZONE`, the expression must not return a value of a timestamp with a time zone.

The expression can contain any of the following supported operands:

- A constant
- A special register
- A variable
- An array element specification
- A built-in scalar function whose arguments are supported operands
- A `CAST` specification where the cast operand is a supported operand
- An expression that uses arithmetic operators and operands

A period specification for a view must not contain an untyped parameter marker.

BETWEEN value1 AND value2

Specifies that the *table-reference* includes rows in which the specified period overlaps at any point in time between *value1* and *value2*.

- For an inclusive-exclusive period, a row is included in the *table-reference* if the start value for the period in the row is less than or equal to *value2* and the end value for the period in the row is greater than *value1*. The *table-reference* contains zero rows if *value1* is greater than *value2*. If *value1* = *value2*, the expression is equivalent to `AS OF value1`. If *value1* or *value2* is the null value, the *table-reference* is an empty table.
- For an inclusive-inclusive period, a row is included in the *table-reference* if the start value for the period in the row is less than or equal to *value2* and the end value for the period in the row is greater than or equal to *value1*. The *table-reference* contains zero rows if *value1* is greater than *value2*. If *value1* = *value2*, the expression is equivalent to `AS OF value1`. If *value1* or *value2* is the null value, the *table-reference* is an empty table.

value1 or value2

Specifies an expression that returns a value of a built-in data type. The result of the expression must be comparable to the data type of the columns of the specified period according to the comparison rules specified in [“Assignment and comparison”](#) on page 143.

The expression must not have a timestamp precision that is greater than the precision of the columns for the period.

If the begin and end columns of the period are defined as `TIMESTAMP WITHOUT TIME ZONE`, the expression must not return a value of a timestamp with a time zone.

The expression can contain any of the following supported operands:

- A constant
- A special register
- A variable

- An array element specification
- A built-in scalar function whose arguments are supported operands
- A CAST specification where the cast operand is a supported operand
- An expression that uses arithmetic operators and operands

A period specification for a view must not contain an untyped parameter marker.

Notes

Correlated references in *table-reference*:

In general, nested table expressions and table functions can be specified in any FROM clause. Columns from the nested table expressions and table functions can be referenced in the select list and in the rest of the fullselect using the correlation name. The scope of this correlation name is the same as correlation names for other table or view names in the FROM clause. The basic rule that applies for both these cases is that the correlated reference must be from a *table-reference* at a higher level in the hierarchy of subqueries.

Nested table expressions can be used in place of a view to avoid creating a view when general use of the view is not required. They can also be used when the result table is based on host variables.

For table functions, an additional capability exists. A table function can contain one or more correlated references to other tables in the same FROM clause if the referenced tables precede the reference in the left-to-right order of the tables in the FROM clause. The same capability exists for nested table expressions if the optional keyword TABLE is specified; otherwise, only references to higher levels in the hierarchy of subqueries is allowed.

A nested table expression or table function that contains correlated references to other tables in the same FROM clause:

- Cannot participate in a FULL OUTER JOIN or a RIGHT OUTER JOIN
- Can participate in LEFT OUTER JOIN or an INNER JOIN if the referenced tables precede the reference in the left-to-right order of the tables in the FROM clause

The following table shows some examples of valid and invalid correlated references. TABF1 and TABF2 represent table functions.

Subselect	Valid	Reason
<pre>SELECT T.C1, Z.C5 FROM TABLE(TABF1(T.C2)) AS Z, T WHERE T.C3 = Z.C4;</pre>	No	T.C2 cannot be resolved because T does not precede TABF1 in FROM
<pre>SELECT T.C1, Z.C5 FROM T, TABLE(TABF1(T.C2)) AS Z WHERE T.C3 = Z.C4;</pre>	Yes	T precedes TABF1 in FROM, making T.C2 known
<pre>SELECT A.C1, B.C5 FROM TABLE(TABF2(B.C2)) AS A, TABLE(TABF1(A.C6)) AS B WHERE A.C3 = B.C4;</pre>	No	B in B.C2 cannot be resolved because the table function that would resolve it, TABF1, follows its reference in TABF2 in FROM
<pre>SELECT D.DEPTNO, D.DEPTNAME, EMPINFO.AVGSAL, EMPINFO.EMPCOUNT FROM DEPT D, (SELECT AVG(E.SALARY) AS AVGSAL, COUNT(*) AS EMPCOUNT FROM EMP E WHERE E.WORKDEPT = D.DEPTNO) AS EMPINFO;</pre>	No	DEPT precedes nested table expression, but keyword TABLE is not specified, making D.DEPTNO unknown

Table 165. Examples of correlated references (continued)

Subselect	Valid	Reason
<pre>SELECT D.DEPTNO, D.DEPTNAME, EMPINFO.AVGSAL, EMPINFO.EMPCOUNT FROM DEPT D, TABLE (SELECT AVG(E.SALARY) AS AVGSAL, COUNT(*) AS EMPCOUNT FROM EMP E WHERE E.WORKDEPT = D.DEPTNO) AS EMPINFO;</pre>	Yes	DEPT precedes nested table expression and keyword TABLE is specified, making D.DEPTNO known

Affects of special registers:

The setting of the CURRENT TEMPORAL BUSINESS_TIME and CURRENT TEMPORAL SYSTEM_TIME special registers might affect the result of a query, as described in the following situations:

- Assume the following conditions:
 - A table reference is an application-period temporal table.
 - The columns of the BUSINESS_TIME period are defined as TIMESTAMP(6).
 - The CURRENT TEMPORAL BUSINESS_TIME special register is set to a non-null value.

In this case, a query is executed as if it contained the following specification:

```
FOR BUSINESS_TIME AS OF CURRENT TEMPORAL BUSINESS_TIME
```

- Assume the following conditions:
 - A table reference is an application-period temporal table.
 - The columns of the BUSINESS_TIME period are defined as DATE.
 - The CURRENT TEMPORAL BUSINESS_TIME special register is set to a non-null value.

In this case, a query is executed as if it contained the following specification:

```
FOR BUSINESS_TIME AS OF CAST(CURRENT TEMPORAL BUSINESS_TIME AS DATE)
```

- If the CURRENT TEMPORAL SYSTEM_TIME special register is set to a non-null value, a query is executed as if it contained the following specification:

```
FOR SYSTEM_TIME AS OF CURRENT TEMPORAL SYSTEM_TIME
```

Related reference

Examples of subselects

You can use the various clauses of the subselect to construct queries.

correlation-clause

Each *correlation-name* in a *correlation-clause* defines a designator for the immediately preceding result table, which can be used to qualify references to the columns of the table.

correlation-clause:

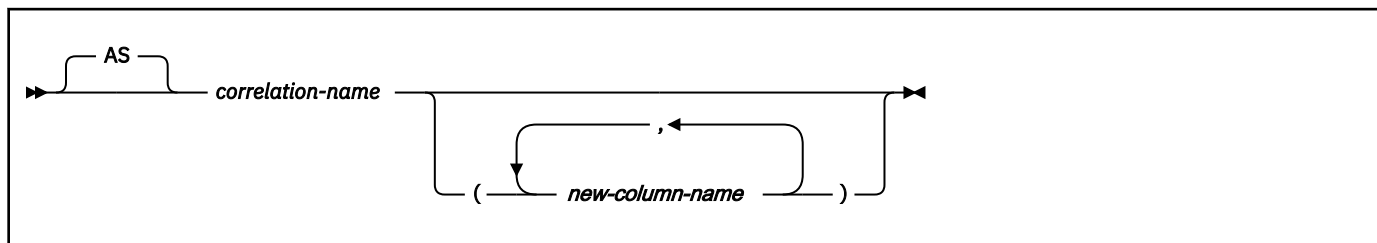

The preceding result table is one of the following objects:

- A table

- A view
- A nested table expression
- A table function
- A data-change table reference
- A collection-derived table

new-column-name is an SQL identifier of 128 UTF-8 bytes or less. Using *new-column-name* to list and rename the columns is optional. A correlation name must be specified for nested table expressions and references to table functions.

If *correlation-name* is not specified for a data-change table reference, the correlation name is the name of the target table or view of the SQL data change statement. Otherwise, the correlation name is *correlation-name*.

If a *new-column-name* list is specified in *correlation-clause*, the number of names must be the same as the number of columns in the corresponding object. Each name must be unique and unqualified. If columns are added to an underlying table of a *table-reference*, the number of columns in the result of the *table-reference* no longer matches the number of names in its *correlation-clause*. Therefore, when a rebind of a package containing the query in question is attempted, Db2 returns an error and the rebind fails. At that point, change the *correlation-clause* of the embedded SQL statement in the application program so that the number of names matches the number of columns. Then prepare the modified program again.

An exposed name is a *correlation-name* or a *table-name* or view name that is not followed by a *correlation-name*. The exposed names in a FROM clause must be unique. Any qualified reference to a column for a table, view, nested table expression, table function, data-change table reference, or collection-derived table must use the exposed name.

If the same table name or view name is specified twice, at least one specification must be followed by a *correlation-name*. The *correlation-name* is used to qualify references to the columns of the table or view.

When a *correlation-name* is specified, column names can also be specified to give names to the columns of the *table-name*, *view-name*, *nested-table-expression*, *table-function*, *data-change-table-reference*, or *collection-derived-table*. If a column list is specified, there must be a name in the column list for each column in the table or view and for each result column in the *table-function*, *data-change-table-reference*, or *collection-derived-table*.

For more information, see [“Correlation names”](#) on page 220.

In general, *nested-table-expression*, *table-function*, *data-change-table-reference*, or *collection-derived-table* can be specified in any FROM clause. Columns from the *nested-table-expression*, *table-function*, *data-change-table-reference*, or *collection-derived-table* can be referenced in the SELECT list and in the rest of the subselect using a correlation name. The scope of this correlation name is the same as correlation names for other table or view names in the FROM clause.

Related reference

[SET assignment-statement statement](#)

The SET *assignment-statement* statement assigns values to variables and array elements.

[table-reference](#)

A *table-reference* specifies a result table as either a table or view, or an intermediate table.

typed-correlation-clause

A *typed-correlation-clause* defines the appearance and contents of the table generated by a generic table function.

typed-correlation-clause:

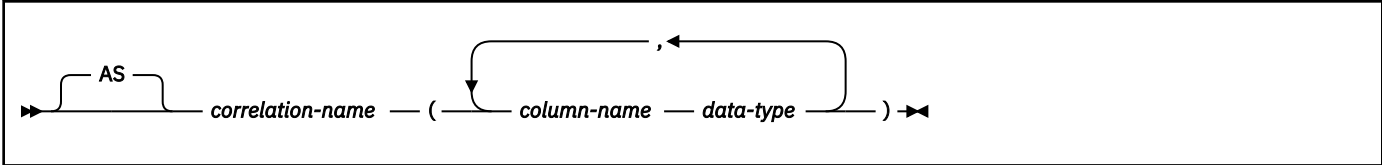

data-type:

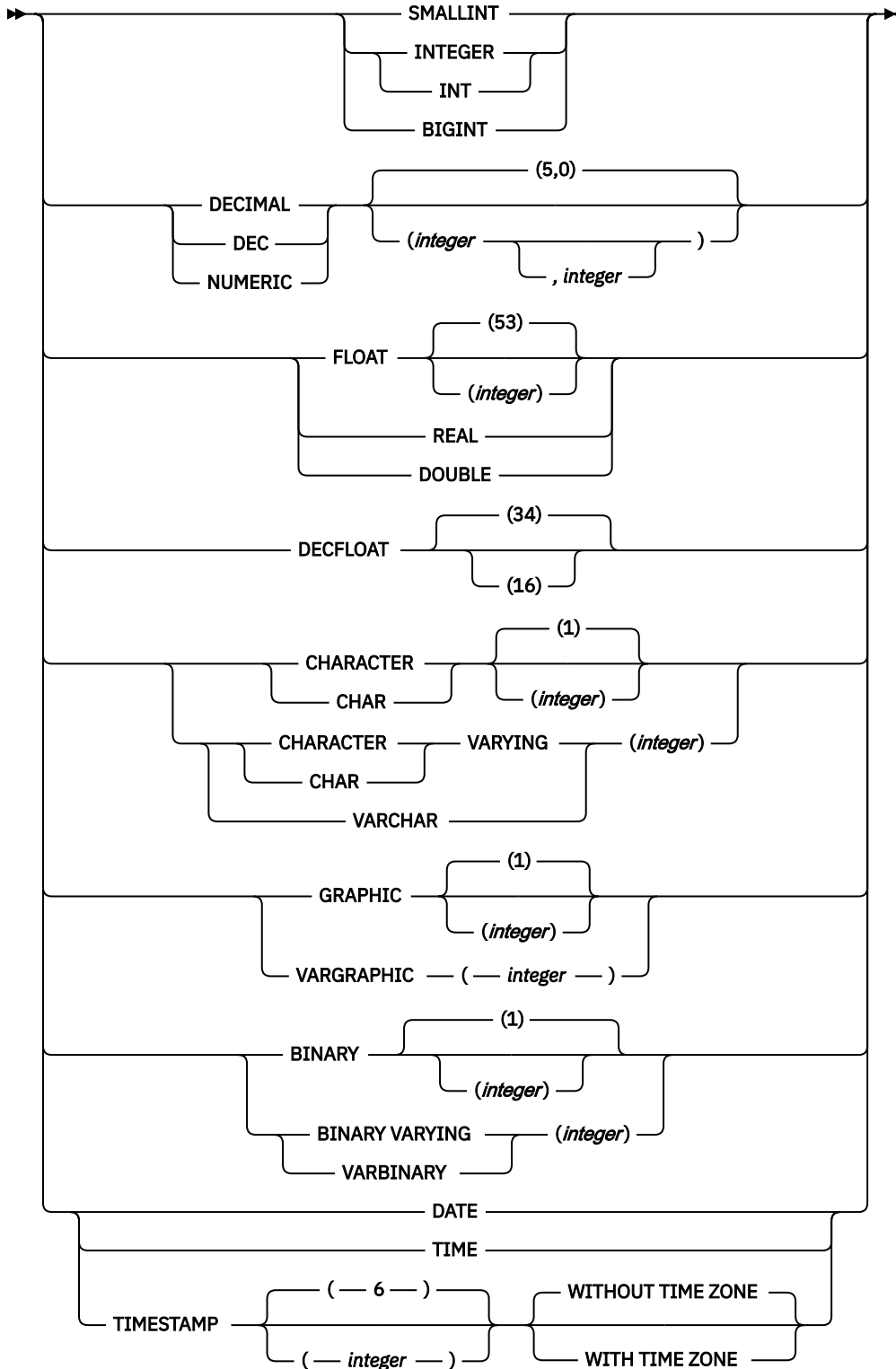

typed-correlation-clause

The *typed-correlation-clause* defines the appearance and contents of the table that is generated by a generic table function. *typed-correlation-clause* must be specified when the *table-function-reference* is a generic table function and cannot be specified for any other table reference.

The maximum number of columns specified in the *typed-correlation-clause* is 750, an error is returned if the number of specified columns exceeds the limit.

An error is returned if duplicate column names are specified in a *typed-correlation-clause*.

An error is returned if the data type that is specified for a column name is not one of the supported data types for a generic table function.

Related reference

CREATE FUNCTION statement (external table function)

This CREATE FUNCTION statement registers a user-defined external table function with a database server. A user-defined external table function can be used in the FROM clause of a subselect. It returns a table to the subselect by returning one row at a time each time it is invoked.

collection-derived-table

A *collection-derived table* is used to convert the elements of one or more arrays into column values in separate rows of an intermediate result table.

collection-derived-table:

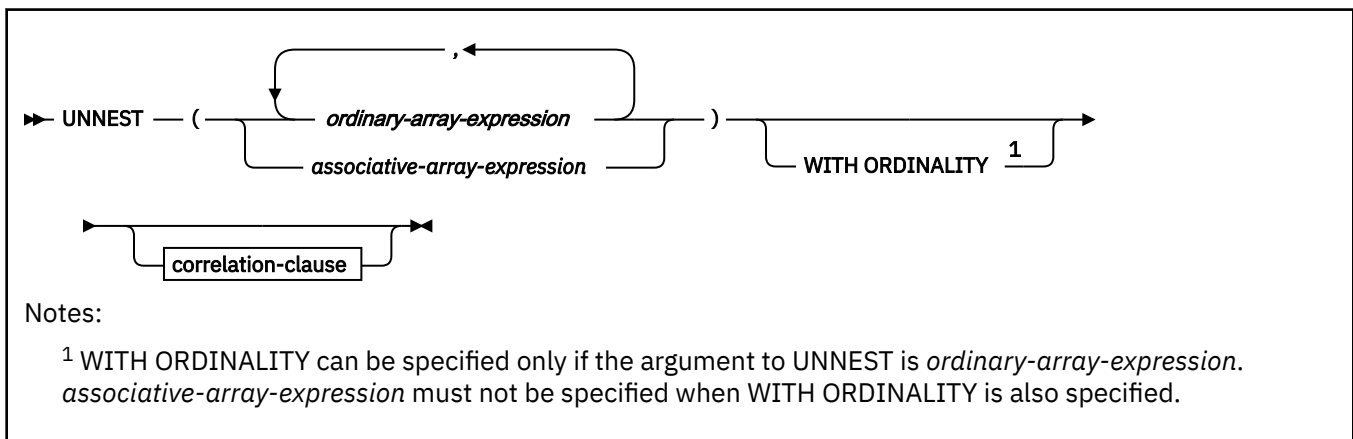

WITH ORDINALITY

Specifies that an extra column of data type INTEGER is returned as the last column in the result table. This column contains the position of the element in the array.

correlation-clause

Specifies the correlation name that is to be used as a table designator for the result table of the collection derived table, and a list of column names for the result table. The correlation name can be used to qualify references to the columns of the result table.

The result columns can be referenced in the SELECT list, and in the rest of the subselect by using the names that are specified for the columns in the correlation clause.

A collection-derived table can be specified as a table reference in a FROM clause, in a context where arrays are supported.

The intermediate result table is derived as follows:

- If a single expression that returns an ordinary array is specified, the intermediate result table is a single-column table with a column data type that matches the array element data type.
- If multiple expressions that return an ordinary array are specified:
 - The first array provides the first column in the result table, the second array provides the second column, and so on.

- The data type of each column matches the data type of the array elements of the corresponding array argument.
- If the cardinalities of the arrays are not identical, the cardinality of the resulting table is the same as the array with the largest cardinality.
- The column values in the table are set to the null value for all rows whose array index value is greater than the cardinality of the corresponding array. In other words, if each array is viewed as a table with two columns, one for the array indexes and one for the data, UNNEST performs an outer join among the arrays, using equality on the array indexes as a join predicate.
- If a single *associative-array-expression* or an *array-function-invocation* that returns an associative array is specified:
 - The intermediate result table is a table with two columns, where the first column data type matches the array index data type, and the second column data type matches the array element data type.
 - The first column contains the indexes of the elements in the array.
 - The second column contains the elements in the array.
 - The columns can be referenced in the SELECT list and the in rest of the subselect by using the names that are specified for the columns in the *correlation-clause*.
- If all arguments are null arrays, the result is an empty table.

The intermediate result table that is produced by an invocation of UNNEST must not result in more than 750 columns.

An *array-function-invocation* is a function invocation that resolves to a function that returns an ordinary or an associative array type. An *array-function-invocation* must not include a reference to a column of a common table expression.

ordinary-array-expression

Specifies one of the following items:

- An SQL variable
- An SQL parameter
- A global variable of an ordinary array type
- An *array-function-invocation*
- A CAST specification of a parameter marker to an ordinary array type

associative-array-expression

Specifies one of the following items:

- An SQL variable
- An SQL parameter
- A global variable of an associative array type
- An *array-function-invocation*
- A CAST specification of a parameter marker to an associative array type

Names for the result columns that are produced by an UNNEST specification can be provided as part of the *correlation-clause* of the *collection-derived-table* clause.

Example 1: Suppose that PHONENUMBERS is a user-defined array type that is defined as an ordinary array. RECENT_CALLS is an array variable of the PHONENUMBERS type. RECENT_CALLS contains the following phone numbers:

- 9055553907
- 4165554213
- 4085553678

The following SELECT statement uses UNNEST to retrieve the list of phone numbers from the array:

```
SELECT T.ID, T.NUM
FROM UNNEST(RECENT_CALLS) WITH ORDINALITY AS T(NUM, ID);
```

The WITH ORDINALITY clause indicates that the result table is to include an additional column that reflects the ordinal position of each array element in the array. The additional column is the last column of the result table from the UNNEST operation. The correlation clause that follows the WITH ORDINALITY clause specifies that the additional column is named ID, and the array element column is named NUM. These column names can be explicitly referenced in the SELECT list of the query. The SELECT list in this example reorders the columns from the result of UNNEST. The result table looks like this:

ID	NUM
1	9055553907
2	4165554213
3	4085553678

In the SELECT statement, the columns that result from the UNNEST operation have been reordered in the SELECT list, so that the column that reflects the position of each array element is the first column of the final result table.

Example 2: Suppose that PERSONAL_PHONENUMBERS is a user-defined array type that is defined as an associative array. PHONELIST is an array variable of the PERSONAL_PHONENUMBERS type. Values have been assigned to the elements of PHONELIST with the following statements:

```
SET PHONELIST['Home'] = '4443051234';
SET PHONELIST['Work'] = '4443052345';
SET PHONELIST['Cell'] = '4447893456';
```

The following SELECT statement is executed:

```
SELECT T.ID, T.PHONE
FROM UNNEST(PHONELIST) AS T(ID, PHONE);
```

The result table looks like this, although the order of rows might differ:

ID	PHONE
Cell	4447893456
Home	4443051234
Work	4443052345

Example 3: Suppose that PHONES and IDS are two SQL variables with array values of the same cardinality. The following SQL statement converts the array contents into a table with three columns (one for each array and one for the position), and one row for each array element.

The following SELECT statement is executed:

```
SELECT T.PHONE, T.ID, T.INDEX FROM UNNEST(PHONES, IDS)
WITH ORDINALITY AS T(PHONE, ID, INDEX)
ORDER BY T.INDEX;
```

Related reference

[SET assignment-statement statement](#)

The SET *assignment-statement* statement assigns values to variables and array elements.

[table-reference](#)

A *table-reference* specifies a result table as either a table or view, or an intermediate table.

joined-table

A *joined-table* specifies an intermediate result table that is the result of either an inner join, an outer join, or a cross join. The table is derived by applying one of the join operators: INNER, LEFT OUTER, RIGHT OUTER, FULL OUTER, or CROSS to its operands.

joined-table

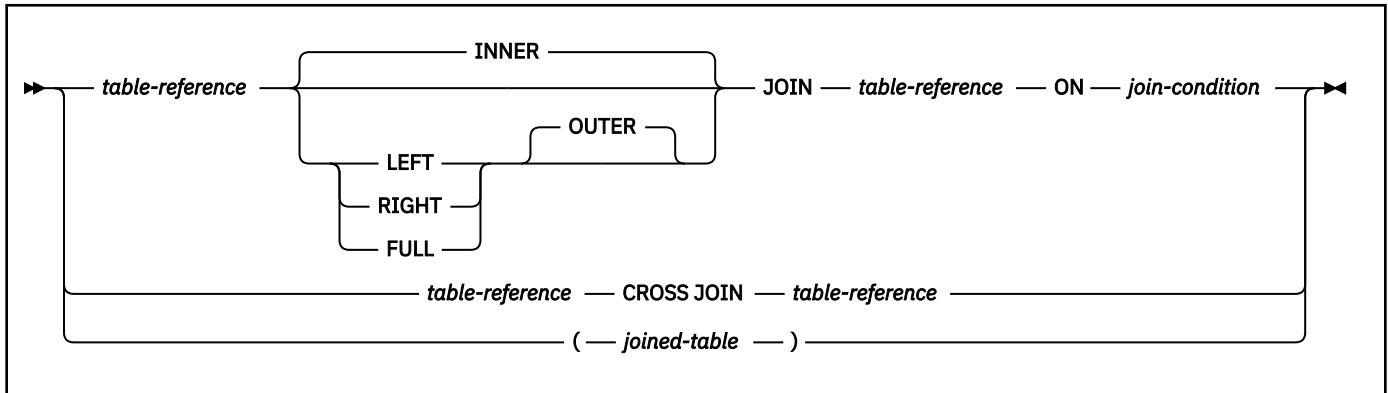

Cross joins represent the cross product of the tables, where each row of the left table is combined with every row of the right table. Inner joins can be thought of as the cross product of the tables, keeping only the rows where the join condition is true. The result table might be missing rows from either or both of the joined tables. Outer joins include the rows produced by the inner join as well as the missing rows, depending on the type of outer join as follows:

Left outer join

Includes rows from the left table that were missing from the inner join.

Right outer join

Includes rows from the right table that were missing from the inner join.

Full outer join

Includes rows from both the left and right tables that were missing from the inner join.

If a join operator is not specified, INNER is the default. The order in which a LEFT OUTER JOIN or RIGHT OUTER JOIN is performed can affect the result.

A *joined-table* can be used in any context in which any form of the SELECT statement is used. Both a view and a cursor is read-only if its SELECT statement includes a *joined-table*.

If LEFT OUTER JOIN, RIGHT OUTER JOIN, or FULL OUTER JOIN is specified:

- A ROW CHANGE TIMESTAMP expression can only be referenced in a subselect of the outer join if the table designator identifies a base table that includes a row change timestamp column.
- The RID built-in function and the ROW CHANGE TOKEN expression must not be specified in the subselect that contains the FROM clause.

Related concepts

[Investigating join operations \(Db2 Performance\)](#)

Related tasks

[Joining data from more than one table \(Db2 Application programming and SQL\)](#)

Related reference

[Examples of subselects](#)

You can use the various clauses of the subselect to construct queries.

join-condition

join-condition specifies the conditions of a join that is used in a query.

join-condition

For INNER, LEFT OUTER, and RIGHT OUTER joins:

→ *search-condition* →

For FULL OUTER joins:

→ *full-join-expression* = *full-join-expression* →
 AND

full-join-expression:

→ *column-name* | *cast-function*¹ →
 COALESCE (*column-name* | *cast-function*¹ , *column-name* | *cast-function*¹) →

Notes:

¹ *cast-function* must only contain a column and the casting data type must be a distinct type or the data type upon which the distinct type was based.

For INNER, LEFT OUTER, and RIGHT OUTER joins, the *join-condition* is a *search-condition* that must conform to these rules:

- With one exception, It cannot contain any subqueries. If the *join-table* that contains the *join-condition* in the associated FROM clause is composed of only INNER joins, the *join-condition* can contain subqueries.
- Any column that is referenced in an expression of the *join-condition* must be a column of one of the operand tables of the associated join operator (in the scope of the same *joined-table* clause).

For a FULL OUTER (or FULL) join, the *join-condition* is a search condition in which the predicates can only be combined with AND. In addition, each predicate must have the form 'expression = expression', where one expression references only columns of one of the operand tables of the associated join operator, and the other expression references only columns of the other operand table. The values of the expressions must be comparable. Implicit cast between numeric and string data types is not supported for FULL OUTER join.

Each *full-join-expression* in a FULL OUTER join must include a column name or a cast function that references a column. The COALESCE function is allowed.

For any type of join, column references in an expression of the *join-condition* are resolved using the rules for resolution of column name qualifiers specified in “[Resolution of column name qualifiers and column names](#)” on page 223 before any rules about which tables the columns must belong to are applied.

Related reference

[Examples of subselects](#)

You can use the various clauses of the subselect to construct queries.

Join operations

A *join-condition* specifies pairings of T1 and T2, where T1 and T2 are the left and right operand tables of its associated JOIN operator. For all possible combinations of rows T1 and T2, a row of T1 is paired with a row of T2 if the *join-condition* is true.

When a row of T1 is joined with a row of T2, a row in the result consists of the values of that row of T1 concatenated with the values of that row of T2. The execution might involve the generation of a null row. The *null row* of a table consists of a null value for each column of the table, regardless of whether the columns allow null values.

The following summarizes the results of the join operations:

- The result of T1 INNER JOIN T2 consists of their paired rows.
- The result of T1 LEFT OUTER JOIN T2 consists of their paired rows and, for each unpaired row of T1, the concatenation of that row with the null row of T2. All columns derived from T2 allow null values.
- The result of T1 RIGHT OUTER JOIN T2 consists of their paired rows and, for each unpaired row of T2, the concatenation of that row with the null row of T1. All columns derived from T1 allow null values.
- The result of T1 FULL OUTER JOIN T2 consists of their paired rows and, for each unpaired row of T1, the concatenation of that row with the null row of T2, and for each unpaired row of T2, the concatenation of that row with the null row in T1. All columns of the result table allow null values.
- The result of T1 CROSS JOIN T2 consists of each row of T1 paired with each row of T2. CROSS JOIN is also known as Cartesian product.

A join operation is part of a FROM clause. For the purpose of predicting which rows will be returned from a SELECT statement containing a join operation, assume that the join operation is performed before the other clauses in the statement.

A cross join can also be specified without the CROSS JOIN syntax, by listing the two tables in the FROM clause separated by commas without using a WHERE clause to supply join criteria.

Related reference

[Examples of subselects](#)

You can use the various clauses of the subselect to construct queries.

where-clause

The WHERE clause specifies a result table that consists of those rows of R for which the search condition is true. R is the result of the FROM clause of the subselect.

where-clause

```
►► WHERE — search-condition ◄◄
```

The search condition must conform to the following rules:

- Each column name must unambiguously identify a column of R or be a correlated reference. A column name is a correlated reference if it identifies a column of a table, view, *common-table-expression*, or *nested-table-expression* that is identified in an outer subselect.
- An aggregate function must not be specified unless the WHERE clause is specified in a subquery of a HAVING clause and the argument of the function is a correlated reference to a group.

Any subquery in the *search-condition* is effectively executed for each row of R and the results are used in the application of the *search-condition* to the given row of R. A subquery is actually executed for each row of R only if it includes a correlated reference. In fact, a subquery with no correlated references is executed just one time, whereas a subquery with a correlated reference might have to be executed one time for each row.

If row access controls are enabled for a table and no other row permission is defined, the row access control search condition is the default row permission, $1 = 0$. If only one row permission is defined, the row access control search condition is the search conditions that are specified by that permission. Otherwise, if multiple row permissions are defined for a table, the row access control search condition is derived by application of the logical OR operator to the search conditions that are specified by each row permission. This row access control search condition, as a whole, is connected by application of the logical AND operator to the search conditions specified by the WHERE clause and has the same precedence level as other search conditions in the WHERE clause. This process is repeated for each *table-reference* in the FROM clause of the subselect for which row access controls are enabled.

The row access control search condition acts as a filter to the *table-reference* to determine the results of the *table-reference* that are accessible to the authorization ID or role of the subselect. Because the order in which operators are evaluated is undefined for operators at the same precedence level, other search conditions in the WHERE clause might be evaluated before the row access control search condition. So, the other search conditions have access to the rows that are restricted by the row permission rules. To ensure that sensitive data is protected, the predicates that reference user-defined functions that are defined with the NOT SECURED option are always evaluated after the row access control search condition.

The column access control does not affect the operation of the WHERE clause.

Related concepts

[Subqueries \(Db2 Application programming and SQL\)](#)

Related tasks

[Writing efficient subqueries \(Db2 Performance\)](#)

Related reference

[Examples of subselects](#)

You can use the various clauses of the subselect to construct queries.

group-by-clause

The GROUP BY clause specifies a result table that consists of a grouping of the rows of intermediate result table that is the result of the previous clause.

group-by-clause

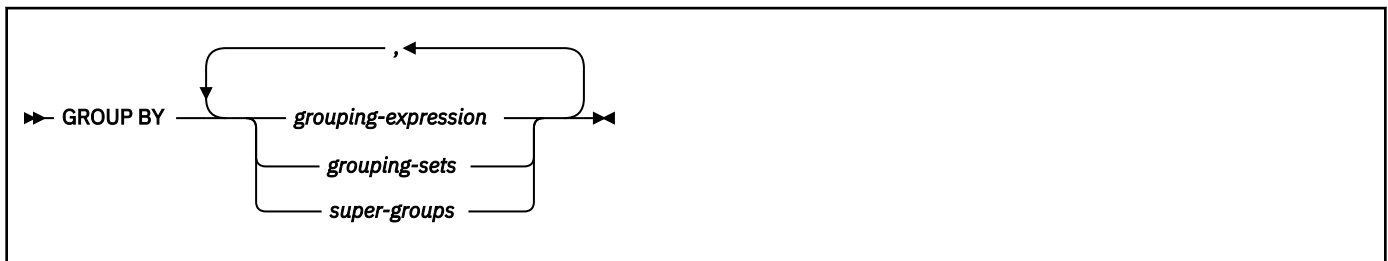

In its simplest form, a GROUP BY clause contains a *grouping-expression*.

grouping-expression

A *grouping-expression* is an expression that defines the grouping of R. The following restrictions apply to *grouping-expression*:

- If *grouping-expression* is a single column, the column name must unambiguously identify a column of R.
- The result of *grouping-expression* cannot be a LOB data type (or a distinct type that is based on a LOB) or an XML data type.
- *grouping-expression* cannot include any of the following items:
 - A correlated column
 - A host variable
 - An aggregate function
 - Any function or expression that is not deterministic or that is defined to have an external action

- A scalar fullselect
- A CASE expression whose *searched-when-clause* contains a quantified predicate, an IN predicate using a fullselect, or an EXISTS predicate

More complex forms of the GROUP BY clause include *grouping-sets* and *super-groups*.

The result of GROUP BY is a set of groups of rows. In each group of more than one row, all values of each *grouping-expression* are equal, and all rows with the same set of values of the *grouping-expression* are in the same group. For grouping, all null values for a *grouping-expression* are considered equal.

If a *grouping-expression* contains DECFLOAT values, the DECFLOAT values with the same value will be in the same group. But the number of digits returned for each group is unpredictable.

Because every row of a group contains the same value of any *grouping-expression*, a *grouping-expression* can be used in a search condition in a HAVING clause or an expression in a SELECT clause, or in a *sort-key-expression* of an ORDER BY clause. In each case, the reference specifies only one value for each group. For example, if *grouping-expression* is col1+col2, col1+col2+3 would be an allowed expression in the select list. Associative rules for expressions do not allow the similar expression of 3+col1+col2, unless parentheses are used to ensure that the corresponding expression is evaluated in the same order. Thus, 3+(col1+col2) would also be allowed in the select list. If the concatenation operator is used, *grouping-expression* must be used exactly as the expression was specified in the select list.

If a *grouping-expression* contains varying-length strings with trailing blanks, the values in the group can differ in the number of trailing blanks and might not all have the same length. In that case, a reference to *grouping-expression* still specifies only one value for each group, but the value for a group is chosen arbitrarily from the available set of values. Thus, the actual length of the result value is unpredictable.

Row access controls do not affect the operation of the GROUP BY clause.

Related links:

- [select-clause](#)
- [“Examples of subselects” on page 1048](#)

grouping-sets

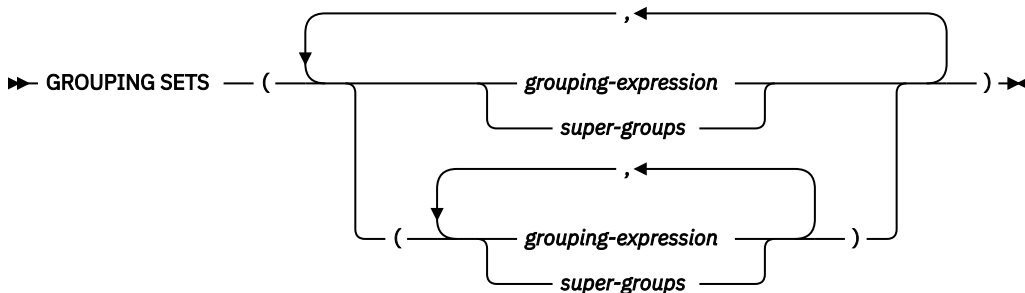

A *grouping-sets* specification can be used to specify multiple grouping clauses in a single statement. This can be thought of as the union of two or more groups of rows into a single result set. It is logically equivalent to the union of multiple subselects with the GROUP BY clause in each subselect corresponding to one grouping set. A grouping set can be a single element or can be a list of elements delimited by parentheses, where an element is either a *grouping-expression* or a *super-group*. The groups can be computed with a single pass over the base table using *grouping-sets*.

Grouping sets are the fundamental building blocks for GROUP BY operations. A simple GROUP BY with a single column can be considered a grouping set with one element. For example, the following clauses are equivalent:

Simple GROUP BY clause	Equivalent GROUPING SETS clause
GROUP BY a	GROUP BY GROUPING SETS((a))

Simple GROUP BY clause	Equivalent GROUPING SETS clause
GROUP BY a, b, c	GROUP BY GROUPING SETS((a, b, c))

Non-aggregation columns from the select list of the subselect that are excluded from a grouping set will return a null for such columns for each row generated for that grouping set. This reflects the fact that aggregation was done without considering the values for those columns.

If GROUPING SETS is specified, a *table-reference* in the associated FROM clause must not contain a column defined with a field procedure.

Related links:

- [“Examples of grouping sets, rollup, and cube queries” on page 1054](#)

super-groups

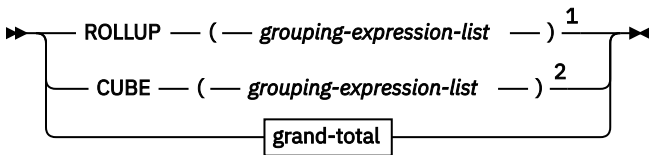

grouping-expression-list

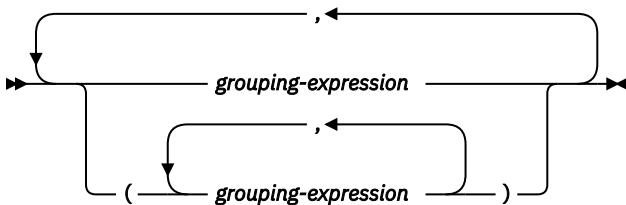

grand-total

➤ (—) ➤

Notes:

- ¹ Alternate specification when used alone in a group-by-clause is: grouping-expression-list WITH ROLLUP.
- ² Alternate specification when used alone in group-by-clause is: grouping-expression-list WITH CUBE.

ROLLUP (grouping-expression-list)

A *ROLLUP grouping* produces a result set that contains *sub-total* rows in addition to the "regular" grouped rows. *Sub-total* rows are "super-aggregate" rows that contain further aggregates whose values are derived by applying the same aggregate functions that were used to obtain the grouped rows. These rows are called sub-total rows, because that is their most common use. However, any aggregate function can be used for the aggregation.

A ROLLUP grouping is a series of *grouping-sets*. The *n* elements of the ROLLUP translate to *n+1* grouping sets.

The general specification of a ROLLUP with *n* elements, as shown in the first column of the following table, is equivalent to the *n+1* grouping sets as shown in the second column of the table:

ROLLUP clause with <i>n</i> elements	Equivalent GROUPING SETS clause
GROUP BY ROLLUP(C ₁ , C ₂ , . . . , C _{<i>n</i>-1} , C _{<i>n</i>})	GROUP BY GROUPING SETS((C ₁ , C ₂ , . . . , C _{<i>n</i>-1} , C _{<i>n</i>}) (C ₁ , C ₂ , . . . , C _{<i>n</i>-1}) ⋮ (C ₁ , C ₂) (C ₁) ()

Note: The order in which the elements of the *grouping-expression-list* are specified is significant for ROLLUP. As the following table shows, the initial element in the *grouping-expression-list* for the ROLLUP is the final element in the GROUPING SET.

ROLLUP clause	Equivalent GROUPING SETS clause
GROUP BY ROLLUP(a, b)	GROUP BY GROUPING SETS((a, b) (a) ())
GROUP BY ROLLUP(b, a)	GROUP BY GROUPING SETS((b, a) (b) ())

The ORDER BY clause is the only way to guarantee the order of the rows in the result set.

Related links:

- [“GROUPING aggregate function” on page 363](#)
- [“order-by-clause” on page 1043](#)
- [“Examples of grouping sets, rollup, and cube queries” on page 1054](#)

CUBE (*grouping-expression-list*)

A *CUBE grouping* produces a result set that contains all the rows of a ROLLUP aggregation and, in addition, contains "cross-tabulation" rows. *Cross-tabulation* rows are additional "super-aggregate" rows that are not part of an aggregation with sub-totals.

Similar to a ROLLUP, a CUBE grouping can also be thought of as a series of *grouping-sets*. In the case of a CUBE, all permutations of the cubed *grouping-expression-list* are computed along with the grand total. Therefore, the *n* elements of a CUBE translate to 2ⁿ *grouping-sets*.

For example, the following clauses are equivalent:

CUBE clause	Equivalent GROUPING SETS clause
GROUP BY CUBE(a, b, c)	GROUP BY GROUPING SETS((a, b, c) (a, b) (a, c) (b, c) (a) (b) (c) ())

Note: The three elements of the CUBE translate into eight grouping sets.

The order specified for the elements does not matter for CUBE. CUBE (DayOfYear, Sales_Person) and CUBE (Sales_Person, DayOfYear) yield the same result sets (the result sets might not be in the same order).

The ORDER BY clause is the only way to guarantee the order of the rows in the result set.

Related links:

- [“GROUPING aggregate function” on page 363](#)
- [“order-by-clause” on page 1043](#)
- [“Examples of grouping sets, rollup, and cube queries” on page 1054](#)

grouping-expression-list

A *grouping-expression-list* is used within a ROLLUP or CUBE clause to define the number of elements in the ROLLUP or CUBE operation. The number of elements is controlled by using parentheses to delimit elements with multiple *grouping-expression* elements.

For example, suppose that a query is to return the total expenses for the ROLLUP of City within Province but not within County. Without a *grouping-expression-list*, the following clause results in unwanted subtotal rows for County:

```
GROUP BY ROLLUP(Province, County, City)
```

Compare the equivalent GROUPING SETS clause:

```
GROUP BY GROUPING SETS((Province, County, City)
                        (Province, County)
                        (Province)
                        ( ) )
```

In the following clause, the composite (County, City) forms one element in the ROLLUP clause and, therefore, a query that uses the following clause will yield the required result:

```
GROUP BY ROLLUP(Province, (County, City))
```

In other words, this is a two-element ROLLUP, which is equivalent to the following GROUPING SETS clause:

```
GROUP BY GROUPING SETS((Province, County, City)
                        (Province)
                        ( ) )
```

Related links:

- [“GROUPING aggregate function” on page 363](#)
- [“order-by-clause” on page 1043](#)
- [“Examples of grouping sets, rollup, and cube queries” on page 1054](#)

grand-total

Both ROLLUP and CUBE return a row which is the overall aggregation (grand total). This can be separately specified with empty parentheses within the GROUPING SETS clause. It can also be specified directly in the GROUP BY clause, although there is no effect on the result of the query.

Related links:

- [“Examples of grouping sets, rollup, and cube queries” on page 1054](#)

Combined groupings

The different types of GROUP BY clause can be combined. When simple *grouping-expression* expressions are combined with other groups, those expressions are prepended to the resulting *grouping sets*. When ROLLUP or CUBE expressions are combined, those expressions form additional grouping set entries on the remaining expression, according to the definition of either a ROLLUP expression or a CUBE expression.

Table 166. Combined grouping-expression and equivalent GROUPING SETS clauses

GROUP BY clause with combined <i>grouping-expression</i>	Equivalent GROUP BY clause with GROUPING SETS clause
GROUP BY a, ROLLUP(b,c)	GROUP BY GROUPING SETS((a,b,c) (a,b) (a))
GROUP BY a, b, ROLLUP(c,d)	GROUP BY GROUPING SETS((a,b,c,d) (a,b,c) (a,b))

Table 166. Combined grouping-expression and equivalent GROUPING SETS clauses (continued)

GROUP BY clause with combined grouping-expression	Equivalent GROUP BY clause with GROUPING SETS clause
GROUP BY ROLLUP(a), ROLLUP(b,c)	GROUP BY GROUPING SETS((a,b,c) (a,b) (a) (b,c) (b) ())
GROUP BY ROLLUP(a), CUBE(b,c)	GROUP BY GROUPING SETS((a,b,c) (a,b) (a,c) (a) (b,c) (b) (c) ())
GROUP BY CUBE(a,b), ROLLUP(c,d)	GROUP BY GROUPING SETS((a,b,c,d) (a,b,c) (a,b) (a,c,d) (a,c) (a) (b,c,d) (b,c) (b) (c,d) (c) ())
GROUP BY a, ROLLUP(a,b)	GROUP BY GROUPING SETS((a,b) (a))

1

Note:

1. Combined grouping sets also eliminate duplicates within each grouping set.

A more complete example of combining grouping sets is to construct a result set that eliminates certain rows that might be returned for a full CUBE aggregation. For example, consider the following GROUP BY clause:

```
GROUP BY Region,
        ROLLUP(Sales_Person, WEEK(Sales_Date)),
        CUBE(YEAR(Sales_Date), MONTH (Sales_Date))
```

The column listed immediately to the right of GROUP BY is grouped, the columns within the parenthesis following ROLLUP are rolled up, and the columns within the parenthesis following CUBE are cubed. Thus, the GROUP BY clause results in a cube of MONTH within YEAR which is then rolled up within WEEK within Sales_Person within the Region aggregation. This GROUP BY does not result in any grand total row or any cross-tabulation rows on Region, Sales_Person or WEEK(Sales_Date), so it produces fewer rows than the following clause:

```
GROUP BY ROLLUP (Region, Sales_Person, WEEK(Sales_Date),
                YEAR(Sales_Date), MONTH(Sales_Date))
```

having-clause

The HAVING clause specifies a result table that consists of those groups of the intermediate result table for which the search-condition is true. The intermediate result table is the result of the previous clause. If this clause is not GROUP BY, the intermediate result table is considered a single group with no grouping columns of the previous clause of the subselect.

having-clause

► HAVING — *search-condition* ◄

Each *column-name* in *search-condition* must be one of the following:

- Unambiguously identify a grouping column of the intermediate result table
- Be specified within an aggregate function²²
- Be a correlated reference. A *column-name* is a correlated reference if it identifies a column of a table, view, *common-table-expression*, or *nested-table-expression* that is identified in an outer subselect

A group of the intermediate result table to which the search condition is applied supplies the argument for each function in the search condition, except for any function whose argument is a correlated reference.

If the search condition contains a subquery, the subquery can be thought of as being executed each time the search condition is applied to a group of the intermediate result table, and the results used in applying the search condition. In actuality, the subquery is executed for each group only if it contains a correlated reference. For an illustration of the difference, see [Example 4](#) and [Example 5](#).

A correlated reference to a group of the intermediate result table must either identify a grouping column or be contained within an aggregate function.

When HAVING is used without GROUP BY, any expression or column name in the select list must appear within an aggregate function.

The RID built-in function and the ROW CHANGE expression cannot be specified in a HAVING clause unless they are within an aggregate function.

Row access controls do not affect the operation of the HAVING clause.

Related concepts

[Subqueries \(Db2 Application programming and SQL\)](#)

Related tasks

[Writing efficient subqueries \(Db2 Performance\)](#)

Related reference

[Examples of subselects](#)

You can use the various clauses of the subselect to construct queries.

order-by-clause

The ORDER BY clause specifies an ordering of the rows of the result table.

order-by-clause

²² See Chapter 4, “Built-in functions,” on page 341 for restrictions that apply to the use of aggregate functions.

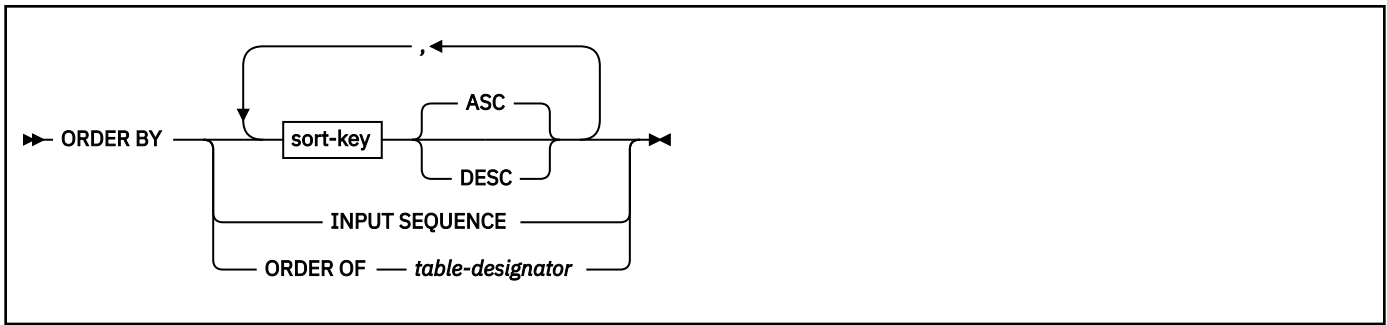

sort-key:



A subselect that contains an ORDER BY clause cannot be specified in the outermost fullselect of a view. If the subselect is not enclosed within parentheses and is not the outermost fullselect, the ORDER BY clause cannot be specified.

An ORDER BY clause that is specified in a subselect only affects the order of the rows that are returned by the query if the subselect is the outermost fullselect, except when a nested subselect includes an ORDER BY clause and the outermost fullselect specifies that the ordering of the rows should be retained (by using the ORDER OF *table-designator* clause).

Multiple ORDER BY clauses can be specified in the same subselect if each clause is separated with parentheses.

INPUT SEQUENCE

Indicates that the result table reflects the input order of the rows specified in the VALUES clause of an INSERT statement. INPUT SEQUENCE ordering can be specified only when an INSERT statement is specified in a *from-clause*.

ORDER OF *table-designator*

Specifies that the same ordering of the rows for the result table that is designated by *table-designator* should be applied to the result table of the subselect (or fullselect) that contains the ORDER OF specification. There must be a table reference in the FROM clause of the subselect (or fullselect) that specifies this clause and matches *table-designator*.

For an ORDER BY clause in an OLAP specification, *table-designator* must not specify a table function, a collection-derived table, a materialized view, a nested table expression that is materialized, an alias, or a synonym.

sort-key

A *column-name*, *integer*, or *sort-key-expression* that specifies the value that is to be used to order the rows of the result of the subselect.

If a single *sort-key* is identified, the rows are ordered by the values of that *sort-key*. If more than one *sort-key* is identified, the rows are ordered by the values of the first *sort-key*, then by the values of the second *sort-key*, and so on. A *sort-key* cannot be a LOB or XML expression.

The result table can be ordered by a named column in the select list by specifying a *sort-key* that is an integer or the column name. The result table can be ordered by an unnamed column in the select list by specifying a *sort-key* that is an integer or, in some cases, by a *sort-key-expression* that matches the expression in the select list.

column-name

An identifier that usually identifies a column of the result table. In this case, *column-name* must be the name of a named column in the select list. If the *fullselect* includes a set operator, the column name cannot be qualified.

If the query is a *subselect*, the *column-name* can also identify a column name of a table, view, or nested table expression identified in the FROM clause, including a column that is defined as implicitly hidden. The subselect must not include any of the following:

- DISTINCT in the select list
- Aggregate functions in the select list
- GROUP BY clause

integer

An unsigned integer that must be greater than 0 and not greater than the number of columns in the result table. The integer *n* identifies the *n*th column of the result table.

sort-key-expression

An expression that is not simply a *column-name* or unsigned integer constant. The query to which ordering is applied must be a *subselect* to use this form of the *sort-key*.

The *sort-key-expression* cannot include an expression that is not deterministic or a function that is defined to have an external action except for the RID built-in function and the ROW CHANGE expression. Any column name in the expression must conform to the rules described [Column names in sort keys](#). If *sort-key-expression* includes an aggregate function, the input arguments to that function must not reference a named column in the select list that is derived from an aggregate function.

If DISTINCT is used in the select list of the *subselect*, *sort-key-expression* must match an expression in the select list of the *subselect*. *Scalar-fullselects* are never matched.

If the *subselect* is grouped, the *sort-key-expression* might or might not be in the select list of the *subselect*. When *sort-key-expression* is not in the select list the following rules apply:

- Each expression in the ORDER BY clause must either:
 - Use one or more grouping expressions
 - Use a column name that either unambiguously identifies a grouping column of R or is specified within a aggregate function.
- Each expression in the ORDER BY clause must not contain a scalar fullselect.

ASC

Uses the values of the *sort-key* in ascending order.

ASC is the default.

DESC

Uses the values of the *sort-key* in descending order.

Ordering is performed in accordance with the comparison rules described in [Chapter 2, “Language elements in SQL,”](#) on page 75, beginning on page “Numeric comparisons” on page 156. The null value is higher than all other values. If your ordering specification does not determine a complete ordering, rows with duplicate values of the last identified *sort-key* have an arbitrary order. If you do not specify ORDER BY, the rows of the result table have an arbitrary order.

Column access controls do not effect the operation of the ORDER BY clause. The order is based on the original column values. However, after column masks are applied, the masked values in the final result table might not reflect the order of the original column values.

Column names in sort keys: A column name in a *sort-key* must conform to the following rules:

- If the column name is qualified, the query must be a *subselect*. The column name must unambiguously identify a column of a table, view, or nested table expression in the FROM clause of the subselect; its value is used to compute the value of the sort specification.

- If the column name is unqualified and the query is a *subselect*:
 - If the column name is identical to the name of more than one column of the result table, the column name must unambiguously identify a column of some table, view, or nested table expression in the FROM clause of the ordering subselect.
 - If the column name is identical to one column of the result table, its value is used to compute the value of the sort specification.
 - If the column name is not identical to a column in the result table, it must unambiguously identify a column of a table, view, or nested table expression in the FROM clause of the subselect. If the column name is identical to one column of a table, view, or nested table expression in the FROM clause of the subselect, its value is used to compute the value of the sort specification.

Related reference

Examples of subselects

You can use the various clauses of the subselect to construct queries.

offset-clause

The *offset-clause* specifies the number of rows of the result table to skip before any rows are retrieved.

offset-clause

► OFFSET — *offset-row-count* — ROW ROWS ►

The *offset-clause* specifies that the number of rows specified by *offset-row-count* should be skipped before rows are retrieved. If *offset-clause* is not specified, the default is equivalent to OFFSET 0 ROWS. If *offset-row-count* specifies more rows than the number of rows in the intermediate result table, the intermediate result table is treated as an empty result table.

offset-row-count

A constant or variable that specifies the number of rows to skip before any rows are retrieved. *offset-row-count* must be a numeric value that is a positive number or zero. If the value is not a BIGINT value, the value is cast to a BIGINT value. *offset-row-count* must not be the null value.

When the *offset-clause* is specified as a prepare attribute, *offset-row-count* must not reference a variable.

A subselect or fullselect that contains an *offset-clause* is only allowed as the outermost fullselect in a prepared SQL statement or a DECLARE CURSOR statement. A subselect or fullselect that contains an *offset-clause* is not allowed in other contexts including the following contexts:

- The definition of a view
- The definition of a materialized query table
- The RETURN statement of an SQL table function
- The definition of a row permission
- The definition of a column mask
- The outermost fullselect for a sensitive dynamic cursor

An *offset-clause* can also be specified in a SELECT INTO statement.

If a subselect, fullselect, or SELECT INTO statement includes an *offset-clause*, the select list of that subselect, fullselect, or SELECT INTO statement must not contain an expression that is not deterministic or that has external action.

If the fullselect contains an SQL data change statement in the FROM clause, all rows of the result table are modified regardless of the number of rows to skip.

The *offset-clause* must not be specified in the outer fullselect for a sensitive dynamic scrollable cursor.

Determining a predictable set of rows to skip requires the specification of an ORDER BY clause with sort keys that uniquely identify the sort order of each row in the intermediate result table. If the intermediate result table includes duplicate sort keys for some rows, the order of these rows is not deterministic. If there is no ORDER BY clause, the intermediate result table is not in a deterministic order. If the order of the intermediate result table is not deterministic, the set of skipped rows is unpredictable.

If both the *offset-clause* and the ORDER BY clause are specified, the ordering is performed on the entire result table prior to skipping the specified number of rows.

Row access controls can indirectly affect the *offset-clause* because row access controls affect the rows that are accessible to the authorization ID or role of the fullselect. Column access controls do not affect the *offset-clause*.

The *offset-clause* can be used to return rows from a point in the result table to the end of the result table. In this case, the *fetch-clause* is not specified.

Notes

Syntax alternatives:

The *fetch-clause* is an alternative for setting the number of rows to skip when specifying the maximum number of rows to retrieve. See [“fetch-clause” on page 1047](#).

Related tasks

[Fetching a limited number of rows \(Db2 Performance\)](#)

Related reference

[Examples of subselects](#)

You can use the various clauses of the subselect to construct queries.

fetch-clause

The *fetch-clause* limits the number of rows that can be fetched.

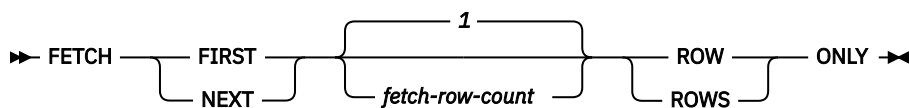

The *fetch-clause* sets a maximum number of rows that can be retrieved. It specifies that an application does not want to retrieve more than *fetch-row-count* rows, regardless of how many rows there might be in the intermediate result table when this clause is not specified. An attempt to fetch beyond *fetch-row-count* rows is handled the same way as normal end of data.

A subselect or fullselect that contains a fetch-clause cannot be specified in the following objects:

- The outermost fullselect of a view
- The definition of a materialized query table

A fetch-clause can also be specified in a SELECT INTO statement.

Determining a predictable set of rows to retrieve requires the specification of an ORDER BY clause with sort keys that would uniquely identify the sort order of each row in the intermediate result table. If the intermediate result table includes duplicate sort keys for some rows, the order of these rows is not deterministic. If there is no ORDER BY clause, the intermediate result table is not in a deterministic order. If the order of the intermediate result table is not deterministic, the set of rows retrieved is unpredictable. If both the fetch-clause and the ORDER BY clause are specified, the fetch-clause is processed on the ordered data.

If the fullselect contains an SQL data change statement in the FROM clause, all the rows are modified regardless of the limit on the number of rows fetched.

fetch-row-count

A constant or variable that specifies the maximum number of rows to retrieve. *fetch-row-count* must be a numeric value that is a positive number or zero. If the value is not BIGINT, the value is cast to a BIGINT value. *fetch-row-count* must not be the null value.

When the fetch-clause is specified as a prepare attribute, *fetch-row-count* must not reference a variable.

Use of the fetch-clause with a constant for *fetch-row-count* that is not greater than the maximum big integer influences query optimization of the subselect or fullselect, based on the fact that, at most, a known number of rows will be retrieved.

Limiting the result table to a specified number of rows can improve performance. In some cases, the database manager will cease processing the query when it has determined the specified number of rows. If the *offset-clause* is also specified with a constant for *offset-row-count*, the database manager will also consider the offset value constant in determining when to cease processing.

Row access controls can indirectly affect the fetch-clause because row access controls affect the rows that are accessible to the authorization ID or role of the subselect or fullselect. Column access controls do no affect the fetch-clause.

Notes:

Syntax alternatives:

- The keywords FIRST and NEXT can be used interchangeably. The result is unchanged; however, using the keyword NEXT is generally more readable when using the *offset-clause*.
- The keywords ROW and ROWS can be used interchangeably. The result is unchanged, however, using ROWS is generally more readable when associated with a number of rows other than 1.
- The following alternatives are supported for compatibility with SQL used by other database products. These alternatives are non-standard and should not be used.

Alternative syntax	Equivalent syntax
LIMIT x	FETCH FIRST x ROWS ONLY
LIMIT x OFFSET y	OFFSET y ROWS FETCH NEXT x ROWS ONLY
LIMIT y, x	OFFSET y ROWS FETCH NEXT x ROWS ONLY

Related concepts

[Fast implicit close \(Db2 Performance\)](#)

Related tasks

[Fetching a limited number of rows \(Db2 Performance\)](#)

Related reference

[Examples of subselects](#)

You can use the various clauses of the subselect to construct queries.

[offset-clause](#)

The *offset-clause* specifies the number of rows of the result table to skip before any rows are retrieved.

Examples of subselects

You can use the various clauses of the subselect to construct queries.

The following example subselects illustrate how to use the various clauses of the subselect to construct queries.

Example 1: Show all rows of the table DSN8C10.EMP.

```
SELECT * FROM DSN8C10.EMP;
```

Example 2: Show the job code, maximum salary, and minimum salary for each group of rows of DSN8C10.EMP with the same job code, but only for groups with more than one row and with a maximum salary greater than 50000.

```
SELECT JOB, MAX(SALARY), MIN(SALARY)
FROM DSN8C10.EMP
GROUP BY JOB
HAVING COUNT(*) > 1 AND MAX(SALARY) > 50000;
```

Example 3: For each employee in department E11, get the following information from the table DSN8C10.EMPPROJACT: employee number, activity number, activity start date, and activity end date. Using the CHAR function, convert the start and end dates to their USA formats. Get the needed department information from the table DSN8C10.EMP.

```
SELECT EMPNO, ACTNO, CHAR(EMSTDATE,USA), CHAR(EMENDATE,USA)
FROM DSN8C10.EMPPROJACT
WHERE EMPNO IN (SELECT EMPNO FROM DSN8C10.EMP
                WHERE WORKDEPT = 'E11');
```

Example 4: Show the department number and maximum departmental salary for all departments whose maximum salary is less than the average salary for all employees. (In this example, the subquery would be executed only one time.)

```
SELECT WORKDEPT, MAX(SALARY)
FROM DSN8C10.EMP
GROUP BY WORKDEPT
HAVING MAX(SALARY) < (SELECT AVG(SALARY)
                      FROM DSN8C10.EMP);
```

Example 5: Show the department number and maximum departmental salary for all departments whose maximum salary is less than the average salary for employees in all other departments. (In contrast to Example 4, the subquery in this statement, containing a correlated reference, would need to be executed for each group.)

```
SELECT WORKDEPT, MAX(SALARY)
FROM DSN8C10.EMP Q
GROUP BY WORKDEPT
HAVING MAX(SALARY) < (SELECT AVG(SALARY)
                      FROM DSN8C10.EMP
                      WHERE NOT WORKDEPT = Q.WORKDEPT);
```

Example 6: For each group of employees hired during the same year, show the year-of-hire and current average salary. (This example demonstrates how to use the AS clause in a FROM clause to name a derived column that you want to refer to in a GROUP BY clause.)

```
SELECT HIREYEAR, AVG(SALARY)
FROM (SELECT YEAR(HIREDATE) AS HIREYEAR, SALARY
      FROM DSN8C10.EMP) AS NEWEMP
GROUP BY HIREYEAR;
```

Example 7: For an example of how to group the results of a query by an expression in the SELECT clause without having to retype the expression, see [Example 4](#) for CASE expressions.

Example 8: Get the employee number and employee name for all the employees in DSN8C10.EMP. Order the results by the date of hire.

```
SELECT EMPNO, FIRSTNAME, LASTNAME
FROM DSN8C10.EMP
ORDER BY HIREDATE;
```

Example 9: Select all the rows from tables T1 and T2 and order the rows such that the rows from table T1 are first and are ordered by column C1, followed by the rows from T2, which are ordered by column C2. The rows of T1 are retrieved by one subselect which is connected to the results of another subselect that retrieves the rows from T2. Each subselect specifies the ordering for the rows from the referenced table. Note that both subselects need to be enclosed in parenthesis because each subselect is not the

outermost fullselect. Because each of the two ORDER BY clauses appears in a parenthesized subselect, neither ORDER BY clause provides an ordering for the outermost result table.

```
(SELECT * FROM T1 ORDER BY C1)
UNION
(SELECT * FROM T2 ORDER BY C2);
```

Example 10: Specify the ORDER BY clause to order the results of a union using the second column of the result table if the union. In this example, the second ORDER BY clause applies to the results of the outermost fullselect (the result of the union) rather than to the second subselect. If the intent is to apply the second ORDER BY clause to the second subselect, the second subselect should be enclosed within parentheses as shown in Example 9.

```
(SELECT * FROM T1 ORDER BY C1)
UNION
SELECT * FROM T2 ORDER BY C2
```

Example 11: Retrieve all rows of table T1 with no specific ordering) and connect the result table to the rows of table T2, which have been ordered by the first column of table T2. The ORDER BY ORDER OF clause in the fullselect specifies that the order of the rows in the result table of the union is to be inherited by the final result.

```
SELECT *
FROM (SELECT * FROM T1
      UNION ALL
      (SELECT * FROM T2 ORDER BY 1)
     ) AS UTABLE
ORDER BY ORDER OF UTABLE;
```

Example 12: The following example uses a query to join data from a table to the result table of a nested table expression. The query uses the ORDER BY ORDER OF clause to order the rows of the result table using the order of the rows of the nested table expression.

```
SELECT T1.C1, T1.C2, TEMP.Cy, TEMP.Cx
FROM T1,
     (SELECT T2.C1, T2.C2 FROM T2 ORDER BY 2) AS TEMP(Cx, Cy)
WHERE Cy = T1.C1
ORDER BY ORDER OF TEMP;
```

Example 13: Using the EMP_ACT table, find the project numbers that have an employee whose salary is in the top three salaries for all employees.

```
SELECT EMP_ACT.EMPNO, PROJNO
FROM EMP_ACT
WHERE EMP_ACT.EMPNO IN
     (SELECT EMPLOYEE.EMPNO
      FROM EMPLOYEE
      ORDER BY SALARY DESC
      FETCH FIRST 3 ROWS ONLY);
```

Example 14: Assume that an external function named ADDYEARS exists. For a given date, the function adds a given number of years and returns a new date. (The data types of the two input parameters to the function are DATE and INTEGER.) Get the employee number and employee name for all employees who have been hired within the last 5 years.

```
SELECT EMPNO, FIRSTNAME, LASTNAME
FROM DSN8C10.EMP
WHERE ADDYEARS(HIREDATE, 5) > CURRENT DATE;
```

To distinguish the different types of joins, to show nested table expressions, and to demonstrate how to combine join columns, the remaining examples use these two tables:

The PARTS table			The PRODUCTS table		
PART	PROD#	SUPPLIER	PROD#	PRODUCT	PRICE
=====	=====	=====	=====	=====	=====
WIRE	10	ACWF	505	SCREWDRIIVER	3.70
OIL	160	WESTERN_CHEM	30	RELAY	7.55
MAGNETS	10	BATEMAN	205	SAW	18.90

PLASTIC	30	PLASTIK_CORP	10	GENERATOR	45.75
BLADES	205	ACE_STEEL			

Example 15: Join the tables on the PROD# column to get a table of parts with their suppliers and the products that use the parts:

```
SELECT PART, SUPPLIER, PARTS.PROD#, PRODUCT
FROM PARTS, PRODUCTS
WHERE PARTS.PROD# = PRODUCTS.PROD#;
```

or

```
SELECT PART, SUPPLIER, PARTS.PROD#, PRODUCT
FROM PARTS INNER JOIN PRODUCTS
ON PARTS.PROD# = PRODUCTS.PROD#;
```

Either one of these two statements give this result:

PART	SUPPLIER	PROD#	PRODUCT
=====	=====	=====	=====
WIRE	ACWF	10	GENERATOR
MAGNETS	BATEMAN	10	GENERATOR
PLASTIC	PLASTIK_CORP	30	RELAY
BLADES	ACE_STEEL	205	SAW

Notice two things about the example:

- There is a part in the parts table (OIL) whose product (#160) is not listed in the products table. There is a product (SCREWDRIVER, #505) that has no parts listed in the parts table. Neither OIL nor SCREWDRIVER appears in the result of the join.

An *outer join*, however, includes rows where the values in the joined columns do not match.

- There is explicit syntax to express that this familiar join is not an outer join but an inner join. You can use INNER JOIN in the FROM clause instead of the comma. Use ON when you explicitly join tables in the FROM clause.

You can specify more complicated join conditions to obtain different sets of results. For example, eliminate the suppliers that begin with the letter A from the table of parts, suppliers, product numbers and products:

```
SELECT PART, SUPPLIER, PARTS.PROD#, PRODUCT
FROM PARTS INNER JOIN PRODUCTS
ON PARTS.PROD# = PRODUCTS.PROD#
AND SUPPLIER NOT LIKE 'A%';
```

The result of the query is all rows that do not have a supplier that begins with A:

PART	SUPPLIER	PROD#	PRODUCT
=====	=====	=====	=====
MAGNETS	BATEMAN	10	GENERATOR
PLASTIC	PLASTIK_CORP	30	RELAY

Example 16: Join the tables on the PROD# column to get a table of all parts and products, showing the supplier information, if any.

```
SELECT PART, SUPPLIER, PARTS.PROD#, PRODUCT
FROM PARTS FULL OUTER JOIN PRODUCTS
ON PARTS.PROD# = PRODUCTS.PROD#;
```

The result is:

PART	SUPPLIER	PROD#	PRODUCT
=====	=====	=====	=====
WIRE	ACWF	10	GENERATOR
MAGNETS	BATEMAN	10	GENERATOR
PLASTIC	PLASTIK_CORP	30	RELAY
BLADES	ACE_STEEL	205	SAW
OIL	WESTERN_CHEM	160	(null)
(null)	(null)	(null)	SCREWDRIVER

The clause FULL OUTER JOIN includes unmatched rows from both tables. Missing values in a row of the result table are filled with nulls.

Example 17: Join the tables on the PROD# column to get a table of all parts, showing what products, if any, the parts are used in:

```
SELECT PART, SUPPLIER, PARTS.PROD#, PRODUCT
FROM PARTS LEFT OUTER JOIN PRODUCTS
ON PARTS.PROD# = PRODUCTS.PROD#;
```

The result is:

PART	SUPPLIER	PROD#	PRODUCT
WIRE	ACWF	10	GENERATOR
MAGNETS	BATEMAN	10	GENERATOR
PLASTIC	PLASTIK_CORP	30	RELAY
BLADES	ACE_STEEL	205	SAW
OIL	WESTERN_CHEM	160	(null)

The clause LEFT OUTER JOIN includes rows from the table identified before it where the values in the joined columns are not matched by values in the joined columns of the table identified after it.

Example 18: Join the tables on the PROD# column to get a table of all products, showing the parts used in that product, if any, and the supplier.

```
SELECT PART, SUPPLIER, PRODUCTS.PROD#, PRODUCT
FROM PARTS RIGHT OUTER JOIN PRODUCTS
ON PARTS.PROD# = PRODUCTS.PROD#;
```

The result is:

PART	SUPPLIER	PROD#	PRODUCT
WIRE	ACWF	10	GENERATOR
MAGNETS	BATEMAN	10	GENERATOR
PLASTIC	PLASTIK_CORP	30	RELAY
BLADES	ACE_STEEL	205	SAW
(null)	(null)	505	SCREWDRIVER

The clause RIGHT OUTER JOIN includes rows from the table identified after it where the values in the joined columns are not matched by values in the joined columns of the table identified before it.

Example 19: The result of Example 16 (a full outer join) shows the product number for SCREWDRIVER as null, even though the PRODUCTS table contains a product number for it. This is because PRODUCTS.PROD# was not listed in the SELECT list of the query. Revise the query using COALESCE so that all part numbers from both tables are shown.

```
SELECT PART, SUPPLIER,
COALESCE(PARTS.PROD#, PRODUCTS.PROD#) AS PRODNUM, PRODUCT
FROM PARTS FULL OUTER JOIN PRODUCTS
ON PARTS.PROD# = PRODUCTS.PROD#;
```

In the result, notice that the AS clause (AS PRODNUM), provides a name for the result of the COALESCE function:

PART	SUPPLIER	PRODNUM	PRODUCT
WIRE	ACWF	10	GENERATOR
MAGNETS	BATEMAN	10	GENERATOR
PLASTIC	PLASTIK_CORP	30	RELAY
BLADES	ACE_STEEL	205	SAW
OIL	WESTERN_CHEM	160	(null)
(null)	(null)	505	SCREWDRIVER

Example 20: For all parts that are used in product numbers less than 200, show the part, the part supplier, the product number, and the product name. Use a nested table expression.

```
SELECT PART, SUPPLIER, PRODNUM, PRODUCT
FROM (SELECT PART, PROD# AS PRODNUM, SUPPLIER
```



```

FROM PARTS
  WHERE PROD# < 200) AS PARTX
LEFT OUTER JOIN PRODUCTS
  ON PRODNUM = PROD#;

```

The result is:

PART	SUPPLIER	PRODNUM	PRODUCT
WIRE	ACWF	10	GENERATOR
MAGNETS	BATEMAN	10	GENERATOR
PLASTIC	PLASTIK_CORP	30	RELAY
OIL	WESTERN_CHEM	160	(null)

Example 21: Examples of statements with DISTINCT specified more than once in a subselect:

```

SELECT DISTINCT COUNT(DISTINCT A1), COUNT(A2)
FROM T1;

```

```

SELECT COUNT(DISTINCT A)
FROM T1
WHERE A3 > 0
HAVING AVG(DISTINCT A4) >1;

```

Example 22: Examples of cross join to combine information for all customers with all states.

Use a cross join to combine information for all customers with all of the states. The cross join combines all rows in both tables and creates a Cartesian product. Assume that the following tables exist:

Customer:

ACOL1	ACOL2
A1	AA1
A2	AA2
A3	AA3

States:

BCOL1	BCOL2
B1	BB1
B2	BB2

The following two select statements produce identical results:

```

SELECT * FROM customer CROSS JOIN states

```

```

SELECT * FROM A, B

```

The result table for either of these select statements looks like the following:

ACOL1	ACOL2	BCOL1	BCOL2
A1	AA1	B1	BB1
A1	AA1	B2	BB2
A2	AA2	B1	BB1
A2	AA2	B2	BB2
A3	AA3	B1	BB1
A3	AA3	B2	BB2

Example 22: Example of using a typed-correlation-clause when referencing a generic table function.

In the following select statement, 'tf6' is a generic table function defined using the CREATE FUNCTION (external table) statement. The *typed-correlation-clause* is used to define the column names and data types of the result table.

```
SELECT c1, c2
FROM T1(tf6('abcd'))
AS z (c1 int, c2 varchar(100));
```

Examples of grouping sets, rollup, and cube queries

You can use GROUPING SETS, ROLLUP, and CUBE clauses of the GROUP BY clause in subselect queries.

The following examples illustrate the use of GROUPING SETS, ROLLUP, and CUBE clauses of the GROUP BY clause in subselect queries. The queries in Examples 1–4 use a subset of the rows in the SALES tables based on the predicate 'WEEK(SALES_DATE) = 13'. The other examples do not specify this predicate.

```
SELECT WEEK(SALES_DATE) AS WEEK,
       DAYOFWEEK(SALES_DATE) AS DAY_WEEK,
       SALES_PERSON, SALES AS UNITS_SOLD
FROM SALES
WHERE WEEK(SALES_DATE) = 13;
```

The previous query returns results similar to the following:

WEEK	DAY_WEEK	SALES_PERSON	UNITS_SOLD
13	6	LUCCHESSI	3
13	6	LUCCHESSI	1
13	6	LEE	2
13	6	LEE	2
13	6	LEE	3
13	6	LEE	5
13	6	GOUNOT	3
13	6	GOUNOT	1
13	6	GOUNOT	7
13	7	LUCCHESSI	1
13	7	LUCCHESSI	2
13	7	LUCCHESSI	1
13	7	LEE	7
13	7	LEE	3
13	7	LEE	7
13	7	LEE	4
13	7	GOUNOT	2
13	7	GOUNOT	18
13	7	GOUNOT	1

Example 1:

A query with a basic GROUP BY clause over 3 columns:

```
SELECT WEEK(SALES_DATE) AS WEEK,
       DAYOFWEEK(SALES_DATE) AS DAY_WEEK,
       SALES_PERSON, SUM(SALES) AS UNITS_SOLD
FROM SALES
WHERE WEEK(SALES_DATE) = 13
GROUP BY WEEK(SALES_DATE), DAYOFWEEK(SALES_DATE), SALES_PERSON
ORDER BY WEEK, DAY_WEEK, SALES_PERSON;
```

The previous query returns results similar to the following:

WEEK	DAY_WEEK	SALES_PERSON	UNITS_SOLD
13	6	GOUNOT	11
13	6	LEE	12
13	6	LUCCHESSI	4
13	7	GOUNOT	21
13	7	LEE	21
13	7	LUCCHESSI	4

Example 2:

The following query produces the result based on two different grouping sets of rows from the SALES table.

```
SELECT WEEK(SALES_DATE) AS WEEK,
       DAYOFWEEK(SALES_DATE) AS DAY_WEEK,
       SALES_PERSON, SUM(SALES) AS UNITS_SOLD
FROM SALES
WHERE WEEK(SALES_DATE) = 13
GROUP BY GROUPING SETS ((WEEK(SALES_DATE), SALES_PERSON),
                        (DAYOFWEEK(SALES_DATE), SALES_PERSON))
ORDER BY WEEK, DAY_WEEK, SALES_PERSON;
```

The previous query returns results similar to the following:

WEEK	DAY_WEEK	SALES_PERSON	UNITS_SOLD
13	-	GOUNOT	32
13	-	LEE	33
13	-	LUCCHESSEI	8
-	6	GOUNOT	11
-	6	LEE	12
-	6	LUCCHESSEI	4
-	7	GOUNOT	21
-	7	LEE	21
-	7	LUCCHESSEI	4

The rows with WEEK 13 are from the first grouping set while the other rows are from the second grouping set.

Example 3:

If you use the three distinct columns involved in the grouping sets in Example 2 in a ROLLUP clause, you can see grouping sets for (WEEK, DAY_WEEK, SALES_PERSON), (WEEK, DAY_WEEK), (WEEK), and *grand-total*.

```
SELECT WEEK(SALES_DATE) AS WEEK,
       DAYOFWEEK(SALES_DATE) AS DAY_WEEK,
       SALES_PERSON, SUM(SALES) AS UNITS_SOLD
FROM SALES
WHERE WEEK(SALES_DATE) = 13
GROUP BY ROLLUP (WEEK(SALES_DATE), DAYOFWEEK(SALES_DATE), SALES_PERSON)
ORDER BY WEEK, DAY_WEEK, SALES_PERSON;
```

The previous query returns results similar to the following:

WEEK	DAY_WEEK	SALES_PERSON	UNITS_SOLD
13	6	GOUNOT	11
13	6	LEE	12
13	6	LUCCHESSEI	4
13	6	-	27
13	7	GOUNOT	21
13	7	LEE	21
13	7	LUCCHESSEI	4
13	7	-	46
13	-	-	73
-	-	-	73

Example 4:

The same query as Example 3, using CUBE instead of ROLLUP results in additional grouping sets for (WEEK, SALES_PERSON), (DAY_WEEK, SALES_PERSON), (DAY_WEEK), and (SALES_PERSON) in the result.

```
SELECT WEEK(SALES_DATE) AS WEEK,
       DAYOFWEEK(SALES_DATE) AS DAY_WEEK,
       SALES_PERSON, SUM(SALES) AS UNITS_SOLD
FROM SALES
WHERE WEEK(SALES_DATE) = 13
GROUP BY CUBE (WEEK(SALES_DATE), DAYOFWEEK(SALES_DATE), SALES_PERSON)
ORDER BY WEEK, DAY_WEEK, SALES_PERSON;
```

The previous query returns results similar to the following:

WEEK	DAY_WEEK	SALES_PERSON	UNITS_SOLD
13	6	GOUNOT	11
13	6	LEE	12
13	6	LUCCHESSI	4
13	6	-	27
13	7	GOUNOT	21
13	7	LEE	21
13	7	LUCCHESSI	4
13	7	-	46
13	-	GOUNOT	32
13	-	LEE	33
13	-	LUCCHESSI	8
13	-	-	73
-	6	GOUNOT	11
-	6	LEE	12
-	6	LUCCHESSI	4
-	6	-	27
-	7	GOUNOT	21
-	7	LEE	21
-	7	LUCCHESSI	4
-	7	-	46
-	-	GOUNOT	32
-	-	LEE	33
-	-	LUCCHESSI	8
-	-	-	73

Example 5:

The following query returns a result set that includes a *grand-total* of the selected rows from the SALES table together with a group of rows aggregated by SALES_PERSON and MONTH.

```
SELECT SALES_PERSON,
       MONTH(SALES_DATE) AS MONTH,
       SUM(SALES) AS UNITS_SOLD
FROM SALES
GROUP BY GROUPING SETS ((SALES_PERSON, MONTH(SALES_DATE)),
                        ())
ORDER BY SALES_PERSON, MONTH;
```

The previous query returns results similar to the following:

SALES_PERSON	MONTH	UNITS_SOLD
GOUNOT	3	35
GOUNOT	4	14
GOUNOT	12	1
LEE	3	60
LEE	4	25
LEE	12	6
LUCCHESSI	3	9
LUCCHESSI	4	4
LUCCHESSI	12	1
-	-	155

Example 6:

This example shows two simple ROLLUP queries followed by a query which treats the two ROLLUP clauses as grouping sets in a single result set and specifies row ordering for each column involved in the grouping sets.

Example 6-1:

```
SELECT WEEK(SALES_DATE) AS WEEK,
       DAYOFWEEK(SALES_DATE) AS DAY_WEEK,
       SUM(SALES) AS UNITS_SOLD
FROM SALES
GROUP BY ROLLUP (WEEK(SALES_DATE), DAYOFWEEK(SALES_DATE))
ORDER BY WEEK, DAY_WEEK;
```

The previous query returns results similar to the following:

WEEK	DAY_WEEK	UNITS_SOLD
13	6	27
13	7	46
13	-	73
14	1	31
14	2	43
14	-	74
53	1	8
53	-	8
-	-	155

Example 6-2:

```
SELECT MONTH(SALES_DATE) AS MONTH,
       REGION,
       SUM(SALES) AS UNITS_SOLD
FROM SALES
GROUP BY ROLLUP (MONTH(SALES_DATE), REGION)
ORDER BY MONTH, REGION;
```

The previous query returns results similar to the following:

MONTH	REGION	UNITS_SOLD
3	Manitoba	22
3	Ontario-North	8
3	Ontario-South	34
3	Quebec	40
3	-	104
4	Manitoba	17
4	Ontario-North	1
4	Ontario-South	14
4	Quebec	11
4	-	43
12	Manitoba	2
12	Ontario-South	4
12	Quebec	2
12	-	8
-	-	155

Example 6-3:

```
SELECT WEEK(SALES_DATE) AS WEEK,
       DAYOFWEEK(SALES_DATE) AS DAY_WEEK,
       MONTH(SALES_DATE) AS MONTH,
       REGION,
       SUM(SALES) AS UNITS_SOLD
FROM SALES
GROUP BY GROUPING SETS (ROLLUP(WEEK(SALES_DATE),
                                DAYOFWEEK(SALES_DATE)),
                        ROLLUP(MONTH(SALES_DATE), REGION))
ORDER BY WEEK, DAY_WEEK, MONTH, REGION;
```

The previous query returns results similar to the following:

WEEK	DAY_WEEK	MONTH	REGION	UNITS_SOLD
13	6	-	-	27
13	7	-	-	46
13	-	-	-	73
14	1	-	-	31
14	2	-	-	43
14	-	-	-	74
53	1	-	-	8
53	-	-	-	8
-	-	3	Manitoba	22
-	-	3	Ontario-North	8
-	-	3	Ontario-South	34
-	-	3	Quebec	40
-	-	3	-	104
-	-	4	Manitoba	17
-	-	4	Ontario-North	1
-	-	4	Ontario-South	14

-	-	4	Quebec	11
-	-	4	-	43
-	-	12	Manitoba	2
-	-	12	Ontario-South	4
-	-	12	Quebec	2
-	-	12	-	8
-	-	-	-	155
-	-	-	-	155

Using the two ROLLUP clauses as grouping sets causes the result to include duplicate rows. There are even two grand total rows.

Observe how the use of ORDER BY has affected the results:

- In the first grouped set, week 53 has been repositioned to the end.
- In the second grouped set, month 12 has now been positioned to the end and the regions now display in alphabetic order.
- Null values are sorted high.

Example 7:

In queries that perform multiple ROLLUP operations in a single pass (such as Example 6-3) you might need to indicate which grouping set produced each row. The following steps demonstrate how to provide a column (called GROUP) which indicates the origin of each row in the result set. *Origin* means which of the two grouping sets produced the row in the result set.

Step 1:

Introduce a way of generating new data values, using a query which selects from the SYSDUMMY1 table. The following query shows how a table (named "X") can be derived with two columns, "R1" and "R2", and one row of data.

```
SELECT R1,R2
FROM (SELECT 'GROUP 1' as R1, 'GROUP 2' as R2
FROM SYSIBM.SYSDUMMY1) AS X(R1,R2);
```

The results are similar to the following:

```
R1      R2
-----
GROUP 1 GROUP 2
```

Step 2:

Form the cross product of the table "X" with the SALES table. The following query adds columns "R1" and "R2" to every row.

```
SELECT R1, R2, WEEK(SALES_DATE) AS WEEK,
DAYOFWEEK(SALES_DATE) AS DAY_WEEK,
MONTH(SALES_DATE) AS MONTH,
REGION,
SALES AS UNITS_SOLD
FROM SALES, (SELECT 'GROUP 1' as R1, 'GROUP 2' as R2
FROM SYSIBM.SYSDUMMY1) AS X(R1,R2);
```

Step 3:

Now the "R1" and "R2" columns can be combined with the grouping sets to include "R1" and "R2" in the rollup analysis.

```
SELECT R1, R2,
WEEK(SALES_DATE) AS WEEK,
DAYOFWEEK(SALES_DATE) AS DAY_WEEK,
MONTH(SALES_DATE) AS MONTH,
REGION, SUM(SALES) AS UNITS_SOLD
FROM SALES, (SELECT 'GROUP 1' as R1, 'GROUP 2' as R2
FROM SYSIBM.SYSDUMMY1) AS X(R1,R2)
GROUP BY GROUPING SETS ((R1, ROLLUP(WEEK(SALES_DATE),
DAYOFWEEK(SALES_DATE))),
(R2, ROLLUP(MONTH(SALES_DATE), REGION)))
ORDER BY WEEK, DAY_WEEK, MONTH, REGION
```

The previous query returns results similar to the following:

R1	R2	WEEK	DAY_WEEK	MONTH	REGION	UNITS_SOLD
GROUP 1	-	13	6	-	-	27
GROUP 1	-	13	7	-	-	46
GROUP 1	-	13	-	-	-	73
GROUP 1	-	14	1	-	-	31
GROUP 1	-	14	2	-	-	43
GROUP 1	-	14	-	-	-	74
GROUP 1	-	53	1	-	-	8
GROUP 1	-	53	-	-	-	8
-	GROUP 2	-	-	-	3 Manitoba	22
-	GROUP 2	-	-	-	3 Ontario-North	8
-	GROUP 2	-	-	-	3 Ontario-South	34
-	GROUP 2	-	-	-	3 Quebec	40
-	GROUP 2	-	-	-	3 -	104
-	GROUP 2	-	-	-	4 Manitoba	17
-	GROUP 2	-	-	-	4 Ontario-North	1
-	GROUP 2	-	-	-	4 Ontario-South	14
-	GROUP 2	-	-	-	4 Quebec	11
-	GROUP 2	-	-	-	4 -	43
-	GROUP 2	-	-	-	12 Manitoba	2
-	GROUP 2	-	-	-	12 Ontario-South	4
-	GROUP 2	-	-	-	12 Quebec	2
-	GROUP 2	-	-	-	12 -	8
-	GROUP 2	-	-	-	-	155
GROUP 1	-	-	-	-	-	155

Step 4:

Because "R1" and "R2" are used in different grouping sets, whenever "R1" is non-null in the result, "R2" is null and whenever "R2" is non-null in the result, "R1" is null. You can consolidate these columns into a single column ("GROUP") using the COALESCE function. You can also use the "GROUP" column in the ORDER BY clause to keep the results of the two grouping sets together.

```

SELECT COALESCE(R1,R2) AS GROUP,
       WEEK(SALES_DATE) AS WEEK,
       DAYOFWEEK(SALES_DATE) AS DAY_WEEK,
       MONTH(SALES_DATE) AS MONTH,
       REGION, SUM(SALES) AS UNITS_SOLD
FROM SALES, (SELECT 'GROUP 1' as R1, 'GROUP 2' as R2
             FROM SYSIBM.SYSDUMMY1) AS X(R1,R2)
GROUP BY GROUPING SETS ((R1, ROLLUP(WEEK(SALES_DATE),
                                     DAYOFWEEK(SALES_DATE))),
                        (R2, ROLLUP(MONTH(SALES_DATE),
                                     REGION)))
ORDER BY GROUP, WEEK, DAY_WEEK, MONTH, REGION;

```

The previous query returns results similar to the following:

GROUP	WEEK	DAY_WEEK	MONTH	REGION	UNITS_SOLD
GROUP 1	13	6	-	-	27
GROUP 1	13	7	-	-	46
GROUP 1	13	-	-	-	73
GROUP 1	14	1	-	-	31
GROUP 1	14	2	-	-	43
GROUP 1	14	-	-	-	74
GROUP 1	53	1	-	-	8
GROUP 1	53	-	-	-	8
GROUP 1	-	-	-	-	155
GROUP 2	-	-	-	3 Manitoba	22
GROUP 2	-	-	-	3 Ontario-North	8
GROUP 2	-	-	-	3 Ontario-South	34
GROUP 2	-	-	-	3 Quebec	40
GROUP 2	-	-	-	3 -	104
GROUP 2	-	-	-	4 Manitoba	17
GROUP 2	-	-	-	4 Ontario-North	1
GROUP 2	-	-	-	4 Ontario-South	14
GROUP 2	-	-	-	4 Quebec	11
GROUP 2	-	-	-	4 -	43
GROUP 2	-	-	-	12 Manitoba	2
GROUP 2	-	-	-	12 Ontario-South	4
GROUP 2	-	-	-	12 Quebec	2

GROUP 2	-	-	12	-	8
GROUP 2	-	-	-	-	155

Example 8:

The following example illustrates the use of various aggregate functions when using a CUBE clause. The example also makes use of cast functions and rounding to produce a decimal result with reasonable precision and scale.

```
SELECT MONTH(SALES_DATE) AS MONTH,
       REGION,
       SUM(SALES) AS UNITS_SOLD,
       MAX(SALES) AS BEST_SALE,
       CAST(ROUND(AVG(DECIMAL(SALES)),2) AS DECIMAL(5,2))
       AS AVG_UNITS_SOLD
FROM SALES
GROUP BY CUBE(MONTH(SALES_DATE), REGION)
ORDER BY MONTH, REGION;
```

The previous query returns results similar to the following:

MONTH	REGION	UNITS_SOLD	BEST_SALE	AVG_UNITS_SOLD
3	Manitoba	22	7	3.14
3	Ontario-North	8	3	2.67
3	Ontario-South	34	14	4.25
3	Quebec	40	18	5.00
3	-	104	18	4.00
4	Manitoba	17	9	5.67
4	Ontario-North	1	1	1.00
4	Ontario-South	14	8	4.67
4	Quebec	11	8	5.50
4	-	43	9	4.78
12	Manitoba	2	2	2.00
12	Ontario-South	4	3	2.00
12	Quebec	2	1	1.00
12	-	8	3	1.60
-	Manitoba	41	9	3.73
-	Ontario-North	9	3	2.25
-	Ontario-South	52	14	4.00
-	Quebec	53	18	4.42
-	-	155	18	3.87

Related reference

[group-by-clause](#)

The GROUP BY clause specifies a result table that consists of a grouping of the rows of intermediate result table that is the result of the previous clause.

fullselect

The fullselect is a component of the *select-statement*, ALTER TABLE statement for the definition of a materialized query table, CREATE TABLE statement, CREATE VIEW statement, DECLARE GLOBAL TEMPORARY TABLE statement, INSERT statement, UPDATE statement, and MERGE statement.

Authorization for fullselect

See [“Authorization for queries” on page 1007](#).

Syntax for *fullselect*

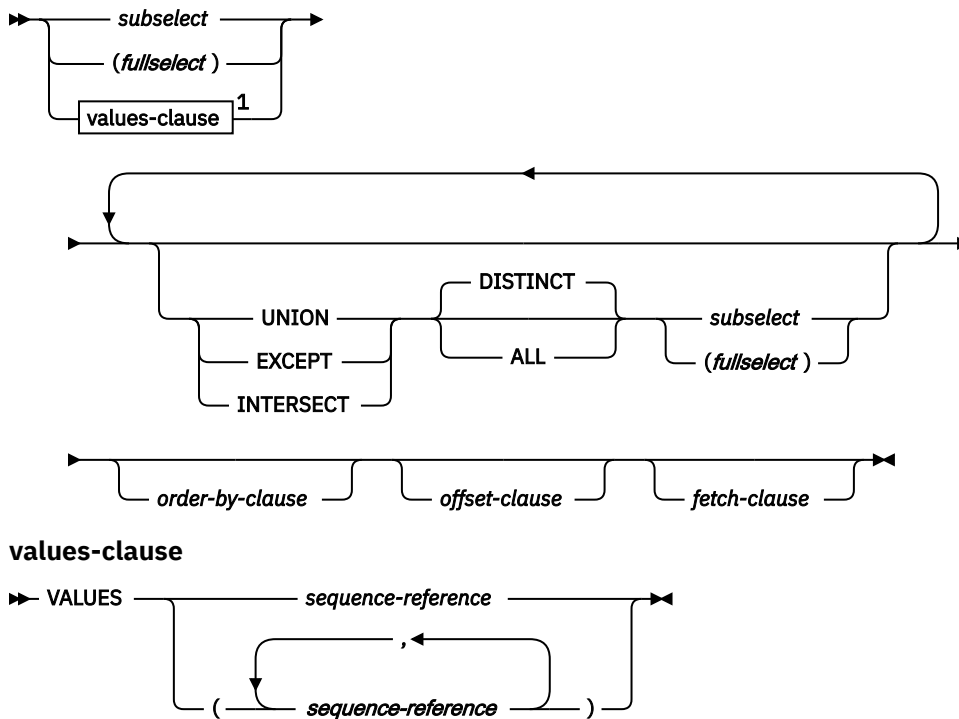

Notes:

¹ If *values-clause* is specified, **UNION**, **EXCEPT**, **INTERSECT**, *order-by-clause*, or *fetch-clause* must not also be specified. If *fullselect* contains a *values-clause*, the *fullselect* must only be specified in a *select-statement* that is referenced by *statement-name* in a **PREPARE** statement.

Description

A *fullselect* that is enclosed in parentheses is called a *subquery*. For example, a subquery can be used in a search condition.

A *scalar-fullselect* is a *fullselect*, enclosed in parentheses, that returns a single result row and a single result column. If the result of the *fullselect* is no rows, then the null value is returned. An error is returned if there is more than one row in the result. For example, a *scalar-fullselect* can be used in the assignment clause of the **DELETE**, **UPDATE** and **MERGE** statements.

A *row-fullselect* is a *fullselect* that returns a single row. An error is returned if there is more than one row in the result. For example, a *row-fullselect* can be used in the assignment clause of the **DELETE** and **UPDATE** statements.

UNION, **EXCEPT**, or **INTERSECT**

The set operators, **UNION**, **EXCEPT**, and **INTERSECT**, correspond to the relational operators union, difference, and intersection. A *fullselect* specifies a result table. If a set operator is not used, the result of the *fullselect* is the result of the specified *subselect*. Otherwise, the result table is derived by combining the two other result tables (R1 and R2) subject to the specified set operator.

UNION DISTINCT or **UNION ALL**

If **UNION ALL** is specified, the result consists of all rows in R1 and R2. With **UNION DISTINCT**, the result is the set of all rows in either R1 or R2 with the redundant duplicate rows eliminated. In either case, each row of the result table of the union is either a row from R1 or a row from R2.

The expression that corresponds to the *n*th column in R1 and R2 can reference columns with column masks. The *n*th column of the result of the union can be derived from the masked values in R1 or R2.

With UNION DISTINCT, the elimination of the duplicate rows is based on the unmasked values in R1 and R2. Because all rows are from R1 or R2, the output values in the result table of the union may vary when one or more of the following conditions occur:

- The expression corresponding to the *n*th column in R1 references columns with column masks, but the expression corresponding to the *n*th column in R2 does not, or vice versa.
- The expressions corresponding to the *n*th column in R1 and R2 reference columns with different column masks.
- The column mask definition references columns that are not the same target column for which the column mask is defined, and those columns are not part of the UNION DISTINCT operation. It is recommended that the column mask definition does not reference other columns from the target table.

For example, a row in R1 is derived from the masked value, and a row in R2 is derived from the unmasked value. If the row in the result table is from R1, the masked value is returned. If the row in the result table is from R2, the unmasked value is returned.

EXCEPT and INTERSECT can be intermixed with UNION if the rows in R1 and R2 for EXCEPT and INTERSECT do not reference columns with column masks.

For compatibility with other SQL implementations, UNIQUE can be specified as a synonym for DISTINCT.

EXCEPT DISTINCT or EXCEPT ALL

If EXCEPT ALL is specified, the result consists of all rows from only R1, including significant redundant duplicate rows. With EXCEPT DISTINCT, the result consists of all rows that are only in R1, with redundant duplicate rows eliminated. In either case, each row in the result table of the difference is a row from R1 that does not have a matching row in R2.

Column masks cannot be applied to the select lists that derive the final result table of set operations if any of the set operators that are used to derive the final result table is EXCEPT ALL or EXCEPT DISTINCT.

For compatibility with other SQL implementations, MINUS can be specified as a synonym for EXCEPT, and UNIQUE can be specified as a synonym for DISTINCT.

INTERSECT DISTINCT or INTERSECT ALL

If INTERSECT ALL is specified, the result consists of all rows that are both in R1 and R2, including significant redundant duplicate rows. With INTERSECT DISTINCT, the result consists of all rows that are in both R1 and R2, with redundant duplicate rows eliminated. In either case each row of the result table of the intersection is a row that exists in both R1 and R2.

Column masks cannot be applied to the select lists that derive the final result table of set operations if any of the set operators that are used to derive the final result table is INTERSECT ALL or INTERSECT DISTINCT.

For compatibility with other SQL implementations, UNIQUE can be specified as a synonym for DISTINCT.

values-clause

Derives a result table by specifying the actual values, using sequence expressions, for each column of a row in the result table.

A *values-clause* is specified by:

- A single sequence expression for a single-column result table.
- *n* sequence expressions, separated by commas and enclosed in parentheses. *n* is the number of columns in the result table.

All result columns in a *values-clause* are unnamed.

values-clause must only be specified in the outer *fullselect* of *select-statement* for a PREPARE statement.

order-by-clause

See “[subselect](#)” on page 1009 for details of the *order-by-clause*. A fullselect that contains an *order-by-clause* cannot be specified in the following contexts:

- The outermost fullselect of a view

Note: An ORDER BY clause in a fullselect might not affect the order of the rows returned by a query. An ORDER BY clause only affects the order of the rows returned in a query if it is specified in the outermost fullselect. An *order-by-clause* should be specified to ensure a predictable order for determining the set of rows from the fullselect if the *offset-clause* or the *fetch-clause* are specified.

- In the outer fullselect in the RETURN statement of an SQL table function.

offset-clause

See “[offset-clause](#)” on page 1046 for details of the *offset-clause*. A fullselect that contains an *offset-clause* cannot be specified in the following contexts:

- The definition of a view
- The definition of a materialized query table
- In the RETURN statement of an SQL table function
- The definition of a row permission
- The definition of a column mask
- The outermost fullselect for a sensitive dynamic cursor

fetch-clause

See “[fetch-clause](#)” on page 1047 for details of the *fetch-clause*. A fullselect that contains a *fetch-clause* cannot be specified in the following contexts:

- The definition of a materialized query table
- The outermost fullselect of the definition of a view
- The outer fullselect in the RETURN statement of an SQL table function
- The outermost fullselect for a sensitive dynamic cursor

Rules for columns

- R1 and R2 must have the same number of columns, and the data type of the *n*th column of R1 must be compatible with the data type of the *n*th column of R2.
- The *n*th column of the result of a set operator is derived from the *n*th columns of R1 and R2. The attributes of the result columns are determined using the rules for result columns.
- R1 and R2 must not include columns having a data type of CLOB, BLOB, DBCLOB, XML, or a distinct type that is based on any of these types. However, this rule is not applicable when UNION ALL is used with the set operator.
- If the *n*th column of R1 and the *n*th column of R2 have the same result column name, the *n*th column of the result table of the set operation has the same result column name. Otherwise, the *n*th column of the result table of the set operation is unnamed.
- Qualified column names cannot be used in the ORDER BY clause when the set operators are specified.

For information on the valid combinations of operand columns and the data type of the result column, see “[Rules for result data types](#)” on page 166.

Duplicate rows

Two rows are duplicates if the value in each column in the first row is equal to the corresponding value of the second row. For determining duplicates, two null values are considered equal.

The DECFLOAT data type allows for multiple bit representations of the same number. For example 2.00 and 2.0 are two numbers with the same coefficient, but different exponent values. See “[Numeric comparisons](#)” on page 156 section for more information. So if the result table of UNION contains a

DECFLOAT column and multiple bit representations of the same number exist, the one returned is unpredictable.

Operator precedence

When multiple set operations are combined in an expression, set operations within parentheses are performed first. If the order is not specified by parentheses, set operations are performed from left to right with the exception that all INTERSECT operations are performed before any UNION or any EXCEPT operations.

Results of set operators

The following table illustrates the results of all set operations, with rows from result table R1 and R2 as the first two columns and the result of each operation on R1 and R2 under the corresponding column heading.

Table 167. Example of UNION, EXCEPT, and INTERSECT set operations on result tables R1 and R2.

Rows in R1	Rows in R2	Result of UNION ALL	Result of UNION DISTINCT	Result of EXCEPT ALL	Result of EXCEPT DISTINCT	Result of INTERSECT ALL	Result of INTERSECT DISTINCT
1	1	1	1	1	2	1	1
1	1	1	2	2	5	1	3
1	3	1	3	2		3	4
2	3	1	4	2		4	
2	3	1	5	4			
2	3	2		5			
3	4	2					
4		2					
4		3					
5		3					
		3					
		3					
		3					
		4					
		4					
		4					
		5					

Examples for fullselect

Example 1

A query specifies the union of result tables R1 and R2. A column in R1 has the data type CHAR(10) and the subtype BIT. The corresponding column in R2 has the data type CHAR(15) and the subtype SBCS. Hence, the column in the union has the data type CHAR(15) and the subtype BIT. Values from the first column are converted to CHAR(15) by adding five trailing blanks.

Example 2

Show all the rows from DSN8C10.EMP.

```
SELECT * FROM DSN8C10.EMP;
```

Example 3

Using sample tables DSN8C10.EMP and DSN8C10.EMPPROJACT, list the employee numbers of all employees for which either of the following statements are true:

- Their department numbers begin with 'D'.
- They are assigned to projects whose project numbers begin with 'AD'.

```
SELECT EMPNO FROM DSN8C10.EMP
WHERE WORKDEPT LIKE 'D%'
UNION
SELECT EMPNO FROM DSN8C10.EMPPROJACT
WHERE PROJNO LIKE 'AD%';
```

The result is the union of two result tables, one formed from the sample table DSN8C10.EMP, the other formed from the sample table DSN8C10.EMPPROJACT. The result—a one-column table—is a list of employee numbers. Because UNION, rather than UNION ALL, was used, the entries in the list are distinct. If instead UNION ALL were used, certain employee numbers would appear in the list more than once. These would be the numbers for employees in departments that begin with 'D' while their projects begin with 'AD'.

Example 4

Specify a series of unions and order the results by the first column of the final result table.

```
SELECT * FROM T1
UNION
SELECT * FROM T2
UNION
SELECT * FROM T3
ORDER BY 1;
```

Example 5

Specify a series of unions and order the results by the first column of the final result table. The first ORDER BY clause order the rows of the result of the first union by the first column of that result table. The second ORDER BY clause is applied as part of the outer fullselect and it causes the rows of the final result table to be ordered by the first column of the final result table.

```
(SELECT * FROM T1
UNION
SELECT * FROM T2
ORDER BY 1)
UNION
SELECT * FROM T3
ORDER BY 1;
```

Example 6

Assume that tables T1 and T2 exist and each contain the same number of columns named C1, C2, and so on. This example of the EXCEPT operator produces all rows that are in T1 but not in T2, with duplicate rows removed:

```
(SELECT * FROM T1)
EXCEPT DISTINCT
(SELECT * FROM T2);
```

Example 7

Assume that tables T1 and T2 exist and each contain the same number of columns named C1, C2, and so on. This example of the INTERSECT operator produces all rows that are in both table T1 and table T2, with duplicate rows removed:

```
(SELECT * FROM T1)
INTERSECT DISTINCT
(SELECT * FROM T2);
```

Example 8

Retrieve the most recently generated value for the sequence MYSEQ1:

```
VALUES PREVIOUS VALUE FOR MYSEQ1;
```

Example 9

Retrieve the next value for the sequence MYSEQ1:

```
VALUES NEXT VALUE FOR MYSEQ1;
```

Related reference

SELECT statement

The *select-statement* is the form of a query that can be directly specified in a DECLARE CURSOR statement, or prepared and then referenced in a DECLARE CURSOR statement. It can also be issued interactively using SPUFI or the command line processor which causes a result table to be displayed at your terminal. In any case, the table specified by *select-statement* is the result of the fullselect.

select-statement

The *select-statement* is the form of a query that can be directly specified in a DECLARE CURSOR statement or FOR statement, prepared and then referenced in a DECLARE CURSOR statement, or directly specified in an SQLJ assignment clause. It can also be issued using SPUFI or the command line processor which causes a result table to be displayed at your terminal. In any case, the result table specified by a *select-statement* is the result of the *fullselect*.

subselect

The *subselect* is a component of the fullselect. A subselect specifies a result table that is derived from the tables or views that are identified in the FROM clause.

Character conversion in set operations and concatenations

The SQL operations that combine strings include concatenation, set operators, and the IN list of an IN predicate. Within an SQL statement, concatenation combines two or more strings into a new string. Within a fullselect, set operation, or the IN list of an IN predicate combine two or more string columns resulting from the subselects into results column.

All such operations have the following in common:

- The choice of a result CCSID for the string or column
- The possible conversion of one or more of the component strings or columns to the result CCSID

For all such operations, the rules for those two actions are the same, as described in [“Selecting the result CCSID”](#) on page 1066. These rules also apply to the COALESCE scalar function.

Selecting the result CCSID

The result CCSID is selected at package prepare time. The result CCSID is the CCSID of one of the operands.

Two operands: When two operands are used, the result CCSID is determined by the operand types, their CCSIDs, and their relative positions in the operation. When a CCSID is X'FFFF', the result CCSID is always X'FFFF', and no character conversions take place. When neither CCSID is X'FFFF', the rules for selecting the result CCSID are identical to the ones for string comparison. See [“Conversion rules for comparisons”](#) on page 159.

Three or more operands:

If all the operands have the same CCSID, the result CCSID is the common CCSID.

If at least one of the CCSIDs has the value X'FFFF', the result CCSID also has the value X'FFFF'.

Otherwise, selection proceeds as follows:

1. The rules for a pair of operands are applied to the first two operands. This picks a "candidate" for the second step. The candidate is the operand that would furnish the result CCSID if just the first two operands were involved in the operation.

2. The rules are applied to the Step 1 candidate and the third operand, thereby selecting a second candidate.
3. If a fourth operand is involved, the rules are applied to the second candidate and fourth operand, to select a third candidate, and so on.

The process continues until all operands have been used. The remaining candidate is the one that furnishes the result CCSID. Whenever the rules for a pair are applied to a candidate and an operand, the candidate is considered to be the first operand.

Consider, for example, the following concatenation:

```
A CONCAT B CONCAT C
```

Here, the rules are first applied to the strings A and B. Suppose that the string selected as candidate is A. Then the rules are applied to A and C. If the string selected is again A, then A furnishes the result CCSID. Otherwise, C furnishes the result CCSID.

Character conversion of components: An operand of concatenation or the selected argument of the COALESCE scalar function is converted, if necessary, to the coded character set of the result string. Each string of an operand of a set operation is converted, if necessary, to the coded character set of the result column. In either case, the coded character set is the one identified by the result CCSID. Character conversion is necessary only if all of the following are true:

- The result and operand CCSIDs are different.
- Neither CCSID is X'FFFF' (neither string is defined as BIT data).
- The string is neither null nor empty.
- The SYSSTRINGS catalog table indicates that conversion is necessary.

An error occurs if a character of a string cannot be converted, SYSSTRINGS is used but contains no information about the CCSID pair, or Db2 cannot do the conversion through z/OS support for Unicode. A warning occurs if a character of a string is converted to the substitution character.

select-statement

The *select-statement* is the form of a query that can be directly specified in a DECLARE CURSOR statement or FOR statement, prepared and then referenced in a DECLARE CURSOR statement, or directly specified in an SQLJ assignment clause. It can also be issued using SPUFI or the command line processor which causes a result table to be displayed at your terminal. In any case, the result table specified by a *select-statement* is the result of the *fullselect*.

Authorization for *select-statement*

See [“Authorization for queries” on page 1007](#).

Syntax for *select-statement*

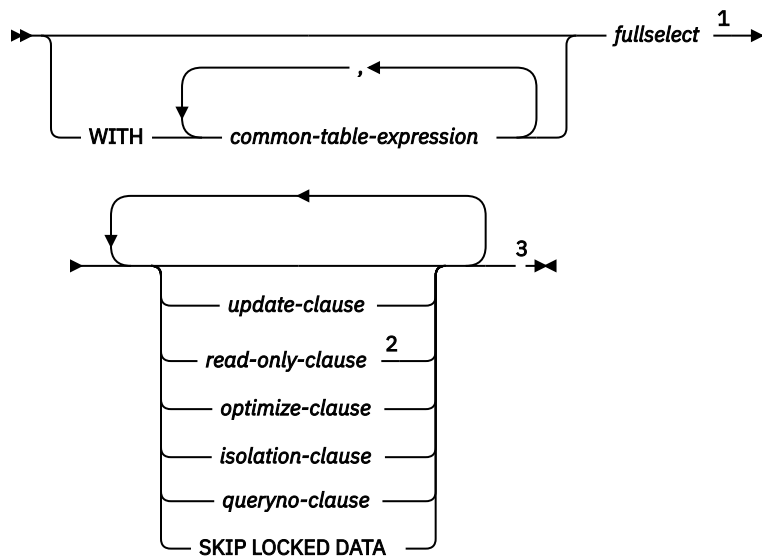

Notes:

- ¹ If *fullselect* is a VALUES clause, *common-table-expression*, *update-clause*, *read-only-clause*, *optimize-clause*, *isolation-clause*, *queryno-clause*, and SKIP LOCKED DATA must not also be specified
- ² The *read-only-clause* must not be specified if *update-clause* is specified.
- ³ The same clause must not be specified more than one time.

The tables and view identified in a select statement can be at the current server or any Db2 subsystem with which the current server can establish a connection.

For local queries on Db2 for z/OS or remote queries in which the server and requester are Db2 for z/OS, if a table is encoded as ASCII or Unicode, the retrieved data is encoded in EBCDIC. For information on retrieving data encoded in ASCII or Unicode, see [Distributed queries against ASCII or Unicode tables \(Db2 Application programming and SQL\)](#).

A select statement can implicitly or explicitly invoke user-defined functions or implicitly invoke stored procedures. This technique is known as *nesting* of SQL statements. A function or procedure is implicitly invoked in a select statement when it is invoked at a lower level. For instance, if you invoke a user-defined function from a select statement and the user-defined function invokes a stored procedure, you are implicitly invoking the stored procedure.

Related reference

[SELECT statement](#)

The *select-statement* is the form of a query that can be directly specified in a DECLARE CURSOR statement, or prepared and then referenced in a DECLARE CURSOR statement. It can also be issued interactively using SPUFI or the command line processor which causes a result table to be displayed at your terminal. In any case, the table specified by *select-statement* is the result of the fullselect.

[fullselect](#)

The fullselect is a component of the *select-statement*, ALTER TABLE statement for the definition of a materialized query table, CREATE TABLE statement, CREATE VIEW statement, DECLARE GLOBAL TEMPORARY TABLE statement, INSERT statement, UPDATE statement, and MERGE statement.

[subselect](#)

The *subselect* is a component of the *fullselect*. A subselect specifies a result table that is derived from the tables or views that are identified in the FROM clause.

common-table-expression

A *common table expression* defines a result table with *table-identifier* that can be referenced in any FROM clause of the *fullselect* that follows.

Multiple common table expressions can be specified following the single WITH keyword. Each specified common table expression can also be referenced by name in the FROM clause of subsequent common table expressions.

common-table-expression

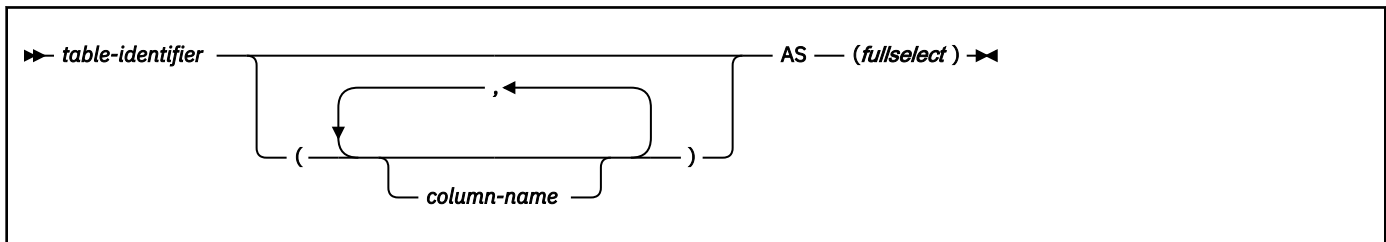

If a list of columns is specified, it must consist of as many names as there are columns in the result table of the *fullselect*. Each *column-name* must be unique and unqualified. If these column names are not specified, the names are derived from the select list of the *fullselect* used to define the common table expression.

table-identifier must be an unqualified SQL identifier, and it must be different from any other *table-identifier* in the same statement. If the common table expression is specified in an INSERT statement, the *table-identifier* must not be the same as the table or view name that is the object of the insert. If the common table expression is specified in a CREATE VIEW statement, the *table-identifier* must not be the same as the view name that is created. A common table expression *table-identifier* can be specified as a table name in any FROM clause throughout the *fullselect*.

If more than one common table expression is defined in the same statement, cyclic references between the common table expressions are not permitted. A *cyclic reference* occurs when two common table expressions *dt1* and *dt2* are created such that *dt1* refers to *dt2* and *dt2* refers to *dt1*. Furthermore, a common table expression defined before cannot refer to subsequent common table expressions.

A common table expression name can only be referenced in the *select-statement*, SELECT INTO statement, INSERT statement, CREATE VIEW statement, or RETURN statement that defines it.

If a *select-statement*, SELECT INTO statement, INSERT statement, or CREATE VIEW statement that is not contained in a trigger definition refers to a unqualified table name, the following rules are applied to determine which table is actually being referenced:

- If the unqualified name corresponds to one or more common table expression names that are specified in the *select-statement*, the name identifies the common table expression that is in the innermost scope.
- Otherwise, the name identifies a persistent table, a temporary table, or a view that is present in the default schema.

If a *select-statement*, SELECT INTO statement, INSERT statement, or CREATE VIEW statement that is contained in a trigger definition refers to a unqualified table name, the following rules are applied to determine which table is actually being referenced:

- If the unqualified name corresponds to one or more common table expression names that are specified in the *select-statement*, the name identifies the common table expression that is in the innermost scope.
- If the unqualified name corresponds to a transition table name, the name identifies that transition table.
- Otherwise, the name identifies a persistent table, a temporary table, or a view that is present in the default schema.

The common table expression is also optional prior to the *fullselect* in the CREATE VIEW and INSERT statements. However, the use of common table expressions is not allowed in a INSERT within SELECT statement.

A common table expression can be used:

- In place of a view to avoid creating the view (when general use of the view is not required and positioned updates or deletes are not used)
- When the result table that you want is based on host variables
- When the same result table needs to be shared in a *fullselect*
- When the result needs to be derived using recursion

If a *fullselect* of a common table expression contains a reference to itself in a FROM clause, the common table expression is a *recursive common table expression*. Queries using recursion are useful in supporting applications such as bill of materials (BOM), reservation systems, and network planning.

The following must be true of a recursive common table expression:

- Each *fullselect* that is part of the recursion cycle must start with SELECT or SELECT ALL. Use of SELECT DISTINCT is not allowed. Furthermore, the set operators must use the ALL keyword.
- The column names must be specified following the *table-name* of the common table expression.
- The first *fullselect* of the first set operator (the initialization *fullselect*) must not include a reference to the common table expression itself in any FROM clause).
- If a column name of the common table expression is referred to in the iterative *fullselect*, the data type, length, and CCSID for the column are determined based on the initialization *fullselect*. The corresponding column in the iterative *fullselect* must have the same data type and length as the data type and length determined based on the initialization *fullselect* and the CCSID must match. However, for character string types, the length of the two data types can differ. In this case, the column in the iterative *fullselect* must have a length that would always be assignable to the length determined from the initialization *fullselect*. If a column of a recursive common table expression is not used recursively in its definition, the data type, length, and CCSID for the column are determined by applying rules associated with non-recursive queries.
- Each *fullselect* that is part of the recursion cycle must not include any aggregate functions, GROUP BY clauses, HAVING clauses, ORDER BY clauses, OFFSET clauses, or FETCH FIRST clauses. The FROM clauses of these *fullselects* can include at most one reference to a common table expression that is part of a recursion cycle.
- Subqueries (scalar or quantified) must not be part of any recursion cycles.
- Outer join must not be part of any recursion cycles.

All columns referenced in a recursive common table expression are nullable for the query, even if they are defined as NOT NULL.

When developing recursive common table expressions, remember that an infinite recursion cycle (loop) can be created. Check that recursion cycles will terminate. This is especially important if the data involved is cyclic. A recursive common table expression is expected to include a predicate that will prevent an infinite loop. The recursive common table expression is expected to include:

- In the iterative *fullselect*, an integer column incremented by a constant.
- A predicate in the WHERE clause of the iterative *fullselect* in the form of "*counter_col* < *constant*" or "*counter_col* < *:hostvar*". A warning is issued if this syntax is not found.

If the result of a recursive common table expression is used to derive the final result table, and if a column mask is used to mask the column values in the final result table, the column mask cannot be applied to a column that is specified in the *fullselect* of the recursive common table expression.

update-clause

The optional FOR UPDATE clause identifies the columns that can appear as targets in an assignment clause in a later positioned UPDATE statement.

update-clause

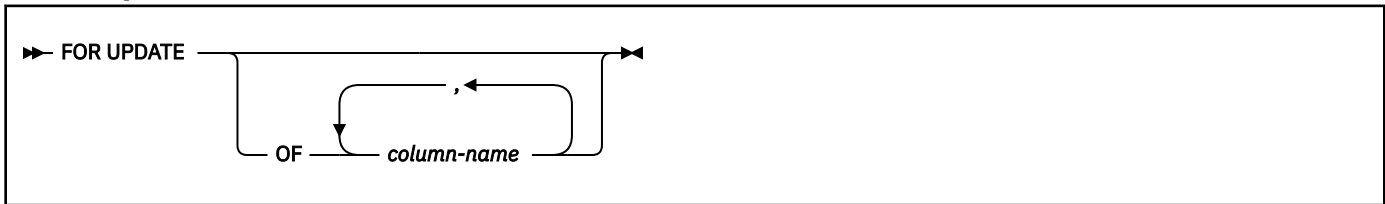

Each column name must be unqualified and must identify a column of the table or view identified in the first FROM clause of the fullselect. The clause must not be specified if the result table of the fullselect is read-only.

If FOR UPDATE clause is specified with a *column-name* list, and extended indicators are not enabled, *column-name* must be an updatable column.

If the FOR UPDATE clause is specified without a *column-name* list, the implicit list of column names consists of all updatable columns of the table or view that is identified in the first FROM clause of the fullselect.

If a dynamically prepared select-statement does not contain a FOR UPDATE clause, the cursor that is associated with the select statement cannot be referenced in a positioned UPDATE statement.

If a statically prepared *select-statement* does not contain a FOR UPDATE clause, and its result table is not read-only, an implicit UPDATE clause will result. The implicit column name list is determine as follows:

- If extended indicators are enabled, all columns of the table or view that is identified in the first FROM clause of the fullselect are included.
- Otherwise, all updatable columns of the table or view that is identified in the first FROM clause of the fullselect are included.

The declaration of a cursor referenced in a positioned UPDATE statement need not include an UPDATE clause if the STDSQL(YES) or NOFOR SQL processing option is specified when the program is prepared. For more information, see [“Positioned updates of columns” on page 326](#).

When FOR UPDATE is used, FETCH operations referencing the cursor acquire U or X locks rather than S locks when:

- The isolation level of the statement is cursor stability.
- The isolation level of the statement is repeatable read or read stability and the RRULOCK subsystem parameter is set to YES.
- The isolation level of the statement is repeatable read or read stability and USE AND KEEP EXCLUSIVE LOCKS or USE AND KEEP UPDATE LOCKS is specified in the SQL statement, an X lock or a U lock, respectively, is acquired at fetch time.

No locks are acquired on declared temporary tables. For a discussion of U locks and S locks, see [Lock modes and compatibility of locks \(Db2 Performance\)](#).

Notes

Referencing columns that will be updated:

If a cursor uses FETCH statements to retrieve columns that will be updated later, specify FOR UPDATE OF when you select the columns. Then specify WHERE CURRENT OF in the subsequent UPDATE or DELETE statements. These clauses prevent Db2 from selecting access through an index on the columns that are being updated, which might otherwise cause Db2 to read the same row more than once.

For more information, see [Updating previously retrieved data \(Db2 Application programming and SQL\)](#).

Related tasks

[Updating previously retrieved data \(Db2 Application programming and SQL\)](#)

Related reference

[U LOCK FOR RR/RS field \(RRULOCK subsystem parameter\) \(Db2 Installation and Migration\)](#)

read-only-clause

The read-only clause specifies that the result table is read-only. Therefore, the cursor cannot be referred to in positioned UPDATE or DELETE statements.

read-only-clause

►► FOR READ ONLY ◄◄

Some result tables are read-only by nature (for example, a table based on a read-only view.) FOR READ ONLY can still be specified for such tables, but the specification has no effect.

For tables in which updates and deletes are allowed, specifying FOR READ ONLY can possibly improve the performance of FETCH operations as Db2 can do blocking and avoid exclusive locks. For example, in programs that contain dynamic SQL statements without the FOR READ ONLY or ORDER BY clause, Db2 might open cursors as if the UPDATE clause was specified.

A read-only result table must not be referred to in an UPDATE or DELETE statement, whether it is read-only by nature or specified as FOR READ ONLY.

To take advantage of the possibly improved performance of FETCH operations while guaranteeing that selected data is not modified and preventing some types of deadlocks, you can specify FOR READ ONLY in combination with the optional syntax of USE AND KEEP ... LOCKS on the *isolation-clause*.

Alternative syntax and synonyms: FOR FETCH ONLY can be specified as a synonym for FOR READ ONLY.

Related concepts

[Block fetch \(Introduction to Db2 for z/OS\)](#)

[Problems with ambiguous cursors \(Db2 Performance\)](#)

Related tasks

[Enabling block fetch for distributed applications \(Db2 Performance\)](#)

Related reference

[FETCH statement](#)

The FETCH statement positions a cursor on a row of its result table. It can return zero, one, or multiple rows and assigns the values of the rows to variables if there is a target specification.

[UPDATE statement](#)

The UPDATE statement updates the values of specified columns in rows of a table or view. Updating a row of a view updates a row of its base table if no INSTEAD OF UPDATE trigger is defined for this view. If such a trigger is defined, the trigger is activated instead.

[DELETE statement](#)

The DELETE statement deletes rows from a table or view. Deleting a row from a view deletes the row from the table on which the view is based if no INSTEAD OF DELETE trigger is defined for this view. If such a trigger is defined, the trigger is activated instead.

[isolation-clause](#)

The *isolation-clause* specifies the isolation level at which the statement is executed. (Isolation level does not apply to declared temporary tables because no locks are acquired.)

optimize-clause

The OPTIMIZE clause requests special optimization of the *select-statement*.

optimize-clause

►► OPTIMIZE FOR — *integer* — ROWS
 ROW

The *optimize-clause* tells Db2 to assume that the program does not intend to retrieve more than *integer* rows from the result table. Without this clause, Db2 assumes that all rows of the result table will be retrieved, unless the FETCH FIRST clause is specified. Optimizing for *integer* rows can improve performance. If this clause is omitted and the FETCH FIRST is specified, OPTIMIZE FOR *integer* ROWS is assumed, where *integer* is the value that is specified in the FETCH FIRST clause. Db2 will optimize the query based on the specified number of rows.

The clause does not limit the number of rows that can be fetched, change the result table, or change the order in which the rows are fetched. Any number of rows can be fetched, but performance can possibly degrade after *integer* fetches. In general, if you are retrieving only a few rows, specify OPTIMIZE FOR 1 ROW to influence the access path that Db2 selects.

The value of *integer* must be a positive integer (not zero).

Row access controls indirectly affects the OPTIMIZE FOR clause because row access controls affect the rows that are accessible to the authorization ID or role of the subselect.

Column access controls do not affect the OPTIMIZE FOR clause.

If the *optimize-clause* is not specified, a default of OPTIMIZE FOR *integer* ROWS, *integer* is determined from the following table. The Db2 subsystem uses this value for access path optimization.

Table 168. Determination of integer for OPTIMIZE clause

OFFSET <i>m</i> ROWS	FETCH FIRST <i>n</i> ROWS ONLY	OPTIMIZE FOR <i>o</i> ROWS	
		Specified	Not Specified
constant	constant	<i>o</i>	<i>m+n</i>
Not specified	constant	<i>o</i>	<i>n</i>
All other combinations of OFFSET and FETCH FIRST clauses		<i>o</i>	All rows

Related tasks

[Minimizing the cost of retrieving few rows \(Db2 Performance\)](#)

[Optimizing retrieval for a small set of rows \(Db2 Application programming and SQL\)](#)

isolation-clause

The *isolation-clause* specifies the isolation level at which the statement is executed. (Isolation level does not apply to declared temporary tables because no locks are acquired.)

isolation-clause

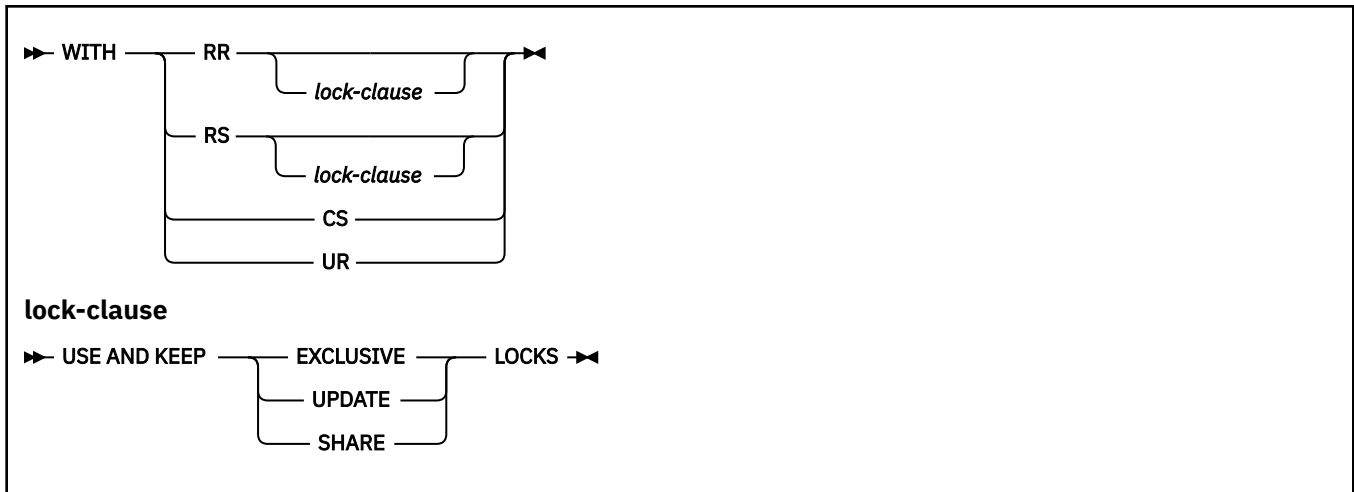

RR

Repeatable read

RR lock-clause

Repeatable read, using and keeping the type of lock that is specified in *lock-clause* on all accessed pages and rows

RS

Read stability

RS lock-clause

Read stability, using and keeping the type of lock that is specified in *lock-clause* on all accessed pages and rows

CS

Cursor stability

UR

Uncommitted read

lock-clause

Specifies the type of lock.

USE AND KEEP EXCLUSIVE LOCKS

USE AND KEEP UPDATE LOCKS

USE AND KEEP SHARE LOCKS

Specifies that Db2 is to acquire and hold X, U, or S locks, respectively.

WITH UR can be specified only if the result table of the fullselect or the SELECT INTO statement is read-only.

In an ODBC application, the SQLSetStmtAttr function can be used to set statement attributes that interact with the *lock-clause*. If SQLSetStmtAttr is invoked with a cursor's statement handle and specifying that its SQL_ATTR_CLOSE_BEHAVIOR is SQL_CC_RELEASE (locks are to be released when the cursor is closed), then irrespective of any *lock-clause*, lock used by the cursor that are not needed to protect the integrity of changed data are released..

Although requesting an UPDATE or EXCLUSIVE LOCK can reduce concurrency, it can prevent some types of deadlocks.

The **default** isolation level of the statement depends on:

- The isolation of the package or plan that the statement is bound in
- Whether the result table is read-only

Table 169 on page 1075 shows the default isolation level of the statement.

Table 169. Default isolation level based on the isolation level of the package or plan and whether the result table is read-only

If package isolation is:	And plan isolation is:	And the result table is:	Then the default isolation is:	
RR	Any	Any	RR	
RS	Any	Any	RS	
CS	Any	Any	CS	
UR	Any	Read-only	UR	
		Not read-only	CS	
Not specified	Not specified	Any	RR	
	RR	Any	RR	
	RS	Any	RS	
	CS	Any	CS	
	UR	UR	Read-only	UR
			Not read-only	CS

A simple way to ensure that a result table is read-only is to specify FOR READ ONLY in the SQL statement.

Alternative syntax and synonyms: KEEP UPDATE LOCKS can be specified as a synonym for USE AND KEEP EXCLUSIVE LOCKS. However, KEEP UPDATE LOCKS can be specified only if FOR UPDATE OF is specified, and it is not supported in the SELECT INTO statement.

Related concepts

[Lock modes and compatibility of locks \(Db2 Performance\)](#)

Related tasks

[Choosing an ISOLATION option \(Db2 Performance\)](#)

[Programming for concurrency \(Db2 Performance\)](#)

Related reference

[SQLSetStmtAttr\(\) - Set statement attributes \(Db2 Programming for ODBC\)](#)

queryno-clause

The QUERYNO clause specifies the number to be used for this SQL statement in EXPLAIN output and trace records. The number is used for the QUERYNO columns of the plan tables for the rows that contain information about this SQL statement. This number is also used in the QUERYNO column of the SYSIBM.SYSTMT and SYSIBM.SYSPACKSTMT catalog tables.

queryno-clause

►► QUERYNO — *integer* ◄◄

integer is the value to be used to identify this SQL statement in EXPLAIN output and trace records.

If the clause is omitted, the number associated with the SQL statement is the statement number assigned during precompilation. Thus, if the application program is changed and then precompiled, that statement number might change.

Using the QUERYNO clause to assign unique numbers to the SQL statements in a program is helpful:

- For simplifying the use of optimization hints for access path selection
- For correlating SQL statement text with EXPLAIN output in the plan table

For more information about using and enabling optimization hints, see [Influencing access path selection \(Db2 Performance\)](#)

For information on accessing the plan table, see [Investigating SQL performance by using EXPLAIN \(Db2 Performance\)](#).

SKIP LOCKED DATA

The SKIP LOCKED DATA clause specifies that rows are skipped when incompatible locks that would block the progress of the statement are held on the rows by other transactions. These rows can belong to any accessed table that is specified in the statement. SKIP LOCKED DATA can be used only with isolation CS or RS and applies only to row level or page level locks.

► SKIP LOCKED DATA ◄

Important: The recommendation is to not rely on the SKIP LOCKED DATA option to remove rows from results returned by a query. The SKIP LOCKED DATA option is meant only to prevent possibly incompatible locks from impeding the progress of queries that can tolerate possibly incomplete results. However, Db2 might use lock avoidance techniques to avoid taking certain locks.

SKIP LOCKED DATA is ignored if it is specified when the isolation level that is in effect is repeatable read (WITH RR) or uncommitted read (WITH UR). The default isolation level of the statement depends on the isolation level of the package or plan with which the statement is bound, and whether the result table is read-only.

Related concepts

[Lock avoidance \(Db2 Performance\)](#)

Related tasks

[Improving concurrency for applications that tolerate incomplete results \(Db2 Performance\)](#)

Related reference

[select-statement](#)

The *select-statement* is the form of a query that can be directly specified in a DECLARE CURSOR statement or FOR statement, prepared and then referenced in a DECLARE CURSOR statement, or directly specified in an SQLJ assignment clause. It can also be issued using SPUFI or the command line processor which causes a result table to be displayed at your terminal. In any case, the result table specified by a *select-statement* is the result of the *fullselect*.

[SELECT INTO statement](#)

The SELECT INTO statement produces a result table that contains at most one row. The statement assigns the values in that row to variables. If the table is empty, the statement does not assign values to the host variables or global variables.

[UPDATE statement](#)

The UPDATE statement updates the values of specified columns in rows of a table or view. Updating a row of a view updates a row of its base table if no INSTEAD OF UPDATE trigger is defined for this view. If such a trigger is defined, the trigger is activated instead.

[DELETE statement](#)

The DELETE statement deletes rows from a table or view. Deleting a row from a view deletes the row from the table on which the view is based if no INSTEAD OF DELETE trigger is defined for this view. If such a trigger is defined, the trigger is activated instead.

[PREPARE statement](#)

The PREPARE statement creates an executable SQL statement from a string form of the statement. The character-string form is called a *statement string*. The executable form is called a *prepared statement*.

Examples of SELECT statements

Examples of SELECT statements.

Introductory concepts

[How a SELECT statement works \(Introduction to Db2 for z/OS\)](#)

Example 1: Select all the rows from DSN8C10.EMP.

```
SELECT * FROM DSN8C10.EMP;
```

Example 2: Select all the rows from DSN8C10.EMP, arranging the result table in chronological order by date of hiring.

```
SELECT * FROM DSN8C10.EMP  
ORDER BY HIREDATE;
```

Example 3: Select the department number (WORKDEPT) and average departmental salary (SALARY) for all departments in the table DSN8C10.EMP. Arrange the result table in ascending order by average departmental salary.

```
SELECT WORKDEPT, AVG(SALARY)  
FROM DSN8C10.EMP  
GROUP BY WORKDEPT  
ORDER BY 2;
```

Example 4: Change various salaries, bonuses, and commissions in the table DSN8C10.EMP. Confine the changes to employees in departments D11 and D21. Use positioned updates to do this with a cursor named UP_CUR. Use a FOR UPDATE clause in the cursor declaration to indicate that all updatable columns are updated. Below is the declaration for a PL/I program.

```
EXEC SQL DECLARE UP_CUR CURSOR FOR  
SELECT WORKDEPT, EMPNO, SALARY, BONUS, COMM  
FROM DSN8C10.EMP  
WHERE WORKDEPT IN ('D11', 'D21')  
FOR UPDATE;
```

Beginning where the cursor is declared, all updatable columns would be updated. If only specific columns needed to be updated, such as only the salary column, the FOR UPDATE clause could be used to specify the salary column (FOR UPDATE OF SALARY).

Example 5: Find the maximum, minimum, and average bonus in the table DSN8C10.EMP. Execute the statement with uncommitted read isolation, regardless of the value of ISOLATION with which the plan or package containing the statement is bound. Assign 13 as the query number for the SELECT statement.

```
EXEC SQL  
SELECT MAX(BONUS), MIN(BONUS), AVG(BONUS)  
INTO :MAX, :MIN, :AVG  
FROM DSN8C10.EMP  
WITH UR  
QUERYNO 13;
```

If bind option EXPLAIN(YES) is specified, rows are inserted into the plan table. The value used for the QUERYNO column for these rows is 13.

Example 6: The cursor declaration shown below is in a PL/I program. In the query within the declaration, X.RMT_TAB is an alias for a table at some other Db2. Hence, when the query is used, it is processed using DRDA access. See [Distributed relational databases \(Introduction to Db2 for z/OS\)](#).

The declaration indicates that no positioned updates or deletes will be done with the query's cursor. It also specifies that the access path for the query be optimized for the retrieval of at most 50 rows. Even so, the program can retrieve more than 50 rows from the result table, which consists of the entire

table identified by the alias. However, when more than 50 rows are retrieved, performance could possibly degrade.

```
EXEC SQL DECLARE C1 CURSOR FOR
  SELECT * FROM X.RMT_TAB
  OPTIMIZE FOR 50 ROWS
  FOR READ ONLY;
```

The FETCH FIRST clause could be used instead of the OPTIMIZE FOR clause to ensure that only 50 rows are retrieved as in the following example:

```
EXEC SQL DECLARE C1 CURSOR FOR
  SELECT * FROM X.RMT_TAB
  FETCH FIRST 50 ROWS ONLY;
```

Example 7: Assume that table DSN8C10.EMP has 1000 rows and you want to see the first five EMP_ROWID values that were inserted into DSN8C10.EMP_PHOTO_RESUME.

```
EXEC SQL DECLARE CS1 CURSOR FOR
  SELECT EMP_ROWID
  FROM FINAL TABLE (INSERT INTO DSN8C10.EMP_PHOTO_RESUME (EMPNO)
  SELECT EMPNO FROM DSN8C10.EMP)
  FETCH FIRST 5 ROWS ONLY;
```

All 1000 rows are inserted into DSN8C10.EMP_PHOTO_RESUME, but only the first five are returned.

Related tasks

[Coding SQL statements to avoid unnecessary processing \(Db2 Performance\)](#)

[Retrieving data by using the SELECT statement \(Db2 Application programming and SQL\)](#)

Chapter 7. Statements

This section contains syntax diagrams, semantic descriptions, rules, and examples of the use of the SQL statements.

For similar information about the use of SQL procedure language (SQL PL) statements, see [Chapter 8, “SQL procedural language \(SQL PL\),”](#) on page 2207.

List of supported statements

This section contains an alphabetical list of the SQL statements that Db2 for z/OS supports.

Table 170. Supported SQL statements

SQL statement	Function
“ALLOCATE CURSOR statement” on page 1093	Defines and associates a cursor with a result set locator variable
“ALTER DATABASE statement” on page 1095	Changes the description of a database
“ALTER FUNCTION statement (external function)” on page 1097	Changes the description of a user-defined external scalar or external table function
“ALTER FUNCTION statement (compiled SQL scalar function)” on page 1113	Changes the description of a compiled SQL scalar function
“ALTER FUNCTION statement (inlined SQL scalar function)” on page 1142	Changes the description of an inlined SQL scalar function
“ALTER FUNCTION statement (SQL table function)” on page 1150	Changes the description of an SQL table function
“ALTER INDEX statement” on page 1157	Changes the description of an index
“ALTER MASK statement” on page 1174	Changes the description of a column mask
“ALTER PERMISSION statement” on page 1177	Changes the description of a row permission
“ALTER PROCEDURE statement (external procedure)” on page 1180	Changes the description of an external procedure
“ALTER PROCEDURE statement (SQL - external procedure) (deprecated)” on page 1189	Changes the description of an external SQL procedure
“ALTER PROCEDURE statement (SQL - native procedure)” on page 1194	Changes the description of or defines additional versions for a native SQL procedure
“ALTER SEQUENCE statement” on page 1224	Changes the description of a sequence
“ALTER STOGROUP statement” on page 1228	Changes the description of a storage group

Table 170. Supported SQL statements (continued)

SQL statement	Function
“ALTER TABLE statement” on page 1232	Changes the description of a table
“ALTER TABLESPACE statement” on page 1321	Changes the description of a table space
“ALTER TRIGGER statement (advanced trigger)” on page 1342	Changes the description of an advanced trigger
“ALTER TRIGGER statement (basic trigger)” on page 1365	Changes the description of a basic trigger
“ALTER TRUSTED CONTEXT statement” on page 1368	Changes the description of a trusted context
“ALTER VIEW statement” on page 1378	Regenerates a view
“ASSOCIATE LOCATORS statement” on page 1380	Gets the result set locator value for each result set returned by a stored procedure
“BEGIN DECLARE SECTION statement” on page 1383	Marks the beginning of a host variable declaration section
“CALL statement” on page 1384	Calls a stored procedure
“CLOSE statement” on page 1395	Closes a cursor
“COMMENT statement” on page 1396	Adds or replaces a comment to the description of an object
“COMMIT statement” on page 1406	Ends a unit of recovery and commits the database changes made by that unit of recovery
“CONNECT statement” on page 1409	Connects the process to a server
“CREATE ALIAS statement” on page 1415	Defines an alias
“CREATE AUXILIARY TABLE statement” on page 1418	Defines an auxiliary table for storing LOB data
“CREATE DATABASE statement” on page 1421	Defines a database
“CREATE FUNCTION statement (compiled SQL scalar function)” on page 1428	Defines a compiled SQL scalar function
“CREATE FUNCTION statement (external scalar function)” on page 1453	Defines a user-defined external scalar function
“CREATE FUNCTION statement (external table function)” on page 1472	Defines a user-defined external table function
“CREATE FUNCTION statement (inlined SQL scalar function)” on page 1489	Defines an inlined SQL scalar function

Table 170. Supported SQL statements (continued)

SQL statement	Function
“CREATE FUNCTION statement (sourced function)” on page 1498	Defines a user-defined function that is based on an existing scalar or aggregate function
“CREATE FUNCTION statement (SQL table function)” on page 1510	Defines a user-defined SQL table function
“CREATE GLOBAL TEMPORARY TABLE statement” on page 1518	Defines a created temporary table
“CREATE INDEX statement” on page 1524	Defines an index on a table
“CREATE LOB TABLESPACE” on page 1553	Defines a LOB table space
“CREATE MASK statement” on page 1562	Defines a column mask
“CREATE PERMISSION statement” on page 1571	Defines a row permission
“CREATE PROCEDURE statement (external procedure)” on page 1580	Defines an external stored procedure
“CREATE PROCEDURE statement (SQL - external procedure) (deprecated)” on page 1597	Defines an external SQL procedure
“CREATE PROCEDURE statement (SQL - native procedure)” on page 1607	Defines a native SQL procedure
“CREATE ROLE statement” on page 1637	Defines a role
“CREATE SEQUENCE statement” on page 1638	Defines a sequence
“CREATE STOGROUP statement” on page 1645	Defines a storage group
“CREATE SYNONYM statement (unsupported)” on page 1649	Defines an alternative name for a table or view
“CREATE TABLE statement” on page 1650	Defines a table
“CREATE TABLESPACE statement” on page 1718	Defines a table space, which includes allocating and formatting the table space
“CREATE TRIGGER statement (advanced trigger)” on page 1740	Defines an advanced trigger
“CREATE TRIGGER statement (basic trigger)” on page 1769	Defines a basic trigger
“CREATE TRUSTED CONTEXT statement” on page 1787	Defines a trusted context
“CREATE TYPE statement (array type)” on page 1795	Defines an array type

Table 170. Supported SQL statements (continued)

SQL statement	Function
“CREATE TYPE statement (distinct type)” on page 1801	Defines a distinct type
“CREATE VARIABLE statement” on page 1808	Defines a global variable
“CREATE VIEW statement” on page 1812	Defines a view of one or more tables or views
“DECLARE CURSOR statement” on page 1819	Defines an SQL cursor
“DECLARE GLOBAL TEMPORARY TABLE statement” on page 1830	Defines a declared temporary table
“DECLARE STATEMENT statement” on page 1844	Declares names used to identify prepared SQL statements
“DECLARE TABLE statement” on page 1845	Provides the programmer and the precompiler with a description of a table or view
“DECLARE VARIABLE statement” on page 1850	Defines a CCSID for a host variable
“DELETE statement” on page 1853	Deletes one or more rows from a table
“DESCRIBE CURSOR statement” on page 1869	Puts information about the result set associated with a cursor into a descriptor
“DESCRIBE INPUT statement” on page 1871	Puts information about the input parameter markers of a prepared statement into a descriptor
“DESCRIBE OUTPUT statement” on page 1873	Describes the result columns of a prepared statement
“DESCRIBE PROCEDURE statement” on page 1879	Puts information about the result sets returned by a stored procedure into a descriptor
“DESCRIBE TABLE statement” on page 1881	Describes the columns of a table or view
“DROP statement” on page 1886	Removes an object at the current server. Except for storage groups, any objects that are directly or indirectly dependent on that object are also removed.
“END DECLARE SECTION statement” on page 1907	Marks the end of a host variable declaration section
“EXCHANGE statement” on page 1908	Exchanges data between the specified base table and an associated clone table
EXECUTE	Executes a prepared SQL statement
“EXECUTE IMMEDIATE statement” on page 1914	Prepares and executes an SQL statement
“EXPLAIN statement” on page 1917	Obtains information about how an SQL statement would be executed
“FETCH statement” on page 1924	Positions the cursor, returns data, or both positions the cursor and returns data

Table 170. Supported SQL statements (continued)

SQL statement	Function
“FREE LOCATOR statement” on page 1949	Removes the association between a LOB locator variable and its value
“GET DIAGNOSTICS statement” on page 1949	Provides diagnostic information about the last SQL statement that was executed
“GRANT statement” on page 1963	Grants privileges to authorization IDs
“GRANT statement (collection privileges)” on page 1967	Grants authority to create a package in a collection
“GRANT statement (database privileges)” on page 1968	Grants privileges on a database
“GRANT statement (function or procedure privileges)” on page 1970	Grants privileges on a user-defined function or a stored procedure
“GRANT statement (package privileges)” on page 1975	Grants authority to bind, execute, or copy a package
“GRANT statement (plan privileges)” on page 1977	Grants authority to bind or execute an application plan
“GRANT statement (schema privileges)” on page 1978	Grants privileges on a schema
“GRANT statement (sequence privileges)” on page 1979	Grants privileges on a user-defined sequence
“GRANT statement (system privileges)” on page 1981	Grants system privileges
“GRANT statement (table or view privileges)” on page 1988	Grants privileges on a table or view
“GRANT statement (type or JAR file privileges)” on page 1991	Grants privileges to use distinct types, array types, or JAR files
“GRANT statement (variable privileges)” on page 1992	Grants privileges on global variables
“GRANT statement (use privileges)” on page 1993	Grants authority to use specified buffer pools, storage groups, or table spaces
“HOLD LOCATOR statement” on page 1994	Allows a LOB locator variable to retain its association with its value beyond a unit of work
“INCLUDE statement” on page 1995	Inserts declarations into a source program
“INSERT statement” on page 1996	Inserts one or more rows into a table
“LABEL statement” on page 2015	Adds or replaces a label on the description of a table, view, alias, or column
“LOCK TABLE statement” on page 2017	Locks a table or table space partition in shared or exclusive mode
“MERGE statement” on page 2019	Updates a target (a table or view) using data from a source (result of VALUES clause or table reference)
“OPEN statement” on page 2037	Opens a cursor

Table 170. Supported SQL statements (continued)

SQL statement	Function
“PREPARE statement” on page 2042	Prepares an SQL statement (with optional parameters) for execution
“REFRESH TABLE statement” on page 2062	Refreshes the data in a materialized query table
“RELEASE statement (connection)” on page 2063	Places one or more connections in the release pending status
“RELEASE SAVEPOINT statement” on page 2065	Releases a savepoint and any subsequently set savepoints within a unit of recovery
“RENAME statement” on page 2066	Renames an existing table or index
“REVOKE statement” on page 2070	Revokes privileges from authorization IDs
“REVOKE statement (collection privileges)” on page 2076	Revokes authority to create a package in a collection
“REVOKE statement (database privileges)” on page 2078	Revokes privileges on a database
“REVOKE statement (function or procedure privileges)” on page 2081	Revokes privileges on a user-defined function or a stored procedure
“REVOKE statement (package privileges)” on page 2087	Revokes authority to bind, execute, or copy a package
“REVOKE statement (plan privileges)” on page 2089	Revokes authority to bind or execute an application plan
“REVOKE statement (schema privileges)” on page 2091	Revokes privileges on a schema
“REVOKE statement (sequence privileges)” on page 2093	Revokes privileges on a user-defined sequence
“REVOKE statement (system privileges)” on page 2095	Revokes system privileges
“REVOKE statement (table or view privileges)” on page 2101	Revokes privileges on a table or view
“REVOKE (type or JAR file privileges)” on page 2104	Revokes privileges on a user-defined data type or a JAR file
“REVOKE (variable privileges)” on page 2106	Revokes privileges on global variables
“REVOKE statement (use privileges)” on page 2108	Revokes authority to use specified buffer pools, storage groups, or table spaces
“ROLLBACK statement” on page 2110	Ends a unit of recovery and backs out the changes to the database made by that unit of recovery, or partially rolls back the changes to a savepoint within the unit of recovery
“SAVEPOINT statement” on page 2113	Sets a savepoint within a unit of recovery
“SELECT statement” on page 2114	Specifies the SELECT statement of the cursor
“SELECT INTO statement” on page 2117	Specifies a result table of no more than one row and assigns the values to variables

Table 170. Supported SQL statements (continued)

SQL statement	Function
“SET CONNECTION statement” on page 2122	Establishes the database server of the process by identifying one of its existing connections
“SET assignment-statement statement” on page 2124	Assigns values to variables and array elements
“SET CURRENT ACCELERATOR statement” on page 2129	Assigns a value to the CURRENT ACCELERATOR special register
“SET CURRENT APPLICATION COMPATIBILITY statement” on page 2130	Assigns a value to the CURRENT APPLICATION COMPATIBILITY special register
“SET CURRENT APPLICATION ENCODING SCHEME” on page 2132	Assigns a value to the CURRENT APPLICATION ENCODING SCHEME special register
“SET CURRENT DEBUG MODE statement” on page 2133	Assigns a value to the CURRENT DEBUG MODE special register
“SET CURRENT DECFLOAT ROUNDING MODE statement” on page 2134	Assigns a value to the CURRENT DECFLOAT ROUNDING MODE special register
“SET CURRENT DEGREE statement” on page 2136	Assigns a value to the CURRENT DEGREE special register
“SET CURRENT EXPLAIN MODE statement” on page 2137	Assigns a value to the CURRENT EXPLAIN MODE special register
“SET CURRENT GET_ACCEL_ARCHIVE statement” on page 2138	Assigns a value to the CURRENT GET_ACCEL_ARCHIVE special register
“SET CURRENT LOCALE LC_CTYPE statement” on page 2139	Assigns a value to the CURRENT LOCALE LC_CTYPE special register
“SET CURRENT MAINTAINED TABLE TYPES FOR OPTIMIZATION statement” on page 2141	Assigns a value to the CURRENT MAINTAINED TABLE TYPES FOR OPTIMIZATION special register
“SET CURRENT OPTIMIZATION HINT statement” on page 2142	Assigns a value to the CURRENT OPTIMIZATION HINT special register
“SET CURRENT PACKAGE PATH statement” on page 2143	Assigns a value to the CURRENT PACKAGE PATH special register
“SET CURRENT PACKAGESET statement” on page 2146	Assigns a value to the CURRENT PACKAGESET special register
“SET CURRENT PRECISION statement” on page 2148	Assigns a value to the CURRENT PRECISION special register
“SET CURRENT QUERY ACCELERATION statement” on page 2148	Assigns a value to the CURRENT QUERY ACCELERATION special register
“SET CURRENT QUERY ACCELERATION WAITFORDATA statement” on page 2150	Assigns a value to the CURRENT QUERY ACCELERATION WAITFORDATA special register

Table 170. Supported SQL statements (continued)

SQL statement	Function
“SET CURRENT REFRESH AGE statement” on page 2153	Assigns a value to the CURRENT REFRESH AGE special register
“SET CURRENT ROUTINE VERSION statement” on page 2154	Assigns a value to the CURRENT ROUTINE VERSION special register
“SET CURRENT RULES statement” on page 2156	Assigns a value to the CURRENT RULES special register
“SET CURRENT SQLID statement” on page 2156	Assigns a value to the CURRENT SQLID special register
“SET CURRENT TEMPORAL BUSINESS_TIME statement” on page 2158	Assigns a value to the CURRENT TEMPORAL BUSINESS_TIME special register
“SET CURRENT TEMPORAL SYSTEM_TIME statement” on page 2160	Assigns a value to the CURRENT TEMPORAL SYSTEM_TIME special register
“SET ENCRYPTION PASSWORD statement” on page 2161	Assigns a value for the ENCRYPTION PASSWORD and an optional hint for the password
“SET PATH statement” on page 2163	Assigns a value to the CURRENT PATH special register
“SET SCHEMA statement” on page 2166	Assigns a value to the CURRENT SCHEMA special register
“SET SESSION TIME ZONE statement” on page 2168	Assigns a value to the CURRENT SESSION TIME ZONE special register
SIGNAL	Signals an error or warning condition and optionally returns the specified message text
“TRANSFER OWNERSHIP statement” on page 2172	Transfers ownership of a database or system object from one owner to another
“TRUNCATE statement” on page 2175	Deletes all rows from a base table or declared temporary table
“UPDATE statement” on page 2178	Updates the values of one or more columns in one or more rows of a table
“VALUES statement” on page 2199	Provides a way to invoke a user-defined function from a trigger
“VALUES INTO statement” on page 2200	Assigns values to variables
“WHENEVER statement” on page 2204	Defines actions to be taken on the basis of SQL return codes

How SQL statements are invoked

SQL statements are invoked in different ways depending on whether the statement is an executable or nonexecutable statement or the *select-statement*.

The SQL statements are classified as *executable* or *nonexecutable*. The description of each statement includes a heading on invocation that indicates whether or not the statement is executable.

Executable statements can be invoked in the following ways:

- Embedded in an application program
- Dynamically prepared and executed
- Dynamically prepared and executed using Db2 ODBC function calls
- Issued interactively

Depending on the statement, you can use some or all of these methods. The section on invocation in the description of each statement tells you which methods can be used.

A *nonexecutable statement* can only be embedded in an application program.

The *select-statement* is an additional SQL statement construct. (See [“select-statement” on page 1067.](#)) It is used in a different way from other statements.

A *select-statement* can be invoked in the following ways:

- Included in DECLARE CURSOR and implicitly executed by OPEN
- Dynamically prepared, referred to in DECLARE CURSOR, and implicitly executed by OPEN
- Dynamically executed (no PREPARE required) using a Db2 ODBC function call
- Issued interactively

The first two methods are called, respectively, the *static* and the *dynamic* invocation of *select-statement*.

Related concepts

[Submitting SQL statements to Db2 \(Introduction to Db2 for z/OS\)](#)

[The Db2 command line processor \(Db2 Commands\)](#)

Related tasks

[Executing SQL by using SPUFI \(Db2 Application programming and SQL\)](#)

[Overview of programming applications that access Db2 for z/OS data \(Db2 Application programming and SQL\)](#)

Embedding a statement in an application program

You can include SQL statements in a source program that will be submitted to the Db2 precompiler or coprocessor. Such statements are said to be *embedded* in the application program. An embedded statement can be placed anywhere in the application program where a host language statement is allowed. Each embedded statement must be preceded by a keyword (or keywords) to indicate that the statement is an SQL statement.

- In C and COBOL, each embedded statement must be preceded by the keywords EXEC SQL.
- In Java, each embedded statement must be preceded by the keywords #sql.
- In REXX, each embedded statement must be preceded by the keyword EXECSQL.

Executable statements: An executable statement embedded in an application program is executed every time a statement of the host language would be executed if specified in the same place. (Thus, for example, a statement within a loop is executed every time the loop is executed, and a statement within a conditional construct is executed only when the condition is satisfied.)

An embedded statement can contain references to host variables. A host variable referred to in this way can be used in one of two ways:

As input

The current value of the host variable is used in the execution of the statement.

As output

The variable is assigned a new value as a result of executing the statement.

In particular, all references to host variables in expressions and predicates are effectively replaced by current values of the variables; that is, the variables are used as input. The treatment of other references is described individually for each statement.

The successful or unsuccessful execution of the statement is indicated by setting the SQLCODE and SQLSTATE fields in the SQLCA.²³ You must therefore follow all executable statements by a test of SQLCODE or SQLSTATE. Alternatively, you can use the WHENEVER statement (which is itself nonexecutable) to change the flow of control immediately after the execution of an embedded statement.

Nonexecutable statements: An embedded nonexecutable statement is processed only by the precompiler or coprocessor. The precompiler or coprocessor reports any errors encountered in the statement. The statement is never executed, and acts as a no-operation if placed among executable statements of the application program. Therefore, do not follow such statements with a test of an SQL return code.

Dynamic preparation and execution

Your application program can dynamically build an SQL statement in the form of a character string placed in a host variable. In general, the statement is built from some data available to the application program (for example, input from a workstation).

In non-Java languages, the statement so constructed can be prepared for execution by means of the (embedded) statement PREPARE and executed by means of the (embedded) statement EXECUTE, as described in [Dynamically executing an SQL statement by using PREPARE and EXECUTE \(Db2 Application programming and SQL\)](#). Alternatively, you can use the (embedded) statement EXECUTE IMMEDIATE to prepare and execute a statement in one step. In Java, the statement can be prepared for execution by means of the Statement, PreparedStatement, and CallableStatement classes, and executed by means of their respective execute() methods.

The statement can also be prepared by calling the Db2 ODBC SQLPrepare function and then executed by calling the Db2 ODBC SQLExecute function. In both cases, the application does not contain an embedded PREPARE or EXECUTE statement. You can execute the statement, without preparation, by passing the statement to the Db2 ODBC SQLExecDirect function. [Introduction to Db2 ODBC \(Db2 Programming for ODBC\)](#) describes the APIs supported with this interface.

A statement that is going to be prepared must not contain references to host variables. It can instead contain parameter markers. (See [Parameter markers](#) in the description of the PREPARE statement for rules concerning parameter markers.) When the prepared statement is executed, the parameter markers are effectively replaced by current values of the host variables specified in the EXECUTE statement. (See [the EXECUTE statement](#) for rules concerning this replacement.) After it is prepared, a statement can be executed several times with different values of host variables. Parameter markers are not allowed in the SQL statement prepared and executed using EXECUTE IMMEDIATE.

In non-Java languages, the successful or unsuccessful execution of the statement is indicated by the values returned in the SQLCODE and SQLSTATE fields in the SQLCA after the EXECUTE (or EXECUTE IMMEDIATE) statement. You should check the fields as described above for embedded statements. In Java, the successful or unsuccessful execution of the statement is handled by Java Exceptions.

As explained in [“Authorization IDs and dynamic SQL” on page 94](#), the DYNAMICRULES behavior in effect determines the privilege set that is used for authorization checking when dynamic SQL statements are processed. The following table summarizes those privilege sets. (See [“Authorization IDs and dynamic SQL” on page 94](#) for a list of the DYNAMICRULES bind option values that determine which behavior is in effect).

²³ SQLCODE and SQLSTATE cannot be in the SQLCA when the SQL processing option STDSQL(YES) is in effect. See [“SQL standard language” on page 326](#).

Table 171. DYNAMICRULES behaviors and authorization checking

DYNAMICRULES behavior	Privilege set
Run behavior	The union of the set of privileges held by each authorization ID of the process if the dynamically prepared statement is other than an ALTER, CREATE, DROP, GRANT, RENAME, or REVOKE statement. The privileges that are held by the SQL authorization ID of the process or the role of the primary authorization ID (if the process is running in a trusted context that is defined with the ROLE AS OBJECT OWNER clause), if the dynamic SQL statement is a CREATE, GRANT, or REVOKE statement.
Bind behavior	The privileges that are held by the primary authorization ID of the owner of the package or plan.
Define behavior	The privileges that are held by the authorization ID of the stored procedure or user-defined function owner (definer).
Invoke behavior	The privileges that are held by the authorization ID of the stored procedure or user-defined function invoker. However, if the invoker is the primary authorization ID of the process or the CURRENT SQLID value, secondary authorization IDs are also checked if they are needed for the required authorization. Therefore, in that case, the privilege set is the union of the set of privileges that are held by each authorization ID or role (if running in a trusted context).

Static invocation of a SELECT statement

A SELECT statement can be invoked statically in different ways.

You can include a SELECT statement as a part of the (nonexecutable) statement DECLARE CURSOR. Such a statement is executed every time you open the cursor by means of the (embedded) statement OPEN. After the cursor is open, you can retrieve the result table a row at a time by successive executions of the (embedded) SQL FETCH statement.

If the application is using Db2 ODBC, the SELECT statement is first prepared with the SQLPrepare function call. It is then executed with the SQLExecute function call. Data is then fetched with the SQLFetch function call. The application does not explicitly open the cursor.

The SELECT statement used in this way can contain references to host variables. These references are effectively replaced by the values that the variables have at the moment of executing OPEN.

The successful or unsuccessful execution of the SELECT statement is indicated by the values returned in the SQLCODE and SQLSTATE fields in the SQLCA after the OPEN. You should check the fields as described above for embedded statements.

If the application is using Db2 ODBC, the successful execution of the SELECT statement is indicated by the return code from the SQLExecute function call. If necessary, the application can retrieve the SQLCA by calling the SQLGetSQLCA function.

Dynamic invocation of a SELECT statement

Your application program can dynamically build a SELECT statement in the form of a character string placed in a host variable. In general, the statement is built from some data available to the application program (for example, a query obtained from a terminal).

The statement so constructed can be prepared for execution by means of the (embedded) statement PREPARE, and referred to by a (nonexecutable) statement DECLARE CURSOR. The statement is then executed every time you open the cursor by means of the (embedded) statement OPEN. After the cursor is open, you can retrieve the result table a row at a time by successive executions of the (embedded) SQL FETCH statement.

The SELECT statement used in that way must not contain references to host variables. It can instead contain parameter markers. (See "Notes" in ["PREPARE statement"](#) on page 2042 for rules concerning parameter markers.) The parameter markers are effectively replaced by the values of the host variables specified in the OPEN statement. (See ["OPEN statement"](#) on page 2037 for rules concerning this replacement.)

The successful or unsuccessful execution of the SELECT statement is indicated by the values returned in the SQLCODE and SQLSTATE fields in the SQLCA after the OPEN. You should check the fields as described above for embedded statements.

Interactive invocation

An SQL statement submitted to Db2 from a terminal is said to be issued interactively.

IBM relational database management systems allow you to enter SQL statements from a terminal. Db2 for z/OS provides SPUFI to prepare and execute SQL statements. Other products are also available. A statement entered in this way is said to be issued interactively.

A statement issued interactively must not contain parameter markers or references to host variables, because these make sense only in the context of an application program. For the same reason, there is no SQLCA involved.

Related concepts

[Interactive SQL \(Introduction to Db2 for z/OS\)](#)

[The Db2 command line processor \(Db2 Commands\)](#)

Related tasks

[Executing SQL by using SPUFI \(Db2 Application programming and SQL\)](#)

SQL diagnostics information

Db2 uses a diagnostics area to store status information and diagnostics information about the execution of an executable SQL statement.

When an SQL statement other than GET DIAGNOSTICS or *compound-statement* is processed, the current diagnostics area is cleared before processing the SQL statement. As each SQL statement is processed, information about the execution of that SQL statement is recorded in the current diagnostics area as one or more completion conditions or exception conditions.

A completion condition indicates that the SQL statement completed successfully, completed with a warning condition, or completed with a not found condition. An exception condition indicates that the statement was not successful. The GET DIAGNOSTICS statement can be executed in most languages to return conditions and other information about the previously executed SQL statement from the diagnostics area. Additionally, the condition information is provided through language specific mechanisms for SQL procedures, and host language applications.

Related concepts

[Detecting and processing error and warning conditions in host language applications](#)

Errors and warnings conditions in host language applications can be checked by using the SQLCODE or SQLSTATE host variables or by using the SQLCA.

Related reference

[GET DIAGNOSTICS statement](#)

The GET DIAGNOSTICS statement provides diagnostic information about the last SQL statement (other than a GET DIAGNOSTICS statement) that was executed. This diagnostic information is gathered as the previous SQL statement is executed. Some of the information available through the GET DIAGNOSTICS statement is also available in the SQLCA.

[SQL-procedure-statement \(SQL PL\)](#)

An SQL control statement can allow multiple SQL statements to be specified within the SQL control statement. These statements are defined as SQL procedure statements.

Detecting and processing error and warning conditions in host language applications

Errors and warnings conditions in host language applications can be checked by using the `SQLCODE` or `SQLSTATE` host variables or by using the `SQLCA`.

Each host language provides a mechanism for handling diagnostic information.

- In Assembler, C, COBOL, Fortran, and PL/I, an application program that contains executable SQL statements must provide at least one of the following:
 - A structure named `SQLCA`, which can be provided by using the `INCLUDE SQLCA` statement
 - A stand-alone `CHAR(5)` (`CHAR(6)` in C) variable named `SQLSTATE` (`SQLSTT` in Fortran)
 - A stand-alone integer variable named `SQLCODE` (`SQLCOD` in Fortran)
- In Java, for error conditions, the `getSQLState` method of the `JDBC SQLException` class can be used to get the `SQLSTATE` and the `getErrorCode` method can be used to get the `SQLCODE`.
- In REXX, an `SQLCA` is provided automatically.

Whether you define stand-alone `SQLCODE` and `SQLSTATE` host variables or an `SQLCA` in your program depends on the Db2 precompiler option you choose.

If the application is using Db2 ODBC and it calls the `SQLGetSQLCA` function, it need only include an `SQLCA`. Otherwise, all notification of success or errors is specified with return codes for the various function calls.

When you specify `STDSQL(YES)`, which indicates conformance to the SQL standard, you should not define an `SQLCA`. The stand-alone variable for `SQLCODE` must be a valid host variable in the `DECLARE SECTION` of a program. It can also be declared outside of the `DECLARE SECTION` when no variable is defined for `SQLSTATE`. The stand-alone variable for `SQLSTATE` must be declared in the `DECLARE SECTION`. It must not be declared as an element of a structure.

Use a stand-alone `SQLSTATE` to conform with the SQL 2003 Core standard. When you specify `STDSQL(NO)`, which indicates conformance to Db2 rules, you must include an `SQLCA` explicitly to have access to the `SQLSTATE` and `SQLCODE` information.

SQLSTATE

Db2 sets `SQLSTATE` after each SQL statement (other than `GET DIAGNOSTICS` or a compound statement) is executed. Db2 returns values that conform to the error specification in the SQL standard. Thus, application programs can check the execution of SQL statements by testing `SQLSTATE` instead of `SQLCODE`.

`SQLSTATE` provides application programs with common codes for common error conditions (the values of `SQLSTATE` are product-specific if the error or warning is product-specific). Furthermore, `SQLSTATE` is designed so that application programs can test for specific errors or classes of errors. The coding scheme is the same for all IBM implementations of SQL. The `SQLSTATE` values are based on the `SQLSTATE` specifications contained in the SQL standard. Error messages and the tokens that are substituted for variables in error messages are associated with `SQLCODE` values, not `SQLSTATE` values.

In the case of a `LOOP` statement, the `SQLSTATE` is set after the `END LOOP` portion of the `LOOP` statement completes. With the `REPEAT` statement, the `SQLSTATE` is set after the `UNTIL` and `END REPEAT` portions of the `REPEAT` statement completes.

If the application is using Db2 ODBC, the `SQLSTATE` returned conforms to the ODBC Version 2.0 specification.

SQLCODE

The SQLCODE is also set by Db2 after each SQL statement is executed.

SQLCODE

The SQLCODE value is set by Db2 after each statement is executed, as shown in the following table.

SQLCODE value	Meaning	SQLCODE descriptions
SQLCODE = 0	Successful execution, if SQLWARN0 is blank. If SQLWARN0 = 'W', successful execution with warning.	<u>000</u>
SQLCODE = 100	No data was found. For example, a FETCH statement returned no data because the cursor was positioned after the last row of the result table.	<u>+100</u>
SQLCODE > 0 and not = 100	Successful execution with a warning.	<u>+sqlcode-num</u>
SQLCODE < 0	Execution was not successful.	<u>-sqlcode-num</u>

For PDF format descriptions of the SQL codes that Db2 12 might issue, see  [Codes](#).

In the case of a LOOP statement, the SQLSTATE is set after the END LOOP portion of the LOOP statement completes. With the REPEAT statement, the SQLSTATE is set after the UNTIL and END REPEAT portions of the REPEAT statement completes.

The SQL standard does not define the meaning of any other specific positive or negative values of SQLCODE, and the meaning of these values is not the same in all implementations of SQL.

If the application is using Db2 ODBC, an SQLCODE is only returned if the application issues the SQLGetSQLCA function.

Related concepts

[SQL codes \(Db2 Codes\)](#)

Related tasks

[Handling SQL error codes \(Db2 Application programming and SQL\)](#)

SQL comments

Static SQL statements can include host language or SQL comments. Dynamic SQL statements can include SQL comments. There are two types of SQL comments, simple comments and bracketed comments.

simple comments

Simple comments are introduced with two consecutive hyphens (- -) and end with the end of a line. The following rules apply to the use of simple comments:

- The two hyphens must be on the same line and must not be separated by a space.
- Simple comments can be started whenever a space is valid (except within a delimiter token or between 'EXEC' and 'SQL').
- Simple comments cannot be continued to the next line.
- In COBOL, a space must precede the two hyphens (' - -').

bracketed comments

Bracketed comments are introduced with /* and end with */. The following rules apply to the use of bracketed comments:

- The /* must be on the same line and not separated by a space.
- The */ must be on the same line and not separated by a space.
- Bracketed comments can be started wherever a space is valid (except within a delimiter token or between 'EXEC' and 'SQL').
- Bracketed comments can be continued to the next line.
- Bracketed comments can be nested within other bracketed comments. However, nested bracketed comments are not supported by DSNTEP2, DSNTEP4, SPUFI, or the command line processor.
- Bracketed comments are not allowed in static SQL statements in a COBOL, Fortran, or Assembler program.

Example

The following example shows how to include comments in an SQL statement within a C program. The example uses both simple and bracketed comments:

```
EXEC SQL
  CREATE VIEW PRJ_MAXPER          --projects with most support personnel
  /*
   * Returns number and name of the project
   */
  AS SELECT PROJNO, PROJNAME     -- number and name of project
     FROM DSN8910.PROJ
  /*
   * E21 is the systems support dept code
   */
  WHERE DEPTNO = 'E21'          -- systems support dept code
 AND PRSTAFF > 1;
```

Host language comments

For more information about comments in specific host languages, see the following topics:

- [Assembler applications that issue SQL statements \(Db2 Application programming and SQL\)](#)
- [C and C++ applications that issue SQL statements \(Db2 Application programming and SQL\)](#)
- [COBOL applications that issue SQL statements \(Db2 Application programming and SQL\)](#)
- [Fortran applications that issue SQL statements \(Db2 Application programming and SQL\)](#)
- [PL/I applications that issue SQL statements \(Db2 Application programming and SQL\)](#)
- [REXX applications that issue SQL statements \(Db2 Application programming and SQL\)](#)

Related concepts

Characters and tokens in SQL

The most basic elements of SQL syntax are characters and tokens. Tokens are the basic syntactical units of the SQL language.

ALLOCATE CURSOR statement

The ALLOCATE CURSOR statement defines a cursor and associates it with a result set locator variable.

Invocation for ALLOCATE CURSOR

This statement can be embedded in an application program. It is an executable statement that can be dynamically prepared. It cannot be issued interactively.

Authorization for ALLOCATE CURSOR

None required.

Syntax for ALLOCATE CURSOR

```
► ALLOCATE — cursor-name — CURSOR FOR RESULT SET — rs-locator-variable ►
```

Description for ALLOCATE CURSOR

cursor-name

Names the cursor. The name must not identify a cursor that has already been declared in the source program.

CURSOR FOR RESULT SET *rs-locator-variable*

Specifies a result set locator variable that has been declared in the application program according to the rules for declaring result set locator variables.

The result set locator variable must contain a valid result set locator value, as returned by the ASSOCIATE LOCATORS or DESCRIBE PROCEDURE SQL statement. The value of the result set locator variable is used at the time the cursor is allocated. Subsequent changes to the value of the result set locator have no effect on the allocated cursor. The result set locator value must not be the same as a value used for another cursor allocated in the source program.

Notes for ALLOCATE CURSOR

Dynamically prepared ALLOCATE CURSOR statements: The EXECUTE statement with the USING clause must be used to execute a dynamically prepared ALLOCATE CURSOR statement. In a dynamically prepared statement, references to variables are represented by parameter markers (question marks). In the ALLOCATE CURSOR statement, *rs-locator-variable* is always a variable. Thus, for a dynamically prepared ALLOCATE CURSOR statement, the USING clause of the EXECUTE statement must identify the variable whose value is to be substituted for the parameter marker that represents *rs-locator-variable*.

You cannot prepare an ALLOCATE CURSOR statement with a statement identifier that has already been used in a DECLARE CURSOR statement. For example, the following SQL statements are invalid because the PREPARE statement uses STMT1 as an identifier for the ALLOCATE CURSOR statement and STMT1 has already been used for a DECLARE CURSOR statement.

```
DECLARE CURSOR C1 FOR STMT1;  
PREPARE STMT1 FROM          INVALID  
  'ALLOCATE C2 CURSOR FOR RESULT SET ?';
```

Rules for using an allocated cursor: The following rules apply when you use an allocated cursor:

- You cannot open an allocated cursor with the OPEN statement.
- You can close an allocated cursor with the CLOSE statement. Closing an allocated cursor closes the associated cursor defined in the stored procedure.
- You can allocate only one cursor to each result set.

The life of an allocated cursor: A rollback operation, an implicit close, or an explicit close destroy allocated cursors. A commit operation destroys allocated cursors that are not defined WITH HOLD by the stored procedure. Destroying an allocated cursor closes the associated cursor defined in the stored procedure.

Considerations for scrollable cursors: Following an ALLOCATE CURSOR statement, a GET DIAGNOSTICS statement can be used to get the attributes of the cursor such as the following information (for more information, see [“GET DIAGNOSTICS statement”](#) on page 1949):

- DB2_SQL_ATTR_CURSOR_HOLD. Whether the cursor was defined with the WITH HOLD attribute.
- DB2_SQL_ATTR_CURSOR_SCROLLABLE. Scrollability of the cursor.
- DB2_SQL_ATTR_CURSOR_SENSITIVITY. Effective sensitivity of the cursor.

The sensitivity information can be used by applications (such as an ODBC driver) to determine what type of FETCH (INSENSITIVE or SENSITIVE) to issue for a cursor defined as ASENSITIVE.

- DB2_SQL_ATTR_CURSOR_ROWSET. Whether the cursor can be used to access rowsets.
- DB2_SQL_ATTR_CURSOR_TYPE. Whether a cursor type is forward-only, static, or dynamic.
- The scrollability of the cursor is in SQLWARN1.
- The sensitivity of the cursor is in SQLWARN4.
- The effective capability of the cursor is in SQLWARN5.

Example for ALLOCATE CURSOR

The statement in the following example is assumed to be in a PL/I program.

Define and associate cursor C1 with the result set locator variable *LOC1* and the related result set returned by the stored procedure:

```
EXEC SQL ALLOCATE C1 CURSOR FOR RESULT SET :LOC1;
```

ALTER DATABASE statement

The ALTER DATABASE statement changes the description of a database at the current server.

Invocation for ALTER DATABASE

This statement can be embedded in an application program or issued interactively. It is an executable statement that can be dynamically prepared only if DYNAMICRULES RUN behavior is in effect. For more information, see [“Authorization IDs and dynamic SQL”](#) on page 94.

Authorization for ALTER DATABASE

The privilege set that is defined below must include at least one of the following:

- The DROP privilege on the database
- Ownership of the database
- DBADM or DBCTRL authority for the database
- SYSADM or SYSCTRL authority
- System DBADM
- Installation SYSOPR authority (when the current SQLID of the process is set to SYSINSTL)

If the database is implicitly created, the privileges must be on the implicit database or on DSNDB04.

Privilege set: If the statement is embedded in an application program, the privilege set is the privileges that are held by the owner of the package. If the statement is dynamically prepared, the privilege set is the union of the privilege sets that are held by each authorization ID and role of the process.

Syntax for ALTER DATABASE

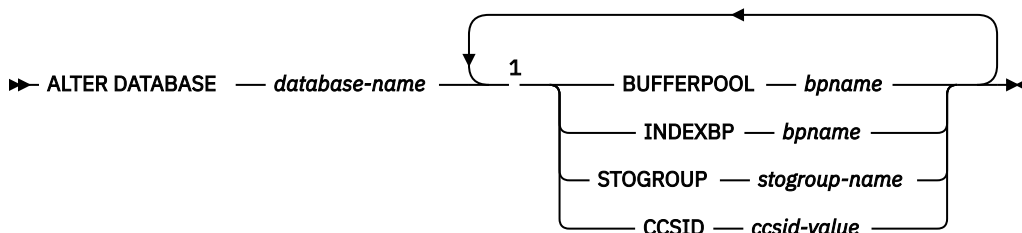

Notes:

- ¹ The same clause must not be specified more than one time.

Description for ALTER DATABASE

DATABASE *database-name*

Identifies the database that is to be altered. The name must identify a database that exists at the current server and must not identify an implicitly created system database.

BUFFERPOOL *bpname*

Identifies the default buffer pool for the table spaces within the database. It does not apply to table spaces that already exist within the database.

If the database is a work file database, 8 KB and 16 KB buffer pools cannot be specified.

If the table space is implicitly created, Db2 selects the buffer pool as described in [Implicitly defined table spaces \(Db2 Administration Guide\)](#).

See [“Naming conventions in SQL” on page 79](#) for more details about *bpname*.

INDEXBP *bpname*

Identifies the default buffer pool for the indexes within the database. It does not apply to indexes that already exist within the database. The name can identify a 4 KB, 8 KB, 16 KB, or 32 KB buffer pool.

See [“Naming conventions in SQL” on page 79](#) for more details about *bpname*.

STOGROUP *stogroup-name*

Identifies the storage group to be used, as required, as a default storage group to support DASD space requirements for table spaces and indexes within the database. It does not apply to table spaces and indexes that already exist within the database.

CCSID *ccsid-value*

Identifies the default CCSID for table spaces within the database. It does not apply to existing table spaces in the database. *ccsid-value* must identify a CCSID value that is compatible with the current value of the CCSID for the database. [“Notes for ALTER DATABASE” on page 1096](#) contains a list that shows the CCSID to which a given CCSID can be altered.

CCSID cannot be specified for a work file database.

Notes for ALTER DATABASE

Altering the CCSID

The ability to alter the default CCSID enables you to change to a CCSID that supports the Euro symbol. You can only convert between specific CCSIDs that do and do not define the Euro symbol. In most cases, the code point that supports the Euro symbol replaces an existing code point, such as the International Currency Symbol (ICS).

Changing a CCSID can be disruptive to the system and requires several steps. For each encoding scheme of a system (ASCII, EBCDIC, and Unicode), Db2 supports SBCS, DBCS, and mixed CCSIDs. Therefore, the CCSIDs for all databases and all table spaces within an encoding scheme should be altered at the same time. Otherwise, unpredictable results might occur.

The recommended method for changing the CCSID requires that the data be unloaded and reloaded. For the steps needed to change the CCSID, such as running an installation CLIST to modify the CCSID data in DSNHDECP, when to drop and re-create views, and when to rebind invalidated packages, see [Working with international data \(Db2 Installation and Migration\)](#).

The following lists show the CCSIDs that can be converted. The second CCSID in each pair is the CCSID with the Euro symbol. The CCSID can be changed from the CCSID that does not support the Euro symbol to the CCSID that does, and vice versa. For example, if the current CCSID is 500, it can be changed to 1148.

EBCDIC CCSIDs	

37	1140
273	1141
277	1142
278	1143
280	1144

284	1145
285	1146
297	1147
500	1148
871	1149

```

ASCII CCSIDs
-----
850      858
874      4970
1250     5346
1251     5347
1252     5348
1253     5349
1254     5350
1255     5351
1256     5352
1257     5353

```

Example for ALTER DATABASE

Change the default buffer pool for both table spaces and indexes within database ABCDE to BP2.

```

ALTER DATABASE ABCDE
  BUFFERPOOL BP2
  INDEXBP BP2;

```

ALTER FUNCTION statement (external function)

The ALTER FUNCTION statement changes the description of a user-defined external scalar function or external table function at the current server.

Invocation for ALTER FUNCTION (external)

This statement can be embedded in an application program or issued interactively. It is an executable statement that can be dynamically prepared only if DYNAMICRULES RUN behavior is in effect. For more information, see [“Authorization IDs and dynamic SQL”](#) on page 94.

Authorization for ALTER FUNCTION (external)

The privilege set defined below must include at least one of the following:

- Ownership of the function
- The ALTERIN privilege on the schema
- SYSADM or SYSCTRL authority
- System DBADM
- Installation SYSOPR authority (when the current SQLID of the process is set to SYSINSTL)

The authorization ID that matches the schema name implicitly has the ALTERIN privilege on the schema.

If the authorization ID that is used to alter the function has the installation SYSADM authority or the installation SYSOPR authority and if the current SQLID is set to SYSINSTL, the function is identified as system-defined function when the function definition is reevaluated.

At least one of the following privileges is required if the SECURED option is specified or if the function is currently secured and the NOT SECURED option is specified:

- SECADM authority
- CREATE_SECURE_OBJECT privilege

For *external scalar functions*, when LANGUAGE is JAVA and a *jar-name* is specified in the EXTERNAL NAME clause, the privilege set must include USAGE on the JAR file.

Privilege set: If the statement is embedded in an application program, the privilege set is the privileges that are held by the owner of the package.

If the statement is dynamically prepared, the privilege set is the set of privileges that are held by the SQL authorization IDs of the process. The specified routine name can include a schema name (a qualifier). However, if the schema name is not the same as one of these SQL authorization IDs, one of the following conditions must be met:

1. The privilege set includes SYSADM authority
2. The privilege set includes SYSCTRL authority
3. The SQL authorization ID of the process has the ALTERIN privilege on the schema

If the environment in which the function is to be run is being changed, the authorization ID must have authority to use the WLM environment specified. The required authorization is obtained from an external security product, such as RACF. For more information, see [Managing authorizations for creation of stored procedures in WLM environments \(Managing Security\)](#).

Syntax for ALTER FUNCTION (external)

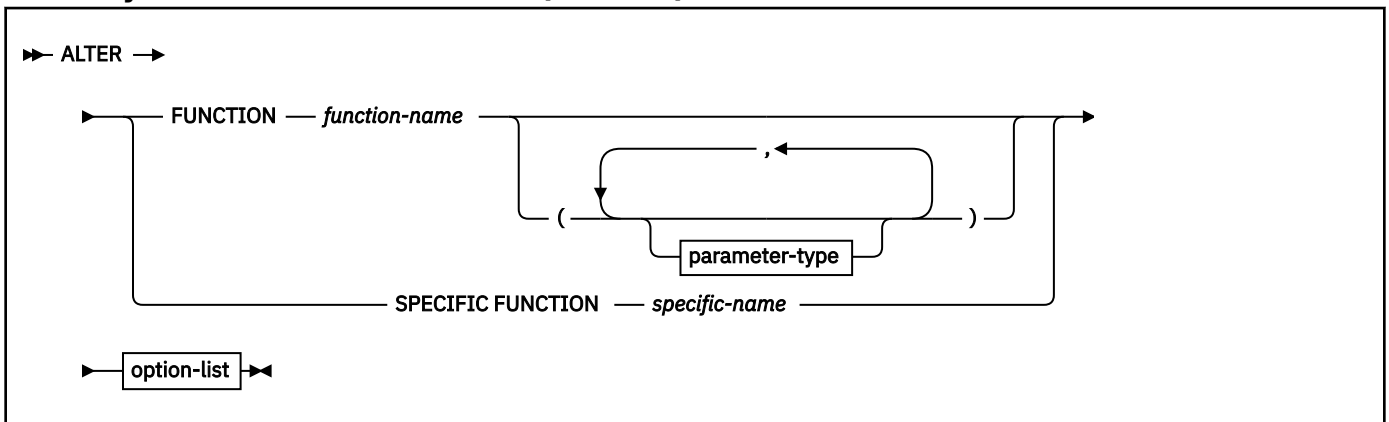

parameter-type:

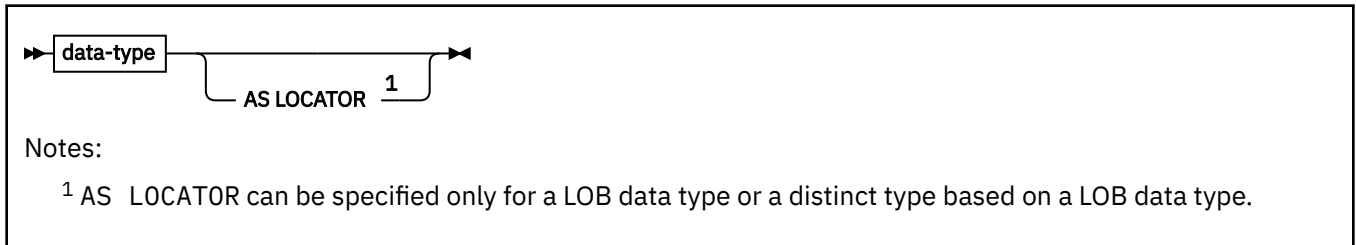

data-type:



built-in-type:

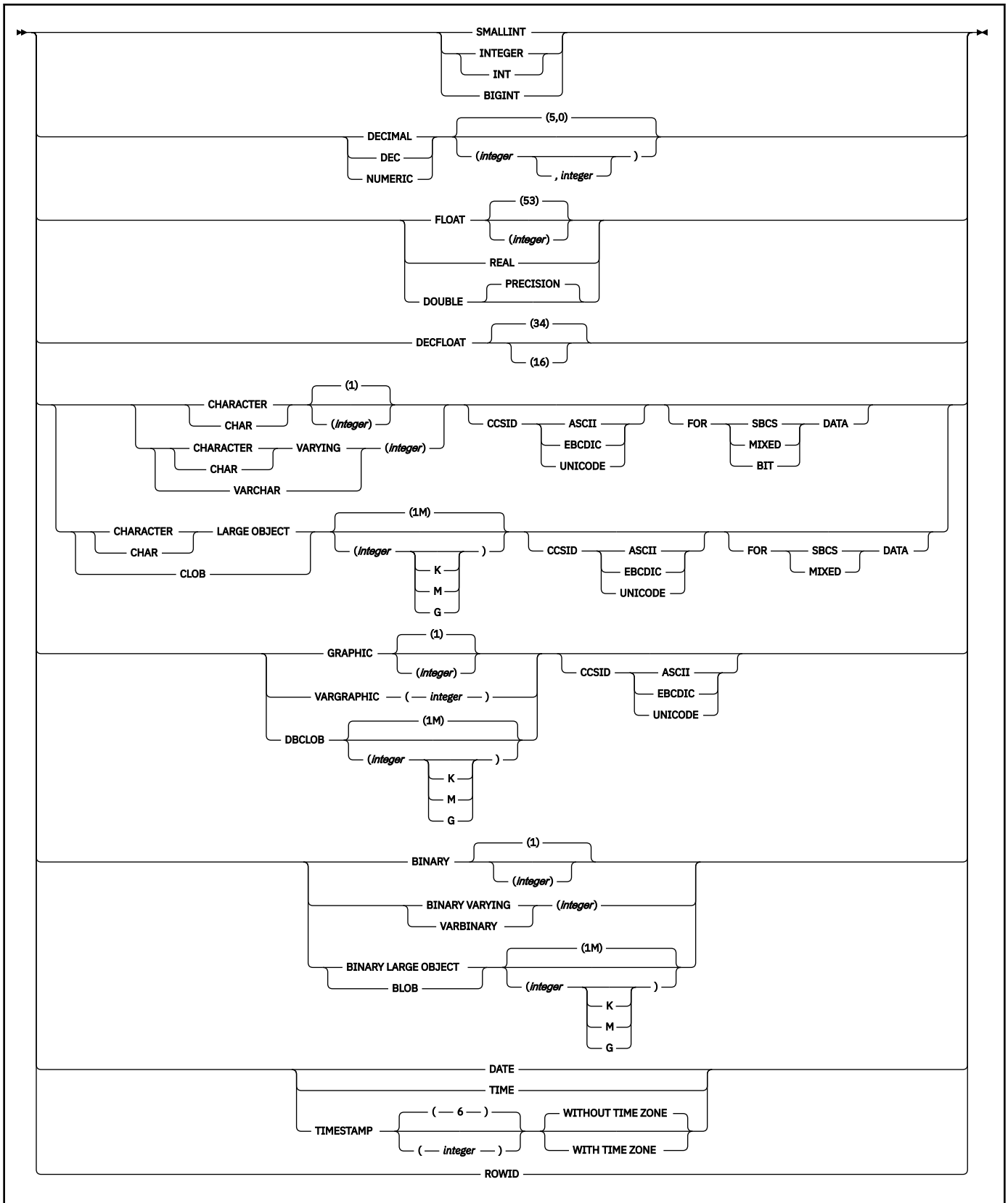

option-list: (Specify options in any order. Specify at least one option. Do not specify the same option more than once.)

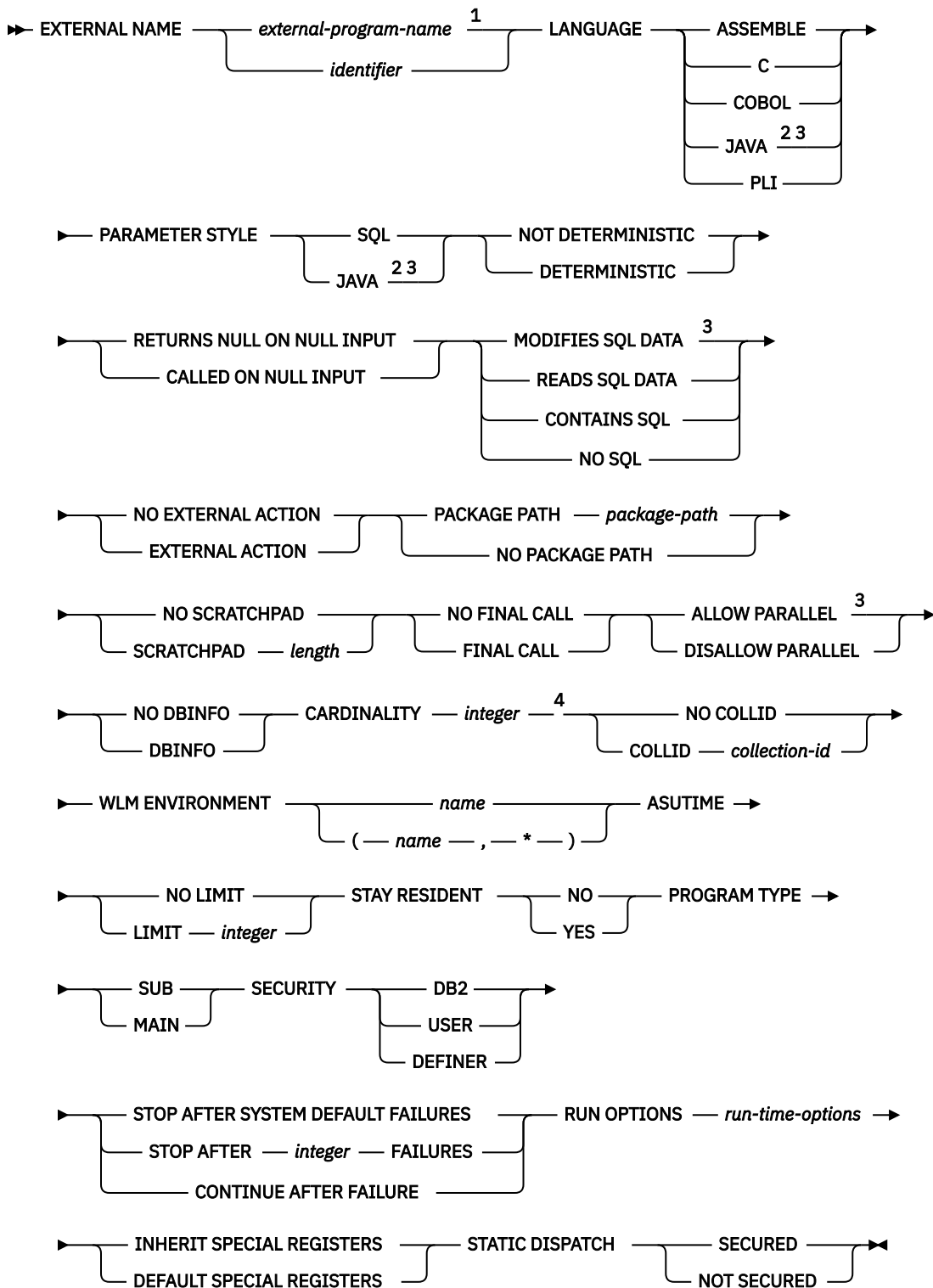

Notes:

- ¹ If LANGUAGE is JAVA, EXTERNAL NAME must be specified with a valid *external-java-routine-name*.
- ² When LANGUAGE JAVA is specified, PARAMETER STYLE JAVA must also be specified. When PARAMETER STYLE JAVA is specified, LANGUAGE JAVA must also be specified.
- ³ LANGUAGE JAVA, PARAMETER STYLE JAVA, MODIFIES SQL DATA, and ALLOW PARALLEL are not supported for *external table functions*.
- ⁴ CARDINALITY is not supported for *external scalar functions*.

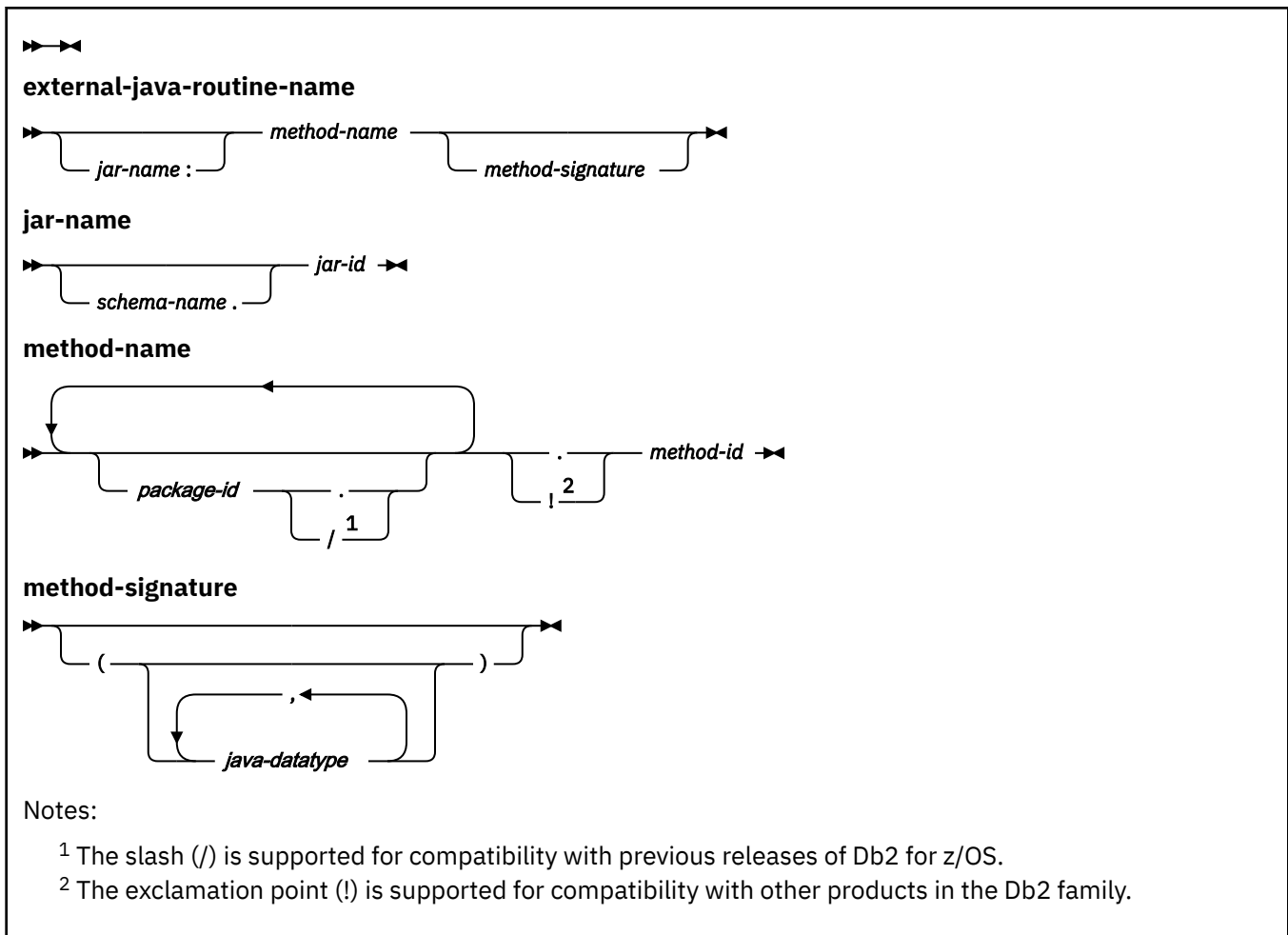

Description for ALTER FUNCTION (external)

One of the following three clauses identifies the function to be changed.

FUNCTION *function-name*

Identifies the external function by its function name. *function-name* must identify a function that exists at the current server. The function must be a user-defined external function, and there must be exactly one function with *function-name* in the schema.

The function can have any number of input parameters. If the schema does not contain a function with *function-name* or contains more than one function with this name, an error occurs.

FUNCTION *function-name* (*parameter-type*,...)

Identifies the external function by its function signature, which uniquely identifies the function.

function-name

Identifies the function by its name.

If *function-name*() is specified, the function that is identified must have zero parameters.

(*parameter-type*,...)

Identifies the number of input parameters of the function and their data types.

The data type of each parameter must match the data type that was specified in the CREATE FUNCTION statement for the parameter in the corresponding position. The number of data types and the logical concatenation of the data types are used to uniquely identify the function. Therefore, you cannot change the number of parameters or the data types of the parameters.

For data types that have a length, precision, or scale attribute, you can use a set of empty parentheses, specify a value, or accept the default values:

If the function was defined with a table parameter (the `LIKE TABLE name AS LOCATOR` clause was specified in the `CREATE FUNCTION` statement to indicate that one of the input parameters is a transition table), the function signature cannot be used to uniquely identify the function. Instead, use one of the other syntax variations to identify the function with its function name, if unique, or its specific name.

- Empty parentheses indicate that Db2 is to ignore the attribute when determining whether the data types match.

For example, `DEC()` will be considered a match for a parameter of a function defined with a data type of `DEC(7,2)`. Similarly `DECFLOAT()` will be considered a match for `DECFLOAT(16)` or `DECFLOAT(34)`.

`FLOAT` cannot be specified with empty parentheses because its parameter value indicates different data types (`REAL` or `DOUBLE`).

- If you use a specific value for a length, precision, or scale attribute, the value must exactly match the value that was specified (implicitly or explicitly) in the `CREATE FUNCTION` statement.

The specific value for `FLOAT(n)` does not have to exactly match the defined value of the source function because $1 < n \leq 21$ indicates `REAL` and $22 < n \leq 53$ indicates `DOUBLE`. Matching is based on whether the data type is `REAL` or `DOUBLE`.

- If length, precision, or scale is not explicitly specified and empty parentheses are not specified, the default length of the data type is implied. The implicit length must exactly match the value that was specified (implicitly or explicitly) in the `CREATE FUNCTION` statement.

For data types with a subtype or encoding scheme attribute, specifying the `FOR subtype DATA` clause or the `CCSID` clause is optional. Omission of either clause indicates that Db2 is to ignore the attribute when determining whether the data types match. If you specify either clause, it must match the value that was implicitly or explicitly specified in the `CREATE FUNCTION` statement.

See [“CREATE FUNCTION statement \(overview\)” on page 1424](#) for more information on the specification of the parameter list.

A function with the function signature must exist in the explicitly or implicitly specified schema.

SPECIFIC FUNCTION *specific-name*

Identifies the external function by its specific name. A function with the specific name must exist in the schema.

The following clauses change the description of the function that has been identified to be changed.

EXTERNAL NAME *external-program-name or identifier*

Identifies the user-written code (program) that runs when the function is invoked.

If `LANGUAGE` is `JAVA`, *external-program-name* must be specified and enclosed in single quotation marks, with no extraneous blanks within the single quotation marks. It must specify a valid *external-java-routine-name*. If multiple *external-program-name* values are specified, the total length of all of them must not be greater than 1305 bytes and they must be separated by a space or a line break. Do not specify a JAR file for a Java function for which `NO SQL` is in effect.

An *external-java-routine-name* contains the following parts:

jar-name

Identifies the name given to the JAR file when it was installed in the database. The name contains *jar-id*, which can optionally be qualified with a schema. Examples are `"myJar"` and `"mySchema.myJar"`. The unqualified *jar-id* is implicitly qualified with a schema name according to the following rules:

- If the statement is embedded in a program, the schema name is the authorization ID in the `QUALIFIER` option of the **BIND** subcommand for a package or plan when the package or plan was created or last changed. The schema name can also be the authorization ID in the `QUALIFIER` option of the `CREATE PROCEDURE` or `ALTER PROCEDURE` statement for a native SQL

procedure when the procedure was created or last changed. If the QUALIFIER is not specified, the schema name is the owner of the package, plan, or native SQL procedure.

- If the statement is dynamically prepared, the schema name is the SQL authorization ID in the CURRENT SCHEMA special register.

If *jar-name* is specified, it must exist when the ALTER FUNCTION statement is processed.

If *jar-name* is not specified, the function is loaded from the class file directly. Db2 searches the directories in the CLASSPATH associated with the WLM Environment. Environmental variables for Java routines are specified in a data set identified in a JAVAENV DD card on the JCL used to start the address space for a WLM-managed function.

method-name

Identifies the name of the method and must not be longer than 254 bytes. Its package, class, and method IDs are specific to Java and as such are not limited to 18 bytes. In addition, the rules for what method IDs can contain are not necessarily the same as the rules for an SQL ordinary identifier.

package-id

Identifies a package. The concatenated list of *package-ids* identifies the package that the class identifier is part of. If the class is part of a package, the method name must include the complete package prefix, such as "myPacks.UserFuncs." The Java virtual machine looks in the directory "/myPacks/UserFuncs/" for the classes.

class-id

Identifies the class identifier of the Java object.

method-id

Identifies the method identifier with the Java class to be invoked.

method-signature

Identifies a list of zero or more Java data types for the parameter list and must not be longer than 1024 bytes. Specify the *method-signature* if the user-defined function involves any input or output parameters that can be NULL. When the function that is being created is called, Db2 searches for a Java method with the exact *method-signature*. The number of *java-datatype* elements that are specified indicates how many parameters that the Java method must have.

A Java procedure can have no parameters. In this case, you code an empty set of parentheses for *method-signature*. If a Java *method-signature* is not specified, Db2 searches for a Java method with a signature derived from the default JDBC types associated with the SQL types specified in the parameter list of the ALTER FUNCTION statement.

For other values of LANGUAGE, the value must conform to the naming conventions for load modules: the value must be less than or equal to 8 bytes, and it must conform to the rules for an ordinary identifier with the exception that it must not contain an underscore.

LANGUAGE

Specifies the application programming language in which the function is written. All programs must be designed to run in IBM's Language Environment® environment.

ASSEMBLE

The function is written in Assembler.

C

The function is written in C or C++.

COBOL

The function is written in COBOL, including the object-oriented language extensions.

JAVA

The user-defined function is written in Java and is executed in the Java virtual machine. If the ALTER FUNCTION statement results in changing LANGUAGE to JAVA, PARAMETER STYLE JAVA and an EXTERNAL NAME clause must be specified to provide the appropriate values. When LANGUAGE JAVA is specified, the EXTERNAL NAME clause must also be specified with a valid *external-java-routine-name* and PARAMETER STYLE must be specified with JAVA.

Do not specify LANGUAGE JAVA when SCRATCHPAD, FINAL CALL, DBINFO, PROGRAM TYPE MAIN, or RUN OPTIONS is specified. Do not specify LANGUAGE JAVA for a table function.

PLI

The function is written in PL/I.

PARAMETER STYLE

Specifies the linkage convention that the function program uses to receive input parameters from and pass return values to the invoking SQL statement.

SQL

Specifies the parameter passing convention that supports passing null values both as input and for output. The parameters that are passed between the invoking SQL statement and the function include:

- Input parameters. The first n parameters are the input parameters that are specified for the function.
- Result parameters. For an external scalar function, a parameter for the result of the function. For an external table function, the next m parameters that are specified on the RETURNS TABLE clause of the CREATE statement that defined the function.
- Input parameter indicator variables. n parameters for the indicator variables for the input parameters.
- Result parameter indicator variables. For an external scalar function, a parameter for the indicator variable for the result of the function that is specified on the RETURNS clause of the CREATE statement that defined the function. For an external table function, m parameters for the indicator variables of the result columns of the function that are specified on the RETURNS TABLE clause of the CREATE statement that defined the function.
- The SQLSTATE to be returned to Db2.
- The qualified name of the function.
- The specific name of the function.
- The SQL diagnostic string to be returned to Db2.
- The scratchpad, if SCRATCHPAD is specified.
- The call type. For an external scalar function, the call type is passed only if FINAL CALL is specified. The call type is always passed for an external table function.
- The DBINFO structure, if DBINFO is specified.

JAVA

Indicates that the user-defined function uses a convention for passing parameters that conforms to the Java and SQLJ specifications. If the ALTER FUNCTION statement results in changing LANGUAGE to JAVA, PARAMETER STYLE JAVA and an EXTERNAL NAME clause must be specified to provide the appropriate values. PARAMETER STYLE JAVA can be specified only if LANGUAGE is JAVA. JAVA must be specified for PARAMETER STYLE when LANGUAGE is JAVA.

Do not specify PARAMETER STYLE JAVA for a table function.

NOT DETERMINISTIC or DETERMINISTIC

Specifies whether the function returns the same results each time that the function is invoked with the same input arguments.

NOT DETERMINISTIC

The function might not return the same result each time that the function is invoked with the same input arguments. The function depends on some state values that affect the results. Db2 uses this information to disable the merging of views and table expressions when processing SELECT or SQL data change statements that refer to this function. An example of a function that is not deterministic is one that generates random numbers, or any function that contains SQL statements.

Some SQL functions that invoke functions that are not deterministic can receive incorrect results if the function is executed by parallel tasks. Specify the `DISALLOW PARALLEL` clause for these functions.

If a view or a materialized query table definition refers to the function, the function cannot be changed to `NOT DETERMINISTIC`. To change the function, drop any views or materialized query tables that refer to the function first.

DETERMINISTIC

The function always returns the same result each time that the function is invoked with the same input arguments. An example of a deterministic function is a function that calculates the square root of the input. Db2 uses this information to enable the merging of views and table expressions for `SELECT` or `SQL` data change statements that refer to this function. If applicable, specify `DETERMINISTIC` to prevent non-optimal access paths from being chosen for `SQL` statements that refer to this function.

Db2 does not verify that the function program is consistent with the specification of `DETERMINISTIC` or `NOT DETERMINISTIC`.

RETURNS NULL ON NULL INPUT or CALLED ON NULL INPUT

Specifies whether the function is called if any of the input arguments is null at execution time.

RETURNS NULL ON NULL INPUT

The function is not called if any of the input arguments is null. For an external scalar function, the result is the null value. For an external table function, the result is an empty table, which is a table with no rows.

CALLED ON NULL INPUT

The function is called regardless of whether any of the input arguments are null, making the function responsible for testing for null argument values. For an external scalar function, the function can return a null or nonnull value. For an external table function, the function can return an empty table, depending on its logic.

MODIFIES SQL DATA, READS SQL DATA, CONTAINS SQL, or NO SQL

Specifies the classification of `SQL` statements and nested routines that this routine can execute or invoke. The database manager verifies that the `SQL` statements issued by the function, and all routines locally invoked by the routine, are consistent with this specification; the verification is not performed when nested remote routines are invoked. For the classification of each statement, see [Appendix D, “SQL statement data access classification for routines,”](#) on page 2275.

MODIFIES SQL DATA

Specifies that the function can execute any `SQL` statement except the statements that are not supported in functions. Do not specify `MODIFIES SQL DATA` when `ALLOW PARALLEL` is in effect.

If a function that is defined with `MODIFIES SQL DATA` is invoked anywhere except the *select-clause* of the outermost `SELECT` statement, the results are unpredictable because the function can be invoked multiple times depending on the access plan that is used.

Recommendation: If a `SELECT` statement invokes a function that is defined with the `MODIFIES SQL DATA` option, ensure that statements nested inside the function do not modify objects that are referenced in any `SQL` statement at a higher level of nesting. Otherwise, unpredictable results are likely to occur.

READS SQL DATA

Specifies that the function can execute statements with a data access indication of `READS SQL DATA`, `CONTAINS SQL`, or `NO SQL`. The function cannot execute `SQL` statements that modify data.

CONTAINS SQL

Specifies that the function can execute only `SQL` statements with a data classification of `CONTAINS SQL` or `NO SQL`. `SQL` statements that neither read nor modify `SQL` data can be executed by the function. Statements that are not supported in any function return a different error.

NO SQL

Specifies that the function can execute only SQL statements with a data access classification of NO SQL. Do not specify NO SQL for a Java function that uses a JAR file.

NO EXTERNAL ACTION or EXTERNAL ACTION

Specifies whether the function takes an action that changes the state of an object that Db2 does not manage. An example of an external action is sending a message or writing a record to a file.

Because Db2 uses the RRS attachment for external functions, Db2 can participate in two-phase commit with any other resource manager that uses RRS. For resource managers that do not use RRS, there is no coordination of commit or rollback operations on non-Db2 resources.

NO EXTERNAL ACTION

The function does not take any action that changes the state of an object that Db2 does not manage. Db2 uses this information to enable the merging of views and table expressions for SELECT or SQL data change statements that refer to this function. If applicable, specify NO EXTERNAL ACTION to prevent non-optimal access paths from being chosen for SQL statements that refer to this function.

EXTERNAL ACTION

The function can take an action that changes the state of an object that Db2 does not manage.

Some SQL statements that invoke functions with external actions can result in incorrect results if parallel tasks execute the function. For example, if the function sends a note for each initial call to it, one note is sent for each parallel task instead of once for the function. Specify the DISALLOW PARALLEL clause for functions that do not work correctly with parallelism.

If you specify EXTERNAL ACTION, Db2:

- Materializes the views and table expressions in SELECT or SQL data change statements that refer to the function. This materialization can adversely affect the access paths that are chosen for the SQL statements that refer to this function. Do not specify EXTERNAL ACTION if the function does not have an external action.
- Does not move the function from one task control block (TCB) to another between FETCH operations.
- Does not allow another function or stored procedure to use the TCB until the cursor is closed. This is also applicable for cursors declared WITH HOLD.

The only changes to resources made outside of Db2 that are under the control of commit and rollback operations are those changes made under RRS control.

If a view or a materialized query table definition refers to the function, the function cannot be changed to EXTERNAL ACTION. To change the function, drop any views or materialized query tables that refer to the function first.

Db2 does not verify that the function program is consistent with the specification of EXTERNAL ACTION or NO EXTERNAL ACTION.

NO PACKAGE PATH or PACKAGE PATH *package-path*

Identifies the package path to use when the function is run. This is the list of the possible package collections into which the DBRM that is associated with the function is bound.

NO PACKAGE PATH

Specifies that the list of package collections for the function is the same as the list of package collections for the program that invokes the function. If the program that invokes the function does not use a package, Db2 resolves the package by using the CURRENT PACKAGE PATH special register, the CURRENT PACKAGESET special register, or the PKLIST bind option (in this order). For information about how Db2 uses these three items, see [Binding an application plan \(Db2 Application programming and SQL\)](#).

PACKAGE PATH *package-path*

Specifies a list of package collections, in the same format as used in the SET CURRENT PACKAGE PATH statement.

If the COLLID clause is specified with PACKAGE PATH, the COLLID clause is ignored when the function is invoked.

The *package-path* value that is associated with the function definition is checked when the function is invoked. If *package-path* contains SESSION_USER (or USER), PATH, or PACKAGE PATH, an error is returned when the *package-path* value is checked.

NO SCRATCHPAD or SCRATCHPAD

Specifies whether Db2 is to provide a scratchpad for the function. Using reentrant external functions and a scratchpad (which provides an area for the function to save information from one invocation to the next) is strongly recommended.

NO SCRATCHPAD

A scratchpad is not allocated and passed to the function.

SCRATCHPAD length

When the function is invoked for the first time, Db2 allocates memory for a scratchpad. A scratchpad has the following characteristics:

- *length* must be in the range 1–32767. The default value is 100 bytes.
- Db2 initializes the scratchpad to all binary zeros (X'00').
- The scope of a scratchpad is the SQL statement. For each reference to the function in an SQL statement, there is one scratchpad.

For example, assuming that user-defined function UDFX is a scalar function that is defined with the SCRATCHPAD option, three scratchpads are allocated for the three references to UDFX in the following SQL statement:

```
SELECT A, UDFX(A) FROM TABLEB
WHERE UDFX(A) > 103 OR UDFX(A) < 19;
```

For another example, assume that UDFX is a user-defined table function that is defined with the SCRATCHPAD option. Two scratchpads are allocated for the two references to function UDFX in the following SQL statement:

```
SELECT *
FROM TABLE (UDFX(A)), TABLE (UDFX(B));
```

If the function is run under parallel tasks, one scratchpad is allocated for each parallel task of each reference to the function in the SQL statement. This can lead to unpredictable results. For example, if a function uses the scratchpad to count the number of times that it is invoked, the count reflects the number of invocations done by the parallel task and not the SQL statement. Specify the DISALLOW PARALLEL clause for functions that do not work correctly with parallelism.

- The scratchpad is persistent. Db2 preserves its content from one invocation of the function to the next. Any changes that the function makes to the scratchpad on one call are still there on the next call. Db2 initializes the scratchpads when it begins to execute an SQL statement. Db2 does not reset scratchpads when a correlated subquery begins to execute.
- The scratchpad can be a central point for the system resources that the function acquires. If the function acquires system resources, specify FINAL CALL to ensure that Db2 calls the function one more time so that the function can free those system resources.

Each time that the function is invoked, Db2 passes an additional argument to the function that contains the address of the scratchpad.

If you specify SCRATCHPAD, Db2:

- Does not move the function from one TCB or address space to another between FETCH operations.
- Does not allow another function or stored procedure to use the TCB until the cursor is closed. This is also applicable for cursors declared WITH HOLD.

Do not specify SCRATCHPAD when LANGUAGE JAVA is specified.

NO FINAL CALL or FINAL CALL

Specifies whether a final call is made to the function. A *final call* enables the function to free any system resources that it has acquired. A final call is useful when the function has been defined with the SCRATCHPAD keyword and the function acquires system resource and anchors them in the scratchpad.

The effect of NO FINAL CALL or FINAL CALL depends on whether the external function is a scalar function or a table function.

For an external scalar function:**NO FINAL CALL**

A final call is not made to the external scalar function. The function does not receive an additional argument that specifies the type of call.

FINAL CALL

A final call is made to the external scalar function. See the following description of call types for the characteristics of a final call. When FINAL CALL is specified, the function receives an additional argument that specifies the type of call to enable the function to differentiate between a final call and another type of call. Do not specify FINAL CALL when LANGUAGE JAVA is specified.

For more information on NO FINAL CALL and FINAL CALL for external scalar functions, including the types of calls, see the description of the option for [“CREATE FUNCTION statement \(external scalar function\)”](#) on page 1453.

For an external table function:**NO FINAL CALL**

A first and final call are not made to the external table function.

FINAL CALL

A first call and final call are made to the external table function in addition to one or more other types of calls.

For both NO FINAL CALL and FINAL CALL, the function receives an additional argument that specifies the type of call. For more information on NO FINAL CALL and FINAL CALL for external table functions, including the types of calls, see the description of the option for [“CREATE FUNCTION statement \(external table function\)”](#) on page 1472.

ALLOW or DISALLOW PARALLEL

Specifies whether, for a single reference to the function, the function can be executed in parallel. If the function is defined with MODIFIES SQL DATA, specify DISALLOW PARALLEL, not ALLOW PARALLEL.

ALLOW PARALLEL

Specifies that Db2 can consider parallelism for the function. Parallelism is not forced on the SQL statement that invokes the function or on any SQL statement in the function. Existing restrictions on parallelism apply.

See SCRATCHPAD, EXTERNAL ACTION, and FINAL CALL for considerations when specifying ALLOW PARALLEL.

DISALLOW PARALLEL

Specifies that Db2 does not consider parallelism for the function.

NO DBINFO or DBINFO

Specifies whether additional status information is passed to the function when it is invoked.

NO DBINFO

Additional information is not passed.

DBINFO

An additional argument is passed when the function is invoked. The argument is a structure that contains information such as the application run time authorization ID, the schema name, the name of a table or column that the function might be inserting into or updating, and identification

of the database server that invoked the function. For details about the argument and its structure, see [DBINFO structure \(Db2 Application programming and SQL\)](#).

Do not specify DBINFO when LANGUAGE JAVA is specified.

CARDINALITY *integer*

Specifies an estimate of the expected number of rows that the function returns. The number is used for optimization purposes. The value of *integer* must range 0–2147483647.

If a function has an infinite cardinality (which means that the function never returns the "end-of-table" condition and always returns a row), a query that requires the end-of-table condition to work correctly needs to be interrupted. Thus, avoid using such functions in queries that involve GROUP BY and ORDER BY.

Do not specify CARDINALITY for external scalar functions.

NO COLLID or COLLID *collection-id*

Identifies the package collection that is to be used when the function is executed. This is the package collection into which the DBRM that is associated with the function is bound.

NO COLLID

Specifies the package collection for the function is the same as the package collection of the program that invokes the function. If a trigger invokes the function, the collection of the trigger package is used. If the invoking program does not use a package, Db2 resolves the package by using the CURRENT PACKAGE PATH special register, the CURRENT PACKAGESET special register, or the PKLIST bind option (in this order). For details about how Db2 uses these three items, see the information on package resolution in [Binding an application plan \(Db2 Application programming and SQL\)](#).

COLLID *collection-id*

Specifies the name of the package collection that is to be used when the function is executed.

WLM ENVIRONMENT

An SQL identifier that identifies the *name* of the WLM (workload manager) application environment in which the function is to run.

name

The WLM environment in which the function must run. If the user-defined function is nested and if the calling stored procedure or invoking user-defined function is not running in an address space associated with the specified WLM environment, Db2 routes the function request to a different address space.

(name,*)

When an SQL application program calls the function, *name* specifies the WLM environment in which the function runs.

If another user-defined function or a stored procedure calls the function, the function runs in the same environment that the calling routine uses. In this case, authorization to run the function in the WLM environment is not checked because the authorization of the calling routine suffices.

The *name* of the WLM environment is an SQL identifier.

You must have appropriate authority for the WLM environment.

ASUTIME

Specifies the total amount of processor time, in CPU service units, that a single invocation of the function can run. The value is unrelated to the ASUTIME column of the resource limit specification table.

When you are debugging a function, setting a limit can be helpful if the function gets caught in a loop. For information on service units, see [z/OS MVS Initialization and Tuning Guide](#).

NO LIMIT

There is no limit on the service units.

LIMIT *integer*

The limit on the number of CPU service units is a positive *integer* in the range 1–2147483647. If the procedure uses more service units than the specified value, Db2 cancels the procedure. The CPU cycles that are consumed by parallel tasks in a procedure do not contribute towards the specified ASUTIME LIMIT.

STAY RESIDENT

Specifies whether the load module for the function is to remain resident in memory when the function ends.

NO

The load module is deleted from memory after the function ends. Use NO for non-reentrant functions.

YES

The load module remains resident in memory after the function ends. Use YES for reentrant functions.

PROGRAM TYPE

Specifies whether the function program runs as a main routine or a subroutine.

SUB

The function runs as a subroutine.

MAIN

The function runs as a main routine.

Do not specify PROGRAM TYPE MAIN when LANGUAGE JAVA is in effect.

SECURITY

Specifies how the function interacts with an external security product, such as RACF, to control access to non-SQL resources.

DB2

The function does not require an external security environment. If the function accesses resources that an external security product protects, the access is performed using the authorization ID associated with the WLM-established stored procedure address space.

USER

An external security environment should be used with the function. If the function accesses resources that the external security product protects, the access is performed using the primary authorization ID of the process that invoked the function.

DEFINER

An external security environment should be used with the function. If the function accesses resources that the external security product protects, the access is performed using the authorization ID of the owner of the function.

STOP AFTER SYSTEM DEFAULT FAILURES, STOP AFTER *nn* FAILURES, or CONTINUE AFTER FAILURE

Specifies whether the routine is to be put in a stopped state after some number of failures. The following options must not be specified for SQL functions or sourced functions.

STOP AFTER SYSTEM DEFAULT FAILURES

Specifies that this routine should be placed in a stopped state after the number of failures indicated by the value of field MAX ABEND COUNT on installation panel DSNTIPX.

STOP AFTER *nn* FAILURES

Specifies that this routine should be placed in a stopped state after *nn* failures. The value *nn* can be an integer 1–32767.

CONTINUE AFTER FAILURE

Specifies that this routine should not be placed in a stopped state after any failure.

RUN OPTIONS *run-time-options*

Specifies the Language Environment run time options to be used for the function. You must specify *run-time-options* as a character string that is no longer than 254 bytes. To replace any existing run

time options with no options, specify an empty string with RUN OPTIONS. When you specify an empty string, Db2 does not pass any run time options to Language Environment, and Language Environment uses its installation defaults.

For a description of the Language Environment run time options, see [Language Environment Programming Reference \(z/OS Language Environment Programming Reference\)](#).

Do not specify RUN OPTIONS when LANGUAGE JAVA is specified.

INHERIT SPECIAL REGISTERS or DEFAULT SPECIAL REGISTERS

Specifies how special registers are set on entry to the routine.

INHERIT SPECIAL REGISTERS

Specifies that special registers should be inherited according to the rules listed in the table for characteristics of special registers in a user-defined function in [“Special registers in a user-defined function or a stored procedure”](#) on page 215.

DEFAULT SPECIAL REGISTERS

Specifies that special registers should be initialized to the default values, as indicated by the rules in the table for characteristics of special registers in a user-defined function in [“Special registers in a user-defined function or a stored procedure”](#) on page 215.

STATIC DISPATCH

At function resolution time, Db2 chooses a function based on the static (or declared) types of the function parameters.

SECURED or NOT SECURED

Specifies whether the function is considered secure.

SECURED

Specifies that the function is considered secure.

Use of this clause or keyword might invalidate packages that depend on the target object, or packages that depend on related objects through cascading effects. See [Changes that invalidate packages \(Db2 Application programming and SQL\)](#).

NOT SECURED

Specifies that the function is considered not secure. NOT SECURED must not be specified when a row permission or a column mask depends on the function.

When the function is invoked, the arguments of the function must not reference a column for which a column mask is enabled when the table is using active column access control.

Use of this clause or keyword might invalidate packages that depend on the target object, or packages that depend on related objects through cascading effects. See [Changes that invalidate packages \(Db2 Application programming and SQL\)](#).

Notes for ALTER FUNCTION (external)

Invalidation of packages:

This statement might invalidate all packages that depend on target objects, and sometimes other related objects through cascading effects, depending on the clauses and keywords specified and other factors. For more information, see [Changes that invalidate packages \(Db2 Application programming and SQL\)](#).

LANGUAGE C and the PARAMETER VARCHAR clause:

The ALTER statement does not allow you to alter the value of the PARAMETER VARCHAR or PARAMETER CCSID clauses that are associated with the function definition. However, you can alter the LANGUAGE clause for the function. If the PARAMETER VARCHAR clause is specified for the creation of a LANGUAGE C function, the catalog information for that option is not affected by a subsequent ALTER function statement. The function might be changed to a language other than C, in which case the PARAMETER VARCHAR setting is ignored. If the function is later changed back to LANGUAGE C, the setting of the PARAMETER VARCHAR option that was specified during the CREATE FUNCTION statement will be used.

Altering a function from NOT SECURED to SECURED:

Typically, the security administrator will examine the data that is accessed by a function, ensure that it is secure, and grant the CREATE_SECURE_OBJECT privilege to the user that requires privileges to change the user-defined function to be secured. After the function is changed to SECURED, the security administrator will revoke the CREATE_SECURE_OBJECT privilege from the owner of the function.

The function is considered secure after the ALTER FUNCTION statement is executed. Db2 treats the SECURED attribute as an assertion that declares that the security administrator has established an audit procedure for all changes to the user-defined function. Db2 assumes that such a control audit procedure is in place for all subsequent ALTER FUNCTION statements or changes to external packages.

Packages and statements in the dynamic statement cache that reference the function are invalidated.

Altering a function from SECURED to NOT SECURED:

Packages and statements in the dynamic statement cache that reference the function are invalidated when the function is changed from SECURED to NOT SECURED. An function that is not secured might negatively impact performance if that function accesses data in a table that is using row access control or column access control. To minimize the performance impact, either change the function to use the SECURED option or deactivate row access control or column access control for the table that the function is accessing.

Invoking other user-defined functions in a secure function:

When a secure user-defined function is referenced in an SQL data change statement that references a table that is using row access control or column access control, and if the secure user-defined function invokes other user-defined functions, the nested user-defined functions are not validated as secure. If those nested functions can access sensitive data, the security administrator needs to ensure that those functions are allowed to access sensitive data and should ensure that a change control audit procedure has been established for all changes to those functions.

The SECURE column in the DSN_FUNCTION_TABLE EXPLAIN table:

The SECURE column in the DSN_FUNCTION_TABLE EXPLAIN table indicates if a user-defined function is considered secure.

Alternative syntax and synonyms:

To provide compatibility with previous releases of Db2 or other products in the Db2 family, Db2 supports the following keywords:

- VARIANT as a synonym for NOT DETERMINISTIC
- NOT VARIANT as a synonym for DETERMINISTIC
- NOT NULL CALL as a synonym for RETURNS NULL ON NULL INPUT
- NULL CALL as a synonym for CALLED ON NULL INPUT
- PARAMETER STYLE DB2SQL as a synonym for PARAMETER STYLE SQL
- TIMEZONE can be specified as an alternative to TIME ZONE.

Examples for ALTER FUNCTION (external)**Example 1**

Assume that two functions CENTER are in the PELLOW schema. The first function has two input parameters with INTEGER and FLOAT data types, respectively. The specific name for the first function is FOCUS1. The second function has three parameters with CHAR(25), DEC(5,2), and INTEGER data types.

Using the specific name to identify the function, change the WLM environment in which the first function runs from WLMENVNAME1 to WLMENVNAME2:

```
ALTER SPECIFIC FUNCTION ENGLS.FOCUS1 WLM ENVIRONMENT WLMENVNAME2;
```

Example 2

Change the second function that is described in *Example 1* so that it is not invoked when any of the arguments are null. Use the function signature to identify the function:

```
ALTER FUNCTION ENGLS.CENTER (CHAR(25), DEC(5,2), INTEGER)
  RETURNS NULL ON NULL INPUT;
```

You can also code the ALTER FUNCTION statement without the exact values for the CHAR and DEC data types:

```
ALTER FUNCTION ENGLS.CENTER (CHAR(), DEC(), INTEGER)
  RETURNS NULL ON NULL INPUT;
```

If you use empty parentheses, Db2 ignores the length, precision, and scale attributes when looking for matching data types to find the function.

Related concepts

[External functions \(Db2 Application programming and SQL\)](#)

Related tasks

[Altering user-defined functions \(Db2 Administration Guide\)](#)

ALTER FUNCTION statement (compiled SQL scalar function)

The ALTER FUNCTION (compiled SQL scalar) statement changes the description of a user-defined compiled SQL scalar function at the current server. The function options, parameter names, and routine body can be changed and additional versions of the procedure can be defined and maintained using the ALTER FUNCTION statement.

Invocation for ALTER FUNCTION (compiled SQL scalar)

This statement can only be dynamically prepared and the DYNAMICRULES run behavior must be specified implicitly or explicitly.

Authorization for ALTER FUNCTION (compiled SQL scalar)

The privilege set defined below must include at least one of the following:

- Ownership of the function
- The ALTERIN privilege on the schema
- System DBADM authority
- SYSCTRL authority
- SYSADM
- Installation SYSOPR authority (when the current SQLID of the process is set to SYSINSTL)

The authorization ID that matches the schema name implicitly has the ALTERIN privilege on the schema.

If the authorization ID that is used to alter the function has the installation SYSADM authority or the installation SYSOPR authority and if the current SQLID is set to SYSINSTL, the function is identified as system-defined function when the function definition is reevaluated.

Additional privileges might be required in the following situations:

- If *SQL-routine-body* is specified, the privilege set must include the privileges that are required to execute the statements in *SQL-routine-body*.
- If a user-defined type is referenced (i.e. as the data type of an SQL variable in the body of the function), the privilege set must include at least one of the following:
 - Ownership of the distinct type
 - The USAGE privilege on the user-defined type

- System DBADM authority
- DATAACCESS authority
- SYSADM authority
- If the function uses a table as a parameter, the privilege set must also include at least one of the following:
 - Ownership of the table
 - The SELECT privilege on the table
 - DATAACCESS authority
 - SYSADM authority
- If you specify the WLM ENVIRONMENT FOR DEBUG MODE clause, RACF or an external security product is invoked to check the required authority for defining programs in the WLM environment. If the WLM environment access is protected in RACF, the privilege set must include the required authority.
- When replacing an SQL scalar function, the privilege set must include the required authorization to add a new package or a new version of an existing package depending on the value of the BIND NEW PACKAGE field on installation panel DSNTIPP, or the privilege set must include SYSADM or SYSCTRL authority.

Additional authorization might be required on the SYSDUMMYx tables depending on the content of the function definition. For details, see [SYSDUMMYx tables \(Introduction to Db2 for z/OS\)](#).

At least one of the following privileges is required if the SECURED option is specified or if the function is currently secured and the NOT SECURED option is specified:

- SECADM authority
- CREATE_SECURE_OBJECT privilege

At least one of those privileges is also required if the function is currently secure and the ALTER ACTIVE VERSION, ALTER VERSION *routine-version-id*, ADD VERSION, or REPLACE clause is specified.

Privilege set: If the statement is embedded in an application program, the privilege set is the privileges that are held by the owner of the package.

If the statement is dynamically prepared, the privilege set is the set of privileges that are held by the SQL authorization IDs of the process. The specified routine name can include a schema name (a qualifier). However, if the schema name is not the same as one of these SQL authorization IDs, one of the following conditions must be met:

1. The privilege set includes SYSADM authority
2. The privilege set includes SYSCTRL authority
3. The SQL authorization ID of the process has the ALTERIN privilege on the schema

When ALTER FUNCTION is issued in a trusted context that has the ROLE AS OBJECT OWNER clause, the package owner is determined as follows:

- If the PACKAGE OWNER option is not specified, the role associated with the binder becomes the package owner.
- If the PACKAGE OWNER option is specified, the role specified in the PACKAGE OWNER option becomes the package owner. In a trusted context, the PACKAGE OWNER specified must be a role.

Syntax for ALTER FUNCTION (compiled SQL scalar)

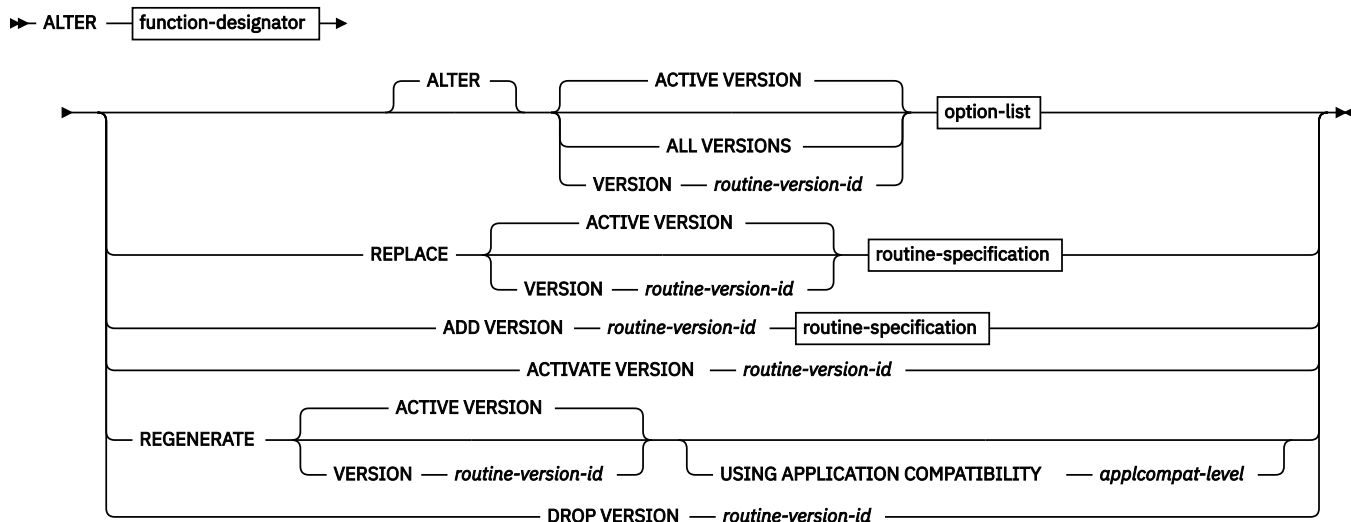

function-designator:

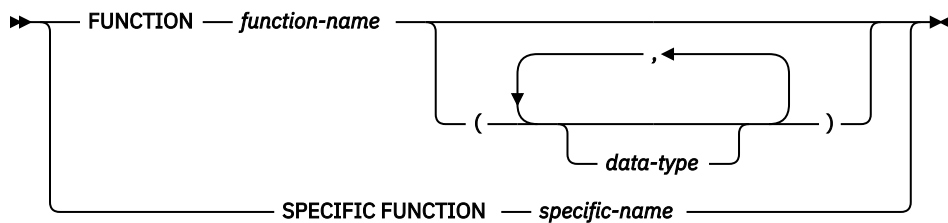

routine-specification:

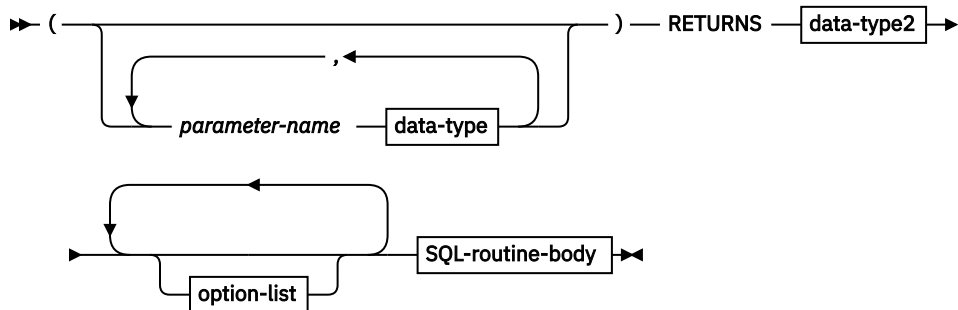

data-type, data-type2:

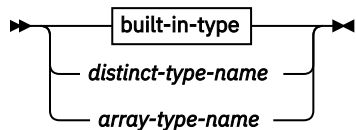

built-in-type:

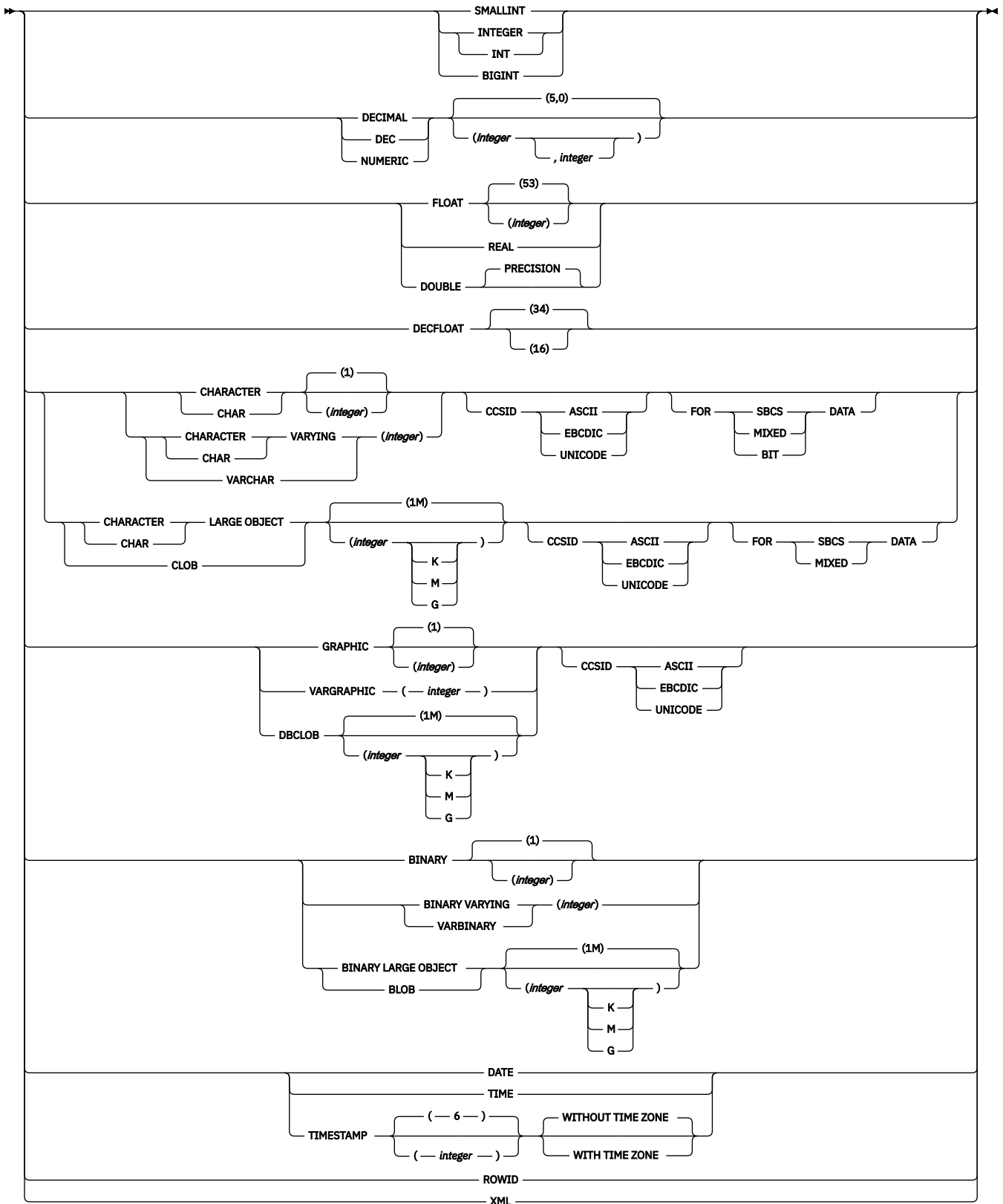

SQL-routine-body:

➤ SQL-control-statement ➤

option-list:

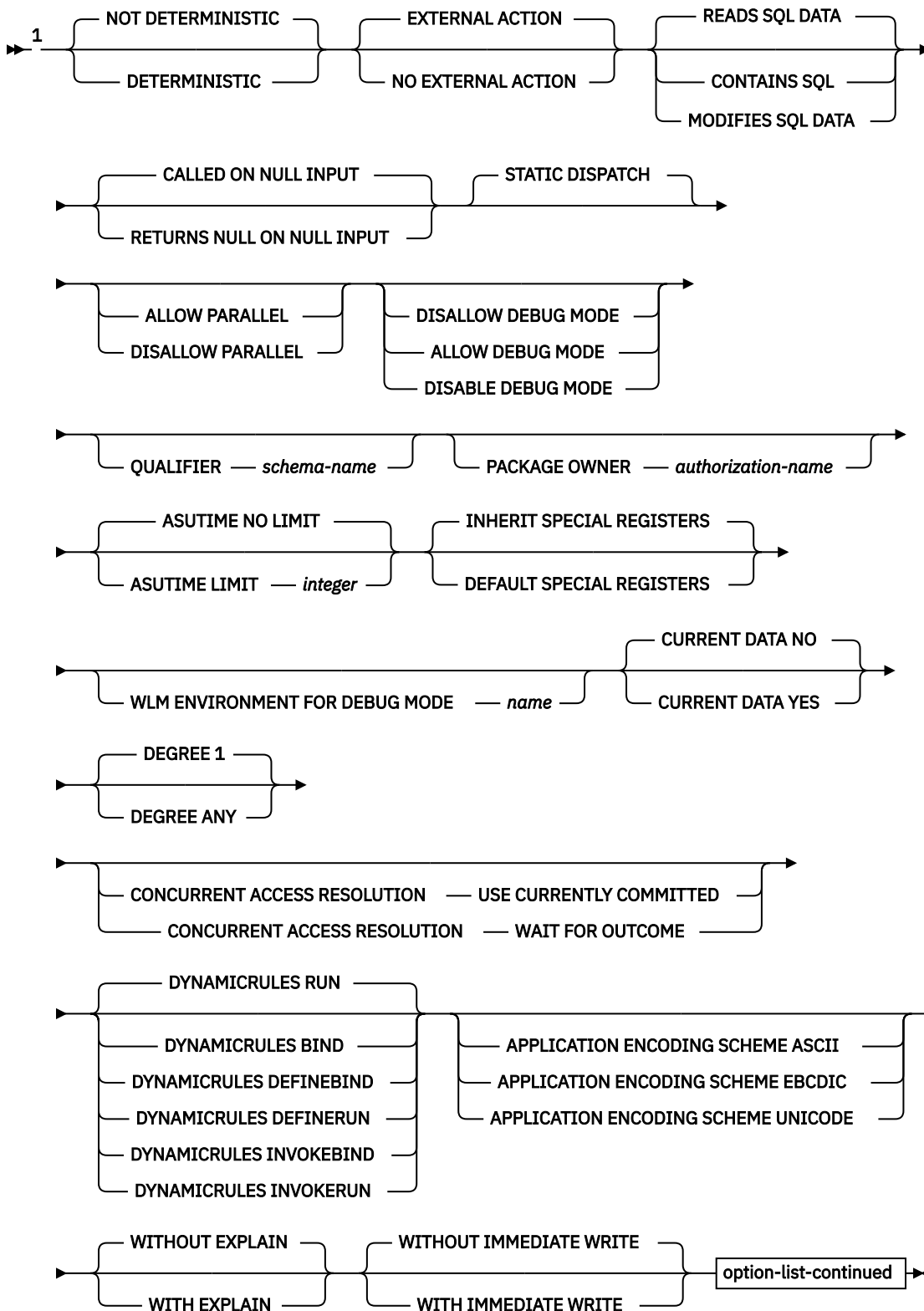

option-list-continued:

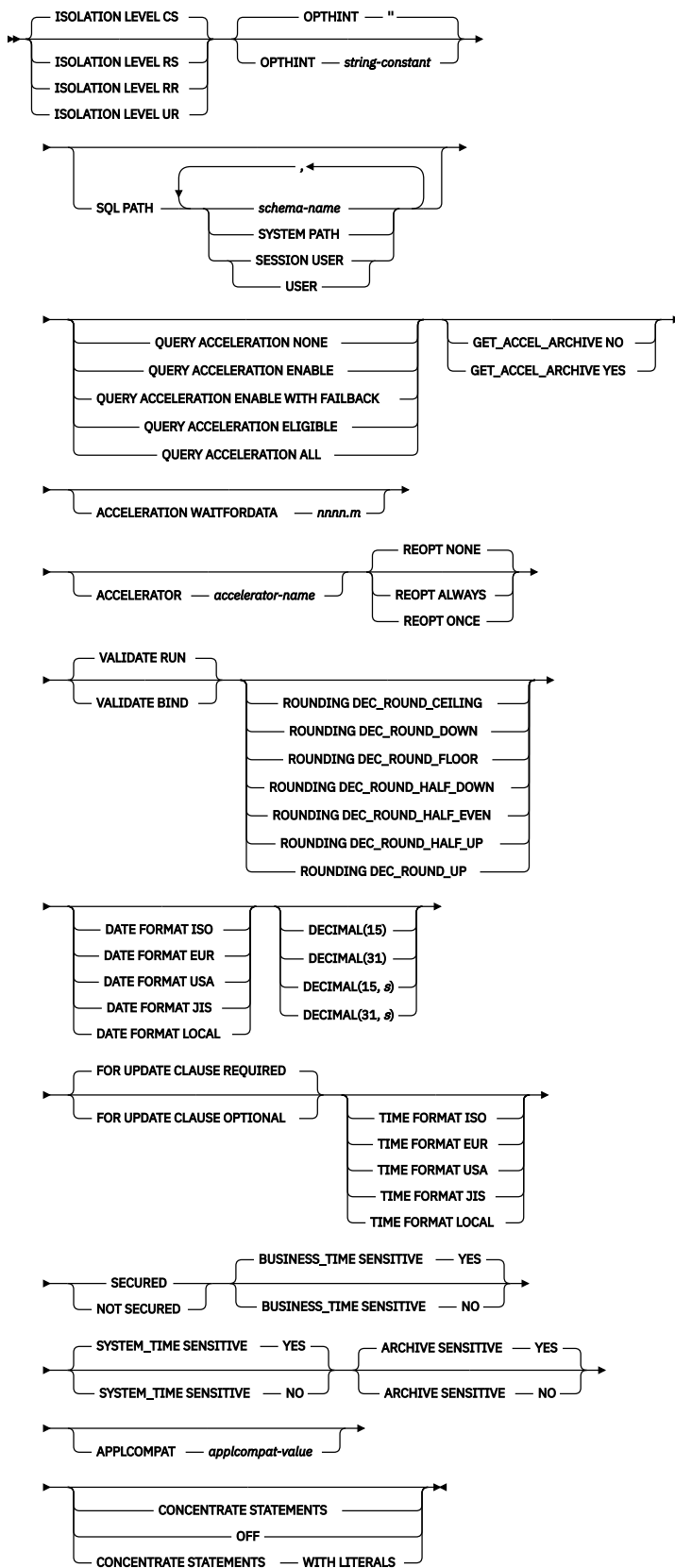

Notes:

¹ Specify options in any order. Specify at least one option. Do not specify the same option more than one time.

Description for ALTER FUNCTION (compiled SQL scalar)

One of the following three clauses identifies the function to be changed.

FUNCTION *function-name*

Identifies the SQL function by its function name.

The identified function must be an SQL scalar function. There must be exactly one function with *function-name* in the schema. The function can have any number of input parameters.²⁴ If the schema does not contain a function with *function-name* or contains more than one function with this name, an error occurs.

The function must not be obfuscated.

FUNCTION *function-name (parameter-type,...)*

Identifies the SQL function by its function signature, which uniquely identifies the function.

function-name

Gives the function name of the SQL function.

If *function-name()* is specified, the function that is identified must have zero parameters.

(parameter-type,...)

Specifies the number of input parameters of the function and the name and data type of each parameter.

If the function was defined with a table parameter (the LIKE TABLE *name* AS LOCATOR clause was specified in the CREATE FUNCTION statement to indicate that one of the input parameters is a transition table), the function signature cannot be used to uniquely identify the function.

Instead, use one of the other syntax variations to identify the function with its function name, if unique, or its specific name.

(data-type,...)

Identifies the number of input parameters of the function and the data type of each parameter. The data type of each parameter must match the data type that was specified in the CREATE FUNCTION statement for the parameter in the corresponding position. The number of data types and the logical concatenation of the data types are used to uniquely identify the function. Therefore, you cannot change the number of parameters or the data types of the parameters.

For data types that have a length, precision, or scale attribute, you can use a set of empty parentheses, specify a value, or accept the default values:

- Empty parentheses indicate that Db2 is to ignore the attribute when determining whether the data types match.

For example, DEC() will be considered a match for a parameter of a function defined with a data type of DEC(7,2). Similarly DECFLOAT() will be considered a match for DECFLOAT(16) or DECFLOAT(34).

FLOAT cannot be specified with empty parentheses because its parameter value indicates different data types (REAL or DOUBLE).

- If you use a specific value for a length, precision, or scale attribute, the value must exactly match the value that was specified (implicitly or explicitly) in the CREATE FUNCTION statement.

The specific value for FLOAT(*n*) does not have to exactly match the defined value of the source function because $1 \leq n \leq 21$ indicates REAL and $22 \leq n \leq 53$ indicates DOUBLE. Matching is based on whether the data type is REAL or DOUBLE.

- If length, precision, or scale is not explicitly specified and empty parentheses are not specified, the default length of the data type is implied. The implicit length must exactly match the value that was specified (implicitly or explicitly) in the CREATE FUNCTION statement.

²⁴ If the function has more than 30 parameters, only the first 30 parameters are used to determine whether the function is unique.

For data types with a subtype or encoding scheme attribute, specifying the FOR *subtype* DATA clause or the CCSID clause is optional. Omission of either clause indicates that Db2 is to ignore the attribute when determining whether the data types match. If you specify either clause, it must match the value that was implicitly or explicitly specified in the CREATE FUNCTION statement.

See “CREATE FUNCTION statement (overview)” on page 1424 for more information on the specification of the parameter list.

A function with the function signature must exist in the explicitly or implicitly specified schema.

SPECIFIC FUNCTION *specific-name*

Identifies a particular user-defined function by its specific name. The name is implicitly or explicitly qualified with a schema name. A compiled SQL scalar function with the specific name must exist in the schema. If the specific name is not qualified, it is implicitly qualified with a schema name as described in the description for FUNCTION *function-name*.

ACTIVE VERSION, ALL VERSION or, VERSION *routine-version-id*

Identifies the version of the function that is to be changed.

ACTIVE VERSION

Specifies that the currently active version of the function is to be changed, replaced, or regenerated. If the function is secure, the changed, replaced, or regenerated version remains secure.

ACTIVE VERSION is the default.

ALL VERSIONS

Specifies that all of the versions of the function are to be changed. SECURED and NOT SECURED are the only options that can be changed when ALL VERSIONS is specified.

VERSION *routine-version-id*

Identifies the version of the function that is to be changed, replaced, or regenerated. *routine-version-id* is the version identifier that is assigned when the version of the function is defined. *routine-version-id* must identify a version of the specified function that exists at the current server. If the function is secure, the changed, replaced, or regenerated version remains secure.

ALTER

Specifies that a version of the function is to be changed. When you change a function using ALTER *option-list*, any option that is not explicitly specified will use the existing value from the version of the function that is being changed.

REPLACE

Specifies that a version of the function is to be replaced.

Binding the replaced version of the function might result in a new access path even if the routine body is not being changed.

When you replace a function, the data types, CCSID specifications, and character data attributes (FOR BIT/SBCS/MIXED DATA) of the parameters must be the same as the attributes of the corresponding parameters for the currently active version of the function. For options that are not explicitly specified, the system default values for those options are used, even if those options were explicitly specified for the version of the function that is being replaced. This is not the case for versions of the function that specified DISABLE DEBUG MODE. If DISABLE DEBUG MODE is specified for a version of a function, it cannot be changed by using the REPLACE clause. When a function definition is replaced, any existing comments in the catalog for that definition of the function are removed.

ADD VERSION *routine-version-id*

Specifies that a new version of the function is to be created. *routine-version-id* is the version identifier for the new version of the function. *routine-version-id* must not identify a version of the specified function that already exists at the current server.

When you add a new version of a function, the data types, CCSID specifications, and character data attributes (FOR BIT/SBCS/MIXED DATA) of the parameters must be the same as the attributes of the corresponding parameters for the currently active version of the function. The parameter names can

differ from the other versions of the function. For options that are not explicitly specified, the system default values will be used.

If the function is secure, the new version is considered secure.

ACTIVATE VERSION *routine-version-id*

Specifies the version of the function that is to be the currently active version. *routine-version-id* is the version identifier that is assigned when the version of the function is defined. The version that is specified with *routine-version-id* is the version that will be invoked by a function invocation. *routine-version-id* must identify a version of the function that exists at the current server.

REGENERATE

Specifies that a version of the function is to be regenerated.

REGENERATE automatically rebinds, at the current server, the package for the SQL control statements for the function and rebinds the package for the SQL statements that are included in the body of the function.

REGENERATE is different than the REBIND PACKAGE command. REBIND PACKAGE rebinds the SQL statements (usually to generate better access paths for those statement) but the SQL control statements in the function definition are not rebound.

When a function definition is regenerated, any existing comments in the catalog for that definition of the function are not removed.

Generally, the REGENERATE keyword is used only for specific situations, such as when implicit regeneration fails for routines or objects, or Db2 maintenance requires objects or routines to be regenerated. For more information, see [When to regenerate Db2 database objects and routines \(Db2 Administration Guide\)](#).

USING APPLICATION COMPATIBILITY *applcompat-level*

Specifies the application compatibility level used to regenerate the version of the procedure. The ALTER statement returns an error if the existing definition of the version includes syntax, semantics or options that require a higher application compatibility level. This situation can occur when the version was most recently defined or regenerated while running at a higher application compatibility level than *applcompat-level*.

The following values can be specified:

VvvRrMmmm

Compatibility with the behavior of the identified Db2 function level. For example, V12R1M510 specifies compatibility with the highest available Db2 12 function level. The equivalent function level or higher must be activated.

For the new capabilities that become available in each application compatibility level, see:

- [SQL changes in Db2 13 application compatibility levels](#)
- [SQL changes in Db2 12 application compatibility levels](#)

Tip: Extra program preparation steps might be required to increase the application compatibility level for applications that use data server clients or drivers to access Db2 for z/OS. For more information, see [Setting application compatibility levels for data server clients and drivers \(Db2 Application programming and SQL\)](#).

V12R1

Compatibility with the behavior of Db2 12 function level 500. This value has the same result as specifying V12R1M500.

V11R1

Compatibility with the behavior of Db2 11 new-function mode. After migration to Db2 12, this value has the same result as specifying V12R1M100. For more information, see [V11R1 application compatibility level \(Db2 Application programming and SQL\)](#)

V10R1

Compatibility with the behavior of DB2 10 new-function mode. For more information, see [V10R1 application compatibility level \(Db2 Application programming and SQL\)](#).

If USING APPLICATION COMPATIBILITY is omitted, the regeneration uses the APPLCOMPAT value of the applicable SYSIBM.SYSPACKAGE catalog table row.

DROP VERSION *routine-version-id*

Drops the version of the function that is identified with *routine-version-id*. *routine-version-id* is the version identifier that is assigned when the version is defined. *routine-version-id* must identify a version of the function that exists at the current server and must not identify the currently active version of the function. Only the identified version of the function is dropped.

When only a single version of the function exists at the current server, use the DROP FUNCTION statement to drop the function.

RETURNS

Identifies the output of the function.

data-type2

Specifies the data type of the output. The data type must match the data type that was specified in the RETURNS clause of the CREATE FUNCTION statement.

NOT DETERMINISTIC or DETERMINISTIC

Specifies whether the function returns the same results each time that the function is invoked with the same input arguments.

NOT DETERMINISTIC

The function might not return the same result each time that the function is invoked with the same input arguments. The function depends on some state values that affect the results. Db2 uses this information to disable the merging of views and table expressions when processing SELECT or SQL data change statements that refer to this function. An example of a function that is not deterministic is one that generates random numbers.

NOT DETERMINISTIC must be specified explicitly or implicitly if the function program accesses a special register or invokes another function that is not deterministic.

DETERMINISTIC

The function always returns the same result each time that the function is invoked with the same input arguments. An example of a deterministic function is a function that calculates the square root of the input. Db2 uses this information to enable the merging of views and table expressions for SELECT or SQL data change statements that refer to this function. If applicable, specify DETERMINISTIC to prevent non-optimal access paths from being chosen for SQL statements that refer to this function.

Db2 does not verify that the function program is consistent with the specification of DETERMINISTIC or NOT DETERMINISTIC.

EXTERNAL ACTION or NO EXTERNAL ACTION

Specifies whether the function takes an action that changes the state of an object that Db2 does not manage. An example of an external action is sending a message or writing a record to a file.

EXTERNAL ACTION

The function can take an action that changes the state of an object that Db2 does not manage.

Some SQL statements that invoke functions with external actions can result in incorrect results if parallel tasks execute the function. For example, if the function sends a note for each initial call to it, one note is sent for each parallel task instead of once for the function.

If you specify EXTERNAL ACTION, Db2:

- Materializes the views and table expressions in SELECT or SQL data change statements that refer to the function. This materialization can adversely affect the access paths that are chosen for the SQL statements that refer to this function. Do not specify EXTERNAL ACTION if the function does not have an external action.

- Does not move the function from one task control block (TCB) to another between FETCH operations.
- Does not allow another function or stored procedure to use the TCB until the cursor is closed. This is also applicable for cursors declared WITH HOLD.

The only changes to resources made outside of Db2 that are under the control of commit and rollback operations are those changes made under RRS control.

EXTERNAL ACTION must be specified implicitly or explicitly specified if the SQL routine body invokes a function that is defined with EXTERNAL ACTION.

NO EXTERNAL ACTION

The function does not take any action that changes the state of an object that Db2 does not manage. Db2 uses this information to enable the merging of views and table expressions for SELECT or SQL data change statements that refer to this function. If applicable, specify NO EXTERNAL ACTION to prevent non-optimal access paths from being chosen for SQL statements that refer to this function.

Db2 does not verify that the function program is consistent with the specification of EXTERNAL ACTION or NO EXTERNAL ACTION.

MODIFIES SQL DATA, READS SQL DATA, or CONTAINS SQL

Specifies the classification of SQL statements and nested routines that this routine can execute or invoke. The database manager verifies that the SQL statements issued by the function, and all routines locally invoked by the routine, are consistent with this specification; the verification is not performed when nested remote routines are invoked. For the classification of each statement, see [Appendix D, “SQL statement data access classification for routines,”](#) on page 2275.

MODIFIES SQL DATA

Specifies that the function can execute any SQL statement except the statements that are not supported in functions. Do not specify MODIFIES SQL DATA when ALLOW PARALLEL is in effect.

If a function that is defined with MODIFIES SQL DATA is invoked anywhere except the *select-clause* of the outermost SELECT statement, the results are unpredictable because the function can be invoked multiple times depending on the access plan that is used.

Recommendation: If a SELECT statement invokes a function that is defined with the MODIFIES SQL DATA option, ensure that statements nested inside the function do not modify objects that are referenced in any SQL statement at a higher level of nesting. Otherwise, unpredictable results are likely to occur.

READS SQL DATA

Specifies that the function can execute statements with a data access classification of READS SQL DATA, CONTAINS SQL, or NO SQL. The function cannot execute SQL statements that modify data.

READS SQL DATA is the default.

CONTAINS SQL

Specifies that the function can execute only SQL statements with a data access classification of CONTAINS SQL or NO SQL. The function cannot execute SQL statements the read or modify data.

CALLED ON NULL INPUT or RETURNS NULL ON NULL INPUT

Specifies whether the function is invoked if any of the input arguments is null at execution time.

CALLED ON NULL INPUT

Specifies that the function is to be invoked, if any, or all, argument values are null. This specification means that the body of the function must be coded to test for null argument values.

CALLED ON NULL INPUT is the default.

RETURNS NULL ON NULL INPUT

Specifies that the function is not invoked and returns the null value if any of the input arguments is null.

STATIC DISPATCH

At function resolution time, Db2 chooses a function based on the static (or declared) types of the function parameters.

STATIC DISPATCH is the default.

ALLOW PARALLEL or DISALLOW PARALLEL

Specifies if the function can be run in parallel. The default is `DISALLOW PARALLEL`, if you specify one or more of the following clauses:

- `NOT DETERMINISTIC`
- `EXTERNAL ACTION`
- `MODIFIES SQL DATA`

Otherwise, `ALLOW PARALLEL` is the default.

ALLOW PARALLEL

Specifies that the function can be run in parallel.

DISALLOW PARALLEL

Specifies that the function cannot be run in parallel.

ALLOW DEBUG MODE, DISALLOW DEBUG MODE, or DISABLE DEBUG MODE

Specifies whether this version of the routine can be run in debugging mode. The default is determined using the value of the `CURRENT DEBUG MODE` special register.

ALLOW DEBUG MODE

Specifies that this version of the routine can be run in debugging mode. When this version of the routine is invoked and debugging is attempted, a WLM environment must be available.

DISALLOW DEBUG MODE

Specifies that this version of the routine cannot be run in debugging mode.

You can use an `ALTER` statement to change this option to `ALLOW DEBUG MODE` for this initial version of the routine.

DISABLE DEBUG MODE

Specifies that this version of the routine can never be run in debugging mode.

This version of the routine cannot be changed to specify `ALLOW DEBUG MODE` or `DISALLOW DEBUG MODE` after this version of the routine has been created or altered to use `DISABLE DEBUG MODE`. To change this option, drop the routine and create it again using the option that you want. An alternative to dropping and recreating the routine is to create a version of the routine that uses the option that you want and making that version the active version.

When `DISABLE DEBUG MODE` is in effect, the `WLM ENVIRONMENT FOR DEBUG MODE` is ignored.

QUALIFIER *schema-name*

Specifies the implicit qualifier that is used for unqualified object names that are referenced in the procedure body. For information about how the default for this option is determined, see [“Unqualified alias, index, JAR file, mask, permission, sequence, table, trigger, and view names”](#) on page 86.

PACKAGE OWNER *authorization-name*

Specifies the owner of the package that is associated with the version of the routine. The SQL authorization ID of the process is the default value.

ASUTIME

Specifies the total amount of processor time, in CPU service units, that a single invocation of a routine can run. The value is unrelated to the `ASUTIME` column of the resource limit specification table.

When you are debugging a routine, setting a limit can be helpful in case the routine gets caught in a loop. For information on service units, see [z/OS MVS Initialization and Tuning Guide](#).

NO LIMIT

Specifies that there is no limit on the service units.

NO LIMIT is the default.

LIMIT *integer*

The limit on the number of CPU service units is a positive *integer* in the range 1–2 147 483 647. If the procedure uses more service units than the specified value, Db2 cancels the procedure. The CPU cycles that are consumed by parallel tasks in a procedure do not contribute towards the specified ASUTIME LIMIT.

INHERIT SPECIAL REGISTERS or DEFAULT SPECIAL REGISTERS

Specifies how special registers are set on entry to the routine.

INHERIT SPECIAL REGISTERS

Specifies that the values of special registers are inherited, according to the rules that are listed in the table for characteristics of special registers in a routine in [Table 47 on page 215](#).

INHERIT SPECIAL REGISTERS is the default.

DEFAULT SPECIAL REGISTERS

Specifies that special registers are initialized to the default values, as indicated by the rules in the table for characteristics of special registers in a routine in [Table 47 on page 215](#).

WLM ENVIRONMENT FOR DEBUG MODE *name*

Specifies the WLM (workload manager) application environment that is used by Db2 when debugging the routine. The *name* of the WLM environment is an SQL identifier.

If you do not specify WLM ENVIRONMENT FOR DEBUG MODE, Db2 uses the default WLM-established stored procedure address space specified at installation time.

You must have the appropriate authority for the WLM application environment.

The WLM ENVIRONMENT FOR DEBUG MODE value is ignored when DISABLE DEBUG MODE is in effect.

CURRENT DATA YES or CURRENT DATA NO

Specifies whether to require data currency for read-only and ambiguous cursors when the isolation level of cursor stability is in effect. CURRENT DATA also determines whether block fetch can be used for distributed, ambiguous cursors.

CURRENT DATA YES

Specifies that data currency is required for read-only and ambiguous cursors. Db2 acquires page or row locks to ensure data currency. Block fetch is ignored for distributed, ambiguous cursors.

CURRENT DATA NO

Specifies that data currency is not required for read-only and ambiguous cursors. Block fetch is allowed for distributed, ambiguous cursors. Use of CURRENT DATA NO is not recommended if the routine attempts to dynamically prepare and execute a DELETE WHERE CURRENT OF statement against an ambiguous cursor after that cursor is opened. You receive a negative SQLCODE if your routine attempts to use a DELETE WHERE CURRENT OF statement for any of the following cursors:

- A cursor that is using block fetch
- A cursor that is using query parallelism
- A cursor that is positioned on a row that is modified by this or another application process

CURRENT DATA NO is the default.

DEGREE

Specifies whether to attempt to run a query using parallel processing to maximize performance.

1

Specifies that parallel processing should not be used.

1 is the default.

ANY

Specifies that parallel processing can be used.

CONCURRENT ACCESS RESOLUTION

Specifies the whether processing uses only committed data or whether it will wait for commit or rollback of data that is in the process of being updated.

WAIT FOR OUTCOME

Specifies that processing will wait for the commit or rollback of data that is in the process of being updated.

USE CURRENTLY COMMITTED

Specifies that processing use the currently committed version of the data when data that is in the process of being updated is encountered. USE CURRENTLY COMMITTED is applicable on scans that access tables that are defined in universal table spaces with row or page level lock size.

When there is lock contention between a read transaction and an insert transaction, USE CURRENTLY COMMITTED is applicable to scans with isolation level CS or RS. Applicable scans include intent read scans for read-only and ambiguous queries and for updatable cursors. USE CURRENTLY COMMITTED is also applicable to scans initiated from WHERE predicates of UPDATE or DELETE statements and the subselect of INSERT statements.

When there is lock contention is between a read transaction and a delete transaction, USE CURRENTLY COMMITTED is applicable to scans with isolation level CS and when CURRENT DATA NO is specified.

DYNAMICRULES

Specifies the values that apply, at run time, for the following dynamic SQL attributes:

- The authorization ID that is used to check authorization
- The qualifier that is used for unqualified objects
- The source for application programming options that Db2 uses to parse and semantically verify dynamic SQL statements

DYNAMICRULES also specifies whether dynamic SQL statements can include GRANT, REVOKE, ALTER, CREATE, DROP, and RENAME statements.

In addition to the value of the DYNAMICRULES clause, the run time environment of a routine controls how dynamic SQL statements behave at run time. The combination of the DYNAMICRULES value and the run time environment determines the value for the dynamic SQL attributes. That set of attribute values is called the dynamic SQL statement behavior. The following values can be specified:

RUN

Specifies that dynamic SQL statements are to be processed using run behavior.

RUN is the default.

BIND

Specifies that dynamic SQL statements are to be processed using bind behavior.

DEFINEBIND

Specifies that dynamic SQL statements are to be processed using either define behavior or bind behavior.

DEFINERUN

Specifies that dynamic SQL statements are to be processed using either define behavior or run behavior.

INVOKEBIND

Specifies that dynamic SQL statements are to be processed using either invoke behavior or bind behavior.

INVOKERUN

Specifies that dynamic SQL statements are to be processed using either invoke behavior or run behavior.

See For information on the effects of these options, see [“Authorization IDs and dynamic SQL”](#) on page 94.

APPLICATION ENCODING SCHEME

Specifies the default encoding scheme for SQL variables in static SQL statements in the routine body. The value is used for defining an SQL variable in a compound statement if the CCSID clause is not specified as part of the data type, and the PARAMETER CCSID routine option is not specified.

ASCII

Specifies that the data is encoded using the ASCII CCSIDs of the server.

EBCDIC

Specifies that the data is encoded using the EBCDIC CCSIDs of the server.

UNICODE

Specifies that the data is encoded using the Unicode CCSIDs of the server.

See the `ENCODING` bind option in [ENCODING bind option \(Db2 Commands\)](#) for information about how the default for this option is determined.

WITH EXPLAIN or WITHOUT EXPLAIN

Specifies whether information will be provided about how SQL statements in the routine will execute.

WITHOUT EXPLAIN

Specifies that information will not be provided about how SQL statements in the routine will execute.

You can get EXPLAIN output for a statement that is embedded in a routine that is specified using `WITHOUT EXPLAIN` by embedding the SQL statement `EXPLAIN` in the routine body. Otherwise, the value of the `EXPLAIN` option applies to all explainable SQL statements in the routine body, and to the `fullselect` portion of any `DECLARE CURSOR` statements.

`WITHOUT EXPLAIN` is the default.

WITH EXPLAIN

Specifies that information will be provided about how SQL statements in the routine will execute. Information is inserted into the table `owner.PLAN_TABLE`. `owner` is the authorization ID of the owner of the routine. Alternatively, the authorization ID of the owner of the routine can have an alias as `owner.PLAN_TABLE` that points to the base table, `PLAN_TABLE`. `owner` must also have the appropriate `SELECT` and `INSERT` privileges on that table. `WITH EXPLAIN` does not obtain information for statements that access remote objects. `PLAN_TABLE` must have a base table and can have multiple aliases with the same table name, `PLAN_TABLE`, but have different schema qualifiers. It cannot be a view or a synonym and should exist before the `CREATE` statement is processed. In all inserts to `owner.PLAN_TABLE`, the value of `QUERYNO` is the statement number that is assigned by Db2.

The `WITH EXPLAIN` option also populates two optional tables, if they exist: `DSN_STATEMNT_TABLE` and `DSN_FUNCTION_TABLE`. `DSN_STATEMNT_TABLE` contains an estimate of the processing cost for an SQL statement and `DSN_FUNCTION_TABLE` contains information about function resolution. For more information, see [EXPLAIN tables \(Db2 Performance\)](#).

For more information about the `EXPLAIN` statement, including a description of the tables that are populated by the `WITH EXPLAIN` option, see [“EXPLAIN statement” on page 1917](#).

WITH IMMEDIATE WRITE or WITHOUT IMMEDIATE WRITE

Specifies whether immediate writes are to be done for updates that are made to group buffer pool dependent page sets or partitions. This option is only applicable for data sharing environments. The `IMMEDWRITE` subsystem parameter has no affect of this option. `IMMEDWRITE bind option (Db2 Commands)` shows the implied hierarchy of the `IMMEDWRITE` bind option (which is similar to this routine option) as it affects run time.

WITHOUT IMMEDIATE WRITE

Specifies that normal write activity is performed. Updated pages that are group buffer pool dependent are written at or before phase one of commit or at the end of abort for transactions that have been rolled back.

`WITHOUT IMMEDIATE WRITE` is the default.

WITH IMMEDIATE WRITE

Specifies that updated pages that are group buffer pool dependent are immediately written as soon as the buffer update completes. Updated pages are written immediately even if the buffer

is updated during forward progress or during the rollback of a transaction. WITH IMMEDIATE WRITE might impact performance.

ISOLATION LEVEL RR, RS, CS, or UR

Specifies how far to isolate the routine from the effects of other running applications. For information about isolation levels, see [Choosing an ISOLATION option \(Db2 Performance\)](#).

RR

Specifies repeatable read.

RS

Specifies read stability.

CS

Specifies cursor stability. CS is the default.

UR

Specifies uncommitted read.

OPHTINT '*hint-id*'

Specifies whether query optimization hints are used for static SQL statements that are contained within the body of the routine.

hint-id is a character string of up to 128 bytes in length, which is used by the Db2 subsystem when searching the PLAN_TABLE for rows to use as input. The default value is an empty string (''), which indicates that the Db2 subsystem does not use optimization hints for static SQL statements.

Optimization hints are only used if optimization hints are enabled for your system. For more information, see [OPTIMIZATION HINTS field \(OPHTINTS subsystem parameter\) \(Db2 Installation and Migration\)](#).

SQL PATH

Specifies the SQL path that the Db2 subsystem uses to resolve unqualified user-defined types, functions, and procedure names (in CALL statements) in the body of the routine. The default value is "SYSIBM", "SYSFUN", "SYSPROC", "SYSIBMADM", and the value of the QUALIFIER option, which is the qualifier for the trigger that is the target of the statement. The maximum length of the SQL path is 2048 bytes. Db2 calculates the length by taking each *schema-name* that is specified and removing any trailing blanks from it, adding two delimiters around it, and adding one comma after each schema name except for the last name. The length of the resulting string cannot exceed 2048 bytes.

schema-name

Identifies a schema. Db2 does not verify that the schema exists when the ALTER statement is processed. The same schema name should not appear more than one time in the list of schema names.

SYSPUBLIC must not be specified for the SQL path.

SYSTEM PATH

Specifies the schema names "SYSIBM", "SYSFUN", "SYSPROC", "SYSIBMADM".

SESSION_USER or USER

Specifies the value of the SESSION_USER (or USER) special register. At the time the ALTER statement is processed, the actual length is included in the total length of the list of schema names that is specified for the SQL PATH option.

REOPT

Specifies if Db2 will determine the access path at run time by using the values of SQL variables or SQL parameters, parameter markers, and special registers.

NONE

Specifies that Db2 does not determine the access path at run time by using the values of SQL variables or SQL parameters, parameter markers, and special registers.

NONE is the default.

ALWAYS

Specifies that Db2 always determines the access path at run time each time an SQL statement is run. Do not specify REOPT ALWAYS with the WITH KEEP DYNAMIC or NODEFER PREPARE clauses.

ONCE

Specifies that Db2 determine the access path for any dynamic SQL statements only once, at the first time the statement is opened. This access path is used until the prepared statement is invalidated or removed from the dynamic statement cache and need to be prepared again.

QUERY ACCELERATION

Specifies whether a static SQL query is bound for acceleration, and if so, with what behavior.

NONE

Specifies that no static SQL query in the application is bound for acceleration or will be accelerated when the application is run.

ENABLE

Specifies that a static SQL query is bound for acceleration if it satisfies the acceleration criteria, including the cost and heuristics criteria. The query is routed to an accelerator when the application runs. Otherwise, if the static query does not satisfy the acceleration criteria, the query is bound for execution in Db2.

If an error condition, such as one of the following examples, occurs while executing the accelerated static query when the application is run, Db2 fails the static query and returns a negative SQL code to the application:

- A failure occurs while running the static query on the accelerator.
- The accelerator returns an error for the query.
- The accelerator is not started and Db2 cannot route the static query to the accelerator for execution.

ENABLE WITH FAILBACK

Results in the same behavior as ENABLE, except if one of the error conditions occurs on the first OPEN of the accelerated static query when the application is run. In this case, instead of failing the static query and returning a negative SQL code to the application, Db2 performs a temporary *statement-level* incremental bind of the query and runs the query in Db2. The application does not see the acceleration failure. Failback to Db2 is not possible after the application does a successful OPEN for the query on the accelerator.

ELIGIBLE

Specifies that a static SQL query is bound for acceleration if the query meets the basic acceleration criteria, regardless of the cost or heuristics criteria. The query is routed to the accelerator when the application runs.

Like the behavior for ENABLE, if an error condition occurs while executing the accelerated static query when the application is run, Db2 fails the static query and returns a negative SQL code to the application.

ALL

Specifies that all of the static SQL queries in the application are to be bound for acceleration and routed to the accelerator when the application runs. If Db2 determines that a static query cannot be bound to run on the accelerator and the query references a user base table or view, the BIND or REBIND PACKAGE operation fails with an error message for that query. (A failure exception is made for declared global temporary tables (DGTTs) and created global temporary tables and (CGTTs) because these tables cannot be accelerated.)

Like the behavior for ENABLE, if an error condition occurs while executing the accelerated static query when the application is run, Db2 fails the static query and returns a negative SQL code to the application.

This bind option does not apply to a *fullselect* or WITH *common-table-expression* that is specified in a RETURN statement for the routine, or in a SET *host-variable-assignment* that is used in the routine. The queries that are specified in these cases cannot be accelerated.

GET_ACCEL_ARCHIVE

Specifies whether a static SQL query that is bound for acceleration retrieves archived data on the accelerator, instead of active data.

NO

Specifies that no static SQL query is bound to retrieve archived data from the accelerator. If the static query also is not bound for acceleration, the query is bound to run in Db2.

If the static query is bound for acceleration because the QUERYACCELERATION bind option was specified, the query is routed to the accelerator when the application runs; however, the query does not retrieve any archived data.

YES

Specifies that if all of the following criteria are met, the query is bound for acceleration and retrieves the archived data on the accelerator when the application runs:

- The QUERYACCELERATION bind option is also specified.
- The static SQL query references an accelerated table that has partitioned data archived on an accelerator.
- The static query satisfies the acceleration criteria that is specified by the QUERYACCELERATION bind option.

If the static query does not satisfy the acceleration criteria that is specified by the QUERYACCELERATION bind option, the BIND or REBIND PACKAGE operation fails with an error message for that query.

This bind option does not apply to a *fullselect* or *WITH common-table-expression* that is specified in a RETURN statement for the routine, or in a SET *host-variable-assignment* that is used in the routine. The queries that are specified in these cases cannot be accelerated.

ACCELERATION WAITFORDATA

Specifies the maximum amount of time, if any, that an accelerator will delay a query while the accelerator waits for the replication of committed Db2 data changes that occurred prior to Db2 running the query.

For static accelerated queries, you must also set the QUERYACCELERATION bind option for this function or procedure to a valid value other than NONE to request that static queries be accelerated. If the QUERYACCELERATION bind option value is set to NONE, the ACCELERATIONWAITFORDATA bind option is accepted and the package is bound with the option value; however, the option will not apply to static SQL queries because no static queries will be accelerated.

For dynamic accelerated queries, specifying the ACCELERATION WAITFORDATA bind option also initializes the CURRENT QUERY ACCELERATION WAITFORDATA special register, which is used for the dynamic queries in the Db2 function or procedure if the function or procedure option DEFAULT SPECIAL REGISTERS is also used. Initializing CURRENT QUERY ACCELERATION WAITFORDATA to a value greater than 0 specifies that Db2 and the accelerator will apply WAITFORDATA delay behavior and restrictions to all dynamic SQL queries to be accelerated from the Db2 function or procedure. The CURRENT QUERY ACCELERATION special register must also have a valid value other than NONE to request that dynamic queries be accelerated.

nnnn.m

Specifies a DECIMAL(5,1) numeric-constant value that specifies the maximum number of seconds that the accelerator will delay a query while the accelerator waits for the replication of committed Db2 data changes that occurred prior to Db2 running the query.

You can specify a value in the range of 0.0–3600.0 seconds. For example, a value of 20.0 represents 20.0 seconds (or 20000 milliseconds), and a value of 30.5 represents 30.5 seconds (or 30500 milliseconds). The maximum value of 3600.0 means they the query is delayed for 3600 seconds.

You can also specify the value as an INTEGER numeric-constant value ranging 0–3600 seconds, which Db2 will convert to a DECIMAL(5,1) value.

Important: When a non-zero value is specified for the ACCELERATIONWAITFORDATA bind option, Db2 and the accelerator will apply other WAITFORDATA delay behaviors, restrictions, and requirements to all queries that will be accelerated from the application package. These behaviors, restrictions, and requirements can cause queries that were formerly accelerated successfully to no longer be accelerated or to fail. See [“SET CURRENT QUERY ACCELERATION WAITFORDATA statement”](#) on page 2150 for more information about WAITFORDATA behaviors, restrictions, and requirements.

ACCELERATOR

Specifies an accelerator server that, if enabled and available, Db2 will consider as the preferred accelerator for eligible SQL queries before sending the queries to other accelerator servers. If the specified accelerator server is not enabled or available, Db2 will send the queries to other available accelerator servers.

VALIDATE RUN or VALIDATE BIND

Specifies whether to recheck, at run time, errors of the type "OBJECT NOT FOUND" and "NOT AUTHORIZED" that are found during bind or rebind. The option has no effect if all objects and needed privileges exist.

VALIDATE RUN

Specifies that if needed objects or privileges do not exist when the CREATE statement is processed, warning messages are returned, but the CREATE statement succeeds. The Db2 subsystem rechecks for the objects and privileges at run time for those SQL statements that failed the checks during processing of the CREATE statement. The authorization checks the use of the authorization ID of the owner of the routine.

VALIDATE RUN is the default.

VALIDATE BIND

Specifies that if needed objects or privileges do not exist at the time the CREATE statement is processed, an error is issued and the CREATE statement fails.

ROUNDING

Specifies the rounding mode for manipulation of DECFLOAT data. The default value is taken from the DEFAULT DECIMAL FLOATING POINT ROUNDING MODE in DECP.

DEC_ROUND_CEILING

Specifies numbers are rounded towards positive infinity.

DEC_ROUND_DOWN

Specifies numbers are rounded towards 0 (truncation).

DEC_ROUND_FLOOR

Specifies numbers are rounded towards negative infinity.

DEC_ROUND_HALF_DOWN

Specifies numbers are rounded to nearest; if equidistant, round down.

DEC_ROUND_HALF_EVEN

Specifies numbers are rounded to nearest; if equidistant, round so that the final digit is even.

DEC_ROUND_HALF_UP

Specifies numbers are rounded to nearest; if equidistant, round up.

DEC_ROUND_UP

Specifies numbers are rounded away from 0.

DATE FORMAT ISO, EUR, USA, JIS, or LOCAL

Specifies the date format for result values that are string representations of date or time values. For more information, see [“String representations of datetime values”](#) on page 120.

The default format is specified in the DATE FORMAT field of installation panel DSNTIP4 of the system where the routine is defined. You cannot use the LOCAL option unless you have a date exit routine.

DECIMAL (15), DECIMAL (31), DECIMAL (15, s), or DECIMAL (31, s)

Specifies the maximum precision that is to be used for decimal arithmetic operations. For more information see [“Arithmetic with two decimal operands”](#) on page 251. The default format is specified

in the DECIMAL ARITHMETIC field of installation panel DSNTIPF of the system where the routine is defined. If the form *pp.s* is specified, *s* must be a number in the range 1–9. *s* represents the minimum scale that is to be used for division.

FOR UPDATE CLAUSE OPTIONAL or FOR UPDATE CLAUSE REQUIRED

Specifies whether the FOR UPDATE clause is required for a DECLARE CURSOR statement if the cursor is to be used to perform positioned updates.

FOR UPDATE CLAUSE REQUIRED

Specifies that a FOR UPDATE clause must be specified as part of the cursor definition if the cursor will be used to make positioned updates.

FOR UPDATE CLAUSE REQUIRED is the default.

FOR UPDATE CLAUSE OPTIONAL

Specifies that the FOR UPDATE clause does not need to be specified in order for a cursor to be used for positioned updates. The routine body can include positioned UPDATE statements that update columns that the user is authorized to update.

The FOR UPDATE clause with no column list applies to static or dynamic SQL statements. Even if you do not use this clause, you can specify FOR UPDATE OF with a column list to restrict updates to only the columns that are identified in the FOR UPDATE clause and to specify the acquisition of update locks.

TIME FORMAT ISO, EUR, USA, JIS, or LOCAL

Specifies the time format for result values that are string representations of date or time values. For more information, see [“String representations of datetime values” on page 120](#).

The default format is specified in the TIME FORMAT field of installation panel DSNTIP4 of the system where the routine is defined. You cannot use the LOCAL option unless you have a date exit routine.

SECURED or NOT SECURED

Specifies if the function is considered secure. When the option is specified with the ALL VERSIONS clause, it applies to all existing versions and to any future versions of the function. When it is specified with other clauses such as ADD VERSION, or REPLACE, the value must be the same as the value that is in effect for the function that is being changed.

SECURED

Specifies that the function is considered secure.

Use of this clause or keyword might invalidate packages that depend on the target object, or packages that depend on related objects through cascading effects. See [Changes that invalidate packages \(Db2 Application programming and SQL\)](#).

NOT SECURED

Specifies that the function is considered not secure. NOT SECURED must not be specified when a row permission or a column mask depends on the function.

When the function is invoked, the arguments of the function must not reference a column for which a column mask is enabled when the table is using active column access control.

Use of this clause or keyword might invalidate packages that depend on the target object, or packages that depend on related objects through cascading effects. See [Changes that invalidate packages \(Db2 Application programming and SQL\)](#).

BUSINESS_TIME SENSITIVE

Determines whether references to application-period temporal tables in both static and dynamic SQL statements are affected by the value of the CURRENT TEMPORAL BUSINESS_TIME special register.

YES

References to application-period temporal tables are affected by the value of the CURRENT TEMPORAL BUSINESS_TIME special register. YES is the default value.

NO

References to application-period temporal tables are not affected by the value of the CURRENT TEMPORAL BUSINESS_TIME special register.

For more information, see [“CURRENT TEMPORAL BUSINESS_TIME special register”](#) on page 208.

SYSTEM_TIME SENSITIVE

Determines whether references to system-period temporal tables in both static and dynamic SQL statements are affected by the value of the CURRENT TEMPORAL SYSTEM_TIME special register.

YES

References to system-period temporal tables are affected by the value of the CURRENT TEMPORAL SYSTEM_TIME special register. YES is the default value.

NO

References to system-period temporal tables are not affected by the value of the CURRENT TEMPORAL SYSTEM_TIME special register.

For more information, see [“CURRENT TEMPORAL SYSTEM_TIME special register”](#) on page 210.

ARCHIVE SENSITIVE

Determines whether references to archive-enabled tables in SQL statements are affected by the value of the SYSIBMADM.GET_ARCHIVE built-in global variable.

YES

References to archive-enabled tables are affected by the value of the SYSIBMADM.GET_ARCHIVE built-in global variable. YES is the default value.

NO

References to archive-enabled tables are not affected by the value of the SYSIBMADM.GET_ARCHIVE built-in global variable. For more information, see [“GET_ARCHIVE”](#) on page 330.

APPLCOMPAT *applcompat-level*

Specifies the application compatibility level behavior for static SQL statements in the function body. If this option is not specified then the behavior is determined, in priority order, by the *applcompat-level* of the previous bind of the package if one exists, or the APPLCOMPAT subsystem parameter.

The following *applcompat-level* values can be specified:

VvvRrMmmm

Compatibility with the behavior of the identified Db2 function level. For example, V12R1M510 specifies compatibility with the highest available Db2 12 function level. The equivalent function level or higher must be activated.

For the new capabilities that become available in each application compatibility level, see:

- [SQL changes in Db2 13 application compatibility levels](#)
- [SQL changes in Db2 12 application compatibility levels](#)

Tip: Extra program preparation steps might be required to increase the application compatibility level for applications that use data server clients or drivers to access Db2 for z/OS. For more information, see [Setting application compatibility levels for data server clients and drivers \(Db2 Application programming and SQL\)](#).

V12R1

Compatibility with the behavior of Db2 12 function level 500. This value has the same result as specifying V12R1M500.

V11R1

Compatibility with the behavior of Db2 11 new-function mode. After migration to Db2 12, this value has the same result as specifying V12R1M100. For more information, see [V11R1 application compatibility level \(Db2 Application programming and SQL\)](#)

V10R1

Compatibility with the behavior of DB2 10 new-function mode. For more information, see [V10R1 application compatibility level \(Db2 Application programming and SQL\)](#).

CONCENTRATE STATEMENTS OFF or CONCENTRATE STATEMENTS WITH LITERALS

Specifies whether each dynamic SQL statement in the routine that specifies literal constants will be cached as a separate unique statement entry in the dynamic statement cache, instead of sharing an existing statement in the cache. Dynamic SQL statements are eligible to share an existing statement in the cache if the new statement meets all of the conditions for sharing a cached version of the same dynamic statement, except that the new statement specifies one or more literal constants that are different than the cached statement.

CONCENTRATE STATEMENTS OFF

Specifies that each dynamic SQL statement that specifies literal constants will be cached as a unique statement entry if it specifies one or more constants that are different than the cached version of the same dynamic statement. **CONCENTRATE STATEMENTS OFF** is the default dynamic statement caching behavior.

CONCENTRATE STATEMENTS WITH LITERALS

Specifies that each dynamic SQL statement that specifies literal constants will share a cached version of the same dynamic statement that is also prepared using the **CONCENTRATE STATEMENTS WITH LITERALS** option, if the new dynamic statement meets all of the conditions for sharing the cached statement, and the constants that are specified can be reused in place of the constants in the cached statement.

SQL-routine-body

Specifies a single SQL control statement, including a compound-statement. See [Chapter 8, “SQL procedural language \(SQL PL\),” on page 2207](#) for more information about defining SQL functions.

A call to a procedure that issues a COMMIT, ROLLBACK, CONNECT, RELEASE, or SET CONNECTION statement is not allowed in a function.

If the *SQL-routine-body* is a compound statement, it must contain at least one RETURN statement and a RETURN statement must be executed when the function is invoked.

An ALTER FUNCTION (compiled SQL scalar) statement or an ALTER PROCEDURE (SQL native) statement with an ADD VERSION or REPLACE clause is not allowed in an *SQL-routine-body*.

Notes for ALTER FUNCTION (compiled SQL scalar)

The order of options and the RETURNS clause

The RETURNS clause must precede the *options-list*. If the body of the function contains only a *RETURN-statement*, *RETURN-statement* must be specified after the RETURNS clause and the *options-list* in the routine body.

ALTER FUNCTION for in use functions:

ALTER FUNCTION will be locked out from making changes if the function is in use. For example, if a query that is currently running is referencing an SQL scalar function named 'fn1' (*routine-version-id* is 'v1'), an ALTER FUNCTION fn1 ACTIVATE VERSION v2 statement will wait for the query that is currently running to complete before making 'v2' the active version for function 'fn1'. This wait for completion behavior happens even if the query invokes the function multiple times for processing multiple rows or if the query contains multiple references to the function that is being changed.

Considerations for changing a version of a function:

To change a version of a function, the environment settings that are in effect when the ALTER FUNCTION statement is issued must be the same as the environment settings that are in effect when the version of the function is first created using the CREATE FUNCTION or ALTER FUNCTION statement if one of the following options is specified:

- QUALIFIER
- PACKAGE OWNER
- WLM ENVIRONMENT FOR DEBUG MODE
- OPTHINT
- SQL PATH

- DECIMAL (if the value includes a comma)

Considerations for catalog comments for a routine definition:

When a function definition is replaced, any existing comment in the catalog for the definition is removed. However, when a function definition is regenerated, any existing comment in the catalog for the definition is retained.

Identifier resolution

See Chapter 8, “SQL procedural language (SQL PL),” on page 2207 for information on how names are resolved to columns, variables, or SQL parameters within an SQL routine.

If duplicate names are used for columns, variables, and parameters, qualify the duplicate names by using the table designator for columns, the routine name for parameters, the label name for SQL variables, and the schema name for global variables.

Characteristics of the package that is generated for a function:

The package that is associated with a version of a function is named as follows:

- *location* is set to the value of the CURRENT SERVER special register
- *collection-id* (schema) for the package is the same as the schema qualifier of the function
- *package-id* is the same as the specific name of the function
- *version-id* is the same as the version identifier for the version of the function

The package is generated using the bind options that correspond to the implicitly or explicitly specified function options. In addition to the corresponding bind options, the package is generated using the following bind options:

- FLAG(I)
- SQLERROR(NOPACKAGE)
- ENABLE(*)

Correspondence of function options to bind command options:

The following table lists options for CREATE FUNCTION and ALTER FUNCTION and the corresponding bind command option. See BIND and REBIND options for packages, plans, and services (Db2 Commands) for information about the BIND command options.

<i>Table 172. Correspondence of function options to bind options</i>	
CREATE FUNCTION or ALTER FUNCTION option	bind command option
ACCELERATION WAITFOR DATA <i>nnnn.m</i>	ACCELERATIONWAITFOR DATA(<i>nnnn.m</i>)
ACCELERATOR <i>accelerator-name</i>	ACCELERATOR(<i>accelerator-name</i>)
APPLICATION ENCODING SCHEME ASCII	ENCODING(ASCII)
APPLICATION ENCODING SCHEME EBCDIC	ENCODING(EBCDIC)
APPLICATION ENCODING SCHEME UNICODE	ENCODING(UNICODE)
ARCHIVE SENSITIVE NO	ARCHIVESENSITIVE(NO)
ARCHIVE SENSITIVE YES	ARCHIVESENSITIVE(YES)
BUSINESS_TIME SENSITIVE NO	BUSTIMESENSITIVE(NO)
BUSINESS_TIME SENSITIVE YES	BUSTIMESENSITIVE(YES)
CURRENT DATA NO	CURRENTDATA(NO)
CURRENT DATA YES	CURRENTDATA(YES)
DYNAMICRULES RUN	DYNAMICRULES(RUN)
DYNAMICRULES BIND	DYNAMICRULES(BIND)

<i>Table 172. Correspondence of function options to bind options (continued)</i>	
CREATE FUNCTION or ALTER FUNCTION option	bind command option
DYNAMICRULES DEFINEBIND	DYNAMICRULES(DEFINEBIND)
DYNAMICRULES DEFINERUN	DYNAMICRULES(DEFINERUN)
DYNAMICRULES INVOKEBIND	DYNAMICRULES(INVOKEBIND)
DYNAMICRULES INVOKERUN	DYNAMICRULES(INVOKERUN)
GET_ACCEL_ARCHIVE NO	GETACCELARCHIVE(NO)
GET_ACCEL_ARCHIVE YES	GETACCELARCHIVE(YES)
ISOLATION LEVEL CS	ISOLATION(CS)
ISOLATION LEVEL RS	ISOLATION(RS)
ISOLATION LEVEL RR	ISOLATION(RR)
ISOLATION LEVEL UR	ISOLATION(UR)
OPTHINT <i>string-constant</i>	OPTHINT(<i>hint-id</i>)
PACKAGE OWNER <i>authorization-name</i>	OWNER(<i>authorization-id</i>)
QUALIFIER <i>schema-name</i>	QUALIFIER(<i>qualifier-name</i>)
QUERY ACCELERATION NONE	QUERYACCELERATION(NONE)
QUERY ACCELERATION ENABLE	QUERYACCELERATION(ENABLE)
QUERY ACCELERATION ENABLE WITH FAILBACK	QUERYACCELERATION(ENABLE WITH FAILBACK)
QUERY ACCELERATION ELIGIBLE	QUERYACCELERATION(ELIGIBLE)
QUERY ACCELERATION ALL	QUERYACCELERATION(ALL)
REOPT ALWAYS	REOPT(ALWAYS)
REOPT NONE	REOPT(NONE)
REOPT ONCE	REOPT(ONCE)
ROUNDING DEC_ROUND_CEILING	ROUNDING(CEILING)
ROUNDING DEC_ROUND_DOWN	ROUNDING(DOWN)
ROUNDING DEC_ROUND_FLOOR	ROUNDING(FLOOR)
ROUNDING DEC_ROUND_HALF_DOWN	ROUNDING(HALFDOWN)
ROUNDING DEC_ROUND_HALF_EVEN	ROUNDING(HALFEVEN)
ROUNDING DEC_ROUND_HALF_UP	ROUNDING(HALFUP)
ROUNDING DEC_ROUND_UP	ROUNDING(UP)
SQL PATH <i>path-specification</i>	PATH(<i>path-specification</i>)
SYSTEM_TIME SENSITIVE NO	SYSTIMESENSITIVE(NO)
SYSTEM_TIME SENSITIVE YES	SYSTIMESENSITIVE(YES)
VALIDATE BIND	VALIDATE(BIND)
VALIDATE RUN	VALIDATE(RUN)

<i>Table 172. Correspondence of function options to bind options (continued)</i>	
CREATE FUNCTION or ALTER FUNCTION option	bind command option
WITH EXPLAIN	EXPLAIN(YES)
WITHOUT EXPLAIN	EXPLAIN(NO)
WITH IMMEDIATE WRITE	IMMEDWRITE(YES)
WITHOUT IMMEDIATE WRITE	IMMEDWRITE(NO)

Application compatibility level considerations for function objects

The application compatibility level controls the adoption and use of new capabilities and enhancements. When an object is created or altered, two separate application compatibility levels are used: one to process the definition of the object, and the other for processing the SQL statements in the object body:

Object definition	<p>The CURRENT APPLICATION COMPATIBILITY special register value is used to process the object definition, except for statements in the object body</p> <p>This application compatibility level is stored in the SYSENVIRONMENT.APPLCOMPAT column. You can use the environment ID value in the catalog definition of the object to locate the SYSENVIRONMENT row with the matching ENVID value.</p> <p>This application compatibility level can be changed when the object is regenerated.</p>
Statements in the object body	<p>The application compatibility level that is implicitly or explicitly specified with the APPLCOMPAT option of the CREATE or ALTER statement is used to process statements in the object body.</p> <p>This application compatibility level is stored in the SYSPACKAGE.APPLCOMPAT column for the package associated with the object definition.</p>

Altering a function definition using a lower application compatibility level than the current definition

If the CURRENT APPLICATION COMPATIBILITY special register value is lower than the application compatibility level of the existing object definition, altering an object might result in an error even if the content of the ALTER statement is valid at the current level. The errors can occur when the existing object definition contains some functionality that requires a higher level than the CURRENT APPLICATION COMPATIBILITY special register setting.

Application compatibility levels for regenerating function objects

For ALTER statements that regenerate objects, the object definition is reprocessed using the application compatibility setting that is specified implicitly or explicitly by the USING APPLICATION COMPATIBILITY clause that follows the REGENERATE keyword. This application compatibility value replaces the existing value in the SYSENVIRONMENT.APPLCOMPAT column for the environment settings associated with the object definition.

If the USING APPLICATION COMPATIBILITY clause is not specified, the existing application compatibility value in the SYSENVIRONMENT.APPLCOMPAT column for the object definition is used to reprocess the text associated with the object definition.

The behavior of the statements in the body remains controlled by the value the existing APPLCOMPAT option of the object.

Invalidation of packages

This statement might invalidate all packages that depend on target objects, and sometimes other related objects through cascading effects, depending on the clauses and keywords specified and

other factors. When a version of an SQL function is altered to change certain options that are specified for the active version, all application packages that refer to that function are marked invalid, and those invoking packages require a rebind. This includes changes to certain bind options and routine options that result in the implicit regeneration of the function. These options are marked accordingly in the following table in columns "Change requires rebind of invoking application" and "Change results in implicit regeneration of the entire body of the function." For more information, see [Changes that invalidate packages \(Db2 Application programming and SQL\)](#).

Implicit rebind and regeneration

When certain attributes of an SQL function are changed, the body of the function might be rebound or regenerated. The columns "Change results in implicit rebind of non-control statements in the body of the function" and the "Change results in implicit regeneration of the entire body of the function" in the following table summarize when implicit rebind and regeneration occurs when specific options are changed.

CREATE FUNCTION or ALTER FUNCTION option	Change requires rebind of invoking application?	Change results in implicit rebind of non-control statements in the body of the function?	Change results in implicit regeneration of the entire body of the function?
ACCELERATION WAITFOR DATA	No	Yes	No
ACCELERATOR	No	Yes	No
ALLOW DEBUG MODE, DISALLOW DEBUG MODE, or DISABLE DEBUG MODE	Yes "1" on page 1139, "2" on page 1139	Yes "1" on page 1139	Yes
APPLICATION ENCODING SCHEME	Yes	Yes	Yes
ARCHIVE SENSITIVE	Yes	Yes	Yes
ASUTIME	Yes	No	No
BUSINESS_TIME SENSITIVE	Yes	Yes	Yes
CURRENT DATA	No	Yes	No
DATE FORMAT	Yes	Yes	Yes
DECIMAL	Yes	Yes	Yes
DYNAMICRULES	No	Yes	No
FOR UPDATE CLAUSE OPTIONAL or FOR UPDATE CLAUSE REQUIRED	Yes	Yes	Yes
GET_ACCEL_ARCHIVE	Yes	Yes	Yes
INHERIT SPECIAL REGISTERS or DEFAULT SPECIAL REGISTERS	Yes	No	No
ISOLATION LEVEL	No	Yes	No

Table 173. CREATE FUNCTION and ALTER FUNCTION options that result in rebind or regeneration of the function when changed (continued)

CREATE FUNCTION or ALTER FUNCTION option	Change requires rebind of invoking application?	Change results in implicit rebind of non-control statements in the body of the function?	Change results in implicit regeneration of the entire body of the function?
MODIFIES SQL DATA, READS SQL DATA, or CONTAINS SQL	Yes	Yes	Yes
NOT DETERMINISTIC or DETERMINISTIC	No	No	No
OPTHINT	No	Yes	No
PACKAGE OWNER	No	Yes	No
QUALIFIER	No	Yes	No
QUERY ACCELERATION	Yes	Yes	Yes
REOPT	No	Yes	No
ROUNDING	Yes	Yes	Yes
SQL PATH	No	Yes	No
SYSTEM_TIME SENSITIVE	Yes	Yes	Yes
TIME FORMAT	Yes	Yes	Yes
VALIDATE RUN or VALIDATE BIND	No	Yes	No
WITH EXPLAIN or WITHOUT EXPLAIN	No	Yes	No
WITH IMMEDIATE WRITE or WITHOUT IMMEDIATE WRITE	No	Yes	No
WLM ENVIRONMENT FOR DEBUG MODE	Yes	No	No
<p>Note:</p> <ol style="list-style-type: none"> 1. The function package is rebound or regenerated if a value of ALLOW DEBUG MODE is changed to DISALLOW DEBUG MODE 2. Invoking applications are invalidated if a value of DISALLOW DEBUG MODE is changed to DISABLE DEBUG MODE 			

Considerations for SQL processor programs:

SQL processor programs (such as SPUFI, the command line processor, and DSNTEP2) might not correctly parse SQL statements in the routine body that are ended with semicolons. These processor programs accept multiple SQL statements as input when each statement is separated with a terminator character. Processor programs that use a semicolon as the SQL statement terminator might truncate an ALTER FUNCTION statement with embedded semicolons and pass only a portion of the statement to Db2. Therefore, you might need to change to SQL terminator character for these processor programs.

Considerations for the SYSENVIRONMENTS catalog table:

An ALTER statement that specifies new environment settings will result in a new row being added to the SYSENVIRONMENTS catalog table. The new row will be added even if an error is subsequently encountered during processing of the statement. Thus, a new SYSENVIRONMENT row might be added to the table even for an ALTER statement that fails.

Dependent objects:

An SQL routine is dependent on objects that are referenced in the routine body.

Altering a function from NOT SECURED to SECURED:

Typically, the security administrator will examine the data that is accessed by a function, ensure that it is secure, and grant the CREATE_SECURE_OBJECT privilege to the user that requires privileges to change the user-defined function to be secured. After the function is changed to SECURED, the security administrator will revoke the CREATE_SECURE_OBJECT privilege from the owner of the function.

The function is considered secure after the ALTER FUNCTION statement is executed. Db2 treats the SECURED attribute as an assertion that declares that the security administrator has established an audit procedure for all changes to the user-defined function. Db2 assumes that such a control audit procedure is in place for all subsequent ALTER FUNCTION statements or changes to external packages.

Packages and statements in the dynamic statement cache that reference the function are invalidated.

Altering a function from SECURED to NOT SECURED:

Packages and statements in the dynamic statement cache that reference the function are invalidated when the function is changed from SECURED to NOT SECURED. An function that is not secured might negatively impact performance if that function accesses data in a table that is using row access control or column access control. To minimize the performance impact, either change the function to use the SECURED option or deactivate row access control or column access control for the table that the function is accessing.

Invoking other user-defined functions in a secure function:

When a secure user-defined function is referenced in an SQL data change statement that references a table that is using row access control or column access control, and if the secure user-defined function invokes other user-defined functions, the nested user-defined functions are not validated as secure. If those nested functions can access sensitive data, the security administrator needs to ensure that those functions are allowed to access sensitive data and should ensure that a change control audit procedure has been established for all changes to those functions.

The SECURE column in the DSN_FUNCTION_TABLE EXPLAIN table:

The SECURE column in the DSN_FUNCTION_TABLE EXPLAIN table indicates if a user-defined function is considered secure.

Altering obfuscated functions:

Obfuscated functions cannot be altered in any way.

Deploying a compiled SQL function:

When a BIND DEPLOY command is issued to deploy a compiled SQL function to a target location, the SECURED and NOT SECURED options are included in the deployment process.

When deploying a compiled SQL function, if a function with the same target name does not exist at the target location, the deployed function is created as a new function at the target location with the same SECURED or NOT SECURED option that is specified (or the default of NOT SECURED is used) in the source function of the deployment.

When deploying a compiled SQL function, if a function with the same target name already exists at the target location, the deployed function is either added as a new version of the function or is used to replace an existing version of the function. The SECURED or NOT SECURED option of the deployed function must be the same as that of the existing function at the target location

Compatibilities:

For compatibility with the CREATE FUNCTION (SQL scalar) statement, the following clause can be specified, but will be ignored:

- LANGUAGE SQL

Optional syntax:

To provide compatibility with the syntax of the CREATE FUNCTION statement, the following options can also be specified:

- SPECIFIC
- PARAMETER CCSID

However, if these options are specified, the value for the option must be the same as the value that is already in effect for the function.

Alternative syntax and synonyms:

To provide compatibility with previous releases of Db2 or other products in the Db2 family, Db2 supports the following keywords:

- VARIANT as a synonym for NOT DETERMINISTIC
- NOT VARIANT as a synonym for DETERMINISTIC
- NULL CALL as a synonym for CALLED ON NULL INPUT
- NOT NULL CALL as a synonym for RETURNS NULL ON NULL INPUT
- TIMEZONE can be specified as an alternative to TIME ZONE

Examples for ALTER FUNCTION (compiled SQL scalar)

Example 1

Modify the definition for an SQL function to indicate that the function is deterministic.

```
ALTER FUNCTION MY_UDF1
  DETERMINISTIC;
```

Example 2

The following statement changes the existing function options for the active version of the REVERSE SQL function. If you need to change a different version of the function, you would specify *VERSION routine-version-id* in place of ACTIVE VERSION. Note, the ALTER clause that precedes the version specification can be omitted:

```
ALTER FUNCTION REVERSE
  ALTER ACTIVE VERSION
  NOT DETERMINISTIC
  ALLOW DEBUG MODE;
```

Example 3

To change the function body of any existing version of a function, you need to use the REPLACE clause. The following statement changes both the function body and the existing SQL data access option for the version V2 of the REVERSE function. The list of parameters is specified even though no changes are made to the list. To replace an existing version of the function, you must specify the list of parameters, RETURNS clause, any options that are to have non-default values (even if those options are already specified in the version of the function that you are replacing), and the body of the function, as in the following statement:

```
ALTER FUNCTION REVERSE(INSTR VARCHAR(4000))
  REPLACE VERSION V2 (INSTR VARCHAR(4000))
  RETURNS VARCHAR(4000)
  DETERMINISTIC
  NO EXTERNAL ACTION
  CONTAINS SQL
  BEGIN
    DECLARE REVSTR, RESTSTR VARCHAR(4000) DEFAULT '';
    DECLARE LEN INT;
    IF INSTR IS NULL THEN
      RETURN NULL;
    END IF;
    SET RESTSTR = INSTR;
    SET LEN = LENGTH(INSTR);
```

```

WHILE LEN > 0 DO
    SET (REVSTR, RESTSTR, LEN) = (SUBSTR(RESTSTR, 1, 1) CONCAT
        REVSTR, SUBSTR(RESTSTR, 2, LEN - 1), LEN - 1);
END WHILE;
RETURN REVSTR;
END

```

Example 4

To add a new version of an existing function, use the ADD VERSION clause. The following statement adds a new version of the REVERSE function to combine two SET statements into one SET statement. The list of parameters is specified even though the new version of the function uses the same parameters as the existing version of the function. To add a new version of the function, you must specify the list of parameters, RETURNS clause, any options that will have non-default values, and the body of the function, as in the following statement, which creates version V3 of the REVERSE function:

```

ALTER FUNCTION REVERSE(INSTR VARCHAR(4000))
ADD VERSION V3 (INSTR VARCHAR(4000))
RETURNS VARCHAR(4000)
DETERMINISTIC
NO EXTERNAL ACTION
CONTAINS SQL
BEGIN
    DECLARE REVSTR, RESTSTR VARCHAR(4000) DEFAULT '';
    DECLARE LEN INT;
    IF INSTR IS NULL THEN
        RETURN NULL;
    END IF;
    SET (RESRSTR, LEN) = (INSTR, LENGTH(INSTR));
    WHILE LEN > 0 DO
        SET (REVSTR, RESTSTR, LEN) = (SUBSTR(RESTSTR, 1, 1) CONCAT
            REVSTR, SUBSTR(RESTSTR, 2, LEN - 1), LEN - 1);
    END WHILE;
    RETURN REVSTR;
END

```

Example 5

To change the currently active version of the function, you must specify the ACTIVATE VERSION clause on the ALTER FUNCTION statement, even if the version you want to be the active version has just been defined. The following statement causes version V3 of the REVERSE SQL function to be the currently active version:

```

ALTER FUNCTION REVERSE(INSTR VARCHAR(4000))
ACTIVATE VERSION V3;

```

Example 6

To regenerate the currently active version of the function, you must specify the REGENERATE clause, as in the following statement:

```

ALTER FUNCTION REVERSE(INSTR VARCHAR(4000))
REGENERATE ACTIVE VERSION;

```

ALTER FUNCTION statement (inlined SQL scalar function)

The ALTER FUNCTION (inlined SQL scalar) statement changes the description of a user-defined inlined SQL scalar function at the current server.

Invocation for ALTER FUNCTION (inlined SQL scalar)

This statement can be embedded in an application program or issued interactively. It is an executable statement that can be dynamically prepared only if DYNAMICRULES RUN behavior is in effect. For more information, see [“Authorization IDs and dynamic SQL”](#) on page 94.

Authorization for ALTER FUNCTION (inlined SQL scalar)

The privilege set defined below must include at least one of the following:

- Ownership of the function

- The ALTERIN privilege on the schema
- SYSADM authority
- SYSCTRL authority
- System DBADM
- Installation SYSOPR authority (when the current SQLID of the process is set to SYSINSTL)

The authorization ID that matches the schema name implicitly has the ALTERIN privilege on the schema.

If the authorization ID that is used to alter the function has the installation SYSADM authority or the installation SYSOPR authority and if the current SQLID is set to SYSINSTL, the function is identified as system-defined function when the function definition is reevaluated.

Additional privileges might be required in the following situations:

- If *SQL-routine-body* is specified, the privilege set must include the privileges that are required to execute the statements in *SQL-routine-body*.
- If a user-defined type is referenced (for example, as the data type of a parameter), the privilege set must include at least one of the following:
 - Ownership of the user-defined type
 - The USAGE privilege on the user-defined type
 - SYSADM authority

At least one of the following privileges is required if the SECURED option is specified or if the function is currently secured and the NOT SECURED option is specified:

- SECADM authority
- CREATE_SECURE_OBJECT privilege

Privilege set: If the statement is embedded in an application program, the privilege set is the privileges that are held by the owner of the package.

If the statement is dynamically prepared, the privilege set is the set of privileges that are held by the SQL authorization IDs of the process. The specified routine name can include a schema name (a qualifier). However, if the schema name is not the same as one of these SQL authorization IDs, one of the following conditions must be met:

1. The privilege set includes SYSADM authority
2. The privilege set includes SYSCTRL authority
3. The SQL authorization ID of the process has the ALTERIN privilege on the schema

Syntax for ALTER FUNCTION (inlined SQL scalar)

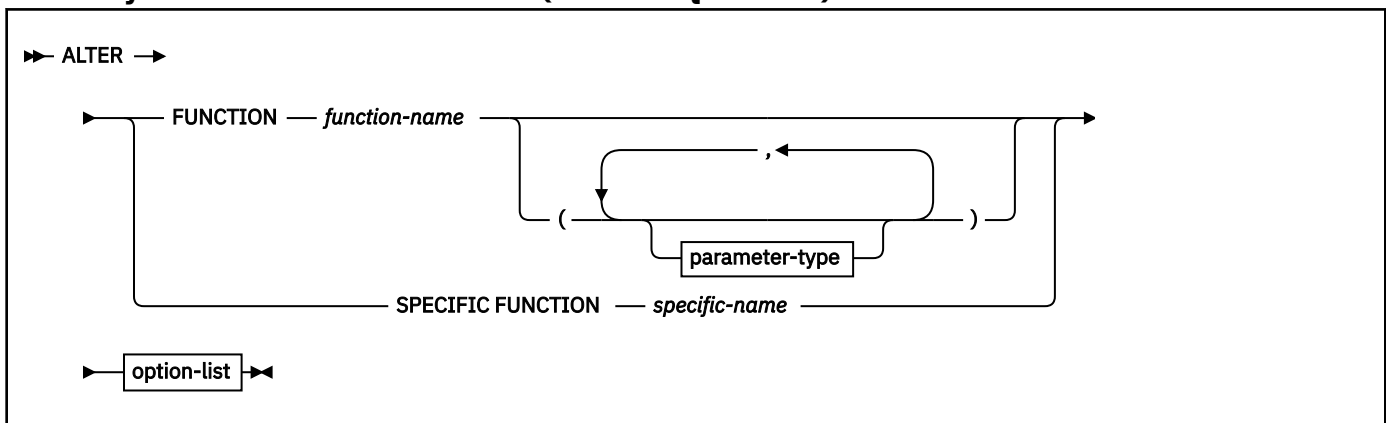

parameter-type:

» data-type «

data-type:

» built-in-type «
distinct-type-name

built-in-type:

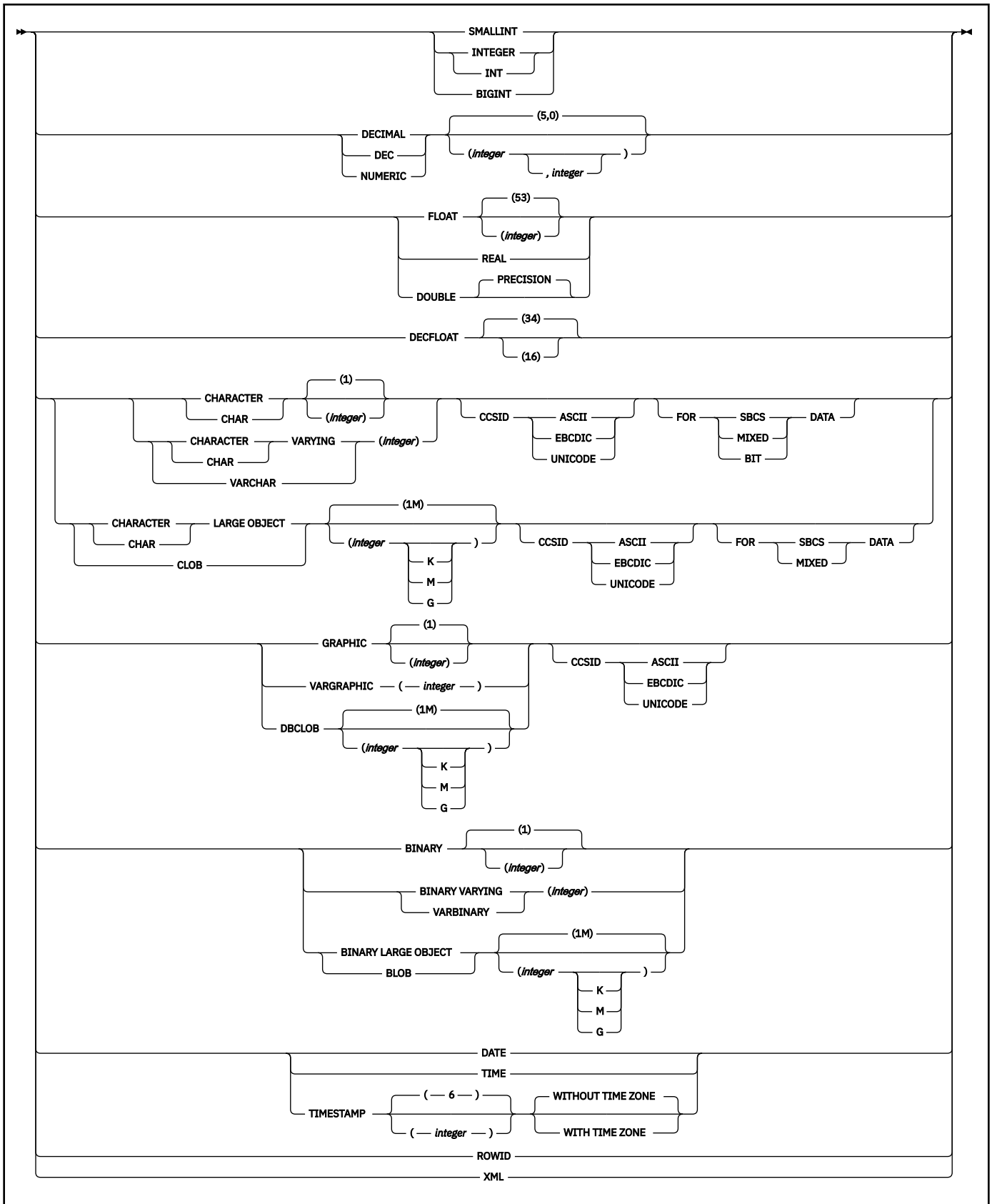

option-list: (Specify options in any order. Specify at least one option. Do not specify the same option more than one time.)

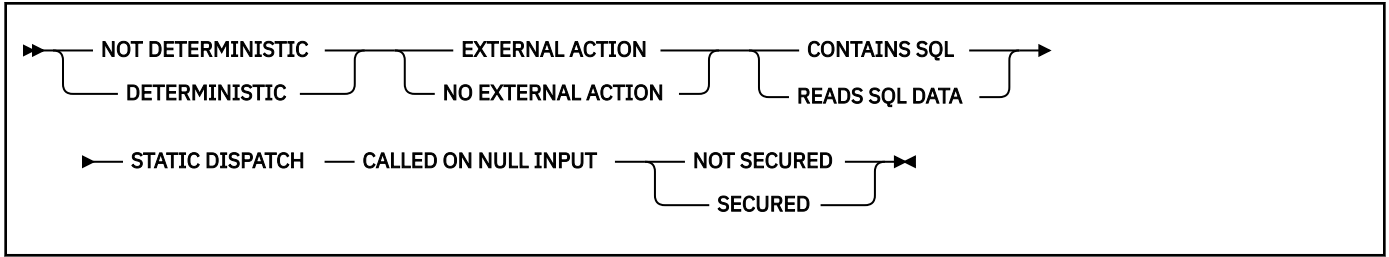

Description for ALTER FUNCTION (inlined SQL scalar)

One of the following three clauses identifies the function to be changed.

FUNCTION *function-name*

Identifies the SQL function by its function name.

The identified function must be an inlined SQL scalar function. There must be exactly one function with *function-name* in the schema. The function can have any number of input parameters.²⁵ If the schema does not contain a function with *function-name* or contains more than one function with this name, an error occurs.

The function must not be obfuscated.

FUNCTION *function-name (parameter-type,...)*

Identifies the SQL function by its function signature, which uniquely identifies the function.

function-name

Gives the function name of the inlined SQL scalar function.

If *function-name()* is specified, the function that is identified must have zero parameters.

(parameter-type,...)

Specifies the number of input parameters of the function and the name and data type of each parameter.

(data-type,...)

Identifies the number of input parameters of the function and the data type of each parameter. The data type of each parameter must match the data type that was specified in the CREATE FUNCTION statement for the parameter in the corresponding position. The number of data types and the logical concatenation of the data types are used to uniquely identify the function. Therefore, you cannot change the number of parameters or the data types of the parameters.

For data types that have a length, precision, or scale attribute, you can use a set of empty parentheses, specify a value, or accept the default values:

- Empty parentheses indicate that Db2 is to ignore the attribute when determining whether the data types match.

For example, DEC() will be considered a match for a parameter of a function defined with a data type of DEC(7,2). Similarly DECFLOAT() will be considered a match for DECFLOAT(16) or DECFLOAT(34).

FLOAT cannot be specified with empty parentheses because its parameter value indicates different data types (REAL or DOUBLE).

- If you use a specific value for a length, precision, or scale attribute, the value must exactly match the value that was specified (implicitly or explicitly) in the CREATE FUNCTION statement.

The specific value for FLOAT(*n*) does not have to exactly match the defined value of the source function because $1 \leq n \leq 21$ indicates REAL and $22 \leq n \leq 53$ indicates DOUBLE. Matching is based on whether the data type is REAL or DOUBLE.

²⁵ If the function has more than 30 parameters, only the first 30 parameters are used to determine whether the function is unique.

- If length, precision, or scale is not explicitly specified and empty parentheses are not specified, the default length of the data type is implied. The implicit length must exactly match the value that was specified (implicitly or explicitly) in the CREATE FUNCTION statement.

For data types with a subtype or encoding scheme attribute, specifying the FOR *subtype* DATA clause or the CCSID clause is optional. Omission of either clause indicates that Db2 is to ignore the attribute when determining whether the data types match. If you specify either clause, it must match the value that was implicitly or explicitly specified in the CREATE FUNCTION statement.

See “CREATE FUNCTION statement (overview)” on page 1424 for more information on the specification of the parameter list.

A function with the function signature must exist in the explicitly or implicitly specified schema.

SPECIFIC FUNCTION *specific-name*

Identifies a particular user-defined function by its specific name. The name is implicitly or explicitly qualified with a schema name. An inlined SQL scalar function with the specific name must exist in the schema. If the specific name is not qualified, it is implicitly qualified with a schema name as described in the description for FUNCTION *function-name*.

NOT DETERMINISTIC or DETERMINISTIC

Specifies whether the function returns the same results each time that the function is invoked with the same input arguments.

NOT DETERMINISTIC

The function might not return the same result each time that the function is invoked with the same input arguments. The function depends on some state values that affect the results. Db2 uses this information to disable the merging of views and table expressions when processing SELECT or SQL data change statements that refer to this function. An example of a function that is not deterministic is one that generates random numbers.

NOT DETERMINISTIC must be specified explicitly or implicitly if the function program accesses a special register or invokes another function that is not deterministic.

DETERMINISTIC

The function always returns the same result each time that the function is invoked with the same input arguments. An example of a deterministic function is a function that calculates the square root of the input. Db2 uses this information to enable the merging of views and table expressions for SELECT or SQL data change statements that refer to this function. If applicable, specify DETERMINISTIC to prevent non-optimal access paths from being chosen for SQL statements that refer to this function.

EXTERNAL ACTION or NO EXTERNAL ACTION

Specifies whether the function takes an action that changes the state of an object that Db2 does not manage. An example of an external action is sending a message or writing a record to a file.

EXTERNAL ACTION

The function can take an action that changes the state of an object that Db2 does not manage.

Some SQL statements that invoke functions with external actions can result in incorrect results if parallel tasks execute the function. For example, if the function sends a note for each initial call to it, one note is sent for each parallel task instead of once for the function.

If you specify EXTERNAL ACTION, Db2:

- Materializes the views and table expressions in SELECT or SQL data change statements that refer to the function. This materialization can adversely affect the access paths that are chosen for the SQL statements that refer to this function. Do not specify EXTERNAL ACTION if the function does not have an external action.
- Does not move the function from one task control block (TCB) to another between FETCH operations.
- Does not allow another function or stored procedure to use the TCB until the cursor is closed. This is also applicable for cursors declared WITH HOLD.

The only changes to resources made outside of Db2 that are under the control of commit and rollback operations are those changes made under RRS control.

EXTERNAL ACTION must be specified implicitly or explicitly specified if the SQL routine body invokes a function that is defined with EXTERNAL ACTION.

NO EXTERNAL ACTION

The function does not take any action that changes the state of an object that Db2 does not manage. Db2 uses this information to enable the merging of views and table expressions for SELECT or SQL data change statements that refer to this function. If applicable, specify NO EXTERNAL ACTION to prevent non-optimal access paths from being chosen for SQL statements that refer to this function.

Db2 does not verify that the function program is consistent with the specification of EXTERNAL ACTION or NO EXTERNAL ACTION.

READS SQL DATA or CONTAINS SQL

Specifies the classification of SQL statements and nested routines that this routine can execute or invoke. The database manager verifies that the SQL statements issued by the function, and all routines locally invoked by the routine, are consistent with this specification; the verification is not performed when nested remote routines are invoked. For the classification of each statement, see [Appendix D, “SQL statement data access classification for routines,”](#) on page 2275.

READS SQL DATA

Specifies that the function can execute statements with a data access classification of READS SQL DATA, CONTAINS SQL, or NO SQL. The function cannot execute SQL statements that modify data.

READS SQL DATA is the default.

CONTAINS SQL

Specifies that the function can execute only SQL statements with a data access classification of CONTAINS SQL or NO SQL. The function cannot execute SQL statements the read or modify data.

STATIC DISPATCH

At function resolution time, Db2 chooses a function based on the static (or declared) types of the function parameters.

CALLED ON NULL INPUT

The function is called regardless of whether any of the input arguments are null, making the function responsible for testing for null arguments. The function can return null.

SECURED or NOT SECURED

Specifies if the function is considered secure.

SECURED

Specifies that the function is considered secure.

Use of this clause or keyword might invalidate packages that depend on the target object, or packages that depend on related objects through cascading effects. See [Changes that invalidate packages \(Db2 Application programming and SQL\)](#).

NOT SECURED

Specifies that the function is considered not secure. NOT SECURED must not be specified when a row permission or a column mask depends on the function.

When the function is invoked, the arguments of the function must not reference a column for which a column mask is enabled when the table is using active column access control.

Use of this clause or keyword might invalidate packages that depend on the target object, or packages that depend on related objects through cascading effects. See [Changes that invalidate packages \(Db2 Application programming and SQL\)](#).

Notes for ALTER FUNCTION (inlined SQL scalar)

ALTER FUNCTION for in use functions:

ALTER FUNCTION will be locked out from making changes if the function is in use. This wait for completion behavior happens even if the query invokes the function multiple times for processing multiple rows or if the query contains multiple references to the function that is being changed.

Invalidation of plans and packages:

When an inlined SQL function is altered, all the plans and packages that refer to that function are marked invalid.

Dependent objects:

An SQL routine is dependent on objects that are referenced in the routine body.

Altering a function from NOT SECURED to SECURED:

Typically, the security administrator will examine the data that is accessed by a function, ensure that it is secure, and grant the CREATE_SECURE_OBJECT privilege to the user that requires privileges to change the user-defined function to be secured. After the function is changed to SECURED, the security administrator will revoke the CREATE_SECURE_OBJECT privilege from the owner of the function.

The function is considered secure after the ALTER FUNCTION statement is executed. Db2 treats the SECURED attribute as an assertion that declares that the security administrator has established an audit procedure for all changes to the user-defined function. Db2 assumes that such a control audit procedure is in place for all subsequent ALTER FUNCTION statements or changes to external packages.

Packages and statements in the dynamic statement cache that reference the function are invalidated.

Altering a function from SECURED to NOT SECURED:

Packages and statements in the dynamic statement cache that reference the function are invalidated when the function is changed from SECURED to NOT SECURED. An function that is not secured might negatively impact performance if that function accesses data in a table that is using row access control or column access control. To minimize the performance impact, either change the function to use the SECURED option or deactivate row access control or column access control for the table that the function is accessing.

Invoking other user-defined functions in a secure function:

When a secure user-defined function is referenced in an SQL data change statement that references a table that is using row access control or column access control, and if the secure user-defined function invokes other user-defined functions, the nested user-defined functions are not validated as secure. If those nested functions can access sensitive data, the security administrator needs to ensure that those functions are allowed to access sensitive data and should ensure that a change control audit procedure has been established for all changes to those functions.

The SECURE column in the DSN_FUNCTION_TABLE EXPLAIN table:

The SECURE column in the DSN_FUNCTION_TABLE EXPLAIN table indicates if a user-defined function is considered secure.

Altering obfuscated functions:

Obfuscated functions cannot be altered in any way.

Compatibilities:

For compatibility with the CREATE FUNCTION (SQL scalar) statement, the following clause can be specified, but will be ignored:

- LANGUAGE SQL

Optional syntax:

To provide compatibility with the syntax of the CREATE FUNCTION statement, the following options can also be specified:

- SPECIFIC
- PARAMETER CCSID

However, if these options are specified, the value for the option must be the same as the value that is already in effect for the function.

Alternative syntax and synonyms:

To provide compatibility with previous releases of Db2 or other products in the Db2 family, Db2 supports the following keywords:

- VARIANT as a synonym for NOT DETERMINISTIC
- NOT VARIANT as a synonym for DETERMINISTIC
- NULL CALL as a synonym for CALLED ON NULL INPUT

Examples for ALTER FUNCTION (inlined SQL scalar)

Example 1: Modify the definition for an SQL function to indicate that the function is deterministic.

```
ALTER FUNCTION MY_UDF1
DETERMINISTIC;
```

ALTER FUNCTION statement (SQL table function)

The ALTER FUNCTION (SQL table) statement changes the description of a user-defined SQL table function at the current server.

Invocation for ALTER FUNCTION (SQL table)

This statement can be embedded in an application program or issued interactively. It is an executable statement that can be dynamically prepared only if DYNAMICRULES RUN behavior is in effect. For more information, see [“Authorization IDs and dynamic SQL” on page 94](#).

Authorization for ALTER FUNCTION (SQL table)

The privilege set that is defined below must include at least one of the following privileges or authorities:

- Ownership of the function
- The ALTERIN privilege on the schema
- SYSADM authority
- SYSCTRL authority
- System DBADM
- Installation SYSOPR authority (when the current SQLID of the process is set to SYSINSTL)

The authorization ID that matches the schema name implicitly has the ALTERIN privilege on the schema.

If the authorization ID that is used to alter the function has the installation SYSADM authority or the installation SYSOPR authority and if the current SQLID is set to SYSINSTL, the function is identified as system-defined function when the function definition is reevaluated.

If a distinct type is referenced (i.e. as the data type of an SQL variable in the body of the function), the privilege set must also include at least one of the following:

- Ownership of the distinct type
- The USAGE privilege on the distinct type
- SYSADM authority

At least one of the following privileges is required if the SECURED option is specified or if the function is currently secured and the NOT SECURED option is specified:

- SECADM authority
- CREATE_SECURE_OBJECT privilege

Privilege set: If the statement is embedded in an application program, the privilege set is the privileges that are held by the owner of the package.

If the statement is dynamically prepared, the privilege set is the set of privileges that are held by the SQL authorization IDs of the process. The specified routine name can include a schema name (a qualifier). However, if the schema name is not the same as one of these SQL authorization IDs, one of the following conditions must be met:

1. The privilege set includes SYSADM authority
2. The privilege set includes SYSCTRL authority
3. The SQL authorization ID of the process has the ALTERIN privilege on the schema

Syntax for ALTER FUNCTION (SQL table)

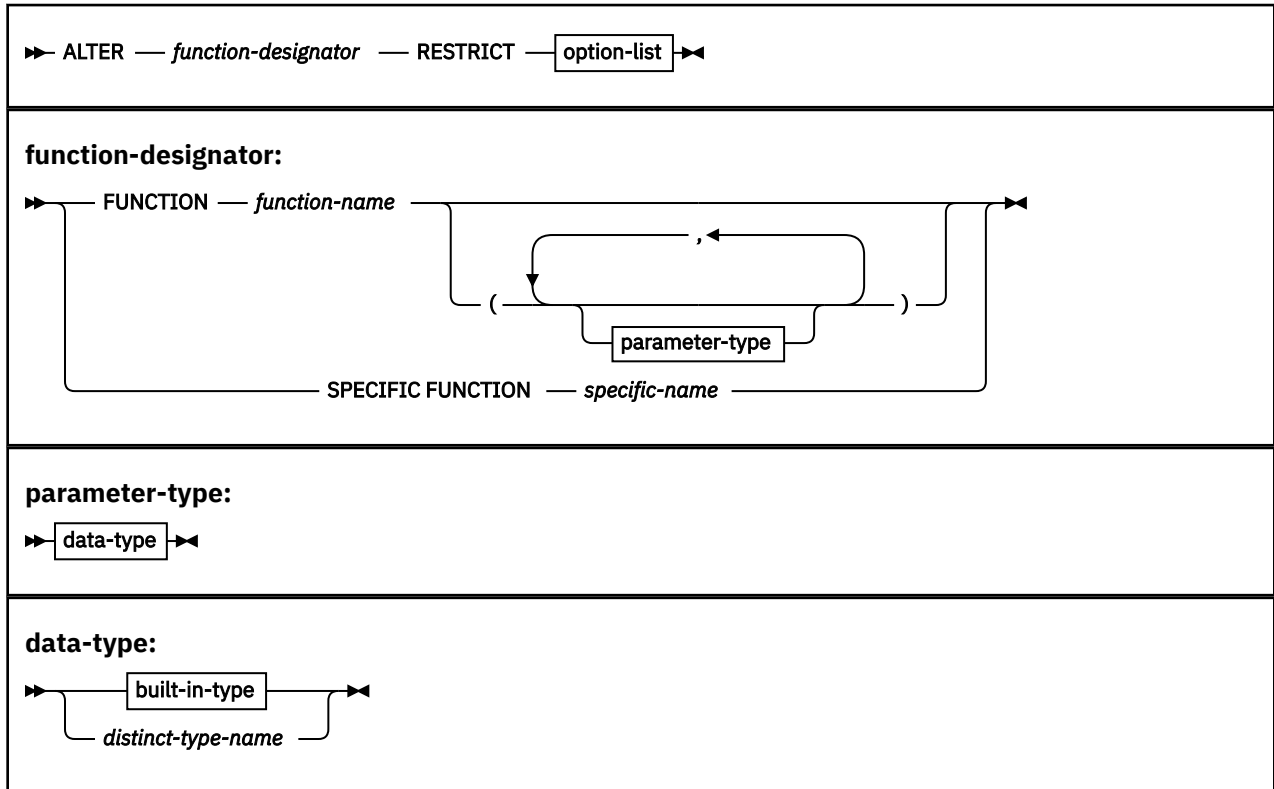

built-in-type:

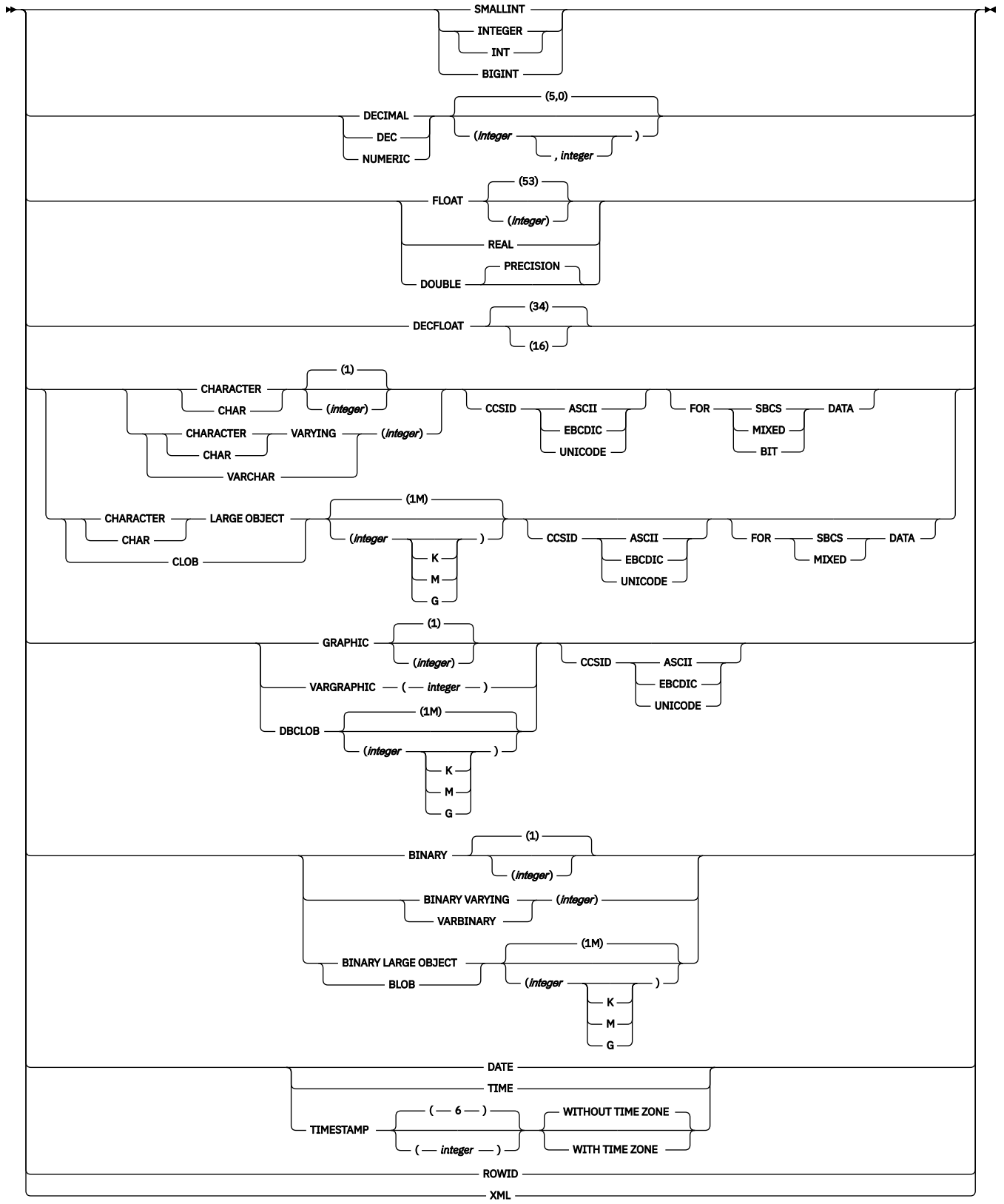

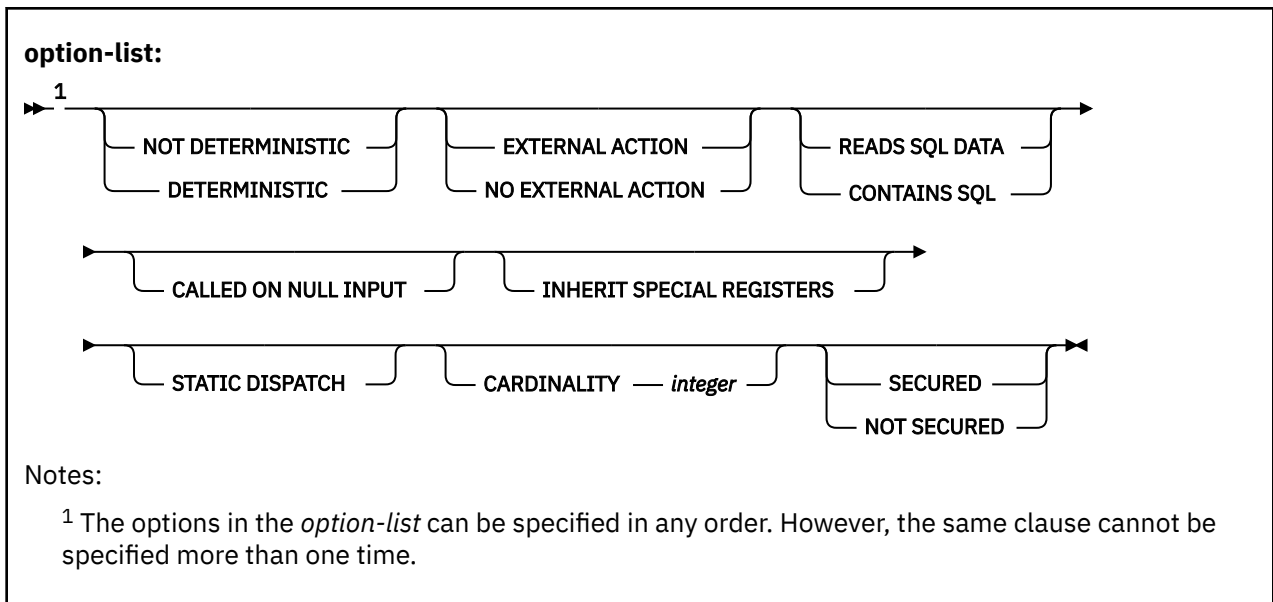

Description for ALTER FUNCTION (SQL table)

FUNCTION *function-name*

Identifies the SQL table function by its function name. The identified function must be an SQL table function.

There must be exactly one function with *function-name* in the schema. The function can have any number of input parameters. If the schema does not contain a function with *function-name*, or contains more than one function with this name, an error is returned.

The function must not be obfuscated.

FUNCTION *function-name (parameter-type, ...)*

Identifies the SQL function by its function signature, which uniquely identifies the function.

A function with the function signature must exist in the explicitly or implicitly specified schema.

function-name

Identifies the function name of the SQL function. If the function was defined with a table parameter (the LIKE TABLE *name* AS LOCATOR clause was specified in the CREATE FUNCTION statement to indicate that one of the input parameters is a transition table), the function signature cannot be used to uniquely identify the function. Instead, use one of the other syntax variations to identify the function with its function name, if unique, or its specified parameters.

If *function-name()* is specified, the function that is identified must have zero parameters.

parameter-type

Identifies the number of parameters of the function.

data-type

Identifies the data type of each input parameter of the function. The data type of each parameter must match the data type that was specified in the CREATE FUNCTION statement for the parameter in the corresponding position. The number of data types and the logical concatenation of the data types are used to uniquely identify the function. Therefore, you cannot change the number of parameters or the data types of the parameters.

For data types that have a length, precision, or scale attribute, you can use a set of empty parentheses, specify a value, or accept the default values:

- Empty parentheses indicate that Db2 is to ignore the attribute when determining whether the data types match.

For example, DEC() will be considered a match for a parameter of a function defined with a data type of DEC(7,2). Similarly DECFLOAT() will be considered a match for DECFLOAT(16) or DECFLOAT(34).

FLOAT cannot be specified with empty parentheses because its parameter value indicates different data types (REAL or DOUBLE).

- If you use a specific value for a length, precision, or scale attribute, the value must exactly match the value that was specified (implicitly or explicitly) in the CREATE FUNCTION statement.

The specific value for FLOAT(*n*) does not have to exactly match the defined value of the source function because $1 \leq n \leq 21$ indicates REAL and $22 \leq n \leq 53$ indicates DOUBLE. Matching is based on whether the data type is REAL or DOUBLE.

- If length, precision, or scale is not explicitly specified and empty parentheses are not specified, the default length of the data type is implied. The implicit length must exactly match the value that was specified (implicitly or explicitly) in the CREATE FUNCTION statement.

For data types with a subtype or encoding scheme attribute, specifying the FOR *subtype* DATA clause or the CCSID clause is optional. Omission of either clause indicates that Db2 is to ignore the attribute when determining whether the data types match. If you specify either clause, it must match the value that was implicitly or explicitly specified in the CREATE FUNCTION statement.

See [“CREATE FUNCTION statement \(overview\)” on page 1424](#) for more information on the specification of the parameter list.

RESTRICT

Indicates that the function will not be altered or replaced if it is referenced by any dependent package, function, materialized query table, or view.

Exception: When the ALTER statement specifies only DETERMINISTIC or NOT DETERMINISTIC, the function is altered, and all dependent packages are invalidated.

NOT DETERMINISTIC or DETERMINISTIC

Specifies whether the function returns the same results each time that the function is invoked with the same input arguments. Db2 does not verify that the function program is consistent with the specification of NOT DETERMINISTIC or DETERMINISTIC.

NOT DETERMINISTIC

Specifies that the function might not return the same result table each time that the function is invoked with the same input arguments, even when the referenced data in the database has not changed. The function depends on some state values that might affect the results. Db2 uses this information to disable the merging of views and table expressions when processing SELECT and SQL data change statements that refer to this function. An example of a table function that is not deterministic is one which references special registers, other functions that are not deterministic, or a sequence in a way that affects the table function's result table. Use of this clause or keyword might invalidate packages that depend on the target object, or packages that depend on related objects through cascading effects. See [Changes that invalidate packages \(Db2 Application programming and SQL\)](#).

DETERMINISTIC

Specifies that the function always returns the same result table each time that the function is invoked with the same input arguments (provided that the referenced data in the database has not changed). Db2 uses this information to enable the merging of views and table expressions for SELECT and SQL data change statements that refer to this function. Use of this clause or keyword might invalidate packages that depend on the target object, or packages that depend on related objects through cascading effects. See [Changes that invalidate packages \(Db2 Application programming and SQL\)](#).

If applicable, specify DETERMINISTIC to prevent non-optimal access paths from being chosen for SQL statements that refer to this function.

EXTERNAL ACTION or NO EXTERNAL ACTION

Specifies whether the function contains an external action. Db2 does not verify that the function program is consistent with the specification of EXTERNAL ACTION or NO EXTERNAL ACTION.

EXTERNAL ACTION

The function performs some external action (outside the scope of the function program). Thus, the function must be invoked with each successive function invocation. EXTERNAL ACTION must be specified if the function invokes another function that has external actions.

NO EXTERNAL ACTION

The function does not perform any external action. It need not be called with each successive function invocation. Functions that are defined with NO EXTERNAL ACTION might perform better than functions that are defined with EXTERNAL ACTION because the function might not be invoked for each successive function invocation.

READS SQL DATA or CONTAINS SQL

Specifies the classification of SQL statements and nested routines that this routine can execute or invoke. The database manager verifies that the SQL statements issued by the function, and all routines locally invoked by the routine, are consistent with this specification; the verification is not performed when nested remote routines are invoked. For the classification of each statement, see [Appendix D, “SQL statement data access classification for routines,” on page 2275](#).

READS SQL DATA

Specifies that the function can execute statements with a data access indication of READS SQL DATA or CONTAINS SQL. The function cannot execute SQL statements that modify data.

CONTAINS SQL

Specifies that the function can execute only SQL statements with a data access indication of CONTAINS SQL. The function cannot execute statements that read or modify data.

CALLED ON NULL INPUT

Specifies that the function is called regardless of whether any of the input argument values are null, making the function responsible for testing for null argument values. The function might return an empty table, depending on the logic in the body of the function.

INHERIT SPECIAL REGISTERS

Specifies that existing values of special registers are inherited upon entry to the function.

STATIC DISPATCH

Specifies that at function resolution time, Db2 chooses a function based on the static (or declared) types of the function parameters.

CARDINALITY *integer*

Specifies an estimate of the expected number of rows that the function returns. The number is used for optimization purposes. The value of *integer* must be in the range 0–2147483647.

If a function has an infinite cardinality (the function never returns the end-of-table condition and always returns a row), a query that requires the end-of-table condition to work correctly will need to be interrupted.

SECURED or NOT SECURED

Specifies whether the function is considered secure.

SECURED

Specifies that the function is considered secure.

Use of this clause or keyword might invalidate packages that depend on the target object, or packages that depend on related objects through cascading effects. See [Changes that invalidate packages \(Db2 Application programming and SQL\)](#).

NOT SECURED

Specifies that the function is considered not secure. NOT SECURED must not be specified when a row permission or a column mask depends on the function.

When the function is invoked, the arguments of the function must not reference a column for which a column mask is enabled when the table is using active column access control.

Use of this clause or keyword might invalidate packages that depend on the target object, or packages that depend on related objects through cascading effects. See [Changes that invalidate packages \(Db2 Application programming and SQL\)](#).

Notes for ALTER FUNCTION (SQL table)

Invalidation of packages:

This statement might invalidate all packages that depend on target objects, and sometimes other related objects through cascading effects, depending on the clauses and keywords specified and other factors. For more information, see [Changes that invalidate packages \(Db2 Application programming and SQL\)](#).

Dependent objects:

An SQL routine is dependent on objects that are referenced in the routine body.

Altering a function from NOT SECURED to SECURED:

Typically, the security administrator will examine the data that is accessed by a function, ensure that it is secure, and grant the CREATE_SECURE_OBJECT privilege to the user that requires privileges to change the user-defined function to be secured. After the function is changed to SECURED, the security administrator will revoke the CREATE_SECURE_OBJECT privilege from the owner of the function.

The function is considered secure after the ALTER FUNCTION statement is executed. Db2 treats the SECURED attribute as an assertion that declares that the security administrator has established an audit procedure for all changes to the user-defined function. Db2 assumes that such a control audit procedure is in place for all subsequent ALTER FUNCTION statements or changes to external packages.

Packages and statements in the dynamic statement cache that reference the function are invalidated.

Altering a function from SECURED to NOT SECURED:

Packages and statements in the dynamic statement cache that reference the function are invalidated when the function is changed from SECURED to NOT SECURED. An function that is not secured might negatively impact performance if that function accesses data in a table that is using row access control or column access control. To minimize the performance impact, either change the function to use the SECURED option or deactivate row access control or column access control for the table that the function is accessing.

Invoking other user-defined functions in a secure function:

When a secure user-defined function is referenced in an SQL data change statement that references a table that is using row access control or column access control, and if the secure user-defined function invokes other user-defined functions, the nested user-defined functions are not validated as secure. If those nested functions can access sensitive data, the security administrator needs to ensure that those functions are allowed to access sensitive data and should ensure that a change control audit procedure has been established for all changes to those functions.

The SECURE column in the DSN_FUNCTION_TABLE EXPLAIN table:

The SECURE column in the DSN_FUNCTION_TABLE EXPLAIN table indicates if a user-defined function is considered secure.

Altering obfuscated functions:

Obfuscated functions cannot be altered in any way.

Compatibilities:

For compatibility with the CREATE FUNCTION (SQL table) statement, the following clause can be specified, but will be ignored:

- LANGUAGE SQL

Alternative syntax and synonyms:

To provide compatibility with previously releases of Db2 or other products in the Db2 family, Db2 supports the following keywords:

- VARIANT as a synonym for NOT DETERMINISTIC
- NOT VARIANT as a synonym for DETERMINISTIC
- NULL CALL as a synonym for CALLED ON NULL INPUT

Examples for ALTER FUNCTION (SQL table)

Example 1: The following statement modifies the definition of an SQL table function to set the estimated cardinality to 10,000.

```
ALTER FUNCTION GET_TABLE  
RESTRICT CARDINALITY 10000;
```

ALTER INDEX statement

The ALTER INDEX statement changes the description of an index at the current server.

Invocation for ALTER INDEX

This statement can be embedded in an application program or issued interactively. It is an executable statement that can be dynamically prepared only if DYNAMICRULES RUN behavior is in effect. For more information, see [“Authorization IDs and dynamic SQL”](#) on page 94.

Authorization for ALTER INDEX

The privilege set that is defined below must include one of the following:

- Ownership of the index
- Ownership of the table on which the index is defined
- DBADM authority for the database that contains the table
- SYSADM or SYSCTRL authority
- System DBADM
- Installation SYSOPR authority (when the current SQLID of the process is set to SYSINSTL)

If the database is implicitly created, the database privileges must be on the implicit database or on DSNDB04.

If BUFFERPOOL or USING STOGROUP is specified, additional privileges could be needed, as explained in the description of those clauses.

Privilege set: If the statement is embedded in an application program, the privilege set is the privileges that are held by the owner of the package. If the statement is dynamically prepared, the privilege set is the union of the privilege sets that are held by each authorization ID and role of the process.

Syntax for ALTER INDEX

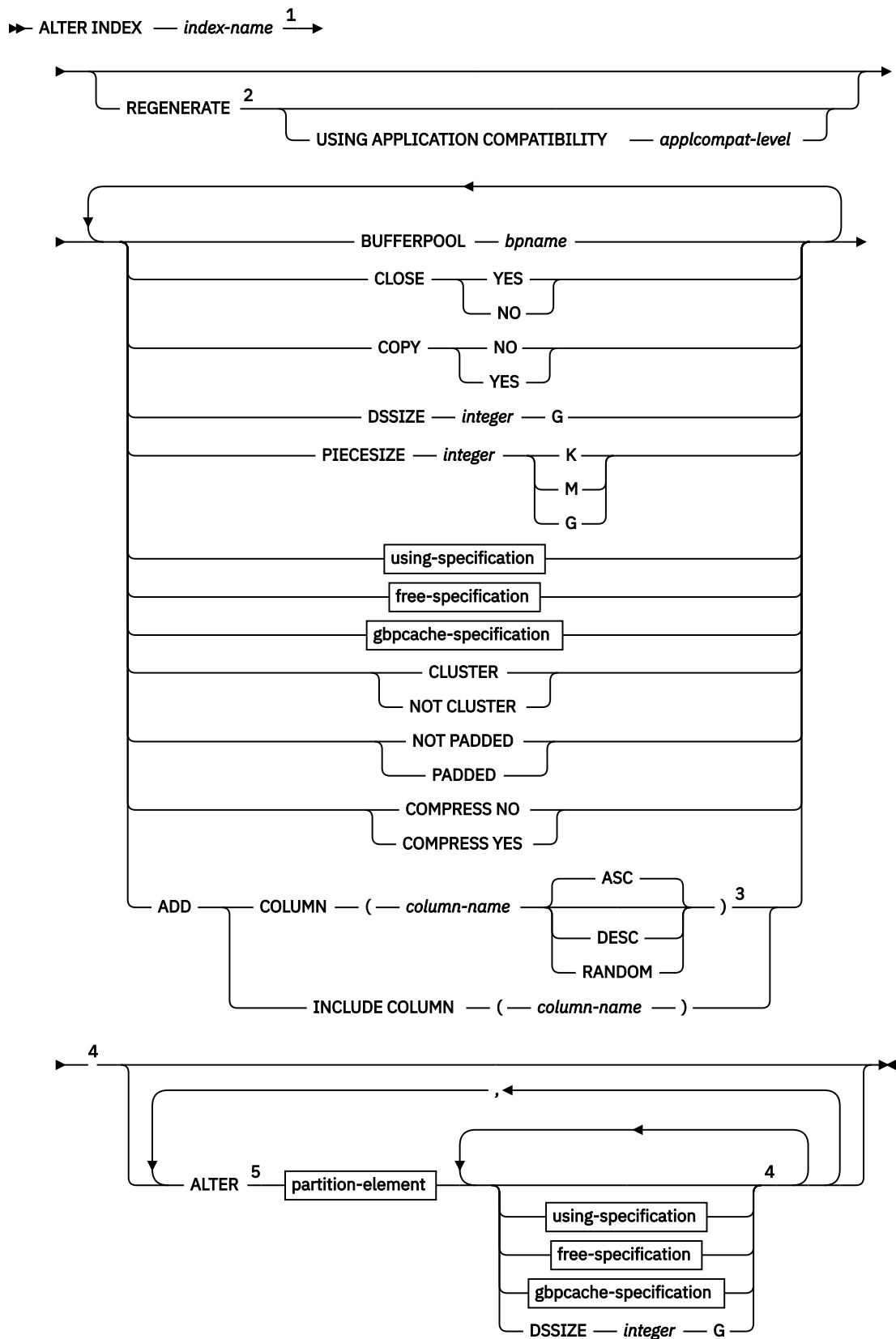

Notes:

¹ At least one clause must be specified after *index-name*. It can be from the optional list or it can be ALTER PARTITION.

- ² If REGENERATE is specified, it must be the only clause specified on the ALTER INDEX statement.
- ³ If ADD COLUMN and PADDED or NOT PADDED are specified, ADD COLUMN must be specified before PADDED or NOT PADDED.
- ⁴ The same clause must not be specified more than one time.
- ⁵ The ALTER clause can only be specified for partitioned indexes. The ALTER clause must be specified last.

using-specification:

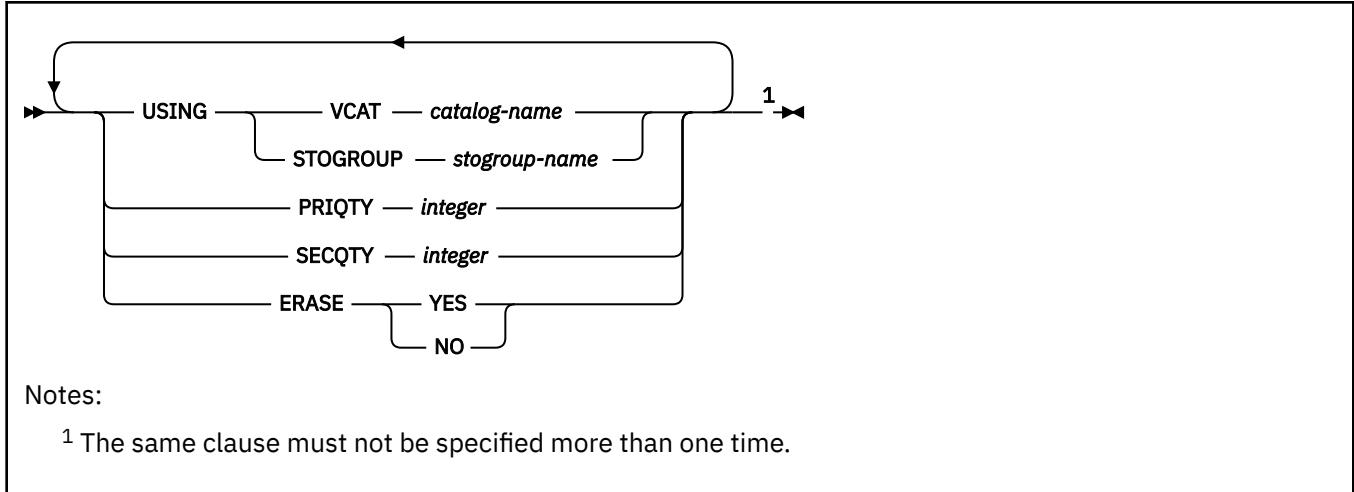

free-specification:

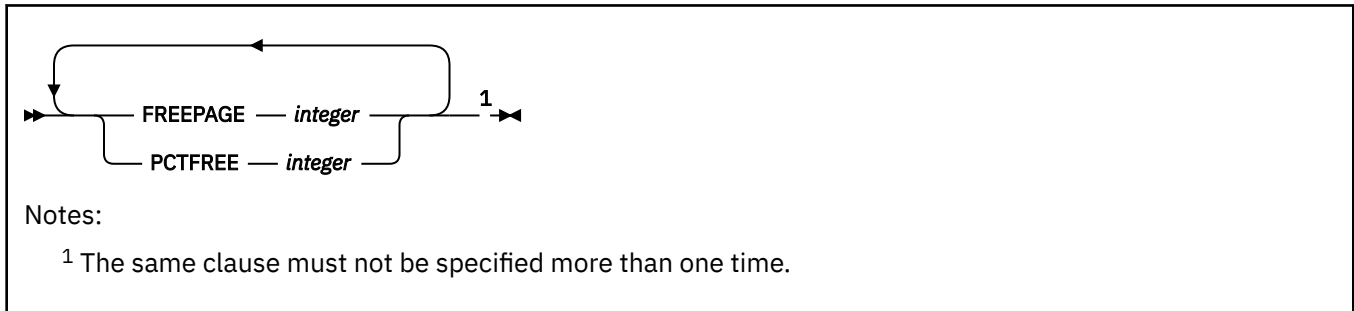

gbpcache-specification:



partition-element:

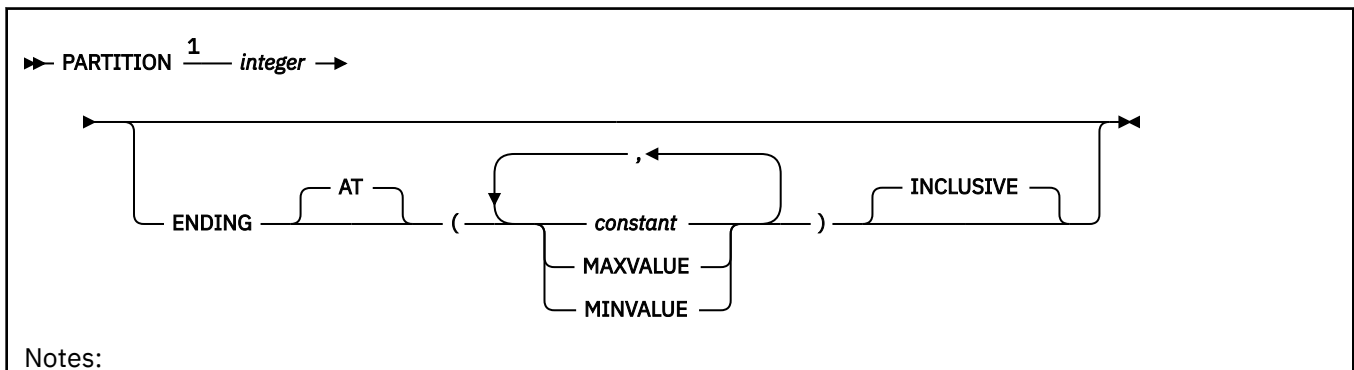

¹ If PARTITION is specified, either the ENDING clause, *using-specification*, *free-specification*, or *gbpcache-specification* should also be specified.

Description for ALTER INDEX

index-name

Identifies the index to be changed or regenerated. The name must identify a user-created index that exists at the current server. The name must not identify an index that is defined on a declared temporary table.

REGENERATE

Specifies that Db2 regenerates the structure that represents the index definition from the Db2 catalog.

Any existing authorities and dependencies are retained. The catalog is updated with the regenerated index definition. The index is put into rebuild-pending state and catalog entries for the index statistics are deleted. Use of this clause or keyword might invalidate packages that depend on the target object, or packages that depend on related objects through cascading effects. See [Changes that invalidate packages \(Db2 Application programming and SQL\)](#).

If the index cannot be successfully regenerated, an error is returned. In this case, the index must be dropped and re-created.

Generally, the REGENERATE keyword is used only for specific situations, such as when implicit regeneration fails for routines or objects, or Db2 maintenance requires objects or routines to be regenerated. For more information, see [When to regenerate Db2 database objects and routines \(Db2 Administration Guide\)](#).

USING APPLICATION COMPATIBILITY *applcompat-level*

Specifies that the object is regenerated under *applcompat-level* application compatibility rules. The ALTER statement fails if it includes any syntax, semantics, or options that require a higher application compatibility level.

If USING APPLICATION COMPATIBILITY is omitted, the regeneration uses the APPLCOMPAT value of the applicable SYSIBM.SYSENVIRONMENT catalog table row.

The following *applcompat-level* values can be specified:

VvvRrMmmm

Compatibility with the behavior of the identified Db2 function level. For example, V12R1M510 specifies compatibility with the highest available Db2 12 function level. The equivalent function level or higher must be activated.

For the new capabilities that become available in each application compatibility level, see:

- [SQL changes in Db2 13 application compatibility levels](#)
- [SQL changes in Db2 12 application compatibility levels](#)

Tip: Extra program preparation steps might be required to increase the application compatibility level for applications that use data server clients or drivers to access Db2 for z/OS. For more information, see [Setting application compatibility levels for data server clients and drivers \(Db2 Application programming and SQL\)](#).

V12R1

Compatibility with the behavior of Db2 12 function level 500. This value has the same result as specifying V12R1M500.

V11R1

Compatibility with the behavior of Db2 11 new-function mode. After migration to Db2 12, this value has the same result as specifying V12R1M100. For more information, see [V11R1 application compatibility level \(Db2 Application programming and SQL\)](#)

V10R1

Compatibility with the behavior of DB2 10 new-function mode. For more information, see [V10R1 application compatibility level \(Db2 Application programming and SQL\)](#).

BUFFERPOOL *bpname*

Identifies the buffer pool that is to be used for the index. *bpname* must identify an activated 4K, 8 KB, 16 KB, or 32 KB buffer pool, and the privilege set must include SYSADM authority, SYSCTRL authority, or the USE privilege for the buffer pool.

A buffer pool with a smaller size should be chosen for indexes with random insert patterns. A buffer pool with a larger size should be chosen for indexes with sequential insert patterns.

If the index is changed to use index compression (the COMPRESS YES clause), the buffer pool must be 8 KB, 16 KB, or 32 KB in size.

Depending on the situation when this clause is specified, Db2 might process the ALTER statement as a *pending data definition change*, which means the current object definition and data do not reflect the alteration at the time that the statement is issued. Instead, the altered object is placed in an advisory REORG-pending (AREOR) state, and a subsequent reorganization of the altered object with an appropriate utility materializes the changes to the catalog and data. For more information, see [Pending data definition changes \(Db2 Administration Guide\)](#).

If the change is an immediate change, the change to the description of the index takes effect the next time the data sets of the index space are opened. The data sets can be closed and reopened by a **STOP DATABASE** command to stop the index followed by a **START DATABASE** command to start the index.

If the buffer pool is changed to a buffer pool with a different page size, and the change is an immediate change, the index is placed into REBUILD-pending status.

CLOSE

Specifies whether the data set is eligible to be closed when the index is not being used and the limit on the number of open data sets is reached. The change to the close rule takes effect the next time the data sets of the index space are opened.

YES

Eligible for closing.

NO

Not eligible for closing.

If DSMAX is reached and there are no CLOSE YES page sets to close, CLOSE NO page sets will be closed.

COPY

Indicates whether the COPY utility is allowed for the index.

NO

Does not allow full image or concurrent copies or the use of the RECOVER utility on the index.

YES

Allows full image or concurrent copies and the use the RECOVER utility on the index. For data sharing, changing COPY to YES causes additional SCA (Shared Communications Area) storage to be used until the next full or incremental image copy is taken or until COPY is set back to NO.

DSSIZE *integer G*

Specifies the maximum size for each partition of a partitioned index. Any integer 1–1024 can be specified (for example, 1 G or 1024 G). DSSIZE can be specified only if the index uses relative page numbering. This keyword is not valid for nonpartitioned secondary indexes.

The DSSIZE value that is specified at the index level is applied to each of the partitions of the index.

If the data sets of the index are already created, you cannot specify a partition-level DSSIZE value that is smaller than the current DSSIZE value of the specified partition, or an index-level DSSIZE value that is smaller than the current DSSIZE value for any partition.

The value of DSSIZE for a particular partition is given by the first of these choices that applies:

- The value of DSSIZE given in the PARTITION clause for that partition.
- The value given by a DSSIZE keyword that is not in any PARTITION clause.
- The default value is inherited from the base table space.

PIECESIZE integer

Specifies the maximum addressability of each data set for a non-partitioned index. The PIECESIZE clause can only be specified for non-partitioned indexes.

Be aware that when you alter the PIECESIZE value, the index is placed into page set REBUILD-pending (PSRBD) status. The entire index space becomes inaccessible. You must run the REBUILD INDEX or the REORG TABLESPACE utility to remove that status.

The subsequent keyword K, M, or G, indicates the units of the value that is specified in *integer*. *integer* can be separated from K, M, or G by 0 or more spaces.

K

Indicates that the *integer* value is to be multiplied by 1024 to specify the maximum data set size in bytes. *integer* must be a power of two in the range 1–268435456.

M

Indicates that the *integer* value is to be multiplied by 1048576 to specify the maximum data set size in bytes. *integer* must be a power of two in the range 1–262144.

G

Indicates that the *integer* value is to be multiplied by 1073741824 to specify the maximum data set size in bytes. *integer* must be a power of two in the range 1–256.

The following table shows the valid values for the data set size, which depend on the size of the table space.

Table 174. Valid values of PIECESIZE clause

K units	M units	G units	Size attribute of table space
256K			
512 K			
1024 K	1 M		
2048 K	2 M		
4096 K	4 M		
8192 K	8 M		
16384 K	16 M		
32768 K	32 M		
65536 K	64 M		
131072 K	128 M		
262144 K	256 M		
524288 K	512 M		
1048576 K	1024 M	1 G	
2097152 K	2048 M	2 G	
4194304 K	4096 M	4 G	LARGE, DSSIZE 4 G (or greater)
8388608 K	8192 M	8 G	DSSIZE 8 G (or greater)
16777216 K	16384 M	16 G	DSSIZE 16 G (or greater)
33554432 K	32768 M	32 G	DSSIZE 32 G (or greater)

Table 174. Valid values of *PIECESIZE* clause (continued)

K units	M units	G units	Size attribute of table space
67108864 K	65536 M	64 G	DSSIZE 64 G (or greater)
134217728 K	131072 M	128 G	DSSIZE 128 G (or greater)
268435456 K	262144 M	256 G	DSSIZE 256 G

The data set size limit for partitioned table spaces with more than 256 partitions is 4096.

begin using-specification block

The components of the *using-specification* are discussed below, first for non-partitioned indexes and then for partitioned indexes.

USING (specification for nonpartitioned indexes)

For nonpartitioned indexes, the USING clause specifies whether the data sets for the index are to be managed by the user or managed by Db2. The USING clause applies to every data set that can be used for the index.

If you specify USING, the index must be in the stopped state when the ALTER INDEX statement is executed. See [Altering storage attributes](#) to determine how and when changes take effect.

VCAT *catalog-name*

Specifies a user-managed data set.

The data sets are VSAM linear data sets cataloged in the integrated catalog facility catalog that *catalog-name* identifies. For more information about *catalog-name* values, see [“Naming conventions in SQL” on page 79](#).

More than one Db2 subsystem can share the integrated catalog facility catalogs with the current server. To avoid the chance of those subsystems attempting to assign the same name to different data sets, specify a *catalog-name* value that is not used by the other Db2 subsystems.

STOGROUP *stogroup-name*

Specifies using a Db2-managed data set that resides on a volume of the specified storage group. *stogroup-name* must identify a storage group that exists at the current server and the privilege set must include SYSADM authority, SYSCTRL authority, or the USE privilege for the storage group. When the new description of the index is applied, the description of the storage group must include at least one volume serial number. Each volume serial number must identify a volume that is accessible to z/OS for dynamic allocation of the data set, and all identified volumes must be of the same device type. Furthermore, the integrated catalog facility catalog used for the storage group must not contain an entry for the data set.

If you specify USING STOGROUP and the current data set is Db2-managed, omission of the PRIQTY, SECQTY, or ERASE clause is an implicit specification of the current value of the omitted clause.

If you specify USING STOGROUP to convert from user-managed data sets to Db2-managed data sets:

- Omission of the PRIQTY clause is an implicit specification of the default value. For information on how Db2 determines the default value, see [Rules for primary and secondary space allocation](#).
- Omission of the SECQTY clause is an implicit specification of the default value. For information on how Db2 determines the default value, see [Rules for primary and secondary space allocation](#).
- Omission of the ERASE clause is an implicit specification of ERASE NO.

PRIQTY *integer*

Specifies the minimum primary space allocation for a Db2-managed data set. *integer* must be a positive integer, or -1. This clause can be specified only if the data set is currently managed by Db2 and USING VCAT is not specified.

When you specify `PRIQTY` with a positive integer value, the primary space allocation is at least n kilobytes, where n is:

12

If *integer* is less than 12

integer

If *integer* is in the range 12–4194304

2097152

If both of the following conditions are true:

- *integer* is greater than 2097152.
- The index is a non-partitioned index on a table space that is not defined with the `LARGE` or `DSSIZE` attribute.

4194304

If *integer* is greater than 4194304

If you specify `PRIQTY` with a value of -1, Db2 uses a default value for the primary space allocation. For information on how Db2 determines the default value for primary space allocation, see [Rules for primary and secondary space allocation](#).

If `USING STOGROUP` is specified and `PRIQTY` is omitted, the value of `PRIQTY` is its current value. (However, if the current data set is being changed from being user-managed to Db2-managed, the value is its default value. See the description of `USING STOGROUP`.)

If you specify `PRIQTY` and do not specify a value of -1, Db2 specifies the primary space allocation to access method services using the smallest multiple of 4 KB not less than n , where n is defined as in the `PRIQTY` description. The allocated space can be greater than the amount of space requested by Db2. For example, it could be the smallest number of tracks that will accommodate the space requested. To more closely estimate the actual amount of storage, see [DEFINE CLUSTER command \(DFSMS Access Method Services for Catalogs\)](#).

When determining a suitable value for `PRIQTY`, be aware that two of the pages of the primary space could be used by Db2 for purposes other than storing index entries.

SECQTY *integer*

Specifies the minimum secondary space allocation for a Db2-managed data set. *integer* must be a positive integer, 0, or -1. This clause can be specified only if the data set is currently managed by Db2 and `USING VCAT` is not specified.

If you specify `SECQTY` with a value of -1, Db2 uses a default value for the secondary space allocation.

If `USING STOGROUP` is specified and `SECQTY` is omitted, the value of `SECQTY` is its current value. (However, if the current data set is being changed from being user-managed to Db2-managed, the value is its default value. See the description of `USING STOGROUP`.)

For information on the actual value that is used for secondary space allocation, whether you specify a value or Db2 uses a default value, see [Rules for primary and secondary space allocation](#).

If you specify `SECQTY`, and do not specify a value of -1, Db2 specifies the secondary space allocation to access method services using the smallest multiple of 4 KB not less than *integer*. The allocated space can be greater than the amount of space requested by Db2. For example, it could be the smallest number of tracks that will accommodate the space requested. To more closely estimate the actual amount of storage, see [DEFINE CLUSTER command \(DFSMS Access Method Services for Catalogs\)](#).

ERASE

Indicates whether the Db2-managed data sets are to be erased when they are deleted during the execution of a utility or an SQL statement that drops the index.

NO

Does not erase the data sets. Operations involving data set deletion will perform better than `ERASE YES`. However, the data is still accessible, though not through Db2.

YES

Erases the data sets. As a security measure, Db2 overwrites all data in the data sets with zeros before they are deleted.

This clause can be specified only if the data set is currently managed by Db2 and USING VCAT is not specified. If you specify ERASE, the index must be in the stopped state when the ALTER INDEX statement is executed. See [Altering storage attributes](#) to determine how and when changes take effect.

USING (specification for partitioned indexes:)

For a partitioned index, there is an optional PARTITION clause for each partition. A *using-specification* can be specified at the global level or at the partition level. A *using-specification* within a PARTITION clause applies only to that partition. A *using-specification* specified before any PARTITION clauses applies to every partition except those with a PARTITION clause with a *using-specification*.

For Db2-managed data sets, the values of PRIQTY, SECQTY, and ERASE for each partition are given by the first of these choices that applies:

- The values of PRIQTY, SECQTY, and ERASE given in the *using-specification* within the PARTITION clause for the partition. Do not use more than one *using-specification* in any PARTITION clause.
- The values of PRIQTY, SECQTY, and ERASE given in the *using-specification* before any PARTITION clause
- The current values of PRIQTY, SECQTY, and ERASE

For data sets that are being changed from user-managed to Db2-managed, the values of PRIQTY, SECQTY, and ERASE for each partition are given by the first of these choices that applies:

- The values of PRIQTY, SECQTY, and ERASE given in the *using-specification* within the PARTITION clause for the partition. Do not use more than one *using-specification* in any PARTITION clause.
- The values of PRIQTY, SECQTY, and ERASE given in a *using-specification* before any PARTITION clauses
- The default values of PRIQTY, SECQTY, and ERASE, which are:
 - PRIQTY 12
 - SECQTY 12, if PRIQTY is not specified in either *using-specification*, or 10% of PRIQTY or 3 times the index page size (whichever is larger) when PRIQTY is specified
 - ERASE NO

Any partition for which USING or ERASE is specified (either explicitly at the partition level or implicitly at the global level) must be in the stopped state when the ALTER INDEX statement is executed. See [Altering storage attributes](#) to determine how and when changes take effect.

VCAT *catalog-name*

Specifies a user-managed data set with a name that starts with the specified catalog name. You must specify the catalog name in the form of an SQL identifier. Thus, you must specify an alias if the name of the integrated catalog facility catalog is longer than eight characters.

If *n* is the number of the partition, the identified integrated catalog facility catalog must already contain an entry for the *v*th data set of the index, conforming to the Db2 naming convention for data sets described in [“Naming conventions in SQL”](#) on page 79.

One or more Db2 subsystems could share integrated catalog facility catalogs with the current server. To avoid the chance of having one of those subsystems attempt to assign the same name to different data sets, select a value for *catalog-name* that is not used by the other Db2 subsystems.

Db2 assumes one and only one data set for each partition.

STOGROUP *stogroup-name*

If USING STOGROUP is used, *stogroup-name* must identify a storage group that exists at the current server and the privilege set must include SYSADM authority, SYSCTRL authority, or the USE privilege for the storage group.

Db2 assumes one and only one data set for each partition.

For information on the PRIQTY, SECQTY, and ERASE clauses, see the description of those clauses in the *using-specification* for secondary indexes.

end using-specification block

begin free-specification block

FREEPAGE *integer*

Specifies how often to leave a page of free space when index entries are created as the result of executing a Db2 utility. One free page is left for every *integer* pages. The value of *integer* can range from 0 to 255. The change to the description of the index or partition has no effect until it is loaded or reorganized using a Db2 utility. Do not specify FREEPAGE for an implicitly created XML index.

PCTFREE *integer*

Determines the percentage of free space to leave in each nonleaf page and leaf page when entries are added to the index or partition as the result of executing a Db2 utility. The first entry in a page is loaded without restriction. When additional entries are placed in a nonleaf or leaf page, the percentage of free space is at least as great as *integer*.

The value of *integer* can range 0–99, however, if a value greater than 10 is specified, only 10 percent of free space will be left in nonleaf pages. The change to the description of the index or partition has no effect until it is loaded or reorganized using a Db2 utility. Do not specify PCTFREE for an implicitly created XML index.

If the index is partitioned, the values of FREEPAGE and PCTFREE for a particular partition are given by the first of these choices that applies:

- The values of FREEPAGE and PCTFREE given in the PARTITION clause for that partition. Do not use more than one *free-specification* in any PARTITION clause.
- The values given in a *free-specification* before any PARTITION clauses.
- The current values of FREEPAGE and PCTFREE for that partition.

end free-specification block

begin gbpcache-specification block

GBPCACHE

Specifies what index pages are written to the group buffer pool in a data sharing environment. In a non-data-sharing environment, you can specify this option, but it is ignored.

CHANGED

When there is inter-Db2 read-write interest on the index or partition, updated pages are written to the group buffer pool. When there is no inter-Db2 read-write interest, the group buffer pool is not used. Inter-Db2 read-write interest exists when more than one member in the data sharing group has the index or partition open, and at least one member has it open for update.

If the index is in a group buffer pool that is defined as GBPCACHE(NO), CHANGED is ignored and no pages are cached to the group buffer pool.

ALL

Indicates that pages are to be cached to the group buffer pool as they are read in from DASD, with one exception. When the page set is not GBP-dependent and one Db2 data sharing member has exclusive read-write interest in that page set (no other group members have any interest in the page set), no pages are cached in the group buffer pool.

If the index is in a group buffer pool that is defined as GBPCACHE(NO), ALL is ignored and no pages are cached to the group buffer pool.

NONE

Indicates that no pages are to be cached to the group buffer pool. Db2 uses the group buffer pool only for cross-invalidation.

If you specify NONE, the index or partition must not be in group buffer pool recover-pending (GRECP) status.

If the index is partitioned, the value of GBPCACHE for a particular partition is given by the first of these choices that applies:

1. The value of GBPCACHE given in the PARTITION clause for that partition. Do not use more than one *gbpcache-specification* in any PARTITION clause.
2. The value given in a *gbpcache-specification* before any PARTITION clauses.
3. The current value of GBPCACHE for that partition.

If you specify GBPCACHE in a data sharing environment, the index or partition must be in the stopped state when the ALTER INDEX statement is executed. You cannot alter the GBPCACHE value for certain indexes on Db2 catalog tables; for more information, see [“SQL statements allowed on the catalog” on page 2739](#).

end gbpcache-specification block

CLUSTER or NOT CLUSTER

Specifies whether the index is the clustering index for the table.

CLUSTER

The index is used as the clustering index for the table. This change takes effect immediately. Any subsequent insert operations will use the new clustering index. Existing data remains clustered by the previous clustering index until the table space is reorganized.

The implicit or explicit clustering index is ignored when data is inserted into a table space that is defined with MEMBER CLUSTER. Instead of using cluster order, Db2 chooses where to locate the data, based on available space. The MEMBER CLUSTER attribute affects only data that is inserted with an insert operation; data is always loaded and reorganized in cluster order.

Do not specify CLUSTER in the following cases:

- The index is for an auxiliary table.
- CLUSTER was used already for a different index on the table.
- The index is an XML index.
- The index includes expressions.
- The index is for a table that uses hash organization.
- The index is the hash overflow index for a table.

NOT CLUSTER

The index is not used as the clustering index of the table. If the index is already defined as the clustering index, it continues to be used as the clustering index by Db2 and the REORG utility until clustering is explicitly changed by specifying CLUSTER for a different index.

Specifying NOT CLUSTER for an index that is not a clustering index is ignored.

If the index is the partitioning index for a table that uses index-controlled partitioning, the table is converted to use table-controlled partitioning. The high limit key for the last partition is set to the highest possible value for ascending key columns or the lowest possible value for descending key columns. Use of this clause or keyword might invalidate packages that depend on the target object, or packages that depend on related objects through cascading effects. See [Changes that invalidate packages \(Db2 Application programming and SQL\)](#).

COMPRESS NO or COMPRESS YES

Specifies whether the index data will be compressed. If the index is partitioned, this option will apply to all partitions.

Depending on the situation when this clause is specified, Db2 might process the ALTER statement as a *pending data definition change*, which means the current object definition and data do not reflect the alteration at the time that the statement is issued. Instead, the altered object is placed in an advisory REORG-pending (AREOR) state, and a subsequent reorganization of the altered object with an appropriate utility materializes the changes to the catalog and data. For more information, see [Pending data definition changes \(Db2 Administration Guide\)](#).

If the change is an immediate change, the change to the description of the index takes effect the next time the data sets of the index space are opened. The data sets can be closed and reopened by a STOP DATABASE command to stop the index followed by a START DATABASE command to start the index.

If the compress attribute is changed to a different value, and the change is an immediate change, the index is placed into REBUILD-pending status.

COMPRESS NO

Specifies that index compression will be turned off.

COMPRESS YES

Specifies that the index will use index compression. COMPRESS YES can be specified for user-managed data sets only if the control interval size is 4K.

NOT PADDED or PADDED

Specifies how varying-length string columns are to be stored in the index. If the index contains no varying-length columns, this option is ignored, and a warning message is returned.

NOT PADDED

Specifies that varying-length string columns are not to be padded to their maximum length in the index. The length information for a varying-length column is stored with the key.

NOT PADDED is ignored and has no effect if the index is on an auxiliary table. Indexes on auxiliary tables are always padded.

When PADDED is changed to NOT PADDED, the maximum key length is recalculated with the varying-length formula $(2000 - n - 2m - 3d)$, where n is the number of columns that can contain null values, m is the number of varying-length columns, and d is the number of DECFLOAT columns in the key). If it is possible that the index key length might exceed the maximum length (because when it was padded, the formula $2000 - n$ was used), an error occurs.

PADDED

Specifies that varying-length string columns within the index are always padded with the default pad character to their maximum length.

When an index with at least one varying-length column is changed from PADDED to NOT PADDED, or vice versa, the index is placed in restricted rebuild-pending status (RBDP). The index cannot be accessed until it is rebuilt from the table (using the REBUILD INDEX, REORG TABLESPACE, or LOAD REPLACE utility). For nonpartitioned secondary indexes (NPSIs), the index is placed in page set rebuild-pending status (PSRBD), and the entire index must be rebuilt. In addition, dynamically cached statements that are dependent on the index are invalidated. Use of this clause or keyword might invalidate packages that depend on the target object, or packages that depend on related objects through cascading effects. See [Changes that invalidate packages \(Db2 Application programming and SQL\)](#).

Do not specify PADDED if the index is an XML index.

ADD COLUMN *column-name*

Adds *column-name* to the index.

column-name must be unqualified, must identify a column of the table, and must not be one of the existing columns of the index.

The column cannot be:

- a LOB column, or a distinct-type column that is based on a LOB data type
- A timestamp with time zone column or a column with a distinct-type that is based on the timestamp with time zone data type, if the PARTITION or PARTITION BY RANGE clause is also specified
- a VARBINARY column or a distinct-type column that is based on a VARBINARY data type, if the column is defined with the DESC attribute or if the index is defined with the PADDED attribute
- a row change timestamp column for a range partitioned index

A character or graphic string column that is added to an index must have the same encoding scheme as other character or graphic string columns in the index.

The index must not already be defined with the BUSINESS_TIME WITHOUT OVERLAPS specification.

A temporal referential constraint must not be dependent on the index.

The total number of columns for the index cannot exceed 64.

If a column is added to an index that is defined with the EXCLUDE NULL KEYS clause, the index is placed in REBUILD-pending status.

If the index is defined with the EXCLUDE NULL KEYS clause, the specified column must allow null values.

For PADDED indexes, the sum of the length attributes of the columns must not be greater than $2000 - n$, where n is the number of columns that can contain null values. For NOT PADDED indexes, the sum of the length attributes of the columns must not be greater than $2000 - n - 2m - 3d$, where n is the number of nullable columns, m is the number of varying-length columns, and d is the number of DECFLOAT columns.

The index cannot be any of the following types of indexes:

- A system-defined catalog index
- An index that enforces a primary key, unique key, or referential constraint
- An index that enforces a temporal referential constraint
- A partitioning index when index-controlled partitioning is being used
- A unique index required for a ROWID column defined as GENERATED BY DEFAULT
- An auxiliary index
- An XML index
- An index that includes expressions
- The hash overflow index for a table

The index is put into rebuild-pending (RBDP) status in the following cases:

- *column-name* specifies a ROWID column
- a column is added to a table, rows are inserted into the table, and the same column is added to an associated index all within the same commit scope
- a column is added to a table and then is added to an associated index in a separate commit scope

Otherwise, the index is put into an advisory reorg-pending (AREO*) state.

ASC

Index entries are put in ascending order by the column.

DESC

Index entries are put in descending order by the column.

RANDOM

Index entries are put in a random order by the column. RANDOM cannot be specified in the following cases:

- A varying length column is part of the index key and the index is defined with the NOT PADDED option.
- A column of the index key is defined as TIMESTAMP WITH TIME ZONE or DECFLOAT.
- The index is part of a partitioning key.

ADD INCLUDE (*column-name*)

Specifies an additional column to append to the set of index key columns of a unique index. Any column that is specified using INCLUDE *column-name*, is not used to enforce uniqueness. The included column might improve performance for some queries using index only access.

Columns that are specified in the ADD INCLUDE clause count towards the limits for the number of columns and the limits on the sum of the length attributes of the columns that are specified in the index. The total number of columns for the index cannot exceed 64.

column-name must be unqualified, must identify a column of the specified table, and must not be one of the existing columns of the index. *column-name* must not identify a LOB or DECFLOAT column (or a distinct type that is based on one of those types).

The INCLUDE clause cannot be specified for the following types of indexes:

- A system defined catalog index
- A non-unique index
- A partitioning index when index-controlled partitioning is used
- An auxiliary index
- An index on a foreign key
- An XML index
- An extended index
- An index that includes expressions
- An index that is created with the EXCLUDE NULL KEYS clause
- An index that is required for a temporal referential constraint

If a column is added to both a table and an associated index within the same commit scope and the column is not a ROWID column, the index is placed in an advisory reorg-pending state (AREO*). Otherwise, the index is placed in a rebuild-pending state (RBDP).

Columns in the INCLUDE list that are defined as character or graphic string data types must be defined with the same encoding scheme as other key columns with character or graphic string data types.

ALTER PARTITION *integer*

Identifies the partition of the index to be altered. For an index that has *n* partitions, you must specify an integer in the range 1 to *n*. You must not use this clause under the following conditions:

- If the index is nonpartitioned
- If the index is defined on a table that contains an XML column and uses index-controlled partitioning

You must use this clause if the index is partitioned and you specify the ENDING AT clause.

ENDING AT(*constant*), MAXVALUE, or MINVALUE

Specifies the highest value of the index key for the identified partition of the partitioning index. In this context, highest means highest in the sorting sequence of the index columns. In a column defined as ascending (ASC), highest and lowest have the usual meanings. In a column defined as descending (DESC), the lowest actual value is highest in the sorting sequence.

You must use at least one value (*constant*, MAXVALUE, or MINVALUE) after ENDING AT in each PARTITION clause. You can use as many values as there are columns in the key. The concatenation of all the values is the highest value of the key in the corresponding partition of the index. The length of each highest key value (also called the limit key) is the same as the length of the partitioning index

constant

Specifies a constant value with a data type that must conform to the rules for assigning that value to the column. If a string constant is longer or shorter than required by the length attribute of its column, the constant is either truncated or padded on the right to the required length. If the column is ascending, the padding character is X'FF'. If the column is descending, the padding character is X'00'. The precision and scale of a decimal constant must not be greater than the precision and scale of its corresponding column. A hexadecimal string constant (GX) cannot be specified.

MAXVALUE

Specifies a value greater than the maximum value for the limit key of a partition boundary (that is, all X'FF' regardless of whether the column is ascending or descending). If all of the columns in the partitioning key are ascending, a constant or the MINVALUE clause cannot be specified following MAXVALUE. After MAXVALUE is specified, all subsequent columns must be MAXVALUE.

MINVALUE

Specifies a value that is smaller than the minimum value for the limit key of a partition boundary (that is, all X'00' regardless of whether the column is ascending or descending). If all of the columns in the partitioning key are descending, a constant or the MAXVALUE clause cannot be specified following MAXVALUE. After MINVALUE is specified, all subsequent columns must be MINVALUE.

The key values are subject to the following rules:

- The first value corresponds to the first column of the key, the second value to the second column, and so on.
- If a key includes a ROWID column (or a column with a distinct type that is based on a ROWID data type), the values of the ROWID column are assumed to be in the range of X'000...00' to X'FFF...FF'. Only the first 17 bytes of the value that is specified for the corresponding ROWID column are considered.
- Using fewer values than there are columns in the key has the same effect as using the highest possible values for all omitted columns for an ascending index.
- If the key exceeds 255 bytes, only the first 255 bytes are considered.
- The highest value of the key in any partition must be lower than the highest value of the key in the next partition.
- The highest value of the key in the last partition depends on how the table space was defined. For table spaces created without the LARGE or DSSIZE option, the constants you specify after ENDING AT are not enforced. The highest value of the key that can be placed in the table is the highest possible value of the key.

For table spaces created with the LARGE or DSSIZE options, the constants you specify after ENDING AT are enforced. The value specified for the last partition is the highest value of the key that can be placed in the table. Any keys that are made invalid after the ALTER TABLE statement is executed are placed in a discard data set when you run the REORG utility. If the last partition is in reorg-pending status, regardless of whether you changed its limiting key values, you must specify a discard data set when you run the REORG utility.

ENDING AT must not be specified for any indexes defined on a table that uses table-controlled partitioning. Use ALTER TABLE ALTER PARTITION to modify the partitioning boundaries for a table that uses table-controlled partitioning.

INCLUSIVE

Specifies that the specified range values are included in the data partition.

Notes for ALTER INDEX**Pending definition changes:**

The following table lists clauses and specific conditions that cause an ALTER INDEX statement to be processed as a pending definition change, which is not reflected in the current definition or data at the time that the ALTER statement is issued. Instead, the index is placed in an advisory REORG-pending (AREOR) state. A subsequent reorganization of the entire index with an appropriate utility materializes the changes and applies the pending definition changes to the catalog and data.

If there are no pending definition changes for the table space, you can run the REORG INDEX utility with SHRLEVEL CHANGE or the REORG TABLESPACE utility with SHRLEVEL CHANGE or REFERENCE to materialize the changes to the definition of the index. If pending definition changes also exist for the

table space, you must run the REORG TABLESPACE utility with SHRLEVEL CHANGE or REFERENCE to enable the changes to the definition of the index (and the pending table space definition).

Clause or option	Pending definition change used if...
BUFFERPOOL	<p>The data sets of the index are created, and all of the following conditions are true:</p> <ul style="list-style-type: none"> • The index is defined on a base table, or an associated XML table or auxiliary table, where the table space for the base table is a universal table space (UTS) or is being converted to a UTS by a pending definition change. • The buffer pool is changed to a buffer pool with a different size, or the buffer pool is changed to a buffer pool with the same size and the table space or objects in the table space have pending definition changes.
COMPRESS	<p>The data sets of the index are created, and all of the following conditions are true:</p> <ul style="list-style-type: none"> • The index is defined on a base table, or an associated XML table or auxiliary table, where the table space for the base table is a universal table space (UTS) or is being converted to a UTS by a pending definition change. • The compress attribute is changed, or the table space or objects in the table space have pending definition changes.

For more information, see [Pending data definition changes \(Db2 Administration Guide\)](#).

Restrictions for pending data definition changes

The following restrictions apply to ALTER TABLESPACE, ALTER TABLE, and ALTER INDEX statements that result in pending data definition changes:

- Options that cause pending changes cannot be specified with options that take effect immediately.
- Options that cause pending changes cannot be specified for the Db2 catalog, other system objects, or objects in a work file database.
- The DROP PENDING CHANGES clause of the ALTER TABLESPACE statement cannot be specified for a catalog table space.
- If the table space, or any table it contains is in an incomplete state, you cannot specify options that cause pending changes.
- For ALTER INDEX, options that cause pending changes cannot be specified if the definition of the table space or table on which the index is defined is not complete.

Also, many alter operations are restricted for a table space that has existing pending data definition changes for the table space, the table it contains, or indexes on the table. For more information, see [Restrictions for pending data definition changes \(Db2 Administration Guide\)](#).

Altering storage attributes:

The USING, PRIQTY, SECQTY, and ERASE clauses define the storage attributes of the index or partition. If you specify the USING or ERASE clause when altering storage attributes, the index or partition must be in the stopped state when the ALTER INDEX statement is executed. A **STOP DATABASE...SPACENAM...** command can be used to stop the index or partition.

If the catalog name changes, the changes take effect after you move the data and start the index or partition using the **START DATABASE...SPACENAM...** command. The catalog name can be implicitly or explicitly changed by the ALTER INDEX statement. The catalog name also changes when you move the data to a different device. See the procedures for moving data in [Moving a Db2 data set \(Db2 Administration Guide\)](#).

Changes to the secondary space allocation (SECQTY) take effect the next time Db2 extends the data set; however, the new value is not reflected in the integrated catalog until you use the REORG,

RECOVER, or LOAD REPLACE utility on the index or partition. Changes to the other storage attributes take effect the next time you use the REORG, RECOVER, or LOAD REPLACE utility on the index or partition. If you change the primary space allocation parameters or erase rule, you can have the changes take effect earlier if you move the data before you start the index or partition.

Altering indexes on Db2 catalog tables:

For details on altering options on catalog tables, see [“SQL statements allowed on the catalog” on page 2739](#).

Size restriction for the object descriptor of an index:

The following case might result in an error being returned if the ALTER INDEX statement results in a versioned object descriptor that is larger than 30,000 bytes being added (or updated):

- An ALTER INDEX statement that results in the first version of the object descriptor being generated for the index

You might need to drop and re-create the index if the object descriptor for the index exceeds 30,000 bytes.

Invalidation of packages:

This statement might invalidate all packages that depend on target objects, and sometimes other related objects through cascading effects, depending on the clauses and keywords specified and other factors. For more information, see [Changes that invalidate packages \(Db2 Application programming and SQL\)](#).

Altering limit keys:

If you specify ALTER PARTITION *integer* ENDING AT to change the limit key values of a partitioning index, the packages that are dependent on that index are marked invalid and go through automatic rebind the next time they are run.

Restrictions on SQL data change statements in the same commit scope as ALTER INDEX:

SQL data change statements that affect an index cannot be performed in the same commit scope as ALTER INDEX statements that affect that index.

Altering indexes for tables that are involved in a clone relationship:

You cannot change any index for a table that is involved in a clone relationship (base table or clone table). If a change to an index is required, the clone table must be dropped before the index can be changed. After the index is changed, the clone table can be created again.

Adding a varying length column to a key for a system with NOT PADDED as the default:

If the system default is NOT PADDED (the value of field PAD INDEXES BY DEFAULT on installation panel DSNTIPE is NO), no varying length columns are in the key, and the PADDED or NOT PADDED option is not explicitly specified when the index is created, the PADDED column of the SYSIBM.SYSINDEXES catalog table is populated with a blank value. If a varying length column is later added to the key, the value of the PADDED column in SYSIBM.SYSINDEXES is changed to 'Y' to indicate that the index is now a PADDED index.

Running utilities:

You cannot execute the ALTER INDEX statement while a Db2 utility has control of the index or its associated table space.

Alternative syntax and synonyms:

To provide compatibility with previous releases of Db2 or other products in the Db2 family, Db2 supports the following keywords when altering the partitions of a partitioned index:

- PART can be specified as a synonym for PARTITION. In addition, the ALTER keyword that precedes PARTITION is optional. In addition, if you alter more than one partition, specifying a comma between each ALTER PARTITION *integer* clause is optional.
- VALUES can be specified as a synonym for ENDING AT.

Although these keywords are supported as alternatives, they are not the preferred syntax.

Examples for ALTER INDEX

Example 1

Alter the index DSN8C10.XEMP1. Indicate that Db2 is not to close the data sets that support the index when there are no current users of the index.

```
ALTER INDEX DSN8C10.XEMP1
CLOSE NO;
```

Example 2

Alter the index DSN8C10.XPROJ1. Use BP1 as the buffer pool that is to be associated with the index, indicate that full image or concurrent copies on the index are allowed, and change the maximum size of each data set to 8 megabytes.

```
ALTER INDEX DSN8C10.XPROJ1
BUFFERPOOL BP1
COPY YES
PIECESIZE 8 M;
```

Example 3

Assume that index X1 contains a least one varying-length column and is a padded index. Alter the index to an index that is not padded.

```
ALTER INDEX X1
NOT PADDED;
```

The index is placed in restricted rebuild-pending status (RBDP) and cannot be accessed until it is rebuilt from the table.

Example 4

Alter partitioned index DSN8C10.DEPT1. For partition 3, leave one page of free space for every 13 pages and 13 percent of free space per page. For partition 5, leave one page for every 25 pages and 25 percent of free space. For all the other partitions, leave one page of free space for every 6 pages and 11 percent of free space. Ensure that index pages are cached to the group buffer pool for all partitions except partition 4. For partition 4, write pages only when there is inter-Db2 read-write interest on the partition.

```
ALTER INDEX DSN8C10.XDEPT1
BUFFERPOOL BP1
CLOSE YES
COPY YES
USING VCAT CATLGG
FREEPAGE 6
PCTFREE 11
GBPCACHE ALL
ALTER PARTITION 3
USING VCAT CATLGG
FREEPAGE 13
PCTFREE 13,
ALTER PARTITION 4
USING VCAT CATLGG
GBPCACHE CHANGED,
ALTER PARTITION 5
USING VCAT CATLGG
FREEPAGE 25
PCTFREE 25;
```

ALTER MASK statement

The ALTER MASK statement changes a column mask that exists at the current server.

Invocation for ALTER MASK

This statement can be embedded in an application program or issued interactively. It is an executable statement that can be dynamically prepared only if DYNAMICRULES RUN behavior is in effect. For more information, see [“Authorization IDs and dynamic SQL”](#) on page 94.

Authorization for ALTER MASK

The privilege set that is defined below must include the following authority:

- SECADM authority

Privilege set: If the statement is embedded in an application program, the privilege set is the privileges that are held by the owner of the package. If the statement is dynamically prepared, the privilege set is the union of the privilege sets that are held by each authorization ID and role of the process.

Syntax for ALTER MASK

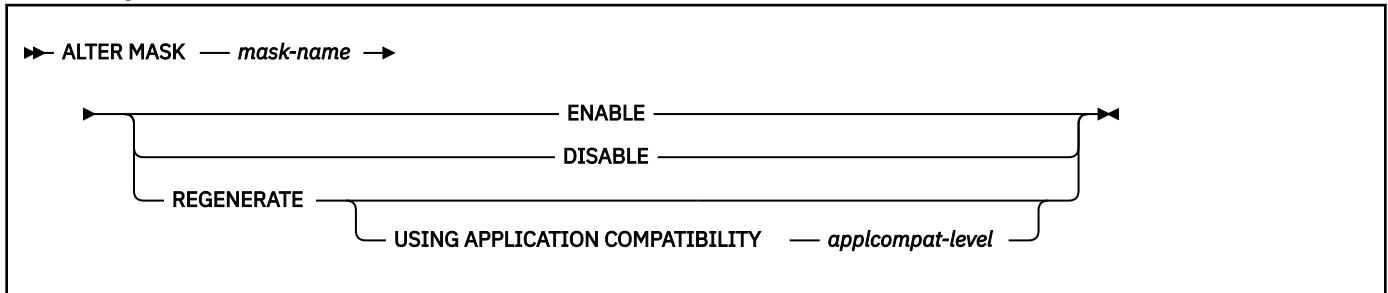

Description for ALTER MASK

mask-name

Identifies the column mask to be altered. The name must identify a mask that exists at the current server.

ENABLE

Specifies that the column mask is to be enabled for column access control. If column access control is not currently activated for the table, the column mask will become effective when column access control is activated for the table. If column access control is currently activated for the table, the column mask becomes effective immediately and dynamic cached statements that reference the table are invalidated. Use of this clause or keyword might invalidate packages that depend on the target object, or packages that depend on related objects through cascading effects. See [Changes that invalidate packages \(Db2 Application programming and SQL\)](#).

A column mask with a regeneration error cannot be enabled. To clear the status of the column mask, the column mask must be dropped and re-created with a modified definition.

ENABLE is ignored if the column mask is already defined as enabled for column access control.

DISABLE

Specifies that the column mask is to be disabled for column access control. If column access control is not currently activated for the table, the column mask will remain ineffective when column access control is activated for the table. If column access control is currently activated for the table, the column mask becomes ineffective immediately and all dynamic cached statements that reference the table are invalidated. Use of this clause or keyword might invalidate packages that depend on the target object, or packages that depend on related objects through cascading effects. See [Changes that invalidate packages \(Db2 Application programming and SQL\)](#).

DISABLE is ignored if the column mask is already defined as disabled for column access control.

REGENERATE

Specifies that the column mask is to be regenerated. The column mask definition in the catalog is used, and any existing dependencies and authorization are retained. The column mask definition is reevaluated as if the column mask was being created. The user-defined functions that are referenced in the column mask definition must be resolved to the same secure UDFs as that were resolved during the column mask creation.

Generally, the REGENERATE keyword is used only for specific situations, such as when implicit regeneration fails for routines or objects, or Db2 maintenance requires objects or routines to be

regenerated. For more information, see [When to regenerate Db2 database objects and routines \(Db2 Administration Guide\)](#).

USING APPLICATION COMPATIBILITY *applcompat-level*

Specifies that the object is regenerated under *applcompat-level* application compatibility rules. The ALTER statement fails if it includes any syntax, semantics, or options that require a higher application compatibility level.

If USING APPLICATION COMAPTIBILITY is omitted, the regeneration uses the APPLCOMPAT value of the applicable SYSIBM.SYSENVIRONMENT catalog table row.

The following *applcompat-level* values can be specified:

VvvRrMmmm

Compatibility with the behavior of the identified Db2 function level. For example, V12R1M510 specifies compatibility with the highest available Db2 12 function level. The equivalent function level or higher must be activated.

For the new capabilities that become available in each application compatibility level, see:

- [SQL changes in Db2 13 application compatibility levels](#)
- [SQL changes in Db2 12 application compatibility levels](#)

Tip: Extra program preparation steps might be required to increase the application compatibility level for applications that use data server clients or drivers to access Db2 for z/OS. For more information, see [Setting application compatibility levels for data server clients and drivers \(Db2 Application programming and SQL\)](#).

V12R1

Compatibility with the behavior of Db2 12 function level 500. This value has the same result as specifying V12R1M500.

V11R1

Compatibility with the behavior of Db2 11 new-function mode. After migration to Db2 12, this value has the same result as specifying V12R1M100. For more information, see [V11R1 application compatibility level \(Db2 Application programming and SQL\)](#)

V10R1

Compatibility with the behavior of DB2 10 new-function mode. For more information, see [V10R1 application compatibility level \(Db2 Application programming and SQL\)](#).

Notes for ALTER MASK

Applying Db2 maintenance:

When Db2 maintenance is applied that affects how a column mask is generated, the column mask might need to be regenerated to ensure the column mask is still valid.

If the column mask is regenerated successfully, the status of the column mask is set to a blank in the catalog table. If the column mask is enabled and column access control is currently activated for the table all dynamic cached statements that reference the table are invalidated.

If the column mask cannot be regenerated successfully, an error is returned. The regeneration status of the column mask is an error. If the column mask is enabled and column access control is currently activated for the table, all packages and dynamic cached statements that reference the table are marked invalidated. To clear the status of the column mask, the column mask must be dropped and re-created with a modified definition. Or the column mask can be disabled if not disabled yet. A disabled column mask becomes ineffective to a column access control enforced table.

When the table is referenced in a data manipulation statement, the statement returns an error if any enabled column mask has a regeneration error.

Invalidation of packages:

This statement might invalidate all packages that depend on target objects, and sometimes other related objects through cascading effects, depending on the clauses and keywords specified and other factors. For more information, see [Changes that invalidate packages \(Db2 Application programming and SQL\)](#).

Examples for ALTER MASK

Example 1:

Enable column mask M1.

```
ALTER MASK M1 ENABLE;
```

Example 2:

Regenerate column mask M1.

```
ALTER MASK M1 REGENERATE;  
COMMIT;
```

ALTER PERMISSION statement

The ALTER PERMISSION statement alters a row permission that exists at the current server.

Invocation for ALTER PERMISSION

This statement can be embedded in an application program or issued interactively. It is an executable statement that can be dynamically prepared only if DYNAMICRULES RUN behavior is in effect. For more information, see [“Authorization IDs and dynamic SQL”](#) on page 94.

Authorization for ALTER PERMISSION

The privilege set that is defined below must include the following authority:

SECADM authority

Privilege set: If the statement is embedded in an application program, the privilege set is the privileges that are held by the owner of the package. If the statement is dynamically prepared, the privilege set is the union of the privilege sets that are held by each authorization ID and role of the process.

Syntax for ALTER PERMISSION

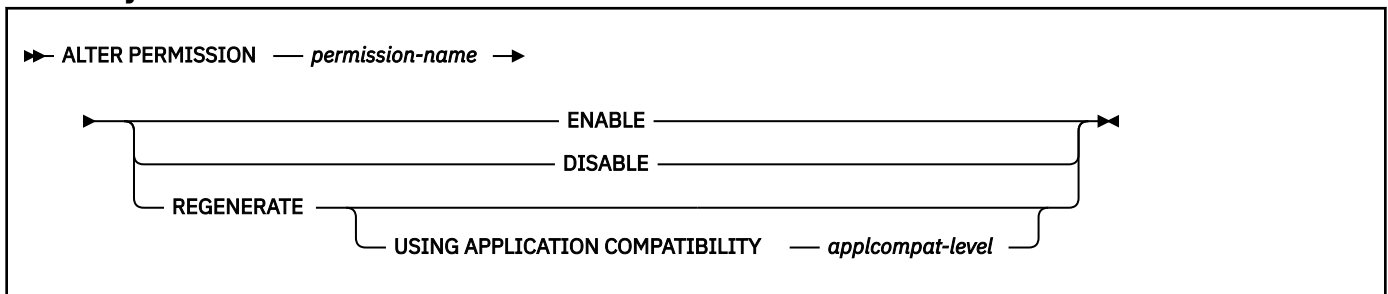

Description for ALTER PERMISSION

permission-name

Identifies the permission to be altered. The name must identify a row permission that exists at the current server. The name must not identify a default row permission that is created implicitly by Db2.

ENABLE

Specifies that the row permission is to be enabled for row access control. If row access control is not currently activated for the table, the row permission will become effective when row access control is activated for the table. Use of this clause or keyword might invalidate packages that depend on the target object, or packages that depend on related objects through cascading effects. See [Changes that invalidate packages \(Db2 Application programming and SQL\)](#).

A row permission with a regeneration error cannot be enabled. To clear the status of the row permission, the row permission must be dropped and re-created with a modified definition.

ENABLE is ignored if the row permission is already defined as enabled for row access control.

DISABLE

Specifies that the row permission is to be disabled for row access control. If row access control is not currently activated for the table, the row permission will remain ineffective when row access control is activated for the table. Use of this clause or keyword might invalidate packages that depend on the target object, or packages that depend on related objects through cascading effects. See [Changes that invalidate packages \(Db2 Application programming and SQL\)](#).

DISABLE is ignored if the row permission is already defined as disabled for row access control.

REGENERATE

Specifies that the row permission is to be regenerated. The row permission definition in the catalog is used, and any existing authorizations and dependencies are retained. The user-defined functions that are referenced in the row permission definition must be resolved to the same secure UDFs as that were resolved during the row permission creation.

Generally, the REGENERATE keyword is used only for specific situations, such as when implicit regeneration fails for routines or objects, or Db2 maintenance requires objects or routines to be regenerated. For more information, see [When to regenerate Db2 database objects and routines \(Db2 Administration Guide\)](#).

USING APPLICATION COMPATIBILITY *applcompat-level*

Specifies that the object is regenerated under *applcompat-level* application compatibility rules. The ALTER statement fails if it includes any syntax, semantics, or options that require a higher application compatibility level.

If USING APPLICATION COMAPTIBILITY is omitted, the regeneration uses the APPLCOMPAT value of the applicable SYSIBM.SYSENVIRONMENT catalog table row.

The following *applcompat-level* values can be specified:

VvvRrMmmm

Compatibility with the behavior of the identified Db2 function level. For example, V12R1M510 specifies compatibility with the highest available Db2 12 function level. The equivalent function level or higher must be activated.

For the new capabilities that become available in each application compatibility level, see:

- [SQL changes in Db2 13 application compatibility levels](#)
- [SQL changes in Db2 12 application compatibility levels](#)

Tip: Extra program preparation steps might be required to increase the application compatibility level for applications that use data server clients or drivers to access Db2 for z/OS. For more information, see [Setting application compatibility levels for data server clients and drivers \(Db2 Application programming and SQL\)](#).

V12R1

Compatibility with the behavior of Db2 12 function level 500. This value has the same result as specifying V12R1M500.

V11R1

Compatibility with the behavior of Db2 11 new-function mode. After migration to Db2 12, this value has the same result as specifying V12R1M100. For more information, see [V11R1 application compatibility level \(Db2 Application programming and SQL\)](#)

V10R1

Compatibility with the behavior of DB2 10 new-function mode. For more information, see [V10R1 application compatibility level \(Db2 Application programming and SQL\)](#).

Notes for ALTER PERMISSION**Invalidation of packages:**

This statement might invalidate all packages that depend on target objects, and sometimes other related objects through cascading effects, depending on the clauses and keywords specified and other factors. For more information, see [Changes that invalidate packages \(Db2 Application programming and SQL\)](#).

Invalidation of cached dynamic SQL statements:

This statement might invalidate cached dynamic SQL statements that depend on target objects, and sometimes other related objects through cascading effects. For more information, see [Invalidation of cached dynamic statements \(Db2 Performance\)](#).

Applying Db2 maintenance:

When Db2 maintenance is applied that affects how a row permission is generated, the row permission might need to be regenerated to ensure the row permission is still valid. For more information, see [When to regenerate Db2 database objects and routines \(Db2 Administration Guide\)](#).

If the row permission is regenerated successfully, the status of the row permission is set to a blank in the catalog table.

If the row permission cannot be regenerated successfully, an error is returned. The regeneration status of the row permission is set to an error. To clear the status of the row permission, the row permission must be dropped and re-created with a modified definition. Or the row permission can be disabled if not disabled yet. A disabled row permission becomes ineffective to a row access control enforced table.

When the table is referenced in a data manipulation statement, the statement returns an error if any enabled row permission has an regeneration error.

Examples for ALTER PERMISSION**Example 1**

Enable permission P1.

```
ALTER PERMISSION P1 ENABLE;
```

Example 2

Regenerate permission P1.

```
ALTER PERMISSION P1 REGENERATE;
```

ALTER PROCEDURE statement (external procedure)

The ALTER PROCEDURE statement changes the description of an external stored procedure at the current server.

Invocation for ALTER PROCEDURE (external)

This statement can be embedded in an application program or issued interactively. It is an executable statement that can be dynamically prepared only if DYNAMICRULES RUN behavior is in effect. For more information, see [“Authorization IDs and dynamic SQL”](#) on page 94.

Authorization for ALTER PROCEDURE (external)

The privilege set that is defined below must include at least one of the following:

- Ownership of the stored procedure
- The ALTERIN privilege on the schema
- SYSADM or SYSCTRL authority
- System DBADM
- Installation SYSOPR authority (when the current SQLID of the process is set to SYSINSTL)

The authorization ID that matches the schema name implicitly has the ALTERIN privilege on the schema.

If the authorization ID that is used to alter the procedure has the installation SYSADM authority or the installation SYSOPR authority and if the current SQLID is set to SYSINSTL, the procedure is identified as system-defined procedure when the procedure definition is reevaluated.

When LANGUAGE is JAVA and a *jar-name* is specified in the EXTERNAL NAME clause, the privilege set must include USAGE on the JAR file, the Java archive file.

Privilege set: If the statement is embedded in an application program, the privilege set is the privileges that are held by the owner of the package.

If the statement is dynamically prepared, the privilege set is the set of privileges that are held by the SQL authorization IDs of the process. The specified routine name can include a schema name (a qualifier). However, if the schema name is not the same as one of these SQL authorization IDs, one of the following conditions must be met:

1. The privilege set includes SYSADM authority
2. The privilege set includes SYSCTRL authority
3. The SQL authorization ID of the process has the ALTERIN privilege on the schema

If the environment in which the stored procedure is to run is being changed, the authorization ID must have authority to use the WLM environment. This authorization is obtained from an external security product, such as RACF. For more information, see [Managing authorizations for creation of stored procedures in WLM environments \(Managing Security\)](#).

Syntax for ALTER PROCEDURE (external)

```
▶ ALTER PROCEDURE — procedure-name — option-list ▶▶
```

option-list: (Specify options in any order. Specify at least one option. Do not specify the same option more than once.)

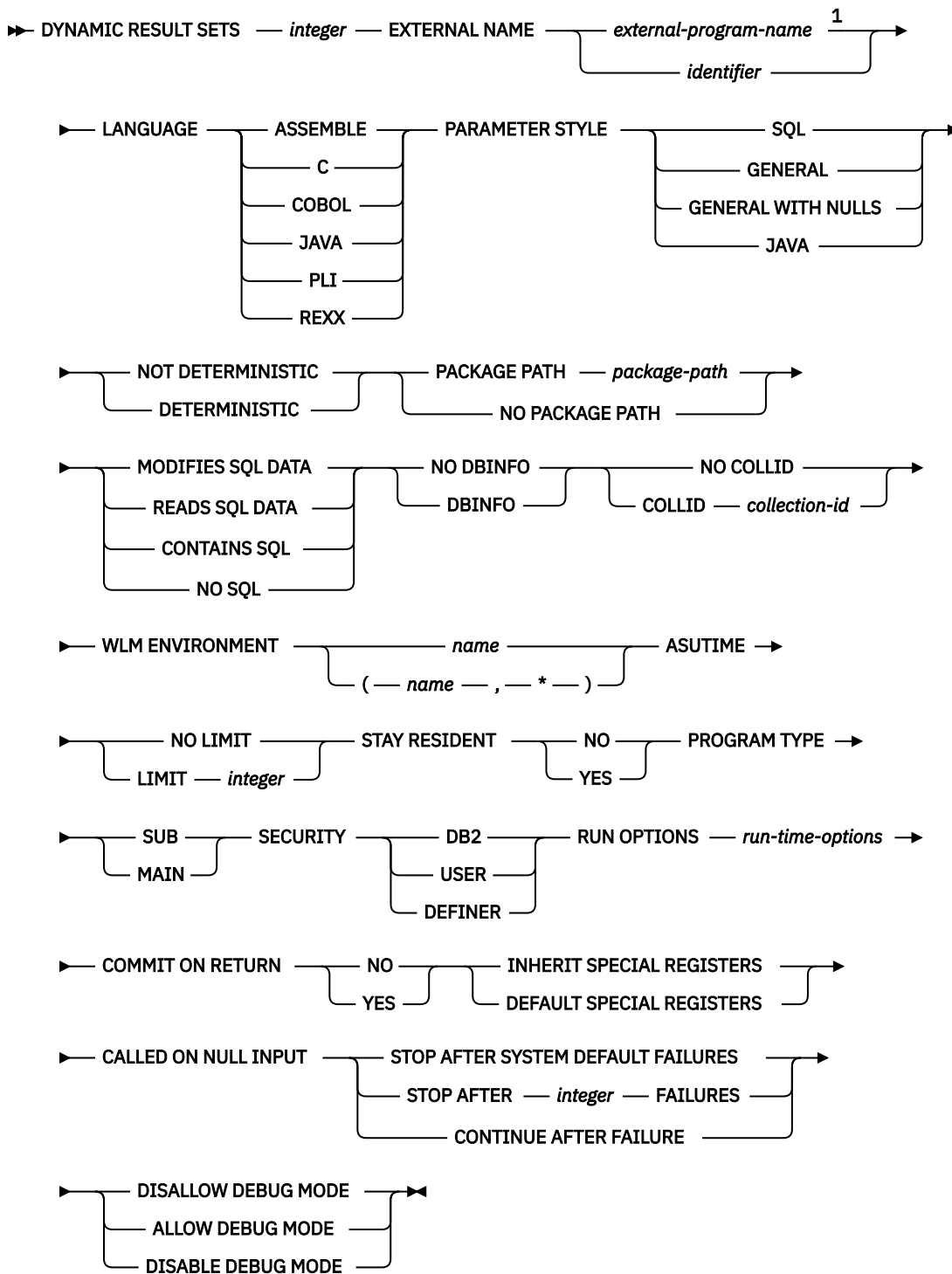

Notes:

¹ If LANGUAGE is JAVA, EXTERNAL NAME must be specified with a valid *external-java-routine-name*.



external-java-routine-name

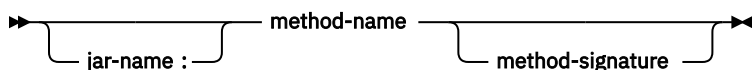

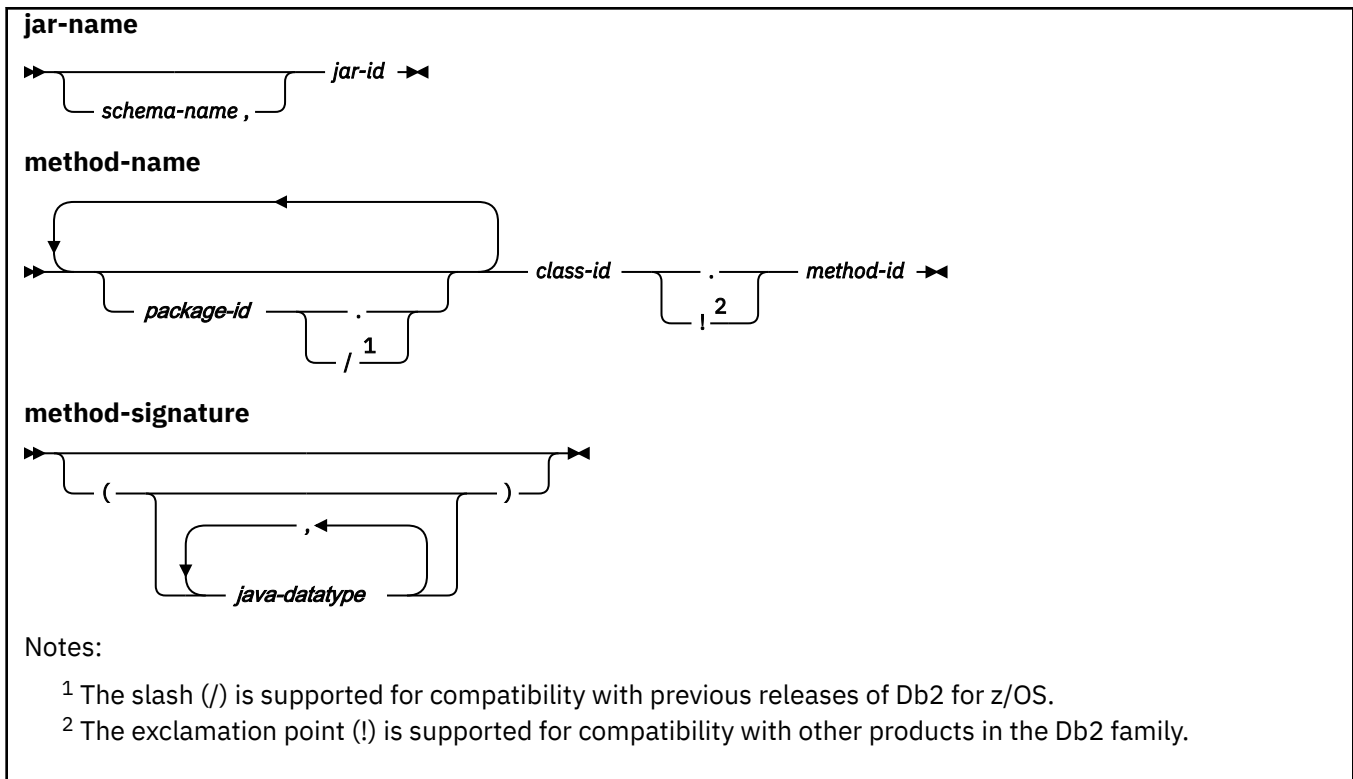

Description for ALTER PROCEDURE (external)

procedure-name

Identifies the stored procedure to be altered.

DYNAMIC RESULT SETS *integer*

Specifies the maximum number of query result sets that the stored procedure can return. The value must be in the range 0–32767.

EXTERNAL NAME *external-program-name or identifier*

Specifies the name of the MVS load module for the program that runs when the procedure name is specified in an SQL CALL statement.

If LANGUAGE is JAVA, *external-program-name* must be specified and enclosed in single quotation marks, with no extraneous blanks within the single quotation marks. It must specify a valid *external-java-routine-name*. If multiple *external-program-name* values are specified, the total length of all of the values must not be greater than 1305 bytes and each value must be separated by a space or a line break. Do not specify a JAR file for a Java procedure for which NO SQL is in effect.

An *external-java-routine-name* contains the following parts:

jar-name

Identifies the name given to the JAR file when it was installed in the database. The name contains *jar-id*, which can optionally be qualified with a schema. Examples are "myJar" and "mySchema.myJar." The unqualified *jar-id* is implicitly qualified with a schema name according to the following rules:

- If the statement is embedded in a program, the schema name is the authorization ID in the **QUALIFIER** bind option when the package or plan was created or last rebound. If the **QUALIFIER** was not specified, the schema name is the owner of the package or plan.
- If the statement is dynamically prepared, the schema name is the SQL authorization ID in the CURRENT SCHEMA special register.

If *jar-name* is specified, it must exist when the ALTER PROCEDURE statement is processed.

If *jar-name* is not specified, the procedure is loaded from the class file directly instead of being loaded from a JAR file. Db2 searches the directories in the CLASSPATH associated with the WLM Environment. Environmental variables for Java routines are specified in a data set identified in a JAVAENV DD card on the JCL used to start the address space for a WLM-managed stored procedure.

method-name

Identifies the name of the method and must not be longer than 254 bytes. Its package, class, and method ID's are specific to Java and as such are not limited to 18 bytes. In addition, the rules for what these can contain are not necessarily the same as the rules for an SQL ordinary identifier.

package-id

Identifies a package. The concatenated list of *package-ids* identifies the package that the class identifier is part of. If the class is part of a package, the method name must include the complete package prefix, such as "myPacks.StoredProcs." The Java virtual machine looks in the directory "/myPacks/StoredProcs/" for the classes.

class-id

Identifies the class identifier of the Java object.

method-id

Identifies the method identifier with the Java class to be invoked.

method-signature

Identifies a list of zero or more Java data types for the parameter list and must not be longer than 1024 bytes. Specify the *method-signature* if the procedure involves any input or output parameters that can be NULL. When the stored procedure being created is called, Db2 searches for a Java method with the exact *method-signature*. The number of *java-datatype* elements specified indicates how many parameters that the Java method must have.

A Java procedure can have no parameters. In this case, you code an empty set of parentheses for *method-signature*. If a Java *method-signature* is not specified, Db2 searches for a Java method with a signature derived from the default JDBC types associated with the SQL types specified in the parameter list of the ALTER PROCEDURE statement.

For other values of LANGUAGE, the value must conform to the naming conventions for MVS load modules: the value must be less than or equal to 8 bytes, and it must conform to the rules for an ordinary identifier with the exception that it must not contain an underscore.

LANGUAGE

Specifies the application programming language in which the stored procedure is written. Assembler, C, COBOL, and PL/I programs must be designed to run in IBM's Language Environment.

ASSEMBLE

The stored procedure is written in Assembler.

C

The stored procedure is written in C or C++.

COBOL

The stored procedure is written in COBOL, including the OO-COBOL language extensions.

JAVA

The stored procedure is written in Java and is executed in the Java Virtual Machine. When LANGUAGE JAVA is specified, the EXTERNAL NAME clause must also be specified with a valid *external-java-routine-name* and PARAMETER STYLE must be specified with JAVA. The procedure must be a public static method of the specified Java class.

Do not specify LANGUAGE JAVA when DBINFO, PROGRAM TYPE MAIN, or RUN OPTIONS is in effect.

PLI

The stored procedure is written in PL/I.

REXX

The stored procedure is written in REXX. Do not specify LANGUAGE REXX when PARAMETER STYLE SQL is specified.

PARAMETER STYLE

Identifies the linkage convention used to pass parameters to and return values from the stored procedure. All of the linkage conventions provide arguments to the stored procedure that contain the parameters specified on the CALL statement. Some of the linkage conventions pass additional arguments to the stored procedure that provide more information to the stored procedure. For more information on linkage conventions, see [Linkage conventions for external stored procedures \(Db2 Application programming and SQL\)](#).

SQL

Specifies that, in addition to the parameters on the CALL statement, several additional parameters are passed to the stored procedure. The following parameters are passed:

- The first *n* parameters that are specified on the CREATE PROCEDURE statement.
- *n* parameters for indicator variables for the parameters.
- The SQLSTATE to be returned.
- The qualified name of the stored procedure.
- The specific name of the stored procedure.
- The SQL diagnostic string to be returned to Db2.
- If DBINFO is specified, the DBINFO structure.

Do not specify PARAMETER STYLE SQL when LANGUAGE REXX is specified.

GENERAL

Specifies that the stored procedure uses a parameter passing mechanism where the stored procedure receives only the parameters specified on the CALL statement. Arguments to procedures defined with this parameter style cannot be null.

GENERAL WITH NULLS

Specifies that, in addition to the parameters on the CALL statement as specified in GENERAL, another argument is also passed to the stored procedure. The additional argument contains an indicator array with an element for each of the parameters on the CALL statement. In C, this is an array of short integers. The indicator array enables the stored procedure to accept or return null parameter values.

JAVA

Specifies that the stored procedure uses a parameter passing convention that conforms to the Java and SQLJ Routines specifications. PARAMETER STYLE JAVA can be specified only if LANGUAGE is JAVA. If the ALTER PROCEDURE statement results in changing LANGUAGE to JAVA, PARAMETER STYLE JAVA, and an EXTERNAL NAME clause might need to be specified to provide appropriate values. JAVA must be specified for PARAMETER STYLE when LANGUAGE is JAVA.

INOUT and OUT parameters are passed as single-entry arrays. The INOUT and OUT parameters are declared in the Java method as single-element arrays of the Java type.

PARAMETER STYLE SQL cannot be used with LANGUAGE REXX.

DETERMINISTIC or NOT DETERMINISTIC

Specifies whether the stored procedure returns the same results each time the stored procedure is called with the same IN and INOUT arguments.

DETERMINISTIC

The stored procedure always returns the same results each time the stored procedure is called with the same IN and INOUT arguments, if the referenced data in the database has not changed.

NOT DETERMINISTIC

The stored procedure might not return the same result each time the procedure is called with the same IN and INOUT arguments, even when the referenced data in the database has not changed.

Db2 does not verify that the stored procedure code is consistent with the specification of DETERMINISTIC or NOT DETERMINISTIC.

NO PACKAGE PATH or PACKAGE PATH *package-path*

Identifies the package path to use when the procedure is run. This is the list of the possible package collections into which the DBRM this is associated with the procedure is bound.

NO PACKAGE PATH

Specifies that the list of package collections for the procedure is the same as the list of package collections for the calling program. If the calling program does not use a package, Db2 resolves the package by using the CURRENT PACKAGE PATH special register, the CURRENT PACKAGESET special register, or the **PKLIST** bind option (in this order). For information about how Db2 uses these three items, see [Binding an application plan \(Db2 Application programming and SQL\)](#).

PACKAGE PATH *package-path*

Specifies a list of package collections, in the same format as used in the CURRENT PACKAGE PATH special register.

If the COLLID clause is specified with PACKAGE PATH, the COLLID clause is ignored when the routine is invoked.

The *package-path* value that is associated with the procedure definition is checked when the procedure is invoked. If *package-path* contains SESSION_USER, USER, PATH, or PACKAGE PATH, an error is returned when the *package-path* value is checked.

MODIFIES SQL DATA, READS SQL DATA, CONTAINS SQL, or NO SQL

Specifies the classification of SQL statements and nested routines that this routine can execute or invoke. The database manager verifies that the SQL statements issued by the procedure, and all routines locally invoked by the routine, are consistent with this specification; the verification is not performed when nested remote routines are invoked. For the classification of each statement, see [Appendix D, “SQL statement data access classification for routines,” on page 2275](#).

MODIFIES SQL DATA

Specifies that the procedure can execute any SQL statement except statements that are not supported in procedures.

READS SQL DATA

Specifies that procedure can execute statements with a data access indication of READS SQL DATA, CONTAINS SQL, or NO SQL. The procedure cannot execute SQL statements that modify data.

CONTAINS SQL

Specifies that the procedure can execute only SQL statements with an access indication of CONTAINS SQL. The procedure cannot execute statements that read or modify data.

NO SQL

Specifies that the procedure can execute only SQL statements with a data access classification of NO SQL. Do not specify NO SQL for a Java procedure that uses a JAR file.

NO DBINFO or DBINFO

Specifies whether additional status information is passed to the stored procedure when it is invoked.

NO DBINFO

Additional information is not passed.

DBINFO

An additional argument is passed when the stored procedure is invoked. The argument is a structure that contains information such as the application run time authorization ID, the schema name, the name of a table or column that the procedure might be inserting into or updating, and identification of the database server that invoked the procedure. For details about the argument and its structure, see [DBINFO structure \(Db2 Application programming and SQL\)](#).

DBINFO can be specified only if PARAMETER STYLE SQL is specified.

NO COLLID or COLLID *collection-id*

Identifies the package collection that is to be used when the stored procedure is executed. This is the package collection into which the DBRM that is associated with the stored procedure is bound.

NO COLLID

Specifies that the package collection for the stored procedure is the same as the package collection of the calling program. If the invoking program does not use a package, Db2 resolves the package by using the CURRENT PACKAGE PATH special register, the CURRENT PACKAGESET special register, or the **PKLIST** bind option (in this order). For details about how Db2 uses these three items, see the information on package resolution in [Binding an application plan \(Db2 Application programming and SQL\)](#).

COLLID *collection-id*

Identifies the package collection that is to be used when the stored procedure is executed. It is the name of the package collection into which the DBRM associated with the stored procedure is bound.

For REXX stored procedures, *collection-id* can be DSNREXRR, DSNREXRS, DSNREXCR, or DSNREXCS.

WLM ENVIRONMENT

Identifies the WLM (workload manager) environment in which the stored procedure is to run when the Db2 stored procedure address space is WLM-established. The *name* of the WLM environment is an SQL identifier.

name

The WLM environment in which the stored procedure must run. If another stored procedure or a user-defined function calls the stored procedure and that calling routine is running in an address space that is not associated with the specified WLM environment, Db2 routes the stored procedure request to a different address space.

(name,*)

When the stored procedure is called directly by an SQL application program, the WLM environment in which the stored procedure runs.

If another stored procedure or a user-defined function calls the stored procedure, the stored procedure runs in the same WLM environment that the calling routine uses.

You must have appropriate authority for the WLM environment. [Managing authorizations for creation of stored procedures in WLM environments \(Managing Security\)](#).-->

ASUTIME

Specifies the total amount of processor time, in CPU service units, that a single invocation of a stored procedure can run. The value is unrelated to the ASUTIME column in the resource limit specification table.

When you are debugging a stored procedure, setting a limit can be helpful in case the stored procedure gets caught in a loop. For information on CPU service units, see [z/OS MVS Initialization and Tuning Guide](#).

NO LIMIT

There is no limit on the service units.

LIMIT *integer*

The limit on the service units is a positive *integer* in the range 1–2147483647. If the stored procedure uses more service units than the specified value, Db2 cancels the stored procedure.

STAY RESIDENT

Specifies whether the stored procedure load module is to remain resident in memory when the stored procedure ends.

NO

The load module is deleted from memory after the stored procedure ends. Use NO for non-reentrant stored procedures.

YES

The load module remains resident in memory after the stored procedure ends.

PROGRAM TYPE

Specifies whether the stored procedure runs as a main routine or a subroutine. If PROGRAM TYPE is altered, the stored procedure needs to be re-compiled for the change to take effect.

SUB

The stored procedure runs as a subroutine.

Do not specify PROGRAM TYPE SUB for stored procedures with a LANGUAGE value of REXX.

MAIN

The stored procedure runs as a main routine.

Do not specify PROGRAM TYPE MAIN when LANGUAGE JAVA is specified.

SECURITY

Specifies how the stored procedure interacts with an external security product, such as RACF, to control access to non-SQL resources.

DB2

The stored procedure does not require a special external security environment. If the stored procedure accesses resources that an external security product protects, the access is performed using the authorization ID associated with the stored procedure address space.

USER

An external security environment should be established for the stored procedure. If the stored procedure accesses resources that the external security product protects, the access is performed using the authorization ID of the user who invoked the stored procedure.

DEFINER

An external security environment should be established for the stored procedure. If the stored procedure accesses resources that the external security product protects, the access is performed using the authorization ID of the owner of the stored procedure.

RUN OPTIONS *run-time-options*

Specifies the Language Environment run time options to be used for the stored procedure. For a REXX stored procedure, specifies the Language Environment run time options to be passed to the REXX language interface to Db2. You must specify *run-time-options* as a character string that is no longer than 254 bytes. To replace any existing run time options with no options, specify an empty string with RUN OPTIONS. When you specify an empty string, Db2 does not pass any run time options to Language Environment, and Language Environment uses its installation defaults. For a description of the Language Environment run time options, see [Language Environment Programming Reference \(z/OS Language Environment Programming Reference\)](#).

Do not specify RUN OPTIONS when LANGUAGE JAVA is specified.

COMMIT ON RETURN

Indicates whether Db2 is to commit the transaction immediately on return from the stored procedure.

NO

Db2 does not issue a commit when the stored procedure returns.

YES

Db2 issues a commit when the stored procedure returns if the following statements are true:

- The SQLCODE that is returned by the CALL statement is not negative.
- The stored procedure is not in a must abort state.

The commit operation includes the work that is performed by the calling application process and the stored procedure.

If the stored procedure returns result sets, the cursors that are associated with the result sets must have been defined WITH HOLD to be usable after the commit.

INHERIT SPECIAL REGISTERS or DEFAULT SPECIAL REGISTERS

Specifies how special registers are set on entry to the routine.

INHERIT SPECIAL REGISTERS

Indicates that values of special registers are inherited according to the rules listed in the table for characteristics of special registers in a stored procedure in [“Special registers in a user-defined function or a stored procedure”](#) on page 215.

DEFAULT SPECIAL REGISTERS

Indicates that special registers are initialized to the default values, as indicated by the rules in the table for characteristics of special registers in a stored procedure in [“Special registers in a user-defined function or a stored procedure”](#) on page 215.

CALLED ON NULL INPUT

Specifies that the procedure is to be called even if any or all of the argument values are null, which means that the procedure must be coded to test for null argument values. The procedure can return null or nonnull values.

STOP AFTER SYSTEM DEFAULT FAILURES, STOP AFTER *nn* FAILURES, or CONTINUE AFTER FAILURE

Specifies whether the routine is to be put in a stopped state after some number of failures.

STOP AFTER SYSTEM DEFAULT FAILURES

Specifies that this routine should be placed in a stopped state after the number of failures indicated by the value of field MAX ABEND COUNT on installation field DSNTIPX.

STOP AFTER *nn* FAILURES

Specifies that this routine should be placed in a stopped state after *nn* failures. The value *nn* can be an integer 1–32767.

CONTINUE AFTER FAILURE

Specifies that this routine should not be placed in a stopped state after any failure.

ALLOW DEBUG MODE, DISALLOW DEBUG MODE, or DISABLE DEBUG MODE

Specifies whether the procedure can be run in debugging mode.

Do not specify this option unless the procedure is defined with LANGUAGE JAVA.

ALLOW DEBUG MODE

Specifies that the procedure can be run in debugging mode.

DISALLOW DEBUG MODE

Specifies that the procedure cannot be run in debugging mode.

You can use a subsequent ALTER PROCEDURE statement to change this option to ALLOW DEBUG MODE.

DISABLE DEBUG MODE

Specifies that the procedure can never be run in debugging mode.

The procedure cannot be changed to specify ALLOW DEBUG MODE or DISALLOW DEBUG MODE when the procedure has been created or altered to use DISABLE DEBUG MODE. To change this option, you must drop and re-create the procedure using the option that you want.

Notes for ALTER PROCEDURE (external)

Invalidation of packages: When an external procedure is altered, all the packages that refer to that procedure are marked invalid.

LANGUAGE C and the PARAMETER VARCHAR clause: The ALTER PROCEDURE statement does not allow you to alter the value of the PARAMETER VARCHAR or PARAMETER CCSID clauses that are associated with the procedure definition. However, you can alter the LANGUAGE clause for the procedure. If the PARAMETER VARCHAR clause is specified for the creation of a LANGUAGE C procedure, the catalog information for that option is not affected by subsequent ALTER PROCEDURE statements. The procedure might be changed to a language other than C, in which case the PARAMETER VARCHAR setting is ignored.

If the procedure is later changed back to LANGUAGE C, the setting of the PARAMETER VARCHAR option that was specified for the CREATE PROCEDURE statement (which is still in the catalog) will be used.

Alternative syntax and synonyms: To provide compatibility with previous releases of Db2 or other products in the Db2 family, Db2 supports the following keywords:

- DYNAMIC RESULT SET, RESULT SET, and RESULT SETS as synonyms for DYNAMIC RESULT SETS
- STANDARD CALL as a synonym for DB2SQL
- SIMPLE CALL as a synonym for GENERAL
- SIMPLE CALL WITH NULLS as a synonym for GENERAL WITH NULLS
- VARIANT as a synonym for NOT DETERMINISTIC
- NOT VARIANT as a synonym for DETERMINISTIC
- NULL CALL as a synonym for CALLED ON NULL INPUT
- PARAMETER STYLE DB2SQL as a synonym for PARAMETER STYLE SQL

Examples for ALTER PROCEDURE (external)

Example 1

Assume that stored procedure SYSPROC.MYPROC is currently defined to run in WLM environment PARTSA and that you have appropriate authority on that WLM environment and WLM environment PARTSEC. Change the definition of the stored procedure so that it runs in PARTSEC.

```
ALTER PROCEDURE SYSPROC.MYPROC WLM ENVIRONMENT PARTSEC;
```

Related tasks

[Altering stored procedures \(Db2 Administration Guide\)](#)

ALTER PROCEDURE statement (SQL - external procedure) (deprecated)

The ALTER PROCEDURE statement changes the description, at the current server, of an external SQL procedure.

Deprecated function: External SQL procedures are deprecated and not as fully supported as native SQL procedures. For best results, create native SQL procedures instead. For more information, see [Creating native SQL procedures \(Db2 Application programming and SQL\)](#) and [Migrating an external SQL procedure to a native SQL procedure \(Db2 Application programming and SQL\)](#).

Invocation for ALTER PROCEDURE (SQL - external)

This statement can be embedded in an application program or issued interactively. It is an executable statement that can be dynamically prepared only if DYNAMICRULES RUN behavior is in effect. For more information, see [“Authorization IDs and dynamic SQL” on page 94](#).

Authorization for ALTER PROCEDURE (SQL - external)

The privilege set that is defined below must include at least one of the following:

- Ownership of the stored procedure
- The ALTERIN privilege on the schema
- SYSADM or SYSCTRL authority
- System DBADM
- Installation SYSOPR authority (when the current SQLID of the process is set to SYSINSTL)

The authorization ID that matches the schema name implicitly has the ALTERIN privilege on the schema.

If the authorization ID that is used to alter the procedure has the installation SYSADM authority or the installation SYSOPR authority and if the current SQLID is set to SYSINSTL, the procedure is identified as system-defined procedure when the procedure definition is reevaluated.

Privilege set: If the statement is embedded in an application program, the privilege set is the privileges that are held by the owner of the package.

If the statement is dynamically prepared, the privilege set is the set of privileges that are held by the SQL authorization IDs of the process. The specified routine name can include a schema name (a qualifier). However, if the schema name is not the same as one of these SQL authorization IDs, one of the following conditions must be met:

1. The privilege set includes SYSADM authority
2. The privilege set includes SYSCTRL authority
3. The SQL authorization ID of the process has the ALTERIN privilege on the schema

The SQL authorization ID that is used to alter the procedure definition must have appropriate authority for the WLM environment in which the procedure is currently defined to run. This authorization is obtained from an external security product, such as RACF. For more information, see [Managing authorizations for creation of stored procedures in WLM environments \(Managing Security\)](#).

Syntax for ALTER PROCEDURE (SQL - external)

▶▶ ALTER PROCEDURE — *procedure-name* — option-list ▶▶

option-list: (Specify options in any order. Specify at least one option. Do not specify the same option more than once.)

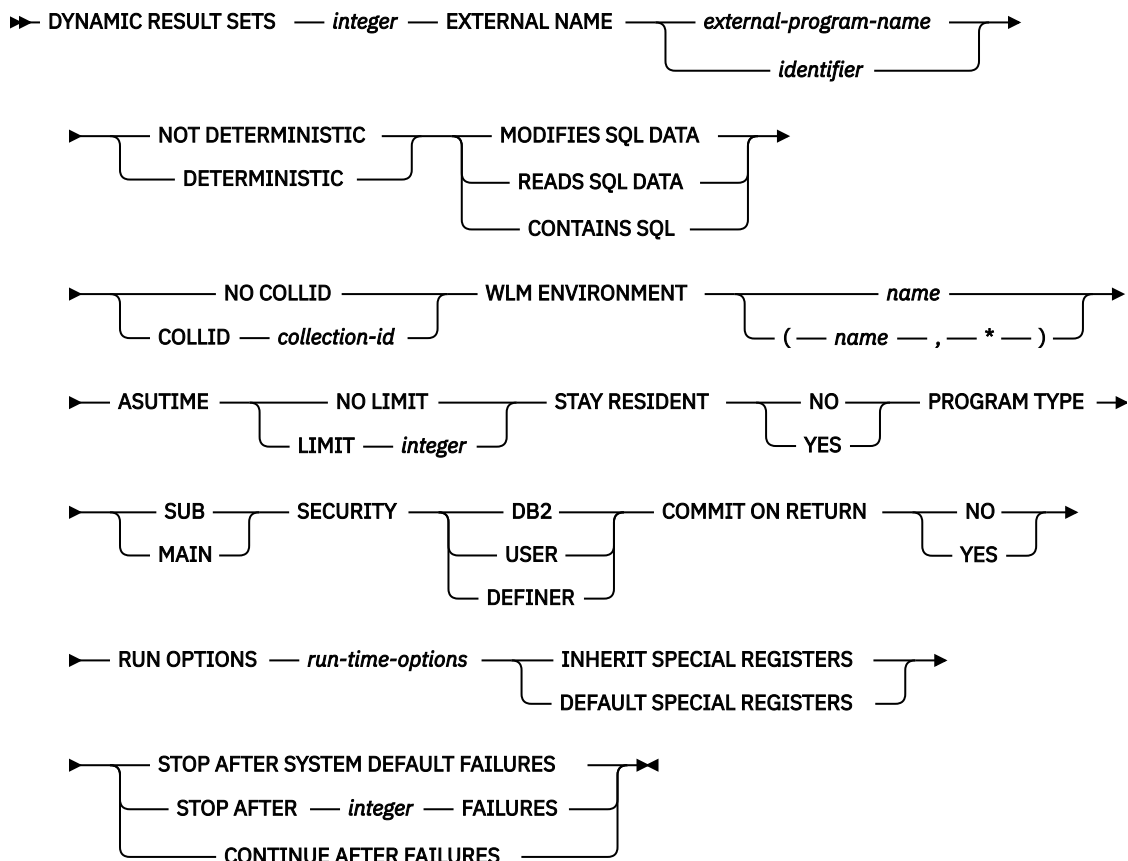

Description for ALTER PROCEDURE (SQL - external)

procedure-name

Identifies the stored procedure to be altered.

DYNAMIC RESULT SETS *integer*

Specifies the maximum number of query result sets that the procedure can return. The value must be in the range 0–32767.

EXTERNAL NAME *external-program-name or identifier*

Specifies the name of the MVS load module for the program that runs when the procedure name is specified in an SQL CALL statement. The value must conform to the naming conventions for MVS load modules: the value must be less than or equal to 8 bytes, and it must conform to the rules for an ordinary identifier with the exception that it must not contain an underscore.

NOT DETERMINISTIC or DETERMINISTIC

Specifies whether the procedure returns the same results each time the procedure is called with the same IN and INOUT arguments.

NOT DETERMINISTIC

The procedure might not return the same result each time the procedure is called with the same IN and INOUT arguments, even when the referenced data in the database has not changed.

DETERMINISTIC

The procedure always returns the same results each time the procedure is called with the same IN and INOUT arguments, if the referenced data in the database has not changed.

Db2 does not verify that the procedure code is consistent with the specification of DETERMINISTIC or NOT DETERMINISTIC.

MODIFIES SQL DATA, READS SQL DATA, or CONTAINS SQL

Specifies the classification of SQL statements and nested routines that this routine can execute or invoke. The database manager verifies that the SQL statements issued by the procedure, and all routines locally invoked by the routine, are consistent with this specification; the verification is not performed when nested remote routines are invoked. For the classification of each statement, see [Appendix D, “SQL statement data access classification for routines,”](#) on page 2275. Statements that are not supported in any procedure will return an error.

MODIFIES SQL DATA

Specifies that the procedure can execute any SQL statement except statements that are not supported in procedures.

READS SQL DATA

Specifies that procedure can execute statements with a data access indication of READS SQL DATA or CONTAINS SQL. The procedure cannot execute SQL statements that modify data.

CONTAINS SQL

Specifies that the procedure can execute only SQL statements with an access indication of CONTAINS SQL. The procedure cannot execute statements that read or modify data.

NO COLLID or COLLID *collection-id*

Identifies the package collection that is to be used when the procedure is executed. This is the package collection into which the DBRM that is associated with the procedure is bound.

NO COLLID

Indicates that the package collection for the procedure is the same as the package collection of the calling program. If the invoking program does not use a package, Db2 resolves the package by using the CURRENT PACKAGE PATH special register, the CURRENT PACKAGESET special register, or the **PKLIST** bind option (in this order). For details about how Db2 uses these three items, see the information on package resolution in [Binding an application plan \(Db2 Application programming and SQL\)](#).

COLLID *collection-id*

Specifies the package collection for the procedure.

WLM ENVIRONMENT *name* or (*name*,*)

Identifies the WLM (workload manager) environment in which the procedure is to run when the Db2 stored procedure address space is WLM-established. The *name* of the WLM environment is an SQL identifier.

name

Specifies the WLM environment in which the procedure must run. If another routine calls the procedure and that calling routine is running in an address space that is not associated with the specified WLM environment, Db2 routes the procedure request to a different address space.

(*name*,*)

When an SQL application program directly calls a procedure, *name* specifies the WLM environment in which the stored procedure runs.

If another routine calls the procedure, the procedure runs in the same WLM environment that the calling routine uses.

You must have appropriate authority for the WLM environment.

ASUTIME

Specifies the total amount of processor time, in CPU service units, that a single invocation of a procedure can run. The value is unrelated to the ASUTIME column of the resource limit specification table.

When you are debugging a procedure, setting a limit can be helpful in case the procedure gets caught in a loop. For information on service units, see [z/OS MVS Initialization and Tuning Guide](#).

NO LIMIT

There is no limit on the number of CPU service units that the procedure can run.

LIMIT *integer*

The limit on the number of CPU service units is a positive *integer* in the range 1–2147483647.

If the procedure uses more service units than the specified value, Db2 cancels the procedure.

The CPU cycles that are consumed by parallel tasks in a procedure do not contribute towards the specified ASUTIME LIMIT.

STAY RESIDENT

Specifies whether the load module for the procedure is to remain resident in memory when the procedure ends.

NO

The load module is deleted from memory after the procedure ends.

YES

The load module remains resident in memory after the procedure ends.

PROGRAM TYPE

Specifies whether the procedure runs as a main routine or a subroutine. If PROGRAM TYPE is altered, the stored procedure needs to be re-compiled for the change to take effect.

SUB

The procedure runs as a subroutine.

MAIN

The procedure runs as a main routine.

SECURITY

Specifies how the procedure interacts with an external security product, such as RACF, to control access to non-SQL resources.

DB2

The procedure does not require a special external security environment. If the procedure accesses resources that an external security product protects, the access is performed using the authorization ID that is associated with the address space in which the procedure runs.

USER

An external security environment should be established for the procedure. If the procedure accesses resources that the external security product protects, the access is performed using the authorization ID of the user who invoked the procedure.

DEFINER

An external security environment should be established for the procedure. If the procedure accesses resources that the external security product protects, the access is performed using the authorization ID of the owner of the procedure.

RUN OPTIONS *run-time-options*

Specifies the Language Environment run time options that are to be used for the procedure. You must specify *run-time-options* as a character string that is no longer than 254 bytes. If you do not specify `RUN OPTIONS` or pass an empty string, Db2 does not pass any run time options to Language Environment, and Language Environment uses its installation defaults.

For a description of the Language Environment run time options, see [Language Environment Programming Reference \(z/OS Language Environment Programming Reference\)](#).

COMMIT ON RETURN

Indicates whether Db2 commits the transaction immediately on return from the procedure.

NO

Db2 does not issue a commit when the procedure returns.

YES

Db2 issues a commit when the procedure returns if the following statements are true:

- A positive SQLCODE is returned by the CALL statement.
- The procedure is not in a must abort state.

The commit operation includes the work that is performed by the calling application process and the procedure.

If the procedure returns result sets, the cursors that are associated with the result sets must have been defined as WITH HOLD to be usable after the commit.

INHERIT SPECIAL REGISTERS or DEFAULT SPECIAL REGISTERS

Specifies how special registers are set on entry to the routine.

INHERIT SPECIAL REGISTERS

Specifies that special registers should be inherited according to the rules listed in the table for characteristics of special registers in a procedure in [Table 47 on page 215](#).

DEFAULT SPECIAL REGISTERS

Specifies that special registers should be initialized to the default values, as indicated by the rules in the table for characteristics of special registers in a procedure in [Table 47 on page 215](#).

STOP AFTER SYSTEM DEFAULT FAILURES, STOP AFTER *nn* FAILURES, or CONTINUE AFTER FAILURE

Specifies if the routine is stopped after failures.

STOP AFTER SYSTEM DEFAULT FAILURES

Specifies that this routine should be placed in a stopped state after the number of failures indicated by the value of field MAX ABEND COUNT on installation panel DSNTIPX.

STOP AFTER *nn* FAILURES

Specifies that this routine should be placed in a stopped state after *nn* failures. The value *nn* can be an integer 1–32767.

CONTINUE AFTER FAILURES

Specifies that this routine should not be placed in a stopped state after any failure.

Notes for ALTER PROCEDURE (SQL - external)

Changing to a native SQL procedure:

You cannot change an external SQL procedure to a native SQL procedure. You can drop the procedure that you want to change using the DROP statement and create a native SQL procedure with a similar definition using the CREATE PROCEDURE statement. Alternatively, you can create a native SQL procedure using a different schema.

For more information, see [Migrating an external SQL procedure to a native SQL procedure \(Db2 Application programming and SQL\)](#).

Invalidation of packages:

When an SQL procedure is altered, all packages that refer to that procedure are marked invalid.

Alternative syntax and synonyms:

To provide compatibility with previous releases of Db2 or other products in the Db2 UDB family, Db2 supports the following keywords:

- RESULT SET, RESULT SETS, and DYNAMIC RESULT SET as synonyms for DYNAMIC RESULT SETS.
- VARIANT as a synonym for NOT DETERMINISTIC
- NOT VARIANT as a synonym for DETERMINISTIC

Example for ALTER PROCEDURE (SQL - external)

The following statement, modifies the definition for an SQL procedure so that SQL changes are committed on return from the SQL procedure and the SQL procedure runs in the WLM environment named WLMSQLP.

```
ALTER PROCEDURE UPDATE_SALARY_1
  COMMIT ON RETURN YES
  WLM ENVIRONMENT WLMSQLP;
```

Related concepts

[External stored procedures \(Db2 Application programming and SQL\)](#)

Related tasks

[Altering stored procedures \(Db2 Administration Guide\)](#)

ALTER PROCEDURE statement (SQL - native procedure)

The ALTER PROCEDURE statement changes the definition of an SQL procedure at the current server. The procedure options, parameter names, and routine body can be changed and additional versions of the procedure can be defined and maintained using the ALTER PROCEDURE statement.

For information about the SQL control statements that are supported in native SQL procedures, refer to Chapter 8, “SQL procedural language (SQL PL),” on page 2207.

Invocation for ALTER PROCEDURE (SQL - native)

This can be dynamically prepared only if dynamic rules run behavior is in effect. For more information, see [“Authorization IDs and dynamic SQL” on page 94](#).

Authorization for ALTER PROCEDURE (SQL - native)

The privilege set that is defined below must include at least one of the following:

- Ownership of the procedure
- The ALTERIN privilege on the schema
- System DBADM
- SYSCTRL authority

- SYSADM
- Installation SYSOPR authority (when the current SQLID of the process is set to SYSINSTL)

The authorization ID that matches the schema name implicitly has the ALTERIN privilege on the schema.

If the authorization ID that is used to alter the procedure has the installation SYSADM authority or the installation SYSOPR authority and if the current SQLID is set to SYSINSTL, the procedure is identified as system-defined procedure when the procedure definition is reevaluated.

Additional privileges might be required in the following situations:

- If *SQL-routine-body* is specified, the privilege set must include the privileges that are required to execute the statements in *SQL-routine-body*.
- If a user-defined type is referenced (as the data type of a parameter or SQL variable), the privilege set must also include at least one of the following privileges or authorities:
 - Ownership of the user-defined type
 - The USAGE privilege on the user-defined type
 - System DBADM authority
 - DATAACCESS authority
 - SYSADM authority
- If the procedure uses a table as a parameter, the privilege set must also include at least one of the following privileges or authorities:
 - Ownership of the table
 - The SELECT privilege on the table
 - DATAACCESS authority
 - SYSADM authority
- If you specify the WLM ENVIRONMENT FOR DEBUG MODE clause, RACF or an external security product is invoked to check the required authority for defining programs in the WLM environment. If the WLM environment access is protected in RACF, the privilege set must include the required authority. For more information, see [Managing authorizations for creation of stored procedures in WLM environments \(Managing Security\)](#).
- When defining a new version of a procedure (using the ADD VERSION clause) or when replacing an existing version (using the REPLACE VERSION clause), the privilege set must include the required authorization to add a new package or a new version of an existing package depending on the value of the BIND NEW PACKAGE field on installation panel DSNTIPP, or the privilege set must include SYSADM or SYSCTRL authority.

Additional authorization may be required on the SYSDUMMYx tables depending on the content of the procedure definition. See [SYSDUMMYx tables](#).

Privilege set: If the statement is embedded in an application program, the privilege set is the privileges that are held by the owner of the package.

If the statement is dynamically prepared, the privilege set is the set of privileges that are held by the SQL authorization IDs of the process. The specified routine name can include a schema name (a qualifier). However, if the schema name is not the same as one of these SQL authorization IDs, one of the following conditions must be met:

1. The privilege set includes SYSADM authority
2. The privilege set includes SYSCTRL authority
3. The SQL authorization ID of the process has the ALTERIN privilege on the schema

When ALTER PROCEDURE is issued in a trusted context that has the ROLE AS OBJECT OWNER clause, the package owner is determined as follows:

- If the PACKAGE OWNER option is not specified, the role associated with the binder becomes the package owner.

- If the PACKAGE OWNER option is specified, the role specified in the PACKAGE OWNER option becomes the package owner. In a trusted context, the PACKAGE OWNER specified must be a role.

Syntax for ALTER PROCEDURE (SQL - native)

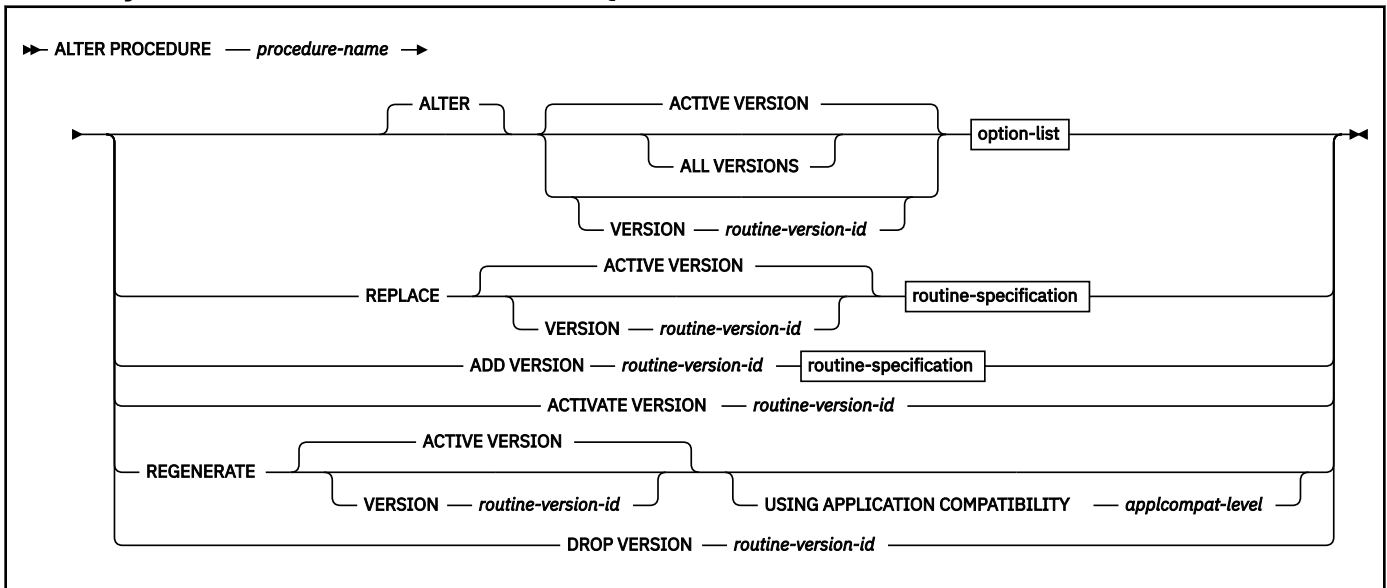

routine-specification:

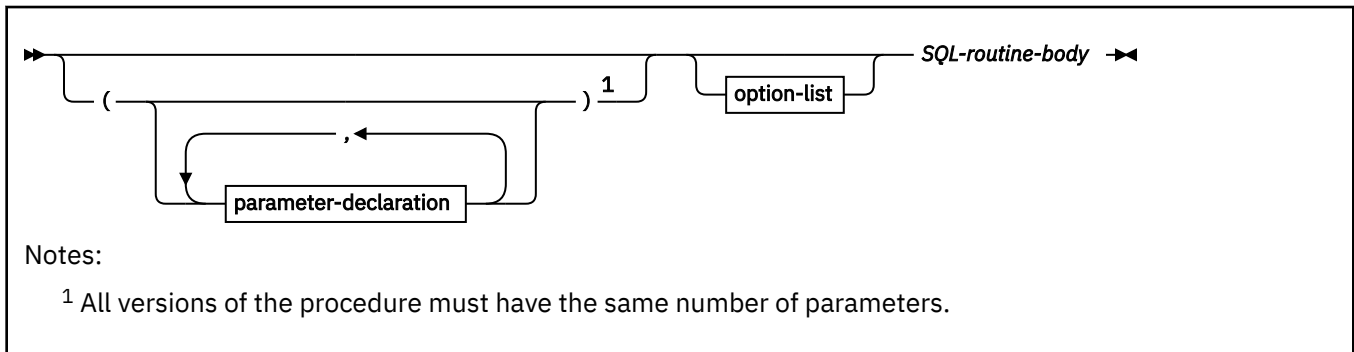

parameter-declaration:



data-type:



built-in-type:

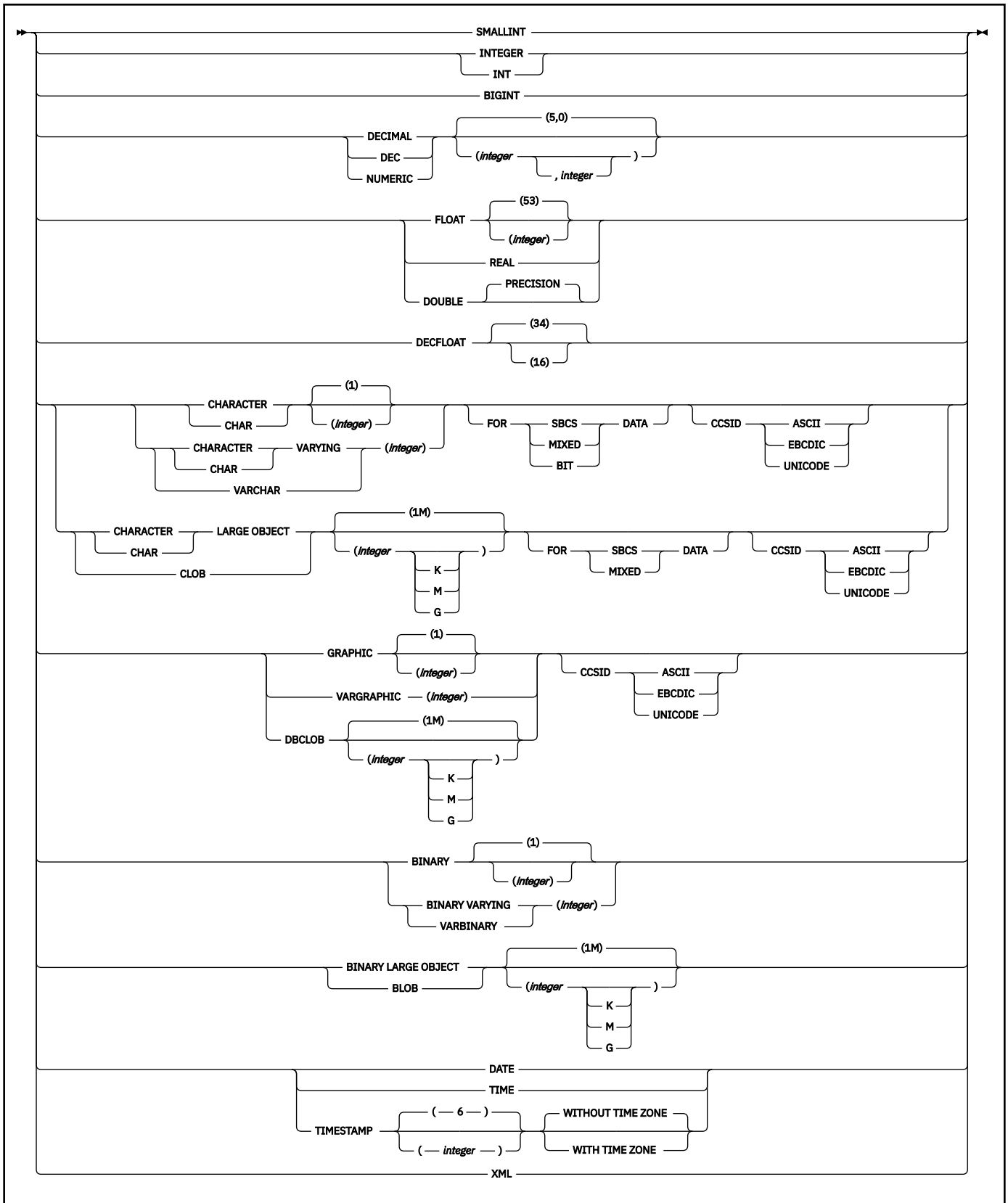

option-list: (The options can be specified in any order, but each option can be specified only one time.)

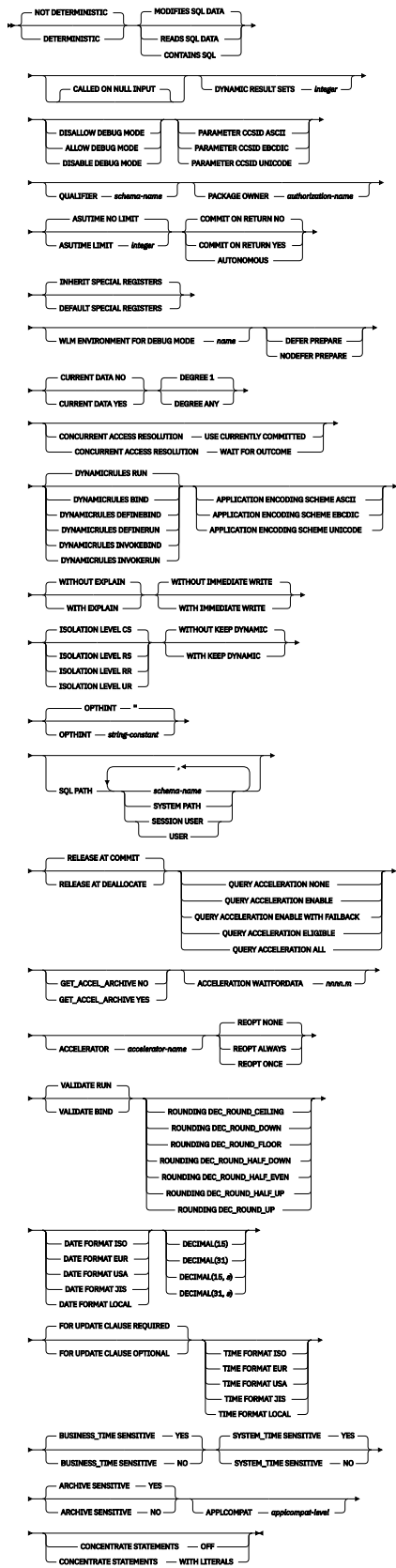

SQL-routine-body:

SQL-control-statement
ALTER DATABASE statement
ALTER FUNCTION statement (external scalar, external table, sourced, SQL scalar, or SQL table)
ALTER INDEX statement
ALTER PROCEDURE statement (external, SQL - external, or SQL - native)
ALTER SEQUENCE statement
ALTER STOGROUP statement
ALTER TABLE statement
ALTER TABLESPACE statement
ALTER TRUSTED CONTEXT statement
ALTER VIEW statement
COMMENT statement
COMMIT statement
CONNECT statement
CREATE ALIAS statement
CREATE DATABASE statement
CREATE FUNCTION statement (external scalar, external table, or sourced)
CREATE GLOBAL TEMPORARY TABLE statement
CREATE INDEX statement
CREATE PROCEDURE (external) statement
CREATE ROLE statement
CREATE SEQUENCE statement
CREATE STOGROUP statement
CREATE SYNONYM statement
CREATE TABLE statement
CREATE TABLESPACE statement
CREATE TRUSTED CONTEXT statement
CREATE TYPE statement
CREATE VIEW statement
DECLARE GLOBAL TEMPORARY TABLE statement
DELETE statement
DROP statement
EXCHANGE statement
EXECUTE IMMEDIATE statement
GRANT statement
INSERT statement
LABEL statement
LOCK TABLE statement
MERGE statement
REFRESH TABLE statement
RELEASE statement
RELEASE SAVEPOINT statement
RENAME statement
REVOKE statement
ROLLBACK statement
SAVEPOINT statement
SELECT INTO statement
SET CONNECTION statement
SET special-register statement
TRUNCATE statement
UPDATE statement
VALUES INTO statement

1 2

Notes:

¹ An ALTER FUNCTION (SQL scalar) statement or an ALTER PROCEDURE (SQL native) statement with an ADD VERSION or REPLACE clause is not allowed in an *SQL-routine-body*.

² The COMMIT statement and the ROLLBACK statement (without the TO SAVEPOINT clause) must not be issued in a routine body if the routine is in the calling chain of an SQL routine, an external routine, or a trigger.

Description for ALTER PROCEDURE (SQL - native)

procedure-name

Identifies the procedure to alter. The procedure that is identified in *procedure-name* must exist at the current server.

The procedure must not be obfuscated.

ACTIVE VERSION or ALL VERSIONS or VERSION *routine-version-id*

Identifies the version of the procedure that is to be changed, replaced, or regenerated depending on whether the ALTER, REPLACE, or REGENERATE keyword is specified.

Important: Do not create additional versions of procedures that are supplied with Db2 by specifying the VERSION keyword. Only versions that are supplied with Db2 are supported. Additional versions of such routines cause the installation and configuration of the supplied routines to fail.

ACTIVE VERSION

Specifies that the currently active version of the procedure is to be changed, replaced, or regenerated.

ACTIVE VERSION is the default value.

ALL VERSIONS

Specifies that all of the versions of the procedure are to be changed. Only the following options can be changed when this option is specified:

- AUTONOMOUS or COMMIT ON RETURN

VERSION *routine-version-id*

Identifies the version of the procedure that is to be changed, replaced, or regenerated. *routine-version-id* is the version identifier that is assigned when the version is defined. *routine-version-id* must identify a version of the specified procedure that exists at the current server.

ALTER

Specifies that a version of the procedure is to be changed.

When you change a procedure to add or replace a version of the procedure, any option that is not explicitly specified will use the existing value from the version of the procedure that is being changed.

REPLACE

Specifies that a version of the procedure is to be replaced.

Binding the replaced version of the procedure might result in a new access path even if the routine body is not changed.

When you replace a procedure, the data types, CCSID specifications, and character data attributes (FOR BIT/SBCS/MIXED DATA) of the parameters must be the same as the attributes of the corresponding parameters for the currently active version of the procedure. For options that are not explicitly specified, the system default values for those options are used, even if those options were explicitly specified for the version of the procedure that is being replaced. This is not the case for versions of the procedure that specified DISABLE DEBUG MODE. If DISABLE DEBUG MODE is specified for a version of a procedure, it cannot be changed by the REPLACE clause. When a procedure definition is replaced, any existing comments in the catalog for that definition of the procedure are removed.

ADD VERSION *routine-version-id*

Specifies that a new version of the procedure is to be created. *routine-version-id* is the version identifier for the new version of the procedure. *routine-version-id* must not identify a version of the specified procedure that already exists at the current server.

When you add a new version of a procedure the data types, CCSID specifications, and character data attributes (FOR BIT/SBCS/MIXED DATA) of the parameters must be the same as the attributes of the corresponding parameters for the currently active version of the procedure. The parameter names can differ from the other versions of the procedure. For options that are not explicitly specified, the system default values will be used.

ACTIVATE VERSION *routine-version-id*

Specifies the version of the procedure that is to be the currently active version of the procedure. *routine-version-id* is the version identifier that is assigned when the version of the procedure is defined. The version that is specified with *routine-version-id* is the version that will be invoked by the CALL statement, unless the value of the CURRENT ROUTINE VERSION special register overrides the currently active version of the procedure when the procedure is invoked. *routine-version-id* must identify a version of the procedure that already exists at the current server.

REGENERATE

Regenerates a version of the procedure. When Db2 maintenance is applied that changes how an SQL procedure is generated, the procedure might need to be regenerated to process the maintenance changes.

REGENERATE automatically rebinds, at the local server, the package for the SQL control statements for the procedure and rebinds the package for the SQL statements that are included in the procedure body. If a remote bind is also needed, the BIND PACKAGE COPY command must be explicitly done for all of the remote servers.

REGENERATE is different from a REBIND PACKAGE command where the SQL statements are rebound (i.e. to generate better access paths for those statements), but the SQL control statements in the procedure definition remain the same.

USING APPLICATION COMPATIBILITY *applcompat-level*

Specifies the application compatibility level used to regenerate the version of the procedure. The ALTER statement returns an error if the existing definition of the version includes syntax, semantics, or options that require a higher application compatibility level. This situation can occur when the version was most recently defined or regenerated while running at a higher application compatibility level than *applcompat-level*.

The following values can be specified:

VvvRrMmmm

Compatibility with the behavior of the identified Db2 function level. For example, V12R1M510 specifies compatibility with the highest available Db2 12 function level. The equivalent function level or higher must be activated.

For the new capabilities that become available in each application compatibility level, see:

- [SQL changes in Db2 13 application compatibility levels](#)
- [SQL changes in Db2 12 application compatibility levels](#)

Tip: Extra program preparation steps might be required to increase the application compatibility level for applications that use data server clients or drivers to access Db2 for z/OS. For more information, see [Setting application compatibility levels for data server clients and drivers \(Db2 Application programming and SQL\)](#).

V12R1

Compatibility with the behavior of Db2 12 function level 500. This value has the same result as specifying V12R1M500.

V11R1

Compatibility with the behavior of Db2 11 new-function mode. After migration to Db2 12, this value has the same result as specifying V12R1M100. For more information, see [V11R1 application compatibility level \(Db2 Application programming and SQL\)](#)

V10R1

Compatibility with the behavior of DB2 10 new-function mode. For more information, see [V10R1 application compatibility level \(Db2 Application programming and SQL\)](#).

If USING APPLICATION COMPATIBILITY is omitted, the regeneration uses the APPLCOMPAT value of the applicable SYSIBM.SYSPACKAGE catalog table row.

DROP VERSION *routine-version-id*

Drops the version of the procedure that is identified with *routine-version-id*. *routine-version-id* is the version identifier that is assigned when the version is defined. *routine-version-id* must identify a version of the procedure that already exists at the current server and must not identify the currently active version of the procedure. Only the identified version of the procedure is dropped.

When only a single version of the procedure exists at the current server, use the DROP PROCEDURE statement to drop the procedure. A version of the procedure for which the version identifier is the same as the contents of the CURRENT ROUTINE VERSION special register can be dropped if that version is not the currently active version of the procedure.

(*parameter-declaration,...*)

Specifies the number of parameters of the procedure, the data type and usage of each parameter, and the name of each parameter for the version of the procedure that is being defined or changed. The number of parameters and the specified data type and usage of each parameter must match the data types in the corresponding position of the parameter for all other versions of this procedure. Synonyms for data types are considered to be a match.

IN, OUT, and INOUT specify the usage of the parameter. The usage of the parameters must match the implicit or explicit usage of the parameters of other versions of the same procedure.

IN

Identifies the parameter as an input parameter to the procedure. The value of the parameter on entry to the procedure is the value that is returned to the calling SQL application, even if changes are made to the parameter within the procedure.

IN is the default.

OUT

Identifies the parameter as an output parameter that is returned by the procedure. If the parameter is not set within the procedure, the null value is returned.

INOUT

Identifies the parameter as both an input and output parameter for the procedure. If the parameter is not set within the procedure, its input value is returned.

parameter-name

Names the parameter for use as an SQL variable. The name cannot be the same as the name of any other *parameter-name* for this version of the procedure. The name of the parameter in this version of the procedure can be different than the name of the corresponding parameter for other versions of this procedure.

built-in-type

Specifies the data type of the parameter. See [“CREATE PROCEDURE statement \(SQL - native procedure\)”](#) on page 1607 for more information on data type specifications.

distinct-type-name

The data type of the input parameter is a distinct type. Any length, precision, scale, subtype, or encoding scheme attributes for the parameter are those of the source type of the distinct type. The distinct type must not be based on a LOB data type.

array-type-name

The data type of the input parameter is a user-defined array type.

If you specify *array-type-name* without a schema name, Db2 resolves the array type by searching the schemas in the SQL path.

NOT DETERMINISTIC or DETERMINISTIC

Specifies whether the procedure returns the same results each time it is called with the same IN and INOUT arguments.

NOT DETERMINISTIC

The procedure might not return the same result each time it is called with the same IN and INOUT arguments, even when the data that is referenced in the database has not changed.

NOT DETERMINISTIC is the default.

DETERMINISTIC

The procedure always returns the same results each time it is called with the same IN and INOUT arguments if the data that is referenced in the database has not changed.

Db2 does not verify that the procedure code is consistent with the specification of DETERMINISTIC or NOT DETERMINISTIC.

MODIFIES SQL DATA, READS SQL DATA, or CONTAINS SQL

Specifies the classification of SQL statements and nested routines that this routine can execute or invoke. The database manager verifies that the SQL statements issued by the procedure, and all routines locally invoked by the routine, are consistent with this specification; the verification is not performed when nested remote routines are invoked. For the classification of each statement, see [Appendix D, “SQL statement data access classification for routines,”](#) on page 2275.

MODIFIES SQL DATA

Specifies that the procedure can execute any SQL statement except statements that are not supported in procedures.

MODIFIES SQL DATA is the default.

READS SQL DATA

Specifies that procedure can execute statements with a data access indication of READS SQL DATA or CONTAINS SQL. The procedure cannot execute SQL statements that modify data.

CONTAINS SQL

Specifies that the procedure can execute only SQL statements with an access indication of CONTAINS SQL. The procedure cannot execute statements that read or modify data.

CALLED ON NULL INPUT

Specifies that the procedure will be called if any, or even if all parameter values are null.

DYNAMIC RESULT SETS *integer*

Specifies the maximum number of query result sets that the procedure can return. The default is DYNAMIC RESULT SETS 0, which indicates that there are no result sets. The value must be in the range 0–32767.

ALLOW DEBUG MODE, DISALLOW DEBUG MODE, or DISABLE DEBUG MODE

Specifies whether the version of the procedure can be run in debugging mode. The default for a new version of a procedure is determined using the value of the CURRENT DEBUG MODE special register.

ALLOW DEBUG MODE

Specifies that this version of the procedure can be run in debugging mode. When this version of the procedure is invoked and debugging is attempted, a WLM environment must be available.

DISALLOW DEBUG MODE

Specifies that the version of the procedure cannot be run in debugging mode.

You can use a subsequent ALTER PROCEDURE statement to change this option to ALLOW DEBUG MODE.

DISABLE DEBUG MODE

Specifies that the version of the procedure can never be run in debugging mode.

The version of the procedure cannot be changed to specify ALLOW DEBUG MODE or DISALLOW DEBUG MODE after the version of the procedure has been created, replaced, or altered to use DISABLE DEBUG MODE. To change DEBUG MODE for a version of a procedure that specifies

DISABLE DEBUG MODE, you must drop and re-create the version of the procedure using the option that you want.

When DISABLE DEBUG MODE is in effect, the WLM ENVIRONMENT FOR DEBUG MODE option is ignored.

PARAMETER CCSID

Indicates whether the encoding scheme for character or graphic string parameters is ASCII, EBCDIC, or UNICODE. The default encoding scheme is the value that is specified in the CCSID clauses of the parameter list or in the field DEF ENCODING SCHEME on installation panel DSNTIPF.

This clause provides a convenient way to specify the encoding scheme for character or graphic string parameters. If individual CCSID clauses are specified for individual parameters in addition to this PARAMETER CCSID clause, the value that is specified in all of the CCSID clauses must be the same value that is specified in this clause.

If the data type for a parameter is a user-defined distinct type that is defined as a character or graphic type string, the CCSID of the distinct type must be the same as the value that is specified in this clause.

If the data type for a parameter is a user-defined array type that is defined with character or graphic string array elements, or a character string array index, the CCSID of these array attributes must be the same as the value that is specified in this clause.

This clause also specifies the encoding scheme that will be used for system-generated parameters of the routine.

QUALIFIER *schema-name*

Specifies the implicit qualifier that is used for unqualified object names that are referenced in the procedure body. For information about how the default for this option is determined, see [“Unqualified alias, index, JAR file, mask, permission, sequence, table, trigger, and view names” on page 86](#).

PACKAGE OWNER *authorization-name*

Specifies the owner of the package that is associated with the version of the procedure. The SQL authorization ID of the process is the default value.

This authorization ID must have the privileges required to execute the SQL statements that are contained in the body of the routine and must contain the necessary bind privileges. The value of the PACKAGE OWNER option is subject to translation when sent to a remote system.

Refer to the **Authorization** section of the [BIND PACKAGE subcommand \(DSN\) \(Db2 Commands\)](#) command for authorization requirements.

ASUTIME

Specifies the total amount of processor time, in CPU service units, that a single invocation of a procedure can run. The value is unrelated to the ASUTIME column of the resource limit specification table.

When you are debugging a procedure, setting a limit can be helpful in case the procedure gets caught in a loop. For information on service units, see [z/OS MVS Initialization and Tuning Guide](#).

NO LIMIT

Specifies that there is no limit on the number of CPU service units that the procedure can run.

NO LIMIT is the default.

LIMIT *integer*

The limit on the number of CPU service units is a positive *integer* in the range 1 - 2147483647.

If the procedure uses more service units than the specified value, Db2 cancels the procedure.

The CPU cycles that are consumed by parallel tasks in a procedure do not contribute towards the specified ASUTIME LIMIT.

COMMIT ON RETURN NO, COMMIT ON RETURN YES, or AUTONOMOUS

Indicates whether Db2 commits the transaction immediately on return from the procedure.

COMMIT ON RETURN NO

Db2 does not issue a commit when the procedure returns. NO is the default.

COMMIT ON RETURN YES,

Db2 issues a commit when the procedure returns if the following statements are true:

- The SQLCODE that is returned by the CALL statement is not negative.
- The procedure is not in a must-abort state.

The commit operation includes the work that is performed by the calling application process and by the procedure.

If the procedure returns result sets, the cursors that are associated with the result sets must have been defined as WITH HOLD to be usable after the commit.

AUTONOMOUS

Db2 executes the SQL procedure in a unit of work that is independent from the calling application. When this option is specified the procedure follows the rules of the COMMIT ON RETURN YES option before returning to the calling application. However, it does not commit changes in the calling application. When autonomous is specified:

- DYNAMIC RESULT SETS 0 must be in effect.
- Stored procedure parameters must not be defined as:
 - A LOB type
 - The XML data type
 - A distinct data type that is based on a LOB or XML value
 - An array type that is defined with array elements that are a LOB type

A value must not be assigned to a global variable when an autonomous procedure is executing.

INHERIT SPECIAL REGISTERS or DEFAULT SPECIAL REGISTERS

Specifies how special registers are set on entry to the routine.

INHERIT SPECIAL REGISTERS

Specifies that the values of special registers are inherited, according to the rules that are listed in the table for characteristics of special registers in a procedure in [“Special registers in a user-defined function or a stored procedure”](#) on page 215.

INHERIT SPECIAL REGISTERS is the default.

DEFAULT SPECIAL REGISTERS

Specifies that special registers are initialized to the default values, as indicated by the rules in the table for characteristics of special registers in a procedure in [“Special registers in a user-defined function or a stored procedure”](#) on page 215.

WLM ENVIRONMENT FOR DEBUG MODE *name*

Specifies the WLM (workload manager) application environment used by Db2 when debugging the procedure. The *name* of the WLM environment is an SQL identifier.

If you do not specify WLM ENVIRONMENT FOR DEBUG MODE, Db2 uses the default WLM-established stored procedure address space that is specified at installation time.

The WLM ENVIRONMENT FOR DEBUG MODE value is ignored when DISABLE DEBUG MODE is in effect.

You must have the appropriate authority for the WLM application environment.

DEFER PREPARE or NODEFER PREPARE

Specifies whether to defer preparation of dynamic SQL statements that refer to remote objects, or to prepare them immediately.

The default depends on the value that is specified for the REOPT option. If REOPT NONE is specified, the default is NODEFER PREPARE. Otherwise, the default is DEFER PREPARE.

DEFER PREPARE

Specifies that the preparation of dynamic SQL statements that refer to remote objects will be deferred.

For considerations with distributed processing, see [DEFER and NODEFER bind options \(Db2 Commands\)](#).

NODEFER PREPARE

Specifies that the preparation of dynamic SQL statements that refer to remote objects will not be deferred.

CURRENT DATA

Specifies whether to require data currency for read-only and ambiguous cursors when the isolation level of cursor stability is in effect. CURRENT DATA also determines whether block fetch can be used for distributed, ambiguous cursors. For more information about updating the current row of a cursor, block fetch, and data currency, see [Choosing a CURRENTDATA option \(Db2 Performance\)](#).

YES

Specifies that data currency is required for read-only and ambiguous cursors. Db2 acquires page or row locks to ensure data currency. Block fetch is not allowed for distributed, ambiguous cursors.

NO

Specifies that data currency is not required for read-only and ambiguous cursors. Block fetch is allowed for distributed, ambiguous cursors. Use of CURRENT DATA(NO) is not recommended if the procedure attempts to dynamically prepare and execute a DELETE WHERE CURRENT OF statement against an ambiguous cursor after that cursor is opened. You receive a negative SQLCODE if your procedure attempts to use a DELETE WHERE CURRENT OF statement for any of the following cursors:

- A cursor that is using block fetch
- A cursor that is using query parallelism
- A cursor that is positioned on a row that is modified by this or another application process

No is the default.

DEGREE

Specifies whether to attempt to run a query using parallel processing to maximize performance.

1

Specifies that parallel processing should not be used.

1 is the default.

ANY

Specifies that parallel processing can be used.

CONCURRENT ACCESS RESOLUTION

Specifies the whether processing uses only committed data or whether it will wait for commit or rollback of data that is in the process of being updated.

WAIT FOR OUTCOME

Specifies that processing will wait for the commit or rollback of data that is in the process of being updated.

USE CURRENTLY COMMITTED

Specifies that processing use the currently committed version of the data when data that is in the process of being updated is encountered. USE CURRENTLY COMMITTED is applicable on scans that access tables that are defined in universal table spaces with row or page level lock size.

When there is lock contention between a read transaction and an insert transaction, USE CURRENTLY COMMITTED is applicable to scans with isolation level CS or RS. Applicable scans include intent read scans for read-only and ambiguous queries and for updatable cursors. USE CURRENTLY COMMITTED is also applicable to scans initiated from WHERE predicates of UPDATE or DELETE statements and the subselect of INSERT statements.

When there is lock contention is between a read transaction and a delete transaction, USE CURRENTLY COMMITTED is applicable to scans with isolation level CS and when CURRENT DATA NO is specified.

DYNAMICRULES

Specifies the values that apply, at run time, for the following dynamic SQL attributes:

- The authorization ID that is used to check authorization
- The qualifier that is used for unqualified objects
- The source for application programming options that Db2 uses to parse and semantically verify dynamic SQL statements

DYNAMICRULES also specifies whether dynamic SQL statements can include GRANT, REVOKE, ALTER, CREATE, DROP, and RENAME statements.

In addition to the value of the DYNAMICRULES clause, the run time environment of a native SQL procedure controls how dynamic SQL statements behave at run time. The combination of the DYNAMICRULES value and the run time environment determines the value for the dynamic SQL attributes. That set of attribute values is called the dynamic SQL statement behavior. The following values can be specified:

RUN

Specifies that dynamic SQL statements are to be processed using run behavior.

RUN is the default.

BIND

Specifies that dynamic SQL statements are to be processed using bind behavior.

DEFINEBIND

Specifies that dynamic SQL statements are to be processed using either define behavior or bind behavior.

DEFINERUN

Specifies that dynamic SQL statements are to be processed using either define behavior or run behavior.

INVOKEBIND

Specifies that dynamic SQL statements are to be processed using either invoke behavior or bind behavior.

INVOKERUN

Specifies that dynamic SQL statements are to be processed using either invoke behavior or run behavior.

See “Authorization IDs and [dynamic SQL](#)” on page 94 for information on the effects of these options.

APPLICATION ENCODING SCHEME

Specifies the default encoding scheme for SQL variables in static SQL statements in the procedure body. The value is used for defining an SQL variable in a compound statement if the CCSID clause is not specified as part of the data type, and the PARAMETER CCSID routine option is not specified.

ASCII

Specifies that the data is encoded using the ASCII CCSIDs of the server.

EBCDIC

Specifies that the data is encoded using the EBCDIC CCSIDs of the server.

UNICODE

Specifies that the data is encoded using the Unicode CCSIDs of the server.

For information about how the default for this option is determined, see [ENCODING bind option \(Db2 Commands\)](#).

WITH EXPLAIN or WITHOUT EXPLAIN

Specifies whether information will be provided about how SQL statements in the procedure will execute.

WITHOUT EXPLAIN

Specifies that information will not be provided about how SQL statements in the procedure will execute.

You can get EXPLAIN output for a statement that is embedded in a native SQL procedure that is specified using WITHOUT EXPLAIN by embedding the SQL statement EXPLAIN in the procedure body. Otherwise, the value of the EXPLAIN option applies to all explainable SQL statements in the procedure body, and to the fullselect portion of any DECLARE CURSOR statements.

WITHOUT EXPLAIN is the default.

WITH EXPLAIN

Specifies that information will be provided about how SQL statements in the procedure will execute. Information is inserted into the table *owner*.PLAN_TABLE. *owner* is the authorization ID of the owner of the procedure package. Alternatively, the authorization ID of the owner of the procedure can have an alias as *owner*.PLAN_TABLE that points to the base table, PLAN_TABLE. *owner* must also have the appropriate SELECT and INSERT privileges on that table. WITH EXPLAIN does not obtain information for statements that access remote objects. PLAN_TABLE must have a base table and can have multiple aliases with the same table name, PLAN_TABLE, but have different schema qualifiers; it cannot be a view or a synonym. It should exist before the version is added or replaced. In all inserts to *owner*.PLAN_TABLE, the value of QUERYNO is the statement number that is assigned by Db2.

The WITH EXPLAIN option also populates two optional tables, if they exist: DSN_STATEMNT_TABLE and DSN_FUNCTION_TABLE. DSN_STATEMNT_TABLE contains an estimate of the processing cost for an SQL statement.

For more information about the EXPLAIN statement, including a description of the tables that are populated by the WITH EXPLAIN option, see [“EXPLAIN statement” on page 1917](#).

WITH IMMEDIATE WRITE or WITHOUT IMMEDIATE WRITE

Specifies whether immediate writes are to be done for updates that are made to group buffer pool dependent page sets or partitions. This option is only applicable for data sharing environments. The IMMEDWRITE subsystem parameter has no affect of this option. [IMMEDWRITE bind option \(Db2 Commands\)](#) shows the implied hierarchy of the IMMEDWRITE bind option (which is similar to this procedure option) as it affects run time.

WITHOUT IMMEDIATE WRITE

Specifies that normal write activity is performed. Updated pages that are group buffer pool dependent are written at or before phase one of commit or at the end of abort for transactions that have been rolled back.

WITHOUT IMMEDIATE WRITE is the default.

WITH IMMEDIATE WRITE

Specifies that updated pages that are group buffer pool dependent are immediately written as soon as the buffer update completes. Updated pages are written immediately even if the buffer is updated during forward progress or during the rollback of a transaction. WITH IMMEDIATE WRITE might impact performance.

ISOLATION LEVEL RR, RS, CS, or UR

Specifies how far to isolate the procedure from the effects of other running applications. For information about isolation levels, see [Choosing a RELEASE option \(Db2 Performance\)](#).

RR

Specifies repeatable read.

RS

Specifies read stability.

CS

Specifies cursor stability. CS is the default.

UR

Specifies uncommitted read.

WITH KEEP DYNAMIC or WITHOUT KEEP DYNAMIC

Specifies whether Db2 keeps dynamic SQL statements after commit points.

WITHOUT KEEP DYNAMIC

Specifies that Db2 does not keep dynamic SQL statements after commit points.

WITHOUT KEEP DYNAMIC is the default.

WITH KEEP DYNAMIC

Specifies that Db2 keeps dynamic SQL statements after commit points. If you specify WITH KEEP DYNAMIC, the application does not need to prepare an SQL statement after every commit point. Db2 keeps the dynamic SQL statement until one of the following occurs:

- The application process ends
- A rollback operations occurs
- The application executes an explicit PREPARE statement with the same statement identifier as the dynamic SQL statement

If you specify WITH KEEP DYNAMIC, and the dynamic statement cache is active, the Db2 subsystem keeps a copy of the prepared statement in the cache. If the dynamic statement cache is not active, the subsystem keeps only the SQL statement string past a commit point. If the application executes an OPEN, EXECUTE, or DESCRIBE operation for that statement, the statement is implicitly prepared.

If you specify WITH KEEP DYNAMIC, DDF server threads that are used to execute procedures or packages that have this option in effect will remain active. Active DDF server threads are subject to idle thread time outs. For more information, see [IDLE THREAD TIMEOUT field \(IDTHTOIN subsystem parameter\) \(Db2 Installation and Migration\)](#).

If you specify WITH KEEP DYNAMIC, you must not specify REOPT ALWAYS. WITH KEEP DYNAMIC and REOPT ALWAYS are mutually exclusive. However, you can specify WITH KEEP DYNAMIC and REOPT ONCE.

Use WITH KEEP DYNAMIC to improve performance if your DRDA client application uses a cursor that is defined as WITH HOLD. The Db2 subsystem automatically closes a held cursor when there are no more rows to retrieve, which eliminates an extra network message.

OPTHINT *string-constant*

Specifies whether query optimization hints are used for static SQL statements that are contained within the body of the procedure.

string-constant is a character string of up to 128 bytes in length, which is used by the Db2 subsystem when searching the PLAN_TABLE for rows to use as input. The default value is an empty string, which indicates that the Db2 subsystem does not use optimization hints for static SQL statements.

Optimization hints are only used if optimization hints are enabled for you system. For more information, see [OPTIMIZATION HINTS field \(OPTHINTS subsystem parameter\) \(Db2 Installation and Migration\)](#)

SQL PATH

Specifies the SQL path that the Db2 subsystem uses to resolve unqualified user-defined types, functions, and procedure names (in CALL statements) in the body of the procedure. The default value is "SYSIBM", "SYSFUN", "SYSPROC", "SYSIBMADM", and the value of the QUALIFIER option.

The maximum length of the SQL path is 2048 bytes. Db2 calculates the length by taking each *schema-name* specified and removing any trailing blanks from it, adding two delimiters around it, and adding one comma after each schema name except for the last one. The length of the resulting string cannot exceed 2048 bytes.

schema-name

Specifies a schema. Db2 does not validate that the specified schema actually exists when the ALTER statement is processed.

SYSPUBLIC must not be specified for the SQL path.

schema-name-list

Specifies a comma separated list of schema names. The same schema name should not appear more than one time in the list of schema names. The number of schema names that you can specify is limited by the maximum length of the resulting SQL path.

SYSPUBLIC must not be specified for the SQL path.

SYSTEM PATH

Specifies the schema names "SYSIBM", "SYSFUN", "SYSPROC", "SYSIBMADM".

SESSION_USER or USER

Specifies the value of the SESSION_USER (or USER) special register. At the time the ALTER statement is processed, the actual length is included in the total length of the list of schema names that is specified for the PATH option. If you specify SESSION_USER (or USER) in a list of schema names, do not use delimiters around the SESSION_USER (or USER) keyword.

RELEASE AT

Specifies when to release resources that the procedure uses: either at each commit point or when the procedure terminates.

COMMIT

Specifies that resources will be released at each commit point.

COMMIT is the default.

DEALLOCATE

Specifies that resources will be released only when the procedure terminates. DEALLOCATE has no effect on packages that run on a Db2 server through a DRDA connection with a client system. DEALLOCATE also has no effect on dynamic SQL statements, which always use RELEASE AT COMMIT, with this exception: When you use the RELEASE AT DEALLOCATE clause and the WITH KEEP DYNAMIC clause, and the subsystem is installed with a value of YES for the field CACHE DYNAMIC SQL on installation panel DSNTIP8, the RELEASE AT DEALLOCATE option is honored for dynamic SELECT and SQL data change statements.

Locks that are acquired for dynamic statements are held until one of the following events occurs:

- The application process ends.
- The application process issues a PREPARE statement with the same statement identifier. (Locks are released at the next commit point).
- The statement is removed from the dynamic statement cache because the statement has not been used. (Locks are released at the next commit point).
- An object that the statement is dependent on is dropped or altered, or a privilege that the statement needs is revoked. (Locks are released at the next commit point).

RELEASE AT DEALLOCATE can increase the package size because additional items become resident in the package.

For more information about how the RELEASE clause affects locking and concurrency, see [Choosing a RELEASE option \(Db2 Performance\)](#).

QUERY ACCELERATION

Specifies whether a static SQL query is bound for acceleration, and if so, with what behavior.

NONE

Specifies that no static SQL query in the application is bound for acceleration or will be accelerated when the application is run.

ENABLE

Specifies that a static SQL query is bound for acceleration if it satisfies the acceleration criteria, including the cost and heuristics criteria. The query is routed to an accelerator when the application runs. Otherwise, if the static query does not satisfy the acceleration criteria, the query is bound for execution in Db2.

If an error condition, such as one of the following examples, occurs while executing the accelerated static query when the application is run, Db2 fails the static query and returns a negative SQL code to the application:

- A failure occurs while running the static query on the accelerator.
- The accelerator returns an error for the query.
- The accelerator is not started and Db2 cannot route the static query to the accelerator for execution.

ENABLE WITH FAILBACK

Results in the same behavior as **ENABLE**, except if one of the error conditions occurs on the first **OPEN** of the accelerated static query when the application is run. In this case, instead of failing the static query and returning a negative SQL code to the application, Db2 performs a temporary *statement-level* incremental bind of the query and runs the query in Db2. The application does not see the acceleration failure. Failback to Db2 is not possible after the application does a successful **OPEN** for the query on the accelerator.

ELIGIBLE

Specifies that a static SQL query is bound for acceleration if the query meets the basic acceleration criteria, regardless of the cost or heuristics criteria. The query is routed to the accelerator when the application runs.

Like the behavior for **ENABLE**, if an error condition occurs while executing the accelerated static query when the application is run, Db2 fails the static query and returns a negative SQL code to the application.

ALL

Specifies that all of the static SQL queries in the application are to be bound for acceleration and routed to the accelerator when the application runs. If Db2 determines that a static query cannot be bound to run on the accelerator and the query references a user base table or view, the **BIND** or **REBIND PACKAGE** operation fails with an error message for that query. (A failure exception is made for declared global temporary tables (DGTTs) and created global temporary tables and (CGTTs) because these tables cannot be accelerated.)

Like the behavior for **ENABLE**, if an error condition occurs while executing the accelerated static query when the application is run, Db2 fails the static query and returns a negative SQL code to the application.

This bind option does not apply to a *fullselect* or *WITH common-table-expression* that is specified in a **RETURN** statement for the routine, or in a **SET host-variable-assignment** that is used in the routine. The queries that are specified in these cases cannot be accelerated.

GET_ACCEL_ARCHIVE

Specifies whether a static SQL query that is bound for acceleration retrieves archived data on the accelerator, instead of active data.

NO

Specifies that no static SQL query is bound to retrieve archived data from the accelerator. If the static query also is not bound for acceleration, the query is bound to run in Db2.

If the static query is bound for acceleration because the **QUERYACCELERATION** bind option was specified, the query is routed to the accelerator when the application runs; however, the query does not retrieve any archived data.

YES

Specifies that if all of the following criteria are met, the query is bound for acceleration and retrieves the archived data on the accelerator when the application runs:

- The **QUERYACCELERATION** bind option is also specified.
- The static SQL query references an accelerated table that has partitioned data archived on an accelerator.

- The static query satisfies the acceleration criteria that is specified by the QUERYACCELERATION bind option.

If the static query does not satisfy the acceleration criteria that is specified by the QUERYACCELERATION bind option, the BIND or REBIND PACKAGE operation fails with an error message for that query.

This bind option does not apply to a *fullselect* or *WITH common-table-expression* that is specified in a RETURN statement for the routine, or in a SET *host-variable-assignment* that is used in the routine. The queries that are specified in these cases cannot be accelerated.

ACCELERATION WAITFORDATA

Specifies the maximum amount of time, if any, that an accelerator will delay a query while the accelerator waits for the replication of committed Db2 data changes that occurred prior to Db2 running the query.

For static accelerated queries, you must also set the QUERYACCELERATION bind option for this function or procedure to a valid value other than NONE to request that static queries be accelerated. If the QUERYACCELERATION bind option value is set to NONE, the ACCELERATIONWAITFORDATA bind option is accepted and the package is bound with the option value; however, the option will not apply to static SQL queries because no static queries will be accelerated.

For dynamic accelerated queries, specifying the ACCELERATION WAITFORDATA bind option also initializes the CURRENT QUERY ACCELERATION WAITFORDATA special register, which is used for the dynamic queries in the Db2 function or procedure if the function or procedure option DEFAULT SPECIAL REGISTERS is also used. Initializing CURRENT QUERY ACCELERATION WAITFORDATA to a value greater than 0 specifies that Db2 and the accelerator will apply WAITFORDATA delay behavior and restrictions to all dynamic SQL queries to be accelerated from the Db2 function or procedure. The CURRENT QUERY ACCELERATION special register must also have a valid value other than NONE to request that dynamic queries be accelerated.

nnnn.m

Specifies a DECIMAL(5,1) numeric-constant value that specifies the maximum number of seconds that the accelerator will delay a query while the accelerator waits for the replication of committed Db2 data changes that occurred prior to Db2 running the query.

You can specify a value in the range of 0.0–3600.0 seconds. For example, a value of 20.0 represents 20.0 seconds (or 20000 milliseconds), and a value of 30.5 represents 30.5 seconds (or 30500 milliseconds). The maximum value of 3600.0 means they the query is delayed for 3600 seconds.

You can also specify the value as an INTEGER numeric-constant value ranging 0–3600 seconds, which Db2 will convert to a DECIMAL(5,1) value.

Important: When a non-zero value is specified for the ACCELERATIONWAITFORDATA bind option, Db2 and the accelerator will apply other WAITFORDATA delay behaviors, restrictions, and requirements to all queries that will be accelerated from the application package. These behaviors, restrictions, and requirements can cause queries that were formerly accelerated successfully to no longer be accelerated or to fail. See [“SET CURRENT QUERY ACCELERATION WAITFORDATA statement” on page 2150](#) for more information about WAITFORDATA behaviors, restrictions, and requirements.

ACCELERATOR

Specifies an accelerator server that, if enabled and available, Db2 will consider as the preferred accelerator for eligible SQL queries before sending the queries to other accelerator servers. If the specified accelerator server is not enabled or available, Db2 will send the queries to other available accelerator servers.

REOPT

Specifies if Db2 will determine the access path at run time by using the values of SQL variables or SQL parameters, parameter markers, and special registers.

NONE

Specifies that Db2 does not determine the access path at run time by using the values of SQL variables or SQL parameters, parameter markers, and special registers.

NONE is the default.

ALWAYS

Specifies that Db2 always determine the access path at run time each time an SQL statement is run.

ONCE

Specifies that Db2 determine the access path for any dynamic SQL statements only one time, at the first time the statement is opened. This access path is used until the prepared statement is invalidated or removed from the dynamic statement cache and needs to be prepared again.

VALIDATE RUN or VALIDATE BIND

Specifies whether to recheck, at run time, errors of the type "OBJECT not FOUND" and NOT AUTHORIZED" that are found during bind or rebind. The option has no effect if all objects and needed privileges exist.

VALIDATE RUN

Specifies that if needed objects or privileges do not exist when the ALTER PROCEDURE statement is processed, warning messages are returned, but the ALTER PROCEDURE statement succeeds. The Db2 subsystem rechecks for the objects and privileges at run time for those SQL statements that failed the checks during processing of the ALTER PROCEDURE statement. The authorization checks the use of the authorization ID of the owner of the procedure package.

VALIDATE RUN is the default.

VALIDATE BIND

Specifies that if needed objects or privileges do not exist at the time the ALTER PROCEDURE statement is processed, an error is issued and the ALTER PROCEDURE statement fails.

ROUNDING

Specifies the rounding mode for manipulation of DECFLOAT data.

DEC_ROUND_CEILING

Specifies numbers are rounded towards positive infinity.

DEC_ROUND_DOWN

Specifies numbers are rounded towards 0 (truncation).

DEC_ROUND_FLOOR

Specifies numbers are rounded towards negative infinity.

DEC_ROUND_HALF_DOWN

Specifies numbers are rounded to nearest; if equidistant, round down.

DEC_ROUND_HALF_EVEN

Specifies numbers are rounded to nearest; if equidistant, round so that the final digit is even.

DEC_ROUND_HALF_UP

Specifies numbers are rounded to nearest; if equidistant, round up.

DEC_ROUND_UP

Specifies numbers are rounded away from 0.

DATE FORMAT ISO, EUR, USA, JIS, or LOCAL

Specifies the date format for result values that are string representations of date or time values. See [“String representations of datetime values” on page 120](#) for more information.

The default format is specified in the DATE FORMAT field of installation panel DSNTIP4 of the system where the procedure is defined. You cannot use the LOCAL option unless you have a date exit routine.

DECIMAL(15), DECIMAL(31), DECIMAL(15,s), or DECIMAL(31,s)

Specifies the maximum precision that is to be used for decimal arithmetic operations. For more information, see [“Arithmetic with two decimal operands” on page 251](#). The default format is specified in the DECIMAL ARITHMETIC field of installation panel DSNTIPF of the system where the procedure is

defined. If the form *pp.s* is specified, *s* must be a number in the range 1–9. *s* represents the minimum scale that is to be used for division.

FOR UPDATE CLAUSE OPTIONAL or FOR UPDATE CLAUSE REQUIRED

Specifies whether the FOR UPDATE clause is required for a DECLARE CURSOR statement if the cursor is to be used to perform positioned updates.

FOR UPDATE CLAUSE REQUIRED

Specifies that a FOR UPDATE clause must be specified as part of the cursor definition if the cursor will be used to make positioned updates.

FOR UPDATE CLAUSE REQUIRED is the default.

FOR UPDATE CLAUSE OPTIONAL

Specifies that the FOR UPDATE clause does not need to be specified in order for a cursor to be used for positioned updates. The procedure body can include positioned UPDATE statements that update columns that the user is authorized to update.

If the resulting DBRM for the procedure is very large, you might need extra storage when you specify FOR UPDATE CLAUSE OPTIONAL.

The FOR UPDATE clause of the select-statement with no column list applies to static or dynamic SQL statements. You can specify the FOR UPDATE OF clause of the select-statement with a column list to restrict updates to only the columns that are named in the column list and to specify the acquisition of update locks.

TIME FORMAT ISO, EUR, USA, JIS, or LOCAL

Specifies the time format for result values that are string representations of date or time values. See [“String representations of datetime values”](#) on page 120 for more information.

The default format is specified in the TIME FORMAT field of installation panel DSNTIP4 of the system where the procedure is defined. You cannot use the LOCAL option unless you have a date exit routine.

BUSINESS_TIME SENSITIVE

Determines whether references to application-period temporal tables in both static and dynamic SQL statements are affected by the value of the CURRENT TEMPORAL BUSINESS_TIME special register.

YES

References to application-period temporal tables are affected by the value of the CURRENT TEMPORAL BUSINESS_TIME special register. YES is the default value.

NO

References to application-period temporal tables are not affected by the value of the CURRENT TEMPORAL BUSINESS_TIME special register.

For more information, see [“CURRENT TEMPORAL BUSINESS_TIME special register”](#) on page 208.

SYSTEM_TIME SENSITIVE

Determines whether references to system-period temporal tables in both static and dynamic SQL statements are affected by the value of the CURRENT TEMPORAL SYSTEM_TIME special register.

YES

References to system-period temporal tables are affected by the value of the CURRENT TEMPORAL SYSTEM_TIME special register. YES is the default value.

NO

References to system-period temporal tables are not affected by the value of the CURRENT TEMPORAL SYSTEM_TIME special register.

For more information, see [“CURRENT TEMPORAL SYSTEM_TIME special register”](#) on page 210.

ARCHIVE SENSITIVE

Determines whether references to archive-enabled tables in SQL statements are affected by the value of the SYSIBMADM.GET_ARCHIVE built-in global variable.

YES

References to archive-enabled tables are affected by the value of the SYSIBMADM.GET_ARCHIVE built-in global variable. YES is the default value.

NO

References to archive-enabled tables are not affected by the value of the SYSIBMADM.GET_ARCHIVE built-in global variable.

For more information, see [“GET_ARCHIVE” on page 330](#).

APPLCOMPAT *applcompat-level*

Specifies the application compatibility behavior for SQL statements in the procedure body. If this option is not specified, the behavior is determined by the *applcompat-level* of the previous bind of the package if one exists, or otherwise by the APPLCOMPAT subsystem parameter.

The following *applcompat-level* values can be specified:

VvvRrMmmm

Compatibility with the behavior of the identified Db2 function level. For example, V12R1M510 specifies compatibility with the highest available Db2 12 function level. The equivalent function level or higher must be activated.

For the new capabilities that become available in each application compatibility level, see:

- [SQL changes in Db2 13 application compatibility levels](#)
- [SQL changes in Db2 12 application compatibility levels](#)

Tip: Extra program preparation steps might be required to increase the application compatibility level for applications that use data server clients or drivers to access Db2 for z/OS. For more information, see [Setting application compatibility levels for data server clients and drivers \(Db2 Application programming and SQL\)](#).

V12R1

Compatibility with the behavior of Db2 12 function level 500. This value has the same result as specifying V12R1M500.

V11R1

Compatibility with the behavior of Db2 11 new-function mode. After migration to Db2 12, this value has the same result as specifying V12R1M100. For more information, see [V11R1 application compatibility level \(Db2 Application programming and SQL\)](#)

V10R1

Compatibility with the behavior of DB2 10 new-function mode. For more information, see [V10R1 application compatibility level \(Db2 Application programming and SQL\)](#).

CONCENTRATE STATEMENTS OFF or CONCENTRATE STATEMENTS WITH LITERALS

Specifies whether each dynamic SQL statement in the routine that specifies literal constants will be cached as a separate unique statement entry in the dynamic statement cache, instead of sharing an existing statement in the cache. Dynamic SQL statements are eligible to share an existing statement in the cache if the new statement meets all of the conditions for sharing a cached version of the same dynamic statement, except that the new statement specifies one or more literal constants that are different than the cached statement.

CONCENTRATE STATEMENTS OFF

Specifies that each dynamic SQL statement that specifies literal constants will be cached as a unique statement entry if it specifies one or more constants that are different than the cached version of the same dynamic statement. CONCENTRATE STATEMENTS OFF is the default dynamic statement caching behavior.

CONCENTRATE STATEMENTS WITH LITERALS

Specifies that each dynamic SQL statement that specifies literal constants will share a cached version of the same dynamic statement that is also prepared using the CONCENTRATE STATEMENTS WITH LITERALS option, if the new dynamic statement meets all of the conditions for sharing the cached statement, and the constants that are specified can be reused in place of the constants in the cached statement.

SQL-routine-body

Specifies the statements that define the body of the SQL procedure. For information on the SQL control statements that are supported in native SQL procedures, see Chapter 8, “SQL procedural language (SQL PL),” on page 2207. If an *SQL-procedure-statement* is the only statement in the procedure body, the statement must not end with a semicolon.

Notes for ALTER PROCEDURE (SQL - native)

Considerations for altering a version of a procedure

To alter a version of a procedure, the environment settings that are in effect when the ALTER PROCEDURE statement is issued must be the same as the environment settings that are in effect when the version of the procedure is first created using the CREATE PROCEDURE or ALTER PROCEDURE statements if one of the following options is specified:

- QUALIFIER
- PACKAGE OWNER
- OPTHINT
- SQL PATH
- DECIMAL (if the value includes a comma)

For the WLM FOR DEBUG MODE clause, the name specified must be representable in the CCSID of the original statement that defined the object or version.

Changing to a native SQL procedure

You cannot change an external SQL procedure to a native SQL procedure. You can drop the external SQL procedure that you want to change by using the DROP statement and create a native SQL procedure with a similar definition using the CREATE PROCEDURE statement. Alternatively, you can create a native SQL procedure using a different schema.

Identifier resolution

See Chapter 8, “SQL procedural language (SQL PL),” on page 2207 for information on how names are resolved to columns, SQL variables, or SQL routines for native SQL procedures. Name resolution is unchanged for external SQL procedures.

If duplicate names are used for columns and SQL variables and parameters, qualify the duplicate names by using the table designator for columns, the procedure name for parameters, and the label name for SQL variables.

Characteristics of the package that is generated for a version of a procedure

The package that is associated with a version of a procedure is named as follows:

- *location* is set to the value of the CURRENT SERVER special register
- *collection-id* (schema) for the package is the same as the schema qualifier of the procedure
- *package-id* is the same as the specific name of the procedure
- *version-id* is the same as the version identifier for the initial version of the procedure

The package is generated using the bind options that correspond to the implicitly or explicitly specified procedure options. In addition to the corresponding bind options, the package is generated using the following bind options:

- DBPROTOCOL(DRDA)
- FLAG(1)
- SQLERROR(NOPACKAGE)
- ENABLE(*)

Application compatibility level considerations for procedure objects

The application compatibility level controls the adoption and use of new capabilities and enhancements. When an object is created or altered, two separate application compatibility levels

are used: one to process the definition of the object, and the other for processing the SQL statements in the object body:

<p>Object definition</p>	<p>The CURRENT APPLICATION COMPATIBILITY special register value is used to process the object definition, except for statements in the object body</p> <p>This application compatibility level is stored in the SYSENVIRONMENT.APPLCOMPAT column. You can use the environment ID value in the catalog definition of the object to locate the SYSENVIRONMENT row with the matching ENVID value.</p> <p>This application compatibility level can be changed when the object is regenerated.</p>
<p>Statements in the object body</p>	<p>The application compatibility level that is implicitly or explicitly specified with the APPLCOMPAT option of the CREATE or ALTER statement is used to process statements in the object body.</p> <p>This application compatibility level is stored in the SYSPACKAGE.APPLCOMPAT column for the package associated with the object definition.</p>

Altering a procedure definition using a lower application compatibility level than the current definition

If the CURRENT APPLICATION COMPATIBILITY special register value is lower than the application compatibility level of the existing object definition, altering an object might result in an error even if the content of the ALTER statement is valid at the current level. The errors can occur when the existing object definition contains some functionality that requires a higher level than the CURRENT APPLICATION COMPATIBILITY special register setting.

Application compatibility levels for regenerating procedure objects

For ALTER statements that regenerate objects, the object definition is reprocessed using the application compatibility setting that is specified implicitly or explicitly by the USING APPLICATION COMPATIBILITY clause that follows the REGENERATE keyword. This application compatibility value replaces the existing value in the SYSENVIRONMENT.APPLCOMPAT column for the environment settings associated with the object definition.

If the USING APPLICATION COMPATIBILITY clause is not specified, the existing application compatibility value in the SYSENVIRONMENT.APPLCOMPAT column for the object definition is used to reprocess the text associated with the object definition.

The behavior of the statements in the body remains controlled by the value the existing APPLCOMPAT option of the object.

Considerations for a procedure that is defined using a TABLE LIKE name AS LOCATOR clause

If a procedure is defined with a table parameter (the TABLE LIKE *name* AS LOCATOR clause was specified in the CREATE PROCEDURE statement to indicate that one of the input parameters is a transition table), the procedure cannot be changed with an ALTER PROCEDURE statement if the change requires that the parameter list be specified. For example, to add or replace a version of a native SQL procedure, the procedure must be dropped and re-created.

Considerations for SQL processor programs

SQL processor programs, such as SPUFI, the command line processor, and DSNTEP2, might not correctly parse SQL statements in the routine body that end with semicolons. These processor programs accept multiple SQL statements as input, with each statement separated with a terminator character. Processor programs that use a semicolon as the SQL statement terminator can truncate a CREATE FUNCTION statement with embedded semicolons and pass only a portion of it to Db2. Therefore, you might need to change the SQL terminator character for these processor programs. For information on changing the terminator character for SPUFI and DSNTEP2, see [Setting the SQL](#)

terminator character in a SPUFI input data set ([Db2 Application programming and SQL](#)) and [DSNTEP2](#) and [DSNTEP4](#) sample programs ([Db2 Application programming and SQL](#)).

Correspondence of procedure options to BIND options

The following table lists the corresponding bind command options for specific CREATE PROCEDURE and ALTER PROCEDURE options. For more information about the bind options, see [BIND](#) and [REBIND](#) options for packages, plans, and services ([Db2 Commands](#)).

Correspondence of procedure options to bind options

CREATE PROCEDURE or ALTER PROCEDURE option	Bind commands option
ACCELERATION WAITFORDATA <i>nnnn.m</i>	ACCELERATIONWAITFORDATA(<i>nnnn.m</i>)
ACCELERATOR <i>accelerator-name</i>	ACCELERATOR(<i>accelerator-name</i>)
APPLICATION ENCODING SCHEME ASCII	ENCODING(ASCII)
APPLICATION ENCODING SCHEME EBCDIC	ENCODING(EBCDIC)
APPLICATION ENCODING SCHEME UNICODE	ENCODING(UNICODE)
ARCHIVE SENSITIVE NO	ARCHIVESENSITIVE(NO)
ARCHIVE SENSITIVE YES	ARCHIVESENSITIVE(YES)
BUSINESS_TIME SENSITIVE NO	BUSTIMESENSITIVE(NO)
BUSINESS_TIME SENSITIVE YES	BUSTIMESENSITIVE(YES)
CURRENT DATA NO	CURRENTDATA(NO)
CURRENT DATA YES	CURRENTDATA(YES)
DEFER PREPARE	DEFER(PREPARE)
NODEFER PREPARE	NODEFER(PREPARE)
DEGREE 1	DEGREE(1)
DEGREE ANY	DEGREE(ANY)
DYNAMICRULES RUN	DYNAMICRULES(RUN)
DYNAMICRULES BIND	DYNAMICRULES(BIND)
DYNAMICRULES DEFINEBIND	DYNAMICRULES(DEFINEBIND)
DYNAMICRULES DEFINERUN	DYNAMICRULES(DEFINERUN)
DYNAMICRULES INVOKEBIND	DYNAMICRULES(INVOKEBIND)
DYNAMICRULES INVOKERUN	DYNAMICRULES(INVOKERUN)
GET_ACCEL_ARCHIVE NO	GETACCELARCHIVE(NO)
GET_ACCEL_ARCHIVE YES	GETACCELARCHIVE(YES)
ISOLATION LEVEL CS	ISOLATION(CS)
ISOLATION LEVEL RS	ISOLATION(RS)
ISOLATION LEVEL RR	ISOLATION(RR)
ISOLATION LEVEL UR	ISOLATION(UR)
OPTHINT <i>string-constant</i>	OPTHINT(<i>hint-id</i>)
PACKAGE OWNER <i>authorization-name</i>	OWNER(<i>authorization-id</i>)

CREATE PROCEDURE or ALTER PROCEDURE option	Bind commands option
QUALIFIER <i>schema-name</i>	QUALIFIER(<i>qualifier-name</i>)
QUERY ACCELERATION NONE	QUERYACCELERATION(NONE)
QUERY ACCELERATION ENABLE	QUERYACCELERATION(ENABLE)
QUERY ACCELERATION ENABLE WITH FAILBACK	QUERYACCELERATION(ENABLE WITH FAILBACK)
QUERY ACCELERATION ELIGIBLE	QUERYACCELERATION(ELIGIBLE)
QUERY ACCELERATION ALL	QUERYACCELERATION(ALL)
RELEASE AT COMMIT	RELEASE(COMMIT)
RELEASE AT DEALLOCATE	RELEASE(DEALLOCATE)
REOPT ALWAYS	REOPT(ALWAYS)
REOPT NONE	REOPT(NONE)
REOPT ONCE	REOPT(ONCE)
ROUNDING DEC_ROUND_CEILING	ROUNDING(CEILING)
ROUNDING DEC_ROUND_DOWN	ROUNDING(DOWN)
ROUNDING DEC_ROUNDING_FLOOR	ROUNDING(FLOOR)
ROUNDING DEC_ROUNDING_HALF_DOWN	ROUNDING(HALFDOWN)
ROUNDING DEC_ROUNDING_HALF_EVEN	ROUNDING(HALFEVEN)
ROUNDING DEC_ROUNDING_HALF_UP	ROUNDING(HALFUP)
ROUNDING DEC_ROUNDING_UP	ROUNDING(UP)
SQL PATH <i>path-specification</i>	PATH(<i>path-specification</i>)
SYSTEM_TIME SENSITIVE NO	SYSTIMESENSITIVE(NO)
SYSTEM_TIME SENSITIVE YES	SYSTIMESENSITIVE(YES)
VALIDATE BIND	VALIDATE(BIND)
VALIDATE RUN	VALIDATE(RUN)
WITH EXPLAIN	EXPLAIN(YES)
WITHOUT EXPLAIN	EXPLAIN(NO)
WITH IMMEDIATE WRITE	IMMEDWRITE(YES)
WITHOUT IMMEDIATE WRITE	IMMEDWRITE(NO)
WITH KEEP DYNAMIC	KEEPDYNAMIC(YES)
WITHOUT KEEP DYNAMIC	KEEPDYNAMIC(NO)

Invalidation of packages

This statement might invalidate all packages that depend on target objects, and sometimes other related objects through cascading effects, depending on the clauses and keywords specified and other factors.

ALTER PROCEDURE with the ACTIVATE VERSION option invalidates all packages that are dependent on a previous version of the procedure. (The ACTIVATE VERSION does not invalidate packages if the value of *routine-version-id* is the same as the current active version of the procedure.)

When a version of an SQL procedure is altered to change certain options that are specified for the active version, all application packages that refer to that procedure are marked invalid, and those invoking packages require a rebind. This includes changes to certain bind options and routine options that result in the implicit regeneration of the procedure. These options are marked accordingly in the following table in columns "Change requires rebind of invoking applications" and "Change results in implicit regeneration of the entire body of the procedure." For more information, see [Changes that invalidate packages \(Db2 Application programming and SQL\)](#).

Implicit rebind and regeneration

When certain attributes of a native SQL procedure are changed, the body of the procedure might be rebound or regenerated. The columns "Change results in implicit regeneration of the entire body of the procedure" and "Change results in implicit rebind of non-control statements in the body of the procedure" in the following table summarize when implicit rebind and regeneration occurs when specific options are changed.

Table 175. CREATE PROCEDURE and ALTER PROCEDURE options that result in rebind or regeneration when changed.

CREATE PROCEDURE or ALTER PROCEDURE option	Change requires rebind of invoking applications?	Change results in implicit rebind of the non-control statements of the body of the procedure?	Change results in implicit regeneration of the entire body of the procedure?
ACCELERATION WAITFOR DATA	No	Yes	No
ACCELERATOR	No	Yes	No
ALLOW DEBUG MODE, DISALLOW DEBUG MODE, or DISABLE DEBUG MODE	Yes "1" on page 1222, "2" on page 1222	Yes "1" on page 1222	Yes
APPLICATION ENCODING SCHEME	Yes	Yes	Yes
ARCHIVE SENSITIVE	Yes	Yes	Yes
ASUTIME	Yes	No	No
BUSINESS_TIME SENSITIVE	Yes	Yes	Yes
COMMIT ON RETURN	Yes	No	No
CURRENT DATA	No	Yes	No
DATE FORMAT	Yes	Yes	Yes
DECIMAL	Yes	Yes	Yes
DEFER PREPARE or NODEFER PREPARE	No	Yes	No
DEGREE	No	Yes	No
DYNAMIC RESULT SETS	Yes	No	No
DYNAMICRULES	No	Yes	No
FOR UPDATE CLAUSE OPTIONAL or FOR UPDATE CLAUSE REQUIRED	Yes	Yes	Yes
GET_ACCEL_ARCHIVE	Yes	Yes	Yes

Table 175. CREATE PROCEDURE and ALTER PROCEDURE options that result in rebind or regeneration when changed. (continued)

CREATE PROCEDURE or ALTER PROCEDURE option	Change requires rebind of invoking applications?	Change results in implicit rebind of the non-control statements of the body of the procedure?	Change results in implicit regeneration of the entire body of the procedure?
INHERIT SPECIAL REGISTERS or DEFAULT SPECIAL REGISTERS	Yes	No	No
ISOLATION LEVEL	No	Yes	No
MODIFIES SQL DATA, READS SQL DATA, or CONTAINS SQL	Yes	Yes	Yes
NOT DETERMINISTIC or DETERMINISTIC	No	No	No
OPTHINT	No	Yes	No
PACKAGE OWNER	No	Yes	No
QUALIFIER	No	Yes	No
QUERYACCELERATION	Yes	Yes	Yes
RELEASE AT COMMIT or RELEASE AT DEALLOCATE	No	Yes	No
REOPT	No	Yes	No
SQL PATH	No	Yes	No
STOP AFTER SYSTEM DEFAULT FAILURES, STOP AFTER nn FAILURES, or CONTINUE AFTER FAILURES	Yes	No	No
SYSTEM_TIME SENSITIVE	Yes	Yes	Yes
TIME FORMAT	Yes	Yes	Yes
VALIDATE RUN or VALIDATE BIND	No	Yes	No
WITH EXPLAIN or WITHOUT EXPLAIN	No	Yes	No
WITH IMMEDIATE WRITE or WITHOUT IMMEDIATE WRITE	No	Yes	No
WITH KEEP DYNAMIC or WITHOUT KEEP DYNAMIC	No	Yes	No
WLM ENVIRONMENT FOR DEBUG MODE	Yes	No	No

Note:

1. The procedure package is rebound or regenerated if a value of ALLOW DEBUG MODE is changed to DISALLOW DEBUG MODE.
2. Invoking applications are invalidated if a value of DISALLOW DEBUG MODE is changed to DISABLE DEBUG MODE.

Considerations for SYSENVIRONMENTS catalog table

An ALTER statement that specifies a new environment settings will result in a new row being added to the SYSENVIRONMENTS catalog table. The new row will be added even if an error is subsequently encountered during processing of the ALTER statement. Thus, a new SYSENVIRONMENTS row might be added even for an ALTER statement that fails.

Compatibilities:

For compatibility with previous versions of Db2, when any of the following options are implicitly or explicitly specified as part of *option-list*, a warning is issued, but the statement is executed. However, if REPLACE or ADD VERSION is specified with one of the following options, an error is issued, and the statement does not execute. For example, if ADD VERSION and STAY RESIDENT are specified, an error is issued.

- STAY RESIDENT
- PROGRAM TYPE
- RUN OPTIONS
- NO DBINFO
- COLLID or NOCOLLID
- SECURITY
- PARAMETER STYLE GENERAL WITH NULLS
- STOP AFTER SYSTEM DEFAULT FAILURES
- STOP AFTER *nn* FAILURES
- CONTINUE AFTER FAILURES

If WLM ENVIRONMENT is specified for a native SQL procedure, WLM ENVIRONMENT FOR DEBUG MODE must be specified.

For compatibility with the CREATE PROCEDURE statement, the following clause can be specified, but will be ignored:

- LANGUAGE SQL

Altering obfuscated procedures

Obfuscated procedures cannot be altered in any way.

Alternative syntax and synonyms:

To provide compatibility with previous releases of Db2 or other products in the Db2 family, Db2 supports the following keywords:

- RESULT SET, RESULT SETS, and DYNAMIC RESULT SET as synonyms for DYNAMIC RESULT SETS.
- VARIANT as a synonym for NOT DETERMINISTIC
- NOT VARIANT as a synonym for DETERMINISTIC

Considerations for catalog comments for a routine definition

When a function definition is replaced any existing comment in the catalog for the definition is removed, and when a function definition is regenerated any existing comment in the catalog for the definition is retained.

Example for ALTER PROCEDURE (SQL - native)

Example 1

The following statement changes the existing procedure options for the active version of the UPDATE_SALARY_1 native SQL procedure. If you need to change a different version of the procedure, you would specify `VERSION routine-version-id` in place of `ACTIVE VERSION`. Note that the `ALTER` clause that precedes the version specification can be omitted.

```
ALTER PROCEDURE UPDATE_SALARY_1
  ALTER ACTIVE VERSION
  NOT DETERMINISTIC
  CALLED ON NULL INPUT
  ALLOW DEBUG MODE
  ASUTIME LIMIT 10
```

Example 2

To change the procedure body of any existing version of a procedure, you need to use the `REPLACE` clause. The following statement changes both the procedure body and the existing SQL data access option for version V2 of the UPDATE_SALARY_1 SQL procedure. Note that the list of parameters is specified even though no changes are made to the list. To replace an existing version of a procedure, you must specify the list of parameters, any options that are to have non-default values (even if those options are specified in the version of the procedure that you are replacing), and the body of the procedure.

```
ALTER PROCEDURE UPDATE_SALARY_1
  REPLACE VERSION V2 (P1 INTEGER, P2 CHAR(5))
  MODIFIES SQL DATA
  UPDATE EMP SET SALARY = SALARY * RATE
  WHERE EMPNO = EMPLOYEE_NUMBER;
```

Example 3

To add a new version of an existing procedure, use the `ADD VERSION` clause. The following statement adds a new version of the UPDATE_SALARY_1 procedure to apply a larger salary increase. Note that the list of parameters is specified even though the new version of the procedure uses the same parameters as the existing version of the procedure. To add a new version of a procedure, you must specify the list of parameters, any options that will have non-default values, and the body of the procedure.

```
ALTER PROCEDURE UPDATE_SALARY_1
  ADD VERSION V3 (P1 INTEGER, P2 CHAR(5))
  UPDATE EMP SET SALARY = SALARY * (RATE*10)
  WHERE EMPNO = EMPLOYEE_NUMBER;
```

Example 4

When the new version of the procedure has been defined, as in Example 3, you must use the `ALTER PROCEDURE` statement with the `ACTIVATE VERSION` clause if the new version of the procedure is to be the currently active version, as in the following example.

```
ALTER PROCEDURE UPDATE_SALARY_1
  ACTIVATE VERSION V3;
```

Example 5

To regenerate the currently active version of a procedure, use the following statement.

```
ALTER PROCEDURE UPDATE_SALARY_1
  REGENERATE ACTIVE VERSION;
```

Related concepts

[SQL procedures \(Db2 Application programming and SQL\)](#)

Related tasks

[Altering stored procedures \(Db2 Administration Guide\)](#)

[Changing an existing version of a native SQL procedure \(Db2 Application programming and SQL\)](#)

[Regenerating an existing version of a native SQL procedure \(Db2 Application programming and SQL\)](#)

ALTER SEQUENCE statement

The ALTER SEQUENCE statement changes the attributes of a sequence at the current server. Only future values of the sequence are affected by the ALTER SEQUENCE statement.

Invocation for ALTER SEQUENCE

This statement can be embedded in an application program or issued interactively. It is an executable statement that can be dynamically prepared only if DYNAMICRULES RUN behavior is in effect. For more information, see [“Authorization IDs and dynamic SQL”](#) on page 94.

Authorization for ALTER SEQUENCE

The privilege set that is defined below must include at least one of the following:

- Ownership of the sequence
- The ALTER privilege for the sequence
- The ALTERIN privilege on the schema
- SYSADM or SYSCTRL authority
- System DBADM
- Installation SYSOPR authority (when the current SQLID of the process is set to SYSINSTL)

Installation SYSADM privilege is required to alter the SYSIBM.DSNSEQ_IMPLICITDB sequence (which specifies the maximum number of implicitly created databases).

The authorization ID that matches the schema name implicitly has the ALTERIN privilege on the schema.

Privilege set: If the statement is embedded in an application program, the privilege set is the privileges that are held by the owner of the package. If the statement is dynamically prepared, the privilege set is the union of the privilege sets that are held by each authorization ID and role of the process.

Syntax for ALTER SEQUENCE

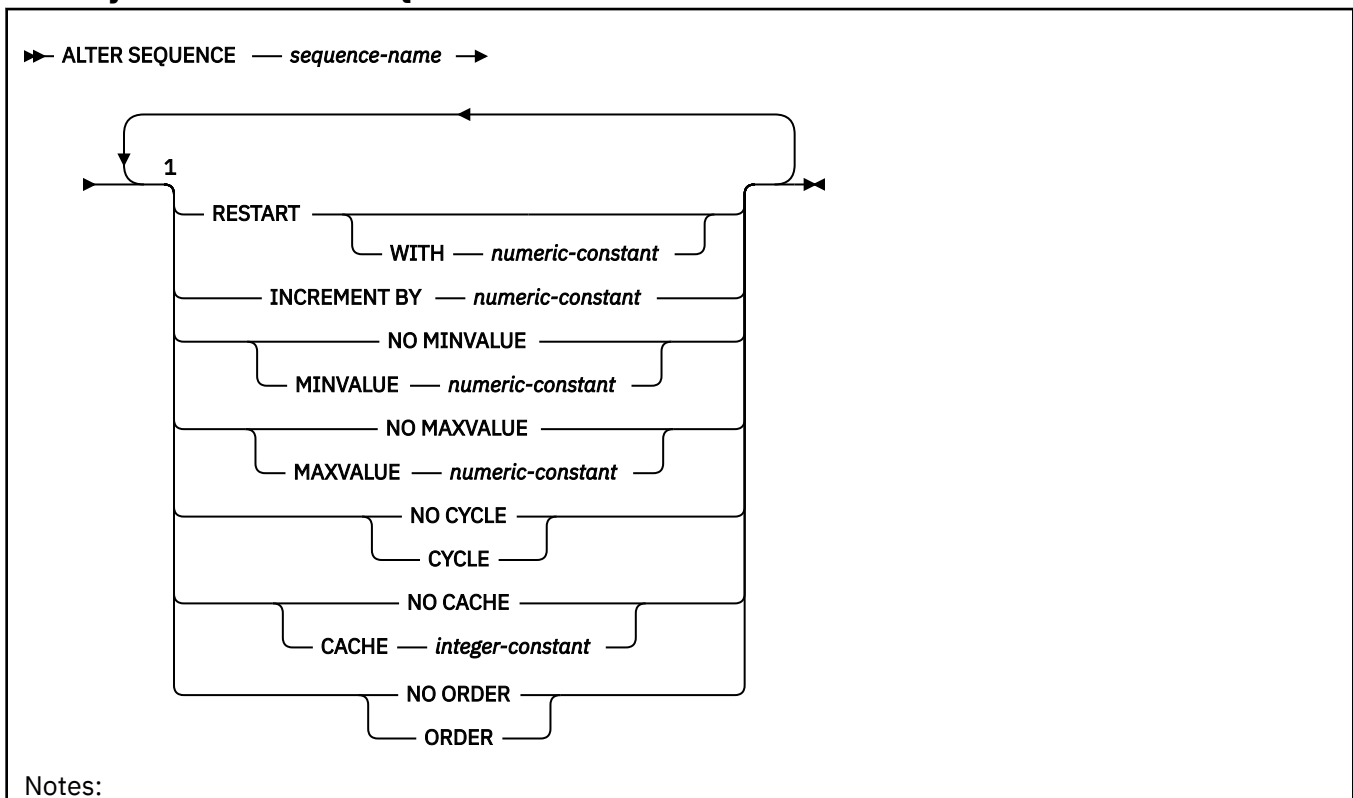

¹ At least one option must be specified and the same clause must not be specified more than once. Separator commas can be specified between sequence attributes when a sequence is defined.

Description for ALTER SEQUENCE

sequence-name

Identifies the sequence. The combination of sequence name and the implicit or explicit qualifier must identify an existing sequence at the current server. *sequence-name* must not identify a sequence that is generated by Db2 for an identity column or a DB2_GENERATED_DOCID_FOR_XML column.

RESTART

Restarts the sequence. If *numeric-constant* is not specified, the sequence is restarted at the value specified implicitly or explicitly as the starting value on the CREATE SEQUENCE statement that originally created the sequence. RESTART does not change the original START WITH value.

WITH *numeric-constant*

Specifies the value at which to restart the sequence. The value can be any positive or negative value that could be assigned to the a column of the data type that is associated with the sequence without non-zero digits existing to the right of the decimal point. The range used for cycles is defined by MINVALUE and MAXVALUE. However, MAXVALUE and MINVALUE do not constrain the RESTART WITH *numeric-constant* value. That is, the RESTART WITH clause can be used to start the generation of values outside the range that is used for cycles. For more information, see [“Specifying RESTART WITH values outside the range for cycles” on page 1227](#).

If RESTART is not specified, the sequence is not restarted. Instead, it resumes with the current values in effect for all the options after the ALTER statement is issued.

After a sequence is restarted or changed to allow cycling, sequence numbers might be duplicates of values generated by the sequence previously.

INCREMENT BY *numeric-constant*

Specifies the interval between consecutive values of the sequence. The value can be any positive or negative value (including 0) that could be assigned to a column of the data type that is associated with the sequence without any non-zero digits existing to the right of the decimal point.

If INCREMENT BY *numeric-constant* is positive, the sequence ascends. If INCREMENT BY *numeric-constant* is negative, the sequence descends. If INCREMENT BY *numeric-constant* is 0, the sequence is treated as an ascending sequence.

The absolute value of INCREMENT BY can be greater than the difference between MAXVALUE and MINVALUE.

NO MINVALUE or MINVALUE

Specifies whether or not there is a minimum end point of the range of values for the sequence.

NO MINVALUE

Specifies that the minimum end point of the range of values for the sequence has not been specified explicitly. In such a case, the value for MINVALUE becomes one of the following:

- For an ascending sequence, the value is the original starting value.
- For a descending sequence, the value is the minimum of the data type that is associated with the sequence.

MINVALUE *numeric-constant*

Specifies the minimum value at which a descending sequence either cycles or stops generating values, or an ascending sequence cycles to after reaching the maximum value. The last value that is generated for a cycle of a descending sequence will be equal to or greater than this value. MINVALUE is the value to which an ascending sequence cycles to after reaching the maximum value.

The value can be any positive or negative value that could be assigned to the a column of the data type that is associated with the sequence without non-zero digits existing to the right of the decimal point. The value must be less than or equal to the maximum value.

NO MAXVALUE or MAXVALUE

Specifies whether or not there is a maximum end point of the range of values for the sequence.

NO MAXVALUE

Specifies either explicitly or implicitly that the minimum end point of the range of values for the sequence has not be set. In such a case, the default value for MAXVALUE becomes one of the following:

- For an ascending sequence, the value is the maximum value of the data type that is associated with the sequence
- For a descending sequence, the value is the original starting value.

If NO MAXVALUE is explicitly specified in the ALTER SEQUENCE statement, the value of the MAXVALUE column in the catalog table is reset to the maximum value of the data type associated with the sequence if the sequence is ascending or the value stored in the START column of the catalog table if the sequence is descending. Whether the sequence is ascending or descending depends on whether or not the INCREMENT BY option is reset. If it is, the new INCREMENT BY VALUE determines if the sequence is ascending or descending. If it is not explicitly reset, the value stored in the INCREMENT column of the catalog table determines if the sequence is ascending or descending.

MAXVALUE *numeric-constant*

Specifies the maximum value at which an ascending sequence either cycles or stops generating values or a descending sequence cycles to after reaching the minimum value. The last value that is generated for a cycle of an ascending sequence will be less than or equal to this value. MAXVALUE is the value to which a descending sequence cycles to after reaching the minimum value.

The value can be any positive or negative value that could be assigned to the a column of the data type that is associated with the sequence without non-zero digits existing to the right of the decimal point. The value must be greater than or equal to the minimum value.

NO CYCLE or CYCLE

Specifies whether or not the sequence should continue to generate values after reaching either its maximum or minimum value. The boundary of the sequence can be reached either with the next value landing exactly on the boundary condition or by overshooting it.

NO CYCLE

Specifies that the sequence cannot generate more values once the maximum or minimum value for the sequence has been reached.

CYCLE

Specifies that the sequence continue to generate values after either the maximum or minimum value has been reached. If this option is used, after an ascending sequence reaches its maximum value, it generates its minimum value. After a descending sequence reaches its minimum value, it generates its maximum value. The maximum and minimum values for the sequence defined by the MINVALUE and MAXVALUE options determine the range that is used for cycling.

When CYCLE is in effect, duplicate values can be generated by the sequence. When a sequence is defined with CYCLE, any application conversion tools for converting applications from other vendor platforms to Db2 should also explicitly specify MINVALUE, MAXVALUE, and START WITH values.

NO CACHE or CACHE

Specifies whether or not to keep some preallocated values in memory for faster access. This is a performance and tuning option.

NO CACHE

Specifies that values of the sequence are not to be preallocated. This option ensures that there is not a loss of values in the case of a system failure. When NO CACHE is specified, the values of the

sequence are not stored in the cache. In this case, every request for a new value for the sequence results in synchronous I/O to the log.

CACHE *integer-constant*

Specifies the maximum number of sequence values that Db2 can preallocate and keep in memory. Preallocating values in the cache reduces synchronous I/O when values are generated for the sequence. The actual number of values that Db2 caches is always the lesser of the number in effect for the CACHE option and the number of remaining values within the logical range. Thus, the CACHE value is essentially an upper limit for the size of the cache.

In the event the system is shut down (either normally or through a system failure), all cached sequence values that have not been used in committed statements are lost (that is, they will never be used). The value specified for the CACHE option is the maximum number of sequence values that could be lost when the system is shut down.

The minimum value is 2.

In a data sharing environment, you can use the CACHE and NO ORDER options to allow multiple Db2 members to cache sequence values simultaneously.

NO ORDER or ORDER

Specifies whether the sequence numbers must be generated in order of request.

NO ORDER

Specifies that the sequence numbers do not need to be generated in order of request.

ORDER

Specifies that the sequence numbers are generated in order of request. Specifying ORDER might disable the caching of values. There is no guarantee that values are assigned in order across the entire server unless NO CACHE is also specified. ORDER applies only to a single-application process.

In a data sharing environment, if the CACHE and NO ORDER options are in effect, multiple caches can be active simultaneously, and the requests for next value assignments from different Db2 members might not result in the assignment of values in strict numeric order. For example, if members DB2A and DB2B are using the same sequence, and DB2A gets the cache values 1 to 20 and DB2B gets the cache values 21 to 40, the actual order of values assigned would be 1,21,2 if DB2A requested for next value first, then DB2B requested, and then DB2A again requested. Therefore, to guarantee that sequence numbers are generated in strict numeric order among multiple Db2 members using the same sequence concurrently, specify the ORDER option.

Notes for ALTER SEQUENCE

Altering a sequence

The changes to the attributes of a sequence take effect after the ALTER SEQUENCE statement is committed. Only future sequence numbers are affected by the ALTER SEQUENCE statement. If the ALTER SEQUENCE request results in an error or is rolled back, nothing is changed; however, unused cache values might be lost.

- The data type of a sequence cannot be changed. Instead, drop and re-create the sequence specifying the desired data type for the new sequence.
- All cached values are lost when a sequence is altered.
- After restarting a sequence or changing it to cycle, it is possible that a generated value will duplicate a value previously generated for that sequence.

Specifying RESTART WITH values outside the range for cycles

The RESTART WITH value is not constrained by the values of MINVALUE and MAXVALUE. That is, if the RESTART WITH value is greater than MAXVALUE, it has the following results:

- An ascending sequence generates the RESTART WITH value and then cycles to MINVALUE if CYCLE is in effect. If NO CYCLE is in effect, the sequence generates the RESTART WITH value one time, and the next attempt to generate a sequence value returns an error.

- A descending sequence generates the RESTART WITH value and then generates values according to the INCREMENT BY specification until it reaches MINVALUE. MAXVALUE does not constrain the generation of values for a descending sequence in this situation, so many values greater than MAXVALUE can potentially be generated.

Likewise, if the RESTART WITH value is less than MINVALUE, it has the following results:

- A descending sequence generates the RESTART WITH value and then cycles to MAXVALUE if CYCLE is in effect. If NO CYCLE is in effect, the sequence generates the RESTART WITH value one time, and the next attempt to generate a sequence value returns an error.
- An ascending sequence generates the RESTART WITH value and then generates values according to the INCREMENT BY specification until it reaches MAXVALUE. MINVALUE does not constrain the generation of values for an ascending sequence in this situation, so many values less than MINVALUE can potentially be generated.

Alternative syntax and synonyms

To provide compatibility with previous releases of Db2 or other products in the Db2 family, Db2 supports the following keywords:

- NOCACHE (single key word) as a synonym for NO CACHE
- NOCYCLE (single key word) as a synonym for NO CYCLE
- NOMINVALUE (single key word) as a synonym for NO MINVALUE
- NOMAXVALUE (single key word) as a synonym for NO MAXVALUE
- NOORDER (single key word) as a synonym for NO ORDER

Examples for ALTER SEQUENCE

Example 1: Reset a sequence to the START WITH value to generate the numbers from 1 up to the number of rows in the table:

```
ALTER SEQUENCE org_seq
RESTART;
```

ALTER STOGROUP statement

The ALTER STOGROUP statement changes the description of a storage group at the current server.

Invocation for ALTER STOGROUP

This statement can be embedded in an application program or issued interactively. It is an executable statement that can be dynamically prepared only if DYNAMICRULES RUN behavior is in effect. For more information, see [“Authorization IDs and dynamic SQL” on page 94](#).

Authorization for ALTER STOGROUP

The privilege set that is defined below must include one of the following:

- Ownership of the storage group
- SYSADM or SYSCTRL authority
- Installation SYSOPR authority (when the current SQLID of the process is set to SYSINSTL)

Privilege set: If the statement is embedded in an application program, the privilege set is the privileges that are held by the owner of the package. If the statement is dynamically prepared, the privilege set is the union of the privilege sets that are held by each authorization ID and role of the process.

Syntax for ALTER STOGROUP

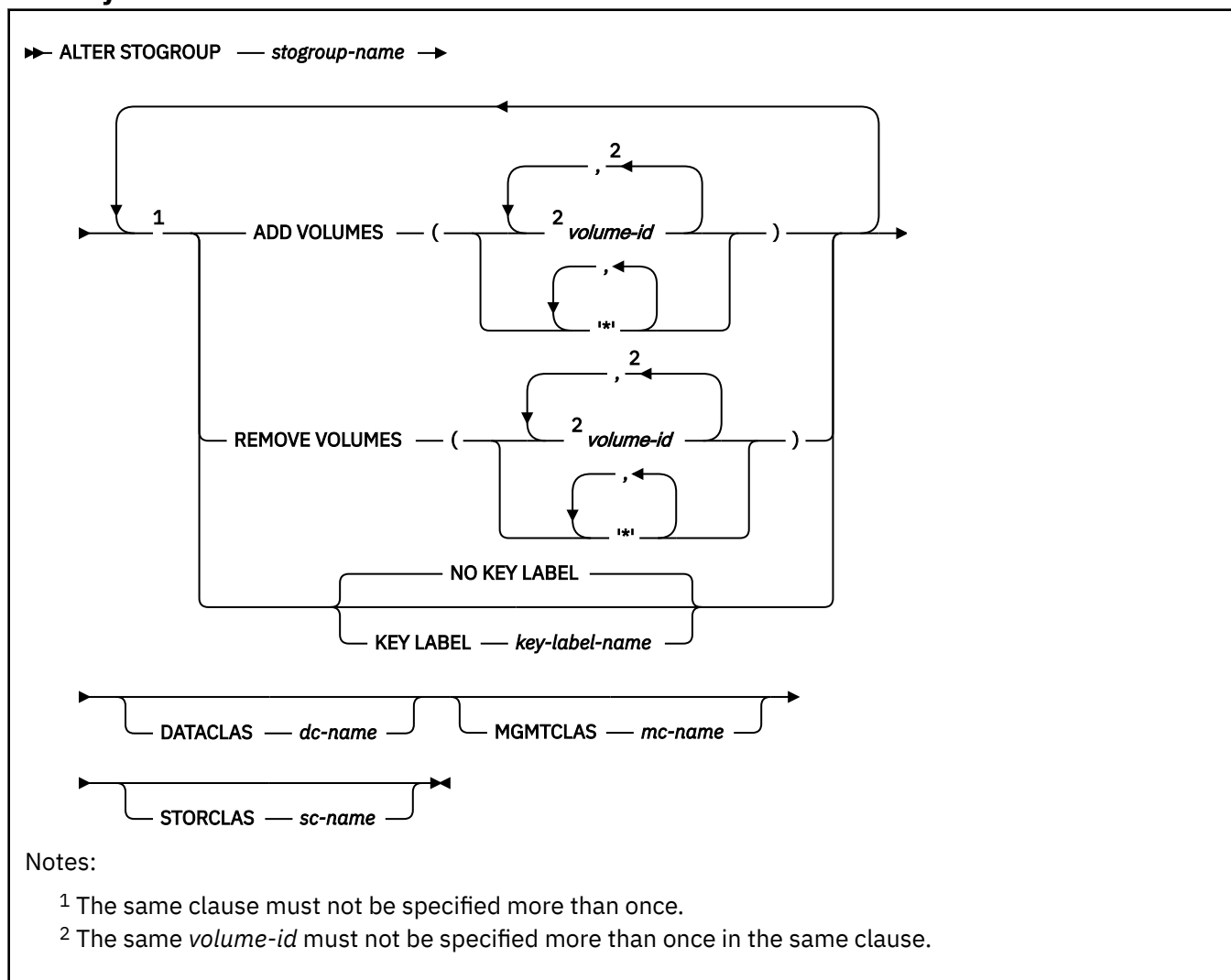

Description for ALTER STOGROUP

stogroup-name

Identifies the storage group to be altered. The name must identify a storage group that exists at the current server.

ADD VOLUMES(*volume-id*,...) or ADD VOLUMES('*'...)

Adds volumes to the storage group. Each *volume-id* is the volume serial number of a storage volume to be added. It can have a maximum of six characters and is specified as an identifier or a string constant.

A *volume-id* must not be specified if any volume of the storage group is designated by an asterisk (*). An asterisk must not be specified if any volume of the storage group is designated by a *volume-id*.

You cannot add a volume that is already in the storage group unless you first remove it with REMOVE VOLUMES.

Asterisks are recognized only by Storage Management Subsystem (SMS). If the data set that is associated with the storage group is non-SMS managed, either ADD VOLUMES or REMOVE VOLUMES must be specified. Neither ADD VOLUMES or REMOVE VOLUMES is required if DATACLAS, MGMTCLAS, or STORCLAS is specified. SMS usage is recommended, rather than using Db2 to allocate data to specific volumes. Having Db2 select the volume requires non-SMS usage or assigning an SMS Storage Class with guaranteed space. However, because guaranteed space reduces the benefits of SMS allocation, it is not recommended.

If you do choose to use specific volume assignments, additional manual space management must be performed. Free space must be managed for each individual volume to prevent failures during the initial allocation and extension. This process generally requires more time for space management and results in more space shortages. Guaranteed space should be used only where the space needs are relatively small and do not change.

REMOVE VOLUMES(*volume-id*,...) or REMOVE VOLUMES('*',...)

Removes volumes from the storage group. Each *volume-id* is the volume serial number of a storage volume to be removed. Each *volume-id* must identify a volume that is in the storage group.

The REMOVE VOLUMES clause is applied to the current list of volumes before the ADD VOLUMES clause is applied. Removing a volume from a storage group does not affect existing data, but a volume that has been removed is not used again when the storage group is used to allocate storage for table spaces or index spaces.

Asterisks are recognized only by Storage Management Subsystem (SMS). If the data set that is associated with the storage group is non SMS managed, either ADD VOLUMES or REMOVE VOLUMES must be specified. Neither ADD VOLUMES or REMOVE VOLUMES is required if DATACLAS, MGMTCLAS, or STORCLAS is specified.

DATACLAS *dc-name*

Identifies the name of the SMS data class to associate with the Db2 storage group. The SMS data class name must be from 1-8 characters in length. The SMS storage administrator defines the data class that can be used. DATACLAS must not be specified more than one time.

MGMTCLAS *mc-name*

Identifies the name of the SMS management class to associate with the Db2 storage group. The SMS management class name must be from 1-8 characters in length. The SMS storage administrator defines the management class that can be used. MGMTCLAS must not be specified more than one time.

STORCLAS *sc-name*

Identifies the name of the SMS storage class to associate with the Db2 storage group. The SMS storage class name must be from 1-8 characters in length. The SMS storage administrator defines the storage class that can be used. STORCLAS must not be specified more than one time.

FL 502 KEY LABEL *key-label-name* or NO KEY LABEL

Specifies whether a key label is specified at the storage group level for encryption. For the changed KEY LABEL value to take effect, a subsequent REORG of the table spaces or indexes that use the storage group is required.

KEY LABEL *key-label-name*

Specifies the default key label that is used to encrypt any data set allocated for the table spaces and index spaces using the storage group.

The Db2 address space RACF user ID or group must be permitted access to the key label in RACF.

The key label can be overridden when the data set is allocated. For details about the order of precedence, see [“Notes for ALTER STOGROUP” on page 1230](#).

NO KEY LABEL

Indicates that there is no key label specified at the storage group level for encryption.

Notes for ALTER STOGROUP

Work file databases:

If the storage group altered contains data sets in a work file database, the database must be stopped and restarted for the effects of the ALTER to be recognized. To stop and restart a database, issue the following commands:

```
-STOP DATABASE(database-name)  
-START DATABASE(database-name)
```

Device types:

When the storage group is used at run time, an error can occur if the volumes in the storage group are of different device types, or if a volume is not available to z/OS for dynamic allocation of data sets.

When a storage group is used to extend a data set, all volumes in the storage group must be of the same device type as the volumes used when the data set was defined. Otherwise, an extend failure occurs if an attempt is made to extend the data set.

Number of volumes:

There is no specific limit on the number of volumes that can be defined for a storage group. However, the maximum number of volumes that can be managed for a storage group is 133.

If the VOLUMES clause is specified, the maximum number of volumes is 59.

Verifying the existence of volumes and classes:

When processing the VOLUMES, DATACLAS, MGMTCLAS, or STORCLAS clauses, Db2 does not check the existence of the volumes or classes or determine the types of devices that are identified or if SMS is active. Later, when the storage group allocates data sets, the list of volumes is passed in the specified order to Data Facilities (DFSMSdfp).

SMS data set management:

You can have Storage Management Subsystem (SMS) manage the storage needed for the objects that the storage group supports. To do so, specify ADD VOLUMES(*) and REMOVE VOLUMES(*current-vols*) in the ALTER statement, where *current-vols* is the list of the volumes currently assigned to the storage group. SMS manages every data set created later for the storage group. SMS does not manage data sets created before the execution of the statement.

You can also specify ADD VOLUMES(*volume-id*) and REMOVE VOLUMES(*) to make the opposite change.

For considerations for using SMS to manage data sets, see [Implementing Db2 storage groups \(Db2 Administration Guide\)](#).

Key label requirement

To use a key label for encryption, the VSAM data sets for the page sets need to be associated with an SMS Data Class that has extended format capability (EF enabled).

Determining a key label for base table space and associated objects

When a key label is specified at the table level, Db2 provides the key label to DFSMS to encrypt all the table spaces and index spaces associated with the table. This includes base table space, auxiliary table spaces, XML table spaces, index spaces, and clone table space, regardless of whether the base table space or associated objects are explicitly or implicitly created. Db2 does not enforce any key label relationship between the base table and an associated history or archive table. The key label for the archive and the history tables has to be set independent of the base table. If there is no key label specified at the table level, Db2 will provide the key label to DFSMS specified for the storage group.

When Db2 calls DFSMS to allocate the dataset for table space or index space, DFSMS uses its order of precedence to determine the key label and can override the key label specified by Db2.

DFSMS order of precedence:

- RACF data set profile
- JCL, dynamic allocation, TSO ALLOCATE
- SMS data class construct

If the security administrator has specified a key label for the RACF data set profile, that key label takes precedence over the Db2 provided key label. The REPORT utility can be run to determine the key label used for encryption.

Examples for ALTER STOGROUP

Example 1: Alter storage group DSN8G120. Add volumes DSNV04 and DSNV05.

```
ALTER STOGROUP DSN8G120
  ADD VOLUMES (DSNV04,DSNV05);
```

Example 2: Alter storage group DSN8G120. Remove volumes DSNV04 and DSNV05.

```
ALTER STOGROUP DSN8G120
  REMOVE VOLUMES (DSNV04,DSNV05);
```

Example 3: Alter storage group DSNCG120 to remove the key label.

```
ALTER STOGROUP DSNCG120
  NO KEY LABEL;
```

ALTER TABLE statement

The ALTER TABLE statement changes the description of a table at the current server.

Invocation for ALTER TABLE

This statement can be embedded in an application program or issued interactively. It is an executable statement that can be dynamically prepared only if DYNAMICRULES RUN behavior is in effect. For more information, see [“Authorization IDs and dynamic SQL”](#) on page 94.

Authorization for ALTER TABLE

The privilege set that is defined below must include at least one of the following:

- The ALTER privilege on the table
- Ownership of the table
- DBADM authority for the database
- SYSADM or SYSCTRL authority
- System DBADM
- Installation SYSOPR authority (when the current SQLID of the process is set to SYSINSTL)

To alter a system-period temporal table when one or more of the changes also result in changes to the associated history table, the privileges that are held by the authorization ID of the statement must also include at least one of the following:

- The ALTER privilege on the history table
- Ownership of the history table
- DBADM authority for the database
- SYSADM or SYSCTRL authority
- System DBADM
- Installation SYSOPR authority (when the current SQLID of the process is set to SYSINSTL)

If the database is implicitly created, the database privileges must be on the implicit database or on DSNDB04.

The privilege set must include SECADM authority if one of the following clauses is specified:

- ACTIVATE
- DEACTIVATE

Additional privileges might be required in the following situations:

- FOREIGN KEY, ADD PRIMARY KEY, ADD UNIQUE, DROP PRIMARY KEY, DROP FOREIGN KEY, or DROP CONSTRAINT is specified.

- The data type of a column that is added to the table is a distinct type.
- A fullselect is specified.
- A column is defined as a security label column.
- A column is defined as ROWID GENERATED BY DEFAULT.

See the description of the appropriate clauses for the details about these privileges.

Privilege set: If the statement is embedded in an application program, the privilege set is the privileges that are held by the owner of the package. If the statement is dynamically prepared, the privilege set is the union of the privilege sets that are held by each authorization ID and role of the process.

Syntax for ALTER TABLE

➔ ALTER TABLE — *table-name* ➔

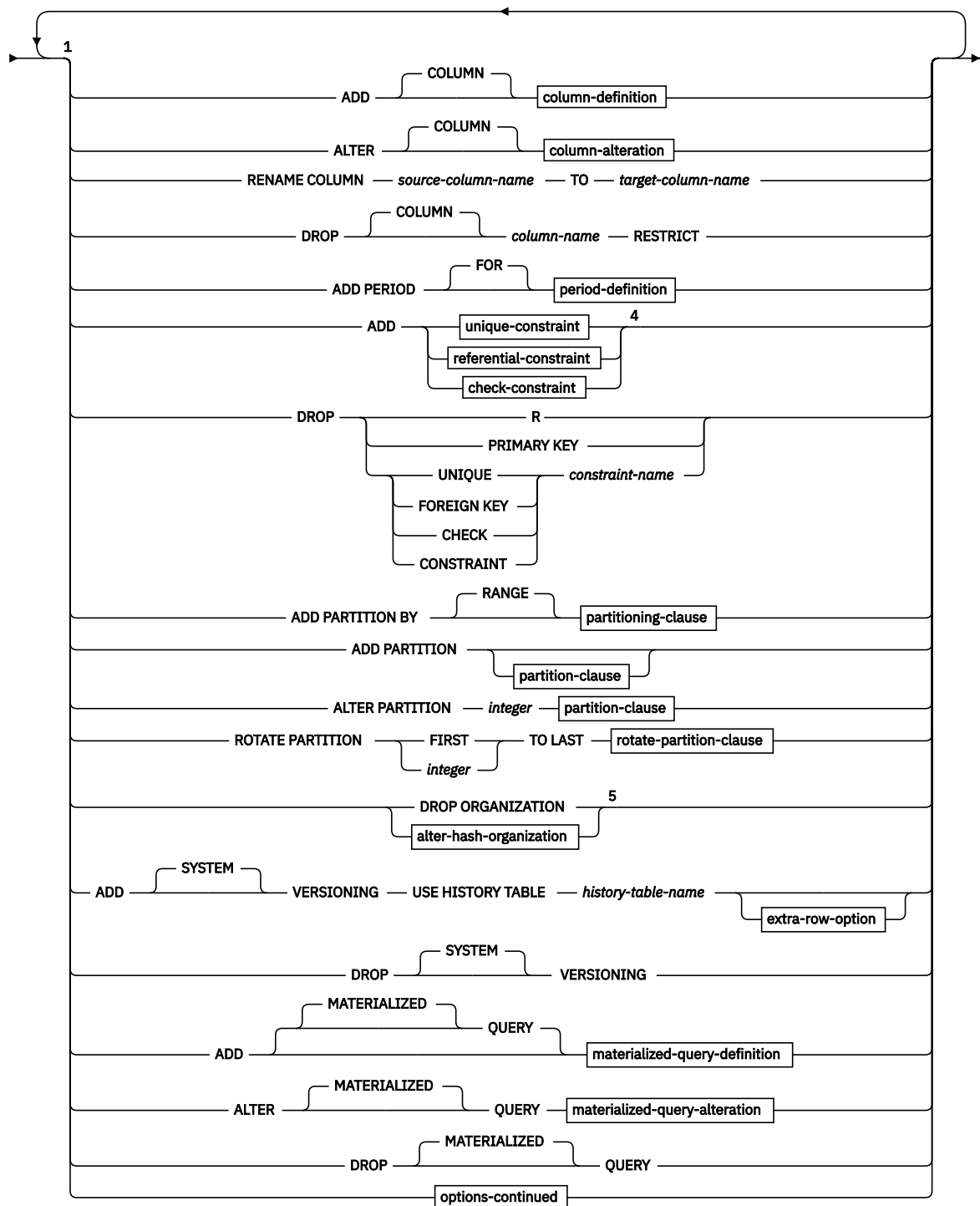

Notes:

- ¹ The same clause must not be specified more than one time, except for the ADD COLUMN or ALTER COLUMN clauses. If multiple ADD COLUMN clauses are specified in the same statement, at most one ADD COLUMN clause can contain a *references-clause*. If ALTER COLUMN SET DATA TYPE is specified, it must be specified first.
- ² The ADD PARTITION and ALTER PARTITION clauses can be specified together only when adding a new partition between existing logical partitions. Otherwise, the ALTER COLUMN, ADD PARTITION, ALTER PARTITION, and ROTATE PARTITION clauses are mutually exclusive with each other.

³ If ADD CLONE, DROP CLONE, RENAME COLUMN, ALTER ORGANIZATION, DROP ORGANIZATION, ADD VERSIONING, DROP VERSIONING, DROP COLUMN, ACTIVATE, DEACTIVATE, ENABLE ARCHIVE, or DISABLE ARCHIVE is specified, no other clause is allowed on the ALTER TABLE statement.

⁴ The ADD keyword is optional for *referential-constraint* or *unique-constraint* if it is the first clause specified in the statement. Otherwise, ADD is required.

⁵ FL 504 Hash-organized tables are deprecated. Beginning in Db2 12, packages bound with APPLCOMPAT(V12R1M504) or higher cannot create hash-organized tables or alter existing tables to use hash-organization. Existing hash organized tables remain supported, but they are likely to be unsupported in the future.

options-continued:

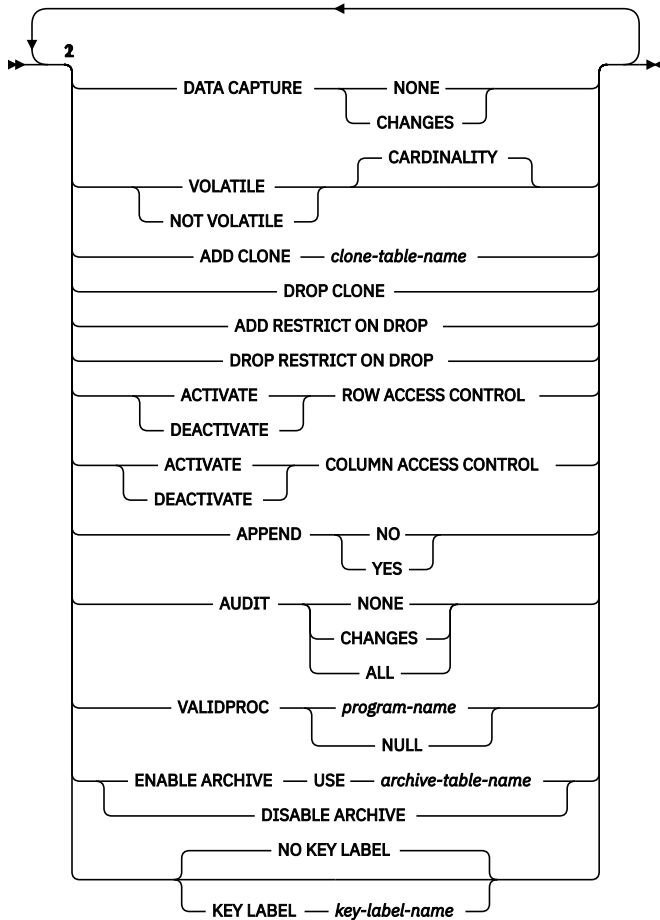

Notes:

¹ The same clause must not be specified more than one time, except for the ADD COLUMN or ALTER COLUMN clauses. If multiple ADD COLUMN clauses are specified in the same statement, at most one ADD COLUMN clause can contain a *references-clause*. If ALTER COLUMN SET DATA TYPE is specified, it must be specified first.

² If ADD CLONE, DROP CLONE, RENAME COLUMN, ALTER ORGANIZATION, DROP ORGANIZATION, ADD VERSIONING, DROP VERSIONING, DROP COLUMN, ACTIVATE, DEACTIVATE, ENABLE ARCHIVE, or DISABLE ARCHIVE is specified, no other clause is allowed on the ALTER TABLE statement.

column-definition:

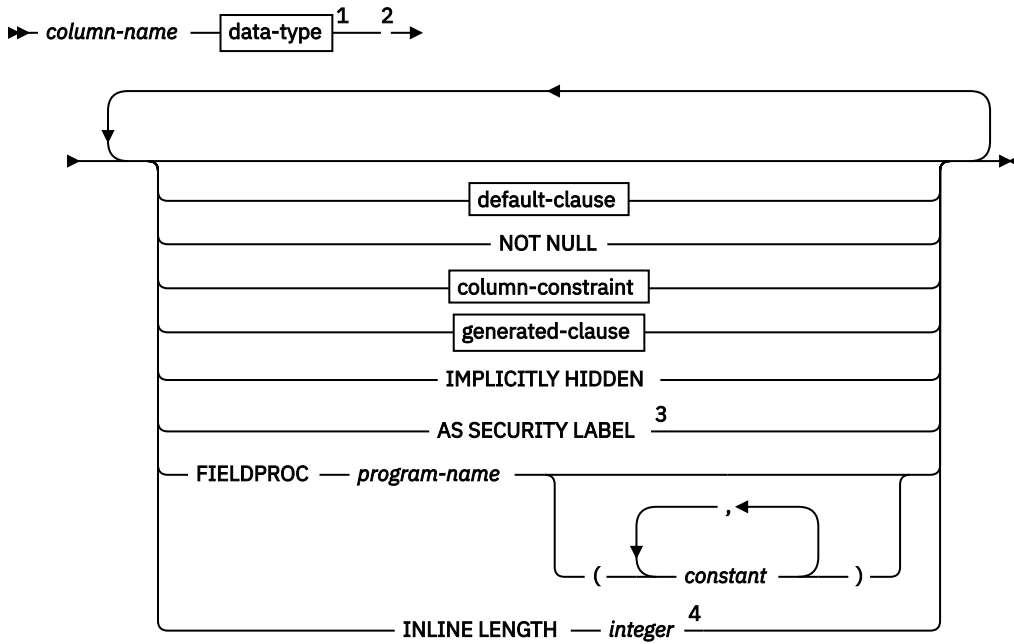

Notes:

- ¹ data-type is optional if as-row-change-timestamp-clause is specified.
- ² The same clause must not be specified more than one time.
- ³ AS SECURITY LABEL can be specified only for a CHAR(8) data type and requires that the NOT NULL and WITH DEFAULT clauses be specified.
- ⁴ INLINE LENGTH only applies to a column with a LOB data type or a distinct type that is based on a LOB data type.

data-type:

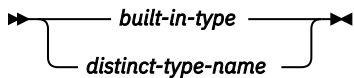

built-in-type:

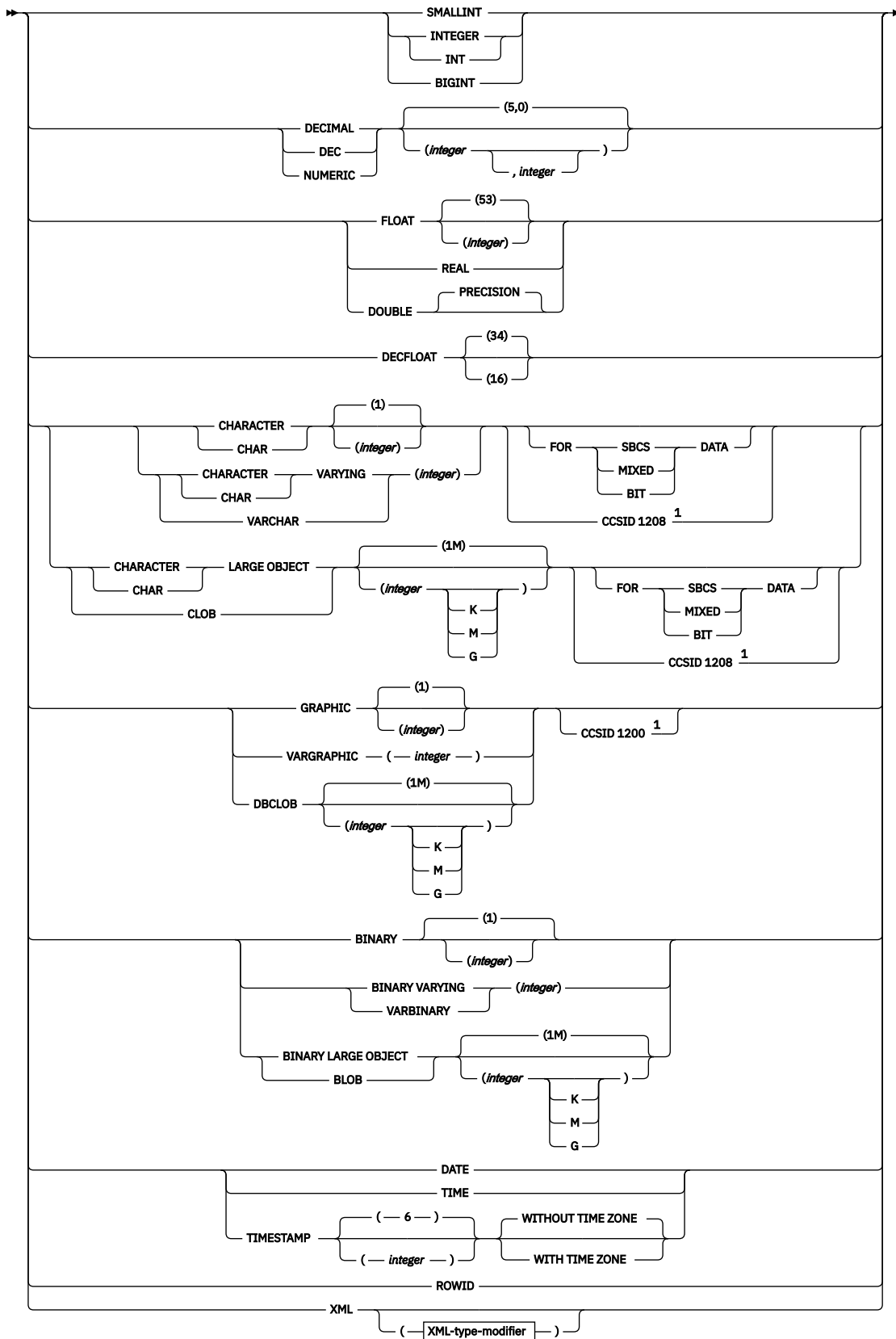

Notes:

¹ The CCSID clause must only be specified for a character string or graphic string column in an EBCDIC table when the ADD COLUMN clause is also specified.

XML-type-modifier:

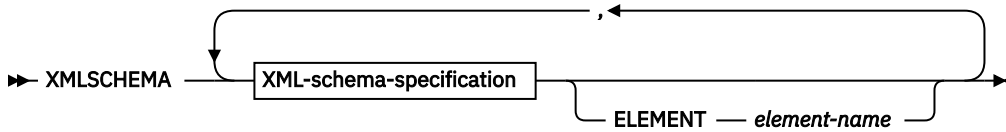

XML-schema-specification:

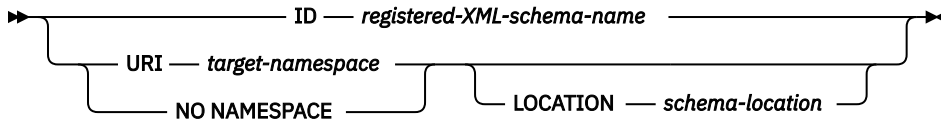

default-clause:

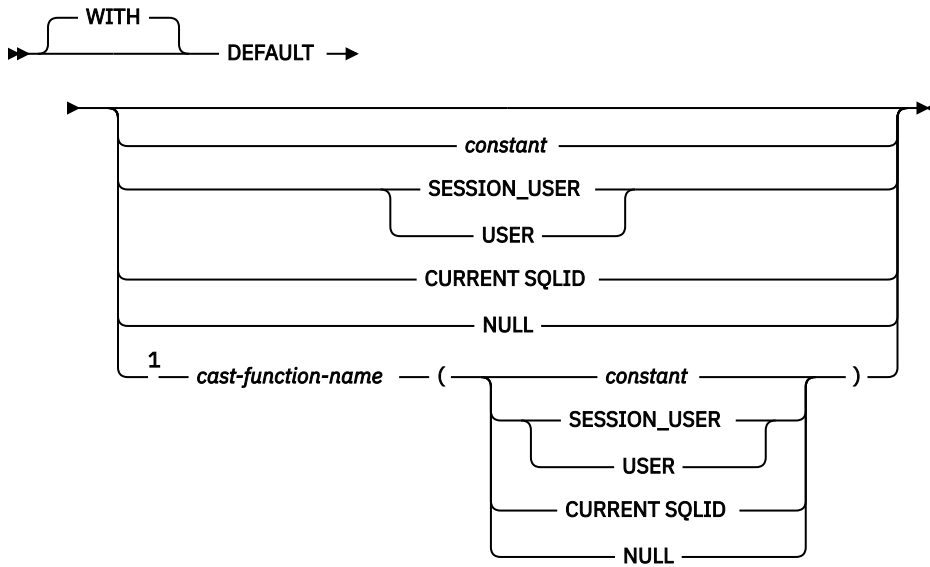

Notes:

¹ The *cast-function-name* form of the DEFAULT value can only be used with a column that is defined as a distinct type.

column-constraint

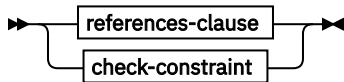

generated-clause:

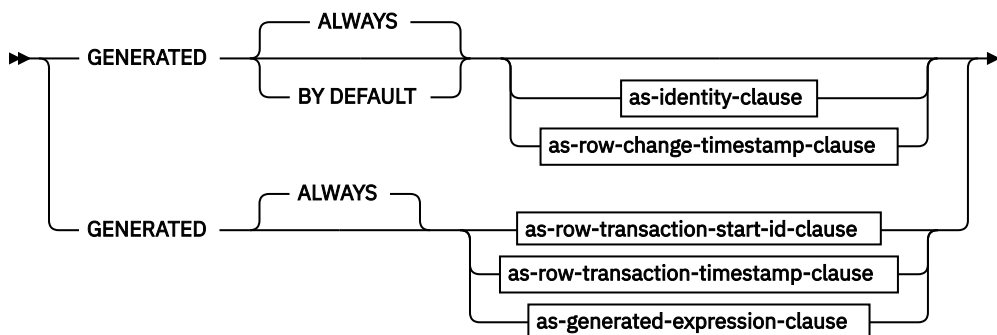

as-identity-clause:

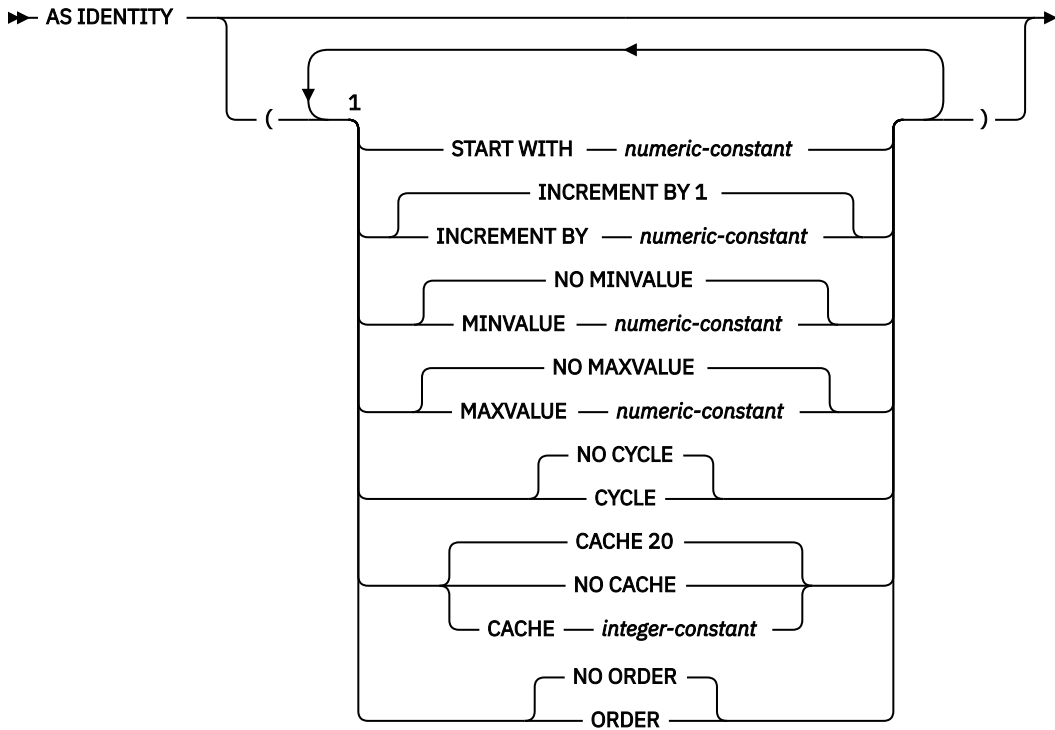

Notes:

¹ Separator commas can be specified between attributes when an identity column is defined.

as-row-change-timestamp-clause:

FOR EACH ROW ON UPDATE AS ROW CHANGE TIMESTAMP

as-row-transaction-start-id-clause:

AS TRANSACTION START ID

as-row-transaction-timestamp-clause:

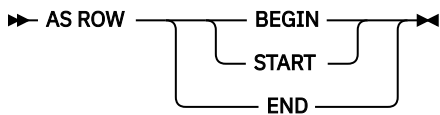

as-generated-expression-clause:

AS (non-deterministic-expression)

non-deterministic-expression:

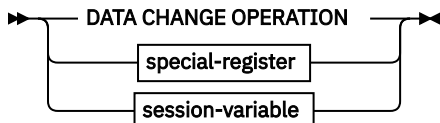

special-register:

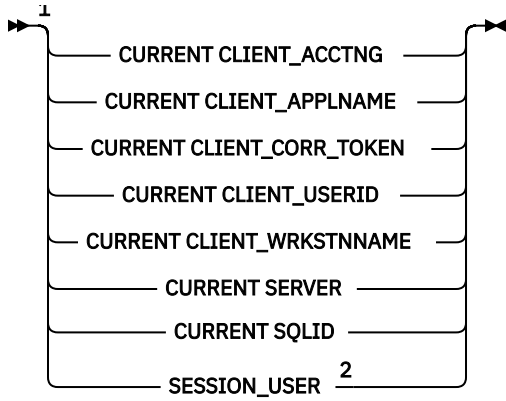

Notes:

- ¹ This definition of special register is specific to this context, as part of *non-deterministic-expression*.
- ² USER can be specified as a synonym for SESSION_USER.

session-variable:

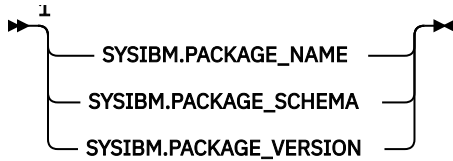

Notes:

- ¹ This definition of session variable is specific to this context, as part of *non-deterministic-expression*.

column-alteration:

→ *column-name* →

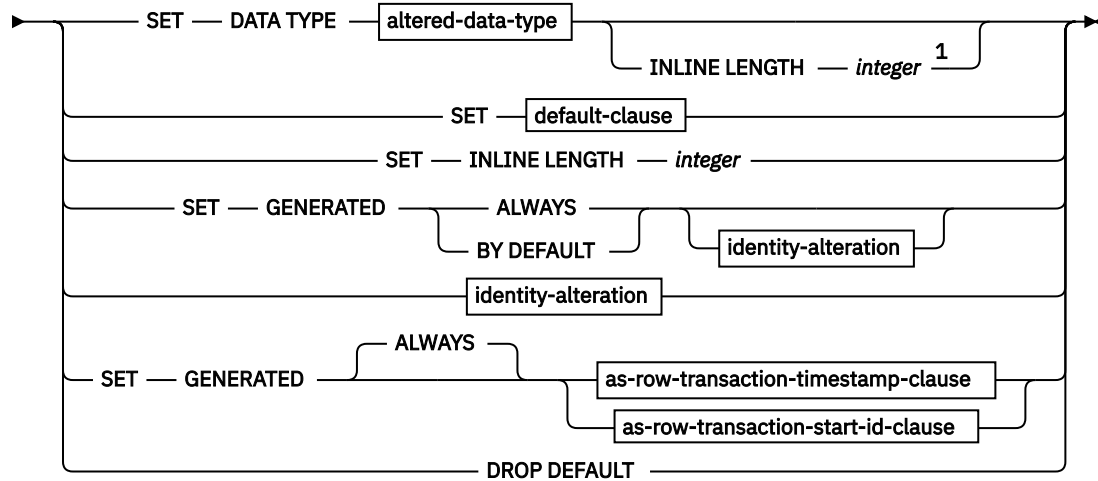

Notes:

- ¹ INLINE LENGTH can only be specified for LOB columns in tables that are in universal table spaces. INLINE LENGTH cannot be specified if FOR SBCS DATA or FOR MIXED DATA is also specified.

altered-data-type:

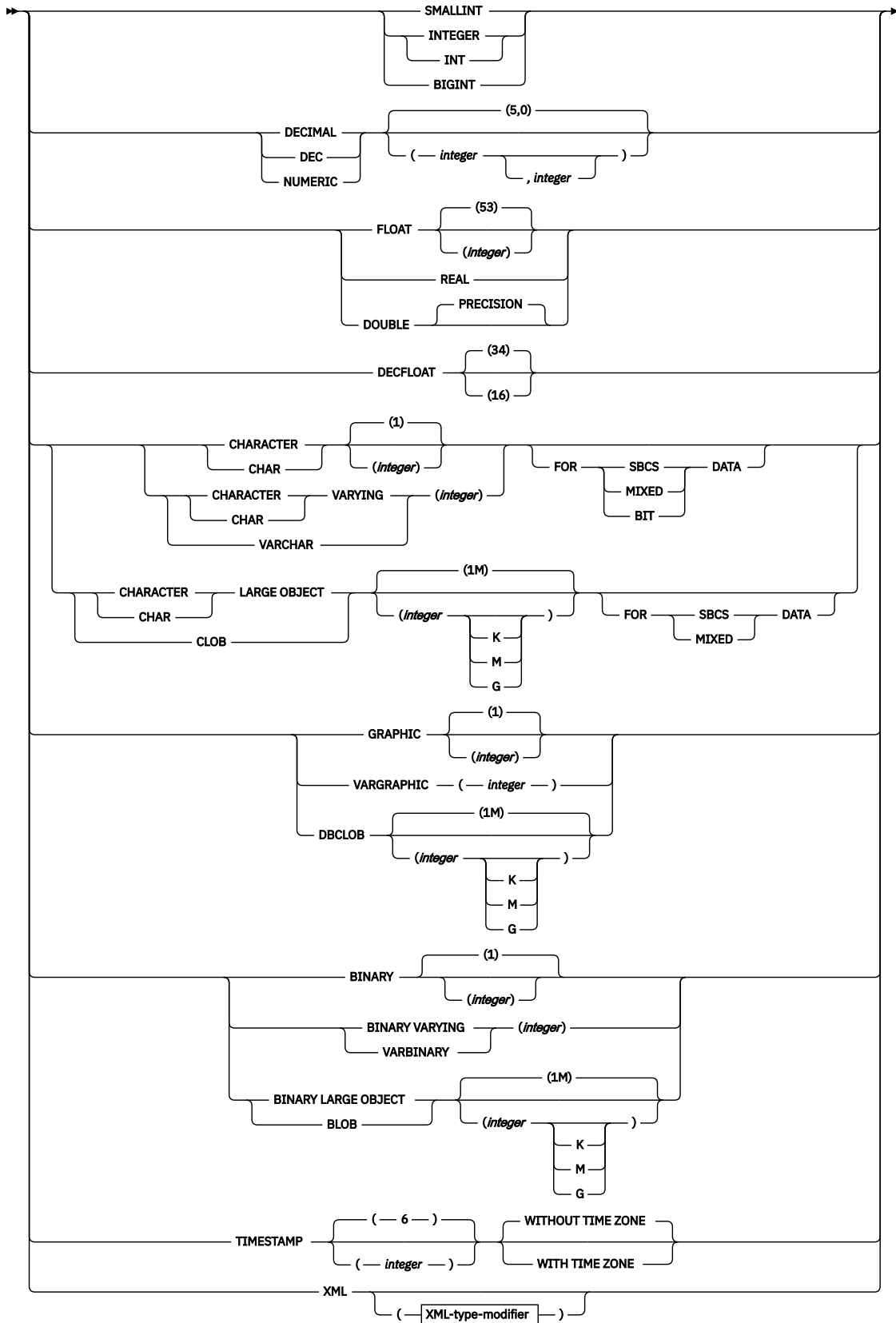

XML-type-modifier:

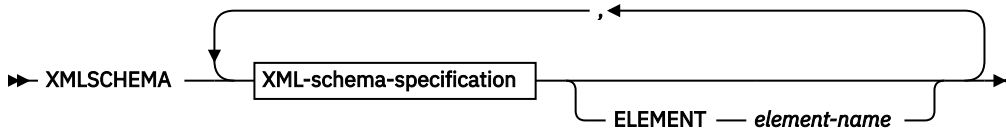

XML-schema-specification:

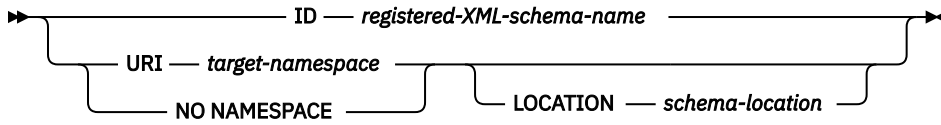

identity-alteration:

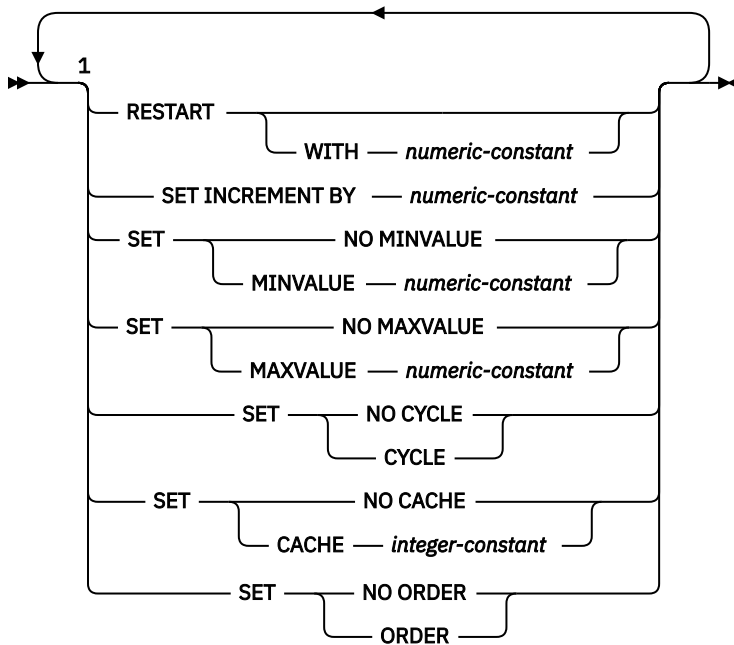

Notes:

¹ At least one option must be specified and the same clause must not be specified more than one time.

unique-constraint:

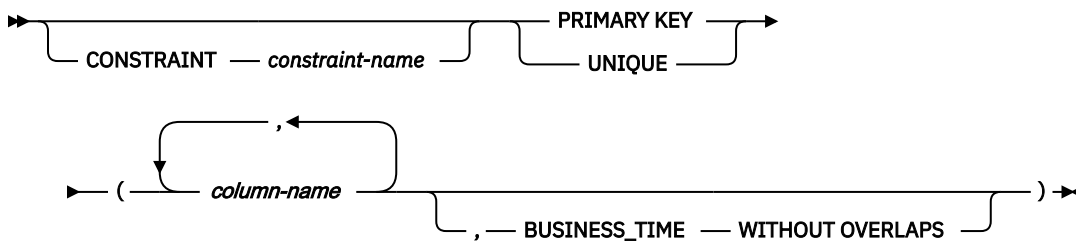

referential-constraint:

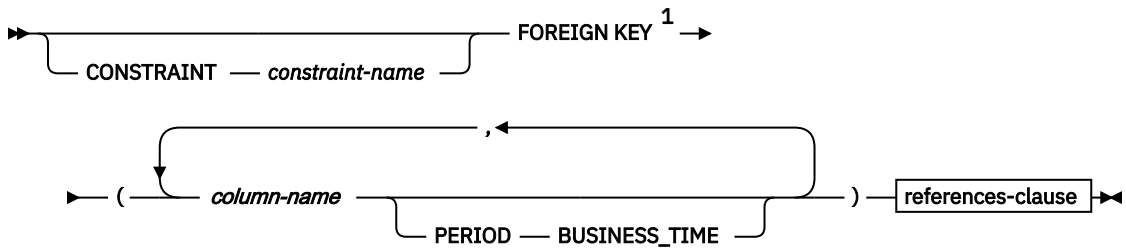

Notes:

¹ For compatibility with prior releases, when the CONSTRAINT clause (shown above) is not specified, a *constraint-name* can be specified following FOREIGN KEY.

references-clause:

REFERENCES — *parent-table-name* →

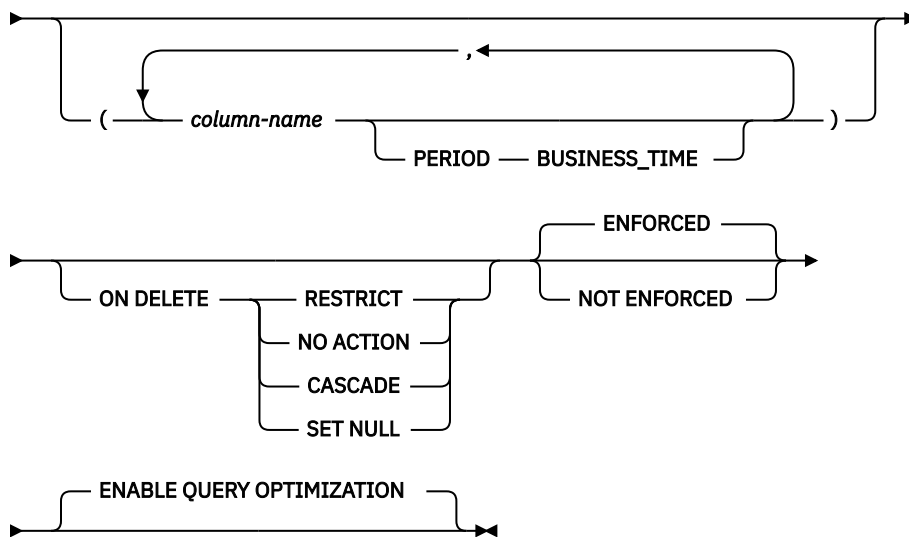

check-constraint:

CHECK — (*check-condition*) →

CONSTRAINT — *constraint-name*

partitioning-clause:

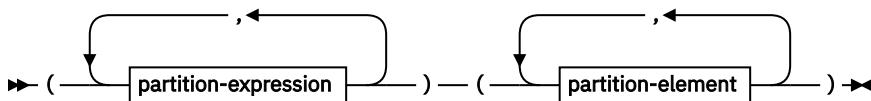

partition-expression:

column-name — NULLS LAST — { ASC } — { DESC }

partition-element:

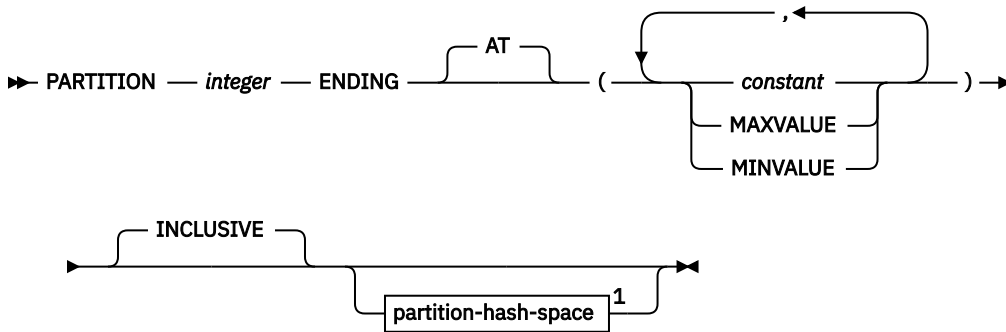

Notes:

¹ FL 504 Hash-organized tables are deprecated. Beginning in Db2 12, packages bound with APPLCOMPAT(V12R1M504) or higher cannot create hash-organized tables or alter existing tables to use hash-organization. Existing hash organized tables remain supported, but they are likely to be unsupported in the future.

partition-clause:

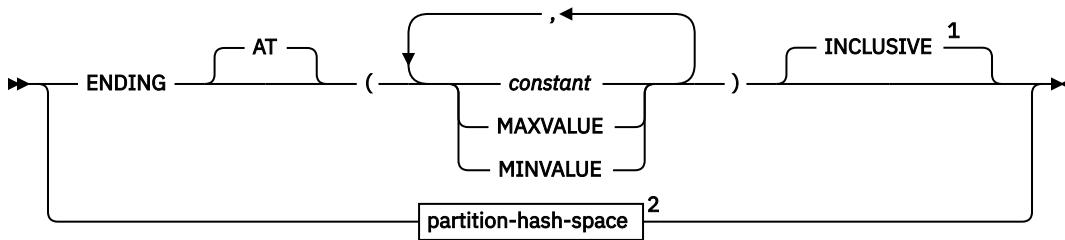

Notes:

¹ The ENDING clause must not be specified for a partition-by-growth table space, but must be specified for a range partitioned table space.

² FL 504 Hash-organized tables are deprecated. Beginning in Db2 12, packages bound with APPLCOMPAT(V12R1M504) or higher cannot create hash-organized tables or alter existing tables to use hash-organization. Existing hash organized tables remain supported, but they are likely to be unsupported in the future.

rotate-partition-clause:

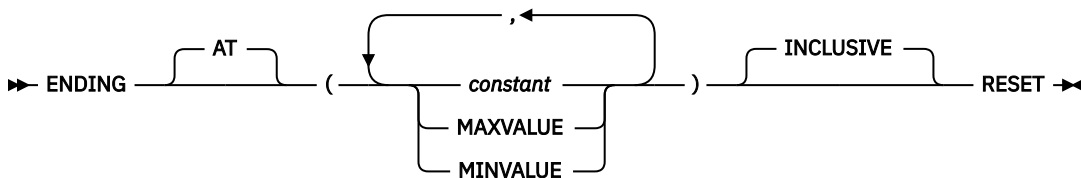

extra-row-option:

ON DELETE ADD EXTRA ROW

materialized-query-definition:

(— fullselect —) refreshable-table-options

refreshable-table-options:

▶▶ DATA INITIALLY DEFERRED — REFRESH DEFERRED →

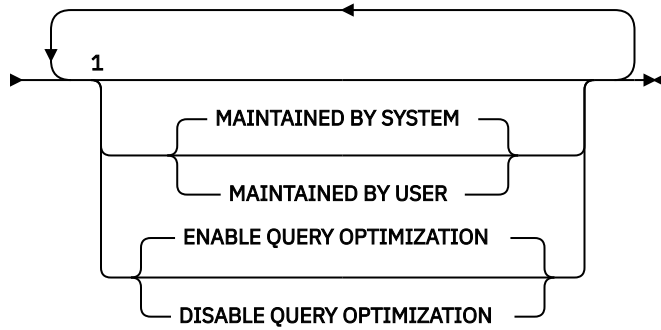

Notes:

¹ The same clause must not be specified more than one time.

materialized-query-table-alteration:

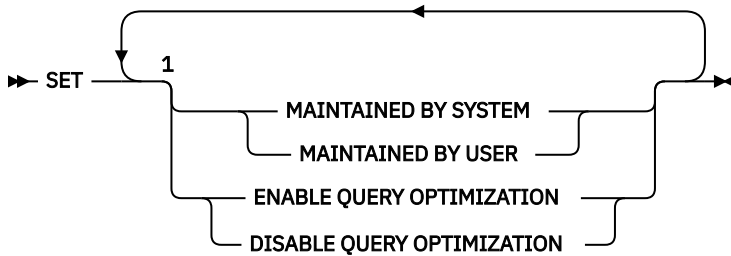

Notes:

¹ The same clause must not be specified more than one time.

period-definition:

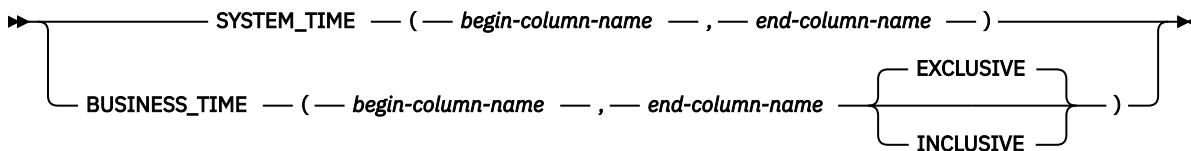

Description for ALTER TABLE

table-name

Identifies the table to be altered. The name must identify a table that exists at the current server. The name must not identify a declared temporary table, a directory table, a view, or a table that was implicitly created for an XML column. If the name identifies a catalog table, DATA CAPTURE CHANGES is the only clause that can be specified. If the name identifies an accelerator-only table, ADD RESTRICT ON DROP or DROP RESTRICT ON DROP are the only clauses that can be specified.

If *table-name* identifies an auxiliary table, alterations are limited to the following clauses:

- APPEND

If *table-name* identifies a materialized query table, alterations are limited to the following clauses:

- AUDIT
- DATA CAPTURE
- ALTER MATERIALIZED QUERY
- ALTER PARTITION
- DROP MATERIALIZED QUERY

- ADD RESTRICT ON DROP
- DROP RESTRICT ON DROP
- ROTATE PARTITION
- KEY LABEL
- NO KEY LABEL

FL 502 KEY LABEL *key-label-name* or NO KEY LABEL

Specifies whether key label is specified at the table level for encryption. For the changed KEY LABEL value to take effect, a subsequent REORG of the existing associated table spaces and index spaces is required. The *table-name* must identify a table that resides in a universal table space or a partitioned table space

KEY LABEL *key-label-name*

Specifies the default key label that is used to encrypt all the table spaces and index spaces associated with the table. This includes base table spaces, auxiliary table spaces, XML table spaces, index spaces, and table spaces for clone tables, regardless of whether it is explicitly or implicitly created. Users must set the key label for archive or history tables independently.

The data set must be Db2-managed for all the table spaces and index spaces associated with the table.

The *table-name* must not identify one of the following:

- A catalog table.
- A directory table.
- A clone table.
- An auxiliary table.
- A table that was implicitly created for an XML column.
- A created global temporary table.

The key label must be defined in ICSF. The Db2 address space RACF user ID or group must be permitted access to the key label in RACF.

The key label can be inherited or overridden when the data set is allocated. For details about the order of precedence, see [Determining a key label for base table space and associated objects](#).

NO KEY LABEL

Indicates that there is no key label specified at the table level for encryption. Any existing table level key label is removed.

ADD COLUMN

ADD COLUMN *column-definition*

Adds a column to the table. Except for the following columns, all values of the column in existing rows are set to its default value:

- ROWID column
- Identity column
- Row change timestamp column
- Row-begin column
- Row-end column
- Transaction-start-ID column

If the table has n columns, the ordinality of the new column is $n+1$. The value of n cannot be greater than 749. For a dependent table, n cannot be greater than 748.

The column cannot be added if the increase in the total byte count of the columns exceeds the maximum row size. The maximum row size for the table is eight less than the maximum record size as described in [Maximum record size](#).

If you add a LOB column and the table does not already have a ROWID column, Db2 creates an implicitly hidden ROWID column. For details about adding a LOB column, such as the other objects that might be implicitly created or need to be explicitly created, see [Creating a table with LOB columns](#). For more information about adding a ROWID column, see [Adding a ROWID column](#).

For implicitly created LOB objects, the privilege set requires CREATETAB and CREATETS privileges on the database that contains the table (DSNDB04 if the database is implicitly created) and the USE privilege on the buffer pool and the storage group that is used by the auxiliary table and the LOB table space. Implicitly created objects are owned by the owner of the base table.

If you add an XML column, the privilege set requires the CREATETAB and CREATETS privileges on the database that contains the table (DSNDB04 if the database is implicitly created), INDEX on the base table for the first DOCID column that is added, and USE privilege on the buffer pool and the storage group that is used by the XML objects. These privileges are required for implicitly created XML objects. Implicitly created objects are owned by the owner of the base table.

If you add an XML column to an existing table, the underlying XML table space is implicitly created according to the PAGENUM attribute of the associated base table. The DSSIZE value depends on the type of table space that contains the base table. For more information, see [XML table space implicit creation \(Db2 Administration Guide\)](#).

When you add a column to a table, the table space is placed in advisory REORG-pending (AREO*) status. However, if you add an identity column to a table that is not empty, the table space is placed in REORG-pending (REORP) status.

The table must not be a history table or archive table.

If the table is a system-period temporal table, the column is also added to the associated history table. If the table is an archive-enabled table, the column is also added to the associated archive table. The following attributes of the column in the associated table are the same as the attributes of the corresponding column of the table that is being altered:

- Name
- Data type
- Length (including inline LOB lengths), precision, scale
- FOR BIT, SBCS, or MIXED DATA attribute for a character string column
- Null attribute
- Hidden attribute
- Field procedure

You cannot add the following columns:

- A column to a table that has an edit procedure that is defined as WITH ROW ATTRIBUTES.
- A ROWID column to a table that already has an explicitly defined ROWID column
- An identity column to a table that has an identity column
- A security label column to a table that already has a security label column
- A security label column to a system-period temporal table or archive-enabled table
- A row change timestamp column to a table that already has a row change timestamp column
- A LOB, ROWID, identity column, or row change timestamp column to a created temporary table
- A GRAPHIC, VARGRAPHIC, DBCLOB, or CHAR FOR MIXED DATA column, in an EBCDIC or ASCII table, when the setting for installation option MIXED DATA is NO. An exception is that a Unicode column can be added to an EBCDIC table even when the installation option MIXED DATA is NO.

If the column that is being added is a security label column, row permissions, including the default row permission, cannot exist for the table

column-name

Names of the column you want to add to the table. The name must not be the same as the name of an existing column of the table or the name of a period in the table. A column named

SYSTEM_TIME or BUSINESS_TIME cannot be added to a table that is defined as a system-period temporal table or a history table. Do not qualify *column-name*.

data-type

Specifies the data type of the column. The data type can be a built-in data type or a distinct type.

built-in-type

Specifies that the data type of the column is one of the built-in data types. See [built-in-type](#) for information about the built-in data types that can be used when adding a column to a table.

distinct-type-name

Specifies the distinct type (user-defined data type) of the column. The length and scale of the column are respectively the length and scale of the source type of the distinct type. The privilege set must implicitly or explicitly include the USAGE privilege on the distinct type.

The encoding scheme of the distinct type must be the same as the encoding scheme of the table.

If the column is to be used in the definition of the foreign key of a referential constraint, the data type of the corresponding column of the parent key must have the same distinct type.

NOT NULL

Prevents the column from containing null values. If NOT NULL is specified, the DEFAULT clause must be used to specify a non-null default value for the column unless the column has a row ID data type or is an identity column. For a ROWID column, NOT NULL must be specified, and DEFAULT must not be specified. For an identity column, although NOT NULL can be specified, DEFAULT must not be specified.

DEFAULT

Specifies the default value that is assigned to the column in the absence of a value specified in a data change statement, or LOAD. Do not specify DEFAULT for the following types of columns:

- A ROWID column (Db2 generates default values)
- An identity column (Db2 generates default values)
- An XML column
- A row change timestamp column

Do not specify a value after the DEFAULT keyword for a security label column. Db2 provides the default for a security label column.

If a value is not specified after the DEFAULT keyword, the default value depends on the data type of the column:

Data Type

Default Value

Numeric

0

Fixed-length character or graphic string

Blanks

Fixed-length binary string

Hexadecimal zeros

Varying-length string

A string of length 0

Inline BLOB

Hexadecimal zeros

Inline CLOB

Blanks

Inline DBCLOB

Blanks

Date

For existing rows, a date corresponding to 1 January 0001. For added rows, CURRENT DATE.

Use of this clause or keyword might invalidate packages that depend on the target object, or packages that depend on related objects through cascading effects. See [Changes that invalidate packages \(Db2 Application programming and SQL\)](#).

Time

For existing rows, a time corresponding to 0 hours, 0 minutes, and 0 seconds. For added rows, CURRENT TIME.

Use of this clause or keyword might invalidate packages that depend on the target object, or packages that depend on related objects through cascading effects. See [Changes that invalidate packages \(Db2 Application programming and SQL\)](#).

Timestamp without time zone

For existing rows, a date corresponding to 1 January 0001, and a time corresponding to 0 hours, 0 minutes, 0 seconds, and zeros for fractional seconds up to the timestamp precision. For added rows, CURRENT_TIMESTAMP(*p*) WITHOUT TIME ZONE where *p* is the corresponding timestamp precision. Use of this clause or keyword might invalidate packages that depend on the target object, or packages that depend on related objects through cascading effects. See [Changes that invalidate packages \(Db2 Application programming and SQL\)](#).

Timestamp with time zone

For existing rows, a date corresponding to 1 January 0001, and a time corresponding to 0 hours, 0 minutes, 0 seconds, and zeros for fractional seconds up to the timestamp precision, 0 time zone hours, 0 time zone minutes. For added rows, CURRENT_TIMESTAMP(*p*) WITH TIME ZONE where *p* is the corresponding timestamp precision.

If the column is defined as timestamp with time zone, the default value must include a time zone.

Use of this clause or keyword might invalidate packages that depend on the target object, or packages that depend on related objects through cascading effects. See [Changes that invalidate packages \(Db2 Application programming and SQL\)](#).

In a given column definition:

- DEFAULT and FIELDPROC cannot both be specified.
- NOT NULL and DEFAULT NULL cannot both be specified.
- Omission of NOT NULL and DEFAULT for a column other than an identity column is an implicit specification of DEFAULT NULL. For an identity column, it is an implicit specification of NOT NULL, and Db2 generates default values.

A default value other than the one that is listed above can be specified in one of the following forms:

- WITH DEFAULT for a default value of an empty string
- DEFAULT NULL for a default value of null

constant

Specifies a constant as the default value for the column. The value of the constant must conform to the rules for assigning that value to the column.

A character or string constant must be short enough so that its UTF-8 representation requires no more than 1536 bytes. A hexadecimal graphic string (GX) constant cannot be specified.

In addition, the length of the constant value cannot be greater than the INLINE LENGTH attribute for LOB columns.

SESSION_USER or USER

Specifies the value of the SESSION_USER (USER) special register at the time of an SQL data change statement or LOAD, as the default for the column. If SESSION_USER is specified,

the data type of the column must be a character string with a length attribute greater than or equal to 8 characters when the value is expressed in CCSID 37. If the data type of the column is an inline CLOB, the INLINE LENGTH attribute must be greater than or equal to 8 characters when the value is expressed as CCSID 37. For existing rows, the value is that of the SESSION_USER special register at the time the ALTER TABLE statement is processed.

CURRENT SQLID

Specifies the value of the SQL authorization ID of the process at the time of an SQL data change statement or LOAD, as the default for the column. If CURRENT SQLID is specified, the data type of the column must be a character string with a length attribute greater than or equal to the length attribute of the CURRENT SQLID special register. If the data type of the column is an inline CLOB, the INLINE LENGTH attribute must be greater than or equal to the length attribute of the CURRENT SQLID special register. For existing rows, the value is the SQL authorization ID of the process at the time the ALTER TABLE statement is processed.

NULL

Specifies null as the default value for the column.

cast-function-name

The name of the cast function that matches the name of the distinct type for the column. A cast function can be specified only if the data type of the column is a distinct type.

The schema name of the cast function, whether it is explicitly specified or implicitly resolved through function resolution, must be the same as the explicitly or implicitly specified schema name of the distinct type.

constant

Specifies a constant as the argument. The constant must conform to the rules of a constant for the source type of the distinct type. The length of the constant cannot be greater than the INLINE LENGTH attribute for LOB columns.

SESSION_USER or USER

Specifies the value of the SESSION_USER (USER) special register at the time a row is inserted as the default for the column. The source type of the distinct type of the column must be a CHAR, VARCHAR, or inline CLOB with a length attribute (inline length attribute for CLOB) that is greater than or equal to the length attribute of the SESSION_USER special register.

CURRENT SQLID

Specifies the value of the CURRENT SQLID special register at the time a row is inserted as the default for the column. The source type of the distinct type of the column must be a CHAR, VARCHAR, or inline CLOB with a length attribute (or inline length attribute for CLOB) that is greater than or equal to the length attribute of the CURRENT SQLID special register.

NULL

Specifies the NULL value as the argument.

GENERATED

Specifies that Db2 generates values for the column.

GENERATED is applicable only to the following columns:

- ROWID columns
- Identity columns
- Row change timestamp columns
- Row-begin columns
- Row-end columns
- Transaction-start-ID columns
- Generated expression columns

If the table is a system-period temporal table or an archive-enabled table, GENERATED must not be specified for the column that is to be added, unless the column is a ROWID column. The default is GENERATED ALWAYS.

ALWAYS

Specifies that Db2 will generate a value for the column when a row is inserted into the table. ALWAYS is the recommended value unless you are using data propagation.

BY DEFAULT

Specifies that Db2 will generate a value for the column when a row is inserted unless a value was specified for the column on the data change statement.

If a user-supplied value is specified for a ROWID column, Db2 uses the value only if both of the following conditions are true:

- The value is a valid row ID value that was previously generated by Db2.
- The column has a unique, single-column index.

Until this index is created on the ROWID column, the insert, and update operations and the LOAD utility cannot be used to add rows to the table. If the table space name is not specified on the CREATE TABLE statement, Db2 implicitly creates the necessary object to make the table complete, including the index. The name of this index is 'I' followed by the first ten characters of the column name followed by seven randomly generated characters. If the column name is less than ten characters, Db2 adds underscore characters to the end of the name until it has ten characters. An implicitly created index has the COPY NO attribute.

For an identity column, Db2 inserts a specified value but does not verify that it is a unique value for the column unless the identity column has a unique, single-column index.

If a user-supplied value is specified for an identity column, Db2 inserts the specified value but does not perform any special validation on that value beyond the normal validation that is performed for any column. Db2 does not check how the specified value affects the sequential properties that are defined for the identity column. To ensure the uniqueness of an identity column that is defined as GENERATED BY DEFAULT, define a unique index on the identity column.

BY DEFAULT is the recommended value only when you are using data propagation.

AS IDENTITY

Specifies that the column is an identity column for the table. A table can have only one identity column. AS IDENTITY can be specified only if the data type for the column is an exact numeric type with a scale of zero (SMALLINT, INTEGER, BIGINT, DECIMAL with a scale of zero, or a distinct type that is based on one of these types). Separator commas between identity column attribute specifications are optional when the identity column is defined.

An identity column is implicitly NOT NULL. When adding an identity column to a table, you must also specify GENERATED ALWAYS or GENERATED BY DEFAULT.

Defining a column AS IDENTITY does not necessarily guarantee uniqueness of the values. To ensure uniqueness of the values, define a unique, single-column index on the identity column.

START WITH *numeric-constant*

Specifies the first value that is generated for the identity column. The value can be any positive or negative value that could be assigned to the column without non-zero digits existing to the right of the decimal point.

If a value is not explicitly specified when the identity column is defined, the default is the MINVALUE for an ascending identity column and the MAXVALUE for a descending identity column. This value is not necessarily the value that would be cycled to after reaching the maximum or minimum value for the identity column. The range used for cycles is defined by MINVALUE and MAXVALUE. MAXVALUE and MINVALUE do not constrain the *numeric-constant* value. That is, the START WITH clause can be used to start the generation of values outside the range that is used for cycles. For a description of the resulting behavior, see [“Specifying START or RESTART WITH values outside the range for cycles for identity columns”](#) on page 1298.

INCREMENT BY *numeric-constant*

Specifies the interval between consecutive values of the identity column. The value can be any positive or negative value (including 0) that does not exceed the value of a large integer constant and can be assigned to the column without any non-zero digits to the right of the decimal point. The default is 1.

If the value is positive or zero, the sequence of values for the identity column ascends. If the value is negative, the sequence of values descends.

MINVALUE or NO MINVALUE

Specifies the minimum value at which a descending identity column either cycles or stops generating values or an ascending identity column cycles to after reaching the maximum value.

NO MINVALUE

Specifies that the minimum end point of the range of values for the identity column is not set. In this case, the default value for MINVALUE becomes one of the following values:

- For an ascending identity column, the value is the START WITH value or 1 if START WITH was not specified.
- For a descending identity column, the value is the minimum value of the data type of the column.

MINVALUE *numeric-constant*

Specifies the numeric constant that is the minimum value that is generated for this identity column. This value can be any positive or negative value that can be assigned to this column without non-zero digits to the right of the decimal point. The value must be less than or equal to the maximum value.

MAXVALUE or NO MAXVALUE

Specifies the maximum value at which an ascending identity column either cycles or stops generating values or a descending identity column cycles to after reaching the minimum value.

NO MAXVALUE

Specifies that the minimum end point of the range of values for the identity column is not set. In such a case, the default value for MAXVALUE becomes one of the following values:

- For an ascending identity column, the value is the maximum value of the data type of the column.
- For a descending identity column, the value is the START WITH value or -1 if START WITH is not specified.

MAXVALUE *numeric-constant*

Specifies the numeric constant that is the maximum value that is generated for this identity column. This value can be any positive or negative value that can be assigned to this column without non-zero digits to the right of the decimal point. The value must be greater than or equal to the minimum value.

CYCLE or NO CYCLE

Specifies whether this identity column is to continue to generate values after reaching either its maximum or minimum value.

NO CYCLE

Specifies that values will not be generated for the identity column after the maximum or minimum value has been reached. NO CYCLE is the default.

CYCLE

Specifies that values continue to be generated for this column after the maximum or minimum value has been reached. If this option is used, after an ascending identity column reaches the maximum value, it generates its minimum value. After

a descending identity column reaches its minimum value, it generates its maximum value. The maximum and minimum values for the identity column determine the range that is used for cycling.

When CYCLE is in effect, duplicate values can be generated by Db2 for an identity column. However, if a unique index exists on the identity column and a non-unique value is generated for it, an error occurs.

CACHE or NO CACHE

Specifies whether to keep some preallocated values in memory. Preallocating and storing values in the cache improves the performance of inserting rows into a table. The default is CACHE 20.

In a non-data sharing environment, if the system is shut down (either normally or through a system failure), all cached sequence values that have not been used in committed statements are lost (that is, they will never be used). The value specified for the CACHE option is the maximum number of sequence values that could be lost when the system is shut down.

In a data sharing environment, you can use the CACHE and NO ORDER options to allow multiple Db2 members to cache sequence values simultaneously.

NO CACHE

Specifies that values for the identity column are not preallocated and stored in the cache, ensuring that values will not be lost in the case of a system failure. In this case, every request for a new value for the identity column results in synchronous I/O.

CACHE *integer-constant*

Specifies the maximum number of values of the identity column sequence that Db2 can preallocate and keep in memory.

During a system failure, all cached identity column values that are yet to be assigned might be lost and will not be used. Therefore, the value that is specified for CACHE also represents the maximum number of values for the identity column that could be lost during a system failure.

The minimum value is 2.

In a data sharing environment, you can use the CACHE and NO ORDER options to allow multiple Db2 members to cache sequence values simultaneously.

ORDER or NO ORDER

Specifies whether the identity column values must be generated in order of request. The default is NO ORDER.

In a non-data sharing environment, there is no guarantee that values are assigned in order across the entire server unless NO CACHE is also specified. ORDER applies only to a single-application process.

In a data sharing environment, if ORDER is specified, NO CACHE is implicitly set, even if CACHE integer-constant is specified.

NO ORDER

Specifies that the values do not need to be generated in order of request.

ORDER

Specifies that the values are generated in order of request. Specifying ORDER might disable the caching of values. ORDER applies only to a single-application process.

In a data sharing environment, if the CACHE and NO ORDER options are in effect, multiple caches can be active simultaneously, and the requests for identity values from different Db2 members might not result in the assignment of values in strict numeric order. For example, suppose that members DB2A and DB2B are using the identity column, DB2A gets the cache values 1 to 20, and DB2B gets the cache values 21 to 40. If DB2A requested a value first, then DB2B requested, and then DB2A again requested, the actual order of values that are

assigned would be 1,21,2 . Therefore, to guarantee that identity values are generated in strict numeric order among multiple Db2 members using the same identity column, specify the ORDER option.

FOR EACH ROW ON UPDATE AS ROW CHANGE TIMESTAMP

Specifies that the column is a timestamp and the values will be generated by Db2. Db2 generates a value for the column for each row as a row is inserted, and for any row for which any column is updated. The value that is generated for a row change timestamp column is a timestamp that corresponds to the time of the insert or update of the row. If multiple rows are inserted or updated with a single statement, the value of the row change timestamp column might be different for each row.

Adding a row change timestamp column to an existing table means that existing rows might be affected, and that an AREO* state might be set for the table space until a REORG is completed. For each existing row, a timestamp value is assigned for the new row change timestamp column.

If *data-type* is specified, it must be `TIMESTAMP WITHOUT TIME ZONE` with a precision of 6. You must specify `NOT NULL` with a row change timestamp column.

AS ROW BEGIN

Specifies that a timestamp value is assigned to the column whenever a row is inserted or any column in the row is updated. If the value of the `SYSIBM.TEMPORAL_LOGICAL_TRANSACTION_TIME` built-in global variable at the time of the insert or update is null, the value is generated using a reading of the time-of-day clock during execution of the first data change statement in the unit of work that requires a value to be assigned to a row-begin column or transaction-start-ID column in a table, or a row in a system-period temporal table is deleted. Otherwise, the row-begin column is assigned the value of the `SYSIBM.TEMPORAL_LOGICAL_TRANSACTION_TIME` built-in global variable at the time of the insert or update.

A *row-begin* column is intended to be used for a system-period temporal table.

A table can have only one *row-begin* column. If *data-type* is not specified, the column is defined as `TIMESTAMP(12) WITHOUT TIME ZONE`. If *data-type* is specified, it must be `TIMESTAMP(12) WITHOUT TIME ZONE` or `TIMESTAMP(12) WITH TIME ZONE`. If the column is defined as `TIMESTAMP WITH TIME ZONE`, the values are stored in UTC, with a time zone of `+00:00`. The column cannot have a `DEFAULT` clause, and must be defined as `NOT NULL`.

A *row-begin* column is not updatable.

A value for a row-begin column is composed of a `TIMESTAMP(9)` value that is unique per transaction per data sharing member followed by 3 digits that indicate the data sharing member number.

Related information

[“TEMPORAL_LOGICAL_TRANSACTION_TIME” on page 334](#)

AS ROW END

Specifies that a value for the data type of the column is assigned when a row is inserted or any column in the row is updated. The value that is assigned for a timestamp without time zone column is `TIMESTAMP '9999-12-30-00.00.00.000000000000'`. The value that is assigned for a timestamp with time zone column is `TIMESTAMP '9999-12-30.00.00.00.000000000000 +00:00'`.

A *row-end* column is intended to be used for a system-period temporal table.

For a table with system-period data versioning, when a row is deleted as the result of an update or delete operation, the value of the *row-end* column in the historical row reflects when the row was deleted. The value that is generated for the column in the historical row is a timestamp that corresponds to the most recent transaction start time that is associated with the transaction. If a row that is to be updated would result in a value for the *row-end* column that is less than or equal to the value for the corresponding *row-begin* column, the

timestamp value for the *row-end* column is adjusted. If multiple rows are deleted with a single SQL statement, the values for the column in the historical rows are the same.

A table can have only one *row-end* column. If *data-type* is not specified, the column is defined as `TIMESTAMP(12) WITHOUT TIME ZONE`. If *data-type* is specified, it must be `TIMESTAMP(12) WITHOUT TIME ZONE` or `TIMESTAMP(12) WITH TIME ZONE`. If the column is defined as `TIMESTAMP WITH TIME ZONE`, the values are stored in UTC, with a time zone of `+00:00`. The column cannot have a `DEFAULT` clause.

A *row-end* column is not updatable.

AS TRANSACTION START ID

Specifies that a timestamp value is assigned when the row is inserted or any column in the row is updated. If the value of the *row-begin* column is unique from *row-begin* column values that are generated for other transactions, the *row-begin* column value is assigned to the *transaction-start-ID* column. Otherwise, the value of the *transaction-start-ID* column is derived from the *row-begin* column value and adjusted to make it unique from *transaction-start-ID* column values that are generated for other transactions.

A *transaction-start-ID* column is intended to be used for a system-period temporal table.

A table can have only one *transaction-start-id* column. If *data-type* is not specified, the column is defined as `TIMESTAMP(12) WITHOUT TIME ZONE`. If *data-type* is specified, it must be `TIMESTAMP(12) WITHOUT TIME ZONE` or `TIMESTAMP(12) WITH TIME ZONE`. If the column is defined as `TIMESTAMP WITH TIME ZONE`, the values are stored in UTC, with a time zone of `+00:00`. The column cannot have a `DEFAULT` clause.

A *transaction-start-id* column is not updatable.

as-generated-expression-clause

Specifies that values for the column are generated by Db2. The generated value is assigned to the column whenever a row is inserted, or any column in the row is updated.

DATA CHANGE OPERATION

Specifies that the database manager generates one of the following values, depending on the data change statement that changes the row:

I

Insert operation

U

Update operation.

D

Delete operation.

A table can have only one `DATA CHANGE OPERATION` column. The column must be defined as `CHAR(1)`. The column cannot have a `DEFAULT` clause and must not be defined as `NOT NULL`.

The column is a non-deterministic generated expression column.

Do not specify any of the following clauses for the column:

- `CCSID 1200`
- `CCSID 1208`
- `FIELDPROC`

special-register

Specifies the value of the special register. This column is to contain the value of the special register at the time of the data change statement that assigns the value to the column. If multiple rows are inserted or updated with a single SQL statement, the value for the column is the same for all of the rows.

special-register must be one of the following special registers, and the column must use the required data type.

Table 176. Possible special register values for non-deterministic generated expression columns

Special register	Data type for the column
CURRENT CLIENT_ACCTNG	VARCHAR(255)
CURRENT CLIENT_APPLNAME	VARCHAR(255)
CURRENT CLIENT_CORR_TOKEN	VARCHAR(255)
CURRENT CLIENT_USERID	VARCHAR(255)
CURRENT CLIENT_WRKSTNNAME	VARCHAR(255)
CURRENT SERVER	CHAR(16)
CURRENT SQLID	VARCHAR(n) where $n \geq 8$
SESSION_USER or USER	VARCHAR(128)

This column cannot have a DEFAULT clause and must not be defined as NOT NULL.

The column is a non-deterministic generated expression column.

Do not specify any of the following clauses for the column:

- CCSID 1200
- CCSID 1208
- FIELDPROC

For more information, see [“Special registers”](#) on page 177.

session-variable

Specifies the value of a built-in session variable. The fully qualified name of the session variable must be specified. The value of the session variable is obtained from the GETVARIABLE function at the time of the data change operation that assigns the value to the column. If multiple rows are changed with a single SQL statement, the value for the column is the same for all of the rows.

session-variable must be one of the following session variables, and the column must use the required data type.

Table 177. Possible session variable values for non-deterministic generated expression columns

Session variable	Data type for the column
SYSIBM.PACKAGE_NAME	VARCHAR(128)
SYSIBM.PACKAGE_SCHEMA	VARCHAR(128)
SYSIBM.PACKAGE_VERSION	VARCHAR(122)

The column cannot have a DEFAULT clause and must not be defined as NOT NULL.

The column is a non-deterministic generated expression column.

Do not specify any of the following clauses for the column:

- CCSID 1200
- CCSID 1208
- FIELDPROC

For more information, see [“Built-in session variables”](#) on page 336.

IMPLICITLY HIDDEN

Specifies that the column is not visible in the results of SQL statements unless you refer explicitly to the column by name. For example, assume that table T1 includes a column that is defined with the IMPLICITLY HIDDEN clause. The result of `SELECT * FROM T1` would not include the implicitly hidden column. However, the result of a SELECT statement that explicitly refers to the name of the implicitly hidden column would include that column in the result table.

IMPLICITLY HIDDEN must not be specified for a column that is defined as a ROWID, or a distinct type that is based on a ROWID.

column-constraint

Provides a shorthand method of defining a constraint composed of a single column. If a *column-constraint* is specified in the definition of column C, the effect is the same as if that constraint were specified as a *unique-constraint*, *referential-constraint*, or *check-constraint* in which column C is the only identified column.

references-clause

The *references-clause* of a *column-definition* provides a shorthand method of defining a foreign key composed of a single column. Thus, if *references-clause* is specified in the definition of column C, the effect is the same as if that *references-clause* were specified as part of a FOREIGN KEY clause in which C is the only identified column.

Do not specify *references-clause* in the definition of the following types of columns because these types of columns cannot be a foreign key:

- LOB columns
- ROWID columns
- XML columns
- DECFLOAT columns
- Row change timestamp columns
- Security label columns

check-constraint

The *check-constraint* of a *column-definition* has the same effect as specifying a check constraint in a separate *ADD check-constraint* clause. For conformance with the SQL standard, a check constraint specified in the definition of column C should not reference any columns other than C.

Do not specify a check constraint in the definition of the following types of columns:

- LOB columns
- ROWID columns
- XML columns
- DECFLOAT columns
- Security label columns

AS SECURITY LABEL

Specifies that the table is defined with multilevel security with row level granularity and specifies that the column will contain the security label values. A table can have only one security label column. To define a table with a security label column, the primary authorization ID of the statement must have a valid security label, and the RACF SECLABEL class must be active. In addition, the following conditions are also required:

- The data type of the column must be CHAR(8).
- The subtype of the column must be SBCS.
- The column does not have any field procedures, check constraints, or referential constraints.
- The column must be defined as NOT NULL and WITH DEFAULT clauses.

- The WITH DEFAULT clause must not be specified with a default value (Db2 provides the default value).
- The table does not have an edit procedure that is defined as WITH ROW ATTRIBUTES.
- The column must not be a Unicode column in an EBCDIC table.
- The table is not the source table for a materialized query table.

For existing rows in the table, the value of the security label column defaults to the security label of the user at the time the ALTER statement is executed.

FIELDPROC *program-name*

Designates *program-name* as the field procedure exit routine for the column. A field procedure can be specified only for a column with a length attribute that is not greater than 255 bytes. FIELDPROC can only be specified for columns that are a built-in character string or graphic string data types. The column must not be one of the following:

- a LOB column
- a security label column
- a row change timestamp column
- a column with the TIMESTAMP WITH TIME ZONE data type

The field procedure encodes and decodes column values. Before a value is inserted in the column, it is passed to the field procedure for encoding. Before a value from the column is used by a program, it is passed to the field procedure for decoding. A field procedure could be used, for example, to alter the sorting sequence of values entered in the column.

The field procedure is also invoked during the processing of the ALTER TABLE statement. When so invoked, the procedure provides Db2 with the column's *field description*. The field description defines the data characteristics of the encoded values. By contrast, the information you supply for the column in the ALTER TABLE statement defines the data characteristics of the decoded values.

If you omit FIELDPROC, the column has no field procedure.

For more information, see [Field procedures \(Db2 Administration Guide\)](#).

constant

Is a parameter that is passed to the field procedure when it is invoked. A parameter list is optional. The *n*th parameter specified in the FIELDPROC clause on ALTER TABLE corresponds to the *n*th parameter of the specified field procedure. The maximum length of the parameter list is 255 bytes, including commas but excluding insignificant blanks and the delimiting parentheses.

INLINE LENGTH *integer*

Specifies the maximum length of the inline portion of a LOB column value. The inline portion is the portion that is stored in the base table space. INLINE LENGTH cannot be specified if the column is not a LOB column (or a distinct type that is based on a LOB), if the table is not in a universal table space, or if the table is an accelerator-only table.

For BLOB and CLOB columns, *integer* specifies the maximum number of bytes that are stored in the base table space for the column. *integer* must be in the range 0–32680 (inclusive) for a BLOB or CLOB column.

For a DBCLOB column, *integer* specifies the maximum number of double-byte characters that are stored in the table space for the column. *integer* must be in the range 0–16340 (inclusive) for a DBCLOB column.

If INLINE LENGTH is specified, the value of *integer* cannot be greater than the maximum length of the LOB column.

If the INLINE LENGTH clause is not specified, the maximum length of the LOB column depends on the following conditions:

- If a distinct type is not used or the distinct type that is used has been created without the INLINE LENGTH attribute, the LOB column will use the value of the LOB INLINE LENGTH

parameter on installation panel DSNTIPD as the default inline length when the value of LOB INLINE LENGTH does not exceed the maximum length of the LOB column. If the value of LOB INLINE LENGTH exceeds the maximum length of the LOB column, the maximum length is the inline length of this LOB column.

- If a distinct type that has been created with the INLINE LENGTH attribute is used, the LOB column inherits the inline length from the distinct type.

Regardless of how the length is determined, the inline length of the LOB cannot be greater than its maximum length.

Be aware that specifying the ADD COLUMN clause might affect subsequent requests to recover to a point in time. See [Point-in-time recovery \(Db2 Utilities\)](#) for information about possible restrictions, effects on recovery status, and other considerations.

ALTER COLUMN

ALTER COLUMN *column-alteration*

Alters the definition of an existing column, including the attributes of an existing identity column. Only the attributes specified are altered. Other attributes remain unchanged. Only future values of the column are affected by the changes made with an ALTER TABLE ALTER COLUMN statement.

The table being altered must not be in an incomplete state because of a missing unique index on a unique constraint (primary or unique key). An ALTER TABLE ALTER COLUMN statement might not be processed in the same unit of work as a data change statement. A column cannot be altered if any of the following conditions are true:

- The table has an edit procedure that is defined as WITH ROW ATTRIBUTES or a validation exit procedure
- The table is used in a materialized query table definition
- The table is a materialized query table
- The table is a system-period temporal table that is enabled for system-period data versioning
- The table is a history table
- The table is an archive-enabled table or an archive table
- The table is a created temporary table.
- There is an extended index that depends on that column
- The column is referenced in a field procedure
- The column is referenced in a referential constraint
- The column is referenced in a check constraint
- The column is referenced in the definition of a SYSTEM_TIME or BUSINESS_TIME period
- The column is defined as a *transaction-start-ID* column
- The column is defined as a security label column
- The column is defined as a row change timestamp column
- The column is a generated expression column.

Db2 11 Unicode columns in EBCDIC tables can only be altered to the same data type, length, and CCSID. Starting in Db2 12 at function level 500 or higher, this type of alteration converts Db2 11 Unicode columns to Db2 12 or later Unicode columns. For more information, see [“Unicode columns in EBCDIC tables”](#) on page 113.

You can modify all the attributes of an existing identity column, except for the data type of the column. To change the data type of an identity column, drop the table containing the column and recreate it. When the attributes of an identity column are altered, the column of the specified *column-name* must exist in the specified table and must have been defined with the IDENTITY attribute. To change an existing column that is not an identity column into an identity column, drop the table that contains the column and recreate it.

column-name

Identifies the column to be altered. The name must not be qualified and must identify an existing column in the table being altered when the ALTER statement is processed. The name must not identify a column that is being added in the same ALTER TABLE statement.

A column can only be referenced in one ALTER COLUMN clause in a single ALTER TABLE statement. However, that same column can be referenced multiple times for adding or dropping constraints in the same ALTER TABLE statement.

SET DATA TYPE *altered-data-type*

Specifies the new data type of the column to be altered. For a character column, you can also use the clause to change the definition of the subtype that is stored in the Db2 catalog and OBD.

The following restrictions apply to use of the SET DATA TYPE clause:

- The data type of a column cannot be altered if the column is an identity column or is part of a hash key.
- The existing data type of the column cannot be a ROWID, date, time, or distinct type.
- The new data type must be compatible with the existing data type of the column.
- When the source data type is a LOB, the target data type must be the same LOB data type. If the source data type is a LOB and the maximum length is altered, the new maximum length must be at least as large as the existing length attribute.
- If the column is a partitioning column, and the existing data type is CHAR or VARCHAR FOR BIT DATA, the new data type cannot be VARBINARY or BINARY.
- If the column is CHAR FOR BIT DATA, VARCHAR FOR BIT DATA, or BINARY, the new data type cannot be VARBINARY if the column is part of an index and is defined with the DESC attribute.
- If the column is a Unicode column, the new data type cannot specify FOR BIT DATA, FOR MIXED DATA, or FOR SBCS DATA.
- If *altered-data-type* is XML, the old data type of the altered column must also be XML.
- A row in a table with PAGENUM RELATIVE or in a table space with PAGENUM RELATIVE must have a minimum data size of 3 bytes. If an ALTER TABLE ALTER COLUMN results in row size that is less than the minimum size, it will not be valid.

For more information on the compatibility of data types, see [“Assignment and comparison” on page 143](#).

A TIMESTAMP column can only be altered to TIMESTAMP with a larger precision. A TIMESTAMP WITH TIME ZONE column can only be altered to TIMESTAMP WITH TIME ZONE with a larger precision. If the precision of a timestamp column is increased, the fractional seconds of existing data values are extended with zeros so that the number of fractional second digits matches the specified timestamp precision.

If any numeric data type is being converted to DECFLOAT, the ALTER statement will fail if there is a partitioning key, index, or a unique constraint on the column.

If the data type is a character or graphic string, the new length attribute must be at least as large as the existing length attribute of the column. If the data type is a numeric data type, the specified precision and scale must be at least as large as the existing precision and scale. If a decimal fraction is being converted to floating point, the ALTER statement will fail if there is a unique index or a unique constraint on the column.

If the specified column has a default value, the existing default value must represent a value that could be assigned to a column with the new data type in accordance with the rules for assignment. The default value is updated to reflect the new data type.

If the column is specified in an index, the new column length must not exceed the limit on an index size. For PADDED indexes, the sum of the length attributes of the columns must not be greater than $2000-n$, where n is the number of columns that can contain null values. For NOT PADDED indexes, the sum of the length attributes of the columns must not be greater than 2000

- $n - 2m - 3d$, where n is the number of nullable columns, m is the number of varying length columns, and d is the number of DECFLOAT columns.

If the column is specified in a primary key or a unique constraint, the change must not make the sum of the column length attributes of the identified columns and the begin and end columns of any identified periods exceed the permitted limit for the type of constraint.

The total byte count of columns after the alteration must not exceed the maximum row size. If the column is in the partitioning key, the new partitioning key cannot exceed $255-n$.

Table 178 on page 1261 shows the numeric data type alterations that are supported for SET DATA TYPE:

Table 178. Supported numeric data type alterations for SET DATA TYPE

From/To	SMALLINT	INTEGER	BIGINT	DECIMAL (q,t)	REAL	DOUBLE	DECFLOAT (16)	DECFLOAT (34)
SMALLINT	Y	Y	Y	(q-t)>4	Y	Y	Y	Y
INTEGER	N	Y	Y	(q-t)>9	N	Y	Y	Y
BIGINT	N	N	Y	(q-t)>18	N	N	N	Y
DECIMAL (p,s)	s=0 p<5	s=0 p<10	s=0 p<=19	q>=p (q-t)>=(p-s)	p<7	p<16	p<17	Y
DECFLOAT (16)	N	N	N	N	N	N	Y	Y
DECFLOAT (34)	N	N	N	N	N	N	N	Y
FLOAT (1-21)	N	N	N	N	Y	Y	Y	Y
FLOAT (22-53)	N	N	N	N	N	Y	Y	Y

Table 179 on page 1261 shows the character data type alterations that are supported for SET DATA TYPE:

Table 179. Supported character data type alterations for SET DATA TYPE ($x > =0$).

From/To	CHARACTER (n+x)	VARCHAR (n+x)	LONG VARCHAR	GRAPHIC (n+x)	VARGRAPHIC (n+x)	LONG VARGRAPHIC
CHARACTER(n)	Y	Y	N	N	N	N
VARCHAR(n)	Y	Y	N	N	N	N
LONG VARCHAR	N	Y	N	N	N	N
GRAPHIC(n)	N	N	N	Y	Y	N
VARGRAPHIC(n)	N	N	N	Y	Y	N
LONG VARGRAPHIC	N	N	N	N	Y	N

When a CHAR FOR BIT DATA or VARCHAR FOR BIT DATA column is converted to a BINARY or VARBINARY data type, and there is an index defined on that column, the index will be put in RBDP.

Table 180. Supported binary data type alterations for SET DATA TYPE ($x \geq 0$)

From/To	BINARY(n+x)	VARBINARY(n+x)
CHAR(n) FOR BIT DATA	Y	Y
VARCHAR(n) FOR BIT DATA	Y	Y
BINARY(n)	Y	Y
VARBINARY(n)	Y ¹	Y

Note: ALTER from VARBINARY to BINARY is not allowed when the column is part of a unique index.

Depending on the situation when this clause is specified, Db2 might process the ALTER statement as a *pending data definition change*, which means the current object definition and data do not reflect the alteration at the time that the statement is issued. Instead, the altered object is placed in an advisory REORG-pending (AREOR) state, and a subsequent reorganization of the altered object with an appropriate utility materializes the changes to the catalog and data. For more information, see [Pending data definition changes \(Db2 Administration Guide\)](#).

If the change takes effect immediately, and the alteration results in the generation of a new table version, the table space that contains the table that is being changed is left in an advisory REORG-pending (AREO*) status.

FOR subtype DATA

Alters the *subtype* of a character column. This clause does not change the data. The clause only updates the definition of the subtype as it is stored in the Db2 catalog and the OBD. The length and data type that are specified must match the existing length and data type of the column.

Only character strings are valid when subtype is BIT.

For more information on the subtype values (SBCS, MIXED, and BIT), see the subtype information under [built-in-type](#).

INLINE LENGTH integer

Specifies the new inline length for the column. **INLINE LENGTH** can only be specified for an inline LOB column in a table that is in a universal table space. **INLINE LENGTH** cannot be specified if **FOR SBCS DATA** or **FOR MIXED DATA** is also specified in the same ALTER TABLE statement. Inline LOB columns cannot be added to a table that is in a table space that has basic row format. The new length can be smaller or larger than the original length. *integer* is a value in the range 0–32680 bytes (inclusive) for a BLOB or CLOB column or in the range 0–16340 characters (inclusive) for a DBCLOB column. The inline length cannot be changed in the following cases:

- The LOB column is referenced in an expression-based index or a spatial index.
- If the column has a default value, the new inline length is less than the length of the default value for the column.
- The new inline length is greater than the maximum length of the LOB column.

When the base table space is not empty, increasing the length puts the table space in an advisory REORG-pending state, and decreasing the length puts the table space in a REORG-pending state.

No expression-based indexes can be created after the inline length is changed until the REORG utility is run on the base table space.

SET INLINE LENGTH integer

Specifies the new inline length for the column. **SET INLINE LENGTH** can only be specified for an inline LOB column in a table that is in a universal table space. **INLINE LENGTH** cannot be specified

if FOR SBCS DATA or FOR MIXED DATA is also specified in the same ALTER TABLE statement. Inline LOB columns cannot be added to a table that is in a table space that has basic row format. The new length can be smaller or larger than the original length. *integer* is a value in the range 0–32680 bytes (inclusive) for a BLOB or CLOB column or in the range 0–16340 characters (inclusive) for a DBCLOB column. The inline length cannot be changed in the following cases:

- The LOB column is referenced in an expression-based index or a spatial index.
- If the column has a default value, the new inline length is less than the length of the default value for the column.
- The new inline length is greater than the maximum length of the LOB column.

When the base table space is not empty, increasing the length puts the table space in an advisory REORG-pending state, and decreasing the length puts the table space in a REORG-pending state.

No expression-based indexes can be created after the inline length is changed until the REORG utility is run on the base table space.

SET default-clause

Specifies the new default value of the column to be altered. The new default value must conform to the current rules for assigning that value to the column. Existing rows will retain their current value. The new default value will be reflected only in the rows that are inserted after the alter.

The table must not be referenced by a view. The table must not be defined with the DATA CAPTURE CHANGES attribute when the subsystem parameter RESTRICT_ALT_COL_FOR_DCC is set to YES.

If the column is specified in a unique constraint (unique key or primary key) or unique index, the default value might be altered to the same value as an existing row of that column. However, subsequent data change operations will fail in the absence of a value specified for that column on the insert operation.

If the column was defined by ALTER TABLE with the ADD COLUMN clause, run the REORG utility for the containing table space before setting the default value.

For LOB columns, default values can be changed only for inline LOB. The length of the new default value cannot be greater than the inline length.

If an ALTER TABLE statement with an ADD COLUMN clause that specifies a default value is successful, you cannot request a subsequent point-in-time recovery to a time that precedes processing of the ALTER TABLE statement.

DROP DEFAULT

Drops the current default value of the column. For columns that are not nullable, the specified column must be defined with a default value. For columns that are nullable, the specified column cannot have a null default value. For columns that are nullable, the new default value is the null value.

The table that contains the specified column must not be referenced in a view. The table must not be defined with the DATA CAPTURE CHANGES attribute when the subsystem parameter RESTRICT_ALT_COL_FOR_DCC is set to YES.

Follow these steps to remove the default value for a column that was defined using ALTER TABLE with the ADD COLUMN clause:

1. Run the REORG utility or the UPDATE statement to reset the AREO* state:
 - Run the REORG utility on the table space that contains the table
 - If the table is in a universal table space and the table does not have row access control activated, run an UPDATE statement without the SKIP LOCKED DATA or WHERE clauses specified. The update operation must be done with a searched UPDATE statement and the expression in the SET clause cannot be a *scalar-fullselect* or a *row-fullselect*. An update operation within a SELECT statement will not reset the AREO* status.
2. Issue the ALTER TABLE statement that specifies the DROP DEFAULT clause

If the REORG is not done before the ALTER TABLE, or the UPDATE statement does not reset the AREO* statue, an error is returned for the ALTER TABLE statement.

If an ALTER TABLE statement with an ALTER COLUMN clause that specifies DROP DEFAULT is successful, you cannot request a subsequent point-in-time recovery to a time that precedes processing of the ALTER TABLE statement.

SET GENERATED

Specifies that Db2 generates values for the column. SET GENERATED can be specified to change the generation attribute for an existing identity column. The clause can also be specified to change an existing non-generated column into a *row-begin* column, a *row-end* column, or a *transaction-start-ID* column.

ALWAYS

Specifies that Db2 always generates a value for the column when a row is inserted or updated and a default value must be generated.

BY DEFAULT

Specifies that Db2 generates a value for the column when a row is inserted or updated and a default value must be generated, unless an explicit value is specified. For a row change timestamp column, Db2 inserts or updates a specified value but does not verify that it is a unique value for the column unless the row change timestamp column has a unique constraint or a unique index that solely specifies the row change timestamp column.

RESTART

Specifies the next value for the identity column, If *numeric-constant* is not specified, the sequence is restarted at the value that is specified implicitly or explicitly as the starting value when the identity column was originally created. RESTART does not change the original START WITH value.

WITH *numeric-constant*

Specifies that, when it is time to generate the next value for this identity column, *numeric-constant* will be used as the next value for the column. This value can be any positive or negative value (including 0) that could be assigned to this column without nonzero digits existing to the right of the decimal point. The range used for cycles is defined by MINVALUE and MAXVALUE. MAXVALUE and MINVALUE do not constrain the *numeric-constant* value. That is, the RESTART WITH clause can be used to start the generation of values outside the range that is used for cycles. For more information, see [“Specifying START or RESTART WITH values outside the range for cycles for identity columns”](#) on page 1298.

If RESTART is not specified, the sequence is not restarted. Instead, it resumes with the current values that are in effect for all the options after the ALTER statement is issued.

After an identity column is restarted or changed to allow cycling, sequence numbers might be duplicates of values generated previously.

SET INCREMENT BY *numeric-constant*

For a definition, see the description of [INCREMENT BY *numeric-constant*](#) for defining an identity column.

SET MINVALUE or NO MINVALUE

For a definition, see the description of [MINVALUE or NO MINVALUE](#) for defining an identity column.

SET MAXVALUE or NO MAXVALUE

For a definition, see the description of [MAXVALUE or NO MAXVALUE](#) for defining an identity column.

SET CYCLE or NO CYCLE

For a definition, see the description of [CYCLE or NO CYCLE](#) for defining an identity column.

SET CACHE or NO CACHE

For a definition, see the description of [CACHE or NO CACHE](#) for defining an identity column.

SET ORDER or NO ORDER

For a definition, see the description of [ORDER or NO ORDER](#) for defining an identity column.

Be aware that specifying the ALTER COLUMN clause might affect subsequent requests to recover to a point in time. For information about possible restrictions, effects on recovery status, and other considerations, see [Point-in-time recovery \(Db2 Utilities\)](#).

RENAME COLUMN

RENAME COLUMN *source-column-name* **TO** *target-column-name*

Renames the specified column. The names must not be qualified.

source-column-name

Identifies the column that is to be renamed. The name must identify an existing column of the table.

target-column-name

Specifies the new name for the column. The name must not identify a column that already exists in the table, or the name of a period that exists in the table.

You cannot rename a column if any of the following conditions apply:

- The column is referenced in a view
- The column is referenced in the expression of an index definition
- The column is referenced in the definition of a row permission or a column mask
- The column is referenced in an SQL table user-defined function
- The column has a check constraint defined
- The column has a field procedure defined
- The table has a trigger
- The table is a materialized query table or is referenced by a materialized query table
- The table has a valid procedure, or an edit procedure that is defined as WITH ROW ATTRIBUTES
- The table is a Db2 catalog table
- The table is a system-period temporal table or a history table
- The table is an archive-enabled table or an archive table

DROP COLUMN

DROP COLUMN *column-name*

Drops the identified column from the table. Any privileges that are associated with the column are revoked.

A column cannot be dropped if any of the following conditions are true:

- The containing table space is not a universal table space
- The table is a created global temporary table
- The table is a system-period temporal table
- The table is a history table
- The table is an archive-enabled table
- The table is an archive table
- The table has an edit procedure or a validation exit procedure
- The table contains check constraints
- The table is a materialized query table
- The table is referenced in a materialized query table definition
- The table definition is in an incomplete state
- The column is the only column of the table
- The column is referenced in the definition of a period

- The column is defined as a security label column
- The column is an XML column
- The column is a DOCID column
- The column is an implicitly generated hidden ROWID column
- The column is defined as ROWID GENERATED BY DEFAULT, and the table contains an implicitly generated hidden ROWID column
- The column is a ROWID column on which there is a dependent LOB column
- The column is part of the table partitioning key
- The column is part of the hash key
- A row contains less than the minimum data size of 3 bytes
- All of the remaining columns in the table are hidden
- A view depends on the column
- A view that is dependent on the table has INSTEAD OF triggers
- A trigger is defined on the table
- Any of the following objects are dependent on the table:
 - Extended indexes
 - Row permissions
 - Column masks
 - SQL table functions

column-name

Identifies the column that is to be dropped. The column name must not be qualified. The name must identify a column of the specified table.

If the column is a LOB column, any auxiliary tables that are associated with the column and the indexes on the auxiliary tables are also dropped. Any LOB table spaces that were implicitly created for the auxiliary tables are also dropped. If the column is the last LOB column in the table, any implicitly created ROWID column in the table is also dropped.

Depending on the situation when this clause is specified, Db2 might process the ALTER statement as a *pending data definition change*, which means the current object definition and data do not reflect the alteration at the time that the statement is issued. Instead, the altered object is placed in an advisory REORG-pending (AREOR) state, and a subsequent reorganization of the altered object with an appropriate utility materializes the changes to the catalog and data. For more information, see [Pending data definition changes \(Db2 Administration Guide\)](#).

Use of this clause or keyword might invalidate packages that depend on the target object, or packages that depend on related objects through cascading effects. See [Changes that invalidate packages \(Db2 Application programming and SQL\)](#).

RESTRICT

Specifies that the column cannot be dropped if any views, indexes, unique constraints, or referential constraints are dependent on the column.

Be aware that specifying the DROP COLUMN clause might affect subsequent requests to recover to a point in time. See [Point-in-time recovery \(Db2 Utilities\)](#) for information about possible restrictions, effect on recovery status, and other considerations.

ADD PERIOD:

ADD PERIOD FOR *period-definition*

Adds a period to the table.

The table must not be an archive-enabled table or an archive table.

begin-column-name must not be the same as *end-column-name*. The data type, precision, and scale for *begin-column-name* must be the same as for *end-column-name*.

SYSTEM_TIME(*begin-column-name*, *end-column-name*)

Names the period SYSTEM_TIME. The name must not identify an existing column in the table. A table can have only one SYSTEM_TIME period.

The *begin-column-name* must specify a *row-begin* column and the *end-column-name* must specify a *row-end* column. Both columns must be defined as GENERATED ALWAYS. A column mask or row permission must not be defined for the table.

BUSINESS_TIME(*begin-column-name*, *end-column-name*)

Names the period BUSINESS_TIME. The name must not identify an existing column in the table. A table can have only one BUSINESS_TIME period.

An implicit check constraint is generated to ensure the relationship of the value of *end-column-name* to the value of *begin-column-name* as follows:

- For an inclusive-exclusive BUSINESS_TIME period, the value of *end-column-name* is greater than the value of *begin-column-name*.
- For an inclusive-inclusive BUSINESS_TIME period, the value of *end-column-name* is greater than or equal to the value of *begin-column-name*.

The name of the implicitly created check constraint is DB2_GENERATED_CHECK_CONSTRAINT_FOR_BUSINESS_TIME, and that name must not be defined as the name of an existing check constraint.

The columns that are specified for *begin-column-name* and *end-column-name* must be defined as DATE or TIMESTAMP(6) WITHOUT TIME ZONE, and must be defined as NOT NULL. The columns that are specified for *begin-column-name* and *end-column-name* must not identify a column that is defined with a GENERATED clause.

Use of this clause or keyword might invalidate packages that depend on the target object, or packages that depend on related objects through cascading effects. See [Changes that invalidate packages \(Db2 Application programming and SQL\)](#).

begin-column-name

Identifies the column that records the start value for the period. The name must identify an existing column in the table. *begin-column-name* must not be the same as a column that is used in the definition of another period for the table.

end-column-name

Identifies the column that records the end value for the period. The name must identify an existing column in the table. *end-column-name* must not be the same as a column that is used in the definition of another period for the table.

EXCLUSIVE

Specifies that the value of the end column is not included in the period. The BUSINESS_TIME period is defined as inclusive-exclusive.

INCLUSIVE

Specifies that the value of the end column is included in the period. The BUSINESS_TIME period is defined as inclusive-inclusive.

ADD unique-constraint

CONSTRAINT *constraint-name*

Names the primary key or unique key constraint. If a constraint name is not specified, a unique constraint name is generated. If a name is specified, it must be different from the names of any referential, check, primary key, or unique key constraints previously specified on the table. If the table space is implicitly created, the enforcing primary key and unique key indexes are also implicitly created.

PRIMARY KEY(*column-name*,...)

Defines a primary key composed of the identified columns. Each column name must be an unqualified name that identifies a column of the table. The same column must not be identified more than one time. The following types of columns cannot be specified in a PRIMARY KEY clause:

- a LOB column
- a ROWID column
- a distinct type column that is based on a LOB or ROWID data type
- an XML column
- a row change timestamp column

All character and graphic string columns in the key must use the same encoding scheme.

The number of identified columns must not exceed 64. In addition, the sum of the length attributes of the columns must not be greater than $2000 - n - 2m - 3d$, where m is the number of varying-length columns and d is the number of DECFLOAT columns in the key. The table must not have a primary key and the identified columns must be defined as NOT NULL.

The set of columns in the primary key cannot be the same as the set of columns of another unique key.

The table must have a unique index with a unique key that is identical to the primary key. The keys are identical only if they have the same number of columns and the n th column name of one is the same as the n th column name of the other. If the table is in a table space that is implicitly created, and no unique index is defined on the identified columns, Db2 will automatically create a primary index. The privilege set must include the INDEX privilege on the table and the USE privilege on the buffer pool and the storage group. The implicitly created primary key index is owned by the owner of the base table.

The identified columns are defined as the primary key of the table. The description of the index is changed to indicate that it is a primary index. If the table has more than one unique index with a key that is identical to the primary key, the selection of the primary index is arbitrary.

BUSINESS_TIME WITHOUT OVERLAPS

BUSINESS_TIME WITHOUT OVERLAPS can be specified as the last item in the list. If BUSINESS_TIME WITHOUT OVERLAPS is specified, the list must include at least one *column-name* or *key-expression*. When WITHOUT OVERLAPS is specified, the values for the rest of the specified keys are unique with respect to the time for the BUSINESS_TIME period. When BUSINESS_TIME WITHOUT OVERLAPS is specified, the columns of the BUSINESS_TIME period must not be specified as part of the constraint. The specification of BUSINESS_TIME WITHOUT OVERLAPS adds the following to the constraint:

- The end column of the BUSINESS_TIME period in ascending order
- The start column of the BUSINESS_TIME period in ascending order

UNIQUE(*column-name*,...)

Defines a unique key composed of the identified columns with the specified *constraint-name*. If a *constraint-name* is not specified, a name is generated. Each column name must be an unqualified name that identifies a column of the table. The same column must not be identified more than one time. The following types of columns cannot be specified in a UNIQUE clause:

- a LOB column
- a ROWID column
- a distinct type column that is based on a LOB or ROWID data type
- an XML column
- a row change timestamp column

Each identified column must be defined as NOT NULL. The number of identified columns must not exceed 64. In addition, the sum of the length attributes of the columns must not be greater than $2000 - n$ for padded indexes and $2000 - n - 2m - 3d$ for nonpadded indexes, where n is the number of

columns that can contain null values, m is the number of varying-length columns, and d is the number of DECFLOAT columns in the key.

The set of columns in the unique key cannot be the same as the set of columns of the primary key or another unique key. A unique key is a duplicate if it is the same as the primary key or a previously defined unique key. The specification of a duplicate unique key is ignored with a warning.

The table must have a unique index with a key that is identical to the unique key. The keys are identical only if they have the same number of columns and the n th column name of one is the same as the n th column name of the other. If the table is in a table space that is implicitly created, and no unique index is defined on the identified columns, Db2 will automatically create a unique index to enforce the unique key constraint. The privilege set must include the INDEX privilege on the table and the USE privilege on the buffer pool and the storage group. The implicitly created unique key index is owned by the owner of the base table.

The identified columns are defined as a unique key of the table. The description of the index is changed to indicate that it is enforcing a unique key constraint. If the table has more than one unique index with a key that is identical to the unique key, the selection of the enforcing index is arbitrary.

BUSINESS_TIME WITHOUT OVERLAPS

BUSINESS_TIME WITHOUT OVERLAPS can be specified as the last item in the list. If BUSINESS_TIME WITHOUT OVERLAPS is specified, the list must include at least one *column-name* or *key-expression*. When WITHOUT OVERLAPS is specified, the values for the rest of the specified keys are unique with respect to the time for the BUSINESS_TIME period. When BUSINESS_TIME WITHOUT OVERLAPS is specified, the columns of the BUSINESS_TIME period must not be specified as part of the constraint. The specification of BUSINESS_TIME WITHOUT OVERLAPS adds the following to the constraint:

- The end column of the BUSINESS_TIME period in ascending order
- The start column of the BUSINESS_TIME period in ascending order

ADD referential-constraint

CONSTRAINT *constraint-name*

Names the referential constraint. If a constraint name is not specified, a unique constraint name is generated. If a name is specified, it must be different from the names of any referential, check, primary key, or unique key constraints previously specified on the table.

FOREIGN KEY (*column-name,...*) *references-clause*

Specifies a referential constraint with the specified *constraint-name*.

FOREIGN KEY cannot be specified if the table is a history table or an archive table.

Let T1 denote the object table of the ALTER TABLE statement. T1 is the child table for the referential constraint.

The foreign key of the referential constraint is composed of the identified columns and the columns of the BUSINESS_TIME period if the clause PERIOD BUSINESS_TIME is specified. Each *column-name* must be an unqualified name that identifies a column of T1. The same column must not be identified more than one time. If PERIOD BUSINESS_TIME is specified, the columns of the BUSINESS_TIME period must not be specified as part of the constraint. The following types of columns cannot be specified in the FOREIGN KEY clause:

- a LOB column
- a ROWID column
- a DECFLOAT column
- an XML column
- a distinct type column that is based on a LOB, ROWID, or DECFLOAT data type
- a security label column
- a row change timestamp column

The number of identified columns, and the columns of the BUSINESS_TIME period if the clause PERIOD BUSINESS_TIME is specified, must not exceed 64, and the sum of their length attributes must not exceed 255 minus the number of columns that allow null values. The referential constraint is a duplicate if the FOREIGN KEY and the parent table are the same as the FOREIGN KEY and parent table of an existing referential constraint on T1. The specification of a duplicate referential constraint is ignored with a warning. An exception is that a duplicate referential constraint is not allowed if the definition of the constraint includes the PERIOD BUSINESS_TIME clause.

If PERIOD BUSINESS_TIME is specified in the FOREIGN KEY clause, then PERIOD BUSINESS_TIME must also be specified in the REFERENCES clause. If PERIOD BUSINESS_TIME is not specified in the FOREIGN KEY clause, then PERIOD BUSINESS_TIME must also not be specified in the REFERENCES clause.

If PERIOD BUSINESS_TIME is specified in the FOREIGN KEY clause, then the semantic for the BUSINESS_TIME period in both the parent and child tables must be the same.

The foreign key of the referential constraint cannot reference a parent key that contains BUSINESS_TIME WITHOUT OVERLAPS.

REFERENCES *parent-table-name (column-name,...)*

The table name specified after REFERENCES is the parent table for the referential constraint. The *parent-table-name* value must identify a table that exists at the current server. This table is referred to as the parent table in the constraint relationship.

parent-table-name must not identify:

- A catalog table
- A directory table
- A declared global temporary table
- A history table
- An archive table

Let T2 denote the identified parent table and let T1 denote the table that is being changed (T1 and T2 can be the same table).

T2 must have a unique index. The privilege set on T2 must include the ALTER or REFERENCES privilege on the parent table, or the REFERENCES privilege on the columns of the nominated parent key, including the columns of the BUSINESS_TIME period if the PERIOD BUSINESS_TIME clause is specified.

The parent key of the referential constraint is composed of the identified columns, or columns of the BUSINESS_TIME period if PERIOD BUSINESS_TIME is specified. Each *column-name* must be an unqualified name that identifies a column of T2. The same column must not be identified more than one time. If PERIOD BUSINESS_TIME is specified, the columns of the BUSINESS_TIME period must not be specified as part of the constraint. The following types of columns cannot be specified in a REFERENCES clause:

- a LOB column
- a ROWID column
- a DECFLOAT column
- an XML column
- a distinct type column that is based on a LOB, ROWID, or DECFLOAT data type
- a security label column
- a row change timestamp column

The list of column names in the parent key must match the list of column names in a primary key or unique key in the parent table T2. The column names must be specified in the same order as in the primary key or unique key. If PERIOD BUSINESS_TIME was specified for the primary key or unique key of the parent table T2, then PERIOD BUSINESS_TIME must also be specified for the foreign key clause for T1. If any of the referenced columns in T2 has a non-numeric data type, T2 and T1 must use the

same encoding scheme, unless T2 is a Unicode table, and T1 is an EBCDIC table with Unicode key columns. In that case, for each character or graphic string column in T1, the CCSID must be the same as the corresponding column in T2.

If a list of column names is not specified, then T2 must have a primary key. Omission of a list of column names is an implicit specification of the columns of the primary key for T2.

The specified foreign key must have the same number of columns as the parent key of T2 and, except for their names, default values, null attributes and check constraints, the description of the *n*th column of the foreign key must be identical to the description of the *n*th column of the nominated parent key. If the foreign key includes a column defined as a distinct type, the corresponding column of the nominated parent key must be the same distinct type. If a column of the foreign key has a field procedure, the corresponding column of the nominated parent key must have the same field procedure and an identical field description. A *field description* is a description of the encoded value as it is stored in the database for a column that has been defined to have an associated field procedure.

The table space that contains T1 must be available to Db2. If T1 is populated, its table space is placed in a check pending status. A table in a segmented table space is populated if the table is not empty. A table in a table space that is not segmented is considered populated if the table space has ever contained any records.

The referential constraint specified by the FOREIGN KEY clause defines a relationship in which T2 is the parent and T1 is the dependent. A description of the referential constraint is recorded in the catalog.

PERIOD BUSINESS_TIME

Specifies that the BUSINESS_TIME period is considered part of the referential constraint. When PERIOD BUSINESS_TIME is specified, the values for the rest of the specified columns are unique with respect to the specified point of time.

PERIOD BUSINESS_TIME can be specified as the last key expression. If PERIOD BUSINESS_TIME is not the last key expression, an error is returned. If PERIOD BUSINESS_TIME is specified, the columns of the BUSINESS_TIME period must not be specified as part of the constraint.

When PERIOD BUSINESS_TIME is specified, the following columns are implicitly added to the end of the constraint:

- The end column of the BUSINESS_TIME period.
- The start column of the BUSINESS_TIME period.

The PERIOD BUSINESS_TIME clause specifies that there must not be a row in the child table for which the period of time represented by the BUSINESS_TIME period values for that row is not contained in the BUSINESS_TIME period of a corresponding row in the parent table. Furthermore, it is not necessary that there be exactly one corresponding row in the parent table where the BUSINESS_TIME period contains the BUSINESS_TIME period of the child row. As long as the BUSINESS_TIME period of a row in the child table is contained in the union of the BUSINESS_TIME periods of two or more contiguous matching rows in the parent table, the referential constraint is considered satisfied.

When the FOREIGN KEY clause specifies the PERIOD BUSINESS_TIME clause, the following conditions apply:

- The corresponding REFERENCES clause must also specify the PERIOD BUSINESS_TIME clause.
- A unique index with the BUSINESS_TIME WITHOUT OVERLAPS clause must be defined on the table. The table is marked as unavailable until the index is created.
- A unique index must be defined on the parent table with the BUSINESS_TIME WITHOUT OVERLAPS clause.

ON DELETE RESTRICT must be specified when PERIOD BUSINESS_TIME is also specified.

ON DELETE

The delete rule of the relationship is determined by the ON DELETE clause. For more on the concepts used here, see [Referential constraints \(Introduction to Db2 for z/OS\)](#).

If T1 and T2 are the same table, CASCADE or NO ACTION must be specified. SET NULL must not be specified unless some column of the foreign key allows null values. Also, SET NULL must not be specified if any nullable column of the foreign key is a column of the key of a partitioning index. The default value for the rule depends on the value of the CURRENT RULES special register when the ALTER TABLE statement is processed. If the value of the register is 'DB2', the delete rule defaults to RESTRICT; if the value is 'SQL', the delete rule defaults to NO ACTION.

The delete rule applies when a row of T2 is the object of a DELETE or propagated delete operation and that row has dependents in T1. Let p denote such a row of T2.

- If RESTRICT or NO ACTION is specified, an error occurs and no rows are deleted.
- If CASCADE is specified, the delete operation is propagated to the dependents of p in T1.
- If SET NULL is specified, each nullable column of the foreign key of each dependent of p in T1 is set to null.

A cycle involving two or more tables must not cause a table to be delete-connected to itself. Thus, if the relationship would form a cycle:

- The referential constraint cannot be defined if each of the existing relationships that would be part of the cycle have a delete rule of CASCADE.
- CASCADE must not be specified if T2 is delete-connected to T1.

If T1 is delete-connected to T2 through multiple paths, those relationships in which T1 is a dependent and which form all or part of those paths must have the same delete rule and it must not be SET NULL. For example, assume that T1 is a dependent of T3 in a relationship with a delete rule of r and that one of the following is true:

- T2 and T3 are the same table.
- T2 is a descendent of T3 and the deletion of rows from T3 cascades to T2.
- T2 and T3 are both descendents of the same table and the deletion of rows from that table cascades to both T2 and T3.

In this case, the referential constraint cannot be defined when r is SET NULL. When r is other than SET NULL, the referential constraint can be defined, but the delete rule that is implicitly or explicitly specified in the FOREIGN KEY clause must be the same as r .

ENFORCED or NOT ENFORCED

Indicates whether or not the referential constraint is enforced by Db2 during normal operations, such as insert, update, or delete.

ENFORCED

Specifies that the referential constraint is enforced by Db2 during normal operations (such as data change operations) and that it is guaranteed to be correct. ENFORCED is the default.

NOT ENFORCED

Specifies that the referential constraint is not enforced by Db2 during normal operations (such as data change operations). NOT ENFORCED should only be used when the data that is stored in the table is verified to conform to the constraint by some other method than relying on Db2.

ENABLE QUERY OPTIMIZATION

Specifies that the constraint can be used for query optimization. Db2 uses the information in query optimization using materialized query tables with the assumption that the constraint is correct. This is the default.

ADD check-constraint

CONSTRAINT *constraint-name*

Names the check constraint. If *constraint-name* is not specified, a unique constraint name is derived from the name of the first column in the *check-condition* specified in the definition of the check constraint. If a name is specified, it must be different from the names of any referential, check, primary key, or unique key constraints previously specified on the table.

CHECK (*check-condition*)

Defines a check constraint. At any time, *check-condition* must be true or unknown for every row of the table. A *check-condition* can evaluate to unknown if a column that is an operand of the predicate is null. A *check-condition* that evaluates to unknown does not violate the check constraint. A *check-condition* is a search condition, with the following restrictions:

- It can refer only to the columns of table *table-name*.
- The columns cannot be any of the following types of columns:
 - LOB columns
 - ROWID columns
 - DECFLOAT columns
 - XML columns
 - distinct type columns that are based on LOB, ROWID, and DECFLOAT data types
 - security label columns
- It must not result in CCSID conversion.
- It can be up to 7400 bytes long, not including redundant blanks.
- It must not contain any of the following:
 - Subselects
 - Built-in or user-defined functions
 - CAST specifications
 - Cast functions other than those created when the distinct type was created
 - Host variables
 - Global variables
 - Parameter markers
 - Special registers
 - Columns that include a field procedure
 - CASE expressions
 - ROW CHANGE expressions
 - Row-value expressions
 - DISTINCT predicates
 - GX constants (hexadecimal graphic string constants)
 - Sequence references
 - OLAP specifications
- If a *check-condition* refers to a LOB column (including a distinct type that is based on a LOB), the reference must occur within a LIKE predicate.
- The AND and OR logical operators can be used between predicates. The NOT logical operator cannot be used.
- The first operand of every predicate must be the column name of a column in the table.
- The second operand in the *check-condition* must be either a constant or a column name of a column in the table.
 - If the second operand of a predicate is a constant, and if the constant is:
 - A floating-point number, then the column data type must be floating point.
 - A decimal number, then the column data type must be either floating point or decimal.
 - A big integer number, then the column data type must not be an integer or a small integer
 - An integer number, then the column data type must not be a small integer.

- A small integer number, then the column data type must be small integer.
- A decimal constant, then its precision must not be larger than the precision of the column.
- If the second operand of a predicate is a column, then both columns of the predicate must have:
 - The same data type
 - Identical descriptions with the exception that the specification of the NOT NULL and DEFAULT clauses for the columns can be different, and that string columns with the same data type can have different length attributes

Effects of defining a check constraint on a populated table: When a check constraint is defined on a populated table and the value of the special register CURRENT RULES is 'DB2', the check constraint is not immediately enforced on the table. The check constraint is added to the description of the table, and the table space that contains the table is placed in a check pending status. For a description of the check pending status and the implications for utility operations, see [CHECK-pending status \(Db2 Utilities\)](#).

When a check constraint is defined on a populated table and the value of the special register CURRENT RULES is 'STD', the check constraint is checked against all rows of the table. If no violations occur, the check constraint is added to the table. If any rows violate the new check constraint, an error occurs and the description of the table is unchanged.

DROP constraint

DROP PRIMARY KEY

Drops the definition of the primary key and all referential constraints in which the primary key is a parent key. The table must have a primary key and the privilege set must include the ALTER or REFERENCES privilege on every dependent table of the table.

The description of the primary index is changed to indicate that it is not a primary index. If the table space was implicitly created, the corresponding enforcing index is dropped if the primary key is dropped.

DROP UNIQUE *constraint-name*

Drops the definition of the unique key constraint and all referential constraints in which the unique key is a parent key. The table must have a unique key. The privilege set must include the ALTER or REFERENCES privilege on every dependent table of the table. The description of the enforcing index is changed to indicate that it is not enforcing a unique key constraint. If the table space is implicitly created, the corresponding enforcing index is dropped if the unique key is dropped.

DROP FOREIGN KEY *constraint-name*

Drops the referential constraint *constraint-name*. The *constraint-name* must identify a referential constraint in which the table is the dependent table, and the privilege set must include the ALTER or REFERENCES privilege on the parent table of that relationship, or the REFERENCES privilege on the columns of the parent table of that relationship.

DROP CHECK *constraint-name*

Drops the check constraint *constraint-name*. The *constraint-name* must identify an existing check constraint defined on the table.

DROP CONSTRAINT *constraint-name*

Drops the constraint *constraint-name*. The *constraint-name* must identify an existing primary key, unique key, check, or referential constraint defined on the table.

DROP CONSTRAINT must not be used on the same ALTER TABLE statement as DROP PRIMARY KEY, DROP UNIQUE KEY, DROP FOREIGN KEY or DROP CHECK.

ADD PARTITION BY RANGE *partitioning-clause*

Specifies the range partitioning scheme for the table (the columns used to partition the data). The RANGE keyword is optional.

When this clause is specified, the table uses table-controlled partitioning. The number of partitions specified in the ADD PARTITION BY RANGE clause has to be the same as the number of partitions defined in the table space.

This clause applies only to tables in a partitioned table space. If the table is already complete by having established either table-controlled partitioning or index-controlled partitioning, the ADD PARTITION BY RANGE clause is not allowed. If this clause is used, then the ENDING AT clause cannot be used on a subsequent CREATE INDEX statement for this table.

partitioning-clause

partition-expression

Specifies the key data over which the range is defined to determine the target data partition of the data.

column-name

Specifies the columns of the key. Each *column-name* must identify a column of the table. Do not specify more than 64 columns, the same column more than one time, a qualified column name, or any of the following types of columns:

- a BINARY or VARBINARY column
- a LOB column
- a DECFLOAT column
- an XML column
- a column with a distinct type that is based on any of the preceding data types

All character and graphic string columns in the key must use the same encoding scheme.

The sum of length attributes of the columns must not be greater than $255 - n$, where n is the number of columns that can contain null values.

A timestamp with time zone column (or a column with a distinct type that is based on the timestamp with time zone data type) can only be specified as the last column in a partitioning key.

NULLS LAST

Specifies that null values are treated as positive infinity for purposes of comparison.

ASC

Puts the entries in ascending order by the column. ASC is the default.

DESC

Puts the entries in descending order by the column.

partition-element

Specifies ranges for a data partitioning key and the table space where rows of the table in the range will be stored.

PARTITION integer

Specifies a number of a physical partition in the table space. A PARTITION clause must be specified for every partition of the table space. In the context, highest means highest in the sorting sequence of the columns. In a column that is defined as ascending (ASC), highest and lowest have the usual meanings. In a column that is defined as descending (DESC), the lowest actual value is the highest in the sorting sequence.

ENDING AT (constant, MAXVALUE, or MINVALUE...)

Specifies the limit key for a partition boundary. Specify at least one value (constant, MAXVALUE, or MINVALUE) after ENDING AT in each PARTITION clause. You can use as many values as there are columns in the key. The concatenation of all the values is the highest value of the key for ascending and the lowest for descending.

constant

Specifies a constant value with a data type that must conform to the rules for assigning that value to the column. If a string constant is longer or shorter than required by the length attribute of its column, the constant is either truncated or padded on the right to the required

length. If the column is ascending, the padding character is X'FF'. If the column is descending, the padding character is X'00'. The precision and scale of a decimal constant must not be greater than the precision and scale of its corresponding column. A hexadecimal string constant (GX) cannot be specified.

MAXVALUE

Specifies a value greater than the maximum value for the limit key of a partition boundary (that is, all X'FF' regardless of whether the column is ascending or descending). If all of the columns in the partitioning key are ascending, a constant or the MINVALUE clause cannot be specified following MAXVALUE. After MAXVALUE is specified, all subsequent columns must specify MAXVALUE.

MINVALUE

Specifies a value that is smaller than the minimum value for the limit key of a partition boundary (that is, all X'00' regardless of whether the column is ascending or descending). If all of the columns in the partitioning key are descending, a constant or the MAXVALUE clause cannot be specified following MINVALUE. After MINVALUE is specified, all subsequent columns must be MINVALUE.

The key values are subject to the following rules:

- The first value corresponds to the first column of the key, the second value to the second column, and so on. Using fewer values than there are columns in the key has the same effect as using the highest or lowest values for the omitted columns, depending on whether they are ascending or descending.
- The highest value of the key in any partition must be lower than the highest value of the key in the next partition.
- The values specified for the last partition are enforced. The value specified for the last partition is the highest value of the key that can be placed in the table. If the limit was not previously enforced, any existing key values that are greater than the value that is specified for the added partition are placed into the discard data set when REORG is run.
- If a key includes a ROWID column or a column with a distinct type that is based on a ROWID data type, 17 bytes of the constant that is specified for the corresponding ROWID column are considered.
- The combination of the number of table space partitions and the corresponding limit key size cannot exceed the number of partitions * (106 + limit key size in bytes) < 65394
- If the concatenation of all the values exceeds 255 bytes, only the first 255 bytes are considered.

INCLUSIVE

Specifies that the specified range values are included in the data partition.

ADD PARTITION

ADD PARTITION

Specifies that a partition is added to the table and each partitioned index on the table. A partition can be added as the last logical partition of any partitioned table space. Partitions can also be added between existing logical partitions in partition-by-range table spaces. The new partition is the next physical partition not being used until the maximum for the table space has been reached. ADD PARTITION must not be specified for nonpartitioned tables. Adding a partition is not allowed if the table is a materialized query table, or if a materialized query table is defined on the table. However, adding a partition is allowed if an accelerated query table is defined on the table.

Depending on the situation when this clause is specified, Db2 might process the ALTER statement as a *pending data definition change*, which means the current object definition and data do not reflect the alteration at the time that the statement is issued. Instead, the affected partitions placed in an advisory REORG-pending (AREOR) state, and a subsequent reorganization of the affected partitions with an appropriate utility materializes the changes to the catalog and data. For more information, see [Pending data definition changes \(Db2 Administration Guide\)](#).

Adding a partition as the last logical partition of a table specifies that a partition is added to the table and each partitioned index on the table. A partition added as the last logical partition is always an immediate definition change. A partition cannot be added if the table space definition is incomplete because a partitioning key or partitioning index is missing. If the table uses index-controlled partitioning, it is converted to use table-controlled partitioning. In addition, adding a partition to the end of the table is not allowed if there are any outstanding pending definition changes on the partitions.

Adding a partition between existing logical partitions is supported only for partition-by-range table spaces. When inserting a new partition between existing partitions, the following rules apply:

- If ADD PARTITION ENDING with the optional ALTER PARTITION clause is used to add a new partition between existing partitions, the ALTER PARTITION clause must specify the very next logical partition to the partition being added. The high limit key value specified in the ALTER PARTITION clause must be the existing high limit key value for the very next logical partition. The high limit key value cannot be altered in the same statement when inserting a new partition.
- Any pending definition changes for the high limit key of the last logical partition must be materialized before a partition can be added between existing partitions in the same table.
- After a new partition is added between existing partitions of a table, altering the limit key is not allowed for any partition in the same table until the newly inserted partition is materialized by a REORG execution.
- A partition cannot be inserted on any table that contains a LOB column, or a distinct type column that is based on a LOB data type.
- A partition cannot be inserted on any table that contains an XML column.

If the table is in a partition-by-growth table space, a new partition can be added until the number of partitions reaches the MAXPARTITIONS limit. The total number of table space partitions cannot exceed the value that is specified for MAXPARTITIONS for the table space.

The default DSSIZE is determined by the value in SYSIBM.SYSTABLESPACE catalog table. The maximum number of partitions allowed is shown in the following table.

Table 181. Maximum number of partitions allowed

DSSIZE	Page size 4 KB	Page size 8 KB	Page size 16 KB	Page size 32 KB
1GB-4GB	4096	4096	4096	4096
8GB	2048	4096	4096	4096
16GB	1024	2048	4096	4096
32GB	512	1024	2048	4096
64GB	256	512	1024	2048
128GB	128	256	512	1024
256GB	64	128	256	512

If LARGE was specified when the table space was created, the maximum number of partitions is shown in the fourth row of [Table 182 on page 1277](#). For more than 254 partitions when LARGE or DSSIZE is not specified, the maximum number of partitions is determined by the page size of the table space.

Table 182. Maximum number of partitions when DSSIZE = 0

Type of table space	Number of existing partitions	Maximum partitions
non-large	1 to 16	16

Table 182. Maximum number of partitions when DSSIZE = 0 (continued)

Type of table space	Number of existing partitions	Maximum partitions
non-large	17 to 32	32
non-large	33 to 64	64
large	N/A	4096

The new partition inherits most attributes from the table space or the previous last logical partition, depending on the position of the new partition and other factors. For details see [How Db2 determines attributes for added partitions \(Db2 Administration Guide\)](#).

To change specific attributes of the added partition, you can issue separate ALTER TABLESPACE and ALTER INDEX statements after you add the partition.

If the table uses index-controlled partitioning, it is converted to use table-controlled partitioning. Db2 enforces the high limit key for table-controlled partitioning, so any existing key values that are greater than the high limit key are placed into the discard data set when REORG is run.

HASH SPACE cannot be specified with ADD PARTITION. For partition-by-growth table spaces, the hash space value is not applicable at the partition level.

ENDING AT (constant, MAXVALUE, or MINVALUE, ...)

Specifies the high key limit for the new partition.

Specify at least one value after ENDING AT in the PARTITION clause. You can specify as many values as there are columns in the key. The concatenation of all the values is the highest value of the key in the corresponding partition of the index. ENDING AT cannot be specified for a table in a partition-by-growth table space, but must be specified if the table is in a partition-by-range table space.

constant

Specifies a constant value with a data type that must conform to the rules for assigning that value to the column. If a string constant is longer or shorter than required by the length attribute of its column, the constant is either truncated or padded on the right to the required length. If the column is ascending, the padding character is X'FF'. If the column is descending, the padding character is X'00'. The precision and scale of a decimal constant must not be greater than the precision and scale of its corresponding column. A hexadecimal string constant (GX) cannot be specified.

MAXVALUE

Specifies a value greater than the maximum value for the limit key of a partition boundary (that is, all X'FF' regardless of whether the column is ascending or descending). If all of the columns in the partitioning key are ascending, a constant or the MINVALUE clause cannot be specified following MAXVALUE. After MAXVALUE is specified, all subsequent columns must specify MAXVALUE.

MINVALUE

Specifies a value that is smaller than the minimum value for the limit key of a partition boundary (that is, all X'00' regardless of whether the column is ascending or descending). If all of the columns in the partitioning key are descending, a constant or the MAXVALUE clause cannot be specified following MINVALUE. After MINVALUE is specified, all subsequent columns must be MINVALUE.

The key values are subject to the following rules:

- The first value corresponds to the first column of the key, the second value to the second column, and so on. Using fewer values than there are columns in the key has the same effect as using the highest or lowest values for the omitted columns, depending on whether they are ascending or descending.
- The highest value of the key in any partition must be lower than the highest value of the key in the next partition.

- The values specified for the last partition are enforced. The value specified for the last partition is the highest value of the key that can be placed in the table. If the limit was not previously enforced, any existing key values that are greater than the value that is specified for the added partition are placed into the discard data set when REORG is run.
- If a key includes a ROWID column or a column with a distinct type that is based on a ROWID data type, 17 bytes of the constant that is specified for the corresponding ROWID column are considered.
- The combination of the number of table space partitions and the corresponding limit key size cannot exceed the number of partitions * (106 + limit key size in bytes) < 65394
- If the concatenation of all the values exceeds 255 bytes, only the first 255 bytes are considered.

INCLUSIVE

Specifies that the specified range values are included in the data partition.

partition-hash-space

See [partition-hash-space](#).

Be aware that specifying the ADD PARTITION clause might affect subsequent requests to recover to a point in time. See [Point-in-time recovery \(Db2 Utilities\)](#) for information about possible restrictions, effects on recovery status, and other considerations.

ALTER PARTITION

ALTER PARTITION

Specifies that the partitioning limit key for the identified partition is to be changed.

This clause applies only to tables in a partitioned table space. ALTER PARTITION must not be specified for a table in a partition-by-growth table space or for tables that have XML columns. If there are any pending definition changes to insert a new partition in the middle of the table for a partition-by-range table space, altering the limit key is not allowed for any partition in the same table until the newly inserted partition is materialized by a REORG execution.

If the table uses index-controlled partitioning, it is converted to use table-controlled partitioning. The high limit key for the last partition is set to the highest possible value for ascending key columns or the lowest possible value for descending key columns. The alteration is immediate and the altered partition is placed in REORG-pending (REORP) status. If the altered partition is not the last logical partition, the next logical partition is also placed in REORG-pending (REORP) status.

integer

Identifies the physical partition number in the range 1–*n*, where *n* is the number of partitions in the table. *integer* is the physical partition number.

Depending on the situation when this clause is specified, Db2 might process the ALTER statement as a *pending data definition change*, which means the current object definition and data do not reflect the alteration at the time that the statement is issued. Instead, the affected partitions placed in an advisory REORG-pending (AREOR) state, and a subsequent reorganization of the affected partitions with an appropriate utility materializes the changes to the catalog and data. For more information, see [Pending data definition changes \(Db2 Administration Guide\)](#).

If an immediate change is used, it places the affected partitions in REORG-pending (REORP) status if *integer* identifies the last logical partition, the partition data set ever contained any data, and the limit key is altered to a different value from MAXVALUE (for ascending) or from MINVALUE (for descending).

ENDING AT (*constant*, MAXVALUE, or MINVALUE...)

Specifies the highest value of the partitioning key for the identified partition.

In this context, highest means highest in the sorting sequences of the columns. In a column defined as ascending (ASC), highest and lowest have their usual meanings. In a column defined as descending (DESC) the lowest actual value is highest in the sorting sequence.

Specify at least one value after ENDING AT in each ALTER PARTITION clause. You can use as many values as there are columns in the key. The concatenation of all the values is the highest

value of the key in the corresponding partition. The length of each highest key value (the limit key) is the same as the length of the partitioning key.

constant

Specifies a constant value with a data type that must conform to the rules for assigning that value to the column. If a string constant is longer or shorter than required by the length attribute of its column, the constant is either truncated or padded on the right to the required length. If the column is ascending, the padding character is X'FF'. If the column is descending, the padding character is X'00'. The precision and scale of a decimal constant must not be greater than the precision and scale of its corresponding column. A hexadecimal string constant (GX) cannot be specified.

MAXVALUE

Specifies a value greater than the maximum value for the limit key of a partition boundary (that is, all X'FF' regardless of whether the column is ascending or descending). If all of the columns in the partitioning key are ascending, a constant or the MINVALUE clause cannot be specified following MAXVALUE. After MAXVALUE is specified, all subsequent columns must specify MAXVALUE.

MINVALUE

Specifies a value that is smaller than the minimum value for the limit key of a partition boundary (that is, all X'00' regardless of whether the column is ascending or descending). If all of the columns in the partitioning key are descending, a constant or the MAXVALUE clause cannot be specified following MINVALUE. After MINVALUE is specified, all subsequent columns must be MINVALUE.

The key values are subject to the following rules:

- The first value corresponds to the first column of the key, the second value to the second column, and so on. Using fewer values than there are columns in the key has the same effect as using the highest or lowest values for the omitted columns, depending on whether they are ascending or descending.
- The highest value of the key in any partition must be lower than the highest value of the key in the next partition.
- The values specified for the last partition are enforced. The value specified for the last partition is the highest value of the key that can be placed in the table. If the limit was not previously enforced, any existing key values that are greater than the value that is specified for the added partition are placed into the discard data set when REORG is run.
- If a key includes a ROWID column or a column with a distinct type that is based on a ROWID data type, 17 bytes of the constant that is specified for the corresponding ROWID column are considered.
- The combination of the number of table space partitions and the corresponding limit key size cannot exceed the number of partitions * (106 + limit key size in bytes) < 65394
- If the concatenation of all the values exceeds 255 bytes, only the first 255 bytes are considered.

The value that is specified must not be equal to or beyond the range of the partition boundaries of the adjacent partitions.

INCLUSIVE

Specifies that the specified range values are included in the data partition.

partition-hash-space

See [partition-hash-space](#).

Be aware that specifying the ALTER PARTITION clause might affect subsequent requests to recover to a point in time. See [Point-in-time recovery \(Db2 Utilities\)](#) for information about possible restrictions, effects on recovery status, and other considerations.

ROTATE PARTITION

ROTATE PARTITION FIRST or *integer* TO LAST

Specifies that the first logical partition or the physical partition that corresponds to *integer* is to be rotated to become the last partition. Processing resets the specified partition to empty, and the limit key that is associated with the partition is set to the constant that is specified with the boundary specification clause. For ascending limit keys, the new limit key must be higher than the limit key for the preexisting last logical partition prior to this statement being processed. For descending limit keys, the new limit must be lower than the limit for the preexisting last logical partition prior to this statement being processed.

The table definition must be complete and must contain more than one partition. This clause must be followed by the ENDING AT clause, which specifies the new high key limit for this partition, which is now logically last.

Rotating a partition occurs immediately. If there is a referential constraint with DELETE RESTRICT on the table, the ROTATE might fail. If the table uses index-controlled partitioning, it is converted to use table-controlled partitioning.

After an ALTER TABLE statement with the ROTATE PARTITION clause is run, the RUNSTATS utility or the REORG utility with the STATISTICS option should be run on the table space to ensure effective access paths are available for selection.

If the table has a security label column, the user must have a valid security label to rotate partitions. In addition, if write-down is in effect, the user must have the write-down privilege.

ROTATE PARTITION must not be specified in the following situations:

- The table is in a partition-by-growth table space.
- The table has XML columns.
- The table is a system-period temporal table or a history table.
- The table is an archive-enabled table or an archive table.

Adding a partition is allowed if an accelerated query table is defined on the table.

If the table uses index-controlled partitioning, it is converted to use table-controlled partitioning. Db2 enforces the high limit key for table-controlled partitioning, so any existing key values that are greater than the high limit key are placed into the discard data set when REORG is run.

integer

Specifies a positive integer that represents a physical partition number as identified by the PARTITION column of the SYSIBM.SYSTABLEPART catalog table. The partition must be a data partition that exists in the table. The partition cannot be the last partition of the table.

ENDING AT (*constant*, MAXVALUE, or MINVALUE...)

The ENDING AT clause specifies the new high key limit for the existing partition holding the oldest data.

In this context, highest means highest in the sorting sequences of the columns. In a column defined as ascending (ASC), highest and lowest have their usual meanings. In a column defined as descending (DESC) the lowest actual value is highest in the sorting sequence.

Specify at least one value after ENDING AT. You can use as many values as there are columns in the key. The concatenation of all the values is the highest value of the key in the corresponding partition. The length of each highest key value (the limit key) is the same as the length of the partitioning key.

constant

Specifies a constant value with a data type that must conform to the rules for assigning that value to the column. If a string constant is longer or shorter than required by the length attribute of its column, the constant is either truncated or padded on the right to the required length. If the column is ascending, the padding character is X'FF'. If the column is descending, the padding character is X'00'. The precision and scale of a decimal constant must not be greater than the precision and scale of its corresponding column. A hexadecimal string constant (GX) cannot be specified.

MAXVALUE

Specifies a value greater than the maximum value for the limit key of a partition boundary (that is, all X'FF' regardless of whether the column is ascending or descending). If all of the columns in the partitioning key are ascending, a constant or the MINVALUE clause cannot be specified following MAXVALUE. After MAXVALUE is specified, all subsequent columns must specify MAXVALUE.

MINVALUE

Specifies a value that is smaller than the minimum value for the limit key of a partition boundary (that is, all X'00' regardless of whether the column is ascending or descending). If all of the columns in the partitioning key are descending, a constant or the MAXVALUE clause cannot be specified following MINVALUE. After MINVALUE is specified, all subsequent columns must be MINVALUE.

The key values are subject to the following rules:

- The first value corresponds to the first column of the key, the second value to the second column, and so on. Using fewer values than there are columns in the key has the same effect as using the highest or lowest values for the omitted columns, depending on whether they are ascending or descending.
- The highest value of the key in any partition must be lower than the highest value of the key in the next partition.
- The values specified for the last partition are enforced. The value specified for the last partition is the highest value of the key that can be placed in the table. If the limit was not previously enforced, any existing key values that are greater than the value that is specified for the added partition are placed into the discard data set when REORG is run.
- If a key includes a ROWID column or a column with a distinct type that is based on a ROWID data type, 17 bytes of the constant that is specified for the corresponding ROWID column are considered.
- The combination of the number of table space partitions and the corresponding limit key size cannot exceed the number of partitions * (106 + limit key size in bytes) < 65394
- If the concatenation of all the values exceeds 255 bytes, only the first 255 bytes are considered.

INCLUSIVE

Specifies that the specified range values are included in the data partition.

RESET

Specifies that the existing data in the first logical partition is deleted. Also, the key entries from the associated physical and logical index partitions are deleted.

In a partitioned table with limit values that are in ascending sequence, ALTER TABLE ROTATE PARTITION FIRST TO LAST logically operates as if the partition with the lowest high key limit were dropped and then a new partition was added with the specified high key limit. The new key limit for the partition must be higher than any other partition in the table. For descending limit keys, the rotation operates as the partition with the highest limit values becomes the partition with the lowest limit values.

If the partition contains any of the following attributes, Db2 deletes each data row in the partition individually:

- Referential integrity parent relationships
- DATA CAPTURE logging enabled
- Delete row triggers
- Validation procedures

If the table resides in a partition-by-range table space and does not have any of the previous attributes, Db2 uses mass delete processing, and individual data rows are not touched or logged.

Be aware that specifying the ROTATE PARTITION clause might affect subsequent requests to recover to a point in time. See [Point-in-time recovery \(Db2 Utilities\)](#) for information about possible restrictions, effects on recovery status, and other considerations.

DROP ORGANIZATION

DROP ORGANIZATION

Specifies that the data organization definition for the table is dropped. The entire table becomes inaccessible and is placed in REORG-pending status. REORG must be run to make the table accessible. If the table is in a partition by range universal table space, the entire table space must be reorganized at one time.

If any type of clustering is required, you must create the clustering index or add the MEMBER CLUSTER clause to the table.

After the next time the REORG utility is run, the hash space value will be cleared and the implicitly created hash overflow index will be dropped.

DROP ORGANIZATION must only be specified for has-organized tables.

Use of this clause or keyword might invalidate packages that depend on the target object, or packages that depend on related objects through cascading effects. See [Changes that invalidate packages \(Db2 Application programming and SQL\)](#).

ADD ORGANIZE BY HASH or ALTER ORGANIZATION

Deprecated function: FL 504 Hash-organized tables are deprecated. Beginning in Db2 12, packages bound with APPLCOMPAT(V12R1M504) or higher cannot create hash-organized tables or alter existing tables to use hash-organization. Existing hash organized tables remain supported, but they are likely to be unsupported in the future.

For information, see [hash-organization](#).

ADD VERSIONING

ADD VERSIONING

Specifies that the table is a system-period temporal table.

The table must not already be defined as a system-period temporal table, a history table, an archive-enabled table, or an archive table.

A SYSTEM_TIME period and a *transaction-start-ID* column must be defined for the table. The data type, length, precision, and scale for a *transaction-start-ID* column must be defined the same as the *row-begin* column and *row-end* column of the SYSTEM_TIME period in the table. The table must be the only table in the table space. The table must not be a materialized query table, an incomplete table, an auxiliary table, a table that is involved in a clone relationship, a table that was implicitly created for an XML column, or a table that contains a security label column. ADD VERSIONING must not be specified with other clauses on the ALTER TABLE statement.

The privilege set must include the privileges to issue an ALTER TABLE statement for the associated history table.

Historical versions of the rows in the table are retained by Db2. A system-period temporal table contains extra information that indicates when a row is inserted into the table, and when it is updated or deleted. An associated history table is used to store the historical rows of the table. When data in the system-period temporal table is updated, the previous version of the row is kept in the associated history table. When data in a system-period temporal table is deleted, the last version of the row is inserted into the history table.

References to the table can include a period clause to indicate which versions of the data are returned.

Use of this clause or keyword might invalidate packages that depend on the target object, or packages that depend on related objects through cascading effects. See [Changes that invalidate packages \(Db2 Application programming and SQL\)](#).

USE HISTORY TABLE *history-table-name*

Specifies a history table in which to keep the historical rows of the system-period temporal table.

If the history table contains data, ensure that the data accurately represents historical rows. If the data does not accurately represent historical rows, the results of temporal queries might be unexpected.

history-table-name must identify a table that exists at the current server and must not identify one of the following tables:

- A system-period temporal table. The table was defined as a system-period temporal table by a previous statement, or the current statement defines the table as a system-period temporal table.
- An existing history table.
- An archive-enabled table.
- An archive table.
- A declared global temporary table.
- A created global temporary table.
- A materialized query table.
- A view.
- An auxiliary table.
- A table that was implicitly created for an XML column.
- A table that is involved in a clone relationship.

The history table must be the only table in the table space.

Restrictions:

- The history table must not contain any of the following columns:
 - Identity column
 - Row change timestamp column
 - Row-begin column
 - Row-end column
 - Transaction-start-ID column
 - Generated expression column
 - Column mask
 - Security label column.
- The history table must not include a period.
- The history table must not have an incomplete table definition.
- A row permission must not be defined for the history table.

The encoding scheme and CCSID for the system-period temporal table and identified history table must be the same.

The system-period temporal table and the identified history table must have the same number and order of columns. The following attributes of the corresponding columns of the two tables must be the same:

- name
- data type
- length (excluding inline LOB length), precision, and scale
- subtype and CCSID
- null attribute
- hidden attribute
- field procedure

If a column of the system-period temporal table is defined as ROWID GENERATED ALWAYS, the corresponding history column should be defined as ROWID GENERATED ALWAYS.

If a column of the system-period temporal table is defined as GENERATED ALWAYS FOR EACH ROW ON UPDATE OF ROW CHANGE TIMESTAMP or GENERATED AS IDENTITY, the corresponding column in the history table cannot be defined with a GENERATED attribute.

ON DELETE ADD EXTRA ROW

Specifies that an additional row is inserted into the associated history table when a row is deleted from a system-period temporal table. These additional history rows are not returned for a query with a period specification for a system-period temporal table. The content of the columns of the additional row in the history table are determined as follows:

- New values are generated for each column that corresponds to a non-deterministic generated expression column.
- The column that corresponds to the row-begin column is set to the same value as the column that corresponds to the row-end column.
- The other columns are set to the same value as in the row inserted into the history table for the delete.

The ON DELETE ADD EXTRA ROW clause is intended to be used when the system-period temporal table contains a non-deterministic generated expression column. The generated expression columns in an extra row contain information about the delete operation that resulted in that extra row in the history table.

For more information, see [Temporal tables and data versioning \(Db2 Administration Guide\)](#).

DROP VERSIONING

DROP VERSIONING

Specifies that the table is no longer a system-period temporal table. *table-name* must identify a system-period temporal table. Historical data will no longer be recorded and maintained for the table. The definition of the columns and data of the table *table-name* are not changed, but the table is no longer treated as a system-period temporal table. The SYSTEM_TIME period is retained. The relationship between the system-period temporal table and history table is removed. The history table is not dropped, only the relationship between the two tables is removed. Subsequent queries that reference the table must not specify a SYSTEM_TIME period specification for the table.

Use of this clause or keyword might invalidate packages that depend on the target object, or packages that depend on related objects through cascading effects. See [Changes that invalidate packages \(Db2 Application programming and SQL\)](#).

Versioning cannot be dropped if there are any views, materialized query table definitions, or SQL table functions that depend on the SYSTEM_TIME period.

DROP VERSIONING must not be specified with any other clauses on the ALTER TABLE statement.

The privilege set must include the privileges to issue an ALTER TABLE statement for the associated history table.

ADD MATERIALIZED QUERY

ADD MATERIALIZED QUERY *materialized-query-definition*

Changes a base table to a materialized query table. Supplies a definition for a regular table to make it a materialized query table. The table specified by *table-name* and the result columns of the fullselect must not have the following characteristics:

- Be already defined as a materialized query table
- Have any primary keys, unique constraints (unique indexes), referential constraints (foreign keys), check constraints, or triggers defined
- Be referenced in the definition of another materialized query table

- Be directly or indirectly referenced in the *fullselect*
- Be in an incomplete state
- Be a system-period temporal table or a history table
- Be a base table that has been activated for the row access controls or column access controls
- Be a base table for which a row permission or a column mask has been defined
- Be an archive-enabled table or an archive table

If *table-name* does not meet these criteria, an error occurs.

The fullselect must not contain a period specification.

The object that is specified in the FROM clause of the fullselect cannot be a view with columns of length 0.

fullselect

Defines the query on which the table is based. The columns of the existing table must meet the following characteristics:

- Have the same number of columns
- Have exactly the same column definitions
- Have the same column names in the same ordinal positions

The *fullselect* must not directly or indirectly reference a base table that has been activated for the row access controls or column access controls or reference a base table for which a row permission or a column mask has been defined.

The *fullselect* cannot contain a reference to a created global temporary table, a declared global temporary table, an accelerator-only table, a directory table, or another materialized query table.

The outermost SELECT clause of *fullselect* must not result in a column that is an array.

The outermost SELECT list of the fullselect can include result columns that are defined as EBCDIC columns and result columns that are defined as Unicode columns. In this case, the materialized query table is an EBCDIC table with one or more Unicode columns.

If fullselect is specified, the owner of the table being altered must have the SELECT privilege on the tables or views referenced in the fullselect. Having SELECT privilege means that the owner has at least one of the following authorizations:

- Ownership of the tables or views referenced in the fullselect
- The SELECT privilege on the tables and views referenced in the fullselect
- SYSADM authority
- DBADM authority for the database in which the table of the fullselect reside

Additional privileges might be necessary for accessing other objects that are referenced in the fullselect.

If the owner of the table does not have the SELECT privilege, the following authorization IDs must have SYSADM authority or DBADM authority for the database in which the tables of the fullselect reside:

- For embedded statements, the authorization ID of the owner of the plan or package
- For dynamically prepared statements, the SQL authorization ID of the process

For details about specifying *fullselect* for a materialized query table, see the definition of *fullselect* in the [“CREATE TABLE statement”](#) on page 1650 statement.

Use of this clause or keyword might invalidate packages that depend on the target object, or packages that depend on related objects through cascading effects. See [Changes that invalidate packages \(Db2 Application programming and SQL\)](#).

refreshable-table-options

Specifies the materialized query table options for altering a regular table to a materialized query table. The ORDER BY clause is allowed, but it is used only by REFRESH. The ORDER BY clause can improve the locality of reference of data in the materialized query table.

DATA INITIALLY DEFERRED

Specifies that the data in the table is not validated as part of the ALTER TABLE statement. A REFRESH TABLE statement can be used to make sure the data in the materialized query table is the same as the result of the query in which the table is based.

REFRESH DEFERRED

Specifies that the data in the table can be refreshed at any time using the REFRESH TABLE statement. The data in the table only reflects the result of the query as a snapshot at the time when the REFRESH TABLE statement is processed or as updated by the user for a user-maintained materialized query table.

MAINTAINED BY SYSTEM or MAINTAINED BY USER

Specifies how the data in the materialized query table is maintained.

MAINTAINED BY SYSTEM

Specifies that the data in the materialized query table *table-name* is to be maintained by the system. Only the REFRESH TABLE statement is allowed on the table.

MAINTAINED BY USER

Specifies that the data in materialized query table *table-name* is to be maintained by the user, who can use LOAD utility or SQL data change statements and REFRESH TABLE statements on the table.

ENABLE QUERY OPTIMIZATION or DISABLE QUERY OPTIMIZATION

Specifies whether this materialized query table can be used for optimization.

ENABLE QUERY OPTIMIZATION

Specifies that the materialized query table can be used for query optimization. If the fullselect specified does not satisfy the restrictions for query optimization, an error occurs. For detailed rules to satisfy query optimization, see *materialized-query-definition* in the “CREATE TABLE statement” on page 1650 statement.

DISABLE QUERY OPTIMIZATION

Specifies that the materialized query table cannot be used for query optimization. The table can still be queried directly.

ALTER MATERIALIZED QUERY

ALTER MATERIALIZED QUERY *materialized-query-table-alteration*

Changes attributes of a materialized query table. The *table-name* must identify a materialized query table.

SET *refreshable-table-alteration*

Changes how the table is maintained or whether the table can be used in query optimization.

MAINTAINED BY SYSTEM

Specifies that the data in a materialized query table *table-name* is to be maintained by the system.

MAINTAINED BY USER

Specifies that the data in the materialized query table *table-name* is to be maintained by the user.

ENABLE QUERY OPTIMIZATION

Specifies that materialized query table *table-name* can be used in query optimization. If the fullselect specified for the materialized query table does not satisfy the restrictions for automatic query optimization, an error occurs. For detailed rules to satisfy query optimization, see “CREATE TABLE statement” on page 1650.

DISABLE QUERY OPTIMIZATION

Specifies that materialized query table *table-name* cannot be used for query optimization. The table can still be queried directly.

Use of this clause or keyword might invalidate packages that depend on the target object, or packages that depend on related objects through cascading effects. See [Changes that invalidate packages \(Db2 Application programming and SQL\)](#).

DROP MATERIALIZED QUERY

DROP MATERIALIZED QUERY

Changes a materialized query table so that it is no longer considered a materialized query table. The table specified by *table-name* must be defined as a materialized query table. The definition of columns and data of the name are not changed, but the table can no longer be used for query optimization and is no longer valid for use with the REFRESH TABLE statement.

Use of this clause or keyword might invalidate packages that depend on the target object, or packages that depend on related objects through cascading effects. See [Changes that invalidate packages \(Db2 Application programming and SQL\)](#).

DATA CAPTURE

DATA CAPTURE

Specifies whether the logging of the following actions on the table includes additional information to support data replication processing:

- SQL data change operations
- Adding columns (using the ADD COLUMN clause)
- Changing columns (using the ALTER COLUMN clause)

For more information, see [Altering a table to capture changed data \(Db2 Administration Guide\)](#).

NONE

Do not record additional information to the log.

CHANGES

Write additional data about SQL updates to the log. Information about the values that are represented by any LOB or XML columns is not available. Do not specify DATA CAPTURE CHANGES for tables that reside in table spaces that specify NOT LOGGED.

The DATA CAPTURE CHANGES clause can be specified for a table for which row access controls or column access control are active. However, the access controls do not protect data that is written to the log.

For details about the recording of additional data for logged updates to catalog tables, see [“ALTER SEQUENCE statement” on page 1224](#).

VOLATILE

VOLATILE or NOT VOLATILE

Specifies how Db2 is to choose access to the table.

VOLATILE

Specifies that Db2 is to use index access to the table whenever possible for SQL operations. However, be aware that list prefetch and certain other optimization techniques might be disabled when VOLATILE is used.

One instance in which you might want to use VOLATILE is for a table whose size can vary greatly. If statistics are taken when the table is empty or has only a few rows, those statistics might not be appropriate when the table has many rows.

Another instance in which you might want to use VOLATILE is for a table that contains groups of rows, as defined by the primary key on the table. All but the last column of the primary key of such

a table indicate the group to which a given row belongs. The last column of the primary key is the sequence number indicating the order in which the rows are to be read from the group. VOLATILE maximizes concurrency of operations on rows within each group, since rows are usually accessed in the same order for each operation. For this usage, the primary index must be the only index that is defined on the table, and list prefetch is disabled to ensure the sequence in which the rows are locked.

NOT VOLATILE

Specifies that Db2 is to base SQL access to the table on the current statistics.

CARDINALITY

An optional keyword that currently has no effect, but that is provided for Db2 family compatibility.

ADD CLONE

ADD CLONE *clone-table-name*

Specifies that a clone table, identified by *clone-table-name*, is created for the table that is being altered. The name, including any implicit or explicit qualifiers, must not identify a table, view, alias, or synonym that exists at the current server. The name must not identify a table that exists in the SYSPENDINGOBJECTS catalog table. The clone table is created in the same table space as the base table and has the same structure as the base table. This includes, but is not limited to, column names, data types, null attributes, check constraints, indexes. When ADD CLONE is used to create a clone of the specified base table, the base table must conform to the following rules:

- Reside in a universal table space that is managed by Db2.
- If the table space or any of its dependent objects (LOBs, XMLs, or indexes) is created with the DEFINE NO clause, all data sets must already be created
- Be the only table in the table space
- Not be defined with a clone table
- Not be defined to use hash organization.
- Not be involved in any referential constraint
- Not be defined with any after triggers
- Not be a materialized query table
- Not have any pending changes
- Not have more than one table space version or index version in use. For information about how to remove in-use versions, see [Removing in-use table space versions \(Db2 Administration Guide\)](#) and [Recycling index version numbers \(Db2 Administration Guide\)](#).
- Not be a created global temporary table or a declared global temporary table
- Not be a system-period temporal table or a history table
- Not be an archive-enabled table or an archive table
- Not be altered to a clone table, if the base table uses relative numbering

The base table and the clone table are considered unrelated with regard to access controls. Row access control or column access control can be activated independently for the base table, the clone table, or both. The ownership can be transferred independently for the base table and the clone table.

DROP CLONE

DROP CLONE

Specifies that the clone table that is associated with the specified base table is dropped. *table-name* must identify a base table that exists at the current server and the table must have a clone table defined.

When a clone table is dropped, any row permissions or column masks that are defined for the clone table are also dropped. If the clone table is referenced in the definition of a row permission or a column mask, the ALTER statement returns an error

RESTRICT ON DROP

ADD RESTRICT ON DROP

Restricts dropping the table and the database and table space that contain the table.

DROP RESTRICT ON DROP

Removes the restriction on dropping the table and the database and table space that contain the table.

ROW ACCESS CONTROL

ACTIVATE ROW ACCESS CONTROL

Specifies that row access control should be activated for the table. If the table is an alias or a synonym, row access control is activated for the base table.

The table must not be one of the following tables:

- A created temporary table
- A table that is directly or indirectly referenced in the definition of a materialized query table
- A table that has a security label column
- A system-period temporal table
- A history table
- An archive-enabled table
- An archive table
- A table that has been granted federated access to another Db2 for z/OS subsystem in IBM Db2 Analytics Accelerator

If a trigger exists for the table, the trigger must be defined with the SECURED clause.

The table must not be referenced in the definition of a view if the following conditions are true:

- The view is defined with the WITH CHECK OPTION clause
- An INSTEAD OF trigger exists for the view and the trigger is not defined with the SECURED clause.

A default row permission is implicitly created for the table and allows no access to any of the rows of the table, unless there is another row permission that is enabled and that provides access for the authorization IDs or roles that are specified in the definition of the row permission. A query that references the table before such a row permission exists and is enabled will return a warning that there is no data in the table.

ACTIVATE ROW ACCESS CONTROL must not be specified if a period is defined for the table, because a default row permission cannot be defined for a table with a period specification.

When the table is referenced in a SELECT, INSERT, UPDATE, DELETE, or MERGE statement, all row permissions that are enabled for the table, including the default row permission, are applied to control the set of rows that are accessible for the table. If any row permission that is enable is invalid because a previous attempt to regenerate the row permission was unsuccessful, row access control cannot be activated.

ACTIVATE ROW ACCESS CONTROL is ignored if row access control is already activated for the table.

Use of this clause or keyword might invalidate packages that depend on the target object, or packages that depend on related objects through cascading effects. See [Changes that invalidate packages \(Db2 Application programming and SQL\)](#).

DEACTIVATE ROW ACCESS CONTROL

Specifies that row access control for the table is deactivated. When the table is referenced in a SELECT, INSERT, UPDATE, DELETE, or MERGE statement, any existing row permissions for the table that are enable are not applied to control the set of rows that are accessible for the table.

DEACTIVATE ROW ACCESS CONTROL is ignored if row access control is already defined as not activated for the table.

Use of this clause or keyword might invalidate packages that depend on the target object, or packages that depend on related objects through cascading effects. See [Changes that invalidate packages \(Db2 Application programming and SQL\)](#).

COLUMN ACCESS CONTROL

ACTIVATE COLUMN ACCESS CONTROL

Specifies that column access control should be activated for the table. If the table is an alias or a synonym, column access control is activated for the base table.

The table must not be one of the following tables:

- A created temporary table
- A table that is directly or indirectly referenced in the definition of a materialized query table
- A system-period temporal table
- A history table
- An archive-enabled table
- An archive table
- A table that has been granted federated access to another Db2 for z/OS subsystem in IBM Db2 Analytics Accelerator

If a trigger exists for the table, the trigger must be defined with the SECURED clause.

The table must not be referenced in the definition of a view if the following conditions are true:

- The view is defined with the WITH CHECK OPTION clause
- An INSTEAD OF trigger exists for the view and the trigger is not defined with the SECURED clause.

When column access control is activated, access to the table is not restricted. However, when the table is referenced in a SELECT, INSERT, UPDATE, DELETE, or MERGE statement, all column masks that are enabled for the table are applied to mask the values that are returned for the columns that are referenced in the final result table or to determine the new values that are used in the SQL data change statements. If any enabled column mask is invalid because a previous attempt to regenerate it was unsuccessful, column access control cannot be activated.

ACTIVATE COLUMN ACCESS CONTROL is ignored if column access control is already activated for the table.

Use of this clause or keyword might invalidate packages that depend on the target object, or packages that depend on related objects through cascading effects. See [Changes that invalidate packages \(Db2 Application programming and SQL\)](#).

DEACTIVATE COLUMN ACCESS CONTROL

Specifies that column access control for the table is deactivated. When the table is referenced in a SELECT, INSERT, UPDATE, DELETE, or MERGE statement, any existing column masks that are enabled for the table are not applied to control the values that are returned for the columns that are referenced in the final result table or to determine if the new values can be used in the SQL data change statements.

DEACTIVATE COLUMN ACCESS CONTROL is ignored if column access control is already defined as not activated for the table.

Use of this clause or keyword might invalidate packages that depend on the target object, or packages that depend on related objects through cascading effects. See [Changes that invalidate packages \(Db2 Application programming and SQL\)](#).

APPEND

APPEND NO or APPEND YES

Specifies whether append processing is used for the table. The APPEND clause must not be specified for a table in a work file table space.

If the base table is in a partition-by-range table space, the APPEND option on the LOB table might be different for each partition (depending if the LOB table space and associated objects for each partition are created explicitly or implicitly). If the base table is in a partition-by-growth table space, the APPEND attributes of LOB table will be inherited by each partition.

NO

Specifies that append processing is not used for the table. For insert and LOAD operations, Db2 attempts to place data rows in a well clustered manner with respect to the value in the row's cluster key columns.

YES

Specifies that data rows are placed into the table without regard to clustering during the insert and LOAD operations.

AUDIT

AUDIT

Alters the auditing attribute of the table. For information about audit trace classes, see [Audit trace \(Db2 Performance\)](#).

NONE

Specifies that no auditing is to be done when the table is accessed.

CHANGES

Specifies that auditing is to be done when the table is accessed during the first insert, update, or delete operation. However, the auditing is done only if the appropriate audit trace class is active.

ALL

Specifies that auditing is to be done when the table is accessed during the first operation of any kind performed by a utility or application process. However, the auditing is done only if the appropriate audit trace class is active and the access is not performed with COPY, RECOVER, REPAIR, or any stand-alone utility.

The ALTER TABLE statement is audited for successful and failed attempts in the following cases, if the appropriate audit trace class is active:

- AUDIT attribute is changed to NONE, CHANGES, or ALL on an audited or non-audited table.
- AUDIT CHANGES or AUDIT ALL is in effect.

VALIDPROC

VALIDPROC

Names a validation procedure for the table or inhibits the execution of any existing validation procedure.

program-name

Designates *program-name* as the new validation exit routine for the table.

The validation procedure can inhibit a data change operation on any row of the table. Before the operation takes place, the row is passed to the procedure. The values that are represented by any LOB or XML columns in the table are not passed to the validation procedure. On an insert or update operation, if the table has a security label column and the user does not have write-down privilege, the user's security label value is passed to the validation routine as the value of the column. After examining the row, the procedure returns a value that indicates whether the operation should proceed. A typical use is to impose restrictions on the values that can appear in various columns.

A table can have only one validation procedure at a time. When you name a new procedure, any existing procedure is no longer used. The new procedure is not used to validate existing table rows. It is used only to validate rows that are loaded, inserted, updated, or deleted after execution of the ALTER TABLE statement.

For more information, see [Validation routines \(Db2 Administration Guide\)](#).

NULL

Discontinues the use of any validation routine for the table.

ENABLE ARCHIVE

ENABLE ARCHIVE

Specifies that the table is an archive-enabled table.

The table must satisfy the following criteria:

- The table must not already be defined as an archive-enabled table or an archive table.
- The table must not contain a period.
- The table must be the only table in the table space.
- The table must not have a column mask or row permission defined.
- The table must not be one of the following tables:
 - A materialized query table
 - An incomplete table
 - An auxiliary table
 - A table that is involved in a clone relationship
 - A table that was implicitly created for an XML column
 - A table that contains a security label column
 - A system-period temporal table
 - A history table

ENABLE ARCHIVE must not be specified with other clauses on the ALTER TABLE statement.

The privilege set must include the privileges to issue an ALTER TABLE statement for the associated archive table.

For archive-enabled tables, Db2 retains archived versions of the rows. When data in an archive-enabled table is deleted, and the SYSIBMADM.MOVE_TO_ARCHIVE built-in global variable is set to Y, the last version of the row is inserted into the archive table.

The SYSIBMADM.GET_ARCHIVE built-in global variable and the ARCHIVESENSITIVE bind option determine whether rows in the associated archive table are included when an archive-enabled table is referenced in a *table-reference*.

Related information

[Archive-enabled tables and archive tables \(Introduction to Db2 for z/OS\)](#)

[“GET_ARCHIVE” on page 330](#)

[“MOVE_TO_ARCHIVE” on page 332](#)

[ARCHIVESENSITIVE bind option \(Db2 Commands\)](#)

USE *archive-table-name*

Specifies an archive table in which to keep archived rows of the archive-enabled table.

archive-table-name must identify a table that exists at the current server. The table must satisfy the following criteria:

- The table must be the only table in the table space.
- The table must not have an incomplete table definition.
- The table must not be defined as the parent or child in an existing referential constraint.
- The table must not include a period.
- The table must not include a row permission or column mask.
- The table cannot be one of the following tables:

- A catalog table.
- An archive-enabled table. The table was defined as an archive-enabled table by a previous statement, or the current statement defines the table as an archive-enabled table.
- An existing archive table.
- A system-period temporal table.
- A history table.
- A declared global temporary table.
- A created global temporary table.
- A materialized query table.
- A view.
- An auxiliary table.
- A table that was implicitly created for an XML column.
- A clone table.
- A table that has a clone defined on it.
- The table must not contain any of the following columns:
 - An identity column
 - A row-begin column
 - A row-end column
 - A transaction-start-ID column
 - A generated expression column
 - A security label column

The privilege set must include the privileges to issue an ALTER TABLE statement for the associated archive table.

The archive-enabled table and the associated archive table must have the same number and order of columns. The following attributes for the corresponding columns of the two tables must be the same:

- Name
- Data type
- Length (excluding inline LOB length or XML length in the base table), precision, and scale
- FOR BIT, SBCS, or MIXED DATA attribute for character string columns
- Null attribute
- Hidden attribute
- CCSID
- Field procedure

If a column of an archive-enabled table is defined as ROWID, the corresponding column of the archive table must also be defined as ROWID with the GENERATED ALWAYS attribute.

If a column of an archive-enabled table is defined as row change timestamp, the corresponding column of the archive table must also be defined as row change timestamp with the GENERATED ALWAYS attribute.

DISABLE ARCHIVE

DISABLE ARCHIVE

Specifies that the table is no longer an archive-enabled table.

table-name must identify an archive-enabled table. The definition of the columns and data of the table *table-name* are not changed, but the table is no longer treated as an archive-enabled table.

The relationship between the archive-enabled table and the associated archive table is removed. The

archive table is not dropped. However, by removing the relationship between the archive table and the archive-enabled table, the behavior of the archive-enabled table changes as follows:

- Subsequent queries that reference the table do not consider rows in the archive table regardless of the setting of the SYSIBMADM.GET_ARCHIVE built-in global variable or the ARCHIVESENSITIVE bind option.
- Deleted rows are not moved to the archive table regardless of the setting of the SYSIBMADM.MOVE_TO_ARCHIVE built-in global variable.

Use of this clause or keyword might invalidate packages that depend on the target object, or packages that depend on related objects through cascading effects. See [Changes that invalidate packages \(Db2 Application programming and SQL\)](#).

DISABLE ARCHIVE must not be specified with any other clauses on the ALTER TABLE statement.

The privilege set must include the privileges to issue an ALTER TABLE statement for the associated archive table

Notes for ALTER TABLE

Order of processing of clauses

When there is more than one clause, they are processed in the following order:

1. VALIDPROC
2. AUDIT
3. DATA CAPTURE
4. ROTATE
5. VOLATILE clauses
6. APPEND clauses
7. DROP clauses
8. ALTER clauses
9. RENAME clause
10. ADD clauses

Within each of these stages, the order in which the user specifies the clauses is the order in which they are performed.

Altering the data type, length, precision, or scale of a column

When you change the data type, length, precision, or scale of a column, consider the following information:

Altering character data

When columns are converted from CHAR to VARCHAR, normal assignment rules apply, which means that trailing blanks are kept instead of being stripped out. If you want varying length character strings without trailing blanks, use the STRIP function for data in the column after changing the data type to VARCHAR.

When a CHAR FOR BIT DATA column is converted to a BINARY data type, the following applies:

- The existing space characters in the table will not be changed to hexadecimal zeros (X'00')
- If the new length attribute is greater than current length attribute of the column, the values in the table are padded with hexadecimal zeros (X'00')

When a CHAR FOR BIT DATA or VARCHAR FOR BIT DATA column is converted to a BINARY or VARBINARY data type, the existing default value will be cast as a binary string. The resulting binary string will be at least twice the original size. The alter will fail if the resulting binary string length exceeds 1536 UTF-8 bytes.

Altering fixed-length to varying-length or increasing varying-length column

When you change a column from a fixed to varying length or change the length of a varying-length column, process the ALTER TABLE statements in the same unit of work or do a reorganization between the ALTER TABLE statements to avoid anomalies with the lengths and padding of individual values

Altering DECIMAL(19,0) to BIGINT.

In releases of Db2 prior to DB2 9, use of the DECIMAL(19,0) data type for applications that work with BIGINT data was encouraged. For performance reasons, columns it is best to alter the DECIMAL(19,0) columns to BIGINT. Note that altering from DECIMAL(19,0) to BIGINT is provided only for DECIMAL(19,0) columns that are used for applications that work with BIGINT (thus, the data in those columns is within the range of the BIGINT).

When altering from DECIMAL(19,0) to BIGINT you should ensure that all values in the DECIMAL(19,0) column are within the range of BIGINT before the alter. The following query or a similar query can be run to determine which rows (if any) contain values that are outside of the range of BIGINT:

```
SELECT * FROM table_name
WHERE dec19_0_column > 9223372036854775807
OR dec19_0_column < -9223372036854775808;
```

Altering a column in a partitioning key

When a partitioning key column with a numeric data type is altered to a larger numeric data type, and the limit key value for the original numeric data type of the column is X'FF', the limit key value for the new numeric data type of the column is left-padded with X'FF'. For example, if a column is converted from SMALLINT to INTEGER, and a limit key value for the SMALLINT column is 32767 (which is 2 bytes of X'FF'), the limit key for the INTEGER column is 2147483647 (which is 4 bytes of X'FF').

When a partitioning key column with a character data type is altered to a longer character data type, and the limit key value for the original character data type of the column (excluding the first NULL byte if the column is nullable) is neither all X'FF' nor all X'00', the limit key value for the new character data type of the column is right-padded with blank(s) of the encoding scheme of the table. For example, if a column is converted from CHAR(1) to VARCHAR(2), and a limit key value for the CHAR(1) column is 'A' (which is X'C1'), the limit key for the VARCHAR(2) column is 'A ' (which is X'C140' when the encoding scheme of the table is EBCDIC, or is X'C120' when the encoding scheme of the table is UNICODE or ASCII).

When a partitioning key column with a character data type is altered to a longer character data type, and the limit key value for the original character data type of the column (excluding the first NULL byte if the column is nullable) is all X'FF', the limit key value for the new character data type of the column is right-padded with X'FF' and the table space that contains the table being altered is left in REORG-pending (REORP) status.

When a partitioning key column with a character data type is altered to a longer character data type, and the limit key value for the original character data type of the column (excluding the first NULL byte if the column is nullable) is all X'00', the limit key value for the new character data type of the column is right-padded with X'00' and the table space that contains the table being altered is left in REORG-pending (REORP) status.

Statistics for altered columns

New COLUMN statistics should be collected for all altered columns. Even though the COLCARDF value is valid, the HIGH2KEY and LOW2KEY values are invalid, and any SYSCOLSTATS catalog entries for the column are removed. Any frequencies or histogram statistics which include this column should also be collected again.

Considerations for altering an XML column

If *altered-data-type* is XML, the old data type of the altered column must also be XML:

- If the old data type has no XML type modifier and the new data type does, you should ensure that all values in the XML column are valid according to the XML schema that is specified in the type modifier. The XML table space for the column that is being changed is left in CHECK-pending status.
- If the old data type has the XML type modifier but the new data type has no type modifier, the existing values do not need to be re-validated. The state of the table space is not changed.

If the XML schemas that are specified in the old XML type modifier are a subset of the XML schemas that are specified in the new XML type modifier, the existing values do not need to be re-validated. The state of the XML table space is not changed.

- If the XML schemas that are specified in the old XML type modifier are NOT a subset of the XML schemas that are specified in the new XML type modifier, the XML table space for the column that is being changed is left in the CHECK-pending status.

Recovering to a point in time after an alteration

Some alterations might affect subsequent requests to recover to a point in time. For details about possible restrictions, effects on recovery status, and other considerations, see [Point-in-time recovery \(Db2 Utilities\)](#).

For example, for an ALTER TABLE statement that includes a DROP COLUMN, ALTER COLUMN, or ROTATE PARTITION clause, certain considerations or restrictions might apply to subsequent requests to recover to a point in time.

Referencing columns in ADD, ALTER, and RENAME clauses

A column can only be referenced once in an ADD COLUMN, an ALTER COLUMN, or a RENAME COLUMN clause in a single ALTER TABLE statement. However, that same column can be referenced multiple times for adding or dropping constraints in the same ALTER TABLE statement.

Because a distinct type is subject to the same restrictions as its source type, all the syntactic rules that apply to LOB, ROWID, and DECFLOAT columns apply to distinct type columns that are based on LOBs, row IDs, and DECFLOATs. For example, if a table has an explicitly created ROWID column, you cannot add a column with a distinct type that is sourced on a row ID.

Adding a column to table T only changes the description of T. If the catalog description of T is used to create a table T' and a facility such as DSN1COPY is used to effectively copy T into T', queries that refer to the added column in T' will fail because the data does not match its description. To avoid this problem, run the REORG utility against the table space of T before making the copy.

Restrictions on a clone table

Tables that are involved in a clone relationship (base tables and their associated clone tables) have the following restrictions:

- You cannot use the RUNSTATS utility on a clone table.
- Objects that are involved in a clone relationship do not use the FASTSWITCH data set switching method when the REORG utility is run and the switch phase happens normally. This includes both the base table and the clone table objects (data and index), as well as LOB and XML objects. In addition, specification of FASTSWITCH YES together with CLONE in a REORG utility control statement is not allowed.
- For a partitioned table, if a mixture of 'I' and 'J' data sets exists when a clone table is created, the mixture of 'I' and 'J' data sets can be changed only by first dropping the clone table.
- Catalog and directory tables cannot have clone tables.
- Indexes cannot be created on a clone table. When an index is created on a base table that is involved in a clone relationship, the index on the clone table will be created implicitly and will be put into rebuild-pending status.
- Implicitly created auxiliary table spaces (table spaces for LOB and XML columns) and auxiliary indexes for the base table are always created as DEFINE YES.
- Before triggers cannot be created on a clone table. Before triggers that are created on a base table apply to both the base table and the clone table.
- You cannot rename a base table that has a clone and you cannot rename a clone table.

- Real-time statistics tables cannot have clone tables.
- You cannot drop an auxiliary table or an auxiliary index of an object that is involved in a clone relationship.

If the table is involved in a clone relationship, no other table altering can take place. If a table change is required, the clone table objects must be dropped so that the base table object attributes can be modified. After the table and index changes and such are completed, the clone table objects can be recreated.

Size restriction for the object descriptor of a table

The following cases might result in an error being returned if the ALTER TABLE statement results in a versioned object descriptor that is larger than 30,000 bytes being added (or updated):

- An ALTER TABLE statement that results in the first version of the object descriptor being generated for the table
- An ALTER TABLE statement that results in the first version of the object descriptor being generated for one or more of the indexes that are defined on the table
- An ALTER TABLE ALTER COLUMN SET DATA TYPE statement on an existing decimal column on a versioned table

You might need to drop and recreate the table if the object descriptor for the table exceeds 30,000 bytes. Alternatively, you can reduce the size of the object descriptor for the table by reducing the size of the default value for varying-length columns in the table by issuing an ALTER TABLE ALTER COLUMN SET DEFAULT statement. You can also drop unnecessary column defaults to reduce the size of the object descriptor for the table.

Altering the attributes of an existing identity column

Existing values for the identity column are unaffected by the ALTER TABLE statement. The changed identity column attributes affect values generated after the ALTER statement has executed. Db2 does not validate any of the existing identity column values against the new identity column attributes. For example, duplicate values might be generated even if NO CYCLE is in effect, such as when an ascending identity column altered to become a descending identity column.

Any existing values in the cache that have not yet been used might be lost. Loss of cached values can also occur if the ALTER statement returns an error or is rolled back.

Specifying START or RESTART WITH values outside the range for cycles for identity columns

START or RESTART WITH values for identity columns are not constrained by the values of MINVALUE and MAXVALUE. That is, if the START WITH or RESTART WITH value for an identity column is greater than MAXVALUE, it has the following results:

- An ascending identity column generates the RESTART WITH value and then cycles to MINVALUE if CYCLE is in effect. If NO CYCLE is in effect, the identity column generates the RESTART WITH value one time, and the next attempt to generate an identity column value returns an error.
- A descending sequence generates the RESTART WITH value and then generates values according to the INCREMENT BY specification until it reaches MINVALUE. MAXVALUE does not constrain the generation of values for a descending identity column in this situation, so many values greater than MAXVALUE can potentially be generated.

Likewise, if the RESTART WITH value is less than MINVALUE, it has the following results:

- A descending identity column generates the RESTART WITH value and then cycles to MAXVALUE if CYCLE is in effect. If NO CYCLE is in effect, the sequence generates the RESTART WITH value one time, and the next attempt to generate a sequence value returns an error.
- An ascending identity column generates the RESTART WITH value and then generates values according to the INCREMENT BY specification until it reaches MAXVALUE. MINVALUE does not constrain the generation of values for an ascending identity column in this situation, so many values less than MINVALUE can potentially be generated.

Pending data definition changes

The following table lists clauses and specific conditions that cause an ALTER TABLE statement to be processed as a pending definition change, which is not reflected in the definition or data at the time that the ALTER TABLE statement is issued. Instead, the table space or specific partitions are placed in an advisory REORG-pending state (AREOR). A subsequent reorganization of the table space, or the specific affected partitions, applies the pending definition changes to the definition and data of the table. The definition of the containing table space must not be in an incomplete state.

Clause or option	Pending definition change used if..
ALTER COLUMN	<p>The statement altering the data type, length, precision, or scale of a column is a pending change to the definition of the table space if the data sets of the table space are already created and all of the following conditions are true:</p> <ul style="list-style-type: none"> • The DDL_MATERIALIZATION subsystem parameter is set to ALWAYS_PENDING. • The base table space is a universal table space.
DROP COLUMN	The data sets of the table space are already created.
ADD PARTITION	<p>The data sets are already defined and the new partition is added between existing logical partitions.</p> <p>The alteration is normally a pending change, and the added partition is placed in advisory REORG-pending (AREOR) status. Unless integer specifies the last logical partition, the next logical partition is also placed in AREOR status. However, if no other pending definition changes exist on the affected partitions, an immediate change can sometimes be used, possibly with a restrictive status.</p>
ALTER PARTITION	<p>The statement changes the limit keys for the following types of partitioned table spaces:</p> <ul style="list-style-type: none"> • Partition-by-range table spaces • Partitioned (non-UTS) table spaces with table-controlled partitioning. <p>The alteration is normally a pending change, and the altered partition is placed in advisory REORG-pending (AREOR) status. Unless integer specifies the last logical partition, the next logical partition is also placed in AREOR status. However, if no other pending definition changes exist on the affected partitions, an immediate change can sometimes be used, possibly with a restrictive status.</p> <p>The change is immediate with no restrictive status if any of the following conditions are true:</p> <ul style="list-style-type: none"> • The affected partition data sets never contained any data. • There is no possibility of any data being discarded or moved between partitions based only on the range of possible data values (not on the actual data values). This situation can occur if the statement specifies the same existing values for the limit key, or if the new limit key for the last logical partition expands the range of possible data values.
The data sets of the table space are already created.	

For more information, see [Pending data definition changes \(Db2 Administration Guide\)](#).

Restrictions for pending data definition changes

The following restrictions apply to ALTER TABLESPACE, ALTER TABLE, and ALTER INDEX statements that result in pending data definition changes:

- Options that cause pending changes cannot be specified with options that take effect immediately.
- Options that cause pending changes cannot be specified for the Db2 catalog, other system objects, or objects in a work file database.
- The DROP PENDING CHANGES clause of the ALTER TABLESPACE statement cannot be specified for a catalog table space.
- If the table space, or any table it contains is in an incomplete state, you cannot specify options that cause pending changes.
- For ALTER INDEX, options that cause pending changes cannot be specified if the definition of the table space or table on which the index is defined is not complete.

Also, many alter operations are restricted for a table space that has existing pending data definition changes for the table space, the table it contains, or indexes on the table. For more information, see [Restrictions for pending data definition changes \(Db2 Administration Guide\)](#).

Adding a LOB column

Db2 sometimes implicitly creates the LOB table space, auxiliary table, and index on the auxiliary table for each LOB column in a table or partition. For more information, see [LOB table space implicit creation \(Db2 Administration Guide\)](#).

If Db2 does not implicitly create the LOB table spaces, auxiliary tables, and indexes on the auxiliary tables, you must create these objects by issuing CREATE TABLESPACE, CREATE AUXILIARY TABLE, and CREATE INDEX statements. For more information, see [Creating LOB table spaces, auxiliary tables, and auxiliary indexes explicitly \(Db2 Administration Guide\)](#).

For partitioned tables, each partition of the base table requires a separate LOB table space, auxiliary table, and auxiliary index for each LOB column.

If the base table is involved in a clone relationship, implicitly created LOB table spaces and implicitly created indexes are always created with the DEFINE YES attribute.

Adding an inline LOB column

If the page size is exceeded for a table in a universal table space, Db2 recalculates the record size using 0 as the inline length for LOB columns that do not specify the INLINE LENGTH clause. A record size of 0 is used in the recalculation even if the LOB_INLINE_LENGTH subsystem parameter value is greater than 0. After the recalculation, if the page size is still exceeded, the ALTER TABLE statement returns an error.

Adding a ROWID column

When you add a ROWID column to an existing table, Db2 ensures that the same, unique row ID value is returned for a row whenever it is accessed. If the table already has an implicitly hidden ROWID column, Db2 also ensures that the values in the two ROWID columns are identical.

If the table space that contains the table is implicitly created and you add a ROWID column that is defined as GENERATED BY DEFAULT to the table, an enforcing index for the ROWID column is implicitly created. If the table already has an implicitly hidden ROWID column and the ROWID column that you add is defined as GENERATED BY DEFAULT, Db2 changes the implicitly hidden ROWID column to have the GENERATED BY DEFAULT attribute and does not implicitly create an enforcing index for the ROWID column.

When you add a ROWID column that is defined as GENERATED BY DEFAULT and the ROWID index is implicitly created, the privilege set requires the INDEX privilege on the table and the USE privilege on the buffer pool and the storage group. The implicitly created ROWID index is owned by the owner of the table.

Reorganizing a table space has no effect on the values in a ROWID column.

Adding an identity column

When you add an identity column to a table that is not empty, Db2 places the table space that contains the table in the REORG pending (REORP) status. When the REORG utility is subsequently run, Db2 generates the values for the identity column in all existing rows and then removes the REORG-pending (REORP) status. These values are guaranteed to be unique, and their order is system-determined.

Adding a row change timestamp column

When you add a row change timestamp column to an existing table, the initial value for existing rows is not stored at the time of the ALTER statement.

APPLCOMPAT V13R1M502 or lower: If the ALTER statement was executed in APPLCOMPAT V13R1M502 or lower, then the LRSN or the RBA derive an implicit ROW CHANGE TIMESTAMP expression for the row change timestamp column values in existing rows.

Db2 places the table space into an advisory-REORG pending state. For existing rows' row change timestamp column values, the LRSN or the RBA derives an implicit ROW CHANGE TIMESTAMP expression. When any row on the page is updated or changed, the implicit ROW CHANGE TIMESTAMP expression is changed. When the REORG utility is subsequently run, Db2 generates the values for the row change timestamp column in all existing rows and then removes the REORG pending status. These values will not change unless the row is updated.

XML version support when adding an XML column

When an XML column is added to a table that is in a universal table space, the XML column and the associated XML table will support XML versions if it is the first XML column in the table or if all the other XML columns in the table support XML versions. Similarly, when a clone table is associated with the base table, any XML columns and associated XML tables will support XML versions if the existing XML columns in the base table support XML versions.

Effect of adding a column on views

Adding a column to a table has no effect on existing views.

Considerations for implicitly hidden columns

A column that is defined as implicitly hidden can be explicitly referenced on the ALTER statement. For example, an implicitly hidden column can be altered, can be specified as part of a referential constraint or a check constraint, or a materialized query table definition.

Cascaded effects of adding or altering a column

Adding a column to a table has no cascaded effects to views that reference the table. For example, adding a column to a table does not cause the column to be added to any dependent views, even if those views were created with a SELECT clause. But altering a column can cause other cascaded effects. The following table lists the cascaded effect of altering the data type, precision, scale, or length of a column.

Table 183. Cascaded effect of altering a column's data type, precision, scale, or length

Operation	Effect
Alter of a column referenced by a view	If the data type, length, precision, or scale for a column is altered, all the views that are dependent on the altered table are reevaluated at alter time with the new column attributes. If errors are encountered during the view regeneration process, the ALTER TABLE statement fails. The new internal structure of each dependent view is not saved at alter time, and subsequent references to a dependent view will cause the view to be regenerated again. Use the ALTER VIEW statement to regenerate a dependent view and have the new internal structure saved.

Table 183. Cascaded effect of altering a column's data type, precision, scale, or length (continued)

Operation	Effect
Alter of a column referenced in the key of an index or a unique constraint (unique key or primary key)	The alter is allowed unless DECIMAL with a fraction is being converted to a floating value. In this case, the loss of precision can result in a loss of uniqueness. For numeric data type conversions, the index is placed in REBUILD-pending status. For character data type conversions, the index key columns are converted on first-write access. The index is not placed in REBUILD-pending status.
Alter of a column referenced in a package	The alter is allowed. All packages dependent on the table in which the column is being altered are invalidated.
Alter of a column referenced in the body of a user-defined function or procedure	Alter is allowed. If there is a package associated with the function or procedure, it is invalidated. If the function is an SQL table function, the function is reevaluated at alter time with the new column attributes. If errors are encountered during the reevaluation process, the ALTER TABLE statement fails.
Alter of a column referenced in the parameter list of a user-defined function or procedure	Alter is allowed. The attributes of the existing function or procedure are unchanged. To access the new definition of the column, the function or procedure must be dropped and recreated. If the function is an SQL table function, the function is reevaluated at alter time with the new column attributes. If errors are encountered during the reevaluation process, the ALTER TABLE statement fails.
Alter of a column referenced by a trigger	Alter is allowed. All trigger packages that are dependent on the table of the column are invalidated. If the trigger is an advanced trigger, the trigger is regenerated, and a rebind occurs for the SQL control statements, as well as non-SQL control statements that are included in the trigger body, at the local server. When a trigger is regenerated, any unqualified names in the trigger body are resolved using the name resolution process.

Table 183. Cascaded effect of altering a column's data type, precision, scale, or length (continued)

Operation	Effect
Alter of a column referenced in a row permission or column mask	<p>Alter is allowed.</p> <p>Changing the data type, precision, scale, or length of a column can affect a row permission or a column mask that is defined on the table. If the data type, length, precision, or scale for the column is changed and a column mask is defined for this column, or a row permission or a column mask references this column, these row permissions and column masks are reevaluated using the new column attributes of the column. If an error is encountered during the reevaluation process, the ALTER statement returns the error.</p> <p>During the reevaluation of the column mask or row permission, user-defined functions that are referenced in the definition of the column mask or the row permission must be resolved to the same functions that were resolved during the creation of the column mask or the row permission.</p>

If the column that is being changed is part of an index, and the column alteration is executed as an immediate definition change, an exception state might be set for the index. Possible settings are shown in [Table 184 on page 1303](#):

Table 184. Informational settings for ALTER COLUMN when the column is in an index

Alteration type	Exception state for index
VARCHAR to CHAR	<ul style="list-style-type: none"> For a NOT PADDED index: PSRBD and AREO*, or RBDP and AREO*^{“1”} on page 1304 For a PADDED index: AREO*
VARGRAPHIC to GRAPHIC	<ul style="list-style-type: none"> For a NOT PADDED index: PSRBD and AREO*, or RBDP and AREO*^{“1”} on page 1304 For a PADDED index: AREO*
CHAR to VARCHAR	AREO*
GRAPHIC to VARGRAPHIC	AREO*
VARCHAR to VARCHAR	AREO* (for a PADDED index only)
VARGRAPHIC to VARGRAPHIC	AREO* (for a PADDED index only)
CHAR to CHAR	AREO*
CHAR FOR BIT DATA or VARCHAR FOR BIT DATA to BINARY or VARBINARY	RBDP or PSRBD ^{“1”} on page 1304
GRAPHIC to GRAPHIC	AREO*
Any changed numeric column	RBDP or PSRBD ^{“1”} on page 1304
TIMESTAMP WITHOUT TIME ZONE to TIMESTAMP WITHOUT TIME ZONE	AREO*

Table 184. Informational settings for ALTER COLUMN when the column is in an index (continued)

Alteration type	Exception state for index
TIMESTAMP WITH TIME ZONE to TIMESTAMP WITH TIME ZONE	AREO*

Notes:

1. An index on a nonpartitioned table, or a partitioned index on a partitioned table is set to RBDP status. A nonpartitioned index on a partitioned table is set to PSRBD status.

For information about resetting informational or restrictive exception states after schema changes, see [Reorganizing table spaces for schema changes \(Db2 Administration Guide\)](#).

Adding a partition

When you add a partition to a table, if the boundary for the last partition was not previously enforced, it is enforced after the partition is added, and the last two logical partitions are left in REORG-pending (REORP) status. If the last partition before the new one is added was in REORG-pending status, the added partition is also placed in REORG-pending status.

For more information, see [Adding partitions \(Db2 Administration Guide\)](#).

Adding a partition for a table that has LOB columns

Db2 sometimes implicitly creates the LOB table space, auxiliary table, and index on the auxiliary table for each LOB column in a table or partition. For more information, see [LOB table space implicit creation \(Db2 Administration Guide\)](#).

If Db2 does not implicitly create the LOB table spaces, auxiliary tables, and indexes on the auxiliary tables, you must create these objects by issuing CREATE TABLESPACE, CREATE AUXILIARY TABLE, and CREATE INDEX statements. For more information, see [Creating LOB table spaces, auxiliary tables, and auxiliary indexes explicitly \(Db2 Administration Guide\)](#).

Row format for newly added partitions

When the value of the RRF subsystem parameter is ENABLE, newly added partitions that are created using the ADD PARTITION clause (or partitions that are added because the table space is partition-by-growth) will be created in re-ordered row format. When the value of the RRF subsystem parameter is DISABLE, newly added partitions will be created in basic row format, except for the following table spaces:

- For table spaces that are already using basic row format and that contain tables with edit procedures, newly created partition will always be in basic row format regardless of value of the RRF parameter.
- For table spaces that are already using re-ordered row format and that contain tables with edit procedures, newly created partition will always be in re-ordered row format regardless of value of the RRF parameter.
- Newly created partitions of an XML table space will always be in re-ordered format.

Rotating a partition from first to last

Running ALTER TABLE to rotate the first logical partition to become the last logical partition can be very time consuming. During the reset operation, all rows from the partition are deleted. In addition, the keys for the deleted rows are also deleted from all nonpartitioned indexes, which requires that each nonpartitioned index must be scanned.

When you rotate partitions, if the boundary for the last partition was not previously enforced, it is enforced after ROTATE FIRST TO LAST is issued, and the last two logical partitions are left in REORG-pending (REORP) status. If the last partition before ROTATE FIRST TO LAST was issued was in REORG-pending status, the last two logical partitions are left in REORG-pending status.

Effect of changes on applications

Applications might need to be changed to correspond to changes to the columns in a table. For example, if you increase the length of a column, you need to increase the length of variables into which that column is fetched. If you change the data type of a column, you also might need to change the data type of the corresponding variable to avoid performance degradation.

If you rename or drop a column, you need to change any references to that column to avoid unexpected results.

Invalidation of packages

This statement might invalidate all packages that depend on target objects, and sometimes other related objects through cascading effects, depending on the clauses and keywords specified and other factors. For more information, see [Changes that invalidate packages \(Db2 Application programming and SQL\)](#).

Changes that might require rebinds to take effect for applications:

Some alterations that do not invalidate packages might still require rebinds of dependent packages for the applications to pick up the changes. For more information, see [Changes that might require package rebinds \(Db2 Application programming and SQL\)](#).

Dropping constraints and check pending status

If a table space or partition is in check pending status because it contains a table with rows that violate constraints, dropping the constraints removes the check pending status.

Altering materialized query tables

The ALTER TABLE statement can be used to register an existing table at the current server as a materialized query table, change the attributes of an existing materialized query table, or change an existing materialized query table into a base table.

The isolation level at the time when a base table is first altered to become a materialized query table by the ALTER TABLE statement is the isolation level for the materialized query table.

Altering a table to change it to a materialized query table with query optimization enabled makes the table eligible for use in query rewrite immediately. Therefore, pay attention to the accuracy of the data in the table. If necessary, the table should be altered to a materialized query table with query optimization disabled, and then the table should be refreshed and enabled with query optimization.

When a base table is altered into a materialized query table or a user-maintained query table is altered into a system-maintained one, the REFRESH_TIME column of the row for the table in SYSIBM.SYSVIEWS contains the current timestamp. When a system-maintained materialized query table is altered into a user-maintained materialized query table, the REFRESH_TIME column of the row for the table in SYSIBM.SYSVIEWS does not change.

The LOAD utility is not allowed on a system-maintained query table, but it is allowed on a user-maintained materialized query table.

Considerations for running utilities while altering tables

You cannot execute the ALTER TABLE statement while a utility has control of the table space that contains the table.

Restrictions on field procedures, edit procedures, and validation exit procedures

Field procedures, edit procedures that are defined as WITH ROW ATTRIBUTES, and validation exit procedures cannot be used on tables that have column names that are larger than 18 EBCDIC bytes. If you have tables that have field procedures or validation exit procedures and you add a column where the column name is larger than 18 bytes, the field procedures and validation exit procedures for the table are invalidated.

Consider using triggers to replace the functionality on field procedures, edit procedures that are defined as WITH ROW ATTRIBUTES, and validation exit procedures on tables where the column names are larger than 18 EBCDIC bytes.

Restrictions on SQL data change statements in the same commit scope as ALTER TABLE

SQL data change statements that affect an index cannot be performed in the same commit scope as ALTER TABLE statements that affect that index.

Restrictions on DATA CAPTURE CHANGES

If the table is in advisory REORG-pending state, you cannot alter the table to use the DATA CAPTURE CHANGES clause.

Capturing changes to the Db2 catalog

To have logged changes to a Db2 catalog table augmented with information for data capture, specify ALTER TABLE *xxx* DATA CAPTURE CHANGES where *xxx* is the name of a catalog table (SYSIBM.*xxx*). Data capture of catalog table changes provides the possibility of creating and managing a shadow of the catalog.

Restrictions for tables with dropped columns

Dropping of table columns is a pending definition change. A table space that contains a table with dropped columns cannot be recovered to a point in time before dropping of those columns was materialized.

Row access control that is activated explicitly

The ACTIVATE ROW ACCESS CONTROL clause is used to activate row access control for a table. When this happens, a default row permission is implicitly created and allows no access to any rows of the table, unless later another enabled row permission exists that provides access for the authorization IDs or roles that are specified in the definition of the permission. The default row permission is always enabled.

When the table is referenced in a data manipulation statement, all enabled row permissions that have been created for the table, including the default row permission, are implicitly applied by Db2 to control which rows in the table are accessible. A row access control search condition is derived by application of the logical OR operator to the search condition in each enabled row permission. This derived search condition acts as a filter to the table before any user specified operations such as predicates, grouping, ordering, etc. are processed. This derived search condition permits the authorization IDs or roles that are specified in the permission definitions to access certain rows in the table. See the description of subselect for information on how the application of enabled row permissions affects the fetch operation. See the data change statements for information on how the application of enabled row permissions affects the data change operation.

Row access control remains enforced until the DEACTIVATE ROW ACCESS CONTROL clause is used to stop enforcing it.

Implicit object that is created when row access control is activated for a table

When the ACTIVATE ROW ACCESS CONTROL clause is used to activate row access control for a table, Db2 implicitly creates a default row permission for the table. The default row permission prevents all access to the table. The implicitly created row permission is in the same schema of the base table and has a name in the form of SYS_DEFAULT_ROW_PERMISSION__*table-name* ... up to 128 UTF-8 bytes. Notice two underscores after "PERMISSION". If this name is not unique, the last 4 bytes are reserved for a unique number '*nnnn*', where '*nnnn*' is a four alphanumeric characters starting at '0000' and is incremented by 1 value each time until a unique name is found. The owner of the default row permission is SYSIBM.

The default row permission is always enabled.

The default row permission is dropped when row access control is deactivated or when the table is dropped.

Activating column access control

The ACTIVATE COLUMN ACCESS CONTROL clause is used to activate column access control for a table. The access to the table is not restricted but when the table is referenced in a data manipulation statement, all enabled column masks that have been created for the table are applied to mask the column values referenced in the final result table of the queries or to determine the new values used in the data change statements.

When column masks are used to mask the column values, they determine the values in the final result table. If a column has a column mask and the column (a simple reference to a column name or embedded in an expression) appears in the outermost select list, the column mask is applied to the column to produce the values for the final result table. If the column does not appear in the outermost select list but it participates in the final result table, for example, it appears in a materialized table

expression or view, the column mask is applied to the column in such a way that the masked value is included in the result table of the materialized table expression or view so that it can be used in the final result table.

The application of column masks does not interfere with the operations of other clauses within the statement such as the WHERE, GROUP BY, HAVING, SELECT DISTINCT, and ORDER BY. The rows returned in the final result table remain the same, except that the values in the resultant rows might have been masked by the column masks. As such, if the masked column also appears in an ORDER BY sort-key, the order is based on the original column values and the masked values in the final result table might not reflect that order; similarly, the masked values might not reflect the uniqueness enforced by SELECT DISTINCT. If the masked column is embedded in an expression, the result of the expression can become different because the column mask is applied on the column before the expression evaluation can take place. If the expression in a query is the same as the expression used to mask the column value in the column mask definition, the result of the expression in the query might remain unchanged. For example, the expression in the query is 'XXX-XX-' || SUBSTR(SSN, 8, 4) and the same expression appears in the column mask definition. In this particular example, the user can replace the expression in the query with column SSN to avoid the same expression gets evaluated twice.

The following are the contexts where the column masks are used by Db2 to mask the column values for the result of a query. Certain restrictions might apply to some contexts. Those restrictions are described in a separate list.

- The outermost SELECT clause of a SELECT or SELECT INTO statement, or if the column does not appear in the outermost select list but it participates in the final result table, the outermost SELECT clause of the corresponding materialized table expression or view where the column appears.
- The outermost SELECT clause of a SELECT FROM INSERT, UPDATE, DELETE, or MERGE statement
- The outermost SELECT clause that are used to derive the new values for an INSERT, UPDATE, or MERGE statement, or a SET *transition-variable* assignment statement
- The same applies to a scalar-fullselect expression that does not use set operators and appears in the outermost SELECT clause of the above statements, the right side of a SET variable assignment statement, the VALUES INTO statement, or the VALUES statement.
- The same applies to the SQL statements or the equivalences such as the assignment statement that appears in a native SQL procedure or a compiled user-defined SQL scalar function.

If a CASE expression appears in the above contexts, the column masks are not applied in the search conditions of the WHEN clauses.

A column mask is created as a stand-alone object without knowing all of the contexts in which it might be used. To mask a column value in the final result table, the column mask definition is merged into the statement by Db2. When the column mask definition is brought into the context of the statement, it might conflict with certain SQL semantics in the statement. Therefore, in some situations, the combination of the statement and the application of a column mask can return an error. The following describes when the error might be returned:

1. The column masks cannot be applied to the columns in the select lists that derive the final result table of set operations because one of the set operators that are used to derive the final result table is EXCEPT ALL, EXCEPT DISTINCT, INTERSECT ALL, or INTERSECT DISTINCT.
2. The column mask cannot be applied to the column in the select lists of a scalar-fullselect expression if the result of scalar-fullselect expression is derived from set operation EXCEPT or INTERSECT.
3. If the subselect contains a GROUP BY clause, the column mask cannot be applied to a column in the corresponding select list if none of the following conditions is satisfied:
 - The column must identify a *column-name* in the GROUP BY clause and the column must not be referenced in an expression in the GROUP BY clause. Furthermore, its column mask definition must satisfy the following condition:

- any columns that are referenced in the column mask definition that come from the same table of the column to which the column mask is applied must identify a column-name in the GROUP BY clause
 - the column mask must not be referenced in an expression in the GROUP BY clause
 - The column must be specified under an aggregate function and its column mask definition must satisfy the following conditions:
 - The column mask definition must not reference a scalar-fullselect
 - The column mask definition must not reference an aggregate function
4. If the subselect contains a GROUP BY clause, and a column in the corresponding select list maps directly or indirectly to a column name or an expression in a materialized table expression or view, the column in the subselect where the GROUP BY is specified must be specified under an aggregate function.
 5. If the subselect does not contain a GROUP BY clause, and a column in the corresponding select list is specified under an aggregate function, the column mask cannot be applied if the column mask definition references:
 - a scalar-fullselect
 - an aggregate function
 6. If the FROM clause in a subselect references a recursive common table expression, and if the result of the recursive common table expression is used to derive the final result table, the column mask cannot be applied to a column that is referenced in the fullselect of the recursive common table expression.
 7. If the FROM clause in a subselect contains a *data-change-table-reference*, and if an INCLUDE clause is specified as part of the SQL data change statement, the column mask cannot be applied to the columns that are used to derive the values for these additional columns in the outermost select list.
 8. If the FROM clause in a subselect references an external table user-defined function or an SQL table user-defined function, and if the result of the function is used to derive the final result table, the column mask cannot be applied to the column that is an argument of the function.
 9. If an OLAP specification is referenced in a select list that derives the final result table, the column mask cannot be applied to the column that is referenced in the partitioning expression or the sort key expression of the OLAP specification.
 10. If a user-defined function is defined with the NOT SECURED option, the argument of the function must not reference a column for which a column mask is enabled and the column access control is activated for its table. This rule applies to user-defined functions that are referenced anywhere in the statement.

To avoid the above error situations at bind time, one of the following actions must be taken:

- modify or remove the above contexts from the statement
- disable the column mask
- drop the column mask, modify the definition, and recreate the column mask
- deactivate the column access control for the table

In other situations, if the statement contains a SELECT DISTINCT, and a column mask is applied to a column that directly or indirectly derives the result of SELECT DISTINCT, the statement might return a result that is not deterministic. The following examples illustrate when such results might be returned:

1. If the column mask definition references other columns from the same table of the column to which the column mask is applied, the result of SELECT DISTINCT can not be deterministic.
2. If the column is referenced in the argument of built-in scalar functions (such as COALESCE, IFNULL, NULLIF, MAX, MIN, LOCATE, TOTALORDER), the result of SELECT DISTINCT might not be deterministic.

3. If the column is referenced in the argument of an aggregation function, the result of SELECT DISTINCT might not be deterministic. If DISTINCT is specified, the argument of the function must not reference a column with a column mask.
4. If the column is embedded in an expression and the expression contains a function that is not deterministic or has an external action, the result of SELECT DISTINCT might not be deterministic.

With UNION DISTINCT, the elimination of the duplicate rows is based on the unmasked values in R1 and R2. Because all rows are from R1 or R2, the output values in the result table of the union may vary when one or more of the following conditions occur:

- The expression corresponding to the *n*th column in R1 references columns with column masks, but the expression corresponding to the *n*th column in R2 does not, or vice versa.
- The expressions corresponding to the *n*th column in R1 and R2 reference columns with different column masks.
- The column mask definition references columns that are not the same target column for which the column mask is defined, and those columns are not part of the UNION DISTINCT operation. It is recommended that the column mask definition does not reference other columns from the target table.

For example, a row in R1 is derived from the masked value, and a row in R2 is derived from the unmasked value. If the row in the result table is from R1, the masked value is returned. If the row in the result table is from R2, the unmasked value is returned.

EXCEPT and INTERSECT can be intermixed with UNION if the rows in R1 and R2 for EXCEPT and INTERSECT do not reference columns with column masks

If the column is not nullable, most likely its column mask definition will not consider a null value for the column. After the column access control is activated for the target table, if the target table is the null-padded table in an outer join operation, the column value in the final result table might be a null.

When the columns are used to derive the new values for an INSERT, UPDATE, MERGE, or a SET transition-variable assignment statement, the original column values, not the masked values, are used. If the columns have column masks, those column masks are applied to ensure the evaluation of the access control rules at run time masks the column to itself, not to a constant or an expression. This is to ensure the masked values are the same as the original column values. If a column mask does not mask the column to itself, the existing row is not updated or the new row is not inserted and an error is returned at run time. The rules that are used to apply column masks in order to derive the new values follow the same rules described above for the final result table of a query. See the data change statements for how the column masks are used to affect the insertability and updatability

A column mask can be applied only to a base table column. If a materialized table expression, materialized view, or common table expression column is involved in the final result table, the above error situations can occur inside the materialized table expression, materialized view, or common table expression definition.

Column access control does not affect the XMLTABLE built-in function. If the input to the XMLTABLE function is a column with a column mask, the column mask is not applied.

Column access control remains activated until the DEACTIVATE COLUMN ACCESS CONTROL clause is used to stop enforcing it.

Row and column access control are not enforced when EXPLAIN tables are populated by Db2

Row and column access control can be enforced for EXPLAIN tables. However, the enabled row permissions and column masks are not applied when Db2 inserts rows into those tables.

Stop enforcing row or column access control

The DEACTIVATE ROW ACCESS CONTROL clause is used to stop enforcing row access control for a table. The default row permission is dropped. Thereafter, when the table is referenced in a data manipulation statement, explicitly created row permissions are not applied. The table is accessible based on the granted privileges.

The DEACTIVATE COLUMN ACCESS CONTROL clause is used to stop enforcing column access control for a table. Thereafter, when the table is referenced in a data manipulation statement, the column masks are not applied. The unmasked column values are used for the final result table.

The explicitly created row permissions or column masks, if any, remain but have no effect.

Secure triggers for row and column access control

Triggers are used for database integrity, and as such a balance between row and column access control (security) and database integrity is needed. Enabled row permissions and column masks are not applied to the initial values of transition variables and transition tables. Row and column access control enforced for the triggering table is also ignored for any transition variables or transition tables referenced in the trigger body. To ensure there is no security concern for SQL statements in the trigger action to access sensitive data in transition variables and transition tables, the trigger must be created or altered with the SECURED option. If a trigger is not secure, row and column access control cannot be enforced for the triggering table.

Secure user-defined functions for row and column access control

If a row permission or column mask definition references a user-defined function, the function must be altered with the SECURED option because the sensitive data might be passed as arguments to the function.

Db2 considers the SECURED option an assertion that declares the user has established a change control audit procedure for all changes to the user-defined function. It is assumed that such a control audit procedure is in place for all versions of the user-defined function, and that all subsequent ALTER FUNCTION statements or changes to external packages are being reviewed by this audit process.

Database operations where row and column access control is not applicable

Row and column access control must not compromise database integrity. Columns involved in primary keys, unique keys, indexes, check constraints, and referential integrity (RI) must not be subject to row and column access control. Column masks can be defined for those columns but they are not applied during the process of key building or constraint or RI enforcement.

Read-only cursors and read-only views

The rules that are used to determine a read-only cursor or a read-only view remain unaffected by row and column access control because those rules are determined at bind time. The effect of application of enabled column masks is not known until run time. Therefore, the data change operation on a writable cursor or a writable view could still fail at run time.

Considerations for adding a column to a system-period temporal table or archive-enabled table

- If the data type of the column is a distinct type:
 - The owner of the history table or archive table must implicitly or explicitly have the USAGE privilege on the distinct type.
 - If the distinct type is unqualified, its schema matches the schema for the following objects:
 - The implicit schema for the distinct type for the column in the history table is the same as the implicit schema that is determined for the distinct type in the system-period temporal table.
 - The implicit schema for the distinct type for the column in the archive table is the same as the implicit schema that is determined for the distinct type in the archive-enabled table.
- The syntax LONG VARCHAR or LONG VARGRAPHIC must not be specified when you add a column to these types of tables. Use VARCHAR or VARGRAPHIC instead.
- If the data type of the column is a LOB and the INLINE LENGTH clause is not specified, Db2 determines the length. The implicit inline length that is used for the column in the system-period temporal table or archive-enabled table is also used for the corresponding column in the history table or archive table.
- If the data type of the column is a LOB, auxiliary objects are implicitly created for it in the system-period temporal table or archive-enabled table. Auxiliary objects are also created for the corresponding column of the history table or archive table.

Effect of renaming a column on statistics profiles

When you execute ALTER TABLE with RENAME COLUMN, statistics profiles that refer to that column are no longer valid. An error occurs when RUNSTATS is run with a profile that contains a renamed column. After you execute ALTER TABLE with RENAME COLUMN, complete these tasks:

1. Delete any statistics profiles that refer to the renamed column.
2. Create the statistics profiles again.

For more information, see:

[RUNSTATS TABLESPACE syntax and options \(Db2 Utilities\)](#)

[Statistics profile syntax \(Db2 Utilities\)](#)

[Deleting statistics profiles \(Db2 Performance\)](#)

[Creating statistics profiles \(Db2 Performance\)](#)

Key label requirement

To use a key label for encryption, the VSAM data sets for the page sets need to be associated with an SMS Data Class that has extended format capability (EF enabled).

Determining a key label for base table space and associated objects

When a key label is specified at the table level, Db2 provides the key label to DFSMS to encrypt all the table spaces and index spaces associated with the table. This includes base table space, auxiliary table spaces, XML table spaces, index spaces, and clone table space, regardless of whether the base table space or associated objects are explicitly or implicitly created. Db2 does not enforce any key label relationship between the base table and an associated history or archive table. The key label for the archive and the history tables has to be set independent of the base table. If there is no key label specified at the table level, Db2 will provide the key label to DFSMS specified for the storage group.

When Db2 calls DFSMS to allocate the dataset for table space or index space, DFSMS uses its order of precedence to determine the key label and can override the key label specified by Db2.

DFSMS order of precedence:

- RACF data set profile
- JCL, dynamic allocation, TSO ALLOCATE
- SMS data class construct

If the security administrator has specified a key label for the RACF data set profile, that key label takes precedence over the Db2 provided key label. The REPORT utility can be run to determine the key label used for encryption.

Description of key label in effect in DB2

Table 185. Example scenarios for a partition-by-growth table space, that describe the key label in effect in DB2. This is the key label provided to DFSMS during allocation of data set for table spaces and index spaces.

Scenarios	Catalog key label value	Key label provided to DFSMS during data set allocation
Create storage group, SG01 with key label, SGKL01.	SYSSTOGROUP record - KEY LABEL: SGKL01	
Create table space, TBSP01 using storage group, SG01 – Creates Partition 1		SGKL01
Create table, TB01 in table space, TBSP01 with key label, TBKL01	SYSTABLESPACE record for TBSP01 / SYSTABLES record for TBKL01 – KEY LABEL: TBKL01	
REORG TABLESPACE TBSP01 – Reorgs Partition 1		TBKL01
Create index, IX01 on table, TB01 creates index space	SYSINDEXES record for IX01 – KEY LABEL: TBKL01	TBKL01

Table 185. Example scenarios for a partition-by-growth table space, that describe the key label in effect in DB2. This is the key label provided to DFSMS during allocation of data set for table spaces and index spaces. (continued)

Scenarios	Catalog key label value	Key label provided to DFSMS during data set allocation
Insert data into TB01 – Creates Partition 2		TBKL01
Alter table, TB01 to specify NO KEY LABEL	SYSTABLESPACE record for TBSP01 / SYSTABLES record for TBKL01 / SYSINDEXES record for IX01 – KEY LABEL: Empty string	
Insert data into TB01 – Creates partition 3		SGKL01
REORG TABLESPACE TBSP01 with REUSE option – Resets and reuses DB2-managed data sets. No change to key label		

Key label considerations

If the last table is dropped from a segmented table space, the table space and its underlying data set will remain. If key label is in effect, the KEYLABEL column for the table space's SYSTABLESPACE record will be cleared. If a new table is created in this table space, it will be encrypted with the previous key label. If the table has to be created as unencrypted, execute the REORG TABLESPACE utility for the table space.

If a table space is explicitly created with the DEFINE YES option and a table with a key label is defined in that table space, then the data sets associated with the table space will not be encrypted. A subsequent REORG is necessary to encrypt the data sets. Users that want immediate encryption of the data sets associated with the table space must to define table spaces with the DEFINE NO option.

Syntax and descriptions for hash organization (deprecated)

Deprecated function: FL 504 Hash-organized tables are deprecated. Beginning in Db2 12, packages bound with APPLCOMPAT(V12R1M504) or higher cannot create hash-organized tables or alter existing tables to use hash-organization. Existing hash organized tables remain supported, but they are likely to be unsupported in the future.

alter-hash-organization

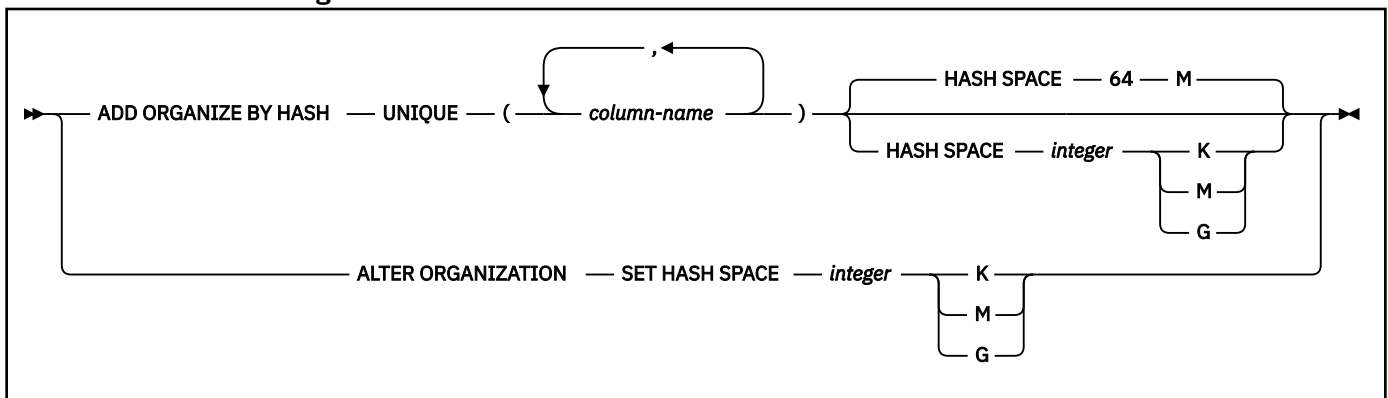

ADD ORGANIZE BY HASH

Specifies that a hash is to be used for the data organization of the table.

ADD ORGANIZE BY HASH must not be specified if the table is already defined with the APPEND YES clause, or if the table space is defined with the MEMBER CLUSTER clause

ALTER TABLE ADD ORGANIZE BY HASH is allowed only if the table is in either a partition-by-growth table space or a partition-by-range table space.

ALTER TABLE ADD ORGANIZE BY HASH is not allowed for table spaces with relative numbering.

ADD ORGANIZE BY HASH must not be specified on tables that are using basic row format.

ADD ORGANIZE BY HASH must not be specified if a user specified clustering index exists.

ADD ORGANIZE BY HASH must not be specified for global temporary tables.

After ALTER TABLE with ADD ORGANIZE BY HASH runs:

- All columns that are part of the hash key are no longer updatable. SQL statements that update a column of the hash key return an error.
- The entire table space that contains the table must be reorganized.

Use of this clause or keyword might invalidate packages that depend on the target object, or packages that depend on related objects through cascading effects. See [Changes that invalidate packages \(Db2 Application programming and SQL\)](#).

UNIQUE

Specifies that Db2 enforces uniqueness of the hash key columns, preventing the table from containing two or more rows with the same value of the hash key.

(*column-name*, ...)

The list of column names defines the hash key that is used to determine where a row will be placed.

Each *column-name* must be an unqualified name that identifies a column of the table. The same column must not be specified more than one time and the specified columns must be defined as NOT NULL. The number of specified columns must not exceed 64, and the sum of their length attributes must not exceed 255. A specified column cannot be any of the following types of columns:

- a LOB column
- a DECFLOAT column
- an XML column
- a distinct type column that is based on one of the preceding data types

All character and graphic string columns in the key must use the same encoding scheme.

If the table is defined as partition by range, the list of column names must specify all of the column names that are specified in the *partition-expression* for the table, and must specify the column names in the same order as *partition-expression*. If the ORGANIZE BY clause contains more columns than the *partition-expression* for the table, *partition-expression* determines the partition number.

HASH SPACE *integer*K|M|G

Specifies the amount of fixed hash space to preallocate for the table. If the table is partition-by-range, this is the space for each partition.

The default is 64M for a table in a partition-by-growth table space or 64M for each partition of a partition-by-range table space.

K

Indicates that the *integer* value is multiplied by 1024 to specify the hash space size in bytes. The *integer* value must be in the range 256–268,435,456.

M

Indicates that the *integer* value is multiplied by 1,048,576 to specify the hash space size in bytes. The *integer* value must be in the range 1–262,144.

G

Indicates that the *integer* value is to be multiplied by 1,073,741,824 to specify the hash space size in bytes. The *integer* value must be in the range 1–256 for a partition by range table and must be in the range 1–131,072 for a non-partitioned table.

If a value greater than 4G is specified, the data sets for the table space are associated with a DFSMS data class that has been specified with extended format and extended addressability.

ALTER ORGANIZATION SET HASH SPACE *integer*

Changes the fixed hash space that is used for the data organization for the table. The table must be defined to use hash organization.

If the table is defined as partition-by-range, the value specified by *integer* is per partition and applies to each partition of the table. For tables that are not partition-by-range, *integer* applies to the whole table.

The new hash space value will be applied when the table space is reorganized using the REORG utility.

HASH SPACE *integer*K|M|G

Specifies the amount of fixed hash space to preallocate for the table. If the table is partition-by-range, this is the space for each partition.

K

Indicates that the *integer* value is multiplied by 1024 to specify the hash space size in bytes. The *integer* value must be in the range 256–268,435,456.

M

Indicates that the *integer* value is multiplied by 1,048,576 to specify the hash space size in bytes. The *integer* value must be in the range 1–262,144.

G

Indicates that the *integer* value is to be multiplied by 1,073,741,824 to specify the hash space size in bytes. The *integer* value must be in the range 1–256 for a partition by range table and must be in the range 1–131,072 for a non-partitioned table.

If a value greater than 4G is specified, the data sets for the table space are associated with a DFSMS data class that has been specified with extended format and extended addressability.

Be aware that specifying the ALTER ORGANIZATION clause might affect subsequent requests to recover to a point in time. For information about possible restrictions, effects on recovery status, and other considerations, see [Point-in-time recovery \(Db2 Utilities\)](#).

DROP ORGANIZATION

See “DROP ORGANIZATION” on page 1283.

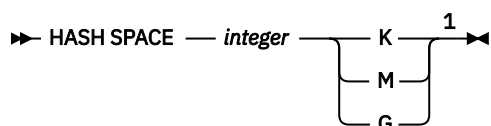
partition-hash-space

Notes:

¹ The HASH SPACE clause can only be specified for the ALTER PARTITION clause.

HASH SPACE *integer*K|M|G

Specifies the amount of fixed hash space to preallocate for the partition that is associated with the partition element. If HASH SPACE is omitted from the partition element, the HASH SPACE value that is specified in the ORGANIZE BY CLAUSE is used.

The HASH SPACE keyword in the *partition-element* must only be specified if the table is defined to use hash organization.

K

Indicates that the *integer* value is multiplied by 1024 to specify the hash space size in bytes. The *integer* value must be in the range 256–268,435,456.

M

Indicates that the *integer* value is multiplied by 1,048,576 to specify the hash space size in bytes. The *integer* value must be in the range 1–262,144.

G

Indicates that the *integer* value is to be multiplied by 1,073,741,824 to specify the hash space size in bytes. The *integer* value must be in the range 1–256 for a partition by range table and must be in the range 1–131,072 for a non-partitioned table.

If a value greater than 4G is specified, the data sets for the table space are associated with a DFSMS data class that has been specified with extended format and extended addressability.

Notes for hash organization (deprecated)

Deprecated function: FL 504 Hash-organized tables are deprecated. Beginning in Db2 12, packages bound with APPLCOMPAT(V12R1M504) or higher cannot create hash-organized tables or alter existing tables to use hash-organization. Existing hash organized tables remain supported, but they are likely to be unsupported in the future.

When changes to the hash organization of a table take place

An alter of the table that uses hash organization will take effect immediately in terms of enforcing the unique hash key. However, the physical organization of the table space is converted to hash organization after REORG.

In a partition-by-range table space, if individual partitions are altered to specify HASH SPACE, the new hash space values take effect after the REORG utility is run on the individual partitions.

Buffer pool, DSSIZE, and MAXPARTITIONS considerations for tables using hash organization

Db2 calculates an optimum buffer pool size for hash organization based on the definition of the table and validate the calculated buffer pool size with the buffer pool of the explicitly created table space. If the buffer pool sizes are different, Db2 returns an error.

If the table is a partition-by-range table space, the DSSIZE value for the table space must be large enough to fit the HASH SPACE specification for each partition.

If the table is in a partition-by-growth table space, the total space calculated from the DSSIZE and MAXPARTITIONS values for the table space must be large enough for the implicitly or explicitly specified HASH SPACE.

Changing the hash space value

To change the HASH SPACE value for all partitions of a partition-by-range table space or to change the total HASH SPACE for a partition-by-growth table space, use the ALTER ORGANIZATION SET HASH SPACE (*integer*) clause. To change HASH SPACE value for more than one, but not all partitions of a partition-by-range table space you must specify separate ALTER TABLE statements for each partition and specify the ALTER PARTITION (*integer*) and HASH SPACE (*integer*) clauses.

Hash space and Db2 page size

If the specified hash space is less than or equal to 64 MB (the Db2 default), Db2 will add extra space for Db2 system pages. If the specified hash space is greater than 64 MB, Db2 will use part of the hash space for Db2 system pages. The amount of space needed for Db2 system pages depends on SEGSIZE and PAGESIZE. The larger the SEGSIZE and/or PAGESIZE becomes, the larger the requirement for Db2 system pages. Db2 can reserve up to 5 MB for system pages for the highest SEGSIZE value (64) and PAGESIZE value (32K).

Hash space and DSSIZE

Depending on certain table space characteristics, Db2 needs to reserve space for the hash overflow area. Therefore, the amount of hash space cannot be equal to the DSSIZE value. The maximum amount of hash space that can be specified is approximately 20% less than the DSSIZE

value. Db2 returns an error if the amount of hash space is too large. If the amount of hash space is too large, specify a larger value of DSSIZE, or decrease the amount of hash space.

Specifying APPEND for hash-organized tables

Append processing is not applicable to tables with hash organization since there is no key clustering in hash organization. For insert operations into tables with hash organization, Db2 will use the internal hash algorithm to determine the location of the row.

Restrictions for tables with hash organization

Tables that use hash organization are subject to the following restrictions:

- If the table already uses hash organization, Db2 will return an error.
- A table that is defined to use hash organization cannot be created in a LOB table space or XML table space.
- The data type of columns that are specified in a hash key cannot be changed.
- Partition level REORG is not allowed after the table is changed using the ALTER ADD HASH ORGANIZATION clause or the ALTER DROP ORGANIZATION clause.
- The MAXROWS clause is applicable only to the hash overflow area of the table space for tables with hash organization. The fixed hash area of each page will contain as many rows as it can hold, up to a maximum of 255.

Alternative syntax and synonyms

To provide compatibility with previous releases of Db2 or other products in the Db2 family, Db2 supports the following clauses:

- NOCACHE (single clause) as a synonym for NO CACHE
- NOCYCLE (single clause) as a synonym for NO CYCLE
- NOMINVALUE (single clause) as a synonym for NO MINVALUE
- NOMAXVALUE (single clause) as a synonym for NO MAXVALUE
- NOORDER (single clause) as a synonym for NO ORDER
- PART *integer* VALUES can be specified as an alternative to PARTITION *integer* ENDING AT.
- VALUES as a synonym for ENDING AT
- DEFINITION ONLY as a synonym for WITH NO DATA
- SET MATERIALIZED QUERY AS DEFINITION ONLY as a synonym for DROP MATERIALIZED QUERY
- SET SUMMARY AS DEFINITION ONLY as a synonym for DROP MATERIALIZED QUERY
- SET MATERIALIZED QUERY AS (fullselect) as a synonym for ADD MATERIALIZED QUERY (fullselect)
- SET SUMMARY AS (fullselect) as a synonym for ADD MATERIALIZED QUERY (fullselect)
- TIMEZONE can be specified as an alternative to TIME ZONE.

Examples for ALTER TABLE

Example 1

Column DEPTNAME in table DSN8C10.DEPT was created as a VARCHAR(36). Increase its length to 50 bytes. Also, add the column BLDG to the table DSN8C10.DEPT. Describe the new column as a character string column that holds SBCS data.

```
ALTER TABLE DSN8C10.DEPT
  ALTER COLUMN DEPTNAME SET DATA TYPE VARCHAR(50)
  ADD BLDG CHAR(3) FOR SBCS DATA;
```

Example 2

Assign a validation procedure named DSN8EAEM to the table DSN8C10.EMP.

```
ALTER TABLE DSN8C10.EMP
  VALIDPROC DSN8EAEM;
```

Example 3

Disassociate the current validation procedure from the table DSN8C10.EMP. After the statement is executed, the table no longer has a validation procedure.

```
ALTER TABLE DSN8C10.EMP
VALIDPROC NULL;
```

Example 4

Define ADMRDEPT as the foreign key of a self-referencing constraint on DSN8C10.DEPT.

```
ALTER TABLE DSN8C10.DEPT
FOREIGN KEY (ADMRDEPT) REFERENCES DSN8C10.DEPT ON DELETE CASCADE;
```

Example 5

Add a check constraint to the table DSN8C10.EMP which checks that the minimum salary an employee can have is \$10,000.

```
ALTER TABLE DSN8C10.EMP
ADD CHECK (SALARY >= 10000);
```

Example 6

Alter the PRODINFO table to define a foreign key that references a non-primary unique key in the product version table (PRODVER_1). The columns of the unique key are VERNAME, RELNO.

```
ALTER TABLE PRODINFO
FOREIGN KEY (PRODNAME,PRODVERNO)
REFERENCES PRODVER_1 (VERNAME,RELNO) ON DELETE RESTRICT;
```

Example 7

Assume that table DEPT has a unique index defined on column DEPTNAME. Add a unique key constraint named KEY_DEPTNAME consisting of column DEPTNAME to the DEPT table:

```
ALTER TABLE DSN8C10.DEPT
ADD CONSTRAINT KEY_DEPTNAME UNIQUE( DEPTNAME );
```

Example 8

Register the base table TRANSCOUNT as a materialized query table. The result of the fullselect must provide a set of columns that match the columns in the existing table (same number of columns, same column definitions, and same names). So that you can maintain the table with insert, update, and delete operations as well as the REFRESH TABLE statement, define the materialized query table as user-maintained.

```
ALTER TABLE TRANSCOUNT ADD MATERIALIZED QUERY
(SELECT ACCTID, LOCID, YEAR, COUNT(*) as cnt
FROM TRANSadd
GROUP BY ACCTID, LOCID, YEAR )
DATA INITIALLY DEFERRED
REFRESH DEFERRED
MAINTAINED BY USER;
```

Example 9

Assume that table TB1 has a column, COL1 that is defined as CHAR(4) FOR BIT DATA WITH DEFAULT 'AB'. The value that is stored in the table will be X'C1C24040'. After the following ALTER TABLE statement is run, the resulting value that is stored in the table will be BX'C1C240400000':

```
ALTER TABLE TB1
ALTER COLUMN COL1
SET DATA TYPE BINARY(6);
```

Example 10

Add a key label to the table space, DSN8C10.EMP to encrypt all the table spaces and index spaces associated with the table.

```
ALTER TABLE DSN8C10.EMP
KEY LABEL SECUREKEY01;
```

Examples for column access controls

Example 1

Based on the data in the CUSTOMER table, the SELECT DISTINCT statement returns one row with the SALARY value 100,000. A column mask, SALARY_MASK, is created to mask the salary value. After column access control is activated for the CUSTOMER table, the column mask is applied to SALARY column. A user with the 'MGR' ID (or role) issues a SELECT DISTINCT statement. The SELECT DISTINCT statement still returns one row because the removal of duplicates is based on the unmasked value of the SALARY column, but the value that is returned in that row is based on the masked SALARY value, which can be either 125,000 or 110,000.

The table CUSTOMER contains:

SALARY	COMMISSION	EMPID
100,000	25,000	123456
100,000	10,000	654321

```
CREATE MASK SALARY_MASK ON CUSTOMER
  FOR COLUMN SALARY RETURN
    CASE WHEN (SESSION_USER = 'MGR')
      THEN SALARY + COMMISSION
    ELSE SALARY
  END
ENABLE;

COMMIT;

ALTER TABLE CUSTOMER
  ACTIVATE COLUMN ACCESS CONTROL;

COMMIT;

SELECT DISTINCT SALARY FROM CUSTOMER;
```

Example 2

Based on the data in T1 and T2 tables, the SELECT DISTINCT statement using the COALESCE function returns one row with the T1.C1 value of 1. A column mask, C1_MASK, is created to mask the value of T1.C1. After column access control is activated for table T1, the column mask is applied to column C1 of table T1. A user with the 'EMP' ID (or role) issues a SELECT DISTINCT statement. The SELECT DISTINCT statement still returns one row because the removal of duplicates is based on the unmasked value of T1.C1 from the COALESCE function, but the value that is returned in that row is based on the masked value of T1.C1 from the COALESCE function. The returned value can be either 2 or 3.

```
INSERT INTO T1(C1) VALUES(1);
INSERT INTO T1(C1) VALUES(1);
INSERT INTO T2(C1) VALUES(2);
INSERT INTO T2(C1) VALUES(3);

CREATE MASK C1_MASK ON T1
  FOR COLUMN C1 RETURN
    CASE WHEN (SESSION_USER = 'EMP')
      THEN NULL
    ELSE C1
  END
ENABLE;

COMMIT;

ALTER TABLE T1
  ACTIVATE COLUMN ACCESS CONTROL;

COMMIT;

SELECT DISTINCT COALESCE(T1.C1, T2.C1) FROM T1, T2;
```

Example 3

Based on the data in the CUSTOMER table, the maximum income is the same in the states CA and IL, 50,000, thus, the SELECT DISTINCT statement returns one row. A column mask, INCOME_MASK, is created to mask the income value. After column access control is activated for the CUSTOMER table, the column mask is applied to the INCOME column before the MAX aggregate function is evaluated. However, the INCOME_MASK column mask, masks the income value of 0 as 100,000 in state IL. As a result, the maximum income becomes 100,000 for state IL, but the maximum income is still 50,000 for state CA. X.B is used in a predicate in the SELECT DISTINCT statement, therefore, the original INCOME values and the original results of the MAX(INCOME) function must be preserved. So the SELECT DISTINCT statement still returns one row, but the value in that row might not be deterministic, that is, the value might be 50,000 from the 'CA' row or might be 100,000 from the 'IL' row.

The CUSTOMER table contains:

STATE	INCOME
CA	40,000
CA	50,000
IL	0
IL	10,000
IL	50,000

```
CREATE MASK INCOME_MASK ON CUSTOMER
FOR COLUMN INCOME RETURN
    CASE WHEN(INCOME = 0)
        THEN 100000
        ELSE INCOME
    END
ENABLE;

COMMIT;

ALTER TABLE CUSTOMER
ACTIVATE COLUMN ACCESS CONTROL;

COMMIT;

SELECT DISTINCT B FROM
(SELECT STATE, MAX(INCOME) FROM CUSTOMER
GROUP BY STATE)
X(A, B)
WHERE B > 10000;
```

Example 4

The expression INCOME + RAND() is not deterministic because the RAND function is not deterministic. Based on the data in the CUSTOMER table, the SELECT DISTINCT statement will, most likely, return two distinct rows. However, it could return only one row. A column mask, INCOME_MASK, is created to mask the income value. After column access control is activated for the CUSTOMER table, the column mask is applied to the INCOME column, which causes the masked value for both rows to be the same. Because the RAND function is not deterministic, the SELECT DISTINCT statement will, most likely, still return two distinct rows, but it could return only one row. The uncertainty caused by the RAND function causes the result of the SELECT DISTINCT statement to not be deterministic.

The CUSTOMER table contains:

STATE	INCOME
CA	40,000

STATE	INCOME
CA	50,000

```

CREATE MASK INCOME_MASK ON CUSTOMER
  FOR COLUMN INCOME RETURN
    CASE WHEN(INCOME = 40,000)
      THEN 50000
    ELSE INCOME
  END
  ENABLE;

COMMIT;

ALTER TABLE CUSTOMER
  ACTIVATE COLUMN ACCESS CONTROL;

COMMIT;

SELECT DISTINCT A FROM
  (SELECT INCOME + RAND() FROM CUSTOMER)
  X(A)
  WHERE A > 10000;

```

Example 5

A column mask, STATE_MASK, is created for the STATE column of the CUSTOMER table to return a value that shows the city name with the state if the city is SJ, SFO, or OKLD. Otherwise the city is not returned, just the state. After column access control is activated for the CUSTOMER table, a SELECT statement which groups results using the STATE column is issued. However, because the CITY column that is referenced in the STATE_MASK column mask is not a grouping column, a bind time error is returned to signify that the STATE_MASK column mask is not appropriate for this statement.

The CUSTOMER table contains:

STATE	CITY	INCOME
CA	SJ	40,000
CA	SC	30,000
CA	SB	60,000
CA	SFO	80,000
CA	OKLD	50,000
CA	SJ	70,000
NY	NY	50,000

```

CREATE MASK STATE_MASK ON CUSTOMER
  FOR COLUMN STATE RETURN
    CASE WHEN(CITY = 'SJ')
      THEN CITY||', '||STATE
    WHEN(CITY = 'SFO')
      THEN CITY||', '||STATE
    WHEN(CITY = 'OKLD')
      THEN CITY||', '||STATE
    ELSE ' , '||STATE
  END
  ENABLE;

COMMIT;

ALTER TABLE CUSTOMER
  ACTIVATE COLUMN ACCESS CONTROL;

COMMIT;

SELECT STATE, AVG(INCOME) FROM CUSTOMER

```

```
GROUP BY STATE  
HAVING STATE = 'CA';
```

Related concepts

Unicode columns in EBCDIC tables

A single encoding scheme is used for all character and character string data in a table. An exception is that an EBCDIC table can contain one or more Unicode columns in addition to EBCDIC string columns.

ALTER TABLESPACE statement

The ALTER TABLESPACE statement changes the description of a table space at the current server.

Invocation for ALTER TABLESPACE

This statement can be embedded in an application program or issued interactively. It is an executable statement that can be dynamically prepared only if DYNAMICRULES RUN behavior is in effect. For more information, see [“Authorization IDs and dynamic SQL”](#) on page 94.

Authorization for ALTER TABLESPACE

The privilege set that is defined below must include at least one of the following:

- Ownership of the table space
- DBADM authority for its database
- SYSADM or SYSCTRL authority
- System DBADM
- Installation SYSOPR authority (when the current SQLID of the process is set to SYSINSTL)

If the database is implicitly created, the database privileges must be on the implicit database or on DSNDB04.

If BUFFERPOOL or USING STOGROUP is specified, additional privileges might be required, as explained in the description of those clauses.

Privilege set: If the statement is embedded in an application program, the privilege set is the privileges that are held by the owner of the package. If the statement is dynamically prepared, the privilege set is the union of the privilege sets that are held by each authorization ID and role of the process.

→ ALTER TABLESPACE *database-name . table-space-name* →

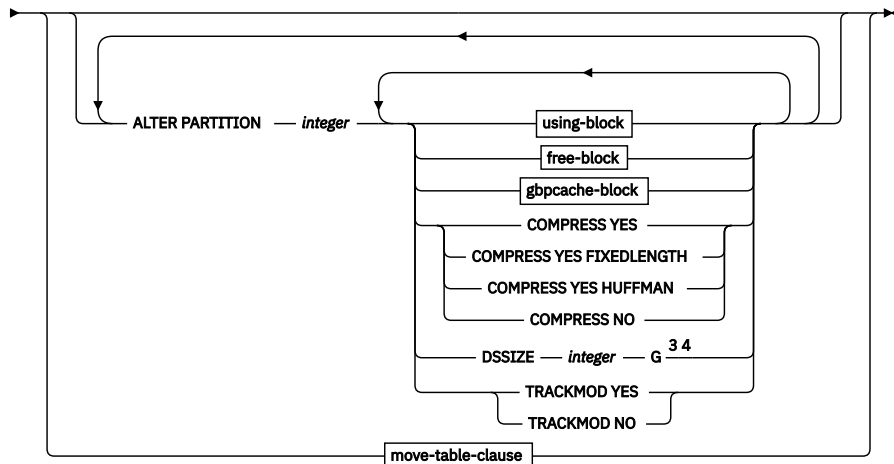
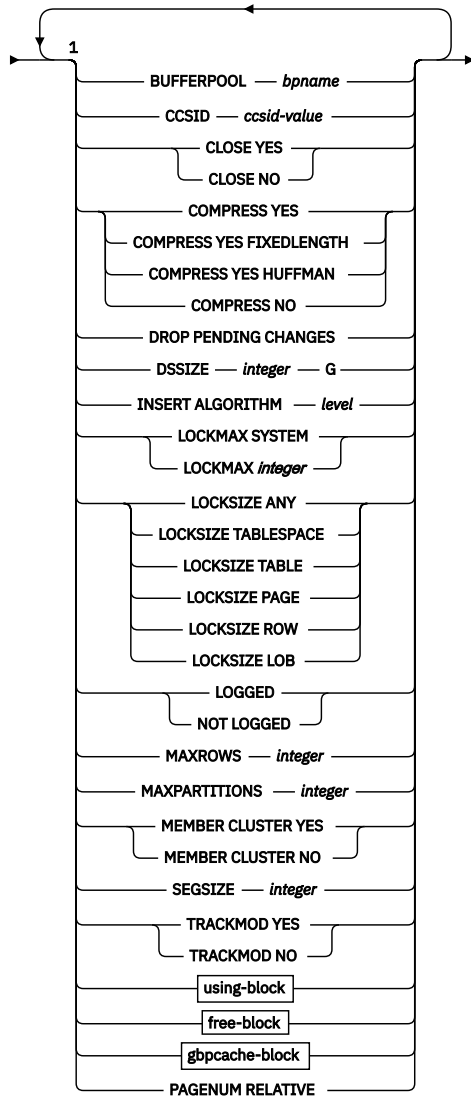

Notes:

¹ FL 508 If you specify DROP PENDING CHANGES, DSSIZE, SEGSIZE, PAGENUM, or MOVE TABLE, no other clauses can be specified in the same ALTER TABLESPACE statement.

- ² The same clause must not be specified more than one time in a single ALTER TABLESPACE statement.
- ³ DSSIZE can be specified at the partition level only for a table space with relative page numbering (PAGENUM RELATIVE).
- ⁴ The specified DSSIZE value must be greater than or equal to the current DSSIZE value for the partition.

using-block:

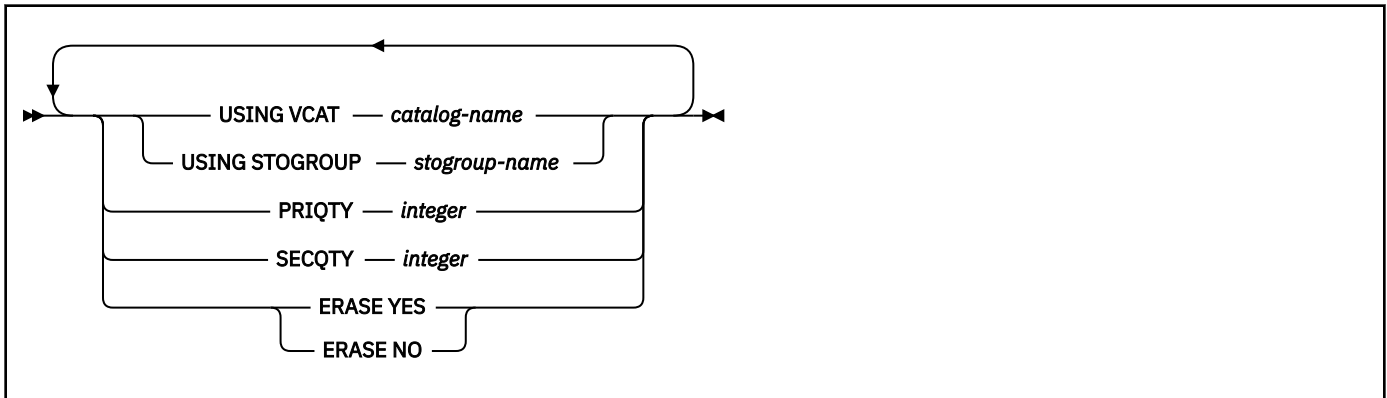

free-block:

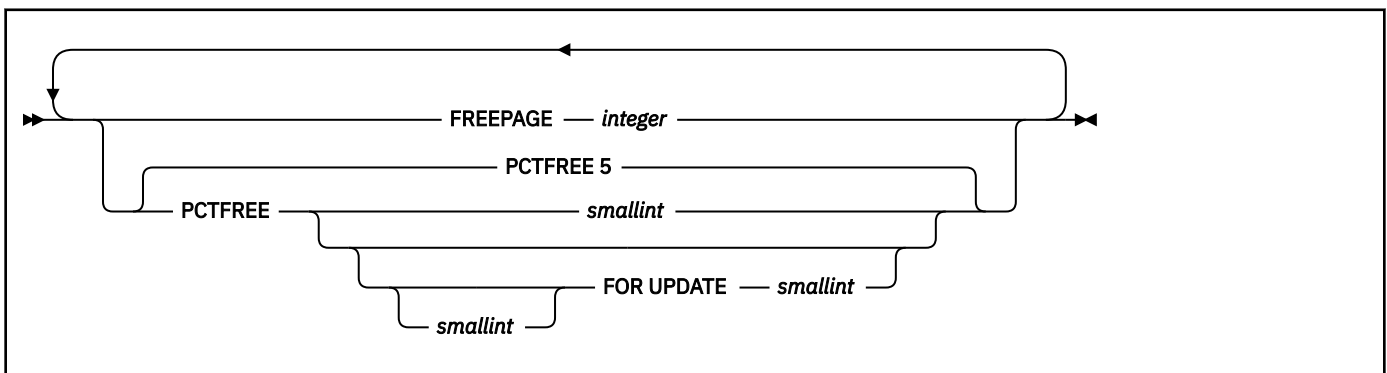

gbpcache-block:



move-table-clause:

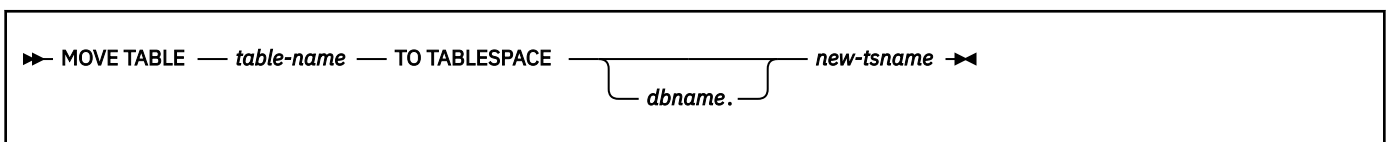

Description for ALTER TABLESPACE

database-name.table-space-name

Identifies the table space that is to be altered. The name must identify a table space that exists at the current server. Omission of *database-name* is an implicit specification of DSNDB04.

If you identify a partitioned table space, you can use the ALTER PARTITION clause.

A table space cannot be altered if it is associated with an accelerator-only table or a directory table.

BUFFERPOOL *bpname*

Identifies the buffer pool that is to be used for the table space. *bpname* must identify an activated buffer pool.

The privilege set must include SYSADM or SYSCTRL authority or the USE privilege for the buffer pool.

If *bpname* specifies a buffer pool with a smaller page size than the current page size, the maximum record size of all tables in the table space must fit in the smaller page size.

If *bpname* specifies a buffer pool with a different page size, the table space must be one of the following types:

- A universal table space (excluding XML table spaces)
- A table space for which a pending definition change will convert the table space to a universal table space
- A LOB table space

If the table space is a partition-by-growth table space, the page size must be valid depending on the values that are in effect for the MAXPARTITIONS and DSSIZE options of the table space. If the table space is a partition-by-range table space, the page size must be valid depending on the values that are in effect for the current number of partitions and the DSSIZE option of the table space. For more information about the relationship between DSSIZE, MAXPARTITIONS, buffer pool page size and table space size, see [“Maximum number of partitions and table space size” on page 1340](#).

Depending on the situation when this clause is specified, Db2 might process the ALTER statement as a *pending data definition change*, which means the current object definition and data do not reflect the alteration at the time that the statement is issued. Instead, the altered object is placed in an advisory REORG-pending (AREOR) state, and a subsequent reorganization of the altered object with an appropriate utility materializes the changes to the catalog and data. For more information, see [Pending data definition changes \(Db2 Administration Guide\)](#).

When pending definition changes are specified for the BUFFERPOOL, DSSIZE, MAXPARTITIONS, or SEGSIZE attributes of partition-by-growth (PBG) table spaces, the number of partitions is determined based on the amount of existing data at the time the pending change is applied, and partition growth can occur. If LOB columns exist, additional LOB table spaces and auxiliary objects are implicitly created for the newly-created partitions independent of whether SQLRULES (DB2) or SQLRULES (STD) is in effect or whether the table space was explicitly or implicitly created. The new LOB objects inherit the buffer pool attribute and authorization from the existing LOB objects.

For an immediate change for which the page size of both buffer pools is the same, the table space and all data sets are immediately available. The data sets do not need to be closed and reopened for the table space to be available. In addition, Db2 automatically closes required data sets. The description of the table space takes effect the next time the data sets of the table space are opened.

CCSID *ccsid-value*

Identifies the CCSID value to be used for the table space. *ccsid-value* must identify a CCSID value that is compatible with the current value of the CCSID for the table space. See [“ALTER DATABASE statement” on page 1095](#) for a list that shows the CCSID to which a given CCSID can be changed and details about changing it.

Do not specify CCSID for a LOB table space, a table space that is implicitly created for an XML column, or a table space in a work file database.

The CCSID of a table space cannot be changed if any of the following conditions are true:

- The table space contains any table that has an index that contains expressions.
- The table space contains a system-period temporal table or a history table.
- The table space contains an archive-enabled table or an archive table.

CLOSE

When the limit on the number of open data sets is reached, specifies the priority in which data sets are closed.

YES

Eligible for closing before CLOSE NO data sets. This is the default unless the table space is in a work file database.

NO

Eligible for closing after all eligible CLOSE YES data sets are closed.

For a table space in a work file database, Db2 uses CLOSE NO regardless of the value specified

COMPRESS

Specifies whether data compression applies to the rows of the table space or a partition in the table space.

Do not specify COMPRESS for a table space in a work file database.

YES

FL 509 Specifies that data compression is used for the table space or partition. The rows are not compressed until the LOAD or REORG utility is run on a table in the table space or partition, or until the total row data size reaches the compression data threshold while an insert operation is performed.

If a keyword for the compression algorithm is not specified, the default compression algorithm is used:

- The data compression algorithm is determined by the TS_COMPRESSION_TYPE subsystem parameter.
 - If the table space is a LOB table space, the following requirements must also be met:
 - Db2 12 must be at function level 500 or higher.
 - The zEDC hardware and software must be available and configured in the z/OS system. For more information, see [Requirements for zEnterprise Data Compression](#).
- In data sharing, system performance can degrade dramatically if a member accesses compressed LOB data and the zEDC hardware and software are not configured in z/OS.
- The LOB table space must be associated with a base table that is in a universal table space.
 - The total length of the entire LOB must be larger than the defined data page size, otherwise the LOB is not compressed.

FIXEDLENGTH

FL 509 Specifies the fixed-length data compression algorithm.

FIXEDLENGTH must not be specified for LOB table spaces. Any LOB table spaces that are implicitly created for LOB columns in this table space are defined as if COMPRESS YES had been specified without a compression algorithm. LOB compression is managed by zEnterprise® data compression (zEDC) hardware, which must be available on the z/OS system.

HUFFMAN

FL 509 Specifies the Huffman data compression algorithm. See [Using Huffman compression to compress your data \(Db2 Performance\)](#) for requirements to enable Huffman compression.

HUFFMAN must be specified only for universal table spaces and must not be specified for table spaces that contain tables defined with ORGANIZE BY HASH.

HUFFMAN must not be specified for LOB table spaces. Any LOB table spaces that are implicitly created for LOB columns in this table space are defined as if COMPRESS YES had been specified without a compression algorithm. LOB compression is managed by zEnterprise data compression (zEDC) hardware, which must be available on the z/OS system.

NO

Specifies no data compression. Inserted rows are not compressed. Updated rows are decompressed. The dictionary used for data compression is erased when the LOAD REPLACE,

LOAD RESUME NO, or REORG utility is run. For more information about the dictionary and data compression, see [Compressing your data \(Db2 Performance\)](#).

DROP PENDING CHANGES

Drops pending changes to the definition of the table space and any objects within the table space. Pending changes to the definition of the table space or any object within the table space must exist.

When the DROP PENDING CHANGES clause is specified, no other options are allowed in the same ALTER TABLESPACE statement.

The DROP PENDING CHANGES clause also resets advisory REORG-pending (AREOR) status except for tables that are converting to hash access.

DSSIZE *integer* G

Specifies the maximum data set size in gigabytes. DSSIZE can be specified only for these types of table spaces:

- A partition-by-growth or partition-by-range table space
- A table space for which a pending definition change will convert the table space to a universal table space
- A LOB table space

Therefore, the DSSIZE value specifies the maximum size of a partition of a universal table space or the maximum size of any data set in a LOB table space. When DSSIZE is specified, no other options are allowed in the same ALTER TABLESPACE statement.

To specify a value greater than 4G, the data sets for the table space must be associated with a DFSMS data class that has been specified with extended format and extended addressability.

DSSIZE that is specified at the table space level is applied to each of the partitions of the table space.

integer can be separated from G by 0 or more spaces.

The accepted values that you can specify depend on the type of table space.

Partition-by-growth

Specify a power-of-two value in the range 1–256 G.

Partition-by-range with relative page numbers

Specify any value 1–1024 G. The following values determine the DSSIZE value for each partition, in the order of precedence shown:

1. The DSSIZE value in the PARTITION clause for that partition.
2. The DSSIZE value specified at the table space level, not inside a PARTITION clause.
3. The default value 4G.

Partition-by-range with absolute page numbers

Specify a power-of-two value 1–256 G.

Depending on the situation when this clause is specified, Db2 might process the ALTER statement as a *pending data definition change*, which means the current object definition and data do not reflect the alteration at the time that the statement is issued. Instead, the altered object is placed in an advisory REORG-pending (AREOR) state, and a subsequent reorganization of the altered object with an appropriate utility materializes the changes to the catalog and data. For more information, see [Pending data definition changes \(Db2 Administration Guide\)](#).

When pending definition changes are specified for the BUFFERPOOL, DSSIZE, MAXPARTITIONS, or SEGSIZE attributes of partition-by-growth (PBG) table spaces, the number of partitions is determined based on the amount of existing data at the time the pending change is applied, and partition growth can occur. If LOB columns exist, additional LOB table spaces and auxiliary objects are implicitly created for the newly-created partitions independent of whether SQLRULES (DB2) or SQLRULES (STD) is in effect or whether the table space was explicitly or implicitly created. The new LOB objects inherit the buffer pool attribute and authorization from the existing LOB objects.

INSERT ALGORITHM *level*

Specifies the algorithm that is used when rows are inserted into tables in this table space. The insert algorithm level is used only where applicable (MEMBER CLUSTER UTS). Altering the insert algorithm for a table space occurs immediately.

1

Specifies the basic insert algorithm is used.

2

Specifies that insert algorithm 2 is used.

Important: The insert algorithm level can be changed only to level 1 or 2. Level 0, which is supported by CREATE TABLESPACE, is not supported by ALTER TABLESPACE.

LOCKMAX

Specifies the maximum number of page, row, or LOB locks an application process can hold simultaneously in the table space. If a program requests more than that number, locks are escalated. The page, row, or LOB locks are released and the intent lock on the table space or segmented (non-UTS) table is promoted to S or X mode. If you specify LOCKMAX a for table space in a work file database, Db2 ignores the value because these types of locks are not used.

integer

Specifies the number of locks allowed before escalating, in the range 0–2147483647.

Zero (0) indicates that the number of locks on the table or table space are not counted and escalation does not occur.

SYSTEM

FL 507 Specifies that Db2 determines the maximum number of locks that a program can hold simultaneously in the table space from the SYSIBMADM.MAX_LOCKS_PER_TABLESPACE built-in global variable.

For related information see [SYSIBMADM.MAX_LOCKS_PER_TABLESPACE](#).

If you change LOCKSIZE and omit LOCKMAX, the following results occur:

LOCKSIZE	Resultant LOCKMAX
TABLESPACE or TABLE	0
PAGE, ROW, or LOB	Unchanged
ANY	SYSTEM

If the lock size is TABLESPACE or TABLE, LOCKMAX must be omitted, or its operand must be 0.

LOCKSIZE

Specifies the size of locks used within the table space and, in some cases, also the threshold at which lock escalation occurs. Do not specify LOCKSIZE for a table space in a work file database.

ANY

Specifies that Db2 can use any lock size.

In most cases, Db2 uses LOCKSIZE PAGE LOCKMAX SYSTEM for non-LOB table spaces and LOCKSIZE LOB LOCKMAX SYSTEM for LOB table spaces. However, when the number of locks acquired for the table space exceeds the maximum number of locks allowed for a table space (an installation parameter), the page or LOB locks are released and locking is set at the next higher level. If the table space is segmented, the next higher level is the table. If the table space is not segmented, the next higher level is the table space.

TABLESPACE

Specifies table space locks.

TABLE

Specifies table locks. Use TABLE only for a segmented (non-UTS) table space. Do not use TABLE for a universal table space.

PAGE

Specifies page locks. Do not use PAGE for a LOB table space.

ROW

Specifies row locks. Do not use ROW for a LOB table space.

LOB

Specifies LOB locks. Use LOB only for a LOB table space.

The LOCKSIZE change affects a dynamic SQL statement if the statement is prepared and executed after the change. The LOCKSIZE change affects a static SQL statement if the statement is executed after the change.

LOGGED or NOT LOGGED

Specifies whether changes that are made to the data in the specified table space are recorded in the log.

LOGGED

Specifies that changes that are made to the data in the specified table space are recorded in the log. This applies to all tables in the specified table space and to all indexes of those tables. Table spaces and indexes that are created for XML columns inherit the logging attribute from the associated base table space. Auxiliary indexes inherit the logging attribute from the associated base table space. This can affect the logging attribute of associated LOB table spaces. For more information, see [“Altering the logging attribute of a table space” on page 1337](#).

If the base table space is in informational copy-pending status (meaning updates have been made to the table space) when you change from NOT LOGGED to LOGGED, the base table space is placed in copy-pending status. All indexes of tables in the table space are unchanged from their current state; that is, if an index is currently in informational copy-pending status, it will remain in information copy-pending status.

Specifying LOGGED for a LOB table space requires that the base table space also specifies the LOGGED parameter.

LOGGED cannot be specified for XML table spaces. The logging attribute of an XML table space is inherited from its base table space.

LOGGED cannot be specified for table spaces in DSNDB06 (the Db2 catalog) or in a work file database.

NOT LOGGED

Specifies that changes that are made to data in the specified table space are not recorded in the log. This applies to all tables in the specified table space and to all indexes of those tables. Table spaces and indexes that are created for XML columns inherit the logging attribute from the associated base table space. Auxiliary indexes inherit the logging attribute from the associated base table space. This parameter can affect the logging attribute of associated LOB table spaces. For more information, see [“Altering the logging attribute of a table space” on page 1337](#).

NOT LOGGED prevents undo and redo information from being recorded in the log for the base table space; however, control information for the specified base table space will continue to be recorded in the log. For a LOB table space, changes to system pages and to auxiliary indexes are logged.

NOT LOGGED is mutually exclusive with the DATA CAPTURE CHANGES parameter of CREATE TABLE and ALTER TABLE. NOT LOGGED will not be applied to the table space if any table in the table space specifies DATA CAPTURE CHANGES.

NOT LOGGED cannot be specified for XML table spaces.

NOT LOGGED cannot be specified for table spaces in the following databases:

- DSNDB06 (the Db2 catalog)
- a work file database

MAXROWS *integer*

Specifies the maximum number of rows that Db2 will consider placing on each data page. The integer can range from 1 through 255.

The change takes effect immediately for new rows added. However, the space class settings for some pages might be incorrect and could cause unproductive page visits. It is highly recommended to reorganize the table space after altering MAXROWS.

After ALTER TABLESPACE with MAXROWS is run, the table space is placed into an advisory REORG-pending status. Run the REORG TABLESPACE utility to remove the status.

Do not specify MAXROWS for a LOB table space, a table space that is implicitly created for an XML column, a table space in a work file database, or the Db2 catalog table spaces that are listed under [“SQL statements allowed on the catalog” on page 2739](#).

MAXPARTITIONS *integer*

Specifies that the table space is partition-by-growth. *integer* specifies the maximum number of partitions to which the table space can grow or shrink. *integer* must be in the range of 1 to 4096, depending on the value that is in effect for DSSIZE and the page size of the table space, and must not be less than the number of physical partitions that are already allocated for the table space. For more information about the relationship between DSSIZE, MAXPARTITIONS, buffer pool page size and table space size, see [“Maximum number of partitions and table space size ” on page 1340](#).

MAXPARTITIONS can be specified only for a simple table space that contains only one table, a segmented (non-UTS) table space that contains only one table, or a partitioned-by-growth table space. The table space must have Db2-managed data sets.

Depending on the situation when this clause is specified, Db2 might process the ALTER statement as a *pending data definition change*, which means the current object definition and data do not reflect the alteration at the time that the statement is issued. Instead, the altered object is placed in an advisory REORG-pending (AREOR) state, and a subsequent reorganization of the altered object with an appropriate utility materializes the changes to the catalog and data. For more information, see [Pending data definition changes \(Db2 Administration Guide\)](#).

Although physical data sets are not defined when the MAXPARTITIONS value is issued, there can be storage and CPU overhead. If an increase in the number of partitions is expected by using the MAXPARTITIONS clause, be aware that specifying a value larger than necessary, such as 4096 (the maximum value), as a default for all of your partition-by-growth table spaces can cause larger than expected storage requests.

FL 508If MAXPARTITIONS is specified on a simple or segmented (non-UTS) table space, the table space is converted to a partition-by-growth table space that can grow to a maximum number of *integer* partitions. If pending definition changes to move tables from the table space exist, *integer* must be 1. The SEGSIZE is set to the default of 32 if the SEGSIZE prior to conversion is less than 32. Otherwise, the value of SEGSIZE is inherited from the original table space. The DSSIZE is set to the default 4 gigabytes.

If the data sets of the table space are not defined, the number of partitions is set to 1 during the conversion to a partition-by-growth table space from a simple or segmented (non-UTS) table space.

When pending definition changes are specified for the BUFFERPOOL, DSSIZE, MAXPARTITIONS, or SEGSIZE attributes of partition-by-growth (PBG) table spaces, the number of partitions is determined based on the amount of existing data at the time the pending change is applied, and partition growth can occur. If LOB columns exist, additional LOB table spaces and auxiliary objects are implicitly created for the newly-created partitions independent of whether SQLRULES (DB2) or SQLRULES (STD) is in effect or whether the table space was explicitly or implicitly created. The new LOB objects inherit the buffer pool attribute and authorization from the existing LOB objects.

If the table space is defined with LOCKSIZE TABLE, the lock size will be reset to LOCKSIZE TABLESPACE during conversion to a partition-by-growth table space.

MEMBER CLUSTER YES or MEMBER CLUSTER NO

Specifies whether the table space uses the MEMBER CLUSTER page set structure. The MEMBER CLUSTER clause can be specified only for a partition-by-growth or partition-by-range table space, or

for a table space for which a pending definition change will convert the table space to a universal table space.

Depending on the situation when this clause is specified, Db2 might process the ALTER statement as a *pending data definition change*, which means the current object definition and data do not reflect the alteration at the time that the statement is issued. Instead, the altered object is placed in an advisory REORG-pending (AREOR) state, and a subsequent reorganization of the altered object with an appropriate utility materializes the changes to the catalog and data. For more information, see [Pending data definition changes \(Db2 Administration Guide\)](#).

MEMBER CLUSTER YES

Specifies that the MEMBER CLUSTER page set structure is to be used for the specified table space when the table space is already defined as a partition-by-growth or partition-by-range table space.

MEMBER CLUSTER YES cannot be specified for LOB, workfile, or XML table spaces, or for table spaces that are organized for hash access.

MEMBER CLUSTER NO

Specifies that the table space does not use the MEMBER CLUSTER page set structure when the table space is already defined as a partition-by-growth or partition-by-range table space. If the universal table space is already defined to use the MEMBER CLUSTER page set structure, specifying MEMBER CLUSTER NO on the ALTER TABLESPACE statement removes the MEMBER CLUSTER page set structure from the table space.

SEGSIZE *integer*

Specifies that the table space is a universal table space, where *integer* specifies the number of pages that are to be assigned to each segment of the table space. *integer* must be a multiple of 4 in the range 4–64 (inclusive). When SEGSIZE is specified, no other options are allowed in the same ALTER TABLESPACE statement.

SEGSIZE can be specified only for a universal table space or a partitioned table space that uses table-controlled partitioning.

Depending on the situation when this clause is specified, Db2 might process the ALTER statement as a *pending data definition change*, which means the current object definition and data do not reflect the alteration at the time that the statement is issued. Instead, the altered object is placed in an advisory REORG-pending (AREOR) state, and a subsequent reorganization of the altered object with an appropriate utility materializes the changes to the catalog and data. For more information, see [Pending data definition changes \(Db2 Administration Guide\)](#).

When pending definition changes are specified for the BUFFERPOOL, DSSIZE, MAXPARTITIONS, or SEGSIZE attributes of partition-by-growth (PBG) table spaces, the number of partitions is determined based on the amount of existing data at the time the pending change is applied, and partition growth can occur. If LOB columns exist, additional LOB table spaces and auxiliary objects are implicitly created for the newly-created partitions independent of whether SQLRULES (DB2) or SQLRULES (STD) is in effect or whether the table space was explicitly or implicitly created. The new LOB objects inherit the buffer pool attribute and authorization from the existing LOB objects.

If the existing FREEPAGE value (the number of pages to be left free) is greater than or equal to the new SEGSIZE value, the number of pages is adjusted to be one less than the new SEGSIZE value.

If the table space is a partitioned table space, the partitioned table space is converted to a partition-by-range (UTS) table space with a segment size specified by *integer*. The MEMBER CLUSTER attribute is inherited from the original table space. The number of partitions is inherited from the original table space. If the original DSSIZE attribute has a value of 0, the DSSIZE is set to the original maximum partition size. Otherwise, the DSSIZE attribute is inherited from the original table space.

TRACKMOD

Specifies whether Db2 tracks modified pages in the space map pages of the table space or partition. Do not specify TRACKMOD for a LOB table space or a table space in a work file database.

For the changed TRACKMOD option to take effect, the table space or partition needs to be stopped and restarted. The table space or partition can be stopped and restarted by running the STOP

DATABASE command followed by the START DATABASE command, or by running the REORG utility on the table space or partition. For more information, see [-STOP DATABASE command \(Db2\) \(Db2 Commands\)](#), [-START DATABASE command \(Db2\) \(Db2 Commands\)](#).

YES

Db2 tracks changed pages in the space map pages to improve the performance of incremental image copy. For data sharing, changing TRACKMOD to YES causes additional SCA (shared communication area) storage to be used until after the next full or incremental image copy is taken or until TRACKMOD is set back to NO.

NO

Db2 does not track changed pages in the space map pages. It uses the LRSN value in each page to determine whether a page has been changed.

FREEPAGE *integer*

Specifies how often to leave a page of free space when the table space is loaded or reorganized. One free page is left after every *integer* pages; *integer* can range 0–255. FREEPAGE 0 leaves no free pages. Do not specify FREEPAGE for a LOB table space, a table space that is implicitly created for an XML column, or a table space in a work file database.

If the table space is segmented, the number of pages left free must be less than the SEGSIZE value. If the number of pages to be left free is greater than or equal to the SEGSIZE value, then the number of pages is adjusted downward to one less than the SEGSIZE value.

This change to the description of the table space or partition has no effect until data in the table space or partition is loaded or reorganized.

For more information, see [“CURRENT TEMPORAL SYSTEM_TIME special register” on page 210](#).

[Reserving free space in table spaces \(Db2 Performance\)](#)

[Reserving free spaces for indexes \(Db2 Performance\)](#)

PCTFREE *smallint*

Specifies what percentage of each page to leave as free space when the table space is loaded or reorganized. The default value is PCTFREE 5, which specifies that 5% of the space on each data page is reserved as free space. The first record on each page is loaded without restriction. When additional records are loaded, at least *integer* percent of free space is left on each page. *integer* can range 0–99. Do not specify PCTFREE for a LOB table space, a table space that is implicitly created for an XML column, or a table space in a work file database.

FOR UPDATE *smallint*

Specifies the percentage of space to reserve as free space on each page, for use by subsequent UPDATE operations. The *smallint* value is an integer in the range -1 to 99. FOR UPDATE -1 specifies that 5% of free space is reserved initially, and the amount of free spaces is calculated automatically based on certain real-time statistics values. The first record on each page is always loaded without restriction.

If this value is not specified, the value of the PCTFREE_UPD subsystem parameter is used.

The value is recorded in the PCTFREE_UPD column of the SYSIBM.SYSTABLEPART catalog table.

The FOR UPDATE *smallint* values do not apply to LOB table spaces, XML table spaces, or table spaces that use hash organization.

The sum of the values for PCTFREE *smallint* and FOR UPDATE *smallint* must be less than or equal to 99.

If FOR UPDATE *smallint* is not specified and the sum of PCTFREE *smallint* and the PCTFREE_UPD subsystem parameter value is greater than or equal to 99, Db2 uses a smaller value for PCTFREE_UPD.

This change to the description of the table space or partition has no effect until data in the table space or partition is loaded or reorganized.

For more information, see [“CURRENT TEMPORAL SYSTEM_TIME special register” on page 210](#).

[Reserving free space in table spaces \(Db2 Performance\)](#)

[Reserving free spaces for indexes \(Db2 Performance\)](#)

USING

Specifies whether a data set for the table space or partition is managed by the user or is managed by the Db2 system. If the table space is partitioned, USING applies to the data set for the partition that is identified in the ALTER PARTITION clause. If the table space is a partition-by-growth table space, USING can be specified only at the table space level. If the table space is not partitioned, USING applies to every data set that is eligible for the table space. (A nonpartitioned table space can have more than one data set if PRIQTY+118 × SECQTY is at least 2 gigabytes.)

If the USING clause is specified, the table space or partition must be in the stopped state when the ALTER TABLESPACE statement is executed. See [Altering storage attributes](#) to determine how and when changes take effect. Do not specify the USING clause if the table space is in a work file database.

VCAT *catalog-name*

Specifies user-managed data sets for the table space.

The data sets are VSAM linear data sets cataloged in the integrated catalog facility catalog that *catalog-name* identifies. For more information about *catalog-name* values, see [“Naming conventions in SQL”](#) on page 79.

More than one Db2 subsystem can share the integrated catalog facility catalogs with the current server. To avoid the chance of those subsystems attempting to assign the same name to different data sets, specify a *catalog-name* value that is not used by the other Db2 subsystems.

The VCAT clause must not be specified if the table space is a partition-by-growth table space.

STOGROUP *stogroup-name*

Specifies a Db2-managed data set that resides on a volume of the identified storage group. *stogroup-name* must identify a storage group that exists at the current server and the privilege set must include SYSADM authority, SYSCtrl authority, or the USE privilege for the storage group. When the new description of the table space is applied, the description of the storage group must include at least one volume serial number, each volume serial number must identify a volume that is accessible to z/OS for dynamic allocation of the data set, and all identified volumes must be of the same device type. Furthermore, the integrated catalog facility catalog used for the storage group must not contain an entry for the data set.

If you specify USING STOGROUP and the current data set for the table space or partition is managed by Db2:

- Omission of the PRIQTY clause is an implicit specification of the current PRIQTY value.
- Omission of the SECQTY clause is an implicit specification of the current SECQTY value.
- Omission of the ERASE clause is an implicit specification of the current ERASE rule.

If you specify USING STOGROUP to convert from user-managed data sets to Db2-managed data sets:

- Omission of the PRIQTY clause is an implicit specification of the default value.
- Omission of the SECQTY clause is an implicit specification of the default value.
- Omission of the ERASE clause is an implicit specification of ERASE NO.

For more information, see [“Rules for primary and secondary space allocation”](#) on page 1337.

PRIQTY *integer*

Specifies the minimum primary space allocation for a Db2-managed data set of the table space or partition. *integer* must be a positive integer, or -1. This clause can be specified only if the data set is managed by Db2, and if one of the following is true:

- USING STOGROUP is specified.
- A USING clause is not specified.

In general, when you specify `PRIQTY` with a positive integer value, the primary space allocation is at least n kilobytes, where n is the value of *integer*. However, the following exceptions exist:

For non-LOB table spaces, the exceptions are:

- For 4KB page sizes, if *integer* is greater than 0 and less than 12, n is 12.
- For 8KB page sizes, if *integer* is greater than 0 and less than 24, n is 24.
- For 16KB page sizes, if *integer* is greater than 0 and less than 48, n is 48.
- For 32KB page sizes, if *integer* is greater than 0 and less than 96, n is 96.
- For any page size, if *integer* is greater than 67108864, n is 67108864.

For LOB table spaces, the exceptions are:

- For 4KB page sizes, if *integer* is greater than 0 and less than 200, n is 200.
- For 8KB page sizes, if *integer* is greater than 0 and less than 400, n is 400.
- For 16KB page sizes, if *integer* is greater than 0 and less than 800, n is 800.
- For 32KB page sizes, if *integer* is greater than 0 and less than 1600, n is 1600.
- For any page size, if *integer* is greater than 67108864, n is 67108864.

The maximum value allowed for `PRIQTY` is 64GB (67108864 kilobytes).

If you specify `PRIQTY` with a value of -1, Db2 uses a default value for the primary space allocation. For information on how Db2 determines the default value for primary space allocation, see [Rules for primary and secondary space allocation](#).

If `PRIQTY` is omitted and `USING STOGROUP` is specified, the value of `PRIQTY` is its current value. (However, if the current data set is being changed from being user-managed to Db2-managed, the value is its default value. See the description of `USING STOGROUP`.)

If you specify `PRIQTY`, and do not specify a value of -1, Db2 specifies the primary space allocation to access method services using the smallest multiple of p KB not less than n , where p is the page size of the table space. The allocated space can be greater than the amount of space requested by Db2. For example, it could be the smallest number of tracks that will accommodate the request. To more closely estimate the actual amount of storage, see [DEFINE CLUSTER command \(DFSMS Access Method Services for Catalogs\)](#).

At least one of the volumes of the identified storage group must have enough available space for the primary quantity. Otherwise, the primary space allocation will fail.

To determine how and when changes to `PRIQTY` take effect, see [“Altering storage attributes” on page 1337](#).

SECQTY integer

Specifies the minimum secondary space allocation for a Db2-managed data set of the table space or partition. *integer* must be a positive integer, 0, or -1. This clause can be specified only if the data set is managed by Db2, and if one of the following is true:

- `USING STOGROUP` is specified.
- A `USING` clause is not specified.

If you specify `SECQTY` with a value of -1, Db2 uses a default value for the secondary space allocation.

If `USING STOGROUP` is specified and `SECQTY` is omitted, the value of `SECQTY` is its current value. (However, if the current data set is being changed from being user-managed to Db2-managed, the value is its default value. See the description of `USING STOGROUP`.)

For information on the actual value that is used for secondary space allocation, whether you specify a value or Db2 uses a default value, see [“Rules for primary and secondary space allocation” on page 1337](#).

If you specify `SECQTY`, and do not specify a value of -1, Db2 specifies the secondary space allocation to access method services using the smallest multiple of p KB not less than *integer*, where p is the page size of the table space. The allocated space can be greater than the amount of space requested

by Db2. For example, it could be the smallest number of tracks that will accommodate the request. To more closely estimate the actual amount of storage, see the description of the [DEFINE CLUSTER command \(DFSMS Access Method Services for Catalogs\)](#) for z/OS DFSMS Access Method Services for catalogs.

To determine how and when changes to SECQTY take effect, see [“Altering storage attributes” on page 1337](#).

ERASE

Indicates whether the Db2-managed data sets for the table space or partition are to be erased before they are deleted during the execution of a utility or an SQL statement that drops the table space.

NO

Does not erase the data sets. Operations involving data set deletion will perform better than ERASE YES. However, the data is still accessible, though not through Db2.

YES

Erases the data sets. As a security measure, Db2 overwrites all data in the data sets with zeros before they are deleted.

This clause can be specified only if the data set is managed by Db2, and if one of the following is true:

- USING STOGROUP is specified.
- A USING clause is not specified.

If you specify ERASE, the table space or partition must be in the stopped state when the ALTER TABLESPACE statement is executed. If you specify ERASE for a partitioned table space, you must also specify the ALTER PARTITION clause. See [Altering storage attributes](#) to determine how and when changes take effect.

GBPCACHE

In a data sharing environment, specifies what pages of the table space or partition are written to the group buffer pool in a data sharing environment. In a non-data-sharing environment, you can specify GBPCACHE for a table space other than one in a work file database, but it is ignored. Do not specify GBPCACHE for a table space in a work file database in either environment (data sharing or not). In addition, you cannot alter the GBPCACHE value of some Db2 catalog table spaces; for a list of these table spaces, see [“SQL statements allowed on the catalog” on page 2739](#).

CHANGED

When there is inter-Db2 R/W interest on the table space or partition, updated pages are written to the group buffer pool. When there is no inter-Db2 R/W interest, the group buffer pool is not used. Inter-Db2 R/W interest exists when more than one member in the data sharing group has the table space or partition open, and at least one member has it open for update.

If the table space is in a group buffer pool that is defined to be used only for cross-invalidation (GBPCACHE NO), CHANGED is ignored and no pages are cached to the group buffer pool.

ALL

Indicates that pages are to be cached in the group buffer pool as they are read in from DASD.

Exception: In the case of a single updating Db2 when no other Db2 subsystems have any interest in the page set, no pages are cached in the group buffer pool.

If the table space is in a group buffer pool that is defined to be used only for cross-invalidation (GBPCACHE NO), ALL is ignored and no pages are cached to the group buffer pool.

SYSTEM

Indicates that only changed system pages within the LOB table space are to be cached to the group buffer pool. A system page is a space map page or any other page that does not contain actual data values.

Use SYSTEM only for a LOB table space.

NONE

Indicates that no pages are to be cached to the group buffer pool. Db2 uses the group buffer pool only for cross-invalidation.

If you specify NONE, the table space or partition must not be in recover pending status when the ALTER TABLESPACE statement is executed.

If you specify GBPCACHE in a data sharing environment, the table space or partition must be in the stopped state when the ALTER TABLESPACE statement is executed.

PAGENUM

Specifies the type of page numbering that is used when you alter a partition-by-range table space.

RELATIVE

Indicates that internal page numbering is kept as a 4-byte value without a partition number. The page number is a relative page from the start of the partition, and the partition number is kept only in the header page.

The table space cannot be altered to relative page numbering if the table has truncated limit key values.

Depending on the situation when this clause is specified, Db2 might process the ALTER statement as a *pending data definition change*, which means the current object definition and data do not reflect the alteration at the time that the statement is issued. Instead, the altered object is placed in an advisory REORG-pending (AREOR) state, and a subsequent reorganization of the altered object with an appropriate utility materializes the changes to the catalog and data. For more information, see [Pending data definition changes \(Db2 Administration Guide\)](#).

ALTER PARTITION *integer*

Specifies that the identified partition of the table space is to be changed. For a table space that has n partitions, you must specify an integer in the range 1 to n . You must not use this clause for a nonpartitioned table space, for a LOB table space, or a partition-by-growth table space. At least one of the following clauses must be specified:

- COMPRESS
- DSSIZE
- ERASE
- FREEPAGE
- GBPCACHE
- PCTFREE
- PRIQTY
- SECQTY
- TRACKMOD
- USING

The changes specified by these clauses affect only the identified partition.

Do not specify the following clauses for ALTER PARTITION for partitions of a table space that is implicitly created for an XML column.

- CCSID
- FREEPAGE
- MAXROWS
- PCTFREE

MOVE TABLE *table-name* TO TABLESPACE *dbname.new-tsname*

[FL 508](#) Specifies that the table that is specified by *table-name* is to be moved to another table space. *new-tsname* specifies the target table space to which the table is to be moved, and *dbname* specifies the database that contains the target table space. Omission of *dbname* is an implicit specification of DSNDB04. The privilege set must include SYSADM or SYSCTRL authority or the USE privilege for the buffer pool and storage group that are used by the target table space.

The table that is specified by *table-name* must meet the following requirements:

- Exist at the current server
- Be defined in the source table space
- Not specify a view
- If the alteration is a pending change, be in a complete state
- Not have an OBID value of 1

The source table space that is specified in *database-name.table-space-name* must meet the following requirements:

- Not be a catalog or directory table space
- Not be a table space in the work file database
- Be a simple or segmented (non-UTS) table space

The target table space that is specified in *dbname.new-tspace* must meet the following requirements:

- Not be a catalog or directory table space
- Exist in the same database as the source table space
- Be a universal partition-by-growth table space
- Not already have data sets created
- Be defined with MAXPARTITIONS 1
- Have the same encoding scheme and CCSID triplet as the source table space
- Be defined with a buffer pool that has a page size that can accommodate the record length of the moved table
- Be defined with the same LOGGED attribute as the source table space

Depending on the situation when this clause is specified, Db2 might process the ALTER statement as a *pending data definition change*, which means the current object definition and data do not reflect the alteration at the time that the statement is issued. Instead, the altered object is placed in an advisory REORG-pending (AREOR) state, and a subsequent reorganization of the altered object with an appropriate utility materializes the changes to the catalog and data. For more information, see [Pending data definition changes \(Db2 Administration Guide\)](#).

Taking either of the following actions before you run the REORG utility to apply a pending MOVE TABLE operation will cause the REORG job to fail:

- Altering the target table space so that its attributes become invalid for a MOVE TABLE operation
- Dropping and re-creating the target table space, regardless of whether the table space attributes are valid

For information on moving tables from deprecated table spaces, see [Moving tables from multi-table table spaces to partition-by-growth table spaces \(Db2 Administration Guide\)](#).

Notes for ALTER TABLESPACE

ALTER TABLESPACE and insert operations in the same commit scope

You might encounter problems when an ALTER TABLESPACE statement is followed by an insert operation in the same commit scope. If that happens, add a COMMIT statement between the ALTER TABLESPACE and insert operations.

Running utilities

You cannot execute the ALTER TABLESPACE statement while a Db2 utility has control of the table space.

Altering more than one partition

To change FREEPAGE, PCTFREE, USING, PRIQTY, SECQTY, ERASE, or GBPCACHE for more than one partition, you must use separate ALTER TABLESPACE statements.

Rules for primary and secondary space allocation

You can specify the primary and secondary space allocation or let Db2 choose them. Having Db2 choose the values, especially the secondary space quantity, increases the possibility of reaching the maximum data set size before running out of extents. For more information, see [Rules for primary and secondary space allocation \(Introduction to Db2 for z/OS\)](#).

Altering storage attributes

The USING, PRIQTY, SECQTY, and ERASE clauses define the storage attributes of the table space or partition. If you specify USING or ERASE when altering storage attributes, the table space or partition must be in the stopped state when the ALTER TABLESPACE statement is executed. You can use a STOP DATABASE...SPACENAM... command to stop the table space or partition.

If the catalog name changes, the changes take effect after you move the data and start the table space or partition using the START DATABASE...SPACENAM... command. The catalog name can be implicitly or explicitly changed by the ALTER TABLESPACE statement. The catalog name also changes when you move the data to a different device. See the procedures in [Tools for moving Db2 data \(Db2 Administration Guide\)](#).

Changes to the secondary space allocation (SECQTY) take effect the next time Db2 extends the data set; however, the new value is not reflected in the integrated catalog until you use the REORG, RECOVER, or LOAD REPLACE utility on the table space or partition. The changes to the other storage attributes take effect the next time the page set is reset. For a non-LOB table space, the page set is reset when you use the REORG, RECOVER, or LOAD REPLACE utilities on the table space or partition. For a LOB table space, the page set is reset when RECOVER is run on the LOB table space or LOAD REPLACE is run on its associated base table space. If there is not enough storage to satisfy the primary space allocation, a REORG might fail. If you change the primary space allocation parameters or erase rule, you can have the changes take effect earlier if you move the data before you start the table space or partition.

Recommended GBPCACHE setting for LOB table spaces

For LOB table spaces, use the GBPCACHE CHANGED option instead of the GBPCACHE SYSTEM option. Due to the usage patterns of LOBs, the use of GBPCACHE CHANGED can help avoid excessive and synchronous writes to disk and the group buffer pool.

Increasing the size of a partitioned table space

Depending on the needs of your applications, you might need to increase the size of a partitioned table space by taking one of the following actions:

- [Adding partitions \(Db2 Administration Guide\)](#)
- [Increasing partition size \(Db2 Administration Guide\)](#)

Altering table spaces for tables that use hash organization

Certain attributes of the table space, such as buffer pool and page size, might affect performance of tables that use hash organization. Changes related to the hash organization of a table will be validated and might generate error messages as described in [“CREATE TABLE statement” on page 1650](#) and [“ALTER TABLE statement” on page 1232](#).

Deprecated function: FL 504 Hash-organized tables are deprecated. Beginning in Db2 12, packages bound with APPLCOMPAT(V12R1M504) or higher cannot create hash-organized tables or alter existing tables to use hash-organization. Existing hash organized tables remain supported, but they are likely to be unsupported in the future.

Altering the logging attribute of a table space

If the logging attribute (specified with the LOGGED or NOT LOGGED parameter) of a table space is altered frequently, the size of SYSIBM.SYSCOPY might need to be increased.

The logging attribute of the table space cannot be altered if the table space has been updated in the same unit of recovery.

A full image copy of the table space should be taken:

- Before altering a table space to NOT LOGGED
- After altering a table space to LOGGED

If a table space has data changes after an image copy is taken (the table space is in informational COPY-pending state), and the table space is altered from NOT LOGGED to LOGGED, the table space is marked COPY-pending and a full image copy of the table space must be taken.

An XML table space with the LOGGED logging attribute has its logging attribute altered to NOT LOGGED when the logging attribute of the associated base table space is altered from LOGGED to NOT LOGGED. When this happens, the logging attribute of the XML table space is said to be *linked* to the logging attribute of the base table space. When the logging attribute of the base table space is altered back to LOGGED, all logging attributes that are linked for the associated XML table spaces are altered back to LOGGED, and all of these links are dissolved.

A LOB table space with the LOGGED logging attribute has its logging attribute altered to NOT LOGGED when the logging attribute of the associated base table space is altered from LOGGED to NOT LOGGED. When this happens, the logging attribute of the LOB table space is said to be *linked* to the logging attribute of the base table space. When the logging attribute of the base table space is altered back to LOGGED, all logging attributes that are linked for the associated LOB table spaces are altered back to LOGGED, and all of these links are dissolved.

You can dissolve the link between these logging attributes by altering the logging attribute of the LOB table space to NOT LOGGED, even though it has already been implicitly given this logging attribute. After such an alter, the logging attribute of the LOB table space is unaffected when the logging attribute of the base table is altered back to LOGGED. A LOB table space with the NOT LOGGED logging attribute does not have this attribute changed in any way if the logging attribute of the associated base table space is altered from LOGGED to NOT LOGGED. When altered in this way, the logging attributes of the LOB table space and the base table space are not linked. If the base table space is altered back to LOGGED, the logging attribute of any LOB table spaces that are not linked to the logging attribute of the base table space remain unchanged.

Altering table spaces for Db2 catalog tables

For details on altering options on catalog tables, see [“SQL statements allowed on the catalog” on page 2739](#).

Invalidation of packages:

This statement might invalidate all packages that depend on target objects, and sometimes other related objects through cascading effects, depending on the clauses and keywords specified and other factors. For more information, see [Changes that invalidate packages \(Db2 Application programming and SQL\)](#).

Pending data definition changes

The following table lists clauses and specific conditions that cause an ALTER TABLESPACE statement to be processed as a pending definition change. The changes are not reflected in the definition or data at the time the ALTER TABLESPACE statement is issued. Instead, the entire table space is placed in an advisory REORG-pending state (AREOR). A subsequent reorganization of the entire table space applies the pending definition changes to the definition and data of the table space. The definition of the table space must not be in an incomplete state.

Clause or option	Pending definition change used if...
BUFFERPOOL	The data sets of the table space are already created, and any of the following conditions are true: <ul style="list-style-type: none"> • Pending definition changes already exist for the table space or any objects within the base table space. • The specified buffer pool has a different page size than the buffer pool that is currently being used for the table space.
DSSIZE	The data sets of the table space are already created, and any of the following conditions are true: <ul style="list-style-type: none"> • Pending definition changes already exist for the table space or for any objects in the table space.

Clause or option	Pending definition change used if...
	<ul style="list-style-type: none"> The table space uses relative page numbering, and the DSSIZE value that is specified at the table space level is smaller than the value that is currently being used for one or more of the partitions in the table space. The table space uses absolute page numbering, and the specified DSSIZE value is different than the value that is currently being used for the table space.
MAXPARTITIONS	If the data sets of the table space are already created and the table space is not a PBG table space.
MEMBER CLUSTER	<p>If the data sets of the table space are already created and any of the following conditions are true:</p> <ul style="list-style-type: none"> Pending definition changes already exist for the table space or any objects in the table space. The MEMBER CLUSTER attribute is changed to a different value.
FL 508 MOVE TABLE	The data sets of the altered table space are already created.
PAGENUM	<p>The change to the PAGENUM attribute is a pending change to the definition of the table space if the data sets of the table space are already created and if one of the following conditions is true:</p> <ul style="list-style-type: none"> Pending definition changes already exist for the table space or any associated indexes. The specified PAGENUM attribute is different from the value that is currently being used for the table space.
SEGSIZE	<p>The data sets of the table space are already created, and any of the following conditions are true:</p> <ul style="list-style-type: none"> Pending definition changes already exist for the definition of the table space or any objects in the table space. The specified SEGSIZE value for a universal table space is different than the existing value. The table space is converted from a partitioned (non-UTS) table space to a partition-by-range table space.

When pending definition changes are specified for the BUFFERPOOL, DSSIZE, MAXPARTITIONS, or SEGSIZE attributes of partition-by-growth (PBG) table spaces, the number of partitions is determined based on the amount of existing data at the time the pending change is applied, and partition growth can occur. If LOB columns exist, additional LOB table spaces and auxiliary objects are implicitly created for the newly-created partitions independent of whether SQLRULES (DB2) or SQLRULES (STD) is in effect or whether the table space was explicitly or implicitly created. The new LOB objects inherit the buffer pool attribute and authorization from the existing LOB objects.

For more information, see [Pending data definition changes \(Db2 Administration Guide\)](#).

Restrictions for pending data definition changes

The following restrictions apply to ALTER TABLESPACE, ALTER TABLE, and ALTER INDEX statements that result in pending data definition changes:

- Options that cause pending changes cannot be specified with options that take effect immediately.
- Options that cause pending changes cannot be specified for the Db2 catalog, other system objects, or objects in a work file database.
- The DROP PENDING CHANGES clause of the ALTER TABLESPACE statement cannot be specified for a catalog table space.

- If the table space, or any table it contains is in an incomplete state, you cannot specify options that cause pending changes.
- For ALTER INDEX, options that cause pending changes cannot be specified if the definition of the table space or table on which the index is defined is not complete.

Also, many alter operations are restricted for a table space that has existing pending data definition changes for the table space, the table it contains, or indexes on the table. For more information, see [Restrictions for pending data definition changes \(Db2 Administration Guide\)](#).

Maximum number of partitions and table space size

For partition-by-range table spaces created with relative page numbering, the maximum number of partitions is 4096. For partition-by-range table spaces with absolute page numbering or partition-by-growth table spaces, the following tables show how the maximum number of partitions and the total table space size depend on the buffer pool page size and DSSIZE value, with 5-byte extended addressability (EA) storage. ¹ on page 1341

4 KB page size

Table 186. Maximum number of partitions and table space size by DSSIZE, with 4 KB page size

DSSIZE	Maximum number of partitions	Total table space size
1G	4096	4 TB
2G	4096	8 TB
4G	4096	16 TB
8G	2048	16 TB
16G	1024	16 TB
32G	512	16 TB
64G	256	16 TB
128G	128	16 TB
256G	64	16 TB

8 KB page size

Table 187. Maximum number of partitions and table space size by DSSIZE, with 8 KB page size

DSSIZE	Maximum number of partitions	Total table space size
1G	4096	4TB
2G	4096	8TB
4G	4096	16TB
8G	4096	32TB
16G	2048	32TB
32G	1024	32TB
64G	512	32TB
128G	256	32TB
256G	128	32TB

16 KB page size

Table 188. Maximum number of partitions and table space size by DSSIZE, with 16 KB page size

DSSIZE	Maximum number of partitions	Total table space size
1G	4096	4 TB
2G	4096	8 TB
4G	4096	16 TB
8G	4096	32 TB
16G	4096	64 TB
32G	2048	64 TB
64G	1024	64 TB
128G	512	64 TB
256G	256	64 TB

32 KB page size

Table 189. Maximum number of partitions and table space size by DSSIZE, with 32 KB page size

DSSIZE	Maximum number of partitions	Total table space size
1G	4096	4 TB
2G	4096	8 TB
4G	4096	16 TB
8G	4096	32 TB
16G	4096	64 TB
32G	4096	128 TB
64G	2048	128 TB
128G	1024	128 TB
256G	512	128 TB

Notes:

1. For 5-byte non-EA storage, the maximum values for 4 KB page size are DSSIZE 4 G, 4096 partitions, and 16 TB for total table space.

Alternative syntax and synonyms

For compatibility with previous releases of Db2, the following keywords are supported:

- You can specify the LOCKPART clause, but it has no effect. Db2 treats all partitioned table spaces as if they were defined as LOCKPART YES. LOCKPART YES specifies the use of selective partition locking. When all the conditions for selective partition locking are met, Db2 locks only the partitions that are accessed. When the conditions for selective partition locking are not met, Db2 locks every partition of the table space.
- When altering the partitions of a partitioned table space, the ALTER keyword that precedes the PARTITION keyword is optional and if the ALTER keyword is omitted, then you can specify PART as a synonym for PARTITION.
- You can specify LOG YES as a synonym for LOGGED and LOG NO as a synonym for NOT LOGGED.

Examples for ALTER TABLESPACE

Example 1

Alter table space DSN8S12D in database DSN8D12A. BP2 is the buffer pool associated with the table space. PAGE is the level at which locking is to take place.

```
ALTER TABLESPACE DSN8D12A.DSN8S12D
  BUFFERPOOL BP2
  LOCKSIZE PAGE;
```

Example 2

Alter table space DSN8S12E in database DSN8D12A. The table space is partitioned. Indicate that the data sets of the table space are not to be closed when there are no current users of the table space. Also, change all of the partitions so that Db2 will use a formula to determine any secondary space allocations, and change partition 1 to use a PCTFREE value of 20.

```
ALTER TABLESPACE DSN8D12A.DSN8S12E
  CLOSE NO
  SECQTY -1
  ALTER PARTITION 1 PCTFREE 20;
```

Example 3

The following statement changes the maximum number of partitions in a partition-by-growth table space:

```
ALTER TABLESPACE TS01DB.TS01TS
  MAXPARTITIONS 30;
```

ALTER TRIGGER statement (advanced trigger)

The ALTER TRIGGER (advanced) statement changes the description of an advanced trigger at the current server.

For a description of the differences between basic and advanced triggers, see [Triggers \(Introduction to Db2 for z/OS\)](#).

Invocation for ALTER TRIGGER (advanced)

This statement can be issued interactively. It is an executable statement that can be dynamically prepared only if DYNAMICRULES RUN behavior is in effect. For more information, see [“Authorization IDs and dynamic SQL”](#) on page 94.

Authorization for ALTER TRIGGER (advanced)

The privilege set that is defined below must include at least one of the following:

- Ownership of the trigger
- The ALTERIN privilege on the schema
- System DBADM authority
- SYSCTRL authority
- SYSADM authority
- Installation SYSOPR authority (when the current SQLID of the process is set to SYSINSTL)

The authorization ID that matches the schema name implicitly has the ALTERIN privilege on the schema.

Additional privileges might be required in the following situations:

- If *trigger-specification* is specified:
 - The privilege set must include at least one of the following:

- Ownership of the trigger
- DATAACCESS authority
- SYSADM authority
- The owner of the trigger must have SYSADM authority or each one of the following:
 - The SELECT privilege on the table or view on which the trigger is defined.
 - The SELECT privilege on any table or view in the *search-condition* of the *triggered-action*.
 - The privileges that are required to execute the statements in *SQL-trigger-body*
- If the SECURED option is specified, the privilege set must include SECADM authority or the CREATE_SECURE_OBJECT privilege.
- If the WLM ENVIRONMENT FOR DEBUG MODE clause is specified, RACF or an external security product is invoked to check the required authority for defining programs in the WLM environment. If the WLM environment access is protected in RACF, the user that issued the ALTER statement must have the required authority.

Additional authorization may be required on the SYSDUMMYx tables depending on the content of the trigger definition. See SYSDUMMYx tables.

Privilege set: The privilege set is the set of privileges that are held by the SQL authorization ID of the process. The specified trigger name can include a schema name (a qualifier). However, if the schema name is not the same as one of the authorization ID of the process, one of the following conditions must be met:

- The privilege set includes SYSADM authority, SYSCTRL authority, or system DBADM authority.
- The authorization ID of the process has the ALTERIN privilege on the schema.

Note: If the SEPARATE SECURITY subsystem parameter is set to NO, SYSADM authority has implicit SECADM authority.

Syntax for ALTER TRIGGER (advanced)

► ALTER TRIGGER — *trigger-name* →

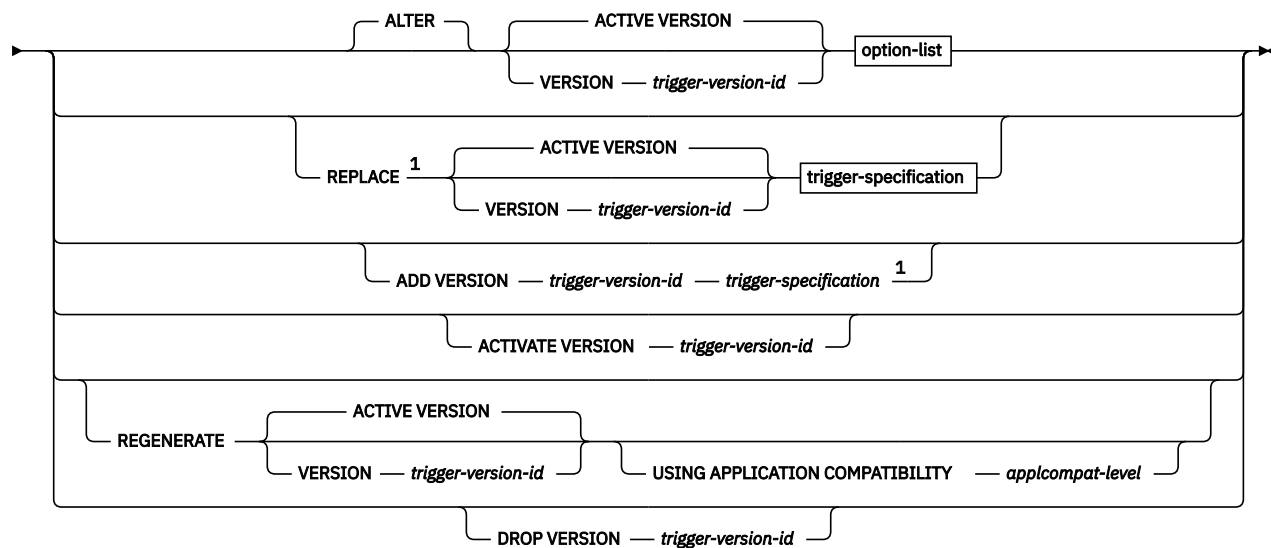

Notes:

¹ An ALTER TRIGGER statement with an ADD VERSION or REPLACE clause is not allowed in an *SQL-trigger-body*.

trigger-specification:

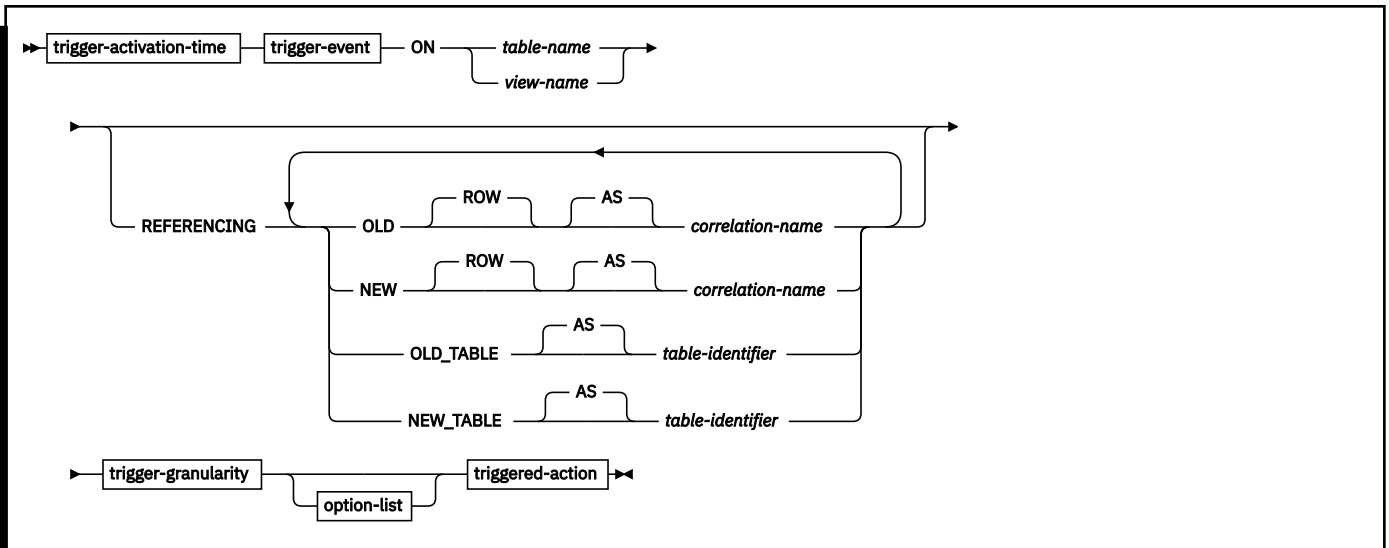

trigger-activation-time

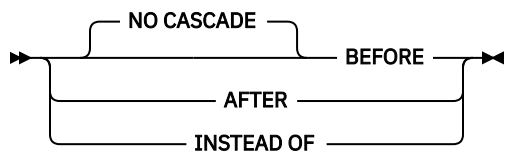

trigger-event

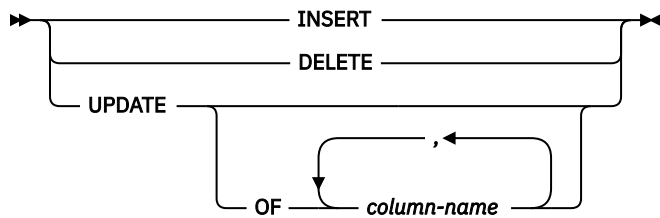

trigger-granularity

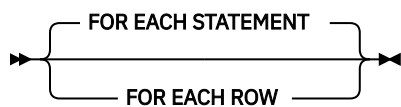

option-list: (The options can be specified in any order, but each one can only be specified one time.)

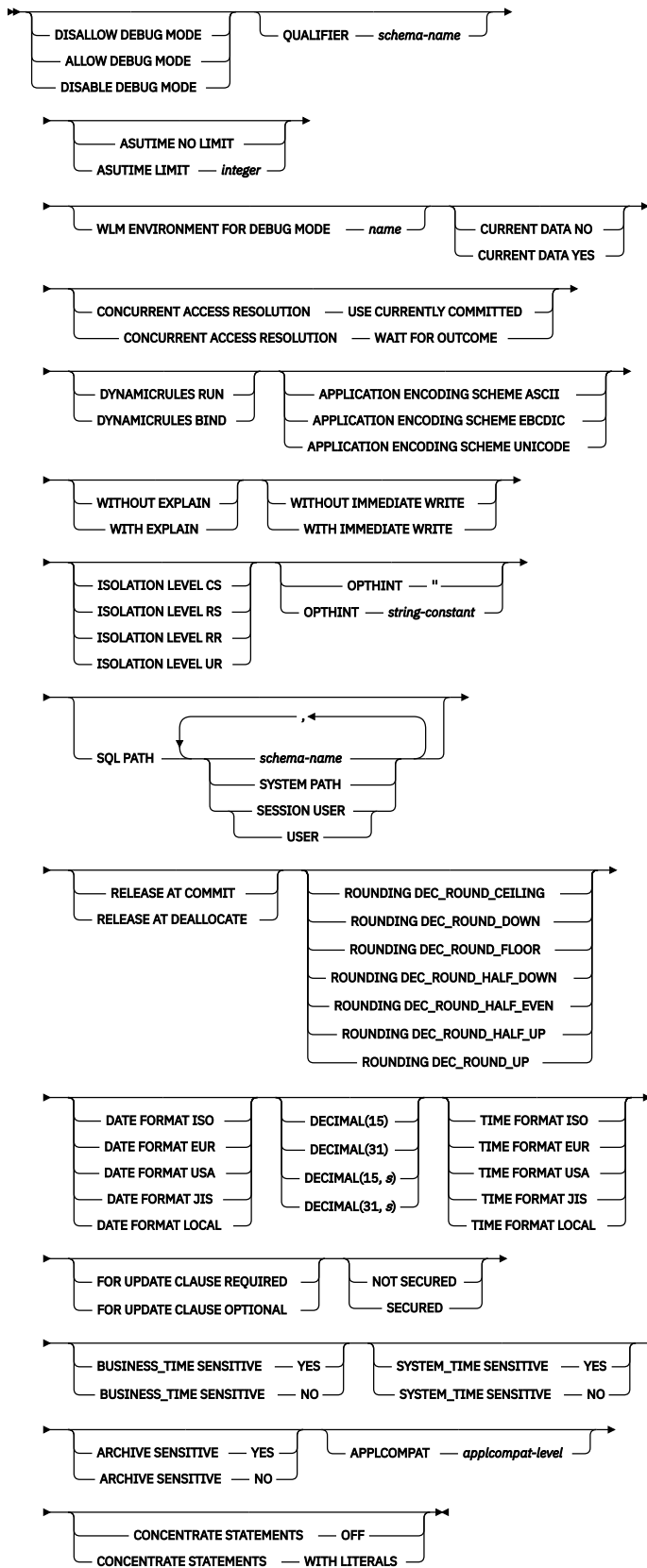

triggered-action

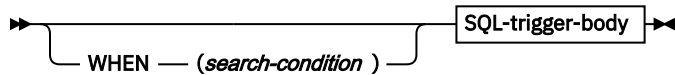

SQL-trigger-body

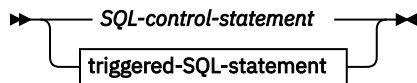

Description for ALTER TRIGGER (advanced)

trigger-name

Identifies the trigger that is to be changed. The name, including the implicit or explicit schema name, must exist at the current server. The name must identify an advanced trigger.

The trigger must not be obfuscated.

ACTIVE VERSION or VERSION trigger-version-id

Identifies the version of the trigger that is to be changed, replaced, or regenerated depending on whether the ALTER, REPLACE, or REGENERATE keyword is specified.

ACTIVE VERSION

Specifies that the currently active version of the trigger is to be changed, replaced, or regenerated.

VERSION trigger-version-id

Identifies the version of the trigger that is to be changed, replaced, or regenerated. *trigger-version-id* is the version identifier that is assigned when the version is defined. *trigger-version-id* must identify a version of the specified trigger that exists at the current server.

USING APPLICATION COMPATIBILITY applcompat-level

Specifies the application compatibility level used to regenerate the version of the trigger. The ALTER statement returns an error if the existing definition of the version includes syntax, semantics, or options that require a higher application compatibility level. This situation can occur when the version was most recently defined or regenerated while running at a higher application compatibility level than *applcompat-level*.

The following values can be specified:

VuuRrMmmm

Compatibility with the behavior of the identified Db2 function level. For example, V12R1M510 specifies compatibility with the highest available Db2 12 function level. The equivalent function level or higher must be activated.

For the new capabilities that become available in each application compatibility level, see:

- [SQL changes in Db2 13 application compatibility levels](#)
- [SQL changes in Db2 12 application compatibility levels](#)

Tip: Extra program preparation steps might be required to increase the application compatibility level for applications that use data server clients or drivers to access Db2 for z/OS. For more information, see [Setting application compatibility levels for data server clients and drivers \(Db2 Application programming and SQL\)](#).

V12R1

Compatibility with the behavior of Db2 12 function level 500. This value has the same result as specifying V12R1M500.

ALTER

Specifies that the trigger is to be changed. When you change one or more trigger options, any option that is not explicitly specified uses the existing value from the trigger that is being changed.

REPLACE

Specifies that a version of the trigger is to be replaced.

When you replace a trigger, the following trigger attributes must be the same as the corresponding attributes for the currently active version of the trigger: *trigger-activation-time*, *trigger-event*, table or view name, and *trigger-granularity*.

The content of the REFERENCING clause can differ from the other versions of the trigger. For options that are not explicitly specified, the system default values for those options are used, even if those options were explicitly specified for the version of the trigger that is being replaced. This is not the case for versions of the trigger that specified DISABLE DEBUG MODE. If DISABLE DEBUG MODE is specified for a version of a trigger, the option cannot be changed using the REPLACE clause. When a trigger definition is replaced, any existing comments in the catalog for that definition of the trigger are removed.

Binding the replaced version of the trigger might result in a new access path even if the trigger body is not changed.

ADD VERSION *trigger-version-id*

Specifies that a new version of the trigger is to be created. *trigger-version-id* is the version identifier for the new version of the trigger. *trigger-version-id* must not identify a version of the specified trigger that already exists at the current server.

When you add a new version of a trigger, the following trigger attributes must be the same as the corresponding attributes for the currently active version of the trigger: *trigger-activation-time*, *trigger-event*, table or view name, and *trigger-granularity*. The content of the REFERENCING clause can differ from the other versions of the trigger. For options that are not explicitly specified, the system default values are used.

ACTIVATE VERSION *trigger-version-id*

Specifies the version of the trigger that is to be the currently active version of the trigger. *trigger-version-id* is the version identifier that is assigned when the version of the trigger is defined. The version that is specified with *trigger-version-id* is the version that will be invoked when the trigger is activated. *trigger-version-id* must identify a version of the trigger that already exists at the current server.

REGENERATE

Specifies that the trigger package is to be regenerated.

The REGENERATE keyword on the ALTER TRIGGER statement is used to rebind the SQL control statements, as well as non-SQL-control statements that are included in the trigger body, at the local server. When a trigger is regenerated, any unqualified names in the trigger body are resolved using the name resolution process.

Using an ALTER TRIGGER statement with the REGENERATE keyword is different from a REBIND PACKAGE command. The REBIND PACKAGE command rebinds only the non-SQL-control statements to generate better access paths for those statements, using the statement text from the SYSIBM.SYSPACKSTMTS catalog table.

When a trigger definition is regenerated, any existing comments in the catalog for that definition of the trigger are not removed.

Generally, the REGENERATE keyword is used only for specific situations, such as when implicit regeneration fails for routines or objects, or Db2 maintenance requires objects or routines to be regenerated. For more information, see [When to regenerate Db2 database objects and routines \(Db2 Administration Guide\)](#).

DROP VERSION *trigger-version-id*

Drops the version of the trigger that is identified with *trigger-version-id*. *trigger-version-id* is the version identifier that is assigned when the version is defined. *trigger-version-id* must identify a

version of the trigger that already exists at the current server and must not identify the currently active version of the trigger. Only the identified version of the trigger is dropped.

When only a single version of the trigger exists at the current server, use the DROP TRIGGER statement to drop the trigger.

trigger-event

Specifies that the triggered action that is associated with the trigger is to be executed when the trigger event is applied to the subject table or view.

INSERT

Specifies that the trigger is an insert trigger. Db2 executes the triggered action whenever there is an insert operation on the subject table. However, if the insert trigger is defined on any explain table, and the insert operation was caused by Db2 adding a row to the table, the triggered action is not executed.

DELETE

Specifies that the trigger is a delete trigger. Db2 executes the triggered action whenever there is a delete operation on the subject table.

UPDATE

Specifies that the trigger is an update trigger. Db2 executes the triggered action whenever there is an update operation on the subject table.

If you do not specify a list of column names, an update operation on any column of the subject table, including columns that are subsequently added with the ALTER TABLE statement, activates the triggered action.

OF column-name,...

Each *column-name* that you specify must be a column of the subject table and must appear in the list only once. An update operation on any of the listed columns activates the triggered action.

UPDATE OF *column-name* cannot be specified for an INSTEAD OF trigger.

trigger-activation-time

NO CASCADE

NO CASCADE is allowed for compatibility with prior releases and other products.

BEFORE

Specifies that the trigger is a before trigger. Db2 executes the triggered action before it applies any changes caused by an insert, delete, or update operation on the subject table. It also specifies that the triggered action does not activate other triggers because the triggered action of a before trigger cannot contain any updates, REFRESH TABLE, or TRUNCATE SQL statements.

BEFORE must not be specified when *view-name* is also specified. FOR EACH ROW must be specified for a BEFORE trigger.

AFTER

Specifies that the trigger is an after trigger. Db2 executes the triggered action after it applies any changes caused by an insert, delete, or update operation on the subject table. AFTER must not be specified if *view-name* is also specified.

INSTEAD OF

Specifies that the trigger is an instead of trigger. The associated triggered action replaces the action against the subject view. Only one INSTEAD OF trigger is allowed for each type of operation on a given subject view. Db2 executes the *triggered-action* instead of the insert, update, or delete operation on the subject view.

INSTEAD OF must not be specified when *table-name* is also specified. The WHEN clause can not be specified for an INSTEAD OF trigger. FOR EACH ROW must be specified for an INSTEAD OF trigger.

REFERENCING

Specifies the correlation names for the transition variables and the table names for the transition tables. For the rows in the subject table that are modified by the triggering SQL operation (insert, delete, or update), a correlation name identifies the columns of a specific row. *table-identifiers* identify the complete set of affected rows. Transition variables with XML types cannot be referenced inside of a trigger. If the column of a transition table is referenced, the data type of the column cannot be XML.

Each row that is affected by the triggering SQL operation is available to the triggered action by qualifying column names with *correlation-names* that are specified as follows:

OLD ROW AS *correlation-name*

Specifies the correlation name that identifies the transition variables containing the values in the row prior to the triggering SQL operation.

NEW ROW AS *correlation-name*

Specifies the correlation name that identifies the transition variables containing the values in the row as modified by the triggering SQL operation and by any assignment statement in a before trigger that has already been executed.

If OLD and NEW are both specified, a reference to a transition variable must be qualified with the associated correlation name.

The complete set of rows that are affected by the triggering operation is available as a transition table to the triggered action. Specify a *table-identifier* to refer to the transition table as follows:

OLD_TABLE AS *table-identifier*

Specifies the name of a temporary table that identifies the values in the complete set of rows that are modified rows by the triggering SQL operation prior to any actual changes.

NEW_TABLE AS *table-identifier*

Specifies the name of a temporary table that identifies the values in the complete set of rows as modified by the triggering SQL operation and by any assignment statement in a before trigger that has already been executed.

Only one OLD and one NEW *correlation-name* can be specified for a trigger. Only one OLD_TABLE and one NEW_TABLE *table-identifier* can be specified for a trigger. All of the *correlation-names* and *table-identifiers* must be unique from one another.

Table 190 on page 1350 summarizes the allowable combinations of transition variables and transition tables that you can specify for the various trigger types. The OLD *correlation-name* and the OLD_TABLE *table-identifier* are valid only if the triggering event is either a delete operation or an update operation. For a delete operation, the OLD *correlation-name* captures the values of the columns in the deleted row, and the OLD_TABLE *table-identifier* captures the values in the set of deleted rows. For an update operation, the OLD *correlation-name* captures the values of the columns of a row before the update operation, and the OLD_TABLE *table-identifier* captures the values in the set of rows before the update operation.

The NEW *correlation-name* and the NEW_TABLE *table-identifier* are valid only if the triggering event is either an insert operation or an update operation. For both operations, the NEW *correlation-name* captures the values of the columns in the inserted or updated row and the NEW_TABLE *table-identifier* captures the values in the set of inserted or updated rows. For BEFORE triggers, the values of the updated rows include the changes from any assignment statements in the triggered action of BEFORE triggers.

Table 190. Allowable combinations of attributes in a trigger definition

Granularity	Activation time	Triggering SQL operation	Transition variables allowed“1” on page 1350	Transition tables allowed“1” on page 1350
FOR EACH ROW	BEFORE	DELETE	OLD	None
		INSERT	NEW	None
		UPDATE	OLD, NEW	None
	AFTER	DELETE	OLD	OLD_TABLE
		INSERT	NEW	NEW_TABLE
		UPDATE	OLD, NEW	OLD_TABLE, NEW_TABLE
	INSTEAD OF	DELETE	OLD	OLD_TABLE
		INSERT	NEW	NEW_TABLE
		UPDATE	OLD, NEW	OLD_TABLE, NEW_TABLE
FOR EACH STATEMENT	AFTER	DELETE	None	OLD_TABLE
		INSERT	None	NEW_TABLE
		UPDATE	None	OLD_TABLE, NEW_TABLE

Note:

1. If a transition table or variable is referenced where it is not allowed, an error is returned.

A transition variable that has a character data type inherits the subtype and CCSID of the column of the subject table. During the execution of the triggered action, the transition variables are treated like host variables. Therefore, character conversion might occur. However, unlike a host variable, a transition variable can have the bit data attribute, and character conversion never occurs for bit data. A transition variable is considered to be bit data if the column of the table to which it corresponds is bit data.

You cannot modify a transition table; transition tables are read-only. Although a transition table does not inherit any edit or validation procedures from the subject table, it does inherit the encoding scheme and field procedures of the subject table.

The scope of each *correlation-name* and each *table-identifier* is the entire trigger definition.

trigger-granularity

FOR EACH ROW or FOR EACH STATEMENT

Specifies the conditions for which Db2 executes the triggered action.

FOR EACH ROW

Specifies that Db2 executes the triggered action for each row of the subject table that the triggering SQL operation modifies. If the triggering SQL operation does not modify any rows, the triggered action is not executed..

FOR EACH STATEMENT

Specifies that Db2 executes the triggered action only one time for the triggering operation. Even if the triggering operation does not modify or delete any rows, the triggered action is executed one time.

FOR EACH STATEMENT must not be specified for a BEFORE or INSTEAD OF trigger.

ALLOW DEBUG MODE, DISALLOW DEBUG MODE, or DISABLE DEBUG MODE

Specifies whether this version of the trigger can be run in debugging mode. The default is determined using the value of the CURRENT DEBUG MODE special register.

ALLOW DEBUG MODE

Specifies that this version of the trigger can be run in debugging mode. When ALLOW DEBUG MODE is in effect, a WLM environment must be available. If you do not specify WLM ENVIRONMENT FOR DEBUG MODE, Db2 uses the default WLM-established stored procedure address space specified at installation time.

DISALLOW DEBUG MODE

Specifies that this version of the trigger cannot be run in debugging mode. You can use an ALTER statement to change this option to ALLOW DEBUG MODE. When DISALLOW DEBUG MODE is in effect, a WLM environment must be available. If you do not specify WLM ENVIRONMENT FOR DEBUG MODE, Db2 uses the default WLM-established stored procedure address space specified at installation time.

DISABLE DEBUG MODE

Specifies that this version of the trigger can never be run in debugging mode.

This version of the trigger cannot be changed to specify ALLOW DEBUG MODE or DISALLOW DEBUG MODE after this version of the trigger has been created or altered to use DISABLE DEBUG MODE. To change this option, drop the trigger, and create it again using the option that you want. An alternative to dropping and recreating the trigger is to create a version of the trigger that uses the option that you want, and making that version the active version.

When DISABLE DEBUG MODE is in effect, the WLM ENVIRONMENT FOR DEBUG MODE is ignored.

QUALIFIER *schema-name*

Specifies the implicit qualifier that is used for unqualified object names that are referenced in the trigger body. For information about how the default for this option is determined, see [“Unqualified alias, index, JAR file, mask, permission, sequence, table, trigger, and view names” on page 86.](#)

ASUTIME

Specifies the total amount of processor time, in CPU service units, that a single invocation of this version of the trigger can run. The value is unrelated to the ASUTIME column of the resource limit specification table.

When you are debugging a trigger, setting a limit can be helpful in case the trigger gets caught in a loop. For information on service units, see [z/OS MVS Initialization and Tuning Guide.](#)

NO LIMIT

Specifies that there is no limit on the service units.

NO LIMIT is the default.

LIMIT *integer*

The limit on the number of CPU service units is a positive *integer* in the range 1–2147483647. If the trigger uses more service units than the specified value, Db2 cancels the trigger. The CPU cycles that are consumed by parallel tasks in a trigger do not contribute towards the specified ASUTIME LIMIT.

WLM ENVIRONMENT FOR DEBUG MODE *name*

Specifies the WLM (workload manager) application environment that is used by Db2 when debugging the trigger. The *name* of the WLM environment is an SQL identifier.

If you do not specify WLM ENVIRONMENT FOR DEBUG MODE, Db2 uses the default WLM-established stored procedure address space specified at installation time.

You must have the appropriate authority for the WLM application environment.

The WLM ENVIRONMENT FOR DEBUG MODE value is ignored when DISABLE DEBUG MODE is in effect.

CURRENT DATA YES or CURRENT DATA NO

Specifies whether to require data currency for read-only and ambiguous cursors when the isolation level of cursor stability is in effect. CURRENT DATA also determines whether block fetch can be used for distributed, ambiguous cursors.

CURRENT DATA YES

Specifies that data currency is required for read-only and ambiguous cursors. Db2 acquires page or row locks to ensure data currency. Block fetch is ignored for distributed, ambiguous cursors.

CURRENT DATA NO

Specifies that data currency is not required for read-only and ambiguous cursors. Block fetch is allowed for distributed, ambiguous cursors. Use of CURRENT DATA NO is not recommended if the trigger attempts to dynamically prepare and execute a DELETE WHERE CURRENT OF statement against an ambiguous cursor after that cursor is opened. You receive an error if your trigger attempts to use a DELETE WHERE CURRENT OF statement for any of the following cursors:

- A cursor that is using block fetch
- A cursor that is using query parallelism
- A cursor that is positioned on a row that is modified by this or another application process

CURRENT DATA NO is the default.

CONCURRENT ACCESS RESOLUTION

Specifies the whether processing uses only committed data or whether it will wait for commit or rollback of data that is in the process of being updated.

WAIT FOR OUTCOME

Specifies that processing will wait for the commit or rollback of data that is in the process of being updated.

USE CURRENTLY COMMITTED

Specifies that processing use the currently committed version of the data when data that is in the process of being updated is encountered. USE CURRENTLY COMMITTED is applicable on scans that access tables that are defined in universal table spaces with row or page level lock size.

When there is lock contention between a read transaction and an insert transaction, USE CURRENTLY COMMITTED is applicable to scans with isolation level CS or RS. Applicable scans include intent read scans for read-only and ambiguous queries and for updatable cursors. USE CURRENTLY COMMITTED is also applicable to scans initiated from WHERE predicates of UPDATE or DELETE statements and the subselect of INSERT statements.

When there is lock contention is between a read transaction and a delete transaction, USE CURRENTLY COMMITTED is applicable to scans with isolation level CS and when CURRENT DATA NO is specified.

DYNAMICRULES

Specifies the values that apply, at run time, for the following dynamic SQL attributes:

- The authorization ID that is used to check authorization
- The qualifier that is used for unqualified objects
- The source for application programming options that Db2 uses to parse and semantically verify dynamic SQL statements

In the context of a trigger, DYNAMICRULES also specifies whether dynamic SQL statements can include ALTER, CREATE, and DROP statements.

In addition to the value of the DYNAMICRULES clause, the run time environment of a trigger controls how dynamic SQL statements behave at run time. The combination of the DYNAMICRULES value and the run time environment determines the value for the dynamic SQL attributes. That set of attribute values is called the dynamic SQL statement behavior. The following values can be specified:

RUN

Specifies that dynamic SQL statements are to be processed using run behavior.

RUN is the default.

BIND

Specifies that dynamic SQL statements are to be processed using bind behavior.

See [“Authorization IDs and dynamic SQL” on page 94](#) for information on the effects of these options.

APPLICATION ENCODING SCHEME

Specifies the default encoding scheme for SQL variables in static SQL statements in the trigger body. The value is used for defining an SQL variable in a compound statement if the CCSID clause is not specified as part of the data type.

ASCII

Specifies that the data is encoded using the ASCII CCSIDs of the server.

EBCDIC

Specifies that the data is encoded using the EBCDIC CCSIDs of the server.

UNICODE

Specifies that the data is encoded using the Unicode CCSIDs of the server.

See [ENCODING bind option \(Db2 Commands\)](#) for information about how the default for this option is determined.

WITH EXPLAIN or WITHOUT EXPLAIN

Specifies whether information will be provided about how SQL statements in the trigger will execute.

WITHOUT EXPLAIN

Specifies that information will not be provided about how SQL statements in the trigger will execute.

You can get EXPLAIN output for a statement that is embedded in a trigger that is specified using WITHOUT EXPLAIN by embedding the SQL statement EXPLAIN in the trigger body. Otherwise, the value of the EXPLAIN option applies to all explainable SQL statements in the trigger body, and to the fullselect portion of any DECLARE CURSOR statements.

WITHOUT EXPLAIN is the default.

WITH EXPLAIN

Specifies that information will be provided about how SQL statements in the trigger will execute. Information is inserted into the table *owner.PLAN_TABLE*. *owner* is the authorization ID of the owner of the trigger. Alternatively, the authorization ID of the owner of the trigger can have an alias as *owner.PLAN_TABLE* that points to the base table, *PLAN_TABLE*. *owner* must also have the appropriate SELECT and INSERT privileges on that table. *PLAN_TABLE* must have a base table and can have multiple aliases with the same table name, *PLAN_TABLE*, but have different schema qualifiers. It cannot be a view or a synonym and should exist before the CREATE statement is processed. In all inserts to *owner.PLAN_TABLE*, the value of QUERYNO is the statement number that is assigned by Db2.

The WITH EXPLAIN option also populates two optional tables, if they exist: DSN_STATEMNT_TABLE and DSN_FUNCTION_TABLE. DSN_STATEMNT_TABLE contains an estimate of the processing cost for an SQL statement. See [Estimating the cost of SQL statements \(Db2 Performance\)](#) for more information. DSN_FUNCTION_TABLE contains information about function resolution. See [Checking how Db2 resolves functions by using DSN_FUNCTION_TABLE \(Db2 Application programming and SQL\)](#) for more information.

For more information about the EXPLAIN statement, including a description of the tables that are populated by the WITH EXPLAIN option, see [“EXPLAIN statement” on page 1917](#).

WITH IMMEDIATE WRITE or WITHOUT IMMEDIATE WRITE

Specifies whether immediate writes are to be done for updates that are made to group buffer pool dependent page sets or partitions. This option is only applicable for data sharing environments. The IMMEDWRITE subsystem parameter has no affect of this option. [IMMEDWRITE bind option \(Db2 Commands\)](#) shows the implied hierarchy of the IMMEDWRITE bind option (which is similar to this trigger option) as it affects run time.

WITHOUT IMMEDIATE WRITE

Specifies that normal write activity is performed. Updated pages that are group buffer pool dependent are written at or before phase one of commit or at the end of abort for transactions that have been rolled back.

WITHOUT IMMEDIATE WRITE is the default.

WITH IMMEDIATE WRITE

Specifies that updated pages that are group buffer pool dependent are immediately written as soon as the buffer update completes. Updated pages are written immediately even if the buffer is updated during forward progress or during the rollback of a transaction. WITH IMMEDIATE WRITE might impact performance.

ISOLATION LEVEL RR, RS, CS, or UR

Specifies how far to isolate the trigger from the effects of other running applications. For information about isolation levels, see [Choosing an ISOLATION option \(Db2 Performance\)](#).

RR

Specifies repeatable read.

RS

Specifies read stability.

CS

Specifies cursor stability. CS is the default.

UR

Specifies uncommitted read.

OPTHINT *string-constant*

Specifies whether query optimization hints are used for static SQL statements that are contained within the body of the trigger.

string-constant is a character string of up to 128 bytes in length, which is used by the Db2 subsystem when searching the PLAN_TABLE for rows to use as input. The default value is an empty string, which indicates that the Db2 subsystem does not use optimization hints for static SQL statements.

Optimization hints are only used if optimization hints are enabled for your system. See [Preparing to influence access paths \(Db2 Performance\)](#) for information about enabling optimization hints.

SQL PATH

Specifies the SQL path that Db2 uses to resolve unqualified user-defined types, functions, and procedure names in the body of the trigger. The default value is "SYSIBM", "SYSFUN", "SYSPROC", "SYSIBMADM", and the value of the QUALIFIER option.

Schemas "SYSIBM", "SYSFUN", "SYSPROC", "SYSIBMADM" do not need to be explicitly specified. If any of these schemas is not explicitly specified, it is implicitly assumed at the beginning the SQL path, in the order listed.

Db2 calculates the length by taking each *schema-name* specified and removing any trailing blanks from it, adding two delimiters around it, and adding one comma after each schema name, except for the last one. The length of the resulting string cannot exceed the length of the CURRENT_SCHEMA special register. If you do not specify the "SYSIBM", "SYSFUN", "SYSPROC", "SYSIBMADM", schemas, they are not included in the length of the SQL path. If the total length of the SQL path exceeds the length of the CURRENT_PATH special register, Db2 returns an error.

For more information, see:

[“SQL path” on page 85](#)

[“CURRENT_SCHEMA special register” on page 206](#)

[“CURRENT_PATH special register” on page 200](#)

schema-name

Identifies a schema. Db2 does not verify that the schema exists when the ALTER statement is processed. The same schema name should not appear more than once in the list of schema names.

SYSPUBLIC must not be specified for the SQL path.

SYSTEM PATH

Specifies the schema names "SYSIBM", "SYSFUN", "SYSPROC", "SYSIBMADM".

SESSION_USER or USER

Specifies the value of the SESSION_USER or USER special register, which represents a maximum 8-byte (in EBCDIC) *schema-name*. At the time the ALTER statement is processed, this length is included in the total length of the list of schema names that is specified for the SQL PATH option.

If you specify SESSION_USER (or USER) in a list of schema names, do not use delimiters around the SESSION_USER (or USER) keyword.

RELEASE AT

Specifies when to release resources that the trigger uses: either at each commit point or when the trigger terminates.

COMMIT

Specifies that resources will be released at each commit point.

COMMIT is the default.

DEALLOCATE

Specifies that resources will be released only when the thread terminates. DEALLOCATE has no effect on dynamic SQL statements, which always use RELEASE AT COMMIT, with this exception: When you use the RELEASE AT DEALLOCATE clause and the WITH KEEP DYNAMIC clause, and the subsystem is installed with a value of YES for the field CACHE DYNAMIC SQL on installation panel DSNTIP8, the RELEASE AT DEALLOCATE option is honored for dynamic SELECT and data change statements.

Locks that are acquired for dynamic statements are held until one of the following events occurs:

- The application process ends.
- The application process issues a PREPARE statement with the same statement identifier. (Locks are released at the next commit point).
- The statement is removed from the dynamic statement cache because the statement has not been used. (Locks are released at the next commit point.)
- An object that the statement is dependent on is dropped or altered, or a privilege that the statement needs is revoked. (Locks are released at the next commit point.)

RELEASE AT DEALLOCATE can increase the package or plan size because additional items become resident in the package or plan.

For more information, see [Choosing a RELEASE option \(Db2 Performance\)](#).

ROUNDING

Specifies the rounding mode for manipulation of DECFLOAT data. The default value is taken from the DEFAULT DECIMAL FLOATING POINT ROUNDING MODE in the application programming defaults module.

DEC_ROUND_CEILING

Specifies numbers are rounded towards positive infinity.

DEC_ROUND_DOWN

Specifies numbers are rounded towards 0 (truncation).

DEC_ROUND_FLOOR

Specifies numbers are rounded towards negative infinity.

DEC_ROUND_HALF_DOWN

Specifies numbers are rounded to nearest; if equidistant, round down.

DEC_ROUND_HALF_EVEN

Specifies numbers are rounded to nearest; if equidistant, round so that the final digit is even.

DEC_ROUND_HALF_UP

Specifies numbers are rounded to nearest; if equidistant, round up.

DEC_ROUND_UP

Specifies numbers are rounded away from 0.

DATE FORMAT ISO, EUR, USA, JIS, or LOCAL

Specifies the date format for result values that are string representations of date or time values. See [“String representations of datetime values” on page 120](#) for more information.

The default format is specified in the DATE FORMAT field of installation panel DSNTIP4 of the system where the routine is defined. You cannot use the LOCAL option unless you have a date exit routine.

DECIMAL(15), DECIMAL(31), DECIMAL(15,s), or DECIMAL(31,s)

Specifies the maximum precision that is to be used for decimal arithmetic operations. See [“Arithmetic with two decimal operands” on page 251](#) for more information. The default format is specified in the DECIMAL ARITHMETIC field of installation panel DSNTIPF of the system where the routine is defined. If the form *pp.s* is specified, *s* must be a number in the range 1–9. *s* represents the minimum scale that is to be used for division.

TIME FORMAT ISO, EUR, USA, JIS, or LOCAL

Specifies the time format for result values that are string representations of date or time values. See [“String representations of datetime values” on page 120](#) for more information.

The default format is specified in the TIME FORMAT field of installation panel DSNTIP4 of the system where the routine is defined. You cannot use the LOCAL option unless you have a date exit routine.

FOR UPDATE CLAUSE OPTIONAL or FOR UPDATE CLAUSE REQUIRED

Specifies whether the FOR UPDATE clause is required for a DECLARE CURSOR statement if the cursor is to be used to perform positioned updates.

FOR UPDATE CLAUSE REQUIRED

Specifies that a FOR UPDATE clause must be specified as part of the cursor definition if the cursor will be used to make positioned updates.

FOR UPDATE CLAUSE REQUIRED is the default.

FOR UPDATE CLAUSE OPTIONAL

Specifies that the FOR UPDATE clause does not need to be specified in order for a cursor to be used for positioned updates. The trigger body can include positioned UPDATE statements that update columns that the user is authorized to update.

The FOR UPDATE clause with no column list applies to static or dynamic SQL statements. Even if you do not use this clause, you can specify FOR UPDATE OF with a column list to restrict updates to only the columns that are identified in the FOR UPDATE clause and to specify the acquisition of update locks.

SECURED or NOT SECURED

Specifies that the trigger is to be changed to be secure or not secure. Changing a trigger between SECURED and NOT SECURED causes an implicit rebind of the trigger package. If an error is encountered during the implicit rebind of the trigger package, the ALTER TRIGGER statement returns the error.

SECURED

Specifies the trigger is considered secure.

SECURED must be specified for a trigger if its subject table is using row access control or column access control. SECURED must also be specified for a trigger that is created for a view and one or more of the underlying tables in the view definition is using row access control or column access control.

NOT SECURED

Specifies the trigger is considered not secure.

NOT SECURED must not be specified for a trigger whose subject table is using row access control or column access control. NOT SECURED must also not be specified for a trigger that is created for a view and one or more of the underlying tables in the view definition is using row access control or column access control.

BUSINESS_TIME SENSITIVE

Determines whether references to application-period temporal tables in both static and dynamic SQL statements are affected by the value of the CURRENT TEMPORAL BUSINESS_TIME special register.

YES

References to application-period temporal tables are affected by the value of the CURRENT TEMPORAL BUSINESS_TIME special register. YES is the default value.

NO

References to application-period temporal tables are not affected by the value of the CURRENT TEMPORAL BUSINESS_TIME special register.

For more information, see [“CURRENT TEMPORAL BUSINESS_TIME special register”](#) on page 208.

SYSTEM_TIME SENSITIVE

Determines whether references to system-period temporal tables in both static and dynamic SQL statements are affected by the value of the CURRENT TEMPORAL SYSTEM_TIME special register.

YES

References to system-period temporal tables are affected by the value of the CURRENT TEMPORAL SYSTEM_TIME special register. YES is the default value.

NO

References to system-period temporal tables are not affected by the value of the CURRENT TEMPORAL SYSTEM_TIME special register.

For more information, see [“CURRENT TEMPORAL SYSTEM_TIME special register”](#) on page 210.

ARCHIVE SENSITIVE

Determines whether references to archive-enabled tables in SQL statements are affected by the value of the SYSIBMADM.GET_ARCHIVE built-in global variable.

YES

References to archive-enabled tables are affected by the value of the SYSIBMADM.GET_ARCHIVE built-in global variable. YES is the default value.

NO

References to archive-enabled tables are not affected by the value of the SYSIBMADM.GET_ARCHIVE built-in global variable.

For related information, see [“GET_ARCHIVE”](#) on page 330.

APPLCOMPAT

Specifies the application compatibility level behavior for static SQL statements in the trigger body. The following Db2 function level values can be specified:

VvvRrMmmm

Compatibility with the behavior of the identified Db2 function level. For example, V12R1M510 specifies compatibility with the highest available Db2 12 function level. The equivalent function level or higher must be activated.

For the new capabilities that become available in each application compatibility level, see:

- [SQL changes in Db2 13 application compatibility levels](#)
- [SQL changes in Db2 12 application compatibility levels](#)

Tip: Extra program preparation steps might be required to increase the application compatibility level for applications that use data server clients or drivers to access Db2 for z/OS. For more information, see [Setting application compatibility levels for data server clients and drivers \(Db2 Application programming and SQL\)](#).

V12R1

Compatibility with the behavior of Db2 12 function level 500. This value has the same result as specifying V12R1M500.

Values such as V11R1 and V10R1 for compatibility with previous Db2 releases are not supported for triggers.

CONCENTRATE STATEMENTS OFF or CONCENTRATE STATEMENTS WITH LITERALS

Specifies whether a dynamic SQL statement that specifies literal constants will be cached as a separate unique statement entry in the dynamic statement cache instead of sharing an existing statement in the cache. Dynamic SQL statements are eligible to share an existing statement in the cache if the new statement meets all of the conditions for sharing a cached version of the same dynamic statement except that the new statement specifies one or more literal constants that are different than the cached statement.

CONCENTRATE STATEMENTS OFF

Specifies that the dynamic SQL statement that specifies literal constants will be cached as a unique statement entry if it specifies one or more constants that are different than the cached version of the same dynamic statement. CONCENTRATE STATEMENTS OFF is the default dynamic statement caching behavior.

CONCENTRATE STATEMENTS WITH LITERALS

Specifies that the dynamic SQL statement that specifies literal constants will share a cached version of the same dynamic statement that is also prepared using the CONCENTRATE STATEMENTS WITH LITERALS option if the new dynamic statement meets all of the conditions for sharing the cached statement and the constants that are specified can be reused in place of the constants in the cached statement.

triggered-action

Specifies the action to be performed when the trigger is activated. The *triggered-action* is composed of one or more SQL statements and an optional condition that controls whether the statements are executed.

WHEN (*search-condition*)

Specifies a condition that evaluates to true, false, or unknown. The triggered SQL statements are executed only if the *search-condition* evaluates to true. If the WHEN clause is omitted, the associated SQL statements are always executed.

The WHEN clause must not be specified for an INSTEAD OF trigger.

SQL-trigger-body

Specifies a single *SQL-control-statement*, including a compound statement, or *triggered-SQL-statement* that is to be executed for the *triggered-action*. See Chapter 8, “SQL procedural language (SQL PL),” on page 2207 for more information about defining SQL triggers.

SQL-control-statement

Specifies an SQL control statement, which can include nested control statements and other SQL statements specified in the syntax diagram for “*SQL-procedure-statement (SQL PL)*” on page 2212. The statements that can be specified for *SQL-procedure-statement* are subject to the syntax notes relating to triggers.

triggered-SQL-statement

Specifies an SQL statement that is the only statement in a trigger body.

Only certain SQL statements can be specified in the *SQL-trigger-body*.

The trigger body must not contain a statement that is not supported.

- A statement in the trigger body must not refer to host variables, undefined transition variables, or declared temporary tables.
- A statement in the trigger body must only refer to a table or view that is at the current server.
- A statement in the trigger body must only invoke a stored procedure or user-defined function that is at the current server. An invoked routine can, however, access a server other than the current server.

- A statement in the trigger body must not modify a column that is part of a BUSINESS_TIME period.
- The trigger body must not, directly or indirectly, issue a CALL statement for a procedure that contains one of the following statements:
 - COMMIT
 - CONNECT
 - RELEASE *connection*
 - RELEASE SAVEPOINT
 - ROLLBACK (without TO SAVEPOINT)
 - SAVEPOINT
 - SET CONNECTION
- The trigger body must not, directly or indirectly, issue a CALL statement for a procedure that is defined with the COMMIT ON RETURN option.
- If the trigger is a before trigger:
 - The trigger body must not contain a DELETE, INSERT, MERGE, REFRESH TABLE, TRUNCATE, UPDATE statement, or SELECT FROM *data-change-statement*.
 - The trigger body must not, directly or indirectly, invoke a routine containing one of the following statements:
 - ALTER
 - COMMENT
 - CREATE
 - DECLARE GLOBAL TEMPORARY TABLE
 - DELETE
 - DROP
 - EXCHANGE
 - GRANT
 - INSERT
 - LABEL
 - LOCK TABLE
 - MERGE
 - REFRESH TABLE
 - RENAME
 - REVOKE
 - TRUNCATE
 - UPDATE

A CREATE TRIGGER statement (or ALTER TRIGGER statement) cannot contain a hexadecimal graphic string (GX) constant.

The triggered action can refer to the values in the set of affected rows. This action is supported through the use of transition variables and transition tables.

All tables, views, aliases, sequences, roles, user-defined data types, user-defined functions, and procedures referenced in the *triggered-action* must exist at the current server when the trigger is created, or the version of the trigger is defined. The table or view that an alias refers to must also exist when the trigger is created, or the version of the trigger is defined.

Notes for ALTER TRIGGER (advanced)

Changing to an advanced trigger:

You cannot use an ALTER TRIGGER statement to change a basic trigger into an advanced trigger. You can drop the existing trigger you want to change using the DROP statement and then create an advanced trigger with a similar definition using the CREATE TRIGGER statement in Db2 12 with new function activated, or you can use the CREATE TRIGGER statement with the OR REPLACE clause. Alternatively, you can create an advanced trigger using a different schema. To define an advanced trigger, omit the MODE DB2SQL clause in the CREATE TRIGGER statement.

Changes are immediate:

Any changes that the ALTER TRIGGER statement causes to the definition of a trigger take effect immediately. The changed definition is used the next time that the trigger is activated.

Identifier resolution:

See Chapter 8, “SQL procedural language (SQL PL),” on page 2207 for information on how names are resolved to columns, SQL variables, transition variables, or global variables within a trigger body.

If non-unique names are used for columns, SQL variables, transition variables, or global variables, qualify the non-unique names by using the table designator for columns, the label name for SQL variables, correlation name for transition variables, and schema for global variables.

Transition variables and transition tables:

The triggered action can refer to the values in the set of affected rows. This action is supported through the use of transition variables and transition tables.

A transition variable has the same name and data type as the corresponding column of the table that the trigger is defined on, and is nullable. A transition variable contains the value of a column in an affected row. A transition variable is qualified by a correlation name that identifies whether the reference is to the old value (before the update) or the new value (after the update). A transition variable can be referenced in the search condition, or in an SQL statement in the trigger body wherever a table would be allowed if the reference was made outside the body of a trigger. A new transition variable can be assigned a value in a before update or insert trigger. The values of the updated rows include the changes from any assignments to transition variables in the triggered action of a before trigger.

A transition table contains the complete set of affected rows with either the old values (before the update) or the new values (after the update). Transition tables are read only and can be referenced in the triggered action of an after or instead of trigger. Transition tables also use the name of columns of the subject table but have an associated table identifier that allows the complete set of affected rows to be treated as a table. Separate table identifiers can be specified for the old and new transition tables. Transition tables can be referenced in the triggered action in a search condition, or in an SQL statement in the trigger body wherever a variable would be allowed if the reference was made outside the body of a trigger. In addition, a transition table can be passed as an argument to a user-defined function or procedure specifying the TABLE keyword before the table identifier for the transition table. When the function or procedure is invoked, a table locator is passed for the transition table.

Altering a trigger from NOT SECURED to SECURED:

Typically, the security administrator will examine the data that is accessed by a trigger, ensure that it is secure, and grant the CREATE_SECURE_OBJECT privilege to the owner of the trigger. After the trigger is changed to SECURED, the security administrator will revoke the CREATE_SECURE_OBJECT privilege from the owner of the trigger.

The trigger is considered secure after the ALTER TRIGGER statement is executed. Db2 treats the SECURED attribute as an assertion that declares that the user has established an audit procedure for all activities in the trigger body. If a secure trigger references user-defined functions, Db2 assumes those functions are secure without validation. If those functions can access sensitive data, the user with SECADM authority needs to ensure that those functions are allowed to access that data and that an audit procedure is in place for all versions of those functions, and that all subsequent ALTER FUNCTION statements or changes to external packages are being reviewed by this audit process.

A trigger must be secure if its subject table is using row access control or column access control. SECURED must also be specified for a trigger that is created for a view and one or more of the underlying tables in the view definition is using row access control or column access control.

Altering a trigger from SECURED to NOT SECURED:

The ALTER TRIGGER statement returns an error if the subject table of the trigger is using row access control or column access control, or if the trigger is for a view and one or more of the underlying tables in the view definition is using row access control or column access control.

Altering obfuscated triggers:

Obfuscated triggers cannot be altered in any way.

Row access control and column access control that is not enforced for transition variables and transition tables:

If row access control or column access control is enforced for the subject table of the trigger, row permissions and column masks are not applied to the initial values of transition variables and transition tables. Row access control and column access control is enforced for the triggering table, but is ignored for transition variables and transition tables that are referenced in the body of the trigger body or are passed as arguments to user-defined functions that are invoked in the body of the trigger. To ensure that there are no security concerns for SQL statements accessing sensitive data in transition variables and transition tables in the trigger action, the trigger must be changed to use the SECURED option. If a trigger is not secure, row access control and column access control cannot be enforced for the triggering table.

Correspondence of trigger options to bind options

The following table lists options for CREATE TRIGGER and ALTER TRIGGER, and the corresponding options for the bind commands. See BIND and REBIND options for packages, plans, and services (Db2 Commands) for more information about the effects of the bind options.

Table 191. Correspondence of trigger options to bind options

CREATE TRIGGER (advanced) or ALTER TRIGGER (advanced) option	bind commands option
APPLCOMPAT	APPLCOMPAT(V12R1)
APPLICATION ENCODING SCHEME	ENCODING(ASCII) ENCODING(EBCDIC) ENCODING(UNICODE)
ARCHIVE SENSITIVE	ARCHIVESENSITIVE(YES) ARCHIVESENSITIVE(NO)
BUSINESS_TIME SENSITIVE	BUSTIMESENSITIVE(YES) BUSTIMESENSITIVE(NO)
CURRENT DATA	CURRENTDATA(NO) CURRENTDATA(YES)
CONCENTRATE STATEMENTS OFF CONCENTRATE STATEMENTS WITH LITERALS	CONCENTRATESTMT(NO) CONCENTRATESTMT(YES)
CONCURRENT ACCESS RESOLUTION	CONCURRENTACCESSRESOLUTION (USECURRENTLYCOMMITTED) CONCURRENTACCESSRESOLUTION (WAITFOROUTCOME)
DYNAMICRULES	DYNAMICRULES(BIND) DYNAMICRULES(RUN)

Table 191. Correspondence of trigger options to bind options (continued)

CREATE TRIGGER (advanced) or ALTER TRIGGER (advanced) option	bind commands option
ISOLATION LEVEL	ISOLATION(RR) ISOLATION(RS) ISOLATION(CS) ISOLATION(UR)
OPTHINT	OPTHINT
QUALIFIER	QUALIFIER
RELEASE	RELEASE(COMMIT) RELEASE(DEALLOCATE)
ROUNDING	ROUNDING(CEILING) ROUNDING(DOWN) ROUNDING(FLOOR) ROUNDING(HALFDOWN) ROUNDING(HALFEVEN) ROUNDING(HALFUP) ROUNDING(UP)
SQL PATH	PATH
SYSTEM_TIME SENSITIVE	SYSTEMTIMESENSITIVE(YES) SYSTEMTIMESENSITIVE(NO)
WITH OR WITHOUT EXPLAIN	EXPLAIN(YES) EXPLAIN(NO)
WITH OR WITHOUT IMMEDIATE WRITE	IMMEDWRITE(YES) IMMEDWRITE(NO)

Considerations for packages:

When certain attributes of a trigger are changed, the body of the trigger might be rebound or regenerated. However, there is no impact to existing packages that might cause the activation of the trigger, and such packages are not invalidated. No additional bind-related privileges are required for an implicit rebound or regeneration of the trigger body.

If an error is encountered during an implicit rebound, the ALTER TRIGGER statement fails and returns the error.

When execution of a package causes the activation of the trigger, the rebound or regenerated trigger package executes.

Table 192 on page 1363 summarizes when implicit rebound and regeneration occurs when specific options are changed. A value of Y in a row indicates that a rebound or regeneration will occur if the option is changed for a trigger.

Table 192. ALTER TRIGGER (advanced) options that result in rebind or regeneration when changed

ALTER TRIGGER (advanced) option	Change results in implicit rebind of the non-control statements of the body of the trigger ?	Change results in implicit regeneration of the entire body of the trigger ?
ALLOW DEBUG MODE, DISALLOW DEBUG MODE, or DISABLE DEBUG MODE	Y ²	Y
APPLCOMPAT	N	N
APPLICATION ENCODING SCHEME	Y	Y
ARCHIVE SENSITIVE YES or NO	Y	Y
ASUTIME	N	N
BUSINESS_TIME SENSITIVE YES or NO	Y	Y
CONCENTRATE STATEMENTS OFF or WITH LITERALS	Y	N
CONCURRENT ACCESS RESOLUTION	Y	N
CURRENT DATA	Y	N
DATE FORMAT	Y	Y
DECIMAL	Y	Y
DYNAMICRULES BIND OR RUN	Y	N
FOR UPDATE CLAUSE OPTIONAL or FOR UPDATE CLAUSE REQUIRED	Y	N
ISOLATION LEVEL	Y	N
OPTHINT	Y	N
QUALIFIER	Y	N
RELEASE	Y	N
ROUNDING	Y	Y
SECURED OR NOT SECURED	Y	N
SQL PATH	Y	Y
SYSTEM_TIME SENSITIVE	Y	Y
TIME FORMAT	Y	Y
WITH EXPLAIN OR WITHOUT EXPLAIN	Y	N
WITH IMMEDIATE WRITE OR WITHOUT IMMEDIATE WRITE	Y	N
WLM ENVIRONMENT FOR DEBUG MODE	N	N

Note:

1. When an implicit rebind of the non-control statements in the body of the trigger occurs, the QUALIFIER and SQL PATH options are not re-evaluated.
2. The trigger package is rebound and regenerated if a value of ALLOW DEBUG MODE is changed to DISALLOW DEBUG MODE.

Application compatibility level considerations for trigger objects

The application compatibility level controls the adoption and use of new capabilities and enhancements. When an object is created or altered, two separate application compatibility levels are used: one to process the definition of the object, and the other for processing the SQL statements in the object body:

Object definition	<p>The CURRENT APPLICATION COMPATIBILITY special register value is used to process the object definition, except for statements in the object body</p> <p>This application compatibility level is stored in the SYSENVIRONMENT.APPLCOMPAT column. You can use the environment ID value in the catalog definition of the object to locate the SYSENVIRONMENT row with the matching ENVID value.</p> <p>This application compatibility level can be changed when the object is regenerated.</p>
Statements in the object body	<p>The application compatibility level that is implicitly or explicitly specified with the APPLCOMPAT option of the CREATE or ALTER statement is used to process statements in the object body.</p> <p>This application compatibility level is stored in the SYSPACKAGE.APPLCOMPAT column for the package associated with the object definition.</p>

Altering a trigger definition using a lower application compatibility level than the current definition

If the CURRENT APPLICATION COMPATIBILITY special register value is lower than the application compatibility level of the existing object definition, altering an object might result in an error even if the content of the ALTER statement is valid at the current level. The errors can occur when the existing object definition contains some functionality that requires a higher level than the CURRENT APPLICATION COMPATIBILITY special register setting.

Application compatibility levels for regenerating trigger objects

For ALTER statements that regenerate objects, the object definition is reprocessed using the application compatibility setting that is specified implicitly or explicitly by the USING APPLICATION COMPATIBILITY clause that follows the REGENERATE keyword. This application compatibility value replaces the existing value in the SYSENVIRONMENT.APPLCOMPAT column for the environment settings associated with the object definition.

If the USING APPLICATION COMPATIBILITY clause is not specified, the existing application compatibility value in the SYSENVIRONMENT.APPLCOMPAT column for the object definition is used to reprocess the text associated with the object definition.

The behavior of the statements in the body remains controlled by the value the existing APPLCOMPAT option of the object.

Considerations for the SYSENVIRONMENTS catalog table:

An ALTER statement that specifies new environment settings will result in a new row being added to the SYSENVIRONMENTS catalog table. The new row will be added even if an error is subsequently encountered during processing of the ALTER statement. Thus, a new SYSENVIRONMENTS row might be added even for an ALTER statement that fails.

Dependent objects:

A trigger is dependent on the triggering table and objects that are referenced in the trigger body.

Error handling in triggers:

A trigger can return errors like other SQL statements. Applications should be aware of the possible errors that can be expected when a trigger is invoked. Any exception SQLSTATE that is not handled within the trigger body (using a handler), results in the exception SQLSTATE being returned to the statement that caused the trigger to be activated. For example, if a SIGNAL statement (RESIGNAL

statement or RAISE_ERROR function) raises a non-severe error in the *SQL-trigger-body* and the condition is not handled within the trigger body, SQLCODE -438 and the specified SQLSTATE will be returned. Other non-severe errors are returned with SQLCODE -723 and SQLSTATE 09000. Severe errors that occur during the execution of triggered SQL statements are returned with SQLCODE -901, -906, -911, and -913 and the corresponding SQLSTATE. Warnings are not returned.

Examples for ALTER TRIGGER (advanced)

Example 1: Change the definition of trigger TRIGGER1 to secured

```
ALTER TRIGGER TRIGGER1
SECURED;
```

Example 2: Alter the definition of trigger TRIGGER1 to allow it to be run in debugging mode

```
ALTER TRIGGER TRIGGER1
ALTER ALLOW DEBUG MODE;
```

Example 3: Use the ACTIVATE VERSION clause to make a new version of the trigger the currently active version

```
ALTER TRIGGER TRIGGER1
ACTIVATE VERSION V3;
```

Example 4: Regenerate the currently active version of a trigger

```
ALTER TRIGGER TRIGGER1
REGENERATE ACTIVE VERSION;
```

ALTER TRIGGER statement (basic trigger)

The ALTER TRIGGER (basic) statement changes the description of a basic trigger at the current server. For a description of the differences between basic and advanced triggers, see [Triggers \(Introduction to Db2 for z/OS\)](#).

Invocation for ALTER TRIGGER (basic)

This statement can be embedded in an application program or issued interactively. It is an executable statement that can be dynamically prepared only if DYNAMICRULES RUN behavior is in effect. For more information, see [“Authorization IDs and dynamic SQL”](#) on page 94.

Authorization for ALTER TRIGGER (basic)

The privilege set that is defined below must include at least one of the following:

- Ownership of the trigger
- The ALTERIN privilege on the schema
- SYSADM authority
- SYSCTRL authority
- System DBADM
- Installation SYSOPR authority (when the current SQLID of the process is set to SYSINSTL)

The authorization ID that matches the schema name implicitly has the ALTERIN privilege on the schema.

Privilege set: If the statement is embedded in an application program, the privilege set is the set of privileges that are held by the owner of the plan or package. If the statement is dynamically prepared, the privilege set is the set of privileges that are held by the SQL authorization ID of the process. The specified

trigger name can include a schema name (a qualifier). However, if the schema name is not the same as one of the authorization ID of the process, one of the following conditions must be met:

- The privilege set includes SYSADM authority, SYSCTRL authority, or system DBADM authority.
- The authorization ID of the process has the ALTERIN privilege on the schema.

If the SECURED option is specified, at least one of the following privileges is required:

- SECADM authority
- CREATE_SECURE_OBJECT privilege

Note: If the SEPARATE SECURITY subsystem parameter is set to NO, SYSADM authority has implicit SECADM authority.

Syntax for ALTER TRIGGER (basic)

```
▶ ALTER TRIGGER — trigger-name — option-list ▶
```

option-list:

```
▶ NOT SECURED ▶  
└── SECURED ─┘
```

Description for ALTER TRIGGER (basic)

trigger-name

Identifies the trigger that is to be changed. The name, including the implicit or explicit schema name, must exist at the current server. The name must identify a basic trigger.

The trigger must not be obfuscated.

SECURED or NOT SECURED

Specifies that the trigger is to be changed to be secure or not secure. Changing a trigger between SECURED and NOT SECURED causes an implicit rebind of the trigger package. If an error is encountered during the implicit rebind of the trigger package, the ALTER TRIGGER statement returns the error.

SECURED

Specifies the trigger is considered secure.

SECURED must be specified for a trigger if its subject table is using row access control or column access control. SECURED must also be specified for a trigger that is created for a view and one or more of the underlying tables in the view definition is using row access control or column access control.

NOT SECURED

Specifies the trigger is considered not secure.

NOT SECURED must not be specified for a trigger whose subject table is using row access control or column access control. NOT SECURED must also not be specified for a trigger that is created for a view and one or more of the underlying tables in the view definition is using row access control or column access control.

Notes for ALTER TRIGGER (basic)

Changing an existing trigger into an advanced trigger:

To change a basic trigger or a trigger defined prior to Db2 12 with new function activated into an advanced trigger, use one of the following methods:

- issue a DROP TRIGGER statement followed by a CREATE TRIGGER (advanced) statement, specifying the desired definition of the advanced trigger to redefine it. The existing trigger is effectively dropped, and a new advanced trigger is defined. This affects the trigger activation order for the table on which the trigger is defined.
- issue a CREATE TRIGGER (advanced) statement with the OR REPLACE clause, and specify the desired definition of the advanced trigger. The existing trigger is effectively dropped, and a new advanced trigger is defined. This affects the trigger activation order for the table on which the trigger is defined.

Changes are immediate:

Any changes that the ALTER TRIGGER statement causes to the definition of a trigger take effect immediately. The changed definition is used the next time that the trigger is activated.

Altering a trigger from NOT SECURED to SECURED:

Typically, the security administrator will examine the data that is accessed by a trigger, ensure that it is secure, and grant the CREATE_SECURE_OBJECT privilege to the owner of the trigger. After the trigger is changed to SECURED, the security administrator will revoke the CREATE_SECURE_OBJECT privilege from the owner of the trigger.

The trigger is considered secure after the ALTER TRIGGER statement is executed. Db2 treats the SECURED attribute as an assertion that declares that the user has established an audit procedure for all activities in the trigger body. If a secure trigger references user-defined functions, Db2 assumes those functions are secure without validation. If those functions can access sensitive data, the user with SECADM authority needs to ensure that those functions are allowed to access that data and that an audit procedure is in place for all versions of those functions, and that all subsequent ALTER FUNCTION statements or changes to external packages are being reviewed by this audit process.

A trigger must be secure if its subject table is using row access control or column access control. SECURED must also be specified for a trigger that is created for a view and one or more of the underlying tables in the view definition is using row access control or column access control.

Altering a trigger from SECURED to NOT SECURED:

The ALTER TRIGGER statement returns an error if the subject table of the trigger is using row access control or column access control, or if the trigger is for a view and one or more of the underlying tables in the view definition is using row access control or column access control.

Altering obfuscated triggers:

Obfuscated triggers cannot be altered in any way.

Row access control and column access control that is not enforced for transition variables and transition tables:

If row access control or column access control is enforced for the subject table of the trigger, row permissions and column masks are not applied to the initial values of transition variables and transition tables. Row access control and column access control is enforced for the triggering table, but is ignored for transition variables and transition tables that are referenced in the body of the trigger body or are passed as arguments to user-defined functions that are invoked in the body of the trigger. To ensure that there are no security concerns for SQL statements accessing sensitive data in transition variables and transition tables in the trigger action, the trigger must be changed to use the SECURED option. If a trigger is not secure, row access control and column access control cannot be enforced for the triggering table.

Examples for ALTER TRIGGER (basic)

Example 1: Change the definition of trigger TRIGGER1 to secured:

```
ALTER TRIGGER TRIGGER1
SECURED;
```

ALTER TRUSTED CONTEXT statement

The ALTER TRUSTED CONTEXT statement modifies the definition of a trusted context at the current server.

Invocation for ALTER TRUSTED CONTEXT

This statement can be embedded in an application program or issued interactively. It is an executable statement that can be dynamically prepared only if DYNAMICRULES RUN behavior is in effect. For more information, see [“Authorization IDs and dynamic SQL” on page 94](#).

Authorization for ALTER TRUSTED CONTEXT

The privilege set that is defined below must include at least one of the following:

- SYSADM authority
- SECADM authority

Privilege set: If the statement is embedded in an application program, the privilege set is the set of privileges that are held by the owner of the plan or package.

If the statement is dynamically prepared, the privilege set is the union of the set of privileges that are held by each authorization ID of the process. If the statement is run in a trusted context with a role, the privilege set is the union of the set of privileges that are held by the role that is associated with the primary authorization ID and the set of privileges that are held by each authorization ID of the process.

Syntax for ALTER TRUSTED CONTEXT

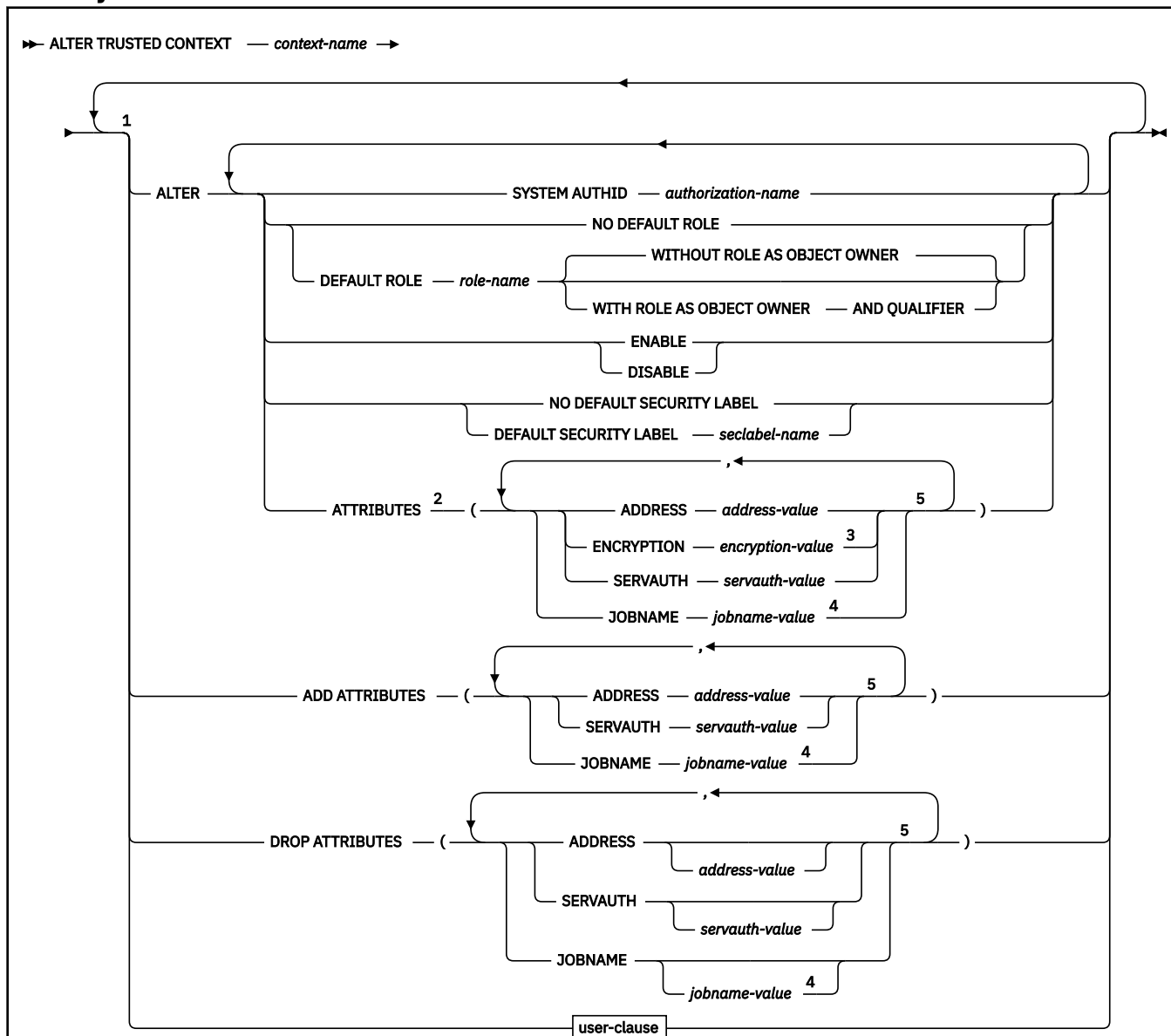

Notes:

- 1 These clauses can be specified in any order. Each clause must not be specified more than one time.
- 2 This clause and the clauses that follow can be specified in any order. Each clause must not be specified more than one time.
- 3 ENCRYPTION must not be specified more than one time.
- 4 JOBNAME must not be specified with ADDRESS, ENCRYPTION, or SERVAUTH.
- 5 Each pair of attribute name and corresponding value must be unique.

user-clause:

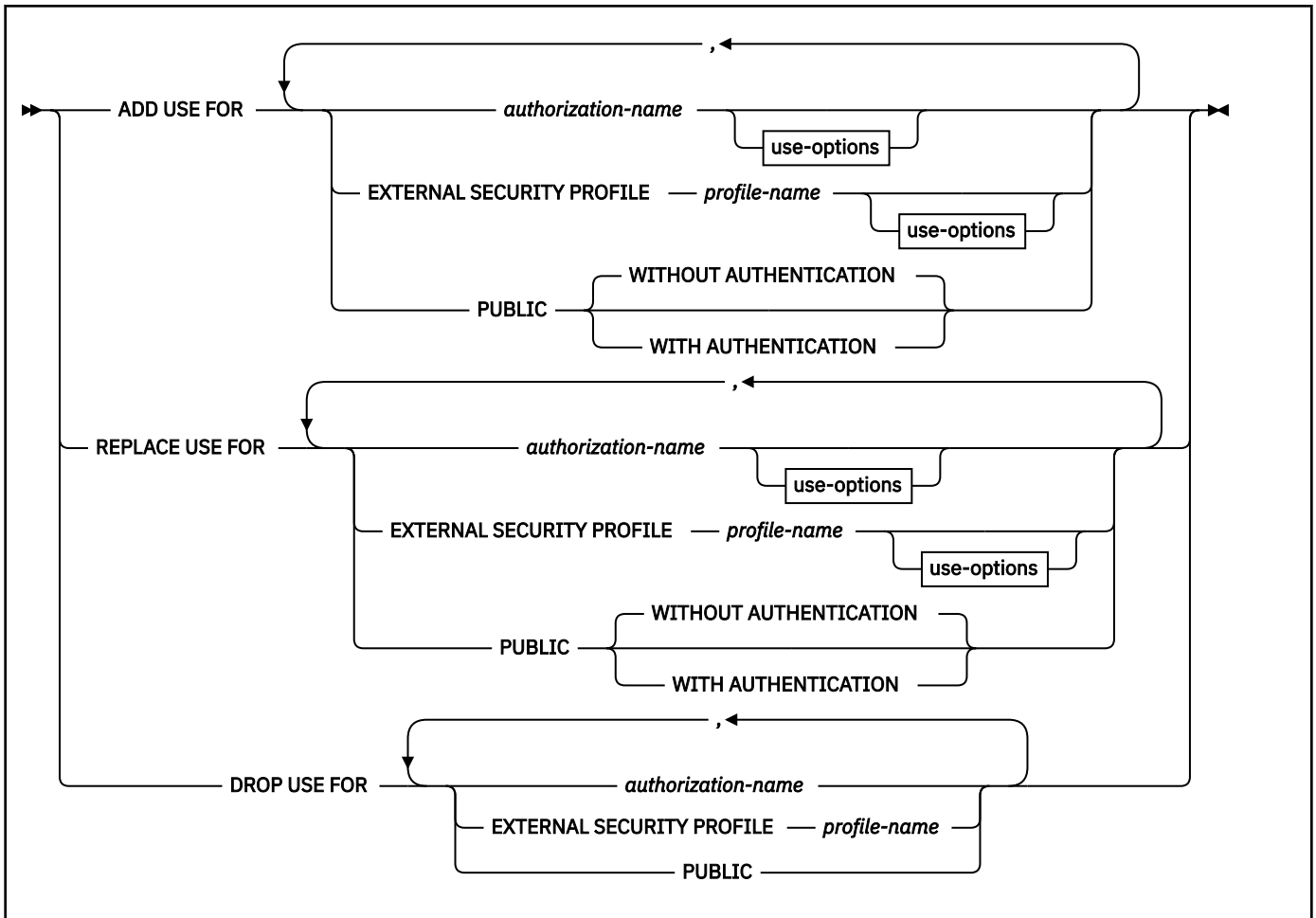

use-options:

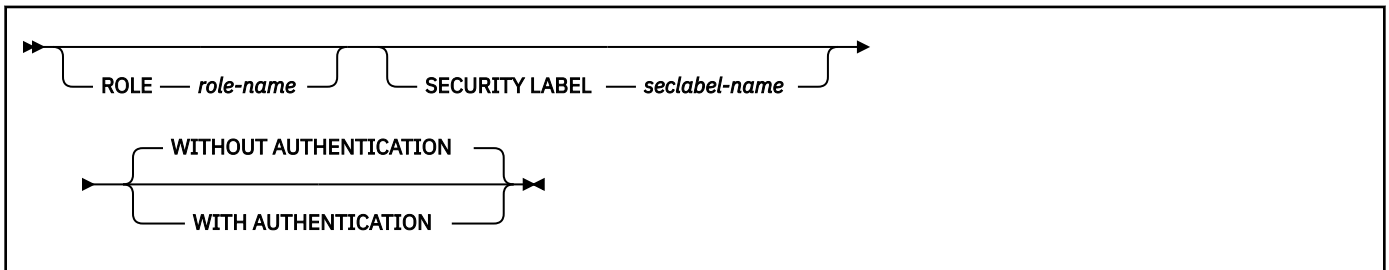

Description for ALTER TRUSTED CONTEXT

context-name

Identifies the trusted context to alter. *context-name* must refer to a trusted context that exists at the current server.

ALTER

Specifies that changes are to be made to the definition of an existing trusted context.

SYSTEM AUTHID authorization-name

Specifies that *authorization-name* is the system authorization ID for the trusted context. The system authorization ID is the primary authorization ID of the Db2 system that establishes the connection. For a remote connection, the authorization ID is derived from the system used ID that is provided by the external entity, such as a middleware server. For a local connection, the system authorization ID is derived depending on the sources, as specified in [Table 193 on page 1371](#).

Table 193. System authorization ID for a local connection

Source of local connection	System authorization ID
Started task (RRSAF)	USER parameter on JOB statement or RACF USER.
TSO	TSO logon ID
BATCH	USER parameter on JOB statement

authorization-name must not be associated with an existing trusted context.

NO DEFAULT ROLE or DEFAULT ROLE *role-name*

Specifies whether a default role is associated with a trusted connection that is based on the specified trusted context. If a trusted connection for the specified context is active, the change goes into effect at the next connection reuse attempt or when a new connection is requested.

NO DEFAULT ROLE

Specifies that the trusted context does not have a default role. The authorization ID of the process is the owner of any object that is created using a trusted connection that is based on this trusted context. That authorization ID must possess all of the privileges that are necessary to create that object.

DEFAULT ROLE *role-name*

Specifies that *role-name* is the role for the trusted context. *role-name* must identify a role that exists at the current server. This role is used with the user in a trusted connection that is based on the specified trusted context when the user does not have a user-specified role that is defined as part of the definition of this trusted context.

WITHOUT ROLE AS OBJECT OWNER or WITH ROLE AS OBJECT OWNER AND QUALIFIER

Specifies whether a role is used as the owner of objects that are created using a trusted connection that is based on the specified trusted context. If a trusted connection for the specified context is active, the change goes into effect at the next connection reuse attempt or when a new connection is requested.

WITHOUT ROLE AS OBJECT OWNER

Specifies that a role is not used as the owner of the objects that are created using a trusted connection that is based on the specified trusted context. The authorization ID of the process is the owner of any object that is created using a trusted connection that is based on this trusted context. That authorization ID must possess all of the privileges that are necessary to create the object.

WITHOUT ROLE AS OBJECT OWNER is the default.

WITH ROLE AS OBJECT OWNER AND QUALIFIER

Specifies that the context assigned role is the owner of the objects that are created using a trusted connection that is based on this trusted context. That role must possess all of the privileges that are necessary to create the object. The context assigned role is the role that is defined for the user within this trusted context, if one is defined. Otherwise, the role is the default role that is associated with the trusted context. The role is also used as the grantor for any GRANT statements that are issued, and the revoker for any REVOKE statement that are issued using a trusted connection that is based on this trusted context.

AND QUALIFIER

Specifies that the *role-name* will be used as the default for the CURRENT SCHEMA special register. The *role-name* will also be included in the SQL PATH (in place of CURRENT SQLID).

When WITH ROLE AS OBJECT OWNER AND QUALIFIER is not specified, there is no change to the default of the CURRENT SCHEMA special register and SQL PATH.

DISABLE or ENABLE

Specifies whether the trusted context is in the enabled or disabled state.

DISABLE

Specified that the trusted context is disabled. A trusted context that is disabled is not considered when a trusted connection is established.

ENABLE

Specifies that the trusted context is enabled.

NO DEFAULT SECURITY LABEL or DEFAULT SECURITY LABEL *seclabel-name*

Specifies whether a default security label is associated with a trusted connection that is based on this trusted context. If a trusted connection for the specified context is active, the change goes into effect at the next connection reuse attempt or when a new connection is requested.

NO DEFAULT SECURITY LABEL

Specifies that the trusted context does not have a default security label.

DEFAULT SECURITY LABEL *seclabel-name*

Specifies that *seclabel-name* is the default security label for the trusted context. *seclabel-name* is the security label that is used for multilevel security verification. *seclabel-name* must identify one of the RACF SECLABEL values that is defined for the SYSTEM AUTHID. This security label is used in a trusted connection that is based on the specified trusted context when the user does not have a specific security label defined as part of the definition of this trusted context. In this case, *seclabel-name* must also identify one of the RACF SECLABEL values that is defined for the user.

ALTER ATTRIBUTES or ADD ATTRIBUTES

Specifies a list of one or more connection trust attributes to change or add to the definition of a trusted context. The connection trust attributes are used to define the trusted context. If ALTER ATTRIBUTES is specified and the attribute is not currently part of the definition of the specified trusted context, an error is returned. Existing specifications for the specified attributes are changed to the new value if ALTER is specified. Attributes that are not specified retain the previously specified values.

ADDRESS *address-value*

Specifies the actual communication address that is used by the connection to communicate with the database manager. The protocol supported is only for TCP/IP. Previously specified ADDRESS values are removed when ALTER ATTRIBUTES is specified. The ADDRESS attribute can be specified multiple times, but each *address-value* must be unique.

When establishing a trusted connection, if multiple values are defined for the ADDRESS attribute for a trusted context, a candidate connection is considered to match this attribute if the address that is used by a connection matches any of the values that are defined for the ADDRESS attribute of the trusted context.

address-value specifies a string constant that contains the value that is associated with the ADDRESS trust attribute. *address-value* must be an IPv4 address, an IPv6 address, or a secure domain name with a length no greater than 254 bytes. No validation of *address-value* is done at the time the ALTER TRUSTED CONTEXT statement is processed. *address-value* must be left justified within the string constant.

- An IPv4 address is represented as a dotted decimal address. An example of an IPv4 address is 9.112.46.111.
- An IPv6 address is represented as a colon hexadecimal address. An example of an IPv6 address is 2001:0DB8:0000:0000:0008:0800:200C:417A. This address can also be expressed in a compressed form as 2001:DB8::8:800:200C:417A.
- A domain name is converted to an IP address by the domain name server where a resulting IPv4 or IPv6 address is determined. An example of a domain name is www.ibm.com. The gethostbyname socket call is used to resolve the domain name.

ENCRYPTION *encryption-value*

Specifies the minimum level of encryption of the data stream (network encryption) for the connection.

encryption-value specifies a string constant that contains the value that is associated with the ENCRYPTION trust attribute. *encryption-value* must be left justified within the string constant.

ENCRYPTION must not be specified more than one time in the statement. *encryption-value* must be one of the following:

- NONE, which specifies that no specific level of encryption is required.
- LOW, which specifies that a minimum of light encryption is required. LOW corresponds to 64-bit DRDA encryption.
- HIGH, which specifies that strong encryption is required. HIGH corresponds to SSL encryption.

ENCRYPTION cannot be specified if ADD ATTRIBUTES is specified. See “CREATE TRUSTED CONTEXT statement” on page 1787 for more information about the ENCRYPTION attribute.

JOBNAME *jobname-value*

Specifies the z/OS job name or started task name (depending on the source of the address space) for local applications. Previously specified values for JOBNAME are removed when ALTER ATTRIBUTES is specified. The JOBNAME attribute can be specified multiple times, but each *jobname-value* must be unique.

jobname-value specifies a string constant that contains the value that is associated with the JOBNAME trust attribute. *jobname-value* is an EBCDIC 8 byte job name or started task name. *jobname-value* must be left justified within the string constant. The last character in the name can be a wildcard character (*) if the first character is an alphabetic character. If the job name ends with a wildcard, any job names that match the specified characters are considered for establishing the trusted connection.

The following table lists possible values for the job name depending on the source of the address space).

Table 194. Job name for local connection

Source of the address space	Job name
RRSAF	Job name or started task name
TSO	TSO logon ID
BATCH	Job name on JOB statement

SERVAUTH *servauth-value*

Specifies the name of a resource in the RACF SERVAUTH class. This resource is the network access security zone name that contains the IP address of the connection that is used to communicate with Db2. Previously specified values for SERVAUTH are removed when ALTER ATTRIBUTES is specified. The SERVAUTH attribute can be specified multiple times but each *servauth-value* must be unique.

servauth-value specifies a string constant that contains the value that is associated with the SERVAUTH trust attribute. *servauth-value* is an EBCDIC 64 byte RACF SERVAUTH CLASS resource name. *servauth-value* must be left justified in the string constant. No validation of *servauth-value* is done at the time the ALTER TRUSTED CONTEXT statement is processed.

DROP ATTRIBUTES

Specifies that one or more attributes are dropped from the definition of a trusted context. If the attribute is not currently specified as part of the definition of a trusted context, an error is returned. The specification of DROP ATTRIBUTES must not attempt to drop all of the existing attributes for a trusted context.

ADDRESS *address-value*

Specifies that the identified communication address is removed from the definition of the trusted context. *address-value* specifies a string constant that contains the value of an existing ADDRESS trust attribute.

JOBNAME *jobname-value*

Specifies that the identified job name is removed from the definition of the trusted context. *jobname-value* specifies a string constant that contains the value of an existing JOBNAME trust attribute.

SERVAUTH *servauth-value*

Specifies that the identified servauth that is removed from the definition of the trusted context. *servauth-value* specifies a string constant that contains the value of an existing SERVAUTH trust attribute.

ADD USE FOR

Specifies additional users who can use a trusted connection that is based on the specified trusted context.

authorization-name

Specifies that the trusted connection can be used by the specified *authorization-name*. This is the Db2 primary authorization ID. The *authorization-name* must not identify an authorization ID that is already defined to use the trusted context, and must not be specified more than one time in the ADD USE FOR clause.

ROLE *role-name*

Specifies that *role-name* is the role that is used when a trusted connection is used by the specified *authorization-name*. The *role-name* must identify a role that exists at the current server. The role that is explicitly specified for the user overrides any default role that is associated with the trusted context.

SECURITY LABEL *seclabel-name*

Specifies that *seclabel-name* is the security label to use for multilevel security verification when the trusted connection is used by the specified *authorization-name*. The *seclabel-name* must be one of the RACF SECLABEL values that is defined for the user. The security label that is explicitly specified for the user overrides any default security label that is associated with the trusted context.

EXTERNAL SECURITY PROFILE *profile-name*

Specifies that the trusted connection can be used by the Db2 primary authorization IDs that are permitted to use the specified *profile-name* in RACF. *profile-name* must not already be defined to use the trusted context, and must not be specified more than one time in the ADD USE FOR clause. If an authorization ID is permitted to use more than one specified *profile-name*, the role that is specified for *profile-name* can be associated with the process if the user authentication satisfies the AUTHENTICATION definition. This role can hold additional privileges that are available to the process.

After you specify an external security profile, any user who is permitted access to the RACF profile can use the trusted context in addition to any users that are specified using the ADD USE FOR *authorization-name* clause.

ROLE *role-name*

Specifies that *role-name* is the role that is used when a trusted connection is used by any authorization ID that is permitted to use the specified *profile-name* in RACF. The *role-name* must identify a role that exists at the current server. The role that is explicitly specified for the profile overrides any default role that is associated with the trusted context.

SECURITY LABEL *seclabel-name*

Specifies that *seclabel-name* is the security label to use for multilevel security verification when the trusted connection is used by any authorization ID that is permitted to use the specified *profile-name* in RACF. The *seclabel-name* must be one of the RACF SECLABEL values that is defined for the user. The security label that is explicitly specified for the profile overrides any default security label that is associated with the trusted context.

PUBLIC

Specifies that a trusted connection that is based on the specified trusted context can be used by any user. PUBLIC must not already be defined to use the trusted context and must not be specified more than one time in the ADD USE FOR clause.

All users that are using a trusted connection that is defined with PUBLIC use the privileges that are associated with the default role for the associated trusted context. If the default role is not defined for the trusted context, there is no role associated with the users that use a trusted connection that is based on the specified trusted context.

If the default security label for the trusted context is defined, all users that are using the trusted context must have the security label defined as one of the RACF SECLABEL values for the user. The default security label is used for multilevel security verification with all users that are using the trusted context.

The specifications for a user are determined in the following order of precedence:

- *authorization-name*
- EXTERNAL SECURITY PROFILE *profile-name*
- PUBLIC

For example, assume that a trusted context is defined with use for JOE WITH AUTHENTICATION, EXTERNAL SECURITY PROFILE SPROFILE WITHOUT AUTHENTICATION (with JOE and SAM permitted to use the RACF PROFILE SPROFILE), and PUBLIC WITH AUTHENTICATION. If the trusted connection is used by JOE, authentication is required. If the trusted connection is used by SAM, authentication is not required. However, if the trusted connection is used by SALLY, authentication is required.

REPLACE USE FOR

Specifies a change to the specified user or PUBLIC for who can use the trusted context.

authorization-name

Specifies the *authorization-name* that is changed for use of the trusted context. The trusted context must already be defined to allow use by *authorization-name*, and *authorization-name* must not be specified more than one time in the REPLACE USE FOR clause. The information that is associated with *authorization-name* is changed as indicated.

ROLE *role-name*

Specifies that *role-name* is the role that is used when a trusted connection is using the specified trusted context. The *role-name* must identify a role that exists at the current server. The role that is explicitly specified for the user overrides any default role that is associated with the trusted context.

SECURITY LABEL *seclabel-name*

Specifies that *seclabel-name* is the security label to use for multilevel security verification when the trusted connection is used by the specified *authorization-name*. The *seclabel-name* must be one of the RACF SECLABEL values that is defined for the user. The security label that is explicitly specified for the user overrides any default security label that is associated with the trusted context.

EXTERNAL SECURITY PROFILE *profile-name*

Specifies the *profile-name* to change attributes for use of the trusted connection. The trusted context must already be defined to allow the use of *profile-name*. *profile-name* must not be specified more than one time in the REPLACE USE FOR clause. The information that is associated with the profile name is changed as indicated.

ROLE *role-name*

Specifies that *role-name* is the role that is used when a trusted connection is used by any authorization ID that is permitted to use the specified *profile-name* in RACF. The role name must identify a role that exists at the current server. The role that is explicitly specified for the profile overrides any default role that is associated with the trusted context.

SECURITY LABEL *seclabel-name*

Specifies that *seclabel-name* is the security label to use for multilevel security verification when the trusted connection is used by any authorization ID that is permitted to use the specified *profile-name* in RACF. The *seclabel-name* must be one of the RACF SECLABEL values that is defined for the user. The security label that is explicitly specified for the user overrides any default security label that is associated with the trusted context.

PUBLIC

Specifies that the attributes for use of the trusted connection by PUBLIC are to be changed. PUBLIC must already be defined to use the trusted context, and PUBLIC must not be specified more than one time in the REPLACE USE FOR clause.

All users that are using a trusted connection that is defined with PUBLIC use the privileges that are associated with the default role for the associated trusted context. If the default role is not defined for the trusted context, there is no role associated with the users that use a trusted connection that is based on the specified trusted context.

If the default security label for the trusted context is defined, all users that are using the trusted context must have the security label defined as one of the RACF SECLABEL values for the user. The default security label is used for multilevel security verification with all users that are using the trusted context.

WITHOUT AUTHENTICATION or WITH AUTHENTICATION

Specifies whether use of the trusted connection requires authentication of the user.

WITHOUT AUTHENTICATION

Specifies that use of a trusted connection by the user does not require authentication. WITHOUT AUTHENTICATION is the default.

WITH AUTHENTICATION

Specifies that use of a trusted connection requires the authentication token with the authorization ID to authenticate the user.

DROP USE FOR

Specifies who can no longer use the trusted context. The users that are removed from the definition of the trusted context are the specified users (or PUBLIC) that are currently allowed to use the trusted context. If multiple users are specified to be dropped, and one or more of those users cannot be dropped, those users that can be dropped are dropped and a warning is returned. If none of the specified users can be removed from the definition of the trusted context, an error is returned.

authorization-name

Specifies the *authorization-name* that will no longer be able to use this trusted context.

EXTERNAL SECURITY PROFILE *profile-name*

Removes the ability for the specified *profile-name* to use the trusted context.

PUBLIC

Specifies that PUBLIC users will no longer be able to use this trusted context. The system authorization ID and individual authorization IDs that have been explicitly enabled can still use the trusted context.

Notes for ALTER TRUSTED CONTEXT

Precedence for authorization-name and authentication requirements: If the *authorization-name* that is specified in the SYSTEM AUTHID clause is the same authorization name that is specified in the ADD or REPLACE USE FOR *authorization-name* clauses, the role or the security label that is specified for the *authorization-name* takes precedence over the default value and the value that is specified for the EXTERNAL SECURITY PROFILE *profile-name* (if one is specified). If the authorization name that is specified in the SYSTEM AUTHID clause is permitted to use one of the specified profile names and is not specified in ADD or REPLACE USE for *authorization-name*, the role or the security label that is specified for that *profile-name* takes precedence over the default value.

Authentication is required for SYSTEM AUTHID if the AUTHENTICATION clause is specified in the ADD or REPLACE USE FOR clauses, or if the subsystem parameter TCP/IP Already Verified is set to NO. For example, if *authorization-name* is the same as the authorization name that is specified in the SYSTEM AUTHID clause and the WITHOUT AUTHENTICATION clause is specified, but the TCP/IP Already Verified subsystem parameter is set to NO, authentication is required for SYSTEM AUTHID when the remote trusted connection is established. If *authorization-name* is the SYSTEM AUTHID and the WITH

AUTHENTICATION clause is specified, but the TCP/IP Already Verified subsystem parameter is set to YES, authentication is still required for SYSTEM AUTHID.

Order of precedence for users of a trusted connection: The specifications for a user are determined in the following order of precedence:

- *authorization-name*
- EXTERNAL SECURITY PROFILE *profile-name*
- PUBLIC

For example, assume that a trusted context is defined with use for JOE WITH AUTHENTICATION, EXTERNAL SECURITY PROFILE SPROFILE WITHOUT AUTHENTICATION, and PUBLIC WITH AUTHENTICATION. Users JOE and SAM are permitted to use the RACF PROFILE SPROFILE. If the trusted connection is used by JOE, authentication is required. If the trusted connection is used by SAM, authentication is not required. However, if user SALLY uses the trusted connection, authentication is required.

User-clause SYSTEM AUTHID considerations: If the *authorization-name* that is specified in the SYSTEM AUTHID clause is the same as the *authorization-name* that is specified in the user-clause *authorization-name*, the role or the security label that is specified for *authorization-name* takes precedence over the default value. The value that is specified for the *profile-name*, is permitted to use the profile. If the authorization name that is specified in the SYSTEM AUTHID clause is permitted to use one of the profile names and is not defined in *authorization-name*, the role or the security label that is specified for that *profile-name* takes precedence over the default value.

If authentication is required for SYSTEM AUTHID, either by specification of the AUTHENTICATION clause in the *user-clause* or by setting the value of the TCP/IP Already Verified subsystem parameter to NO, the authentication requirement takes precedence when establishing a remote trusted connection. For example, if *authorization-name* is the same as the authorization name that is specified for SYSTEM AUTHID and the WITHOUT AUTHENTICATION clause is specified, but the TCP/IP Already Verified subsystem parameter is set to NO, an authentication token is required for SYSTEM AUTHID when the remote trusted connection is established. If *authorization-name* is the SYSTEM AUTHID and the WITH AUTHENTICATION clause is specified, but the TCP/IP Already Verified subsystem parameter is set to YES, an authentication token is still required for SYSTEM AUTHID.

Order of operations: The order in which the clauses of the ALTER TRUSTED CONTEXT statement are applied are as follows:

- DROP ATTRIBUTES
- DROP USE FOR
- ALTER
- ADD ATTRIBUTES
- ADD USE FOR
- REPLACE USE FOR

Effect of changes on existing trusted connections: If trusted connections exist for the trusted context that is changed, the connections continue to use the unchanged definition of the trusted context until the connection is terminated or an attempt at reuse is made. If the trusted context is disabled while there are active trusted connections that are based on this trusted context, the connections continue to be used until terminated or an attempt at reuse is made. If the trust attributes are changed, trusted connections that exist at the time that the trusted context is changed will continue to be used.

When changes to a trusted context take place: The changes to the definition of a trusted context take effect after the ALTER TRUSTED CONTEXT statement is committed. If the ALTER TRUSTED CONTEXT statement results in an error or is rolled back, the trusted context is not changed.

Role privileges: If no role is associated with the user or the trusted context, only the privileges that are associated with the user are applicable. This is the same as not using a trusted context.

Examples for ALTER TRUSTED CONTEXT

Example 1: The following statement updates the default role of the trusted context CTX1:

```
ALTER TRUSTED CONTEXT CTX1
ALTER DEFAULT ROLE CTXROLE2;
```

Example 2: The following statement changes the CTX3 trusted context to allow use for BILL, and it also puts the trusted context into the disabled state:

```
ALTER TRUSTED CONTEXT CTX3
DISABLE
ADD USE FOR BILL;
```

Example 3: The following statement changes the CTX4 trusted context to allow the previously defined user JOE to use the trusted context without authentication. The statement also adds use for PUBLIC with authentication and TOM with a role of SPLROLE:

```
ALTER TRUSTED CONTEXT CTX4
REPLACE USE FOR JOE WITHOUT AUTHENTICATION
ADD USE FOR PUBLIC WITH AUTHENTICATION,
TOM ROLE SPLROLE;
```

Example 4: The following statement changes the REMOTECTX to use a different IPv4 address than it was originally defined to use. It also changes the encryption settings from NONE to LOW. After the ALTER statement is processed, the connection will be considered trusted only when it is established from 9.12.155.200 with low encryption. The connection will no longer be considered trusted if it is established from the previously defined addresses:

```
ALTER TRUSTED CONTEXT REMOTECTX
ALTER ATTRIBUTES (ADDRESS '9.12.155.200',
ENCIPHERMENT 'LOW');
```

ALTER VIEW statement

The ALTER VIEW statement regenerates a view using an existing view definition at the current server. ALTER VIEW is primarily used during Db2 migration or when Db2 maintenance is applied. To change a view definition (for example, to add additional columns), you must drop the view and create a new view using the CREATE VIEW statement.

Invocation for ALTER VIEW

This statement can be embedded in an application program or issued interactively. It is an executable statement that can be dynamically prepared only if DYNAMICRULES RUN behavior is in effect. For more information, see [“Authorization IDs and dynamic SQL”](#) on page 94.

Authorization for ALTER VIEW

The privilege set that is defined below must include at least one of the following:

- Ownership of the view
- SYSADM authority
- SYSCTRL authority
- System DBADM

Privilege set: If the statement is embedded in an application program, the privilege set is the privileges that are held by the owner of the package. If the statement is dynamically prepared, the privilege set is the union of the privilege sets that are held by each authorization ID and role of the process.

Syntax for ALTER VIEW

```
▶ ALTER VIEW — view-name — REGENERATE →  
  
┌───────────────────────────────────────────────────────────────────────────────────┐  
│ USING APPLICATION COMPATIBILITY — applcompat-level │  
└───────────────────────────────────────────────────────────────────────────────────┘
```

Description for ALTER VIEW

view-name

Identifies the view to be regenerated. The name must identify a view that exists at the current server.

REGENERATE

Specifies that the view is to be regenerated. The view definition in the catalog is used, and existing authorizations and dependent views are retained. The catalog is updated with the regenerated view definition. If the view cannot be successfully regenerated, an error is returned.

Generally, the REGENERATE keyword is used only for specific situations, such as when implicit regeneration fails for routines or objects, or Db2 maintenance requires objects or routines to be regenerated. For more information, see [When to regenerate Db2 database objects and routines \(Db2 Administration Guide\)](#).

USING APPLICATION COMPATIBILITY *applcompat-level*

Specifies that the object is regenerated under *applcompat-level* application compatibility rules. The ALTER statement fails if it includes any syntax, semantics, or options that require a higher application compatibility level.

If USING APPLICATION COMPATIBILITY is omitted, the regeneration uses the APPLCOMPAT value of the applicable SYSIBM.SYSENVIRONMENT catalog table row.

The following *applcompat-level* values can be specified:

VuuRrMmmm

Compatibility with the behavior of the identified Db2 function level. For example, V12R1M510 specifies compatibility with the highest available Db2 12 function level. The equivalent function level or higher must be activated.

For the new capabilities that become available in each application compatibility level, see:

- [SQL changes in Db2 13 application compatibility levels](#)
- [SQL changes in Db2 12 application compatibility levels](#)

Tip: Extra program preparation steps might be required to increase the application compatibility level for applications that use data server clients or drivers to access Db2 for z/OS. For more information, see [Setting application compatibility levels for data server clients and drivers \(Db2 Application programming and SQL\)](#).

V12R1

Compatibility with the behavior of Db2 12 function level 500. This value has the same result as specifying V12R1M500.

V11R1

Compatibility with the behavior of Db2 11 new-function mode. After migration to Db2 12, this value has the same result as specifying V12R1M100. For more information, see [V11R1 application compatibility level \(Db2 Application programming and SQL\)](#)

V10R1

Compatibility with the behavior of DB2 10 new-function mode. For more information, see [V10R1 application compatibility level \(Db2 Application programming and SQL\)](#).

Examples for ALTER VIEW

Check the catalog to find any views that were marked with view regeneration errors during catalog migration:

```
SELECT CREATOR,NAME FROM SYSIBM.SYSTABLES
WHERE TYPE = 'V' AND STATUS = 'R' AND TABLESTATUS = 'V';
```

Assume that the query returned MYVIEW as the name of a view with a regeneration error. Issue an ALTER VIEW statement to regenerate the view:

```
ALTER VIEW MYVIEW REGENERATE;
```

ASSOCIATE LOCATORS statement

The ASSOCIATE LOCATORS statement gets the result set locator value for each result set returned by a stored procedure.

Invocation for ASSOCIATE LOCATORS

This statement can be embedded in an application program. It is an executable statement that can be dynamically prepared. It cannot be issued interactively.

Authorization for ASSOCIATE LOCATORS

None required.

Syntax for ASSOCIATE LOCATORS

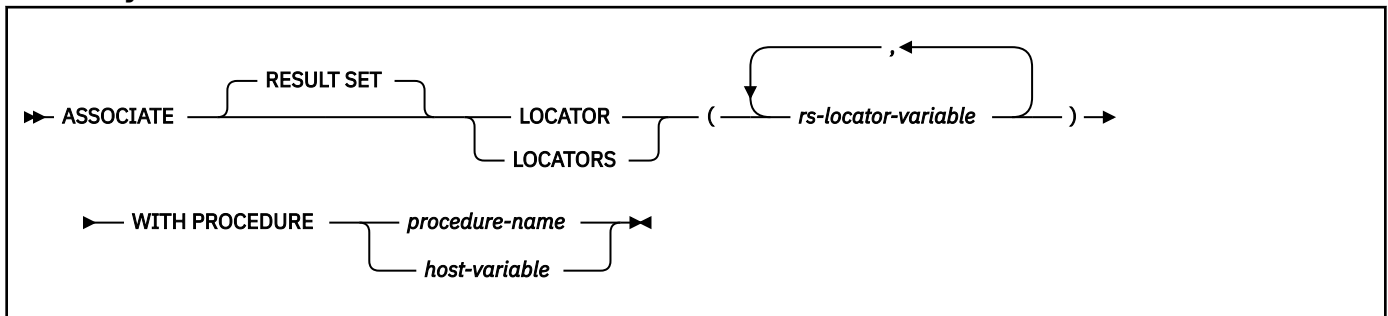

Description for ASSOCIATE LOCATORS

rs-locator-variable

Identifies a result set locator variable that has been declared according to the rules for declaring result set locator variables.

WITH PROCEDURE *procedure-name* or *host-variable*

Identifies the stored procedure that returned one or more result sets. When the ASSOCIATE LOCATORS statement is executed, the procedure name must identify a stored procedure that the requester has already invoked using the SQL CALL statement. The procedure name can be specified as a one-part, two-part, or three-part name. The procedure name in the ASSOCIATE LOCATORS statement must be specified the same way that it was specified on the CALL statement. For example, if a two-part procedure name was specified on the CALL statement, you must specify a two-part procedure name in the ASSOCIATE LOCATORS statement.

If a host variable is used to specify the name:

- It must be a character string variable with a length attribute that is not greater than 255.
- It must not be followed by an indicator variable.

- The value of the host variable is a specification that depends on the server. Regardless of the server, the specification must:
 - Be left justified within the host variable
 - Not contain embedded blanks
 - Be padded on the right with blanks if its length is less than that of the host variable

Notes for ASSOCIATE LOCATORS

Assignment of locator values: If the ASSOCIATE LOCATORS statement specifies multiple locator variables, locator values are assigned to the locator variables in the order that the associated cursors are opened regardless of whether they are still open or not at run time. Locator values are assigned to the locator variables in the same order that they would be placed in the SQLVAR entries in the SQLDA as a result of a DESCRIBE PROCEDURE statement.

Locator values are not provided for cursors that are closed when control is returned to the invoking application. If a cursor was closed and later opened again before returning to the invoking application, the most recently executed OPEN CURSOR statement for the cursor is used to determine the order in which the locator values are returned for the procedure result sets. For example, assume procedure P1 opens three cursors A, B, C, closes cursor B and then issues another OPEN CURSOR statement for cursor B before returning to the invoking application. The locator values assigned for the following ASSOCIATE LOCATORS statement will be in the order A, C, B:

```
ASSOCIATE RESULT SET LOCATORS (:loc1, :loc2, :loc3) WITH PROCEDURE P1;
-- assigns locators for result set cursors A, C, and B
```

More than one locator can be associated with a result set. You can issue multiple ASSOCIATE LOCATORS statements for the same stored procedure with different result set locator variables to associate multiple locators with each result set.

- If the number of result set locator variables specified in the ASSOCIATE LOCATORS statement is less than the number of result sets returned by the stored procedure, all locator variables specified in the statement are assigned a value, and a warning is issued. For example, assume procedure P1 exists and returns four result sets. Each of the following ASSOCIATE LOCATORS statement returns information on the first result set along with a warning that not enough locators were provided to obtain information about all the result sets.

```
CALL P1;
ASSOCIATE RESULT SET LOCATORS (:loc1) WITH PROCEDURE P1;
-- :loc1 is assigned a value for first result set, and a warning is returned
ASSOCIATE RESULT SET LOCATORS (:loc2) WITH PROCEDURE P1;
-- :loc2 is assigned a value for first result set, and a warning is returned
ASSOCIATE RESULT SET LOCATORS (:loc3) WITH PROCEDURE P1;
-- :loc3 is assigned a value for first result set, and a warning is returned
ASSOCIATE RESULT SET LOCATORS (:loc4) WITH PROCEDURE P1;
-- :loc4 is assigned a value for first result set, and a warning is returned
```

- If the number of result set locator variables that are listed in the ASSOCIATE LOCATORS statement is greater than the number of locators returned by the stored procedure, the extra locator variables are assigned a value of 0.

Accessing result sets from multiple CALL statements: An application can access to result sets created by multiple CALL statements. The result sets can be created by different procedure or by the same procedure invoked multiple times.

- *Invoking different procedures:* Invoking different procedures with the same name can be done either explicitly by specifying the different collections or implicitly with the use of the PACKAGE PATH. For example, to identify the different collections explicitly, specify qualified names on the CALL statement. Although both procedures are named P2, they are different procedures. After the second CALL statement, result sets from both procedures are accessible to the application.

```
CALL X.P2;
CALL Y.P2;
```

The collections for the two different procedures can also be determined implicitly from the PACKAGE PATH when unqualified procedure names are specified as part of the CALL statement. For example, assume that procedure P4 exists in collections X and Z. An application contains two CALL statements to invoke procedure P4. The references to procedure P4 in the CALL statements are unqualified. So, the PACKAGE PATH special register is used to resolve the procedure name. Procedure X.P4 is invoked for the first CALL statement and procedure Z.P4 is invoked by the second CALL statement. Following the second CALL statement, result sets from both procedures are accessible to the application.

```
SET CURRENT PACKAGE PATH = X, Y, Z;
CALL P4;
SET CURRENT PACKAGE PATH = PATH Z, Y, X;
CALL P4;
```

- **Invoking the same procedure multiple times:** If the server and requester are both the same version of Db2, you can call a stored procedure multiple times within an application and at the same nesting level. Each call to the same stored procedure causes a unique instance of the stored procedure to run. If the stored procedure returns result sets, each instance of the stored procedure opens its own set of result set cursors. For more information on this situation, see [Multiple calls to the same stored procedure](#).

When a procedure is invoked multiple times in an application and there is a need to process the result sets from the different instances at the same time, be sure to use the ASSOCIATE LOCATORS statement after each CALL statement to capture the locator values returned from each invocation of the procedure. For example, assume that procedure P exists in collection Z and that an application contains two CALL statements to invoke procedure P. The PACKAGE PATH is used to determine the collection for the procedure in the first CALL statement, and the collection is explicitly specified in the second CALL statement. Result sets from both procedures can be accessible to the application following both CALL statements if the locators for the result sets produced by the first CALL statement are captured with an ASSOCIATE LOCATOR statement before invoking the procedure the second time.

```
SET CURRENT PACKAGE PATH = X, Y, Z;
CALL P3;
ASSOCIATE LOCATORS ...
CALL Z.P3;
ASSOCIATE LOCATORS ...
-- process the result sets using the locators
```

Using host variables: If the ASSOCIATE LOCATORS statement contains host variables, the following conditions apply:

- If the statement is executed statically, the contents of the host variables are assumed to be in the encoding scheme that was specified in the ENCODING parameter when the package or plan that contains the statement was bound.
- If the statement is executed dynamically, the contents of the host variables are assumed to be in the encoding scheme that is specified in the APPLICATION ENCODING bind option.

Examples for ASSOCIATE LOCATORS

The statements in the following examples are assumed to be in PL/I programs.

Example 1: Use result set locator variables LOC1 and LOC2 to get the result set locator values for the two result sets returned by stored procedure P1. Assume that the stored procedure is called with a one-part name from current server SITE2.

```
EXEC SQL CONNECT TO SITE2;
EXEC SQL CALL P1;
EXEC SQL ASSOCIATE RESULT SET LOCATORS (:LOC1, :LOC2)
      WITH PROCEDURE P1;
```

Example 2: Repeat the scenario in Example 1, but use a two-part name to specify an explicit schema name for the stored procedure to ensure that stored procedure P1 in schema MYSCHEMA is used.

```
EXEC SQL CONNECT TO SITE2;
EXEC SQL CALL MYSCHEMA.P1;
```

```
EXEC SQL ASSOCIATE RESULT SET LOCATORS (:LOC1, :LOC2)
WITH PROCEDURE MYSCHEMA.P1;
```

Example 3: Use result set locator variables LOC1 and LOC2 to get the result set locator values for the two result sets that are returned by the stored procedure named by host variable HV1. Assume that host variable HV1 contains the value SITE2.MYSCHEMA.P1 and the stored procedure is called with a three-part name.

```
EXEC SQL CALL SITE2.MYSCHEMA.P1;
EXEC SQL ASSOCIATE LOCATORS (:LOC1, :LOC2)
WITH PROCEDURE :HV1;
```

The preceding example would be invalid if host variable HV1 had contained the value MYSCHEMA.P1, a two-part name. For the example to be valid with that two-part name in host variable HV1, the current server must be the same as the location name that is specified on the CALL statement as the following statements demonstrate. This is the only condition under which the names do not have to be specified the same way and a three-part name on the CALL statement can be used with a two-part name on the ASSOCIATE LOCATORS statement.

```
EXEC SQL CONNECT TO SITE2;
EXEC SQL CALL SITE2.MYSCHEMA.P1;
EXEC SQL ASSOCIATE LOCATORS (:LOC1, :LOC2)
WITH PROCEDURE :HV1;
```

BEGIN DECLARE SECTION statement

The BEGIN DECLARE SECTION statement marks the beginning of an SQL declare section. An SQL declare section contains declarations of host variables that are eligible to be used as host variables in SQL statements in a program.

Invocation for BEGIN DECLARE SECTION

This statement can only be embedded in an application program. It is not an executable statement. It must not be specified in Java or REXX.

Authorization for BEGIN DECLARE SECTION

None required.

Syntax for BEGIN DECLARE SECTION

►► BEGIN DECLARE SECTION ◀◀

Description for BEGIN DECLARE SECTION

The BEGIN DECLARE SECTION statement can be coded in the application program wherever variable declarations can appear in accordance with the rules of the host language. It is used to indicate the beginning of a host variable declaration section. A host variable section ends with an END DECLARE SECTION statement, described in “END DECLARE SECTION statement” on page 1907.

The following rules are enforced by the precompiler only if the host language is C or the STDSQL(YES) SQL processing option is specified:

- A variable referred to in an SQL statement must be declared within a host variable declaration section of the source program in all host languages, other than Java and REXX. Furthermore, the declaration of each variable must appear before the first reference to the variable. Host variables are declared without the use of these statements in Java, and they are not declared at all in REXX.
- BEGIN DECLARE SECTION and END DECLARE SECTION statements must be paired and must not be nested.

- Host variable declaration sections can contain only host variable declarations, SQL INCLUDE statements that include host variable declarations, or DECLARE VARIABLE statements.

Notes for BEGIN DECLARE SECTION

Host variable declaration sections are only required if the STDSQL(YES) option is specified or the host language is C. However, declare sections can be specified for any host language so that the source program can conform to IBM SQL. If declare sections are used, but not required, variables declared outside a declare section must not have the same name as variables declared within a declare section.

Example for BEGIN DECLARE SECTION

```
EXEC SQL BEGIN DECLARE SECTION;  
  -- host variable declarations  
EXEC SQL END DECLARE SECTION;
```

CALL statement

The CALL statement invokes a stored procedure.

Invocation for CALL

This statement can be embedded in an application program. This statement can be executed interactively using the command line processor. Refer to [Command line processor CALL statement \(Db2 Application programming and SQL\)](#) for information about using the command line processor with the CALL statement. This statement can also be dynamically prepared, but only from an ODBC or CLI driver that supports dynamic CALL statements. IBM's ODBC and CLI drivers provide this capability.

Authorization for CALL

Invoking a stored procedure requires the EXECUTE privilege on the following:

- The stored procedure

You do not need the EXECUTE privilege on a stored procedure that was created prior to Version 6 of Db2 for z/OS.

- Additional authority is needed for the stored procedure package and most packages that run in the stored procedure.

The authorization that is required for which packages is explained in detail in [Authorization to execute packages under the stored procedure](#).

Authorization to execute the stored procedure

The authorization ID or role that must have the EXECUTE privilege on the stored procedure depends on the form of the CALL statement:

- For static SQL programs that use the syntax `CALL procedure`, the owner of the plan or package that contains the CALL statement must have one of the following:
 - The EXECUTE privilege on the stored procedure
 - Ownership of the stored procedure
 - DATAACCESS authority
 - SYSADM authority
- For static SQL programs that use the syntax `CALL variable`, the authorization ID or role of the plan or package that contains the CALL statement must have one of the following:

- The EXECUTE privilege on the stored procedure
- Ownership of the stored procedure
- DATAACCESS authority
- SYSADM authority

The DYNAMICRULES behavior for the plan or package that contains the CALL statement determines both the authorization ID or role and the privilege set that is held by that authorization ID or role:

Run behavior

The privilege set is the union of the set of privileges that are held by the SQL authorization ID and each authorization ID or role of the process.

Bind behavior

The privilege set is the privileges that are held by the primary authorization ID of the owner of the package or plan.

Define behavior

The privilege set is the privileges that are held by the authorization ID or role of the owner (definer) of the stored procedure or user-defined function that issued the CALL statement.

Invoke behavior

The privilege set is the privileges that are held by the authorization ID or role of the invoker of the stored procedure or user-defined function that issued the CALL statement. However, if the invoker is the primary authorization ID of the process or the CURRENT SQLID value, the privilege set is the union of the set of privileges that are held by each authorization ID or role.

For a list of the DYNAMICRULES values that specify run, bind, define, or invoke behavior, see [Table 14 on page 94](#).

Authorization to execute packages under the stored procedure (including nested stored procedures)

The authorization that is required to run the stored procedure package and any packages that are used under the stored procedure (including nested stored procedures) apply to any form of the CALL statement as follows:

- **Stored procedure package:** One of the authorization IDs or roles that are defined in [Set of authorization IDs](#) must have at least one of the following privileges or authorities on the stored procedure package:
 - The EXECUTE privilege
 - Ownership of the package
 - PACKADM authority for the package's collection
 - SYSADM authority

A PKLIST entry is not required for the stored procedure package.

- **User-defined function packages and trigger packages:** If a stored procedure or any application under the stored procedure invokes a user-defined function, Db2 requires only the owner (the definer), and not the invoker of the user-defined function, to have EXECUTE authority on the user-defined function package. However, the authorization ID or role of the SQL statement that invokes the user-defined function must have EXECUTE authority on the function.

Similarly, if a trigger is used under a stored procedure, Db2 does not require EXECUTE authority on the trigger package; however, the authorization ID or role of the SQL statement that activates the trigger must have EXECUTE authority on the trigger.

PKLIST entries are not required for any user-defined function packages or trigger packages that are used under the stored procedure.

- **Packages other than user-defined function, trigger, and stored procedure packages:** One of the authorization IDs or roles that is defined below under [Set of authorization IDs](#) must have at least one of the following privileges or authorities on any packages other than user-defined function and trigger packages that are used under the stored procedure:
 - The EXECUTE privilege

- Ownership of the package
- PACKADM authority for the package's collection
- SYSADM authority

PKLIST entries are required for any of these packages that are used under the stored procedure.

For improved performance and simplicity, consider granting the EXECUTE ON PACKAGE privilege for the stored procedure package, and for any packages that run under the stored procedure, to the owner of the stored procedure.

Set of authorization IDs: Db2 checks the following authorization IDs, in the order in which they are listed, for the required authorization to execute the stored procedure package and any packages that run under the stored procedure other than user-defined function and trigger packages as described previously. Authorization checking ends after the first authorization ID that has EXECUTE ON PACKAGE privileges for the target package is found.

- The owner (the definer) of the stored procedure.
- The owner of the plan that contains the CALL statement that invokes the stored procedure if either of the following conditions is true:
 - The calling application (a package or a DBRM that is bound directly to the plan) is local.
 - The calling application is distributed, the Db2 subsystem is both the requester and the server, and the PRIVATE_PROTOCOL subsystem parameter is not set to NO.
- The owner of the package that contains the CALL statement that invokes the stored procedure if the calling application is distributed and either of the following conditions is true:
 - The Db2 subsystem is the server but not the requester.
 - The Db2 subsystem is both the server and the requester and the PRIVATE_PROTOCOL subsystem parameter is set to NO.
 - The calling application uses Recoverable Resources Management Services attachment facility (RRSAF) and has no plan.
- The authorization ID as determined by the value of the DYNAMICRULES bind option for the plan or package that contains the CALL statement if the CALL statement is in the form of CALL *variable*.
 - If the calling application is bound with the DYNAMICRULES(RUN) option, Db2 checks either the authorization ID of the process at run time and its secondary authorization IDs or the single authorization ID that is determined by the other DYNAMICRULES bind option values.
 - If the calling application is bound with a value other than DYNAMICRULES(RUN), Db2 checks only a single authorization ID, even if that ID fails the EXECUTE ON PACKAGE authorization check.
 - If the calling application is a package and is bound with DYNAMICRULES(BIND), Db2 checks the authorization ID of the package owner. Db2 does not check the authorization ID of the plan owner.

Authorization to execute packages for remote statements in a stored procedure: Remotely executed SQL statements in a stored procedure follow the same authorization rules as remotely executed SQL statements in a stand-alone application. If a stored procedure connects to a remote Db2 server and executes SQL statements at that server, the setting of the PRIVATE_PROTOCOL subsystem parameter at the server determines the IDs to which the EXECUTE privilege for the package that includes the SQL statements must be granted.

See [“DRDA access with Db2 for z/OS only”](#) on page 96 for more information.

Syntax for CALL

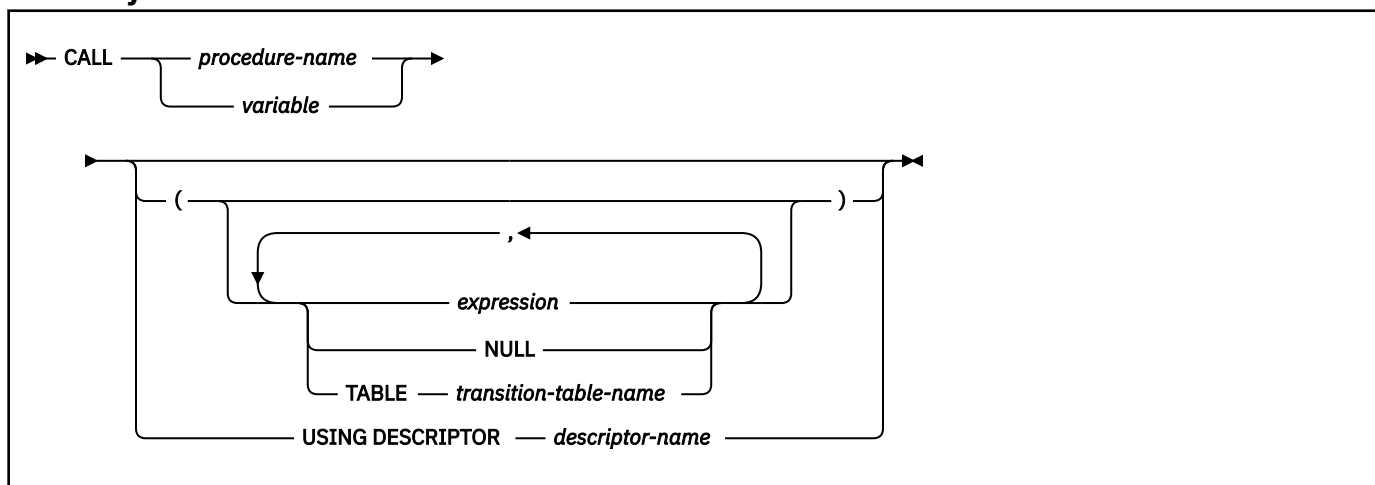

Description for CALL

procedure-name* or *variable

Identifies the procedure to call by the specified *procedure-name* or the procedure name contained in the *variable*. The identified procedure must exist at the current server.

If *procedure-name* specifies any of the three special characters that are alphabetic extenders for national languages, \$#@, specify the procedure name with a *variable*.

If a variable is used:

- It must be a CHAR or VARCHAR variable with a length attribute that is not greater than 254.
- It must not be followed by an indicator variable.
- The value of the variable is a specification that depends on the server. Regardless of the server, the specification must:
 - Be left justified within the variable
 - Not contain embedded blanks
 - Be padded on the right with blanks if its length is less than that of the variable

In addition, the specification can:

- Contain upper and lowercase characters. Lowercase characters are not folded to uppercase.
- Use a delimited identifier for any part of a three-part procedure name.

If the server is Db2 for z/OS, the specification must be a procedure name as defined above.

When the CALL statement is executed, the procedure name or specification must identify a stored procedure that exists at the server.

When the package that contains the CALL statement is bound, the stored procedure that is invoked must be created if VALIDATE(BIND) is specified. Although the stored procedure does not need to be created at bind time if VALIDATE(RUN) is specified, it must be created when the CALL statement is executed.

expression*, *NULL*, or *TABLE transition-table-name

Identifies a list of values to be passed as arguments to the stored procedure. The *n*th value corresponds to the *n*th parameter in the procedure. Each parameter that is defined using CREATE PROCEDURE as OUT or INOUT must be specified as a variable.

The number of arguments that are specified must be the same as the number of parameters of a procedure that is defined at the current server with the specified procedure name.

If USING DESCRIPTOR is specified, each variable described by the identified SQLDA is an argument, or part of an expression that is an argument of the CALL statement. If host structures are not specified

in the CALL statement, the *n*th argument of the CALL statement corresponds to the *n*th parameter in the stored procedure, and the number in each must be the same. Otherwise, each reference to a host structure is replaced by a reference to each of the variables contained in that host structure, and the resulting number of arguments must be the same as the number of parameters defined for the stored procedure.

However, a character FOR BIT DATA argument cannot be passed as input for a parameter that is not defined as character FOR BIT DATA. Likewise, a character argument that is not FOR BIT DATA cannot be passed as input for a parameter that is defined as character FOR BIT DATA.

The attributes of the parameters are determined by the current server. In addition to attributes such as data type and length, the description of each parameter indicates how the stored procedure uses it:

- IN means as an input value
- OUT means as an output value
- INOUT means both as an input and an output value

All parameters that are not variables are assumed to be input parameters (IN).

expression

The argument is the result of the specified expression, which is evaluated before the stored procedure is invoked.

If *expression* is a single variable, the corresponding parameter of the procedure can be defined as IN, INOUT, or OUT. Otherwise, the corresponding parameter of the procedure must be defined as IN. An expression can contain any of the following items:

- Variable
- Constant
- Special register
- Session global variable
- Cast function with a variable or constant argument

A variable can identify a structure. Any variable or structure that is specified must be described in the application program according to the rules for declaring host structures and variables. A reference to a host structure is replaced by a reference to each of the variables contained in the host structure.

If the result of the expression can be the null value, either the description of the procedure must allow for null parameters or the corresponding parameter of the stored procedure must be defined as OUT.

expression must not reference an associative array value as an argument to a function if the procedure is remote.

The following additional rules apply depending on how the corresponding parameter was defined in the CREATE PROCEDURE statement for the procedure:

- IN *expression* can contain references to multiple variables. In addition to the rules stated in “Expressions” on page 245 for *expression*, *expression* cannot include a column name, a scalar subselect, a file reference variable, an aggregate function, or a user-defined function that is sourced on an aggregate function.
- INOUT or OUT *expression* can only be a single variable. *expression* cannot include a file reference variable or an array element.

NULL

The parameter is a null value. The corresponding parameter of the procedure must be defined as IN and the description of the procedure must allow for null parameters.

TABLE *transition-table-name*

The parameter is a transition table, and it is passed to the procedure as a table locator. You can use the CALL statement with the TABLE clause only within the definition of the triggered

action of a trigger. The name of a transition table must be specified in the CALL statement if the corresponding parameter of the procedure was defined in the TABLE LIKE clause of the CREATE PROCEDURE statement. For information about creating a trigger, see [“CREATE TRIGGER statement \(basic trigger\)”](#) on page 1769 and [Creating a trigger \(Db2 Application programming and SQL\)](#).

There is no effect on the transition table on the return from the procedure regardless of whether the parameter was defined as IN, INOUT, or OUT, because transition tables are read-only.

USING DESCRIPTOR *descriptor-name*

Identifies an SQLDA that contains a valid description of the variables that are to be passed as parameters to the stored procedure. If the stored procedure has no parameters, an SQLDA is ignored.

Before the CALL statement is processed, the user must set the following fields in the SQLDA:

- SQLN to indicate the number of SQLVAR occurrences provided in the SQLDA. This number must not be less than SQLD. This field is not part of the REXX SQLDA and therefore does not need to be set for REXX programs.
- SQLDABC to indicate the number of bytes of storage allocated for the SQLDA. This number must not be less than SQLN*44+16. This field is not part of the REXX SQLDA and therefore does not need to be set for REXX programs.
- SQLD to indicate the number of variables used in the SQLDA when processing the statement. This number must be the same as the number of parameters of the stored procedure.
- SQLVAR occurrences to indicate the attributes of the variables.

There are additional considerations for setting the fields of the SQLDA when a variable that is passed as a parameter to the stored procedure has a LOB data type or is a LOB locator. For more information, see [Appendix G, “SQL descriptor area \(SQLDA\),”](#) on page 2313.

The SQL CALL statement ignores distinct type information in the SQLDA. Only the base SQL type information is used to process the input and output parameters described by the SQLDA.

In REXX, only *variables* USING DESCRIPTOR is supported. Since global variables are not supported within the SQLDA, global variables are not supported in REXX.

See [“Identifying an SQLDA in C or C++”](#) on page 2329 for how to represent *descriptor-name* in C.

Notes for CALL

Parameter assignments: When the CALL statement is executed, the value of each of its arguments is assigned with storage assignment rules to the corresponding IN or INOUT parameter of the stored procedure. In cases where the arguments of the CALL statement are not an exact match to the data types of the parameters of the stored procedure, each argument specified in the CALL statement is converted to the data type of the corresponding parameter of the stored procedure at execution. The conversion occurs according to the same rules as assignment to columns.

Control is passed to the stored procedure according to the calling conventions of the host language.

When execution of the stored procedure is complete, the value of each parameter of the stored procedure defined as OUT or INOUT is assigned to the corresponding argument of the CALL statement. If an error is returned by the procedure, OUT arguments are undefined, and INOUT arguments are unchanged.

A timestamp without time zone value must not be assigned to a timestamp with time zone target.

The following rules apply when the value of an array argument is assigned to the corresponding array parameter:

- **For a local procedure call:** The argument and the parameter must be defined as the same array type.
- **For a remote procedure call:** The data type of the elements of the array argument must be the same as the data type of the elements of the array parameter. In addition, for IN or OUT parameters, all of the relevant conditions in one of the rows in the following table must be true. For INOUT parameters, all of

the relevant conditions in row 1 of the following table must be true, or all of the relevant conditions in rows 2 and 3 must be true. A relevant condition is indicated with Y.

Relationship of argument to associated parameter	Relationship applies to IN parameter	Relationship applies to OUT parameter	Relationship applies to INOUT parameter
The argument is an ordinary array, the parameter is an ordinary array, and the argument and parameter are defined with the same data type for the array indexes.	Y	Y	Y
The argument is an ordinary array, the parameter is an associative array type, the parameter is an IN or INOUT parameter, and the data type of the array indexes is INTEGER. The associative array parameter is assigned an associative array value that is derived from the ordinary array argument value. The values of the array elements in the ordinary array are assigned to the target associative array parameter, in the same order as their order in the ordinary array argument. The index values in the target associative array parameter are assigned from 1 to the cardinality of the ordinary array argument value.	Y		Y
The argument is an ordinary array type, the parameter is an associative array type, and the parameter is an INOUT or OUT parameter. The argument is assigned an ordinary array value that is derived from the associative array parameter value. The values of the array elements in the associative array value are assigned to the target ordinary array, in an order determined by Db2. The index values in the target ordinary array argument are assigned from 1 to the cardinality of the associative array parameter value. The index values from the associative array parameter value are ignored.		Y	Y

For details on the rules used to assign parameters, see [“Assignment and comparison”](#) on page 143.

Conversion can occur when precision, scale, length, encoding scheme, or CCSID differ between the argument specified in the CALL statement and the data type of the corresponding parameter of the stored procedure. Conversion might occur for a character string argument specified in the CALL statement when the corresponding parameter of the stored procedure has a different encoding scheme or CCSID. For example, an error occurs when the CALL statement passes an argument of mixed data that actually contains DBCS characters as input for a parameter of the stored procedure that is defined as FOR SBCS DATA. Likewise, an error occurs when the stored procedure returns mixed data that actually contains DBCS characters for an argument of the CALL statement that is defined as FOR SBCS DATA.

Procedure signatures: A procedure is identified by its schema, a procedure name, and its number of parameters. This is called a procedure signature, which must be unique within the database. Db2 for z/OS does not support overloaded procedure names (procedures with the same schema and procedure name, but with different numbers of parameters).

SQL path: A procedure can be invoked by referring to a qualified name (schema and procedure name), followed by an optional list of arguments that are enclosed in parentheses. A procedure can also be invoked without the schema name, which results in a choice of possible procedures in different schemas that have the same procedure name and same number of parameters. In this case, the SQL path is used to assist in procedure resolution. The SQL path is a list of schemas that is searched to identify a procedure with the same name and number of parameters as the procedure in the CALL statement. For CALL statements that explicitly specify a procedure name, the SQL path is specified by using the platform-specific bind option. For CALL *variable* statements, the SQL path is the value of the CURRENT PATH special register when the procedure is invoked.

Procedure resolution: Given a procedure invocation, the database manager must decide which of the possible procedures that has the same name to call.

A procedure name is a qualified or unqualified name. Each part of the name must be composed of SBCS characters:

- A fully qualified procedure name is a three-part name. The first part is an SQL identifier that contains the location name that identifies the DBMS at which the procedure is stored. The second part is an SQL identifier that contains the schema name of the stored procedure. The last part is an SQL identifier that contains the name of the stored procedure. A period must separate each of the parts. Any or all of the parts can be a delimited identifier.
- A two-part procedure name has one implicit qualifier. The implicit qualifier is the location name of the current server. The two parts identify the schema name and the name of the stored procedure. A period must separate the two parts.
- An unqualified procedure name is a one-part name with two implicit qualifiers. The first implicit qualifier is the location name of the current server. The second implicit qualifier depends on the server. If the server is Db2 for z/OS, the implicit qualifier is the schema name. Db2 uses the SQL path to determine the value of the schema name.
 - If the procedure name is specified as a string constant on the CALL statement (CALL *procedure-name*), the SQL path is the value of the PATH bind option that is associated with the calling package or plan.
 - If a variable is specified for the procedure name on the CALL statement (CALL *variable*), the SQL path is the value of the CURRENT PATH special register.

Db2 searches the schema names in the SQL path from left to right until a stored procedure with the specified schema name is found in the Db2 catalog. When a matching *schema.procedure-name* is found, the search stops only if the following conditions are true:

- The user is authorized to call the stored procedure.
- The number of parameters in the definition of the stored procedure matches the number of parameters specified on the CALL statement.

If the list of schemas in the SQL path is exhausted before the procedure name is resolved, an error is returned.

When the procedure is resolved depends on how the procedure name is specified. For a CALL statement that specifies the procedure name using a variable, procedure resolution occurs at run time. For a CALL statement that contains the name of the procedure as an identifier, procedure resolution occurs when the CALL statement is bound.

Procedure resolution is done by the database manager using the following steps:

1. Find all procedures from the catalog where all of the following conditions are true:
 - For invocations where the schema name is specified (qualified references), the schema name and the procedure name match the invocation name.

For invocations where the schema name is not specified (unqualified references), the procedure name matches the invocation name, and the procedure has a schema name that matches one of the schemas in the SQL path.

- The number of defined parameters matches the number of arguments that are specified in the invocation.
 - The invoker has the EXECUTE privilege on the procedure.
2. Of the candidate procedures that remain from step 1, choose the procedure whose schema is first in the SQL path. If no candidate procedures remain after step 1, an error is returned.
 3. For CALL statements that use a variable to specify the procedure name, the CURRENT ROUTINE VERSION special register can affect which version of the native SQL procedure is invoked. If the CURRENT ROUTINE VERSION special register is set, check if there is a version of the procedure with that version name. If not, choose the currently active version of the procedure.

For CALL statements that do not use a variable to specify the procedure name, choose the currently active version of the procedure.

Version resolution: Normally, the currently active version of a native SQL procedure will be used on a CALL statement. However, if the CALL statement is a recursive call inside the body of the same stored procedure, and the original CALL statement uses a version that is different from the currently active version, the active version will not be used. The version from the original CALL statement will be used for any recursive CALL statements until the entire stored procedure finishes executing. This preserves the semantics of the version that is used by the original CALL statement. This includes the case where the recursive call is indirect. For example, assume that procedure SP1 call procedure SP2, which in turn recursively calls SP1. The second invocation of procedure SP1 will use the version of the procedure that is active at the time of the original CALL statement that invoked procedure SP1.

Since the currently active version can be used at the next CALL statement, it is possible that two or more versions of the same procedure can run at the same time. There could be different versions of an SQL procedure loaded by a given thread. For example, a CALL SP1 statement in an application will cause the currently active version, SP1_V1, to load and execute. After this CALL statement has completed, an ALTER PROCEDURE ALTER ACTIVE VERSION could execute and change the active version of the procedure SP1 to version SP1_V2. Subsequent CALL SP1 statements from the same thread will load the currently active version of the procedure, SP1_V2, and execute it.

Parameter assignments: When the CALL statement is executed, the value of each of its parameters is assigned with storage assignment rules to the corresponding parameter of the procedure. Control is passed to the procedure according to the calling conventions of the host language. When execution of the procedure is complete, the value of each parameter of the procedure is assigned with storage assignment rules to the corresponding parameter of the CALL statement defined as OUT or INOUT. If an error is returned by the procedure, OUT arguments are undefined and INOUT arguments are unchanged. For details on the assignment rules, see [“Assignment and comparison” on page 143](#).

Cursors and prepared statements in procedures: All cursors opened in the called procedure that are not result set cursors are closed and all statements prepared in the called procedure are destroyed when the procedure ends.

Result sets from procedures: Any cursors specified using the WITH RETURN clause that the procedure leaves open when it returns identifies a result set. In a procedure written in Java, all cursors are implicitly defined WITH RETURN.

Results sets are returned only when the procedure is called from CLI, JDBC, or SQLJ. If the procedure was invoked from CLI or Java, and more than one cursor is left open, the result sets can only be processed in the order in which the cursors were opened. Only unread rows are available to be fetched. For example, if the result set of a cursor has 500 rows, and 150 of those rows have been read by the procedure at the time the procedure is terminated, then rows 151–500 will be returned to the procedure.

Errors from procedures: A procedure can return errors or warnings using an SQLSTATE like other SQL statements. Applications should be aware of the possible SQLSTATES that can be expected when a procedure is invoked. The possible SQLSTATES depend on how the procedure is coded. Procedures might also return SQLSTATES such as those that begin with '38' or '39' if Db2 encounters problems executing

the procedure. Applications should therefore be prepared to handle any error SQLSTATE that can result from issuing a CALL statement.

Improving performance: The capability of calling stored procedures is provided to improve the performance of DRDA distributed access. The capability is also useful for local operations. The server can be the local Db2. In which case, packages are still required.

All values of all parameters are passed from the requester to the server. To improve the performance of this operation, variables that correspond to OUT parameters and have lengths of more than a few bytes should be set to null before the CALL statement is executed.

Using the CALL statement in a trigger: When a trigger issues a CALL statement to invoke a stored procedure, the parameters that are specified in the CALL statement cannot be variables and the USING DESCRIPTOR clause cannot be specified.

Nesting CALL statements: A program that is executing as a stored procedure, a user-defined function, or a trigger can issue a CALL statement. When a stored procedure, user-defined function, or trigger calls a stored procedure, user-defined function, or trigger, the call is considered to be nested. Stored procedures, user-defined functions, and triggers can be nested up to 64 levels deep on a single system. Nesting can occur within a single Db2 subsystem or when a stored procedure or user-defined function is invoked at a remote server.

If a stored procedure returns any query result sets, the result sets are returned to the caller of the stored procedure. If the SQL CALL statement is nested, the result sets are visible only to the program that is at the previous nesting level. For example, [Figure 31 on page 1393](#) illustrates a scenario in which a client program calls stored procedure PROCA, which in turn calls stored procedure PROCB. Only PROCA can access any result sets that PROCB returns; the client program has no access to the query result sets. The number of query result sets that PROCB returns does not count toward the maximum number of query results that PROCA can return.

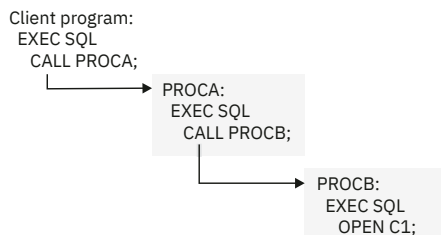

Figure 31. Nested CALL statements

Some stored procedures cannot be nested. A stored procedure, user-defined function, or trigger cannot call a stored procedure that is defined with the COMMIT ON RETURN attribute. Procedures that are defined with the AUTONOMOUS attribute cannot call other procedures that are defined with the AUTONOMOUS attribute.

Multiple calls to the same stored procedure: You can call a stored procedure multiple times within an application and at the same nesting level. Each call to the same stored procedure causes a unique instance of the stored procedure to run. If the stored procedure returns result sets, each instance of the stored procedure opens its own set of result set cursors.

The application might receive a "resource unavailable message" if the CALL statement causes the values of the maximum number of active stored procedures or maximum number open cursors to be exceeded. The value of field MAX STORED PROCEDURES (on installation panel DSNTIPX) defines the maximum number of active stored procedures that are allowed per thread. The value of field MAX OPEN CURSORS (on installation panel DSNTIPX) defines the maximum number of open cursors (both result set cursors and regular cursors) that are allowed per thread.

If you make multiple calls to the same stored procedure within an application, be aware of the following considerations:

- A DESCRIBE PROCEDURE statement describes the last instance of the stored procedure.
- The ASSOCIATE LOCATORS statement works on the last instance of the stored procedure.

- The ALLOCATE CURSOR statement must specify a unique cursor name for a result set returned from an instance of the stored procedure. Otherwise, you will lose the data from the result sets that are returned from prior instances or calls to the stored procedure.

You should issue an ASSOCIATE LOCATORS statement (or DESCRIBE PROCEDURE statement) after each call to the stored procedure to get a unique locator value for each result set.

Using variables: If the CALL statement contains variables, the contents of the variables are assumed to be in the encoding scheme that was specified in the ENCODING parameter when the package or plan that contains the statement was bound.

Examples for CALL

Example 1: A PL/I application has been precompiled on Db2 ALPHA and a package was created at Db2 BETA with the BIND subcommand. A CREATE PROCEDURE statement was issued at BETA to define the procedure SUMARIZE, which allows nulls and has two parameters. The first parameter is defined as IN and the second parameter is defined as OUT. Some of the statements that the application that runs at Db2 ALPHA might use to call stored procedure SUMARIZE include:

```
EXEC SQL CONNECT TO BETA;
V1 = 528671;
IV = -1;
EXEC SQL CALL SUMARIZE(:V1,:V2 INDICATOR :IV);
```

Example 2: Suppose that stored procedure MYPROC exists and produces several result sets. An application might include statements like the following to access the result sets produced by MYPROC:

```
-- Invoke stored procedure MYPROC that returns several result sets
EXEC SQL CALL MYPROC (...);
-- Copy the locator values for the result sets into result set locator variables
EXEC SQL ASSOCIATE RESULT SET LOCATORS (:RS1, :RS2, :RS3) WITH PROCEDURE MYPROC;
-- Allocate cursors for the result set cursors
EXEC SQL ALLOCATE CSR1 CURSOR FOR RESULT SET :RS1;
EXEC SQL ALLOCATE CSR2 CURSOR FOR RESULT SET :RS2;
EXEC SQL ALLOCATE CSR3 CURSOR FOR RESULT SET :RS3;
-- Process data returned with the result set cursors
DO WHILE (SQLCODE = 0);
EXEC SQL FETCH CSR1 INTO .....
END;
EXEC SQL CLOSE CSR1;
-- do similar processing with other result sets
...
```

Example 3: Suppose that procedure FIND_CUSTOMERS has the following parameters:

- An IN parameter that is an array of phone numbers
- An IN parameter that is a prefix value to search for a match
- An OUT parameter that returns an array of phone numbers

FIND_CUSTOMERS searches the input array variable for phone numbers that match the prefix value, and returns an array that contains the phone numbers that match the prefix value.

The input and output array variables are defined as follows:

```
CREATE TYPE PHONENUMBERS AS VARCHAR(20) CCSID UNICODE ARRAY[10];
-- Create an array type
CREATE VARIABLE PNUMBER_ARRAY PHONENUMBERS; -- Create input array variable
CREATE VARIABLE PNUMBER_ARRAY_OUT PHONENUMBERS;
-- Create output array variable
```

FIND_CUSTOMERS looks like this:

```
-----
-- Create an SQL procedure with array parameters. The array parameters are
-- defined with the PHONENUMBERS array type. The procedure searches for
```

```

-- numbers in IN_PHONENUMBERS that begin with the given prefix, and returns
-- the phone numbers in the NUMBERS_OUT parameter.
-----
CREATE PROCEDURE FIND_CUSTOMERS(
  IN NUMBERS_IN PHONENUMBERS,
  IN PREFIX CHAR(3),
  OUT NUMBERS_OUT PHONENUMBERS)
BEGIN
  DECLARE I, J INTEGER;

  SET I = 1;
  SET J = 1;

  -- Initialize NUMBERS_OUT to an empty array using an array constructor
  -- with no elements
  SET NUMBERS_OUT = ARRAY[ ];
  WHILE i < CARDINALITY(NUMBERS_IN) DO
    IF SUBSTR(NUMBERS_IN[I], 1, 3) = PREFIX THEN
      SET NUMBERS_OUT[J] = NUMBERS_IN[I];
      SET J = J + 1;
    END IF;
    SET I = I + 1;
  END WHILE;
END %

```

In the client program, initialize the input array with values from an array constructor, and then invoke the procedure:

```

SET PNUMBER_ARRAY = ARRAY['416-305-3745',
                          '905-414-4565',
                          '416-305-3746'];
CALL FIND_CUSTOMERS(PNUMBER_ARRAY,      -- NUMBERS_IN parameter (IN parm)
                   '416',              -- PREFIX parameter (IN parm)
                   PNUMBER_ARRAY_OUT); -- NUMBERS_OUT parameter (OUT parm)

```

The CALL statement returns an array value with the following information in the argument corresponding to the NUMBERS_OUT parameter, which sets the PNUMBER_ARRAY_OUT variable:

```

['416-305-3745',
 '416-305-3746']

```

CLOSE statement

The CLOSE statement closes a cursor. If a temporary copy of a result table was created when the cursor was opened, that table is destroyed.

Invocation for CLOSE

This statement can only be embedded in an application program. It is an executable statement that cannot be dynamically prepared. It must not be specified in Java.

Authorization for CLOSE

See “[DECLARE CURSOR statement](#)” on page 1819 for the authorization required to use a cursor.

Syntax for CLOSE

```

▶▶ CLOSE — cursor-name ▶▶

```

Description for CLOSE

cursor-name

Identifies the cursor to be closed. The cursor name must identify a declared cursor as explained in “[DECLARE CURSOR statement](#)” on page 1819. When the CLOSE statement is executed, the cursor must be in the open state.

Notes for CLOSE

Implicit cursor close: At the end of a unit of work, all open cursors declared without the WITH HOLD option that belong to an application process are implicitly closed.

Close cursors for performance: Explicitly closing cursors as soon as possible can improve performance.

Procedure considerations: Special rules apply to cursors within procedures that have not been closed before returning to the calling program. For more information, see [“CALL statement” on page 1384](#).

Allocated cursors: The cursor could have been allocated. See [“ALLOCATE CURSOR statement” on page 1093](#).

Example for CLOSE

A cursor is used to fetch one row at a time into the application program variables DNUM, DNAME, and MNUM. Finally, the cursor is closed. If the cursor is reopened, it is again located at the beginning of the rows to be fetched.

```
EXEC SQL DECLARE C1 CURSOR FOR
  SELECT DEPTNO, DEPTNAME, MGRNO
  FROM DSN8C10.DEPT
  WHERE ADMRDEPT = 'A00'
  END-EXEC.

EXEC SQL OPEN C1 END-EXEC.

EXEC SQL FETCH C1 INTO :DNUM, :DNAME, :MNUM END-EXEC.

IF SQLCODE = 100
  PERFORM DATA-NOT-FOUND
ELSE
  PERFORM GET-REST-OF-DEPT
  UNTIL SQLCODE IS NOT EQUAL TO ZERO.

EXEC SQL CLOSE C1 END-EXEC.

GET-REST-OF-DEPT.
EXEC SQL FETCH C1 INTO :DNUM, :DNAME, :MNUM END-EXEC.
```

COMMENT statement

The COMMENT statement adds or replaces comments in the descriptions of various objects in the Db2 catalog at the current server.

Invocation for COMMENT

This statement can be embedded in an application program or issued interactively. It is an executable statement that can be dynamically prepared.

Authorization for COMMENT

For a comment on the following objects, the privilege set must include at least one of the listed authorities or privileges:

Table, view, index, column, or alias for a table or view:

- Ownership of the table, view, alias, or index
- DBADM authority for its database (tables and indexes only)
- SYSADM or SYSCTRL authority
- System DBADM
- SECADM authority (if the table has an activated row permission or column access control)

If the database is implicitly created, the database privileges must be on the implicit database or on DSNDB04.

User-defined type, global variable, stored procedure, trigger, or user-defined function:

- Ownership of the object
- The ALTERIN privilege on the schema (for the addition of comments)
- SYSADM or SYSCTRL authority
- System DBADM

Secure trigger or secure user-defined function:

- SECADM authority
- CREATE_SECURE_OBJECT privilege

Package:

- Ownership of the package
- The BINDAGENT privilege granted from the package owner
- PACKADM authority for the collection or for all collections
- SYSADM or SYSCTRL authority
- System DBADM

Role or a trusted context:

- Ownership of the object
- SYSADM or SYSCTRL authority
- SECADM

If the installation parameter SEPARATE SECURITY is NO, SYSADM authority has implicit SECADM and SYSCTRL authority and can drop a role or trusted context.

Sequence or alias for a sequence:

- Ownership of the sequence
- The ALTER privilege for the sequence if the target is a sequence
- The ALTERIN privilege on the schema
- SYSADM or SYSCTRL authority
- System DBADM

The authorization ID that matches the schema name implicitly has the ALTERIN privilege on the schema.

Row permission or column mask:

SECADM authority

Privilege set: If the statement is embedded in an application program, the privilege set is the privileges that are held by the owner of the plan or package. If the statement is dynamically prepared, the privilege set is determined by the DYNAMICRULES behavior in effect (run, bind, define, or invoke) and is summarized in [“Dynamic preparation and execution” on page 1088](#). (For more information on these behaviors, including a list of the DYNAMICRULES bind option values that determine them, see [“Authorization IDs and dynamic SQL” on page 94](#).)

Syntax for COMMENT

COMMENT ON →

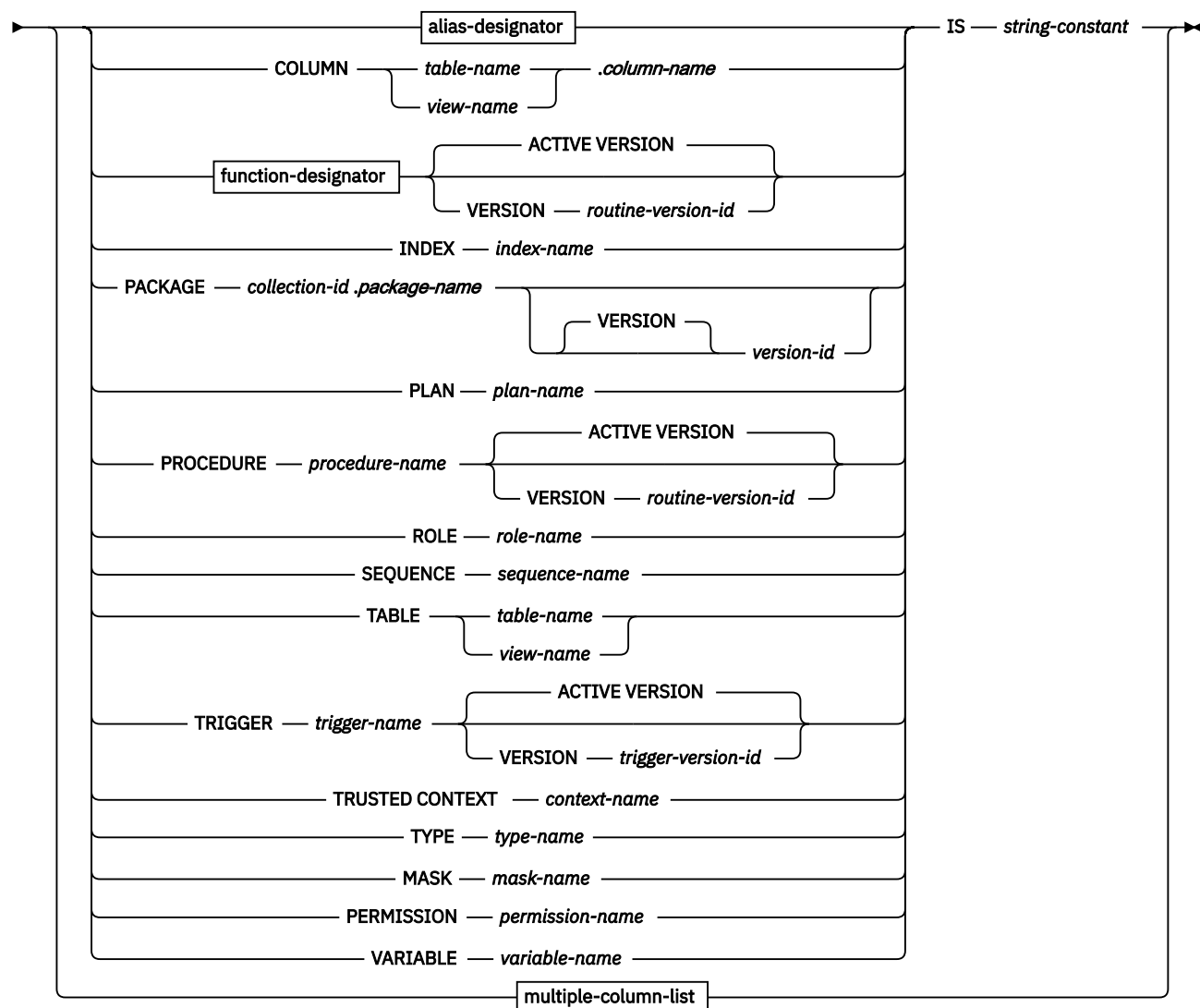

alias-designator



Notes:

¹ If **PUBLIC** is specified, **FOR SEQUENCE** must also be specified.

multiple-column-list

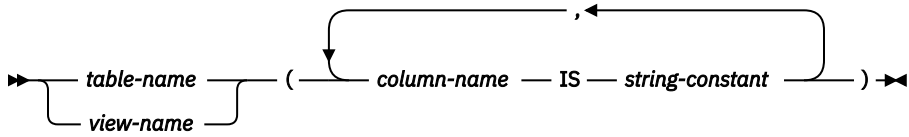

function-designator

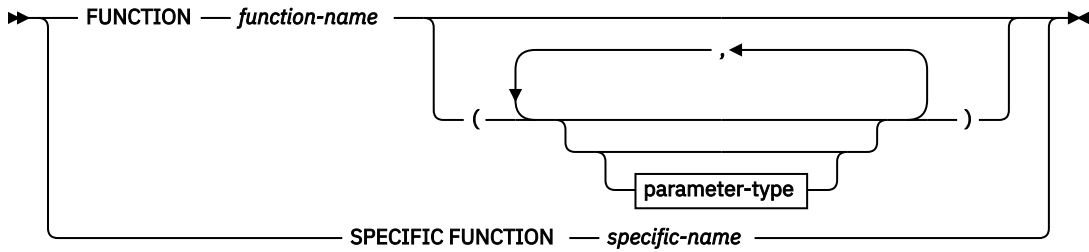

parameter-type



Notes:

¹ AS LOCATOR can be specified only for a LOB data type or a distinct type that is based on a LOB data type.

data-type

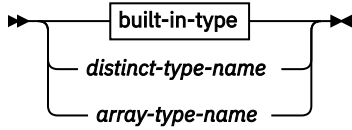

built-in-type

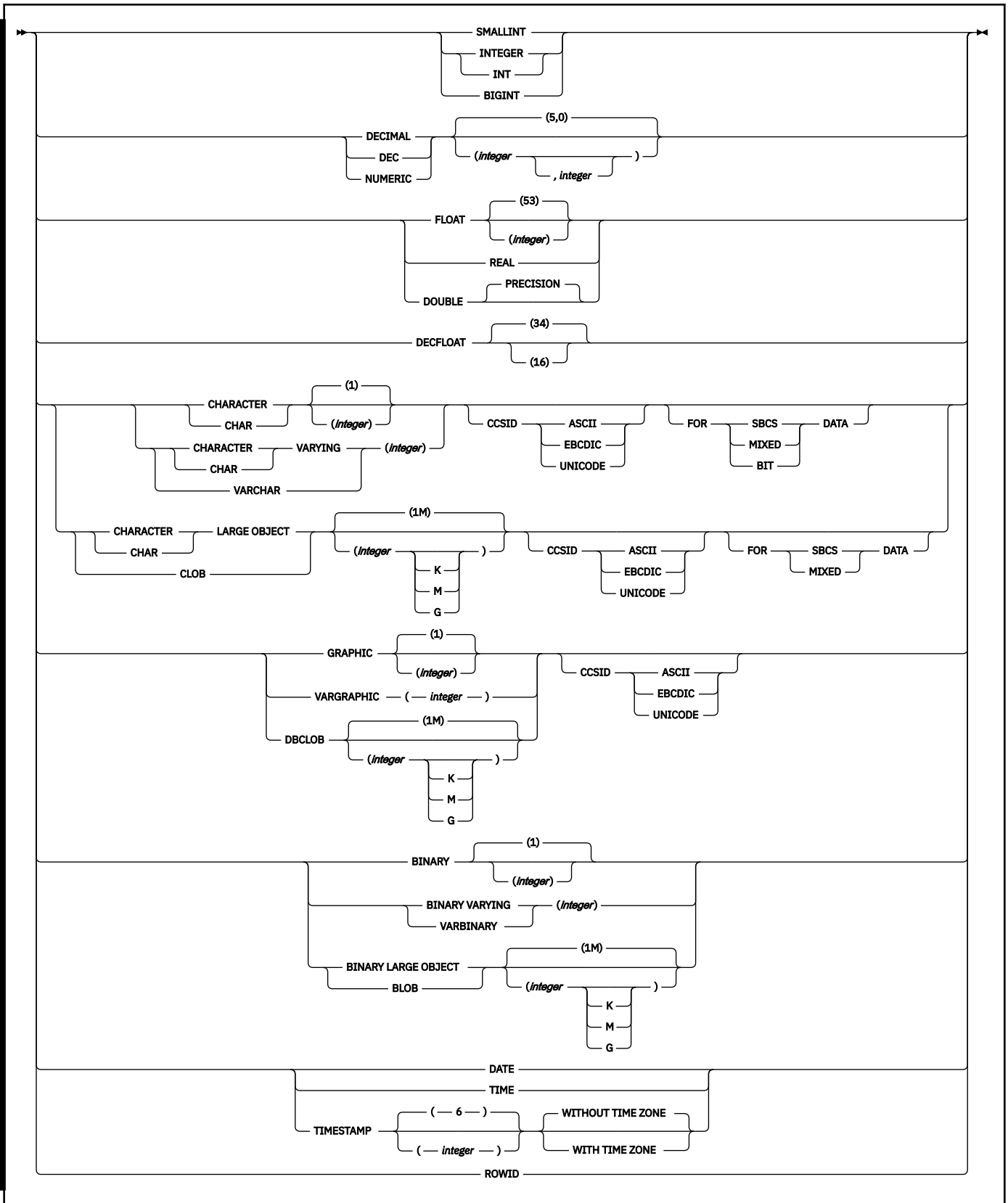

Description for COMMENT

alias-designator

ALIAS *alias-name*

Indicates a comment will be added or replaced for an alias. The name must identify an alias that exists at the current server.

If the PUBLIC keyword is specified, *alias-name* must identify a public alias that exists at the current server. The comment is applied to a public alias.

FOR TABLE

Specifies that the alias is for a table or a view. The comment replaces the value of the REMARKS column of the SYSIBM.SYSTABLES catalog table for the row that describes the alias.

FOR SEQUENCE

Specifies that the alias is for a sequence. The comment replaces the value of the REMARKS column of the SYSIBM.SYSSEQUENCES catalog table for the row that describes the alias.

COLUMN *table-name.column-name* or *view-name.column-name*

Identifies the column to which the comment applies. The name must identify a column of a table or view that exists at the current server. The name must not identify a column of a declared temporary table. The comment is placed into the REMARKS column of the SYSIBM.SYSCOLUMNS catalog table, for the row that describes the column.

Do not use TABLE or COLUMN to comment on more than one column in a table or view. Give the table or view name and then, in parentheses, a list in the form:

```
column-name IS string-constant,  
column-name IS string-constant,...
```

The column names must not be qualified, each name must identify a column of the specified table or view, and that table or view must exist at the current server.

FUNCTION or SPECIFIC FUNCTION

Identifies the function to which the comment applies. The function must exist at the current server, and it must be a function that was defined with the CREATE FUNCTION statement or a cast function that was generated by a CREATE TYPE statement. The comment is placed in the REMARKS column of the SYSIBM.SYSROUTINES catalog table for the row that describes the function.

The function can be identified by its name, function signature, or specific name. If the function was defined with a table parameter (the LIKE TABLE was specified in the CREATE FUNCTION statement to indicate that one of the input parameters is a transition table), you must identify the function with its function name, if it is unique, or with its specific name.

FUNCTION *function-name*

Identifies the function by its function name. There must be exactly one function with *function-name* in the schema. The function can have any number of input parameters. If the schema does not contain a function with *function-name*, or if the schema contains more than one function with this name, an error is returned.

FUNCTION *function-name (parameter-type,...)*

Identifies the SQL function by its function signature, which uniquely identifies the function. A function with the function signature must exist in the explicitly or implicitly specified schema.

If *function-name()* is specified, the function that is identified must have zero parameters.

function-name

Identifies the name of the function. If the function was defined with a table parameter (the LIKE TABLE *name* AS LOCATOR clause was specified in the CREATE FUNCTION statement to indicate that one of the input parameters is a transition table), the function signature cannot be used to uniquely identify the function. Instead, use one of the other syntax variations to identify the function with its function name, if unique, or with its specific name.

(parameter-type,...)

Specifies the number of input parameters of the function and the name and data type of each parameter.

(data-type,...)

Identifies the number of input parameters of the function and the data type of each parameter. The data type of each parameter must match the data type that was specified in the CREATE FUNCTION statement for the parameter in the corresponding position. The number of data types and the logical concatenation of the data types are used to uniquely identify the function.

For data types that have a length, precision, or scale attribute, you can use a set of empty parentheses, specify a value, or accept the default values:

- Empty parentheses indicate that Db2 is to ignore the attribute when determining whether the data types match.

For example, DEC() will be considered a match for a parameter of a function defined with a data type of DEC(7,2). Similarly DECFLOAT() will be considered a match for DECFLOAT(16) or DECFLOAT(34).

FLOAT cannot be specified with empty parentheses because its parameter value indicates different data types (REAL or DOUBLE).

- If you use a specific value for a length, precision, or scale attribute, the value must exactly match the value that was specified (implicitly or explicitly) in the CREATE FUNCTION statement.

The specific value for FLOAT(*n*) does not have to exactly match the defined value of the source function because $1 \leq n \leq 21$ indicates REAL and $22 \leq n \leq 53$ indicates DOUBLE. Matching is based on whether the data type is REAL or DOUBLE.

- If length, precision, or scale is not explicitly specified and empty parentheses are not specified, the default length of the data type is implied. The implicit length must exactly match the value that was specified (implicitly or explicitly) in the CREATE FUNCTION statement.

For data types with a subtype or encoding scheme attribute, specifying the FOR *subtype* DATA clause or the CCSID clause is optional. Omission of either clause indicates that Db2 is to ignore the attribute when determining whether the data types match. If you specify either clause, it must match the value that was implicitly or explicitly specified in the CREATE FUNCTION statement.

AS LOCATOR

Specifies that the function is defined to receive a locator for this parameter. If AS LOCATOR is specified, the data type must be a LOB or a distinct type based on a LOB.

SPECIFIC FUNCTION *specific-name*

Identifies a particular user-defined function by its specific name. The name is implicitly or explicitly qualified with a schema name. A function with the specific name must exist in the schema. If the specific name is not qualified, it is implicitly qualified with a schema name as described in the description for FUNCTION *function-name*.

ACTIVE VERSION

Specifies that the comment applies to the currently active version of the routine that is specified by *function-name*.

ACTIVE VERSION is the default.

VERSION *routine-version-id*

Specifies that the comment applies only to the version of the routine that is identified by *routine-version-id*. *routine-version-id* must identify a version of the specified routine that already exists at the current server.

INDEX *index-name*

Identifies the index to which the comment applies. *index-name* must identify an index that exists at the current server. The comment is placed in the REMARKS column of the SYSIBM.SYSINDEXES catalog table for the row that describes the index.

MASK *mask-name*

Identifies the column mask to which the comment applies. *mask-name* must identify a column mask that exists at the current server. The comment is placed in the REMARKS column of the SYSIBM.SYSCONTROLS catalog table for the row that describes the column mask.

PACKAGE *collection-id.package-name*

Identifies the package to which the comment applies. You must qualify the package name with a collection ID. *collection-id.package-name* must identify a package that exists at the current server. The name plus the implicitly or explicitly specified *version-id* must identify a package that exists at the current server. Omission of the *version-id* is an implicit specification of the null version.

The name must not identify a trigger package or a package that is associated with an SQL routine. Specify this clause to comment on a package that was created as the result of a BIND COPY command used to deploy a version of a native SQL procedure.

VERSION *version-id*

version-id is the version identifier that was assigned to the package's DBRM when the DBRM was created. If *version-id* is not specified, a null version is used as the version identifier.

Delimit the version identifier when it:

- Is generated by the VERSION(AUTO) precompiler option
- Begins with a digit
- Contains lowercase or mixed-case letters

For more on version identifiers, see the information on preparing an application program for execution in [Creating a package version \(Db2 Application programming and SQL\)](#).

PERMISSION *permission-name*

Identifies the row permission to which the comment applies. *permission-name* must identify a row permission that exists at the current server. The comment is placed in the REMARKS column of the SYSIBM.SYSCONTROLS catalog table for the row that describes the row permission.

PLAN *plan-name*

Identifies the plan to which the comment applies. *plan-name* must identify a plan that exists at the current server.

PROCEDURE *procedure-name*

Identifies the procedure to which the comment applies. *procedure-name* must identify a procedure that exists at the current server.

ACTIVE VERSION

Specifies that the comment applies to the currently active version of the routine that is specified by *procedure-name*.

ACTIVE VERSION is the default.

VERSION *routine-version-id*

Specifies that the comment applies only to the version of the routine that is identified by *routine-version-id*. *routine-version-id* must identify a version of the specified routine that already exists at the current server.

ROLE *role-name*

Identifies the role to which the comment applies. *role-name* must identify a role that exists at the current server. The comment is placed in the REMARKS column of the SYSIBM.SYSROLES catalog table for the row that describes the role.

SEQUENCE *sequence-name*

Identifies the sequence to which the comment applies.

sequence-name must identify a sequence that exists at the current server. *sequence-name* must not be the name of an internal sequence object that is used by Db2. The comment is placed in the REMARKS column of the SYSIBM.SYSSEQUENCES catalog table for the row that describes the sequence.

TABLE *table-name* or *view-name*

Identifies the table or view to which the comment applies. *table-name* or *view-name* must identify a table, auxiliary table, or view that exists at the current server. *table-name* must not identify a declared temporary table. The comment is placed in the REMARKS column of the SYSIBM.SYSTABLES catalog table for the row that describes the table or view.

TRIGGER *trigger-name*

Identifies the trigger to which the comment applies. *trigger-name* must identify a trigger that exists at the current server. The comment is placed in the REMARKS column of the SYSIBM.SYSTRIGGERS catalog table for the row that describes the trigger or version of the trigger.

ACTIVE VERSION

Specifies that the comment applies to the currently active version of the trigger that is specified by *trigger-name*.

ACTIVE VERSION is the default.

ACTIVE VERSION must only be specified for an advanced trigger.

VERSION *trigger-version-id*

Specifies that the comment applies only to the version of the trigger that is identified by *trigger-version-id*. *trigger-version-id* must identify a version of the specified trigger that already exists at the current server.

VERSION must only be specified for an advanced trigger.

TRUSTED CONTEXT *context-name*

Identifies the trusted context to which the comment applies. *context-name* must identify a trusted context that exists at the current server. The comment is placed in the REMARKS column of the SYSIBM.SYSCONTEXT catalog table for the row that describes the trusted context.

TYPE *type-name*

Identifies the user-defined type to which the comment applies. *type-name* must identify a user-defined type that exists at the current server. The comment is placed in the REMARKS column of the SYSIBM.SYSDATATYPES catalog table for the row that describes the user-defined type.

VARIABLE *variable-name*

Identifies the global variable to which the comment applies. *variable-name* must identify a global variable that exists at the current server. *variable-name* must not identify a built-in global variable.

IS *string-constant*

Introduces the comment that you want to make. *string-constant* can be any SQL character string constant of up to 762 bytes.

multiple-column-list

To comment on more than one column in a table or view with a single COMMENT statement, specify the table or view name, followed by a list in parentheses of the form:

```
(column-name IS string-constant,  
column-name IS string-constant,  
...)
```

Each column name must not be qualified, and must identify a column of the specified table or view that exists at the current server.

Notes for COMMENT

Alternative syntax and synonyms:

To provide compatibility with previous releases of Db2 or other products in the Db2 family, Db2 supports the following syntax alternatives:

- DATA TYPE or DISTINCT TYPE as a synonym for TYPE
- COMMENT ON ALIAS SYSPUBLIC.*name* can be specified as an alternative to COMMENT ON PUBLIC ALIAS SYSPUBLIC.*name*

Examples for COMMENT

Example 1: Enter a comment on table DSN8C10.EMP.

```
COMMENT ON TABLE DSN8C10.EMP
IS 'REFLECTS 1ST QTR 81 REORG';
```

Example 2: Enter a comment on view DSN8C10.VDEPT.

```
COMMENT ON TABLE DSN8C10.VDEPT
IS 'VIEW OF TABLE DSN8C10.DEPT';
```

Example 3: Enter a comment on the DEPTNO column of table DSN8C10.DEPT.

```
COMMENT ON COLUMN DSN8C10.DEPT.DEPTNO
IS 'DEPARTMENT ID - UNIQUE';
```

Example 4: Enter comments on the two columns in table DSN8C10.DEPT.

```
COMMENT ON DSN8C10.DEPT
(MGRNO IS 'EMPLOYEE NUMBER OF DEPARTMENT MANAGER',
ADMNDEPT IS 'DEPARTMENT NUMBER OF ADMINISTERING DEPARTMENT');
```

Example 5: Assume that you are SMITH and that you created the distinct type DOCUMENT in schema SMITH. Enter comments on DOCUMENT.

```
COMMENT ON TYPE DOCUMENT
IS 'CONTAINS DATE, TABLE OF CONTENTS, BODY, INDEX, and GLOSSARY';
```

Example 6: Assume that you are SMITH and you know that ATOMIC_WEIGHT is the only function with that name in schema CHEM. Enter comments on ATOMIC_WEIGHT.

```
COMMENT ON FUNCTION CHEM.ATOMIC_WEIGHT
IS 'TAKES ATOMIC NUMBER AND GIVES ATOMIC WEIGHT';
```

Example 7: Assume that you are SMITH and that you created the function CENTER in schema SMITH. Enter comments on CENTER, using the signature to uniquely identify the function instance.

```
COMMENT ON FUNCTION CENTER (INTEGER, FLOAT)
IS 'USES THE CHEBYCHEV METHOD';
```

Example 8: Assume that you are SMITH and that you created another function named CENTER in schema JOHNSON. You gave the function the specific name FOCUS97. Enter comments on CENTER, using the specific name to identify the function instance.

```
COMMENT ON SPECIFIC FUNCTION JOHNSON.FOCUS97
IS 'USES THE SQUARING TECHNIQUE';
```

Example 9: Assume that you are SMITH and that procedure OSMOSIS is in schema BIOLOGY. Enter comments on OSMOSIS. Your comments will apply to the currently active version of the procedure OSMOSIS.

```
COMMENT ON PROCEDURE BIOLOGY.OSMOSIS
IS 'CALCULATIONS THAT MODEL OSMOSIS';
```

Example 11: Assume that you are SMITH and that trigger BONUS is in your schema. Enter comments on BONUS.

```
COMMENT ON TRIGGER BONUS
IS 'LIMITS BONUSSES TO 10% OF SALARY';
```

Example 12: Provide a comment for package MYPKG, which is in collection COLLIDA.

```
COMMENT ON COLLIDA.MYPKG
IS 'THIS IS MY PACKAGE';
```

Example 14: Provide a comment on role ROLE1:

```
COMMENT ON ROLE ROLE1
IS 'Role defined for trusted context, ctx1';
```

Example 15: Provide a comment on trusted context CTX1:

```
COMMENT ON TRUSTED CONTEXT CTX1
IS 'WEBSPPHERE SERVER';
```

Example 15: Provide a comment on column mask M1:

```
COMMENT ON MASK M1
IS 'Column mask for column EMP.SALARY';
```

COMMIT statement

The COMMIT statement ends the unit of recovery in which it is executed and a new unit of recovery is started for the process. The statement commits all changes made by SQL schema statements and SQL data change statements during the unit of work.

Invocation for COMMIT

This statement can be embedded in an application program or issued interactively. It is an executable statement that can be dynamically prepared. It cannot be used in the IMS or CICS environment.

Authorization for COMMIT

None required.

Syntax for COMMIT



Description for COMMIT

The COMMIT statement ends the unit of recovery in which it is executed and a new unit of recovery is started for the process. The statement commits all changes made by SQL schema statements and SQL data change statements during the unit of work. For more information see [Chapter 7, “Statements,” on page 1079](#).

Notes for COMMIT

Recommended coding practices: Code an explicit COMMIT or ROLLBACK statement at the end of an application process. Either an implicit commit or rollback operation will be performed at the end of an application process depending on the application environment. Thus, a portable application should

explicitly execute a COMMIT or ROLLBACK statement before execution ends in those environments where explicit COMMIT or ROLLBACK is permitted.

Effect of COMMIT: All savepoints that are set within the unit of recovery are released, and all changes are committed for the following statements that are executed during the unit of recovery:

- ALTER
- COMMENT
- CREATE
- DELETE
- DROP
- EXPLAIN
- GRANT
- INSERT
- LABEL
- MERGE
- RENAME
- REVOKE
- UPDATE
- SELECT INTO with an SQL data change statement
- subselect with an SQL data change statement

SQL connections are ended when any of the following conditions apply:

- The connection is in the release pending status
- The connection is not in the release pending status but it is a remote connection and:
 - The DISCONNECT(AUTOMATIC) bind option is in effect, or
 - The DISCONNECT(CONDITIONAL) bind option is in effect and an open WITH HOLD cursor is not associated with the connection.

For existing connections, all LOB locators are disassociated, except for those locators for which a HOLD LOCATOR statement has been issued without a corresponding FREE LOCATOR statement. All open cursors that were declared without the WITH HOLD option are closed. All open cursors that were declared with the WITH HOLD option are preserved, along with any SELECT statements that were prepared for those cursors.

Static and dynamic INSERT, UPDATE, DELETE, and MERGE statements that reference declared global temporary tables that were defined without ON COMMIT DROP TABLE and are bound with or use the RELEASE(DEALLOCATE) option are kept past commit points. The statement is not kept across the commit point if one of the following conditions is true:

- The declared global temporary table is defined with the ON COMMIT DROP TABLE option.
- The statement uses the RELEASE(COMMIT) bind option.
- The statement also references a Db2 base object (for example, a table or view), and one of the following statements is true:
 - The base object reference is for a Db2 catalog table.
 - At the commit point, Db2 determines that another Db2 thread is waiting for an X-lock on the base object's database descriptor (DBD).
 - The statement references an XML function or operation, and at the commit point Db2 determines that the base object DBD S-lock for the XML operation must be released.
 - At the commit point, Db2 determines that a base object DBD S-lock that is used by the statement must be released and cannot be maintained across the commit point.

- Db2 determines that another Db2 thread is waiting for an X-lock on the Db2 package that contains the statement.

Prepared dynamic statements are kept past commit points if one of the following conditions is true:

- Dynamic caching is enabled for your system. In that case, all prepared SELECT and data change statements that are bound with KEEP DYNAMIC(YES) are kept past the commit point.
- The statements reference a declared global temporary table that was defined without ON COMMIT DROP TABLE, and the package was bound with or uses the RELEASE(DEALLOCATE) option. In that case, all prepared INSERT, UPDATE, DELETE, and MERGE statements that reference the declared global temporary table are kept across the commit point.

Prepared statements cannot be kept past a commit if any of the following conditions is true:

- SQL RELEASE has been issued for that site.
- Bind option DISCONNECT(AUTOMATIC) was used.
- Bind option DISCONNECT(CONDITIONAL) was used and there are no open WITH HOLD cursors for that site.
- The statement references a declared global temporary table, has no open WITH HOLD cursor, and is in a package that is bound with the RELEASE(COMMIT) option.
- The statement references a declared global temporary table that was defined with the ON COMMIT DROP TABLE option. The statement also has no open WITH HOLD cursor, and the statement's package is bound with or uses the RELEASE(DEALLOCATE) option.

All implicitly acquired locks are released, except for the following locks:

- Locks that are required for the cursors that were not closed
- Table and table space locks when the RELEASE parameter on the bind command was not RELEASE(COMMIT)
- LOB locks and LOB table space locks that are required for held LOB locators

For an explanation of the duration of explicitly acquired locks, see [The duration of a lock \(Db2 Performance\)](#).

All rows of every created temporary table of the application process are deleted with the exception that the rows of a created temporary table are not deleted if any program in the application process has an open WITH HOLD cursor that is dependent on that table. In addition, if RELEASE(COMMIT) is in effect, the logical work files for the created temporary tables whose rows are deleted are also deleted.

All rows of every declared temporary table of the application process are deleted with these exceptions:

- The rows of a declared temporary table that is defined with the ON COMMIT PRESERVE ROWS attribute are not deleted.
- The rows of a declared temporary table that is defined with the ON COMMIT DELETE ROWS attribute are not deleted if any program in the application process has an open WITH HOLD cursor that is dependent on that table.

Implicit commit operations: In all Db2 environments, the normal termination of a process is an implicit commit operation.

Restrictions on the use of COMMIT: The COMMIT statement cannot be used in the IMS or CICS environment. To cause a commit operation in these environments, SQL programs must use the call prescribed by their transaction manager. The effect of these commit operations on Db2 data is the same as that of the SQL COMMIT statement.

The COMMIT statement cannot be used in a stored procedure if the procedure is in the calling chain of a user-defined function or a trigger or Db2 is not the commit coordinator.

Effect of commit on special registers: Issuing a COMMIT statement may cause special registers to be re-initialized. Whether one of these special registers is affected by a commit depends on whether the special register has been explicitly set within the application process. For example, assume that the PATH special register has not been explicitly set with a SET PATH statement in the application process. After a

commit, the value of PATH is re-initialized. For information on the initialization of PATH, which can take the current value of CURRENT SQLID into consideration, see [“CURRENT PATH special register”](#) on page 200.

Effect of commit on global variables: Global variables are not controlled at the transaction level. Issuing a COMMIT statement does not effect the contents of a global variable.

Example for COMMIT

Commit all Db2 database changes made since the unit of recovery was started.

```
COMMIT WORK;
```

CONNECT statement

The CONNECT statement connects an application process to a database server. This server becomes the *current server* for the process. The CONNECT statement of Db2 for z/OS is equivalent to *CONNECT (Type 2)* in [PDF SQL Reference for Cross-Platform Development - Version 6](#).

For more information about connections, the current server, commit processing, and distributed and remote units of work, see [Distributed relational databases \(Introduction to Db2 for z/OS\)](#).

Invocation for CONNECT

This statement can only be embedded within an application program. It is an executable statement that cannot be dynamically prepared. It must not be specified in Java.

Authorization for CONNECT

The primary authorization ID of the process or the authorization ID that is specified in this statement must be authorized to connect to the specified server. The server checks the authorization when the statement is executed, and determines the specific authorization that is required. For more information, see [Authorization IDs \(Managing Security\)](#).

Syntax for CONNECT

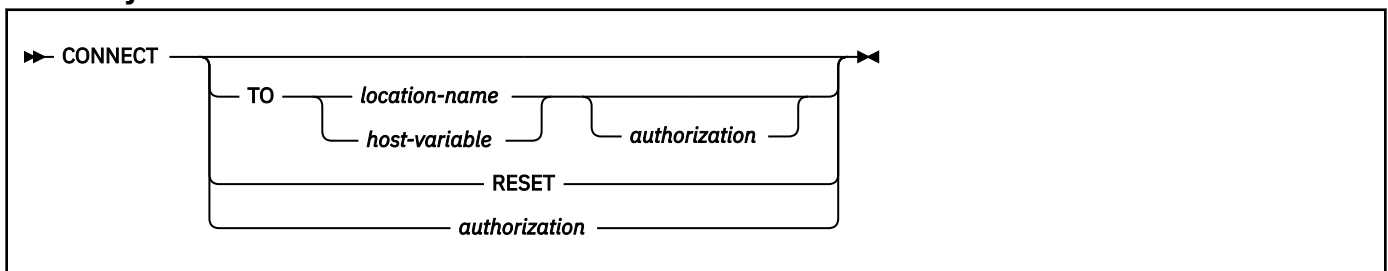

authorization:

```
USER host-variable USING host-variable
```

Description for CONNECT

TO *location-name* or *host-variable*

Identifies the server by the specified location name or by the location name that is contained in the host variable. If a host variable is specified:

- It must be a CHAR or VARCHAR variable with a length attribute that is not greater than 16. (A C NUL-terminated character string can be up to 17 bytes long.)
- It must not be followed by an indicator variable.
- The location name must be left-aligned within the host variable and must conform to the rules for forming an ordinary identifier.
- If the length of the location name is less than the length of the host variable, it must be padded on the right with blanks.
- It must not contain lowercase characters.
- If used with an SQL procedure language application, host variable must be a qualified SQL-variable name or a qualified SQL-parameter name.

When the CONNECT statement is executed:

- The location name must identify a server that is known to the local Db2 subsystem. Hence, the location name must be the location name of the local Db2 subsystem or it must appear in the LOCATION column of the SYSIBM.LOCATIONS table.
- The application process must not have an existing connection to the specified server, if the SQLRULES(STD) bind option is in effect.
- The application process must be in a connectable state, if the transaction is participating in a remote unit of work.

RESET

CONNECT RESET is equivalent to CONNECT TO *x* where *x* is the location name of the local Db2 subsystem.

- If the SQLRULES(DB2) bind option is in effect, CONNECT RESET establishes the local Db2 subsystem as the current SQL connection.
- If the SQLRULES(STD) bind option is in effect, CONNECT RESET establishes the local Db2 subsystem as the current SQL connection only if the connection does not exist.

authorization

Specifies an authorization ID and a password that is used to verify that the authorization ID is authorized to connect to the server. Authorization cannot be specified when the connection type is IMS or CICS for a connection to the local Db2 subsystem. An attempt to do so causes an SQL error.

USER *host-variable*

Identifies the authorization name to use for connecting to the server. The value of *host-variable* must satisfy the following rules:

- The value must be a CHAR or VARCHAR variable with a length attribute that is not greater than 128.
- The value must be left-aligned within the host variable and must conform to the rules for forming an authorization name.
- The value must not be followed by an indicator variable.
- The value must be padded on the right with blanks if the length of the authorization name is less than the length of the host variable.

For a connection to the local Db2 subsystem, a user ID that is longer than 8 characters causes an SQL error.

USING *host-variable*

Identifies the password of the authorization name to use for connecting to the server. The value of *host-variable* must satisfy the following rules:

- The value must be a CHAR or VARCHAR variable with a length attribute that is not greater than 128.
- The value must be left-aligned.
- The value must not include an indicator variable.

- The value must be padded on the right with blanks if the length of the password is less than the length of the host variable.
- The value must not contain lowercase characters.

For a connection to the local Db2 subsystem, a user ID that is longer than 100 characters causes an SQL error.

For more information, see [PASSWORD or PHRASE \(Specify user password or password phrase\) \(Security Server RACF Command Language Reference\)](#).

CONNECT USER/USING is equivalent to CONNECT TO *x* USER/USING where *x* is the location name of the local Db2 subsystem (which has the semantic of CONNECT RESET).

CONNECT with no operand

This form of the CONNECT statement returns information about the current server in the SQLERRP field of the SQLCA. SQLERRP returns blanks if the application process is in the unconnected state.

Executing a CONNECT with no operand has no effect on connection states.

In a remote unit of work, this form of CONNECT does not require the application process to be in a connectable state.

Notes for CONNECT

Successful connections

Except for a CONNECT with no operand statement, if execution of the CONNECT statement is successful the actions depend on the unit of work type:

Distributed units of work

One of the following scenarios takes place in a *distributed unit of work*:

- If the location name does not identify a server that the application process is already connected to, an SQL connection to the server is created and placed in the current and held state. The previously current SQL connection, if any, is placed in the dormant state.
- If the location name identifies a server that application process is already connected to, the associated SQL connection is dormant, and the SQLRULES(DB2) option is in effect, the SQL connection is placed in the current state. The previously current SQL connection, if any, is placed in the dormant state.
- If the location name identifies a server that the application process is already connected to, the associated SQL connection is current, and the SQLRULES(DB2) option is in effect, the states of all SQL connections of the application process are unchanged.

Remote units of work

The following actions occur in a *remote unit of work*:

- The application process is connected to the specified server.
- An existing SQL connection of the application process is ended. As a result, all cursors of that SQL connection are closed, all prepared statements of that connection are destroyed, and so on.
- The location name is placed in the CURRENT SERVER special register.
- When CONNECT is used to connect back to the local Db2 subsystem, the CURRENT SQLID special register is reinitialized if the USER/USING clause is specified.
- Information about the server is placed in the SQLERRP field of the SQLCA. If the server is a Db2 product, the information has the form *pppvrrm*.

The product identifier (PRDID) value is an 8-byte character value in *pppvrrm* format, where: *ppp* is a 3-letter product code; *vv* is the version; *rr* is the release; and *m* is the modification level. In Db2 12 for z/OS, the modification level indicates a range of function levels:

DSN12015 for V12R1M500 or higher.

DSN12010 for V12R1M100.

For more information, see [Product identifier \(PRDID\) values in Db2 for z/OS \(Db2 Administration Guide\)](#).

- Additional information about the connection is placed in the SQLERRMC field of the SQLCA. The contents are product-specific.

Tip: Use the GET DIAGNOSTICS statement to get detailed diagnostic information about the last SQL statement that was executed.

Unsuccessful connections

Except for a CONNECT with no operand statement, if execution of the CONNECT statement is unsuccessful:

Distributed units of work

In a distributed unit of work, the connection state of the application process and the states of its SQL connections are unchanged unless the failure was because an authorization check failed. If this is the case, the connection is placed in the connectable and unconnected state.

Remote units of work

In a remote unit of work, the SQLERRP field of the SQLCA is set to the name of the Db2 requester module that detected the error.

If execution of the CONNECT statement is unsuccessful because the application process is not in the connectable state, the connection state of the application process is unchanged. If execution of the CONNECT statement is unsuccessful for any other reason, CURRENT SERVER is set to blanks and the application process is placed in the connectable and unconnected state.

Authorization

If the server is a Db2 subsystem, a user is authenticated in the following way:

- Db2 invokes RACF via the RACROUTE macro with REQUEST=VERIFY to verify the password.
- If the password is verified, Db2 then invokes RACF again via the RACROUTE macro with REQUEST=AUTH, to check whether the authorization ID is allowed to use Db2 resources that are defined to RACF.
- Db2 then invokes the connection exit routine if one is defined.
- The connection then has a primary authorization ID, possibly one or more secondary IDs, and an SQL ID.

If the server is a remote Db2 subsystem, the requester generates authentication tokens and sends them to the remote site in the following way:

- The SECURITY_OUT column in SYSIBM.LUNAMES for SNA or the SECURITY_OUT column in SYSIBM.IPNAMES for TCP/IP must have one of the following values:
 - 'A' (already verified)
 - 'D' (user ID and security-sensitive data encryption; TCP/IP only)
 - 'E' (user ID, password, and security-sensitive data encryption; TCP/IP only)
 - 'P' (password)

When the value is 'A', the user ID and password that is specified on the CONNECT is still sent.

When the value is 'D', 'E', or 'P', the requester encrypts the user ID and password that is specified on the CONNECT for TCP/IP. However, if the Integrated Cryptographic Service Facility (ICSF) is not configured at the requester or if the server does not support encryption, one of the following actions occurs:

- If the value of SECURITY_OUT in SYSIBM.IPNAMES is 'D' or 'E', SQLCODE -904 is returned if ICSF is not configured at the requester, and SQLCODE -30082 is returned if the server does not support encryption.
- If the value of SECURITY_OUT in SYSIBM.IPNAMES is 'P', the requester does not encrypt the user ID and password and flows the tokens in clear text.

- For SNA, the ENCRYPTPSWDS column in SYSIBM.SYSLUNAMES must be not contain 'Y'.
- The authorization ID and password are verified at the server.
- In all cases, outbound translation—as specified in SYSIBM.USERNAMES—is not done.

Distributed unit of work

In general, the following are true:

- A CONNECT statement with the TO clause and the USER/USING clause can be executed only if no current or dormant connection to the named server exists. However, if the named server is the local Db2 subsystem and the CONNECT statement is the first SQL statement that is executed after the Db2 thread is created, the CONNECT statement executes successfully.
- A CONNECT statement without the TO clause but with the USER/USING clause can be executed only if no current or dormant connection to the local Db2 subsystem exists. However, if the CONNECT statement is the first SQL statement that is executed after the Db2 thread is created, the CONNECT statement executes successfully.

Remote unit of work

If the authorization check fails, the connection is placed in the connectable and unconnected state.

Precompiler options

Regardless of whether a program is precompiled with the CONNECT(1) or CONNECT(2) option, Db2 for z/OS negotiates with the remote server during the connection process to determine how to perform commits. If the remote server does not support the two-phase commit protocol, Db2 downgrades to perform one-phase commits.

Programs containing CONNECT statements that are precompiled with different CONNECT precompiler options cannot execute as part of the same application process. An error occurs when an attempt is made to execute the invalid CONNECT statement.

Host variables

If a CONNECT statement contains host variables, the contents of the host variables are assumed to be in the encoding scheme that was specified in the ENCODING parameter when the package or plan that contains the statement was bound.

Error processing

A CONNECT statement can return and indicate a successful execution even when no physical connection yet exists. Db2 delays the physical connection process, when possible, to economize on the number of messages it sends to a server. Therefore, errors in CONNECT statement processing can be reported following the next executable SQL statement, not immediately following the CONNECT statement.

Restrictions on array types and array variables

In any SQL statement other than a CALL statement, array types and array variables must not be referenced after a connection at a remote server is established. This restriction includes an SQL statement that executes at a remote server as a result of a three-part name or alias that resolves to an object at a remote server. An exception is that an array element can be the target of a FETCH, SELECT INTO, SET *assignment-statement*, or VALUES INTO statement in an SQL routine even when the statement is executed at a remote server.

Examples for CONNECT

Example 1: Connect an application to a DBMS

The location name is in the character-string variable *LOCNAME*, the authorization identifier is in the character-string variable *AUTHID*, and the password is in the character-string variable *PASSWORD*.

```
EXEC SQL CONNECT TO :LOCNAME USER :AUTHID USING :PASSWORD;
```

Example 2: Obtain information about the current server

```
EXEC SQL CONNECT;
```

Example 3: Execute SQL statements in a distributed unit of work

The first CONNECT statement creates a connection to the EASTDB server. The second CONNECT statement creates a connection to the WESTDB server, and places the SQL connection to EASTDB in the dormant state.

```
EXEC SQL CONNECT TO EASTDB;  
-- execute statements referencing objects at EASTDB  
EXEC SQL CONNECT TO WESTDB;  
-- execute statements referencing objects at WESTDB
```

Example 4: Connect the application to a DBMS whose location identifier is in the character-string variable LOC using the authorization identifier in the character-string variable AUTHID and the password in the character-string variable PASSWORD. Perform work for the user, and then release the connection and connect again using a different user ID and password.

```
EXEC SQL CONNECT TO :LOC USER :AUTHID USING :PASSWORD;  
-- execute SQL statements accessing data on the server  
RELEASE :LOC;  
EXEC SQL COMMIT;  
-- set AUTHID and PASSWORD to new values  
EXEC SQL CONNECT TO :LOC USER :AUTHID USING :PASSWORD;  
-- execute SQL statements accessing data on the server
```

Example 5: Change servers in a remote unit of work.

Assume that the application connected to a remote Db2 server, opened a cursor, and fetched rows from the cursor's result table. Later, to connect to the local Db2 subsystem, the application executes the following statements:

```
EXEC SQL COMMIT WORK;  
EXEC SQL CONNECT RESET;
```

The COMMIT is required because opening the cursor caused the application to enter the unconnectable and connected state. The unconnectable state means that the connection has started a transaction and cannot connect to another server until the transaction completes. Issuing a COMMIT statement ends the transaction. Issuing a CONNECT statement with the RESET option reconnects the application to the local server and returns the application to the unconnectable and connected state.

If the cursor was declared with the WITH HOLD clause and was not closed with a CLOSE statement, it would still be open even after execution of the COMMIT statement. However, it would be closed with the execution of the CONNECT statement.

Related concepts

[Explicit CONNECT statements \(Introduction to Db2 for z/OS\)](#)

[Distributed relational databases \(Introduction to Db2 for z/OS\)](#)

Related tasks

[Accessing distributed data by using explicit CONNECT statements \(Db2 Application programming and SQL\)](#)

[Reusing a local trusted connection through the SQL CONNECT statement \(Managing Security\)](#)

CREATE ALIAS statement

The CREATE ALIAS statement defines an alias for a table, a view, or a sequence. The definition is recorded in the Db2 catalog at the current server.

Invocation for CREATE ALIAS

This statement can be embedded in an application program or issued interactively. It is an executable statement that can be dynamically prepared only if DYNAMICRULES RUN behavior is in effect. For more information, see [“Authorization IDs and dynamic SQL” on page 94](#).

Authorization for CREATE ALIAS

To create an alias, the privilege set must include at least one of the listed authorities or privileges:

To create an alias for a table or a view:

- For a table or a view:
 - The CREATEALIAS privilege
 - SYSADM or SYSCTRL authority
 - System DBADM authority
 - Installation SYSOPR authority (when the current SQLID of the process is set to SYSINSTL)
- For a table only:
 - DBADM or DBCTRL authority on the database that contains the table, if the value of field DBADM CREATE AUTH on installation panel DSNTIPP is YES

To create an alias for a sequence:

- The CREATEIN privilege on the schema
- SYSADM or SYSCTRL authority
- System DBADM authority
- Installation SYSOPR authority (when the current SQLID of the process is set to SYSINSTL)

If the database is implicitly created, the database privileges must be on the implicit database or on DSNDB04.

Privilege set: If the statement is embedded in an application program, the privilege set is the privileges that are held by the owner of the plan or package. If the owner of the plan or package is a role, this role must hold the privileges for the privilege set. If the specified alias name includes a qualifier that is not the same as this authorization ID, the privilege set must include one of the following authorities:

- SYSADM or SYSCTRL authority
- System DBADM authority
- DBADM or DBCTRL authority on the database that contains the table, if the alias is for a table and the value of field DBADM CREATE AUTH on installation panel DSNTIPP is YES

If ROLE AS OBJECT OWNER is in effect, the schema qualifier must be the same as the role, unless the role has the CREATEIN privilege on the schema, SYSADM authority, SYSCTRL authority, or system DBADM authority.

If ROLE AS OBJECT OWNER is not in effect, one of the following rules applies:

- If the privilege set lacks the CREATEIN privilege on the schema, SYSADM authority, SYSCTRL authority, or system DBADM authority, the schema qualifier (implicit or explicit) must be the same as one of the authorization ids of the process.
- If the privilege set includes SYSADM authority, SYSCTRL authority, or system DBADM authority, the schema qualifier can be any valid schema name.

If the statement is dynamically prepared, the privilege set is the privileges that are held by the SQL authorization ID of the process unless the process is within a trusted context and the ROLE AS OBJECT OWNER clause is specified. If the process is not running in a trusted context that is defined with the ROLE AS OBJECT OWNER clause and the specified alias name includes a qualifier that is not the same as this authorization ID:

- The privilege set must include SYSADM, SYSCTRL, or system DBADM authority.
- The privilege set must include DBADM or DBCTRL authority on the database that contains the table, if the alias is for a table and the value of field DBADM CREATE AUTH on installation panel DSNTIPP is YES.
- The qualifier must be the same as one of the authorization IDs of the process and the privileges that are held by that authorization ID must include the CREATEALIAS privilege. This is an exception to the rule that the privilege set is the privileges that are held by the SQL authorization ID of the process.

Syntax for CREATE ALIAS

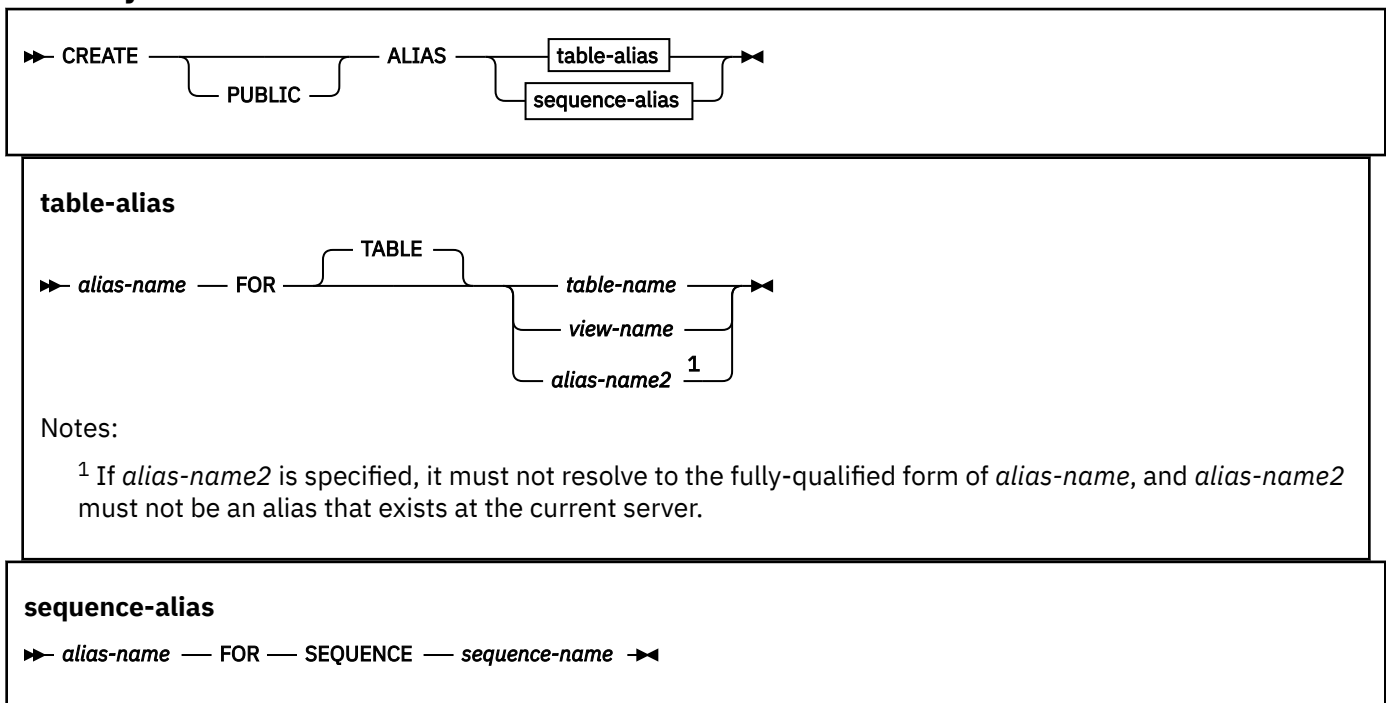

Description for CREATE ALIAS

PUBLIC

Specifies that the alias is an object in the system schema SYSPUBLIC.

The PUBLIC keyword is used to create a public alias. If the keyword PUBLIC is not specified, the alias that is created is a private alias.

PUBLIC can be specified only for a sequence.

alias-name

Names the alias.

For a table alias, the name, including the implicit or explicit qualifier, must not identify a table, view, or table alias that exists at the current server, or a table that exists in the SYSIBM.SYSPENDINGOBJECTS catalog table.

For a sequence alias, the name, including the implicit or explicit qualifier, must not identify a sequence or sequence alias that exists at the current server.

If a two-part name is specified, the schema name cannot begin with 'SYS', except if PUBLIC is specified, in which case the schema name must be SYSPUBLIC. The unqualified name must not be the same as an existing synonym.

If the name is qualified, the name can be a two-part or three-part name. If a three-part name is used, the first part must match the value of the field Db2 LOCATION NAME on installation panel DSNTIPR at the current server. (If the current server is not the local Db2, this name is not necessarily the name in the CURRENT SERVER special register.)

When an application uses three-part name aliases for remote objects and DRDA access, the application program must be bound at each location that is specified in the three-part names.

FOR TABLE *table-name*, *view-name*, or *alias-name2*

Identifies the table, view, or alias for which *alias-name* is defined. The table, view or alias need not exist at the time the alias is defined. If it does not exist when the alias is created, a warning is returned. However, the referenced object must exist when a SQL statement that contains the alias is used, otherwise an error is returned. If the table or view does exist, the referenced object can be at the current server or at another server.

If *alias-name2* is specified it must be a three-part name. The first part of the three-part name must be the location name for a remote server. If the alias exists, the alias must exist at the remote server identified by the location name.

If a table is identified, it must not be an auxiliary table, a declared temporary table, or a table that is implicitly created for an XML column.

If *alias-name2* is specified, it must not resolve to the fully-qualified form of *alias-name*, and *alias-name2* must not be an alias that exists at the current server.

FOR SEQUENCE *sequence-name*

Identifies the sequence for which *alias-name* is defined. The *sequence-name* must not be a sequence that is generated by the Db2 subsystem for an identity column or a DOCID column. The schema name must not begin with 'SYS' unless the schema name is 'SYSADM'. *sequence-name* must not be an existing alias for a sequence.

The sequence need not exist at the time the alias is defined. If *sequence-name* does not exist when the alias is created, a warning is returned. However, the referenced object must exist when a SQL statement that contains the alias is used, otherwise an error is returned.

Notes for CREATE ALIAS

Owner privileges:

There are no specific privileges on an alias. For more information about ownership of an object, see [“Authorization, privileges, permissions, masks, and object ownership”](#) on page 90.

PUBLIC aliases:

If the PUBLIC keyword is specified or if SYSPUBLIC is explicitly specified as the schema qualifier for *alias-name*, a public alias is created.

Resolving an unqualified name:

When an unqualified name is resolved, private aliases are considered before public aliases.

Examples for CREATE ALIAS

Example 1

Create an alias for a catalog table at a Db2 with location name DB2USCALABOA5281.

```
CREATE ALIAS LATABLES FOR DB2USCALABOA5281.SYSIBM.SYSTABLES;
```

Example 2

Create a public alias called SEQs for a sequence named JOE.JOESSEQ.

```
CREATE PUBLIC ALIAS SEQs FOR SEQUENCE JOE.JOESSEQ;
```

The alias can be referenced as SYSPUBLIC.SEQs, or simply as SEQs if a private sequence or alias named SEQs does not exist.

Related concepts

Aliases

An *alias* is an alternative name for an object such as a table, view, sequence, or another alias. It can be used to reference an object wherever that object can be referenced directly.

Naming conventions

The rules for forming a name depend on the type of the object designated by the name.

Aliases (Introduction to Db2 for z/OS)

CREATE AUXILIARY TABLE statement

The CREATE AUXILIARY TABLE statement creates an auxiliary table at the current server for storing LOB data.

Invocation for CREATE AUXILIARY TABLE

This statement can be embedded in an application program or issued interactively if the value of special register CURRENT RULES is 'DB2' and the table space is explicitly created when the statement is executed. It is an executable statement that can be dynamically prepared only if DYNAMICRULES run behavior is implicitly or explicitly specified.

Do not use this statement if Db2 implicitly creates the auxiliary table. For more information, see [LOB table space implicit creation \(Db2 Administration Guide\)](#).

Authorization for CREATE AUXILIARY TABLE

The privilege set that is defined below must include at least one of the following:

- The CREATETAB privilege for the database implicitly or explicitly specified by the IN clause
- DBADM, DBCTRL, or DBMAINT authority for the database
- SYSADM or SYSCTRL authority
- System DBADM
- Installation SYSOPR authority (when the current SQLID of the process is set to SYSINSTL)

Privilege set: If the statement is embedded in an application program, the privilege set is the privileges that are held by the owner of the plan or package. If the application is bound in a trusted context with the ROLE AS OBJECT OWNER clause specifies, a role is the owner. Otherwise, an authorization ID is the owner. If the specified table name includes a qualifier that is not the same as this authorization ID, the privilege set must include SYSADM or SYSCTRL authority, DBADM authority for the database, or DBCTRL authority for the database.

If ROLE AS OBJECT OWNER is in effect, the schema qualifier must be the same as the role, unless the role has the CREATEIN privilege on the schema, SYSADM authority, or SYSCTRL authority.

If ROLE AS OBJECT OWNER is not in effect, one of the following rules applies:

- If the privilege set lacks the CREATIN privilege on the schema, SYSADM authority, or SYSCTRL authority, the schema qualifier (implicit or explicit) must be the same as one of the authorization ids of the process.
- If the privilege set includes SYSADM authority or SYSCTRL authority, the schema qualifier can be any valid schema name.

If the statement is dynamically prepared, the privilege set is the privileges that are held by the SQL authorization ID of the process unless the process is within a trusted context and the ROLE AS OBJECT OWNER clause is specified. In that case, the privilege set is the set of privileges that are held by the role that is associated with the primary authorization ID of the process. If the process is in a trusted context, any authorization ID can be the qualifier. However, if the process is not in a trusted context and if the specified table name includes a qualifier that is not the same as the SQL authorization ID of the process, the following rules apply:

- If the privilege set includes SYSADM or SYSCTRL authority (or DBADM authority for the database, or DBCTRL authority for the database when creating a table), the schema qualifier can be any valid schema name.
- If the privilege set lacks SYSADM or SYSCTRL authority (or DBADM authority for the database, or DBCTRL authority for the database when creating a table), the schema qualifier is valid only if it is the same as one of the authorization IDs of the process and the privilege set that are held by that authorization ID includes all²⁶ privileges needed to create the table.

Syntax for CREATE AUXILIARY TABLE

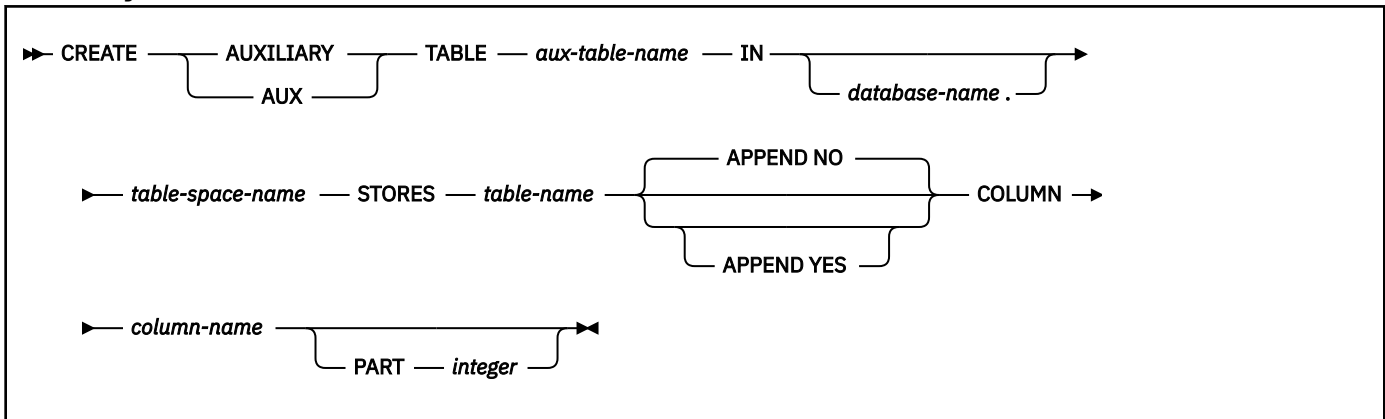

Description for CREATE AUXILIARY TABLE

AUXILIARY or AUX

Specifies a table that is used to store the LOB data for a LOB column (or a column with a distinct type that is based on a LOB data type).

aux-table-name

Names the auxiliary table. The name, including the implicit or explicit qualifiers, must not identify a table, view, alias, or synonym that exists at the current server, or a table that exists in the SYSIBM.SYSPENDINGOBJECTS catalog table.

IN database-name.table-space-name or IN table-space-name

Identifies the table space in which the auxiliary table is created. The name must identify an empty LOB table space that currently exists at the current server. The LOB table space must be in the same database as the associated base table.

If you specify a database and a table space, the table space must belong to the specified database. If you specify only a table space, it must belong to the database that contains the specified table space. If you specify only a table space, this table space must belong to DSNDB04. This type of table space is only created when `SET CURRENT RULES='DB2'` is specified.

STORES table-name COLUMN column-name

Identifies the base table and the column of that table that is to be stored in the auxiliary table. If the base table is nonpartitioned, an auxiliary table must not already exist for the specified column. If the base table is partitioned, an auxiliary table must not already exist for the specified column and specified partition.

The encoding scheme for the LOB data stored in the auxiliary table is the same as the encoding scheme for the base table. It is either ASCII, EBCDIC, or UNICODE depending on the value of the CCSID clause when the base table was created.

APPEND NO or APPEND YES

Specifies whether append processing is used for the table. The APPEND clause must not be specified for a table in a work file table space.

²⁶ Exception: The CREATETAB privilege is checked on the SQL authorization ID of the process.

If the base table is in a partition-by-range table space, the APPEND option on the LOB table might be different for each partition (depending if the LOB table space and associated objects for each partition are created explicitly or implicitly). If the base table is in a partition-by-growth table space, the APPEND attributes of LOB table will be inherited by each partition.

APPEND NO

Specifies that append processing is not used for the table. For insert and LOAD operations, Db2 will attempt to place data rows in a well clustered manner with respect to the value in the row's cluster key columns.

APPEND NO is the default

APPEND YES

Specifies that data rows are placed into the table without regard to clustering during the insert and LOAD operations.

PART *integer*

Specifies the partition of the base table for which the auxiliary table is to store the specified column. You can specify PART only if the base table is defined in a partitioned table space, and no other auxiliary table exists for the same LOB column of the base table.

Notes for CREATE AUXILIARY TABLE

Owner privileges

There are no specific privileges on an auxiliary table. For more information about ownership of an object, see [“Authorization, privileges, permissions, masks, and object ownership” on page 90.](#)

Determining the number of auxiliary tables to create

For partitioned tables, each partition of the base table requires a separate LOB table space, auxiliary table, and auxiliary index for each LOB column.

Auxiliary tables in LOB table spaces that are logged

When you create an auxiliary table in a LOB table space that is LOGGED, and the associated base table space is NOT LOGGED, the logging attribute of the LOB table space is implicitly changed to NOT LOGGED and the logging attributes of the base table space and the LOB table space are linked.

Append processing and unused free space in a table

An update or delete of LOB data creates some free space in the LOB table that can be used by the next insert. If the table uses append processing, any free space that is not at the end of the table space will not be reused during the insert operation. Any unused free space in the table can be reclaimed by running the REORG utility with either the SHRELEV REFERENCE or SHRLEVEL CHANGE keywords. The REORG utility is not influenced by the APPEND option.

Example for CREATE AUXILIARY TABLE

Assume that a column named EMP_PHOTO with a data type of BLOB(110K) has been added to sample employee table DSN8C10.EMP for each employee's photo. Create auxiliary table EMP_PHOTO_ATAB to store the BLOB data for the BLOB column in LOB table space DSN8D12A.PHOTOLTS.

```
CREATE AUX TABLE EMP_PHOTO_ATAB
  IN DSN8D12A.PHOTOLTS
  STORES DSN8C10.EMP
  COLUMN EMP_PHOTO;
```

Related concepts

[LOB table spaces \(Db2 Administration Guide\)](#)

[Naming conventions](#)

The rules for forming a name depend on the type of the object designated by the name.

Related tasks

[Creating large objects \(Introduction to Db2 for z/OS\)](#)

Storing LOB data in Db2 tables ([Db2 Application programming and SQL](#))

Related reference

CREATE LOB TABLESPACE

The CREATE LOB TABLESPACE statement defines a large object (LOB) table space at the current server. If your data for a table does not fit entirely within a data page, you can define one or more columns as LOB columns. Each LOB column must have an associated auxiliary table in a LOB table space. If the table space for the base table is partitioned, an associated auxiliary table in a LOB table space is required for each LOB column, for each partition of the table space for the base table.

CREATE TABLE statement

The CREATE TABLE statement defines a table. The definition must include its name and the names and attributes of its columns. The definition can include other attributes of the table, such as its primary key and its table space.

CREATE DATABASE statement

The CREATE DATABASE statement defines a Db2 database at the current server.

Invocation for CREATE DATABASE

This statement can be embedded in an application program or issued interactively. It is an executable statement that can be dynamically prepared only if DYNAMICRULES RUN behavior is in effect. For more information, see [“Authorization IDs and dynamic SQL” on page 94](#).

Authorization for CREATE DATABASE

The privilege set that is defined below must include at least one of the following:

- The CREATEDBA privilege
- The CREATEDBC privilege
- SYSADM or SYSCTRL authority
- System DBADM
- Installation SYSOPR authority (when the current SQLID of the process is set to SYSINSTL)

If the database is created as a workfile database, the privilege set that is defined below must include SYSADM authority.

Privilege set: If the statement is embedded in an application program, the privilege set is the privileges that are held by the owner of the plan or package.

If the statement is dynamically prepared, the privilege set is the privileges that are held by the SQL authorization ID of the process unless the process is within a trusted context and the ROLE AS OBJECT OWNER clause is specified. In that case, the privilege set is the set of privileges that are held by the role that is associated with the primary authorization ID of the process.

See [“Notes for CREATE DATABASE” on page 1423](#) for the authorization effect of a successful CREATE DATABASE statement.

Syntax for CREATE DATABASE

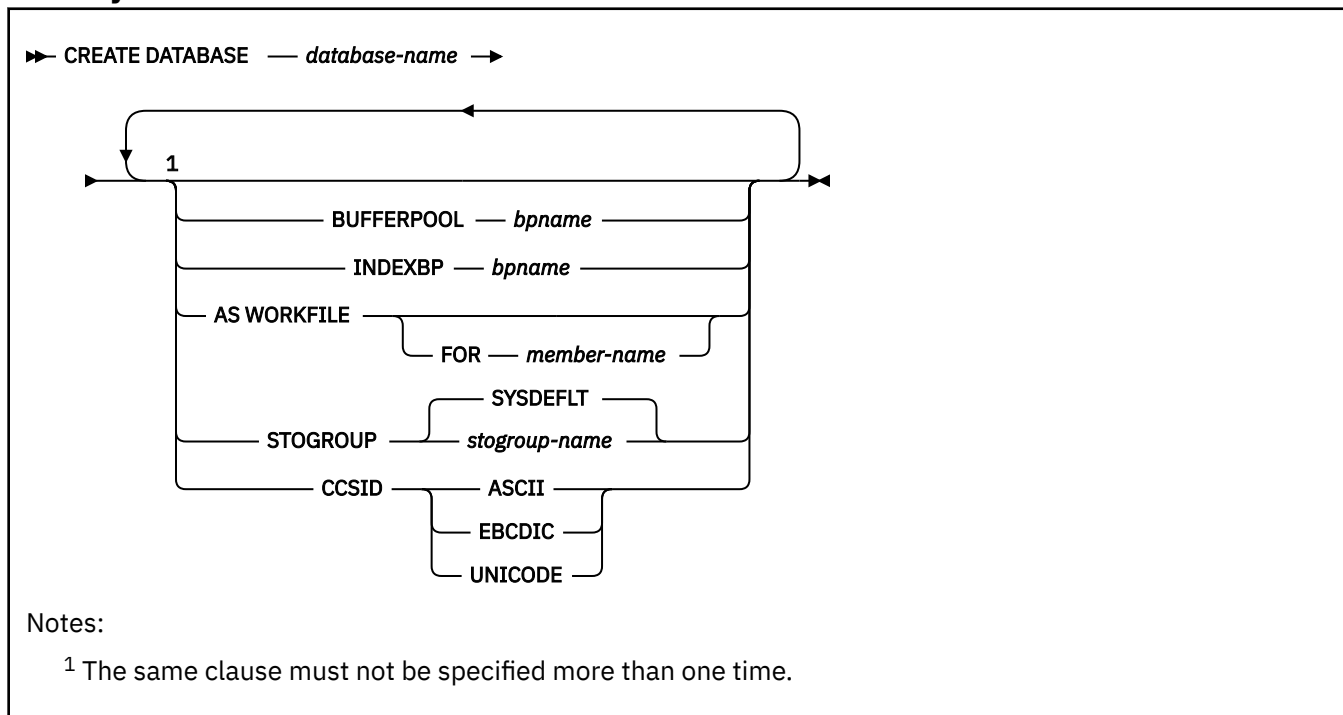

Description for CREATE DATABASE

database-name

Names the database. The name must not start with DSNDB and must not identify a database that exists at the current server. *database-name* must not be in the form of eight characters that start with DSN followed by exactly five digits. If the database is to be a work file database in a data sharing environment, DSNDB07 is an acceptable work file database name. However, only one member of a data sharing group can use DSNDB07 as the name of its work file database.

BUFFERPOOL *bpname*

Specifies the default buffer pool name to be used for table spaces created within the database. If the database is a work file database, 8KB and 16KB buffer pools cannot be specified. See [“Naming conventions in SQL” on page 79](#) for more details about *bpname*.

If you omit the BUFFERPOOL clause, the buffer pool for the TBSBPOOL subsystem parameter value is used. If the table space is implicitly created, Db2 selects the buffer pool as described in [Implicitly defined table spaces \(Db2 Administration Guide\)](#).

INDEXBP *bpname*

Specifies the default buffer pool name to be used for the indexes created within the database. The name can identify a 4KB, 8KB, 16KB, or 32KB buffer pool. See [“Naming conventions in SQL” on page 79](#) for more details about *bpname*.

If you omit the INDEXBP clause, the buffer pool specified for user indexes on installation panel DSNTIP1 is used. The default value for the user indexes field on that panel is BP0.

AS WORKFILE

Specifies the database is a work file database. AS WORKFILE can be specified only in a data sharing environment. Only one work file database can be created for each Db2 subsystem. The work file database is used for work files, created global temporary table, declared temporary tables, and sensitive static scrollable cursors.

PUBLIC implicitly receives the CREATETAB privilege (without GRANT authority) to define a declared temporary table in the work file database. This implicit privilege is not recorded in the Db2 catalog and cannot be revoked.

The CCSID clause is not supported for a work file database. If you specify AS WORKFILE, do not use the CCSID clause.

FOR *member-name*

Specifies the member for which this database is to be created. Specify FOR *member-name* only in a data sharing environment.

If FOR *member-name* is not specified, the member is the Db2 subsystem on which the CREATE DATABASE statement is executed.

STOGROUP *stogroup-name*

Specifies the storage group to be used, as required, as a default storage group to support DASD space requirements for table spaces and indexes within the database. The default is SYSDEFLT.

CCSID *encoding-scheme*

Specifies the default encoding scheme for data stored in the database. The default applies to table spaces created in the database. All tables stored within a table space must use the same encoding scheme.

ASCII

Specifies that the data must be encoded using the ASCII CCSIDs of the server.

EBCDIC

Specifies that the data must be encoded using the EBCDIC CCSIDs of the server.

UNICODE

Specifies that the data must be encoded using the UNICODE CCSIDs of the server.

Usually, each encoding scheme requires only a single CCSID. Additional CCSIDs are needed when mixed, graphic, or UNICODE data is used.

The option defaults to the value of field DEF ENCODING SCHEME on installation panel DSNTIPF.

Do not use the CCSID clause if you specify the AS WORKFILE clause.

Notes for CREATE DATABASE

If the statement is embedded in an application program, the owner of the plan or package is the owner of the database. If the statement is dynamically prepared, the SQL authorization ID of the process is the owner of the database.

If the owner of the database has the CREATEDBA, SYSADM, or SYSCTRL authority, the owner acquires DBADM authority for the database. DBADM authority for a database includes table privileges on all tables in that database. Thus, if a user with SYSCTRL authority creates a database, that user has table privileges on all tables in that database. This is an exception to the rule that SYSCTRL authority does not include table privileges.

If the owner of the database has the CREATEDBC privilege, but not the CREATEDBA privilege, the owner acquires DBCTRL authority for the database. In this case, no authorization ID has DBADM authority for the database until it is granted by an authorization ID with SYSADM authority.

Examples for CREATE DATABASE

Example 1

Create database DSN8D12P. Specify DSN8G120 as the default storage group to be used for the table spaces and indexes in the database. Specify 8KB buffer pool BP8K1 as the default buffer pool to be used for table spaces in the database, and BP2 as the default buffer pool to be used for indexes in the database.

```
CREATE DATABASE DSN8D12P
  STOGROUP DSN8G120
  BUFFERPOOL BP8K1
  INDEXBP BP2;
```

Example 2

Create database DSN8TEMP. Use the defaults for the default storage group and default buffer pool names. Specify ASCII as the default encoding scheme for data stored in the database.

```
CREATE DATABASE DSN8TEMP
  CCSID ASCII;
```

Related concepts

[Db2 databases \(Introduction to Db2 for z/OS\)](#)

[Naming conventions](#)

The rules for forming a name depend on the type of the object designated by the name.

Related tasks

[Creating Db2 databases \(Db2 Administration Guide\)](#)

CREATE FUNCTION statement (overview)

The CREATE FUNCTION statement registers a user-defined function with a database server. Each type of function that you can register with this statement is described separately.

External scalar

The function is written in a programming language and returns a scalar value. The external executable routine (package) is registered with a database server along with various attributes of the function. Each time that the function is invoked, the package executes one or more times. See [“CREATE FUNCTION statement \(external scalar function\)”](#) on page 1453.

External table

The function is written in a programming language. It returns a table to the subselect from which it was started by returning one row at a time, each time that the function is started. The external executable routine (package) is registered with a database server along with various attributes of the function. Each time that the function is invoked, the package executes one or more times. See [“CREATE FUNCTION statement \(external table function\)”](#) on page 1472.

Sourced

The function is implemented by invoking another function (either built-in, external, SQL, or sourced) that exists at the server. The function inherits the attributes of the underlying source function. A sourced function does not have an associated package. See [“CREATE FUNCTION statement \(sourced function\)”](#) on page 1498.

SQL scalar

The function is written exclusively in SQL statements and returns a scalar value. The body of an SQL scalar function is written in the SQL procedural language (SQL PL). The function is defined at the current server along with various attributes of the function.

Db2 supports two types of SQL scalar functions, inlined and compiled:

- *Inlined SQL scalar functions* contain a single RETURN statement, which returns the value of a simple expression. The function is not invoked as part of a query; instead, the *expression* in the RETURN statement of the function is copied (inlined) into the query itself. Therefore, a package is not generated for an inlined SQL scalar function.
- *Compiled SQL scalar functions* support a larger set of functionality, including all of the SQL PL statements. A package is generated for a compiled SQL scalar function. It contains the body of the function, including control statements. It might also contain statements generated by Db2. Each time that the function is invoked, the package executes one or more times.

When a CREATE FUNCTION statement for an SQL scalar function is processed, Db2 attempts to create an inlined SQL scalar function. If the function cannot be created as an inlined function, Db2 attempts to create a compiled SQL scalar function. For more information on the syntax and rules for these types of functions, see [“CREATE FUNCTION statement \(inlined SQL scalar function\)”](#) on page 1489 and [“CREATE FUNCTION statement \(compiled SQL scalar function\)”](#) on page 1428.

To determine what type of SQL scalar function is created, refer to the `INLINE` column of the `SYSIBM.SYSROUTINES` catalog table.

SQL table

The function is written exclusively as an SQL `RETURN` statement and returns a set of rows. The body of an SQL table function is written in the SQL procedural language. The function is defined at the current server along with various attributes. The function is not invoked as part of a query. Instead, the *expression* in the `RETURN` statement of the function is copied (inlined) into the query itself. Therefore, a package is not generated for an SQL table function. See [“CREATE FUNCTION statement \(SQL table function\)”](#) on page 1510.

Notes for all CREATE FUNCTION types

The following considerations apply for creating all types of functions:

Owner privileges:

For all functions except for sourced functions, the owner is authorized to execute the function (`EXECUTE` privilege) and has the ability to grant these privileges to others. For more information, see [“GRANT statement \(function or procedure privileges\)”](#) on page 1970. For more information about ownership of the object, see [“Authorization, privileges, permissions, masks, and object ownership”](#) on page 90.

Choosing the schema and function name:

The combination of name, schema name, the number of parameters, and the data type of each parameter (without regard for any length, precision, scale, subtype or encoding scheme attributes of the data type) must not identify a user-defined function that exists at the current server. If the function has more than 30 parameters, only the first 30 parameters are used to determine whether the function is unique.

You can use the same name for more than one function if the function signature of each function is unique.

- The unqualified form of *function-name* must not be any of the following system-reserved keywords even if you specify them as delimited identifiers:

ALL	LIKE	UNIQUE
AND	MATCH	UNKNOWN
ANY	NOT	=
BETWEEN	NULL	≠
DISTINCT	ONLY	<
EXCEPT	OR	<=
EXISTS	OVERLAPS	≠<
FALSE	SIMILAR	>
FOR	SOME	>=
FROM	TABLE	→>
IN	TRUE	<>
IS	TYPE	

The schema name can be `'SYSTOOLS'` or `'SYSFUN'` if the privilege set includes the `SYSADM` or `SYSCTRL` privilege. Otherwise, the schema name must not begin with `'SYS'` unless the schema name is `'SYSADM'`.

Defining the parameters

The input parameters for the function are specified as a list within parentheses.

A function can have no input parameters. In this case, an empty set of parentheses must be specified, for example:

```
CREATE FUNCTION WOOFER()
```

The data type of the result of the function is specified in the `RETURNS` clause for the function.

Choosing data types for parameters:

When you choose the data types of the input and output parameters for your function, consider the rules of promotion that can affect the values of the parameters. (See [“Promotion of data](#)

types” on page 129). For example, a constant that is one of the input arguments to the function might have a built-in data type that is different from the data type that the function expects, and more significantly, might not be promotable to that expected data type. Based on the rules of promotion, consider using the following data types for parameters:

- INTEGER instead of SMALLINT
- DOUBLE instead of REAL
- VARCHAR instead of CHAR
- VARGRAPHIC instead of GRAPHIC
- VARBINARY instead of BINARY

For portability of functions across platforms that are not Db2 for z/OS, do not use the following data types, which might have different representations on different platforms:

- FLOAT. Use DOUBLE or REAL instead.
- NUMERIC. Use DECIMAL instead.

Specifying AS LOCATOR for a parameter:

Passing a locator instead of a value can result in fewer bytes being passed in or out of the function. This can be useful when the value of the parameter is very large. The AS LOCATOR clause specifies that a locator to the value of the parameter is passed instead of the actual value. Specify AS LOCATOR only for parameters that have a LOB data type or a distinct type that is based on a LOB data type and only when LANGUAGE JAVA is not in effect.

The AS LOCATOR clause has no effect on determining whether data types can be promoted, nor does it affect the function signature, which is used in function resolution.

AS LOCATOR must not be specified for a sourced or SQL function.

AS LOCATOR must not be specified if the function is defined with NO SQL.

Considerations for a function that is defined using a TABLE LIKE name AS LOCATOR clause:

If a function is defined with a table parameter (the TABLE LIKE *name* AS LOCATOR clause was specified in the CREATE FUNCTION statement to indicate that one of the input parameters is a transition table), no ALTER FUNCTION statement that specifies a parameter list as part of the alteration can change the function. For example, a parameter list is required as part of the routine specification when adding or replacing a version of a function. In such cases, the function must be dropped and re-created..

Determining the uniqueness of functions in a schema:

At the current server, the function signature of each function, which is the qualified function name combined with the number and data types of the input parameters, must be unique. If the function has more than 30 input parameters, only the data types of the first 30 are used to determine uniqueness. This means that two different schemas can each contain a function with the same name that have the same data types for all of their corresponding data types. However, a single schema must not contain multiple functions with the same name that have the same data types for all of their corresponding data types.

When determining whether corresponding data types match, Db2 does not consider any length, precision, or scale attributes in the comparison. Db2 considers the synonyms of data types as a match. For example, REAL and FLOAT, and DOUBLE and FLOAT are considered a match. Therefore, CHAR(8) and CHAR(35) are considered to be the same, as are DECIMAL(11,2), DECIMAL(4,3), DECFLOAT(16) and DECFLOAT(34), TIMESTAMP(6) and TIMESTAMP(9), TIMESTAMP(6) WITH TIME ZONE and TIMESTAMP(9) WITH TIME ZONE. Furthermore, the character and graphic types, and the timestamp types are considered to be the same. For example, the following are considered to be the same type: CHAR and GRAPHIC, VARCHAR and VARGRAPHIC, CLOB and DBCLOB, TIMESTAMP WITHOUT TIME ZONE and TIMESTAMP WITH TIME ZONE. CHAR(13) and GRAPHIC(8) are considered to be the same type. An error is returned if the signature of the function being created is a duplicate of a signature for an existing user-defined function with the same name and schema.

Assume that the following statements are executed to create four functions in the same schema. The second and fourth statements fail because they create functions that are duplicates of the functions that the first and third statements created.

```
CREATE FUNCTION PART (INT, CHAR(15)) ...
CREATE FUNCTION PART (INTEGER, CHAR(40)) ...
CREATE FUNCTION ANGLE (DECIMAL(12,2)) ...
CREATE FUNCTION ANGLE (DEC(10,7)) ...
```

Specifying a specific name for a function:

When defining multiple functions with the same name and schema (with different parameter lists), it is recommended that a specific name also be specified.

The specific name can be used to uniquely identify the function such as when sourcing on this function, dropping the function, or commenting on the function. However, the function cannot be invoked by its specific name.

The specific name is implicitly or explicitly qualified with a schema name. If a schema name is not specified on CREATE FUNCTION, it is the same as the explicit or implicit schema name of the function name (function-name). If a schema name is specified, it must be the same as the explicit or implicit schema name of the function name. The name, including the schema name must not identify the specific name of another function or procedure that exists at the current server.

If the SPECIFIC clause is not specified, a specific name is generated.

Extending or overriding a built-in function

Giving a user-defined external function the same name as a built-in function is not a recommended practice unless the functionality of the built-in function needs to be extended or overridden.

If you do intend to create a function with the same name as a built-in function, be careful to maintain the uniqueness of its function signature. If your function has the same name and data types of the corresponding parameters of the built-in function but implements different logic, Db2 might choose the wrong function when the function is invoked with an unqualified function name. For example, If the schema for the new function appears in the SQL path before the system schemas, Db2 might choose a user-defined function rather than the built-in function. An application that uses the unqualified name and was previously successful using the built-in function of that name might fail. It might also appear to run successfully but provide a different result if Db2 chooses the built-in function instead of the user-defined function. This situation can occur with dynamic SQL statements, or when static SQL statements are rebound.

Extending the functionality of existing built-in functions

Create the new user-defined function with the same name as the built-in function, and a unique function signature. For example, a user-defined function similar to the built-in function ROUND that accepts the distinct type MONEY as input rather than the built-in numeric types might be necessary. In this case, the signature for the new user-defined function named ROUND is different from all the function signatures supported by the built-in ROUND function.

Overriding a built-in function:

Create the new user-defined function with the same name and signature as a built-in function. The new function has the same name and data type as the corresponding parameters of the built-in function but implements different logic.

For example, it might be useful to use different rules for rounding than the built-in ROUND function. In this case, the signature for the new user-defined function named ROUND will be the same as a signature that is supported by the built-in ROUND function.

Another case for overriding a built-in function is to use its functionality when an argument is not a built-in data type. Instead of explicitly casting the argument to a built-in data type, you can define a sourced function that accepts the user-defined data type argument and passes it to the underlying built-in function. A sourced function is defined with a reference to a built-in function or another user-defined function. For more information about sourced functions, see [“CREATE FUNCTION statement \(sourced function\)” on page 1498](#).

The DISTINCT keyword can be passed on the invocation of a user-defined function that is sourced on one of the built-in aggregate functions. For example, assume that MY_AVG is a user-defined function that is sourced on built-in AVG function. The user-defined function could be invoked with 'MY_AVG (DISTINCT *expression*)' This results in the underlying built-in AVG function being invoked with the DISTINCT keyword.

Special registers in functions

The settings of the special registers of the invoker are inherited by the function on invocation and restored upon return to the invoker. Special registers may be changed in a function that can execute SQL statements, but these changes do not affect the caller.

Global variables in functions:

The content of global variables that are referenced in a function are inherited from the invoking environment.

Scrollable cursors specified with user-defined functions:

A row can be fetched more than once with a scrollable cursor. Therefore, if a SELECT statement of a scrollable cursor invokes a function that is not deterministic in the select list, a row can be fetched multiple times with different results for each fetch. Similarly, if the SELECT statement of a scrollable cursor invokes a user-defined function defined with external action, the action is executed with every fetch.

Considerations for secure functions:

To create a secure function, the security administrator usually examines the data that is accessed by a function, ensures that it is secure, and grants the CREATE_SECURE_OBJECT privilege to someone who currently requires the privileges to create a secure user-defined function. After the function is created, they revoke the CREATE_SECURE_OBJECT privilege from the function owner.

A sourced function cannot be created as a secure function.

If a row permission or a column mask definition references a user-defined function, the user-defined function must be secure because the sensitive data might be passed as arguments to the function. The SECURE column in the DSN_FUNCTION_TABLE indicates whether a user-defined function is considered secure.

If a secure user-defined function invokes other user-defined functions, Db2 does not validate whether those nested user-defined functions have the SECURED attribute. If those nested functions can access sensitive data, the security administrator must ensure that those functions are allowed to access the sensitive data and should ensure that a change control audit procedure is established for all changes to those functions.

Related concepts

Functions

A *function* is an operation denoted by a function name followed by zero or more operands that are enclosed in parentheses. It represents a relationship between a set of input values and a set of result values.

Sample user-defined functions

Some sample user-defined functions are provided with Db2. You can use the functions in your applications just as you would use other user-defined functions, or as examples to help you define your own user-defined functions.

Related tasks

[Creating a user-defined function \(Db2 Application programming and SQL\)](#)

CREATE FUNCTION statement (compiled SQL scalar function)

The CREATE FUNCTION (compiled SQL scalar) statement defines a compiled SQL scalar function at the current server and specifies the source statements for the function. The body of the function is written in the SQL procedural language. The function returns a single value each time it is invoked.

A package is created for a compiled SQL scalar function.

For compiled SQL scalar functions, you can define multiple versions of the function. Use CREATE FUNCTION (compiled SQL scalar) to define the initial version, and ALTER FUNCTION to define subsequent versions. For information about the SQL statements that are supported in SQL functions, refer to [“SQL-procedure-statement \(SQL PL\)”](#) on page 2212.

Invocation for CREATE FUNCTION (compiled SQL scalar)

For a compiled SQL function, this statement can only be dynamically prepared but the DYNAMICRULES run behavior must be specified implicitly or explicitly.

Authorization for CREATE FUNCTION (compiled SQL scalar)

The privilege set defined below must include at least one of the following:

- The CREATEIN privilege on the schema and the required authorization to add a new package or a new version of an existing package, depending on the value of the BIND NEW PACKAGE field on installation panel DSNTIPP
- SYSADM or SYSCTRL authority
- System DBADM
- Installation SYSOPR authority (when the current SQLID of the process is set to SYSINSTL)

The authorization ID that matches the schema name implicitly has the CREATEIN privilege on the schema.

If the authorization ID that is used to create the function has the installation SYSADM authority or the installation SYSOPR authority and if the current SQLID is set to SYSINSTL, the function is identified as system-defined function.

If a user-defined type is referenced (as the data type of a parameter or an SQL variable), the privilege set must also include at least one of the following:

- Ownership of the user-defined type
- The USAGE privilege on the user-defined type
- SYSTEM DBADM authority
- DATAACCESS AUTHORITY
- SYSADM authority

If the function uses a table as a parameter, the privilege set must also include at least one of the following:

- Ownership of the table
- The SELECT privilege on the table
- DATAACCESS authority
- SYSADM authority

Additional authorization may be required on the SYSDUMMYx tables depending on the content of the function definition. See [SYSDUMMYx tables](#).

Privilege set: If the statement is embedded in an application program, the privilege set is the privileges that are held by the owner of the plan or package. If the package owner is a role, the implicit schema match does not apply and this role needs to include one of the previously listed conditions.

If the statement is dynamically prepared and is not running in a trusted context for which the ROLE AS OBJECT OWNER clause is specified, the privilege set is the set of privileges that are held by the SQL authorization ID of the process. If the schema name is not the same as the SQL authorization ID of the process, one of the following conditions must be met:

- The privilege set includes SYSADM or SYSCTRL authority.
- The SQL authorization ID of the process has the CREATEIN privilege on the schema.

When CREATE FUNCTION is issued in a trusted context that has the ROLE AS OBJECT OWNER clause, the package owner is determined as follows:

- If the PACKAGE OWNER option is not specified, the role associated with the binder becomes the package owner.
- If the PACKAGE OWNER option is specified, the role specified in the PACKAGE OWNER option becomes the package owner. In a trusted context, the PACKAGE OWNER specified must be a role.

If you specify the WLM ENVIRONMENT FOR DEBUG MODE clause, RACF or an external security product is invoked to check the required authority for defining programs in the WLM environment. If the WLM environment access is protected in RACF, the privilege set must include the required authority.

At least one of the following additional privileges is required if the SECURED option is specified

- SECADM authority
- CREATE_SECURE_OBJECT privilege

Syntax for CREATE FUNCTION (compiled SQL scalar)

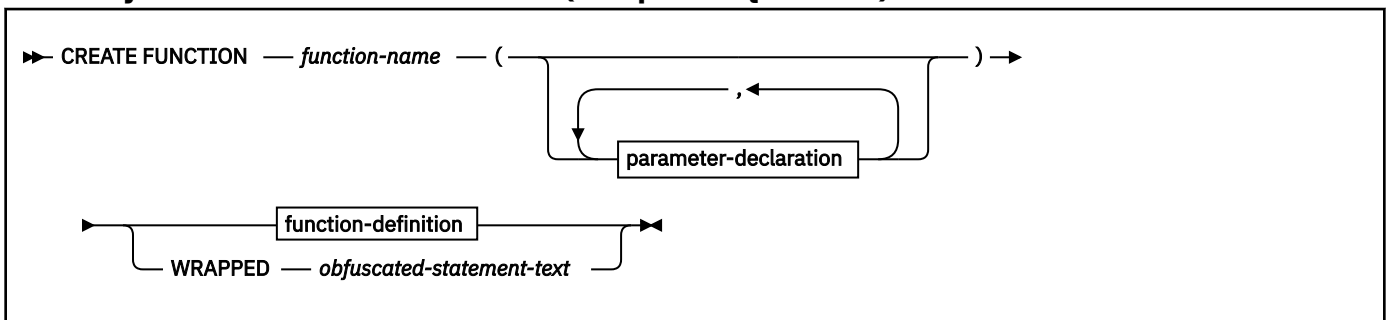

parameter-declaration:

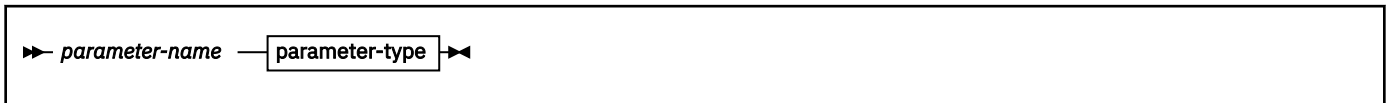

parameter-type:

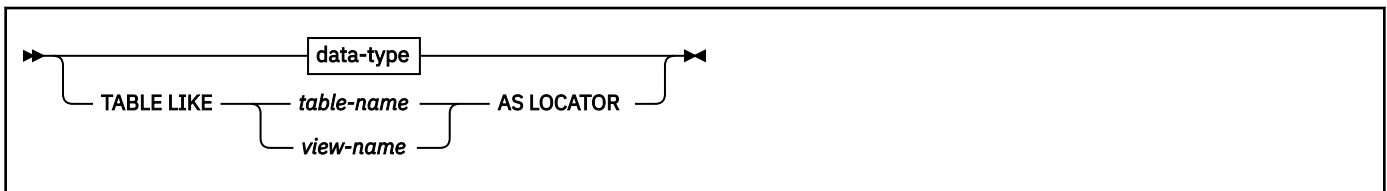

data-type:



built-in-type:

built-in-type:

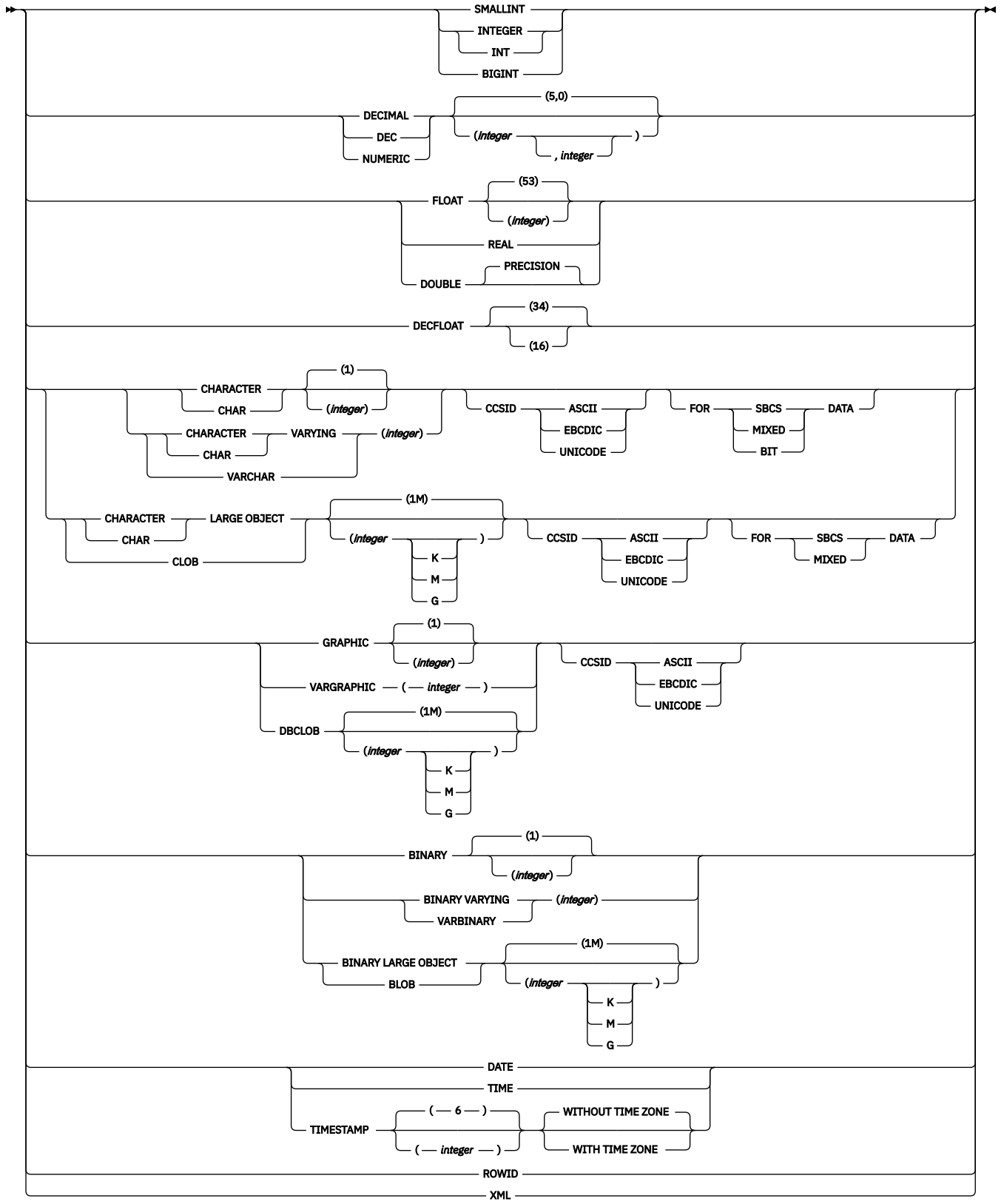

function-definition

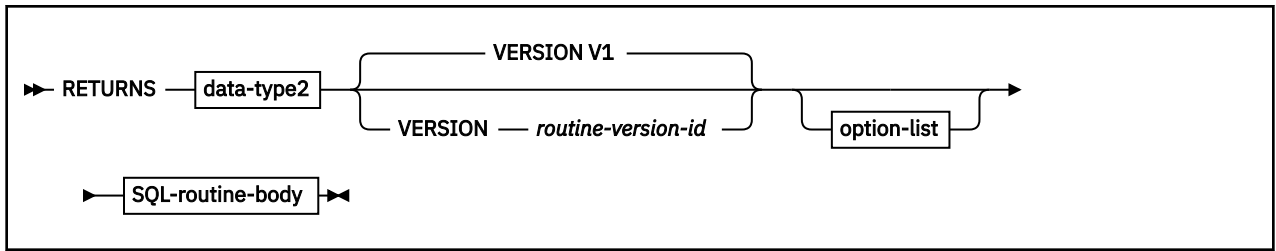

SQL-routine-body:



option-list: (The options in the *option-list* can be specified in any order, but each one can only be specified one time)

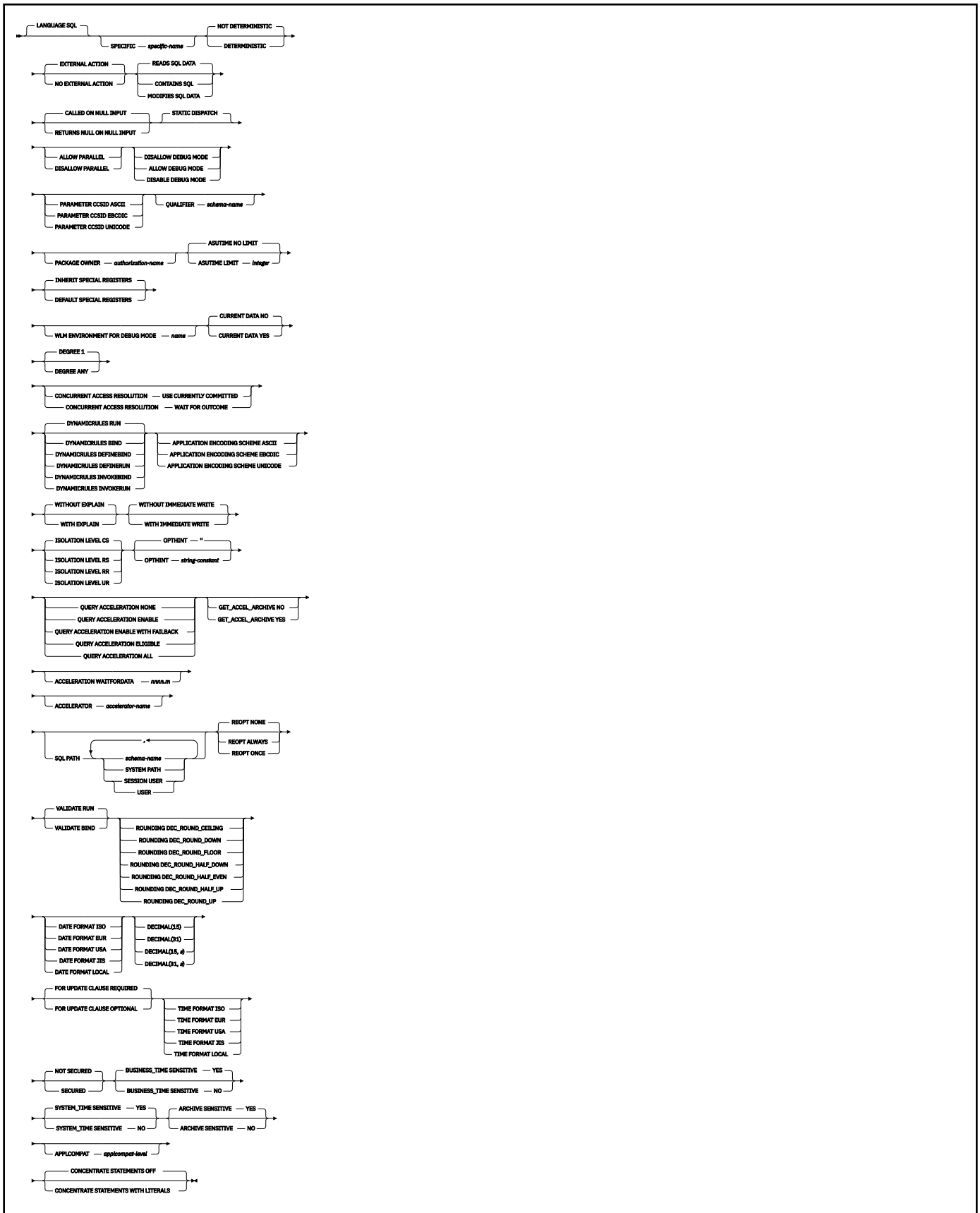

Description for CREATE FUNCTION (compiled SQL scalar)

function-name

Names the function. If *function-name* already exists with the specified signature, an error is returned even if VERSION is specified with a *routine-version-id* that is different from any existing version identifier for the function that is specified in *function-name*. For more information, see "Choosing the schema and function names" and "Determining the uniqueness of functions in a schema" in ["CREATE FUNCTION statement \(overview\)" on page 1424](#).

(parameter-declaration,...)

Specifies the number of input parameters of the function and the name and data type of each parameter. Each *parameter-declaration* specifies an input parameter for the function. A function can have zero or more input parameters. There must be one entry in the list for each parameter that the function expects to receive. All of the parameters for a function are input parameters and are nullable. If the function has more than 30 parameters, only the first 30 parameters are used to determine if the function is unique.

parameter-name

Specifies the name of the input parameter. The name is an SQL identifier, and each name in the parameter list must not be the same as any other name.

data-type

Specifies the data type of the input parameter. The data type can be a built-in data type or a user-defined type.

built-in-type

The data type of the input parameter is a built-in data type.

For information on the data types, see ["built-in-type" on page 1663](#).

For parameters with a character or graphic data type, the PARAMETER CCSID clause or CCSID clause indicates the encoding scheme of the parameter. If you do not specify either of these clauses, the encoding scheme is the value of field DEF ENCODING SCHEME on installation panel DSNTIPF.

distinct-type-name

The data type of the input parameter is a distinct type. Any length, precision, scale, subtype, or encoding scheme attributes for the parameter are those of the source type of the distinct type. The distinct type must not be based on a LOB data type.

If you specify the name of the distinct type without a schema name, Db2 resolves the distinct type by searching the schemas in the SQL path.

TABLE LIKE *table-name* AS LOCATOR

Specifies that the parameter is a transition table. However, when the function is invoked, the actual values in the transition table are not passed to the function. A single value is passed instead. This value is a locator for the table, which the function uses to access the columns of the transition table. The table that is identified can contain XML columns; however, the function cannot reference those XML columns.

A function with a table parameter can only be invoked from the triggered action of a trigger.

array-type-name

The data type of the input parameter is a user-defined array type.

If you specify *array-type-name* without a schema name, Db2 resolves the array type by searching the schemas in the SQL path.

The implicitly or explicitly specified encoding scheme of all of the parameters with a character or graphic string data type must be the same—either all ASCII, all EBCDIC, or all UNICODE.

Although parameters with a character data type have an implicitly or explicitly specified subtype (BIT, SBCS, or MIXED), the function program can receive character data of any subtype. Therefore, conversion of the input data to the subtype of the parameter might occur when the function is

invoked. An error occurs if mixed data that actually contains DBCS characters is used as the value for an input parameter that is declared with an SBCS subtype.

Parameters with a datetime data type or a distinct type are passed to the function as a different data type:

- A datetime type parameter is passed as a character data type, and the data is passed in ISO format.

The encoding scheme for a datetime type parameter is the same as the implicitly or explicitly specified encoding scheme of any character or graphic string parameters. If no character or graphic string parameters are passed, the encoding scheme is the value of field DEF ENCODING SCHEME on installation panel DSNTIPF.

- A distinct type parameter is passed as the source type of the distinct type.

RETURNS

Identifies the output of the function.

data-type2

Specifies the data type of the output. The output is nullable.

The same considerations that apply to the data type of input parameter, as described under [data-type](#), apply to the data type of the output of the function.

VERSION *routine-version-id*

Specifies the version identifier for the first version of the function that is to be generated. You can use an ALTER FUNCTION statement with the ADD VERSION clause or the BIND DEPLOY command to create additional versions of the function.

routine-version-id

An SQL identifier of up to 64 EBCDIC bytes that designates a version of a routine. The UTF-8 representation of the identifier must not exceed 122 bytes.

V1 is the default version identifier.

LANGUAGE SQL

Specifies that the function is written exclusively in SQL.

SPECIFIC *specific-name*

Specifies a unique name for the function. The name is implicitly or explicitly qualified with a schema name. The name, including the schema name, must not identify the specific name of another function that exists at the current server.

The unqualified form of *specific-name* is an SQL identifier. The qualified form is an SQL identifier (the schema name) followed by a period and an SQL identifier.

If you do not specify a schema name, it is the same as the explicit or implicit schema name of the function name (*function-name*). If you specify a schema name, it must be the same as the explicit or implicit schema name of the function name.

If you do not specify the SPECIFIC clause, the default specific name is the name of the function. However, if the function name does not provide a unique specific name or if the function name is a single asterisk, Db2 generates a specific name in the form of:

```
SQLxxxxxxxxxxxx
```

where 'xxxxxxxxxxxx' is a string of 12 characters that make the name unique.

The specific name is stored in the SPECIFIC column of the SYSROUTINES catalog table. The specific name can be used to uniquely identify the function in several SQL statements (such as ALTER FUNCTION, COMMENT, DROP, GRANT, and REVOKE) and must be used in Db2 commands (START FUNCTION, STOP FUNCTION, and DISPLAY FUNCTION). However, the function cannot be invoked by its specific name.

NOT DETERMINISTIC or DETERMINISTIC

Specifies whether the function returns the same results each time that the function is invoked with the same input arguments.

NOT DETERMINISTIC

The function might not return the same result each time that the function is invoked with the same input arguments. The function depends on some state values that affect the results. Db2 uses this information to disable the merging of views and table expressions when processing SELECT and SQL data change statements that refer to this function. An example of a function that is not deterministic is one that generates random numbers.

NOT DETERMINISTIC must be specified explicitly or implicitly if the function program accesses a special register or invokes another function that is not deterministic. NOT DETERMINISTIC is the default.

DETERMINISTIC

The function always returns the same result function each time that the function is invoked with the same input arguments. An example of a deterministic function is a function that calculates the square root of the input. Db2 uses this information to enable the merging of views and table expressions for SELECT and SQL data change statements that refer to this function. DETERMINISTIC is not the default. If applicable, specify DETERMINISTIC to prevent non-optimal access paths from being chosen for SQL statements that refer to this function.

Db2 does not verify that the function program is consistent with the specification of DETERMINISTIC or NOT DETERMINISTIC.

EXTERNAL ACTION or NO EXTERNAL ACTION

Specifies whether the function takes an action that changes the state of an object that Db2 does not manage. An example of an external action is sending a message or writing a record to a file.

EXTERNAL ACTION

The function can take an action that changes the state of an object that Db2 does not manage.

Some SQL statements that invoke functions with external actions can result in incorrect results if parallel tasks execute the function. For example, if the function sends a note for each initial call to it, one note is sent for each parallel task instead of once for the function. Specify the DISALLOW PARALLEL clause for functions that do not work correctly with parallelism.

If you specify EXTERNAL ACTION, then Db2:

- Materializes the views and table expressions in SELECT and SQL data change statements that refer to the function. This materialization can adversely affect the access paths that are chosen for the SQL statements that refer to this function. Do not specify EXTERNAL ACTION if the function does not have an external action.
- Does not move the function from one task control block (TCB) to another between FETCH operations.
- Does not allow another function or stored procedure to use the TCB until the cursor is closed. This is also applicable for cursors declared WITH HOLD.

The only changes to resources made outside of Db2 that are under the control of commit and rollback operations are those changes made under RRS control.

EXTERNAL ACTION must be specified implicitly or explicitly specified if the SQL routine body invokes a function that is defined with EXTERNAL ACTION. EXTERNAL ACTION is the default.

NO EXTERNAL ACTION

The function does not take any action that changes the state of an object that Db2 does not manage. Db2 uses this information to enable the merging of views and table expressions for SELECT and SQL data change statements that refer to this function. If applicable, specify NO EXTERNAL ACTION to prevent non-optimal access paths from being chosen for SQL statements that refer to this function.

Although the scope of global variables are beyond the scope of the routine, global variables can be set in the routine body when NO EXTERNAL ACTION is specified.

Db2 does not verify that the function program is consistent with the specification of EXTERNAL ACTION or NO EXTERNAL ACTION.

MODIFIES SQL DATA, READS SQL DATA, or CONTAINS SQL

Specifies the classification of SQL statements and nested routines that this routine can execute or invoke. The database manager verifies that the SQL statements issued by the function, and all routines locally invoked by the routine, are consistent with this specification; the verification is not performed when nested remote routines are invoked. For the classification of each statement, see Appendix D, “SQL statement data access classification for routines,” on page 2275.

MODIFIES SQL DATA

Specifies that the function can execute any SQL statement except the statements that are not supported in functions. Do not specify MODIFIES SQL DATA when ALLOW PARALLEL is in effect.

If a function that is defined with MODIFIES SQL DATA is invoked anywhere except the *select-clause* of the outermost SELECT statement, the results are unpredictable because the function can be invoked multiple times depending on the access plan that is used.

Recommendation: If a SELECT statement invokes a function that is defined with the MODIFIES SQL DATA option, ensure that statements nested inside the function do not modify objects that are referenced in any SQL statement at a higher level of nesting. Otherwise, unpredictable results are likely to occur.

READS SQL DATA

Specifies that the function can execute statements with a data access classification of READS SQL DATA, CONTAINS SQL, or NO SQL. The function cannot execute SQL statements that modify data.

READS SQL DATA is the default.

CONTAINS SQL

Specifies that the function can execute only SQL statements with a data access classification of CONTAINS SQL or NO SQL. The function cannot execute SQL statements that read or modify data.

CALLED ON NULL INPUT or RETURNS NULL ON NULL INPUT

Specifies whether the function is invoked if any of the input arguments is null at execution time.

CALLED ON NULL INPUT

Specifies that the function is to be invoked if any, or if all, of the argument values are null.

Specifying CALLED ON NULL INPUT means that the body of the function must be coded to test for null argument values.

CALLED ON NULL INPUT is the default.

RETURNS NULL ON NULL INPUT

Specifies that the function is not invoked and returns the null value if any of the input argument values is null.

STATIC DISPATCH

At function resolution time, Db2 chooses a function based on the static (or declared) types of the function parameters. STATIC DISPATCH is the default.

ALLOW PARALLEL or DISALLOW PARALLEL

Specifies if the function can be run in parallel. The default is DISALLOW PARALLEL, if you specify one or more of the following clauses:

- NOT DETERMINISTIC
- EXTERNAL ACTION
- MODIFIES SQL DATA

Otherwise, ALLOW PARALLEL is the default.

ALLOW PARALLEL

Specifies that the function can be run in parallel.

DISALLOW PARALLEL

Specifies that the function cannot be run in parallel.

ALLOW DEBUG MODE, DISALLOW DEBUG MODE, or DISABLE DEBUG MODE

Specifies whether this version of the routine can be run in debugging mode. The default is determined using the value of the CURRENT DEBUG MODE special register.

ALLOW DEBUG MODE

Specifies that this version of the routine can be run in debugging mode. When this version of the routine is invoked and debugging is attempted, a WLM environment must be available.

DISALLOW DEBUG MODE

Specifies that this version of the routine cannot be run in debugging mode.

You can use an ALTER statement to change this option to ALLOW DEBUG MODE for this initial version of the routine.

DISABLE DEBUG MODE

Specifies that this version of the routine can never be run in debugging mode.

This version of the routine cannot be changed to specify ALLOW DEBUG MODE or DISALLOW DEBUG MODE after this version of the routine has been created or altered to use DISABLE DEBUG MODE. To change this option, drop the routine and create it again using the option that you want. An alternative to dropping and recreating the routine is to create a version of the routine that uses the option that you want and making that version the active version.

When DISABLE DEBUG MODE is in effect, the WLM ENVIRONMENT FOR DEBUG MODE is ignored.

PARAMETER CCSID

Specifies that the encoding scheme for character or graphic string parameters is ASCII, EBCDIC, or UNICODE. The default encoding scheme is the value that is specified in the CCSID clauses of the parameter list or RETURNS clause, or in the DEF ENCODING SCHEME field on installation panel DSNTIPF.

This clause provides a convenient way to specify the encoding scheme for character or graphic string parameters. If individual CCSID clauses are specified for individual parameters in addition to this PARAMETER CCSID clause, the value that is specified in all of the CCSID clauses must be the same value that is specified in this clause. This clause also specifies the encoding scheme that is used for system-generated parameters of the routine, such as message tokens and DBINFO.

If the data type for a parameter is a user-defined distinct type that is defined as a character or graphic type string, the CCSID of the distinct type must be the same as the value that is specified in this clause.

If the data type for a parameter is a user-defined array type that is defined with character or graphic string array elements, or a character string array index, the CCSID of these array attributes must be the same as the value that is specified in this clause.

This clause also specifies the encoding scheme that will be used for system-generated parameters of the routine.

QUALIFIER *schema-name*

Specifies the implicit qualifier that is used for unqualified object names that are referenced in the procedure body. For information about how the default for this option is determined, see [“Unqualified alias, index, JAR file, mask, permission, sequence, table, trigger, and view names”](#) on page 86.

PACKAGE OWNER *authorization-name*

Specifies the owner of the package that is associated with the version of the routine. The SQL authorization ID of the process is the default value.

ASUTIME

Specifies the total amount of processor time, in CPU service units, that a single invocation of a routine can run. The value is unrelated to the ASUTIME column of the resource limit specification table.

When you are debugging a routine, setting a limit can be helpful in case the routine gets caught in a loop. For information on service units, see [z/OS MVS Initialization and Tuning Guide](#).

NO LIMIT

Specifies that there is no limit on the service units.

NO LIMIT is the default.

LIMIT *integer*

The limit on the number of CPU service units is a positive *integer* in the range 1–2 147 483 647. If the procedure uses more service units than the specified value, Db2 cancels the procedure. The CPU cycles that are consumed by parallel tasks in a procedure do not contribute towards the specified ASUTIME LIMIT.

INHERIT SPECIAL REGISTERS or DEFAULT SPECIAL REGISTERS

Specifies how special registers are set on entry to the routine.

INHERIT SPECIAL REGISTERS

Specifies that the values of special registers are inherited, according to the rules that are listed in the table for characteristics of special registers in a routine in [Table 47 on page 215](#).

INHERIT SPECIAL REGISTERS is the default.

DEFAULT SPECIAL REGISTERS

Specifies that special registers are initialized to the default values, as indicated by the rules in the table for characteristics of special registers in a routine in [Table 47 on page 215](#).

WLM ENVIRONMENT FOR DEBUG MODE *name*

Specifies the WLM (workload manager) application environment that is used by Db2 when debugging the routine. The *name* of the WLM environment is an SQL identifier.

If you do not specify WLM ENVIRONMENT FOR DEBUG MODE, Db2 uses the default WLM-established stored procedure address space specified at installation time.

You must have the appropriate authority for the WLM application environment.

The WLM ENVIRONMENT FOR DEBUG MODE value is ignored when DISABLE DEBUG MODE is in effect.

CURRENT DATA YES or CURRENT DATA NO

Specifies whether to require data currency for read-only and ambiguous cursors when the isolation level of cursor stability is in effect. CURRENT DATA also determines whether block fetch can be used for distributed, ambiguous cursors.

CURRENT DATA YES

Specifies that data currency is required for read-only and ambiguous cursors. Db2 acquired page or row locks to ensure data currency. Block fetch is ignored for distributed, ambiguous cursors.

CURRENT DATA NO

Specifies that data currency is not required for read-only and ambiguous cursors. Block fetch is allowed for distributed, ambiguous cursors. Use of CURRENT DATA NO is not recommended if the routine attempts to dynamically prepare and execute a DELETE WHERE CURRENT OF statement against an ambiguous cursor after that cursor is opened. You receive a negative SQLCODE if your routine attempts to use a DELETE WHERE CURRENT OF statement for any of the following cursors:

- A cursor that is using block fetch
- A cursor that is using query parallelism
- A cursor that is positioned on a row that is modified by this or another application process

CURRENT DATA NO is the default.

DEGREE

Specifies whether to attempt to run a query using parallel processing to maximize performance.

1

Specifies that parallel processing should not be used.

1 is the default.

ANY

Specifies that parallel processing can be used.

CONCURRENT ACCESS RESOLUTION

Specifies the whether processing uses only committed data or whether it will wait for commit or rollback of data that is in the process of being updated.

WAIT FOR OUTCOME

Specifies that processing will wait for the commit or rollback of data that is in the process of being updated.

USE CURRENTLY COMMITTED

Specifies that processing use the currently committed version of the data when data that is in the process of being updated is encountered. `USE CURRENTLY COMMITTED` is applicable on scans that access tables that are defined in universal table spaces with row or page level lock size.

When there is lock contention between a read transaction and an insert transaction, `USE CURRENTLY COMMITTED` is applicable to scans with isolation level CS or RS. Applicable scans include intent read scans for read-only and ambiguous queries and for updatable cursors. `USE CURRENTLY COMMITTED` is also applicable to scans initiated from `WHERE` predicates of `UPDATE` or `DELETE` statements and the subselect of `INSERT` statements.

When there is lock contention is between a read transaction and a delete transaction, `USE CURRENTLY COMMITTED` is applicable to scans with isolation level CS and when `CURRENT DATA NO` is specified.

DYNAMICRULES

Specifies the values that apply, at run time, for the following dynamic SQL attributes:

- The authorization ID that is used to check authorization
- The qualifier that is used for unqualified objects
- The source for application programming options that Db2 uses to parse and semantically verify dynamic SQL statements

`DYNAMICRULES` also specifies whether dynamic SQL statements can include `GRANT`, `REVOKE`, `ALTER`, `CREATE`, `DROP`, and `RENAME` statements.

In addition to the value of the `DYNAMICRULES` clause, the run time environment of a routine controls how dynamic SQL statements behave at run time. The combination of the `DYNAMICRULES` value and the run time environment determines the value for the dynamic SQL attributes. That set of attribute values is called the dynamic SQL statement behavior. The following values can be specified:

RUN

Specifies that dynamic SQL statements are to be processed using run behavior.

`RUN` is the default.

BIND

Specifies that dynamic SQL statements are to be processed using bind behavior.

DEFINEBIND

Specifies that dynamic SQL statements are to be processed using either define behavior or bind behavior.

DEFINERUN

Specifies that dynamic SQL statements are to be processed using either define behavior or run behavior.

INVOKEBIND

Specifies that dynamic SQL statements are to be processed using either invoke behavior or bind behavior.

INVOKERUN

Specifies that dynamic SQL statements are to be processed using either invoke behavior or run behavior.

See For information on the effects of these options, see [“Authorization IDs and dynamic SQL”](#) on page 94.

APPLICATION ENCODING SCHEME

Specifies the default encoding scheme for SQL variables in static SQL statements in the routine body. The value is used for defining an SQL variable in a compound statement if the CCSID clause is not specified as part of the data type, and the PARAMETER CCSID routine option is not specified.

ASCII

Specifies that the data is encoded using the ASCII CCSIDs of the server.

EBCDIC

Specifies that the data is encoded using the EBCDIC CCSIDs of the server.

UNICODE

Specifies that the data is encoded using the Unicode CCSIDs of the server.

See the ENCODING bind option in [ENCODING bind option \(Db2 Commands\)](#) for information about how the default for this option is determined.

WITH EXPLAIN or WITHOUT EXPLAIN

Specifies whether information will be provided about how SQL statements in the routine will execute.

WITHOUT EXPLAIN

Specifies that information will not be provided about how SQL statements in the routine will execute.

You can get EXPLAIN output for a statement that is embedded in a routine that is specified using WITHOUT EXPLAIN by embedding the SQL statement EXPLAIN in the routine body. Otherwise, the value of the EXPLAIN option applies to all explainable SQL statements in the routine body, and to the fullselect portion of any DECLARE CURSOR statements.

WITHOUT EXPLAIN is the default.

WITH EXPLAIN

Specifies that information will be provided about how SQL statements in the routine will execute. Information is inserted into the table *owner.PLAN_TABLE*. *owner* is the authorization ID of the owner of the routine. Alternatively, the authorization ID of the owner of the routine can have an alias as *owner.PLAN_TABLE* that points to the base table, *PLAN_TABLE*. *owner* must also have the appropriate SELECT and INSERT privileges on that table. WITH EXPLAIN does not obtain information for statements that access remote objects. *PLAN_TABLE* must have a base table and can have multiple aliases with the same table name, *PLAN_TABLE*, but have different schema qualifiers. It cannot be a view or a synonym and should exist before the CREATE statement is processed. In all inserts to *owner.PLAN_TABLE*, the value of QUERYNO is the statement number that is assigned by Db2.

The WITH EXPLAIN option also populates two optional tables, if they exist: *DSN_STATEMNT_TABLE* and *DSN_FUNCTION_TABLE*. *DSN_STATEMNT_TABLE* contains an estimate of the processing cost for an SQL statement and *DSN_FUNCTION_TABLE* contains information about function resolution. For more information, see [EXPLAIN tables \(Db2 Performance\)](#).

For more information about the EXPLAIN statement, including a description of the tables that are populated by the WITH EXPLAIN option, see [“EXPLAIN statement” on page 1917](#).

WITH IMMEDIATE WRITE or WITHOUT IMMEDIATE WRITE

Specifies whether immediate writes are to be done for updates that are made to group buffer pool dependent page sets or partitions. This option is only applicable for data sharing environments. The IMMEDIATEWRITE subsystem parameter has no effect of this option. [IMMEDIATEWRITE bind option \(Db2 Commands\)](#) shows the implied hierarchy of the IMMEDIATEWRITE bind option (which is similar to this routine option) as it affects run time.

WITHOUT IMMEDIATE WRITE

Specifies that normal write activity is performed. Updated pages that are group buffer pool dependent are written at or before phase one of commit or at the end of abort for transactions that have been rolled back.

WITHOUT IMMEDIATE WRITE is the default.

WITH IMMEDIATE WRITE

Specifies that updated pages that are group buffer pool dependent are immediately written as soon as the buffer update completes. Updated pages are written immediately even if the buffer is updated during forward progress or during the rollback of a transaction. WITH IMMEDIATE WRITE might impact performance.

ISOLATION LEVEL RR, RS, CS, or UR

Specifies how far to isolate the routine from the effects of other running applications. For information about isolation levels, see [Choosing an ISOLATION option \(Db2 Performance\)](#).

RR

Specifies repeatable read.

RS

Specifies read stability.

CS

Specifies cursor stability. CS is the default.

UR

Specifies uncommitted read.

OPTHINT 'hint-id'

Specifies whether query optimization hints are used for static SQL statements that are contained within the body of the routine.

hint-id is a character string of up to 128 bytes in length, which is used by the Db2 subsystem when searching the PLAN_TABLE for rows to use as input. The default value is an empty string (''), which indicates that the Db2 subsystem does not use optimization hints for static SQL statements.

Optimization hints are only used if optimization hints are enabled for your system. For more information, see [OPTIMIZATION HINTS field \(OPTHINTS subsystem parameter\) \(Db2 Installation and Migration\)](#).

SQL PATH

Specifies the SQL path that the Db2 subsystem uses to resolve unqualified user-defined data types, functions, and procedure names (in CALL statements) in the body of the routine. The default value is "SYSIBM", "SYSFUN", "SYSPROC", "SYSIBMADM", and the value of the QUALIFIER option, which is the qualifier for the trigger that is the target of the statement. The maximum length of the SQL path is 2048 bytes. Db2 calculates the length by taking each *schema-name* that is specified and removing any trailing blanks from it, adding a delimiter on the left and right sides, and adding one comma after each schema name except for the last name. The length of the resulting string cannot exceed 2048 bytes.

schema-name

Identifies a schema. Db2 does not verify that the schema exists when the CREATE statement is processed. The same schema name should not appear more than one time in the list of schema names.

SYSPUBLIC must not be specified for the SQL path.

SYSTEM PATH

Specifies the schema names "SYSIBM", "SYSFUN", "SYSPROC", "SYSIBMADM".

SESSION_USER or USER

Specifies the value of the SESSION_USER (or USER) special register. At the time the CREATE statement is processed, the actual length is included in the total length of the list of schema names that is specified for the SQL PATH option.

REOPT

Specifies if Db2 will determine the access path at run time by using the values of SQL variables or SQL parameters, parameter markers, and special registers.

NONE

Specifies that Db2 does not determine the access path at run time by using the values of SQL variables or SQL parameters, parameter markers, and special registers.

NONE is the default.

ALWAYS

Specifies that Db2 always determines the access path at run time each time an SQL statement is run. Do not specify REOPT ALWAYS with the WITH KEEP DYNAMIC or NODEFER PREPARE clauses.

ONCE

Specifies that Db2 determine the access path for any dynamic SQL statements only once, at the first time the statement is opened. This access path is used until the prepared statement is invalidated or removed from the dynamic statement cache and need to be prepared again.

QUERY ACCELERATION

Specifies whether a static SQL query is bound for acceleration, and if so, with what behavior.

NONE

Specifies that no static SQL query in the application is bound for acceleration or will be accelerated when the application is run.

ENABLE

Specifies that a static SQL query is bound for acceleration if it satisfies the acceleration criteria, including the cost and heuristics criteria. The query is routed to an accelerator when the application runs. Otherwise, if the static query does not satisfy the acceleration criteria, the query is bound for execution in Db2.

If an error condition, such as one of the following examples, occurs while executing the accelerated static query when the application is run, Db2 fails the static query and returns a negative SQL code to the application:

- A failure occurs while running the static query on the accelerator.
- The accelerator returns an error for the query.
- The accelerator is not started and Db2 cannot route the static query to the accelerator for execution.

ENABLE WITH FAILBACK

Results in the same behavior as ENABLE, except if one of the error conditions occurs on the first OPEN of the accelerated static query when the application is run. In this case, instead of failing the static query and returning a negative SQL code to the application, Db2 performs a temporary *statement-level* incremental bind of the query and runs the query in Db2. The application does not see the acceleration failure. Failback to Db2 is not possible after the application does a successful OPEN for the query on the accelerator.

ELIGIBLE

Specifies that a static SQL query is bound for acceleration if the query meets the basic acceleration criteria, regardless of the cost or heuristics criteria. The query is routed to the accelerator when the application runs.

Like the behavior for ENABLE, if an error condition occurs while executing the accelerated static query when the application is run, Db2 fails the static query and returns a negative SQL code to the application.

ALL

Specifies that all of the static SQL queries in the application are to be bound for acceleration and routed to the accelerator when the application runs. If Db2 determines that a static query cannot be bound to run on the accelerator and the query references a user base table or view, the BIND or REBIND PACKAGE operation fails with an error message for that query. (A failure exception is made for declared global temporary tables (DGTs) and created global temporary tables and (CGTs) because these tables cannot be accelerated.)

Like the behavior for ENABLE, if an error condition occurs while executing the accelerated static query when the application is run, Db2 fails the static query and returns a negative SQL code to the application.

This bind option does not apply to a *fullselect* or *WITH common-table-expression* that is specified in a RETURN statement for the routine, or in a SET *host-variable-assignment* that is used in the routine. The queries that are specified in these cases cannot be accelerated.

GET_ACCEL_ARCHIVE

Specifies whether a static SQL query that is bound for acceleration retrieves archived data on the accelerator, instead of active data.

NO

Specifies that no static SQL query is bound to retrieve archived data from the accelerator. If the static query also is not bound for acceleration, the query is bound to run in Db2.

If the static query is bound for acceleration because the QUERYACCELERATION bind option was specified, the query is routed to the accelerator when the application runs; however, the query does not retrieve any archived data.

YES

Specifies that if all of the following criteria are met, the query is bound for acceleration and retrieves the archived data on the accelerator when the application runs:

- The QUERYACCELERATION bind option is also specified.
- The static SQL query references an accelerated table that has partitioned data archived on an accelerator.
- The static query satisfies the acceleration criteria that is specified by the QUERYACCELERATION bind option.

If the static query does not satisfy the acceleration criteria that is specified by the QUERYACCELERATION bind option, the BIND or REBIND PACKAGE operation fails with an error message for that query.

This bind option does not apply to a *fullselect* or *WITH common-table-expression* that is specified in a RETURN statement for the routine, or in a SET *host-variable-assignment* that is used in the routine. The queries that are specified in these cases cannot be accelerated.

ACCELERATION WAITFORDATA

Specifies the maximum amount of time, if any, that an accelerator will delay a query while the accelerator waits for the replication of committed Db2 data changes that occurred prior to Db2 running the query.

For static accelerated queries, you must also set the QUERYACCELERATION bind option for this function or procedure to a valid value other than NONE to request that static queries be accelerated. If the QUERYACCELERATION bind option value is set to NONE, the ACCELERATIONWAITFORDATA bind option is accepted and the package is bound with the option value; however, the option will not apply to static SQL queries because no static queries will be accelerated.

For dynamic accelerated queries, specifying the ACCELERATION WAITFORDATA bind option also initializes the CURRENT QUERY ACCELERATION WAITFORDATA special register, which is used for the dynamic queries in the Db2 function or procedure if the function or procedure option DEFAULT SPECIAL REGISTERS is also used. Initializing CURRENT QUERY ACCELERATION WAITFORDATA to a value greater than 0 specifies that Db2 and the accelerator will apply WAITFORDATA delay behavior and restrictions to all dynamic SQL queries to be accelerated from the Db2 function or procedure. The CURRENT QUERY ACCELERATION special register must also have a valid value other than NONE to request that dynamic queries be accelerated.

nnnn.m

Specifies a DECIMAL(5,1) numeric-constant value that specifies the maximum number of seconds that the accelerator will delay a query while the accelerator waits for the replication of committed Db2 data changes that occurred prior to Db2 running the query.

You can specify a value in the range of 0.0–3600.0 seconds. For example, a value of 20.0 represents 20.0 seconds (or 20000 milliseconds), and a value of 30.5 represents 30.5 seconds (or 30500 milliseconds). The maximum value of 3600.0 means they the query is delayed for 3600 seconds.

You can also specify the value as an INTEGER numeric-constant value ranging 0–3600 seconds, which Db2 will convert to a DECIMAL(5,1) value.

Important: When a non-zero value is specified for the ACCELERATIONWAITFORDATA bind option, Db2 and the accelerator will apply other WAITFORDATA delay behaviors, restrictions, and requirements to all queries that will be accelerated from the application package. These behaviors, restrictions, and requirements can cause queries that were formerly accelerated successfully to no longer be accelerated or to fail. See [“SET CURRENT QUERY ACCELERATION WAITFORDATA statement”](#) on page 2150 for more information about WAITFORDATA behaviors, restrictions, and requirements.

ACCELERATOR

Specifies an accelerator server that, if enabled and available, Db2 will consider as the preferred accelerator for eligible SQL queries before sending the queries to other accelerator servers. If the specified accelerator server is not enabled or available, Db2 will send the queries to other available accelerator servers.

VALIDATE RUN or VALIDATE BIND

Specifies whether to recheck, at run time, errors of the type "OBJECT NOT FOUND" and "NOT AUTHORIZED" that are found during bind or rebind. The option has no effect if all objects and needed privileges exist.

VALIDATE RUN

Specifies that if needed objects or privileges do not exist when the CREATE statement is processed, warning messages are returned, but the CREATE statement succeeds. The Db2 subsystem rechecks for the objects and privileges at run time for those SQL statements that failed the checks during processing of the CREATE statement. The authorization checks the use of the authorization ID of the owner of the routine.

VALIDATE RUN is the default.

VALIDATE BIND

Specifies that if needed objects or privileges do not exist at the time the CREATE statement is processed, an error is issued and the CREATE statement fails.

ROUNDING

Specifies the rounding mode for manipulation of DECFLOAT data. The default value is taken from the DEFAULT DECIMAL FLOATING POINT ROUNDING MODE in DECP.

DEC_ROUND_CEILING

Specifies numbers are rounded towards positive infinity.

DEC_ROUND_DOWN

Specifies numbers are rounded towards 0 (truncation).

DEC_ROUND_FLOOR

Specifies numbers are rounded towards negative infinity.

DEC_ROUND_HALF_DOWN

Specifies numbers are rounded to nearest; if equidistant, round down.

DEC_ROUND_HALF_EVEN

Specifies numbers are rounded to nearest; if equidistant, round so that the final digit is even.

DEC_ROUND_HALF_UP

Specifies numbers are rounded to nearest; if equidistant, round up.

DEC_ROUND_UP

Specifies numbers are rounded away from 0.

DATE FORMAT ISO, EUR, USA, JIS, or LOCAL

Specifies the date format for result values that are string representations of date or time values. For more information, see [“String representations of datetime values”](#) on page 120.

The default format is specified in the DATE FORMAT field of installation panel DSNTIP4 of the system where the routine is defined. You cannot use the LOCAL option unless you have a date exit routine.

DECIMAL (15), DECIMAL (31), DECIMAL (15, s), or DECIMAL (31, s)

Specifies the maximum precision that is to be used for decimal arithmetic operations. For more information see [“Arithmetic with two decimal operands”](#) on page 251. The default format is specified in the DECIMAL ARITHMETIC field of installation panel DSNTIPF of the system where the routine is defined. If the form *pp.s* is specified, *s* must be a number in the range 1–9. *s* represents the minimum scale that is to be used for division.

FOR UPDATE CLAUSE OPTIONAL or FOR UPDATE CLAUSE REQUIRED

Specifies whether the FOR UPDATE clause is required for a DECLARE CURSOR statement if the cursor is to be used to perform positioned updates.

FOR UPDATE CLAUSE REQUIRED

Specifies that a FOR UPDATE clause must be specified as part of the cursor definition if the cursor will be used to make positioned updates.

FOR UPDATE CLAUSE REQUIRED is the default.

FOR UPDATE CLAUSE OPTIONAL

Specifies that the FOR UPDATE clause does not need to be specified in order for a cursor to be used for positioned updates. The routine body can include positioned UPDATE statements that update columns that the user is authorized to update.

The FOR UPDATE clause with no column list applies to static or dynamic SQL statements. Even if you do not use this clause, you can specify FOR UPDATE OF with a column list to restrict updates to only the columns that are identified in the FOR UPDATE clause and to specify the acquisition of update locks.

TIME FORMAT ISO, EUR, USA, JIS, or LOCAL

Specifies the time format for result values that are string representations of date or time values. For more information, see [“String representations of datetime values”](#) on page 120.

The default format is specified in the TIME FORMAT field of installation panel DSNTIP4 of the system where the routine is defined. You cannot use the LOCAL option unless you have a date exit routine.

NOT SECURED or SECURED

Specifies if the function is considered secure for row access control and column access control. The SECURED or NOT SECURED option applies to all future versions of the function.

NOT SECURED

Specifies that the function is not considered secure for row access control and column access control.

NOT SECURED is the default.

When the function is invoked, the arguments of the function must not reference a column for which a column mask is enabled when the table is using active column access control.

SECURED

Specifies that the function is considered secure for row access control and column access control.

The function must be secure when it is referenced in a row permission or a column mask.

BUSINESS_TIME SENSITIVE

Determines whether references to application-period temporal tables in both static and dynamic SQL statements are affected by the value of the CURRENT TEMPORAL BUSINESS_TIME special register.

YES

References to application-period temporal tables are affected by the value of the CURRENT TEMPORAL BUSINESS_TIME special register. YES is the default value.

NO

References to application-period temporal tables are not affected by the value of the CURRENT TEMPORAL BUSINESS_TIME special register.

For more information, see [“CURRENT TEMPORAL BUSINESS_TIME special register”](#) on page 208.

SYSTEM_TIME SENSITIVE

Determines whether references to system-period temporal tables in both static and dynamic SQL statements are affected by the value of the CURRENT TEMPORAL SYSTEM_TIME special register.

YES

References to system-period temporal tables are affected by the value of the CURRENT TEMPORAL SYSTEM_TIME special register. YES is the default value.

NO

References to system-period temporal tables are not affected by the value of the CURRENT TEMPORAL SYSTEM_TIME special register.

For more information, see [“CURRENT TEMPORAL SYSTEM_TIME special register”](#) on page 210.

ARCHIVE SENSITIVE

Determines whether references to archive-enabled tables in SQL statements are affected by the value of the SYSIBMADM.GET_ARCHIVE built-in global variable.

YES

References to archive-enabled tables are affected by the value of the SYSIBMADM.GET_ARCHIVE built-in global variable. YES is the default value.

NO

References to archive-enabled tables are not affected by the value of the SYSIBMADM.GET_ARCHIVE built-in global variable.

For related information, see [“GET_ARCHIVE”](#) on page 330

APPLCOMPAT *applcompat-level*

Specifies the application compatibility level behavior for static SQL statements in the package. If this option is not specified, the behavior is determined by the APPLCOMPAT subsystem parameter. The following *applcompat-level* values can be specified:

VvvRrMmmm

Compatibility with the behavior of the identified Db2 function level. For example, V12R1M510 specifies compatibility with the highest available Db2 12 function level. The equivalent function level or higher must be activated.

For the new capabilities that become available in each application compatibility level, see:

- [SQL changes in Db2 13 application compatibility levels](#)
- [SQL changes in Db2 12 application compatibility levels](#)

Tip: Extra program preparation steps might be required to increase the application compatibility level for applications that use data server clients or drivers to access Db2 for z/OS. For more information, see [Setting application compatibility levels for data server clients and drivers \(Db2 Application programming and SQL\)](#).

V12R1

Compatibility with the behavior of Db2 12 function level 500. This value has the same result as specifying V12R1M500.

V11R1

Compatibility with the behavior of Db2 11 new-function mode. After migration to Db2 12, this value has the same result as specifying V12R1M100. For more information, see [V11R1 application compatibility level \(Db2 Application programming and SQL\)](#)

V10R1

Compatibility with the behavior of DB2 10 new-function mode. For more information, see [V10R1 application compatibility level \(Db2 Application programming and SQL\)](#).

CONCENTRATE STATEMENTS OFF or CONCENTRATE STATEMENTS WITH LITERALS

Specifies whether each dynamic SQL statement in the routine that specifies literal constants will be cached as a separate unique statement entry in the dynamic statement cache, instead of sharing an

existing statement in the cache. Dynamic SQL statements are eligible to share an existing statement in the cache if the new statement meets all of the conditions for sharing a cached version of the same dynamic statement, except that the new statement specifies one or more literal constants that are different than the cached statement.

CONCENTRATE STATEMENTS OFF

Specifies that each dynamic SQL statement that specifies literal constants will be cached as a unique statement entry if it specifies one or more constants that are different than the cached version of the same dynamic statement. **CONCENTRATE STATEMENTS OFF** is the default dynamic statement caching behavior.

CONCENTRATE STATEMENTS WITH LITERALS

Specifies that each dynamic SQL statement that specifies literal constants will share a cached version of the same dynamic statement that is also prepared using the **CONCENTRATE STATEMENTS WITH LITERALS** option, if the new dynamic statement meets all of the conditions for sharing the cached statement, and the constants that are specified can be reused in place of the constants in the cached statement.

SQL-routine-body

Specifies a single SQL control statement, including a compound-statement. See [Chapter 8, “SQL procedural language \(SQL PL\),” on page 2207](#) for more information about defining SQL functions.

An error is issued if an SQL function calls a procedure and the procedure issues a **COMMIT**, **ROLLBACK**, **CONNECT**, **RELEASE**, or **SET CONNECTION** statement.

If the *SQL-routine-body* is a compound statement, it must contain at least one **RETURN** statement and a **RETURN** statement must be executed when the function is invoked.

SQL-routine-body must not contain a period specification or period clause.

An **ALTER FUNCTION** (compiled SQL scalar) statement or an **ALTER PROCEDURE** (SQL native) statement with an **ADD VERSION** clause or a **REPLACE** clause is not allowed in an *SQL-routine-body*.

WRAPPED *obfuscated-statement-text*

Specifies the encoded definition of the function. A **CREATE FUNCTION** statement can be encoded using the **WRAP** scalar function.

WRAPPED must not be specified on a static **CREATE** statement.

Notes for CREATE FUNCTION (compiled SQL scalar)

Considerations for all types of user-defined functions:

For considerations that apply to all types of user-defined functions, see [“CREATE FUNCTION statement \(overview\)” on page 1424](#).

Types of SQL scalar functions:

If the syntax of the **CREATE FUNCTION** statement conforms to the syntax diagrams and descriptions for **CREATE FUNCTION** (inlined SQL scalar), Db2 defines an inlined function, and a package is not created. When an inlined SQL scalar function is invoked, the *expression* in the **RETURN** statement of the function is copied (inlined) into the query itself; the function is not invoked. The attributes of an inlined SQL scalar function are described in [“CREATE FUNCTION statement \(inlined SQL scalar function\)” on page 1489](#).

Otherwise, Db2 attempts to define a compiled function with an associated package. For example, if the **RETURN** statement contains a scalar fullselect, Db2 attempts to define a compiled function. The attributes of a compiled SQL scalar function are described in [“CREATE FUNCTION statement \(compiled SQL scalar function\)” on page 1428](#).

To determine what type of SQL scalar function is created, refer to the **INLINE** column of the **SYSIBM.SYSROUTINES** catalog table. In the **INLINE** column, a value of **Y** indicates that the function is an inlined function, and a value of **N** indicates that the function is a compiled function.

Considerations for functions defined with MODIFIES SQL DATA:

If a function is specified in a subselect, and the function is defined as `MODIFIES SQL DATA`, the number of times the function is invoked will vary depending on the access plan used.

Self-referencing function:

The body of an SQL function (that is, the *expression* or `NULL` in the `RETURN` statement in the body of the `CREATE FUNCTION` statement) cannot contain a recursive invocation of itself or to another function that invokes it, because such a function would not exist to be referenced.

Dependent objects:

An SQL routine is dependent on objects that are referenced in the routine body.

Obfuscated statements:

A `CREATE FUNCTION` statement can be executed in obfuscated form. In an obfuscated statement, only the function name, parameters, and the `WRAPPED` keyword are readable. The rest of the statement is encoded in such a way that it is not readable but can be decoded by a database server that supports obfuscated statements. The `WRAP` scalar function produces obfuscated statements. Any debug options that are specified when the function is created from an obfuscated statement are ignored.

Identifier resolution:

See Chapter 8, “SQL procedural language (SQL PL),” on page 2207 for information on how names are resolved to columns, variables, or SQL parameters within an SQL routine.

If duplicate names are used for columns, variables, and parameters, qualify the duplicate names by using the table designator for columns, the routine name for parameters, the label name for SQL variables, and the schema name for global variables.

Error handling in SQL functions:

You should consider the possible exceptions that can occur for each SQL statement in the body of a compiled SQL function. Any exception `SQLSTATE` that is not handled within the function (using a handler), results in the exception `SQLSTATE` being returned for the SQL statement that caused the function to be invoked.

Lines within the SQL function definition:

When a compiled SQL function is created, information is retained on lines in the `CREATE` statement. Lines are determined by the presence of the new line control character.

In a compiled SQL scalar function, a *new line control character* is a special character that is used for a new line. The new line control characters for a compiled SQL scalar function include:

- Line feed
- New line
- Carriage return
- Carriage return, followed by a line feed
- Carriage return, followed by a new line

For more information about control characters, see “Characters and tokens in SQL” on page 75.

Considerations for SQL processor programs:

SQL processor programs, such as `SPUFI`, the command line processor, and `DSNTEP2`, might not correctly parse SQL statements in the routine body that end with semicolons. These processor programs accept multiple SQL statements as input, with each statement separated with a terminator character. Processor programs that use a semicolon as the SQL statement terminator can truncate a `CREATE FUNCTION` statement with embedded semicolons and pass only a portion of it to Db2. Therefore, you might need to change the SQL terminator character for these processor programs. For information on changing the terminator character for `SPUFI` and `DSNTEP2`, see [Setting the SQL terminator character in a SPUFI input data set \(Db2 Application programming and SQL\)](#).

Considerations for packages:

A package is generated for compiled SQL scalar functions. The package that is associated with the first version of a function is named as follows:

- *location* is set to the value of the `CURRENT SERVER` special register.

- *collection-id* (schema) for the package is the same as the schema qualifier of the function.
- *package-id* is the same as the specific name of the function.
- *version-id* is the same as the version identifier for the initial version of the function.

The package is generated using the bind options that correspond to the implicitly or explicitly specified function options. In addition to the corresponding bind options, the package is generated using the following bind options:

- FLAG(I)
- SQLERROR(NOPACKAGE)
- ENABLE(*)

Correspondence of function options to bind command options:

The following table lists options for CREATE FUNCTION and ALTER FUNCTION and the corresponding bind command option. See [BIND and REBIND options for packages, plans, and services \(Db2 Commands\)](#) for information about the BIND command options.

<i>Table 195. Correspondence of function options to bind options</i>	
CREATE FUNCTION or ALTER FUNCTION option	bind command option
ACCELERATION WAITFOR DATA <i>nnnn.m</i>	ACCELERATIONWAITFOR DATA(<i>nnnn.m</i>)
ACCELERATOR <i>accelerator-name</i>	ACCELERATOR(<i>accelerator-name</i>)
APPLICATION ENCODING SCHEME ASCII	ENCODING(ASCII)
APPLICATION ENCODING SCHEME EBCDIC	ENCODING(EBCDIC)
APPLICATION ENCODING SCHEME UNICODE	ENCODING(UNICODE)
ARCHIVE SENSITIVE NO	ARCHIVESENSITIVE(NO)
ARCHIVE SENSITIVE YES	ARCHIVESENSITIVE(YES)
BUSINESS_TIME SENSITIVE NO	BUSTIMESENSITIVE(NO)
BUSINESS_TIME SENSITIVE YES	BUSTIMESENSITIVE(YES)
CURRENT DATA NO	CURRENTDATA(NO)
CURRENT DATA YES	CURRENTDATA(YES)
DYNAMICRULES RUN	DYNAMICRULES(RUN)
DYNAMICRULES BIND	DYNAMICRULES(BIND)
DYNAMICRULES DEFINE BIND	DYNAMICRULES(DEFINE BIND)
DYNAMICRULES DEFINER RUN	DYNAMICRULES(DEFINER RUN)
DYNAMICRULES INVOKE BIND	DYNAMICRULES(INVOKE BIND)
DYNAMICRULES INVOKER RUN	DYNAMICRULES(INVOKER RUN)
GET_ACCEL_ARCHIVE NO	GETACCELARCHIVE(NO)
GET_ACCEL_ARCHIVE YES	GETACCELARCHIVE(YES)
ISOLATION LEVEL CS	ISOLATION(CS)
ISOLATION LEVEL RS	ISOLATION(RS)
ISOLATION LEVEL RR	ISOLATION(RR)
ISOLATION LEVEL UR	ISOLATION(UR)
OPTHINT <i>string-constant</i>	OPTHINT(<i>hint-id</i>)

<i>Table 195. Correspondence of function options to bind options (continued)</i>	
CREATE FUNCTION or ALTER FUNCTION option	bind command option
PACKAGE OWNER <i>authorization-name</i>	OWNER(<i>authorization-id</i>)
QUALIFIER <i>schema-name</i>	QUALIFIER(<i>qualifier-name</i>)
QUERY ACCELERATION NONE	QUERYACCELERATION(NONE)
QUERY ACCELERATION ENABLE	QUERYACCELERATION(ENABLE)
QUERY ACCELERATION ENABLE WITH FAILBACK	QUERYACCELERATION(ENABLE WITH FAILBACK)
QUERY ACCELERATION ELIGIBLE	QUERYACCELERATION(ELIGIBLE)
QUERY ACCELERATION ALL	QUERYACCELERATION(ALL)
REOPT ALWAYS	REOPT(ALWAYS)
REOPT NONE	REOPT(NONE)
REOPT ONCE	REOPT(ONCE)
ROUNDING DEC_ROUND_CEILING	ROUNDING(CEILING)
ROUNDING DEC_ROUND_DOWN	ROUNDING(DOWN)
ROUNDING DEC_ROUND_FLOOR	ROUNDING(FLOOR)
ROUNDING DEC_ROUND_HALF_DOWN	ROUNDING(HALFDOWN)
ROUNDING DEC_ROUND_HALF_EVEN	ROUNDING(HALFEVEN)
ROUNDING DEC_ROUND_HALF_UP	ROUNDING(HALFUP)
ROUNDING DEC_ROUND_UP	ROUNDING(UP)
SQL PATH <i>path-specification</i>	PATH(<i>path-specification</i>)
SYSTEM_TIME SENSITIVE NO	SYSTIMESENSITIVE(NO)
SYSTEM_TIME SENSITIVE YES	SYSTIMESENSITIVE(YES)
VALIDATE BIND	VALIDATE(BIND)
VALIDATE RUN	VALIDATE(RUN)
WITH EXPLAIN	EXPLAIN(YES)
WITHOUT EXPLAIN	EXPLAIN(NO)
WITH IMMEDIATE WRITE	IMMEDWRITE(YES)
WITHOUT IMMEDIATE WRITE	IMMEDWRITE(NO)

Application compatibility level considerations for function objects

The application compatibility level controls the adoption and use of new capabilities and enhancements. When an object is created or altered, two separate application compatibility levels are used: one to process the definition of the object, and the other for processing the SQL statements in the object body:

Object definition	The CURRENT APPLICATION COMPATIBILITY special register value is used to process the object definition, except for statements in the object body
--------------------------	---

	<p>This application compatibility level is stored in the SYSENVIRONMENT.APPLCOMPAT column. You can use the environment ID value in the catalog definition of the object to locate the SYSENVIRONMENT row with the matching ENVID value.</p> <p>This application compatibility level can be changed when the object is regenerated.</p>
Statements in the object body	<p>The application compatibility level that is implicitly or explicitly specified with the APPLCOMPAT option of the CREATE or ALTER statement is used to process statements in the object body.</p> <p>This application compatibility level is stored in the SYSPACKAGE.APPLCOMPAT column for the package associated with the object definition.</p>

Deploying a compiled SQL scalar function:

When a BIND DEPLOY command is issued to deploy a compiled SQL scalar function to a target location, the SECURED and NOT SECURED options are included in the deployment process.

When deploying a compiled SQL scalar function, if a function with the same target name does not exist at the target location, the deployed function is created as a new function at the target location with the same SECURED or NOT SECURED option that is specified (or the default of NOT SECURED is used) in the source of the deployment.

When deploying a compiled SQL scalar function, if a function with the same target name already exists at the target location, the deployed function is either added as a new version of the function, or the deployed function is used to replace an existing version of the function. The SECURED or NOT SECURED option of the deployed function must be the same as that of the existing function at the target location.

Versions of a function:

The CREATE FUNCTION statement for an SQL function defines the initial version of the function. You can define additional versions using the ADD VERSION clause of the ALTER FUNCTION statement. All versions of a function share the same function signature and the same specific name. However, the parameters names can differ between versions of a functions. Only one version of the function can be considered to be the active version of the function.

Alternative syntax and synonyms:

To provide compatibility with previously releases of Db2 or other products in the Db2 family, Db2 supports the following alternative syntax:

- VARIANT as a synonym for NOT DETERMINISTIC
- NOT VARIANT as a synonym for DETERMINISTIC
- NOT NULL CALL as a synonym for RETURNS NULL ON NULL INPUT
- NULL CALL as a synonym for CALLED ON NULL INPUT
- TIMEZONE can be specified as an alternative to TIME ZONE.

Example for CREATE FUNCTION (compiled SQL scalar)

Define a scalar function that returns the text of an input string, in reverse order:

```
CREATE FUNCTION REVERSE(INSTR VARCHAR(4000))
  RETURNS VARCHAR(4000)
  DETERMINISTIC NO EXTERNAL ACTION CONTAINS SQL
  BEGIN
  DECLARE REVSTR, RESTSTR VARCHAR(4000) DEFAULT '';
  DECLARE LEN INT;
  IF INSTR IS NULL THEN
  RETURN NULL;
```



```

END IF;
SET (RESTSTR, LEN) = (INSTR, LENGTH(INSTR));
WHILE LEN > 0 DO
SET (REVSTR, RESTSTR, LEN)
= (SUBSTR(RESTSTR, 1, 1) CONCAT REVSTR,
SUBSTR(RESTSTR, 2, LEN - 1),
LEN - 1);
END WHILE;
RETURN REVSTR;
END#

```

Related concepts

[SQL scalar functions \(Db2 Application programming and SQL\)](#)

[Naming conventions](#)

The rules for forming a name depend on the type of the object designated by the name.

Related tasks

[Creating a user-defined function \(Db2 Application programming and SQL\)](#)

CREATE FUNCTION statement (external scalar function)

This CREATE FUNCTION statement registers a user-defined external scalar function with a database server. A scalar function returns a single value each time it is invoked.

Invocation for CREATE FUNCTION (external scalar)

This statement can be embedded in an application program or issued interactively. It is an executable statement that can be dynamically prepared only if DYNAMICRULES RUN behavior is in effect. For more information, see [“Authorization IDs and dynamic SQL” on page 94](#).

Authorization for CREATE FUNCTION (external scalar)

The privilege set defined below must include at least one of the following:

- The CREATEIN privilege on the schema
- SYSADM or SYSCTRL authority
- System DBADM
- Installation SYSOPR authority (when the current SQLID of the process is set to SYSINSTL)

The authorization ID that matches the schema name implicitly has the CREATEIN privilege on the schema.

If the authorization ID that is used to create the function has the installation SYSADM authority or the installation SYSOPR authority and if the current SQLID is set to SYSINSTL, the function is identified as system-defined function.

Additional privileges are required if the function uses a table as a parameter, refers to a distinct type, or is to run in a WLM (workload manager) environment. These privileges are:

- The SELECT privilege on any table that is an input parameter to the function.
- The USAGE privilege on each distinct type that the function references.
- Authority to create programs in the specified WLM environment. This authorization is obtained from an external security product, such as RACF. For more information, see [Managing authorizations for creation of stored procedures in WLM environments \(Managing Security\)](#).

At least one of the following additional privileges is required if the SECURED option is specified

- SECADM authority
- CREATE_SECURE_OBJECT privilege

When LANGUAGE is JAVA and a *jar-name* is specified in the EXTERNAL NAME clause, the privilege set must include USAGE on the JAR file.

Privilege set: If the statement is embedded in an application program, the privilege set is the privileges that are held by the owner of the plan or package. If the owner is a role, the implicit schema match does not apply and this role needs to include one of the previously listed conditions.

If the statement is dynamically prepared and is not running in a trusted context for which the ROLE AS OBJECT OWNER clause is specified, the privilege set is the set of privileges that are held by the SQL authorization ID of the process. If the schema name is not the same as the SQL authorization ID of the process, one of the following conditions must be met:

- The privilege set includes SYSADM or SYSCTRL authority.
- The SQL authorization ID of the process has the CREATEIN privilege on the schema.

Syntax for CREATE FUNCTION (external scalar)

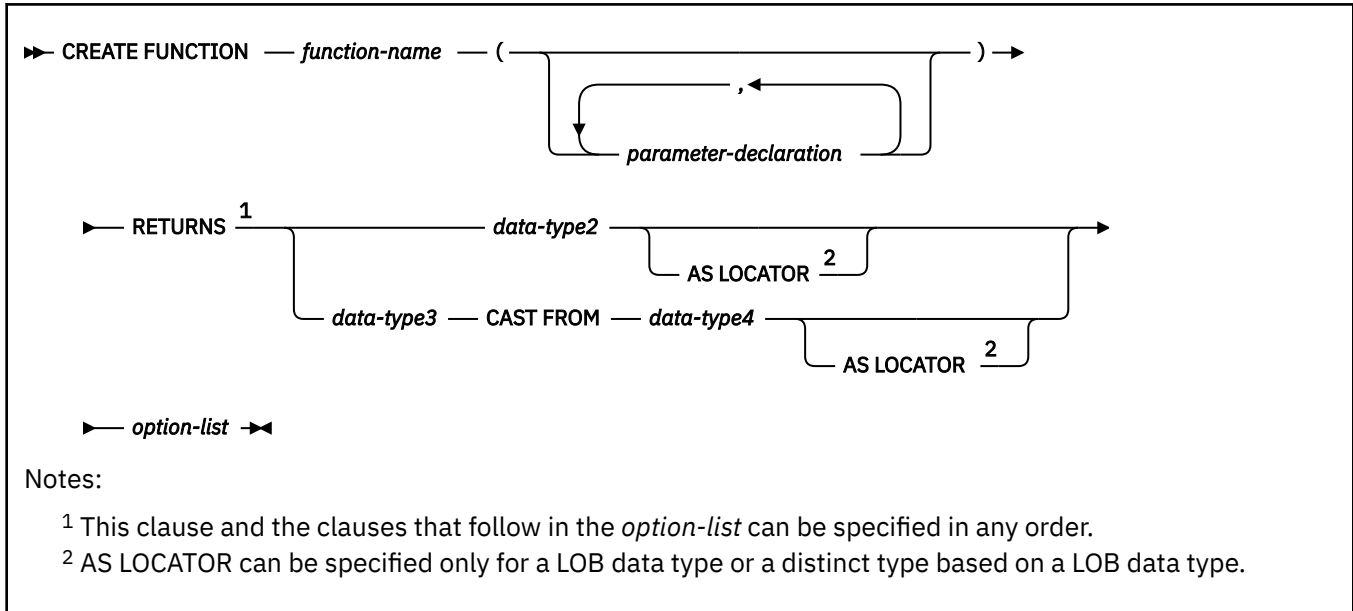

parameter-declaration:

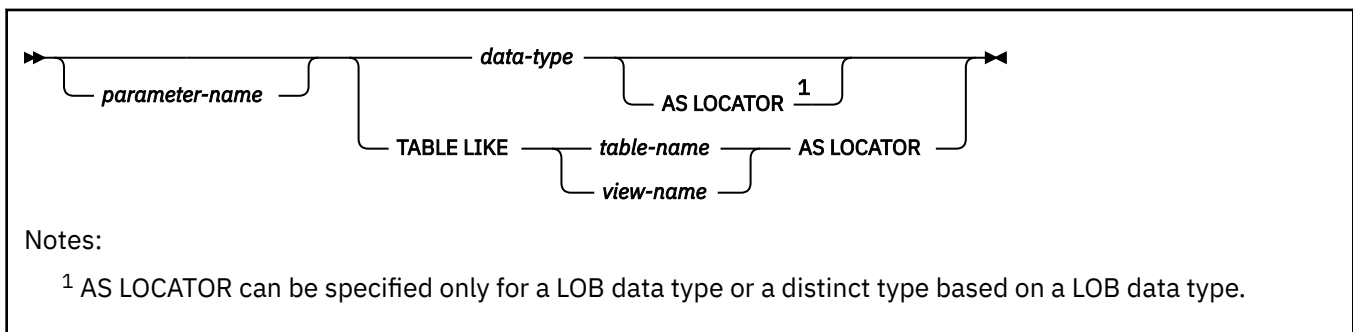

data-type:



built-in-type:

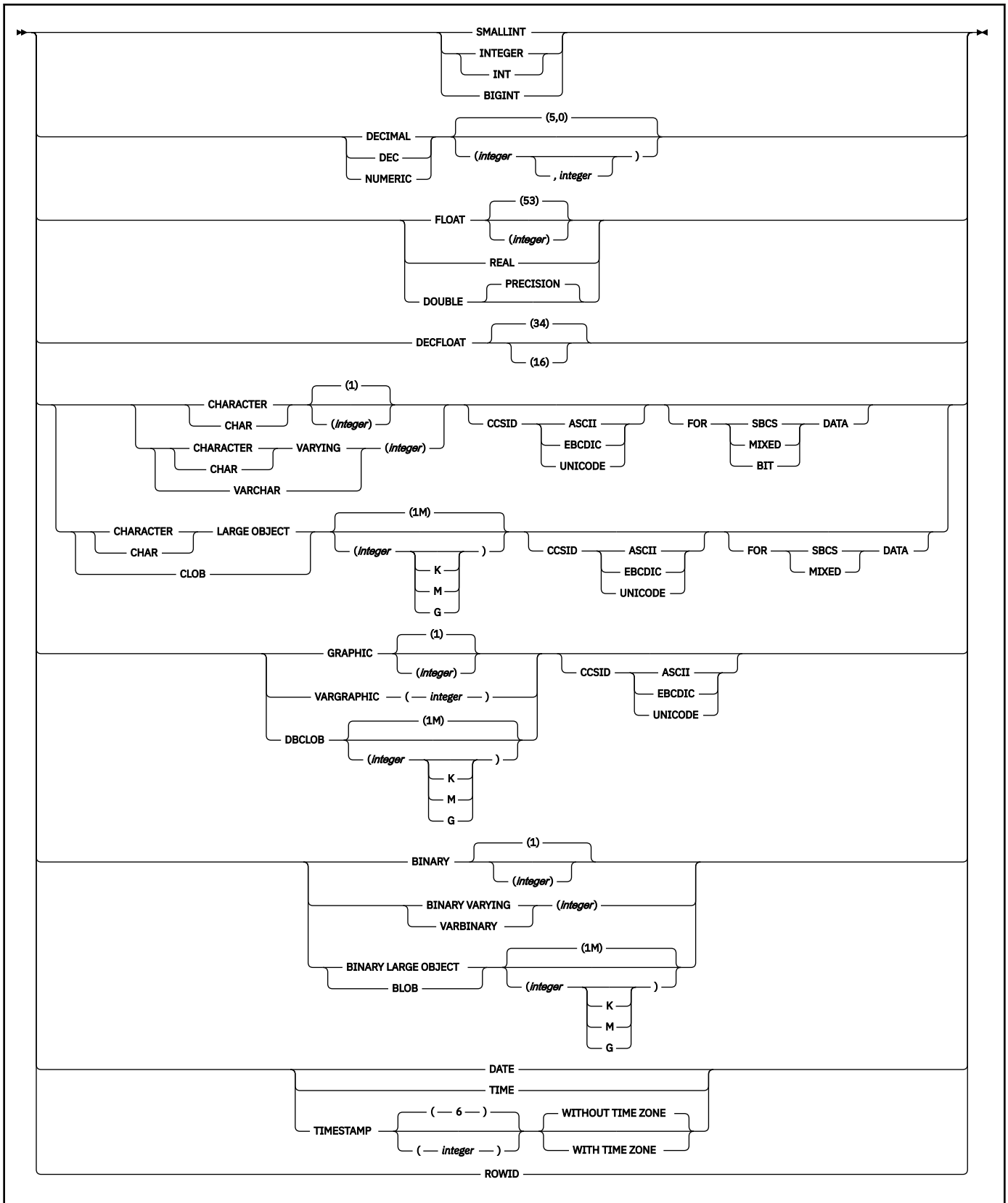

option-list: (The clauses in the option list can be specified in any order)

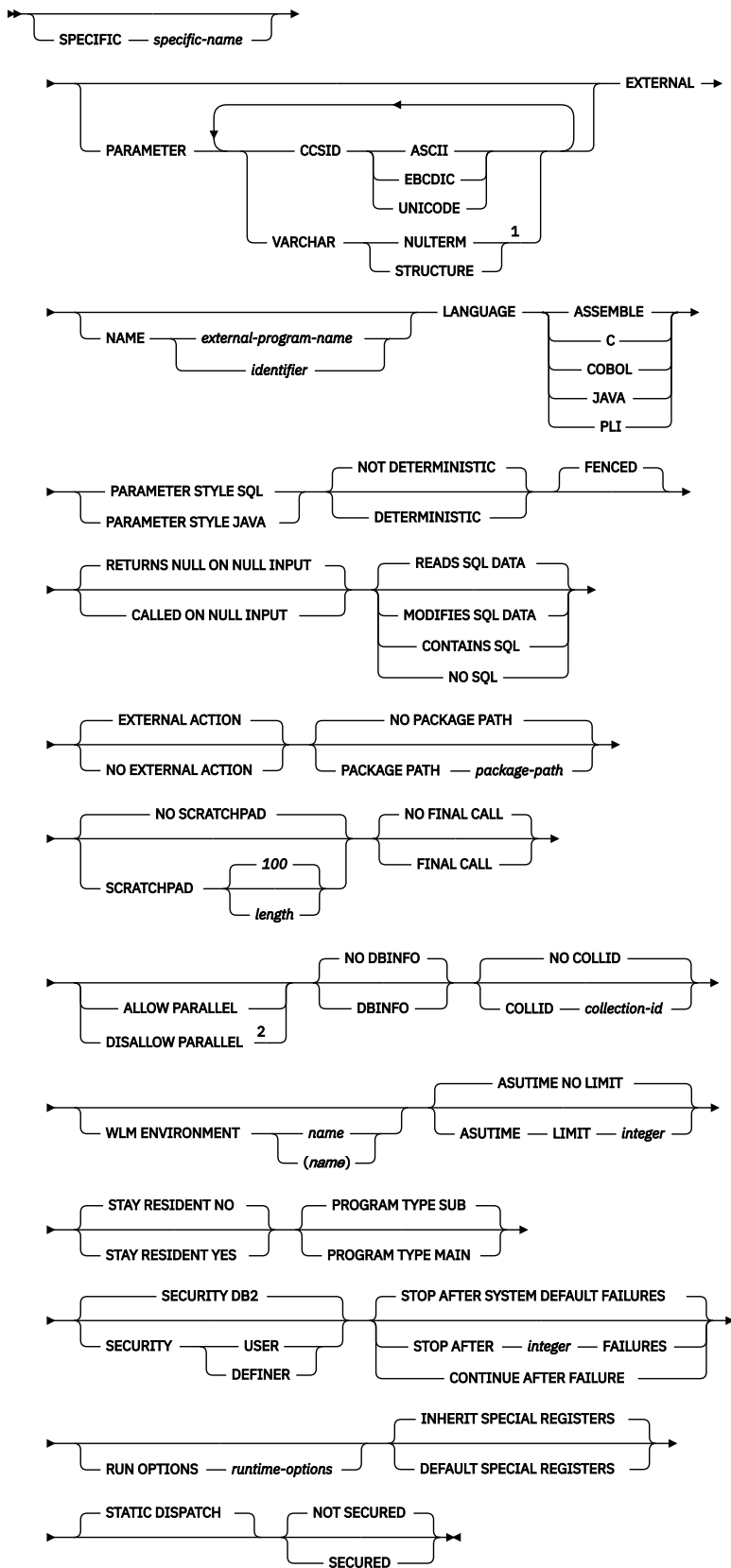

Notes:

¹ The same clause must not be specified more than one time.

² If NOT DETERMINISTIC, EXTERNAL ACTION, SCRATCHPAD, or FINAL CALL is specified, DISALLOW PARALLEL is the default.

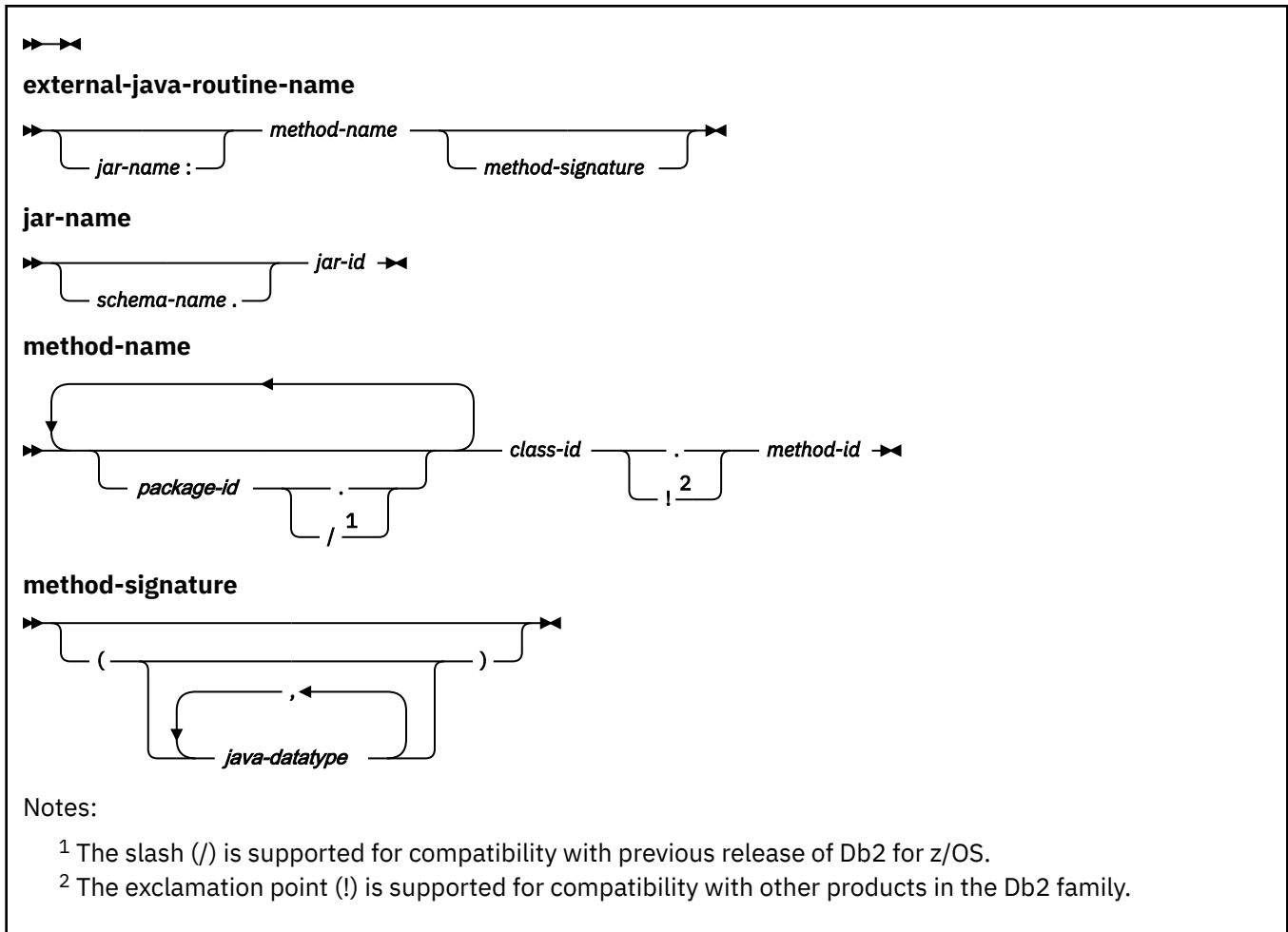

Description for CREATE FUNCTION (external scalar)

function-name

Names the user-defined function. The name is implicitly or explicitly qualified by a schema name. For more information, see "Choosing the schema and function names" and "Determining the uniqueness of functions in a schema" in ["CREATE FUNCTION statement \(overview\)"](#) on page 1424.

(parameter-declaration,...)

Identifies the number of input parameters of the function, and specifies the data type of each parameter. All of the parameters for a function are input parameters and are nullable. There must be one entry in the list for each parameter that the function expects to receive. Although not required, you can give each parameter a name.

A function can have no parameters. In this case, you must code an empty set of parentheses, for example:

```
CREATE FUNCTION WOOFER()
```

parameter-name

Specifies the name of the input parameter. The name is an SQL identifier, and each name in the parameter list must not be the same as any other name.

data-type

Specifies the data type of the input parameter. The data type can be a built-in data type or a distinct type.

built-in-type

The data type of the input parameter is a built-in data type.

For information on the data types, see [built-in-type](#).

For parameters with a character or graphic data type, the PARAMETER CCSID clause or CCSID clause indicates the encoding scheme of the parameter. If you do not specify either of these clauses, the encoding scheme is the value of field DEF ENCODING SCHEME on installation panel DSNTIPF.

distinct-type-name

The data type of the input parameter is a distinct type. Any length, precision, scale, subtype, or encoding scheme attributes for the parameter are those of the source type of the distinct type.

If you specify the name of the distinct type without a schema name, Db2 resolves the schema name by searching the schemas in the SQL path.

The implicitly or explicitly specified encoding scheme of all of the parameters with a character or graphic string data type must be the same—either all ASCII, all EBCDIC, or all UNICODE.

Although parameters with a character data type have an implicitly or explicitly specified subtype (BIT, SBCS, or MIXED), the function program can receive character data of any subtype. Therefore, conversion of the input data to the subtype of the parameter might occur when the function is invoked. An error occurs if mixed data that actually contains DBCS characters is used as the value for an input parameter that is declared with an SBCS subtype.

Parameters with a datetime data type or a distinct type are passed to the function as a different data type:

- A datetime type parameter is passed as a character data type, and the data is passed in ISO format.

The encoding scheme for a datetime type parameter is the same as the implicitly or explicitly specified encoding scheme of any character or graphic string parameters. If no character or graphic string parameters are passed, the encoding scheme is the value of field DEF ENCODING SCHEME on installation panel DSNTIPF.

- A distinct type parameter is passed as the source type of the distinct type.

AS LOCATOR

Specifies that a locator to the value of the parameter is passed to the function instead of the actual value. Specify AS LOCATOR only for parameters with a LOB data type or a distinct type based on a LOB data type. Passing locators instead of values can result in fewer bytes being passed to the function, especially when the value of the parameter is very large.

The AS LOCATOR clause has no effect on determining whether data types can be promoted, nor does it affect the function signature, which is used in function resolution.

TABLE LIKE *table-name* or *view-name* AS LOCATOR

Specifies that the parameter is a transition table. However, when the function is invoked, the actual values in the transition table are not passed to the function. A single value is passed instead. This single value is a locator to the table, which the function uses to access the columns of the transition table. A function with a table parameter can only be invoked from the triggered action of a trigger.

The use of TABLE LIKE provides an implicit definition of the transition table. It specifies that the transition table has the same number of columns as the identified table or view. If a table is specified, the transition table includes columns that are defined as implicitly hidden in the table. The columns have the same data type, length, precision, scale, subtype, and encoding scheme as the identified table or view, as they are described in catalog tables SYSCOLUMNS and SYSTABLESPACE. The number of columns and the attributes of those columns are determined at the time the CREATE FUNCTION statement is processed. Any subsequent changes to the number of columns in the table or the attributes of those columns do not affect the parameters of the function.

table-name or *view-name* must identify a table or view that exists at the current server. A view cannot have columns of length 0. The name must not identify a declared temporary table. The table that is identified can contain XML columns; however, the function cannot reference those

XML columns. The name does not have to be the same name as the table that is associated with the transition table for the trigger. An unqualified table or view name is implicitly qualified according to the following rules:

- If the CREATE FUNCTION statement is embedded in a program, the implicit qualifier is the authorization ID in the QUALIFIER bind option when the plan or package was created or last rebound. If QUALIFIER was not used, the implicit qualifier is the owner of the plan or package.
- If the CREATE FUNCTION statement is dynamically prepared, the implicit qualifier is the SQL authorization ID in the CURRENT SCHEMA special register.

When the function is invoked, the corresponding columns of the transition table identified by the table locator and the table or view identified in the TABLE LIKE clause must have the same definition. The data type, length, precision, scale, and encoding scheme of these columns must match exactly. The description of the table or view at the time the CREATE FUNCTION statement was executed is used.

Additionally, a character FOR BIT DATA column of the transition table cannot be passed as input for a table parameter for which the corresponding column of the table specified at the definition is not defined as character FOR BIT DATA. (The definition occurs with the CREATE FUNCTION statement.) Likewise, a character column of the transition table that is not FOR BIT DATA cannot be passed as input for a table parameter for which the corresponding column of the table specified at the definition is defined as character FOR BIT DATA.

For more information about using table locators, see [Accessing transition tables in a user-defined function or stored procedure \(Db2 Application programming and SQL\)](#).

RETURNS

Specifies the data type for the result of the function. Consider this clause in conjunction with the optional CAST FROM clause.

data-type2

Specifies the data type of the output. The output parameter is nullable.

The same considerations that apply to the data type and nullability of input parameter, as described under [data-type](#), apply to the data type of the result of the function.

AS LOCATOR

Specifies that the function returns a locator to the value rather than the actual value. You can specify AS LOCATOR only if the output from the function has a LOB data type or a distinct type based on a LOB data type.

data-type3* CAST FROM *data-type4

Specifies the data type of the output of the function (*data-type4*) and the data type in which that output is returned to the invoking statement (*data-type3*). The two data types can be different. For example, for the following definition, the function returns a DOUBLE value, which Db2 converts to a DECIMAL value and then passes to the statement that invoked the function:

```
CREATE FUNCTION SQRT(DECIMAL(15,0))
  RETURNS DECIMAL(15,0) CAST FROM DOUBLE
  ...
```

The value of *data-type4* can be any built-in data type and must be castable to *data-type3*. The value for *data-type3* can be any built-in data type. (For information on casting data types, see [“Casting between data types” on page 130](#).) The encoding scheme of the parameters, if they are string data types, must be the same.

If the PARAMETER VARCHAR clause is specified, *data-type3* and *data-type4* should be specified as VARCHAR.

AS LOCATOR

Specifies that the function returns a locator to the value rather than the value. You can specify AS LOCATOR only if *data-type4* is a LOB data type or a distinct type based on a LOB data type.

SPECIFIC *specific-name*

Specifies a unique name for the function. The name is implicitly or explicitly qualified with a schema name. The name, including the schema name, must not identify the specific name of another function that exists at the current server.

The unqualified form of *specific-name* is an SQL identifier. The qualified form is an SQL identifier (the schema name) followed by a period and an SQL identifier.

If you do not specify a schema name, it is the same as the explicit or implicit schema name of the function name (*function-name*). If you specify a schema name, it must be the same as the explicit or implicit schema name of the function name.

If you do not specify the SPECIFIC clause, the default specific name is the name of the function. However, if the function name does not provide a unique specific name or if the function name is a single asterisk, Db2 generates a specific name in the form of:

```
SQLxxxxxxxxxxxxx
```

where 'xxxxxxxxxxxxx' is a string of 12 characters that make the name unique.

The specific name is stored in the SPECIFIC column of the SYSROUTINES catalog table. The specific name can be used to uniquely identify the function in several SQL statements (such as ALTER FUNCTION, COMMENT, DROP, GRANT, and REVOKE) and must be used in Db2 commands (START FUNCTION, STOP FUNCTION, and DISPLAY FUNCTION). However, the function cannot be invoked by its specific name.

PARAMETER CCSID or VARCHAR

Specifies the encoding scheme for character and graphic string parameters, and in the case of LANGUAGE C, specifies that representation of variable length string parameters.

CCSID

Indicates whether the encoding scheme for character and graphic string parameters is ASCII, EBCDIC, or UNICODE. The default encoding scheme is the value specified in the CCSID clauses of the parameter list or RETURNS clause, or in the field DEF ENCODING SCHEME on installation panel DSNTIPF.

This clause provides a convenient way to specify the encoding scheme for *all* string parameters. If individual CCSID clauses are specified for individual parameters in addition to this PARAMETER CCSID clause, the value specified in *all* of the CCSID clauses must be the same value that is specified in this clause.

This clause also specifies the encoding scheme to be used for system-generated parameters of the routine such as message tokens and DBINFO.

VARCHAR

Specifies that the representation of the values of varying length character string-parameters, including, if applicable, the output of the function, for functions which specify LANGUAGE C.

This option can only be specified if LANGUAGE C is also specified.

NULTERM

Specifies that variable length character string parameters are represented in a NUL-terminated string form.

STRUCTURE

Specifies that variable length character string parameters are represented in a VARCHAR structure form.

Using the PARAMETER VARCHAR clause, there is no way to specify the VARCHAR form of an individual parameter as there is with the PARAMETER CCSID clause. The PARAMETER VARCHAR clause only applies to parameters in the parameter list of a function and in the RETURNS clause. It does not apply to system-generated parameters of the routine such as message tokens and DBINFO.

In a data sharing environment, you should not specify the PARAMETER VARCHAR clause until all members of the data sharing group support the clause. If some group members support this clause and others do not, and PARAMETER VARCHAR is specified in an external routine, the routine will encounter different parameter forms depending on which group member invokes the routine.

EXTERNAL

Specifies that the CREATE FUNCTION statement is being used to define a new function that is based on code that is written in an external programming language.

Db2 loads the load module when the function is invoked. The load module is created when the program that contains the function body is compiled and link-edited. The load module does not need to exist when the CREATE FUNCTION statement is executed. However, it must exist and be accessible by the current server when the function is invoked.

You can specify the EXTERNAL clause in one of the following ways:

```
EXTERNAL  
EXTERNAL NAME PKJVSP1  
EXTERNAL NAME 'PKJVSP1'
```

If you specify an external program name, you must use the NAME keyword. For example, this syntax is not valid:

```
EXTERNAL PKJVSP1
```

NAME *external-program-name* or *identifier*

Identifies the user-written code that implements the user-defined function.

If LANGUAGE is JAVA, *external-program-name* must be specified and enclosed in single quotation marks, with no extraneous blanks within the single quotation marks. It must specify a valid *external-java-routine-name*. If multiple *external-program-names* are specified, the total length of all of them must not be greater than 1305 bytes and they must be separated by a space or a line break. Do not specify a JAR file for a JAVA function for which NO SQL is also specified.

An *external-java-routine-name* contains the following parts:

jar-name

Identifies the name given to the JAR file when it was installed in the database. The name contains *jar-id*, which can optionally be qualified with a schema. Examples are "myJar" and "mySchema.myJar." The unqualified *jar-id* is implicitly qualified with a schema name according to the following rules:

- If the statement is embedded in a program, the schema name is the authorization ID in the QUALIFIER bind option when the package or plan was created or last rebound. If the QUALIFIER was not specified, the schema name is the owner of the package or plan.
- If the statement is dynamically prepared, the schema name is the SQL authorization ID in the CURRENT SCHEMA special register.

If *jar-name* is specified, it must exist when the CREATE FUNCTION statement is processed.

If *jar-name* is not specified, the function is loaded from the class file directly instead of being loaded from a JAR file. Db2 searches the directories in the CLASSPATH associated with the WLM Environment. Environmental variables for Java routines are specified in a data set identified in a JAVAENV DD card on the JCL used to start the address space for a WLM-managed function.

method-name

Identifies the name of the method and must not be longer than 254 bytes. Its package, class, and method ID's are specific to Java and as such are not limited to 18 bytes. In addition, the rules for what these can contain are not necessarily the same as the rules for an SQL ordinary identifier.

package-id

Identifies a package. The concatenated list of *package-ids* identifies the package that the class identifier is part of. If the class is part of a package, the method name must include the complete package prefix, such as "myPacks.UserFuncs." The Java virtual machine looks in the directory "/myPacks/UserFuncs/" for the classes.

class-id

Identifies the class identifier of the Java object.

method-id

Identifies the method identifier with the Java class to be invoked.

method-signature

Identifies a list of zero or more Java data types for the parameter list and must not be longer than 1024 bytes. Specify the *method-signature* if the user-defined function involves any input or output parameters that can be NULL. When the function being created is called, Db2 searches for a Java method with the exact *method-signature*. The number of *java-datatype* elements specified indicates how many parameters that the Java method must have.

A Java procedure can have no parameters. In this case, you code an empty set of parentheses for *method-signature*. If a Java *method-signature* is not specified, Db2 searches for a Java method with a signature derived from the default JDBC types associated with the SQL types specified in the parameter list of the CREATE FUNCTION statement.

For other values of LANGUAGE, the name can be a string constant that is no longer than 8 characters. It must conform to the naming conventions for load modules. Alphabetical extenders for national languages can be used as the first character and as subsequent characters in the load module name.

If you do not specify the NAME clause, 'NAME *function-name*' is implicit. In this case, *function-name* must not be longer than 8 characters.

LANGUAGE

Specifies the language interface convention to which the body of the function is written. All programs must be designed to run in IBM's Language Environment environment.

ASSEMBLE

The function is written in Assembler.

C

The function is written in C or C++.

COBOL

The function is written in COBOL, including the object-oriented language extensions.

JAVA

The user-defined function is written in Java and is executed in the Java Virtual Machine. When LANGUAGE JAVA is specified, the EXTERNAL NAME clause must also be specified with a valid *external-java-routine-name* and PARAMETER STYLE must be specified with JAVA.

Do not specify LANGUAGE JAVA when SCRATCHPAD, FINAL CALL, DBINFO, PROGRAM TYPE MAIN, or RUN OPTIONS is in effect.

PLI

The function is written in PL/I.

PARAMETER STYLE

Specifies the conventions for passing parameters to and returning a value from the function.

SQL

Specifies the parameter passing convention that supports passing null values both as input and for output. The parameters that are passed between the invoking SQL statement and the function include:

- *n* parameters for the input parameters that are specified for the function
- A parameter for the result of the function

- n parameters for the indicator variables for the input parameters
- A parameter for the indicator variable for the result
- The SQLSTATE to be returned to Db2
- The qualified name of the function
- The specific name of the function
- The SQL diagnostic string to be returned to Db2
- The function can also pass from zero to three additional parameters:
 - The scratchpad, if SCRATCHPAD is specified
 - The call type, if FINAL CALL is specified
 - The DBINFO structure, if DBINFO is specified

JAVA

Indicates that the user-defined function uses a convention for passing parameters that conforms to the Java and SQLJ specifications. PARAMETER STYLE JAVA can be specified only if LANGUAGE is specified as JAVA. JAVA must be specified for PARAMETER STYLE when LANGUAGE JAVA is specified.

NOT DETERMINISTIC or DETERMINISTIC

Specifies whether the function returns the same results each time that the function is invoked with the same input arguments.

NOT DETERMINISTIC

The function might not return the same result each time that the function is invoked with the same input arguments. The function depends on some state values that affect the results. Db2 uses this information to disable the merging of views and table expressions when processing SELECT or SQL data change statements that refer to this function. An example of a function that is not deterministic is one that generates random numbers, or any function that contains SQL statements.

NOT DETERMINISTIC is the default.

Some functions that are not deterministic can receive incorrect results if the function is executed by parallel tasks. Specify the DISALLOW PARALLEL clause for these functions.

DETERMINISTIC

The function always returns the same result each time that the function is invoked with the same input arguments. An example of a deterministic function is a function that calculates the square root of the input. Db2 uses this information to enable the merging of views and table expressions for SELECT or SQL data change statements that refer to this function. DETERMINISTIC is not the default. If applicable, specify DETERMINISTIC to prevent non-optimal access paths from being chosen for SQL statements that refer to this function.

Db2 does not verify that the function program is consistent with the specification of DETERMINISTIC or NOT DETERMINISTIC.

FENCED

Specifies that the external function runs in an external address space to prevent the function from corrupting Db2 storage.

FENCED is the default.

RETURNS NULL ON NULL INPUT or CALLED ON NULL INPUT

Specifies whether the function is called if any of the input arguments is null at execution time.

RETURNS NULL ON NULL INPUT

The function is not called if any of the input arguments is null. The result is the null value. RETURNS NULL ON INPUT is the default.

CALLED ON NULL INPUT

The function is called regardless of whether any of the input arguments are null, making the function responsible for testing for null argument values. The function can return a null or nonnull value.

MODIFIES SQL DATA, READS SQL DATA, CONTAINS SQL, or NO SQL

Specifies the classification of SQL statements and nested routines that this routine can execute or invoke. The database manager verifies that the SQL statements issued by the function, and all routines locally invoked by the routine, are consistent with this specification; the verification is not performed when nested remote routines are invoked. For the classification of each statement, see [Appendix D, “SQL statement data access classification for routines,”](#) on page 2275.

MODIFIES SQL DATA

Specifies that the function can execute any SQL statement except the statements that are not supported in functions. Do not specify MODIFIES SQL DATA when ALLOW PARALLEL is in effect.

If a function that is defined with MODIFIES SQL DATA is invoked anywhere except the *select-clause* of the outermost SELECT statement, the results are unpredictable because the function can be invoked multiple times depending on the access plan that is used.

Recommendation: If a SELECT statement invokes a function that is defined with the MODIFIES SQL DATA option, ensure that statements nested inside the function do not modify objects that are referenced in any SQL statement at a higher level of nesting. Otherwise, unpredictable results are likely to occur.

READS SQL DATA

Specifies that the function can execute statements with a data access indication of READS SQL DATA, CONTAINS SQL, or NO SQL. The function cannot execute SQL statements that modify data. The default is READS SQL DATA.

CONTAINS SQL

Specifies that the function can execute only SQL statements with an access indication of CONTAINS SQL or NO SQL. The function cannot execute statements that read or modify data.

NO SQL

Specifies that the function can execute only SQL statements with a data access classification of NO SQL. Do not specify NO SQL for a JAVA function that uses a JAR file.

EXTERNAL ACTION or NO EXTERNAL ACTION

Specifies whether the function takes an action that changes the state of an object that Db2 does not manage. An example of an external action is sending a message or writing a record to a file.

Because Db2 uses the RRS attachment for external functions, Db2 can participate in two-phase commit with any other resource manager that uses RRS. For resource managers that do not use RRS, there is no coordination of commit or rollback operations on non-Db2 resources.

EXTERNAL ACTION

Specifies that the function can take an action that changes the state of an object that Db2 does not manage.

Some SQL statements that invoke functions with external actions can result in incorrect results if parallel tasks execute the function. For example, if the function sends a note for each initial call to it, one note is sent for each parallel task instead of once for the function. Specify the DISALLOW PARALLEL clause for functions that do not work correctly with parallelism.

If you specify EXTERNAL ACTION, Db2:

- Materializes the views and table expressions in SELECT or data change statements statements that refer to the function. This materialization can adversely affect the access paths that are chosen for the SQL statements that refer to this function. Do not specify EXTERNAL ACTION if the function does not have an external action.
- Does not move the function from one task control block (TCB) to another between FETCH operations.

- Does not allow another function or stored procedure to use the TCB until the cursor is closed. This is also applicable for cursors declared WITH HOLD.

The only changes to resources made outside of Db2 that are under the control of commit and rollback operations are those changes made under RRS control.

EXTERNAL ACTION is the default.

NO EXTERNAL ACTION

Specifies that the function does not take any action that changes the state of an object that Db2 does not manage. Db2 uses this information to enable the merging of views and table expressions for SELECT and data change statements that refer to this function. If applicable, specify NO EXTERNAL ACTION to prevent non-optimal access paths from being chosen for SQL statements that refer to this function.

Although the scope of global variables are beyond the scope of the routine, global variables can be set in the routine body when NO EXTERNAL ACTION is specified.

Db2 does not verify that the function program is consistent with the specification of EXTERNAL ACTION or NO EXTERNAL ACTION.

NO PACKAGE PATH or PACKAGE PATH *package-path*

Specifies the package path to use when the function is run. This is the list of the possible package collections into which the DBRM this is associated with the function is bound.

NO PACKAGE PATH

Specifies that the list of package collections for the function is the same as the list of package collection IDs for the program that invokes the function. If the program that invokes the function does not use a package, Db2 resolves the package by using the CURRENT PACKAGE PATH special register, the CURRENT PACKAGESET special register, or the PKLIST bind option (in this order). For information about how Db2 uses these three items, see [Binding an application plan \(Db2 Application programming and SQL\)](#).

PACKAGE PATH *package-path*

Specifies a list of package collections, in the same format as the SET CURRENT PACKAGE PATH special register.

If the COLLID clause is specified with PACKAGE PATH, the COLLID clause is ignored when the function is invoked.

The *package-path* value that is provided when the function is created is checked when the function is invoked. If *package-path* contains SESSION_USER (or USER), PATH, or PACKAGE PATH, an error is returned when the *package-path* value is checked.

NO SCRATCHPAD or SCRATCHPAD

Specifies whether Db2 is to provide a scratchpad for the function. It is strongly recommended that external functions be reentrant, and a scratchpad provides an area for the function to save information from one invocation to the next.

NO SCRATCHPAD

Specifies that a scratchpad is not allocated and passed to the function. NO SCRATCHPAD is the default.

SCRATCHPAD *length*

Specifies that when the function is invoked for the first time, Db2 allocates memory for a scratchpad. A scratchpad has the following characteristics:

- *length* must be in the range 1–32767. The default value is 100 bytes.
- Db2 initializes the scratchpad to all binary zeros (X'00's).
- The scope of a scratchpad is the SQL statement. For each reference to the function in an SQL statement, there is one scratchpad. For example, assuming that function UDFX was defined with the SCRATCHPAD keyword, three scratchpads are allocated for the three references to UDFX in the following SQL statement:

```
SELECT A, UDFX(A) FROM TABLEB
WHERE UDFX(A) > 103 OR UDFX(A) < 19;
```

If the function is run under parallel tasks, one scratchpad is allocated for each parallel task of each reference to the function in the SQL statement. This can lead to unpredictable results. For example, if a function uses the scratchpad to count the number of times that it is invoked, the count reflects the number of invocations done by the parallel task and not the SQL statement. Specify the `DISALLOW PARALLEL` clause for functions that will not work correctly with parallelism.

- The scratchpad is persistent. Db2 preserves its content from one invocation of the function to the next. Any changes that the function makes to the scratchpad on one call are still there on the next call. Db2 initializes the scratchpads when it begins to execute an SQL statement. Db2 does not reset scratchpads when a correlated subquery begins to execute.
- The scratchpad can be a central point for the system resources that the function acquires. If the function acquires system resources, specify `FINAL CALL` to ensure that Db2 calls the function one more time so that the function can free those system resources.

Each time the function is invoked, Db2 passes an additional argument to the function that contains the address of the scratchpad.

If you specify `SCRATCHPAD`, Db2:

- Does not move the function from one task control block (TCB) to another between `FETCH` operations.
- Does not allow another function or stored procedure to use the TCB until the cursor is closed. This is also applicable for cursors declared `WITH HOLD`.

Do not specify `SCRATCHPAD` when `LANGUAGE JAVA` is in effect.

NO FINAL CALL or FINAL CALL

Specifies whether a *final call* is made to the function. A final call enables the function to free any system resources that it has acquired. A final call is useful when the function has been defined with the `SCRATCHPAD` keyword and the function acquires system resource and anchors them in the scratchpad.

NO FINAL CALL

Specifies that a final call is not made to the function. The function does not receive an additional argument that specifies the type of call. `NO FINAL CALL` is the default.

FINAL CALL

Specifies that a final call is made to the function. To differentiate between final calls and other calls, the function receives an additional argument that specifies the type of call. The types of calls are:

First call

Specifies that the first call to the function for this reference to the function in this SQL statement. A first call is a normal call—SQL arguments are passed and the function is expected to return a result.

Normal call

Specifies that SQL arguments are passed and the function is expected to return a result.

Final call

Specifies that the last call to the function to enable the function to free resources. A final call is not a normal call. If an error occurs, Db2 attempts to make the final call unless the function abended. A final call occurs at these times:

- *End of statement*: When the cursor is closed for cursor-oriented statements, or the execution of the statement has completed.
- *End of a parallel task*: When the function is executed by parallel tasks.
- *End of transaction*: When normal end of statement processing does not occur. For example, the logic of an application, for some reason, bypasses closing the cursor.

If a commit operation occurs while a cursor defined as WITH HOLD is open, a final call is made when the cursor is closed or the application ends. If a commit occurs at the end of a parallel task, a final call is made regardless of whether a cursor defined as WITH HOLD is open.

If a commit, rollback, or abort operation causes the final call, the function cannot issue any SQL statements when it is invoked.

Some functions that use a final call can receive incorrect results if parallel tasks execute the function. For example, if a function sends a note for each final call to it, one note is sent for each parallel task instead of once for the function. Specify the DISALLOW PARALLEL clause for functions that have inappropriate actions when executed in parallel.

Do not specify FINAL CALL when LANGUAGE JAVA is in effect.

ALLOW or DISALLOW PARALLEL

For a single reference to the function, specifies whether parallelism can be used when the function is invoked. Although parallelism can be used for most scalar functions, some functions such as those that depend on a single copy of the scratchpad cannot be invoked with parallel tasks.

Consider these characteristics when determining which clause to use:

- If all invocations of the function are completely independent from one another, specify ALLOW PARALLEL.
- If each invocation of the function updates the scratchpad, providing values that are of interest to the next invocation, such as incrementing a counter, specify DISALLOW PARALLEL.
- If the scratchpad is used only so that some expensive initialization processing is performed a minimal number of times, specify ALLOW PARALLEL.
- If the function performs some external action that should apply to only one partition, specify DISALLOW PARALLEL.
- If the function is defined with MODIFIES SQL DATA, specify DISALLOW PARALLEL, not ALLOW PARALLEL.

ALLOW PARALLEL is the default unless NOT DETERMINISTIC, EXTERNAL ACTION, SCRATCHPAD, or FINAL CALL is specified, in which case, DISALLOW PARALLEL is the default.

ALLOW PARALLEL

Specifies that Db2 can consider parallelism for the function. Parallelism is not forced on the SQL statement that invokes the function or on any SQL statement in the function. Existing restrictions on parallelism apply.

DISALLOW PARALLEL

Specifies that Db2 does not consider parallelism for the function.

NO DBINFO or DBINFO

Specifies whether additional status information is passed to the function when it is invoked.

NO DBINFO

No additional information is passed. NO DBINFO is the default.

DBINFO

An additional argument is passed when the function is invoked. The argument is a structure that contains information such as the application runtime authorization ID, the schema name, the name of a table or column that the function might be inserting into or updating, and identification of the database server that invoked the function. For details about the argument and its structure, see [DBINFO structure \(Db2 Application programming and SQL\)](#).

Do not specify DBINFO when LANGUAGE JAVA is in effect.

NO COLLID or COLLID *collection-id*

Identifies the package collection that is to be used when the function is executed. This is the package collection into which the DBRM that is associated with the function program is bound.

NO COLLID

The package collection for the function is the same as the package collection of the program that invokes the function. If a trigger invokes the function, the collection of the trigger package is used. If the invoking program does not use a package, Db2 resolves the package by using the CURRENT PACKAGE PATH special register, the CURRENT PACKAGESET special register, or the PKLIST bind option (in this order). For details about how Db2 uses these three items, see the information on package resolution in [Overriding the values that Db2 uses to resolve package lists \(Db2 Application programming and SQL\)](#).

NO COLLID is the default.

COLLID *collection-id*

The name of the package collection that is to be used when the function is executed.

WLM ENVIRONMENT

Identifies the WLM (workload manager) application environment in which the function is to run. The *name* of the WLM environment is an SQL identifier.

If you do not specify WLM ENVIRONMENT, the function runs in the WLM-established stored procedure address space that is specified at installation time. When LANGUAGE is JAVA, you must specify WLM ENVIRONMENT, and the WLM environment in which the function is to run must be Java-enabled.

name

The WLM environment in which the function must run. If another user-defined function or a stored procedure calls the function and that calling routine is running in an address space that is not associated with the WLM environment, Db2 routes the function request to a different address space.

(name,*)

When an SQL application program directly invokes the function, the WLM environment in which the function runs.

If another user-defined function or a stored procedure calls the function, the function runs in same environment that the calling routine uses. In this case, authorization to run the function in the WLM environment is not checked because the authorization of the calling routine suffices.

Users must have the appropriate authorization to execute functions in the specified WLM environment.

ASUTIME

Specifies the total amount of processor time, in CPU service units, that a single invocation of the function can run. The value is unrelated to the ASUTIME column of the resource limit specification table. This option is ignored if LANGUAGE JAVA is specified.

When you are debugging a function, setting a limit can be helpful if the function gets caught in a loop. For information on service units, see [z/OS MVS Initialization and Tuning Guide](#).

NO LIMIT

There is no limit on the service units. NO LIMIT is the default.

LIMIT *integer*

The limit on the number of CPU service units is a positive *integer* in the range 1–2147483647.

If the procedure uses more service units than the specified value, Db2 cancels the procedure.

The CPU cycles that are consumed by parallel tasks in a procedure do not contribute towards the specified ASUTIME LIMIT.

STAY RESIDENT

Specifies whether the load module for the function is to remain resident in memory when the function ends. This option is ignored if LANGUAGE JAVA is specified.

NO

The load module is deleted from memory after the function ends. Use NO for non-reentrant functions. NO is the default.

YES

The load module remains resident in memory after the function ends. Use YES for reentrant functions.

PROGRAM TYPE

Specifies whether the function program runs as a main routine or a subroutine.

SUB

The function runs as a subroutine. With LANGUAGE JAVA, PROGRAM TYPE SUB is the only valid option. SUB is the default.

MAIN

The function runs as a main routine.

SECURITY

Specifies how the function interacts with an external security product, such as RACF, to control access to non-SQL resources.

Db2

The function does not require an external security environment. If the function accesses resources that an external security product protects, the access is performed using the authorization ID that is associated with the WLM-established stored procedure address space.

Db2 is the default.

USER

An external security environment should be established for the function. If the function accesses resources that the external security product protects, the access is performed using the primary authorization ID of the process that invoked the function.

DEFINER

An external security environment should be established for the function. If the function accesses resources that the external security product protects, the access is performed using the authorization ID of the owner of the function.

STOP AFTER SYSTEM DEFAULT FAILURES, STOP AFTER *nn* FAILURES, or CONTINUE AFTER FAILURE

Specifies whether the routine is to be put in a stopped state after some number of failures.

STOP AFTER SYSTEM DEFAULT FAILURES

Specifies that this routine should be placed in a stopped state after the number of failures indicated by the value of field MAX ABEND COUNT on installation panel DSNTIPX. This is the default.

STOP AFTER *nn* FAILURES

Specifies that this routine should be placed in a stopped state after *nn* failures. The value *nn* can be an integer 1–32767.

CONTINUE AFTER FAILURE

Specifies that this routine should not be placed in a stopped state after any failure.

RUN OPTIONS *runtime-options*

Specifies the Language Environment runtime options to be used for the function. You must specify *runtime-options* as a character string that is no longer than 254 bytes. If you do not specify RUN OPTIONS or pass an empty string, Db2 does not pass any runtime options to Language Environment, and Language Environment uses its installation defaults. For a description of the Language Environment runtime options, see [Language Environment Programming Reference \(z/OS Language Environment Programming Reference\)](#).

Do not specify RUN OPTIONS when LANGUAGE JAVA is in effect.

INHERIT SPECIAL REGISTERS or DEFAULT SPECIAL REGISTERS

Specifies how special registers are set on entry to the routine.

INHERIT SPECIAL REGISTERS

Specifies that the values of special registers are inherited according to the rules listed in the table for characteristics of special registers in a user-defined function in [“Special registers in a user-defined function or a stored procedure” on page 215](#).

DEFAULT SPECIAL REGISTERS

Specifies that special registers are initialized to the default values, as indicated by the rules in the table for characteristics of special registers in a user-defined function in [“Special registers in a user-defined function or a stored procedure”](#) on page 215.

STATIC DISPATCH

At function resolution time, Db2 chooses a function based on the static (or declared) types of the function parameters. STATIC DISPATCH is the default.

NOT SECURED or SECURED

Specifies if the function is considered secure for row access control and column access control.

NOT SECURED

Specifies that the function is not considered as secure for row access control and column access control.

NOT SECURED is the default.

When the function is invoked, the arguments of the function must not reference a column for which a column mask is enabled when the table is using active column access control.

SECURED

Specifies that the function is considered secure for row access control and column access control.

The function must be defined with SECURED when it is referenced in a row permission or a column mask.

Notes for CREATE FUNCTION (external scalar)

Considerations for all types of user-defined functions:

For considerations that apply to all types of user-defined functions, see [“CREATE FUNCTION statement \(overview\)”](#) on page 1424.

Character string representation considerations:

The PARAMETER VARCHAR clause is specific to LANGUAGE C functions because of the native use of NUL-terminated strings in C. VARCHAR structure representation is useful when character string data is known to contain embedded NUL-terminators. It is also useful when it cannot be guaranteed that character string data does not contain embedded NUL-terminators.

PARAMETER VARCHAR does not apply to fixed length character strings, VARCHAR FOR BIT DATA, CLOB, DBCLOB, or implicitly generated parameters. The clause does not apply to VARCHAR FOR BIT DATA because BIT DATA can contain X'00' characters, and its value representation starts with length information. It does not apply to LOB data because a LOB value representation starts with length information.

PARAMETER VARCHAR does not apply to optional parameters that are implicitly provided to an external function. For example, a CREATE FUNCTION statement for LANGUAGE C must also specify PARAMETER STYLE SQL, which returns an SQLSTATE NULL-terminated character string; that SQLSTATE will not be represented in VARCHAR structured form. Likewise, none of the parameters that represent the qualified name of the function, the specific name of the function, or the SQL diagnostic string that is returned to the database manager will be represented in VARCHAR structured form.

Running external functions in WLM environments:

You can use the WLM ENVIRONMENT clause to identify the address space in which a function or is to run. Using different WLM environments lets you isolate one group of programs from another. For example, you might choose to isolate programs based on security requirements and place all payroll applications in one WLM environment because those applications deal with data, such as employee salaries.

To prevent a user from defining functions in sensitive WLM environments, Db2 invokes the external security manager to determine whether the user has authorization to issue CREATE FUNCTION statements that refer to the specified WLM environment. The following example shows the RACF

command that authorizes Db2 user DB2USER1 to register a function on Db2 subsystem DB2A that runs in the WLM environment named PAYROLL.

```
PERMIT DB2A.WLMENV.PAYROLL CLASS(DSNR) ID(DB2USER1) ACCESS(READ)
```

For more information, see [Managing authorizations for creation of stored procedures in WLM environments \(Managing Security\)](#).

Considerations for accessing message tokens and DBINFO:

Db2 returns system-generated parameters from a routine, such as message tokens and DBINFO. The message tokens and DBINFO are character string data. The CCSID for system-generated string parameters is determined from the CCSID that is in effect for string parameters that are defined for the routine. If the parameter list for the routine does not include any character or graphic string parameters, the CCSID for system-generated string parameters is determined from the PARAMETER CCSID option that is in effect for the routine. For example, with a Unicode database, you can specify PARAMETER CCSID EBCDIC to have the system-generated string parameters returned to the invoking application in EBCDIC.

Alternative syntax and synonyms:

To provide compatibility with previously releases of Db2 or other products in the Db2 family, Db2 supports the following alternative syntax:

- VARIANT as a synonym for NOT DETERMINISTIC
- NOT VARIANT as a synonym for DETERMINISTIC
- NOT NULL CALL as a synonym for RETURNS NULL ON NULL INPUT
- NULL CALL as a synonym for CALLED ON NULL INPUT
- PARAMETER STYLE DB2SQL as a synonym for PARAMETER STYLE SQL
- TIMEZONE can be specified as an alternative to TIME ZONE.

Examples for CREATE FUNCTION (external scalar)

Example 1

Assume that you want to write an external function program in C that implements the following logic:

```
output = 2 * input - 4
```

The function should return a null value if and only if one of the input arguments is null. The simplest way to avoid a function call and get a null result when an input value is null is to specify RETURNS NULL ON NULL INPUT on the CREATE FUNCTION statement or allow it to be the default. Write the statement needed to register the function, using the specific name MINENULL1.

```
CREATE FUNCTION NTEST1 (SMALLINT)
  RETURNS SMALLINT
  EXTERNAL NAME 'NTESTMOD'
  SPECIFIC MINENULL1
  LANGUAGE C
  DETERMINISTIC
  NO SQL
  FENCED
  PARAMETER STYLE SQL
  RETURNS NULL ON NULL INPUT
  NO EXTERNAL ACTION;
```

Example 2

Assume that user Smith wants to register an external function named CENTER in schema SMITH. The function program will be written in C and will be reentrant. Write the statement that Smith needs to register the function, letting Db2 generate a specific name for the function.

```
CREATE FUNCTION CENTER (INTEGER, FLOAT)
  RETURNS FLOAT
  EXTERNAL NAME 'MIDDLE'
  LANGUAGE C
```

```
DETERMINISTIC
NO SQL
FENCED
PARAMETER STYLE SQL
NO EXTERNAL ACTION
STAY RESIDENT YES;
```

Example 3

Assume that user McBride (who has administrative authority) wants to register an external function named CENTER in the SMITH schema. McBride plans to give the function specific name FOCUS98. The function program uses a scratchpad to perform some one-time only initialization and save the results. The function program returns a value with a FLOAT data type. Write the statement McBride needs to register the function and ensure that when the function is invoked, it returns a value with a data type of DECIMAL(8,4).

```
CREATE FUNCTION SMITH.CENTER (FLOAT, FLOAT, FLOAT)
  RETURNS DECIMAL(8,4) CAST FROM FLOAT
  EXTERNAL NAME 'CMOD'
  SPECIFIC FOCUS98
  LANGUAGE C
  DETERMINISTIC
  NO SQL
  FENCED
  PARAMETER STYLE SQL
  NO EXTERNAL ACTION
  SCRATCHPAD
  NO FINAL CALL;
```

Example 4

The following example registers a Java user-defined function that returns the position of the first vowel in a string. The user-defined function is written in Java, is to be run fenced, and is the FINDVWL method of class JAVAUDFS.

```
CREATE FUNCTION FINDV (CLOB(100K))
  RETURNS INTEGER
  FENCED
  LANGUAGE JAVA
  PARAMETER STYLE JAVA
  EXTERNAL NAME 'JAVAUDFS.FINDVWL'
  NO EXTERNAL ACTION
  CALLED ON NULL INPUT
  DETERMINISTIC
  NO SQL;
```

Related concepts

[External functions \(Db2 Application programming and SQL\)](#)

[Naming conventions](#)

The rules for forming a name depend on the type of the object designated by the name.

Related tasks

[Creating a user-defined function \(Db2 Application programming and SQL\)](#)

[Writing an external user-defined function \(Db2 Application programming and SQL\)](#)

CREATE FUNCTION statement (external table function)

This CREATE FUNCTION statement registers a user-defined external table function with a database server. A user-defined external table function can be used in the FROM clause of a subselect. It returns a table to the subselect by returning one row at a time each time it is invoked.

Invocation for CREATE FUNCTION (external table)

This statement can be embedded in an application program or issued interactively. It is an executable statement that can be dynamically prepared only if DYNAMICRULES RUN behavior is in effect. For more information, see [“Authorization IDs and dynamic SQL”](#) on page 94.

Authorization for CREATE FUNCTION (external table)

The privilege set defined below must include at least one of the following:

- The CREATEIN privilege on the schema
- SYSADM or SYSCTRL authority
- System DBADM
- Installation SYSOPR authority (when the current SQLID of the process is set to SYSINSTL)

The authorization ID that matches the schema name implicitly has the CREATEIN privilege on the schema.

If the authorization ID that is used to create the function has the installation SYSADM authority or the installation SYSOPR authority and if the current SQLID is set to SYSINSTL, the function is identified as system-defined function.

Additional privileges are required if the function uses a table as a parameter, refers to a distinct type, or is to run in a WLM (workload manager) environment. These privileges are:

- The SELECT privilege on any table that is an input parameter to the function.
- The USAGE privilege on each distinct type that the function references.
- Authority to create programs in the specified WLM environment. This authorization is obtained from an external security product, such as RACF.

At least one of the following additional privileges is required if the SECURED option is specified

- SECADM authority
- CREATE_SECURE_OBJECT privilege

Privilege set: If the statement is embedded in an application program, the privilege set is the privileges that are held by the owner of the plan or package. If the owner is a role, the implicit schema match does not apply and this role needs to include one of the previously listed conditions.

If the statement is dynamically prepared and is not running in a trusted context for which the ROLE AS OBJECT OWNER clause is specified, the privilege set is the set of privileges that are held by the SQL authorization ID of the process. If the schema name is not the same as the SQL authorization ID of the process, one of the following conditions must be met:

- The privilege set includes SYSADM or SYSCTRL authority.
- The SQL authorization ID of the process has the CREATEIN privilege on the schema.

Syntax for CREATE FUNCTION (external table)

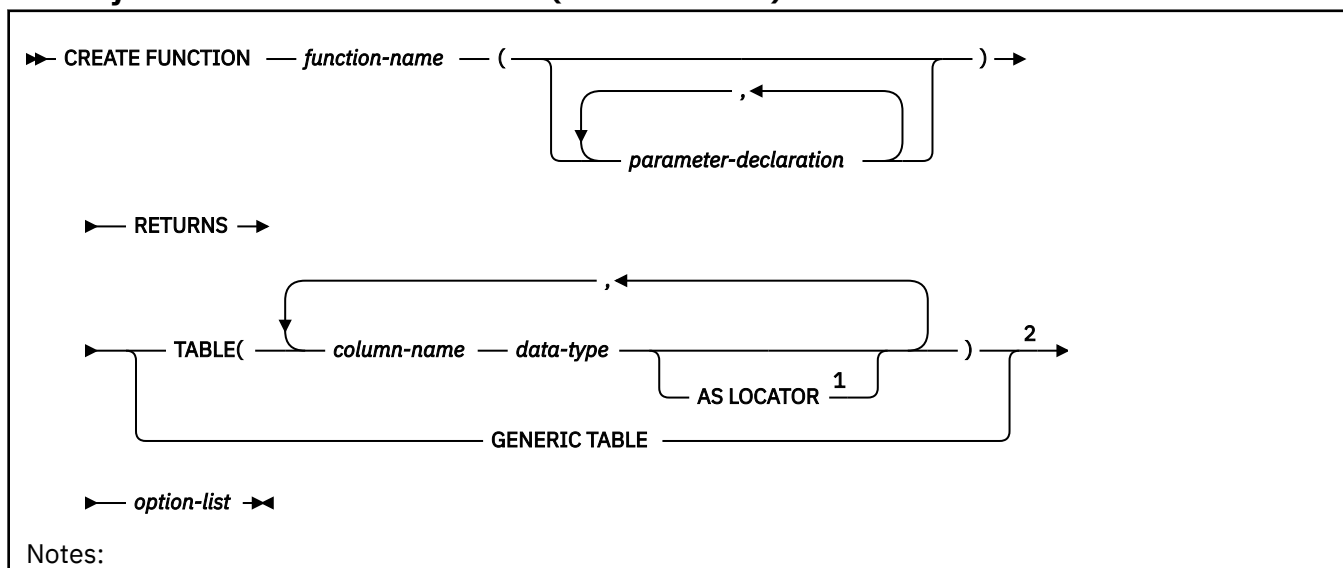

- ¹ AS LOCATOR can be specified only for a LOB data type or a distinct type based on a LOB data type.
- ² This clause and the clauses that follow in the *option-list* can be specified in any order.

parameter-declaration:

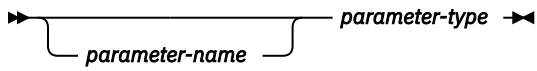

parameter-type:

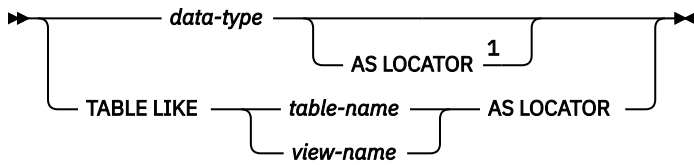

Notes:

- ¹ AS LOCATOR can be specified only for a LOB data type or a distinct type based on a LOB data type.

data-type:

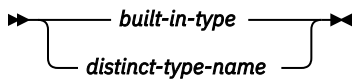

built-in-type:

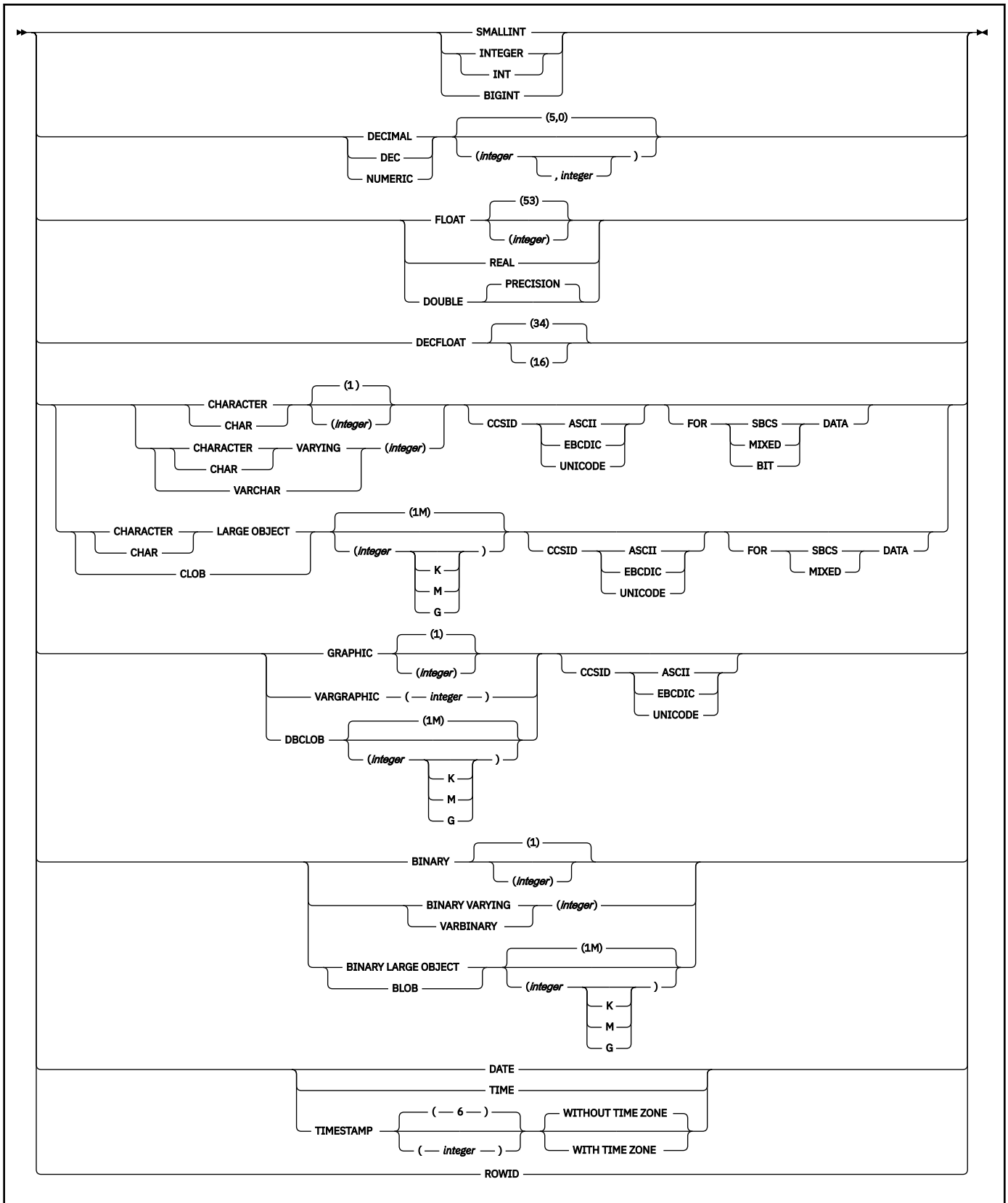

option-list: (The clauses in the *option-list* can be specified in any order.)

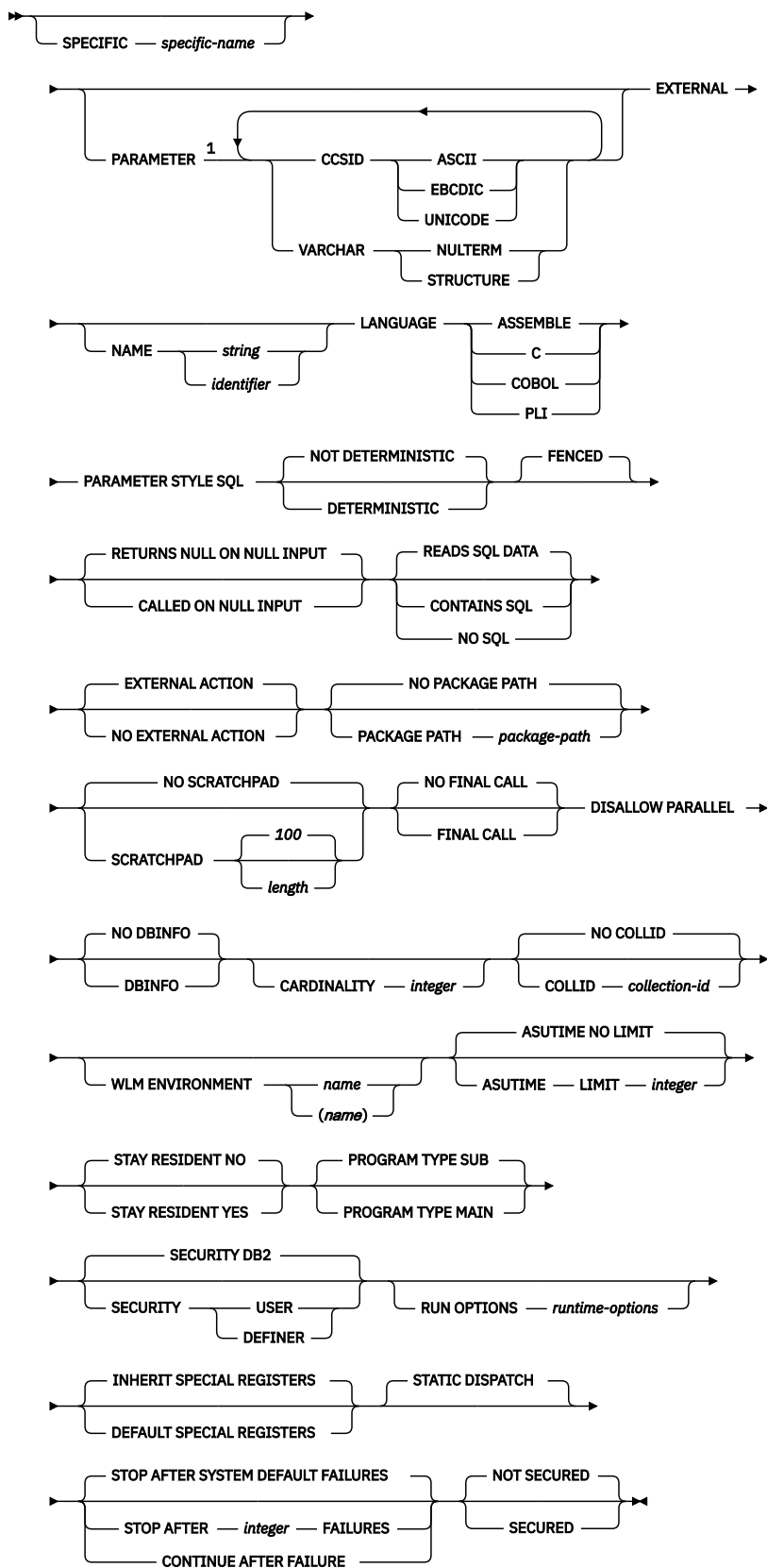

Notes:

¹ The same clause must not be specified more than one time.

Description for CREATE FUNCTION (external table)

function-name

Names the user-defined function. The name is implicitly or explicitly qualified by a schema name. For more information, see "Choosing the schema and function names" and "Determining the uniqueness of functions in a schema" in ["CREATE FUNCTION statement \(overview\)"](#) on page 1424.

(parameter-declaration,...)

Identifies the number of input parameters of the function, and specifies the data type of each parameter. All of the parameters for a function are input parameters and are nullable. There must be one entry in the list for each parameter that the function expects to receive. Although not required, you can give each parameter a name.

A function can have no parameters. In this case, you must code an empty set of parentheses, for example:

```
CREATE FUNCTION WOOFER()
```

parameter-name

Specifies the name of the input parameter. The name is an SQL identifier, and each name in the parameter list must not be the same as any other name. The same name cannot be used for a parameter name and a column name.

data-type

Specifies the data type of the input parameter. The data type can be a built-in data type or a user-defined type.

built-in-type

The data type of the input parameter is a built-in data type.

For information on the data types, see [built-in-type](#).

For parameters with a character or graphic data type, the PARAMETER CCSID clause or CCSID clause indicates the encoding scheme of the parameter. If you do not specify either of these clauses, the encoding scheme is the value of field DEF ENCODING SCHEME on installation panel DSNTIPF.

distinct-type-name

The data type of the input parameter is a distinct type. Any length, precision, scale, subtype, or encoding scheme attributes for the parameter are those of the source type of the distinct type.

If you specify the name of the distinct type without a schema name, Db2 resolves the schema name by searching the schemas in the SQL path.

Although parameters with a character data type have an implicitly or explicitly specified subtype (BIT, SBCS, or MIXED), the function program can receive character data of any subtype. Therefore, conversion of the input data to the subtype of the parameter might occur when the function is invoked. An error occurs if mixed data that actually contains DBCS characters is used as the value for an input parameter that is declared with an SBCS subtype.

Parameters with a datetime data type or a distinct type are passed to the function as a different data type:

- A datetime type parameter is passed as a character data type, and the data is passed in ISO format.

The encoding scheme for a datetime type parameter is the same as the implicitly or explicitly specified encoding scheme of any character or graphic string parameters. If no character or graphic string parameters are passed, the encoding scheme is the value of field DEF ENCODING SCHEME on installation panel DSNTIPF.

- A distinct type parameter is passed as the source type of the distinct type.

AS LOCATOR

Specifies that a locator to the value of the parameter is passed to the function instead of the actual value. Specify AS LOCATOR only for parameters with a LOB data type or a distinct type

that is based on a LOB data type. Passing locators instead of values can result in fewer bytes being passed to the function, especially when the value of the parameter is very large.

The AS LOCATOR clause has no effect on determining whether data types can be promoted, nor does it affect the function signature, which is used in function resolution.

TABLE LIKE *table-name* or *view-name* AS LOCATOR

Specifies that the parameter is a transition table. However, when the function is invoked, the actual values in the transition table are not passed to the function. A single value is passed instead. This single value is a locator to the table, which the function uses to access the columns of the transition table. A function with a table parameter can only be invoked from the triggered action of a trigger.

The use of TABLE LIKE provides an implicit definition of the transition table. It specifies that the transition table has the same number of columns as the identified table or view. If a table is specified, the transition table includes columns that are defined as implicitly hidden in the table. The columns have the same data type, length, precision, scale, subtype, and encoding scheme as the identified table or view, as they are described in catalog tables SYSCOLUMNS and SYSTABLESPACE. The number of columns and the attributes of those columns are determined at the time the CREATE FUNCTION statement is processed. Any subsequent changes to the number of columns in the table or the attributes of those columns do not affect the parameters of the function.

table-name or *view-name* must identify a table or view that exists at the current server. A view cannot have columns of length 0. The name must not identify a declared temporary table. The table that is identified can contain XML columns; however, the function cannot reference those XML columns. The name does not have to be the same name as the table that is associated with the transition table for the trigger. An unqualified table or view name is implicitly qualified according to the following rules:

- If the CREATE FUNCTION statement is embedded in a program, the implicit qualifier is the authorization ID in the QUALIFIER bind option when the plan or package was created or last rebound. If QUALIFIER was not used, the implicit qualifier is the owner of the plan or package.
- If the CREATE FUNCTION statement is dynamically prepared, the implicit qualifier is the SQL authorization ID in the CURRENT SCHEMA special register.

When the function is invoked, the corresponding columns of the transition table identified by the table locator and the table or view identified in the TABLE LIKE clause must have the same definition. The data type, length, precision, scale, and encoding scheme of these columns must match exactly. The description of the table or view at the time the CREATE FUNCTION statement was executed is used.

Additionally, a character FOR BIT DATA column of the transition table cannot be passed as input for a table parameter for which the corresponding column of the table specified at the definition is not defined as character FOR BIT DATA. (The definition occurs with the CREATE FUNCTION statement.) Likewise, a character column of the transition table that is not FOR BIT DATA cannot be passed as input for a table parameter for which the corresponding column of the table specified at the definition is defined as character FOR BIT DATA.

For more information about using table locators, see [Accessing transition tables in a user-defined function or stored procedure \(Db2 Application programming and SQL\)](#).

RETURNS TABLE(*column-name data-type* ...)

Identifies that the output of the function is a table. The parentheses that follow the keyword enclose the list of names and data types of the columns of the table.

column-name

Specifies the name of the column. The name is an SQL identifier and must be unique within the RETURNS TABLE clause for the function.

data-type

Specifies the data type of the column. The column is nullable.

AS LOCATOR

Specifies that the function returns a locator to the value rather than the actual value. You can specify AS LOCATOR only for a LOB data type or a distinct type based on a LOB data type.

RETURNS GENERIC TABLE

Specifies that the output of the function is a generic table. This option can only be specified if LANGUAGE C is also specified.

The names and data types of the columns must be declared when the table function is referenced using the *typed-correlation-clause* of the subselect.

For more information, see [“typed-correlation-clause” on page 1029](#).

SPECIFIC *specific-name*

Specifies a unique name for the function. The name is implicitly or explicitly qualified with a schema name. The name, including the schema name, must not identify the specific name of another function that exists at the current server.

The unqualified form of *specific-name* is an SQL identifier. The qualified form is an SQL identifier (the schema name) followed by a period and an SQL identifier.

If you do not specify a schema name, it is the same as the explicit or implicit schema name of the function name (*function-name*). If you specify a schema name, it must be the same as the explicit or implicit schema name of the function name.

If you do not specify the SPECIFIC clause, the default specific name is the name of the function. However, if the function name does not provide a unique specific name or if the function name is a single asterisk, Db2 generates a specific name in the form of:

```
SQLxxxxxxxxxxxxx
```

where 'xxxxxxxxxxxxx' is a string of 12 characters that make the name unique.

The specific name is stored in the SPECIFIC column of the SYSROUTINES catalog table. The specific name can be used to uniquely identify the function in several SQL statements (such as ALTER FUNCTION, COMMENT, DROP, GRANT, and REVOKE) and in Db2 commands (START FUNCTION, STOP FUNCTION, and DISPLAY FUNCTION). However, the function cannot be invoked by its specific name.

PARAMETER CCSID or VARCHAR

CCSID

Indicates whether the encoding scheme for character or graphic string parameters is ASCII, EBCDIC, or UNICODE. The default encoding scheme is the value specified in the CCSID clauses of the parameter list or RETURNS TABLE clause, or in the field DEF ENCODING SCHEME on installation panel DSNTIPF.

This clause provides a convenient way to specify the encoding scheme for character or graphic string parameters. If individual CCSID clauses are specified for individual parameters in addition to this PARAMETER CCSID clause, the value specified in *all* of the CCSID clauses must be the same value that is specified in this clause.

This clause also specifies the encoding scheme to be used for system-generated parameters of the routine such as message tokens and DBINFO.

VARCHAR

Specifies that the representation of the values of varying length character string-parameters, including, if applicable, the output of the function, for functions which specify LANGUAGE C.

This option can only be specified if LANGUAGE C is also specified.

NULTERM

Specifies that variable length character string parameters are represented in a NUL-terminated string form.

STRUCTURE

Specifies that variable length character string parameters are represented in a VARCHAR structure form.

Using the PARAMETER VARCHAR clause, there is no way to specify the VARCHAR form of an individual parameter as there is with PARAMETER CCSID. The PARAMETER VARCHAR clause only applies to parameters in the parameter list of a function and in the RETURNS TABLE clause. It does not apply to system-generated parameters of the routine such as message tokens and DBINFO.

In a data sharing environment, you should not specify the PARAMETER VARCHAR clause until all members of the data sharing group support the clause. If some group members support this clause and others do not, and PARAMETER VARCHAR is specified in an external routine, the routine will encounter different parameter forms depending on which group member invokes the routine.

EXTERNAL

Specifies that the function being registered is based on code that is written in an external programming language and adheres to the documented linkage conventions and interface of that language.

If you do not specify the NAME clause, 'NAME *function-name*' is implicit. In this case, *function-name* must not be longer than 8 characters.

NAME string or identifier

Identifies the name of the load module that contains the user-written code that implements the logic of the function.

For other values of LANGUAGE, the name can be a string constant that is no longer than 8 characters. It must conform to the naming conventions for load modules. Alphabetical extenders for national languages can be used as the first character and as subsequent characters in the load module name.

Db2 loads the load module when the function is invoked. The load module is created when the program that contains the function body is compiled and link-edited. The load module does not need to exist when the CREATE FUNCTION statement is executed. However, it must exist and be accessible by the current server when the function is invoked.

You can specify the EXTERNAL clause in one of the following ways:

```
EXTERNAL  
EXTERNAL NAME PKJVSP1  
EXTERNAL NAME 'PKJVSP1'
```

If you specify an external program name, you must use the NAME keyword. For example, this syntax is not valid:

```
EXTERNAL PKJVSP1
```

LANGUAGE

Specifies the application programming language in which the function program is written. All programs must be designed to run in IBM's Language Environment environment.

ASSEMBLE

The function is written in Assembler.

C

The function is written in C or C++. The VARCHAR clause can only be specified if LANGUAGE C is specified.

COBOL

The function is written in COBOL, including the object-oriented language extensions.

PLI

The function is written in PL/I.

PARAMETER STYLE SQL

Specifies the linkage convention that the function program uses to receive input parameters from and pass return values to the invoking SQL statement.

PARAMETER STYLE SQL specifies the parameter passing convention that supports passing null values both as input and for output.

If the RETURNS TABLE clause is specified, the parameters that are passed between the invoking SQL statement and the function include:

- n parameters for the input parameters that are specified for the function
- m parameters for the result columns of the function that are specified on the RETURNS TABLE clause
- n parameters for the indicator variables for the input parameters
- m parameters for the indicator variables of the result columns of the function that are specified on the RETURNS TABLE clause
- The SQLSTATE to be returned to Db2
- The qualified name of the function
- The specific name of the function
- The SQL diagnostic string to be returned to Db2
- The scratchpad, if SCRATCHPAD is specified
- The call type
- The DBINFO structure, if DBINFO is specified

If the RETURNS GENERIC TABLE clause is specified, the parameters that are passed between the invoking SQL statement and the function include:

- n parameters for the input parameters that are specified for the function
- n parameters for the indicator variables for the input parameters
- m parameters for the result columns of the function that are specified on the RETURNS GENERIC TABLE clause
- A result table descriptor that contains the following:
 - m result columns of the function that are specified in the *typed-correlation-clause* of the *table-function-reference* in a SELECT statement
 - An array of m , 4-byte addresses to the values of the result columns
 - An array of m , null indicators of the result columns
- The SQLSTATE to be returned to Db2
- The qualified name of the function
- The specific name of the function
- The SQL diagnostic string to be returned to Db2
- The scratchpad, if SCRATCHPAD is specified
- The call type
- The DBINFO structure, if DBINFO is specified

For complete details about the structure of the parameter list that is passed, see [DBINFO structure \(Db2 Application programming and SQL\)](#).

NOT DETERMINISTIC or DETERMINISTIC

Specifies whether the function returns the same results each time that the function is invoked with the same input arguments.

NOT DETERMINISTIC

The function might not return the same results each time that the function is invoked with the same input arguments. The function depends on some state values that affect the results. Db2

uses this information to disable the merging of views and table expressions when processing SELECT and SQL data change statements that refer to this function. An example of a function that is not deterministic is one that generates random numbers, or any function that contains SQL statements.

NOT DETERMINISTIC is the default.

DETERMINISTIC

The function always returns the same result each time that the function is invoked with the same input arguments. An example of a deterministic function is a function that calculates the square root of the input. Db2 uses this information to enable the merging of views and table expressions for SELECT and SQL data change statements that refer to this function. DETERMINISTIC is not the default. If applicable, specify DETERMINISTIC to prevent non-optimal access paths from being chosen for SQL statements that refer to this function.

Db2 does not verify that the function program is consistent with the specification of DETERMINISTIC or NOT DETERMINISTIC.

FENCED

Specifies that the function runs in an external address space to prevent the function from corrupting Db2 storage.

FENCED is the default.

RETURNS NULL ON NULL INPUT or CALLED ON NULL INPUT

Specifies whether the function is called if any of the input arguments is null at execution time.

RETURNS NULL ON NULL INPUT

The function is not called if any of the input arguments is null. The result is an empty table, which is a table with no rows. RETURNS NULL ON INPUT is the default.

CALLED ON NULL INPUT

The function is called regardless of whether any of the input arguments are null, making the function responsible for testing for null argument values. The function can return an empty table, depending on its logic.

READS SQL DATA, CONTAINS SQL, or NO SQL

Specifies the classification of SQL statements and nested routines that this routine can execute or invoke. The database manager verifies that the SQL statements issued by the function, and all routines locally invoked by the routine, are consistent with this specification; the verification is not performed when nested remote routines are invoked. For the classification of each statement, see [Appendix D, "SQL statement data access classification for routines," on page 2275](#).

READS SQL DATA

Specifies that the function can execute statements with a data access indication of READS SQL DATA, CONTAINS SQL, or NO SQL. The function cannot execute SQL statements that modify data.

CONTAINS SQL

Specifies that the function can execute only SQL statements with an access indication of CONTAINS SQL or NO SQL. The function cannot execute statements that read or modify data.

NO SQL

Specifies that the function can execute only SQL statements with a data access classification of NO SQL.

EXTERNAL ACTION or NO EXTERNAL ACTION

Specifies whether the function takes an action that changes the state of an object that Db2 does not manage. An example of an external action is sending a message or writing a record to a file.

Because Db2 uses the RRS attachment for functions, Db2 can participate in two-phase commit with any other resource manager that uses RRS. For resource managers that do not use RRS, there is no coordination of commit or rollback operations on non-Db2 resources.

EXTERNAL ACTION

The function can take an action that changes the state of an object that Db2 does not manage.

If you specify EXTERNAL ACTION, Db2:

- Materializes the views and table expressions in SELECT and SQL data change statements that refer to the function. This materialization can adversely affect the access paths that are chosen for the SQL statements that refer to this function. Do not specify EXTERNAL ACTION if the function does not have an external action.
- Does not move the function from one task control block (TCB) to another between FETCH operations.
- Does not allow another function or stored procedure to use the TCB until the cursor is closed. This is also applicable for cursors declared WITH HOLD.

The only changes to resources made outside of Db2 that are under the control of commit and rollback operations are those changes made under RRS control.

EXTERNAL ACTION is the default.

NO EXTERNAL ACTION

The function does not take any action that changes the state of an object that Db2 does not manage. Db2 uses this information to enable the merging of views and table expressions for SELECT and SQL data change statements that refer to this function. If applicable, specify NO EXTERNAL ACTION to prevent non-optimal access paths from being chosen for SQL statements that refer to this function.

Although the scope of global variables are beyond the scope of the routine, global variables can be set in the routine body when NO EXTERNAL ACTION is specified.

NO PACKAGE PATH or PACKAGE PATH *package-path*

Specifies the packagepath to use when the function is run. This is the list of the possible package collections into which the DBRM this is associated with the function is bound.

NO PACKAGE PATH

Specifies that the list of package collections for the function is the same as the list of package collection IDs for the program that invokes the function. If the program that invokes the function does not use a package, Db2 resolves the package by using the CURRENT PACKAGE PATH special register, the CURRENT PACKAGESET special register, or the PKLIST bind option (in this order). For information about how Db2 uses these three items, see [Binding an application plan \(Db2 Application programming and SQL\)](#).

PACKAGE PATH *package-path*

Specifies a list of package collections, in the same format as the SET CURRENT PACKAGE PATH special register.

If the COLLID clause is specified with PACKAGE PATH, the COLLID clause is ignored when the function is invoked.

The *package-path* value that is provided when the function is created is checked when the function is invoked. If *package-path* contains SESSION_USER (or USER), PATH, or PACKAGE PATH, an error is returned when the *package-path* value is checked.

NO SCRATCHPAD or SCRATCHPAD

Specifies whether Db2 provides a scratchpad for the function. It is strongly recommended that functions be reentrant, and a scratchpad provides an area for the function to save information from one invocation to the next.

NO SCRATCHPAD

Specifies that a scratchpad is not allocated and passed to the function. NO SCRATCHPAD is the default.

SCRATCHPAD *length*

Specifies that when the function is invoked for the first time, Db2 allocates memory for a scratchpad. A scratchpad has the following characteristics:

- *length* must be in the range 1–32767. The default value is 100 bytes.
- Db2 initializes the scratchpad to all binary zeros (X'00's).

- The scope of a scratchpad is the SQL statement. Each reference to the function in an SQL statement has a scratchpad. For example, assuming that function UDFX was defined with the SCRATCHPAD keyword, two scratchpads are allocated for the two references to UDFX in the following SQL statement:

```
SELECT *
FROM TABLE (UDFX(A)), TABLE (UDFX(B));
```

- The scratchpad is persistent. Db2 preserves its content from one invocation of the function to the next. Any changes that the function makes to the scratchpad on one call are still there on the next call. Db2 initializes the scratchpads when it begins to execute an SQL statement. Db2 does not reset scratchpads when a correlated subquery begins to execute.
- The scratchpad can be a central point for the system resources that the function acquires. If the function acquires system resources, specify FINAL CALL to ensure that Db2 calls the function one more time so that the function can free those system resources.

Each time the function invoked, Db2 passes an additional argument to the function that contains the address of the scratchpad.

If you specify SCRATCHPAD, Db2:

- Does not move the function from one task control block (TCB) to another between FETCH operations.
- Does not allow another function or stored procedure to use the TCB until the cursor is closed. This is also applicable for cursors declared WITH HOLD.

NO FINAL CALL or FINAL CALL

Specifies whether a *first call* and a *final call* are made to the function.

NO FINAL CALL

A first call and final call are not made to the function. NO FINAL CALL is the default.

FINAL CALL

A first call and final call are made to the function in addition to one or more *open*, *fetch*, or *close calls*.

The types of calls are:

First call

A *first call* occurs only if the function was defined with FINAL CALL. Before a first call, the scratchpad is set to binary zeros. Argument values are passed to the function, and the function might acquire memory or perform other one-time only resource initialization. However, the function should not return any data to Db2, but it can set return values for the SQL-state and diagnostic-message arguments.

Open call

An *open call* occurs unless the function returns an error. The scratchpad is set to binary zeros only if the function was defined with NO FINAL CALL. Argument values are passed to the function, and the function might perform any one-time initialization actions that are required. However, the function should not return any data to Db2.

Fetch call

A *fetch call* occurs unless the function returns an error during the first call or open call. Argument values are passed to the function, and Db2 expects the function to return a row of data or the end-of-table condition. If a scratchpad is also passed to the function, it remains untouched from the previous call.

Close call

A *close call* occurs unless the function returns an error during the first call, open call, or fetch call. No SQL-argument or SQL-argument-ind values are passed to the function, and if the function attempts to examine these values, unpredictable results might occur. If a scratchpad is also passed to the function, it remains untouched from the previous call.

The function should not return any data to Db2, but it can set return values for the SQL-state and diagnostic-message arguments. Also on close call, a function that is defined with NO FINAL CALL

should release any system resources that it acquired. (A function that is defined with FINAL CALL should release any acquired resources on the final call.)

Final

The *final call* balances the first call, and like the first call, occurs only if the function was defined with FINAL CALL. The function can set return values for the SQL-state and diagnostic-message arguments. The function should also release any system resources that it acquired. A final call occurs at these times:

- *End of statement*: When the cursor is closed for cursor-oriented statements, or the execution of the statement has completed.
- *End of transaction*: When normal end of statement processing does not occur. For example, the logic of an application, for some reason, bypasses closing the cursor.

If a commit, rollback, or abort operation causes the final call, the function cannot issue any SQL statements when it is invoked.

DISALLOW PARALLEL

Specifies that Db2 does not consider parallelism for the function.

NO DBINFO or DBINFO

Specifies whether additional status information is passed to the function when it is invoked.

NO DBINFO

No additional information is passed. NO DBINFO is the default.

DBINFO

An additional argument is passed when the function is invoked. The argument is a structure that contains information such as the application run time authorization ID, the schema name, the name of a table or column that the function might be inserting into or updating, and identification of the database server that invoked the function. For details about the argument and its structure, see [DBINFO structure \(Db2 Application programming and SQL\)](#).

CARDINALITY *integer*

Specifies an estimate of the expected number of rows that the function returns. The number is used for optimization purposes. The value of *integer* must range 0–2147483647.

If you do not specify CARDINALITY, Db2 assumes a finite value. The finite value is the same value that Db2 assumes for tables for which the RUNSTATS utility has not gathered statistics.

If a function has an infinite cardinality—the function never returns the "end-of-table" condition and always returns a row, then a query that requires the "end-of-table" to work correctly will need to be interrupted. Thus, avoid using such functions in queries that involve GROUP BY and ORDER BY.

NO COLLID or COLLID *collection-id*

Identifies the package collection that is to be used when the function is executed. This is the package collection into which the DBRM that is associated with the function program is bound.

NO COLLID

The package collection for the function is the same as the package collection of the program that invokes the function. If a trigger invokes the function, the collection of the trigger package is used. If the invoking program does not use a package, Db2 resolves the package by using the CURRENT PACKAGE PATH special register, the CURRENT PACKAGESET special register, or the PKLIST bind option (in this order). For details about how Db2 uses these three items, see the information on package resolution in [Overriding the values that Db2 uses to resolve package lists \(Db2 Application programming and SQL\)](#).

NO COLLID is the default.

COLLID *collection-id*

The name of the package collection that is to be used when the external is executed.

WLM ENVIRONMENT

Identifies the WLM (workload manager) application environment in which the function is to run. The *name* of the WLM environment is an SQL identifier.

If you do not specify WLM ENVIRONMENT, the function runs in the WLM-established stored procedure address space that is specified at installation time.

name

The WLM environment in which the function must run. If another user-defined function or a stored procedure calls the function and that calling routine is running in an address space that is not associated with the WLM environment, Db2 routes the function request to a different address space.

(name,*)

When an SQL application program directly invokes the function, the WLM environment in which the function runs.

If another user-defined function or a stored procedure calls the function, the function runs in same environment that the calling routine uses. In this case, authorization to run the function in the WLM environment is not checked because the authorization of the calling routine suffices.

Users must have the appropriate authorization to execute functions in the specified WLM environment.

ASUTIME

Specifies the total amount of processor time, in CPU service units, that a single invocation of the function can run. The value is unrelated to the ASUTIME column of the resource limit specification table.

When you are debugging a function, setting a limit can be helpful if the function gets caught in a loop. For information on service units, see [z/OS MVS Initialization and Tuning Guide](#).

NO LIMIT

There is no limit on the service units. NO LIMIT is the default.

LIMIT *integer*

The limit on the number of CPU service units is a positive *integer* in the range 1–2147483647. If the procedure uses more service units than the specified value, Db2 cancels the procedure. The CPU cycles that are consumed by parallel tasks in a procedure do not contribute towards the specified ASUTIME LIMIT.

STAY RESIDENT

Specifies whether the load module for the function is to remain resident in memory when the function ends.

NO

The load module is deleted from memory after the function ends. Use NO for non-reentrant functions. NO is the default.

YES

The load module remains resident in memory after the function ends. Use YES for reentrant functions.

PROGRAM TYPE

Specifies whether the function program runs as a main routine or a subroutine.

SUB

The function runs as a subroutine. SUB is the default.

MAIN

The function runs as a main routine.

SECURITY

Specifies how the function interacts with an external security product, such as RACF, to control access to non-SQL resources.

Db2

The function does not require an external security environment. If the function accesses resources that an external security product protects, the access is performed using the authorization ID that is associated with the WLM-established stored procedure address space.

Db2 is the default.

USER

An external security environment should be established for the function. If the function accesses resources that the external security product protects, the access is performed using the primary authorization ID of the process that invoked the function.

DEFINER

An external security environment should be established for the function. If the function accesses resources that the external security product protects, the access is performed using the authorization ID of the owner of the function.

RUN OPTIONS *runtime-options*

Specifies the Language Environment run time options to be used for the function. You must specify *runtime-options* as a character string that is no longer than 254 bytes. If you do not specify RUN OPTIONS or pass an empty string, Db2 does not pass any run time options to Language Environment, and Language Environment uses its installation defaults.

For a description of the Language Environment run time options, see [Language Environment Programming Reference \(z/OS Language Environment Programming Reference\)](#).

INHERIT SPECIAL REGISTERS or DEFAULT SPECIAL REGISTERS

Specifies how special registers are set on entry to the routine.

INHERIT SPECIAL REGISTERS

Specifies that the values of special registers are inherited according to the rules listed in the table for characteristics of special registers in a user-defined function in [“Special registers in a user-defined function or a stored procedure” on page 215](#).

DEFAULT SPECIAL REGISTERS

Specifies that special registers are initialized to the default values, as indicated by the rules in the table for characteristics of special registers in a user-defined function in [“Special registers in a user-defined function or a stored procedure” on page 215](#).

STATIC DISPATCH

At function resolution time, Db2 chooses a function based on the static (or declared) types of the function parameters. STATIC DISPATCH is the default.

STOP AFTER SYSTEM DEFAULT FAILURES, STOP AFTER *nn* FAILURES, or CONTINUE AFTER FAILURE

Specifies whether the routine is to be put in a stopped state after some number of failures.

STOP AFTER SYSTEM DEFAULT FAILURES

Specifies that this routine should be placed in a stopped state after the number of failures indicated by the value of field MAX ABEND COUNT on installation panel DSNTIPX. This is the default.

STOP AFTER *nn* FAILURES

Specifies that this routine should be placed in a stopped state after *nn* failures. The value *nn* can be an integer 1–32767.

CONTINUE AFTER FAILURE

Specifies that this routine should not be placed in a stopped state after any failure.

NOT SECURED or SECURED

Specifies if the function is considered secure for row access control and column access control.

NOT SECURED

Specifies that the function is not considered as secure for row access control and column access control.

NOT SECURED is the default.

When the function is invoked, the arguments of the function must not reference a column for which a column mask is enabled when the table is using active column access control.

SECURED

Specifies that the function is considered secure for row access control and column access control.

The function must be defined with SECURED when it is referenced in a row permission or a column mask.

Notes for CREATE FUNCTION (external table)

Considerations for all types of user-defined functions:

For considerations that apply to all types of user-defined functions, see [“CREATE FUNCTION statement \(overview\)”](#) on page 1424.

Character string representation considerations:

The PARAMETER VARCHAR clause is specific to LANGUAGE C functions because of the native use of NUL-terminated strings in C. VARCHAR structure representation is useful when character string data is known to contain embedded NUL-terminators. It is also useful when it cannot be guaranteed that character string data does not contain embedded NUL-terminators.

PARAMETER VARCHAR does not apply to fixed length character strings, VARCHAR FOR BIT DATA, CLOB, DBCLOB, or implicitly generated parameters. The clause does not apply to VARCHAR FOR BIT DATA because BIT DATA can contain X'00' characters, and its value representation starts with length information. It does not apply to LOB data because a LOB value representation starts with length information.

PARAMETER VARCHAR does not apply to optional parameters that are implicitly provided to an external function. For example, a CREATE FUNCTION statement for LANGUAGE C must also specify PARAMETER STYLE SQL, which returns an SQLSTATE NULL-terminated character string; that SQLSTATE will not be represented in VARCHAR structured form. Likewise, none of the parameters that represent the qualified name of the function, the specific name of the function, or the SQL diagnostic string that is returned to the database manager will be represented in VARCHAR structured form.

Running external functions in WLM environments:

You can use the WLM ENVIRONMENT clause to identify the address space in which a function or is to run. Using different WLM environments lets you isolate one group of programs from another. For example, you might choose to isolate programs based on security requirements and place all payroll applications in one WLM environment because those applications deal with data, such as employee salaries.

To prevent a user from defining functions in sensitive WLM environments, Db2 invokes the external security manager to determine whether the user has authorization to issue CREATE FUNCTION statements that refer to the specified WLM environment. The following example shows the RACF command that authorizes Db2 user DB2USER1 to register a function on Db2 subsystem DB2A that runs in the WLM environment named PAYROLL.

```
PERMIT DB2A.WLMENV.PAYROLL CLASS(DSNR) ID(DB2USER1) ACCESS(READ)
```

For more information, see [Managing authorizations for creation of stored procedures in WLM environments \(Managing Security\)](#).

Determining if a table function is a generic table function:

To identify if a table function is a generic table function, you can query the SYSIBM.SYSROUTINES catalog table. The function is a generic table function if the value of the RESULT_COLS column is 0 (zero) when the value of the ROUTINETYPE column is 'F' and the value of the FUNCTIONTYPE column is 'T'.

Alternative syntax and synonyms:

To provide compatibility with previously releases of Db2 or other products in the Db2 family, Db2 supports the following alternative syntax:

- VARIANT as a synonym for NOT DETERMINISTIC
- NOT VARIANT as a synonym for DETERMINISTIC
- NOT NULL CALL as a synonym for RETURNS NULL ON NULL INPUT
- NULL CALL as a synonym for CALLED ON NULL INPUT
- PARAMETER STYLE DB2SQL as a synonym for PARAMETER STYLE SQL

- TIMEZONE can be specified as an alternative to TIME ZONE.

Example for CREATE FUNCTION (external table)

The following example registers a table function written to return a row consisting of a single document identifier column for each known document in a text management system. The first parameter matches a given subject area and the second parameter contains a given string.

Within the context of a single session, the table function always returns the same table; therefore, it is defined as DETERMINISTIC. In addition, the DISALLOW PARALLEL keyword is added because table functions cannot operate in parallel.

Although the size of the output for DOCMATCH is highly variable, CARDINALITY 20 is a representative value and is specified to help Db2.

```
CREATE FUNCTION DOCMATCH (VARCHAR(30), VARCHAR(255))
    RETURNS TABLE (DOC_ID CHAR(16))
    EXTERNAL NAME ABC
    LANGUAGE C
    PARAMETER STYLE SQL
    NO SQL
    DETERMINISTIC
    NO EXTERNAL ACTION
    FENCED
    SCRATCHPAD
    FINAL CALL
    DISALLOW PARALLEL
    CARDINALITY 20;
```

Example 2: The following example registers a generic table function:

```
CREATE FUNCTION tf6(p1 VARCHAR(10))
    RETURNS GENERIC TABLE
    EXTERNAL NAME 'tf6'
    LANGUAGE C
    PARAMETER STYLE SQL
    DETERMINISTIC
    NO EXTERNAL ACTION
    FENCED
    SCRATCHPAD
    FINAL CALL;
```

Note that LANGUAGE C must be specified, and the names and data type of the result columns must be declared when the table function is referenced in the SELECT clause.

Related concepts

[SQL table functions \(Db2 Application programming and SQL\)](#)

[Naming conventions](#)

The rules for forming a name depend on the type of the object designated by the name.

Related tasks

[Creating a user-defined function \(Db2 Application programming and SQL\)](#)

CREATE FUNCTION statement (inlined SQL scalar function)

The CREATE FUNCTION (inlined SQL scalar) statement defines an SQL scalar function at the current server and specifies an SQL procedural language RETURN statement for the body of the function. The function returns a single value each time it is invoked.

A package is not created for an inlined SQL scalar function. The function is not invoked as part of a query; instead, the *expression* in the RETURN statement of the function is copied (inlined) into the query itself.

Invocation for CREATE FUNCTION (inlined SQL scalar)

This statement can be embedded in an application program or issued interactively. It is an executable statement that can be dynamically prepared only if DYNAMICRULES RUN behavior is in effect. For more information, see [“Authorization IDs and dynamic SQL” on page 94](#).

Authorization for CREATE FUNCTION (inlined SQL scalar)

The privilege set defined below must include at least one of the following:

- The CREATEIN privilege on the schema
- SYSADM or SYSCTRL authority
- System DBADM
- Installation SYSOPR authority (when the current SQLID of the process is set to SYSINSTL)

The authorization ID that matches the schema name implicitly has the CREATEIN privilege on the schema.

If the authorization ID that is used to create the function has the installation SYSADM authority or the installation SYSOPR authority and if the current SQLID is set to SYSINSTL, the function is identified as system-defined function.

If a user-defined type is referenced (as the data type of a parameter), the privilege set must also include at least one of the following:

- Ownership of the user-defined type
- The USAGE privilege on the user-defined type
- SYSADM authority

At least one of the following additional privileges is required if the SECURED option is specified:

- SECADM authority
- CREATE_SECURE_OBJECT privilege

Privilege set: If the statement is embedded in an application program, the privilege set is the privileges that are held by the owner of the plan or package. If the owner is a role, the implicit schema match does not apply and this role needs to include one of the previously listed conditions.

If the statement is dynamically prepared and is not running in a trusted context for which the ROLE AS OBJECT OWNER clause is specified, the privilege set is the set of privileges that are held by the SQL authorization ID of the process. If the schema name is not the same as the SQL authorization ID of the process, one of the following conditions must be met:

- The privilege set includes SYSADM or SYSCTRL authority.
- The SQL authorization ID of the process has the CREATEIN privilege on the schema.

Syntax for CREATE FUNCTION (inlined SQL scalar)

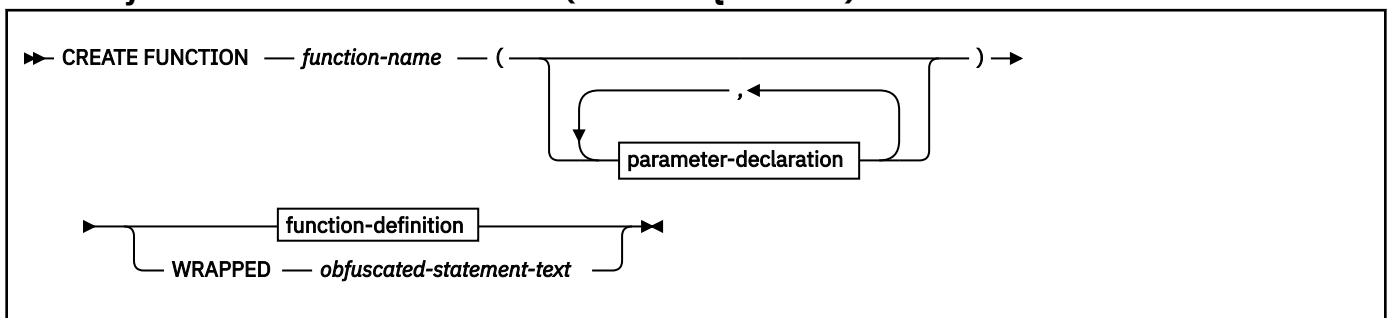

parameter-declaration:

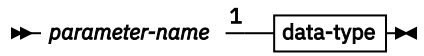

Notes:

¹ Note that the *parameter-name* is required for SQL functions.

data-type:

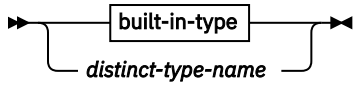

built-in-type:

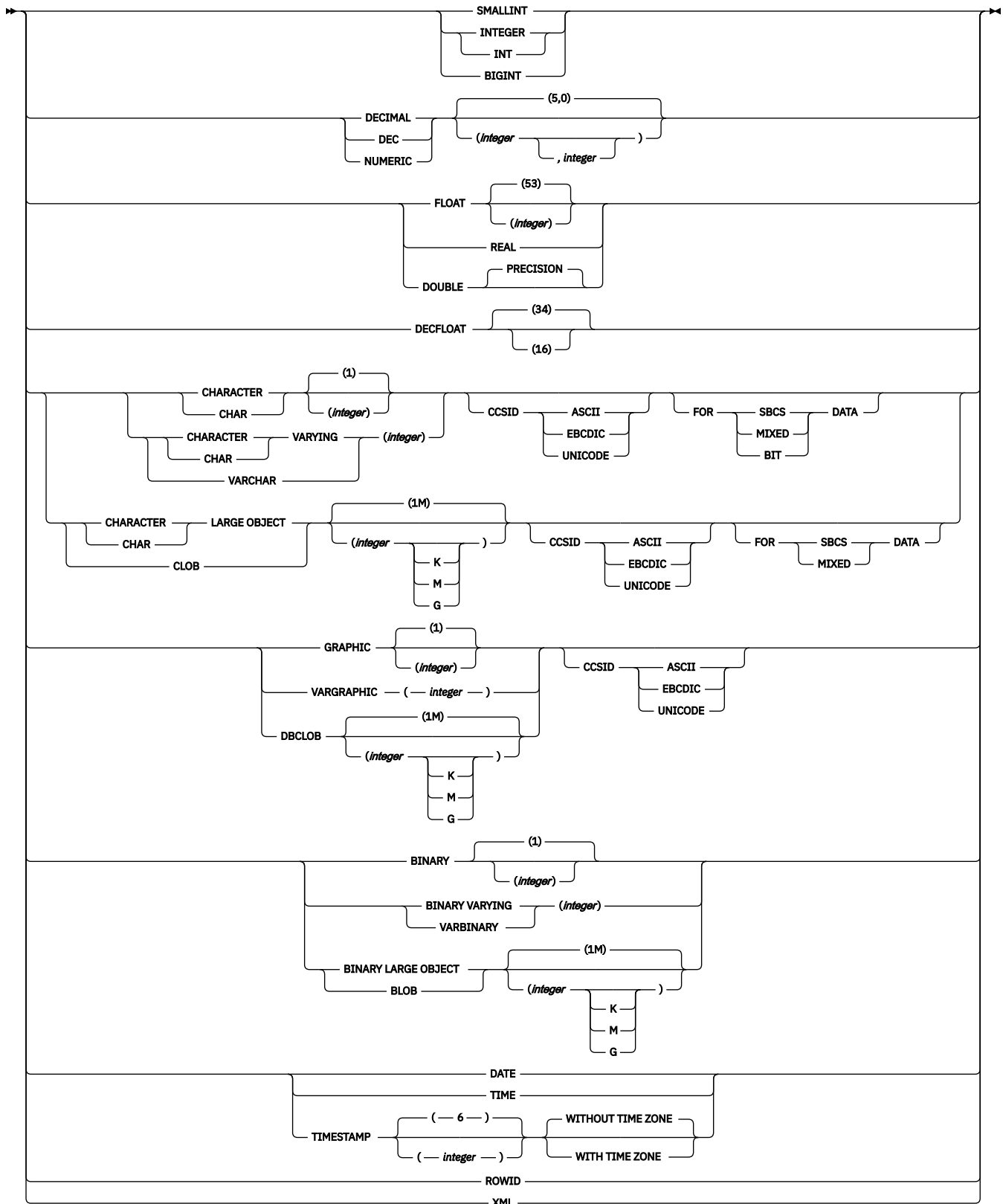

option-list:

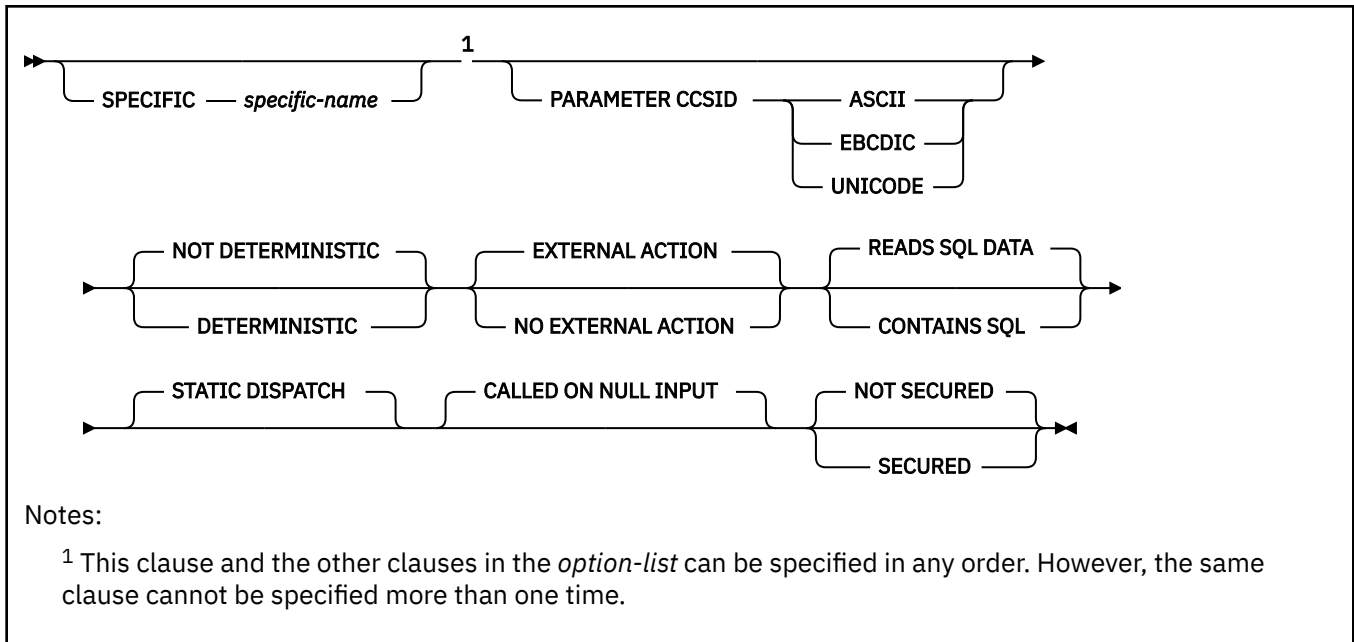

function-definition

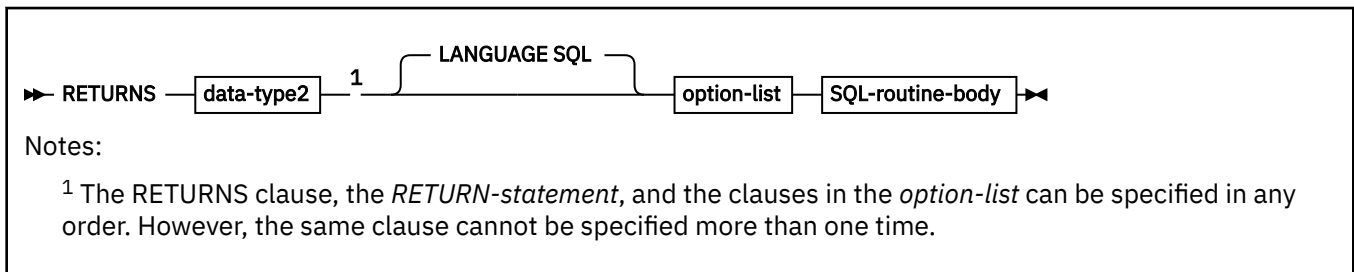

SQL-routine-body

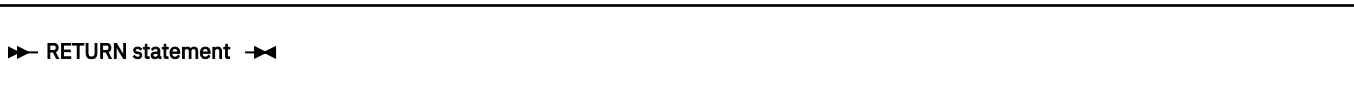

Description for CREATE FUNCTION (inlined SQL scalar)

function-name

Names the user-defined function. The name is implicitly or explicitly qualified by a schema name. For more information, see "Choosing the schema and function names" and "Determining the uniqueness of functions in a schema" in ["CREATE FUNCTION statement \(overview\)"](#) on page 1424.

(parameter-declaration,...)

Specifies the number of input parameters of the function and the name and data type of each parameter. Each *parameter-declaration* specifies an input parameter for the function. A function can have zero or more input parameters. There must be one entry in the list for each parameter that the function expects to receive. All of the parameters for a function are input parameters and are nullable. If the function has more than 30 parameters, only the first 30 parameters are used to determine if the function is unique.

parameter-name

Specifies the name of the input parameter. The name is an SQL identifier, and each name in the parameter list must not be the same as any other name.

data-type

Specifies the data type of the input parameter. The data type can be a built-in data type or a user-defined type.

built-in-type

The data type of the input parameter is a built-in data type.

For information on the data types, see [“built-in-type” on page 1663](#).

For parameters with a character or graphic data type, the PARAMETER CCSID clause or CCSID clause indicates the encoding scheme of the parameter. If you do not specify either of these clauses, the encoding scheme is the value of field DEF ENCODING SCHEME on installation panel DSNTIPF.

distinct-type-name

The data type of the input parameter is a distinct type. Any length, precision, scale, subtype, or encoding scheme attributes for the parameter are those of the source type of the distinct type. The distinct type must not be based on a LOB data type.

If you specify the name of the distinct type without a schema name, Db2 resolves the distinct type by searching the schemas in the SQL path.

The implicitly or explicitly specified encoding scheme of all of the parameters with a character or graphic string data type must be the same—either all ASCII, all EBCDIC, or all UNICODE.

Although parameters with a character data type have an implicitly or explicitly specified subtype (BIT, SBCS, or MIXED), the function program can receive character data of any subtype. Therefore, conversion of the input data to the subtype of the parameter might occur when the function is invoked. An error occurs if mixed data that actually contains DBCS characters is used as the value for an input parameter that is declared with an SBCS subtype.

Parameters with a datetime data type or a distinct type are passed to the function as a different data type:

- A datetime type parameter is passed as a character data type, and the data is passed in ISO format.

The encoding scheme for a datetime type parameter is the same as the implicitly or explicitly specified encoding scheme of any character or graphic string parameters. If no character or graphic string parameters are passed, the encoding scheme is the value of field DEF ENCODING SCHEME on installation panel DSNTIPF.

- A distinct type parameter is passed as the source type of the distinct type.

RETURNS

Identifies the output of the function.

data-type2

Specifies the data type of the output. The output is nullable.

The same considerations that apply to the data type of input parameter, as described under "*data-type*" in [“data-type” on page 1493](#), apply to the data type of the output of the function.

LANGUAGE SQL

Specifies that the function is written exclusively in SQL.

SPECIFIC specific-name

Specifies a unique name for the function. The name is implicitly or explicitly qualified with a schema name. The name, including the schema name, must not identify the specific name of another function that exists at the current server.

The unqualified form of *specific-name* is an SQL identifier. The qualified form is an SQL identifier (the schema name) followed by a period and an SQL identifier.

If you do not specify a schema name, it is the same as the explicit or implicit schema name of the function name (*function-name*). If you specify a schema name, it must be the same as the explicit or implicit schema name of the function name.

If you do not specify the SPECIFIC clause, the default specific name is the name of the function. However, if the function name does not provide a unique specific name or if the function name is a single asterisk, Db2 generates a specific name in the form of:

```
SQLxxxxxxxxxxxxx
```

where 'xxxxxxxxxxxxx' is a string of 12 characters that make the name unique.

The specific name is stored in the SPECIFIC column of the SYSROUTINES catalog table. The specific name can be used to uniquely identify the function in several SQL statements (such as ALTER FUNCTION, COMMENT, DROP, GRANT, and REVOKE) and must be used in Db2 commands (START FUNCTION, STOP FUNCTION, and DISPLAY FUNCTION). However, the function cannot be invoked by its specific name.

PARAMETER CCSID

Indicates whether the encoding scheme for character and graphic string parameters is ASCII, EBCDIC, or UNICODE. The default encoding scheme is the value specified in the CCSID clauses of the parameter list or RETURNS clause, or in the field DEF ENCODING SCHEME on installation panel DSNTIPF.

This clause provides a convenient way to specify the encoding scheme for character and graphic string parameters. If individual CCSID clauses are specified for individual parameters in addition to this PARAMETER CCSID clause, the value specified in *all* of the CCSID clauses must be the same value that is specified in this clause.

This clause also specifies the encoding scheme to be used for system-generated parameters of the routine such as message tokens and DBINFO.

NOT DETERMINISTIC or DETERMINISTIC

Specifies whether the function returns the same results each time that the function is invoked with the same input arguments.

NOT DETERMINISTIC

The function might not return the same result each time that the function is invoked with the same input arguments. The function depends on some state values that affect the results. Db2 uses this information to disable the merging of views and table expressions when processing SELECT and SQL data change statements that refer to this function. An example of a function that is not deterministic is one that generates random numbers.

NOT DETERMINISTIC must be specified explicitly or implicitly if the function program accesses a special register or invokes another function that is not deterministic. NOT DETERMINISTIC is the default.

DETERMINISTIC

The function always returns the same result function each time that the function is invoked with the same input arguments. An example of a deterministic function is a function that calculates the square root of the input. Db2 uses this information to enable the merging of views and table expressions for SELECT and SQL data change statements that refer to this function. DETERMINISTIC is not the default. If applicable, specify DETERMINISTIC to prevent non-optimal access paths from being chosen for SQL statements that refer to this function.

Db2 does not verify that the function program is consistent with the specification of DETERMINISTIC or NOT DETERMINISTIC.

EXTERNAL ACTION or NO EXTERNAL ACTION

Specifies whether the function takes an action that changes the state of an object that Db2 does not manage. An example of an external action is sending a message or writing a record to a file.

EXTERNAL ACTION

The function can take an action that changes the state of an object that Db2 does not manage.

Some SQL statements that invoke functions with external actions can result in incorrect results if parallel tasks execute the function. For example, if the function sends a note for each initial call to

it, one note is sent for each parallel task instead of once for the function. Specify the `DISALLOW PARALLEL` clause for functions that do not work correctly with parallelism.

If you specify `EXTERNAL ACTION`, then Db2:

- Materializes the views and table expressions in `SELECT` and SQL data change statements that refer to the function. This materialization can adversely affect the access paths that are chosen for the SQL statements that refer to this function. Do not specify `EXTERNAL ACTION` if the function does not have an external action.
- Does not move the function from one task control block (TCB) to another between `FETCH` operations.
- Does not allow another function or stored procedure to use the TCB until the cursor is closed. This is also applicable for cursors declared `WITH HOLD`.

The only changes to resources made outside of Db2 that are under the control of commit and rollback operations are those changes made under RRS control.

`EXTERNAL ACTION` must be specified implicitly or explicitly specified if the SQL routine body invokes a function that is defined with `EXTERNAL ACTION`. `EXTERNAL ACTION` is the default.

NO EXTERNAL ACTION

The function does not take any action that changes the state of an object that Db2 does not manage. Db2 uses this information to enable the merging of views and table expressions for `SELECT` and SQL data change statements that refer to this function. If applicable, specify `NO EXTERNAL ACTION` to prevent non-optimal access paths from being chosen for SQL statements that refer to this function.

Although the scope of global variables are beyond the scope of the routine, global variables can be set in the routine body when `NO EXTERNAL ACTION` is specified.

Db2 does not verify that the function program is consistent with the specification of `EXTERNAL ACTION` or `NO EXTERNAL ACTION`.

READS SQL DATA or CONTAINS SQL

Specifies the classification of SQL statements and nested routines that this routine can execute or invoke. The database manager verifies that the SQL statements issued by the function, and all routines locally invoked by the routine, are consistent with this specification; the verification is not performed when nested remote routines are invoked. For the classification of each statement, see [Appendix D, "SQL statement data access classification for routines,"](#) on page 2275.

READS SQL DATA

Specifies that the function can execute statements with a data access classification of `READS SQL DATA`, `CONTAINS SQL`, or `NO SQL`. The function cannot execute SQL statements that modify data.

`READS SQL DATA` is the default.

CONTAINS SQL

Specifies that the function can execute only SQL statements with a data access classification of `CONTAINS SQL` or `NO SQL`. The function cannot execute SQL statements that read or modify data.

STATIC DISPATCH

At function resolution time, Db2 chooses a function based on the static (or declared) types of the function parameters. `STATIC DISPATCH` is the default.

CALLED ON NULL INPUT

Specifies that the function is to be invoked if any, or if all, of the argument values are null. Specifying `CALLED ON NULL INPUT` means that the body of the function must be coded to test for null argument values.

`CALLED ON NULL INPUT` is the default.

NOT SECURED or SECURED

Specifies if the function is considered secure for row access control and column access control. The `SECURED` or `NOT SECURED` option applies to all future versions of the function.

NOT SECURED

Specifies that the function is not considered secure for row access control and column access control.

NOT SECURED is the default.

When the function is invoked, the arguments of the function must not reference a column for which a column mask is enabled when the table is using active column access control.

SECURED

Specifies that the function is considered secure for row access control and column access control.

The function must be secure when it is referenced in a row permission or a column mask.

SQL-routine-body

Specifies a single RETURN statement. For more information, see [“RETURN statement”](#) on page 2240.

If the RETURN statement includes a scalar fullselect, Db2 attempts to define a compiled function. For more information, see [“CREATE FUNCTION statement \(compiled SQL scalar function\)”](#) on page 1428.

To determine what type of SQL scalar function is created, refer to the INLINE column of the SYSIBM.SYSROUTINES catalog table.

WRAPPED obfuscated-statement-text

Specifies the encoded definition of the function. A CREATE FUNCTION statement can be encoded using the WRAP scalar function.

WRAPPED must not be specified on a static CREATE statement.

Notes for CREATE FUNCTION (inlined SQL scalar)**Considerations for all types of user-defined functions:**

For considerations that apply to all types of user-defined functions, see [“CREATE FUNCTION statement \(overview\)”](#) on page 1424.

Types of SQL scalar functions:

If the syntax of the CREATE FUNCTION statement conforms to the syntax diagrams and descriptions for CREATE FUNCTION (inlined SQL scalar), Db2 defines an inlined function, and a package is not created. When an inlined SQL scalar function is invoked, the *expression* in the RETURN statement of the function is copied (inlined) into the query itself; the function is not invoked. The attributes of an inlined SQL scalar function are described in [“CREATE FUNCTION statement \(inlined SQL scalar function\)”](#) on page 1489.

Otherwise, Db2 attempts to define a compiled function with an associated package. For example, if the RETURN statement contains a scalar fullselect, Db2 attempts to define a compiled function. The attributes of a compiled SQL scalar function are described in [“CREATE FUNCTION statement \(compiled SQL scalar function\)”](#) on page 1428.

To determine what type of SQL scalar function is created, refer to the INLINE column of the SYSIBM.SYSROUTINES catalog table. In the INLINE column, a value of Y indicates that the function is an inlined function, and a value of N indicates that the function is a compiled function.

Considerations for functions defined with MODIFIES SQL DATA:

If a function is specified in a subselect, and the function is defined as MODIFIES SQL DATA, the number of times the function is invoked will vary depending on the access plan used.

Self-referencing function:

The body of an SQL function (that is, the *expression* or NULL in the RETURN statement in the body of the CREATE FUNCTION statement) cannot contain a recursive invocation of itself or to another function that invokes it, because such a function would not exist to be referenced.

Dependent objects:

An SQL routine is dependent on objects that are referenced in the routine body.

Obfuscated statements:

A CREATE FUNCTION statement can be executed in obfuscated form. In an obfuscated statement, only the function name, parameters, and the WRAPPED keyword are readable. The rest of the statement is encoded in such a way that it is not readable but can be decoded by a database server that supports obfuscated statements. The WRAP scalar function produces obfuscated statements. Any debug options that are specified when the function is created from an obfuscated statement are ignored.

Resolution of object names:

Db2 resolves object names inside the body of the function according to the rules in [“Unqualified object name resolution”](#) on page 86 and the type of the object. The name resolution occurs when the function is created.

Referencing date and time special registers:

If an SQL function contains multiple references to any of the date or time special registers, all references return the same value. In addition, this value is the same value that is returned by the retrieving value of the special register in the statement that invoked the function.

Self-referencing function:

The body of an SQL function (that is, the *expression* or NULL in the RETURN clause of the CREATE FUNCTION (inlined SQL scalar) statement) cannot contain a recursive invocation of itself or to another function that invokes it, because such a function would not exist to be referenced.

Dependent objects:

An SQL routine is dependent on objects that are referenced in the routine body.

Alternative syntax and synonyms:

To provide compatibility with previous releases of Db2 or other products in the Db2 family, Db2 supports the following alternative syntax:

- VARIANT as a synonym for NOT DETERMINISTIC
- NOT VARIANT as a synonym for DETERMINISTIC
- NULL CALL as a synonym for CALLED ON NULL INPUT
- TIMEZONE can be specified as an alternative to TIME ZONE.

For an inlined SQL scalar function, the RETURNS clause and the clauses in the *option-list* can be specified in any order.

Examples for CREATE FUNCTION (inlined SQL scalar)

Example 1: Define a scalar function that returns the tangent of a value using existing SIN and COS built-in functions:

```
CREATE FUNCTION TAN (X DOUBLE)
  RETURNS DOUBLE
  LANGUAGE SQL
  CONTAINS SQL
  NO EXTERNAL ACTION
  DETERMINISTIC
  RETURN SIN(X)/COS(X);
```

CREATE FUNCTION statement (sourced function)

This CREATE FUNCTION statement registers a user-defined function that is based on an existing scalar or aggregate function with a database server.

Invocation for CREATE FUNCTION (sourced)

This statement can be embedded in an application program or issued interactively. It is an executable statement that can be dynamically prepared only if DYNAMICRULES RUN behavior is in effect. For more information, see [“Authorization IDs and dynamic SQL”](#) on page 94.

Authorization for CREATE FUNCTION (sourced)

The privilege set defined below must include at least one of the following:

- The CREATEIN privilege on the schema
- SYSADM or SYSCTRL authority
- System DBADM
- Installation SYSOPR authority (when the current SQLID of the process is set to SYSINSTL)

The authorization ID that matches the schema name implicitly has the CREATEIN privilege on the schema.

If the authorization ID that is used to create the function has the installation SYSADM authority or the installation SYSOPR authority and if the current SQLID is set to SYSINSTL, the function is identified as system-defined function.

Additional privileges are required for the source function, and other privileges are also needed if the function uses a table as a parameter, or refers to a distinct type. These privileges are:

- The EXECUTE privilege for the function that the SOURCE clause references.
- The SELECT privilege on any table that is an input parameter to the function.
- The USAGE privilege on each distinct type that the function references.

Privilege set: If the statement is embedded in an application program, the privilege set is the privileges that are held by the owner of the plan or package. If the owner is a role, the implicit schema match does not apply and this role needs to include one of the previously listed conditions.

If the statement is dynamically prepared and is not running in a trusted context for which the ROLE AS OBJECT OWNER clause is specified, the privilege set is the set of privileges that are held by the SQL authorization ID of the process. If the schema name is not the same as the SQL authorization ID of the process, one of the following conditions must be met:

- The privilege set includes SYSADM or SYSCTRL authority.
- The SQL authorization ID of the process has the CREATEIN privilege on the schema.

Syntax for CREATE FUNCTION (sourced)

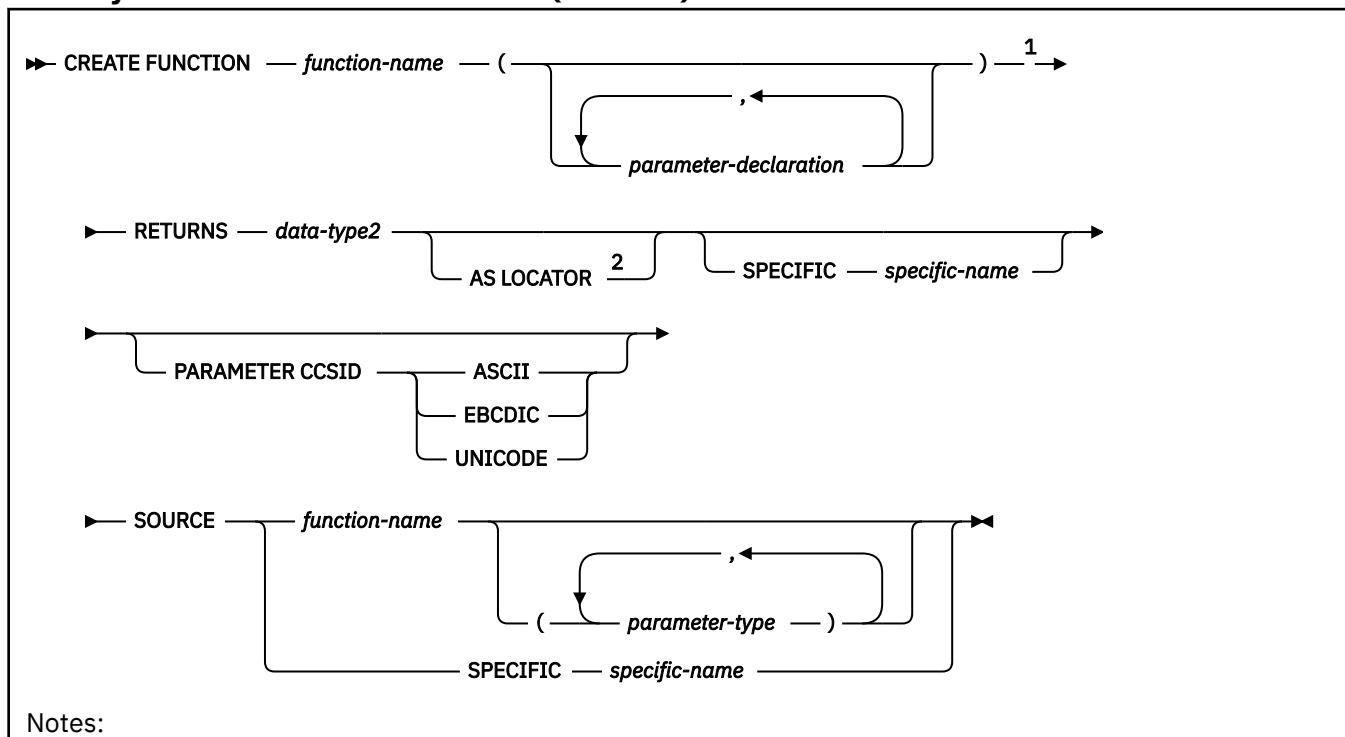

¹ RETURNS, SPECIFIC, and SOURCE can be specified in any order.

² AS LOCATOR can be specified only for a LOB data type or a distinct type based on a LOB data type.

parameter-declaration:

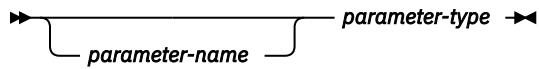

parameter-type:

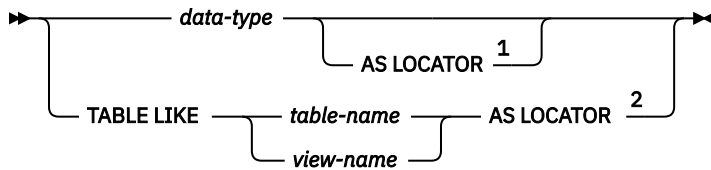

Notes:

¹ AS LOCATOR can be specified only for a LOB data type or a distinct type based on a LOB data type.

² The TABLE LIKE name AS LOCATOR clause can only be specified for the parameter list of the function that is being defined.

data-type:

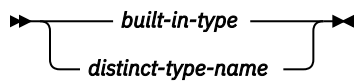

built-in-type:

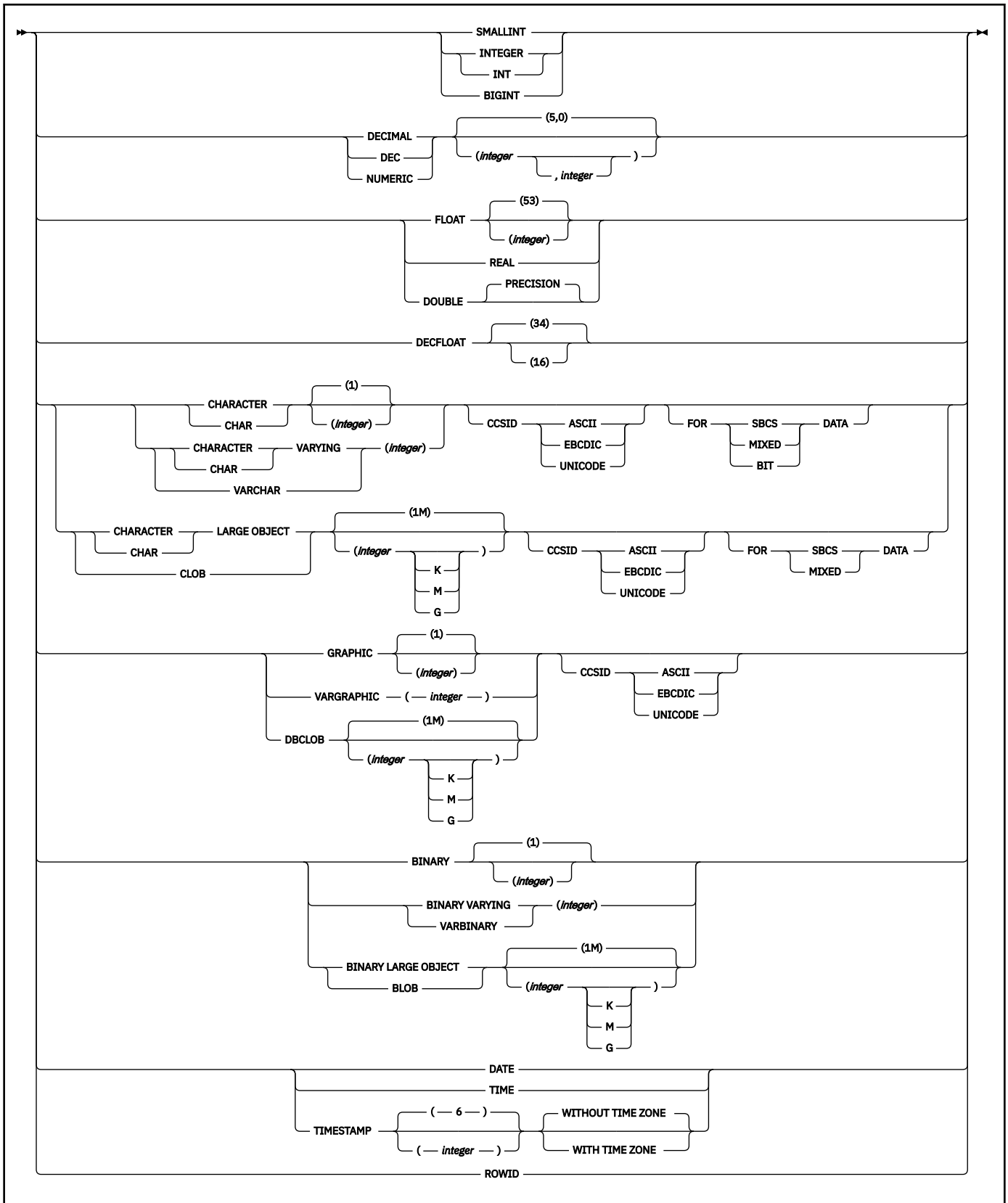

Description for CREATE FUNCTION (sourced)

function-name

Names the user-defined function. The name is implicitly or explicitly qualified by a schema name. For more information, see "Choosing the schema and function names" and "Determining the uniqueness of functions in a schema" in [“CREATE FUNCTION statement \(overview\)”](#) on page 1424.

(parameter-declaration,...)

Specifies the number of input parameters of the function and the data type of each parameter. All of the parameters for a function are input parameters and are nullable. There must be one entry in the list for each parameter that the function expects to receive. Although not required, you can give each parameter a name.

A function can have no parameters. In this case, you must code an empty set of parentheses, for example:

```
CREATE FUNCTION WOOFER()
```

parameter-name

Specifies the name of the input parameter. The name is an SQL identifier, and each name in the parameter list must not be the same as any other name.

data-type

Specifies the data type of the input parameter. The data type can be a built-in data type or a distinct type.

built-in-type

The data type of the input parameter is a built-in data type.

For information on the data types, see [built-in-type](#).

For parameters with a character or graphic data type, the PARAMETER CCSID clause or CCSID clause indicates the encoding scheme of the parameter. If you do not specify either of these clauses, the encoding scheme is the value of field DEF ENCODING SCHEME on installation panel DSNTIPF.

distinct-type-name

The data type of the input parameter is a distinct type. Any length, precision, scale, subtype, or encoding scheme attributes for the parameter are those of the source type of the distinct type.

The implicitly or explicitly specified encoding scheme of all of the parameters with a character or graphic string data type must be the same—either all ASCII, all EBCDIC, or all UNICODE.

Although parameters with a character data type have an implicitly or explicitly specified subtype (BIT, SBCS, or MIXED), the function program can receive character data of any subtype. Therefore, conversion of the input data to the subtype of the parameter might occur when the function is invoked.

Parameters with a datetime data type or a distinct type are passed to the function as a different data type:

- A datetime type parameter is passed as a character data type, and the data is passed in ISO format.

The encoding scheme for a datetime type parameter is the same as the implicitly or explicitly specified encoding scheme of any character or graphic string parameters. If no character or graphic string parameters are passed, the encoding scheme is the value of field DEF ENCODING SCHEME on installation panel DSNTIPF.

- A distinct type parameter is passed as the source type of the distinct type.

You can specify any built-in data type or distinct type that matches or can be cast to the data type of the corresponding parameter of the source function (the function that is identified in the SOURCE clause). (For information on casting data types, see [“Casting between data types”](#) on page 130.) Length, precision, or scale attributes do not have to be specified for data types with these attributes. When specifying data types with these attributes, follow these rules:

- An empty set of parentheses can be used to indicate that the length, precision, or scale is the same as the source function.
- If length, precision, or scale is not explicitly specified, and empty parentheses are not specified, the default values are used.

AS LOCATOR

Specifies that a locator to the value of the parameter is passed to the function instead of the actual value. Specify AS LOCATOR only for parameters with a LOB data type or a distinct type based on a LOB data type. Passing locators instead of values can result in fewer bytes being passed to the function, especially when the value of the parameter is very large.

The AS LOCATOR clause has no effect on determining whether data types can be promoted, nor does it affect the function signature, which is used in function resolution.

TABLE LIKE *table-name* or *view-name* AS LOCATOR

Specifies that the parameter is a transition table. However, when the function is invoked, the actual values in the transition table are not passed to the function. A single value is passed instead. This single value is a locator to the table, which the function uses to access the columns of the transition table. A function with a table parameter can only be invoked from the triggered action of a trigger.

The use of TABLE LIKE provides an implicit definition of the transition table. It specifies that the transition table has the same number of columns as the identified table or view. If a table is specified, the transition table includes columns that are defined as implicitly hidden in the table. The columns have the same data type, length, precision, scale, subtype, and encoding scheme as the identified table or view, as they are described in catalog tables SYSCOLUMNS and SYSTABLESPACE. The number of columns and the attributes of those columns are determined at the time the CREATE FUNCTION statement is processed. Any subsequent changes to the number of columns in the table or the attributes of those columns do not affect the parameters of the function.

table-name or *view-name* must identify a table or view that exists at the current server. A view cannot have columns of length 0. The name must not identify a declared temporary table. The table that is identified can contain XML columns; however, the function cannot reference those XML columns. The name does not have to be the same name as the table that is associated with the transition table for the trigger. An unqualified table or view name is implicitly qualified according to the following rules:

- If the CREATE FUNCTION statement is embedded in a program, the implicit qualifier is the authorization ID in the QUALIFIER bind option when the plan or package was created or last rebound. If QUALIFIER was not used, the implicit qualifier is the owner of the plan or package.
- If the CREATE FUNCTION statement is dynamically prepared, the implicit qualifier is the SQL authorization ID in the CURRENT SCHEMA special register.

When the function is invoked, the corresponding columns of the transition table identified by the table locator and the table or view identified in the TABLE LIKE clause must have the same definition. The data type, length, precision, scale, and encoding scheme of these columns must match exactly. The description of the table or view at the time the CREATE FUNCTION statement was executed is used.

Additionally, a character FOR BIT DATA column of the transition table cannot be passed as input for a table parameter for which the corresponding column of the table specified at the definition is not defined as character FOR BIT DATA. (The definition occurs with the CREATE FUNCTION statement.) Likewise, a character column of the transition table that is not FOR BIT DATA cannot be passed as input for a table parameter for which the corresponding column of the table specified at the definition is defined as character FOR BIT DATA.

For more information about using table locators, see [Accessing transition tables in a user-defined function or stored procedure \(Db2 Application programming and SQL\)](#).

RETURNS

Identifies the output of the function.

data-type2

Specifies the data type of the output. The output is nullable.

You can specify any built-in data type or distinct type that can be cast from the data type of the result of the source function. (For information on casting data types, see [“Casting between data types”](#) on page 130.)

AS LOCATOR

Specifies that the function returns a locator to the value rather than the actual value. You can specify AS LOCATOR only if the output from the function has a LOB data type or a distinct type based on a LOB data type.

SPECIFIC *specific-name*

Provides a unique name for the function. The name is implicitly or explicitly qualified with a schema name. The name, including the schema name, must not identify the specific name of another function that exists at the current server.

The unqualified form of *specific-name* is an SQL identifier. The qualified form is an SQL identifier (the schema name) followed by a period and an SQL identifier.

If you do not specify a schema name, it is the same as the explicit or implicit schema name of the function name (*function-name*). If you specify a schema name, it must be the same as the explicit or implicit schema name of the function name.

If you do not specify the SPECIFIC clause, the default specific name is the name of the function. However, if the function name does not provide a unique specific name or if the function name is a single asterisk, Db2 generates a specific name in the form of:

```
SQLxxxxxxxxxxxx
```

where 'xxxxxxxxxxxx' is a string of 12 characters that make the name unique.

The specific name is stored in the SPECIFIC column of the SYSROUTINES catalog table. The specific name can be used to uniquely identify the function in several SQL statements (such as ALTER FUNCTION, COMMENT, DROP, GRANT, and REVOKE) and in Db2 commands (START FUNCTION, STOP FUNCTION, and DISPLAY FUNCTION). However, the function cannot be invoked by its specific name.

PARAMETER CCSID

Indicates whether the encoding scheme for character and graphic string parameters is ASCII, EBCDIC, or UNICODE. The default encoding scheme is the value specified in the CCSID clauses of the parameter list or RETURNS clause, or in the field DEF ENCODING SCHEME on installation panel DSNTIPF.

This clause provides a convenient way to specify the encoding scheme for character and graphic string parameters. If individual CCSID clauses are specified for individual parameters in addition to this PARAMETER CCSID clause, the value specified in *all* of the CCSID clauses must be the same value that is specified in this clause.

This clause also specifies the encoding scheme to be used for system-generated parameters of the routine such as message tokens and DBINFO.

SOURCE

Specifies that the new function is being defined as a sourced function. A *sourced function* is implemented by another function (the *source function*). The source function must be a scalar or aggregate function that exists at the current server, and it must be one of the following types of functions:

- A function that was defined with a CREATE FUNCTION statement
- A cast function that was generated by a CREATE TYPE statement for a distinct type
- A built-in function

If the source function is not a built-in function, the particular function can be identified by its name, function signature, or specific name.

If the source function is a built-in function, the SOURCE clause must include a function signature for the built-in function.

The source function must not be any of the built-in functions (if a particular syntax is shown, only the indicated form cannot be specified):

- ARRAY_AGG
- ARRAY_DELETE
- ARRAY_FIRST
- ARRAY_LAST
- ARRAY_NEXT
- ARRAY_PRIOR
- CARDINALITY
- CHAR(*datetime-expression*, *second-argument*) where *second-argument* is ISO, USA, EUR, JIS, or LOCAL or if CHAR is specified with OCTETS, CODEUNITS16, or CODEUNITS32.
- CHARACTER_LENGTH
- CLOB if OCTETS, CODEUNITS16, or CODEUNITS32 is specified
- COALESCE if a parameter is an array
- COUNT(*)
- COUNT_BIG(*)
- [FL 504 CUME_DIST](#)
- [FL 504 CUME_DIST](#) (aggregate)
- DBCLOB if OCTETS, CODEUNITS16, or CODEUNITS32 is specified
- DECODE
- DECRYPT_BIT where the second argument is DEFAULT
- DECRYPT_CHAR where the second argument is DEFAULT
- DECRYPT_DB where the second argument is DEFAULT
- DECRYPT_DATAKEY_BIGINT
- DECRYPT_DATAKEY_BIT
- DECRYPT_DATAKEY_CLOB
- DECRYPT_DATAKEY_DBCLOB
- DECRYPT_DATAKEY_DECIMAL
- DECRYPT_DATAKEY_INTEGER
- DECRYPT_DATAKEY_VARCHAR
- DECRYPT_DATAKEY_VARGRAPHIC
- ENCRYPT_DATAKEY
- EXTRACT
- [FL 504 FIRST_VALUE](#)
- GETVARIABLE where the second argument is DEFAULT
- [FL 502 GRAPHIC](#) if OCTETS, CODEUNITS16, or CODEUNITS32 is specified, or if the first argument is numeric
- IFNULL if a parameter is an array
- INSERT if OCTETS, CODEUNITS16, or CODEUNITS32 is specified
- [FL 504 LAG](#)
- [FL 504 LAST_VALUE](#)
- [FL 504 LEAD](#)

- LEFT if OCTETS, CODEUNITS16, or CODEUNITS32 is specified
- [FL 501 LISTAGG](#)
- LOCAL
- LOCATE if OCTETS, CODEUNITS16, or CODEUNITS32 is specified
- MAX
- MAX_CARDINALITY
- MIN
- [FL 504 NTH_VALUE](#)
- [FL 504 NTILE](#)
- NULLIF
- [FL 504 PERCENT_RANK](#)
- [FL 504 PERCENT_RANK](#) (aggregate)
- POSITION
- [FL 504 RATIO_TO_REPORT](#)
- [FL 504 REGEXP_COUNT](#)
- [FL 504 REGEXP_INSTR](#)
- [FL 504 REGEXP_LIKE](#)
- [FL 504 REGEXP_REPLACE](#)
- [FL 504 REGEXP_SUBSTR](#)
- RID
- RIGHT if OCTETS, CODEUNITS16, or CODEUNITS32 is specified
- STRIP where multiple arguments are specified
- SUBSTRING
- TRIM where the first argument is BOTH, B, LEADING, L, TRAILING, T, or the first or second argument is FROM
- TRIM_ARRAY
- VARCHAR if OCTETS, CODEUNITS16, or CODEUNITS32 is specified
- [FL 502 VARGRAPHIC](#) if OCTETS, CODEUNITS16, or CODEUNITS32 is specified, or if the first argument is numeric.
- XMLAGG
- XMLCONCAT
- XMLELEMENT
- XMLFOREST
- XMLNAMESPACES

If you base the sourced function directly or indirectly on an external scalar function, the sourced function inherits the attributes of the external scalar function. This can involve several layers of sourced functions. For example, assume that function A is sourced on function B, which in turn is sourced on function C. Function C is an external scalar function. Functions A and B inherit all of the attributes that are specified on the EXTERNAL clause of the CREATE FUNCTION statement for function C.

function-name

Identifies the function that is to be used as the source function. The source function can be defined with any number of parameters. If more than one function is defined with the specified name in the specified or implicit schema, an error is returned.

If you specify an unqualified *function-name*, Db2 searches the schemas of the SQL path. Db2 selects the first schema that has only one function with this name on which the user has EXECUTE authority. An error is returned if a function is not found or a schema has more than one function with this name.

function-name (parameter-type,...)

Identifies the function that is to be used as the source function by its function signature, which uniquely identifies the function. The *function-name (parameter-type,...)* must identify a function with the specified signature. The specified parameters must match the data types in the corresponding position that were specified when the function was created. Db2 uses the number of data types and the logical concatenation of the data types to identify the specific function instance. Synonyms for data types are considered a match.

If the function was defined with a table parameter (the LIKE TABLE *name* AS LOCATOR clause was specified in the CREATE FUNCTION statement to indicate that one of the input parameters is a transition table), the function signature cannot be used to uniquely identify the function. Instead, use one of the other syntax variations to identify the function with its function name, if unique, or its specific name.

If *function-name()* is specified, the identified function must have zero parameters.

function-name

Identifies the function name of the source function. If you specify an unqualified name, Db2 searches the schemas of the SQL path. Otherwise, Db2 searches for the function in the specified schema.

parameter-type,...

Identifies the parameters of the function.

If an unqualified distinct type name is specified, Db2 searches the SQL path to resolve the schema name for the distinct type.

Empty parentheses are allowed for some data types that are specified in this context. For data types that have a length, precision, or scale attribute, use one of the following specifications:

- Empty parentheses indicate that Db2 ignores the attribute when determining whether the data types match. For example, DEC() is considered a match for a parameter of a function that is defined with a data type of DEC(7,2). However, FLOAT cannot be specified with empty parentheses because its parameter value indicates a specific data type (REAL or DOUBLE).
- If a specific value for a length, precision, or scale attribute is specified, the value must exactly match the value that was specified (implicitly or explicitly) in the CREATE FUNCTION statement. If the data type is FLOAT, the precision does not need to exactly match the value that was specified because matching is based on the data type (REAL or DOUBLE).
- If length, precision, or scale is not explicitly specified, and empty parentheses are not specified, the default attributes of the data type are implied. The implicit length must exactly match the value that was specified (implicitly or explicitly) in the CREATE FUNCTION statement.

If you omit the FOR *subtype* DATA clause or the CCSID clause for data types with a subtype or encoding scheme attribute, Db2 is to ignore the attribute when determining whether the data types match. An exception to ignoring the attribute is FOR BIT DATA. A character FOR BIT DATA parameter of the new function cannot correspond to a parameter of the source function that is not defined as character FOR BIT DATA. Likewise, a character parameter of the new function that is not FOR BIT DATA cannot correspond to a parameter of the source function that is defined as character FOR BIT DATA.

The number of input parameters in the function that is being created must be the same as the number of parameters in the source function. If the data type of each input parameter is not the same as or castable to the corresponding parameter of the source function, an error occurs. The data type of the final result of the source function must match or be castable to the result of the sourced function.

AS LOCATOR

Specifies that the function is defined to receive a locator for this parameter. If AS LOCATOR is specified, the data type must be a LOB or distinct type that is based on a LOB.

SPECIFIC *specific-name*

Identifies the function to be used as the source function by its specific name.

If you specify an unqualified *specific-name*, Db2 searches the SQL path to locate the schema. Db2 selects the first schema that contains a function with this specific name for which the user has EXECUTE authority. Db2 returns an error if it cannot find a function with the specific name in one of the schemas in the SQL path.

If you specify a qualified *specific-name*, Db2 searches the named schema for the function. Db2 returns an error if it cannot find a function with the specific name.

Notes for CREATE FUNCTION (sourced)

Considerations for all types of user-defined functions:

For considerations that apply to all types of user-defined functions, see [“CREATE FUNCTION statement \(overview\)”](#) on page 1424.

Owner privileges for sourced functions:

For sourced functions, the owner is authorized to execute the function (EXECUTE privilege) in the following cases:

- If the underlying function is a user-defined function, and the owner is authorized with the grant option to execute the underlying function, the privilege on the new function includes the grant option. Otherwise, the owner can execute the new function but cannot grant others the privilege to do so.
- If the underlying function is a built-in function, the owner is authorized with the grant option to execute the underlying built-in function and the privilege on the new function includes the grant option.

For more information, see [“GRANT statement \(function or procedure privileges\)”](#) on page 1970. For more information about ownership of the object, see [“Authorization, privileges, permissions, masks, and object ownership”](#) on page 90.

Rules for creating sourced functions:

Assume that the function that is being created is named NEWF and the source function is named SOURCEF. Consider the following rules when creating a sourced function:

- The unqualified names of the sourced function and source function can be different (NEWF and SOURCEF).
- The number of input parameters for NEWF and SOURCEF must be the same.
- When specifying the input parameters and output for NEWF, you can specify a value for the precision, scale, subtype, or encoding scheme for a data type with any of these attributes or use empty parentheses.

Empty parentheses, such as VARCHAR(), indicate that the value of the attribute is the same as the attribute for the corresponding parameter of SOURCEF, or that is determined by data type promotion. If you specify any values for the attributes, Db2 checks the values against the corresponding input parameters and returned output of SOURCEF as described next.

- When the CREATE FUNCTION statement is executed, Db2 checks the input parameters of NEWF against those of SOURCEF. The data type of each input parameter of NEWF function must be either the same as, or promotable to, the data type of the corresponding parameter of SOURCEF. (For information on the promotion of data types, see [“Casting between data types”](#) on page 130.)

This checking does not guarantee that an error will not occur when NEWF is invoked. For example, an argument that matches the data type and length or precision attributes of a NEWF parameter might not be promotable if the corresponding SOURCEF parameter has a shorter length or less precision. In general, do not define the parameters of a sourced function with length or precision

attributes that are greater than the attributes of the corresponding parameters of the source function.

- When the CREATE FUNCTION statement is executed, Db2 checks the data type identified in the RETURNS clause of NEWF against the data type that SOURCEF returns. The data type that SOURCEF returns must be either the same as, or promotable to, the RETURNS data type of NEWF.

This checking does not guarantee that an error will not occur when NEWF is invoked. For example, the value of a result that matches the data type and length or precision attributes of those specified for the SOURCEF result might not be promotable if the RETURNS data type of NEWF has a shorter length or less precision. Consider the possible effects of defining the RETURNS data type of a sourced function with length or precision attributes that are less than the attributes defined for the data type returned by source function.

Secure functions:

The sourced user-defined function inherits the SECURED or NOT SECURED attribute from the source function in which only the topmost user-defined function is considered. If the topmost user-defined function is secure, any nested user-defined functions are also considered secure. Db2 does not validate whether those nested user-defined functions are secure. If those nested functions can access sensitive data, the security administrator needs to ensure that those functions are allowed to access sensitive data and should ensure that a change control audit procedure has been established for all changes to those functions.

If the sourced function is defined with the VERIFY_GROUP_FOR_USER or VERIFY_ROLE_FOR_USER function as its source, the sourced function must specify only two input parameters.

Examples for CREATE FUNCTION (sourced)

Example 1

Assume that you created a distinct type HATSIZE, which you based on the built-in data type INTEGER. You want to have an AVG function to compute the average hat size of different departments. Create a sourced function that is based on built-in function AVG.

```
CREATE FUNCTION AVE (HATSIZE) RETURNS HATSIZE
SOURCE SYSIBM.AVG (INTEGER);
```

When you created distinct type HATSIZE, two cast functions were generated, which allow HATSIZE to be cast to INTEGER for the argument and INTEGER to be cast to HATSIZE for the result of the function.

Example 2

After Smith registered the external scalar function CENTER in his schema, you decide that you want to use this function, but you want it to accept two INTEGER arguments instead of one INTEGER argument and one FLOAT argument. Create a sourced function that is based on CENTER.

```
CREATE FUNCTION MYCENTER (INTEGER, INTEGER)
RETURNS FLOAT
SOURCE SMITH.CENTER (INTEGER, FLOAT);
```

Related concepts

[Sourced functions \(Db2 Application programming and SQL\)](#)

[Naming conventions](#)

The rules for forming a name depend on the type of the object designated by the name.

Related tasks

[Creating a user-defined function \(Db2 Application programming and SQL\)](#)

CREATE FUNCTION statement (SQL table function)

The CREATE FUNCTION (SQL table) statement creates an SQL table function at the current server. The function returns a set of rows.

Invocation for CREATE FUNCTION (SQL table)

This statement can only be dynamically prepared only if dynamic rules run behavior is in effect. For more information, see [“Authorization IDs and dynamic SQL”](#) on page 94.

Authorization for CREATE FUNCTION (SQL table)

The privilege set that is defined below must include at least one of the following privileges or authorities:

- The CREATEIN privilege on the schema
- SYSADM authority
- SYSCTRL authority
- System DBADM
- Installation SYSOPR authority (when the current SQLID of the process is set to SYSINSTL)

The authorization ID that matches the schema name implicitly has the CREATEIN privilege on the schema.

If the authorization ID that is used to create the function has the installation SYSADM authority or the installation SYSOPR authority and if the current SQLID is set to SYSINSTL, the function is identified as system-defined function.

If a distinct type is referenced (i.e. as the data type of a parameter or SQL variable), the privilege set must also include at least one of the following:

- Ownership of the distinct type
- The USAGE privilege on the distinct type
- SYSADM authority
- SYSDBADM authority

If the function uses a table as a parameter, the privilege set must also include at least one of the following:

- Ownership of the table
- The SELECT privilege on the table
- SYSADM authority

At least one of the following additional privileges is required if the SECURED option is specified

- SECADM authority
- CREATE_SECURE_OBJECT privilege

Privilege set: If the statement is embedded in an application program, the privilege set is the set of privileges that are held by the owner of the plan or package. If the owner is a role, matching of the implicit schema name does not apply and the role must include one of the previously listed privileges or authorities.

If the statement is dynamically prepared and is not running in a trusted context for which the ROLE AS OBJECT OWNER clause is specified, the privilege set is the set of privileges that are held by the SQL authorization ID of the process. If the schema name is not the same as the SQL authorization ID of the process, one of the following conditions must be met:

- The privilege set includes SYSADM authority
- The privilege set includes SYSCTRL authority
- The SQL authorization ID of the process has the CREATEIN privilege on the schema

Syntax for CREATE FUNCTION (SQL table)

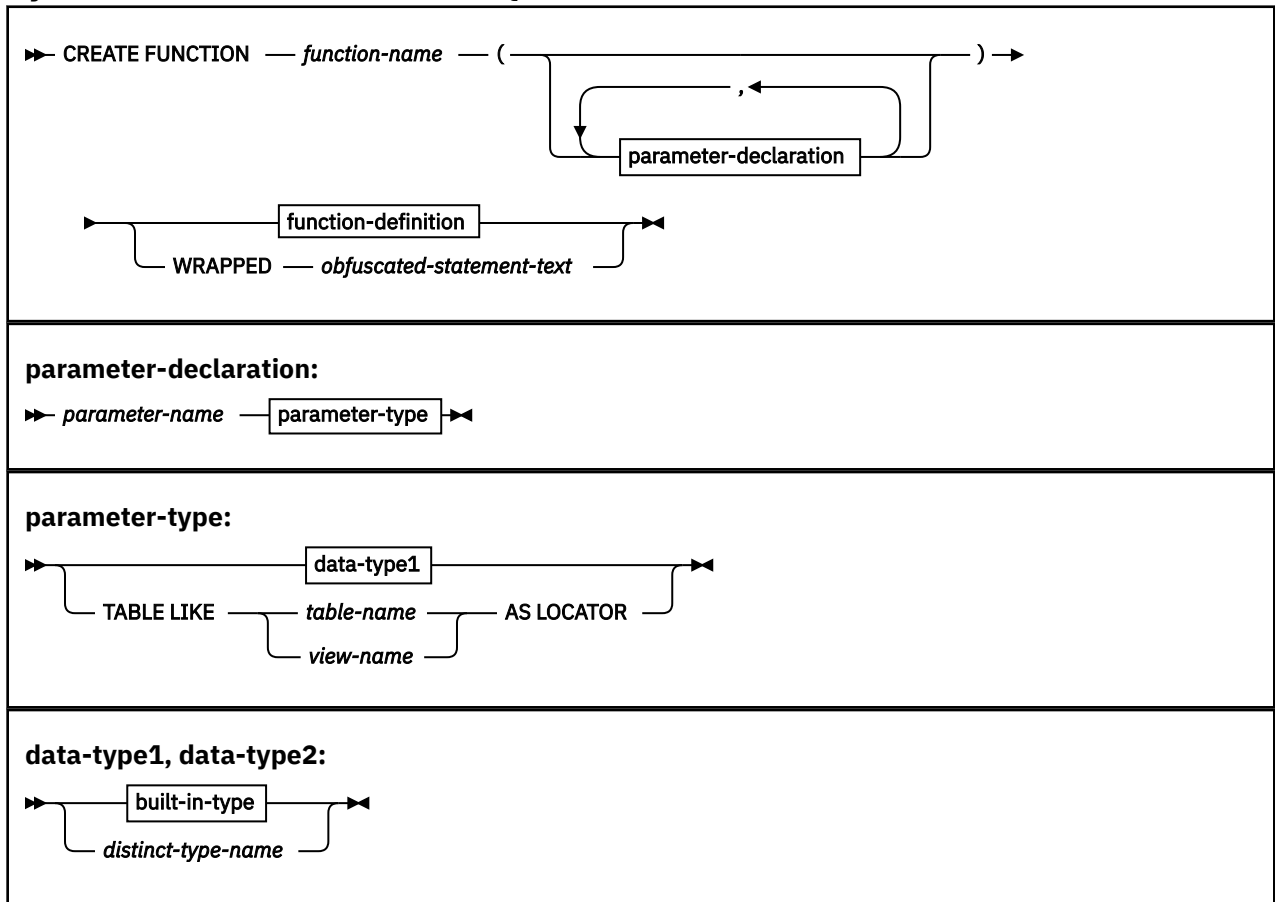

built-in-type:

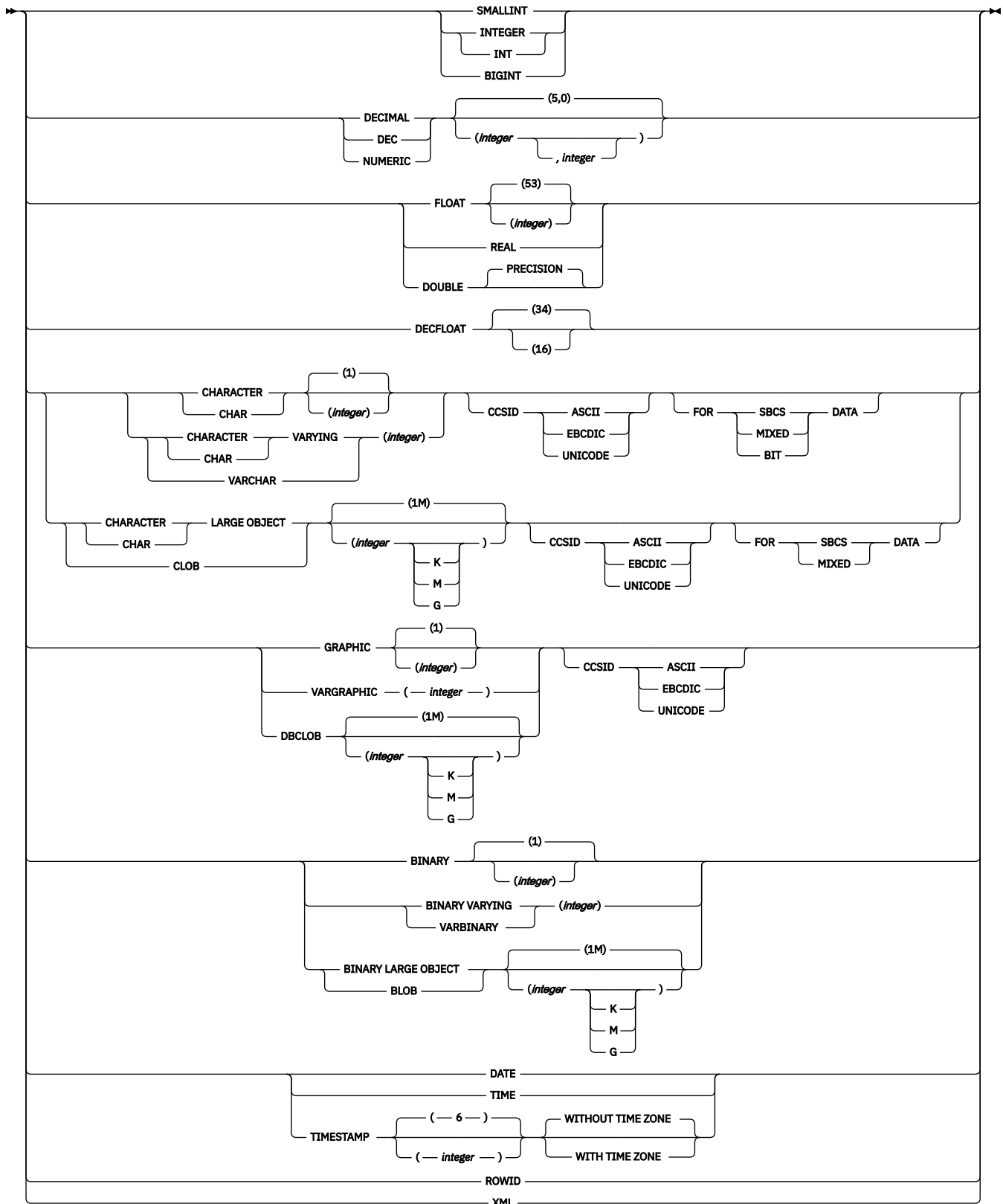

option-list:

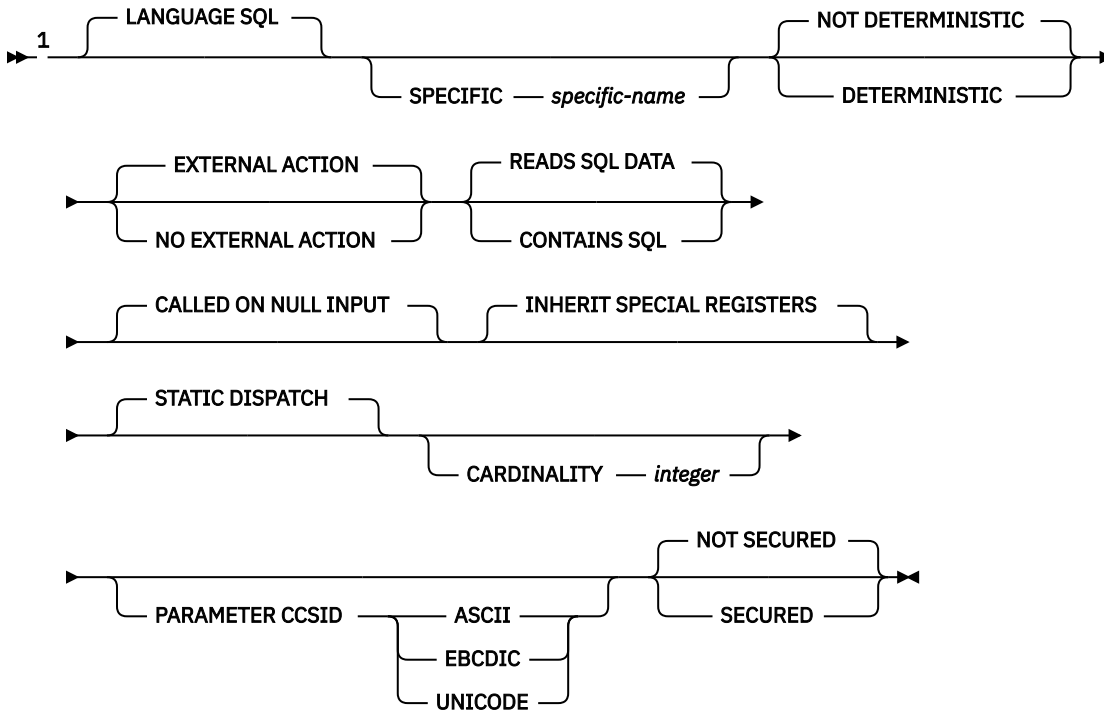

Notes:

¹ The options in the *option-list* can be specified in any order. However, the same clause cannot be specified more than one time.

function-definition

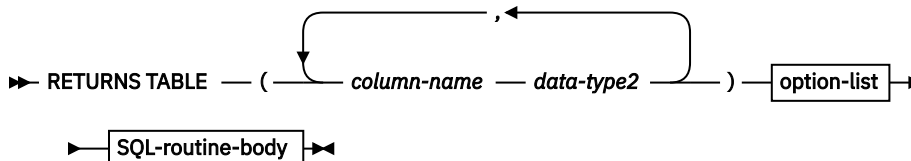

SQL-routine-body:



Description for CREATE FUNCTION (SQL table)

function-name

Names the user-defined function. The name is implicitly or explicitly qualified by a schema name. The combination of the name, the schema name, the number of parameters, and the data type of each parameter (without regard to any length, precision, scale, subtype, or encoding scheme attribute of the data type) must not identify a user-defined function that exists at the current server. For more information, see "Choosing the schema and function names" and "Determining the uniqueness of functions in a schema" in "CREATE FUNCTION statement (overview)" on page 1424.

(parameter-declaration,...)

Identifies the number of input parameters of the function, and specifies the name and data type of each parameter. All of the parameters for a function are input parameters and are nullable. There must be one entry in the list for each parameter that the function expects to receive.

parameter-name

Specifies the name of the input parameter. Each name in the parameter list must not be the same as any other name.

data-type1

Specifies the data type of the input parameter. The data type can be a built-in data type or a distinct type.

built-in-type

The data type of the parameter is a built-in data type.

For more information on the data types, including the subtype of character data types (the FOR subtype DATA clause), see [built-in types](#). However, the varying length string data types have different maximum lengths for this statement than for the CREATE TABLE statement. The maximum lengths for parameters (and SQL variables) are as follows:

- VARCHAR or VARBINARY: 32704
- VARGRAPHIC: 16352

For parameters with a character or graphic data type, the PARAMETER CCSID clause or the CCSID clause indicates the encoding scheme of the parameter. If you do not specify either of the CCSID clauses, the encoding scheme is the value of the DEF ENCODING SCHEME field on installation panel DSNTIPF.

Although an input parameter with a character data type has an implicitly or explicitly specified subtype (BIT, SBCS, or MIXED), the value that is actually passed in the input parameter can have any subtype. Therefore, conversion of the input data to the subtype of the parameter might occur when the function is invoked. With ASCII or EBCDIC, an error occurs if mixed data that actually contains DBCS characters is used as the value for an input parameter that is declared with an SBCS subtype.

distinct-type-name

The data type of the parameter is a distinct type. Any length, precision, scale, subtype, or encoding scheme attributes for the parameter are those of the source type for the distinct type.

TABLE LIKE *table-name* AS LOCATOR

Specifies that the parameter is a transition table. However, when the function is invoked, the actual values in the transition table are not passed to the function. A single value is passed instead. This value is a locator for the table, which the function uses to access the columns of the transition table. The table that is identified can contain XML columns; however, the function cannot reference those XML columns.

A function with a table parameter can only be invoked from the triggered action of a trigger.

RETURNS TABLE

Specifies that the output of the function is a table. The RETURN statement in an SQL table function must return a table result. The parentheses that follow the RETURNS TABLE keyword delimit a list of name and data type pairs of the columns of the output table. All columns of the output table are nullable.

column-name

Specifies the name of the column. The name cannot be qualified, and must be unique within the RETURNS TABLE clause for the function.

data-type2

Specifies the data type and attributes of the column of the output table.

For SQL table functions, the result table of the function might include multiple encoding schemes – similar to what a view definition can include.

LANGUAGE SQL

Specifies that the function is written exclusively in SQL.

SPECIFIC *specific-name*

Specifies a unique name for the function.

NOT DETERMINISTIC or DETERMINISTIC

Specifies whether the function returns the same results each time that the function is invoked with the same input arguments. Db2 does not verify that the function program is consistent with the specification of NOT DETERMINISTIC or DETERMINISTIC.

NOT DETERMINISTIC

Specifies that the function might not return the same result table each time that the function is invoked with the same input arguments, even when the referenced data in the database has not changed. The function depends on some state values that might affect the results. When the MATERIALIZE_NODET_SQLTUDF subsystem parameter is set to YES, Db2 disables the merging of SQL table functions that are defined with this option. An example of a table function that is not deterministic is one which references special registers, other functions that are not deterministic, or a sequence in a way that affects the table function's result table. NOT DETERMINISTIC is the default.

DETERMINISTIC

Specifies that the function always returns the same result table each time that the function is invoked with the same input arguments (provided that the referenced data in the database has not changed). Db2 enables the merging of SQL table functions that are defined with this option.

EXTERNAL ACTION or NO EXTERNAL ACTION

Specifies whether the function contains an external action. Db2 does not verify that the function program is consistent with the specification of EXTERNAL ACTION or NO EXTERNAL ACTION.

EXTERNAL ACTION

The function performs some external action (outside the scope of the function program). Thus, the function must be invoked with each successive function invocation. EXTERNAL ACTION must be specified if the function invokes another function that has external actions. EXTERNAL ACTION is the default.

NO EXTERNAL ACTION

The function does not perform any external action. It need not be called with each successive function invocation. Functions that are defined with NO EXTERNAL ACTION might perform better than functions that are defined with EXTERNAL ACTION because the function might not be invoked for each successive function invocation.

Although the scope of global variables are beyond the scope of the routine, global variables can be set in the routine body when NO EXTERNAL ACTION is specified.

READS SQL DATA or CONTAINS SQL

Specifies the classification of SQL statements and nested routines that this routine can execute or invoke. The database manager verifies that the SQL statements issued by the function, and all routines locally invoked by the routine, are consistent with this specification; the verification is not performed when nested remote routines are invoked. For the classification of each statement, see Appendix D, “SQL statement data access classification for routines,” on page 2275.

READS SQL DATA

Specifies that the function can execute statements with a data access indication of READS SQL DATA or CONTAINS SQL. The function cannot execute SQL statements that modify data.

READS SQL DATA is the default.

CONTAINS SQL

Specifies that the function can execute only SQL statements with a data access indication of CONTAINS SQL. The function cannot execute statements that read or modify data.

CALLED ON NULL INPUT

Specifies that the function is called regardless of whether any of the input arguments are null, making the function responsible for testing for null argument values. The function can return an empty table, depending on its logic.

CALLED ON NULL INPUT is the default.

INHERIT SPECIAL REGISTERS

Specifies that existing values of special registers are inherited upon entry to the function. **INHERIT SPECIAL REGISTERS** is the default.

STATIC DISPATCH

At function resolution time, Db2 chooses a function based on the static (or declared) types of the function parameters. **STATIC DISPATCH** is the default.

CARDINALITY integer

Specifies an estimate of the expected number of rows that the function returns. The number is used for optimization purposes. The value of *integer* must be between 0 and 2147483647.

If you do not specify **CARDINALITY**, Db2 assumes a finite value. The finite value is the same value that Db2 assumes for tables for which the **RUNSTATS** utility has not gathered statistics.

If a function has an infinite cardinality (the function never returns the end-of-table condition and always returns a row), a query that requires the end-of-table condition to work correctly will need to be interrupted.

PARAMETER CCSID

Specifies the encoding scheme for character and graphic string parameters is ASCII, EBCDIC, or UNICODE. The default encoding scheme is the value that is specified in the **CCSID** clauses of the parameter list or **RETURNS** clause, or in the **DEF ENCODING SCHEME** field on installation panel **DSNTIPF**. This clause provides a convenient way to specify the encoding scheme for character and graphic string parameters. If individual **CCSID** clauses are specified for individual parameters in addition to this **PARAMETER CCSID** clause, the value specified in all of the **CCSID** clauses must be the same value that is specified in this clause. This clause also specifies the encoding scheme that is used for system-generated parameters of the routine such as message tokens and **DBINFO**.

NOT SECURED or SECURED

Specifies if the function is considered secure for row access control and column access control. The **SECURED** or **NOT SECURED** option applies to all future versions of the function.

NOT SECURED

Specifies that the function is not considered secure for row access control and column access control.

NOT SECURED is the default.

When the function is invoked, the arguments of the function must not reference a column for which a column mask is enabled when the table is using active column access control.

SECURED

Specifies that the function is considered secure for row access control and column access control.

The function must be secure when it is referenced in a row permission or a column mask.

SQL-routine-body

RETURN-statement

Specifies the return value of the function. A **RETURN** statement must be specified for an SQL table function.

WRAPPED obfuscated-statement-text

Specifies the encoded definition of the function. A **CREATE FUNCTION** statement can be encoded using the **WRAP** scalar function.

WRAPPED must not be specified on a static **CREATE** statement.

ATOMIC

ATOMIC indicates that an unhandled exception condition within the **RETURN** statement causes the statement to be rolled back.

Notes for CREATE FUNCTION (SQL table)

Considerations for all types of user-defined functions:

For considerations that apply to all types of user-defined functions, see [“CREATE FUNCTION statement \(overview\)”](#) on page 1424.

Self-referencing function:

The body of an SQL function (that is, the *expression* or NULL in the RETURN statement in the body of the CREATE FUNCTION statement) cannot contain a recursive invocation of itself or to another function that invokes it, because such a function would not exist to be referenced.

Dependent objects:

An SQL routine is dependent on objects that are referenced in the routine body.

Obfuscated statements:

A CREATE FUNCTION statement can be executed in obfuscated form. In an obfuscated statement, only the function name, parameters, and the WRAPPED keyword are readable. The rest of the statement is encoded in such a way that it is not readable but can be decoded by a database server that supports obfuscated statements. The WRAP scalar function produces obfuscated statements. Any debug options that are specified when the function is created from an obfuscated statement are ignored.

Resolution of object names:

Db2 resolves object names inside the body of the function according to the rules in [“Unqualified object name resolution”](#) on page 86 and the type of the object. The name resolution occurs when the function is created.

Referencing date and time special registers:

If an SQL function contains multiple references to any of the date or time special registers, all references return the same value. In addition, this value is the same value that is returned by the retrieving value of the special register in the statement that invoked the function.

Considerations for columns that are defined with a field procedure:

The body of an SQL table function must not reference a column that is defined with a field procedure, and the RETURNS clause of an SQL table function must not reference a column that is defined with a field procedure. An SQL table function must not be invoked with an expression that is derived from a column that is defined with a field procedure.

Restrictions involving pending definition changes:

The body of an SQL table function must not reference a table that has pending definition changes.

Alternative syntax and synonyms:

To provide compatibility with previously releases of Db2 or other products in the Db2 family, Db2 supports the following alternative syntax:

- VARIANT as a synonym for NOT DETERMINISTIC
- NOT VARIANT as a synonym for DETERMINISTIC
- NULL CALL as a synonym for CALLED ON NULL INPUT

Examples for CREATE FUNCTION (SQL table)

Example 1

Define a table function, JTABLE, to return a table with 3 columns:

```
CREATE FUNCTION JTABLE (COLD_VALUE CHAR(9), T2_FLAG CHAR(1))
  RETURNS TABLE (COLA INT, COLB INT, COLC INT)
  LANGUAGE SQL
  SPECIFIC DEPTINFO
  NOT DETERMINISTIC
  READS SQL DATA
  RETURN
  SELECT A.COLA, B.COLB, B.COLC
  FROM TABLE1 AS A
  LEFT OUTER JOIN
```

```
TABLE2 AS B
ON A.COL1 = B.COL1 AND T2_FLAG = 'Y'
WHERE A.COLD = COLD_VALUE;
```

Example 2

Define a table function that returns the employees in a specified department number. The function simply returns the employees for the requested department:

```
CREATE FUNCTION DEPTEMPLOYEES (DEPTNO CHAR(3))
RETURNS TABLE (EMPNO CHAR(6), LASTNAME VARCHAR(15), FIRSTNAME VARCHAR(12))
LANGUAGE SQL
READS SQL DATA
NO EXTERNAL ACTION
DETERMINISTIC
RETURN
  SELECT EMPNO, LASTNAME, FIRSTNAME
  FROM YEMP
  WHERE YEMP.WORKDEPT = DEPTEMPLOYEES.DEPTNO;
```

Related concepts

[SQL table functions \(Db2 Application programming and SQL\)](#)

[Naming conventions](#)

The rules for forming a name depend on the type of the object designated by the name.

Related tasks

[Creating a user-defined function \(Db2 Application programming and SQL\)](#)

CREATE GLOBAL TEMPORARY TABLE statement

The CREATE GLOBAL TEMPORARY TABLE statement creates a description of a temporary table at the current server.

Invocation for CREATE GLOBAL TEMPORARY TABLE

This statement can be embedded in an application program or issued interactively. It is an executable statement that can be dynamically prepared.

Authorization for CREATE GLOBAL TEMPORARY TABLE

The privilege set that is defined below must include at least one of the following:

- The CREATETMTAB system privilege
- The CREATETAB database privilege for any database
- DBADM, DBCTRL, or DBMAINT authority for any database
- SYSADM or SYSCTRL authority
- System DBADM
- Installation SYSOPR authority (when the current SQLID of the process is set to SYSINSTL)

However, DBADM, DBCTRL, or DBMAINT authority is not sufficient authority if you are creating a temporary table for someone else and the table qualifier is not your authorization ID.

Additional privileges might be required when the data type of a column is a distinct type or the LIKE clause is specified. See the description of *distinct-type* and LIKE for the details.

Privilege set: The privilege set is the same as the privilege set for the CREATE TABLE statement. See information about CREATE TABLE [Authorization](#) for details.

Syntax for CREATE GLOBAL TEMPORARY TABLE

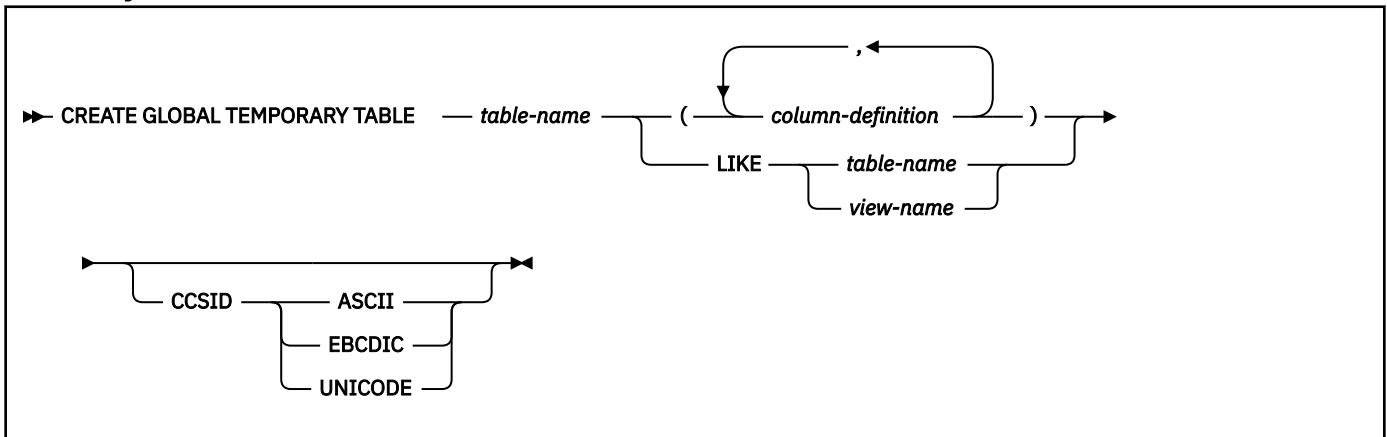

column-definition:

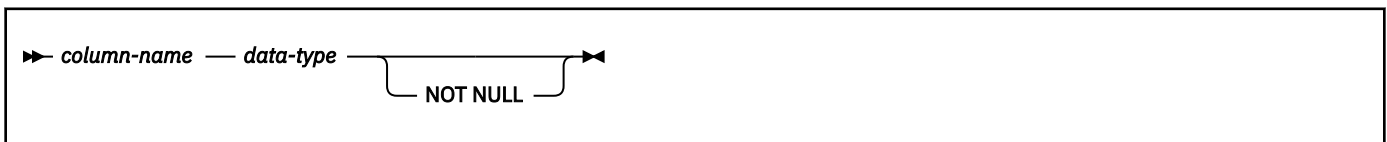

data-type:



built-in-type:

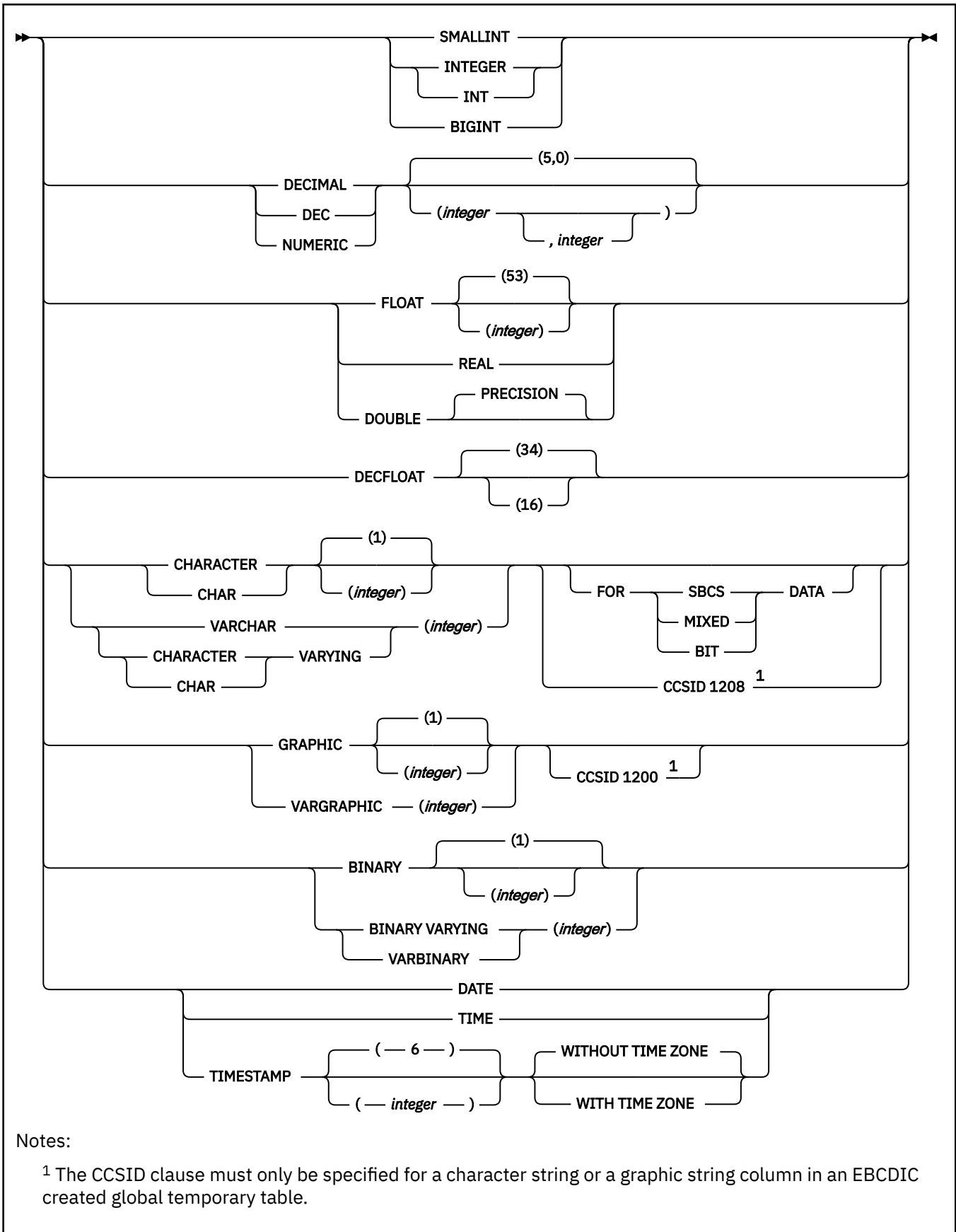

Notes:

¹ The CCSID clause must only be specified for a character string or a graphic string column in an EBCDIC created global temporary table.

Description for CREATE GLOBAL TEMPORARY TABLE

table-name

Names the temporary table. The name, including the implicit or explicit qualifier, must not identify a table, view, alias, synonym, or temporary table that exists at the database server, or a table that exists in the SYSIBM.SYSPENDINGOBJECTS catalog table.

The qualification rules for a temporary table are the same as for other tables.

The owner acquires ALL PRIVILEGES on the table WITH GRANT OPTION and the authority to drop the table.

For more information, see [Guidelines for table names \(Db2 Administration Guide\)](#).

column-definition

Defines the attributes of a column for each instance of the table. The number of columns defined must not exceed 750. The maximum record size must not exceed 32714 bytes. The maximum row size must not exceed 32706 bytes (8 bytes less than the maximum record size).

column-name

Names the column. The name must not be qualified and must not be the same as the name of another column in the table.

data-type

Specifies the data type of the column. The data type can be a built-in data type or a distinct type.

built-in-type

The data type of the column is a built-in data type.

For more information on and the rules that apply to the data types, see [built-in-type](#).

distinct-type

Any distinct type except one that is based on a LOB or ROWID data type. The privilege set must implicitly or explicitly include the USAGE privilege on the distinct type.

NOT NULL

Specifies that the column cannot contain nulls. Omission of NOT NULL indicates that the column can contain nulls.

LIKE *table-name* or *view-name*

Specifies that the columns of the table have exactly the same name and description as the columns of the identified table or view. The name specified after LIKE must identify a table, view, or temporary table that exists at the current server. The identified table must not be an accelerator-only table. A view cannot contain columns of length 0.

The privilege set must implicitly or explicitly include the SELECT privilege on the identified table or view.

This clause is similar to the LIKE clause on CREATE TABLE, but it has the following differences:

- If any column of the identified table or view has an attribute value that is not allowed for a column in a temporary table, that attribute value is ignored. The corresponding column in the new temporary table has the default value for that attribute unless otherwise indicated.
- If any column of the identified table or view allows a default value other than null, that default value is ignored and the corresponding column in the new temporary table has no default value. A default value other than null is not allowed for any column in a temporary table.

CCSID *encoding-scheme*

Specifies the encoding scheme for string data stored in the table.

ASCII

Specifies that the data must be encoded by using the ASCII CCSIDs of the server.

An error occurs if a valid ASCII CCSID has not been specified for the installation.

EBCDIC

Specifies that data must be encoded by using the EBCDIC CCSIDs of the server.

An error occurs if a valid EBCDIC CCSID has not been specified for the installation.

UNICODE

Specifies that data must be encoded by using the CCSIDs of the server for Unicode.

An error occurs if a valid CCSID for Unicode has not been specified for the installation.

Usually, each encoding scheme requires only a single CCSID. Additional CCSIDs are needed when mixed, graphic, or Unicode data is used. An error occurs if CCSIDs have not been defined.

The CCSID clause can be specified for the created temporary table, or for individual columns in the created temporary table. If a CCSID clause is specified for the table, that CCSID specifies the encoding scheme for the table, regardless of whether the LIKE clause is also specified. If a CCSID clause is not specified for the table, the encoding scheme for the table is EBCDIC.

If a CCSID clause is specified for a column, the encoding scheme for the created temporary table must be EBCDIC. If a CCSID clause is not specified for a column, and the LIKE clause is not specified for the table, the CCSID of the column is the same as the CCSID of the table. If the LIKE clause is specified, and the source table that is specified in the LIKE clause is an EBCDIC table with Unicode columns, the columns in the created temporary table that correspond to the Unicode columns in the source table are also Unicode.

Notes for CREATE GLOBAL TEMPORARY TABLE

Owner privileges

The owner of the table has all table privileges (see [“GRANT statement \(table or view privileges\)”](#) on page 1988) with the ability to grant these privileges to others. For more information about ownership of the object, see [“Authorization, privileges, permissions, masks, and object ownership”](#) on page 90.

Instantiation and termination

Let T be a temporary table defined at the current server and let P denote an application process:

- An empty instance of T is created as a result of the first implicit or explicit reference to T in an OPEN, SELECT INTO or SQL data change operation that is executed by any program in P.
- Any program in P can reference T and any reference to T by a program in P is a reference to that instance of T.

When a commit operation terminates a unit of work in P and no program in P has an open WITH HOLD cursor that is dependent on T, the commit includes the operation DELETE FROM T.

- When a rollback operation terminates a unit of work in P, the rollback includes the operation DELETE FROM T.
- When the connection to the database server at which an instance of T was created terminates, the instance of T is destroyed. However, the definition of T remains. A DROP TABLE statement must be executed to drop the definition of T.

Restrictions and extensions

Let T denote a temporary table:

- Columns of T cannot have default values other than null.
- A column of T cannot have a LOB or ROWID data type (or a distinct type based on one).
- T cannot have unique constraints, referential constraints, or check constraints.
- T cannot be defined as the parent in a referential constraint.
- T cannot be referenced in:
 - A CREATE INDEX statement.
 - A LOCK TABLE statement.
 - As the object of an UPDATE statement in which the object is T or a view of T. However, you can reference T in the WHERE clause of an UPDATE statement (including the update operation of the MERGE statement).

– Db2 utility commands.

- If T is referenced in the *fullselect* of a CREATE VIEW statement, you cannot specify a WITH CHECK OPTION clause in the CREATE VIEW statement.
- ALTER TABLE T is valid only if the statement is used to add a column to T. Any column that you add to T must have a default value of null.

When you alter T, any packages that refer to the table are invalidated, and Db2 automatically rebinds the packages the next time they are run.

- DELETE FROM T or a *view of T* is valid only if the statement does not include a WHERE or WHERE CURRENT OF clause. In addition, DELETE FROM *view of T* is valid only if the view was created (CREATE VIEW) without the WHERE clause. A DELETE FROM statement deletes all the rows from the table or view.
- You can refer to T in the FROM clause of any subselect. If you refer to T in the first FROM clause of a *select-statement*, you cannot specify a FOR UPDATE clause.
- You cannot use a DROP DATABASE statement to implicitly drop T. To drop T, reference T in a DROP TABLE statement.
- A temporary table instantiated by an SQL statement using a three-part table name can be accessed by another SQL statement using the same name in the same application process for as long as the Db2 connection which established the instantiation is not terminated.
- GRANT ALL PRIVILEGES ON T is valid, but you cannot grant specific privileges on T.

Of the ALL privileges, only the ALTER, INSERT, DELETE, and SELECT privileges can actually be used on T.

- REVOKE ALL PRIVILEGES ON T is valid, but you cannot revoke specific privileges from T.
- A COMMIT operation deletes all rows of every temporary table of the application process, but the rows of T are not deleted if any program in the application process has an open WITH HOLD cursor that is dependent on T. In addition, if RELEASE(COMMIT) is in effect and no open WITH HOLD cursors are dependent on T, all logical work files for T are also deleted.
- A ROLLBACK operation deletes all rows and all logical work files of every temporary table of the application process.
- You can reuse threads when using a temporary table, and a logical work file for a temporary table name remains available until deallocation. A new logical work file is not allocated for that temporary table name when the thread is reused.
- You can refer to T in the following statements:

Statement	Statement	Statement
ALTER FUNCTION	CREATE PROCEDURE	DECLARE TABLE
ALTER PROCEDURE	CREATE SYNONYM	DELETE (if it does not include a WHERE clause)
COMMENT	CREATE TABLE LIKE	DROP TABLE
CREATE ALIAS	CREATE VIEW	INSERT
CREATE FUNCTION	DESCRIBE TABLE	LABEL
		SELECT INTO

Alternative syntax and synonyms: For compatibility with previous releases of Db2, you can specify LONG VARCHAR as a synonym for VARCHAR(*integer*) and LONG VARGRAPHIC as a synonym for VARGRAPHIC(*integer*) when defining the data type of a column. However, the use of these synonyms is not encouraged because after the statement is processed, Db2 considers a LONG VARCHAR column to be VARCHAR and a LONG VARGRAPHIC column to be VARGRAPHIC.

Examples for CREATE GLOBAL TEMPORARY TABLE

Example 1: Create a temporary table, CURRENTMAP. Name two columns, CODE and MEANING, both of which cannot contain nulls. CODE contains numeric data and MEANING has character data. Assuming a value of NO for the field MIXED DATA on installation panel DSNTIPF, column MEANING has a subtype of SBCS:

```
CREATE GLOBAL TEMPORARY TABLE CURRENTMAP
(CODE INTEGER NOT NULL, MEANING VARCHAR(254) NOT NULL);
```

Example 2: Create a temporary table, EMP:

```
CREATE GLOBAL TEMPORARY TABLE EMP
(TMPDEPTNO CHAR(3) NOT NULL,
TMPDEPTNAME VARCHAR(36) NOT NULL,
TMPMGRNO CHAR(6)
TMPLOCATION CHAR(16) );
```

CREATE INDEX statement

The CREATE INDEX statement creates a partitioning index or a secondary index and an index space at the current server. The columns included in the key of the index are columns of a table at the current server.

Invocation for CREATE INDEX

This statement can be embedded in an application program or issued interactively. It is an executable statement that can be dynamically prepared only if DYNAMICRULES RUN behavior is in effect. For more information, see [“Authorization IDs and dynamic SQL” on page 94](#).

Authorization for CREATE INDEX

The privilege set that is defined below must include at least one of the following:

- The INDEX privilege on the table
- Ownership of the table
- DBADM authority for the database that contains the table
- SYSADM or SYSCTRL authority
- System DBADM
- Installation SYSOPR authority (when the current SQLID of the process is set to SYSINSTL)

If the database is implicitly created, the database privileges must be on the implicit database or on DSNCB04.

If the index is created using an expression, the EXECUTE privilege is required on any user-defined function that is invoked in the index expression.

Additional privileges might be required, as explained in the description of the BUFFERPOOL and USING STOGROUP clauses.

Privilege set: If the statement is embedded in an application program, the privilege set is the privileges that are held by the owner of the plan or package. If the specified index name includes a qualifier that is not the same as this owner, the privilege set must include SYSADM or SYSCTRL authority, or DBADM or DBCTRL authority for the database.

If ROLE AS OBJECT OWNER is in effect, the schema qualifier must be the same as the role, unless the role has the CREATEIN privilege on the schema, SYSADM authority, or SYSCTRL authority.

If ROLE AS OBJECT OWNER is not in effect, one of the following rules applies:

- If the privilege set lacks the CREATIN privilege on the schema, SYSADM authority, or SYSCTRL authority, the schema qualifier (implicit or explicit) must be the same as one of the authorization ids of the process.

- If the privilege set includes SYSADM authority or SYSCTRL authority, the schema qualifier can be any valid schema name.

If the statement is dynamically prepared, the privilege set is the privileges that are held by the SQL authorization ID of the process unless the process is within a trusted context and the ROLE AS OBJECT OWNER clause is specified. In that case, the privilege set is the set of privileges that are held by the role that is associated with the primary authorization ID of the process. However, if the specified index name includes a qualifier that is not the same as this authorization ID, the following rules apply:

- If the privilege set includes SYSADM or SYSCTRL authority (or DBADM authority for the database, or DBCTRL authority for the database when creating a table), the schema qualifier can be any valid schema name.
- If the privilege set lacks SYSADM or SYSCTRL authority (or DBADM authority for the database, or DBCTRL authority for the database when creating a table), the schema qualifier is valid only if it is the same as one of the authorization IDs of the process and the privilege set that are held by that authorization ID includes all privileges needed to create the index. This is an exception to the rule that the privilege set is the privileges that are held by the SQL authorization ID of the process.

Syntax for CREATE INDEX

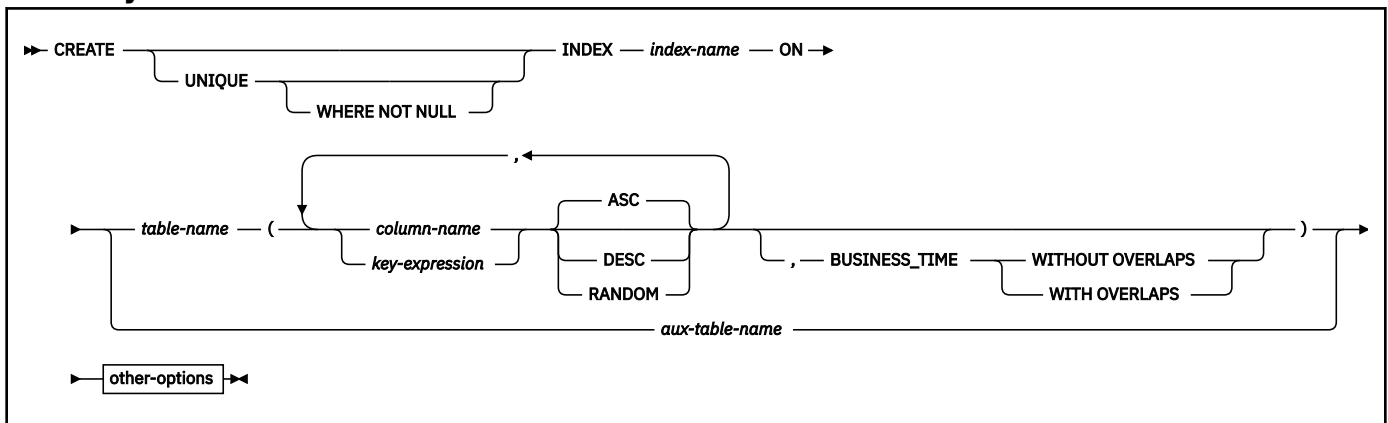

other-options:

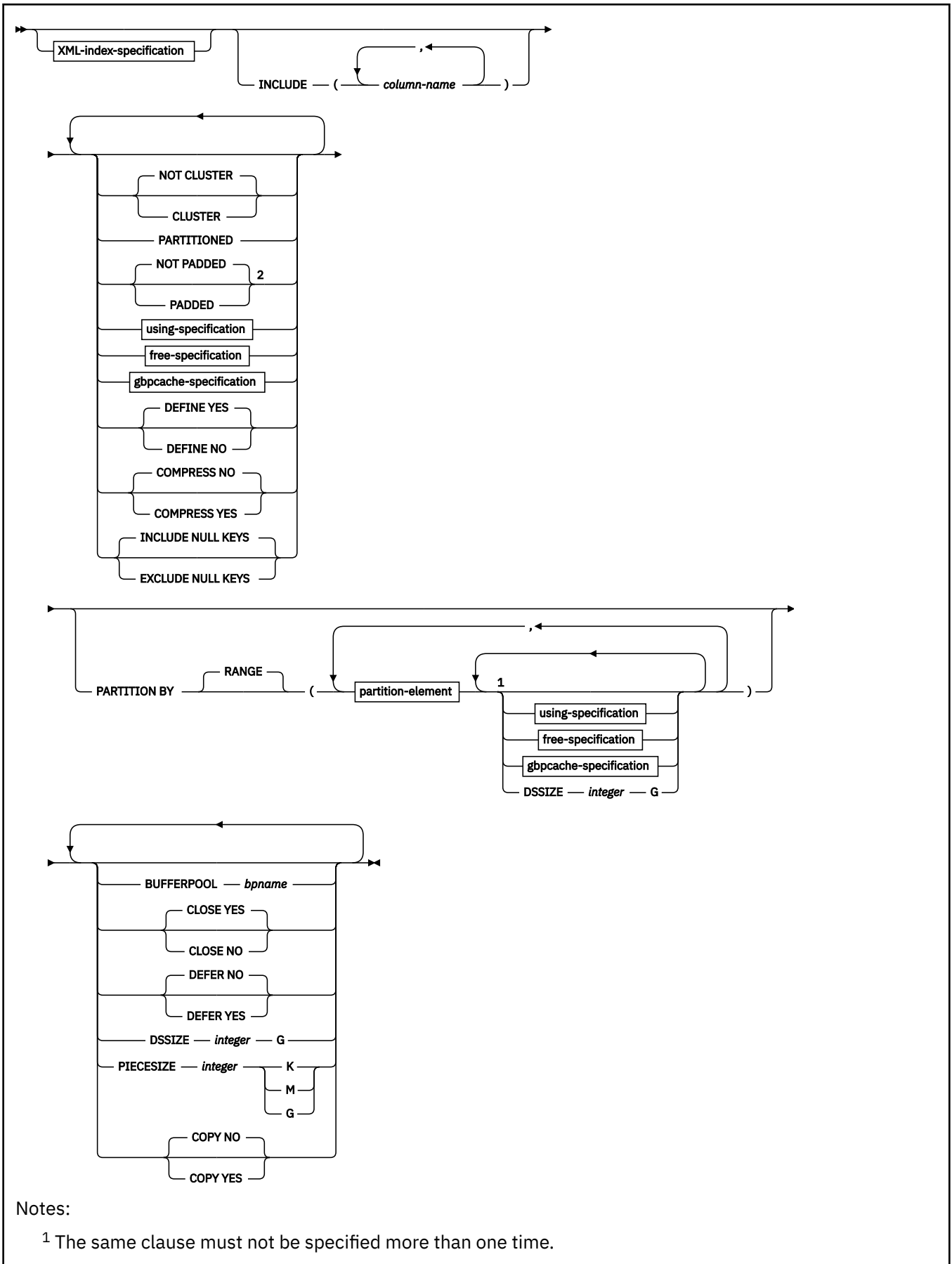

Notes:

¹ The same clause must not be specified more than one time.

² The value of field PAD INDEXES BY DEFAULT (on installation panel DSNTIPE) determines the default. When the value is NO, NOT PADDED is the default. When the value is YES, PADDED is the default. For more information, see the description of the PADDED or NOT PADDED options.

XML-index-specification:

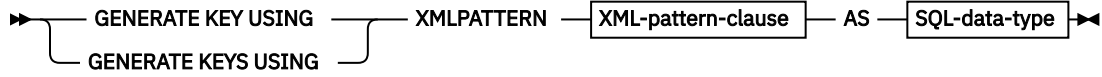

XML-pattern-clause:

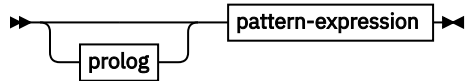

prolog:

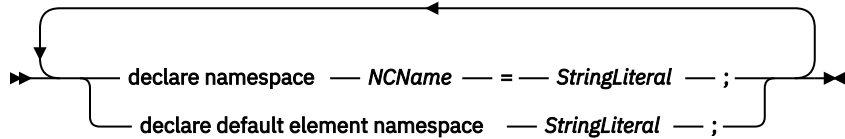

pattern-expression:

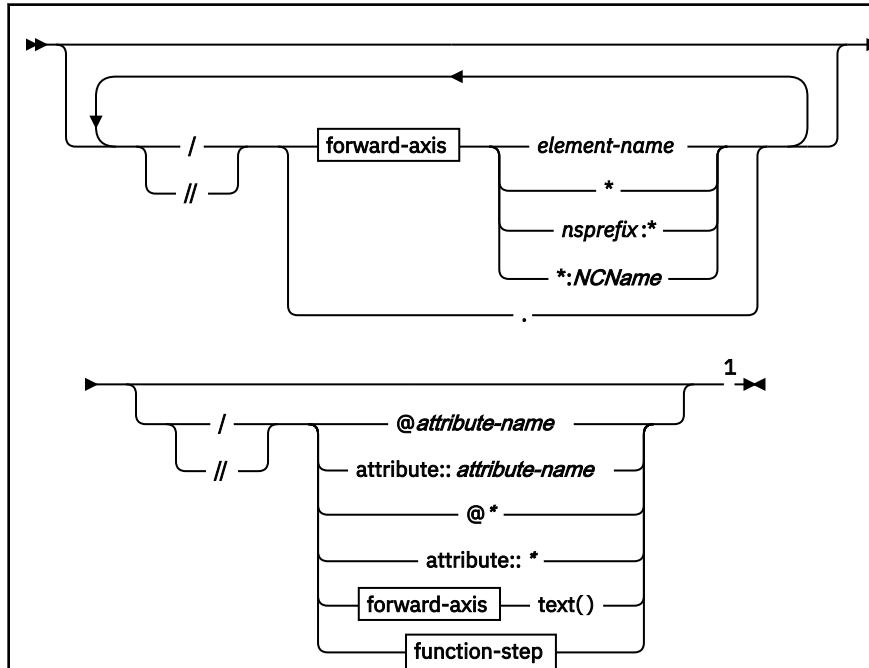

Notes:

¹ *pattern-expression* cannot be an empty string.

forward-axis:



function-step:

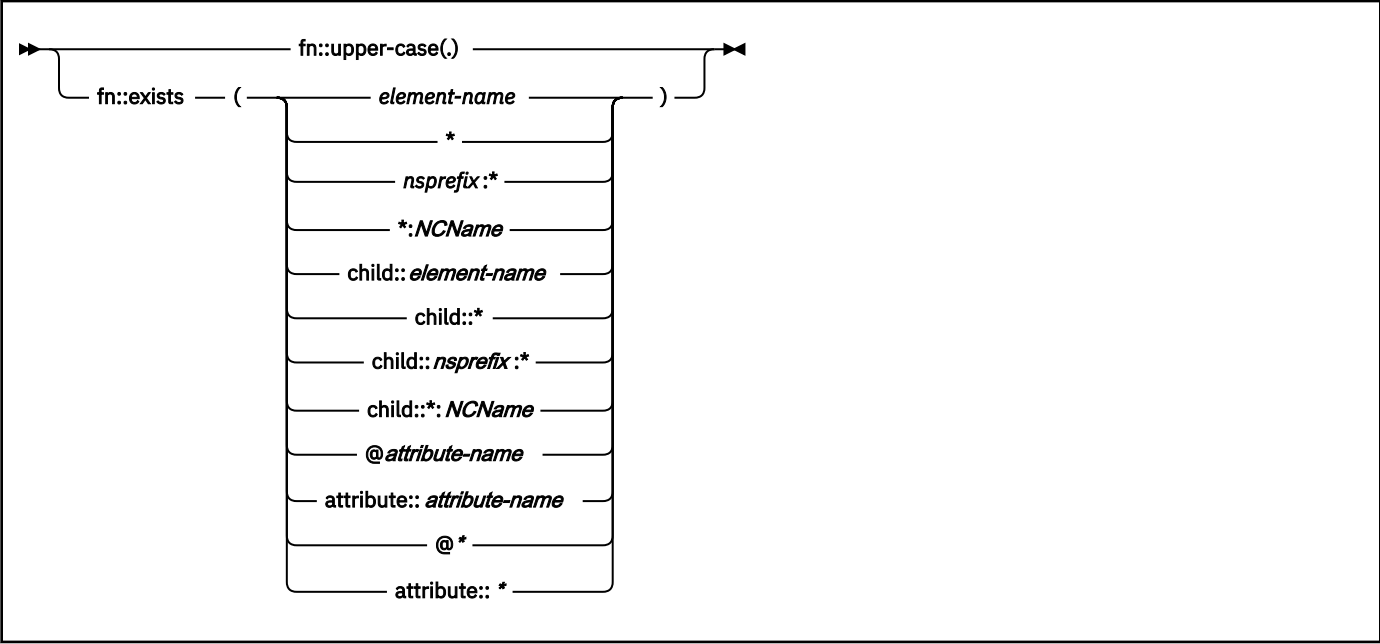

SQL-data-type:

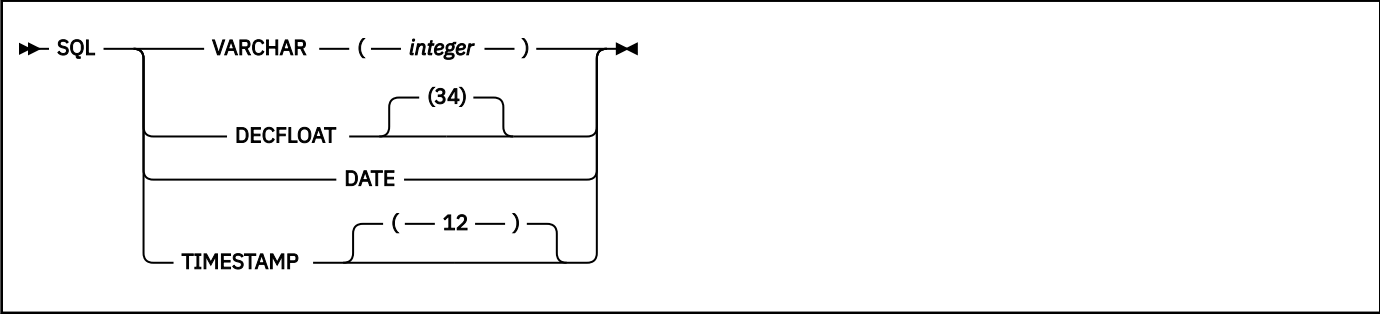

using-specification:

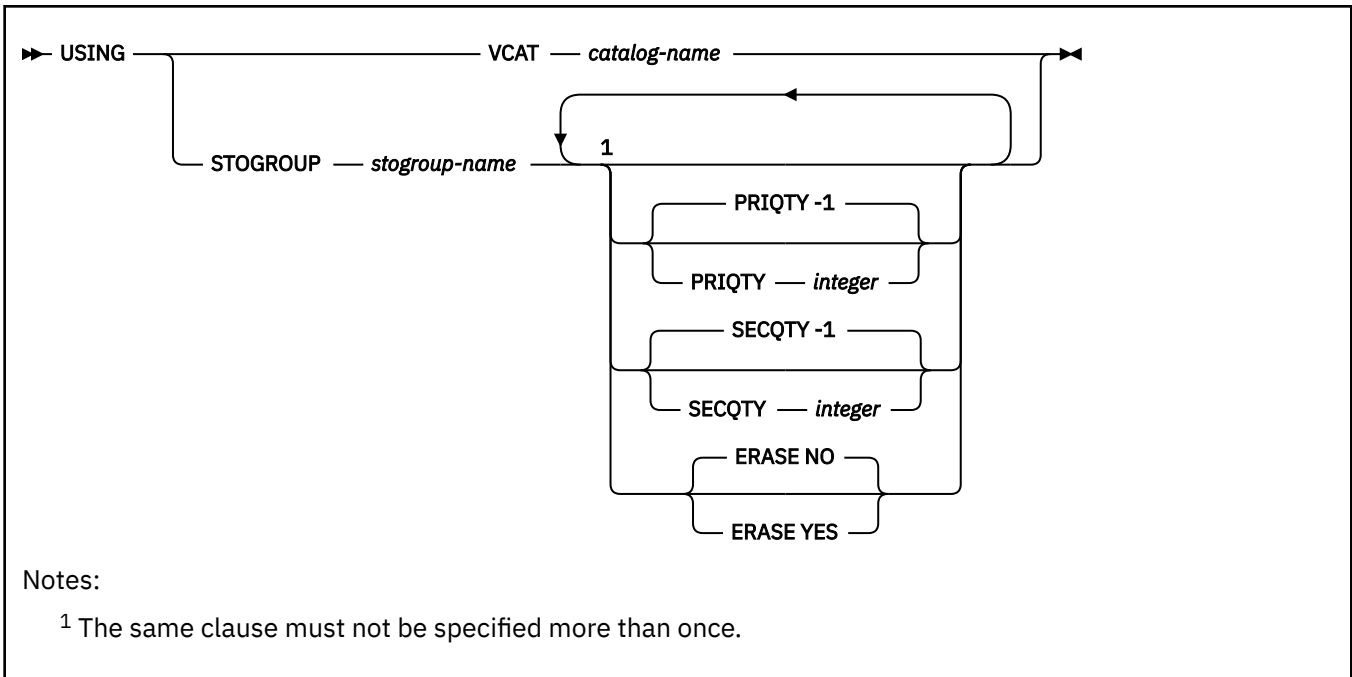

free-specification:

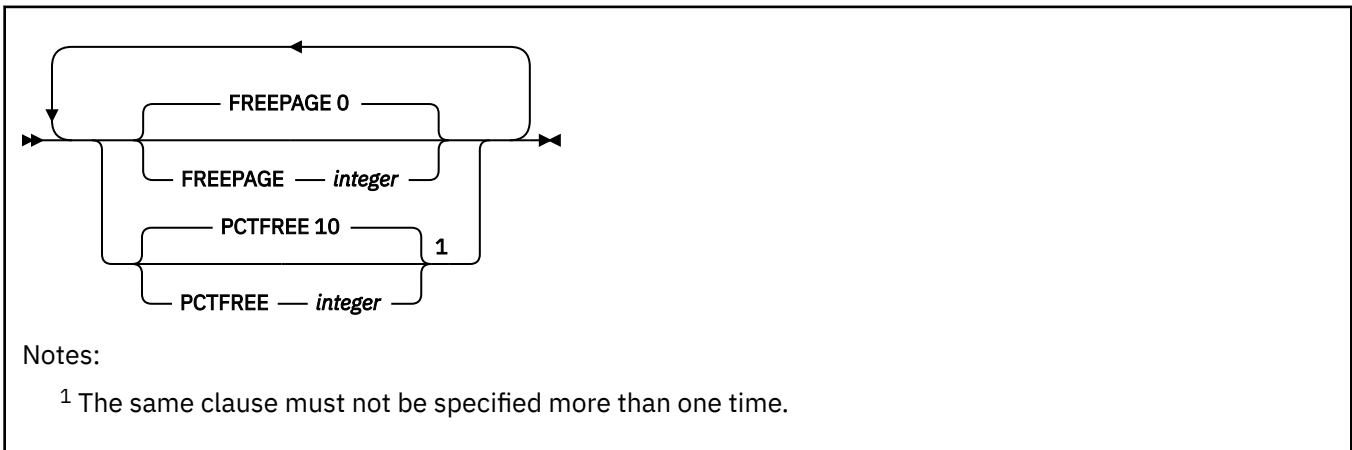

gbpcache-specification:



partition-element:

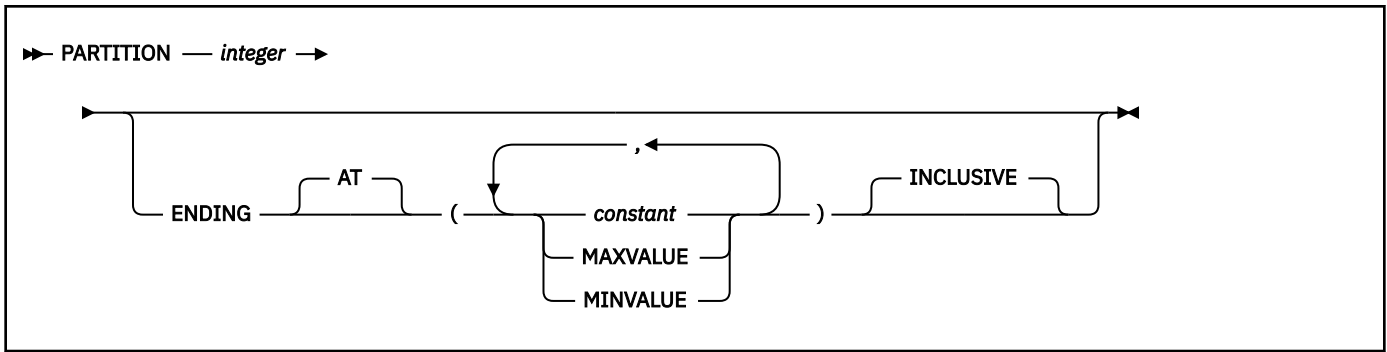

Description for CREATE INDEX

UNIQUE

Prevents the table from containing two or more rows with the same value of the index key. When UNIQUE is used, all null values for a column are considered equal. For example, if the key is a single column that can contain null values, that column can contain only one null value. The constraint is enforced when rows of the table are updated or new rows are inserted.

The constraint is also checked during the execution of the CREATE INDEX statement. If the table already contains rows with duplicate key values, the index is not created.

UNIQUE WHERE NOT NULL

Prevents the table from containing two or more rows with the same value of the index key where all null values for a column are not considered equal. Multiple null values are allowed. Otherwise, this is identical to UNIQUE.

INDEX *index-name*

Names the index. The name must not identify an index that exists at the current server, or is listed in the SYSIBM.SYSPENDINGOBJECTS catalog table, or is in an accelerator-only table.

The associated index space also has a name. That name appears as a qualifier in the names of data sets defined for the index. If the data sets are managed by the user, the name is the same as the second (or only) part of *index-name*. If this identifier consists of more than eight characters, only the first eight are used. The name of the index space must be unique among the names of the index spaces and table spaces of the database for the identified table. If the data sets are defined by Db2, Db2 derives a unique name.

If the index is an index on a declared temporary table, the qualifier, if explicitly specified, must be SESSION. If the index name is unqualified, Db2 uses SESSION as the implicit qualifier.

For more information, see [Index names and guidelines \(Db2 Administration Guide\)](#).

ON *table-name or aux-table-name*

Identifies the table on which the index is created. The name can identify a base table, a materialized query table, a declared temporary table, or an auxiliary table.

table-name

Identifies the base table, materialized query table, or declared temporary table on which the index is created. The name must identify a table that exists at the current server. (The name of a declared temporary table must be qualified with SESSION.)

The name must not identify a clone table. The name must not identify a created temporary table or a table that is implicitly created for an XML column. If the index that is being created is for XML values, the table can contain an XML column, otherwise, the table must not contain an XML column. The name must not identify a catalog table or declared temporary table if the index is created using expressions. The name must not identify an accelerator-only table or a directory table.

If the table has enforced row or column access controls, the row permissions and column masks are not applied during key generation.

column-name,...

Specifies the columns of the index key.

Each *column-name* must identify a column of the table. Do not specify more than 64 columns or the same column more than one time. Do not qualify *column-name*.

Do not specify a column for *column-name* that is defined as follows:

- a LOB column (or a column with a distinct type that is based on a LOB data type)
- a BINARY or VARBINARY column (or a column with a distinct type that is based on a BINARY or VARBINARY data type) when the PARTITION BY RANGE clause is also specified
- a VARBINARY column (or a column with a distinct type that is based on a VARBINARY data type) when the PADDED clause is also specified
- a row change timestamp column when the PARTITION BY RANGE or PARTITIONED clause is also specified.
- a timestamp with time zone column (or a column with a distinct type that is based on the timestamp with time zone data type) when the PARTITION or PARTITION BY RANGE clause is also specified.

A column with an XML type can only be specified if the XMLPATTERN clause is also specified. If the XMLPATTERN clause is specified, only one column can be identified and the column must be an XML type. The resulting index is an XML index.

If the table is an EBCDIC table with Unicode columns, character and graphic columns that are specified for the index key must be all EBCDIC or all Unicode.

The sum of the length attributes of the columns must not be greater than the following limits, where n is the number of columns that can contain null values, m is the number of varying-length columns, and d is the number of DECFLOAT columns in the key:

- $2000 - n$ for a padded, nonpartitioning index
- $2000 - n - 2m - 3d$ for a nonpadded, nonpartitioning index
- $255 - n$ for a partitioning index (padded or nonpadded)
- $255 - n - 2m - 3d$ for a nonpadded, partitioning index

key-expression

Specifies an expression that returns a scalar value. An index with a key that includes one or more expressions consisting of more than just a column name is an *expression-based index*. *key-expression* cannot be specified with the GENERATE KEY USING clause or the INCLUDE clause. *key-expression* has the following restrictions:

- Each *key-expression* must contain at least one reference to a column of *table-name*.

All references to columns of *table-name* must be unqualified. Referenced columns cannot include any FIELDPROCs or a SECURITY LABEL. Referenced columns cannot be implicitly hidden (that is, defined with the IMPLICITLY HIDDEN attribute).

- *key-expression* must not include any of the following:
 - A subquery
 - An aggregate function
 - A function that is not deterministic function
 - A function that has an external action
 - A user-defined function
 - The VERIFY_GROUP_FOR_USER or VERIFY_ROLE_FOR_USER functions
 - A sequence reference
 - A host variable
 - A parameter marker

- A global variable
- A special register
- An expression for which implicit time zone value apply (or example, cast a timestamp to a timestamp with time zone)
- A CASE expression
- An OLAP specification
- If *key-expression* invokes a cast function, the privilege set must implicitly include EXECUTE authority on the generated cast functions for the distinct type.
- If *key-expression* invokes the LOWER or UPPER functions, the input *string-expression* cannot be FOR BIT DATA, and the function invocation must contain the *locale-name* argument.
- If *key-expression* invokes the TRANSLATE function, the function invocation must contain the *to-string* argument.
- *key-expression* must not invoke a built-in function with an argument that references a LOB column, unless the function is SUBSTR or JSON_VAL.
- If *key-expression* invokes the SUBSTR function, an argument to the function that references a LOB column can reference only the inline portion of the LOB column.
- If *key-expression* invokes the JSON_VAL function and the first argument is a LOB column, the column must be defined as an inline LOB.
- If *key-expression* invokes the JSON_VAL function, the function invocation must meet the following conditions:
 - The invocation of the JSON_VAL function must be the outermost expression for *key-expression*.
 - If the first argument is a column, that column must be contained in a table in a partition-by-growth table space.
 - The third argument must end with the string ':na', to indicate that the first argument does not contain a JSON array.
- If *key-expression* invokes the JSON_VAL built-in function, the CREATE INDEX statement must not reference any LOB columns other than the LOB column that is the argument to the JSON_VAL function. Such a CREATE INDEX statement can refer only to a single LOB column.
- The same expression cannot be used more than one time in the same index.
- The data type of the result of the expression cannot be a LOB, XML, DECFLOAT, or array value. However, the data type of an intermediate result can be a LOB or DECFLOAT value (or a distinct type that is based on one of these data types), but not an XML value. For an index with a DECFLOAT intermediate result, the rounding mode that was in effect when the index was created should also be in effect when the index is used.
- If a Unicode column in an EBCDIC table is referenced in a *key-expression*, the encoding scheme of the index keys must either be all Unicode or all EBCDIC. Otherwise, the encoding scheme of the result of a *key-expression* must be the same encoding scheme as the table.

The maximum length of the text string of each *key-expression* is 4000 bytes after conversion to UTF-8. The maximum number of *key-expression* in an extended index is 64.

ASC

Puts the index entries in ascending order by the column. ASC cannot be specified with the GENERATE KEY USING clause.

ASC is the default.

DESC

Puts the index entries in descending order by the column. DESC cannot be specified with the GENERATE KEY USING clause or if the ON clause contains *key-expression*.

RANDOM

Index entries are put in a random order by the column. RANDOM cannot be specified in the following cases:

- A varying length column is part of the index key and the index is defined with the NOT PADDED option
- A column of the index key is defined as TIMESTAMP WITH TIME ZONE or DECFLOAT
- The index is an XML index. An XML index is defined with the GENERATE KEY USING clause
- The index is part of the partitioning key
- The index is an expression-based index

BUSINESS_TIME

Specifies that the columns of the BUSINESS_TIME period are automatically added to the end of the index key in the following order:

- The end column of the BUSINESS_TIME period in ascending order
- The start column of the BUSINESS_TIME period in ascending order

BUSINESS_TIME can be specified as the last item in the list. The list must also include at least one *column-name* or *key-expression*. When BUSINESS_TIME is specified, the columns of the BUSINESS_TIME period must not be specified as *column-name* or a *key-expression*, or as columns in the partitioning key.

WITH OR WITHOUT OVERLAPS

Indicates whether multiple rows may exist with the same values for the non-period columns and expressions of the index key for a row, with overlapping time periods.

WITH OVERLAPS

Indicates that multiple rows may exist with the same values for the non-period columns and expressions of the index key for a row, with overlapping time periods. The BUSINESS_TIME WITH OVERLAPS clause is intended for use in defining an index for the foreign key of a temporal referential constraint.

BUSINESS_TIME WITH OVERLAPS must not be specified when UNIQUE is specified for the index definition.

BUSINESS_TIME WITHOUT OVERLAPS must not be specified if the table is defined with a partitioning key that includes any columns of the BUSINESS_TIME period.

WITHOUT OVERLAPS

Indicates that the values for the non-period columns and expressions of the index key for a row must be unique with respect to the time represented by the BUSINESS_TIME period for the row. Db2 enforces that multiple rows do not exist with the same key values for the columns or expressions of the index, with overlapping time periods. The BUSINESS_TIME WITHOUT OVERLAPS clause is intended for use in defining a unique index to enforce a primary key or unique constraint.

BUSINESS_TIME WITHOUT OVERLAPS can only be specified for an index that is defined as UNIQUE.

aux-table-name

Identifies the auxiliary table on which the index is created. The name must identify an auxiliary table that exists at the current server. If the auxiliary table already has an index, do not create another one. An auxiliary table can only have one index.

Do not specify any columns for the index key. The key value is implicitly defined as a unique 19 byte value that is system generated.

If qualified, *table-name* or *aux-table-name* can be a two-part or three-part name. If a three-part name is used, the first part must match the value of the field Db2 LOCATION NAME of installation panel DSNTIPR at the current server. (If the current server is not the local Db2, this name is not necessarily

the name in the CURRENT SERVER special register.) Whether the name is two-part or three-part, the authorization ID that qualifies the name is the owner of the index.

The table space that contains the named table must be available to Db2 so that its data sets can be opened. If the table space is EA-enabled, the data sets for the index must be defined to belong to a DFSMS data class that has the extended format and addressability attributes.

GENERATE KEY USING

Along with XMLPATTERN, GENERATE KEY USING is required to generate an XML index.

XMLPATTERN

When an XML column is indexed, only parts of the documents will be indexed. To identify those parts, a path expression that follows the XMLPATTERN clause is specified. Only values of those element, attribute, or text nodes which match the specified pattern are indexed. An XML pattern can be specified using an optional namespace declaration where namespace prefixes are mapped to namespace URIs and by providing a path expression. The path expression is similar to a path expression in XQuery except that the paths that are specified for the XML index can support child axis, self-or-descendant axis, wildcard expressions, or attribute only. The maximum length of an XML pattern text is 4000 bytes after being converted to UTF-8. For more information about XQuery, see [Overview of pureXML \(Db2 Programming for XML\)](#).

prolog

To use qualified names in the *pattern-expression*, namespace prefixes need to be declared. A default namespace can also be declared for use with unqualified names.

declare namespace *NCName=StringLiteral*

The namespace prefix, *NCName*, is mapped to a namespace URI that is identified in *StringLiteral*. Multiple namespaces can be declared, but each namespace prefix must be unique within the list of namespace declarations. *NCName* is an XML name as defined by the XML 1.0 standard. *NCName* cannot include a colon character. The namespace URI cannot be `http://www.w3.org/XML/1998/namespace` or `http://w3.org/2000/xmlns/`.

declare default element namespace *StringLiteral*

Specifies the default namespace URI for unqualified names of elements and types. *StringLiteral* is a namespace URI. If no default element namespace is declared, unqualified names of element and types are in no namespace. Only one default namespace can be declared.

pattern-expression

Pattern-expression is used to identify those nodes in an XML document that are indexed. *Pattern-expression* cannot be an empty or invalid string, and the XQuery expression cannot be nested more than 50 levels. *pattern-expression* cannot be an XQuery updating expression.

/ (forward slash)

Separates path expression steps.

// (double forward slash)

Abbreviated syntax for `/descendant-or-self::node()`

.(dot)

Abbreviated syntax for `/self::node()`

child::

Specifies children of the context node. `child::` is the default if no forward axis is specified.

descendant::

Specifies the descendants of the context node.

self::

Specifies the current context node.

descendant-or-self::

Specifies the context node and the descendents of the context node.

element-name

Identifies an element in an XML document. *element-name* is an XML QName that can have one of the following forms:

nsprefix:NCName

nsprefix explicitly specifies a namespace prefix that must be declared.

NCName

An unqualified XML name that uses the default namespace.

*** (an asterisk)**

Indicates any element name. If * is prefixed by *attribute::* or *@*, * indicates any attribute name.

nsprefix:*

Indicates any NCName within the specified namespace.

****:NCName***

Indicates a specific XML name in any of the currently declared namespaces.

attribute::* or *@

Specifies attributes of the context node.

attribute-name

Identifies an attribute in an XML document. *attribute-name* is an XML QName that can have one of the following forms:

nsprefix:NCName

nsprefix explicitly specifies a namespace prefix that must be declared.

NCName

An unqualified XML name that uses the default namespace.

text()

Matches any text node.

fn:upper-case()

Specifies an element node or an attribute node that identifies the key value for the index for each node that is specified by the context step (the part of *pattern-expression* that is specified prior to *fn:upper-case*).

The context step of *fn:upper-case()* must specify an element node or an attribute node. The argument of *fn:upper-case()* must be a self step. The key values of an XML value index must be specified as the SQL data type VARCHAR. The length of the VARCHAR value can be any value that is allowed in Db2.

fn:exists()

Specifies an element node that identifies the key value for the index for each node that is specified by the context step (the part of *pattern-expression* that is specified prior to *fn:exists*).

The context step of *fn:exists()* must specify an element node. The argument of *fn:exists()* must be either a single step of a child element node or an attribute node. The name test part can be a wildcard character for either the namespace prefix or NCName. The key values of an XML value index for an XPath expression that ends with *fn:exists()* must be specified as the SQL data type VARCHAR(1). The key value will be "T" or "F". "T" implies that *fn:exists()* evaluates to true and "F" implies that *fn:exists()* evaluates to false.

AS SQL data-type

Specifies that indexed values are stored as an instance of the specified SQL data type. Casting to the specified data type can result in a loss of precision of the values. For example, a loss of precision can occur when an XML integer value is cast to the SQL data type DECFLOAT. If the cast causes a loss of precision, the result will be rounded to the approximate value when it is stored in the index. The cast result cannot be outside of the range that is supported by the SQL data type. If the value cannot be cast to the specified data type, the document is still inserted into the table, but the index entry for that value is not created. No error or warning code is returned.

If the index is unique, the uniqueness is enforced on the value after it is cast to the specified type. Because rounding can occur during the cast to the SQL data type, if a value is cast to the same key value as a document that the table already contains, Db2 will return duplicate key errors at insert time, or fail to create the index.

VARCHAR (*integer*)

The length *integer* is a value in the range 1–1000 bytes. If VARCHAR is specified with a length, the specified length is treated as a constraint. If documents are inserted into a table (or exist in the table at create index time) that have nodes with values that are longer than the specified length, the insert or index creation will fail.

DECFLOAT

DECFLOAT can be specified to index numeric values. For the cast to succeed, the string must be a valid XML numeric type. Otherwise the value will be ignored and no insert to the index will occur. The result of the cast cannot be outside of the range that DECFLOAT can represent. Because the XML Schema data type for numeric values allows greater precision than the SQL data type, the result might be rounded to fit into the SQL data type. The DECFLOAT values that are stored in the index are the normalized numeric values.

DATE

The SQL DATE data type values will be normalized to UTC (Coordinated Universal Time) before being stored in the index. For invalid xs:date values, the value will be ignored without being inserted into the index. The XML schema data type for DATE allows for greater precision than the SQL data type. If an out-of-range value is encountered, an error is returned.

TIMESTAMP (12)

The SQL TIMESTAMP data type values will be normalized to UTC (Coordinated Universal Time) before being stored in the index. If the value that is specified in the document does not specify the time zone, Db2 will use the implicit time zone to normalize the value to UTC. For invalid xs:dateTime values, the value will be ignored without being inserted into the index. The XML schema data type for timestamps allows for greater precision than the SQL data type. If an out-of-range value is encountered, an error is returned. Only a precision of 12 fractional digits is allowed for an SQL TIMESTAMP index key.

INCLUDE (*column-name*)

Specifies additional columns to append to the set of index key columns of a unique index. Any column that is specified using INCLUDE *column-name* is not used to enforce uniqueness. The included columns might improve performance for some queries using index only access.

The UNIQUE clause must be specified when INCLUDE is specified. Columns that are specified in the INCLUDE clause count towards the limits for the number of columns and the limits on the sum of the length attributes of the columns that are specified in the index. The total number of columns for the index cannot exceed 64.

column-name must be distinct from the columns that are used to enforce uniqueness and from other columns specified in the INCLUDE clause. *column-name* must be unqualified, must identify a column of the specified table, and must not be one of the existing columns of the index. *column-name* must not identify a LOB or DECFLOAT column (or a distinct type that is based on one of those types).

The INCLUDE clause cannot be specified for the following types of indexes:

- A non-unique index
- A partitioning index when index-controlled partitioning is used
- An auxiliary index
- An XML index
- An extended index
- An expression-based index

Columns in the INCLUDE list that are defined as character or graphic string data types must be defined with the same encoding scheme as other key columns with character or graphic string data types.

CLUSTER or NOT CLUSTER

Specifies whether the index is the clustering index for the table. This clause must not be specified for an index on an auxiliary table, or on a table that is defined to use hash organization.

CLUSTER

The index is to be used as the clustering index of the table. CLUSTER cannot be specified if XMLPATTERN or *key-expression* is specified.

NOT CLUSTER

The index is not to be used as the clustering index of the table.

PARTITIONED

Specifies that the index is data partitioned (that is, partitioned according to the partitioning scheme of the underlying data). A partitioned index can be created only on a partitioned table space, not on a partition-by-growth table space. PARTITIONED cannot be specified if XMLPATTERN is specified. The types of partitioned indexes are partitioning and secondary.

An index is considered a partitioning index if the specified index key columns match or comprise a superset of the columns specified in the partitioning key, are in the same order, and have the same ascending or descending attributes.

If PARTITION BY was not specified when the table was created, the CREATE INDEX statement must have the ENDING AT clause specified to define a partitioning index and use index-controlled partitioning. This index is created as a partitioned index even if the PARTITIONED keyword is not specified. When a partitioning index is created, if both the PARTITIONED and ENDING AT keywords are omitted, the index will be non-partitioned. If PARTITIONED is specified, the USING specification with PRIQTY and SECQTY specifications are optional. If these space parameters are not specified, default values are used.

A secondary index is any index defined on a partitioned table space that does not meet the definition of the partitioning index. For partitioned secondary indexes (data-partitioned secondary indexes), the ENDING AT clause is not allowed because the partitioning scheme of the index is predetermined by that of the underlying data. UNIQUE and UNIQUE WHERE NOT NULL are allowed only if the columns in the index are a superset of the partitioning columns. All of the index columns must be specified in a *table-name(column-name)* clause, and not in an INCLUDE clause. If a partitioned secondary index is created on a table that uses index-controlled partitioning, the table is converted to use table-controlled partitioning.

Index-controlled partitioning cannot be used if the PREVENT_NEW_IXCTRL_PART subsystem parameter is set to YES.

For more information, see [PREVENT_NEW_IXCTRL_PART](#) in macro DSN6SPRM (Db2 Installation and Migration).

NOT PADDED or PADDED

Specifies how varying-length string columns are to be stored in the index. If the index contains no varying-length columns, this option is ignored, and a warning message is returned. Indexes that do not have varying-length string columns are always created as physically padded indexes.

NOT PADDED

Specifies that varying-length string columns are not to be padded to their maximum length in the index. The length information for a varying-length column is stored with the key.

NOT PADDED is ignored and has no effect if the index is being created on an auxiliary table. Indexes on auxiliary tables are always padded.

PADDED

Specifies that varying-length string columns within the index are always padded with the default pad character to their maximum length. PADDED cannot be specified if XMLPATTERN is specified. PADDED cannot be specified for indexes that are defined on VARBINARY columns.

When the index contains at least one varying-length column, the default for the option depends on the value of field PAD INDEXES BY DEFAULT on installation panel DSNTIPE:

- When the value of this field is NO, new indexes are not padded unless PADDED is specified.
- When the value of this field is YES, new indexes are padded unless NOT PADDED is specified.

USING (for non-partitioned indexes)

For non-partitioned indexes, the USING clause indicates whether the data sets for the index are to be managed by the user or managed by Db2. If Db2 definition is specified, the clause also gives space allocation parameters (PRIQTY and SECQTY) and an erase rule (ERASE).

If you omit USING, the data sets Db2 manages on volumes listed in the default storage group of the database that is associated with the table. The default storage group for the database must exist. With no USING clause, PRIQTY, SECQTY, and ERASE assume their default values.

VCAT *catalog-name*

Specifies that the first data set for the index is managed by the user, and that following data sets, if needed, are also managed by the user.

The data sets are VSAM linear data sets cataloged in the integrated catalog facility catalog that *catalog-name* identifies. For more information about *catalog-name* values, see [“Naming conventions in SQL”](#) on page 79.

More than one Db2 subsystem can share the integrated catalog facility catalogs with the current server. To avoid the chance of those subsystems attempting to assign the same name to different data sets, specify a *catalog-name* value that is not used by the other Db2 subsystems.

Do not specify VCAT in any of the following circumstances:

- For an index on a declared temporary table.
- If the table space is partition-by-growth, and the table space is not part of the Db2 catalog.

STOGROUP *stogroup-name*

Specifies that Db2 will define and manage the data sets for the index. Each data set will be defined on a volume listed in the identified storage group. The values specified (or the defaults) for PRIQTY and SECQTY determine the primary and secondary allocations for the data set. If $PRIQTY+118 \times SECQTY$ is 2 gigabytes or greater, more than one data set could eventually be used, but only the first is defined during execution of this statement.

To use USING STOGROUP, the privilege set must include one of the following, except when creating an index on a declare global temporary table if *stogroup-name* matches the default storage group of the work file database:

- SYSADM authority
- SYSCTRL authority
- The USE privilege for that storage group

Moreover, *stogroup-name* must identify a storage group that exists at the current server and includes in its description at least one volume serial number. The description can indicate that the choice of volumes will be left to Storage Management Subsystem (SMS). Each volume specified in the storage group must be accessible to z/OS for dynamic allocation of the data set, and all these volumes must be of the same device type.

The integrated catalog facility catalog used for the storage group must **not** contain an entry for the first data set of the index. If the catalog is password protected, the description of the storage group must include a valid password.

The storage group supplies the data set name. The first level qualifier is also the name of, or an alias for, the integrated catalog facility catalog on which the data set is to be cataloged. The naming convention for the data set is the same as if the data set is managed by the user.

PRIQTY *integer*

Specifies the minimum primary space allocation for a Db2-managed data set. *integer* must be a positive integer, or -1. When you specify PRIQTY with a positive integer value, the primary space allocation is at least *n* kilobytes, where *n* is:

12

If *integer* is greater than 0 and less than 12.

integer

If *integer* is in the range 12–4194304.

2097152

If both of the following conditions are true:

- *integer* is greater than 2097152.
- The index is a non-partitioned index on a table space that is not defined with the LARGE or DSSIZE attribute.

4194304

If *integer* is greater than 4194304.

If you do not specify PRIQTY, or you specify a PRIQTY value of -1, Db2 uses a default value for the primary space allocation. For information on how Db2 determines the default value, see [Rules for primary and secondary space allocation](#).

If you specify PRIQTY, and do not specify a value of -1, Db2 specifies the primary space allocation to access method services using the smallest multiple of 4KB not less than *n*. The allocated space can be greater than the amount of space requested by Db2. For example, it could be the smallest number of tracks that will accommodate the space requested. To more closely estimate the actual amount of storage, see [DEFINE CLUSTER command \(DFSMS Access Method Services for Catalogs\)](#).

When determining a suitable value for PRIQTY, be aware that two of the pages of the primary space could be used by Db2 for purposes other than storing index entries.

SECQTY integer

Specifies the minimum secondary space allocation for a Db2-managed data set. *integer* must be a positive integer, 0, or -1. If you do not specify SECQTY, or specify a SECQTY value of -1, Db2 uses a formula to determine a value. For information on the actual value that is used for secondary space allocation, whether you specify a value or not, see [Rules for primary and secondary space allocation](#).

If you specify SECQTY, and do not specify a value of -1, Db2 specifies the secondary space allocation to access method services using the smallest multiple of 4KB not less than *integer*. The allocated space can be greater than the amount of space requested by Db2. For example, it could be the smallest number of tracks that will accommodate the space requested. To more closely estimate the actual amount of storage, see [DEFINE CLUSTER command \(DFSMS Access Method Services for Catalogs\)](#).

ERASE

Indicates whether the Db2-managed data sets are to be erased when they are deleted during the execution of a utility or an SQL statement that drops the index.

NO

Does not erase the data sets. Operations involving data set deletion will perform better than ERASE YES. However, the data is still accessible, though not through Db2. This is the default.

YES

Erases the data sets. As a security measure, Db2 overwrites all data in the data sets with zeros before they are deleted.

USING (partitioned indexes)

If the index is partitioned, there is a PARTITION clause for each partition. Within a PARTITION clause, a USING clause is optional. If a USING clause is present, it applies to that partition in the same way that a USING clause for a secondary index applies to the entire index.

When a USING specification is absent from a PARTITION clause, the USING clause parameters for the partition depend on whether a USING clause is specified before the PARTITION clauses.

- If the USING clause is specified, it applies to every PARTITION clause that does not include a USING clause.

- If the USING clause is not specified, the following defaults apply to the partition:
 - Data sets are managed by Db2.
 - The default storage group for the database is used. If the USING clause for the index space is omitted, the default storage group for database must exist.
 - Default values of -1 are used for both PRIQTY and SECQTY.
 - A value of NO is used for ERASE.

VCAT *catalog-name*

Specifies a user-managed data set with a name that starts with the specified catalog name. The identified integrated catalog facility catalog must already contain an entry for the *n*th data set of the index, where *n* is the partition number.

The data sets are VSAM linear data sets cataloged in the integrated catalog facility catalog that *catalog-name* identifies. For more information about *catalog-name* values, see [“Naming conventions in SQL”](#) on page 79.

More than one Db2 subsystem can share the integrated catalog facility catalogs with the current server. To avoid the chance of those subsystems attempting to assign the same name to different data sets, specify a *catalog-name* value that is not used by the other Db2 subsystems.

Db2 assumes one and only one data set for each partition.

STOGROUP *stogroup-name*

If USING STOGROUP is used, explicitly or by default, for a partition *n*, Db2 defines the data set for the partition during the execution of the CREATE INDEX statement, using space from the named storage group. The privilege set must include SYSADM authority, SYSCTRL authority, or the USE privilege for that storage group. The integrated catalog facility catalog used for the storage group must NOT contain an entry for the *n*th data set of the index.

stogroup-name must identify a storage group that exists at the current server and the privilege set must include one of the following privileges or authorities, except when creating an index on a declare global temporary table if *stogroup-name* matches the default storage group of the work file database:

- SYSADM authority
- SYSCTRL authority
- USE privilege for the storage group

If you omit PRIQTY, SECQTY, or ERASE from a USING STOGROUP clause for some partition, their values are given by the next USING STOGROUP clause that governs that partition: either a USING clause that is not in any PARTITION clause, or a default USING clause. Db2 assumes one and only one data set for each partition.

FREEPAGE *integer*

Specifies how often to leave a page of free space when index entries are created as the result of executing a Db2 utility or when creating an index for a table with existing rows. One free page is left for every *integer* pages. The value of *integer* can range 0–255. The default is 0, leaving no free pages.

Do not specify FREEPAGE for an index on a declared temporary table.

PCTFREE *integer*

Determines the percentage of free space to leave in each nonleaf page and leaf page when entries are added to the index or index partition as the result of executing a Db2 utility or when creating an index for a table with existing rows. The first entry in a page is loaded without restriction. When additional entries are placed in a nonleaf or leaf page, the percentage of free space is at least as great as *integer*.

The value of *integer* can range from 0 to 99, however, if a value greater than 10 is specified, only 10 percent of free space will be left in nonleaf pages. The default is 10.

Do not specify PCTFREE for an index on a declared temporary table.

If the index is partitioned , the values of FREEPAGE and PCTFREE for a particular partition are given by the first of these choices that applies:

- The values of FREEPAGE and PCTFREE given in the PARTITION clause for that partition. Do not use more than one *free-specification* in any PARTITION clause.
- The values given in a *free-specification* that is not in any PARTITION clause.
- The default values FREEPAGE 0 and PCTFREE 10.

GBPCACHE

In a data sharing environment, specifies what index pages are written to the group buffer pool. In a non-data-sharing environment, the option is ignored unless the index is on a declared temporary table. Do not specify GBPCACHE for an index on a declared temporary table in either environment (data sharing or non-data-sharing).

CHANGED

Specifies that updated pages are written to the group buffer pool, when there is inter-Db2 R/W interest on the index or partition. When there is no inter-Db2 R/W interest, the group buffer pool is not used. Inter-Db2 R/W interest exists when more than one member in the data sharing group has the index or partition open, and at least one member has it open for update. GBPCACHE CHANGED is the default.

If the index is in a group buffer pool that is defined as GBPCACHE(NO), CHANGED is ignored and no pages are written to the group buffer pool.

ALL

Indicates that pages are written to the group buffer pool as they are read in from DASD.

Exception: In the case of a single updating Db2 subsystem when no other Db2 subsystems have any interest in the page set, no pages are written to the group buffer pool.

If the index is in a group buffer pool that is defined as GBPCACHE(NO), ALL is ignored and no pages are written to the group buffer pool.

NONE

Indicates that no pages are written to the group buffer pool. Db2 uses the group buffer pool only for cross-invalidation.

If the index is partitioned, the value of GBPCACHE for a particular partition is given by the first of these choices that applies:

1. The value of GBPCACHE given in the PARTITION clause for that partition. Do not use more than one *gbpcache-specification* in any PARTITION clause.
2. The value given in a *gbpcache-specification* that is not in any PARTITION clause.
3. GBPCACHE CHANGED is the default value.

DEFINE

Specifies when the underlying data sets for the index are physically created. The SPACE column in catalog table SYSINDEXPART is used to record the status of the data sets (undefined or allocated). If the DEFINE keyword is not specified, the define attribute is inherited from the current state of the base table space.

YES

The data sets are created when the index is created (the CREATE INDEX statement is executed).

NO

The data sets are not created until data is inserted into the index.

DEFINE NO is applicable only for Db2-managed data sets (USING STOGROUP is specified). Use DEFINE NO especially when performance of the CREATE INDEX statement is important or DASD resource is constrained.

Do not use DEFINE NO on an index if you use a program outside of Db2 to propagate data into a table on which that index is defined. If you use DEFINE NO on an index of a table and data is then propagated into the table from a program that is outside of Db2, the index space data sets are

allocated, but the Db2 catalog will not reflect this fact. As a result, Db2 treats the data sets for the index space as if they have not yet been allocated. The resulting inconsistency causes Db2 to deny application programs access to the data until the inconsistency is resolved.

DEFINE NO is ignored for user-managed data sets (USING VCAT is specified). DEFINE NO is also ignored if the index is being created on a table that is not empty.

Do not specify DEFINE NO if the index is created on a base table that is involved in a clone relationship.

Do not specify DEFINE NO for an index on a declared temporary table.

COMPRESS NO or COMPRESS YES

Specifies whether compression for index data will be used. If the index is partitioned, the clause will apply to all partitions.

COMPRESS NO

Specifies that no index compression will be used.

COMPRESS NO is the default.

COMPRESS YES

Specifies that index compression will be used. The buffer pool that is used to create the index must be 8K, 16K, or 32K in size. The physical page size on disk will be 4K. The index compression will take place immediately.

Index compression is recommended for applications that do sequential insert operations with few or no delete operations. Random inserts and deletes can adversely effect compression. Index compress is also recommended for applications where the indexes are created primarily for scan operations.

INCLUDE NULL KEYS or EXCLUDE NULL KEYS

Specifies whether an index entry will be created when every key column contains the NULL value.

INCLUDE NULL KEYS

Specifies that an index entry will be created when every key column contains the NULL value.

INCLUDE NULL KEYS is the default.

EXCLUDE NULL KEYS

Specifies that no index entry will be created when every key column contains the NULL value. If any key column is not null the index entry will be created.

EXCLUDE NULL KEYS must not be specified with the following:

- UNIQUE
- BUSINESS_TIME WITHOUT OVERLAPS
- *XML-index-specification*
- *key-expression*
- INCLUDE (*column-name*)

EXCLUDE NULL KEYS must also not be specified if any of the columns that are identified by *column-name* are defined as NOT NULL, or if the index is defined as a partitioning index for use with index-controlled partitioning.

PARTITION BY RANGE

Specifies the partitioning index for the table, which determines the partitioning scheme for the data in the table.

PARTITION BY RANGE should only be specified if the table space is partitioned and the partitioning schema has not already been established.

PARTITION BY RANGE must not be specified if the index is an extended index, is defined with the BUSINESS_TIME WITHOUT OVERLAPS, or if the table is in a universal table space (ranged-partitioned or partition-by-growth table space).

partition-element

Specifies the range for each partition.

PARTITION *integer*

A PARTITION clause specifies the highest value of the index key in one partition of a partitioning index. In this context, highest means highest in the sorting sequences of the index columns. In a column defined as *ascending* (ASC), highest and lowest have their usual meanings. In a column defined as *descending* (DESC), the lowest actual value is highest in the sorting sequence.

If you use CLUSTER, and the table is contained in a partitioned table space, you must use exactly one PARTITION clause for each partition (defined with NUMPARTS on CREATE TABLESPACE). If there are *p* partitions, the value of *integer* must range from 1 through *p*.

The length of the highest value of a partition (also called the limit key) is the same as the length of the partitioning index.

ENDING AT(*constant*, MAXVALUE, or MINVALUE...)

Specifies that this is the partitioning index and indicates how the data will be partitioned. The table space is marked complete after this partitioning index is created. You must use at least one value (*constant*, MAXVALUE, or MINVALUE) after ENDING AT in each PARTITION clause. You can use as many as there are columns in the key. The concatenation of all the values is the highest value of the key in the corresponding partition of the index unless the VALUES statement was already specified when the table or previous index was created.

constant

Specifies a constant value with a data type that must conform to the rules for assigning that value to the column. If a string constant is longer or shorter than required by the length attribute of its column, the constant is either truncated or padded on the right to the required length. If the column is ascending, the padding character is X'FF'. If the column is descending, the padding character is X'00'. The precision and scale of a decimal constant must not be greater than the precision and scale of its corresponding column. A hexadecimal string constant (GX) cannot be specified.

MAXVALUE

Specifies a value greater than the maximum value for the limit key of a partition boundary (that is, all X'FF' regardless of whether the column is ascending or descending). If all of the columns in the partitioning key are ascending, a constant or the MINVALUE clause cannot be specified following MAXVALUE. After MAXVALUE is specified, all subsequent columns must be MAXVALUE.

MINVALUE

Specifies a value that is smaller than the minimum value for the limit key of a partition boundary (that is, all X'00' regardless of whether the column is ascending or descending). If all of the columns in the partitioning key are descending, a constant or the MAXVALUE clause cannot be specified following MAXVALUE. After MINVALUE is specified, all subsequent columns must be MINVALUE.

The key values are subject to the following rules:

- The first value corresponds to the first column of the key, the second value to the second column, and so on. Using fewer values than there are columns in the key has the same effect as using the highest or lowest values for the omitted columns, depending on whether they are ascending or descending.
- If a key includes a ROWID column or a column with a distinct type that is based on a ROWID data type, 17 bytes of the constant that is specified for the corresponding ROWID column are considered.
- The highest value of the key in any partition must be lower than the highest value of the key in the next partition.
- If the concatenation of all the values exceeds 255 bytes, only the first 255 bytes are considered.

- The highest value of the key in the last partition depends on how the table space is defined. For table spaces that are created without the LARGE or DSSIZE options, the values that you specify after VALUES are not enforced. The highest value of the key that can be placed in the table is the highest possible value of the key.

For large partitioned table space, the values you specify are enforced. The value specified for the last partition is the highest value of the key that can be placed in the table. Any key values greater than the value that is specified for the last partition are out of range.

ENDING AT can be specified only if the ENDING AT clause was not specified on a previous CREATE or ALTER TABLE statement for the underlying table.

INCLUSIVE

Specifies that the specified range values are included in the data partition.

BUFFERPOOL *bpname*

Identifies the buffer pool that is to be used for the index. The privilege set must include SYSADM or SYSCTRL authority or the USE privilege for the buffer pool, except when creating an index on a declared global temporary table and *bpname* matches the default index buffer pool of the work file database.

The *bpname* must identify an activated 4KB, 8KB, 16KB, or 32KB buffer pool.

A buffer pool with a smaller size should be chosen for indexes with random insert patterns. A buffer pool with a larger size should be chosen for indexes with sequential insert patterns.

For more details about *bpname*, see [“Naming conventions in SQL” on page 79](#). For a description of active and inactive buffer pools, see [Controlling Db2 databases and buffer pools \(Db2 Administration Guide\)](#).

CLOSE

Specifies whether or not the data set is eligible to be closed when the index is not being used and the limit on the number of open data sets is reached.

YES

Eligible for closing. This is the default unless the index is on a declared temporary table.

NO

Not eligible for closing.

If the limit on the number of open data sets is reached and there are no page sets that specify CLOSE YES to close, page sets that specify CLOSE NO will be closed.

For an index on a declared temporary table, Db2 uses CLOSE NO regardless of the value specified.

DEFER

Indicates whether the index is built during the execution of the CREATE INDEX statement. Regardless of the option specified, the description of the index and its index space is added to the catalog. If the table is determined to be empty and DEFER YES is specified, the index is neither built nor placed in a rebuild-pending status. For more information about using DEFER, see [Index names and guidelines \(Db2 Administration Guide\)](#). Do not specify DEFER for an index on a declared temporary table or an auxiliary table.

NO

The index is built. This is the default.

YES

The index is not built. If the table is populated, the index is placed in a rebuild-pending status and a warning message is issued; the index must be rebuilt by the REBUILD INDEX utility.

DSSIZE *integer G*

Specifies the maximum size for each partition of a partitioned index. Any integer 1–1024 can be specified (for example, 1 G or 1024 G). This keyword is not valid on nonpartitioned secondary indexes. You can only specify DSSIZE on CREATE INDEX if the index is on a table space with relative page numbers.

To specify a value greater than 4G, the data sets for the table space must be associated with a DFSMS data class that has been specified with extended format and extended addressability.

If the index is a partitioned index using relative page numbering, the value of DSSIZE for a particular partition is given by the first of these choices that applies:

- The value of DSSIZE given in the PARTITION clause for that partition.
- The value given by a DSSIZE keyword that is not in any PARTITION clause.
- The default value is inherited from the base table space.

integer can be separated from G by 0 or more spaces.

PIECESIZE *integer*

Specifies the maximum addressability of each data set for a non-partitioned index. The subsequent keyword K, M, or G, indicates the units of the value that is specified in *integer*.

K

Indicates that the *integer* value is to be multiplied by 1024 to specify the maximum data set size in bytes. *integer* must be a power of two in the range 1–268435456.

M

Indicates that the *integer* value is to be multiplied by 1048576 to specify the maximum data set size in bytes. *integer* must be a power of two in the range 1–262144.

G

Indicates that the *integer* value is to be multiplied by 1073741824 to specify the maximum data set size in bytes. *integer* must be a power of two in the range 1–256.

integer can be separated from K, M, or G by 0 or more spaces. *integer*

The following table shows the valid values for the data set size, which depend on the size of the table space.

Table 196. Valid values of PIECESIZE clause

K units	M units	G units	Size attribute of table space
256K			
512 K			
1024 K	1 M		
2048 K	2 M		
4096 K	4 M		
8192 K	8 M		
16384 K	16 M		
32768 K	32 M		
65536 K	64 M		
131072 K	128 M		
262144 K	256 M		
524288 K	512 M		
1048576 K	1024 M	1 G	
2097152 K	2048 M	2 G	
4194304 K	4096 M	4 G	LARGE, DSSIZE 4 G (or greater)
8388608 K	8192 M	8 G	DSSIZE 8 G (or greater)
16777216 K	16384 M	16 G	DSSIZE 16 G (or greater)
33554432 K	32768 M	32 G	DSSIZE 32 G (or greater)

Table 196. Valid values of PIECESIZE clause (continued)

K units	M units	G units	Size attribute of table space
67108864 K	65536 M	64 G	DSSIZE 64 G (or greater)
134217728 K	131072 M	128 G	DSSIZE 128 G (or greater)
268435456 K	262144 M	256 G	DSSIZE 256 G

PIECESIZE has no effect on primary and secondary space allocation as it is only a specification of the maximum amount of data that a data set can hold and not the actual allocation of storage.

If you change the PIECESIZE value with the ALTER INDEX statement, the index is put into REBUILD-pending status.

See the following for additional information:

- [Number of pieces and maximum piece size for non-partitioned indexes and data-partitioned secondary indexes](#)
- [Choosing a value for PIECESIZE](#)

COPY

Indicates whether the COPY utility is allowed for the index. Do not specify COPY for an index on a declared temporary table.

NO

Does not allow full image or concurrent copies or the use of the RECOVER utility on the index. NO is the default.

YES

Allows full image or concurrent copies and the use of the RECOVER utility on the index.

Notes for CREATE INDEX

Owner privileges:

The owner of the table has all table privileges (see [“GRANT statement \(table or view privileges\)” on page 1988](#)) with the ability to grant these privileges to others. For more information about ownership of the object, see [“Authorization, privileges, permissions, masks, and object ownership” on page 90](#).

Effects of the DEFER clause:

If DEFER NO is implicitly or explicitly specified, the CREATE INDEX statement cannot be executed while a Db2 utility has control of the table space that contains the identified table.

If the identified table already contains data and if the index build is not deferred, CREATE INDEX creates the index entries for it. If the table does not yet contain data, CREATE INDEX creates a description of the index; the index entries are created when data is inserted into the table.

Errors evaluating the expressions for an index:

Errors that occur during the evaluation of an expression for an index are returned when the expression is evaluated. This can occur on an SQL data change statement, SELECT from an SQL data change statement, or the REBUILD INDEX utility. For example, the evaluation of the expression $10 / column_1$ returns an error if the value in *column_1* is 0. The error is returned during CREATE INDEX processing if the table is not empty and contains a row with a value of zero in *column_1*, otherwise the error is returned during the processing of the insert or update operation when a row with a value of zero in *column_1* is inserted or updated.

Result length of expressions that return a string type:

If the result data type of *key-expression* is a string type and the result length cannot be calculated at bind time, the length is set to the maximum allowable length of that data type or the largest length that Db2 can estimate. In this case, the CREATE INDEX statement can fail because the total key length might exceed the limit of an index key.

For example, the result length of the expression `REPEAT('A', CEIL(1.1))` is VARCHAR(32767) and the result length of the expression `SUBSTR(DESCRIPTION, 1, INTEGER(1.2))` is the length of

the DESCRIPTION column. Therefore, a CREATE INDEX statement that uses any of these expressions as a *key-expression* might not be created because the total key length might exceed the limit of an index key.

Use of ASC or DESC on key columns:

There are no restrictions on the use of ASC or DESC for the columns of a parent key or foreign key. An index on a foreign key does not have to have the same ascending and descending attributes as the index of the corresponding parent key.

EBCDIC, ASCII, and UNICODE encoding schemes for an index:

In general, an index has the same encoding scheme as its associated table. However, if an index on an EBCDIC table consists of only Unicode columns, the encoding scheme of the index is Unicode.

Maximum partition size of a partitioned index

The size of a partitioned index depends on whether the corresponding partitioned table space is created with or without the LARGE or DSSIZE keywords, and on the number of partitions.

The following table provides information about partitioned indexes on table spaces that are created without the LARGE or DSSIZE keywords and with 64 or fewer partitions.

Table 197. Maximum number of pieces and the default size of a partitioned index on a partitioned table space that is created without the LARGE or DSSIZE clauses and with a NUMPARTS value of less than or equal to 64

Definition of partitioned table space (non-large)	Maximum number of pieces for a partitioned index	Default size of a partitioned index, per data set
NUMPARTS <= 16	16	4G
NUMPARTS >= 17 but NUMPARTS <= 32	32	2G
NUMPARTS >= 33	64	1G

The following table shows information about partitioned indexes on table spaces that are created with the LARGE or DSSIZE keywords and with more than 64 partitions.

Table 198. Maximum number of pieces and the default partitioned index size for a partitioned table space that is created with the LARGE or DSSIZE clauses or with a NUMPARTS value of greater than 64

Definition of partitioned table space (large)	Maximum number of pieces for a partitioned index	Default index piece size for a partitioned index
One or more of the following conditions are true: <ul style="list-style-type: none"> • LARGE clause - specified • NUMPARTS greater than 64 but less than 256 	Maximum number of partitions in the partitioned table space	4G
One or more of the following conditions are true: <ul style="list-style-type: none"> • DSSIZE clause - specified • NUMPARTS greater than or equal to 256 	Maximum number of partitions in the partitioned table space	$\text{MIN}(\text{table space DSSIZE}, 2^{32} / (\text{Maximum number of partitions in the table space}) * \text{index page size})$

To calculate the maximum data set size for a partitioned index, you need to first calculate the maximum number of partitions in the table space by using the following formula:

$$\text{MIN}(4096, 2^{32} / (\text{table space DSSIZE} / \text{table space page size}))$$

After you calculate the maximum number of partitions in the table space, you can calculate the maximum data set size for a partitioned index with the following formula, using the number of partitions that you calculated above:

$$\text{MIN}(\text{table space DSSIZE}, 2^{32}/(\text{Maximum number of partitions in the table space}) * \text{index page size})$$

For an index that is defined with COMPRESS YES, *index page size* is always 4096 (4KB).

For example, suppose that a table space and an index on that table space have the following characteristics:

- DSSIZE: 64 GB
- Page size: 32 KB
- Index page size: 4 KB
- Maximum number of partitions: 2048

Given those characteristics, you can begin by calculating the maximum number of partitions in the table space:

$$\text{MIN}(4096, 2^{32}/(64\text{GB} / 32\text{KB})) = \mathbf{2048}$$

You can then use the value of 2048 to calculate the maximum data set size for the partitioned index:

$$\begin{aligned} &\text{MIN}(64 \text{ GB}, 2^{32}/\mathbf{2048} * 4\text{KB}) \\ &= \text{MIN}(64\text{GB}, 8\text{GB}) \\ &= 8\text{GB} \end{aligned}$$

Number of pieces and maximum piece size for non-partitioned indexes

The largest amount of data that an index can hold is the maximum number of pieces for the index times the maximum amount of data that a piece can hold.

For a non-partitioned index, the maximum amount of data that an index can hold is defined by using the PIECESIZE parameter.

The default piece size for an index is as follows:

- 2 GB (PIECESIZE 2 G) for indexes of table spaces created without the LARGE or DSSIZE option
- 4 GB (PIECESIZE 4 G) for indexes of table spaces created with the LARGE or DSSIZE option
- 4 GB (PIECESIZE 4 G) for auxiliary indexes

The following tables list the maximum number of pieces and the default index piece size for various table spaces.

Table 199. Maximum number of pieces and the default index piece size for a partitioned table space that is created without the LARGE or DSSIZE clauses and has a Numpart value of less than or equal to 64

Definition of partitioned table space (non-large), Numpart value	Maximum number of pieces in a non-partitioned index	Default index piece size for a non-partitioned index
NUMPARTS <= 16	32	2G
NUMPARTS >= 17 but NUMPARTS <= 32	32	2G
NUMPARTS >= 33	32	2G

Table 200. Maximum number of pieces and the default index piece size for a partitioned table space that is created with the LARGE or DSSIZE clauses or has a Numparts value of greater than or equal to 65

Definition of partitioned table space (large)	Maximum number of pieces for a non-partitioned index	Default index piece size for a non-partitioned index
<ul style="list-style-type: none"> • LARGE clause - specified • DSSIZE clause - not specified 	$\text{MIN}(4096, 2^{32}/(x/y))$ - see "1" on page 1549	4G
<ul style="list-style-type: none"> • LARGE clause - not specified • DSSIZE clause - not specified • NUMPARTS clause - greater than 64 but less than 256 	$\text{MIN}(4096, 2^{32}/(x/y))$ - see "1" on page 1549	4G
<ul style="list-style-type: none"> • LARGE clause - not specified • DSSIZE clause - specified or NUMPARTS clause - greater than or equal to 256 	$\text{MIN}(4096, 2^{32}/(x/y))$ - see "1" on page 1549	4G

Note:

1. For a non-partitioned index, the formula $\text{MIN}(4096, 2^{32} / (x / y))$, determines the maximum number of pieces for the non-partitioned index, where x and y have the following values:
 - x is the piece size of the index (stored in the PIECESIZE column of the SYSIBM.SYSINDEXES catalog table)
 - y is the page size of the index (stored in the PGSIZE column of the SYSIBM.SYSINDEXES catalog table)

Table 201. Maximum number of pieces and the default index piece size for a non-partitioned table space

Type of non-partitioned table space	Maximum number of pieces	Default index piece size
non-segmented table space	32	2G
segmented table space	32	2G
LOB, auxiliary, or XML table space	32	4G

Choosing a value for PIECESIZE:

To choose a value for PIECESIZE, divide the size of the non-partitioned index by the number of data sets that you want. For example, to ensure that you have five data sets for the non-partitioned index, and your index is 10MB (and not likely to grow much), specify PIECESIZE 2 M. If your non-partitioned index is likely to grow, choose a larger value.

Remember that 32 data sets is the limit if the underlying table space is not defined as LARGE or with a DSSIZE parameter and that the limit is 4096 for objects with greater than 254 parts. For a non-partitioned index on a table space that is defined as LARGE or with a DSSIZE parameter, the maximum is $\text{MIN}(4096, 2^{32} / (\text{index piece size}/\text{index page size}))$.

Keep the PIECESIZE value in mind when you are choosing values for primary and secondary quantities. Ideally, the value of your primary quantity plus the secondary quantities should be evenly divisible into PIECESIZE.

Dropping an index:

Partitioning indexes can be dropped. If the table space is using index-controlled partitioning, the table space is converted to table-controlled partitioning. Secondary indexes that are not indexes on auxiliary tables can be dropped simply by dropping the indexes. An empty index on an auxiliary table can be explicitly dropped; a populated index can be dropped only by dropping other objects. For details, see [Dropping an index on an auxiliary table and an auxiliary table](#) "Dropping an index on a base table and auxiliary table" in ["DROP statement"](#) on page 1886.

If the index is a unique index that enforces a primary key, unique key, or referential constraint, the constraint must be dropped before the index is dropped. See ["DROP statement"](#) on page 1886.

Unique indexes and enforcement of UNIQUE or PRIMARY KEY specifications for a table:

A table requires a unique index (that is not defined as UNIQUE WHERE NOT NULL) if you use the UNIQUE or PRIMARY KEY clause in the CREATE or ALTER TABLE statements, or if there is a ROWID column that is defined as GENERATED BY DEFAULT. Db2 implicitly creates those unique indexes if the table space is explicitly created and the CREATE or ALTER TABLE statement is processed by the schema processor or if the table space is implicitly created; otherwise, you must explicitly create them. If any of the unique indexes that must be explicitly defined do not exist, the definition of the table is incomplete, and the following rules apply:

- Let K denote a key for which a required unique index does not exist and let n denote the number of unique indexes that remain to be created before the definition of the table is complete. (For a new table that has no indexes, K is its primary key or any of the keys defined in the CREATE or ALTER TABLE statement as UNIQUE and n is the number of such keys. After the definition of a table is complete, an index cannot be dropped if it is enforcing a primary key or unique key.)
- The creation of the unique index reduces n by one if the index key is identical to K . The keys are identical only if they have the same columns in the same order.
- If n is now zero, the creation of the index completes the definition of the table.
- If K is a primary key, the description of the index indicates that it is a primary index. If K is not a primary key, the description of the index indicates that it enforces the uniqueness of a key defined as UNIQUE in the CREATE or ALTER TABLE statement.

A unique index cannot be created on a materialized query table.

Unique indexes and XML columns:

If the index is an XML index on a unique XML column, the uniqueness applies to values of the specified pattern across all documents of that column, and the uniqueness is enforced on the value after the value is cast to the specified SQL data type. Because the data type conversion might result in a loss of precision and normalization, multiple values that appear unique in the XML document might still result in duplicate errors. If the index is defined using an expression, the uniqueness is enforced against the values that are stored in the index, not against the original values of the columns. The WHERE NOT NULL specification is ignored with a warning if XMLPATTERN is also specified, and the index is treated as if UNIQUE had been specified.

Defining an XML index using an XPath pattern-expression that includes functions:

An XPath *pattern-expression* that includes functions (including fn:exists() or fn:upper-case()) will have two parts. The first part is referred to as the *context step* and specifies the XPath of the element node or attribute node for which an index entry will be created (the element or attributes NodeID will be included in the index). The context step follows the same syntax as the XPath *pattern-expression* for an XML index, except that for fn:exists() it has to specify an element node, and for fn:upper-case() it has to specify an element node or an attribute node.

The second part is referred to as the *function expression step* and specifies the fn:exists() or fn:upper-case() XPath function. The function expression step is the right-most part of an XPath *pattern-expression*. For each node specified by the context step, the function expression step specifies the key value for the index. For example, in the XPath *pattern-expression* /purchaseOrder/items/item/fn:exists(shipDate), the context step is /purchaseOrder/items/item, and the function expression step is fn:exists(shipDate).

Use of PARTITIONED keyword:

When a partitioned index is created and no additional keywords are specified, the index is non-partitioned. If the keyword PARTITIONED is specified, the index is partitioned. If PARTITION BY RANGE is specified, the index is both data-partitioned and key-partitioned because it is defined on the partitioning columns of the table. Any index on a partitioned table space that does not meet the definition of a partitioning index is a secondary index. When a secondary index is created and no additional keywords are specified, the secondary index is non-partitioned (NPSI). If the keyword PARTITIONED is specified, the index is a data-partitioned secondary index (DPSI).

Creating a partitioning index for a table created without partition boundaries:

When a table is created without specifying partition boundaries using the ENDING AT clause, the table is incomplete until a partitioning index is created. The first index that is created for a table must specify both the PARTITION and the ENDING AT clauses.

When the PARTITION clause is specified while creating an index, either the PARTITIONED clause, or the ENDING AT clause must also be specified.

Considerations for tables that are involved in a clone relationship:

If an index is created on a base table that is involved in a clone relationship, an index with the same name is also created on the clone table. The index on the clone table will be placed in rebuild-pending status unless the clone table is empty when the index is created.

Considerations for tables that contain a row change timestamp column:

To create an index that refers to a row change timestamp column in the table, values must already exist in the column for all rows. Values are stored in row change timestamp columns whenever a row is inserted or updated in the table. If the row change timestamp column is added to an existing table that contains rows, the values for the row change timestamp column is not materialized and stored at the time of the ALTER TABLE statement. Values are materialized for these rows when they are updated, or when a REORG or a LOAD REPLACE utility is run on the table or table space.

Restriction on table spaces when there are pending changes to the definition:

A CREATE INDEX statement is not allowed if there are pending changes to the definition of the table space or to any objects in the table space. In addition, an index that references an expression cannot be created on a table where the inline length of a LOB column has been changed and the table space has not been reorganized.

Effects of DEFINE NO and INCLUDE NULL KEYS or EXCLUDE NULL KEYS:

When INCLUDE NULL KEYS is specified (implicitly or explicitly) with DEFINE NO and the table that is being indexed is populated, a warning is returned, the index is created, and the data set is defined. When EXCLUDE NULL KEYS is specified, it is possible that the data set will not be defined if the all rows for the table that is being indexed contain the NULL value for all key columns. The index will be empty after the CREATE INDEX statement. However, if DEFINE NO is specified with EXCLUDE NULL KEYS a warning is returned.

Creating indexes on Db2 catalog tables:

For details on creating indexes on catalog tables, see [“SQL statements allowed on the catalog” on page 2739](#).

EA-enabled index data sets:

If an index is created for an EA-enabled table space, the data sets for the index must be set up to belong to a DFSMS data class that has the extended format and extended addressability attributes.

Alternative syntax and synonyms:

To provide compatibility with previous releases of Db2 or other products in the Db2 family, Db2 supports the following keywords when creating a partitioned index:

- PART *integer* VALUES as an alternative syntax for PARTITION *integer* ENDING. The PARTITION BY RANGE keyword that precedes the *partition-element* clause is optional.

Although these keywords are supported as alternatives, they are not the preferred syntax.

User-defined indexes on catalog tables:

If you issue CREATE INDEX for an index on a catalog table, and you specify the USING clause, Db2 ignores that clause. Instead, Db2 defines and manages the index data sets. The data sets are defined in the same SMS environment that is used for the catalog data sets with default space attributes.

Temporal referential constraints:

An index is required for the foreign key of a temporal referential constraint. The index must be defined in one of the following ways:

- Specify the BUSINESS_TIME WITH OVERLAPS clause after the columns and key expressions.
- Specify the end column of the BUSINESS_TIME period, followed by the begin column of the BUSINESS_TIME period as the last two keys of the index. ASC must be used for each of these columns.

When a temporal referential constraint is defined for a table, the first index that is created that meets the criteria for an index on the foreign key, is recorded as a dependency for the constraint. An index used for the foreign key of a temporal referential constraint cannot be dropped. A column cannot be added to an index used for a temporal referential constraint.

Examples for CREATE INDEX

Example 1

Create a unique index, named DSN8C10.XDEPT1, on table DSN8C10.DEPT. Index entries are to be in ascending order by the single column DEPTNO. Db2 is to define the data sets for the index, using storage group DSN8G120. Each data set should hold 1 megabyte of data at most. Use 512 kilobytes as the primary space allocation for each data set and 64 kilobytes as the secondary space allocation. These specifications enable each data set to be extended up to 8 times before a new data set is used— $512\text{KB} + (8 \times 64\text{KB}) = 1024\text{KB}$. Make the index padded.

The data sets can be closed when no one is using the index and do not need to be erased if the index is dropped.

```
CREATE UNIQUE INDEX DSN8C10.XDEPT1
ON DSN8C10.DEPT
  (DEPTNO ASC)
PADDED
USING STOGROUP DSN8G120
  PRIQTY 512
  SECQTY 64
  ERASE NO
BUFFERPOOL BP1
CLOSE YES
PIECESIZE 1 M;
```

For the above example, the underlying data sets for the index will be created immediately, which is the default (DEFINE YES). Assuming that table DSN8C10.DEPT is empty, if you wanted to defer the creation of the data sets until data is first inserted into the index, you would specify DEFINE NO instead of accepting the default behavior. Specifying PADDED ensures that the varying-length character string columns in the index are padded with blanks.

Example 2

Create a cluster index, named XEMP2, on table EMP in database DSN8C10. Put the entries in ascending order by column EMPNO. Let Db2 define the data sets for each partition using storage group DSN8G120. Make the primary space allocation be 36 kilobytes, and allow Db2 to use the default value for SECQTY, which for this example is 12 kilobytes (3 times 4KB). If the index is dropped, the data sets need not be erased.

There are to be 4 partitions, with index entries divided among them as follows:

- Partition 1: entries up to H99
- Partition 2: entries above H99 up to P99
- Partition 3: entries above P99 up to Z99

Partition 4: entries above Z99

Associate the index with buffer pool BP1 and allow the data sets to be closed when no one is using the index. Enable the use of the COPY utility for full image or concurrent copies and the RECOVER utility.

```
CREATE INDEX DSN8C10.XEMP2
ON DSN8C10.EMP
(EMPNO ASC)
USING STOGROUP DSN8G120
PRIQTY 36
ERASE NO
CLUSTER
PARTITION BY RANGE
(PARTITION 1 ENDING AT('H99'),
PARTITION 2 ENDING AT('P99'),
PARTITION 3 ENDING AT('Z99'),
PARTITION 4 ENDING AT('999'))
BUFFERPOOL BP1
CLOSE YES
COPY YES;
```

Example 3

Create a secondary index, named DSN8C10.XDEPT1, on table DSN8C10.DEPT. Put the entries in ascending order by column DEPTNO. Assume that the data sets are managed by the user with catalog name DSNCAT and each data set is to hold 1GB of data, at most, before the next data set is used.

```
CREATE UNIQUE INDEX DSN8C10.XDEPT1
ON DSN8C10.DEPT
(DEPTNO ASC)
USING VCAT DSNCAT
PIECESIZE 1048576 K;
```

Example 4

Assume that a column named EMP_PHOTO with a data type of BLOB(110K) was added to the sample employee table for each employee's photo and auxiliary table EMP_PHOTO_ATAB was created in LOB table space DSN8D12A.PHOTOLTS to store the BLOB data for the column. Create an index named XPHOTO on the auxiliary table. The data sets are to be user-managed with catalog name DSNCAT.

```
CREATE UNIQUE INDEX DSN8C10.XPHOTO
ON DSN8C10.EMP_PHOTO_ATAB
USING VCAT DSNCAT
COPY YES;
```

In this example, no columns are specified for the key because auxiliary indexes have implicitly generated keys.

Related concepts

[Implementing Db2 indexes \(Db2 Administration Guide\)](#)

[Naming conventions](#)

The rules for forming a name depend on the type of the object designated by the name.

CREATE LOB TABLESPACE

The CREATE LOB TABLESPACE statement defines a large object (LOB) table space at the current server. If your data for a table does not fit entirely within a data page, you can define one or more columns as LOB columns. Each LOB column must have an associated auxiliary table in a LOB table space. If the table space for the base table is partitioned, an associated auxiliary table in a LOB table space is required for each LOB column, for each partition of the table space for the base table.

Do not use this statement if Db2 implicitly creates the LOB table space. For more information, see [LOB table space implicit creation \(Db2 Administration Guide\)](#).

For information about explicitly creating an auxiliary table, which defines the relationship between the LOB column of the base table and a LOB table space, see [“CREATE AUXILIARY TABLE statement” on page 1418](#).

For information about creating table spaces other than LOB table spaces, see [“CREATE TABLESPACE statement” on page 1718](#).

Invocation for CREATE LOB TABLESPACE

This statement can be embedded in an application program or issued interactively. It is an executable statement that can be dynamically prepared only if DYNAMICRULES RUN behavior is in effect. For more information, see [“Authorization IDs and dynamic SQL” on page 94](#).

Authorization for CREATE LOB TABLESPACE

The privilege set that is defined below must include at least one of the following:

- The CREATETS privilege for the database
- DBADM, DBCTRL, or DBMAINT authority for the database
- SYSADM or SYSCTRL authority
- System DBADM
- Installation SYSOPR authority (when the current SQLID of the process is set to SYSINSTL)

If the database is implicitly created, the database privileges must be on the implicit database or on DSNDB04.

Additional privileges might be required, as explained in the description of the BUFFERPOOL and USING STOGROUP clauses.

Privilege set: If the statement is embedded in an application program, the privilege set is the privileges that are held by the owner of the plan or package. If the application is bound in a trusted context with the ROLE AS OBJECT OWNER clause specified, a role is the owner. Otherwise, an authorization ID is the owner.

If the statement is dynamically prepared, the privilege set is the privileges that are held by the SQL authorization ID of the process unless the process is within a trusted context and the ROLE AS OBJECT OWNER clause is specified. In that case, the privileges set is the privileges that are held by the role that is associated with the primary authorization ID of the process.

Syntax for CREATE LOB TABLESPACE

→ CREATE LOB TABLESPACE — *table-space-name* →

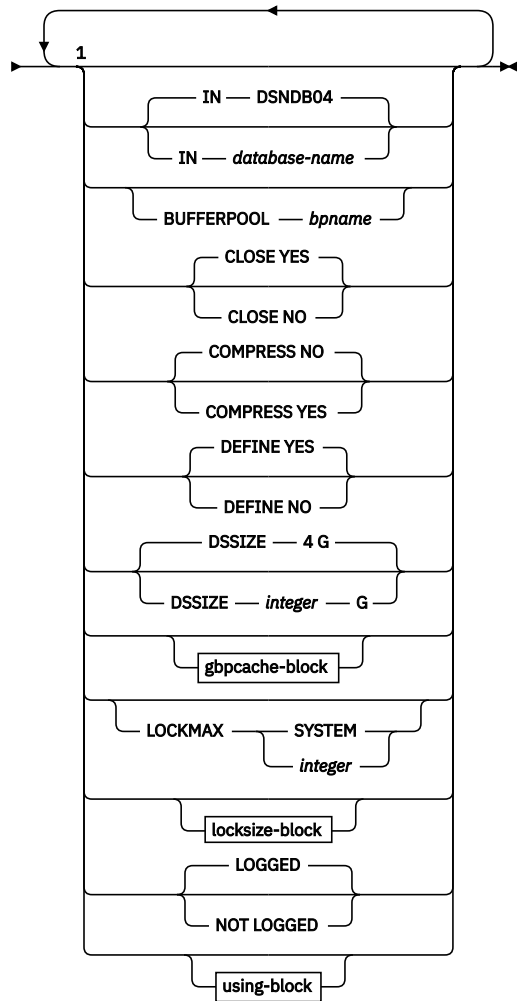

Notes:

¹ The same clause must not be specified more than one time.

gbpcache-block:

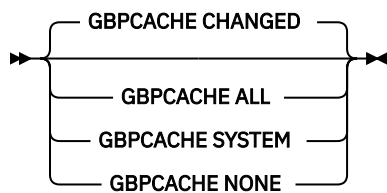

locksize-block:

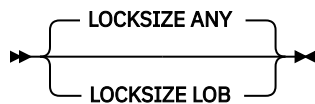

using-block:

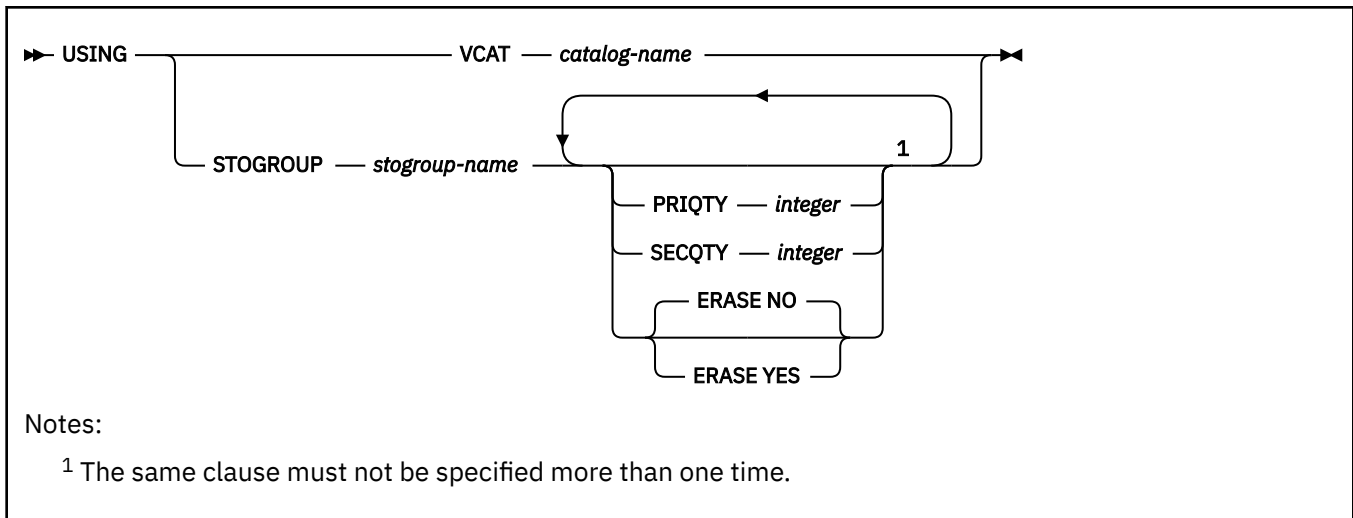

table-space-name

Names the table space. The name, qualified with the *database-name* implicitly or explicitly specified by the IN clause, must not identify a table space, index space, or LOB table space that exists at the current server, or that exists in the SYSPENDINGOBJECTS catalog table.

IN database-name

Specifies the database in which the table space is created. The LOB table space must be in the same database as its associated base table space. *database-name* must identify a database that exists at the current server and must not specify the following:

- DSNDB06
- A work file database
- A TEMP database
- An implicitly created database

DSNDB04 is the default.

BUFFERPOOL bpname

Identifies the buffer pool to be used for the table space and determines the page size of the table space. For 4KB, 8KB, 16KB and 32KB page buffer pools, the page sizes are 4 KB, 8 KB, 16 KB, and 32 KB, respectively. The *bpname* must identify an activated buffer pool, and the privilege set must include SYSADM or SYSCTRL authority, or the USE privilege on the buffer pool.

If you do not specify the BUFFERPOOL clause, the default buffer pool is the buffer pool that is specified in the DEFAULT BUFFER POOL FOR USER LOB DATA field on installation panel DSNTIP1.

See “Naming conventions in SQL” on page 79 for more details about *bpname*. See `-ALTER BUFFERPOOL` command (Db2) (Db2 Commands) for a description of active and inactive buffer pools.

CLOSE

When the limit on the number of open data sets is reached, specifies the priority in which data sets are closed.

YES

Eligible for closing before CLOSE NO data sets. CLOSE YES is the default value.

NO

Eligible for closing after all eligible CLOSE YES data sets are closed.

COMPRESS

Specifies whether data compression applies to the LOB data in the table space.

The following conditions are required for LOB compression in Db2 for z/OS:

- Db2 12 must be at function level 500 or higher.

- The zEDC hardware and software must be available and configured in the z/OS system. For more information, see [Requirements for zEnterprise Data Compression](#).

In data sharing, system performance can degrade dramatically if a member accesses compressed LOB data and the zEDC hardware and software are not configured in z/OS.

- The LOB table space must be associated with a base table that is in a universal table space.
- The total length of the entire LOB must be larger than the defined data page size, otherwise the LOB is not compressed.

For more information, see [Compressing LOB data \(Db2 Performance\)](#).

YES

Specifies data compression. The LOB data is not compressed until the LOAD or REORG utility is run on the table in the table space, or until an insert operation is performed through the insert operation.

NO

Specifies no data compression for the table space.

DEFINE

Specifies when the underlying data sets for the table space are physically created.

YES

The data sets are allocated when the table space is created (when the CREATE LOB TABLESPACE statement is executed). YES is the default.

NO

The data sets are not allocated until data is inserted into the table space. DEFINE NO is applicable only for Db2-managed data sets (USING STOGROUP is specified). DEFINE NO is ignored for user-managed data sets (USING VCAT is specified). Db2 uses the SPACE column in catalog table SYSTABLEPART to record the status of the data sets (undefined or allocated).

DEFINE NO is not recommended if you intend to use any tools outside of Db2 to manipulate data, such as to load data, because data sets might then exist when Db2 does not expect them to exist. When Db2 encounters this inconsistent state, applications will receive an error.

For table spaces that are created with DEFINE NO, point-in-time recover will not work before data sets exist and before a recovery copy exists.

DSSIZE *integer G*

Specifies the maximum size of each data set in *integer* gigabytes for each data set in the LOB table space.

If DSSIZE is not specified, the default value is 4 G. The maximum number of data sets is 254.

To specify a value greater than 4 G, the data sets for the table space must be associated with a DFSMS data class that has been specified with extended format and extended addressability.

For a description of the maximum size of a LOB table space (or the maximum size of LOB data for each column of a base table), see [LOB table spaces \(Db2 Administration Guide\)](#).

GBPCACHE

In a data sharing environment, specifies what pages of the table space are written to the group buffer pool. In a non-data-sharing environment, you can specify GBPCACHE, but it is ignored.

CHANGED

When there is inter-Db2 R/W interest on the table space, updated pages are written to the group buffer pool. When there is no inter-Db2 R/W interest, the group buffer pool is not used. Inter-Db2 R/W interest exists when more than one member in the data sharing group has the table space open, and at least one member has it open for update. GBPCACHE CHANGED is the default.

Recommendation: Use the GBPCACHE CHANGED option. Due to the usage patterns of LOBs, the use of GBPCACHE CHANGED can help avoid excessive and synchronous writes to disk and to the group buffer pool.

If the table space is in a group buffer pool that is defined to be used only for cross-invalidation (GBPCACHE NO), CHANGED is ignored and no pages are cached to the group buffer pool.

ALL

Indicates that pages are to be cached in the group buffer pool as they are read in from DASD.

Exception: In the case of a single updating Db2 member when no other Db2 member has any interest in the page set, no pages are cached in the group buffer pool.

If the table space is in a group buffer pool that is defined to be used only for cross-invalidation (GBPCACHE NO), ALL is ignored and no pages are cached to the group buffer pool.

SYSTEM

Indicates that only changed system pages within the LOB table space are to be cached to the group buffer pool. A system page is a space map page or any other page that does not contain actual data values.

NONE

Indicates that no pages are to be cached to the group buffer pool. Db2 uses the group buffer pool only for cross-invalidation.

LOCKMAX

Specifies the maximum number of locks an application process can hold simultaneously in the table space. If a program requests more than that number, locks are escalated. The locks are released and the intent lock on the table space is promoted to S or X mode.

integer

Specifies the number of locks allowed before escalating, in the range 0–2147483647.

Zero (0) indicates that the number of locks on the table space are not counted and escalation does not occur.

SYSTEM

FL 507 Specifies that Db2 determines the maximum number of locks that a program can hold simultaneously in the table space from the SYSIBMADM.MAX_LOCKS_PER_TABLESPACE built-in global variable.

For more information see [“MAX_LOCKS_PER_TABLESPACE” on page 331](#).

The following table summarizes the results of specifying a LOCKSIZE value while omitting LOCKMAX.

LOCKSIZE	Resultant LOCKMAX
ANY	SYSTEM
TABLESPACE, LOB	0

If the lock size is TABLESPACE, LOCKMAX must be omitted, or its value must be 0.

LOCKSIZE

Specifies the size of locks used within the table space and, in some cases, also the threshold at which lock escalation occurs.

ANY

Specifies that Db2 can use any lock size.

FL 507 In most cases, Db2 uses LOCKSIZE LOB LOCKMAX SYSTEM for LOB table spaces. However, when the number of locks acquired for the table space exceeds the maximum number of locks allowed for a table space (the value of the SYSIBMADM.MAX_LOCKS_PER_TABLESPACE built-in global variable), the LOB locks are released and locking is set at the next higher level. For more information, see [“MAX_LOCKS_PER_TABLESPACE” on page 331](#).

If the table space is implicitly created, Db2 uses LOCKSIZE ANY.

TABLESPACE

Specifies table space locks.

LOB

Specifies LOB locks.

LOGGED or NOT LOGGED

Specifies whether changes that are made to the data in the specified table space are recorded in the log. This setting applies to all indexes of the table. Auxiliary indexes inherit the logging attribute from the associated base table space.

LOGGED

Specifies that changes that are made to the data in the specified table space are recorded in the log.

LOGGED is the default.

NOT LOGGED

Specifies that changes that are made to data in the specified table space are not recorded in the log.

NOT LOGGED prevents undo and redo information from being recorded in the log; however, control information for the specified table space will continue to be recorded in the log.

USING block

If you omit USING, the default storage group of the database must exist. The USING clause indicates whether the data set for the table space is defined by you or by Db2. If Db2 is to define the data set, the clause also gives space allocation parameters and an erase rule.

If you omit USING, Db2 defines the data sets using the default storage group of the database and the defaults for PRIQTY, SECQTY, and ERASE.

VCAT *catalog-name*

Specifies that the first data set for the table space is managed by the user, and following data sets, if needed, are also managed by the user.

The data sets are VSAM linear data sets cataloged in the integrated catalog facility catalog that *catalog-name* identifies. For more information about *catalog-name* values, see [“Naming conventions in SQL”](#) on page 79.

More than one Db2 subsystem can share the integrated catalog facility catalogs with the current server. To avoid the chance of those subsystems attempting to assign the same name to different data sets, specify a *catalog-name* value that is not used by the other Db2 subsystems.

STOGROUP *stogroup-name*

Specifies that Db2 will define and manage the data sets for the table space. Each data set will be defined on a volume of the identified storage group. The values specified (or the defaults) for PRIQTY and SECQTY determine the primary and secondary allocations for the data set. The storage group supplies the name of a volume for the data set and the first-level qualifier for the data set name. The first-level qualifier is also the name of, or an alias³¹ for, the integrated catalog facility catalog on which the data set is to be cataloged. The naming conventions for the data set are the same as if the data set is managed by the user. As was mentioned above for VCAT, the first-level qualifier could cause naming conflicts if the local Db2 can share integrated catalog facility catalogs with other Db2 subsystems.

stogroup-name must identify a storage group that exists at the current server. SYSADM or SYSCtrl authority, or the USE privilege on the storage group, is required.

The description of the storage group must include at least one volume serial number, or it must indicate that the choice of volumes is left to Storage Management Subsystem (SMS). If volume serial numbers appear in the description, each must identify a volume that is accessible to z/OS for dynamic allocation of the data set, and all identified volumes must be of the same device type.

The integrated catalog facility catalog used for the storage group must not contain an entry for the first data set of the table space. If the integrated catalog facility catalog is password protected, the description of the storage group must include a valid password.

³¹ The alias of an integrated catalog facility catalog.

PRIQTY integer

Specifies the minimum primary space allocation for a Db2-managed data set. *integer* must be a positive integer, or -1. In general, when you specify PRIQTY with a positive integer value, the primary space allocation is at least *n* kilobytes, where *n* is the value of *integer*. However, the following exceptions exist:

- For 4KB page sizes, if *integer* is greater than 0 and less than 200, *n* is 200.
- For 8KB page sizes, if *integer* is greater than 0 and less than 400, *n* is 400.
- For 16KB page sizes, if *integer* is greater than 0 and less than 800, *n* is 800.
- For 32KB page sizes, if *integer* is greater than 0 and less than 1600, *n* is 1600.
- For any page size, if *integer* is greater than 67108864, *n* is 67108864.

If you do not specify PRIQTY, or specify PRIQTY with a value of -1, Db2 uses a default value for the primary space allocation; for information on how Db2 determines the default value, see [Rules for primary and secondary space allocation \(Introduction to Db2 for z/OS\)](#).

If you specify PRIQTY, and do not specify a value of -1, Db2 specifies the primary space allocation to access method services using the smallest multiple of *p* KB not less than *n*, where *p* is the page size of the table space. The allocated space can be greater than the amount of space requested by Db2. For example, it could be the smallest number of tracks that will accommodate the request. The amount of storage space requested must be available on some volume in the storage group based on VSAM space allocation restrictions. Otherwise, the primary space allocation will fail. To more closely estimate the actual amount of storage, see [DEFINE CLUSTER command \(DFSMS Access Method Services for Catalogs\)](#).

Executing this statement causes only one data set to be created. However, you might have more data than this one data set can hold. Db2 automatically defines more data sets when they are needed. Regardless of the value in PRIQTY, when a data set reaches its maximum size, Db2 creates a new one. To enable a data set to reach its maximum size without running out of extents, it is recommended that you allow Db2 to automatically choose the value of the secondary space allocations for extents.

If you do choose to explicitly specify SECQTY, to avoid wasting space, use the following formula to make sure that PRIQTY and its associated secondary extent values do not exceed the maximum size of the data set:

```
PRIQTY + (number of extents * SECQTY) <= DSSIZE (implicit or explicit)
```

SECQTY integer

Specifies the minimum secondary space allocation for a Db2-managed data set. *integer* must be a positive integer, 0, or -1. If you do not specify SECQTY, or specify SECQTY with a value of -1, Db2 uses a formula to determine a value. For information on the actual value that is used for secondary space allocation, whether you specify a value or not, see [Rules for primary and secondary space allocation \(Introduction to Db2 for z/OS\)](#).

If you specify SECQTY, and do not specify a value of -1, Db2 specifies the secondary space allocation to access method services using the smallest multiple of *p* KB not less than *integer*, where *p* is the page size of the table space. The allocated space can be greater than the amount of space requested by Db2. For example, it could be the smallest number of tracks that will accommodate the request. To more closely estimate the actual amount of storage, see [DEFINE CLUSTER command \(DFSMS Access Method Services for Catalogs\)](#).

ERASE

Indicates whether the Db2-managed data sets for the table space are to be erased when they are deleted during the execution of a utility or an SQL statement that drops the table space.

NO

Does not erase the data sets. Operations involving data set deletion will perform better than ERASE YES. However, the data is still accessible, though not through Db2. This is the default.

YES

Erases the data sets. As a security measure, Db2 overwrites all data in the data sets with zeros before they are deleted.

Notes for CREATE LOB TABLESPACE

Rules for primary and secondary space allocation

You can specify the primary and secondary space allocation or let Db2 choose them. Having Db2 choose the values, especially the secondary space quantity, increases the possibility of reaching the maximum data set size before running out of extents. For more information, see [Rules for primary and secondary space allocation \(Introduction to Db2 for z/OS\)](#).

Determining the number of LOB table spaces to create

For partitioned tables, each partition of the base table requires a separate LOB table space, auxiliary table, and auxiliary index for each LOB column.

Alternative syntax and synonyms

db2z_addpartition

For compatibility with previous Db2 releases or function levels, the following keywords are supported:

- When specifying the logging attributes for a table space, you can specify LOG YES as a synonym for LOGGED, and you can specify LOG NO as a synonym for NOT LOGGED.

Although these keywords are supported as alternatives, they are not the preferred syntax.

Example for CREATE LOB TABLESPACE

Assume that a column named EMP_PHOTO with a data type of BLOB(110K) has been added to the sample employee table for each employee's photo. Create LOB table space PHOTOLTS in database DSN8D12A for the auxiliary table that will hold the BLOB data.

Let Db2 define the data sets for the table space, using storage group DSN8G120. For each data set, the primary space allocation is 3200 kilobytes, and the secondary space allocation is 1600 kilobytes. The data sets do not need to be erased before they are deleted. (Because ERASE NO is the default, the clause does not have to be explicitly specified to get that behavior.)

```
CREATE LOB TABLESPACE PHOTOLTS
  IN DSN8D12A
  USING STOGROUP DSN8G120
  PRIQTY 3200
  SECQTY 1600
  LOCKSIZE LOB
  BUFFERPOOL BP16K0
  GBPCACHE SYSTEM
  NOT LOGGED
  CLOSE NO;
```

Related concepts

[LOB table spaces \(Db2 Administration Guide\)](#)

Related tasks

[Storing LOB data in Db2 tables \(Db2 Application programming and SQL\)](#)

[Creating large objects \(Introduction to Db2 for z/OS\)](#)

Related reference

[CREATE AUXILIARY TABLE statement](#)

The CREATE AUXILIARY TABLE statement creates an auxiliary table at the current server for storing LOB data.

CREATE MASK statement

The CREATE MASK statement creates a column mask at the current server. A *column mask* is used for column access control and specifies the value that should be returned for a specified column.

Invocation for CREATE MASK

This statement can be embedded in an application program or issued interactively. It is an executable statement that can be dynamically prepared only if DYNAMICRULES RUN behavior is in effect. For more information, see [“Authorization IDs and dynamic SQL”](#) on page 94.

Authorization for CREATE MASK

The privilege set that is defined below must include the following authority:

SECADM authority

SECADM authority can create a column mask in any schema. Additional privileges are not needed to reference other objects in the mask definition. For example, the SELECT privilege is not needed query a table, and the EXECUTE privilege is not needed to invoke a user-defined function.

Privilege set: If the statement is embedded in an application program, the privilege set is the set of privileges that are held by the owner of the package. If the statement is dynamically prepared, the privilege set is the set of privileges that are held by the SQL authorization ID of the process. However, if the process is running in a trusted context that is defined with the ROLE AS OBJECT OWNER AND QUALIFIER clause, the privilege set is the set of privileges that are held by the role that is in effect.

Syntax for CREATE MASK

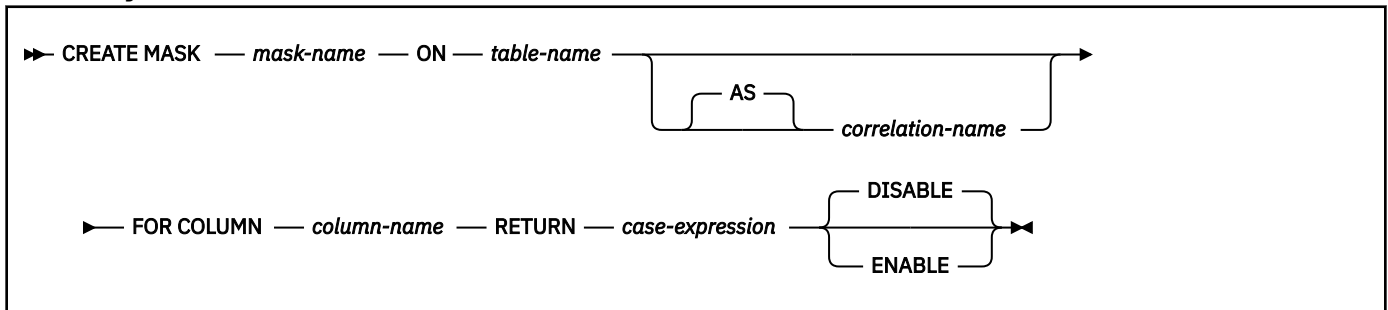

Description for CREATE MASK

mask-name

Specifies the names the column mask. The name, including the implicit or explicit qualifier, must not identify a column mask or a row permission that already exists at the current server.

ON table-name

Identifies the table for which the column mask is created. The name must identify a table that exists at the current server. It must not identify any of the following objects:

- An auxiliary table
- A created or declared temporary table
- A view
- A catalog table
- An alias
- A synonym

- A materialized query table or table that is directly or indirectly referenced in the definition of a materialized query table
- A table that was implicitly created for an XML column
- A table that contains a period
- A history table
- An accelerator-only table
- An archive-enabled table
- An archive table

correlation-name

Specifies a correlation name that can be used within *case-expression* to designate the table. For information about *correlation-name*, see [“Correlation names” on page 220](#).

FOR COLUMN *column-name*

Identifies the column to which the mask applies. *column-name* must be an unqualified name that identifies a column of the specified table. A mask must not already exist for the column. The column must not be:

- a LOB column or a distinct type column that is based on a LOB
- an XML column
- defined with a FIELDPROC

RETURN *case-expression*

Specifies a CASE expression that determines the value that is returned for the column. The result of the CASE expression is returned in place of the column value in a row. The result data type, null attribute, data length, subtype, encoding scheme, and CCSID of the CASE expression must be identical to those attributes of the column that is specified by *column-name*. If the data type of *column-name* is a user-defined data type, the result data type of the CASE expression must be the same user-defined type. The CASE expression must not reference any of the following objects:

- A remote object
- The table for which the column mask is being defined
- A created global temporary table or a declared global temporary table
- An auxiliary table
- A table that was implicitly created for an XML column
- A column that is defined with a FIELDPROC
- A LOB column or a distinct type column that is based on a LOB
- An XML column
- A select list notation *** or *name . ** in the SELECT clause
- A table function
- A collection-derived table (UNNEST)
- A user-defined function that is defined as not secure
- A function that is not deterministic or that has an external action or is defined with the MODIFIES SQL DATA option
- An aggregate function, unless it is specified in a subquery
- A built-in table function
- An XMLTABLE table function
- An XMLEXISTS predicate
- An OLAP specification
- A ROW CHANGE expression
- A sequence reference

- A host variable, SQL variable, SQL parameter, or trigger transition variable
- A parameter marker
- A table reference that contains a period specification
- A view that includes any of the preceding restrictions in its definition
- An accelerator-only table

The encoding scheme of the table is used to evaluate the CASE expression. Tables and language elements that require multiple encoding scheme evaluation, other than EBCDIC tables with Unicode columns, must not be referenced in the CASE expression. See [Determining the encoding scheme and CCSID of a string \(Introduction to Db2 for z/OS\)](#) for language elements that require multiple evaluation.

If the CASE expression references tables for which row or column access control is active, access controls for those tables are not cascaded.

DISABLE or ENABLE

Specifies that the column mask is to be enabled or disabled for column access control.

DISABLE

Specifies that the column mask is to be disabled for column access control. The column mask will remain disabled regardless of whether column access control is activated for the table.

DISABLE is the default.

ENABLE

Specifies that the column mask is to be enabled for column access control. If column access control is not currently active for the table, the column mask will become enabled when column access control is activated for the table. If column access control is currently active for the table, the column mask becomes enabled immediately and all packages and statements in the dynamic statement cache that reference the table are invalidated. For more information, see [Changes that invalidate packages \(Db2 Application programming and SQL\)](#).

Notes for CREATE MASK

How column masks affect queries:

The application of enabled column masks does not interfere with the operations of other clauses within the statement such as the WHERE, GROUP BY, HAVING, SELECT DISTINCT, or ORDER BY. The rows that are returned in the final result table remain the same, except that the values in the resulting rows might have been masked by the column masks. As such, if the masked column also appears in an ORDER BY clause with a *sort-key* expression, the order is based on the original values of the column and the masked values in the final result table might not reflect that order. Similarly, the masked values might not reflect the uniqueness enforced by a SELECT DISTINCT statement. If the masked column is embedded in an expression, the result of the expression might become different because the column mask is applied on the column before the expression evaluation can take place. For example, a column mask on column SSN might change the result of the aggregate function COUNT(DISTINCT SSN) because the DISTINCT operation is performed on the unmasked values.

Conflicts between the definition of a column mask and SQL:

A column mask is created as a stand alone object, without knowing all of the contexts in which it might be used. To mask the value of a column in the final result table, the definition of the column mask is merged into a query by Db2. When the definition of the column mask is brought into the context of the statement, it might conflict with certain SQL semantics in the statement. Therefore, in some situations, the combination of the statement and the application of the column mask can return an error. When this happens, either the statement needs to be modified or the column mask must be dropped or re-created with a different definition. See [“ALTER TABLE statement” on page 1232](#) for those situations in which a bind time error might be issued for the statement.

Column masks and null columns:

If the column is not nullable, the definition of its column mask will not, most likely, consider a null value for the column. After the column access control is activated for the table, if the table is the

null-padded table in an outer join, the value of the column in the final result table might be a null. To ensure that the column mask can mask a null value, if the table is the null-padded table in an outer join, Db2 will add "WHEN *target-column* IS NULL THEN NULL" as the first WHEN clause to the column mask definition. This forces a null value to always be masked as a null value. For a nullable column, this removes the ability to mask a null value as something else. Example 5 shows this added WHEN clause.

Column mask values for SQL data change statements

When columns are used to derive new values for an INSERT, UPDATE, MERGE, or a SET *transition-variable* assignment statement, the original values of the column, not the masked values, are used to derive the new values. If the columns have column masks, those column masks are applied to ensure that the evaluation of the access control rules at run time masks the column to itself, not to a constant or an expression. This is to ensure that the masked values are the same as the original column values. If a column mask does not mask the column to itself, the existing row is not updated or the new row is not inserted and an error is returned at run time. The rules that are used to apply column masks in order to derive the new values follow the same rules for the final result table of a query.

Column masks that are created before column access control is activated:

The CREATE MASK statement is an independent statement that can be used to create a column access control mask before column access control is activated for a table. The only requirement is that the table and the columns exist before the mask is created. Multiple column masks can be created for a table but a column can have one mask only.

The definition of a mask is stored in the Db2 catalog. Dependency on the table for which the mask is being created and dependencies on other objects referenced in the definition are recorded. No package or dynamic cached statement is invalidated. A column mask can be created as enabled or disabled for column access control. An enabled column mask does not take effect until the ALTER TABLE statement with the ACTIVATE COLUMN ACCESS CONTROL clause is used to activate column access control for the table. SECADM authority is required to issue such an ALTER TABLE statement. A disabled column mask remains ineffective even when column access control is activated for the table. The ALTER MASK statement can be used to alter between ENABLE and DISABLE.

After column access control is activated for a table, when the table is referenced in a data manipulation statement, all enabled column masks that have been created for the table are implicitly applied by Db2 to mask the values returned for the columns referenced in the final result table of the queries or to determine the new values used in the data change statements.

Tip: To avoid multiple invalidations of packages and dynamic cached statements that reference the table, creating column masks before activating column access control for a table .

Column masks that are created after column access control is activated:

The enabled column masks become effective as soon as they are committed. All the packages and dynamic cached statements that reference the table are invalidated. Thereafter, when the table is referenced in a data manipulation statement, all enabled column masks are implicitly applied by Db2 to the statement. Any disabled column mask remains ineffective even when column access control is activated for the table.

No cascaded effect when column or row access control enforced tables are referenced in column mask definitions:

A column mask definition may reference tables and columns that are currently enforced by row or column access control. Access control from those tables and columns are ignored when the table for which the column mask is being created is referenced in a data manipulation statement.

Multiple column masks and row permissions sharing the same environment variables:

Multiple column masks and row permissions can be created for a table. They must use the same set of environment variables. The set of environment variables is determined when the first column mask or row permission is created for the table.

The catalog table SYSENVIRONMENT contains the list of environment variables. The following table shows which environment variable must be the same among the multiple column masks and row permissions.

Table 202. Environment Variables in SYSIBM.SYSENVIRONMENT

Environment variables shown as SYSENVIRONMENT columns	Description	Static create statement	Dynamic create statement	Must be the same among multiple column masks and row permissions?
ENVID	Internal identifier of the environment	Assigned by Db2	Assigned by Db2	Yes
CURRENT_SCHEMA	The qualifier used to qualify unqualified objects such as tables, views. etc.	Package owner	Value of CURRENT_SCHEMA special register	Yes
PATHSCHEMAS	The schema path used to qualify unqualified object such as user-defined functions and CAST functions for user-defined data types.	PATH bind option	Value of CURRENT_PATH special register	Yes
APPLICATION_ENCODING_CCSID	The CCSID of the application environment	ENCODING bind option	CURRENT APPLICATION ENCODING SCHEME special register	Yes
ORIGINAL_ENCODING_CCSID	The original CCSID of the statement text string	CCSID(n) pre-compiler option or EBCDIC CCSID on DSNTIPF installation panel	CCSID based on DEF ENCODING SCHEME on DSNTIPF installation panel	Yes
DECIMAL_POINT	The decimal point indicator	COMMA or PERIOD precompiler option or DECIMAL POINT IS on DSNTIPF installation panel	DECIMAL POINT IS on DSNTIPF installation panel	Yes
MIN_DIVIDE_SCALE	The minimum divide scale	MINIMUM DIVIDE SCALE on DSNTIP4 installation panel	MINIMUM DIVIDE SCALE on DSNTIP4 installation panel	Yesv
STRING_DELIMITER	The string delimiter that is used in COBOL string constants	APOST precompiler option or STRING DELIMITER on DSNTIPF installation panel	STRING DELIMITER on DSNTIPF installation panel	No
SQL_STRING_DELIMITER	The SQL string delimiter that is used in constants	APOSTSQL pre-compiler option or SQL STRING DELIMITER on DSNTIPF installation panel	SQL STRING DELIMITER on DSNTIPF installation panel	Yes
MIXED_DATA	Uses mixed DBCS data	MIXED DATA on DSNTIPF installation panel	MIXED DATA on DSNTIPF installation panel	Yes

Table 202. Environment Variables in SYSIBM.SYSENVIRONMENT (continued)

Environment variables shown as SYSENVIRONMENT columns	Description	Static create statement	Dynamic create statement	Must be the same among multiple column masks and row permissions?
DECIMAL_ARITHMETIC	The rules that are to be used for CURRENT PRECISION and when both operands in a decimal operation have a precision of 15 or less.	DEC(15) or DEC(31) precompiler option or DECIMAL ARITHMETIC on DSNTIP4 installation panel	DECIMAL ARITHMETIC on DSNTIP4 installation panel	Yes
DATE_FORMAT	The date format	DATE pre-compiler option or DATE FORMAT on DSNTIP4 installation panel	DATE FORMAT on DSNTIP4 installation panel	Yes
TIME_FORMAT	The time format	TIME pre-compiler option or TIME FORMAT on DSNTIP4 installation panel	TIME FORMAT on DSNTIP4 installation panel	Yes
FLOAT_FORMAT	The floating point format	FLOAT (S390 IEEE) pre-compiler option or default of FLOAT S390	Default of FLOAT S390	No
HOST_LANGUAGE	The host language	HOST pre-compiler option or LANGUAGE DEFAULT on DSNTIPF installation panel	LANGUAGE DEFAULT on DSNTIPF installation panel	No
CHARSET	The character set	CCSID(n) pre-compiler option or EBCDIC CCSID on DSNTIPF installation panel	EBCDIC CCSID on DSNTIPF installation panel	No
FOLD	FOLD is only applicable when HOST_LANGUAGE is C or CPP. Otherwise FOLD is blank.	HOST(C(FOL D) precompiler option or default of NO FOLD	default of NO FOLD	No
ROUNDING	The rounding mode that is used when arithmetic and casting operations are performed on DECFLOAT data.	ROUNDING bind option	CURRENT DECFLOAT ROUNDING MODE special register	Yes

Table 202. Environment Variables in SYSIBM.SYSENVIRONMENT (continued)

Environment variables shown as SYSENVIRONMENT columns	Description	Static create statement	Dynamic create statement	Must be the same among multiple column masks and row permissions?
<p>Note: In a data sharing environment, if a separate DSNHDECP module is provided for each member of the group, the DSNHDECP settings for each environment variable should be the same in all members of the data sharing group, otherwise an error might be issued when multiple column masks or row permissions are created.</p>				

Ordinary SQL identifiers specified in a static CREATE MASK statement in a COBOL application:

If the CREATE MASK statement is a static statement in a COBOL application, the ordinary SQL identifiers used in the column mask definition must not follow the rules for naming COBOL words. They must follow the rules for naming “Identifiers in SQL” on page 77. For example, the COBOL word 1ST-TIME is not allowed as an ordinary SQL identifier in a column mask definition; change it to FIRST_TIME or put it in the delimiters.

Encoding scheme and CCSIDs of the data manipulation statement after column masks are applied:

The encoding scheme and CCSIDs of the data manipulation statement are not affected by the column masks that are implicitly applied by Db2 for the column access control. For a target table or a referenced table that is not an EBCDIC table with Unicode columns, the column mask definition is evaluated using its table's encoding scheme and CCSIDs. For a target table or a referenced table that is an EBCDIC table with Unicode columns, the column mask definition is evaluated using the rules for multiple encoding schemes.

Consideration for Db2 limits:

If the data manipulation statement already approaches some Db2 limits in the statement, it should be noted that the more enabled column masks and enabled row permissions are created, the more likely they would impact some limits. For example, they may cause the statement to exceed the maximum total length (32600 bytes) of columns of a query operation requiring sort and evaluating aggregate functions (MULTIPLE DISTINCT and GROUP BY). This is because the enabled column mask and enabled row permission definitions are implicitly merged into the statement when the table is referenced in a data manipulation statement. See "Limits in Db2 for z/OS" in SQL Reference for the limits of a statement.

Restrictions involving pending definition changes:

CREATE MASK is not allowed if the mask is defined on a table or references a table that has pending definition changes.

Examples for CREATE MASK

In the following examples, the data type of column SSN is VARCHAR(11).

Example 1

After column access control is activated for table EMPLOYEE, Paul from the payroll department can see the social security number of the employee whose employee number is 123456. Mary who is a manager can see the last four characters only of the social security number. Peter who is neither cannot see the social security number.

```
CREATE MASK SSN_MASK ON EMPLOYEE
FOR COLUMN SSN RETURN
CASE
  WHEN (VERIFY_GROUP_FOR_USER(SESSION_USER, 'PAYROLL') = 1)
    THEN SSN
  WHEN (VERIFY_GROUP_FOR_USER(SESSION_USER, 'MGR') = 1)
    THEN 'XXX-XX-' || SUBSTR(SSN,8,4)
  ELSE NULL
END
ENABLE;
```

```

COMMIT;

ALTER TABLE EMPLOYEE
  ACTIVATE COLUMN ACCESS CONTROL;

COMMIT;

SELECT SSN FROM EMPLOYEE
  WHERE EMPNO = 123456;

```

Example 2

In the SELECT statement, column SSN is embedded in an expression that is the same as the expression used in the column mask SSN_MASK. After column access control is activated for table EMPLOYEE, the column mask SSN_MASK is applied to column SSN in the SELECT statement. For this particular expression, the SELECT statement produces the same result as before column access control is activated for all users. The user can replace the expression in the SELECT statement with column SSN to avoid the same expression gets evaluated twice.

```

CREATE MASK SSN_MASK ON EMPLOYEE
  FOR COLUMN SSN RETURN
  CASE
    WHEN (1 = 1)
      THEN 'XXX-XX-' || SUBSTR(SSN,8,4)
    ELSE NULL
  END
  ENABLE;

COMMIT;

ALTER TABLE EMPLOYEE
  ACTIVATE COLUMN ACCESS CONTROL;

COMMIT;

SELECT 'XXX-XX-' || SUBSTR(SSN,8,4) FROM EMPLOYEE
  WHERE EMPNO = 123456;

```

Example 3

A state government conducted a survey for the library usage of the households in each city. Fifty households in each city were sampled in the survey. Each household was given an option, opt-in or opt-out, whether to show their usage in any reports generated from the result of the survey.

A SELECT statement is used to generate a report to show the average hours used by households in each city. Column mask CITY_MASK is created to mask the city name based on the opt-in or opt-out information chosen by the sampled households. However, after column access control is activated for table LIBRARY_USAGE, the SELECT statement receives a bind time error. This is because column mask CITY_MASK references another column LIBRARY_OPT and LIBRARY_OPT does not identify a grouping column.

```

CREATE MASK CITY_MASK ON LIBRARY_USAGE
  FOR COLUMN CITY RETURN
  CASE
    WHEN (LIBRARY_OPT = 'OPT-IN')
      THEN CITY
    ELSE ' '
  END
  ENABLE;

COMMIT;

ALTER TABLE LIBRARY_USAGE
  ACTIVATE COLUMN ACCESS CONTROL;

COMMIT;

SELECT CITY, AVG(LIBRARY_TIME) FROM LIBRARY_USAGE
  GROUP BY CITY;

```

Example 4

Employee with EMPNO 123456 earns bonus \$8000 and salary \$80000 in May. When the manager retrieves his salary, the manager receives his salary, not the null value. This is because of no

cascaded effect when column mask SALARY_MASK references column BONUS for which column mask BONUS_MASK is defined.

```
CREATE MASK SALARY_MASK ON EMPLOYEE
FOR COLUMN SALARY RETURN
CASE
    WHEN (BONUS < 10000)
    THEN SALARY
    ELSE NULL
END
ENABLE;

COMMIT;

CREATE MASK BONUS_MASK ON EMPLOYEE
FOR COLUMN BONUS RETURN
CASE
    WHEN (BONUS > 5000)
    THEN NULL
    ELSE BONUS
END
ENABLE;

COMMIT;

ALTER TABLE EMPLOYEE
ACTIVATE COLUMN ACCESS CONTROL;

COMMIT;

SELECT SALARY FROM EMPLOYEE
WHERE EMPNO = 123456;
```

Example 5

This example shows Db2 adds "WHEN target-column IS NULL THEN NULL" as the first WHEN clause to the column mask definition then merges the column mask definition into the statement.

```
CREATE EMPLOYEE (EMPID INT,
                DEPTID CHAR(8),
                SALARY DEC(9,2) NOT NULL,
                BONUS DEC(9,2));

CREATE MASK SALARY_MASK ON EMPLOYEE
FOR COLUMN SALARY RETURN
CASE
    WHEN SALARY < 10000
    THEN CAST(SALARY*2 AS DEC(9,2))
    ELSE COALESCE(CAST(SALARY/2 AS DEC(9,2)), BONUS)
END
ENABLE;

COMMIT;

CREATE MASK BONUS_MASK ON EMPLOYEE
FOR COLUMN BONUS RETURN
CASE
    WHEN BONUS > 1000
    THEN BONUS
    ELSE NULL
END
ENABLE;

COMMIT;

ALTER TABLE EMPLOYEE
ACTIVATE COLUMN ACCESS CONTROL;

COMMIT;

SELECT SALARY FROM DEPT
LEFT JOIN EMPLOYEE ON DEPTNO = DEPTID;

/* When SALARY_MASK is merged into the above statement,
 * 'WHEN SALARY IS NULL THEN NULL' is added as the
 * first WHEN clause, as follows:
 */

SELECT CASE WHEN SALARY IS NULL THEN NULL
           WHEN SALARY < 10000 THEN CAST(SALARY*2 AS DEC(9,2))
```

```

ELSE COALESCE(CAST(SALARY/2 AS DEC(9,2)), BONUS)
END SALARY
FROM DEPT
LEFT JOIN EMPLOYEE ON DEPTNO = DEPTID;

```

Related concepts

[Column mask \(Managing Security\)](#)

[Naming conventions](#)

The rules for forming a name depend on the type of the object designated by the name.

Related tasks

[Creating column masks \(Managing Security\)](#)

CREATE PERMISSION statement

The CREATE PERMISSION statement creates a row permission for row access control at the current server.

Invocation for CREATE PERMISSION

This statement can be embedded in an application program or issued interactively. It is an executable statement that can be dynamically prepared only if DYNAMICRULES RUN behavior is in effect. For more information, see [“Authorization IDs and dynamic SQL” on page 94](#).

Authorization for CREATE PERMISSION

The privilege set that is defined below must include the following authority:

- SECADM authority

SECADM authority can create a row permission in any schema. Additional privileges are not needed to reference other objects in the permission definition. For example, the SELECT privilege is not needed to retrieve from a table, and the EXECUTE privilege is not needed to invoke a user-defined function.

Privilege set: If the statement is embedded in an application program, the privilege set is the privileges that are held by the owner of the package. If the statement is dynamically prepared, the privilege set is the set of privileges that are held by the SQL authorization ID of the process. However, if it is running in a trusted context defined with the ROLE AS OBJECT OWNER AND QUALIFIER clause, the privilege set is the set of privileges that are held by the role in effect.

Syntax for CREATE PERMISSION

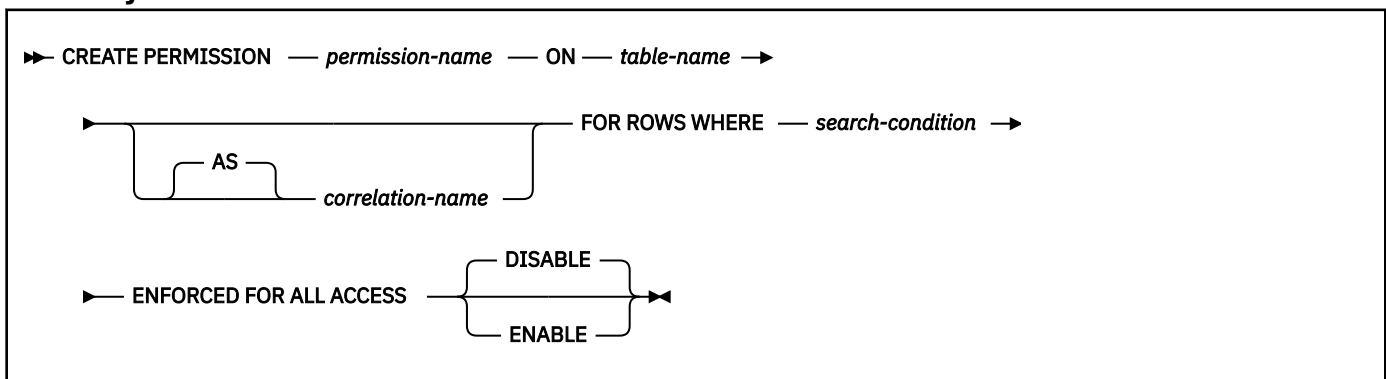

Description for CREATE PERMISSION

permission-name

Names the row permission for row access control. The name, including the implicit or explicit qualifier, must not identify a row permission or a column mask that already exists at the current server

ON *table-name*

Identifies the table on which the row permission is created. The name must identify a table that exists at the current server. It must not identify any of the following objects:

- An auxiliary table
- A created or declared temporary table
- A view
- A catalog table
- An alias
- A synonym
- A materialized query table or table that is directly or indirectly referenced in the definition of a materialized query table
- A table that was implicitly created for an XML column
- A table that contains a period
- A history table
- An accelerator-only table
- An archive-enabled table
- An archive table
- A table that has a security label column.

correlation-name

Can be used within *search-condition* to designate the table. For the explanation of *correlation-name*, see [“Correlation names” on page 220](#).

FOR ROWS WHERE

Indicates that a row permission is created. A row permission specifies a search condition under which rows of the table can be accessed.

search-condition

Specifies a condition that can be true, false, or unknown for a row of the table. *search-condition* follows the same rules that are used by the search condition in a WHERE clause of a subselect. In addition, the search condition must not reference any of the following objects:

- A remote object
- The table for which the row permission is being defined
- A table that has a security label column
- A created global temporary table or a declared global temporary table
- An auxiliary table
- A table that was implicitly created for an XML column
- A collection-derived table (UNNEST)
- A table function
- A host variable, SQL variable, SQL parameter, or trigger transition variable
- A user-defined function that is defined as not secure
- A function that is not deterministic or that has an external action or is defined with the MODIFIES SQL DATA option
- A parameter marker
- A column that is defined with a FIELDPROC
- A LOB column or a distinct type column that is based on a LOB
- An XML column
- An XMLEXISTS predicate
- An OLAP specification

- A ROW CHANGE expression
- A sequence reference
- A select list notation * or *name* . * in the SELECT clause
- A table reference that contains a period specification
- A view that includes any of the preceding restrictions in its definition

The encoding scheme of the table is used to evaluate the *search-condition*. Tables and language elements that require multiple encoding scheme evaluation, other than EBCDIC tables with Unicode columns, must not be referenced in the *search-condition*. See [Determining the encoding scheme and CCSID of a string \(Introduction to Db2 for z/OS\)](#) for those language elements.

If the *search-condition* references tables for which row or column access control is activated, access control from those tables is not cascaded.

ENFORCED FOR ALL ACCESS

Specifies that the row permission applies to all references of the table. If row access control is activated for the table, when the table is referenced in a data manipulation statement, Db2 implicitly applies the row permission to control the access of the table. If the reference of the table is for a fetch operation such as SELECT, the application of the row permission determines what set of rows can be retrieved by the user who requested the fetch operation. If the reference of the table is for a data change operation such as INSERT, the application of the row permission determines whether all rows to be changed are insertable or updatable by the user who requested the data change operation.

DISABLE or ENABLE

Specifies that the row permission is to be enabled or disabled for row access control.

DISABLE

Specifies that the row permission is to be disabled for row access control. The row permission will remain ineffective regardless the row access control is activated for the table or not.

DISABLE is the default.

ENABLE

Specifies that the row permission is to be enabled for row access control. If row access control is not currently activated for the table, the row permission will become effective when row access control is activated for the table. If row access control is currently activated for the table, the row permission becomes effective immediately and all packages and dynamic cached statements that reference the table are invalidated. For more information, see [Changes that invalidate packages \(Db2 Application programming and SQL\)](#).

Notes for CREATE PERMISSION

How row permission are applied and how they affect certain statements:

See the ALTER TABLE statement with the ACTIVATE ROW ACCESS CONTROL clause for information on how to activate row access control and how row permissions are applied. See the description of subselect for information on how the application of row permissions affects the fetch operation. See the data change statements for information on how the application of row permissions affects the data change operation.

Row permissions that are created before row access control is activated for a table:

The CREATE PERMISSION statement is an independent statement that can be used to create a row permission before row access control is activated for a table. The only requirement is that the table and the columns exist before the permission is created. Multiple row permissions can be created for a table.

The definition of the row permission is stored in the Db2 catalog. Dependency on the table for which the permission is being created and dependencies on other objects referenced in the definition are recorded. No package or dynamic cached statement is invalidated. A row permission can be created as enabled or disabled for row access control. An enabled row permission does not take effect until the ALTER TABLE statement with the ACTIVATE ROW ACCESS CONTROL clause is used to activate row access control for the table. A disabled row permission remains ineffective even when row access

control is activated for the table. The ALTER PERMISSION statement can be used to alter between ENABLE and DISABLE.

After row access control is activated for a table, when the table is referenced in a data manipulation statement, all enabled row permissions that are defined for the table are implicitly applied by Db2 to control access to the table.

Tip: Create row permissions before activating row access control for a table to avoid multiple invalidations of packages and dynamic cached statements that reference the table.

Row permissions that are created after row access control is activated for a table:

An enabled row permission becomes effective as soon as it is committed. All the packages and dynamic cached statements that reference the table are invalidated. Thereafter, when the table is referenced in a data manipulation statement, all enabled row permissions are implicitly applied to the statement. Any disabled row permission remains ineffective even when row access control is activated for the table.

No cascaded effect when row or column access control enforced tables are referenced in row permission definitions:

A row permission definition may reference tables and columns that are currently enforced by row or column access control. Access control from those tables are ignored when the table for which the row permission is being created is referenced in a data manipulation statement.

Multiple column masks and row permissions sharing the same environment variables:

Multiple column masks and row permissions can be created for a table. They must use the same set of environment variables. The set of environment variables is determined when the first column mask or row permission is created for the table.

The catalog table SYSENVIRONMENT contains the list of environment variables. The following table shows which environment variable must be the same among the multiple column masks and row permissions.

Table 203. Environment Variables in SYSIBM.SYSENVIRONMENT

Environment variables shown as SYSENVIRONMENT columns	Description	Static create statement	Dynamic create statement	Must be the same among multiple column masks and row permissions?
ENVID	Internal identifier of the environment	Assigned by Db2	Assigned by Db2	Yes
CURRENT_SCHEMA	The qualifier used to qualify unqualified objects such as tables, views. etc.	Package owner	Value of CURRENT_SCHEMA special register	Yes
PATHSCHEMAS	The schema path used to qualify unqualified object such as user-defined functions and CAST functions for user-defined data types.	PATH bind option	Value of CURRENT_PATH special register	Yes
APPLICATION_ENCODING_CCSID	The CCSID of the application environment	ENCODING bind option	CURRENT APPLICATION_ENCODING_SCHEME special register	Yes

Table 203. Environment Variables in SYSIBM.SYSENVIRONMENT (continued)

Environment variables shown as SYSENVIRONMENT columns	Description	Static create statement	Dynamic create statement	Must be the same among multiple column masks and row permissions?
ORIGINAL_ENCODING_CCSID	The original CCSID of the statement text string	CCSID(n) pre-compiler option or EBCDIC CCSID on DSNTIPF installation panel	CCSID based on DEF ENCODING SCHEME on DSNTIPF installation panel	Yes
DECIMAL_POINT	The decimal point indicator	COMMA or PERIOD precompiler option or DECIMAL POINT IS on DSNTIPF installation panel	DECIMAL POINT IS on DSNTIPF installation panel	Yes
MIN_DIVIDE_SCALE	The minimum divide scale	MINIMUM DIVIDE SCALE on DSNTIP4 installation panel	MINIMUM DIVIDE SCALE on DSNTIP4 installation panel	Yesv
STRING_DELIMITER	The string delimiter that is used in COBOL string constants	APOST precompiler option or STRING DELIMITER on DSNTIPF installation panel	STRING DELIMITER on DSNTIPF installation panel	No
SQL_STRING_DELIMITER	The SQL string delimiter that is used in constants	APOSTSQL pre-compiler option or SQL STRING DELIMITER on DSNTIPF installation panel	SQL STRING DELIMITER on DSNTIPF installation panel	Yes
MIXED_DATA	Uses mixed DBCS data	MIXED DATA on DSNTIPF installation panel	MIXED DATA on DSNTIPF installation panel	Yes
DECIMAL_ARITHMETIC	The rules that are to be used for CURRENT PRECISION and when both operands in a decimal operation have a precision of 15 or less.	DEC(15) or DEC(31) precompiler option or DECIMAL ARITHMETIC on DSNTIP4 installation panel	DECIMAL ARITHMETIC on DSNTIP4 installation panel	Yes
DATE_FORMAT	The date format	DATE pre-compiler option or DATE FORMAT on DSNTIP4 installation panel	DATE FORMAT on DSNTIP4 installation panel	Yes
TIME_FORMAT	The time format	TIME pre-compiler option or TIME FORMAT on DSNTIP4 installation panel	TIME FORMAT on DSNTIP4 installation panel	Yes

Table 203. Environment Variables in SYSIBM.SYSENVIRONMENT (continued)

Environment variables shown as SYSENVIRONMENT columns	Description	Static create statement	Dynamic create statement	Must be the same among multiple column masks and row permissions?
FLOAT_FORMAT	The floating point format	FLOAT (S390 IEEE) pre-compiler option or default of FLOAT S390	Default of FLOAT S390	No
HOST_LANGUAGE	The host language	HOST pre-compiler option or LANGUAGE DEFAULT on DSNTIPF installation panel	LANGUAGE DEFAULT on DSNTIPF installation panel	No
CHARSET	The character set	CCSID(n) pre-compiler option or EBCDIC CCSID on DSNTIPF installation panel	EBCDIC CCSID on DSNTIPF installation panel	No
FOLD	FOLD is only applicable when HOST_LANGUAGE is C or CPP. Otherwise FOLD is blank.	HOST(C(FOL D) precompiler option or default of NO FOLD	default of NO FOLD	No
ROUNDING	The rounding mode that is used when arithmetic and casting operations are performed on DECFLOAT data.	ROUNDING bind option	CURRENT DECFLOAT ROUNDING MODE special register	Yes

Note: In a data sharing environment, if a separate DSNHDECP module is provided for each member of the group, the DSNHDECP settings for each environment variable should be the same in all members of the data sharing group, otherwise an error might be issued when multiple column masks or row permissions are created.

Ordinary SQL identifiers specified in a static CREATE PERMISSION statement in a COBOL application:

If the CREATE PERMISSION statement is a static statement in a COBOL application, the ordinary SQL identifiers used in the row permission definition must not follow the rules for naming COBOL words (DSNH20474, reason code 14). They must follow the rules for naming SQL identifiers as described in the topic “SQL identifiers” in Db2 SQL Reference. For example, the COBOL word 1ST-TIME is not allowed as an ordinary SQL identifier in a row permission definition; change it to FIRST_TIME or put it in the delimiters.

Encoding scheme and CCSIDs of the data manipulation statement after row permissions are applied:

The encoding scheme and CCSIDs of the data manipulation statement are not affected by the row permissions that are implicitly applied by Db2 for the row access control. For a target table or a referenced table that is not an EBCDIC table with Unicode columns, the row permission definition is evaluated using its table's encoding scheme and CCSIDs. For a target table or a referenced table that is an EBCDIC table with Unicode columns, the row permission definition is evaluated using the rules for multiple encoding schemes.

Consideration for Db2 limits:

If the data manipulation statement already approaches some Db2 limits in the statement, it should be noted that the more enabled row permissions and enabled column masks are created, the more likely they would impact some limits. For example, they may cause the statement to exceed the maximum total length (32600 bytes) of columns of a query operation requiring sort and evaluating aggregate functions (MULTIPLE DISTINCT and GROUP BY). This is because the enabled column mask and enabled row permission definitions are implicitly merged into the statement when the table is referenced in a data manipulation statement. See "Limits in Db2 for z/OS" in SQL Reference for the limits of a statement.

Restrictions involving pending definition changes:

CREATE PERMISSION is not allowed if the permission is defined on a table or references a table that has pending definition changes.

Examples for CREATE PERMISSION

Example 1

Secure user-defined function ACCOUNTING_UDF in row permission SALARY_ROW_ACCESS processes the sensitive data in column SALARY. After row access control is activated for table EMPLOYEE, Accountant Paul retrieves the salary of employee with EMPNO 123456 who is making \$100,000 a year. Paul may or may not see the row depending on the output value from user-defined function ACCOUNTING_UDF.

```
CREATE PERMISSION SALARY_ROW_ACCESS ON EMPLOYEE
  FOR ROWS WHERE VERIFY_GROUP_FOR_USER(SESSION_USER, 'MGR', 'ACCOUNTING') = 1
              AND
              ACCOUNTING_UDF(SALARY) < 120000
  ENFORCED FOR ALL ACCESS
  ENABLE;

COMMIT;

ALTER TABLE EMPLOYEE
  ACTIVATE ROW ACCESS CONTROL;

COMMIT;

SELECT SALARY FROM EMPLOYEE
  WHERE EMPNO = 123456;
```

Example 2

The tellers in a bank can only access customers from their branch. All tellers have secondary authorization ID TELLER. The customer service representatives are allowed to access all customers of the bank. All customer service representatives have secondary authorization ID CSR. A row permission is created for each group of personnel in the bank accordingly to the access rule defined by SECADM authority. After row access control is activated for table CUSTOMER, in the SELECT statement the search conditions of both row permissions are merged into the statement and they are combined with the logic OR operator to control the set of rows accessible by each group.

```
CREATE PERMISSION TELLER_ROW_ACCESS ON CUSTOMER
  FOR ROWS WHERE VERIFY_GROUP_FOR_USER(SESSION_USER, 'TELLER') = 1
              AND
              BRANCH = (SELECT HOME_BRANCH FROM INTERNAL_INFO
                       WHERE EMP_ID = SESSION_USER)
  ENFORCED FOR ALL ACCESS
  ENABLE;

COMMIT;

CREATE PERMISSION CSR_ROW_ACCESS ON CUSTOMER
  FOR ROWS WHERE VERIFY_GROUP_FOR_USER(SESSION_USER, 'CSR') = 1
  ENFORCED FOR ALL ACCESS
  ENABLE;

COMMIT;

ALTER TABLE CUSTOMER
  ACTIVATE ROW ACCESS CONTROL;
```

```
COMMIT;  
SELECT * FROM CUSTOMER;
```

Related concepts

[Row permission \(Managing Security\)](#)

[Naming conventions](#)

The rules for forming a name depend on the type of the object designated by the name.

Related tasks

[Creating row permissions \(Managing Security\)](#)

CREATE PROCEDURE statement (overview)

The CREATE PROCEDURE statement registers a stored procedure with a database server. You can register the following types of procedures with this statement, each of which is described separately.

You can create the following types of stored procedures:

Native SQL procedures

The procedure body is written exclusively in SQL statements, including SQL procedural language (SQL PL) statements. The procedure body is contained and specified in the procedure definition along with various attributes of the procedure. A package is generated for a native SQL procedure. It contains the procedure body, including control statements. It might sometimes also include statements generated by Db2. Each time that the procedure is invoked, the package executes one or more times.

All SQL procedures that are created with a CREATE PROCEDURE statement that does not specify the FENCED or EXTERNAL options are native SQL procedures. More capabilities are supported for native SQL procedures, they usually perform better than external SQL procedures, and no associated C program is generated for them.

See [“CREATE PROCEDURE statement \(SQL - native procedure\)”](#) on page 1607.

External stored procedures

The procedure body is an external program that is written in a programming language such as C, C++, COBOL, or Java and it can contain SQL statements. The source code for an external stored procedure is separate from the procedure definition and is bound into a package. The name of the external executable is specified as part of the procedure definition along with various attributes of the procedure. All programs must be designed to run using Language Environment. Your COBOL and C++ stored procedures can contain object-oriented extensions. Each time that the stored procedure is invoked, the logic in the procedure controls whether the package executes and how many times.

For more information, see [Creating external stored procedures \(Db2 Application programming and SQL\)](#).

See [“CREATE PROCEDURE statement \(external procedure\)”](#) on page 1580.

External SQL procedures (deprecated)

The procedure body is written exclusively in SQL statements, including SQL procedural language (SQL PL) statements. The procedure body is specified in the procedure definition along with various attributes of the procedure. A C program and an associated package are generated for an external SQL procedure. It contains the procedure body, including control statements. It might sometimes also include statements generated by Db2. Each time that the procedure is invoked, the package executes one or more times.

Native SQL procedures are more fully supported, easier to maintain, and typically perform better than external SQL procedures, which are deprecated.

See [“CREATE PROCEDURE statement \(SQL - external procedure\) \(deprecated\)”](#) on page 1597.

Notes for ALL procedure types

Owner privileges

The owner is authorized to call the procedure (EXECUTE privilege) and grant others the privilege to call the procedure. See [“GRANT statement \(function or procedure privileges\)”](#) on page 1970. For more information about ownership of the object, see [“Authorization, privileges, permissions, masks, and object ownership”](#) on page 90.

Defining the parameters

The input parameters for the procedure are specified as a list within parentheses.

A procedure can have no input parameters. In this case, an empty set of parentheses can be specified or omitted, for example:

```
CREATE PROCEDURE ASSEMBLY_PARTS()
```

or

```
CREATE PROCEDURE ASSEMBLY_PARTS
```

Choosing data types for parameters:

When you choose the data types of the parameters for your stored procedure, consider the rules of promotion that can affect the values of the parameters. (See [“Promotion of data types”](#) on page 129). For example, a constant that is one of the input arguments to the stored procedure might have a built-in data type that is different from the data type that the procedure expects, and more significantly, might not be promotable to that expected data type. Based on the rules of promotion, using the following data types for parameters is recommended:

- INTEGER instead of SMALLINT
- DOUBLE instead of REAL
- VARCHAR instead of CHAR
- VARGRAPHIC instead of GRAPHIC
- VARBINARY instead of BINARY

For portability of functions across platforms that are not Db2 for z/OS, do not use the following data types, which might have different representations on different platforms:

- FLOAT. Use DOUBLE or REAL instead.
- NUMERIC. Use DECIMAL instead.

Specifying the encoding scheme for parameters

The encoding scheme of all of the parameters with a character or graphic string data type (both input and output parameters) must be the same—either all ASCII, all EBCDIC, or all UNICODE. If you specify the encoding scheme on the individual parameters, instead of using the PARAMETER CCSID to specify it for all parameters at once or allowing the encoding scheme to default to the system value, ensure that they all agree.

Specifying AS LOCATOR for a parameter

Passing a locator instead of a value can result in fewer bytes being passed in or out of the procedure. This can be useful when the value of the parameter is very large. The AS LOCATOR clause specifies that a locator to the value of the parameter is passed instead of the actual value. Specify AS LOCATOR only for parameters with a LOB data type or a distinct type that is based on a LOB data type.

AS LOCATOR cannot be specified for SQL procedures.

Accessing result sets from nested stored procedures

A stored procedure, user-defined function, or trigger cannot call a stored procedure that is defined with the COMMIT ON RETURN clause.

Special registers in procedures

The settings of the special registers of the caller are inherited by the procedure when called and restored upon return to the caller. Special registers may be changed within a procedure, but these changes do not affect the caller.

Global variables in procedures

The content of global variables that are referenced in routines is inherited from the caller. Global variables can be modified in stored procedures, except when the stored procedure is called by a trigger or a function.

If the procedure contains references to global variables, the level of SQL data access must be at least CONTAINS SQL. If the procedure contains SQL statements that modify global variables, the level of SQL data access must be MODIFIES SQL DATA.

Related concepts

[Routines in Db2 for z/OS: functions and procedures \(Introduction to Db2 for z/OS\)](#)

Related tasks

[Creating stored procedures \(Db2 Application programming and SQL\)](#)

CREATE PROCEDURE statement (external procedure)

The CREATE PROCEDURE statement defines an external stored procedure at the current server.

Invocation for CREATE PROCEDURE (external)

This statement can be embedded in an application program or issued interactively. It is an executable statement that can be dynamically prepared only if DYNAMICRULES RUN behavior is in effect. For more information, see [“Authorization IDs and dynamic SQL” on page 94](#).

Authorization for CREATE PROCEDURE (external)

To create a new procedure in the implicit or explicit schema, the privilege set that is defined below must include at least one of the following:

- The CREATEIN privilege on the schema
- SYSADM or SYSCTRL authority
- System DBADM
- Installation SYSOPR authority (when the current SQLID of the process is set to SYSINSTL)

The authorization ID that matches the schema name implicitly has the CREATEIN privilege on the schema.

[FL 507](#)To replace a procedure, the privilege set that is defined below must include at least one of the following:

- Ownership of the procedure
- Both the DROPIN and CREATEIN privileges on the schema
- System DBADM authority
- SYSCTRL authority
- SYSADM authority
- Installation SYSOPR authority (when the current SQLID of the process is set to SYSINSTL)

If the authorization ID that is used to create the procedure has the installation SYSADM authority or the installation SYSOPR authority and if the current SQLID is set to SYSINSTL, the procedure is identified as system-defined procedure.

When LANGUAGE is JAVA and a *jar-name* is specified in the EXTERNAL NAME clause, the privilege set must include USAGE on the JAR file, the Java archive file.

Privilege set: If the statement is embedded in an application program, the privilege set is the privileges that are held by the owner of the plan or package. If the owner is a role, the implicit schema match does not apply and this role needs to include one of the previously listed conditions.

If the statement is dynamically prepared and is not running in a trusted context for which the ROLE AS OBJECT OWNER clause is specified, the privilege set is the set of privileges that are held by the SQL authorization ID of the process. If the schema name is not the same as the SQL authorization ID of the process, one of the following conditions must be met:

- The privilege set includes SYSADM or SYSCTRL authority.
- The SQL authorization ID of the process has the CREATEIN privilege on the schema.

The authorization ID that is used to create the stored procedure must have authority to define programs that run in the specified WLM environment. For more information, see [Managing authorizations for creation of stored procedures in WLM environments \(Managing Security\)](#).

Also, if the stored procedure uses a user-defined type as a parameter, this authorization ID must have the USAGE privilege on each parameter that is defined as a user-defined type.

Syntax for CREATE PROCEDURE (external)

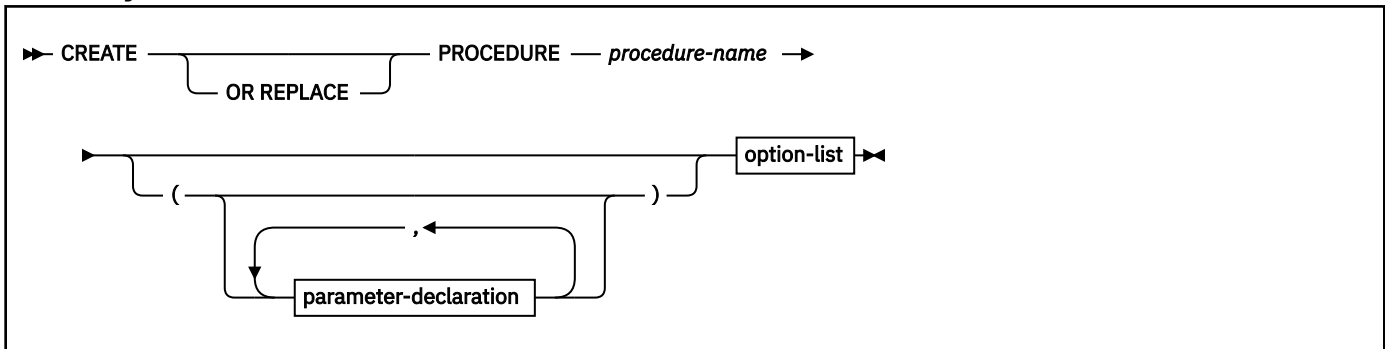

parameter-declaration:

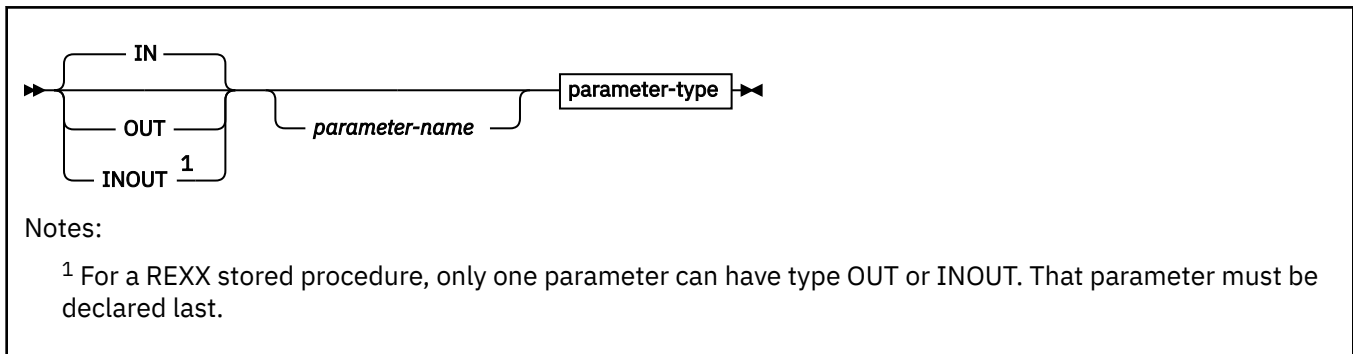

parameter-type:

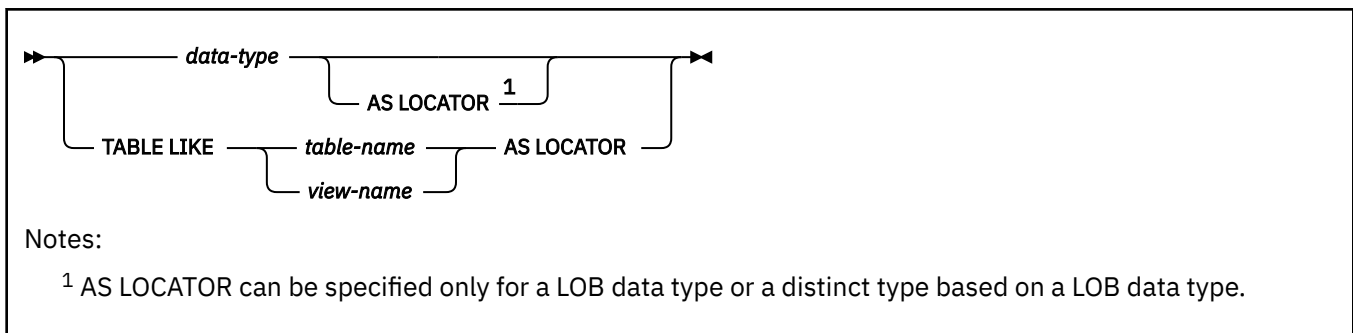

data-type:



built-in-type:

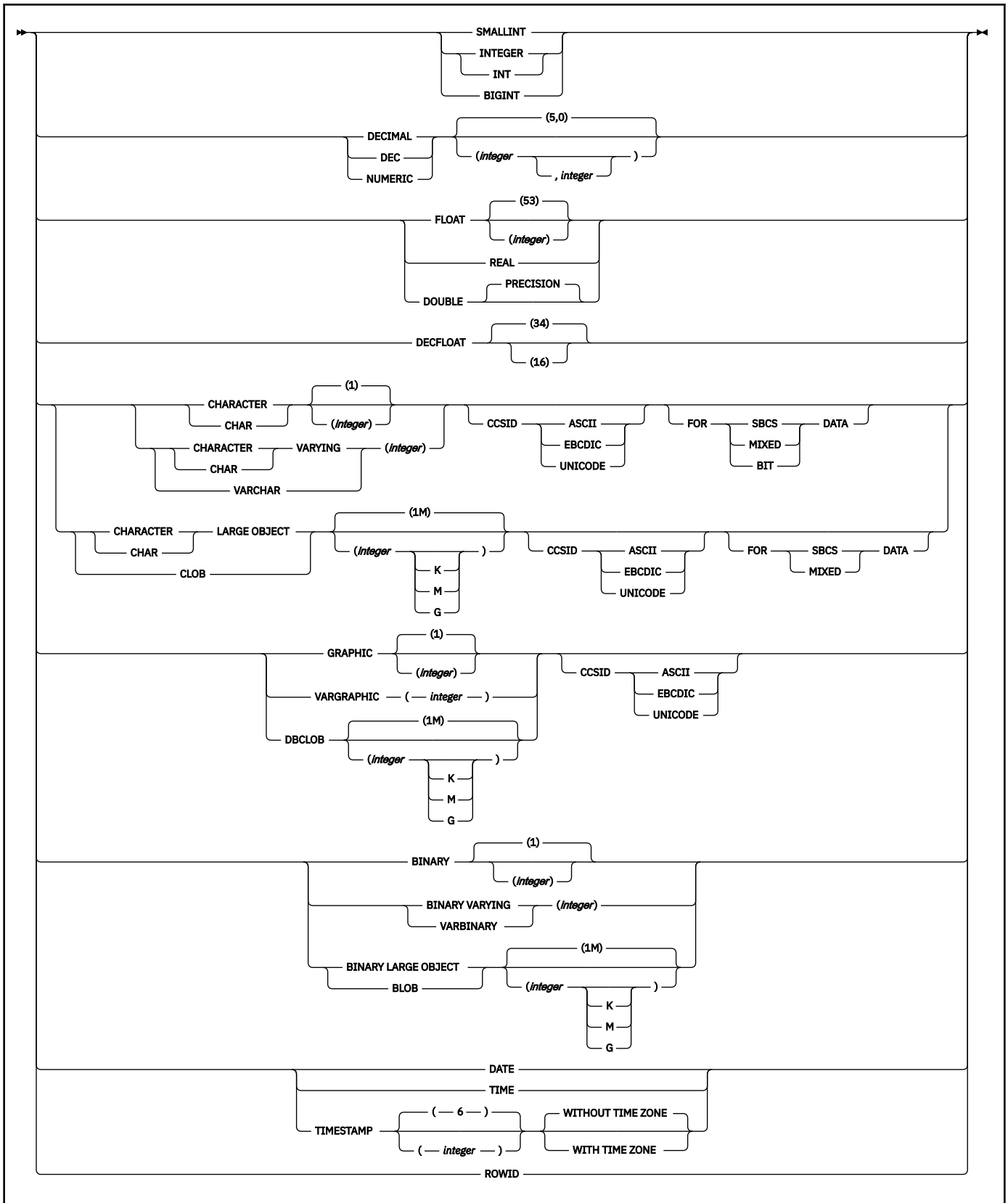

option-list: (The options can be specified in any order.)

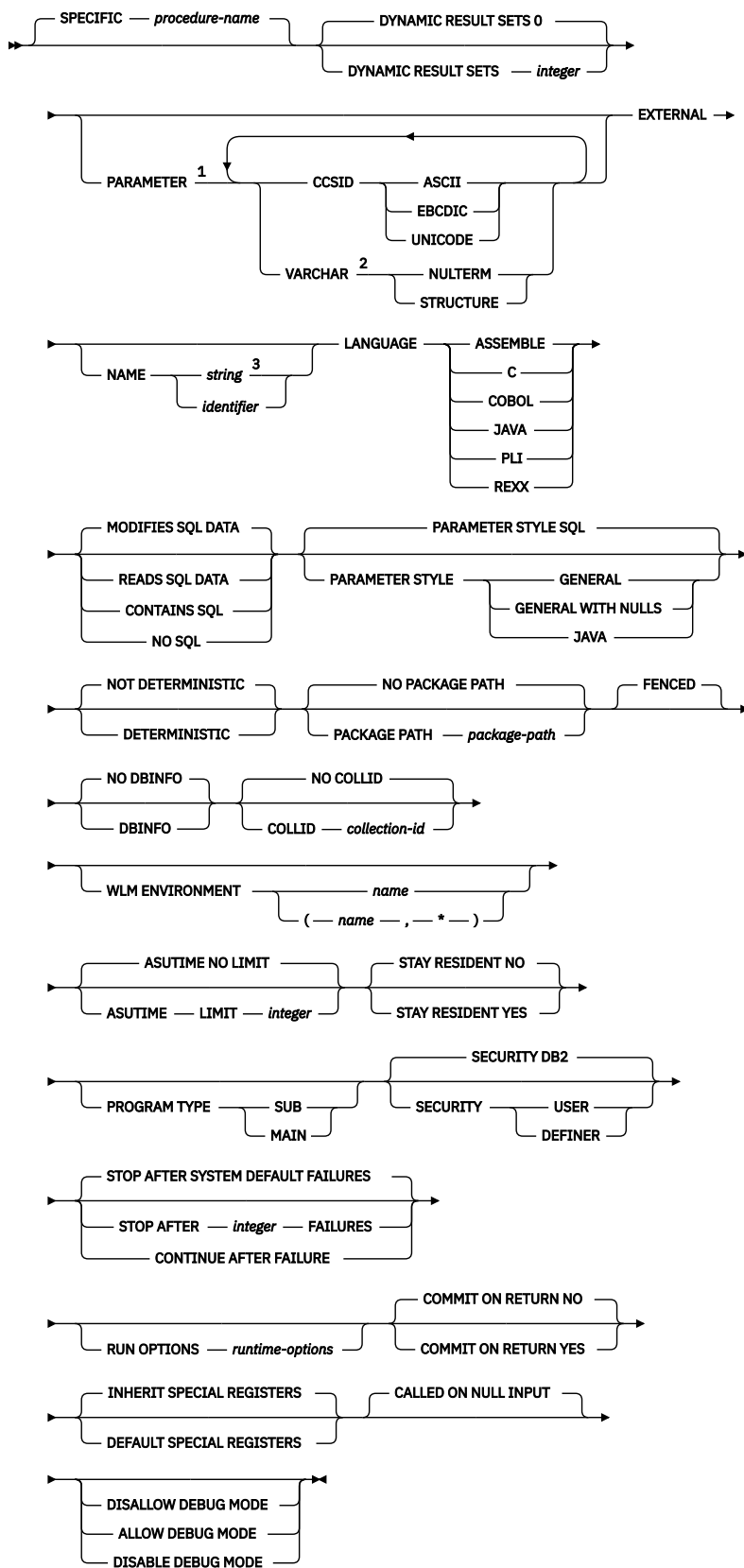

Notes:

- 1 The same clause must not be specified more than one time.
- 2 The VARCHAR clause can only be specified is LANGUAGE C is specified.

³ With LANGUAGE JAVA, use a valid *external-java-routine-name*.



external-java-routine-name

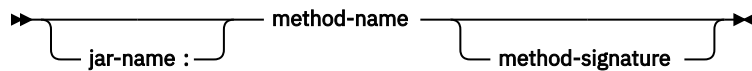

jar-name

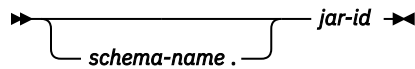

method-name

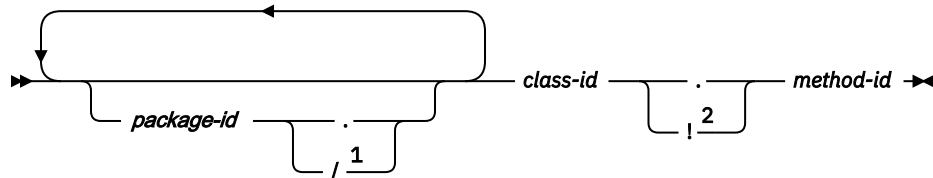

method-signature

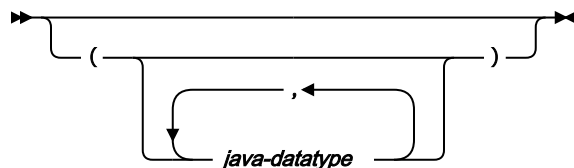

Notes:

- ¹ The slash (/) is supported for compatibility with previous releases of Db2 for z/OS.
- ² The exclamation point (!) is supported for compatibility with other products in the Db2 family.

Description for CREATE PROCEDURE (external)

OR REPLACE

FL 5075 specifies that if the procedure exists at the current server, the existing definition is replaced. This option is ignored if a definition for the procedure does not exist at the current server. If a procedure exists with the specified name, the existing procedure must be an external procedure.

If the procedure exists, the procedure is replaced. The existing definition is dropped before the new definition is replaced in the catalog, with the exception that privileges that were granted on the procedure are not affected. The procedure is recreated as follows:

- Any existing comment is discarded
- The definition of the procedure can change
- The timestamp that is associated with the procedure definition is updated
- The owner of the procedure can change
- System default values are used for options that are not explicitly specified, even if those options were explicitly specified when the procedure that is being replaced was originally defined

To replace an existing procedure, one of the following conditions must be met:

- the SPECIFIC clause must be specified with the procedure name
- the signature of the new procedure definition must match the signature of the existing procedure definition, except for parameter names

procedure-name

Names the stored procedure. The name, including the implicit or explicit qualifier, must not identify an existing stored procedure at the current server unless the OR REPLACE clause is specified.

The name cannot be a single asterisk, even if you specify it as a delimited identifier ("*").

The schema name can be 'SYSTOOLS' or 'SYSFUN' if the privilege set includes the SYSADM or SYCTRL privilege. Otherwise, the schema name must not begin with 'SYS' unless the schema name is 'SYSADM', 'SYSIBMADM', or 'SYSPROC'.

(parameter-declaration,...)

Specifies the number of parameters of the stored procedure and the data type of each parameter, and optionally, the name of each parameter. A parameter for a stored procedure can be used only for input, only for output, or for both input and output. If an error is returned by the procedure, OUT parameters are undefined and INOUT parameters are unchanged.

All parameters are nullable except for numeric parameters in Java procedures, where numeric parameters, other than the DECIMAL types are not nullable in order to conform to the SQL/JRT standard.

IN

Identifies the parameter as an input parameter to the procedure. The value of the parameter on entry to the procedure is the value that is returned to the calling SQL application, even if changes are made to the parameter within the procedure.

IN is the default.

OUT

Identifies the parameter as an output parameter that is returned by the stored procedure.

INOUT

Identifies the parameter as both an input and output parameter for the stored procedure.

parameter-name

Names the parameter for use as an SQL variable. The name cannot be the same as any other *parameter-name* for the procedure.

data-type

Specifies the data type of the parameter. The data type can be a built-in data type or a user-defined type.

If you specify the name of a user-defined type without a schema name, Db2 resolves the user-defined type by searching the schemas in the SQL path.

built-in-type

The data type of the parameter is a built-in data type.

For more information on the data types, see [built-in-type](#).

For parameters with a character or graphic data type, the PARAMETER CCSID clause or CCSID clause indicates the encoding scheme of the parameter. If you do not specify either of these clauses, the encoding scheme is the value of field DEF ENCODING SCHEME on installation panel DSNTIPF.

distinct-type-name

The data type of the input parameter is a distinct type. Any length, precision, scale, subtype, or encoding scheme attributes for the parameter are those of the source type of the distinct type.

Although an input parameter with a character data type has an implicitly or explicitly specified subtype (BIT, SBCS, or MIXED), the value that is actually passed in the input argument on the CALL statement can have any subtype. Therefore, conversion of the input data to the subtype of the parameter might occur when the procedure is called. With ASCII or EBCDIC, an error occurs if mixed data that actually contains DBCS characters is used as the value for an input parameter that is declared with an SBCS subtype.

Parameters with a datetime data type or a distinct type are passed to the function as a different data type:

- A datetime type parameter is passed as a character data type, and the data is passed in ISO format.

The encoding scheme for a datetime type parameter is the same as the implicitly or explicitly specified encoding scheme of any character or graphic string parameters. If no character or graphic string parameters are passed, the encoding scheme is the value of field DEF ENCODING SCHEME on installation panel DSNTIPF.

- A distinct type parameter is passed as the source type of the distinct type.

AS LOCATOR

Specifies that a locator to the value of the parameter is passed to the procedure instead of the actual value. Specify AS LOCATOR only for parameters with a LOB data type or a distinct type based on a LOB data type. Passing locators instead of values can result in fewer bytes being passed to the procedure, especially when the value of the parameter is very large.

The AS LOCATOR clause has no effect on determining whether data types can be promoted.

TABLE LIKE *table-name* or *view-name* AS LOCATOR

Specifies that the parameter is a transition table. However, when the procedure is called, the actual values in the transition table are not passed to the stored procedure. A single value is passed instead. This single value is a locator to the table, which the procedure uses to access the columns of the transition table. A procedure with a table parameter can only be invoked from the triggered action of a trigger.

The use of TABLE LIKE provides an implicit definition of the transition table. It specifies that the transition table has the same number of columns as the identified table or view. If a table is specified, the transition table includes columns that are defined as implicitly hidden in the table. The columns have the same data type, length, precision, scale, subtype, and encoding scheme as the identified table or view, as they are described in catalog tables SYSCOLUMNS and SYSTABLESPACES. The number of columns and the attributes of those columns are determined at the time the CREATE PROCEDURE statement is processed. Any subsequent changes to the number of columns in the table or the attributes of those columns do not affect the parameters of the procedure.

table-name or *view-name* must identify a table or view that exists at the current server. The name must not identify a declared temporary table. The table that is identified can contain XML columns; however, the procedure cannot reference those XML columns. The name does not have to be the same name as the table that is associated with the transition table for the trigger. An unqualified table or view name is implicitly qualified according to the following rules:

- If the CREATE PROCEDURE statement is embedded in a program, the implicit qualifier is the authorization ID in the QUALIFIER bind option when the plan or package was created or last rebound. If QUALIFIER was not used, the implicit qualifier is the owner of the plan or package.
- If the CREATE PROCEDURE statement is dynamically prepared, the implicit qualifier is the SQL authorization ID in the CURRENT SCHEMA special register.

When the procedure is called, the corresponding columns of the transition table identified by the table locator and the table or view identified in the TABLE LIKE clause must have the same definition. The data type, length, precision, scale, and encoding scheme of these columns must match exactly. The description of the table or view at the time the CREATE PROCEDURE statement was executed is used.

Additionally, a character FOR BIT DATA column of the transition table cannot be passed as input for a table parameter for which the corresponding column of the table specified at the definition is not defined as character FOR BIT DATA. (The definition occurs with the CREATE PROCEDURE statement.) Likewise, a character column of the transition table that is not FOR BIT DATA cannot be passed as input for a table parameter for which the corresponding column of the table specified at the definition is defined as character FOR BIT DATA.

For more information about using table locators, see [Accessing transition tables in a user-defined function or stored procedure \(Db2 Application programming and SQL\)](#).

SPECIFIC *procedure-name*

FL 507 Specifies the procedure name as the specific name for the procedure. The name must be the same as the procedure name.

If you do not specify a schema name, the schema name is the same as the explicit or implicit schema name of the procedure name (*procedure-name*). If you specify a schema name, it must be the same as the explicit or implicit schema name of the procedure name.

If you do not specify the SPECIFIC clause, the specific name is the name of the procedure.

Specify the SPECIFIC clause when replacing an existing procedure in the following situations.

- The parameter list of the existing procedure includes a table parameter
- The CREATE statement specifies changes to the parameter list other than parameter names

FENCED

Specifies that the procedure runs in an external address space.

DYNAMIC RESULT SETS *integer*

Specifies the maximum number of query result sets that the stored procedure can return. The default is DYNAMIC RESULT SETS 0, which indicates that there are no result sets. The value must be in the range 0–32767.

ALLOW DEBUG MODE, DISALLOW DEBUG MODE, or DISABLE DEBUG MODE

Specifies whether the procedure can be run in debugging mode. When DYNAMICRULES run behavior is in effect, the default is determined by using the value of the CURRENT DEBUG MODE special register. Otherwise the default is DISALLOW DEBUG MODE.

Do not specify this option unless LANGUAGE JAVA is in effect.

ALLOW DEBUG MODE

Specifies that the JAVA procedure can be run in debugging mode.

DISALLOW DEBUG MODE

Specifies that the JAVA procedure cannot be run in debugging mode.

You can use an ALTER PROCEDURE statement to change this option to ALLOW DEBUG MODE.

DISABLE DEBUG MODE

Specifies that the JAVA procedure can never be run in debugging mode.

The procedure cannot be changed to specify ALLOW DEBUG MODE or DISALLOW DEBUG MODE once the procedure has been created or altered using DISABLE DEBUG MODE. To change this option, you must drop and re-create the procedure using the option that you want.

PARAMETER CCSID or PARAMETER VARCHAR

Specifies the encoding scheme for string parameters, and in the case of LANGUAGE C, specifies the representation of variable length string parameters.

CCSID

Indicates whether the encoding scheme for character or graphic string parameters is ASCII, EBCDIC, or UNICODE. The default encoding scheme is the value specified in the CCSID clauses of the parameter list or in the field DEF ENCODING SCHEME on installation panel DSNTIPF.

This clause provides a convenient way to specify the encoding scheme for character or graphic string parameters. If individual CCSID clauses are specified for individual parameters in addition to this PARAMETER CCSID clause, the value specified in *all* of the CCSID clauses must be the same value that is specified in this clause.

This clause also specifies the encoding scheme to be used for system-generated parameters of the routine such as message tokens and DBINFO.

VARCHAR

Specifies that the representation of the values of varying length character string-parameters for procedures that specify LANGUAGE C.

This option can only be specified if LANGUAGE C is also specified.

NULTERM

Specifies that variable length character string parameters are represented in a NUL-terminated string form.

STRUCTURE

Specifies that variable length character string parameters are represented in a VARCHAR structure form.

Using the PARAMETER VARCHAR clause, there is no way to specify the VARCHAR form of an individual parameter as there is with PARAMETER CCSID. The PARAMETER VARCHAR clause only applies to parameters in the parameter list of a procedure and in the RETURNS clause. It does not apply to system-generated parameters of the routine such as message tokens and DBINFO.

In a data sharing environment, you should not specify the PARAMETER VARCHAR clause until all members of the data sharing group support the clause. If some group members support this clause and others do not, and PARAMETER VARCHAR is specified in an external routine, the routine will encounter different parameter forms depending on which group member invokes the routine.

EXTERNAL

Specifies that the CREATE PROCEDURE statement is being used to define a new procedure that is based on code written in an external programming language. If the NAME clause is not specified, 'NAME *procedure-name*' is assumed. The NAME clause is required for a LANGUAGE JAVA procedure because the default name is not valid for a Java procedure. In some cases, the default name will not be valid. To avoid invalid names, specify the NAME clause for the following types of procedures:

- A procedure that is defined as LANGUAGE JAVA
- A procedure that has a name that is greater than 8 bytes in length, contains an underscore, or does not conform to the rules for an ordinary identifier.

NAME *string* or *identifier*

Identifies the user-written code that implements the stored procedure.

If LANGUAGE is JAVA, *string* must be specified and enclosed in single quotation marks, with no extraneous blanks within the single quotation marks. It must specify a valid *external-java-routine-name*. If multiple *strings* are specified, the total length of all of them must not be greater than 1305 bytes and they must be separated by a space or a line break.

An *external-java-routine-name* contains the following parts:

jar-name

Identifies the name given to the JAR file when it was installed in the database. The name contains *jar-id*, which can optionally be qualified with a schema. Examples are "myJar" and "mySchema.myJar." The unqualified *jar-id* is implicitly qualified with a schema name according to the following rules:

- If the statement is embedded in a program, the schema name is the authorization ID in the QUALIFIER bind option when the package or plan was created or last rebound. If the QUALIFIER was not specified, the schema name is the owner of the package or plan.
- If the statement is dynamically prepared, the schema name is the SQL authorization ID in the CURRENT SCHEMA special register.

If *jar-name* is specified, it must exist when the CREATE PROCEDURE statement is processed. Do not specify a *jar-name* for a JAVA procedure for which NO SQL is also specified.

If *jar-name* is not specified, the procedure is loaded from the class file directly instead of being loaded from a JAR file. Db2 searches the directories in the CLASSPATH associated with the WLM Environment. Environmental variables for Java routines are specified in a data set identified in a JAVAENV DD card on the JCL used to start the address space for a WLM-managed stored procedure.

method-name

Identifies the name of the method and must not be longer than 254 bytes. Its package, class, and method ID's are specific to Java and as such are not limited to 18 bytes. In addition, the rules for what these can contain are not necessarily the same as the rules for an SQL ordinary identifier.

package-id

Identifies a package. The concatenated list of *package-ids* identifies the package that the class identifier is part of. If the class is part of a package, the method name must include the complete package prefix, such as "myPacks.StoredProcs." The Java virtual machine looks in the directory "/myPacks/StoredProcs/" for the classes.

class-id

Identifies the class identifier of the Java object.

method-id

Identifies the method identifier with the Java class to be invoked.

method-signature

Identifies a list of zero or more Java data types for the parameter list and must not be longer than 1024 bytes. Specify the *method-signature* if the procedure involves any input or output parameters that can be NULL. When the stored procedure being created is called, Db2 searches for a Java method with the exact *method-signature*. The number of *java-datatype* elements specified indicates how many parameters that the Java method must have.

A Java procedure can have no parameters. In this case, you code an empty set of parentheses for *method-signature*. If a Java *method-signature* is not specified, Db2 searches for a Java method with a signature derived from the default JDBC types associated with the SQL types specified in the parameter list of the CREATE PROCEDURE statement.

For other values of LANGUAGE, the value must conform to the naming conventions for MVS load modules: the value must be less than or equal to 8 bytes, and it must conform to the rules for an ordinary identifier with the exception that it must not contain an underscore.

LANGUAGE

This mandatory clause is used to specify the language interface convention to which the procedure body is written. All programs must be designed to run in the server's environment. Assembler, C, COBOL, and PL/I programs must be designed to run in IBM's Language Environment.

ASSEMBLE

The stored procedure is written in Assembler.

C

The stored procedure is written in C or C++.

COBOL

The stored procedure is written in COBOL, including the OO-COBOL language extensions.

JAVA

The stored procedure is written in Java and is executed in the Java Virtual Machine. When LANGUAGE JAVA is specified, the EXTERNAL NAME clause must be specified with a valid *external-java-routine-name* and PARAMETER STYLE must be specified with JAVA. The procedure must be a public static method of the specified Java class.

Do not specify LANGUAGE JAVA when DBINFO, PROGRAM TYPE MAIN, or RUN OPTIONS is specified.

PLI

The stored procedure is written in PL/I.

REXX

The stored procedure is written in REXX. Do not specify LANGUAGE REXX when PARAMETER STYLE SQL is in effect. When REXX is specified, the procedure must use PARAMETER STYLE GENERAL or GENERAL WITH NULLS.

MODIFIES SQL DATA, READS SQL DATA, CONTAINS SQL, or NO SQL

Specifies the classification of SQL statements and nested routines that this routine can execute or invoke. The database manager verifies that the SQL statements issued by the procedure, and all routines locally invoked by the routine, are consistent with this specification; the verification is not performed when nested remote routines are invoked. For the classification of each statement, see [Appendix D, “SQL statement data access classification for routines,”](#) on page 2275.

MODIFIES SQL DATA

Specifies that the procedure can execute any SQL statement except statements that are not supported in procedures.

READS SQL DATA

Specifies that the procedure can execute statements with a data access indication of READS SQL DATA, CONTAINS SQL, or NO SQL. The procedure cannot execute SQL statements that modify data.

CONTAINS SQL

Specifies that the procedure can execute only SQL statements with an access indication of CONTAINS SQL or NO SQL. The procedure cannot execute statements that read or modify data.

NO SQL

Specifies that the procedure can execute only SQL statements with a data access classification of NO SQL. Do not specify NO SQL for a JAVA procedure that uses a JAR file.

PARAMETER STYLE

Identifies the linkage convention used to pass parameters to and return values from the stored procedure. All of the linkage conventions provide arguments to the stored procedure that contain the parameters specified on the CALL statement. Some of the linkage conventions pass additional arguments to the stored procedure that provide more information to the stored procedure. For more information on linkage conventions, see [Linkage conventions for external stored procedures \(Db2 Application programming and SQL\)](#).

SQL

Specifies that, in addition to the parameters on the CALL statement, several additional parameters are passed to the stored procedure. The following parameters are passed:

- The first n parameters that are specified on the CREATE PROCEDURE statement.
- n parameters for indicator variables for the parameters.
- The SQLSTATE to be returned.
- The qualified name of the stored procedure.
- The specific name of the stored procedure.
- The SQL diagnostic string to be returned to Db2.
- If DBINFO is specified, the DBINFO structure.

PARAMETER STYLE SQL is the default. Do not specify PARAMETER STYLE SQL when LANGUAGE REXX or LANGUAGE JAVA is in effect.

GENERAL

Specifies that the stored procedure uses a parameter passing mechanism where the stored procedure receives only the parameters specified on the CALL statement. Arguments to procedures defined with this parameter style cannot be null.

GENERAL WITH NULLS

Specifies that, in addition to the parameters on the CALL statement as specified in GENERAL, another argument is also passed to the stored procedure. The additional argument contains an indicator array with an element for each of the parameters on the CALL statement. In C, this is an array of short INTS. The indicator array enables the stored procedure to accept or return null parameter values.

JAVA

Specifies that the stored procedure uses a parameter passing convention that conforms to the Java and SQLJ Routines specifications. PARAMETER JAVA can be specified only if LANGUAGE is JAVA. JAVA must be specified for PARAMETER STYLE when LANGUAGE is JAVA.

INOUT and OUT parameters are passed as single-entry arrays. The INOUT and OUT parameters are declared in the Java method as single-element arrays of the Java type.

For REXX stored procedures (LANGUAGE REXX), GENERAL and GENERAL WITH NULLS are the only valid values for PARAMETER STYLE; therefore, specify one of these values and do not allow PARAMETER STYLE to default to SQL.

DETERMINISTIC or NOT DETERMINISTIC

Specifies whether the stored procedure returns the same results each time the stored procedure is called with the same IN and INOUT arguments.

DETERMINISTIC

The stored procedure always returns the same results each time the stored procedure is called with the same IN and INOUT arguments, if the referenced data in the database has not changed.

NOT DETERMINISTIC

The stored procedure might not return the same result each time the procedure is called with the same IN and INOUT arguments, even when the referenced data in the database has not changed. NOT DETERMINISTIC is the default.

Db2 does not verify that the stored procedure code is consistent with the specification of DETERMINISTIC or NOT DETERMINISTIC.

NO PACKAGE PATH or PACKAGE PATH *package-path*

Specifies the package path to use when the procedure is run. This is the list of the possible package collections into which the DBRM this is associated with the procedure is bound.

NO PACKAGE PATH

Specifies that the list of package collections for the procedure is the same as the list of package collection IDs for the calling program. If the calling program does not use a package, Db2 resolves the package by using the CURRENT PACKAGE PATH special register, the CURRENT PACKAGESET special register, or the PKLIST bind option (in this order). For information about how Db2 uses these three items, see [Binding an application plan \(Db2 Application programming and SQL\)](#).

PACKAGE PATH *package-path*

Specifies a list of package collections, in the same format as the SET CURRENT PACKAGE PATH special register.

If the COLLID clause is specified with PACKAGE PATH, the COLLID clause is ignored when the routine is invoked.

The *package-path* value that is provided when the procedure is created is checked when the CALL statement is prepared. If *package-path* contains SESSION_USER (or USER), PATH, or PACKAGE PATH, an error is returned when the *package-path* value is checked.

NO DBINFO or DBINFO

Specifies whether additional status information is passed to the stored procedure when it is invoked.

NO DBINFO

Additional information is not passed. NO DBINFO is the default.

DBINFO

An additional argument is passed when the stored procedure is invoked. The argument is a structure that contains information such as the name of the current server, the application run time authorization ID and identification of the version and release of the database manager that invoked the procedure. For details about the argument and its structure, see [DBINFO structure \(Db2 Application programming and SQL\)](#).

DBINFO can be specified only if PARAMETER STYLE SQL is specified.

NO COLLID or COLLID *collection-id*

Identifies the package collection that is to be used when the stored procedure is executed. This is the package collection into which the DBRM that is associated with the stored procedure is bound.

NO COLLID

The package collection for the stored procedure is the same as the package collection of the calling program. If the invoking program does not use a package, Db2 resolves the package by using the CURRENT PACKAGE PATH special register, the CURRENT PACKAGESET special register, or the PKLIST bind option (in this order). For details about how Db2 uses these three items, see the information on package resolution in [Binding an application plan \(Db2 Application programming and SQL\)](#).

NO COLLID is the default.

COLLID *collection-id*

The package collection for the stored procedure is the one specified.

For REXX stored procedures, *collection-id* can be DSNREXRR, DSNREXRS, DSNREXCR, or DSNREXCS.

For Java stored procedures that meet these conditions, you need to run the DB2Binder utility with the -collection option to bind the driver packages into the collection that is specified by the COLLID value:

- The COLLID value is different from the collection into which the IBM Data Server Driver for JDBC and SQLJ packages are bound.
- *jar-name* is specified in the EXTERNAL NAME clause.

For more information, see the following topics:

- [Specifying the package collection that Db2 uses for applications \(Db2 Application programming and SQL\)](#)
- [DB2Binder utility \(Db2 Application Programming for Java\)](#)

WLM ENVIRONMENT

Identifies the WLM (workload manager) environment in which the stored procedure is to run when the Db2 stored procedure address space is WLM-established. The *name* of the WLM environment is an SQL identifier.

If you do not specify WLM ENVIRONMENT, the stored procedure runs in the default WLM-established stored procedure address space specified at installation time.

name

The WLM environment in which the stored procedure must run. If another stored procedure or a user-defined function calls the stored procedure and that calling routine is running in an address space that is not associated with the specified WLM environment, Db2 routes the stored procedure request to a different address space.

(name,*)

When an SQL application program directly calls a stored procedure, the WLM environment in which the stored procedure runs.

If another stored procedure or a user-defined function calls the stored procedure, the stored procedure runs in the same WLM environment that the calling routine uses.

You must have appropriate authority for the WLM environment.

ASUTIME

Specifies the total amount of processor time, in CPU service units, that a single invocation of a stored procedure can run. The value is unrelated to the ASUTIME column of the resource limit specification table. This option is ignored if LANGUAGE JAVA is specified.

When you are debugging a stored procedure, setting a limit can be helpful in case the stored procedure gets caught in a loop. For information on service units, see [z/OS MVS Initialization and Tuning Guide](#).

NO LIMIT

There is no limit on the service units. NO LIMIT is the default.

LIMIT *integer*

The limit on the number of CPU service units is a positive *integer* in the range 1–2147483647. If the procedure uses more service units than the specified value, Db2 cancels the procedure. The CPU cycles that are consumed by parallel tasks in a procedure do not contribute towards the specified ASUTIME LIMIT.

STAY RESIDENT

Specifies whether the stored procedure load module is to remain resident in memory when the stored procedure ends. This option is ignored if LANGUAGE JAVA is specified.

NO

The load module is deleted from memory after the stored procedure ends. NO is the default.

YES

The load module remains resident in memory after the stored procedure ends.

PROGRAM TYPE

Specifies whether the stored procedure runs as a main routine or a subroutine.

SUB

The stored procedure runs as a subroutine. With LANGUAGE JAVA, PROGRAM TYPE SUB is the only valid option.

MAIN

The stored procedure runs as a main routine. With LANGUAGE REXX, PROGRAM TYPE MAIN is always in effect.

The default for PROGRAM TYPE is:

- MAIN with LANGUAGE REXX
- SUB with LANGUAGE JAVA
- For other languages, the default depends on the value of the CURRENT RULES special register:
 - MAIN when the value is Db2
 - SUB when the value is STD

SECURITY

Specifies how the stored procedure interacts with an external security product, such as RACF, to control access to non-SQL resources.

Db2

The stored procedure does not require a special external security environment. If the stored procedure accesses resources that an external security product protects, the access is performed using the authorization ID associated with the stored procedure address space. Db2 is the default.

USER

An external security environment should be established for the stored procedure. If the stored procedure accesses resources that the external security product protects, the access is performed using the authorization ID of the user who invoked the stored procedure.

DEFINER

An external security environment should be established for the stored procedure. If the stored procedure accesses resources that the external security product protects, the access is performed using the authorization ID of the owner of the stored procedure.

STOP AFTER SYSTEM DEFAULT FAILURES, STOP AFTER *nn* FAILURES, or CONTINUE AFTER FAILURE

Specifies whether the routine is to be put in a stopped state after some number of failures.

STOP AFTER SYSTEM DEFAULT FAILURES

Specifies that this routine should be placed in a stopped state after the number of failures indicated by the value of field MAX ABEND COUNT on installation panel DSNTIPX. This is the default.

STOP AFTER *nn* FAILURES

Specifies that this routine should be placed in a stopped state after *nn* failures. The value *nn* can be an integer 1–32767.

CONTINUE AFTER FAILURE

Specifies that this routine should not be placed in a stopped state after any failure.

RUN OPTIONS *runtime-options*

Specifies the Language Environment run time options to be used for the stored procedure. For a REXX stored procedure, specifies the Language Environment run time options to be passed to the REXX language interface to Db2. You must specify *runtime-options* as a character string that is no longer than 254 bytes. If you do not specify RUN OPTIONS or pass an empty string, Db2 does not pass any run time options to Language Environment, and Language Environment uses its installation defaults.

Do not specify RUN OPTIONS when LANGUAGE JAVA is in effect.

For a description of the Language Environment run time options, see [Language Environment Programming Reference \(z/OS Language Environment Programming Reference\)](#).

COMMIT ON RETURN

Indicates whether Db2 commits the transaction immediately on return from the stored procedure.

NO

Db2 does not issue a commit when the stored procedure returns. NO is the default.

YES

Db2 issues a commit when the stored procedure returns if the following statements are true:

- The SQLCODE that is returned by the CALL statement is not negative.
- The stored procedure is not in a must abort state.

The commit operation includes the work that is performed by the calling application process and the stored procedure.

If the stored procedure returns result sets, the cursors that are associated with the result sets must have been defined as WITH HOLD to be usable after the commit.

INHERIT SPECIAL REGISTERS or DEFAULT SPECIAL REGISTERS

Specifies how special registers are set on entry to the routine. The default is INHERIT SPECIAL REGISTERS.

INHERIT SPECIAL REGISTERS

Specifies that the values of special registers are inherited according to the rules listed in the table for characteristics of special registers in a stored procedure in [“Special registers in a user-defined function or a stored procedure” on page 215](#).

DEFAULT SPECIAL REGISTERS

Specifies that special registers are initialized to the default values, as indicated by the rules in the table for characteristics of special registers in a stored procedure in [“Special registers in a user-defined function or a stored procedure” on page 215](#).

CALLED ON NULL INPUT

Specifies that the procedure is to be called even if any or all argument values are null, which means that the procedure must be coded to test for null argument values. The procedure can return null or nonnull values. CALLED ON NULL INPUT is the default.

Notes for CREATE PROCEDURE (external)**Considerations for all types of procedures**

For considerations that apply to all types of procedures, see [“CREATE PROCEDURE statement \(overview\)” on page 1578](#).

Character string representation considerations

The PARAMETER VARCHAR clause is specific to external procedures because of the native use of NUL-terminated strings in C. VARCHAR structure representation is useful when character string data

is known to contain embedded NUL-terminators. It is also useful when it cannot be guaranteed that character string data does not contain embedded NUL-terminators.

PARAMETER VARCHAR does not apply to fixed length character strings, VARCHAR FOR BIT DATA, CLOB, DBCLOB, or implicitly generated parameters. The clause does not apply to VARCHAR FOR BIT DATA because BIT DATA can contain X'00' characters, and its value representation starts with length information. It does not apply to LOB data because a LOB value representation starts with length information.

PARAMETER VARCHAR does not apply to optional parameters that are implicitly provided to an external procedure. For example, a CREATE PROCEDURE statement for LANGUAGE C must also specify PARAMETER STYLE SQL, which returns an SQLSTATE NUL-terminated character string; that SQLSTATE will not be represented in VARCHAR structured form. Likewise, none of the parameters that represent the qualified name of the procedure, the specific name of the procedure, or the SQL diagnostic string that is returned to the database manager will be represented in VARCHAR structured form.

Environment for running stored procedures

You can use the WLM ENVIRONMENT clause to identify the address space in which a stored procedure is to run. Using different WLM environments lets you isolate one group of programs from another. For example, you might choose to isolate programs based on security requirements and place all payroll applications in one WLM environment because those applications deal with sensitive data, such as employee salaries.

Regardless of where the stored procedure is to run, Db2 invokes RACF to determine whether you have appropriate authorization. You must have authorization to issue CREATE PROCEDURE statements that refer to the specified WLM environment or the Db2-established stored procedure address space. For example, the following RACF command authorizes Db2 user DB2USER1 to define stored procedures on Db2 subsystem DB2A that run in the WLM environment named PAYROLL.

```
PERMIT DB2A.WLMENV.PAYROLL CLASS(DSNR) ID(DB2USER1) ACCESS(READ)
```

Alternative syntax and synonyms

To provide compatibility with previous releases of Db2 or other products in the Db2 family, Db2 supports the following alternative syntax:

- RESULT SET as a synonym for DYNAMIC RESULT SET
- RESULT SETS as a synonym for DYNAMIC RESULT SETS
- STANDARD CALL as a synonym for DB2SQL
- SIMPLE CALL as a synonym for GENERAL
- SIMPLE CALL WITH NULLS as a synonym for GENERAL WITH NULLS
- VARIANT as a synonym for NOT DETERMINISTIC
- NOT VARIANT as a synonym for DETERMINISTIC
- NULL CALL as a synonym for CALLED ON NULL INPUT
- PARAMETER STYLE DB2SQL as a synonym for PARAMETER STYLE SQL

Examples for CREATE PROCEDURE (external)

Example 1

Create the definition for a stored procedure that is written in COBOL. The procedure accepts an assembly part number and returns the number of parts that make up the assembly, the total part cost, and a result set. The result set lists the part numbers, quantity, and unit cost of each part. Assume that the input parameter cannot contain a null value and that the procedure is to run in a WLM environment called PARTSA.

```
CREATE PROCEDURE SYSPROC.MYPROC(IN INT, OUT INT, OUT DECIMAL(7,2))  
LANGUAGE COBOL  
EXTERNAL NAME MYMODULE
```



```
PARAMETER STYLE GENERAL
WLM ENVIRONMENT PARTSA
DYNAMIC RESULT SETS 1;
```

Example 2

Create the definition for the stored procedure described in Example 1, except use the linkage convention that passes more information than the parameter specified on the CALL statement. Specify Language Environment run time options HEAP, BELOW, ALL31, and STACK.

```
CREATE PROCEDURE SYSPROC.MYPROC(IN INT, OUT INT, OUT DECIMAL(7,2))
LANGUAGE COBOL
EXTERNAL NAME MYMODULE
PARAMETER STYLE SQL
WLM ENVIRONMENT PARTSA
DYNAMIC RESULT SETS 1
RUN OPTIONS 'HEAP(, ,ANY),BELOW(4K, ,),ALL31(ON),STACK(, ,ANY,)' ;
```

Example 3

Create the procedure definition for a stored procedure, written in Java, that is passed a part number and returns the cost of the part and the quantity that is currently available.

```
CREATE PROCEDURE PARTS_ON_HAND(IN PARTNUM INT,
                                OUT COST DECIMAL(7,2),
                                OUT QUANTITY INT)
LANGUAGE JAVA
EXTERNAL NAME 'PARTS.ONHAND'
PARAMETER STYLE JAVA;
```

Related concepts

[Routines in Db2 for z/OS: functions and procedures \(Introduction to Db2 for z/OS\)](#)

[Naming conventions](#)

The rules for forming a name depend on the type of the object designated by the name.

Related tasks

[Implementing Db2 stored procedures \(Stored procedures provided by Db2\)](#)

CREATE PROCEDURE statement (SQL - external procedure) (deprecated)

The CREATE PROCEDURE statement defines an external SQL procedure at the current server and specifies the source statements for the procedure. This is the only type of SQL procedure that is available for versions of Db2 prior to DB2 9.

Deprecated function: External SQL procedures are deprecated and not as fully supported as native SQL procedures. For best results, create native SQL procedures instead. For more information, see [Creating native SQL procedures \(Db2 Application programming and SQL\)](#) and [Migrating an external SQL procedure to a native SQL procedure \(Db2 Application programming and SQL\)](#).

For information about the SQL control statements that are supported in external SQL procedures, refer to [Appendix E, "SQL control statements for external SQL procedures,"](#) on page 2279.

Invocation for CREATE PROCEDURE (SQL - external)

This statement can only be dynamically prepared, but the DYNAMICRULES run behavior must be specified implicitly or explicitly. It is intended to be processed using one of the following methods:

- JCL
- The Db2 for z/OS SQL procedure processor (DSNTPSMP) (IBM Optim™ Development Studio uses this method.)

Issuing the CREATE PROCEDURE statement from another context will result in an incomplete procedure definition even though the statement processing returns without error. For more information on preparing SQL procedures for execution, see [Creating external SQL procedures \(deprecated\) \(Db2 Application programming and SQL\)](#).

Authorization for CREATE PROCEDURE (SQL - external)

The privilege set that is defined below must include at least one of the following:

- The CREATEIN privilege on the schema
- SYSADM or SYSCTRL authority
- System DBADM
- Installation SYSOPR authority (when the current SQLID of the process is set to SYSINSTL)

The authorization ID that matches the schema name implicitly has the CREATEIN privilege on the schema.

If the authorization ID that is used to create the procedure has the installation SYSADM authority or the installation SYSOPR authority and if the current SQLID is set to SYSINSTL, the procedure is identified as system-defined procedure.

Privilege set: If the statement is embedded in an application program, the privilege set is the privileges that are held by the owner of the plan or package. If the owner is a role, the implicit schema match does not apply and this role needs to include one of the previously listed conditions.

If the statement is dynamically prepared and is not running in a trusted context for which the ROLE AS OBJECT OWNER clause is specified, the privilege set is the set of privileges that are held by the SQL authorization ID of the process. If the schema name is not the same as the SQL authorization ID of the process, one of the following conditions must be met:

- The privilege set includes SYSADM or SYSCTRL authority.
- The SQL authorization ID of the process has the CREATEIN privilege on the schema.

The authorization ID that is used to create the stored procedure must have authority to create programs that are to be run in the specified WLM environment.

The owner of the procedure is determined by how the CREATE PROCEDURE statement is invoked:

- If the statement is embedded in a program, the owner is the authorization ID of the owner of the plan or package.
- If the statement is dynamically prepared, the owner is the SQL authorization ID in the CURRENT SQLID special register.

The owner is implicitly given the EXECUTE privilege with the GRANT option for the procedure.

Syntax for CREATE PROCEDURE (SQL - external)

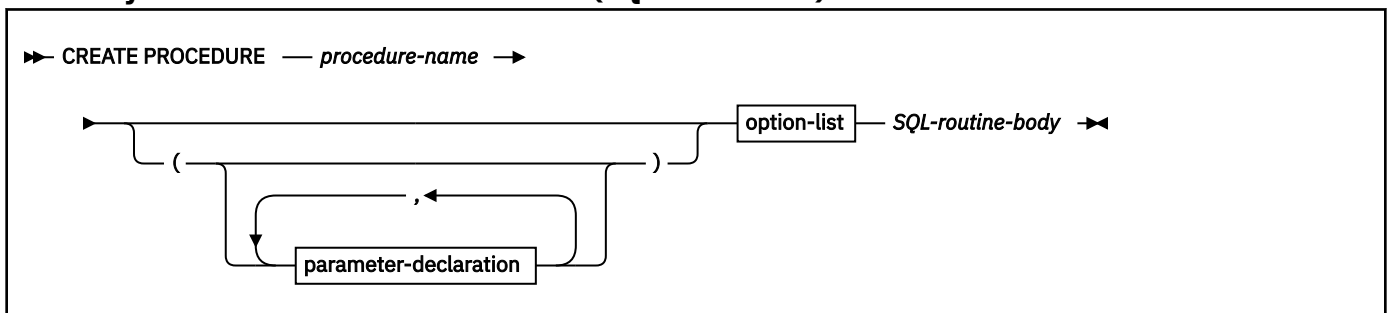

parameter-declaration:

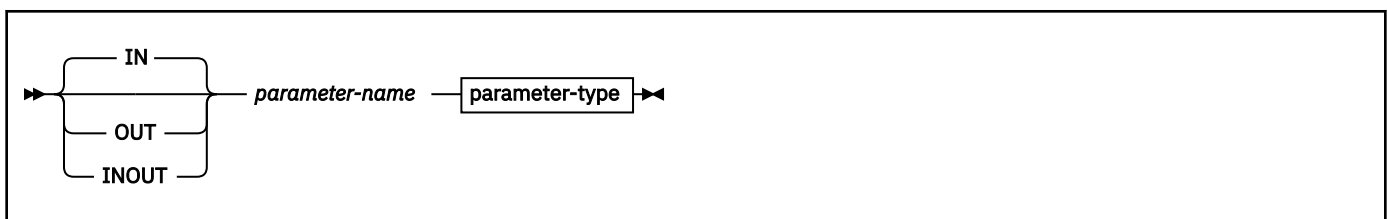

parameter-type:



built-in-type:

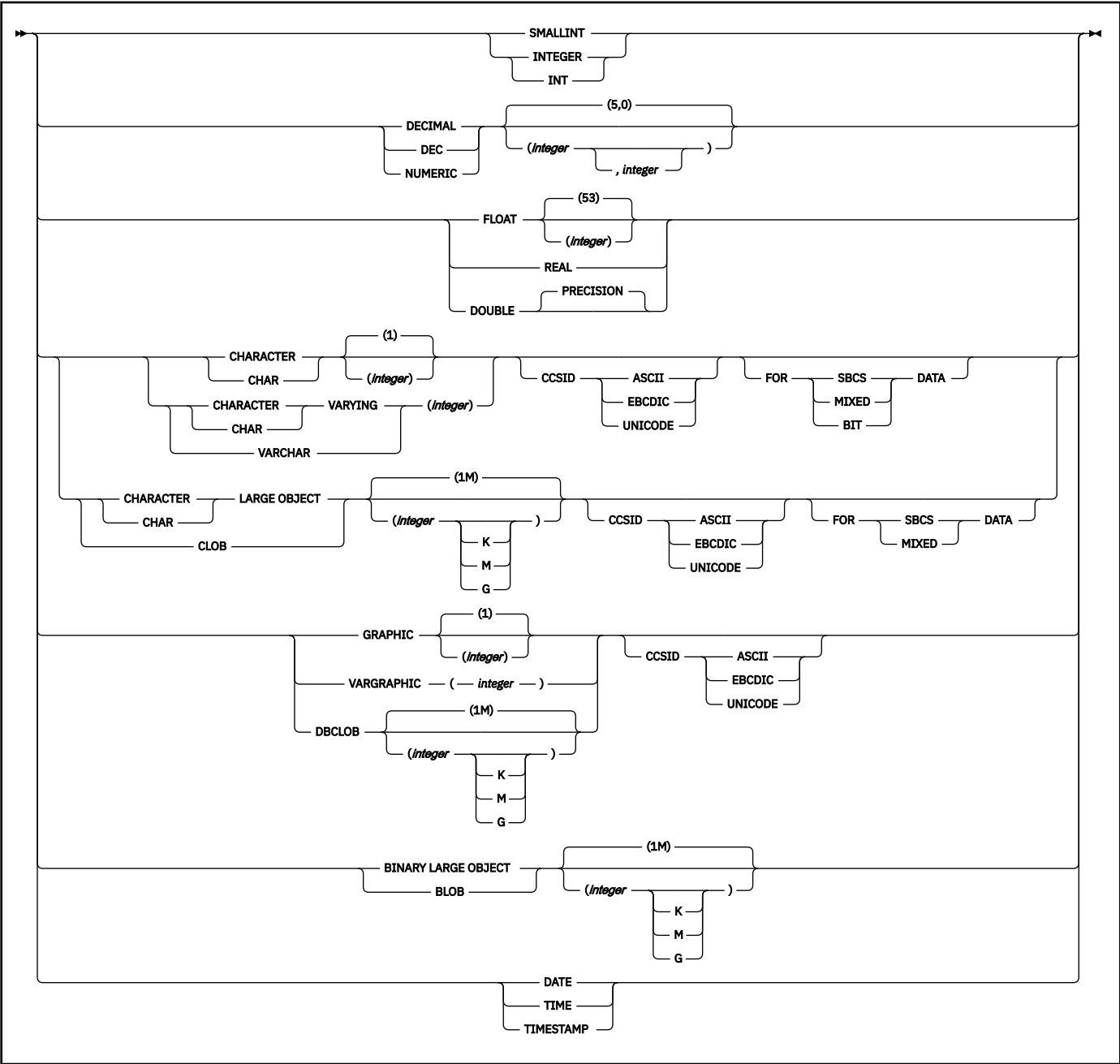

option-list: (The options can be specified in any order, but each option can be specified only one time)

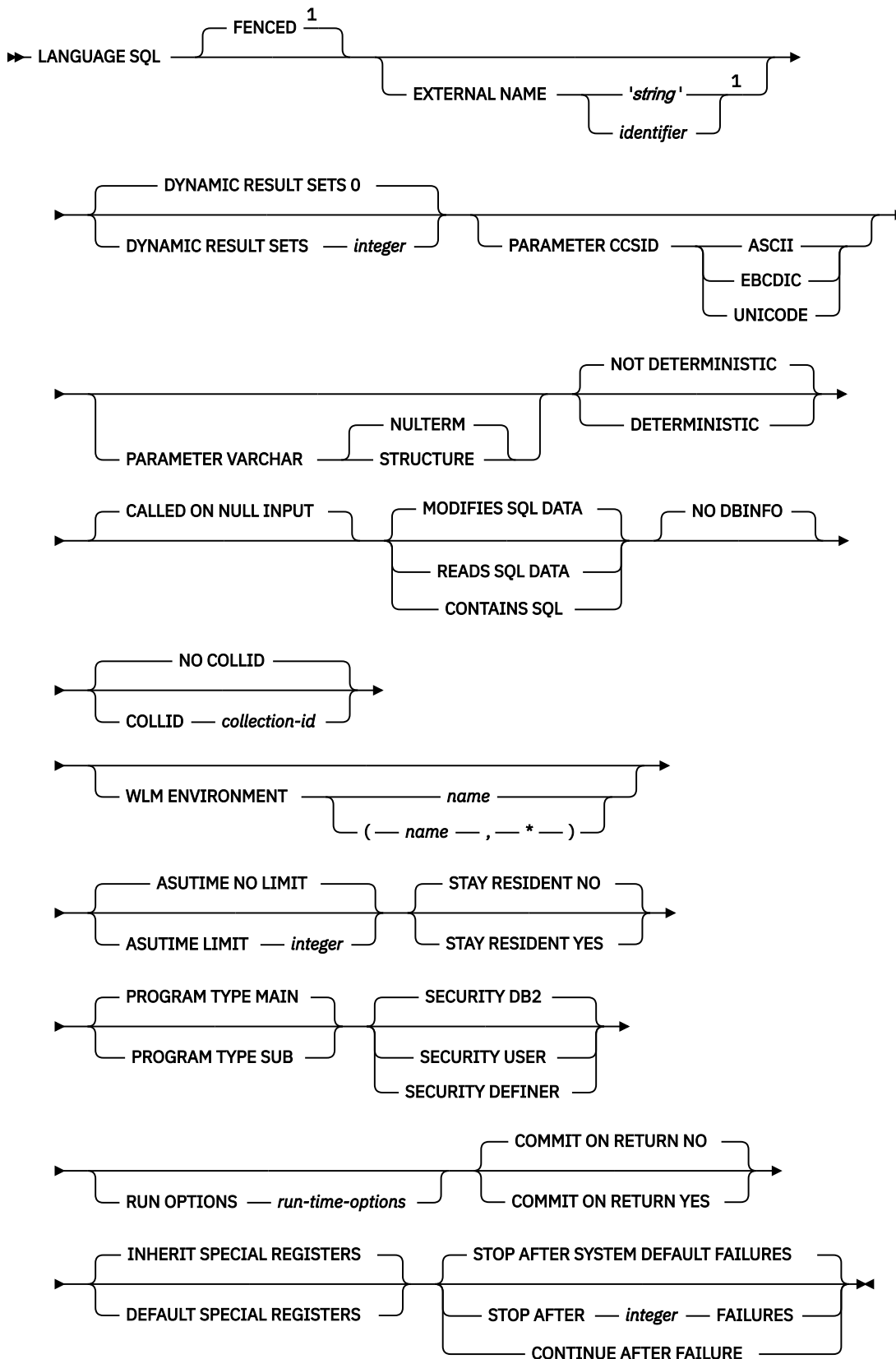

Notes:

¹ Either the FENCED or EXTERNAL NAME clause must be specified to indicate that the definition is for an external SQL procedure.

Description for CREATE PROCEDURE (SQL - external)

procedure-name

Names the procedure. The name, including the implicit or explicit qualifier, must not identify an existing stored procedure at the current server.

The schema name can be 'SYSTOOLS' or 'SYSFUN' if the privilege set includes the SYSADM or SYSCTRL privilege. Otherwise, the schema name must not begin with 'SYS' unless the schema name is 'SYSADM', 'SYSIBMADM', or 'SYSPROC'.

(parameter-declaration,...)

Specifies the number of parameters of the procedure, the data type of each parameter, and the name of each parameter. A parameter for a procedure can be used only for input, only for output, or for both input and output. If an error is returned by the procedure, OUT parameters are undefined, and INOUT parameters are unchanged. All of the parameters are nullable.

IN

Identifies the parameter as an input parameter to the procedure. The value of the parameter on entry to the procedure is the value that is returned to the calling SQL application, even if changes are made to the parameter within the procedure.

IN is the default.

OUT

Identifies the parameter as an output parameter that is returned by the procedure. If the parameter is not set within the procedure, the null value is returned.

INOUT

Identifies the parameter as both an input and output parameter for the procedure. If the parameter is not set within the procedure, its input value is returned.

parameter-name

Names the parameter for use as an SQL variable. *parameter-name* is an SQL identifier and must not be a delimited identifier that includes lowercase letters or special characters. A parameter name cannot be the same as the name of any other parameter for this version of the procedure.

parameter-type

Specifies the data type of the parameter.

built-in-type

The data type of the parameter is a built-in data type.

For more information on the data types, including the subtype of character data types (the FOR *subtype* DATA clause), see [built-in-type](#). For external SQL procedures, the maximum limit for VARCHAR is 32767 and for VARGRAPHIC is 16382.

For parameters with a character or graphic data type, the PARAMETER CCSID clause or CCSID clause indicates the encoding scheme of the parameter. If you do not specify either of these clauses, the encoding scheme is the value of field DEF ENCODING SCHEME on installation panel DSNTIPF.

Although an input parameter with a character data type has an implicitly or explicitly specified subtype (BIT, SBCS, or MIXED), the value that is actually passed in the input parameter can have any subtype. Therefore, conversion of the input data to the subtype of the parameter might occur when the procedure is called. With ASCII or EBCDIC, an error occurs if mixed data that actually contains DBCS characters is used as the value for an input parameter that is declared with an SBCS subtype.

A parameter with a datetime data type is passed to the SQL procedure as a character data type, and the data is passed in ISO format.

The encoding scheme for a datetime type parameter is determined as follows:

- If there are one or more parameters with a character or graphic data type, the encoding scheme of the datetime type parameter is the same as the encoding scheme of the character or graphic parameters.

- Otherwise, the encoding scheme is the value of field DEF ENCODING SCHEME on installation panel DSNTIPF.

TABLE LIKE *table-name* AS LOCATOR

Specifies that the parameter is a transition table. However, when the procedure is called, the actual values in the transition table are not passed to the procedure. A single value is passed instead. This single value is a locator to the table, which the procedure uses to access the columns of the transition table. A procedure with a table parameter can only be invoked from the triggered action of a trigger.

The transition table includes columns that are defined as implicitly hidden in the table. The table that is identified can contain XML columns; however, the procedure cannot reference those XML columns.

For more information about the TABLE LIKE clause, see [TABLE LIKE](#). For more information about using table locators, see [Accessing transition tables in a user-defined function or stored procedure \(Db2 Application programming and SQL\)](#).

LANGUAGE

Specifies the application programming language in which the procedure is written.

SQL

The procedure is written in Db2 SQL procedural language.

FENCED

Specifies that the procedure runs in an external address space. FENCED also specifies that the SQL procedure program is an MVS load module with an external name.

DYNAMIC RESULT SETS *integer*

Specifies the maximum number of query result sets that the procedure can return. The default is DYNAMIC RESULT SETS 0, which indicates that the procedure can return no result sets. The value of *integer* must be in the range 0–32767.

PARAMETER CCSID

Indicates whether the encoding scheme for character and graphic string parameters is ASCII, EBCDIC, or UNICODE. The default encoding scheme is the value that is specified in the CCSID clauses of the parameter list or in the field DEF ENCODING SCHEME on installation panel DSNTIPF.

This clause provides a convenient way to specify the encoding scheme for character and graphic string parameters. If individual CCSID clauses are specified for individual parameters in addition to this PARAMETER CCSID clause, the value that is specified in *all* of the CCSID clauses must be the same value that is specified in this clause.

This clause also specifies the encoding scheme that is to be used for system-generated parameters of the routine such as message tokens and DBINFO.

PARAMETER VARCHAR

Specifies that the representation of the values of varying length character string-parameters for procedures that specify LANGUAGE C.

NULTERM

Specifies that variable length character string parameters are represented in a NUL-terminated string form.

NULTERM is the default.

STRUCTURE

Specifies that variable length character string parameters are represented in a VARCHAR structure form.

The PARAMETER VARCHAR clause only applies to parameters in the parameter list of a procedure and in the RETURNS clause. It does not apply to system-generated parameters of the routine such as message tokens and DBINFO.

In a data sharing environment, you should not specify the PARAMETER VARCHAR clause until all members of the data sharing group support the clause. If some group members support this clause

and others do not, and PARAMETER VARCHAR is specified, the routine will encounter different parameter forms depending on which group member invokes the routine.

EXTERNAL NAME 'string' or identifier

Specifies the name of the MVS load module for the program that runs when the procedure name is specified in an SQL CALL statement. The value must conform to the naming conventions for MVS load modules: the value must be less than or equal to 8 bytes, and it must conform to the rules for an ordinary identifier with the exception that it must not contain an underscore.

EXTERNAL NAME *procedure-name* is the default. In some cases, the default name will not be valid. To avoid an invalid name, specify EXTERNAL NAME for a procedure that has a name that is greater than 8 bytes in length, contains an underscore, or does not conform to the rules for an ordinary identifier.

NOT DETERMINISTIC or DETERMINISTIC

Specifies whether the procedure returns the same results each time the procedure is called with the same IN and INOUT arguments.

NOT DETERMINISTIC

The procedure might not return the same result each time the procedure is called with the same IN and INOUT arguments, even when the referenced data in the database has not changed.

NOT DETERMINISTIC is the default.

DETERMINISTIC

The procedure always returns the same results each time the stored procedure is called with the same IN and INOUT arguments, if the referenced data in the database has not changed.

Db2 does not verify that the procedure code is consistent with the specification of DETERMINISTIC or NOT DETERMINISTIC.

CALLED ON NULL INPUT

Specifies that the procedure is to be called even if any or all argument values are null, which means that the procedure must be coded to test for null argument values. The procedure can return null or non-null values.

CALLED ON NULL INPUT is the default.

MODIFIES SQL DATA, READS SQL DATA, or CONTAINS SQL

Specifies the classification of SQL statements and nested routines that this routine can execute or invoke. The database manager verifies that the SQL statements issued by the procedure, and all routines locally invoked by the routine, are consistent with this specification; the verification is not performed when nested remote routines are invoked. For the classification of each statement, see [Appendix D, "SQL statement data access classification for routines,"](#) on page 2275.

MODIFIES SQL DATA

Specifies that the procedure can execute any SQL statement except statements that are not supported in procedures.

MODIFIES SQL DATA is the default.

READS SQL DATA

Specifies that the procedure can execute statements with a data access indication of READS SQL DATA or CONTAINS SQL. The procedure cannot execute SQL statements that modify data.

CONTAINS SQL

Specifies that the procedure can execute only SQL statements with a data access indication of CONTAINS SQL. The procedure cannot execute statements that read or modify data.

NO DBINFO

Specifies that no additional status information that is known by Db2 is passed to the procedure when it is invoked.

NO COLLID or COLLID *collection-id*

Identifies the package collection that is to be used when the procedure is executed. This is the package collection into which the DBRM that is associated with the procedure is bound.

NO COLLID

Specifies that the package collection for the procedure is the same as the package collection of the calling program. If the invoking program does not use a package, Db2 resolves the package by using the CURRENT PACKAGE PATH special register, the CURRENT PACKAGESET special register, or the PKLIST bind option (in this order). For details about how Db2 uses these three items, see the information on package resolution in [Binding an application plan \(Db2 Application programming and SQL\)](#).

NO COLLID is the default.

COLLID *collection-id*

Specifies the package collection for the procedure.

WLM ENVIRONMENT *name* or (*name,)**

Identifies the WLM (workload manager) environment in which the stored procedure is to run when the Db2 stored procedure address space is WLM-established. The *name* of the WLM environment is an SQL identifier.

If you do not specify WLM ENVIRONMENT, the procedure runs in the default WLM-established stored procedure address space that is specified at installation time.

name

The WLM environment in which the procedure must run. If another procedure or a user-defined function calls the procedure and that calling routine is running in an address space that is not associated with the specified WLM environment, Db2 routes the procedure request to a different address space.

(*name,)**

When an SQL application program directly calls a procedure, *name* specifies the WLM environment in which the procedure runs.

If another procedure or a user-defined function calls the stored procedure, the procedure runs in the same WLM environment that the calling routine uses.

You must have appropriate authority for the WLM environment.

ASUTIME

Specifies the total amount of processor time, in CPU service units, that a single invocation of a procedure can run. The value is unrelated to the ASUTIME column of the resource limit specification table.

When you are debugging a procedure, setting a limit can be helpful in case the procedure gets caught in a loop. For information on service units, see [z/OS MVS Initialization and Tuning Guide](#).

NO LIMIT

There is no limit on the number of CPU service units that the procedure can run.

NO LIMIT is the default.

LIMIT *integer*

The limit on the number of CPU service units is a positive *integer* in the range 1–2147483647.

If the procedure uses more service units than the specified value, Db2 cancels the procedure.

The CPU cycles that are consumed by parallel tasks in a procedure do not contribute towards the specified ASUTIME LIMIT.

STAY RESIDENT

Specifies whether the load module for the procedure remains resident in memory when the procedure ends.

NO

The load module is deleted from memory after the procedure ends.

NO is the default.

YES

The load module remains resident in memory after the procedure ends.

PROGRAM TYPE

Specifies whether the procedure runs as a main routine or a subroutine.

MAIN

The procedure runs as a main routine.

MAIN is the default.

SUB

The procedure runs as a subroutine.

SECURITY

Specifies how the procedure interacts with an external security product, such as RACF, to control access to non-SQL resources.

Db2

The procedure does not require a special external security environment. If the procedure accesses resources that an external security product protects, the access is performed using the authorization ID that is associated with the address space in which the procedure runs.

Db2 is the default.

USER

An external security environment should be established for the procedure. If the procedure accesses resources that the external security product protects, the access is performed using the authorization ID of the user who invoked the procedure.

DEFINER

An external security environment should be established for the procedure. If the procedure accesses resources that the external security product protects, the access is performed using the authorization ID of the owner of the procedure.

RUN OPTIONS *run-time-options*

Specifies the Language Environment run time options that are to be used for the procedure. You must specify *run-time-options* as a character string that is no longer than 254 bytes. If you do not specify RUN OPTIONS or pass an empty string, Db2 does not pass any run time options to Language Environment, and Language Environment uses its installation defaults.

For a description of the Language Environment run time options, see [Language Environment Programming Reference \(z/OS Language Environment Programming Reference\)](#).

COMMIT ON RETURN

Indicates whether Db2 commits the transaction immediately on return from the procedure.

NO

Db2 does not issue a commit when the procedure returns.

NO is the default.

YES

Db2 issues a commit when the procedure returns if the following statements are true:

- A positive SQLCODE is returned by the CALL statement.
- The procedure is not in a must abort state.

The commit operation includes the work that is performed by the calling application process and the procedure.

If the procedure returns result sets, the cursors that are associated with the result sets must have been defined as WITH HOLD to be usable after the commit.

INHERIT SPECIAL REGISTERS or DEFAULT SPECIAL REGISTERS

Specifies how special registers are set on entry to the routine.

INHERIT SPECIAL REGISTERS

Specifies that the values of special registers are inherited, according to the rules that are listed in the table for characteristics of special registers in a procedure in [Table 47 on page 215](#).

INHERIT SPECIAL REGISTERS is the default.

DEFAULT SPECIAL REGISTERS

Specifies that special registers are initialized to the default values, as indicated by the rules in the table for characteristics of special registers in a procedure in [Table 47](#) on page 215.

STOP AFTER SYSTEM DEFAULT FAILURES, STOP AFTER *nn* FAILURES, or CONTINUE AFTER FAILURE

Specifies the routine is stopped after failures.

STOP AFTER SYSTEM DEFAULT FAILURES

Specifies that this routine should be placed in a stopped state after the number of failures indicated by the value of field MAX ABEND COUNT on installation panel DSNTIPX.

STOP AFTER SYSTEM DEFAULT FAILURES is the default.

STOP AFTER *nn* FAILURES

Specifies that this routine should be placed in a stopped state after *nn* failures. The value *nn* can be an integer 1–32767.

CONTINUE AFTER FAILURE

Specifies that this routine should not be placed in a stopped state after any failure.

SQL-routine-body

Specifies the statements that define the body of the SQL procedure. For information on the SQL control statements that are supported in external SQL procedures, see [Appendix E, “SQL control statements for external SQL procedures,”](#) on page 2279.

Notes for CREATE PROCEDURE (SQL - external)

Considerations for all types of procedures

For considerations that apply to all types of procedures, see [“CREATE PROCEDURE statement \(overview\)”](#) on page 1578.

Alternative syntax and synonyms

To provide compatibility with previous releases of Db2 or other products in the Db2 family, Db2 supports the following alternative syntax:

- RESULT SET and RESULT SETS as synonyms for DYNAMIC RESULT SETS
- VARIANT as a synonym for NOT DETERMINISTIC
- NOT VARIANT as a synonym for DETERMINISTIC

Examples for CREATE PROCEDURE (SQL - external)

Example 1

Create the definition for an SQL procedure. The procedure accepts an employee number and a multiplier for a pay raise as input. The following tasks are performed in the procedure body:

- Calculate the employee's new salary.
- Update the employee table with the new salary value.

```
CREATE PROCEDURE UPDATESALARY
  (IN EMPLOYEE_NUMBER CHAR(10),
  IN RATE DECIMAL(6,2))
LANGUAGE SQL
FENCED
EXTERNAL NAME 'USALARY1'
MODIFIES SQL DATA
UPDATE EMP
SET SALARY = SALARY * RATE
WHERE EMPNO = EMPLOYEE_NUMBER
```

Example 2

Create the definition for the SQL procedure described in example 1, but specify that the procedure has these characteristics:

- The procedure runs in a WLM environment called PARTSA.
- The same input always produces the same output.
- SQL work is committed on return to the caller.
- The Language Environment run time options to be used when the SQL procedure executes are 'MSGFILE(OUTFILE),RPTSTG(ON),RPTOPTS(ON)'.

```
CREATE PROCEDURE UPDATESALARY
  (IN EMPLOYEE_NUMBER CHAR(10),
  IN RATE DECIMAL(6,2))
LANGUAGE SQL
FENCED
EXTERNAL NAME 'USALARY2'
MODIFIES SQL DATA
WLM ENVIRONMENT PARTSA
DETERMINISTIC
RUN OPTIONS 'MSGFILE(OUTFILE),RPTSTG(ON),RPTOPTS(ON)'
COMMIT ON RETURN YES
UPDATE EMP
SET SALARY = SALARY * RATE
WHERE EMPNO = EMPLOYEE_NUMBER
```

For more examples of SQL procedures, see [Appendix E, “SQL control statements for external SQL procedures,”](#) on page 2279.

Related concepts

[Routines in Db2 for z/OS: functions and procedures \(Introduction to Db2 for z/OS\)](#)

[Naming conventions](#)

The rules for forming a name depend on the type of the object designated by the name.

Related tasks

[Migrating an external SQL procedure to a native SQL procedure \(Db2 Application programming and SQL\)](#)

[Creating external SQL procedures \(deprecated\) \(Db2 Application programming and SQL\)](#)

CREATE PROCEDURE statement (SQL - native procedure)

The CREATE PROCEDURE statement defines an SQL procedure, or a version of a procedure, at the current server and specifies the source statements for the procedure.

[FL 507](#)

If the OR REPLACE clause is specified and the procedure already exists:

- If the VERSION clause is not specified, the procedure definition is replaced.
- If the VERSION clause is specified and the identified version exists, the version is replaced. Otherwise the version is added to the procedure definition.

Native SQL procedures can contain SQL control statements. For information about the SQL control statements that are supported in native SQL procedures, refer to [Chapter 8, “SQL procedural language \(SQL PL\),”](#) on page 2207.

Invocation for CREATE PROCEDURE (SQL - native)

This statement can only be dynamically prepared, and the DYNAMICRULES run behavior must be specified implicitly or explicitly.

Authorization for CREATE PROCEDURE (SQL - native)

To create a new procedure in the implicit or explicit schema, the privilege set that is defined below must include at least one of the following:

- The CREATEIN privilege on the schema
- System DBADM authority
- SYSCTRL authority
- SYSADM authority
- Installation SYSOPR authority (when the current SQLID of the process is set to SYSINSTL)

The authorization ID that matches the schema name implicitly has the CREATEIN privilege on the schema.

FL 507To replace a procedure, the privilege set that is defined below must include at least one of the following:

- Ownership of the procedure
- Both the DROPIN and CREATEIN privilege on the schema
- System DBADM authority
- SYSCTRL authority
- SYSADM authority
- Installation SYSOPR authority (when the current SQLID of the process is set to SYSINSTL)

FL 507To add or replace a version of a procedure, the privilege set that is defined below must include at least one of the following:

- Ownership of the procedure
- The ALTERIN privilege on the schema
- System DBADM authority
- SYSCTRL authority
- SYSADM authority
- Installation SYSOPR authority (when the current SQLID of the process is set to SYSINSTL)

If a user-defined type is referenced (as the data type of a parameter or SQL variable), the privilege set must also include at least one of the following privileges or authorities:

- Ownership of the user-defined type
- The USAGE privilege on the user-defined type
- System DBADM authority
- DATAACCESS authority
- SYSADM authority

If the procedure uses a table as a parameter, the privilege set must also include at least one of the following privileges or authorities:

- Ownership of the table
- The SELECT privilege on the table
- DATAACCESS authority
- SYSADM authority

If you specify the WLM ENVIRONMENT FOR DEBUG MODE clause, RACF or an external security product is invoked to check the required authority for defining programs in the WLM environment. If the WLM environment access is protected in RACF, the privilege set must include the required authority.

To create or replace a procedure, or add or replace a version of a procedure, the privilege set must include the required authorization to add a new package or a new version of an existing package depending on the value of the BIND NEW PACKAGE field on installation panel DSNTPPP, or the privilege set must include SYSADM or SYSCTRL or system DBADM authority. The owner of the procedure package must have the privileges that are required to execute the statements in *SQL-routine-body*.

If the SECURED option is specified, at least one of the following privileges is required:

- SECADM authority
- CREATE_SECURE_OBJECT privilege

If the SEPARATE SECURITY subsystem parameter is set to NO, SYSADM authority has implicit SECADM authority.

Additional authorization might be required on the SYSDUMMYx tables depending on the content of the procedure definition. For more information, see [SYSDUMMYx tables \(Introduction to Db2 for z/OS\)](#).

If the authorization ID that is used to create the procedure has the installation SYSADM authority or the installation SYSOPR authority and if the current SQLID is set to SYSINSTL, the procedure is identified as system-defined procedure.

Privilege set:

The privilege set is the privileges that are held by the SQL authorization ID of the process unless the process is within a trusted context and the ROLE AS OBJECT OWNER clause is specified. In that case, the privileges set is the privileges that are held by the role that is associated with the primary authorization ID of the process.

When a CREATE PROCEDURE statement is issued in a trusted context that has the ROLE AS OBJECT OWNER clause, the package owner is determined as follows:

- If the PACKAGE OWNER option is not specified, the role associated with the binder becomes the package owner.
- If the PACKAGE OWNER option is specified, the role specified in the PACKAGE OWNER option becomes the package owner. In a trusted context, the specified PACKAGE OWNER must be a role.

Otherwise, the package owner is determined as follows:

- If the PACKAGE OWNER option is not specified, the procedure owner becomes the package owner.
- If the PACKAGE OWNER option is specified, the *authorization-name* specified in the PACKAGE OWNER option becomes the package owner.

Syntax for CREATE PROCEDURE (SQL - native)

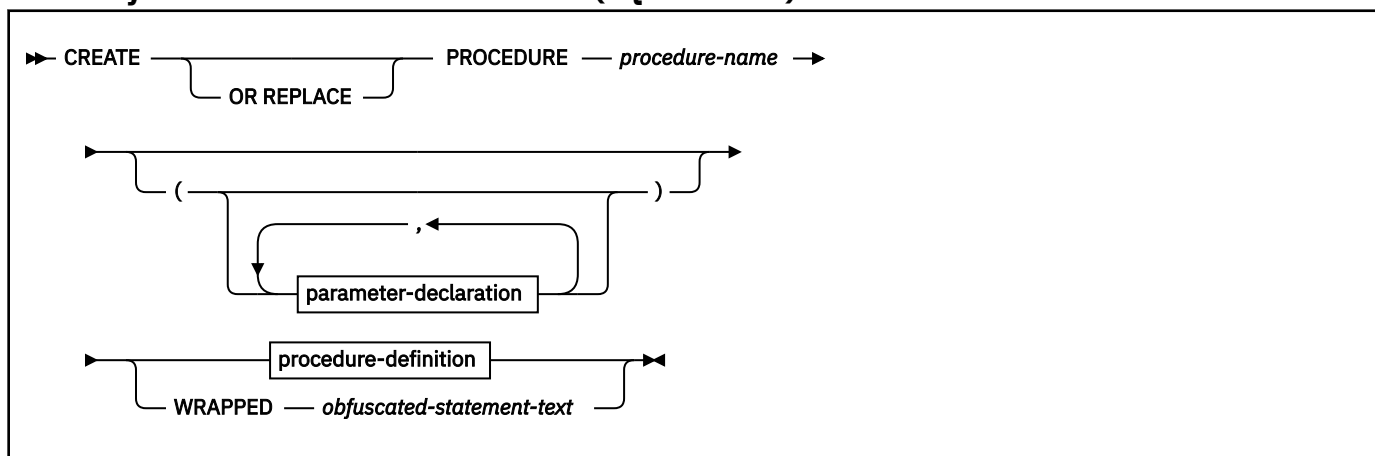

parameter-declaration:

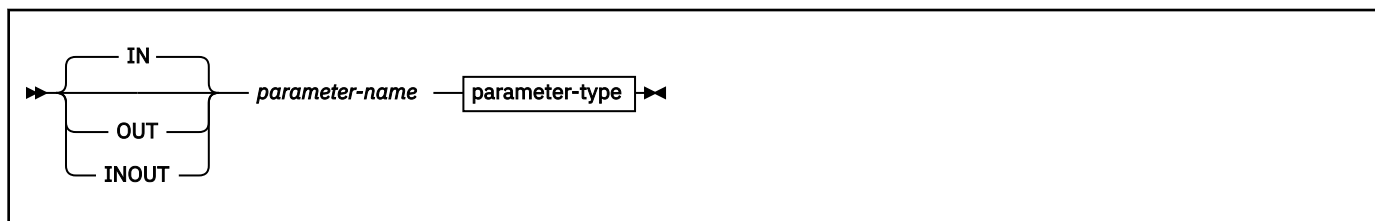

parameter-type:

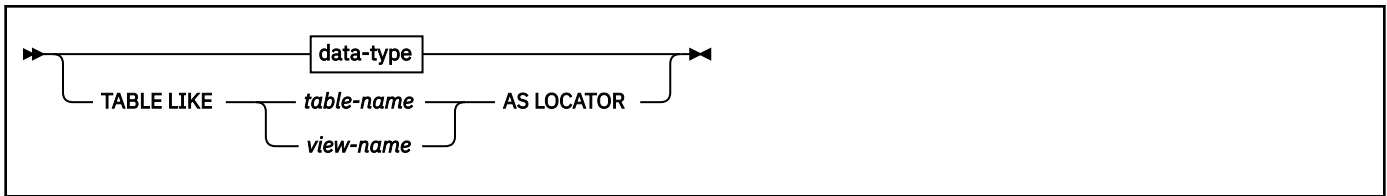

data-type:



built-in-type:

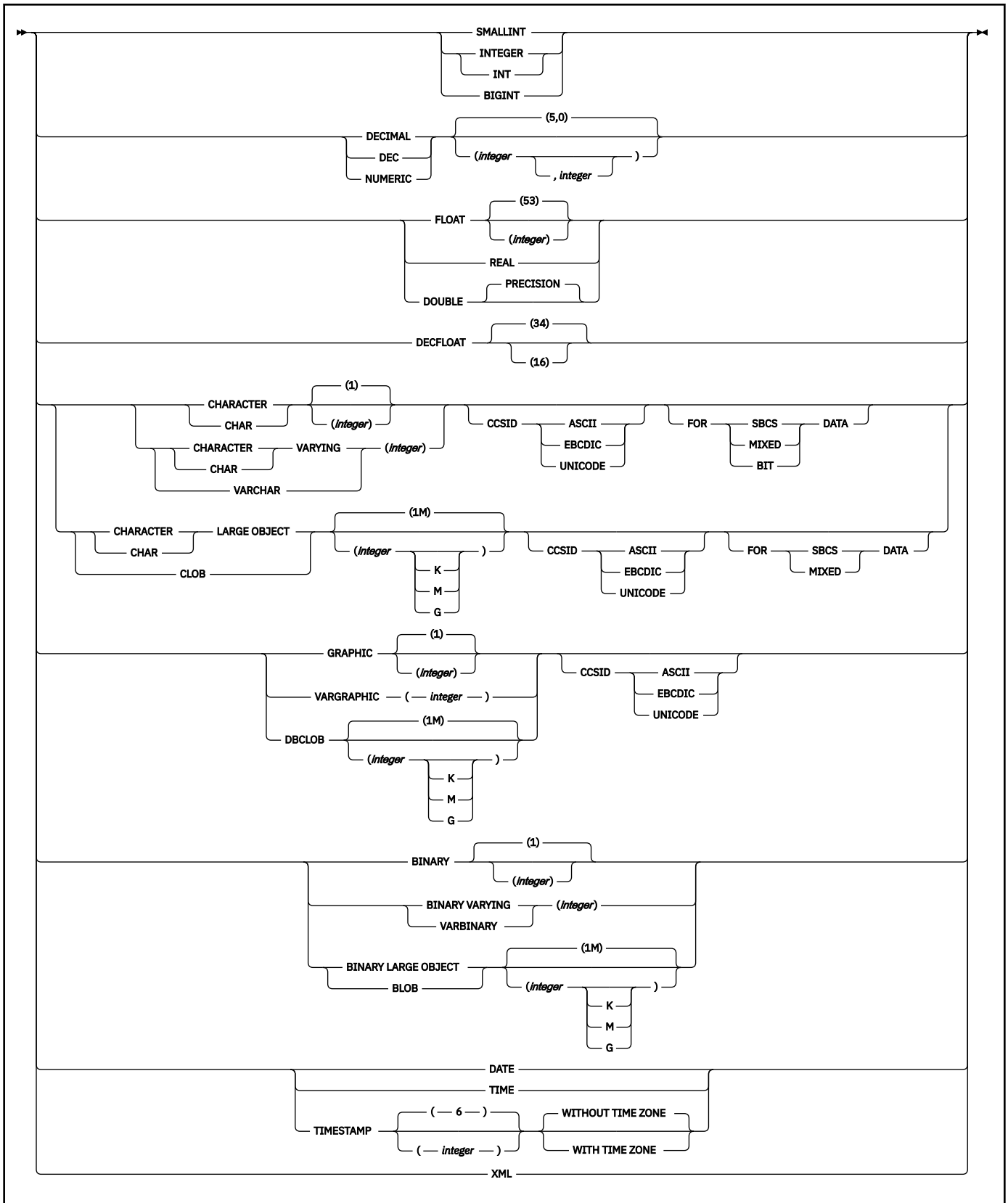

option-list: (The options can be specified in any order, but each one can only be specified one time.)

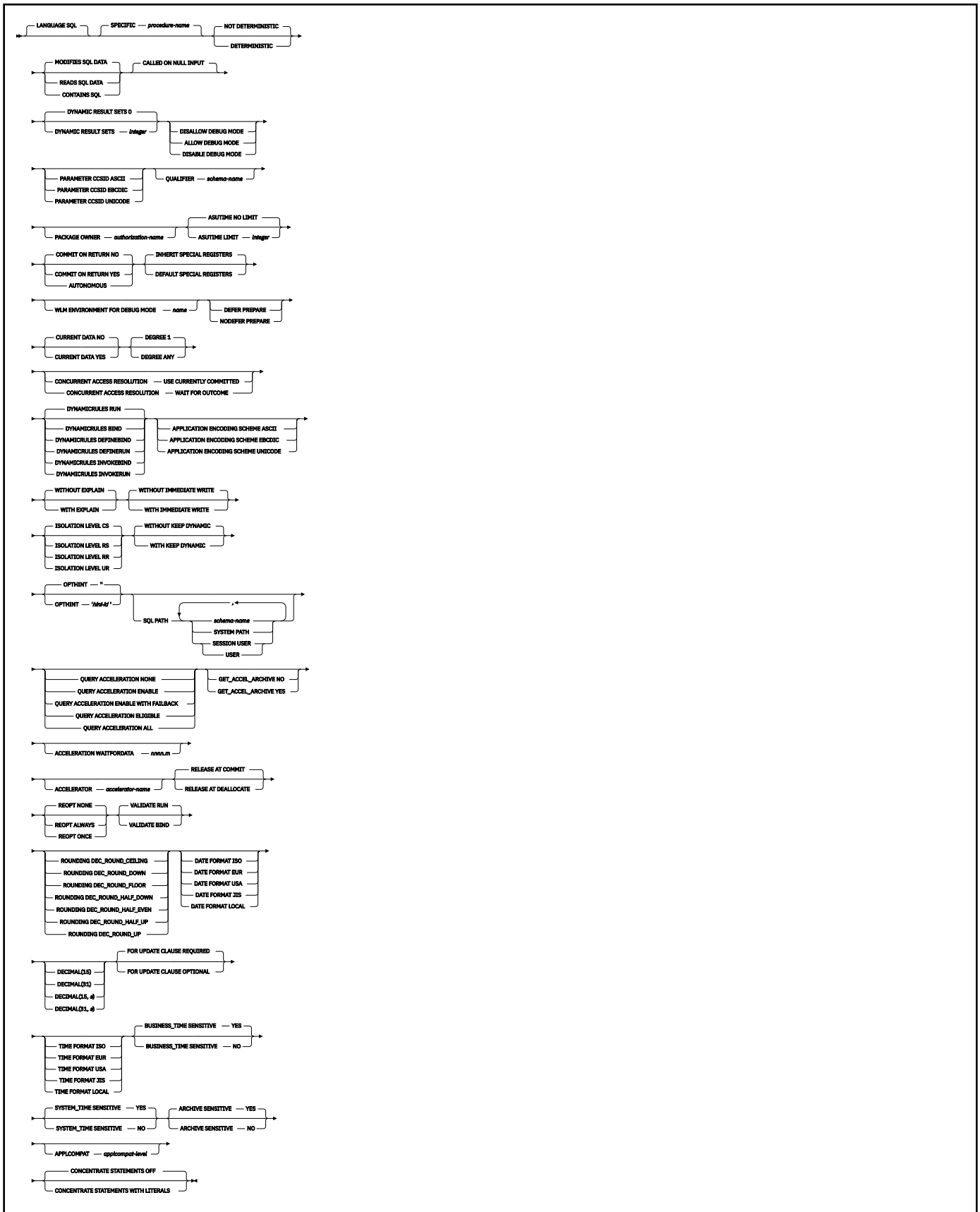

procedure-definition:

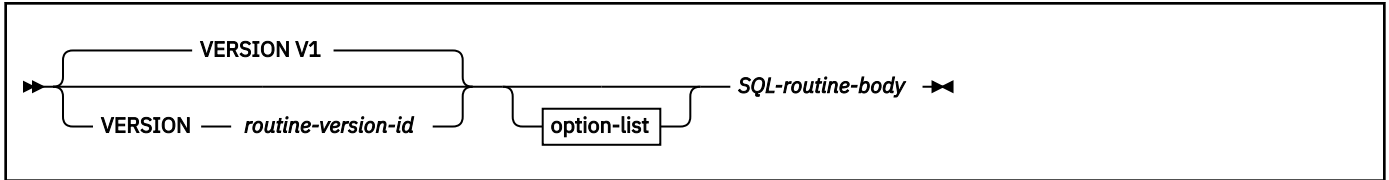

SQL-routine-body:

SQL-control-statement
ALTER DATABASE statement
ALTER FUNCTION statement (external scalar, external table, sourced, SQL scalar, or SQL table)
ALTER INDEX statement
ALTER PROCEDURE statement (external, SQL - external, or SQL - native)
ALTER SEQUENCE statement
ALTER STOGROUP statement
ALTER TABLE statement
ALTER TABLESPACE statement
ALTER TRUSTED CONTEXT statement
ALTER VIEW statement
COMMENT statement
COMMIT statement
CONNECT statement
CREATE ALIAS statement
CREATE DATABASE statement
CREATE FUNCTION statement (external scalar, external table, or sourced)
CREATE GLOBAL TEMPORARY TABLE statement
CREATE INDEX statement
CREATE PROCEDURE statement (external)
CREATE ROLE statement
CREATE SEQUENCE statement
CREATE STOGROUP statement
CREATE SYNONYM statement
CREATE TABLE statement
CREATE TABLESPACE statement
CREATE TRUSTED CONTEXT statement
CREATE TYPE statement
CREATE VIEW statement
DECLARE GLOBAL TEMPORARY TABLE statement
DELETE statement
DROP statement
EXCHANGE statement
EXECUTE IMMEDIATE statement
GRANT statement
INSERT statement
LABEL statement
LOCK TABLE statement
MERGE statement
REFRESH TABLE statement
RELEASE statement
RELEASE SAVEPOINT statement
RENAME statement
REVOKE statement
ROLLBACK statement
SAVEPOINT statement
SELECT INTO statement
SET CONNECTION statement
SET special-register statement
TRUNCATE statement
UPDATE statement
VALUES INTO statement

1

Notes:

¹ An ALTER FUNCTION statement (SQL scalar) or an ALTER PROCEDURE statement (SQL native) with an ADD VERSION or REPLACE clause are not allowed in an *SQL-routine-body*.

Description for CREATE PROCEDURE (SQL - native)

OR REPLACE

FL 507

Specifies that if the procedure exists at the current server, the existing definition is replaced, or that a version of the procedure is added or replaced. This option is ignored if a definition for the procedure does not exist at the current server. If a procedure exists with the specified name, the existing procedure must be a native SQL procedure.

If the procedure does not yet exist and the VERSION keyword is not specified, the procedure is created with the initial version of the procedure (V1).

If the procedure exists and the VERSION keyword is not specified, the procedure is replaced. The existing definition is dropped before the new definition is replaced in the catalog with the exception that the privileges that were granted on the procedure are not affected. The procedure is re-created as follows:

- Any existing comments are discarded
- The definition of the procedure can change
- The timestamp that is associated with the procedure definition is updated
- The owner of the procedure can change
- System default values are used for options that are not explicitly specified, even if those options were explicitly specified when the procedure that is being replaced was originally defined.

To replace an existing procedure, the procedure must not be defined with more than a single version, or with a single version for which the version id is other than V1. Additionally, one of the following conditions must be met:

- The SPECIFIC clause must be specified with the procedure name
- The signature of the new definition must match the signature of the existing procedure definition, except for parameter names

If the procedure exists with the specified version of the procedure, and the VERSION keyword is specified, the version is replaced in the catalog as if an ALTER PROCEDURE statement had been issued with the REPLACE VERSION clause. The procedure owner is not changed. Binding the replaced version of the procedure might result in a new access path even if the routine body is not changed.

When you replace a version of a procedure, the data types, CCSID specifications, and character data attributes (FOR BIT/SBCS/MIXED DATA) of the parameters must be the same as the attributes of the corresponding parameters for the currently active version of the procedure. The parameter list must not include a table parameter. For options that are not explicitly specified, the system default values for those options are used, even if those options were explicitly specified when the version of the procedure that is being replaced was originally defined. This is not the case for versions of the procedure that specified DISABLE DEBUG MODE. If DISABLE DEBUG MODE is specified for a version of a procedure, the option cannot be changed using a CREATE statement with the OR REPLACE clause.

If the procedure exists but version *routine-version-id* does not exist, and the VERSION keyword is specified, the specified version is created. *routine-version-id* is the version identifier for the new version of the procedure. The new version is defined as if an ALTER PROCEDURE statement had been issued with an ADD VERSION clause. The procedure owner is not changed. When a procedure definition is replaced, any existing comments in the catalog for that definition of the procedure are removed.

When you add a new version of a procedure, the data types, CCSID specifications, and character data attributes (FOR BIT/SBCS/MIXED DATA) of the parameters must be the same as the attributes of the corresponding parameters for the currently active version of the procedure. The parameter list must not include a table parameter. The parameter names can differ from the other versions of the procedure. For options that are not explicitly specified, the system default values are used.

procedure-name

FL 507

Names the procedure. The name, including the implicit or explicit schema name, must not identify a procedure that exists at the current server. However, you can specify an existing procedure name when the OR REPLACE keyword is also specified.

The name must not identify an existing wrapped procedure if the CREATE statement adds or replaces a version of that procedure.

The schema name can be 'SYSTOOLS' or 'SYSFUN' if the privilege set includes the SYSADM or SYSCtrl privilege. Otherwise, the schema name must not begin with 'SYS' unless the schema name is 'SYSADM', 'SYSIBMADM', or 'SYSPROC'.

(parameter-declaration,...)

Specifies the number of parameters of the procedure, the data type and usage of each parameter, and the name of each parameter for the version of the procedure that is being defined. The number of parameters and the specified data type and usage of each parameter must match the data types in the corresponding position of the parameter for all other versions of this procedure. Synonyms for data types are considered to be a match. All parameters are nullable.

IN, OUT, and INOUT specify the usage of the parameter. The usage of the parameters must match the implicit or explicit usage of the parameters of other versions of the same procedure.

IN

Identifies the parameter as an input parameter to the procedure. The value of the parameter on entry to the procedure is the value that is returned to the calling SQL application, even if changes are made to the parameter within the procedure.

IN is the default.

OUT

Identifies the parameter as an output parameter that is returned by the procedure. If the parameter is not set within the procedure, the null value is returned.

INOUT

Identifies the parameter as both an input and output parameter for the procedure. If the parameter is not set within the procedure, its input value is returned.

parameter-name

Names the parameter for use as an SQL variable. A parameter name cannot be the same as the name of any other parameter for this version of the procedure. The name of the parameter in this version of the procedure can be different than the name of the corresponding parameter for other versions of this procedure.

built-in-type

The data type of the parameter is a built-in data type.

For more information on the data types, including the subtype of character data types (the FOR *subtype* DATA clause), see "*built-in-type*" in "CREATE TABLE statement" on page 1650. However, the varying length string data types have different maximum lengths than for the CREATE TABLE statement. The maximum lengths for parameters (and SQL variables) are as follows: 32704 for VARCHAR or VARBINARY, and 16352 for VARGRAPHIC.

For parameters with a character or graphic data type, the PARAMETER CCSID clause or CCSID clause indicates the encoding scheme of the parameter. If you do not specify either of these clauses, the encoding scheme is the value of field DEF ENCODING SCHEME on installation panel DSNTIPF.

Although an input parameter with a character data type has an implicitly or explicitly specified subtype (BIT, SBCS, or MIXED), the value that is actually passed in the input parameter can have any subtype. Therefore, conversion of the input data to the subtype of the parameter might occur when the procedure is called. With ASCII or EBCDIC, an error occurs if mixed data that actually contains DBCS characters is used as the value for an input parameter that is declared with an SBCS subtype.

Parameters with a datetime data type or a distinct type are passed to the function as a different data type:

- A datetime type parameter is passed as a character data type, and the data is passed in ISO format. The encoding scheme for a datetime type parameter is the same as the implicitly or explicitly specified encoding scheme of any character or graphic string parameters. If no character or graphic string parameters are passed, the encoding scheme is the value of field DEF ENCODING SCHEME on installation panel DSNTIPF.
- A distinct type parameter is passed as the source type of the distinct type.

AS LOCATOR

Specifies that a locator to the value of the parameter is passed to the procedure instead of the actual value. Specify AS LOCATOR only for parameters with a LOB data type or a distinct type based on a LOB data type. Passing locators instead of values can result in fewer bytes being passed to the procedure, especially when the value of the parameter is very large.

The AS LOCATOR clause has no effect on determining whether data types can be promoted.

distinct-type-name

The data type of the input parameter is a distinct type. Any length, precision, scale, subtype, or encoding scheme attributes for the parameter are those of the source type of the distinct type. The distinct type must not be based on a LOB data type.

array-type-name

The data type of the input parameter is a user-defined array type.

If you specify *array-type-name* without a schema name, Db2 resolves the array type by searching the schemas in the SQL path.

TABLE LIKE *table-name* AS LOCATOR

Specifies that the parameter is a transition table. However, when the procedure is called, the actual values in the transition table are not passed to the procedure. A single value is passed instead. This single value is a locator to the table, which the procedure uses to access the columns of the transition table. The table that is identified can contain XML columns; however, the procedure cannot reference those XML columns. A procedure with a table parameter can only be invoked from the triggered action of a trigger.

The TABLE LIKE clause must not be specified when the CREATE statement adds or replaces a version of an existing procedure.

VERSION *routine-version-id*

Specifies the version identifier for the version of the procedure that is to be defined. See “[Naming conventions in SQL](#)” on page 79 for information about specifying *routine-version-id*. You can use an ALTER PROCEDURE statement with the ADD VERSION clause or the BIND DEPLOY command to create additional versions of the procedure.

V1 is the default version identifier.

Important: Do not create additional versions of procedures that are supplied with Db2 by specifying the VERSION keyword. Only versions that are supplied with Db2 are supported. Additional versions of such routines cause the installation and configuration of the supplied routines to fail.

LANGUAGE SQL

Specifies that the procedure is written in the Db2 SQL procedural language.

SPECIFIC *procedure-name*

FL 507

Specifies the procedure name as the specific name for the procedure. The name must be the same as the procedure name.

If you do not specify a schema name, it is the same as the explicit or implicit schema name of the procedure name (*procedure-name*). If you specify a schema name, it must be the same as the explicit or implicit schema name of the procedure name.

If you do not specify the SPECIFIC clause, the specific name is the name of the procedure. The specific name is stored in the SPECIFIC column of the SYSROUTINES catalog table.

Specify the SPECIFIC clause when replacing an existing procedure in the following situations:

- The parameter list of the existing procedure includes a table parameter.
- The CREATE statement specifies changes to the parameter list other than for parameter names.

DETERMINISTIC or NOT DETERMINISTIC

Specifies whether the procedure returns the same results each time it is called with the same IN and INOUT arguments.

DETERMINISTIC

The procedure always returns the same results each time it is called with the same IN and INOUT arguments if the data that is referenced in the database has not changed.

NOT DETERMINISTIC

The procedure might not return the same result each time it is called with the same IN and INOUT arguments, even when the data that is referenced in the database has not changed.

NOT DETERMINISTIC is the default.

Db2 does not verify that the procedure code is consistent with the specification of DETERMINISTIC or NOT DETERMINISTIC.

MODIFIES SQL DATA, READS SQL DATA, or CONTAINS SQL

Specifies the classification of SQL statements and nested routines that this routine can execute or invoke. The database manager verifies that the SQL statements issued by the procedure, and all routines locally invoked by the routine, are consistent with this specification; the verification is not performed when nested remote routines are invoked. For the classification of each statement, see [Appendix D, “SQL statement data access classification for routines,” on page 2275](#).

MODIFIES SQL DATA

Specifies that the procedure can execute any SQL statement except statements that are not supported in procedures.

MODIFIES SQL DATA is the default.

READS SQL DATA

Specifies that the procedure can execute statements with a data access indication of READS SQL DATA or CONTAINS SQL. The procedure cannot execute SQL statements that modify data.

CONTAINS SQL

Specifies that the procedure can execute only SQL statements with a data access indication of CONTAINS SQL. The procedure cannot execute statements that read or modify data.

CALLED ON NULL INPUT

Specifies that the procedure will be called if any, or even if all parameter values are null.

DYNAMIC RESULT SETS *integer*

Specifies the maximum number of query result sets that the procedure can return. The default is DYNAMIC RESULT SETS 0, which indicates that there are no result sets. The value must be in the range 0–32767.

ALLOW DEBUG MODE, DISALLOW DEBUG MODE, or DISABLE DEBUG MODE

Specifies whether this version of the routine can be run in debugging mode. The default is determined using the value of the CURRENT DEBUG MODE special register.

ALLOW DEBUG MODE

Specifies that this version of the routine can be run in debugging mode. When this version of the routine is invoked and debugging is attempted, a WLM environment must be available.

DISALLOW DEBUG MODE

Specifies that this version of the routine cannot be run in debugging mode.

You can use an ALTER statement to change this option to ALLOW DEBUG MODE for this initial version of the routine.

DISABLE DEBUG MODE

Specifies that this version of the routine can never be run in debugging mode.

This version of the routine cannot be changed to specify ALLOW DEBUG MODE or DISALLOW DEBUG MODE after this version of the routine has been created or altered to use DISABLE DEBUG MODE. To change this option, drop the routine and create it again using the option that you want. An alternative to dropping and recreating the routine is to create a version of the routine that uses the option that you want and making that version the active version.

When DISABLE DEBUG MODE is in effect, the WLM ENVIRONMENT FOR DEBUG MODE is ignored.

PARAMETER CCSID

Indicates whether the encoding scheme for character or graphic string parameters is ASCII, EBCDIC, or UNICODE. The default encoding scheme is the value that is specified in the CCSID clauses of the parameter list, or in the field DEF ENCODING SCHEME on installation panel DSNTIPF.

This clause provides a convenient way to specify the encoding scheme for character or graphic string parameters. If individual CCSID clauses are specified for individual parameters in addition to this PARAMETER CCSID clause, the value that is specified in all of the CCSID clauses must be the same value that is specified in this clause.

If the data type for a parameter is a user-defined distinct type that is defined as a character or graphic type string, the CCSID of the distinct type must be the same as the value that is specified in this clause.

If the data type for a parameter is a user-defined array type that is defined with character or graphic string array elements, or a character string array index, the CCSID of these array attributes must be the same as the value that is specified in this clause.

This clause also specifies the encoding scheme that will be used for system-generated parameters of the routine.

QUALIFIER *schema-name*

Specifies the implicit qualifier that is used for unqualified object names that are referenced in the procedure body. For information about how the default for this option is determined, see [“Unqualified alias, index, JAR file, mask, permission, sequence, table, trigger, and view names”](#) on page 86.

PACKAGE OWNER *authorization-name*

Specifies the owner of the package that is associated with the version of the routine. The SQL authorization ID of the process is the default value.

ASUTIME

Specifies the total amount of processor time, in CPU service units, that a single invocation of a routine can run. The value is unrelated to the ASUTIME column of the resource limit specification table.

When you are debugging a routine, setting a limit can be helpful in case the routine gets caught in a loop. For information on service units, see [z/OS MVS Initialization and Tuning Guide](#).

NO LIMIT

Specifies that there is no limit on the service units.

NO LIMIT is the default.

LIMIT *integer*

The limit on the number of CPU service units is a positive *integer* in the range 1–2 147 483 647.

If the procedure uses more service units than the specified value, Db2 cancels the procedure.

The CPU cycles that are consumed by parallel tasks in a procedure do not contribute towards the specified ASUTIME LIMIT.

COMMIT ON RETURN NO, COMMIT ON RETURN YES, or AUTONOMOUS

Indicates whether Db2 commits the transaction immediately on return from the procedure.

COMMIT ON RETURN NO

Db2 does not issue a commit when the procedure returns. NO is the default.

COMMIT ON RETURN YES,

Db2 issues a commit when the procedure returns if the following statements are true:

- The SQLCODE that is returned by the CALL statement is not negative.
- The procedure is not in a must-abort state.

The commit operation includes the work that is performed by the calling application process and by the procedure.

If the procedure returns result sets, the cursors that are associated with the result sets must have been defined as WITH HOLD to be usable after the commit.

AUTONOMOUS

Db2 executes the SQL procedure in a unit of work that is independent from the calling application. When this option is specified the procedure follows the rules of the COMMIT ON RETURN YES option before returning to the calling application. However, it does not commit changes in the calling application. When autonomous is specified:

- DYNAMIC RESULT SETS 0 must be in effect.
- Stored procedure parameters must not be defined as:
 - A LOB type
 - The XML data type
 - A distinct data type that is based on a LOB or XML value
 - An array type that is defined with array elements that are a LOB type

A value must not be assigned to a global variable when an autonomous procedure is executing.

INHERIT SPECIAL REGISTERS or DEFAULT SPECIAL REGISTERS

Specifies how special registers are set on entry to the routine.

INHERIT SPECIAL REGISTERS

Specifies that the values of special registers are inherited, according to the rules that are listed in the table for characteristics of special registers in a routine in [Table 47 on page 215](#).

INHERIT SPECIAL REGISTERS is the default.

DEFAULT SPECIAL REGISTERS

Specifies that special registers are initialized to the default values, as indicated by the rules in the table for characteristics of special registers in a routine in [Table 47 on page 215](#).

WLM ENVIRONMENT FOR DEBUG MODE *name*

Specifies the WLM (workload manager) application environment that is used by Db2 when debugging the routine. The *name* of the WLM environment is an SQL identifier.

If you do not specify WLM ENVIRONMENT FOR DEBUG MODE, Db2 uses the default WLM-established stored procedure address space specified at installation time.

You must have the appropriate authority for the WLM application environment.

The WLM ENVIRONMENT FOR DEBUG MODE value is ignored when DISABLE DEBUG MODE is in effect.

DEFER PREPARE or NODEFER PREPARE

Specifies whether to defer preparation of dynamic SQL statements that refer to remote objects, or to prepare them immediately.

The default depends on the value in effect for the REOPT option. If REOPT NONE is in effect, the default is inherited from the plan at run time. Otherwise, the default is DEFER PREPARE.

DEFER PREPARE

Specifies that the preparation of dynamic SQL statements that refer to remote objects will be deferred.

For considerations for distributed processing, see [DEFER and NODEFER bind options \(Db2 Commands\)](#).

NODEFER PREPARE

Specifies that the preparation of dynamic SQL statements that refer to remote objects will not be deferred.

CURRENT DATA YES or CURRENT DATA NO

Specifies whether to require data currency for read-only and ambiguous cursors when the isolation level of cursor stability is in effect. CURRENT DATA also determines whether block fetch can be used for distributed, ambiguous cursors.

CURRENT DATA YES

Specifies that data currency is required for read-only and ambiguous cursors. Db2 acquires page or row locks to ensure data currency. Block fetch is ignored for distributed, ambiguous cursors.

CURRENT DATA NO

Specifies that data currency is not required for read-only and ambiguous cursors. Block fetch is allowed for distributed, ambiguous cursors. Use of CURRENT DATA NO is not recommended if the routine attempts to dynamically prepare and execute a DELETE WHERE CURRENT OF statement against an ambiguous cursor after that cursor is opened. You receive a negative SQLCODE if your routine attempts to use a DELETE WHERE CURRENT OF statement for any of the following cursors:

- A cursor that is using block fetch
- A cursor that is using query parallelism
- A cursor that is positioned on a row that is modified by this or another application process

CURRENT DATA NO is the default.

DEGREE

Specifies whether to attempt to run a query using parallel processing to maximize performance.

1

Specifies that parallel processing should not be used.

1 is the default.

ANY

Specifies that parallel processing can be used.

CONCURRENT ACCESS RESOLUTION

Specifies the whether processing uses only committed data or whether it will wait for commit or rollback of data that is in the process of being updated.

WAIT FOR OUTCOME

Specifies that processing will wait for the commit or rollback of data that is in the process of being updated.

USE CURRENTLY COMMITTED

Specifies that processing use the currently committed version of the data when data that is in the process of being updated is encountered. USE CURRENTLY COMMITTED is applicable on scans that access tables that are defined in universal table spaces with row or page level lock size.

When there is lock contention between a read transaction and an insert transaction, USE CURRENTLY COMMITTED is applicable to scans with isolation level CS or RS. Applicable scans include intent read scans for read-only and ambiguous queries and for updatable cursors. USE CURRENTLY COMMITTED is also applicable to scans initiated from WHERE predicates of UPDATE or DELETE statements and the subselect of INSERT statements.

When there is lock contention is between a read transaction and a delete transaction, USE CURRENTLY COMMITTED is applicable to scans with isolation level CS and when CURRENT DATA NO is specified.

DYNAMICRULES

Specifies the values that apply, at run time, for the following dynamic SQL attributes:

- The authorization ID that is used to check authorization
- The qualifier that is used for unqualified objects

- The source for application programming options that Db2 uses to parse and semantically verify dynamic SQL statements

DYNAMICRULES also specifies whether dynamic SQL statements can include GRANT, REVOKE, ALTER, CREATE, DROP, and RENAME statements.

In addition to the value of the DYNAMICRULES clause, the run time environment of a routine controls how dynamic SQL statements behave at run time. The combination of the DYNAMICRULES value and the run time environment determines the value for the dynamic SQL attributes. That set of attribute values is called the dynamic SQL statement behavior. The following values can be specified:

RUN

Specifies that dynamic SQL statements are to be processed using run behavior.

RUN is the default.

BIND

Specifies that dynamic SQL statements are to be processed using bind behavior.

DEFINEBIND

Specifies that dynamic SQL statements are to be processed using either define behavior or bind behavior.

DEFINERUN

Specifies that dynamic SQL statements are to be processed using either define behavior or run behavior.

INVOKEBIND

Specifies that dynamic SQL statements are to be processed using either invoke behavior or bind behavior.

INVOKERUN

Specifies that dynamic SQL statements are to be processed using either invoke behavior or run behavior.

See For information on the effects of these options, see [“Authorization IDs and dynamic SQL”](#) on page 94.

APPLICATION ENCODING SCHEME

Specifies the default encoding scheme for SQL variables in static SQL statements in the routine body. The value is used for defining an SQL variable in a compound statement if the CCSID clause is not specified as part of the data type, and the PARAMETER CCSID routine option is not specified.

ASCII

Specifies that the data is encoded using the ASCII CCSIDs of the server.

EBCDIC

Specifies that the data is encoded using the EBCDIC CCSIDs of the server.

UNICODE

Specifies that the data is encoded using the Unicode CCSIDs of the server.

See the ENCODING bind option in [ENCODING bind option \(Db2 Commands\)](#) for information about how the default for this option is determined.

WITH EXPLAIN or WITHOUT EXPLAIN

Specifies whether information will be provided about how SQL statements in the routine will execute.

WITHOUT EXPLAIN

Specifies that information will not be provided about how SQL statements in the routine will execute.

You can get EXPLAIN output for a statement that is embedded in a routine that is specified using WITHOUT EXPLAIN by embedding the SQL statement EXPLAIN in the routine body. Otherwise, the value of the EXPLAIN option applies to all explainable SQL statements in the routine body, and to the fullselect portion of any DECLARE CURSOR statements.

WITHOUT EXPLAIN is the default.

WITH EXPLAIN

Specifies that information will be provided about how SQL statements in the routine will execute. Information is inserted into the table *owner*.PLAN_TABLE. *owner* is the authorization ID of the owner of the routine. Alternatively, the authorization ID of the owner of the routine can have an alias as *owner*.PLAN_TABLE that points to the base table, PLAN_TABLE. *owner* must also have the appropriate SELECT and INSERT privileges on that table. WITH EXPLAIN does not obtain information for statements that access remote objects. PLAN_TABLE must have a base table and can have multiple aliases with the same table name, PLAN_TABLE, but have different schema qualifiers. It cannot be a view or a synonym and should exist before the CREATE statement is processed. In all inserts to *owner*.PLAN_TABLE, the value of QUERYNO is the statement number that is assigned by Db2.

The WITH EXPLAIN option also populates two optional tables, if they exist: DSN_STATEMNT_TABLE and DSN_FUNCTION_TABLE. DSN_STATEMNT_TABLE contains an estimate of the processing cost for an SQL statement and DSN_FUNCTION_TABLE contains information about function resolution. For more information, see [EXPLAIN tables \(Db2 Performance\)](#).

For more information about the EXPLAIN statement, including a description of the tables that are populated by the WITH EXPLAIN option, see [“EXPLAIN statement” on page 1917](#).

WITH IMMEDIATE WRITE or WITHOUT IMMEDIATE WRITE

Specifies whether immediate writes are to be done for updates that are made to group buffer pool dependent page sets or partitions. This option is only applicable for data sharing environments. The IMMEDIATEWRITE subsystem parameter has no effect of this option. IMMEDIATEWRITE bind option ([Db2 Commands](#)) shows the implied hierarchy of the IMMEDIATEWRITE bind option (which is similar to this routine option) as it affects run time.

WITHOUT IMMEDIATE WRITE

Specifies that normal write activity is performed. Updated pages that are group buffer pool dependent are written at or before phase one of commit or at the end of abort for transactions that have been rolled back.

WITHOUT IMMEDIATE WRITE is the default.

WITH IMMEDIATE WRITE

Specifies that updated pages that are group buffer pool dependent are immediately written as soon as the buffer update completes. Updated pages are written immediately even if the buffer is updated during forward progress or during the rollback of a transaction. WITH IMMEDIATE WRITE might impact performance.

ISOLATION LEVEL RR, RS, CS, or UR

Specifies how far to isolate the routine from the effects of other running applications. For information about isolation levels, see [Choosing an ISOLATION option \(Db2 Performance\)](#).

RR

Specifies repeatable read.

RS

Specifies read stability.

CS

Specifies cursor stability. CS is the default.

UR

Specifies uncommitted read.

WITH KEEP DYNAMIC or WITHOUT KEEP DYNAMIC

Specifies whether Db2 keeps dynamic SQL statements after commit points.

WITHOUT KEEP DYNAMIC

Specifies that Db2 does not keep dynamic SQL statements after commit points.

WITHOUT KEEP DYNAMIC is the default.

WITH KEEP DYNAMIC

Specifies that Db2 keeps dynamic SQL statements after commit points. If you specify WITH KEEP DYNAMIC, the application does not need to prepare an SQL statement after every commit point. Db2 keeps the dynamic SQL statement until one of the following occurs:

- The application process ends
- A rollback operations occurs
- The application executes an explicit PREPARE statement with the same statement identifier as the dynamic SQL statement

If you specify WITH KEEP DYNAMIC, and the dynamic statement cache is active, the Db2 subsystem keeps a copy of the prepared statement in the cache. If the dynamic statement cache is not active, the subsystem keeps only the SQL statement string past a commit point. If the application executes an OPEN, EXECUTE, or DESCRIBE operation for that statement, the statement is implicitly prepared.

If you specify WITH KEEP DYNAMIC, DDF server threads that are used to execute procedures or packages that have this option in effect will remain active. Active DDF server threads are subject to idle thread timeout. For more information see [IDLE THREAD TIMEOUT field \(IDTHTOIN subsystem parameter\)](#) (Db2 Installation and Migration).

If you specify WITH KEEP DYNAMIC, you must not specify REOPT ALWAYS. WITH KEEP DYNAMIC and REOPT ALWAYS are mutually exclusive. However, you can specify WITH KEEP DYNAMIC and REOPT ONCE.

Use WITH KEEP DYNAMIC to improve performance if your DRDA client application uses a cursor that is defined as WITH HOLD. The Db2 subsystem automatically closes a held cursor when there are no more rows to retrieve, which eliminates an extra network message.

OPTHINT '*hint-id*'

Specifies whether query optimization hints are used for static SQL statements that are contained within the body of the routine.

hint-id is a character string of up to 128 bytes in length, which is used by the Db2 subsystem when searching the PLAN_TABLE for rows to use as input. The default value is an empty string (''), which indicates that the Db2 subsystem does not use optimization hints for static SQL statements.

Optimization hints are only used if optimization hints are enabled for your system. For more information, see [OPTIMIZATION HINTS field \(OPTHINTS subsystem parameter\)](#) (Db2 Installation and Migration).

SQL PATH

Specifies the SQL path that Db2 uses to resolve unqualified user-defined type, function, and procedure names in static SQL statements in the procedure body.

This option does not apply to dynamic SQL statements in the procedure body. Db2 uses the CURRENT PATH special register value to resolve unqualified user-defined type, function, and procedure names in dynamic SQL statements.

The default value for SQL PATH is "SYSIBM", "SYSFUN", "SYSPROC", "SYSIBMADM", and the value of the QUALIFIER option, which is the qualifier for the procedure that is the target of the statement.

Schemas "SYSIBM", "SYSFUN", "SYSPROC", "SYSIBMADM" do not need to be explicitly specified. If any of these schemas is not explicitly specified, it is implicitly assumed at the beginning the SQL path.

Db2 calculates the length by taking each *schema-name* specified and removing any trailing blanks from it, adding two delimiters around it, and adding one comma after each schema name except for the last one. The length of the resulting string cannot exceed the length of the CURRENT SCHEMA special register. If you do not specify the "SYSIBM", "SYSFUN", "SYSPROC", "SYSIBMADM", schemas, they are not included in the length of the SQL path. If the total length of the SQL path exceeds the length of the CURRENT PATH special register, Db2 returns an error for the CREATE statement.

For more information, see the following related topics:

- [“SQL path” on page 85](#)
- [PATH bind option \(Db2 Commands\)](#)
- [“CURRENT PATH special register” on page 200](#)
- [“CURRENT SCHEMA special register” on page 206](#)

schema-name

Specifies a schema. Db2 does not validate that the specified schema actually exists when the CREATE statement is processed.

SYSPUBLIC must not be specified for the SQL path.

schema-name-list

Specifies a comma separated list of schema names. The same schema name should not appear more than one time in the list of schema names. The number of schema names that you can specify is limited by the maximum length of the resulting SQL path.

SYSPUBLIC must not be specified for the SQL path.

SYSTEM PATH

Specifies the schema names "SYSIBM", "SYSFUN", "SYSPROC", "SYSIBMADM".

SESSION_USER or USER

Specifies the value of the SESSION_USER or USER special register, which represents a maximum 8 byte (in EBCDIC) *schema-name*. At the time the CREATE statement is processed, this length is included in the total length of the list of schema names that is specified for the PATH bind option.

RELEASE AT

Specifies when to release resources that the procedure uses: either at each commit point or when the procedure terminates.

COMMIT

Specifies that resources will be released at each commit point.

COMMIT is the default.

DEALLOCATE

Specifies that resources will be released only when the thread terminates. DEALLOCATE has no effect on dynamic SQL statements, which always use RELEASE AT COMMIT, with this exception: When you use the RELEASE AT DEALLOCATE clause and the WITH KEEP DYNAMIC clause, and the subsystem is installed with a value of YES for the field CACHE DYNAMIC SQL on installation panel DSNTIP8, the RELEASE AT DEALLOCATE option is honored for dynamic SELECT and data change statements.

Locks that are acquired for dynamic statements are held until one of the following events occurs:

- The application process ends.
- The application process issues a PREPARE statement with the same statement identifier. (Locks are released at the next commit point).
- The statement is removed from the dynamic statement cache because the statement has not been used. (Locks are released at the next commit point).
- An object that the statement is dependent on is dropped or altered, or a privilege that the statement needs is revoked. (Locks are released at the next commit point).

RELEASE AT DEALLOCATE can increase the package or plan size because additional items become resident in the package or plan.

For more information, see [Choosing a RELEASE option \(Db2 Performance\)](#).

REOPT

Specifies if Db2 will determine the access path at run time by using the values of SQL variables or SQL parameters, parameter markers, and special registers.

NONE

Specifies that Db2 does not determine the access path at run time by using the values of SQL variables or SQL parameters, parameter markers, and special registers.

NONE is the default.

ALWAYS

Specifies that Db2 always determines the access path at run time each time an SQL statement is run. Do not specify REOPT ALWAYS with the WITH KEEP DYNAMIC or NODEFER PREPARE clauses.

ONCE

Specifies that Db2 determine the access path for any dynamic SQL statements only once, at the first time the statement is opened. This access path is used until the prepared statement is invalidated or removed from the dynamic statement cache and need to be prepared again.

QUERY ACCELERATION

Specifies whether a static SQL query is bound for acceleration, and if so, with what behavior.

NONE

Specifies that no static SQL query in the application is bound for acceleration or will be accelerated when the application is run.

ENABLE

Specifies that a static SQL query is bound for acceleration if it satisfies the acceleration criteria, including the cost and heuristics criteria. The query is routed to an accelerator when the application runs. Otherwise, if the static query does not satisfy the acceleration criteria, the query is bound for execution in Db2.

If an error condition, such as one of the following examples, occurs while executing the accelerated static query when the application is run, Db2 fails the static query and returns a negative SQL code to the application:

- A failure occurs while running the static query on the accelerator.
- The accelerator returns an error for the query.
- The accelerator is not started and Db2 cannot route the static query to the accelerator for execution.

ENABLE WITH FAILBACK

Results in the same behavior as ENABLE, except if one of the error conditions occurs on the first OPEN of the accelerated static query when the application is run. In this case, instead of failing the static query and returning a negative SQL code to the application, Db2 performs a temporary *statement-level* incremental bind of the query and runs the query in Db2. The application does not see the acceleration failure. Failback to Db2 is not possible after the application does a successful OPEN for the query on the accelerator.

ELIGIBLE

Specifies that a static SQL query is bound for acceleration if the query meets the basic acceleration criteria, regardless of the cost or heuristics criteria. The query is routed to the accelerator when the application runs.

Like the behavior for ENABLE, if an error condition occurs while executing the accelerated static query when the application is run, Db2 fails the static query and returns a negative SQL code to the application.

ALL

Specifies that all of the static SQL queries in the application are to be bound for acceleration and routed to the accelerator when the application runs. If Db2 determines that a static query cannot be bound to run on the accelerator and the query references a user base table or view, the BIND or REBIND PACKAGE operation fails with an error message for that query. (A failure exception is made for declared global temporary tables (DGTs) and created global temporary tables and (CGTs) because these tables cannot be accelerated.)

Like the behavior for ENABLE, if an error condition occurs while executing the accelerated static query when the application is run, Db2 fails the static query and returns a negative SQL code to the application.

This bind option does not apply to a *fullselect* or *WITH common-table-expression* that is specified in a RETURN statement for the routine, or in a SET *host-variable-assignment* that is used in the routine. The queries that are specified in these cases cannot be accelerated.

GET_ACCEL_ARCHIVE

Specifies whether a static SQL query that is bound for acceleration retrieves archived data on the accelerator, instead of active data.

NO

Specifies that no static SQL query is bound to retrieve archived data from the accelerator. If the static query also is not bound for acceleration, the query is bound to run in Db2.

If the static query is bound for acceleration because the QUERYACCELERATION bind option was specified, the query is routed to the accelerator when the application runs; however, the query does not retrieve any archived data.

YES

Specifies that if all of the following criteria are met, the query is bound for acceleration and retrieves the archived data on the accelerator when the application runs:

- The QUERYACCELERATION bind option is also specified.
- The static SQL query references an accelerated table that has partitioned data archived on an accelerator.
- The static query satisfies the acceleration criteria that is specified by the QUERYACCELERATION bind option.

If the static query does not satisfy the acceleration criteria that is specified by the QUERYACCELERATION bind option, the BIND or REBIND PACKAGE operation fails with an error message for that query.

This bind option does not apply to a *fullselect* or *WITH common-table-expression* that is specified in a RETURN statement for the routine, or in a SET *host-variable-assignment* that is used in the routine. The queries that are specified in these cases cannot be accelerated.

ACCELERATION WAITFORDATA

Specifies the maximum amount of time, if any, that an accelerator will delay a query while the accelerator waits for the replication of committed Db2 data changes that occurred prior to Db2 running the query.

For static accelerated queries, you must also set the QUERYACCELERATION bind option for this function or procedure to a valid value other than NONE to request that static queries be accelerated. If the QUERYACCELERATION bind option value is set to NONE, the ACCELERATIONWAITFORDATA bind option is accepted and the package is bound with the option value; however, the option will not apply to static SQL queries because no static queries will be accelerated.

For dynamic accelerated queries, specifying the ACCELERATION WAITFORDATA bind option also initializes the CURRENT QUERY ACCELERATION WAITFORDATA special register, which is used for the dynamic queries in the Db2 function or procedure if the function or procedure option DEFAULT SPECIAL REGISTERS is also used. Initializing CURRENT QUERY ACCELERATION WAITFORDATA to a value greater than 0 specifies that Db2 and the accelerator will apply WAITFORDATA delay behavior and restrictions to all dynamic SQL queries to be accelerated from the Db2 function or procedure. The CURRENT QUERY ACCELERATION special register must also have a valid value other than NONE to request that dynamic queries be accelerated.

nnnn.m

Specifies a DECIMAL(5,1) numeric-constant value that specifies the maximum number of seconds that the accelerator will delay a query while the accelerator waits for the replication of committed Db2 data changes that occurred prior to Db2 running the query.

You can specify a value in the range of 0.0–3600.0 seconds. For example, a value of 20.0 represents 20.0 seconds (or 20000 milliseconds), and a value of 30.5 represents 30.5 seconds (or 30500 milliseconds). The maximum value of 3600.0 means they the query is delayed for 3600 seconds.

You can also specify the value as an INTEGER numeric-constant value ranging 0–3600 seconds, which Db2 will convert to a DECIMAL(5,1) value.

Important: When a non-zero value is specified for the ACCELERATIONWAITFORDATA bind option, Db2 and the accelerator will apply other WAITFORDATA delay behaviors, restrictions, and requirements to all queries that will be accelerated from the application package. These behaviors, restrictions, and requirements can cause queries that were formerly accelerated successfully to no longer be accelerated or to fail. See [“SET CURRENT QUERY ACCELERATION WAITFORDATA statement”](#) on page 2150 for more information about WAITFORDATA behaviors, restrictions, and requirements.

ACCELERATOR

Specifies an accelerator server that, if enabled and available, Db2 will consider as the preferred accelerator for eligible SQL queries before sending the queries to other accelerator servers. If the specified accelerator server is not enabled or available, Db2 will send the queries to other available accelerator servers.

VALIDATE RUN or VALIDATE BIND

Specifies whether to recheck, at run time, errors of the type "OBJECT NOT FOUND" and "NOT AUTHORIZED" that are found during bind or rebind. The option has no effect if all objects and needed privileges exist.

VALIDATE RUN

Specifies that if needed objects or privileges do not exist when the CREATE statement is processed, warning messages are returned, but the CREATE statement succeeds. The Db2 subsystem rechecks for the objects and privileges at run time for those SQL statements that failed the checks during processing of the CREATE statement. The authorization checks the use of the authorization ID of the owner of the routine.

VALIDATE RUN is the default.

VALIDATE BIND

Specifies that if needed objects or privileges do not exist at the time the CREATE statement is processed, an error is issued and the CREATE statement fails.

ROUNDING

Specifies the rounding mode for manipulation of DECFLOAT data. The default value is taken from the DEFAULT DECIMAL FLOATING POINT ROUNDING MODE in DECP.

DEC_ROUND_CEILING

Specifies numbers are rounded towards positive infinity.

DEC_ROUND_DOWN

Specifies numbers are rounded towards 0 (truncation).

DEC_ROUND_FLOOR

Specifies numbers are rounded towards negative infinity.

DEC_ROUND_HALF_DOWN

Specifies numbers are rounded to nearest; if equidistant, round down.

DEC_ROUND_HALF_EVEN

Specifies numbers are rounded to nearest; if equidistant, round so that the final digit is even.

DEC_ROUND_HALF_UP

Specifies numbers are rounded to nearest; if equidistant, round up.

DEC_ROUND_UP

Specifies numbers are rounded away from 0.

DATE FORMAT ISO, EUR, USA, JIS, or LOCAL

Specifies the date format for result values that are string representations of date or time values. For more information, see [“String representations of datetime values” on page 120](#).

The default format is specified in the DATE FORMAT field of installation panel DSNTIP4 of the system where the routine is defined. You cannot use the LOCAL option unless you have a date exit routine.

DECIMAL (15), DECIMAL (31), DECIMAL (15, s), or DECIMAL (31, s)

Specifies the maximum precision that is to be used for decimal arithmetic operations. For more information see [“Arithmetic with two decimal operands” on page 251](#). The default format is specified in the DECIMAL ARITHMETIC field of installation panel DSNTIPF of the system where the routine is defined. If the form *pp.s* is specified, *s* must be a number in the range 1–9. *s* represents the minimum scale that is to be used for division.

FOR UPDATE CLAUSE OPTIONAL or FOR UPDATE CLAUSE REQUIRED

Specifies whether the FOR UPDATE clause is required for a DECLARE CURSOR statement if the cursor is to be used to perform positioned updates.

FOR UPDATE CLAUSE REQUIRED

Specifies that a FOR UPDATE clause must be specified as part of the cursor definition if the cursor will be used to make positioned updates.

[FOR UPDATE CLAUSE REQUIRED](#) is the default.

FOR UPDATE CLAUSE OPTIONAL

Specifies that the FOR UPDATE clause does not need to be specified in order for a cursor to be used for positioned updates. The routine body can include positioned UPDATE statements that update columns that the user is authorized to update.

The FOR UPDATE clause with no column list applies to static or dynamic SQL statements. Even if you do not use this clause, you can specify FOR UPDATE OF with a column list to restrict updates to only the columns that are identified in the FOR UPDATE clause and to specify the acquisition of update locks.

TIME FORMAT ISO, EUR, USA, JIS, or LOCAL

Specifies the time format for result values that are string representations of date or time values. For more information, see [“String representations of datetime values” on page 120](#).

The default format is specified in the TIME FORMAT field of installation panel DSNTIP4 of the system where the routine is defined. You cannot use the LOCAL option unless you have a date exit routine.

BUSINESS_TIME SENSITIVE

Determines whether references to application-period temporal tables in both static and dynamic SQL statements are affected by the value of the CURRENT TEMPORAL BUSINESS_TIME special register.

YES

References to application-period temporal tables are affected by the value of the CURRENT TEMPORAL BUSINESS_TIME special register. YES is the default value.

NO

References to application-period temporal tables are not affected by the value of the CURRENT TEMPORAL BUSINESS_TIME special register.

For more information, see [“.CURRENT TEMPORAL BUSINESS_TIME special register” on page 208](#)

SYSTEM_TIME SENSITIVE

Determines whether references to system-period temporal tables in both static and dynamic SQL statements are affected by the value of the CURRENT TEMPORAL SYSTEM_TIME special register.

YES

References to system-period temporal tables are affected by the value of the CURRENT TEMPORAL SYSTEM_TIME special register. YES is the default value.

NO

References to system-period temporal tables are not affected by the value of the CURRENT TEMPORAL SYSTEM_TIME special register.

For more information, see [“CURRENT TEMPORAL SYSTEM_TIME special register”](#) on page 210.

ARCHIVE SENSITIVE

Determines whether references to archive-enabled tables in SQL statements are affected by the value of the SYSIBMADM.GET_ARCHIVE built-in global variable.

YES

References to archive-enabled tables are affected by the value of the SYSIBMADM.GET_ARCHIVE built-in global variable. YES is the default value.

NO

References to archive-enabled tables are not affected by the value of the SYSIBMADM.GET_ARCHIVE built-in global variable.

For related information, see [“GET_ARCHIVE”](#) on page 330

APPLCOMPAT *applcompat-level*

Specifies the application compatibility level behavior for static SQL statements in the procedure body. If this option is not specified, the behavior is determined by the APPLCOMPAT subsystem parameter.

The following *applcompat-level* values can be specified:

VvvRrMmmm

Compatibility with the behavior of the identified Db2 function level. For example, V12R1M510 specifies compatibility with the highest available Db2 12 function level. The equivalent function level or higher must be activated.

For the new capabilities that become available in each application compatibility level, see:

- [SQL changes in Db2 13 application compatibility levels](#)
- [SQL changes in Db2 12 application compatibility levels](#)

Tip: Extra program preparation steps might be required to increase the application compatibility level for applications that use data server clients or drivers to access Db2 for z/OS. For more information, see [Setting application compatibility levels for data server clients and drivers \(Db2 Application programming and SQL\)](#).

V12R1

Compatibility with the behavior of Db2 12 function level 500. This value has the same result as specifying V12R1M500.

V11R1

Compatibility with the behavior of Db2 11 new-function mode. After migration to Db2 12, this value has the same result as specifying V12R1M100. For more information, see [V11R1 application compatibility level \(Db2 Application programming and SQL\)](#)

V10R1

Compatibility with the behavior of DB2 10 new-function mode. For more information, see [V10R1 application compatibility level \(Db2 Application programming and SQL\)](#).

CONCENTRATE STATEMENTS OFF or CONCENTRATE STATEMENTS WITH LITERALS

Specifies whether each dynamic SQL statement in the routine that specifies literal constants will be cached as a separate unique statement entry in the dynamic statement cache, instead of sharing an existing statement in the cache. Dynamic SQL statements are eligible to share an existing statement in the cache if the new statement meets all of the conditions for sharing a cached version of the same dynamic statement, except that the new statement specifies one or more literal constants that are different than the cached statement.

CONCENTRATE STATEMENTS OFF

Specifies that each dynamic SQL statement that specifies literal constants will be cached as a unique statement entry if it specifies one or more constants that are different than the cached version of the same dynamic statement. CONCENTRATE STATEMENTS OFF is the default dynamic statement caching behavior.

CONCENTRATE STATEMENTS WITH LITERALS

Specifies that each dynamic SQL statement that specifies literal constants will share a cached version of the same dynamic statement that is also prepared using the CONCENTRATE STATEMENTS WITH LITERALS option, if the new dynamic statement meets all of the conditions for sharing the cached statement, and the constants that are specified can be reused in place of the constants in the cached statement.

SQL-routine-body

Specifies the statements that define the body of the SQL procedure. For information on the SQL control statements that are supported in native SQL procedures, see [Chapter 8, “SQL procedural language \(SQL PL\),” on page 2207](#). If an *SQL-procedure-statement* is the only statement in the procedure body, the statement must not end with a semicolon.

WRAPPED obfuscated-statement-text

Specifies the encoded definition of the function. A CREATE PROCEDURE statement can be encoded using the WRAP scalar function.

WRAPPED must not be specified on a static CREATE statement, or a CREATE statement that adds or replaces a version of an existing procedure.

Notes for CREATE PROCEDURE (SQL - native)

Considerations for all types of procedures

For considerations that apply to all types of procedures, see [“CREATE PROCEDURE statement \(overview\)” on page 1578](#).

Error handling in SQL procedures

You should consider the possible exceptions that can occur for each SQL statement in the body of a procedure. Any exception SQLSTATE that is not handled within the procedure using a handler within a compound statement results in the exception SQLSTATE being returned to the caller of the procedure.

Versions of a procedure

[FL 507](#)The CREATE PROCEDURE statement for an SQL procedure defines the initial version of the procedure. You can define an additional version using the ADD VERSION clause of the ALTER PROCEDURE statement, or the CREATE PROCEDURE statement with the OR REPLACE clause and the VERSION clause when the procedure already exists. You can replace a version using the REPLACE VERSION clause of the ALTER PROCEDURE, or the CREATE PROCEDURE statement with the OR REPLACE clause and the VERSION clause when the procedure version already exists.

The data types, CCSID specifications and character data attributes (FOR BIT/SBCS/MIXED DATA) of the parameters must be the same as the attributes of the corresponding parameters for the currently active version of the procedure, unless the OR REPLACE is specified and the VERSION keyword is not specified.

Important: Do not create additional versions of procedures that are supplied with Db2 by specifying the VERSION keyword. Only versions that are supplied with Db2 are supported. Additional versions of such routines cause the installation and configuration of the supplied routines to fail.

Considerations for an existing procedure that is defined using a TABLE LIKE name AS LOCATOR clause

[FL 507](#)If an existing native SQL procedure is defined with a table parameter (the TABLE LIKE *name* AS LOCATOR clause was specified in the original CREATE PROCEDURE statement to indicate that one of the parameters is a transition table), the procedure cannot be changed with a CREATE PROCEDURE statement to add or replace a version of the procedure. In this case, the procedure must be dropped and re-created.

Characteristics of the package that is generated for a procedure

The package that is associated with the first version of a procedure is named as follows:

- *location* is set to the value of the CURRENT SERVER special register
- *collection-id* (schema) for the package is the same as the schema qualifier of the procedure.
- *package-id* is the same as the specific name of the procedure

- *version-id* is the same as the version identifier for the initial version of the procedure.

If you want to change the *collection-id* for the name of the package, you need to make a copy of the package.

The package is generated using the bind options that correspond to the implicitly or explicitly specified procedure options. For more information, see the table in “Correspondence of procedure options to BIND options” on page 1632. In addition to the corresponding bind options, the package is generated using the following bind options:

- DBPROTOCOL(DRDA)
- FLAG(1)
- SQLERROR(NOPACKAGE)
- ENABLE(*)

Correspondence of procedure options to BIND options

The following table lists the corresponding bind command options for specific CREATE PROCEDURE and ALTER PROCEDURE options. For more information about the bind options, see [BIND and REBIND options for packages, plans, and services \(Db2 Commands\)](#).

Correspondence of procedure options to bind options

CREATE PROCEDURE or ALTER PROCEDURE option	Bind commands option
ACCELERATION WAITFOR DATA <i>nnnn.m</i>	ACCELERATIONWAITFOR DATA(<i>nnnn.m</i>)
ACCELERATOR <i>accelerator-name</i>	ACCELERATOR(<i>accelerator-name</i>)
APPLICATION ENCODING SCHEME ASCII	ENCODING(ASCII)
APPLICATION ENCODING SCHEME EBCDIC	ENCODING(EBCDIC)
APPLICATION ENCODING SCHEME UNICODE	ENCODING(UNICODE)
ARCHIVE SENSITIVE NO	ARCHIVESENSITIVE(NO)
ARCHIVE SENSITIVE YES	ARCHIVESENSITIVE(YES)
BUSINESS_TIME SENSITIVE NO	BUSTIMESENSITIVE(NO)
BUSINESS_TIME SENSITIVE YES	BUSTIMESENSITIVE(YES)
CURRENT DATA NO	CURRENTDATA(NO)
CURRENT DATA YES	CURRENTDATA(YES)
DEFER PREPARE	DEFER(PREPARE)
NODEFER PREPARE	NODEFER(PREPARE)
DEGREE 1	DEGREE(1)
DEGREE ANY	DEGREE(ANY)
DYNAMICRULES RUN	DYNAMICRULES(RUN)
DYNAMICRULES BIND	DYNAMICRULES(BIND)
DYNAMICRULES DEFINEBIND	DYNAMICRULES(DEFINEBIND)
DYNAMICRULES DEFINERUN	DYNAMICRULES(DEFINERUN)
DYNAMICRULES INVOKEBIND	DYNAMICRULES(INVOKEBIND)
DYNAMICRULES INVOKERUN	DYNAMICRULES(INVOKERUN)

CREATE PROCEDURE or ALTER PROCEDURE option	Bind commands option
GET_ACCEL_ARCHIVE NO	GETACCELARCHIVE(NO)
GET_ACCEL_ARCHIVE YES	GETACCELARCHIVE(YES)
ISOLATION LEVEL CS	ISOLATION(CS)
ISOLATION LEVEL RS	ISOLATION(RS)
ISOLATION LEVEL RR	ISOLATION(RR)
ISOLATION LEVEL UR	ISOLATION(UR)
OPTHINT <i>string-constant</i>	OPTHINT(<i>hint-id</i>)
PACKAGE OWNER <i>authorization-name</i>	OWNER(<i>authorization-id</i>)
QUALIFIER <i>schema-name</i>	QUALIFIER(<i>qualifier-name</i>)
QUERY ACCELERATION NONE	QUERYACCELERATION(NONE)
QUERY ACCELERATION ENABLE	QUERYACCELERATION(ENABLE)
QUERY ACCELERATION ENABLE WITH FAILBACK	QUERYACCELERATION(ENABLE WITH FAILBACK)
QUERY ACCELERATION ELIGIBLE	QUERYACCELERATION(ELIGIBLE)
QUERY ACCELERATION ALL	QUERYACCELERATION(ALL)
RELEASE AT COMMIT	RELEASE(COMMIT)
RELEASE AT DEALLOCATE	RELEASE(DEALLOCATE)
REOPT ALWAYS	REOPT(ALWAYS)
REOPT NONE	REOPT(NONE)
REOPT ONCE	REOPT(ONCE)
ROUNDING DEC_ROUND_CEILING	ROUNDING(CEILING)
ROUNDING DEC_ROUND_DOWN	ROUNDING(DOWN)
ROUNDING DEC_ROUNDING_FLOOR	ROUNDING(FLOOR)
ROUNDING DEC_ROUNDING_HALF_DOWN	ROUNDING(HALFDOWN)
ROUNDING DEC_ROUNDING_HALF_EVEN	ROUNDING(HALFEVEN)
ROUNDING DEC_ROUNDING_HALF_UP	ROUNDING(HALFUP)
ROUNDING DEC_ROUNDING_UP	ROUNDING(UP)
SQL PATH <i>path-specification</i>	PATH(<i>path-specification</i>)
SYSTEM_TIME SENSITIVE NO	SYSTIMESENSITIVE(NO)
SYSTEM_TIME SENSITIVE YES	SYSTIMESENSITIVE(YES)
VALIDATE BIND	VALIDATE(BIND)
VALIDATE RUN	VALIDATE(RUN)
WITH EXPLAIN	EXPLAIN(YES)
WITHOUT EXPLAIN	EXPLAIN(NO)
WITH IMMEDIATE WRITE	IMMEDWRITE(YES)

CREATE PROCEDURE or ALTER PROCEDURE option	Bind commands option
WITHOUT IMMEDIATE WRITE	IMMEDWRITE(NO)
WITH KEEPYNAMIC	KEEPYNAMIC(YES)
WITHOUT KEEPYNAMIC	KEEPYNAMIC(NO)

Application compatibility level considerations for procedure objects

The application compatibility level controls the adoption and use of new capabilities and enhancements. When an object is created or altered, two separate application compatibility levels are used: one to process the definition of the object, and the other for processing the SQL statements in the object body:

Object definition	<p>The CURRENT APPLICATION COMPATIBILITY special register value is used to process the object definition, except for statements in the object body</p> <p>This application compatibility level is stored in the SYSENVIRONMENT.APPLCOMPAT column. You can use the environment ID value in the catalog definition of the object to locate the SYSENVIRONMENT row with the matching ENVID value.</p> <p>This application compatibility level can be changed when the object is regenerated.</p>
Statements in the object body	<p>The application compatibility level that is implicitly or explicitly specified with the APPLCOMPAT option of the CREATE or ALTER statement is used to process statements in the object body.</p> <p>This application compatibility level is stored in the SYSPACKAGE.APPLCOMPAT column for the package associated with the object definition.</p>

Considerations for SQL processor programs

SQL processor programs, such as SPUFI, the command line processor, and DSNTEP2, might not correctly parse SQL statements that end with semicolons in the routine body of a CREATE PROCEDURE statement. These processor programs accept multiple SQL statements as input, with each statement separated with a terminator character. Processor programs that use a semicolon as the SQL statement terminator can truncate a CREATE PROCEDURE statement with embedded semicolons and pass only a portion of it to Db2. Therefore, you might need to change the SQL terminator character for these processor programs. For more information, see [Setting the SQL terminator character in a SPUFI input data set \(Db2 Application programming and SQL\)](#), and [SQLTERM in DSNTEP2 and DSNTEP4 sample programs \(Db2 Application programming and SQL\)](#).

Identifier resolution

See Chapter 8, “SQL procedural language (SQL PL),” on page 2207 for information on how names are resolved to columns, variables, or SQL parameters within an SQL routine.

If duplicate names are used for columns, variables, and parameters, qualify the duplicate names by using the table designator for columns, the routine name for parameters, the label name for SQL variables, and the schema name for global variables.

Lines within the SQL procedure definition

When an SQL procedure is created, information is retained on lines in the CREATE statement. Lines are determined by the presence of the new line control character.

In an SQL procedure, a *new line control character* is a special character that is used for a new line. The new line control characters for an SQL procedure include:

- Line feed

- New line
- Carriage return
- Carriage return, followed by a line feed
- Carriage return, followed by a new line

For more information about control characters, see [Tokens](#).

Stored procedures with a parameter that is defined as an array type

A procedure that is defined with a parameter that is an array type, other than an array global variable, can be invoked only from within an SQL PL context, or from a Java application program that uses IBM Data Server Driver for JDBC and SQLJ type 4 connectivity, unless the corresponding argument in the CALL statement is an array global variable. If the corresponding argument in the CALL statement is an array global variable, the procedure can be invoked outside an SQL PL context.

Obfuscated statements

A CREATE PROCEDURE statement for a native SQL procedure can be executed in obfuscated form. In an obfuscated statement, only the procedure name, parameters, and the WRAPPED keyword are readable. The rest of the statement is encoded in such a way that it is not readable but can be decoded by a database server that supports obfuscated statements. The WRAP scalar function produces obfuscated statements. Any debug options that are specified when the function is created from an obfuscated statement are ignored.

Compatibilities

For compatibility with previous versions of Db2, the following clauses can be specified, but they will be ignored and a warning will be issued:

- STAY RESIDENT
- PROGRAM TYPE
- RUN OPTIONS
- NO DBINFO
- COLLID or NOCOLLID
- SECURITY
- PARAMETER STYLE GENERAL WITH NULLS
- STOP AFTER SYSTEM DEFAULT FAILURES
- STOP AFTER *nn* FAILURES
- CONTINUE AFTER FAILURES
- PARAMETER VARCHAR

If the FENCED or EXTERNAL clause is specified, an external SQL procedure will be generated. See [“CREATE PROCEDURE statement \(SQL - external procedure\) \(deprecated\)”](#) on page 1597 for more information.

If WLM ENVIRONMENT is specified without the FOR DEBUG MODE keywords, and error is returned. If WLM ENVIRONMENT is specified for a native SQL procedure, WLM ENVIRONMENT FOR DEBUG MODE must be specified.

Alternative syntax and synonyms

To provide compatibility with previous releases of Db2 or other products in the Db2 family, Db2 supports the following alternative syntax:

- RESULT SET and RESULT SETS as synonyms for DYNAMIC RESULT SETS
- VARIANT as a synonym for NOT DETERMINISTIC
- NOT VARIANT as a synonym for DETERMINISTIC
- NULL CALL as a synonym for CALLED ON NULL

Examples for CREATE PROCEDURE (SQL - native)

Example 1

Create the definition for an SQL procedure. The procedure accepts an employee number and a multiplier for a pay raise as input. The following tasks are performed in the procedure body:

- Calculate the employee's new salary.
- Update the employee table with the new salary value.

```
CREATE PROCEDURE UPDATE_SALARY_1
(IN EMPLOYEE_NUMBER CHAR(10),
 IN RATE DECIMAL(6,2))
LANGUAGE SQL
MODIFIES SQL DATA
UPDATE EMP
SET SALARY = SALARY * RATE
WHERE EMPNO = EMPLOYEE_NUMBER
```

Example 2

Create the definition for the SQL procedure described in example 1, but specify that the procedure has these characteristics:

- The same input always produces the same output.
- SQL work is committed on return to the caller.

```
CREATE PROCEDURE UPDATE_SALARY_1
(IN EMPLOYEE_NUMBER CHAR(10),
 IN RATE DECIMAL(6,2))
LANGUAGE SQL
MODIFIES SQL DATA
DETERMINISTIC
COMMIT ON RETURN YES
UPDATE EMP
SET SALARY = SALARY * RATE
WHERE EMPNO = EMPLOYEE_NUMBER
```

Example 3:

Create the definition for an SQL procedure that uses arrays as IN and OUT parameters. The procedure is named GETWEEKENDS. It accepts an array of DATE values as input, and returns an array that contains only the dates that fall on a Saturday or Sunday. For example, if the input dates are a Saturday, a Friday, and a Sunday, the procedure returns only the dates that fall on Saturday and Sunday.

Suppose that the following user-defined array type has been defined:

```
CREATE TYPE DATEARRAY AS DATE ARRAY[100];
```

After the array type is created, any references to it need to specify the fully qualified user-defined array type name. Otherwise, the schema for the type needs to be in the CURRENT PATH.

Suppose that the SQL procedure is defined like this:

```
CREATE PROCEDURE GETWEEKENDS(IN MYDATES DATEARRAY, OUT WEEKENDS DATEARRAY)
BEGIN
  -- ARRAY INDEX VARIABLES
  DECLARE DATEINDEX, WEEKENDINDEX INT DEFAULT 1;
  -- VARIABLE TO STORE THE ARRAY LENGTH OF MYDATES,
  -- INITIALIZED USING THE CARDINALITY FUNCTION.
  DECLARE DATESCOUNT INT;
  SET DATESCOUNT = CARDINALITY(MYDATES);
  -- FOR EACH DATE IN MYDATES, IF THE DATE IS A SUNDAY OR SATURDAY,
  -- ADD IT TO THE OUTPUT ARRAY NAMED "WEEKENDS"
  WHILE DATEINDEX <= DATESCOUNT DO
    IF DAYOFWEEK(MYDATES[DATEINDEX]) IN (1, 7) THEN
      SET WEEKENDS[WEEKENDINDEX] = MYDATES[DATEINDEX];
      SET WEEKENDINDEX = WEEKENDINDEX + 1;
    END IF;
  END WHILE;
END
```



```
SET DATEINDEX = DATEINDEX + 1;
END WHILE;
END
```

Also suppose that input array MYDATES contains the following content:

```
['2012-04-28', '2012-02-10', '2012-03-18']
```

After the procedure returns, output array WEEKENDS contains the following content:

```
['2012-04-28', '2012-03-18']
```

Example 4

Create the definition for an SQL procedure that uses arrays as OUT parameters. The procedure is named GET_PHONES. It returns an array that contains phone numbers for employee 1775. If more than five phone numbers exist for the employee, an error is returned because the array is defined for only five elements.

Suppose that the following user-defined array type and table have been defined:

```
CREATE TYPE PHONELIST AS DECIMAL(10, 0) ARRAY[5];
CREATE TABLE EMP_PHONES(ID INTEGER, PHONENUMBER DECIMAL(10,0));
```

The SQL procedure is defined like this:

```
CREATE PROCEDURE GET_PHONES(OUT EPHONES PHONELIST)
BEGIN
  SELECT ARRAY_AGG(PHONENUMBER)
  INTO EPHONES
  FROM EMP_PHONES
  WHERE ID = 1775;
END
```

For more examples of SQL procedures, see [Chapter 8, “SQL procedural language \(SQL PL\),” on page 2207](#).

Related concepts

[Routines in Db2 for z/OS: functions and procedures \(Introduction to Db2 for z/OS\)](#)

[Naming conventions](#)

The rules for forming a name depend on the type of the object designated by the name.

Related tasks

[Creating native SQL procedures \(Db2 Application programming and SQL\)](#)

[Migrating an external SQL procedure to a native SQL procedure \(Db2 Application programming and SQL\)](#)

CREATE ROLE statement

The CREATE ROLE statement creates a role at the current server.

Invocation for CREATE ROLE

This statement can be embedded in an application program or issued interactively. It is an executable statement that can be dynamically prepared only if DYNAMICRULES RUN behavior is in effect. For more information, see [“Authorization IDs and dynamic SQL” on page 94](#).

Authorization for CREATE ROLE

The privilege set that is defined below must include at least one of the following authorities:

- SYSADM authority
- SYSCTRL authority
- SECADM

Privilege set: If the statement is embedded in an application program, the privilege set is the set of privileges that are held by the owner of the plan or package.

If the statement is dynamically prepared, the privilege set is the set of privileges that are held by the SQL authorization ID of the process or by the role that is associated with the primary authorization ID, if the statement is run in a trusted context and the `ROLE AS OBJECT OWNER` clause is specified.

Syntax for CREATE ROLE

```
► CREATE ROLE — role-name ◄
```

Description for CREATE ROLE

role-name

Names the role. The name must not identify a role that exists at the current server. The name must not begin with the characters 'SYS' and must not be 'DBADM', 'NONE', 'NULL', 'PUBLIC', or 'SECADM'.

Examples for CREATE ROLE

The following statement creates a role named TELLER.

```
CREATE ROLE TELLER;
```

Related concepts

[Roles in a trusted context \(Managing Security\)](#)

[Managing access through authorization IDs and roles \(Managing Security\)](#)

[Naming conventions](#)

The rules for forming a name depend on the type of the object designated by the name.

CREATE SEQUENCE statement

The `CREATE SEQUENCE` statement creates a sequence at the current server.

Invocation for CREATE SEQUENCE

This statement can be embedded in an application program or issued interactively. It is an executable statement that can be dynamically prepared only if `DYNAMICRULES RUN` behavior is in effect. For more information, see [“Authorization IDs and dynamic SQL”](#) on page 94.

Authorization for CREATE SEQUENCE

The privilege set that is defined below must include at least one of the following:

- The `CREATEIN` privilege on the schema
- `SYSADM` or `SYSCTRL` authority
- System `DBADM`
- Installation `SYSOPR` authority (when the current `SQLID` of the process is set to `SYSINSTL`)

The authorization ID that matches the schema name implicitly has the `CREATEIN` privilege on the schema.

Privilege set: If the statement is embedded in an application program, the privilege set is the privileges that are held by the owner of the plan or package. If the application is bound in a trusted context with the `ROLE AS OBJECT OWNER` clause specified, a role is the owner. Otherwise, an authorization ID is the owner.

If the statement is dynamically prepared, the privilege set is the privileges that are held by the SQL authorization ID of the process unless the process is within a trusted context and the `ROLE AS OBJECT OWNER` clause is specified. In that case, the privileges set is the privileges that are held by the role that is associated with the primary authorization ID of the process.

If the data type of the sequence is a distinct type, the privilege set must include the `USAGE` privilege on the distinct type.

Syntax for CREATE SEQUENCE

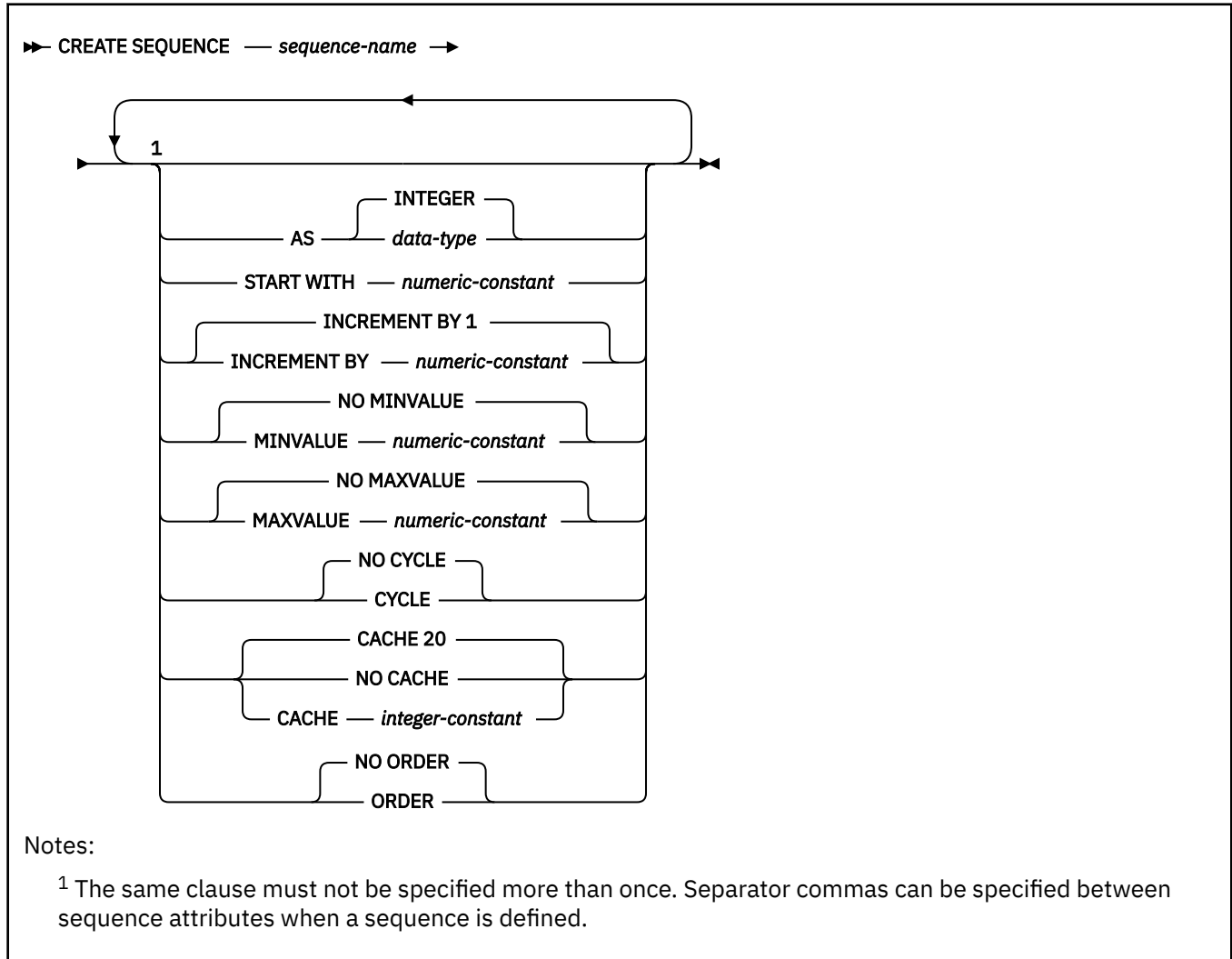

data-type:

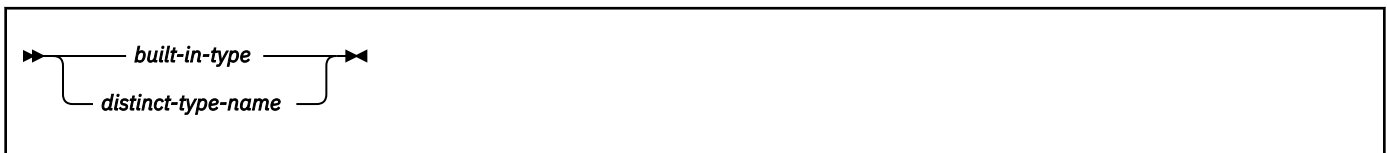

built-in-type:

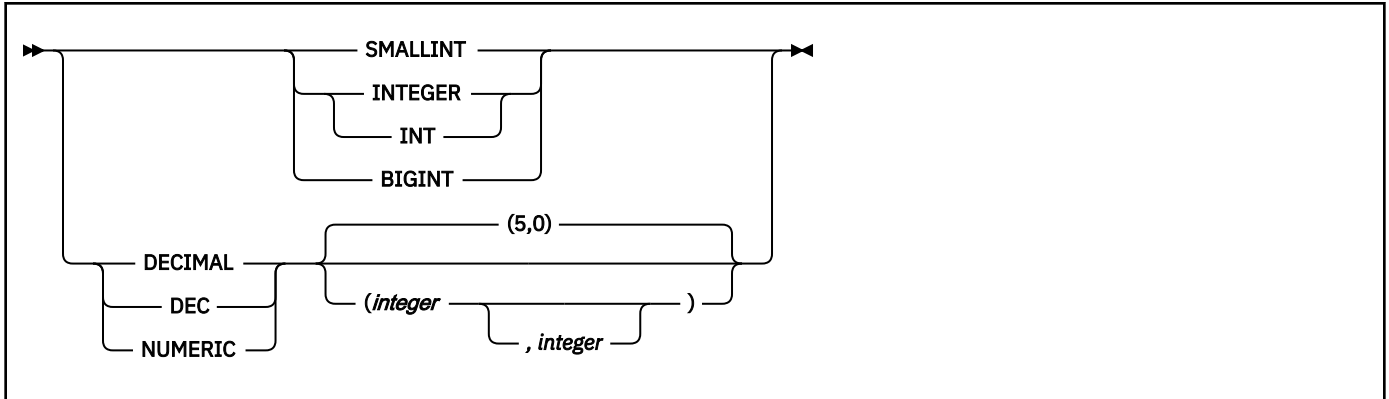

Description for CREATE SEQUENCE

sequence-name

Names the sequence. The name, including the implicit or explicit qualifiers, must not identify an existing sequence at the current server, including the sequence names that are generated by Db2.

The schema name must not begin with 'SYS' unless the schema name is 'SYSADM'.

AS data-type

Specifies the data type to be used for the sequence value. The data type can be any exact numeric data type (SMALLINT, INTEGER, BIGINT, or DECIMAL with a scale of zero), or a user-defined distinct type for which the source type is an exact numeric data type with a scale of zero. The default, when AS is not specified, is INTEGER. If DECIMAL is specified, the default is DECIMAL(5,0).

START WITH numeric-constant

Specifies the first value for the sequence. The value can be any positive or negative value that could be assigned to the a column of the data type that is associated with the sequence without non-zero digits existing to the right of the decimal point.

If the START WITH clause is not explicitly specified with a value, the default is the MINVALUE for ascending sequences and MAXVALUE for descending sequences.

This value is not necessarily the value that a sequence would cycle to after reaching the maximum or minimum value of the sequence. The START WITH clause can be used to start a sequence outside the range that is used for cycles. The range used for cycles is defined by MINVALUE and MAXVALUE.

INCREMENT BY numeric-constant

Specifies the interval between consecutive values of the sequence. The value can be any positive or negative value (including 0) that could be assigned to a column of the data type that is associated with the sequence without any non-zero digits existing to the right of the decimal point. The default is 1.

If INCREMENT BY is positive, the sequence ascends. If INCREMENT BY is negative, the sequence descends. If INCREMENT is 0, the sequence is treated as an ascending sequence.

The absolute value of INCREMENT BY can be greater than the difference between MAXVALUE and MINVALUE.

MINVALUE or NO MINVALUE

Specifies the minimum value at which a descending sequence either cycles or stops generating values or an ascending sequence cycles to after reaching the maximum value. The default is NO MINVALUE.

MINVALUE numeric-constant

Specifies the minimum end of the range of values for the sequence. The last value that is generated for a cycle of a descending sequence will be equal to or greater than this value. MINVALUE is the value to which an ascending sequence cycles to after reaching the maximum value.

The value can be any positive or negative value that could be assigned to the a column of the data type that is associated with the sequence without non-zero digits existing to the right of the decimal point. The value must be less than or equal to the maximum value.

For the effects of defining MINVALUE and MAXVALUE with the same value, see [“Defining a constant sequence” on page 1643](#).

NO MINVALUE

Specifies that the minimum end point of the range of values for the sequence has not been specified explicitly. In such a case, the default value for MINVALUE becomes one of the following:

- For an ascending sequence, the value is the START WITH value or 1 if START WITH is not specified.
- For a descending sequence, the value is the minimum value of the data type that is associated with the sequence.

MAXVALUE or NO MAXVALUE

Specifies the maximum value at which an ascending sequence either cycles or stops generating values or an descending sequence cycles to after reaching the minimum value. The default is NO MAXVALUE.

MAXVALUE *numeric-constant*

Specifies the maximum end of the range of values for the sequence. The last value that is generated for a cycle of an ascending sequence will be less than or equal to this value. MAXVALUE is the value to which a descending sequence cycles to after reaching the minimum value.

The value can be any positive or negative value that could be assigned to the a column of the data type that is associated with the sequence without non-zero digits existing to the right of the decimal point. The value must be greater than or equal to the minimum value.

For the effects of defining MAXVALUE and MINVALUE with the same value, see [“Defining a constant sequence” on page 1643](#).

NO MAXVALUE

Specifies the maximum end point of the range of values for the sequence has not been specified explicitly. In such a case, the default value for MAXVALUE becomes one of the following:

- For an ascending sequence, the value is the maximum value of the data type that is associated with the sequence.
- For a descending sequence, the value is the START WITH value or -1 if START WITH is not specified.

To find the maximum possible value for a given data type, see [Appendix A, “Limits in Db2 for z/OS,” on page 2247](#).

CYCLE or NO CYCLE

Specifies whether or not the sequence should continue to generate values after reaching either its maximum or minimum value. The boundary of the sequence can be reached either with the next value landing exactly on the boundary condition or by overshooting it. The default is NO CYCLE.

CYCLE

Specifies that the sequence continue to generate values after either the maximum or minimum value has been reached. If this option is used, after an ascending sequence reaches its maximum value, it generates its minimum value. After a descending sequence reaches its minimum value, it generates its maximum value. The maximum and minimum values for the sequence defined by the MINVALUE and MAXVALUE options determine the range that is used for cycling.

When CYCLE is in effect, duplicate values can be generated by the sequence. When a sequence is defined with CYCLE, any application conversion tools for converting applications from other vendor platforms to Db2 should also explicitly specify MINVALUE, MAXVALUE, and START WITH values.

NO CYCLE

Specifies that the sequence cannot generate more values once the maximum or minimum value for the sequence has been reached. The NO CYCLE option (the default) can be altered to CYCLE at any time during the life of the sequence.

When the next value is being generated for a sequence if the maximum value (for an ascending sequence) or the minimum value (for a descending sequence) of the logical range of the sequence is exceeded and the NO CYCLE option is in effect, an error occurs.

CACHE or NO CACHE

Specifies whether or not to keep some preallocated values in memory for faster access. This is a performance and tuning option.

CACHE *integer-constant*

Specifies the maximum number of values of the sequence that Db2 can preallocate and keep in memory. Preallocating values in the cache reduces synchronous I/O when values are generated for the sequence. The actual number of values that Db2 caches is always the lesser of the number in effect for the CACHE option and the number of remaining values within the logical range. Thus, the CACHE value is essentially an upper limit for the size of the cache.

The minimum value is 2. The default is CACHE 20.

In a non-data sharing environment, if the system is shut down (either normally or through a system failure), all cached sequence values that have not been used in committed statements are lost (that is, they will never be used). The value specified for the CACHE option is the maximum number of sequence values that could be lost when the system is shut down.

In a data sharing environment, you can use the CACHE and NO ORDER options to allow multiple Db2 members to cache sequence values simultaneously.

NO CACHE

Specifies that values of the sequence are not to be preallocated. This option ensures that there is not a loss of values in the case of a system failure. When NO CACHE is specified, the values of the sequence are not stored in the cache. In this case, every request for a new value for the sequence results in synchronous I/O to the log.

ORDER or NO ORDER

Specifies whether the sequence numbers must be generated in order of request. The default is NO ORDER.

ORDER

Specifies that the sequence numbers are generated in order of request.

In a non-data sharing environment, there is no guarantee that values are assigned in order across the entire server unless NO CACHE is also specified. ORDER applies only to a single-application process.

In a data sharing environment, if ORDER is specified, NO CACHE is implicitly set, even if CACHE *integer-constant* is specified.

NO ORDER

Specifies that the sequence numbers do not need to be generated in order of request.

In a data sharing environment, if the NO ORDER and CACHE *integer-constant* options are in effect, multiple caches can be active simultaneously, and the requests for next value assignments from different Db2 members might not result in the assignment of values in strict numeric order. For example, if members DB2A and DB2B are using the same sequence, and DB2A gets the cache values 1 to 20 and DB2B gets the cache values 21 to 40, the actual order of values assigned would be 1, 21, 2 if DB2A requested the next value first, then DB2B requested, and then DB2A again requested. Therefore, to guarantee that sequence numbers are generated in strict numeric order among multiple Db2 members using the same sequence concurrently, specify the ORDER option.

Notes for CREATE SEQUENCE

Owner privileges

The owner is authorized to change (ALTER privilege) or use (USAGE privilege) the sequence and grant others these privileges. See “GRANT statement (sequence privileges)” on page 1979. For more information about ownership of the object see [“Authorization, privileges, permissions, masks, and object ownership” on page 90](#).

Relationship of MINVALUE and MAXVALUE

MINVALUE must not be greater than MAXVALUE. Although MINVALUE is typically less than MAXVALUE, MINVALUE can equal MAXVALUE. If START WITH were the same value as MINVALUE and MAXVALUE, the sequence would be constant. The request for the next value in a constant sequence appears to have no effect because all of the values that are generated by the sequence are in fact the same value.

Defining sequences that cycle

When you define a sequence, you can choose to have it cycle automatically or not when the maximum or minimum value for the sequence has been reached.

- Implicitly or explicitly defining a sequence with NO CYCLE causes the sequence to not cycle automatically after the boundary is reached. However, you can use the ALTER SEQUENCE statement to cycle the sequence manually. ALTER SEQUENCE allows you to restart or extend the sequence, which causes sequence values to continue to be generated.
- Explicitly defining a sequence with CYCLE causes the sequence to cycle automatically after the boundary is reached. Sequence values continue to be generated after the sequence cycles.

When a sequence is defined to cycle automatically, the maximum or minimum value that is generated for a sequence might not be the actual MAXVALUE or MINVALUE value that is specified if the increment is a value other than 1 or -1. For example, the sequence defined with START WITH=1, INCREMENT=2, MAXVALUE=10 will generate a maximum value of 9, and will not generate the value 10.

When a sequence is defined with CYCLE, any application conversion tools (for converting applications from other vendor platforms to Db2) should also explicitly specify MINVALUE, MAXVALUE, and START WITH.

Defining a constant sequence

You can define a sequence such that it always returns the same (or a constant) value. To create a constant sequence, use either of these techniques when defining the sequence:

- Specify an INCREMENT value of zero and a START WITH value that does not exceed MAXVALUE. Use this option in most cases, and especially if the constant sequence is used often, such as for transaction workloads.
- Specify the same value for START WITH, MINVALUE, and MAXVALUE, and specify CYCLE. This option requires more log write activity and can result in longer wait times, especially if the sequence is used often.

A constant sequence can be used as a numeric global variable. You can use ALTER SEQUENCE to adjust the values that are generated for a constant sequence.

Consumed values of a sequence

After Db2 generates a value for a sequence, that value can be said to be "consumed" regardless of whether or not that value is used by the application or not. The value is not reused within the current cycle. A consumed value might not be used when the statement that caused the value to be generated fails for some reason or is rolled back after the value was generated. Generated but unused values can constitute gaps in a sequence.

Gaps in a sequence

Consecutive values in a sequence differ by the constant INCREMENT BY value specified for the sequence. However, gaps can occur in the values that are assigned to a sequence object by Db2.

The following situations are some examples of how gaps can be introduced in the sequence values:

- A transaction has advanced the sequence and then rolls back.
- The SQL statement leading to the generation of the next value fails after the value was generated.
- The NEXT VALUE expression is used in the SELECT statement of a cursor in a DRDA environment where the client uses block-fetch and not all retrieved rows are fetched by the application.
- The sequence is altered and then the alteration is rolled back.

- The sequence (or an identity column table) is dropped and then the drop is rolled back.
- The SYSIBM.SYSSEQ table space is stopped or closed for any reason (including when DSMAX is reached)
- The Db2 subsystem is stopped or goes down

Values of such gaps are not available for the current cycle, unless the sequence is altered and restarted in a specific way to make them available.

A sequence is incremented independently of a transaction. Thus, a given transaction increments the sequence two times might see a gap in the two numbers that it receives if other transactions concurrently increment the same sequence. Most applications can tolerate these instances as these are not really gaps.

Duplicate sequence values

It is possible the duplicate values can be generated for a sequence. Duplicate values are most likely to occur when a sequence is defined with the CYCLE option, is defined as a constant sequence, or is altered. For example, the following situations could cause duplicate sequence values:

- A sequence is defined with the attributes START WITH=2, INCREMENT BY 2, MINVALUE=2, MAXVALUE=10, and CYCLE.
- The ALTER SEQUENCE statement is used to restart the sequence with a value that has already been generated.
- The ALTER SEQUENCE statement is used to reverse the ascending direction of a sequence by changing the INCREMENT BY value from a positive to a negative.

Using sequences

A sequence can be referenced using a *sequence-reference*. A sequence reference can appear in most places that an expression can appear. A sequence reference can specify whether the value to be returned is a newly generated value or the previously generated value. A NEXT VALUE sequence expression is used to generate a new value. A PREVIOUS VALUE sequence expression is used to obtain the last assigned value of a sequence. For more information, see [“Sequence reference” on page 292](#).

Alternative syntax and synonyms

To provide compatibility with previous releases of Db2 or other products in the Db2 family, Db2 supports the following keywords:

- NOMINVALUE (single key word) as a synonym for NO MINVALUE
- NOMAXVALUE (single key word) as a synonym for NO MAXVALUE
- NOCYCLE (single key word) as a synonym for NO CYCLE
- NOCACHE (single key word) as a synonym for NO CACHE
- NOORDER (single key word) as a synonym for NO ORDER

Examples for CREATE SEQUENCE

Example 1

Create a sequence names "org_seq" that starts at 1 increments by 1, does not cycle, and caches 24 values at a time:

```
CREATE SEQUENCE ORDER_SEQ
  START WITH 1
  INCREMENT BY 1
  NO MAXVALUE
  NO CYCLE
  CACHE 24;
```

INCREMENT 1, NO MAXVALUE, and NO CYCLE are defaults and do not need to be specified.

Example 2

The following example shows how to create and use a sequence named "order_seq" in a table named "orders":

```
CREATE SEQUENCE ORDER_SEQ
  START WITH 1
  INCREMENT BY 1
  NO MAXVALUE
  NO CYCLE
  CACHE 20;
INSERT INTO ORDERS (ORDERNO, CUSTNO)
  VALUES (NEXT VALUE FOR ORDER_SEQ, 123456);
```

or to update the orders:

```
UPDATE ORDERS
  SET ORDERNO = NEXT VALUE FOR ORDER_SEQ
  WHERE CUSTNO = 123456;
```

Example 3

The following example shows how to use the same sequence number as a unique key value in two separate tables by referencing the sequence number with a NEXT VALUE expression for the first row to generate the sequence value and with a PREVIOUS VALUE expression for the other rows to refer to the sequence value most recently generated.

```
INSERT INTO ORDERS (ORDERNO, CUSTNO)
  VALUES (NEXT VALUE FOR ORDER_SEQ, 123456);
INSERT INTO LINE_ITEMS (ORDERNO, PARTNO, QUANTITY)
  VALUES (PREVIOUS VALUE FOR ORDER_SEQ, 987654, 100);
```

If NEXT VALUE is invoked in the same statement as the PREVIOUS VALUE, then regardless of their order in the statement, PREVIOUS VALUE returns the previous (unincremented) value and NEXT VALUE returns the next value.

Related concepts

[Sequences \(Introduction to Db2 for z/OS\)](#)

[Sequence objects \(Db2 Application programming and SQL\)](#)

[Naming conventions](#)

The rules for forming a name depend on the type of the object designated by the name.

CREATE STOGROUP statement

The CREATE STOGROUP statement creates a storage group at the current server. Storage from the identified volumes can later be allocated for table spaces and index spaces.

Invocation for CREATE STOGROUP

This statement can be embedded in an application program or issued interactively. It is an executable statement that can be dynamically prepared only if DYNAMICRULES RUN behavior is in effect. For more information, see [“Authorization IDs and dynamic SQL” on page 94](#).

Authorization for CREATE STOGROUP

The privilege set that is defined below must include at least one of the following:

- The CREATESG privilege
- SYSADM or SYSCTRL authority
- Installation SYSOPR authority (when the current SQLID of the process is set to SYSINSTL)

Privilege set: If the statement is embedded in an application program, the privilege set is the privileges that are held by the owner of the plan or package. If the application is bound in a trusted context with the ROLE AS OBJECT OWNER clause specified, a role is the owner. Otherwise, an authorization ID is the owner.

If the statement is dynamically prepared, the privilege set is the privileges that are held by the SQL authorization ID of the process unless the process is within a trusted context and the `ROLE AS OBJECT OWNER` clause is specified. In that case, the privileges set is the privileges that are held by the role that is associated with the primary authorization ID of the process.

Syntax for CREATE STOGROUP

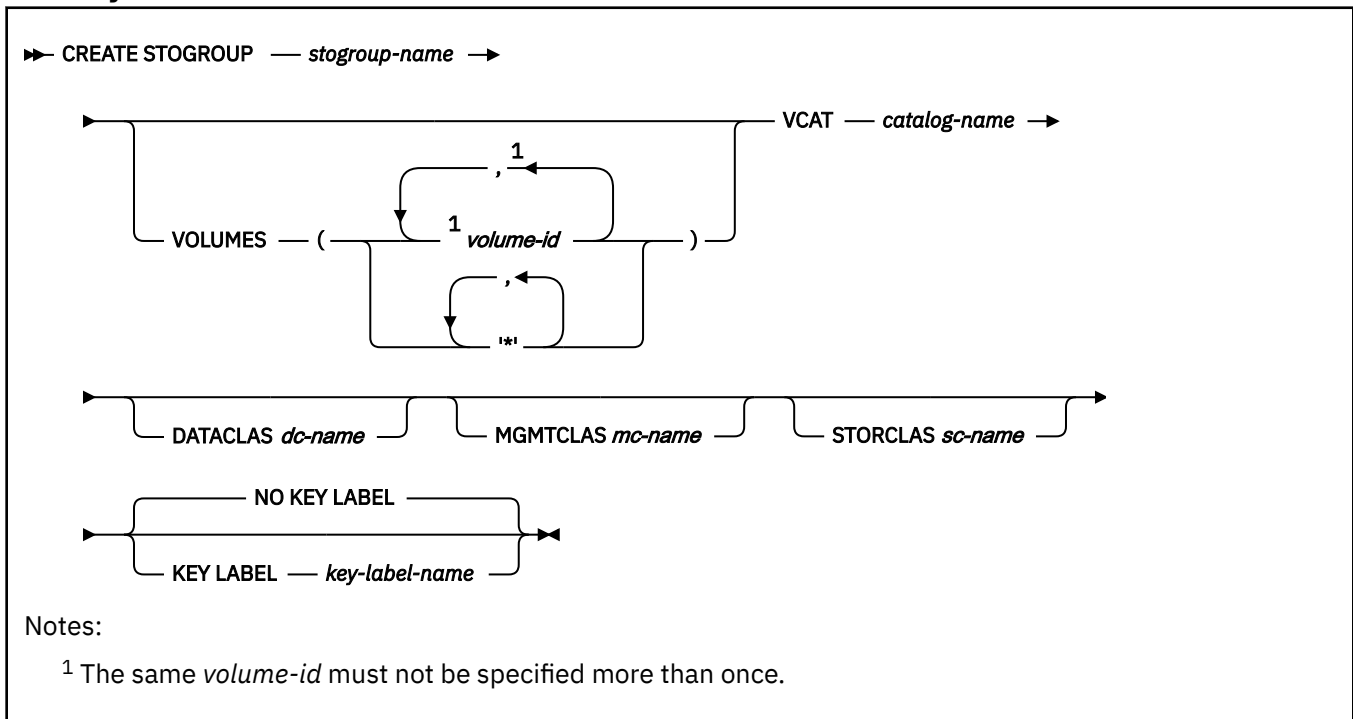

Description for CREATE STOGROUP

stogroup-name

Names the storage group. The name must not identify a storage group that exists at the current server.

VOLUMES(*volume-id*,...) or VOLUMES('*',...)

Defines the volumes of the storage group. Each *volume-id* is a volume serial number of a storage volume. The volume serial number can have a maximum of six characters and is specified as an identifier or a string constant.

If the data set that is associated with the storage group is not managed by Storage Management Subsystem (SMS), VOLUMES must be specified. Asterisks are recognized only by SMS. SMS usage is recommended, rather than using Db2 to allocate data to specific volumes. Having Db2 select the volume requires non-SMS usage or assigning an SMS Storage Class with guaranteed space. However, because guaranteed space reduces the benefits of SMS allocation, it is not recommended. If one or more of the DATACLAS, MGMTCLAS, or STORCLAS clauses are specified, VOLUMES can be omitted. If the VOLUMES clause is omitted, the volume selection is controlled by SMS.

If you do choose to use specific volume assignments, additional manual space management must be performed. Free space must be managed for each individual volume to prevent failures during the initial allocation and extension. This process generally requires more time for space management and results in more space shortages. Guaranteed space should be used only where the space needs are relatively small and do not change.

VCAT *catalog-name*

Identifies the integrated catalog facility catalog for the storage group. The designated catalog is the one in which entries are placed for the data sets created by Db2 with the aid of the storage group, for associated table or index spaces or for their partitions. For each such space or partition, association

is made through a USING clause in a CREATE TABLESPACE, CREATE INDEX, ALTER TABLESPACE, or ALTER INDEX statement. For more on the association, see the descriptions of those statements.

The data sets are VSAM linear data sets cataloged in the integrated catalog facility catalog that *catalog-name* identifies. For more information about *catalog-name* values, see [“Naming conventions in SQL”](#) on page 79.

More than one Db2 subsystem can share the integrated catalog facility catalogs with the current server. To avoid the chance of those subsystems attempting to assign the same name to different data sets, specify a *catalog-name* value that is not used by the other Db2 subsystems.

DATACLAS *dc-name*

Identifies the name of the SMS data class to associate with the Db2 storage group. The SMS data class name must be from 1-8 characters in length. The SMS storage administrator defines the data class that can be used. DATACLAS must not be specified more than one time.

MGMTCLAS *mc-name*

Identifies the name of the SMS management class to associate with the Db2 storage group. The SMS management class name must be from 1-8 characters in length. The SMS storage administrator defines the management class that can be used. MGMTCLAS must not be specified more than one time.

STORCLAS *sc-name*

Identifies the name of the SMS storage class to associate with the Db2 storage group. The SMS storage class name must be from 1-8 characters in length. The SMS storage administrator defines the storage class that can be used. STORCLAS must not be specified more than one time.

FL 502 KEY LABEL *key-label-name* or NO KEY LABEL

Specifies whether a key label is specified at the storage group level for encryption.

KEY LABEL *key-label-name*

Specifies the key label that is used to encrypt any data set allocated for the table spaces and index spaces using the storage group.

The key label must be defined in ICSF. The Db2 address space RACF user ID or group must be permitted access to the key label in RACF.

The key label can be overridden when the data set is allocated. For details about the order of precedence, see Notes.

NO KEY LABEL

Indicates that there is no key label specified at the storage group level for encryption.

Notes for CREATE STOGROUP

Device types

When the storage group is used at run time, an error can occur if the volumes in the storage group are of different device types, or if a volume is not available to z/OS for dynamic allocation of data sets.

When a storage group is used to extend a data set, all volumes in the storage group must be of the same device type as the volumes used when the data set was defined. Otherwise, an extend failure occurs if an attempt is made to extend the data set.

Number of volumes

There is no specific limit on the number of volumes that can be defined for a storage group. However, the maximum number of volumes that can be managed for a storage group is 133.

z/OS imposes a limit on the number of volumes that can be allocated per data set (currently, 59 volumes). For the latest information on that restriction, see *z/OS DFSMS Access Method Services for Catalogs*.

Storage group owner

If the statement is embedded in an application program, the owner of the plan or package is the owner of the storage group. If the statement is dynamically prepared, the SQL authorization ID of the

process is the owner of the storage group. The owner has the privilege of altering and dropping the storage group.

Specifying volume IDs

A new storage group must have either specific volume IDs or non-specific volume IDs. You cannot create a storage group that contains a mixture of specific and non-specific volume IDs.

Verifying the existence of volumes and classes

When processing the VOLUMES, DATACLAS, MGMTCLAS, or STORCLAS clauses, Db2 does not check the existence of the volumes or classes or determine the types of devices that are identified or if SMS is active. Later, when the storage group allocates data sets, the list of volumes is passed to Data Facilities (DFSMSdfp) in the physical order of the rows in the SYSIBM.SYSVOLUMES catalog table. For more information, see [Implementing Db2 storage groups \(Db2 Administration Guide\)](#).

Key label requirement

To use a key label for encryption, the VSAM data sets for the page sets need to be associated with an SMS Data Class that has extended format capability (EF enabled).

Determining a key label for base table space and associated objects

When a key label is specified at the table level, Db2 provides the key label to DFSMS to encrypt all the table spaces and index spaces associated with the table. This includes base table space, auxiliary table spaces, XML table spaces, index spaces, and clone table space, regardless of whether the base table space or associated objects are explicitly or implicitly created. Db2 does not enforce any key label relationship between the base table and an associated history or archive table. The key label for the archive and the history tables has to be set independent of the base table. If there is no key label specified at the table level, Db2 will provide the key label to DFSMS specified for the storage group.

When Db2 calls DFSMS to allocate the dataset for table space or index space, DFSMS uses its order of precedence to determine the key label and can override the key label specified by Db2.

DFSMS order of precedence:

- RACF data set profile
- JCL, dynamic allocation, TSO ALLOCATE
- SMS data class construct

If the security administrator has specified a key label for the RACF data set profile, that key label takes precedence over the Db2 provided key label. The REPORT utility can be run to determine the key label used for encryption.

Examples for CREATE STOGROUP

Example 1

Create storage group, DSN8G120, of volumes ABC005 and DEF008. DSNCAT is the integrated catalog facility catalog name.

```
CREATE STOGROUP DSN8G120
  VOLUMES (ABC005,DEF008)
  VCAT DSNCAT;
```

Example 2

Create storage group DSNCG100 with key label, STG01KLABEL.

```
CREATE STOGROUP DSNCG100
  VOLUMES (ABC001,DEF003) VCAT DSNCAT
  KEY LABEL STG01KLABEL;
```

Related concepts

[Db2 storage groups \(Introduction to Db2 for z/OS\)](#)

[Naming conventions](#)

The rules for forming a name depend on the type of the object designated by the name.

Related tasks

[Creating Db2 storage groups \(Db2 Administration Guide\)](#)

CREATE SYNONYM statement (unsupported)

The CREATE SYNONYM statement is unsupported in application compatibility level V12R1M504 and higher. Use CREATE ALIAS statements instead.

Unsupported function: FL 504 Beginning in Db2 12, packages bound with APPLCOMPAT(V12R1M504) or higher cannot issue CREATE SYNONYM statements. Although there are some differences, you can use aliases instead. Unlike synonyms, aliases behave the same for all Db2 family products. For more information about aliases, see [Aliases \(Introduction to Db2 for z/OS\)](#) and [“CREATE ALIAS statement”](#) on page 1415. Existing synonyms remain supported, but support might be removed in the future.

Invocation for CREATE SYNONYM

This statement can be embedded in an application program or issued interactively. It is an executable statement that can be dynamically prepared only if DYNAMICRULES RUN behavior is in effect. For more information, see [“Authorization IDs and dynamic SQL”](#) on page 94.

Authorization for CREATE SYNONYM

None required.

Syntax for CREATE SYNONYM

```
►► CREATE SYNONYM — synonym — FOR — authorization-name . — table-name — view-name ►►
```

Description for CREATE SYNONYM

synonym

Names the synonym. The name must not identify a synonym, table, view, or alias that exists at the current server and that is owned by the owner of the synonym that is being created and must not identify a table that exists in the SYSIBM.SYSPENDINGOBJECTS catalog table. The unqualified name must not be the same as an existing synonym.

FOR *authorization-name.table-name* or *authorization-name.view-name*

Identifies the object to which the synonym applies. The name must consist of two parts and must identify a table, view, or alias that exists at the current server. If a table is identified, it must not be an auxiliary table or a declared temporary table. If an alias is identified, it must be an alias for a table or view at the current server and the synonym is defined for that table or view. The name must not identify a table that was implicitly created for an XML column, or an accelerator-only table.

Notes for CREATE SYNONYM

Owner privileges: There are no specific privileges on a synonym.

The owner of the synonym is determined as follows:

- If the CURRENT SCHEMA special register contains a value that is not the same as the CURRENT SQLID special register, the owner of the synonym is the value of the CURRENT SCHEMA special register.
- Otherwise, the owner of the schema is the value of the CURRENT SQLID special register.

For more information about ownership of an object, see [“Authorization, privileges, permissions, masks, and object ownership”](#) on page 90.

If an alias is used to denote the table or view, the name of that table or view, not the alias, is recorded in the catalog as the definition of the synonym. That severs the connection between the synonym and alias, and even if the alias is dropped and redefined, the synonym is still in effect and names the original table or view.

Example for CREATE SYNONYM

Define DEPT as a synonym for the table DSN8C10.DEPT.

```
CREATE SYNONYM DEPT
FOR DSN8C10.DEPT;
```

CREATE TABLE statement

The CREATE TABLE statement defines a table. The definition must include its name and the names and attributes of its columns. The definition can include other attributes of the table, such as its primary key and its table space.

Invocation for CREATE TABLE

This statement can be embedded in an application program or issued interactively. It is an executable statement that can be dynamically prepared only if DYNAMICRULES RUN behavior is in effect. For more information, see [“Authorization IDs and dynamic SQL” on page 94](#).

Authorization for CREATE TABLE

The privilege set that is defined below must include at least one of the following:

- The CREATETAB privilege for the database explicitly specified by the IN clause.
If the IN clause is not specified, the CREATETAB privilege on database DSNDB04 is required.
- DBADM, DBCTRL, or DBMAINT authority for the database explicitly specified by the IN clause. If the IN clause is not specified, DBADM, DBCTRL, or DBMAINT authority for database DSNDB04 is required.
- SYSADM or SYSCTRL authority
- System DBADM
- Installation SYSOPR authority (when the current SQLID of the process is set to SYSINSTL)

If the table space is created implicitly, the privilege set that is defined below must include at least one of the following:

- The CREATETS privilege for the database explicitly specified by the IN clause.
If the IN clause is not specified, the CREATETS privilege on database DSNDB04 is required.
- DBADM, DBCTRL, or DBMAINT authority for the database explicitly specified by the IN clause. If the IN clause is not specified, DBADM, DBCTRL, or DBMAINT authority for database DSNDB04 is required.
- SYSADM or SYSCTRL authority
- Installation SYSOPR authority (when the current SQLID of the process is set to SYSINSTL)

The privilege set must also have the USE privilege for the following objects:

- For the table space if one is specified in the IN clause
- For the default buffer pool and default storage group of the database if a database is specified in the IN clause

If you specify a table space name, you must also have the SYSADM or SYSCTRL authority or the DBADM authority for the database.

For tables that are created in an implicit database, the database authority must be held on DSNDB04.

Additional privileges might be required in the following conditions:

- The clause `IN`, `LIKE` or `FOREIGN KEY` is specified.
- The data type of a column is a distinct type.
- The table space is implicitly created.
- A *fullselect* is specified.
- A column is defined as a security label column.

Privilege set: See the description of the appropriate clauses for details about these privileges.

If the statement is embedded in an application program, the privilege set is the privileges that are held by the owner of the package.

If the application is bound in a trusted context with the `ROLE AS OBJECT OWNER` clause specified:

- A role is the owner of the table that is being created
- The privilege set is the set of privileges that are held by that role
- The schema qualifier (implicit or explicit) must be the same as the role, unless the role has the `CREATEIN` privilege on the schema, or `SYSADM`, `SYSCTRL`, or system `DBADM` authority

Otherwise, an authorization ID is the owner of the package, and the following rules apply:

- If the privilege set lacks the `CREATEIN` privilege on the schema, `SYSADM` authority, `SYSCTRL` authority, and System `DBADM` authority, the schema qualifier (implicit or explicit) must be the same as the authorization ID of the owner of the package.
- If the privilege set lacks `SYSADM` authority, `SYSCTRL` authority, and System `DBADM` authority, and the table is explicitly qualified, the authorization ID that is the same as the schema name must have all the necessary privileges to create the table, and that authorization ID is the owner of the table. Otherwise, the authorization ID of the owner of the package must have all the necessary privileges to create the table, and that authorization ID is the owner of the table.
- If the privilege set includes `SYSADM` authority, `SYSCTRL` authority, or system `DBADM` authority, the schema qualifier (implicit or explicit) can be any schema name. However, if the table is explicitly qualified, the authorization ID that is the same as the schema name is the owner of the table. Otherwise, the authorization ID of the owner of the package is the owner of the table.
- If the privilege set includes `DBADM` authority and `DBCTRL` authority for the database, the schema qualifier (implicit or explicit) can be any schema name. However, if the table is explicitly qualified, the authorization ID that is the same as the schema name is the owner of the table. Otherwise, the authorization ID of the owner of the package is the owner of the table.

If the statement is dynamically prepared, the privilege set is the privileges that are held by the SQL authorization ID of the process unless the process is within a trusted context and the `ROLE AS OBJECT OWNER` clause is in effect. When `ROLE AS OBJECT OWNER` is in effect, the privileges set is the privileges that are held by the role that is associated with the primary authorization ID of the process, and the owner of the table is that role. The schema qualifier (implicit or explicit) must be the same as that role, unless the role has `CREATEIN` privilege on the schema, or `SYSADM` authority, `SYSCTRL` authority, or System `DBADM` authority.

For the case where the SQL authorization ID of the process holds the privileges, the following rules apply:

- If the privilege set lacks `CREATEIN` privilege on the schema, `SYSADM` authority, `SYSCTRL` authority, and System `DBADM` authority, the schema qualifier must be the same as one of the authorization IDs of the process.
- If the privilege set lacks `SYSADM` authority, `SYSCTRL` authority, and System `DBADM` authority, and the table is explicitly qualified, then the authorization ID that is the same as the schema name must have all the necessary privileges to create the table, and that authorization ID is the owner of the table. Otherwise, the SQL authorization ID of the process must include all privileges that are needed to create the table, and that authorization ID is the owner of the table.
- If the privilege set includes `SYSADM` authority, `SYSCTRL` authority, or System `DBADM` authority, the schema qualifier can be any schema name. However, if the table is explicitly qualified, then the

authorization ID that is the same as the schema name is the owner of the table. Otherwise, the SQL authorization ID of the process is the owner of the table.

Syntax for CREATE TABLE

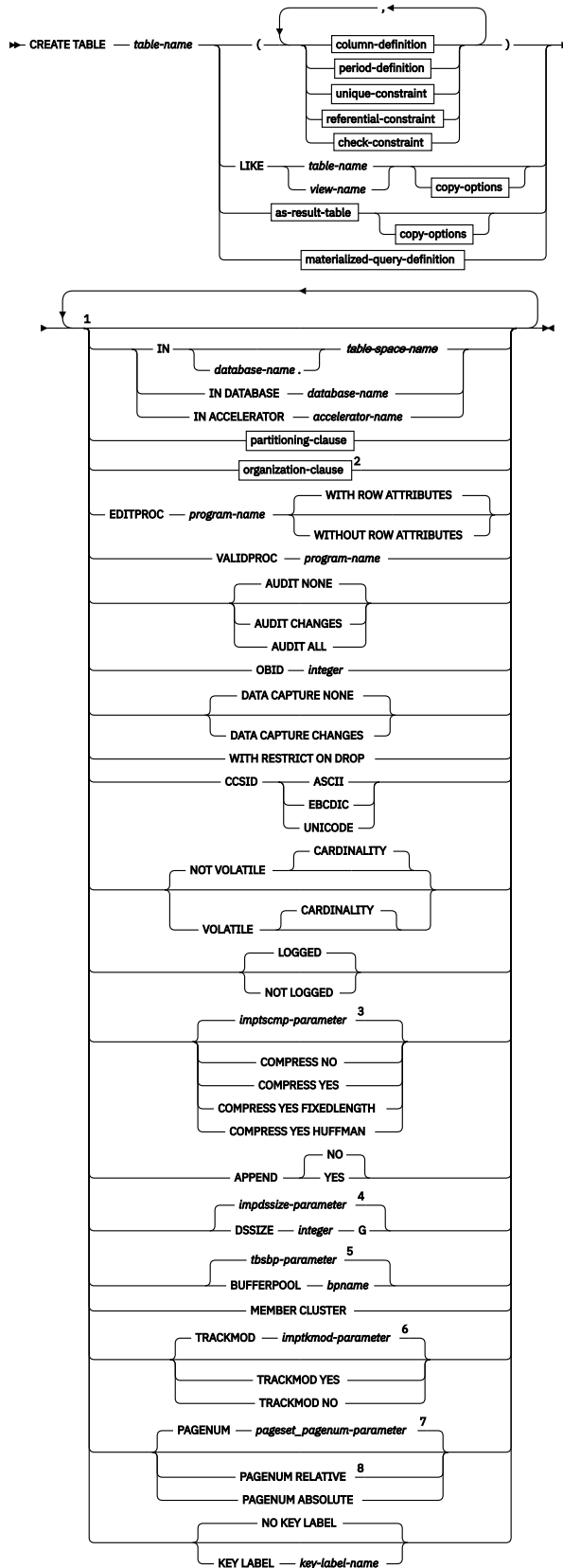

Notes:

¹ The same clause must not be specified more than once.

² FL 504 Hash-organized tables are deprecated. Beginning in Db2 12, packages bound with APPLCOMPAT(V12R1M504) or higher cannot create hash-organized tables or alter existing tables to use hash-organization. Existing hash organized tables remain supported, but they are likely to be unsupported in the future.

³ The IMPTSCMP subsystem parameter specifies the default value. See [USE DATA COMPRESSION field \(IMPTSCMP subsystem parameter\)](#) (Db2 Installation and Migration).

⁴ The IMPDSSIZE subsystem parameter specifies the default value. See [IMPDSSIZE in macro DSN6SYSP](#) (Db2 Installation and Migration).

⁵ The TBSBPOOL, TSBP8K, TSBP16K, or TSBP32K subsystem parameter determines the default value. See [DSNTIP2: Buffer pool sizes panel 2](#) (Db2 Installation and Migration).

⁶ The IMPTKMOD subsystem parameter specifies the default value. See [IMPTKMOD in macro DSN6SYSP](#) (Db2 Installation and Migration).

⁷ See [PAGE SET PAGE NUMBERING field \(PAGESET_PAGENUM subsystem parameter\)](#) (Db2 Installation and Migration).

⁸ PAGENUM RELATIVE is allowed only if a partitioning clause is specified.

column-definition:

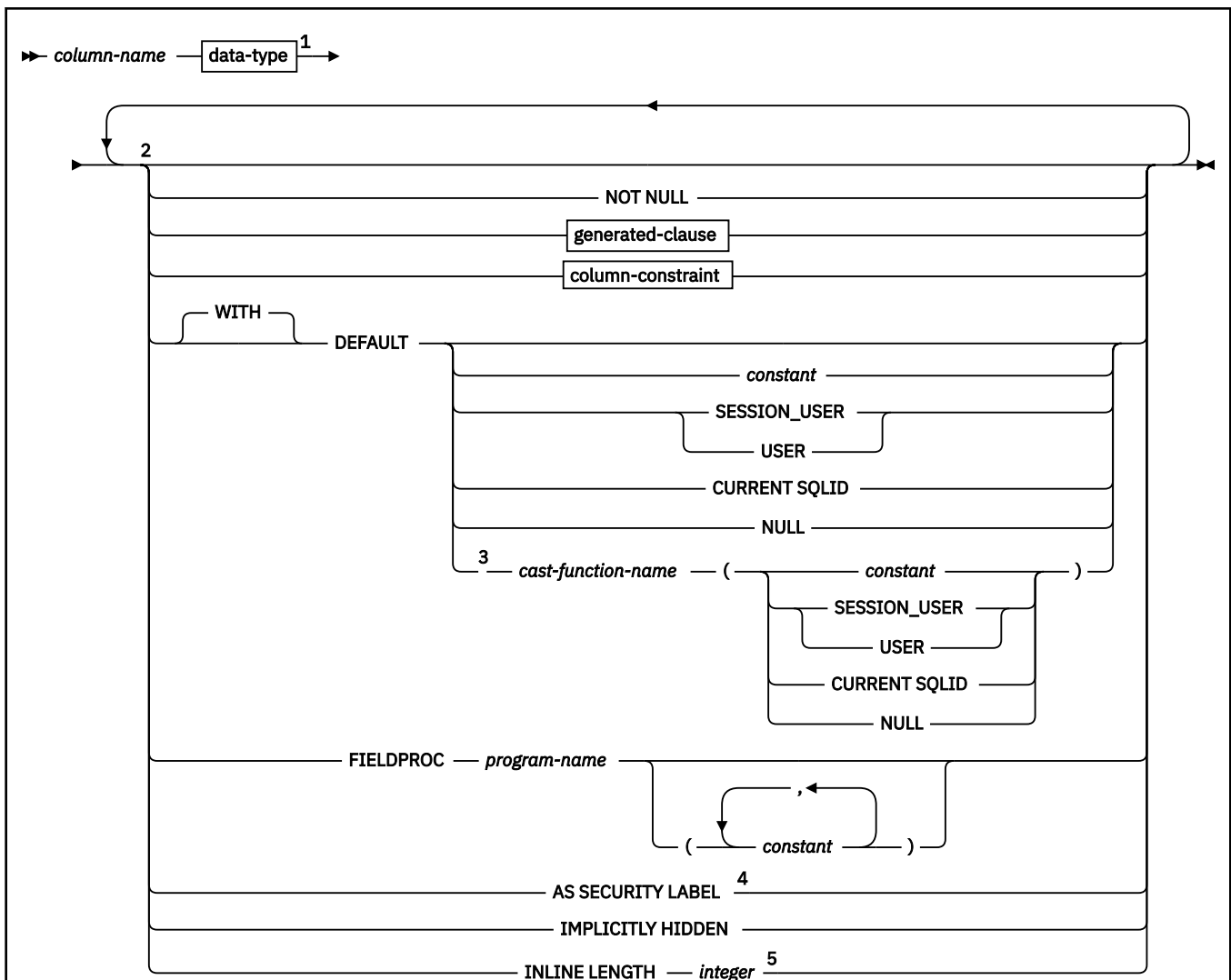

Notes:

¹ Data type is optional if *as-row-change-timestamp-clause* is specified

² The same clause must not be specified more than one time.

- ³ The *cast-function-name* form of the DEFAULT value can only be used with a column that is defined as a distinct type.
- ⁴ AS SECURITY LABEL can be specified only for a CHAR(8) data type and requires that the NOT NULL and WITH DEFAULT clauses be specified.
- ⁵ INLINE LENGTH only applies to a column with a LOB data type or a distinct type that is based on a LOB data type.

data-type:

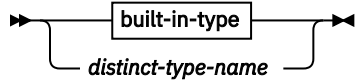

built-in-type:

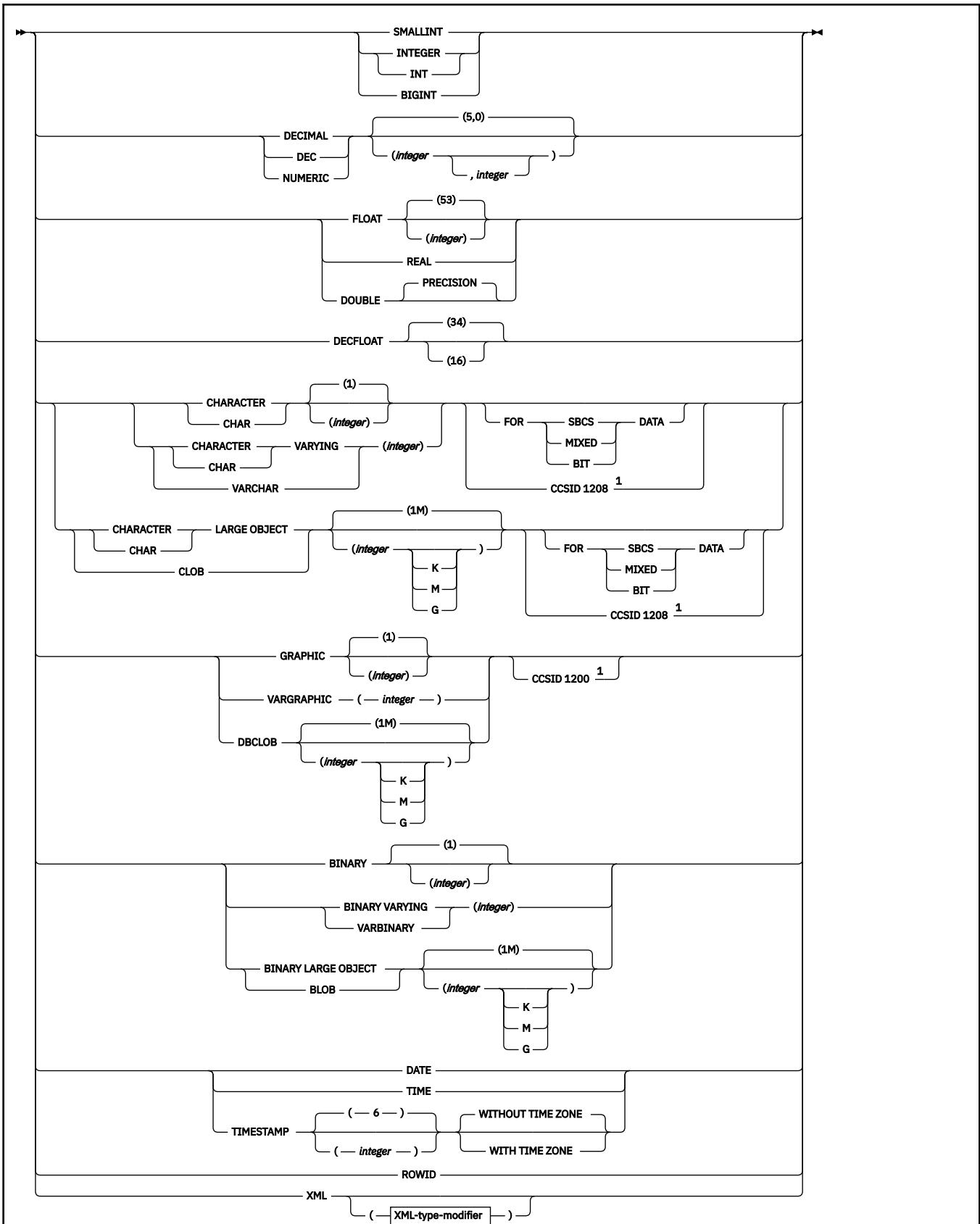

Notes:

¹ The CCSID clause must only be specified for a character string or graphic string column in an EBCDIC table. The CCSID clause must not be specified with *non-deterministic-expression*.

XML-type-modifier:

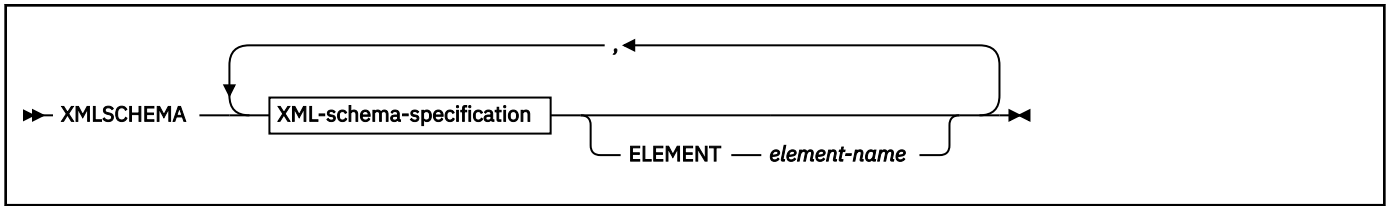

XML-schema-specification:

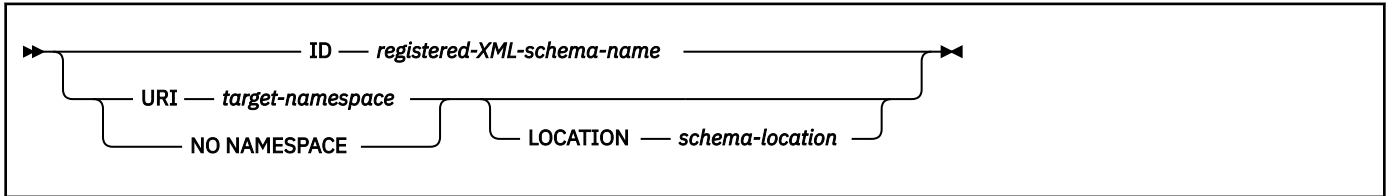

generated-clause:

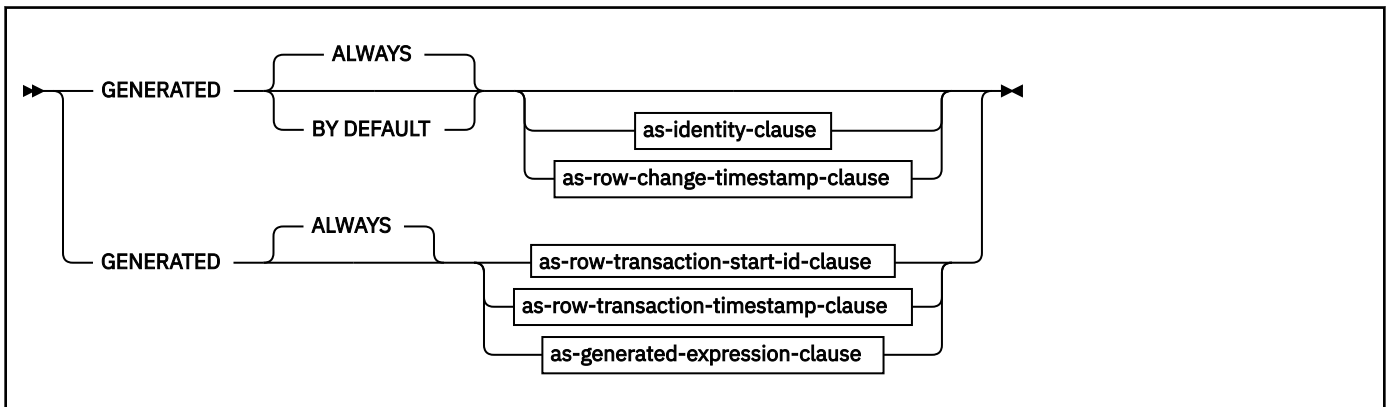

as-identity-clause:

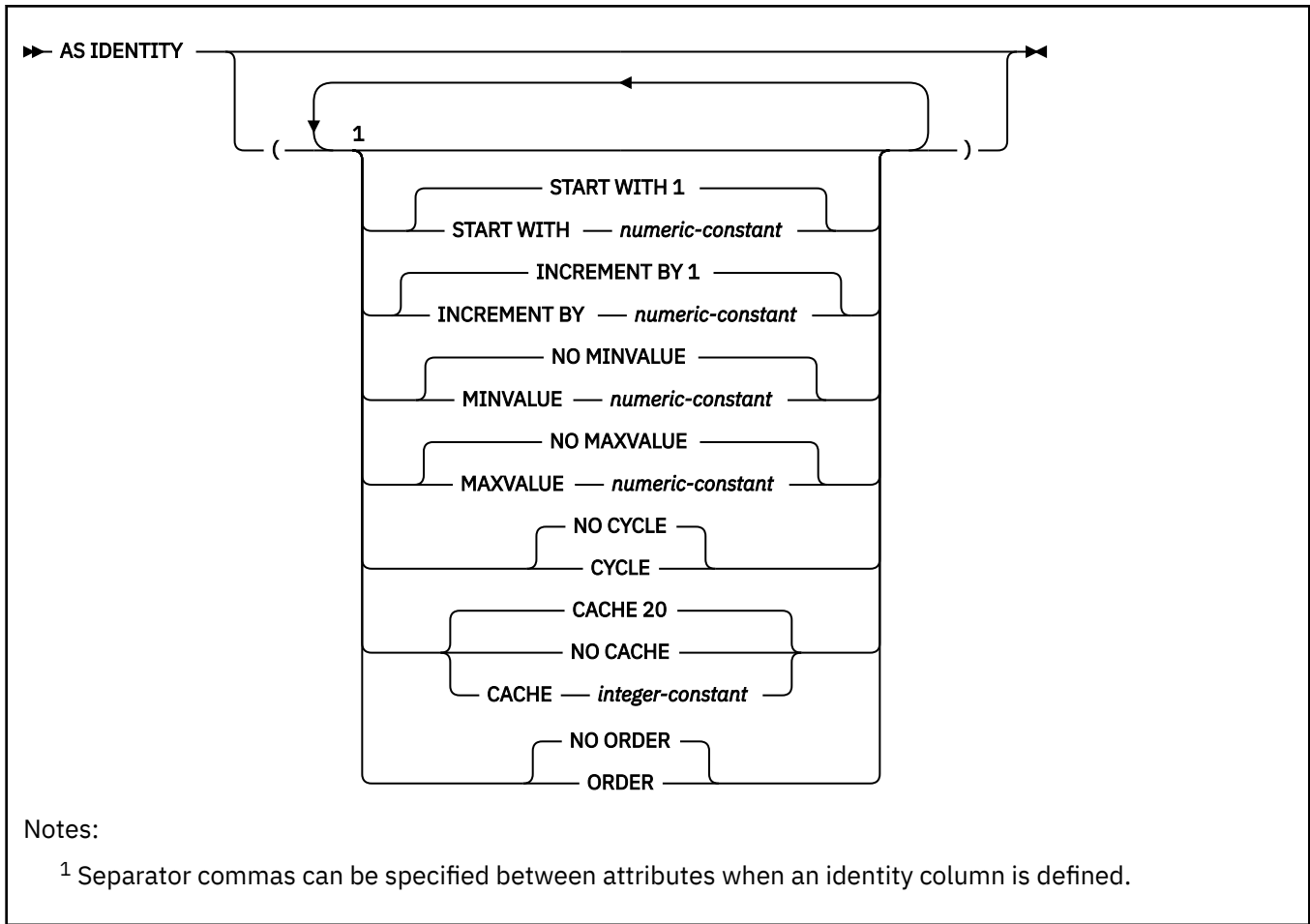

as-row-change-timestamp-clause:

FOR EACH ROW ON UPDATE AS ROW CHANGE TIMESTAMP

as-row-transaction-start-id-clause:

AS TRANSACTION START ID

as-row-transaction-timestamp-clause:

AS ROW BEGIN START END

as-generated-expression-clause:

AS (non-deterministic-expression)

non-deterministic-expression:



special-register:

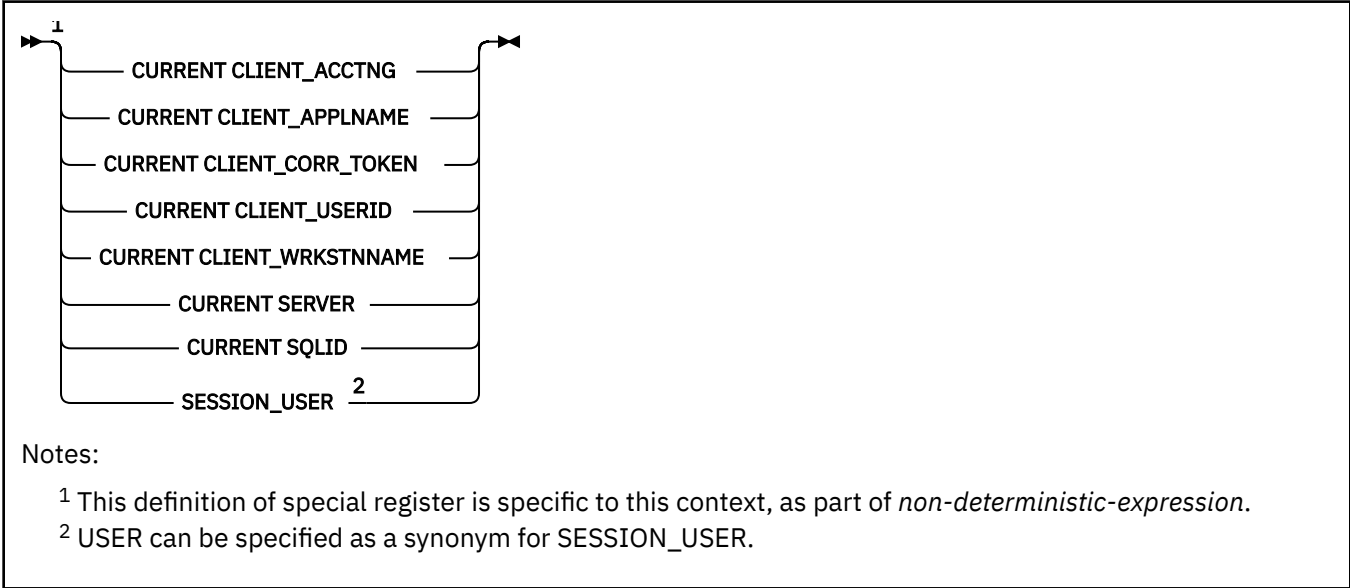

session-variable:

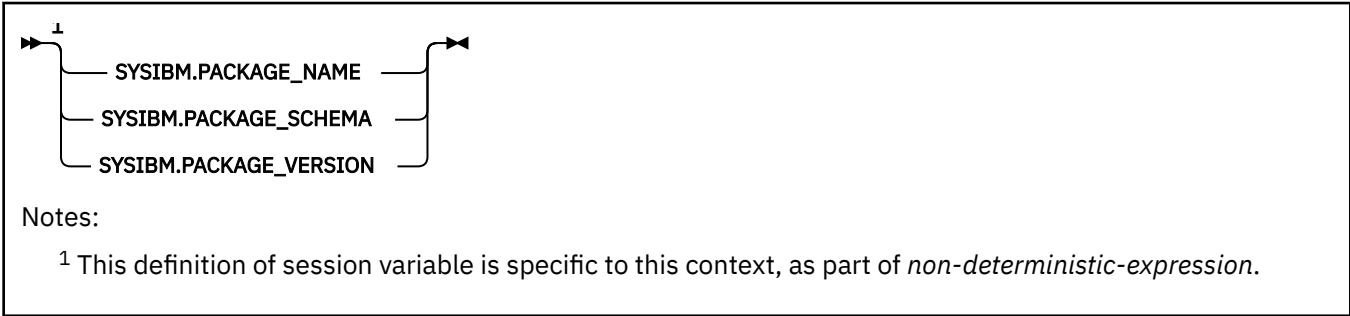

column-constraint:

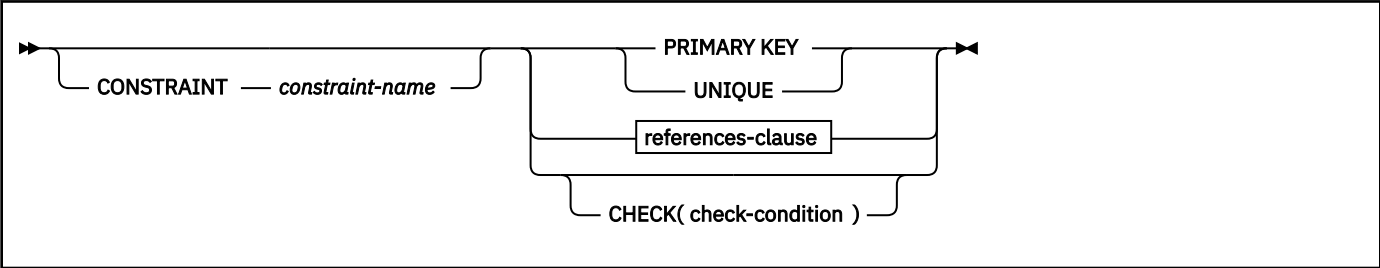

period-definition:

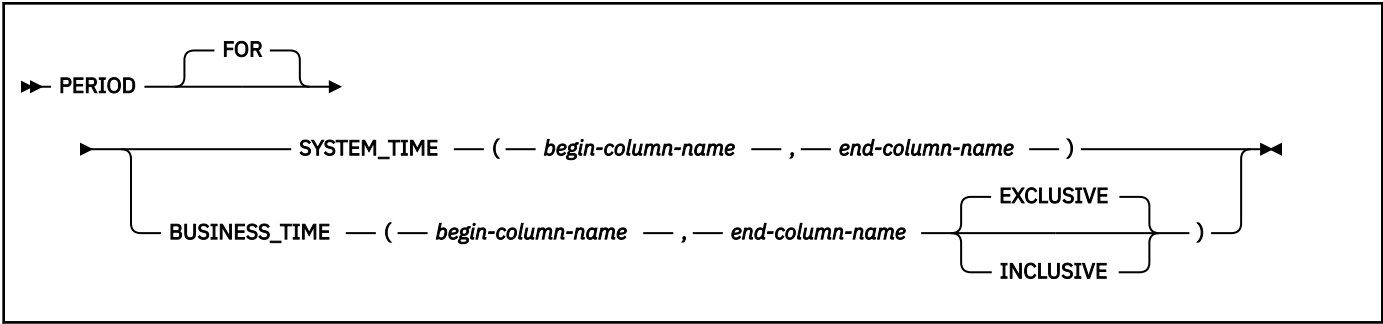

unique-constraint:

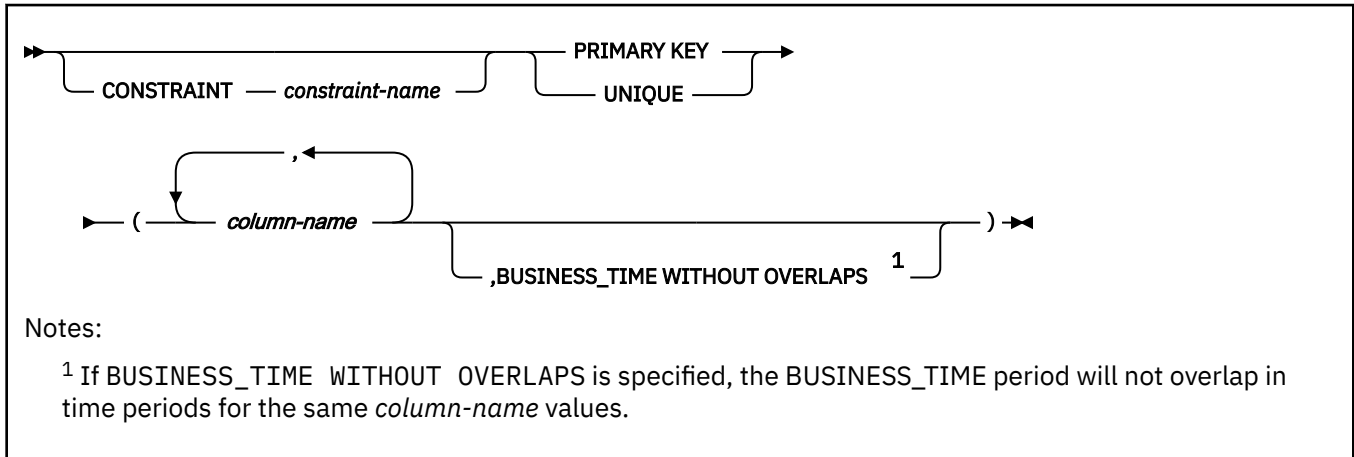

referential-constraint:

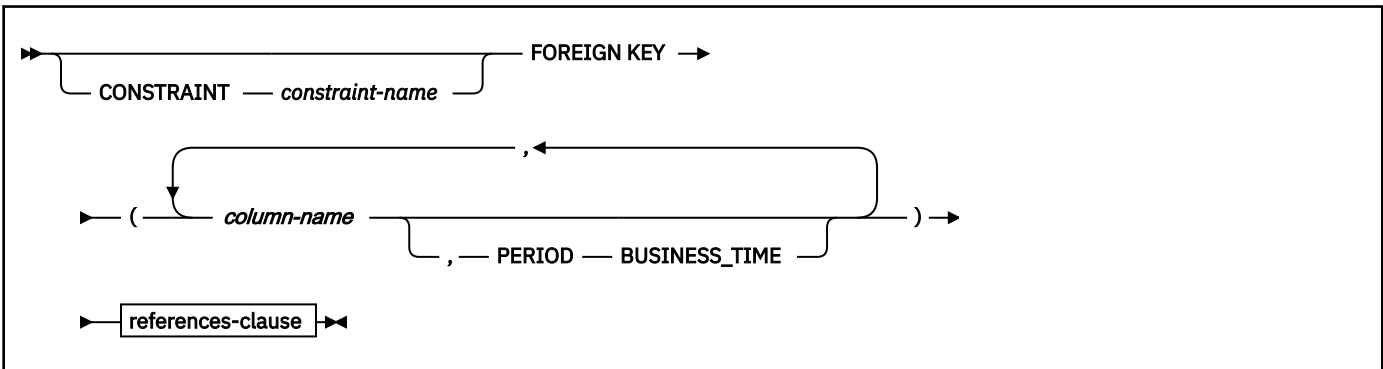

references-clause:

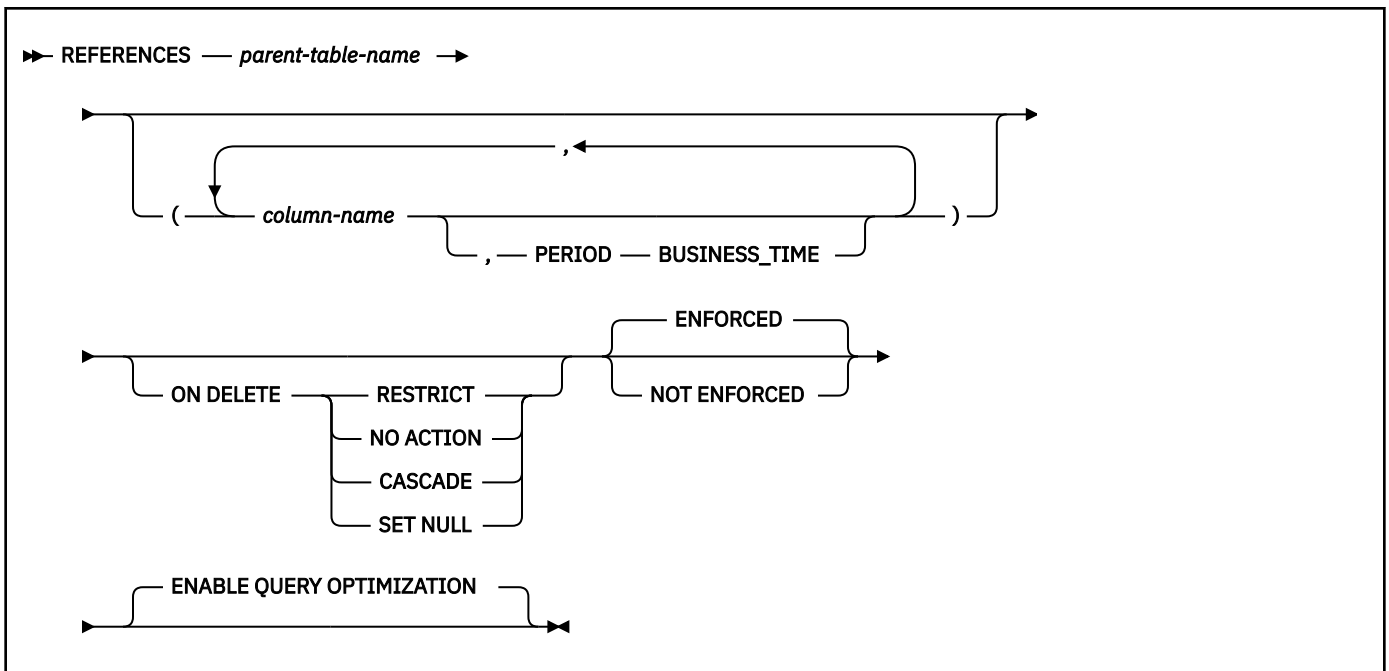

check-constraint:

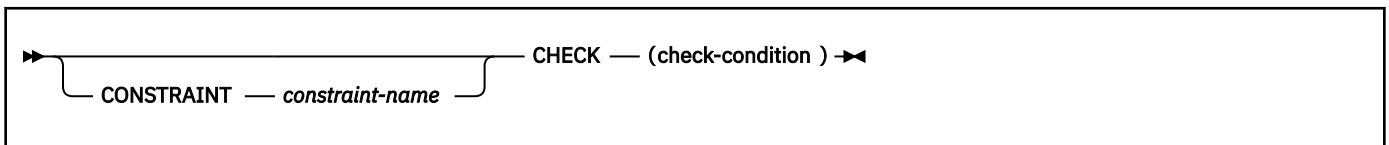

as-result-table:

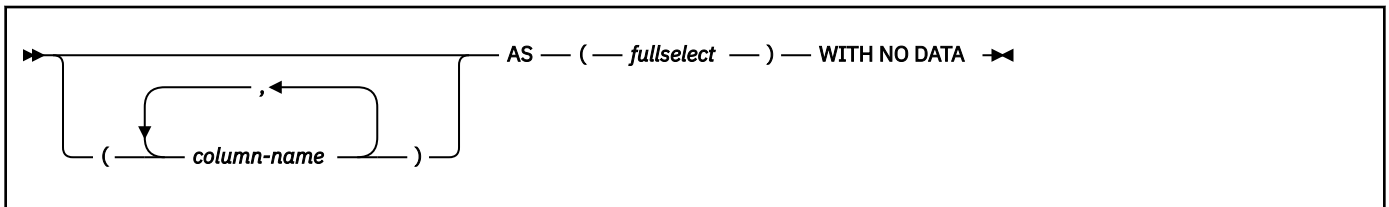

copy-options:

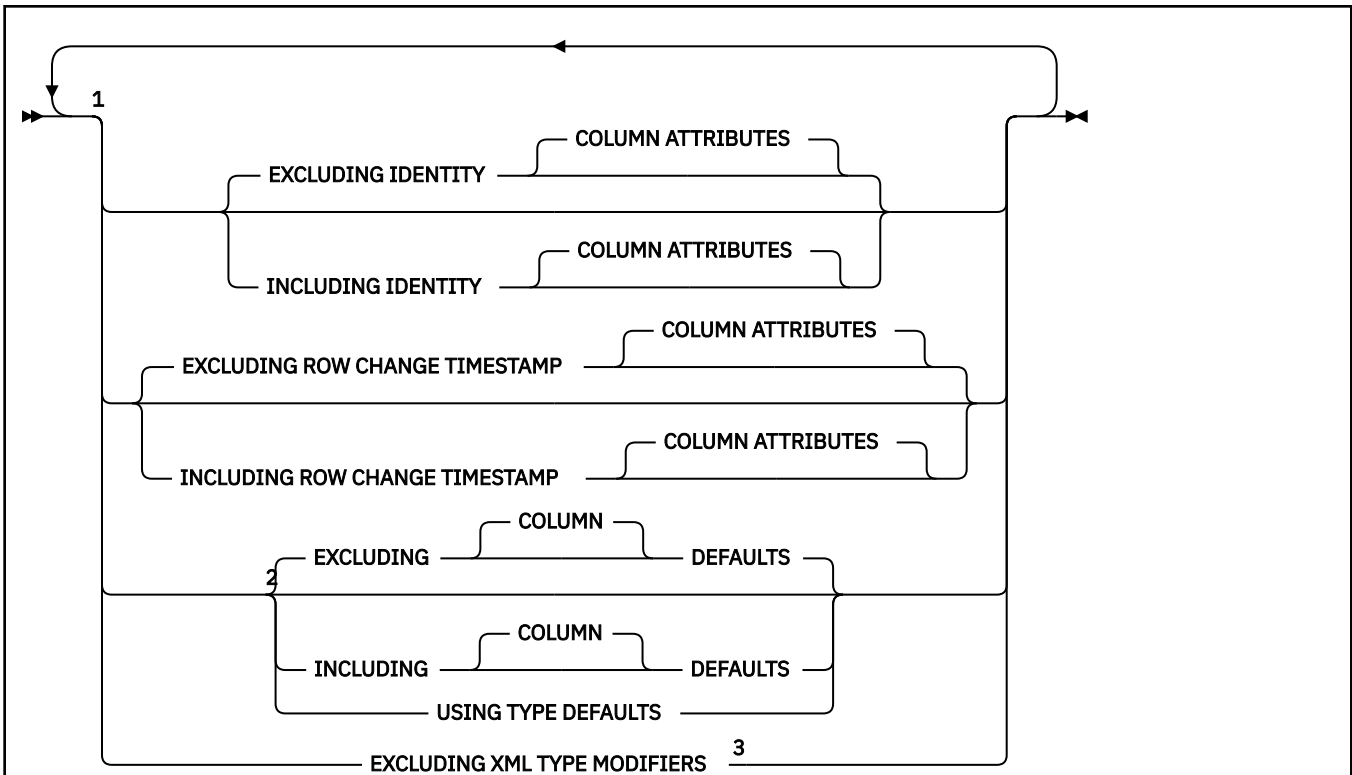

Notes:

- ¹ These clauses can be specified in any order and must not be specified more than one time.
- ² EXCLUDING COLUMN DEFAULTS, INCLUDING COLUMN DEFAULTS, and USING TYPE DEFAULTS must not be specified with the LIKE clause.
- ³ EXCLUDING XML TYPE MODIFIERS must be specified with the LIKE clause if the identified table has an XML type modifier and none of the XML columns of the new table has an XML type modifier. EXCLUDING XML TYPE MODIFIERS is not supported when a view is identified in a LIKE clause and the view contains XML columns.

materialized-query-definition

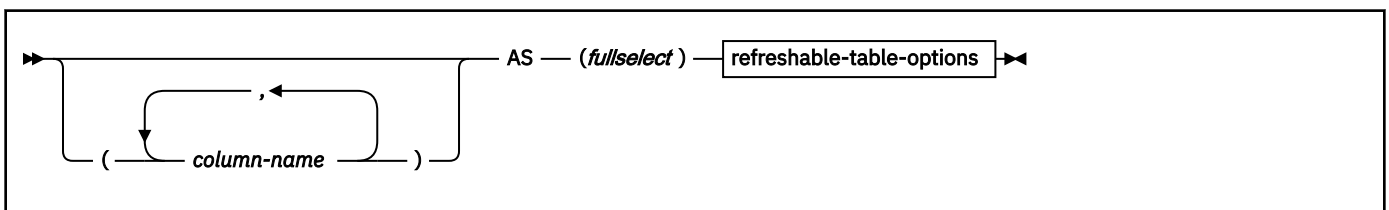

refreshable-table-options:

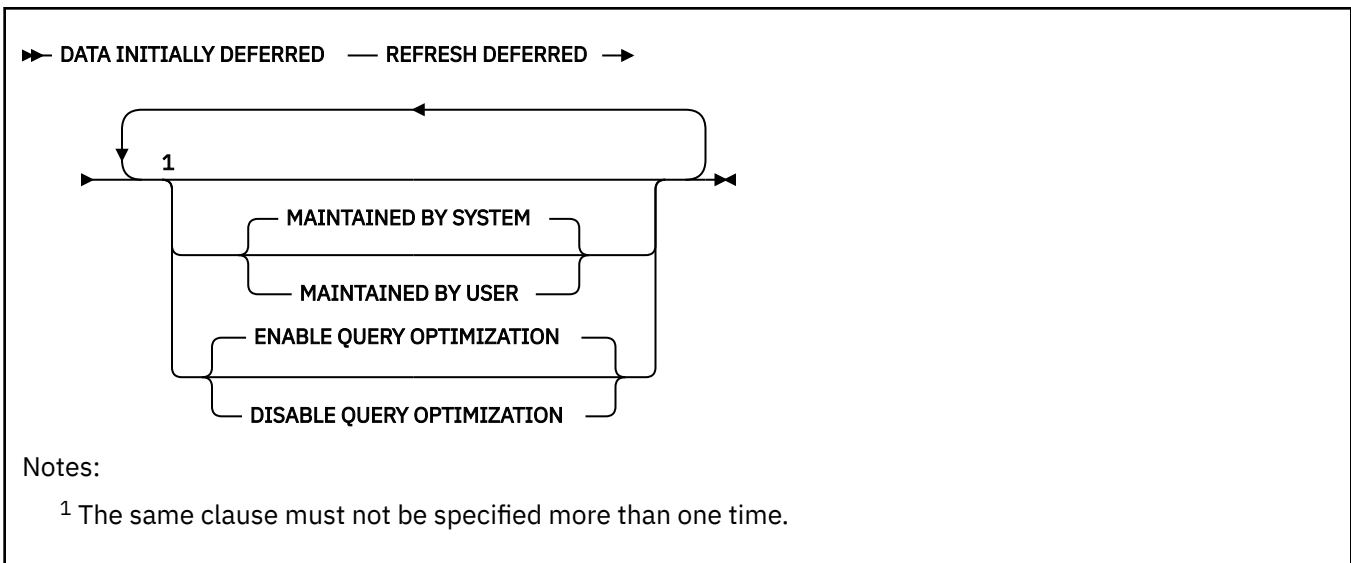

partitioning-clause:

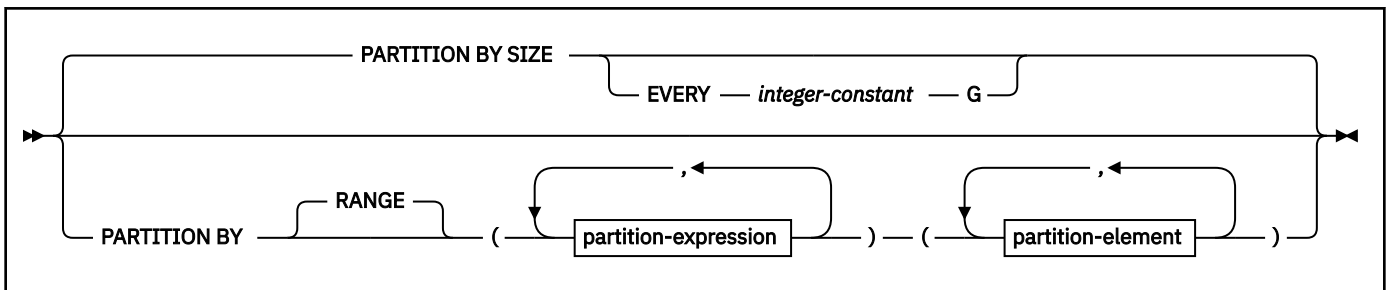

partition-expression:

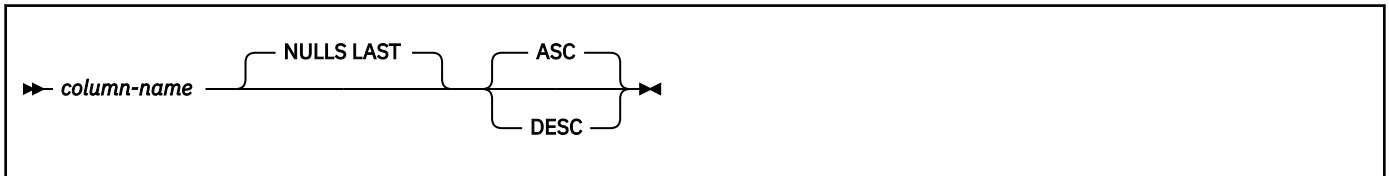

partition-element:

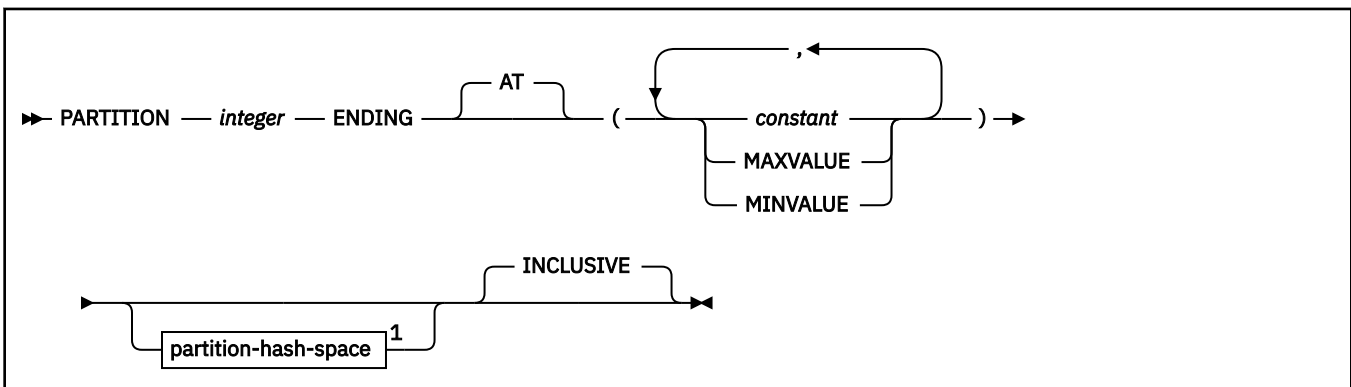

Notes:

¹ FL 504 Hash-organized tables are deprecated. Beginning in Db2 12, packages bound with APPLCOMPAT(V12R1M504) or higher cannot create hash-organized tables or alter existing tables to use hash-organization. Existing hash organized tables remain supported, but they are likely to be unsupported in the future.

Description for CREATE TABLE

table-name

Names the table. The name, including the implicit or explicit qualifier, must not identify a table, view, alias, or synonym that exists at the current server or a table that exists in the SYSIBM.SYSPENDINGOBJECTS catalog table. The unqualified name must not be the same as an existing synonym.

If the name is qualified, the name can be a two-part or three-part name. If a three-part name is used, the first part must match the value of field Db2LOCATION NAME on installation panel DSNTIPR at the current server. (If the current server is not the local Db2, this name is not necessarily the name in the CURRENT SERVER special register.)

For more information, see [Guidelines for table names \(Db2 Administration Guide\)](#).

FL 502 KEY LABEL *key-label-name* or NO KEY LABEL

Specifies whether key label is specified at the table level for encryption. The *table-name* must identify a table that resides in a universal table space, or a partitioned (non-UTS) table space. If you specify a *table-space-name* using the IN clause, a subsequent REORG of the table space is required for the key label value to take effect.

KEY LABEL *key-label-name*

Specifies the default key label that is used to encrypt all the table spaces and index spaces associated with the table. This includes base table spaces, auxiliary table spaces, XML table spaces, index spaces, and clone table spaces, regardless of whether they are explicitly or implicitly created. Users must set the key label for archive or history tables independently.

The data set must be Db2-managed for all the table spaces and index spaces associated with the table.

The *table-name* must not identify one of the following:

- An accelerator-only table.
- An auxiliary table.

The key label must be defined in ICSF. Db2 address space RACF user ID or group must be permitted access to the key label in RACF.

The key label can be inherited or overridden when the data set is allocated. For details about the order of precedence, see Notes®.

NO KEY LABEL

Indicates that there is no key label specified at the table level for encryption.

column-definition

column-name

Names a column of the table. For a dependent table, up to 749 columns can be named. For a table that is not a dependent, this number is 750. Do not qualify *column-name* and do not use the same name for more than one column of the table.

built-in-type

Specifies the data type of the column as one of the following built-in data types, and for character string data types, specifies the subtype. For more information about defining a table with a LOB column (CLOB, BLOB, or DBCLOB), see [Creating a table with LOB columns](#).

If IN ACCELERATOR is specified, not all data types are supported. For example, DECFLOAT, LOB, ROWID, TIMESTAMP WITH TIME ZONE, and XML are not supported. The *IBM Db2 Analytics Accelerator for z/OS: Stored Procedures Reference* has a complete list of supported data types.

SMALLINT

For a small integer.

INTEGER or INT

For a large integer.

BIGINT

For a big integer.

DECIMAL(*integer,integer*) or DEC(*integer,integer*)**DECIMAL(*integer*) or DEC(*integer*)****DECIMAL or DEC**

For a decimal number. The first integer is the precision of the number. That is, the total number of digits, which can range 1–31. The second integer is the scale of the number. That is, the number of digits to the right of the decimal point, which can range from 0 to the precision of the number.

You can use DECIMAL(*p*) for DECIMAL(*p*,0) and DECIMAL for DECIMAL(5,0).

You can also use the word NUMERIC instead of DECIMAL. For example, NUMERIC(8) is equivalent to DECIMAL(8). Unlike DECIMAL, NUMERIC has no allowable abbreviation.

DECFLOAT(*integer*)

For a decimal floating-point number. The value of *integer* must be either 16 or 34 and represents the number of significant digits that can be stored. If *integer* is omitted, the DECFLOAT column will be capable of representing 34 significant digits.

FLOAT(*integer*)**FLOAT**

For a floating-point number. If *integer* is in the range 1–21 inclusive, the format is single precision floating-point. If the integer is in the range 22–53 inclusive, the format is double precision floating-point.

You can use DOUBLE PRECISION or FLOAT for FLOAT(53).

REAL

For single precision floating-point.

DOUBLE or DOUBLE PRECISION

For double precision floating-point

CHARACTER(*integer*) or CHAR(*integer*)**CHARACTER or CHAR**

For a fixed-length character string of length *integer*, which can range 1–255. If the length specification is omitted, a length of 1 character is assumed.

CCSID 1208

Specifies that the column is a Unicode column encoded in UTF-8. This clause must not be specified for an ASCII or Unicode table.

VARCHAR(*integer*), CHAR VARYING(*integer*), or CHARACTER VARYING(*integer*)

For a varying-length character string of maximum length *integer*, which can range from 1 to the maximum record size minus 10 bytes. See [Table 208 on page 1707](#) to determine the maximum record size.

CCSID 1208

Specifies that the column is a Unicode column encoded in UTF-8. This clause must not be specified for an ASCII or Unicode table.

FOR *subtype* DATA

Specifies a subtype for a character string column, which is a column with a data type of CHAR, VARCHAR, or CLOB. Do not use the FOR *subtype* DATA clause with columns of any other data type (including any distinct type). *subtype* can be one of the following:

SBCS

Column holds single-byte data.

MIXED

Column holds mixed data. Do not specify MIXED if the value of field MIXED DATA on installation panel DSNTIPF is NO unless the CCSID UNICODE clause is also specified, or the table is being created in a Unicode table space or database.

BIT

Column holds BIT data. Do not specify BIT for a CLOB column.

Only character strings are valid when subtype is BIT.

If you do not specify the FOR *subtype* DATA clause, the column is defined with a default subtype. For ASCII or EBCDIC data:

- The default is SBCS when the value of field MIXED DATA on installation panel DSNTIPF is NO.
- The default is MIXED when the value is YES.

For Unicode data, the default subtype is MIXED.

A security label column is always considered SBCS data, regardless of the encoding scheme of the table.

CLOB(*integer* [K|M|G]), CHAR LARGE OBJECT(*integer* [K|M|G]), or CHARACTER LARGE OBJECT(*integer* [K|M|G])

CLOB, CHAR LARGE OBJECT, or CHARACTER LARGE OBJECT

For a character large object (CLOB) string of the specified maximum length in bytes. The maximum length must be in the range 1–2147483647. A CLOB column has a varying-length. It cannot be referenced in certain contexts regardless of its maximum length. For more information, see “Restrictions using LOBs” on page 117.

When *integer* is not specified, the default length is 1M. The maximum value that can be specified for *integer* depends on whether a units indicator is also specified as shown in the following list.

integer

The maximum value for *integer* is 2147483647. The maximum length of the string is *integer*.

***integer* K**

The maximum value for *integer* is 2097152. The maximum length is 1024 times *integer*.

***integer* M**

The maximum value for *integer* is 2048. The maximum length is 1,048,576 times *integer*.

***integer* G**

The maximum value for *integer* is 2. The maximum length is 1,073,741,824 times *integer*.

integer can be separated from K, M, or G by 0 or more spaces.

If you specify a value that evaluates to 2 gigabytes (2,147,483,648), Db2 uses a value that is one byte less, or 2147483647.

CCSID 1208

Specifies that the column is a Unicode column encoded in UTF-8. This clause must not be specified for an ASCII or Unicode table.

GRAPHIC(*integer*)

GRAPHIC

For a fixed-length graphic string of length *integer*, which can range 1–127. If the length specification is omitted, a length of 1 character is assumed.

CCSID 1200

Specifies that the column is a Unicode column encoded in UTF-16. This clause must not be specified for an ASCII or Unicode table.

VARGRAPHIC(*integer*)

For a varying-length graphic string of maximum length *integer*, which must range from 1 to $n/2$, where n is the maximum row size minus 2 bytes.

CCSID 1200

Specifies that the column is a Unicode column encoded in UTF-16. This clause must not be specified for an ASCII or Unicode table.

DBCLOB(*integer* [K|M|G])

DBCLOB

For a double-byte character large object (DBCLOB) string of the specified maximum length in double-byte characters. The maximum length must be in the range of 1–1,073,741,823. A

DBCLOB column has a varying-length. It cannot be referenced in certain contexts regardless of its maximum length. For more information, see [“Restrictions using LOBs” on page 117](#).

When *integer* is not specified, the default length is 1M. The meaning of *integer* K|M|G is similar to CLOB. The difference is that the number specified is the number of double-byte characters.

integer can be separated from K, M, or G by 0 or more spaces.

CCSID 1200

Specifies that the column is a Unicode column encoded in UTF-16. This clause must not be specified for an ASCII or Unicode table.

BINARY(*integer*)

A fixed-length binary string of length *integer*. The *integer* can range 1–255. If the length specification is omitted, a length of 1 byte is assumed.

BINARY VARYING(*integer*) or VARBINARY(*integer*)

A varying-length binary string of maximum length *integer*, which can range 1–32704. The length is limited by the page size of the table space.

BLOB (*integer* [K|M|G]) or BINARY LARGE OBJECT(*integer* [K|M|G])

BLOB or BINARY LARGE OBJECT

For a binary large object (BLOB) string of the specified maximum length in bytes. The maximum length must be in the range of 1–2147483647. A BLOB column has a varying-length. It cannot be referenced in certain contexts regardless of its maximum length. For more information, see [“Restrictions using LOBs” on page 117](#).

When *integer* is not specified, the default length is 1M. The meaning of *integer* K|M|G is the same as for CLOB.

integer can be separated from K, M, or G by 0 or more spaces.

DATE

For a date.

TIME

For a time.

TIMESTAMP(*integer*) WITHOUT TIME ZONE

For a timestamp. *integer* specifies the optional timestamp precision attribute and must be in the range 0–12. The timestamp precision denotes the number of fractional second digits that are included in the timestamp. The default is 6.

TIMESTAMP(*integer*) WITH TIME ZONE

For a timestamp with time zone. *integer* specifies the optional timestamp precision attribute and must be in the range 0–12. The timestamp precision denotes the number of fractional second digits that are included in the timestamp. The default is 6.

ROWID

For a row ID type.

A table can contain at most two ROWID columns. If it contains two, one column is implicitly generated by Db2 and the other column is explicitly defined as a ROWID without the IMPLICITLY HIDDEN attribute. The values in a ROWID column are unique for every row in the table and cannot be updated. You must specify NOT NULL with ROWID.

XML

For an XML document. Only well-formed XML documents can be inserted into an XML column.

If the XML column is the first XML column that you create for the table, a BIGINT DOCID column is implicitly created and is used to store a unique document identifier for the XML columns of a row.

XMLSCHEMA

Specifies one or more XML schemas that are used to validate the XML value. The same XML schema can not be specified more than one time.

If the XML value has already been validated, for example, the XML value is the result of the DSN_XMLVALIDATE function or from an XML column with a type modifier, and the XML schema

against which the XML value is validated is one of the schemas specified in the *XML-type-modifier*, Db2 accepts the XML value without revalidation.

XML-schema-specification

Specifies one XML schema. The XML schema can be identified by using either the *registered-XML-schema-name* or the schema's target namespace followed by an optional schema location. Any XML schema that is referenced in this clause must be registered in the XML schema repository prior to use.

ID registered-XML-schema-name

Identifies an XML schema by using its *registered-XML-schema-name*. The name must uniquely identify an existing XML schema in the XML schema repository at the current server. If no XML schema by this name exists, an error is returned.

The schema qualifier must be SYSXSR.

URI target-namespace

Specifies the target namespace URI of the XML schema. The value for the target-namespace URI is a character string constant which is not empty. The URI must be the target namespace of a registered XML schema and, if no LOCATION clause is specified, it must uniquely identify the registered XML schema.

NO NAMESPACE

Specifies that the XML schema has no target namespace. There must be a registered XML schema that has no target namespace. If no LOCATION clause is specified, there must be only one such registered XML schema.

LOCATION schema-location

Specifies the XML schema location URI of the XML schema. The value of *schema-location* is a character string constant that is not empty. The schema location URI, combined with the target namespace URI, must identify a registered XML schema.

ELEMENT element-name

Specifies the name of the global element declaration. *element-name* must match the local name of the root element node in the instance XML document. The namespace name of the root element node must be the same as the target namespace URI.

distinct-type-name

Specifies the data type of the column is a distinct type (a user-defined data type). The length, precision, and scale of the column are respectively the length, precision, and scale of the source type of the distinct type. The privilege set must implicitly or explicitly include the USAGE privilege on the distinct type.

The encoding scheme of the distinct type must be the same as the encoding scheme of the table. The subtype for the distinct type, if it has the attribute, is the subtype with which the distinct type was created.

If the column is to be used in the definition of the foreign key of a referential constraint, the data type of the corresponding column of the parent key must have the same distinct type.

NOT NULL

Prevents the column from containing null values. Omission of NOT NULL implies that the column can contain null values.

column-constraint

The *column-constraint* of a *column-definition* provides a shorthand method of defining a constraint composed of a single column. Thus, if a *column-constraint* is specified in the definition of column C, the effect is the same as if that constraint were specified as a *unique-constraint*, *referential-constraint*, or *check-constraint* in which C is the only identified column.

CONSTRAINT constraint-name

Names the constraint. If a constraint name is not specified, a unique constraint name is generated. If the name is specified, it must be different from the names of any referential, check, primary key, or unique key constraints previously specified on the table.

PRIMARY KEY

Provides a shorthand method of defining a primary key composed of a single column. Thus, if PRIMARY KEY is specified in the definition of column C, the effect is the same as if the PRIMARY KEY(C) clause is specified as a separate clause.

The NOT NULL clause must be specified with this clause. PRIMARY KEY cannot be specified more than one time in a column definition, and must not be specified if the UNIQUE clause is specified in the definition. This clause must also not be specified if the definition is for one of the following types of columns:

- a LOB column
- a ROWID column
- a distinct type column that is based on a LOB or ROWID data type
- an XML column
- a row change timestamp column
- a column in an accelerator-only table

The table is marked as unavailable until its primary index is explicitly created unless the CREATE TABLE statement is processed by the schema processor or the table space that contains the table is implicitly created. In that case, Db2 implicitly creates an index to enforce the uniqueness of the primary key and the table definition is considered complete. (For more information about implicitly created indexes, see [Implicitly created indexes.](#))

UNIQUE

Provides a shorthand method of defining a unique key composed of a single column. Thus, if UNIQUE is specified in the definition of column C, the effect is the same as if the UNIQUE(C) clause is specified as a separate clause.

The NOT NULL clause must be specified with this clause. UNIQUE cannot be specified more than one time in a column definition and must not be specified if the PRIMARY KEY clause is specified in the column definition or if the definition is for one of the following types of columns:

- a LOB column
- a ROWID column
- a distinct type column that is based on a LOB or ROWID data type
- an XML column
- a row change timestamp column
- a column in an accelerator-only table

The table is marked as unavailable until all the required indexes are explicitly created unless the CREATE TABLE statement is processed by the schema processor or the table space that contains the table is implicitly created. In that case, Db2 implicitly creates the indexes that are required for the unique keys and the table definition is considered complete. (For more information about implicitly created indexes, see [Implicitly created indexes.](#))

references-clause

The *references-clause* of a *column-definition* provides a shorthand method of defining a foreign key composed of a single column. Thus, if *references-clause* is specified in the definition of column C, the effect is the same as if the *references-clause* were specified as part of a FOREIGN KEY clause in which C is the only identified column.

Do not specify *references-clause* in the definition of the following types of columns because these types of columns cannot be a foreign key:

- a LOB column
- a ROWID column
- a DECFLOAT column
- a distinct type column that is based on a LOB, ROWID, or DECFLOAT data type

- an XML column
- a row change timestamp column
- a security label column

CHECK (*check-condition*)

CHECK (*check-condition*) provides a shorthand method of defining a check constraint that applies to a single column. For conformance with the SQL standard, if CHECK is specified in the column definition of column C, no columns other than C should be referenced in the check condition of the check constraint. The effect is the same as if the check condition were specified as a separate clause.

DEFAULT

Specifies the default value that is assigned to the column in the absence of a value specified on an insert or update operation or LOAD. DEFAULT must not be specified more than one time in the same *column-definition*. Do not specify DEFAULT for the following types of columns because Db2 generates default values:

- An identity column (a column that is defined AS IDENTITY)
- A ROWID column (or a distinct type that is based on a ROWID)
- A row change timestamp column
- A row-begin column
- A row-end column
- A *transaction-start-id* column
- An XML column

If IN ACCELERATOR is specified, do not specify DEFAULT for a column.

Do not specify a value after the DEFAULT keyword for a security label column. Db2 provides the default value for a security label column.

If a value is not specified after DEFAULT, the default value depends on the data type of the column, as follows:

Data Type

Default Value

Numeric

0

Big integer

0

Fixed-length character string

Blanks

Fixed-length graphic string

Blanks

Fixed-length binary string

Hexadecimal zeros

Varying-length string

A string of length 0

Inline BLOB

Hexadecimal zeros

Inline CLOB

Blanks

Inline DBCLOB

Blanks

Date

CURRENT DATE

Time

CURRENT TIME

TIMESTAMP(*integer*) WITHOUT TIME ZONE

CURRENT TIMESTAMP(*p*) WITHOUT TIME ZONE where *p* is the corresponding timestamp precision.

TIMESTAMP(*integer*) WITH TIME ZONE

CURRENT TIMESTAMP(*p*) WITH TIME ZONE where *p* is the corresponding timestamp precision.

If the column is defined as timestamp with time zone the default value must include a time zone.

Distinct type

The default of the source data type

A default value other than the one that is listed above can be specified in one of the following forms:

- WITH DEFAULT for a default value of an empty string
- DEFAULT NULL for a default value of null

Omission of NOT NULL and DEFAULT from a *column-definition*, for a column other than an identity column, is an implicit specification of DEFAULT NULL. For an identity column, it is an implicit specification of NOT NULL, and Db2 generates default values.

constant

Specifies a constant as the default value for the column. The value of the constant must conform to the rules for assigning that value to the column.

A character or graphic string constant must be short enough so that its UTF-8 representation requires no more than 1536. A hexadecimal graphic string constant (GX) cannot be specified.

In addition, the length of the constant value cannot be greater than the INLINE LENGTH attribute for LOB columns.

SESSION_USER or USER

Specifies the value of the SESSION_USER (USER) special register at the time of an SQL data change statement or LOAD as the default value for the column. If SESSION_USER is specified, the data type of the column must be a character string with a length attribute greater than or equal to 8 characters when the value is expressed in CCSID 37. If the data type of the column is an inline CLOB, the INLINE LENGTH attribute must be greater than or equal to 8 characters when the value is expressed as CCSID 37.

CURRENT SQLID

Specifies the value of the SQL authorization ID of the process at the time of an insert or update operation or LOAD as the default value for the column. If CURRENT SQLID is specified, the data type of the column must be a character string with a length attribute greater than or equal to the length attribute of the CURRENT SQLID special register. If the data type of the column is an inline CLOB, the INLINE LENGTH attribute must be greater than or equal to the length attribute of the CURRENT SQLID special register.

NULL

Specifies null as the default value for the column. If NOT NULL is specified, DEFAULT NULL must not be specified with the same *column-definition*.

cast-function-name

The name of the cast function that matches the name of the distinct type for the column. A cast function can only be specified if the data type of the column is a distinct type.

The schema name of the cast function, whether it is explicitly specified or implicitly resolved through function resolution, must be the same as the explicitly or implicitly specified schema name of the distinct type.

constant

Specifies a constant as the argument. The constant must conform to the rules of a constant for the source type of the distinct type. The length of the constant cannot be greater than the INLINE LENGTH attribute for LOB columns.

SESSION_USER or USER

Specifies the value of the SESSION_USER (USER) special register at the time a row is inserted as the default for the column. The source type of the distinct type of the column must be a CHAR, VARCHAR, or inline CLOB with a length attribute (inline length attribute for CLOB) that is greater than or equal to the length attribute of the SESSION_USER special register.

CURRENT SQLID

Specifies the value of the CURRENT SQLID special register at the time a row is inserted as the default for the column. The source type of the distinct type of the column must be a CHAR, VARCHAR, or inline CLOB with a length attribute (or inline length attribute for CLOB) that is greater than or equal to the length attribute of the CURRENT SQLID special register.

NULL

Specifies the NULL value as the argument.

In a given column definition:

- DEFAULT and FIELDPROC cannot both be specified.
- NOT NULL and DEFAULT NULL cannot both be specified.

Table 204 on page 1671 summarizes the effect of specifying the various combinations of the NOT NULL and DEFAULT clauses on the CREATE TABLE statement *column-description* clause.

Table 204. Effect of specifying combinations of the NOT NULL and DEFAULT clauses

If NOT NULL is:	And DEFAULT is:	The effect is:
Specified ¹	Omitted	An error occurs if a value is not provided for the column on an insert or update operation or LOAD.
	Specified without an operand	The system defined nonnull default value is used.
	<i>constant</i>	The specified constant is used as the default value.
	SESSION_USER	The value of the SESSION_USER special register at the time of an insert or update operation or LOAD is used as the default value.
	CURRENT SQLID	The SQL authorization ID of the process at the time of an insert or update operation or LOAD is used as the default value.
	NULL	An error occurs during the execution of CREATE TABLE.

Table 204. Effect of specifying combinations of the NOT NULL and DEFAULT clauses (continued)

If NOT NULL is:	And DEFAULT is:	The effect is:
Omitted	Omitted	Equivalent to an implicit specification of DEFAULT NULL.
	Specified without an operand	The system defined nonnull default value is used.
	<i>constant</i>	The specified constant is used as the default value.
	SESSION_USER	The value of the SESSION_USER special register at execution time is used as the default value.
	CURRENT SQLID	The SQL authorization ID of the process is used as the default value.
	NULL	Null is used as the default value.

Note: The table does not apply to a column with a ROWID data type or to an identity column.

GENERATED

Specifies that Db2 generates values for the column. GENERATED must be specified if the column is to be considered one of the following types of columns:

- An identity column
- A row change timestamp column.
- A ROWID column
- A row-begin column
- A row-end column
- A *transaction-start-id* column
- A generated expression column

GENERATED must only be specified for these types of columns. GENERATED must not be specified with *default-clause* in a column definition.

GENERATED must not be specified if the column definition references global variables.

ALWAYS

Specifies that Db2 always generates a value for the column when a row is inserted or updated and a default value must be generated. ALWAYS is the default and recommended value.

BY DEFAULT

Specifies that Db2 will generate a value for the column when a row is inserted or updated and a default value must be generated, unless an explicit value is specified.

For a row change timestamp column, Db2 inserts or updates a specified value but does not verify that the value is unique for the column unless the row change timestamp column has a unique constraint or a unique index that specifies only the row change timestamp column.

For a ROWID column, Db2 uses a specified value only if it is a valid row ID value that was previously generated by Db2 and the column has a unique, single-column index. Until this index is created on the ROWID column, the SQL insert or update operation and the LOAD utility cannot be used to add rows to the table. If the table space is explicitly created and the value of the CURRENT RULES special register is 'STD' when the CREATE TABLE statement is processed, or if the table space is implicitly created, Db2 implicitly creates the index on the ROWID column. The name of this index is 'I' followed by the first ten characters of the column name followed by seven randomly generated characters. If the column name is less than ten characters, Db2 adds

underscore characters to the end of the name until it has ten characters. The implicitly created index has the COPY NO attribute.

For an identity column, Db2 inserts a specified value but does not verify that it is a unique value for the column unless the identity column has a unique, single-column index.

BY DEFAULT is the recommended value only when you are using data propagation.

FOR EACH ROW ON UPDATE AS ROW CHANGE TIMESTAMP

Specifies that the column is a timestamp column for the table. Db2 generates a value for the column for each row as the row is inserted, and for any row in which any column is updated. The value that is generated for a row change timestamp column is a timestamp that corresponds to the insert or update time of the row. If multiple rows are inserted or updated with a single statement, the value for the row change timestamp column might be different for each row.

A table can only have one row change timestamp column.

If *data-type* is specified, it must be `TIMESTAMP WITHOUT TIME ZONE` with a precision of 6.

A row change timestamp column cannot have a `DEFAULT` clause. `NOT NULL` must be specified for a row change timestamp column.

AS TRANSACTION START ID

Specifies that the value is assigned by Db2 whenever a row is inserted into the table or any column in the row is updated. Db2 assigns a unique timestamp value per transaction or the null value. The null value is assigned to the transaction-start-ID column if the column is nullable. Otherwise, the value is generated using the time-of-day clock during execution of the first data change statement in the transaction that requires a value to be assigned to a row-begin column or transaction-start-ID column in the table, or when a row in a system-period temporal table is deleted. If multiple rows are inserted or updated within a single SQL transaction, the values for the transaction-start-ID column are the same for all the rows and are unique from the values that are generated for the column for another transaction.

A transaction-start-ID column is required for a system-period temporal table.

A table can have only one transaction-start-ID column. If a data type is not specified, the column is defined as `TIMESTAMP(12) WITHOUT TIME ZONE`. If a data type is specified, it must be `TIMESTAMP(12) WITHOUT TIME ZONE` or `TIMESTAMP(12) WITH TIME ZONE`. If the column is defined as `TIMESTAMP WITH TIME ZONE`, the values are stored in UTC, with a time zone of `+00:00`. A transaction-start-ID column cannot have a `DEFAULT` clause. A transaction-start-ID column is not updatable.

A value for a transaction-start-ID column is composed of a `TIMESTAMP(9)` value that is unique per transaction per data sharing member followed by 3 digits that indicate the data sharing member number.

AS ROW BEGIN

Specifies that a timestamp value is assigned to the column whenever a row is inserted or any column in the row is updated. If the value of the `SYSIBM.TEMPORAL_LOGICAL_TRANSACTION_TIME` built-in global variable at the time of the insert or update is null, the value is generated using a reading of the time-of-day clock during execution of the first data change statement in the unit of work that requires a value to be assigned to a row-begin column or transaction-start-ID column in a table, or a row in a system-period temporal table is deleted. Otherwise, the row-begin column is assigned the value of the `SYSIBM.TEMPORAL_LOGICAL_TRANSACTION_TIME` built-in global variable at the time of the insert or update.

A *row-begin* column is intended to be used for a system-period temporal table.

A table can have only one column defined as `AS ROW BEGIN`. If a data type is specified, it must be `TIMESTAMP(12) WITHOUT TIME ZONE` or `TIMESTAMP(12) WITH TIME ZONE`. If the column is defined as `TIMESTAMP(12) WITH TIME ZONE`, the values are stored in UTC, with a time zone of `+00:00`. If no data type is specified, the column is defined as `TIMESTAMP(12) WITHOUT TIME`

ZONE. A column defined as a row-begin column cannot have a DEFAULT clause, and must be defined as NOT NULL.

A row-begin column is not updatable.

A value for a row-begin column is composed of a TIMESTAMP(9) value that is unique per transaction per data sharing member followed by 3 digits that indicate the data sharing member number.

AS ROW END

Specifies that a value for the data type of the column is assigned by Db2 whenever a row is inserted or any column in the row is updated. The value that is assigned for a TIMESTAMP WITHOUT TIME ZONE column is the TIMESTAMP value '9999-12-30-00.00.00.000000000000'. The value that is assigned for a TIMESTAMP WITH TIME ZONE column is the TIMESTAMP value '9999-12-30-00.00.00.000000000000 +00:00'.

A row-end column is required as the second column of a SYSTEM_TIME period.

A table can have only one row-end column. If a data type is not specified, the column is defined as TIMESTAMP(12) WITHOUT TIME ZONE. If a data type is specified, it must be TIMESTAMP(12) WITHOUT TIME ZONE or TIMESTAMP(12) WITH TIME ZONE. If the column is defined as TIMESTAMP WITH TIME ZONE, the values are stored in UTC, with a time zone of +00:00. A row-end column cannot have a DEFAULT clause and must be defined as NOT NULL. A row-end column is not updatable.

as-generated-expression-clause

Specifies that values for the column are generated by Db2. The generated value is assigned to the column whenever a row is inserted, or any column in the row is updated.

DATA CHANGE OPERATION

Specifies that the database manager generates one of the following values, depending on the specified expression:

- I** Insert operation.
- U** Update operation.
- D** Delete operation.

A table can have only one DATA CHANGE OPERATION column. The column must be defined as CHAR(1). The column cannot have a DEFAULT clause and must not be defined as NOT NULL.

The column is a non-deterministic generated expression column.

Do not specify any of the following clauses for the column:

- CCSID 1200
- CCSID 1208
- FIELDPROC

special-register

Specifies the value of the special register. The column is to contain the value of the special register at the time of the data change statement that assigns the value to the column. If multiple rows are inserted or updated with a single SQL statement, the value for the column is the same for all of the rows.

special-register must be one of the following special registers, and the column must use the required data type.

Table 205. Possible special register values for non-deterministic generated expression columns

Special register	Data type for the column
CURRENT CLIENT_ACCTNG	VARCHAR(255)
CURRENT CLIENT_APPLNAME	VARCHAR(255)
CURRENT CLIENT_CORR_TOKEN	VARCHAR(255)
CURRENT CLIENT_USERID	VARCHAR(255)
CURRENT CLIENT_WRKSTNNAME	VARCHAR(255)
CURRENT SERVER	CHAR(16)
CURRENT SQLID	VARCHAR(<i>n</i>) where $n \geq 8$
SESSION_USER or USER	VARCHAR(128)

The column cannot have a DEFAULT clause and must not be defined as NOT NULL.

The column is a non-deterministic generated expression column.

Do not specify any of the following clauses for the column:

- CCSID 1200
- CCSID 1208
- FIELDPROC

For more information, see [“Special registers” on page 177](#).

session-variable

Specifies the value of a built-in session variable. The fully qualified name of the session variable must be specified. The value of the session variable is obtained from the GETVARIABLE function at the time of the data change operation that assigns the value to the column. If multiple rows are changed with a single SQL statement, the value for the column is the same for all of the rows.

session-variable must be one of the following session variables, and the column must use the required data type.

Table 206. Possible session variable values for non-deterministic generated expression columns

Session variable	Data type for the column
SYSIBM.PACKAGE_NAME	VARCHAR(128)
SYSIBM.PACKAGE_SCHEMA	VARCHAR(128)
SYSIBM.PACKAGE_VERSION	VARCHAR(122)

The column cannot have a DEFAULT clause and must not be defined as NOT NULL.

The column is a non-deterministic generated expression column.

Do not specify any of the following clauses for the column:

- CCSID 1200
- CCSID 1208
- FIELDPROC

For more information, see [“Built-in session variables” on page 336](#).

AS IDENTITY

Specifies that the column is an identity column for the table. A table can have only one identity column. AS IDENTITY can be specified only if the data type for the column is an exact numeric type with a scale of zero (SMALLINT, INTEGER, BIGINT, DECIMAL with a scale of zero, or a distinct type based on one of these types).

An identity column is implicitly NOT NULL. An identity column cannot have a WITH DEFAULT clause.

Defining a column AS IDENTITY does not necessarily ensure the uniqueness of the values. To ensure uniqueness of the values, define a unique, single-column index on the identity column.

If IN ACCELERATOR is specified, AS IDENTITY must not be specified.

START WITH *numeric-constant*

Specifies the first value that is generated for the identity column. The value can be any positive or negative value that could be assigned to the column without non-zero digits existing to the right of the decimal point.

If a value is not explicitly specified when the identity column is defined, the default is the MINVALUE for an ascending identity column and the MAXVALUE for a descending identity column. This value is not necessarily the value that would be cycled to after reaching the maximum or minimum value for the identity column. The range used for cycles is defined by MINVALUE and MAXVALUE. MAXVALUE and MINVALUE do not constrain the numeric-constant value. That is, the START WITH clause can be used to start the generation of values outside the range that is used for cycles. However, the next generated value after the specified START WITH value is MINVALUE for an ascending identity column or MAXVALUE for a descending identity column.

INCREMENT BY *numeric-constant*

Specifies the interval between consecutive values of the identity column. The value can be any positive or negative value (including 0) that does not exceed the value of a large integer constant, and could be assigned to the column without any non-zero digits existing to the right of the decimal point.

If this value is negative, the values for the identity column descend. If this value is 0 or positive, the values for the identity column ascend. The default is 1.

MINVALUE or NO MINVALUE

Specifies the minimum value at which a descending identity column either cycles or stops generating values or an ascending identity column cycles to after reaching the maximum value.

NO MINVALUE

Specifies that the minimum end point of the range of values for the identity column has not been set. In such a case, the default value for MINVALUE becomes one of the following:

- For an ascending identity column, the value is the START WITH value or 1 if START WITH is not specified.
- For a descending identity column, the value is the minimum value of the data type of the column.

The default is NO MINVALUE.

MINVALUE *numeric-constant*

Specifies the numeric constant that is the minimum value that is generated for this identity column. This value can be any positive or negative value that could be assigned to this column without non-zero digits existing to the right of the decimal point. The value must be less than or equal to the maximum value.

MAXVALUE or NO MAXVALUE

Specifies the maximum value at which an ascending identity column either cycles or stops generating values or a descending identity column cycles to after reaching the minimum value.

NO MAXVALUE

Specifies that the minimum end point of the range of values for the identity column has not be set. In such a case, the default value for MAXVALUE becomes one of the following:

- For an ascending identity column, the value is the maximum value of the data type associated with the column.
- For a descending identity column, the value is the START WITH value -1 if START WITH is not specified.

The default is NO MAXVALUE.

MAXVALUE *numeric-constant*

Specifies the numeric constant that is the maximum value that is generated for this identity column. This value can be any positive or negative value that could be assigned to this column without non-zero digits existing to the right of the decimal point. The value must be greater than or equal to the minimum value.

CYCLE or NO CYCLE

Specifies whether this identity column should continue to generate values after reaching either its maximum or minimum value. The default is NO CYCLE.

NO CYCLE

Specifies that values will not be generated for the identity column after the maximum or minimum value has been reached.

CYCLE

Specifies that values continue to be generated for the identity column after the maximum or minimum value has been reached. If this option is used, after an ascending identity column reaches the maximum value, it generates its minimum value. After a descending identity column reaches its minimum value, it generates its maximum value. The maximum and minimum values for the identity column determine the range that is used for cycling.

When CYCLE is in effect, duplicate values can be generated by Db2 for an identity column. However, if a unique index exists on the identity column and a non-unique value is generated for it, an error occurs.

CACHE *integer-constant* or NO CACHE

Specifies whether to keep some preallocated values in memory. Preallocating and storing values in the cache improves the performance of inserting rows into a table. The default is CACHE 20.

In a non-data sharing environment, if the system is shut down (either normally or through a system failure), all cached sequence values that have not been used in committed statements are lost (that is, they will never be used). The value specified for the CACHE option is the maximum number of sequence values that could be lost when the system is shut down.

In a data sharing environment, you can use the CACHE and NO ORDER options to allow multiple Db2 members to cache sequence values simultaneously.

NO CACHE

Specifies that values for the identity column and sequences are not preallocated and stored in the cache, ensuring that values will not be lost in the case of a system failure. In this case, every request for a new value for the identity column or sequence results in synchronous I/O.

In a data sharing environment, use NO CACHE if you need to guarantee that the identity column and sequence values are generated in the order in which they are requested.

CACHE *integer-constant*

Specifies the maximum number of values of the identity column sequence that Db2 can preallocate and keep in memory.

During a Db2 shutdown, all cached identity column values and sequence values that are yet to be assigned will be lost and will not be used. Therefore, the value that is specified

for CACHE also represents the maximum number of identity column values and sequence values that will be lost during a Db2 shutdown.

The minimum value is 2.

In a data sharing environment, you can use the CACHE and NO ORDER options to allow multiple Db2 members to cache sequence values simultaneously.

ORDER or NO ORDER

Specifies whether the identity column values must be generated in order of request. The default is NO ORDER.

In a non-data sharing environment, there is no guarantee that values are assigned in order across the entire server unless NO CACHE is also specified. ORDER applies only to a single-application process.

In a data sharing environment, if ORDER is specified, NO CACHE is implicitly set, even if CACHE integer-constant is specified.

NO ORDER

Specifies that the values do not need to be generated in order of request.

ORDER

Specifies that the values are generated in order of request. Specifying ORDER might disable the caching of values. ORDER applies only to a single-application process.

In a data sharing environment, if the CACHE and NO ORDER options are in effect, multiple caches can be active simultaneously, and the requests for identity values from different Db2 members might not result in the assignment of values in strict numeric order. For example, if members DB2A and DB2B are using the identity column, and DB2A gets the cache values 1 to 20 and DB2B gets the cache values 21 to 40, the actual order of values assigned would be 1,21,2 if DB2A requested a value first, then DB2B requested, and then DB2A again requested. Therefore, to guarantee that identity values are generated in strict numeric order among multiple Db2 members using the same identity column, specify the ORDER option.

FIELDPROC *program-name*

Designates *program-name* as the field procedure exit routine for the column. A field procedure can be specified only for a column with a length attribute that is not greater than 255 bytes. FIELDPROC can only be specified for columns that are a built-in character string or graphic string data types. The column must not be one of the following:

- a LOB column
- a security label column
- a row change timestamp column
- a column with the TIMESTAMP WITH TIME ZONE data type
- a Unicode column in an EBCDIC table
- a column in an accelerator-only table

The field procedure encodes and decodes column values: before a value is inserted in the column, it is passed to the field procedure for encoding. Before a value from the column is used by a program, it is passed to the field procedure for decoding. A field procedure could be used, for example, to alter the sorting sequence of values entered in the column.

The field procedure is also invoked during the processing of the CREATE TABLE statement. When so invoked, the procedure provides Db2 with the column's *field description*. The field description defines the data characteristics of the encoded values. By contrast, the information you supply for the column in the CREATE TABLE statement defines the data characteristics of the decoded values.

For more information, see:

[Field procedures \(Db2 Administration Guide\)](#)
[“String comparisons” on page 157](#)

constant

Is a parameter that is passed to the field procedure when it is invoked. A parameter list is optional. The *n*th parameter specified in the FIELDPROC clause on CREATE TABLE corresponds to the *n*th parameter of the specified field procedure. The maximum length of the parameter list is 254 bytes, including commas but excluding insignificant blanks and the delimiting parentheses.

If you omit FIELDPROC, the column has no field procedure.

AS SECURITY LABEL

Specifies that the column will contain security label values. This also indicates that the table is defined with multilevel security with row level granularity. A table can have only one security label column. A security label column cannot be defined for an accelerator-only table. To define a table with a security label column, the primary authorization ID of the statement must have a valid security label, and the RACF SECLABEL class must be active. In addition, the following conditions are also required:

- The data type of the column must be CHAR(8).
- The subtype of the column must be SBCS.
- The column must be defined with the NOT NULL and WITH DEFAULT clauses.
- The column must be an EBCDIC column.
- The WITH DEFAULT clause must not specify a default value (Db2 determines the default value)
- No field procedures, check constraints, or referential constraints are defined on the column.
- No edit procedure for the table can be defined with row attribute sensitivity.

For information about using multilevel security, see [Multilevel security \(Managing Security\)](#).

IMPLICITLY HIDDEN

Specifies that the column is not visible in the result for SQL statements unless you explicitly refer to the column by name. For example, assuming that the table T1 includes a column that is defined with the IMPLICITLY HIDDEN clause, the result of a SELECT * would not include the implicitly hidden column. However, the result of a SELECT statement that explicitly refers to the name of the implicitly hidden column would include that column in the result table.

IMPLICITLY HIDDEN must not be specified for a column that is defined as a ROWID, or a distinct type that is based on a ROWID. IMPLICITLY HIDDEN must not be specified for all columns of a table. If IN ACCELERATOR is specified, IMPLICITLY HIDDEN must not be specified.

INLINE LENGTH *integer*

Specifies the maximum length of the inline portion of a LOB column value. The inline portion is the portion that is stored in the base table space. INLINE LENGTH cannot be specified if the column is not a LOB column (or a distinct type that is based on a LOB), if the table is not in a universal table space, or if the table is an accelerator-only table.

For BLOB and CLOB columns, *integer* specifies the maximum number of bytes that are stored in the base table space for the column. *integer* must be in the range 0–32680 (inclusive) for a BLOB or CLOB column.

For a DBCLOB column, *integer* specifies the maximum number of double-byte characters that are stored in the table space for the column. *integer* must be in the range 0–16340 (inclusive) for a DBCLOB column.

If INLINE LENGTH is specified, the value of *integer* cannot be greater than the maximum length of the LOB column.

If the INLINE LENGTH clause is not specified, the maximum length of the LOB column depends on the following conditions:

- If a distinct type is not used or the distinct type that is used has been created without the INLINE LENGTH attribute, the LOB column will use the value of the LOB INLINE LENGTH parameter on installation panel DSNTIPD as the default inline length when the value of LOB INLINE LENGTH does not exceed the maximum length of the LOB column. If the value of LOB INLINE LENGTH exceeds the maximum length of the LOB column, the maximum length is the inline length of this LOB column.

- If a distinct type that has been created with the `INLINE LENGTH` attribute is used, the LOB column inherits the inline length from the distinct type.

Regardless of how the length is determined, the inline length of the LOB cannot be greater than its maximum length.

period-definition

PERIOD FOR

Defines a period for the table. *begin-column-name* must not be the same as *end-column-name*. The data type, length, precision, and scale for *begin-column-name* must be the same as for *end-column-name*.

If `IN ACCELERATOR` is specified, `PERIOD` must not be specified.

SYSTEM_TIME (*begin-column-name*, *end-column-name*)

Defines a system period with the name `SYSTEM_TIME`. There must not be a column in the table with the name `SYSTEM_TIME`. A table can have only one `SYSTEM_TIME` period. *begin-column-name* must be defined as `AS ROW BEGIN` and *end-column-name* must be defined as `AS ROW END`.

BUSINESS_TIME (*begin-column-name*, *end-column-name*)

Defines an application period with the name `BUSINESS_TIME`. There must not be a column in the table with the name `BUSINESS_TIME`. A table can have only one `BUSINESS_TIME` period. *begin-column-name* and *end-column-name* must be defined as `DATE` or `TIMESTAMP(6) WITHOUT TIME ZONE`, and the columns must be defined as `NOT NULL`. *begin-column-name* and *end-column-name* must not identify a column that is defined with a `GENERATED` clause.

An implicit check constraint is generated to ensure the relationship of the value of *end-column-name* to the value of *begin-column-name* as follows:

- For an inclusive-exclusive `BUSINESS_TIME` period, the value of *end-column-name* is greater than the value of *begin-column-name*.
- For an inclusive-inclusive `BUSINESS_TIME` period, the value of *end-column-name* is greater than or equal to the value of *begin-column-name*.

The name of the implicitly created check constraint is `DB2_GENERATED_CHECK_CONSTRAINT_FOR_BUSINESS_TIME`, and that name must not be defined as the name of an existing check constraint.

begin-column-name

Identifies the column that records the beginning of the period of time in which a row is valid. The name must identify a column that exists in the table and must not be the same as a column that is used in the definition of another period for the table. *begin-column-name* must not be the same as *end-column-name*. The data type and precision for *begin-column-name* must be the same as for *end-column-name*.

For a `SYSTEM_TIME` period, *begin-column-name* must be defined as `AS ROW BEGIN`.

For a `BUSINESS_TIME` period, the column must not be defined with a `GENERATED` clause.

end-column-name

Identifies the column that records the end of the period of time in which a row is valid. In the history table that is associated with a system-period temporal table, the history table column that corresponds to *end-column-name* in the system-period temporal table is set to reflect the deletion of the row. The name must identify a column that exists in the table and must not be the same as a column that is used in the definition of another period for the table.

For a `SYSTEM_TIME` period, *end-column-name* must be defined as `AS ROW END`.

For a `BUSINESS_TIME` period, the column must not be defined with a `GENERATED` clause.

EXCLUSIVE

Specifies that the value of the end column is not included in the period. The `BUSINESS_TIME` period is defined as inclusive-exclusive.

INCLUSIVE

Specifies that the value of the end column is included in the period. The BUSINESS_TIME period is defined as inclusive-inclusive.

unique-constraint

CONSTRAINT *constraint-name*

Names the constraint. If a constraint name is not specified, a unique constraint name is generated. If a name is specified, it must be different from the names of any referential, check, primary key, or unique key constraints previously specified on the table.

PRIMARY KEY(*column-name*,...)

Defines a primary key composed of the identified columns. The clause must not be specified more than one time and the same column must not be identified more than one time. The identified columns must be defined as NOT NULL. Each *column-name* must be an unqualified name that identifies a column of the table except for the following types of columns:

- a LOB column
- a ROWID column
- a distinct type column that is based on a LOB or ROWID data type
- an XML column
- a row change timestamp column
- a column in an accelerator-only table

All character and graphic string columns in the key must use the same encoding scheme.

The number of identified columns must not exceed 64. In addition, the sum of the length attributes of the columns must not be greater than $2000 - n - 2m - 3d$, where m is the number of varying-length columns and d is the number of DECFLOAT columns in the key.

The table is marked as unavailable until its primary index is explicitly created unless the table space is explicitly created and the CREATE TABLE statement is processed by the schema processor, or the table space is implicitly created. In that case, Db2 implicitly creates an index to enforce the uniqueness of the primary key and the table definition is considered complete. (For more information about implicitly created indexes, see [Implicitly created indexes](#).)

BUSINESS_TIME WITHOUT OVERLAPS can be specified as the last item in the list. If BUSINESS_TIME WITHOUT OVERLAPS is specified, the list must include at least one *column-name* or *key-expression*. When WITHOUT OVERLAPS is specified, the values for the rest of the specified keys are unique with respect to the time for the BUSINESS_TIME period. When BUSINESS_TIME WITHOUT OVERLAPS is specified, the columns of the BUSINESS_TIME period must not be specified as part of the constraint. The specification of BUSINESS_TIME WITHOUT OVERLAPS adds the following to the constraint:

- The end column of the BUSINESS_TIME period in ascending order
- The begin column of the BUSINESS_TIME period in ascending order

UNIQUE(*column-name*,...)

Defines a unique key composed of the identified columns. Each *column-name* must be an unqualified name that identifies a column of the table. Each identified column must be defined as NOT NULL. The same column must not be identified more than one time. The following types of columns cannot be identified:

- a LOB column
- a ROWID column
- a distinct type column that is based on a LOB or ROWID data type
- an XML column
- a row change timestamp column
- a column in an accelerator-only table

The number of identified columns must not exceed 64. In addition, the sum of the length attributes of the columns must not be greater than $2000 - n - 2m - 3d$, where m is the number of varying-length columns and d is the number of DECFLOAT columns in the key.

All character and graphic string columns in the key must use the same encoding scheme.

A unique key is a duplicate if it is the same as the primary key or a previously defined unique key. The specification of a duplicate unique key is ignored with a warning.

The table is marked as unavailable until all the required indexes are explicitly created unless the table space is explicitly created and the CREATE TABLE statement is processed by the schema processor, or the table space is implicitly created. In these cases, Db2 implicitly creates the indexes that are required for the unique keys and the table definition is considered complete. (For more information about implicitly created indexes, see [Implicitly created indexes](#).)

BUSINESS_TIME WITHOUT OVERLAPS can be specified as the last item in the list. If BUSINESS_TIME WITHOUT OVERLAPS is specified, the list must include at least one *column-name* or *key-expression*. When WITHOUT OVERLAPS is specified, the values for the rest of the specified keys are unique with respect to the time for the BUSINESS_TIME period. When BUSINESS_TIME WITHOUT OVERLAPS is specified, the columns of the BUSINESS_TIME period must not be specified as part of the constraint. The specification of BUSINESS_TIME WITHOUT OVERLAPS adds the following to the constraint:

- The end column of the BUSINESS_TIME period in ascending order
- The begin column of the BUSINESS_TIME period in ascending order

referential-constraint

CONSTRAINT *constraint-name*

Names the referential constraint. If a constraint name is not specified, a unique constraint name is generated. If a name is specified, it must be different from the names of any referential, check, primary key, or unique key constraints previously specified on the table.

FOREIGN KEY (*column-name,...*) **references-clause**

Each specification of the FOREIGN KEY clause defines a referential constraint. The table being created is the child table for the referential constraint.

The foreign key of the referential constraint is composed of the identified columns, and the columns of the BUSINESS_TIME period if the clause PERIOD BUSINESS_TIME is specified. Each *column-name* must be an unqualified name that identifies a column of the table. The same column must not be identified more than one time. If PERIOD BUSINESS_TIME is specified, the columns of the BUSINESS_TIME period must not be specified as part of the constraint. The column cannot be any of the following types of columns:

- a LOB column
- a ROWID column
- a DECFLOAT column
- an XML column
- a row change timestamp column
- a security label column
- a column in an accelerator-only table

The number of identified columns, and the columns of the BUSINESS_TIME period if the clause PERIOD BUSINESS_TIME is specified, must not exceed 64, including columns of the BUSINESS_TIME period if PERIOD BUSINESS_TIME is specified. The sum of the column length attributes must not exceed 255 minus the number of columns that allow null values. The referential constraint is a duplicate if the FOREIGN KEY and parent table are the same as the FOREIGN KEY and parent table of a previously defined referential constraint. The specification of a duplicate referential constraint is ignored with a warning. An exception is that a duplicate referential constraint is not allowed if the definition of the constraint includes the PERIOD BUSINESS_TIME clause.

REFERENCES *parent-table-name (column-name,...)*

The table name that is specified after REFERENCES is the parent table for the referential constraint. *parent-table-name* must identify a table that exists at the current server³³. The table name must not identify one of the following tables:

- A catalog table
- A directory table
- A declared global temporary table
- A history table
- An archive table

In the following discussion, let T2 denote an identified table and let T1 denote the table that you are creating (T1 and T2 cannot be the same table³³).

T2 must have a unique index. The privilege set must include the ALTER or REFERENCES privilege on the parent table, or the REFERENCES privilege on the columns of the nominated parent key, including the columns of the BUSINESS_TIME period if the PERIOD BUSINESS_TIME clause is specified..

The parent key of the referential constraint is composed of the identified columns, or columns of the BUSINESS_TIME period if PERIOD BUSINESS_TIME is specified. Each *column-name* must be an unqualified name that identifies a column of T2. The same column must not be identified more than one time. If PERIOD BUSINESS_TIME is specified, the columns of the BUSINESS_TIME period must not be specified as part of the constraint. The identified column cannot be any of the following types of columns:

- a LOB column
- a ROWID column
- a DECFLOAT column
- an XML column
- a row change timestamp column
- a security label column

The list of column names in the parent key must match the list of column names in a primary key or unique key in the parent table T2. The column names must be specified in the same order as in the primary key or unique key. If PERIOD BUSINESS_TIME was specified for the primary key or unique key of the parent table T2, then PERIOD BUSINESS_TIME must also be specified for the foreign key clause for T1. If any of the referenced columns in T2 has a non-numeric data type, T2 and T1 must use the same encoding scheme, unless T2 is a Unicode table, and T1 is an EBCDIC table with Unicode key columns. In that case, for each character or graphic string column in T1, the CCSID must be the same as the corresponding column in T2.

If a list of column names is not specified, T2 must have a primary key. Omission of a list of column names is an implicit specification of the columns of the primary key for T2.

The specified foreign key must have the same number of columns as the parent key of T2 and, except for their names, default values, null attributes and check constraints, the description of the *n*th column of the foreign key must be identical to the description of the *n*th column of the nominated parent key. If the foreign key includes a column defined as a distinct type, the corresponding column of the nominated parent key must be the same distinct type. If a column of the foreign key has a field procedure, the corresponding column of the nominated parent key must have the same field procedure and an identical field description. A *field description* is a description of the encoded value as it is stored in the database for a column that has been defined to have an associated field procedure.

If PERIOD BUSINESS_TIME is specified in the FOREIGN KEY clause, then PERIOD BUSINESS_TIME must also be specified in the REFERENCES clause. If PERIOD BUSINESS_TIME is not specified in the

³³ This restriction is relaxed when the statement is processed by the schema processor and the other table is created within the same CREATE SCHEMA.

FOREIGN KEY clause, then PERIOD BUSINESS_TIME must also not be specified in the REFERENCES clause.

If the PERIOD BUSINESS_TIME clause is specified, T2 must not be defined as part of a referential cycle. T1 and T2 must not be the same table, and T1 must not be a descendent, directly or indirectly, of another table that is a descendent of T2.

The table space that contains T1 must be available to Db2. If T1 is populated, its table space is placed in a check pending status. A table in a segmented table space is populated if the table is not empty. A table in a table space that is not segmented is considered populated if the table space has ever contained any records.

The referential constraint that is specified by a FOREIGN KEY clause defines a relationship in which T2 is the parent and T1 is the dependent. A description of the referential constraint is recorded in the catalog.

PERIOD BUSINESS_TIME

Specifies that the BUSINESS_TIME period is considered part of the referential constraint. When PERIOD BUSINESS_TIME is specified, the values for the rest of the specified columns are unique with respect to the specified point of time.

PERIOD BUSINESS_TIME can be specified as the last key expression. If PERIOD BUSINESS_TIME is not the last key expression, an error is returned. If PERIOD BUSINESS_TIME is specified, the columns of the BUSINESS_TIME period must not be specified as part of the constraint.

When PERIOD BUSINESS_TIME is specified, the following columns are implicitly added to the end of the constraint:

- The end column of the BUSINESS_TIME period.
- The start column of the BUSINESS_TIME period.

The PERIOD BUSINESS_TIME clause specifies that there must not be a row in the child table for which the period of time represented by the BUSINESS_TIME period values for that row is not contained in the BUSINESS_TIME period of a corresponding row in the parent table. Furthermore, it is not necessary that there be exactly one corresponding row in the parent table where the BUSINESS_TIME period contains the BUSINESS_TIME period of the child row. As long as the BUSINESS_TIME period of a row in the child table is contained in the union of the BUSINESS_TIME periods of two or more contiguous matching rows in the parent table, the referential constraint is considered satisfied.

When the FOREIGN KEY clause specifies the PERIOD BUSINESS_TIME clause, the following conditions apply:

- The corresponding REFERENCES clause must also specify the PERIOD BUSINESS_TIME clause.
- A unique index with the BUSINESS_TIME WITHOUT OVERLAPS clause must be defined on the table. The table is marked as unavailable until the index is created.
- A unique index must be defined on the parent table with the BUSINESS_TIME WITHOUT OVERLAPS clause.

ON DELETE RESTRICT must be, implicitly or explicitly, specified when PERIOD BUSINESS_TIME is also specified.

ON DELETE

The delete rule of the relationship is determined by the ON DELETE clause. For more on the concepts used here, see [Referential constraints \(Introduction to Db2 for z/OS\)](#).

SET NULL must not be specified unless some column of the foreign key allows null values. The default value for the rule depends on the value of the CURRENT RULES special register when the CREATE TABLE statement is processed. If the value of the register is 'Db2', the delete rule defaults to RESTRICT; if the value is 'STD', the delete rule defaults to NO ACTION.

The delete rule applies when a row of T2 is the object of a DELETE or propagated delete operation and that row has dependents in T1. Let p denote such a row of T2. Then:

- If RESTRICT or NO ACTION is specified, an error occurs and no rows are deleted.

- If CASCADE is specified, the delete operation is propagated to the dependents of *p* in T1.
- If SET NULL is specified, each nullable column of the foreign key of each dependent of *p* in T1 is set to null.

Let T3 denote a table identified in another FOREIGN KEY clause (if any) of the CREATE TABLE statement. The delete rules of the relationships involving T2 and T3 must be the same and must not be SET NULL if:

- T2 and T3 are the same table.
- T2 is a descendent of T3 and the deletion of rows from T3 cascades to T2.
- T2 and T3 are both descendents of the same table and the deletion of rows from that table cascades to both T2 and T3.

ENFORCED or NOT ENFORCED

Indicates whether or not the referential constraint is enforced by Db2 during normal operations, such as insert, update, or delete.

ENFORCED

Specifies that the referential constraint is enforced by the Db2 during normal operations (such as insert, update, or delete) and that it is guaranteed to be correct. This is the default.

NOT ENFORCED

Specifies that the referential constraint is not enforced by Db2 during normal operations, such as insert, update, or delete. This option should only be used when the data that is stored in the table is verified to conform to the constraint by some other method than relying on the database manager.

ENABLE QUERY OPTIMIZATION

Specifies that the constraint can be used for query optimization. Db2 uses the information in query optimization using materialized query tables with the assumption that the constraint is correct. This is the default.

check-constraint

CONSTRAINT *constraint-name*

Names the check constraint. The constraint name must be different from the names of any referential, check, primary key, or unique key constraints previously specified on the table.

If *constraint-name* is not specified, a unique constraint name is derived from the name of the first column in the *check-condition* specified in the definition of the check constraint.

CHECK (*check-condition*)

Defines a check constraint. At any time, the *check-condition* must be true or unknown for every row of the table. A *check-condition* can evaluate to unknown if a column that is an operand of the predicate is null. A *check-condition* that evaluates to unknown does not violate the check constraint. A *check-condition* is a search condition, with the following restrictions:

- It can refer only to columns of table *table-name*.
- The columns cannot be the following types of columns:
 - LOB columns
 - ROWID columns
 - DECFLOAT columns
 - distinct type columns that are based on LOB, ROWID, and DECFLOAT data types
 - XML columns
 - security label columns
 - columns in an accelerator-only table
- It can be up to 3800 bytes long, not including redundant blanks.
- It must not contain any of the following:

- Subselects
 - Built-in or user-defined functions
 - CAST specifications
 - Cast functions other than those created when the distinct type was created
 - Host variables
 - Parameter markers
 - Special registers
 - Global variables
 - Columns that include a field procedure
 - CASE expressions
 - ROW CHANGE expressions
 - Row-value expressions
 - DISTINCT predicates
 - GX constants (hexadecimal graphic string constants)
 - Sequence references
 - OLAP specifications
- It must not result in CCSID conversion.
 - If a *check-condition* refers to a LOB column (including a distinct type that is based on a LOB), the reference must occur within a LIKE predicate.
 - The AND and OR logical operators can be used between predicates. The NOT logical operator cannot be used with the following predicates: NOT BETWEEN, NOT IN, NOT LIKE, or IS NOT NULL.
 - The first operand of every predicate must be the column name of a column in the table.
 - The second operand in the *check-condition* must be either a constant or the name of a column in the table.
 - If the second operand of a predicate is a constant, and if the constant is:
 - A floating-point number, then the column data type must be floating point.
 - A decimal number, then the column data type must be either floating point or decimal.
 - An integer number, then the column data type must not be a small integer.
 - A small integer number, then the column data type must be small integer.
 - A decimal constant, then its precision must not be larger than the precision of the column.
 - If the second operand of a predicate is a column, then both columns of the predicate must have:
 - The same data type.
 - Identical descriptions with the exception that the specification of the NOT NULL and DEFAULT clauses for the columns can be different, and that string columns with the same data type can have different length attributes.

LIKE

table-name or view-name

Specifies that the columns of the table have exactly the same name and description as the columns of the identified table or view.

The name that is specified after LIKE must identify a table or view that exists at the current server or a declared temporary table. A view cannot contain columns of length 0.

LIKE must not reference an accelerator-only table or be used with the IN ACCELERATOR clause.

The privilege set must implicitly or explicitly include the SELECT privilege on the identified table or view. If the identified table or view contains a column with a distinct type, the USAGE privilege on

the distinct type is also needed. An identified table must not be an auxiliary table or a clone table. An identified view must not include a column that is an explicitly defined ROWID column (including a distinct type that is based on a ROWID), an identity column, or a row change timestamp column.

The use of LIKE is an implicit definition of n columns, where n is the number of columns in the identified table (including implicitly hidden columns) or view. A column of the new table that corresponds to an implicitly hidden column in the existing table will also be defined as implicitly hidden. The implicit definition includes all attributes of the n columns as they are described in SYSCOLUMNS with the following exceptions:

- When a table is identified in the LIKE clause and a column in the table has a field procedure, the corresponding column of the new table has the same field procedure and the field description. However, the field procedure is not invoked during the execution of the CREATE TABLE statement. When a view is identified in the LIKE clause, none of the columns of the new table will have a field procedure. This is true even in the case that a column of a base table underlying the view has a field procedure defined.
- When a table is identified in the LIKE clause and a column in the table is an identity column, the corresponding column of the new table inherits only the data type of the identity column; none of the identity attributes of the column are inherited unless the INCLUDING IDENTITY clause is specified.
- When a table is identified in the LIKE clause and a column in the table is a security label column, the corresponding column of the new table inherits only the data type of the security label column; none of the security label attributes of the column are inherited.
- When a table that contains a ROWID column is identified in the LIKE clause, the corresponding column of the new table inherits the ROWID column, regardless of whether the column has the IMPLICITLY HIDDEN attribute.
- When a table is identified in the LIKE clause and the table contains a row change timestamp column, a transaction-start-ID column, a row-begin column, or a row-end column, the corresponding column of the new table inherits only the data type of the original column. The new column is not considered a generated column.
- When a table is identified in the LIKE clause and a column in the table is a generated expression column, the corresponding column of the new table inherits only the data type of the original column. The new column is not considered a generated column.
- When a table is identified in the LIKE clause and the table contains an inline LOB column, the corresponding columns of the new table will inherit the inline attribute if the table is in an universal table space. Otherwise, the inline attribute of the table identified in the LIKE clause is ignored.
- When a view is identified in the LIKE clause, the default value that is associated with the corresponding column of the new table depends on the column of the underlying base table for the view. If the column of the base table does not have a default, the new column does not have a default. If the column of the base table has a default, the default of the new column is:
 - Null if the column of the underlying base table allows nulls.
 - The default for the data type of the underlying base table if the underlying base table does not allow nulls.

The above defaults are chosen regardless of the current default of the base table column. The existence of an INSTEAD OF trigger does not affect the inheritance of default values.

- When a table that uses table-controlled partitioning is identified in the LIKE clause, the new table does not inherit partitioning scheme of that table. You can add these partition boundaries by specifying ALTER TABLE with the ADD PARTITION BY RANGE clause.
- The CCSID of the column is determined by the implicit or explicit CCSID clause. For more information, see the CCSID clause.

An exception is a Unicode column in an EBCDIC table, which inherits the CCSID of the column in the existing table.

- When a table is identified in the LIKE clause and the table includes a period definition, the new table does not inherit the period definition.
- When the table that is identified in the LIKE clause is a system-period temporal table, the new table is not a system-period temporal table.
- When the table that is identified in the LIKE clause has row access controls or column access controls activated, the new table does not inherit the row access controls or the column access controls.

The implicit definition does not include any other attributes of the identified table or view. For example, the new table does not have a primary key or foreign key. The table is created in the table space implicitly or explicitly specified by the IN clause, and the table has any other optional clause only if the optional clause is specified.

copy-options

copy-options

Specifies whether identity column attributes, row change timestamp attributes, and column defaults are inherited from the definition of the source of the result table.

EXCLUDING IDENTITY COLUMN ATTRIBUTES or INCLUDING IDENTITY COLUMN ATTRIBUTES

Specifies whether identity column attributes are inherited from the definition of the source of the result table.

EXCLUDING IDENTITY COLUMN ATTRIBUTES

Specifies that identity column attributes are not inherited from the definition of the source of the result table. This is the default.

INCLUDING IDENTITY COLUMN ATTRIBUTES

Specifies that, if available, identity column attributes (such as START WITH, INCREMENT BY, and CACHE values) are inherited from the definition of the source table. These attributes can be inherited if the element of the corresponding column in the table, view, or *fullselect* is the name of a column of a table or the name of a column of a view that directly or indirectly maps to the column name of a base table with the identity attribute. In other cases, the columns of the new temporary table do not inherit the identity attributes. The columns of the new table do not inherit the identity attributes in the following cases:

- The select list of the *fullselect* includes multiple instances of an identity column name (that is, selecting the same column more than one time).
- The select list of the *fullselect* includes multiple identity columns (that is, it involves a join).
- The identity column is included in an expression in the select list.
- The *fullselect* includes a set operation.

EXCLUDING ROW CHANGE TIMESTAMP COLUMN ATTRIBUTES or INCLUDING ROW CHANGE TIMESTAMP COLUMN ATTRIBUTES

Specifies whether row change timestamp column attributes are inherited from the definition of the source of the result table.

EXCLUDING ROW CHANGE TIMESTAMP COLUMN ATTRIBUTES

Specifies that row change timestamp column attributes are not inherited from the source result table definition. This is the default.

INCLUDING ROW CHANGE TIMESTAMP COLUMN ATTRIBUTES

Specifies that, if available, row change timestamp column attributes are inherited from the definition of the source table. These attributes can be inherited if the element of the corresponding column in the table, view, or *fullselect* is the name of a column of a table or the name of a column of a view that directly or indirectly maps to the column name of a base table defined as a row change timestamp column. In other cases, the columns of the new temporary table do not inherit the row change timestamp column attributes. The columns of the new table do not inherit the row change timestamp attributes in the following cases:

- The select list of the *fullselect* includes multiple instances of a row change timestamp column name (that is, selecting the same column more than one time).
- The select list of the *fullselect* includes multiple row change timestamp column names (that is, it involves a join).
- The row change timestamp column is included in an expression in the select list.
- The *fullselect* includes a set operation (such as union).

EXCLUDING COLUMN DEFAULTS, INCLUDING COLUMN DEFAULTS, or USING TYPE DEFAULTS

Specifies whether column defaults are inherited from the source result table definition. EXCLUDING COLUMN DEFAULTS, INCLUDING COLUMN DEFAULTS, and USING TYPE DEFAULTS must not be specified if the LIKE clause is specified.

EXCLUDING COLUMN DEFAULTS

Specifies that the column defaults are not inherited from the definition of the source table. The default values of the column of the new table are either null or there are no default values. If the column can be null, the default is the null value. If the column cannot be null, there is no default value, and an error occurs if a value is not provided for a column on an insert or update operation, or LOAD for the new table.

INCLUDING COLUMN DEFAULTS

Specifies that column defaults for each updatable column of the definition of the source table are inherited. Columns that are not updatable do not have a default defined in the corresponding column of the created table. The existence of an INSTEAD OF trigger for a view does not affect the inheritance of default values.

USING TYPE DEFAULTS

Specifies that the default values for the table depend on data type of the columns that result from *fullselect*, as follows:

Data type

Default value

Numeric

0

Fixed-length character string

Blanks

Fixed-length graphic string

Blanks

Fixed-length binary string

Hexadecimal zeros

Varying-length string

A string of length 0

Fixed-length char or fixed-length graphic

A string of blanks

Fixed-length binary

Hexadecimal zeros

Date

CURRENT DATE

Time

CURRENT TIME

Timestamp(*integer*) without time zone

CURRENT TIMESTAMP(*p*) WITHOUT TIME ZONE where *p* is the corresponding timestamp precision.

Timestamp(*integer*) with time zone

CURRENT TIMESTAMP(*p*) WITH TIME ZONE where *p* is the corresponding timestamp precision.

as-result-table

as-result-table

Specifies that the column definitions of the table are based on the result of the *fullselect*.

column-name

Names the columns in the table. If a list of column names is specified, it must consist of as many names as there are columns in the result table of the *fullselect*. Each *column-name* must be unique and unqualified. If a list of column names is not specified, the columns of the table inherit the names of the columns of the result table of the *fullselect*.

A list of column names must be specified if the result table of the *fullselect* has duplicate column names or an unnamed column. An unnamed column is a column derived from a constant, function, expression, or set operation that is not named using the AS clause.

AS (*fullselect*)

Specifies that the table definition is based on the column definitions from the result of the *fullselect*. The use of AS (*fullselect*) is an implicit definition of *n* columns for the table, where *n* is the number of columns that would result from the *fullselect*. The columns of the new table are defined by the columns that result from the *fullselect*. Every select list element must have a unique name. The AS clause can be used in the *select-clause* to provide unique names.

The implicit definition includes the column name, data type, length, precision, scale, and nullability characteristic of each of the result columns of *fullselect*. The length of each column must not be 0. Other column attributes, such as DEFAULT and IDENTITY, are not inherited from the *fullselect*. A column of the new table that corresponds to an implicitly hidden column of a base table referenced in the *fullselect* is not considered hidden in the new table. The generated column attributes are not inherited from the *fullselect*. That is, a new column of the table is not considered as a generated column. A FIELDPROC is inherited for a column if the corresponding select item of the *fullselect* is a column that can be mapped to a column of a base table or a view. The new table contains a security label column if only one table in the *fullselect* contains a security label column and the primary authorization ID of the statement has a valid security label.

The outermost SELECT list of the *fullselect* must not reference data that is encoded with different encoding schemes. An exception is that the outermost SELECT list can contain a mixture of EBCDIC and Unicode columns. In this case, the new table is an EBCDIC table with one or more Unicode columns.

The implicit definition does not include any other attributes of the identified table or view. For example, the new table does not have a primary key or foreign key. The table is created in the table space implicitly or explicitly specified by the IN clause, and the table has any other optional clause only if the optional clause is specified.

If IN ACCELERATOR is specified, AS (*fullselect*) cannot be specified.

The owner of the table being created must have the SELECT privilege on the tables or views referenced in the *fullselect*, or the privilege set must include SYSADM or DBADM authority for the database in which the tables of the *fullselect* reside. Having SELECT privilege means that the owner has at least one of the following authorizations.

- Ownership of the tables or views referenced in the *fullselect*
- The SELECT privilege on the tables and views referenced in the *fullselect*
- SYSADM authority
- DBADM authority for the database in which the tables of the *fullselect* reside

Additional privileges might be necessary for accessing other objects that are referenced in the *fullselect*.

The *fullselect* must not:

- Result in a column having a ROWID, BLOB, CLOB, DBCLOB, or XML data type or a distinct type based on these data types.
- Include multiple security label columns.

- Include a PREVIOUS VALUE or a NEXT VALUE expression.
- Refer to host variables or include parameter markers.
- Include an SQL data change statement in the FROM clause.
- In the outermost SELECT, reference a combination of ASCII and EBCDIC data, or a combination of ASCII and Unicode data.
- Result in a column that is an array.
- Reference a remote object.
- Reference an accelerator-only table.

WITH NO DATA

Specifies that the query is used only to define the attributes of the new table. The table is not populated using the results of the *fullselect* and the REFRESH TABLE statement cannot be used.

If the tables that are specified in the *fullselect* use row access controls or column access controls, the row access controls and the column access controls are not defined for the new table.

materialized-query-definition

materialized-query-definition

Specifies that the column definitions of the materialized query table are based on the result of a *fullselect*. If *materialized-query-table-options* are specified, the REFRESH TABLE statement can be used to populate the table with the results of the *fullselect*.

column-name

Names the columns in the table. If a list of column names is specified, it must consist of as many names as there are columns in the result table of the *fullselect*. Each *column-name* must be unique and unqualified. If a list of column names is not specified, the columns of the table inherit the names of the columns of the result table of the *fullselect*.

A list of column names must be specified if the result table of the *fullselect* has duplicate column names or an unnamed column. An unnamed column is a column derived from a constant, function, expression, or set operation that is not named using the AS clause of the select list.

AS (*fullselect*)

Specifies that the table definition is based on the column definitions from the result of the *fullselect*. The use of AS (*fullselect*) is an implicit definition of *n* columns for the table, where *n* is the number of columns that would result from the *fullselect*. The columns of the new table are defined by the columns that result from the *fullselect*. Every select list element must have a unique name. The AS clause can be used in the *select-clause* to provide unique names.

The implicit definition includes the column name, data type, length, precision, scale, and nullability characteristic of each of the result columns of *fullselect*. The length of each column must not be a 0. Other column attributes, such as DEFAULT, IDENTITY, and unique constraints, are not inherited from the *fullselect*. A column of the new table that corresponds to an implicitly hidden column of a base table referenced in the *fullselect* is not considered hidden in the new table. The generated column attributes are not inherited from the *fullselect*. That is, the new column of the materialized query table is not considered as a generated column. A FIELDPROC is inherited for a column if the corresponding select item of the *fullselect* is a column that can be directly mapped to a column of a base table or a view in the FROM clause of the *fullselect*. The materialized query table contains a security label column if only one table in the *fullselect* contains a security label column and the primary authorization ID of the statement has a valid security label.

The outermost SELECT list of the *fullselect* can include result columns that are defined as EBCDIC columns and result columns that are defined as Unicode columns. In this case, the materialized query table is an EBCDIC table with one or more Unicode columns.

Authorization for creating materialized query tables

The owner of the table being created must have the SELECT privilege on the tables or views referenced in the *fullselect*, or the privilege set must include SYSADM or DBADM authority for

the database in which the tables of the fullselect reside. Having SELECT privilege means that the owner has at least one of the following authorizations:

- Ownership of the tables or views referenced in the fullselect
- The SELECT privilege on the tables and views referenced in the fullselect
- SYSADM authority
- DBADM authority for the database in which the tables of the fullselect reside

Additional privileges might be necessary for accessing other objects that are referenced in the fullselect.

The rules for establishing the qualifiers for names used in the fullselect are the same as the rules used to establish the qualifiers for *table-name*.

The following restrictions apply when creating materialized query tables. When *fullselect* does not satisfy the restrictions, an error occurs:

- The length of each result column of the fullselect must not be 0.
- The fullselect cannot contain a column of a LOB or XML data type.
- No more than one table in the fullselect can contain a security label column.
- The fullselect must not contain a period specification.
- The outermost SELECT list must not reference data that is encoded with a combination of ASCII and EBCDIC CCSID sets, or a combination of ASCII and Unicode CCSID sets.
- The object that is specified in the FROM clause of the fullselect cannot be a view with columns of length 0.
- The fullselect cannot contain a reference to a created global temporary table, a declared global temporary table, an accelerator-only table, a directory table, or another materialized query table.
- If IN ACCELERATOR is specified, *materialized-query-definition* cannot be specified.
- The fullselect cannot directly or indirectly reference a base table that has been activated for the row or column access control or a base table for which a row permission or a column mask has been defined.
- The fullselect must not refer to host variables or include parameter markers.
- The fullselect must not refer to global variables.
- The fullselect must not include the following built-in functions: LISTAGG, PERCENTILE_CONT, or PERCENTILE_DISC.

Additional restrictions when ENABLE QUERY OPTIMIZATION is in effect:

- The fullselect must be a subselect.
- The subselect cannot include the following:
 - A special register
 - A scalar fullselect
 - A row change timestamp column
 - A ROW CHANGE expression
 - An expression for which implicit time zone values apply (for example, cast a timestamp to a timestamp with time zone)
 - The RAND built-in function
 - The RID built-in function
 - A user-defined scalar or table function that is not deterministic or that has external actions
 - Any predicates that include a subquery
 - A *row-value-expression* in a predicate

- A join using the INNER JOIN syntax, or an outer join
- A lateral correlation
- A nested table expression or view that requires temporary materialization
- A direct or indirect reference to a table that uses activated row or column access controls, or a table for which row or column access controls have been defined.
- A FETCH FIRST clause
- A reference to a global variable
- A collection-derived table (UNNEST)
- A GROUPING SETS or *super-groups* clause
- If a table with a security label is referenced, the security label column must be referenced in the outer select list of the subselect.
- If the subselect references a view, the fullselect in the view definition must satisfy all other restrictions.

refreshable-table-options

Specifies the options for a refreshable materialized query table. The ORDER BY clause is allowed, but it is used only by REFRESH. The ORDER BY clause can improve the locality of reference of data in the materialized query table.

DATA INITIALLY DEFERRED

Specifies that the data is not inserted into the materialized query table when it is created. Use the REFRESH TABLE statement to populate the materialized query table, or use the INSERT statement to insert data into a user-maintained materialized query table.

REFRESH DEFERRED

Specifies that the data in the table can be refreshed at any time using the REFRESH TABLE statement. The data in the table only reflects the result of the query as a snapshot at the time when the REFRESH TABLE statement is processed or when it was last updated for a user-maintained materialized query table.

MAINTAINED BY SYSTEM or MAINTAINED BY USER

Specifies how the data in the materialized query table is maintained.

MAINTAINED BY SYSTEM

Specifies that the materialized query table is maintained by the system. Only the REFRESH statement is allowed on the table. This is the default.

MAINTAINED BY USER

Specifies that the materialized query table is maintained by the user, who can use the LOAD utility, an SQL data change statement, a SELECT from data change statement, or REFRESH TABLE SQL statements on the table.

ENABLE QUERY OPTIMIZATION or DISABLE QUERY OPTIMIZATION

Specifies whether this materialized query table can be used for optimization.

ENABLE QUERY OPTIMIZATION

Specifies that the materialized query table can be used for query optimization. If the fullselect specified does not satisfy the restrictions for query optimization, an error occurs.

ENABLE QUERY OPTIMIZATION is the default.

The fullselect must not contain a period specification.

DISABLE QUERY OPTIMIZATION

Specifies that the materialized query table cannot be used for query optimization. The table can still be queried directly.

IN

IN *database-name.table-space-name* or IN DATABASE *database-name*

Identifies the database and table space in which the table is created. Both forms are optional.

If you specify *database-name* and *table-space-name*, the database must be described in the catalog on the current server. The database must not be DSNDB06 or a work file database. The table space must belong to the database that you specify.

If you specify *database-name* but not *table-space-name*, a table space is implicitly created in *database-name*. The name of the table space is derived from the name of the table. The buffer pool that is used is the default buffer pool for user data that is specified on installation panel DSN TIP1.

If you specify a table space but not a database, the database that contains the table space is used.

If you do not specify the IN clause, a database is implicitly created with the name DSNxxxxx, where xxxxx is a five-digit number. A table space is also implicitly created.

If you specify *table-space-name*, the table space cannot be one of the following table spaces:

- A table space that was created implicitly
- A partitioned table space that already contains a table
- A LOB table space
- An XML table space
- [FL 504](#) A non-UTS table space

If you specify a partitioned table space, you cannot load or use the table until its partitioned scheme is created.

You cannot specify a name in the format of an implicitly created database name, which is DSNxxxxx, where xxxxx is a five-digit number..

If you specify *table-space-name*, but you do not specify *database-name*, or you do not specify the IN clause, users who have the authority to create table spaces or tables in database DSNDB04 have authority to create tables and table spaces in the implicitly created database.

If you do not specify *table-space-name*, the privilege set must have: SYSADM or SYSCTRL authority; DBADM, DBCTRL, or DBMAINT authority for the database; or the CREATETS privilege for the database. You must also have the USE privilege for the default buffer pool in the database and default storage group.

For implicitly created table spaces, Db2 selects the buffer pool as described in [Implicitly defined table spaces \(Db2 Administration Guide\)](#).

IN ACCELERATOR *accelerator-name*

Specifies that the table is an accelerator-only table. *accelerator-name* identifies the accelerator in which the table will be defined.

[FL 509](#) You can specify an alias (logical name) for *accelerator-name*. For more information, see [Using an alias for an accelerator \(Db2 Performance\)](#). To create a high availability accelerator-only table, specify a location alias that represents multiple accelerators to define the table in all accelerators that are associated with the location alias.

If you specify an accelerator-only table, the table and the data of the table exists only in the accelerator, not in Db2. However, the table and column definition of the accelerator-only table are contained in Db2 catalog tables.

partitioning-clause block

PARTITION BY SIZE or PARTITION BY RANGE

Specifies the partitioning scheme for the table. For more information, see [Partitioning data in Db2 tables \(Db2 Administration Guide\)](#).

PARTITION BY SIZE

Specifies that the table is created in a partition-by-growth table space. If the IN clause specifies a *table-space-name*, it must identify a partition-by-growth table space. If the IN clause does not specify an existing table space name and the PARTITION BY clause is not specified, PARTITION BY SIZE is the default.

If IN ACCELERATOR is specified, PARTITION BY SIZE must not be specified.

EVERY *integer* G

Specifies that the table is to be partitioned by growth, every *integer* G bytes. *integer* must not be greater than 256. If the IN clause identifies a table space, *integer* must be the same as the DSSIZE value that is in effect for the table space that will contain the table.

integer can be separated from G by 0 or more spaces.

PARTITION BY RANGE

Specifies the range partitioning scheme for the table (the columns that are used to partition the data). When this clause is specified, the table space is complete, and it is not necessary to create a partitioned index on the table. If this clause is used, the ENDING AT clause cannot be used on a subsequent CREATE INDEX statement for this table.

PARTITION BY RANGE must not be specified for a table that is created in a partition-by-growth table space. If IN ACCELERATOR is specified, PARTITION BY RANGE must not be specified.

partition-expression

Specifies the key data over which the range is defined to determine the target data partition of the data.

column-name

Specifies the columns of the key. Each *column-name* must identify a column of the table. Do not specify more than 64 columns or the same column more than one time. The sum of length attributes of the columns must not be greater than 255 - *n*, where *n* is the number of columns that can contain null values. Do not specify a qualified column name.

A timestamp with time zone column (or a column with a distinct type that is based on the timestamp with time zone data type) can only be specified as the last column in a partitioning key.

Do not specify a column for *column-name* if the column is defined as follows:

- a LOB column (or a column with a distinct type that is based on a LOB data type)
- a BINARY column (or a column with a distinct type that is based on a BINARY data type)
- a VARBINARY column (or a column with a distinct type that is based on a VARBINARY data type)
- a DECFLOAT column (or a column with a distinct type that is based on a DECFLOAT data type)
- an XML column

All character and graphic string columns in the key must be defined with the same encoding scheme.

NULLS LAST

Specifies that null values are treated as positive infinity for purposes of comparison.

ASC

Puts the entries in ascending order by the column. ASC is the default.

DESC

Puts the entries in descending order by the column.

partition-element

Specifies ranges for a data partitioning key and the table space where rows of the table in the range will be stored.

PARTITION *integer*

integer is the physical number of a partition in the table space. A PARTITION clause must be specified for every partition of the table space. In this context, highest means highest in the sorting sequences of the columns. In a column defined as ascending (ASC), highest and lowest have their usual meanings. In a column defined as descending (DESC), the lowest actual value is highest in the sorting sequence.

ENDING AT (*constant*, MAXVALUE, or MINVALUE, ...)

Defines the limit key for a partition boundary. Specify at least one value (*constant*, MAXVALUE, or MINVALUE) after ENDING AT in each PARTITION clause. You can use as many values as there are columns in the key. The concatenation of all values is the highest value of the key for ascending and the lowest for descending.

constant

Specifies a constant value with a data type that must conform to the rules for assigning that value to the column. If a string constant is longer or shorter than required by the length attribute of its column, the constant is either truncated or padded on the right to the required length. If the column is ascending, the padding character is X'FF'. If the column is descending, the padding character is X'00'. The precision and scale of a decimal constant must not be greater than the precision and scale of its corresponding column. A hexadecimal string constant (GX) cannot be specified.

MAXVALUE

Specifies a value greater than the maximum value for the limit key of a partition boundary (that is, all X'FF' regardless of whether the column is ascending or descending). If all of the columns in the partitioning key are ascending, a constant or the MINVALUE clause cannot be specified following MAXVALUE. After MAXVALUE is specified, all subsequent columns must be MAXVALUE.

MINVALUE

Specifies a value that is smaller than the minimum value for the limit key of a partition boundary (that is, all X'00' regardless of whether the column is ascending or descending). If all of the columns in the partitioning key are descending, a constant or the MAXVALUE clause cannot be specified following MINVALUE. After MINVALUE is specified, all subsequent columns must be MINVALUE.

The key values are subject to the following rules:

- The first value corresponds to the first column of the key, the second value to the second column, and so on. Using fewer values than there are columns in the key has the same effect as using the highest or lowest values for the omitted columns, depending on whether they are ascending or descending.
- The highest value of the key in any partition must be lower than the highest value of the key in the next partition for ascending cases.
- The values specified for the last partition are enforced. The value specified for the last partition is the highest value of the key that can be placed in the table. Any key values greater than the value specified for the last partition are out of range.
- If the concatenation of all the values exceeds 255 bytes, only the first 255 bytes are considered.
- If a key includes a ROWID column or a column with a distinct type that is based on a ROWID data type, 17 bytes of the constant that is specified for the corresponding ROWID column are considered.
- If a null value is specified for the partitioning key and the key is ascending, an error is returned unless MAXVALUE is specified. If the key is descending, an error is returned unless MINVALUE is specified.

partition-hash-space

See [partition-hash-space](#).

INCLUSIVE

Specifies that the specified range values are included in the data partition.

organization-clause

See [organization-clause](#).

Other options

EDITPROC *program-name*

Identifies the user-written code that implements the edit procedure for the table. The edit procedure must exist at the current server. The procedure is invoked during the execution of an SQL data change statement or LOAD and all row retrieval operations on the table.

An edit routine receives an entire table row, and can transform that row in any way. Also, it receives a transformed row and must change the row back to its original form.

For information on writing an EDITPROC exit routine, see [Edit procedures \(Db2 Administration Guide\)](#).

WITH ROW ATTRIBUTES

Specifies that the edit procedure parameter list contains an address for the description of a row. WITH ROW ATTRIBUTES must not be specified for a table with an identity, LOB, XML, ROWID, or SECURITY LABEL column. WITH ROW ATTRIBUTES is the default. When WITH ROW ATTRIBUTES is specified, the column names in the table must not be longer than 18 EBCDIC SBCS characters in length.

WITHOUT ROW ATTRIBUTES

Specifies that the description of the row is not provided to the edit procedure. On entry to the edit procedure, the address for the row description in the parameter list contains a value of zero.

VALIDPROC *program-name*

Designates *program-name* as the validation exit routine for the table. Writing a validation exit routine is described in [Validation routines \(Db2 Administration Guide\)](#).

The validation routine can inhibit a load, insert, update, or delete operation on any row of the table: before the operation takes place, the procedure is passed the row. The values that are represented by any LOB or XML columns in the table are not passed to the validation routine. On an insert or update operation, if the table has a security label column and the user does not have write-down privilege, the user's security label value is passed to the validation routine as the value of the column. After examining the row, the procedure returns a value that indicates whether the operation should proceed. A typical use is to impose restrictions on the values that can appear in various columns. If IN ACCELERATOR is specified, VALIDPROC must not be specified.

A table can have only one validation procedure at a time. In an ALTER TABLE statement, you can designate a replacement procedure or discontinue the use of a validation procedure.

If you omit VALIDPROC, the table has no validation routine.

AUDIT

Identifies the types of access to this table that causes auditing to be performed. For information about audit trace classes, see [Types of Db2 traces \(Db2 Performance\)](#) and [-START TRACE command \(Db2\) \(Db2 Commands\)](#).

If a materialized query table is refreshed with the REFRESH TABLE statement, the auditing also occurs during the REFRESH TABLE operation. AUDIT works as usual for LOAD and SQL data change operations on a user-maintained materialized query table.

NONE

Specifies that no auditing is to be done when this table is accessed. This is the default.

CHANGES

Specifies that auditing is to be done when the table is accessed during the first insert, update, or delete operation. However, the auditing is done only if the appropriate audit trace class is active.

ALL

Specifies that auditing is to be done when the table is accessed during the first operation of any kind performed by a utility or application process. However, the auditing is done only if the appropriate audit trace class is active and the access is not performed with COPY, RECOVER, REPAIR, LOAD with a dummy input data set, or any stand-alone utility.

If the table is subsequently altered with an ALTER TABLE statement, the ALTER TABLE statement is audited for successful and failed attempts in the following cases, if the appropriate audit trace class is active:

- AUDIT attribute is changed to NONE, CHANGES, or ALL on an audited or non-audited table.
- AUDIT CHANGES or AUDIT ALL is in effect.

If IN ACCELERATOR is specified, AUDIT NONE, CHANGES, and ALL must not be specified.

OBID integer

Identifies the OBID to be used for this table. An OBID is the identifier for an object's internal descriptor. The integer must be greater than 1 and must not identify an existing or previously used OBID of the database. If you omit OBID, Db2 generates a value.

The following statement retrieves the value of OBID:

```
SELECT OBID
FROM SYSIBM.SYSTABLES
WHERE CREATOR = 'ccc' AND NAME = 'nnn';
```

Here, *nnn* is the table name and *ccc* is the creator of the table.

DATA CAPTURE

Specifies whether the logging of the following actions on the table includes additional information to support data replication processing:

- SQL data change operations
- Adding columns (using the ADD COLUMN clause)
- Changing columns (using the ALTER COLUMN clause)

For more information, see [Altering a table to capture changed data \(Db2 Administration Guide\)](#).

If a materialized query table is refreshed with the REFRESH TABLE statement, the logging of the augmented information occurs during the REFRESH TABLE operation. DATA CAPTURE works as usual for insert, update, and delete operations on a user-maintained materialized query table.

A table with data that is stored only in an accelerator-only table cannot be defined with this attribute.

NONE

Do not record additional information to the log. This is the default.

CHANGES

Write additional data about SQL updates to the log. Information about the values that are represented by any LOB or XML columns is not available. Do not specify DATA CAPTURE CHANGES for tables that reside in table spaces that specify NOT LOGGED.

WITH RESTRICT ON DROP

Indicates that the table can be dropped only by using REPAIR DBD DROP. In addition, the database and table space that contain the table can be dropped only by using REPAIR DBD DROP.

The WITH RESTRICT ON DROP clause can be removed using the ALTER TABLE statement with the DROP RESTRICT ON DROP clause. After the WITH RESTRICT ON DROP clause is removed from the definition of the table, the table, the database, and the containing table space can be dropped using the DROP statement.

CCSID encoding-scheme

Specifies the encoding scheme for string data stored in the table. If the IN clause is specified with a table space, the value must agree with the encoding scheme that is already in use for the specified table space. The specific CCSIDs for SBCS, mixed, and graphic data are determined by the table space or database specified in the IN clause. If the IN clause is not specified, the value specified is used for the table being created as well as for the table space that Db2 implicitly creates. The specific CCSIDs for SBCS, mixed, and graphic data are determined by the default CCSIDs for the server for the specified encoding scheme. The valid values are ASCII, EBCDIC, and UNICODE.

If IN ACCELERATOR is specified, a Unicode column cannot be defined in an EBCDIC table and a column cannot be defined as ASCII mixed or graphic. *IBM Db2 Analytics Accelerator for z/OS: Stored Procedures Reference* contains a complete description of encoding schemes allowed in an accelerator.

If the CCSID clause is not specified, the encoding scheme for the table depends on the IN clause:

- If the IN clause is specified, the encoding scheme already in use for the table space or database specified in the IN clause is used.
- If the IN clause is not specified, the encoding scheme of the new table is the same as the scheme for the table that is specified in the LIKE clause.

If CCSID EBCDIC is explicitly or implicitly specified, and any columns in the table are defined with the CCSID 1208 or CCSID 1200 clause, CCSID EBCDIC represents the default encoding scheme for character or graphic columns that do not include the CCSID 1208 or CCSID 1200 clause.

If the CCSID clause is specified for a materialized query table:

- If the encoding scheme in the CCSID clause is ASCII or Unicode, or if the encoding scheme in the CCSID clause is EBCDIC and the result table of the fullselect contains no Unicode columns, the encoding scheme specified in the clause must be the same as the scheme for the result CCSID of the fullselect. The CCSID must also be the same as the CCSID of the table space for the table being created.
- If the encoding scheme in the CCSID clause is EBCDIC, and the result table of the fullselect contains Unicode columns, the encoding scheme of the table space for the table must be EBCDIC.

VOLATILE or NOT VOLATILE

Specifies how Db2 chooses to access the table.

VOLATILE

Specifies that Db2 uses index access to the table whenever possible for SQL operations. However, be aware that list prefetch and certain other optimization techniques might be disabled when VOLATILE is used.

One instance in which you might want to use VOLATILE is for a table whose size can vary greatly. If statistics are taken when the table is empty or has only a few rows, those statistics might not be appropriate when the table has many rows.

Another instance in which you might want to use VOLATILE is for a table that contains groups of rows, as defined by the primary key on the table. All but the last column of the primary key of such a table indicate the group to which a given row belongs. The last column of the primary key is the sequence number indicating the order in which the rows are to be read from the group. VOLATILE maximizes concurrency of operations on rows within each group, since rows are usually accessed in the same order for each operation. If IN ACCELERATOR is specified, VOLATILE must not be specified. For this usage, the primary index must be the only index that is defined on the table, and list prefetch is disabled to ensure the sequence in which the rows are locked.

NOT VOLATILE

Specifies that SQL access to this table should be based on the current statistics. NOT VOLATILE is the default.

CARDINALITY

An optional keyword that currently has no effect, but that is provided for Db2 family compatibility.

LOGGED or NOT LOGGED

Specifies whether changes that are made to the data in an implicitly created table space are recorded in the log. This parameter applies to an implicitly created table space and to all indexes of this table. XML table spaces and indexes associated with the XML table spaces inherit the logging attribute from the associated base table space. Auxiliary indexes also inherit the logging attribute from the associated base table space.

Do not specify LOGGED or NOT LOGGED if the table space name is specified by using the IN *table-space-name* clause or if the IN ACCELERATOR clause is specified.

LOGGED

Specifies that changes that are made to the data in an implicitly created table space are recorded in the log.

LOGGED is the default.

NOT LOGGED

Specifies that changes that are made to data in an implicitly created table space are not recorded in the log.

NOT LOGGED prevents undo and redo information from being recorded in the log. However, control information for an implicitly created table space will continue to be recorded in the log.

COMPRESS YES or COMPRESS NO

Specifies whether data compression applies to the rows of any implicitly created table space. The IMPTSCMP subsystem parameter specifies the default value. See USE DATA COMPRESSION field (IMPTSCMP subsystem parameter) (Db2 Installation and Migration).

If the IN *table-space-name* clause or the IN ACCELERATOR clause is specified, COMPRESS must not be specified.

YES

FL 509 Specifies that data compression applies to the rows of the implicitly created table space. The rows are not compressed until the LOAD or REORG utility is run on the table in the implicitly created table space, or the total row data size reaches the compression data threshold while an insert operation is performed.

If a keyword for the compression algorithm is not specified, the default compression algorithm is used. The data compression algorithm is determined by the TS_COMPRESSION_TYPE subsystem parameter.

If a keyword for the compression algorithm is specified:

- LOB table spaces that are implicitly created for LOB columns in this table are defined as if COMPRESS YES is specified without a compression algorithm. LOB compression is managed by zEnterprise data compression (zEDC) hardware if available.
- XML table spaces that are implicitly created for XML columns in this table inherit the COMPRESS attribute.

FIXEDLENGTH

FL 509 Specified the fixed-length data compression algorithm.

HUFFMAN

FL 509 Specifies the Huffman data compression algorithm. See Using Huffman compression to compress your data (Db2 Performance) for requirements to enable Huffman compression.

NO

Specifies that data compression is not used for the rows of the implicitly created table space. Inserted and updated rows are not subject to data compression.

APPEND NO or APPEND YES

Specifies whether append processing is used for the table. The APPEND clause must not be specified for a table that is created in a work file table space.

NO

Specifies that append processing is not used for the table. For insert and LOAD operations, Db2 will attempt to place data rows in a well clustered manner with respect to the value in the row's cluster key column.

NO is the default.

YES

Specifies that data rows are to be placed into the table by disregarding the clustering during insert and LOAD operations.

DSSIZE *integer G*

Specifies the maximum size for an implicitly created partition-by-growth or partition-by-range table space. This value is only applied to an implicitly created base table space, not to any associated implicitly created XML or LOB table spaces.

Do not specify DSSIZE *integer G* if any of the following conditions are true:

- The table space name is specified by using the IN *table-space-name* clause.
- The PARTITION BY clause includes the EVERY *integer-constant G* clause.
- The statement contains an accelerator-only table.

The IMPDSSIZE subsystem parameter specifies the default value. See [IMPDSSIZE](#) in macro DSN6SYSP (Db2 Installation and Migration).

For more detailed information about the DSSIZE clause, refer to [“CREATE TABLESPACE statement” on page 1718](#).

integer can be separated from G by 0 or more spaces.

BUFFERPOOL *bpname*

Specifies the buffer pool to use for an implicitly created table space and determines the page size of the table space. For 4KB, 8KB, 16KB and 32KB page buffer pools, the page sizes are 4 KB, 8 KB, 16 KB, and 32 KB, respectively.

bpname must identify an activated buffer pool. The privilege set must include SYSADM authority, SYSCTRL authority, or the USE privilege on the buffer pool.

Do not specify BUFFERPOOL *bpname* if the table space name is specified by using the IN *table-space-name* clause or the IN ACCELERATOR clause is specified.

If you do not specify the BUFFERPOOL clause, Db2 selects the buffer pool as described in [Implicitly defined table spaces \(Db2 Administration Guide\)](#).

Refer to [“Naming conventions in SQL” on page 79](#) for more information about *bpname*.

MEMBER CLUSTER

Specifies that data that is inserted by an insert operation is not clustered by the implicit clustering index (the first index) or the explicit clustering index. Db2 places the data in an implicitly created table space based on available space.

Do not specify MEMBER CLUSTER if the table space name is specified by using the IN *table-space-name* clause or if IN ACCELERATOR clause is specified.

TRACKMOD YES or TRACKMOD NO

Specifies whether Db2 tracks modified pages in the space map pages of an implicitly created table space. The IMPTKMOD subsystem parameter specifies the default value. See [IMPTKMOD](#) in macro DSN6SYSP (Db2 Installation and Migration).

Do not specify TRACKMOD YES or TRACKMOD NO if the table space name is specified by using the IN *table-space-name* clause or if using the IN ACCELERATOR clause.

TRACKMOD YES

Changed pages are tracked in the space map pages to help improve performance of incremental image copies.

TRACKMOD NO

Changed pages are not tracked in the space map pages. Db2 uses the LRSN value in each page to determine whether a page has been changed.

PAGENUM

Identifies the type of page numbering that is used when you create a partition-by-range table space. This value is applied to an implicitly created base table space. The PAGESET_PAGENUM subsystem parameter specifies the default PAGENUM value. See [PAGE SET PAGE NUMBERING field \(PAGESET_PAGENUM subsystem parameter\)](#) (Db2 Installation and Migration).

RELATIVE

Indicates that internal page numbering is kept as a 4-byte value without a partition number. The page number is a relative page from the start of the partition, and the partition number is kept only in the header page.

ABSOLUTE

Indicates that internal page numbering is kept as a 4-byte value that includes a partition number and page number. Distinguishing which bits represent the partition and which represent the page number requires a shift value. The shift value is LOG base 2 (DSSIZE/(page size)).

Notes for CREATE TABLE

Owner privileges

The owner of the table has all table privileges (see [“GRANT statement \(table or view privileges\)”](#) on page 1988) with the ability to grant these privileges to others. For more information about ownership of the object, see [“Authorization, privileges, permissions, masks, and object ownership”](#) on page 90.

Table design

Designing tables is part of the process of database design. For more information, see [Db2 database design \(Introduction to Db2 for z/OS\)](#).

If the IN DATABASE clause is specified without a table space name

If you specify IN DATABASE (either explicitly or by default), but do not specify a table space, a table space is implicitly created in the specified database. The name of the table space is derived from the table name. The qualifier of the table space is the same as the qualifier of the table. The owner of the table space is SYSIBM.

For more information, see [Implicitly defined table spaces \(Db2 Administration Guide\)](#).

If the IN clause is not specified

If you do not specify the IN clause, the Db2 implicitly creates a table space as described previously, but the Db2 also chooses a database. Db2 creates a name in the form of DSNnnnnn, where nnnnn is between 00001 and the maximum value of the sequence SYSIBM.DSNSEQ_IMPLICITDB, which has a default of 10000, inclusive. The owner of the database is SYSIBM.

- If DSNnnnnn already exists and is an implicitly created database, the Db2 subsystem creates the table in that database.
- If DSNnnnnn does not exist, the Db2 subsystem creates a database with the name DSNnnnnn.

If DSNnnnnn cannot be created because of a deadlock, timeout, or resource unavailable condition, the Db2 subsystem increments nnnnn by one and tries the resultant database name. If the Db2 subsystem reaches the maximum value of the sequence SYSIBM.DSNSEQ_IMPLICITDB, and the corresponding database name is not available, the Db2 subsystem sets nnnnn to 00001 and tries the resultant database name. If the Db2 subsystem attempts to create the table a number of times that is equal to the maximum value of the sequence SYSIBM.DSNSEQ_IMPLICITDB without success, an error occurs.

System objects for implicitly created table spaces

If a table space is implicitly created, all of the following required system objects are also implicitly created:

- The enforcing primary key index
- The enforcing unique key index
- Any necessary LOB table spaces, auxiliary table spaces, and auxiliary indexes
- The ROWID index (if the ROWID column is defined as GENERATED BY DEFAULT)

When Db2 implicitly creates a base table space for a table with LOB columns that can have inline LOBs, Db2 creates the base table space in reordered row format, regardless of the value of the RRF subsystem parameter.

The attributes of an implicitly created table space can be changed by using the [“ALTER TABLESPACE statement”](#) on page 1321 statement.

Creating a table in a segmented (non-UTS) table space (deprecated)

A table cannot be created in a segmented table space if any of the following conditions are true:

- [FL 504](#) The effective application compatibility of the CREATE TABLE statement is V12R1M504 or higher.
- The available space in the data set is less than the segment size specified for the table space, and
- The data set cannot be extended.

Deprecated function: [FL 504](#) Non-UTS table spaces for base tables are deprecated. CREATE TABLESPACE statements that run at application compatibility level V12R1M504 or higher always create a partition-by-growth or partition-by-range table space, and CREATE TABLE statements that specify a non-UTS table space (including existing multi-table segmented table spaces) return an error. However, you can use a lower application compatibility level to create table spaces of the deprecated types if needed, such as for recovery situations. For instructions, see [Creating non-UTS table spaces \(deprecated\)](#) (Db2 Administration Guide).

Creating a table with graphic and mixed data columns

You cannot create an ASCII or EBCDIC table with a GRAPHIC, VARGRAPHIC, or DBCLOB column or a CHAR, VARCHAR, or CLOB column defined as FOR MIXED DATA when the setting for installation option MIXED DATA is NO, unless the table is EBCDIC, and the columns are Unicode.

Creating a table with distinct type columns based on LOB, ROWID, and DECFLOAT columns

Because a distinct type is subject to the same restrictions as its source type, all the syntactic rules that apply to LOB columns (CLOB, DBCLOB, and BLOB), ROWID columns, and DECFLOAT columns apply to distinct type columns that are based on LOBs, row IDs, and DECFLOATs. For example, a table cannot have both an explicitly defined ROWID column and a column with a distinct type that is based on a row ID.

Tables with inline LOB columns

If the page size is exceeded for a table in a universal table space, Db2 recalculates the record size using 0 as the inline length for LOB columns that do not specify the INLINE LENGTH clause. A record size of 0 is used in the recalculation even if the LOB_INLINE_LENGTH subsystem parameter value is greater than 0. After the recalculation, if the page size is still exceeded, the CREATE TABLE statement returns an error.

You cannot create a table with an inline LOB column in a table space that has basic row format.

Creating a table with LOB columns

A table with a LOB column (CLOB, DBCLOB, or BLOB) must also have a ROWID column, one or more auxiliary tables, and indexes on the auxiliary tables. In many situations, Db2 can implicitly create the required objects for you. For more information, see [“ROWID columns for tables with LOB columns”](#) on page 1703 and [“Auxiliary tables and indexes for LOB columns”](#) on page 1704.

ROWID columns for tables with LOB columns

When you create the table without explicitly defining a ROWID column, Db2 implicitly generates a ROWID column for you. This column is called an *implicitly hidden ROWID column*. The implicitly hidden ROWID column has the following attributes:

- Db2 creates the column with a name of DB2_GENERATED_ROWID_FOR_LOBS nn .
Db2 appends nn only if the column name already exists in the table, replacing nn with 00 and incrementing by 1 until the name is unique within the row.
- Defines the column as GENERATED ALWAYS.
- Appends the implicitly hidden ROWID column to the end of the row after all the other explicitly defined columns.

For example, assume that Db2 generated an implicitly hidden ROWID column named DB2_GENERATED_ROWID_FOR_LOBS for table MYTABLE. The result table for a SELECT * statement for table MYTABLE would not contain that ROWID column. However, the result table for SELECT COL1, DB2_GENERATED_ROWID_FOR_LOBS would include the implicitly hidden ROWID column.

If the MIXED DATA subsystem parameter is set to YES, and a lowercase or mixed case hexadecimal constant is specified as the default value for a LOB column, the CREATE TABLE statement returns an error.

Auxiliary tables and indexes for LOB columns

The definition of a table that contains a LOB column is marked incomplete until an auxiliary table is created in a LOB table space for each LOB column in the base table and an index is created on each auxiliary table. The auxiliary table stores the actual values of a LOB column. For each LOB column in a partitioned table space, one auxiliary table and related index must be defined for each partition of the base table space.

Db2 sometimes implicitly creates the LOB table space, auxiliary table, and index on the auxiliary table for each LOB column in a table or partition. For more information, see [LOB table space implicit creation \(Db2 Administration Guide\)](#).

If Db2 does not implicitly create the LOB table spaces, auxiliary tables, and indexes on the auxiliary tables, you must create these objects by issuing CREATE TABLESPACE, CREATE AUXILIARY TABLE, and CREATE INDEX statements. For more information, see [Creating LOB table spaces, auxiliary tables, and auxiliary indexes explicitly \(Db2 Administration Guide\)](#).

Creating a table with an XML column

If the table has XML columns, the underlying XML table space is implicitly created with the same PAGENUM attribute as the base table space. The DSSIZE is inherited from the base table space for a base table in the partition-by-growth (PBG) table space.

The following table shows the DSSIZE for an implicitly created XML table space for a base table in a partition-by-range (PBR) or range-partitioned (non-UTS) table space. For partition-by-range (PBR) table spaces with relative page numbering, Db2 also rounds the DSSIZE up to the nearest power of two before using the following table.

<i>Table 207. Default DSSIZE for XML table spaces, given the base table space DSSIZE and buffer-pool page size</i>				
Base table space DSSIZE	4KB base page size	8KB base page size	16KB base page size	32KB base page size
1–4 GB	4G B	4 GB	4 GB	4 GB
5–8 GB	32 GB	16 GB	16 GB	16 GB
9–16 GB	64 GB	32 GB	16 GB	16 GB
17–32 GB	64 GB	64 GB	32 GB	16 GB
33–64 GB	64 GB	64 GB	64 GB	32 GB
65–128 GB	256 GB	256 GB	128 GB	64 GB
129–256 GB	256 GB	256 GB	256 GB	128 GB
257–512 GB	512 GB	512 GB	512 GB	256 GB
513-1024 GB	1024 GB	1024 GB	1024 GB	512 GB

For more information, see [XML table space implicit creation \(Db2 Administration Guide\)](#).

Naming convention for implicitly created XML objects

Implicitly created XML table spaces names will be Xyyyynnnn, where yyy is derived from the first three bytes of the base table name (if the name is shorter than 3, yyy is padded with X). nnnn is a numeric string that will start at 0000 and be incremented by 1 until a unique number is found.

Implicitly created XML table names will be Xyyyyyyyyyyyyyyyyynnn, where yyyyyyyyyyyyyyyyyy is the first 18 UTF-8 bytes of the base table name or of the entire name if it is less than 18. nnn will only be appended if the name already exists in the table. If the name already exists, nnn will be replaced with 000 and will be incremented by 1 until the name is unique.

Implicitly created document ID index names will be I_DOCIDyyyyyyyyyyyyyyyyyyyynnn, where yyyyyyyyyyyyyyyyyyy is the first 18 UTF-8 bytes of the base table name or the entire name if it is less than 18. nnn will only be appended if the index already exists in the table. If the index already exists, nnn will be replaced with 000 and will be incremented by 1 until the name is unique.

Implicitly created node ID index names will be I_NODEIDyyyyyyyyyyyyyyyyyyyynnn, where yyyyyyyyyyyyyyyyyyy is the first 18 UTF-8 bytes of the XML table name or the entire name if it is less than 18. nnn will only be appended if the index already exists in the table. If the index already exists, nnn will be replaced with 000 and will be incremented by 1 until the name is unique.

Creating a table with an identity column

When a table has an identity column, Db2 can automatically generate sequential numeric values for the column as rows are inserted into the table. Thus, identity columns are ideal for primary keys. Identity columns and ROWID columns are similar in that both types of columns contain values that Db2 generates. ROWID columns are used in large object (LOB) table spaces and can be useful in direct-row access. ROWID columns contain values of the ROWID data type, which returns a 40-byte VARCHAR value that is not regularly ascending or descending. ROWID data values are therefore not well suited to many application uses, such as generating employee numbers or product numbers. For data that is not LOB data and that does not require direct-row access, identity columns are usually a better approach, because identity columns contain existing numeric data types and can be used in a wide variety of uses for which ROWID values would not be suitable.

When a table is recovered to a point-in-time, it is possible that a large gap in the generated values for the identity column might result. For example, assume a table has an identity column that has an incremental value of 1 and that the last generated value at time T1 was 100 and Db2 subsequently generates values up to 1000. Now, assume that the table space is recovered back to time T1. The generated value of the identity column for the next row that is inserted after the recovery completes will be 1001, leaving a gap in the range 100–1001 in the values of the identity column.

If you want to ensure that an identity column has unique values, create a unique index on the column.

Creating a table with a LONG VARCHAR or LONG VARGRAPHIC column

Although the syntax LONG VARCHAR and LONG VARGRAPHIC is allowed for compatibility with previous releases of Db2, its use is not encouraged. VARCHAR(*integer*) and VARGRAPHIC(*integer*) is the recommended syntax, because after the CREATE TABLE statement is processed, Db2 considers a LONG VARCHAR column to be VARCHAR and a LONG VARGRAPHIC column to be VARGRAPHIC.

When a column is defined using the LONG VARCHAR or LONG VARGRAPHIC syntax, Db2 determines the length attribute of the column. You can use the following information, which is provided for existing applications that require the use of the LONG VARCHAR or LONGVARGRAPHIC syntax, to calculate the byte count and the character count of the column.

To calculate the byte count, use this formula:

$$2*(INTEGER((INTEGER((m-i-k)/j))/2))$$

Where:

m

Is the maximum row size (8 less than the maximum record size)

i

Is the sum of the byte counts of all columns in the table that are not LONG VARCHAR or LONG VARGRAPHIC

j

is the number of LONG VARCHAR and LONG VARGRAPHIC columns in the table

k

k is the number of LONG VARCHAR and LONG VARGRAPHIC columns that allow nulls

To find the character count:

1. Find the byte count.
2. Subtract 2.

3. If the data type is LONG VARCHAR, divide the result by 2. If the result is not an integer, drop the fractional part.

Defining a system-period temporal table

A system-period temporal table definition includes the following:

- A system period named SYSTEM_TIME which is defined using a row-begin column and a row-end column.
- A transaction-start-ID column.
- A system-period data versioning definition which includes the name of the associated history table, which is specified in a subsequent ALTER TABLE statement.

To ensure that the history table cannot be implicitly dropped when a system-period temporal table is dropped, use the WITH RESTRICT ON DROP clause in the definition of the history table.

Defining an application-period temporal table

An application-period temporal table definition includes an application period named BUSINESS_TIME. The application period is defined using a begin timestamp column and an end timestamp column.

Data change operations on an application-period temporal table might result in an automatic insert of one or two additional rows when a row is updated or deleted. When an update or delete of a row in an application-period temporal table is specified for a portion of the period that is represented by that row, the row is updated or deleted and one or two rows are automatically inserted to represent the portion of the row that is not changed. New values are generated for each generated column in an application-period temporal table for each row that is automatically inserted as a result of an update or delete operation on the table. If a generated column is defined as part of a unique or primary key, parent key in a referential constraint, or unique index, it is possible that an automatic insert will violate a constraint or index, in which case an error is returned.

Bitemporal tables

A table that is defined for system-period data versioning and contains a BUSINESS_TIME period is referred to as a bitemporal table.

Considerations for transaction-start-ID columns

A transaction-start-ID column contains a null value if the column allows null values. A row-begin column which is unique from other row-begin column values that are generated for other transactions exists with the transaction-start-ID column. Given that the column might contain null values, consider using one of the following methods when retrieving a value from the column:

```
COALESCE ( transaction_start_id_col, row_begin_col)
CASE WHEN transaction_start_id_col IS NOT NULL
      THEN transaction_start_id_col
      ELSE row_begin_col
END
```

Implicitly created indexes

When the PRIMARY KEY or UNIQUE clause is used in the CREATE TABLE statement and the CREATE TABLE statement is processed by the schema processor or the table space that contains the table is implicitly created, Db2 implicitly creates the unique indexes used to enforce the uniqueness of the primary or unique keys.

When a ROWID column is defined as GENERATED BY DEFAULT in the CREATE TABLE statement, and the CREATE TABLE statement is processed by SET CURRENT RULES = 'STD' or the table space that contains the table is implicitly created, Db2 implicitly creates the unique indexes used to enforce the uniqueness of the ROWID column.

The privilege set must include the USE privilege of the buffer pool.

Each index is created as if the following CREATE INDEX statement were issued:

```
CREATE UNIQUE INDEX xxx ON table-name (column1,...)
```

Where:

- *xxx* is the name of the index that Db2 generates.
- *table-name* is the name of the table specified in the CREATE TABLE statement.
- (*column1,...*) is the list of column names that were specified in the UNIQUE or PRIMARY KEY clause of the CREATE TABLE statement, or the column is a ROWID column that is defined as GENERATED BY DEFAULT.

For more information about the schema processor, see [Creating a schema by using the schema processor \(Db2 Administration Guide\)](#).

In addition, if a table space that contains the table is implicitly created, Db2 will check the DEFINE DATA SET subsystem parameter to determine whether to define the underlying data set for the index space of the implicitly created index on the base table.

If DEFINE DATA SET is NO, the index is created as if the following CREATE INDEX statement is issued:

```
CREATE UNIQUE INDEX xxx ON table-name (column1,...) DEFINE NO
```

Maximum record size

The maximum record size of a table depends on the page size of the table space and whether the EDITPROC clause is specified, as shown in [Table 208 on page 1707](#).

The initial page size of the table space is the size of its buffer, which is determined by the BUFFERPOOL clause that was explicitly or implicitly specified when the table space was created. When the record size reaches 90 percent of the maximum record size for the page size of the table space, the next largest page size is automatically used.

Table 208. Maximum record size, in bytes

	Page Size = 4KB	Page Size = 8KB	Page Size = 16KB	Page Size = 32KB
Table without EDITPROC=YES	4056	8138	16330	32714
Table with EDITPROC=YES	4046	8128	16320	32704

The maximum record size corresponds to the maximum length of a VARCHAR column if that column is the only column in the table.

If the table space that contains the table is implicitly created, the proper buffer pool size is chosen according to the actual record size. If the record size reaches 90% of the maximum record size for the page size of the table space, the next largest page size will be used. [Table 209 on page 1707](#) shows 90% of the maximum record size:

Table 209. 90% of Maximum record size, in bytes

	Page Size = 4KB	Page Size = 8KB	Page Size = 16KB	Page Size = 32KB
Table without EDITPROC=YES	3650	7324	14697	29443
Table with EDITPROC=YES	3641	7315	14688	29434

A row in a table with PAGENUM RELATIVE or in a table space with PAGENUM RELATIVE must have a minimum data size of 3 bytes. Rows with data that compresses to less than 3 bytes, will not be compressed when stored in the table.

Byte counts

The sum of the byte counts of the columns must not exceed the maximum row size of the table. The maximum row size is eight less than the maximum record size.

For columns that do not allow null values, Table 210 on page 1708 gives the byte counts of columns by data type. For columns that allow null values, the byte count is one more than shown in the table.

Table 210. Byte counts of columns by data type

Data Type	Byte Count
INTEGER	4
SMALLINT	2
BIGINT	8
FLOAT(<i>n</i>)	If <i>n</i> is in the range 1–21, the byte count is 4. If <i>n</i> is in the range 22–53, the byte count is 8.
DECIMAL	INTEGER($(p/2)+1$), where <i>p</i> is the precision
DECFLOAT(16)	9
DECFLOAT(34)	17
CHAR(<i>n</i>)	<i>n</i>
VARCHAR(<i>n</i>)	<i>n</i> +2
CLOB	6
Inline CLOB	6 + inline byte count
GRAPHIC(<i>n</i>)	2 <i>n</i>
VARGRAPHIC(<i>n</i>)	2 <i>n</i> +2
DBCLOB	6
Inline DBCLOB	6 + (inline char count * 2)
BINARY(<i>n</i>)	<i>n</i>
VARBINARY(<i>n</i>)	<i>n</i> +2
BLOB	6
Inline BLOB	6 + inline byte count
DATE	4
TIME	3
TIMESTAMP(<i>p</i>) WITHOUT TIME ZONE	INTEGER($(p+1)/2$) + 7 where <i>p</i> is the precision
TIMESTAMP(<i>p</i>) WITH TIME ZONE	INTEGER($(p+1)/2$) + 9 where <i>p</i> is the precision
ROWID	19
distinct type	The length of the source data type upon which the distinct type was based
XML	6 - If column cannot contain multiple versions of an XML document. 14 - If column can contain multiple versions of an XML document.

For more information, see [How Db2 uses XML versions \(Db2 Programming for XML\)](#).

Creating a materialized query table

If the fullselect in the CREATE TABLE statement contains a SELECT *, the select list of the subselect is determined at the time the materialized query table is created. In addition, any references to user-defined functions are resolved at the same time. The isolation level at the time when the CREATE TABLE statement is executed is the isolation level for the materialized query table. After a materialized query table is created, the REFRESH_TIME column of the row for the table in the SYSIBM.SYSVIEWS catalog table contains the default timestamp.

The owner of a materialized query table has all the table privileges with the grant option on the table irrespective of whether the owner has the necessary privileges on the base tables, views, functions, and sequences.

No unique constraints or unique indexes can be created for materialized query tables. Thus, a materialized query table cannot be a parent table in a referential constraint.

When you are creating user-maintained materialized query tables, you should create the materialized query table with query optimization disabled and then enable the table for query optimization after it is populated. Otherwise, Db2 might rewrite queries to use the empty materialized query table, and you will not get accurate results.

Considerations for implicitly hidden columns

A column that is defined as implicitly hidden is not part of the result table of a query that specifies * in a SELECT list. However, an implicitly hidden column can be explicitly referenced in a query. For example, an implicitly hidden column can be referenced in the SELECT list or in a predicate in a query. Additionally, an implicitly hidden column can be explicitly referenced in a COMMENT, CREATE INDEX statement, ALTER TABLE statement, INSERT statement, MERGE statement, UPDATE statement, or RENAME statement. An implicitly hidden column can be referenced in a referential constraint. A REFERENCES clause that does not contain a column list refers implicitly to the primary key of the parent table. It is possible that the primary key of the parent table includes a column defined as implicitly hidden. Such a referential constraint is allowed.

If the SELECT list of the fullselect of a materialized query definition explicitly refers to an implicitly hidden column, that column will be part of the materialized query table.

If the SELECT list of the fullselect of a view definition (CREATE VIEW statement) explicitly refers to an implicitly hidden column, that column will be part of the view, however the view column is not considered 'hidden'.

Restrictions on field procedures, edit procedures, and validation exit procedures

Field procedures, edit procedures, and validation exit procedures cannot be used on tables that have column names that are larger than 18 EBCDIC bytes. If you have tables that have field procedures or validation exit procedures and you add a column where the column name is larger than 18 bytes, the field procedures and validation exit procedures for the table will be invalidated.

Consider using triggers to replace the functionality on field procedures, edit procedures, and validation exit procedures on tables where the column names are larger than 18 EBCDIC bytes.

Restrictions on certain SQL statements in the same unit of work as CREATE TABLE

- A CREATE TABLE statement that contains a PARTITION BY clause should not be followed in the same unit of work by SQL statements that change data.
- A CREATE TABLE statement that contains an IN ACCELERATOR clause should be issued in a separate unit of work from other SQL statements.

Creating a table while a utility runs

You cannot use CREATE TABLE while a Db2 utility has control of the table space implicitly or explicitly specified by the IN clause.

Restrictions involving pending definition changes

A CREATE TABLE statement is not allowed if there are pending changes to the definition of the table space, if the CREATE TABLE statement specifies a FOREIGN KEY clause that reference a column for which there are pending definition changes, or if the CREATE TABLE statement specifies

a materialized query table definition that references a table for which there are pending definition changes.

Key label requirement

To use a key label for encryption, the VSAM data sets for the page sets need to be associated with an SMS Data Class that has extended format capability (EF enabled).

Determining a key label for base table space and associated objects

When a key label is specified at the table level, Db2 provides the key label to DFSMS to encrypt all the table spaces and index spaces associated with the table. This includes base table space, auxiliary table spaces, XML table spaces, index spaces, and clone table space, regardless of whether the base table space or associated objects are explicitly or implicitly created. Db2 does not enforce any key label relationship between the base table and an associated history or archive table. The key label for the archive and the history tables has to be set independent of the base table. If there is no key label specified at the table level, Db2 will provide the key label to DFSMS specified for the storage group.

When Db2 calls DFSMS to allocate the dataset for table space or index space, DFSMS uses its order of precedence to determine the key label and can override the key label specified by Db2.

DFSMS order of precedence:

- RACF data set profile
- JCL, dynamic allocation, TSO ALLOCATE
- SMS data class construct

If the security administrator has specified a key label for the RACF data set profile, that key label takes precedence over the Db2 provided key label. The REPORT utility can be run to determine the key label used for encryption.

Description of key label in effect in DB2

Table 211. Example scenarios for a partition-by-growth table space, that describe the key label in effect in DB2. This is the key label provided to DFSMS during allocation of data set for table spaces and index spaces.

Scenarios	Catalog key label value	Key label provided to DFSMS during data set allocation
Create storage group, SG01 with key label, SGKL01.	SYSSTOGROUP record - KEY LABEL: SGKL01	
Create table space, TBSP01 using storage group, SG01 – Creates Partition 1		SGKL01
Create table, TB01 in table space, TBSP01 with key label, TBKL01	SYSTABLESPACE record for TBSP01 / SYSTABLES record for TBKL01 – KEY LABEL: TBKL01	
REORG TABLESPACE TBSP01 – Reorgs Partition 1		TBKL01
Create index, IX01 on table, TB01 creates index space	SYSINDEXES record for IX01 – KEY LABEL: TBKL01	TBKL01
Insert data into TB01 – Creates Partition 2		TBKL01
Alter table, TB01 to specify NO KEY LABEL	SYSTABLESPACE record for TBSP01 / SYSTABLES record for TBKL01 / SYSINDEXES record for IX01 – KEY LABEL: Empty string	
Insert data into TB01 – Creates partition 3		SGKL01

Table 211. Example scenarios for a partition-by-growth table space, that describe the key label in effect in DB2. This is the key label provided to DFSMS during allocation of data set for table spaces and index spaces. (continued)

Scenarios	Catalog key label value	Key label provided to DFSMS during data set allocation
REORG TABLESPACE TBSP01 with REUSE option – Resets and reuses DB2-managed data sets. No change to key label		

Key label considerations

If the last table is dropped from a segmented table space, the table space and its underlying data set will remain. If key label is in effect, the KEYLABEL column for the table space's SYSTABLESPACE record will be cleared. If a new table is created in this table space, it will be encrypted with the previous key label. If the table has to be created as unencrypted, execute the REORG TABLESPACE utility for the table space.

If a table space is explicitly created with the DEFINE YES option and a table with a key label is defined in that table space, then the data sets associated with the table space will not be encrypted. A subsequent REORG is necessary to encrypt the data sets. Users that want immediate encryption of the data sets associated with the table space must to define table spaces with the DEFINE NO option.

Syntax and descriptions for hash organization (deprecated)

Deprecated function: FL 504 Hash-organized tables are deprecated. Beginning in Db2 12, packages bound with APPLCOMPAT(V12R1M504) or higher cannot create hash-organized tables or alter existing tables to use hash-organization. Existing hash organized tables remain supported, but they are likely to be unsupported in the future.

organization-clause

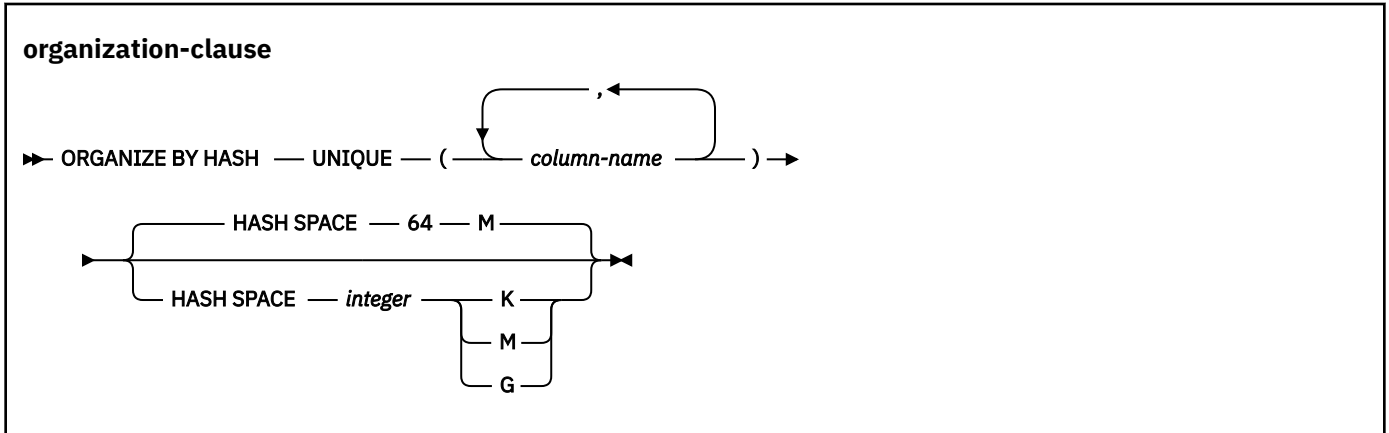

ORGANIZE BY HASH

Specifies that a hash is to be used for the data organization of the table.

If `PARTITION BY RANGE` is specified, and the `IN` clause specifies a table space, the table space must be a partition by range universal table space, and cannot be a table space with `PAGENUM RELATIVE`.

If `PARTITION BY RANGE` is not specified, and an `IN` clause is specified, the `IN` clause must identify a partition-by-growth table space.

`ORGANIZE BY HASH` must not be specified if the table is defined with `APPEND YES`.

`ORGANIZE BY HASH` must not be specified if the table is using basic row format.

If `IN ACCELERATOR` is specified, `ORGANIZE BY HASH` must not be specified.

UNIQUE

Specifies that Db2 enforces uniqueness of the hash key columns, preventing the table from containing two or more rows with the same value of the hash key.

(*column-name*, ...)

The list of column names defines the hash key that is used to determine where a row will be placed. Each *column-name* must be an unqualified name that identifies a column of the table. The same column must not be specified more than once and the specified columns must be defined as NOT NULL. The number of specified columns must not exceed 64, and the sum of their length attributes must not exceed 255. A specified column cannot be any of the following types:

- a LOB column
- a DECFLOAT column
- a XML column
- a distinct type column that is based on one of the preceding data types

All character and graphic string columns in the key must use the same encoding scheme.

If PARTITION BY RANGE is also specified, the list of column names must specify all of the column names that are specified in *partition-expression* for the table, and must specify the column names in the same order as *partition-expression*. If the ORGANIZE BY clause contains more columns than *partition-expression*, *partition-expression* determines the partition number.

HASH SPACE *integer*K|M|G

Specifies the amount of fixed hash space to preallocate for the table. If the table is partitioned by range, this is the space for each partition.

The default is 64M for a table in a partition-by-growth table space or 64M for each partition of a partition-by-range table space.

K

Indicates that the *integer* value is multiplied by 1024 to specify the hash space size in bytes. The *integer* value must be in the range 256–268,435,456.

M

Indicates that the *integer* value is multiplied by 1,048,576 to specify the hash space size in bytes. The *integer* value must be in the range 1–262,144.

G

Indicates that the *integer* value is to be multiplied by 1,073,741,824 to specify the hash space size in bytes. The *integer* value must be in the range 1–256 for a partition by range table and must be in the range 1–131,072 for a non-partitioned table.

If a value greater than 4G is specified, the data sets for the table space are associated with a DFSMS data class that has been specified with extended format and extended addressability.

partition-hash-space

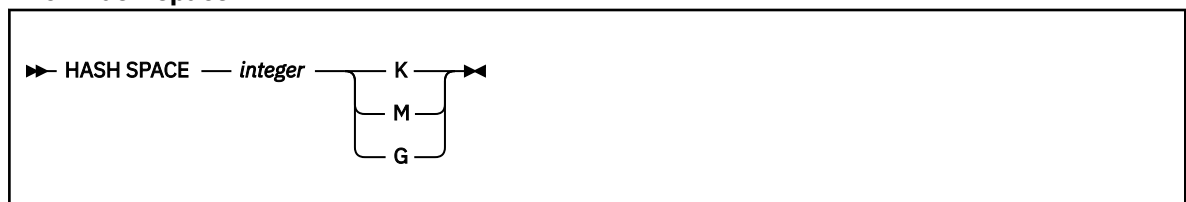

HASH SPACE *integer*K|M|G

Specifies the amount of fixed hash space to preallocate for the partition that is associated with the *partition-element*. If HASH SPACE is omitted from the partition element, the HASH SPACE value from the ORGANIZE BY clause is used. If IN ACCELERATOR is specified, HASH SPACE must not be specified.

If HASH SPACE is not specified, each partition will use the HASH SPACE value specified in *organization-clause*.

The HASH SPACE keyword in *partition-element* must only be specified if *organization-clause* is also specified.

K

Indicates that the *integer* value is multiplied by 1024 to specify the hash space size in bytes. The *integer* value must be in the range 256–268,435,456.

M

Indicates that the *integer* value is multiplied by 1,048,576 to specify the hash space size in bytes. The *integer* value must be in the range 1–262,144.

G

Indicates that the *integer* value is to be multiplied by 1,073,741,824 to specify the hash space size in bytes. The *integer* value must be in the range 1–256 for a partition by range table and must be in the range 1–131,072 for a non-partitioned table.

If a value greater than 4G is specified, the data sets for the table space are associated with a DFSMS data class that has been specified with extended format and extended addressability.

Notes for hash organization (deprecated)

Deprecated function: FL 504 Hash-organized tables are deprecated. Beginning in Db2 12, packages bound with APPLCOMPAT (V12R1M504) or higher cannot create hash-organized tables or alter existing tables to use hash-organization. Existing hash organized tables remain supported, but they are likely to be unsupported in the future.

If the IN clause is not specified with ORGANIZE BY HASH

If you do not specify IN DATABASE (either explicitly or by default), Db2 will use the default DSSIZE of 4G for each partition for a partition-by-range table space or use the value that is specified in the partitioning clause. The hash space value that is specified on CREATE TABLE will be validated, per part, to ensure that the specified DSSIZE is adequate. If the DSSIZE is not adequate, an error will be returned.

If the maximum number of partitions needed for the specified hash space is more than the maximum number of partitions allowed, Db2 will return an error.

If the selected buffer pool is not available, an error will be returned.

Creating a table with hash organization and LOB columns

If the table space is a partition-by-growth table space, Db2 will preallocate as many partitions as needed depending on the value specified for HASH SPACE. If Db2 needs to implicitly create the LOB object in a new partition, the privilege set for the implicitly created LOB objects must include the USE privilege on the buffer pool for the LOB table space.

Hash space and Db2 page size

If the specified hash space is less than or equal to 64 MB (the Db2 default), Db2 will add extra space for Db2 system pages. If the specified hash space is greater than 64 MB, Db2 will use part of the hash space for Db2 system pages. The amount of space needed for Db2 system pages depends on SEGSIZE and PAGESIZE. The larger the SEGSIZE and/or PAGESIZE becomes, the larger the requirement for Db2 system pages. Db2 can reserve up to 5 MB for system pages for the highest SEGSIZE value (64) and PAGESIZE value (32K).

Hash space and DSSIZE

Depending on certain table space characteristics, Db2 needs to reserve space for the hash overflow area. Therefore, the amount of hash space cannot be equal to the DSSIZE value. The maximum amount of hash space that can be specified is approximately 20% less than the DSSIZE value. Db2 returns an error if the amount of hash space is too large. If the amount of hash space is too large, specify a larger value of DSSIZE, or decrease the amount of hash space.

Specifying APPEND for hash-organized tables

Append processing is not applicable to tables with hash organization since there is no key clustering in hash organization. For insert operations into tables with hash organization, Db2 will use the internal hash algorithm to determine the location of the row.

Maximum record size for hash-organized tables

For hash-organized tables, the maximum record size on whether the EDITPROC clause is specified, as shown in [Table 212 on page 1714](#).

The initial page size of the table space is the size of its buffer, which is determined by the BUFFERPOOL clause that was explicitly or implicitly specified when the table space was created. When the record size reaches 90 percent of the maximum record size for the page size of the table space, the next largest page size is automatically used.

Table 212. Maximum record size, in bytes for hash organized tables

	Page Size = 4KB	Page Size = 8KB	Page Size = 16KB	Page Size = 32KB
Hash table (hash home page)	3817	7899	16091	32475
Hash table with EDITPROC=YES (hash home page)	3807	7889	16081	32465

The maximum record size corresponds to the maximum length of a VARCHAR column if that column is the only column in the table.

If the table space that contains the table is implicitly created, the proper buffer pool size is chosen according to the actual record size.

A row in a table with PAGENUM RELATIVE or in a table space with PAGENUM RELATIVE must have a minimum data size of 3 bytes. Rows with data that compresses to less than 3 bytes, will not be compressed when stored in the table.

Restrictions for tables with hash organization

Tables that use hash organization are subject to the following restrictions:

- A table that is defined to use hash organization cannot be created in a LOB table space or XML table space.
- ORGANIZE BY HASH must not be specified if the table space is defined with the MEMBER CLUSTER clause.
- The MAXROWS clause is applicable only to the hash overflow area of the table space for tables with hash organization. The fixed hash area of each page will contain as many rows as it can hold, up to a maximum of 255.
- The ORGANIZE BY HASH UNIQUE (*column-list*) clause is required when specifying HASH SPACE *integer* K|M|G in the *partition-element*. The *organization-clause* applies to the entire table and the *partition-element* clause applies at the partition level.
- Db2 automatically creates a hash overflow index when a table is created with hash organization.

Alternative syntax and synonyms

To provide compatibility with previous releases of Db2 or other products in the Db2 family, Db2 supports the following clauses:

- NOCACHE (single clause) as a synonym for NO CACHE
- NOCYCLE (single clause) as a synonym for NO CYCLE
- NOMINVALUE (single clause) as a synonym for NO MINVALUE
- NOMAXVALUE (single clause) as a synonym for NO MAXVALUE
- NOORDER (single clause) as a synonym for NO ORDER
- PART *integer* VALUES can be specified as an alternative to PARTITION *integer* ENDING AT.
- VALUES as a synonym for ENDING AT
- DEFINITION ONLY as a synonym for WITH NO DATA

- SUMMARY between CREATE and TABLE
- TIMEZONE can be specified as an alternative to TIME ZONE.

Examples for CREATE TABLE

Example 1

Create a table named DSN8C10.DEPT in the table space DSN8S12D of the database DSN8D12A. Name the five columns DEPTNO, DEPTNAME, MGRNO, ADMRDEPT, and LOCATION, allowing only MGRNO and LOCATION to contain nulls, and designating DEPTNO as the only column in the primary key. All five columns hold character string data. Assuming a value of NO for the field MIXED DATA on installation panel DSNTIPF, all five columns have the subtype SBCS.

```
CREATE TABLE DSN8C10.DEPT
(DEPTNO CHAR(3) NOT NULL,
DEPTNAME VARCHAR(36) NOT NULL,
MGRNO CHAR(6)
,
ADMRDEPT CHAR(3) NOT NULL,
LOCATION CHAR(16)
,
PRIMARY KEY(DEPTNO)
)
IN DSN8D12A.DSN8S12D;
```

Example 2

Create a table named DSN8C10.PROJ in an implicitly created table space of the database DSN8D12A. Assign the table a validation procedure named DSN8EAPR.

```
CREATE TABLE DSN8C10.PROJ
(PROJNO CHAR(6) NOT NULL,
PROJNAME VARCHAR(24) NOT NULL,
DEPTNO CHAR(3) NOT NULL,
RESPEMP CHAR(6) NOT NULL,
PRSTAFF DECIMAL(5,2)
,
PRSTDATE DATE
,
PRENDATE DATE
,
MAJPROJ CHAR(6) NOT NULL)
IN DATABASE DSN8D12A
VALIDPROC DSN8EAPR;
```

Example 3

Assume that table PROJECT has a non-primary unique key that consists of columns DEPTNO and RESPEMP (the department number and employee responsible for a project). Create a project activity table named ACTIVITY with a foreign key on that unique key.

```
CREATE TABLE ACTIVITY
(PROJNO CHAR(6) NOT NULL,
ACTNO SMALLINT NOT NULL,
ACTDEPT CHAR(3) NOT NULL,
ACTOWNER CHAR(6) NOT NULL,
ACSTAFF DECIMAL(5,2)
,
ACSTDATE DATE NOT NULL,
ACENDATE DATE
,
FOREIGN KEY (ACTDEPT,ACTOWNER)
REFERENCES PROJECT (DEPTNO,RESPEMP) ON DELETE RESTRICT)
IN DSN8D12A.DSN8S12D;
```

Example 4

Create an employee photo and resume table EMP_PHOTO_RESUME that complements the sample employee table. The table contains a photo and resume for each employee. Put the table in table space DSN8D12A.DSN8S12E. Let Db2 always generate the values for the ROWID column.

```
CREATE TABLE DSN8C10.EMP_PHOTO_RESUME
(EMPNO CHAR(6) NOT NULL,
EMP_ROWID ROWID NOT NULL GENERATED ALWAYS,
EMP_PHOTO BLOB(110K),
RESUME CLOB(5K),
PRIMARY KEY (EMPNO))
```

```
IN DSN8D12A.DSN8S12E
CCSID EBCDIC;
```

Example 5

Create an EMPLOYEE table with an identity column named EMPNO. Define the identity column so that Db2 will always generate the values for the column. Use the default value, which is 1, for the first value that should be assigned and for the incremental difference between the subsequently generated consecutive numbers.

```
CREATE TABLE EMPLOYEE
(EMPNO      INTEGER GENERATED ALWAYS AS IDENTITY,
 ID         SMALLINT,
 NAME      CHAR(30),
 SALARY    DECIMAL(5,2),
 DEPTNO    SMALLINT)
IN DSN8D12A.DSN8S12D;
```

Example 6

Assume a very large transaction table named TRANS contains one row for each transaction processed by a company. The table is defined with many columns. Create a materialized query table for the TRANS table that contain daily summary data for the date and amount of a transaction.

```
CREATE TABLE STRANS AS
(SELECT YEAR AS SYEAR, MONTH AS SMONTH, DAY AS SDAY, SUM(AMOUNT) AS SSUM
FROM TRANS
GROUP BY YEAR, MONTH, DAY)
DATA INITIALLY DEFERRED REFRESH DEFERRED;
```

Example 7

The following example creates a table in a partition-by-growth table space and includes the APPEND option:

```
CREATE TABLE TS01TB
(C1 SMALLINT,
 C2 DECIMAL(9,2),
 C3 CHAR(4))
APPEND YES
IN TS01DB.TS01TS;
```

Example 8

The following example creates a table in a partition-by-growth table space where the table space is implicitly created:

```
CREATE TABLE TS02TB
(C1 SMALLINT,
 C2 DECIMAL(9,2),
 C3 CHAR(4))
PARTITION BY SIZE EVERY 4G
IN DATABASE DSNDB04;
```

Example 9

Create a table, EMP_INFO, that contains a phone number and address for each employee. Include a row change timestamp column in the table to track the modification of employee information:

```
CREATE TABLE EMP_INFO
(EMPNO CHAR(6) NOT NULL,
 EMP_INFOCHANGE NOT NULL
GENERATED ALWAYS FOR EACH ROW ON UPDATE
AS ROW CHANGE TIMESTAMP,
EMP_ADDRESS VARCHAR(300),
EMP_PHONENO CHAR(4),
PRIMARY KEY (EMPNO));
```

Example 10

Create a table, TB01, that uses a range partitioning scheme with a segment size of 4 and 4 partitions.

```
CREATE TABLE TB01 (
ACCT_NUM      INTEGER,
CUST_LAST_NM  CHAR(15),
```



```

LAST_ACTIVITY_DT VARCHAR(25),
COL2             CHAR(10),
COL3             CHAR(25),
COL4             CHAR(25),
COL5             CHAR(25),
COL6             CHAR(55),
STATE           CHAR(55)
IN DBB.TS01

PARTITION BY (ACCT_NUM)
(PARTITION 1 ENDING AT (199),
PARTITION 2 ENDING AT (299),
PARTITION 3 ENDING AT (399),
PARTITION 4 ENDING AT (MAXVALUE));

```

Example 11

Create a table, `policy_info`, that uses a `SYSTEM_TIME` period and create a history table, `hist_policy_info`. Then issue an `ALTER TABLE` statement to associate the `policy_info` table with the `hist_policy_info` table.

```

CREATE TABLE policy_info
(policy_id CHAR(10) NOT NULL,
 coverage INT NOT NULL,
 sys_start TIMESTAMP(12) NOT NULL GENERATED ALWAYS AS ROW BEGIN,
 sys_end  TIMESTAMP(12) NOT NULL GENERATED ALWAYS AS ROW END,
 create_id TIMESTAMP(12) GENERATED ALWAYS AS TRANSACTION START ID,
 PERIOD SYSTEM_TIME(sys_start, sys_end));

```

```

CREATE TABLE hist_policy_info
(policy_id CHAR(10) NOT NULL,
 coverage INT NOT NULL,
 sys_start TIMESTAMP(12) NOT NULL,
 sys_end  TIMESTAMP(12) NOT NULL,
 create_id TIMESTAMP(12));

```

```

ALTER TABLE policy_info
ADD VERSIONING USE HISTORY TABLE hist_policy_info;

```

Example 12

Create a table, `policy_info`, that uses a `BUSINESS_TIME` period.

```

CREATE TABLE policy_info
(policy_id CHAR(4) NOT NULL,
 coverage INT NOT NULL,
 bus_start DATE NOT NULL,
 bus_end  DATE NOT NULL,
 PERIOD BUSINESS_TIME(bus_start, bus_end));

```

Example 13

Create a table, `policy_info`, that uses both a `SYSTEM_TIME` period and a `BUSINESS_TIME` period to keep historical rows and track a user-specified time period. A table that specifies both a `SYSTEM_TIME` period and a `BUSINESS_TIME` period is sometimes referred to as a *bitemporal table*. To enable retention of historical rows, a history table, `hist_policy_info`, also needs to be created and associated (using the `ALTER TABLE` statement) with the `policy_info` table.

```

CREATE TABLE policy_info
(policy_id CHAR(4) NOT NULL,
 coverage INT NOT NULL,
 bus_start DATE NOT NULL,
 bus_end  DATE NOT NULL,
 sys_start TIMESTAMP(12) NOT NULL GENERATED ALWAYS AS ROW BEGIN,
 sys_end  TIMESTAMP(12) NOT NULL GENERATED ALWAYS AS ROW END,
 create_id TIMESTAMP(12) GENERATED ALWAYS AS TRANSACTION START ID,
 PERIOD BUSINESS_TIME(bus_start, bus_end),
 PERIOD SYSTEM_TIME(sys_start, sys_end));

```

```

CREATE TABLE hist_policy_info
(policy_id CHAR(4) NOT NULL,
 coverage INT NOT NULL,
 bus_start DATE NOT NULL,
 bus_end  DATE NOT NULL,

```

```
sys_start TIMESTAMP(12) NOT NULL,  
sys_end TIMESTAMP(12) NOT NULL),  
create_id TIMESTAMP(12);
```

```
ALTER TABLE policy_info  
ADD VERSIONING USE HISTORY TABLE hist_policy_info;
```

Example 14: Create table EMPLOYEE.PERSONAL with key label EMPKEYLABEL.

```
CREATE TABLE EMPLOYEE.PERSONAL  
(DEPTNO CHAR(3) NOT NULL,  
DEPTNAME VARCHAR(36) NOT NULL,  
MGRNO CHAR(6),  
ADMRDEPT CHAR(3) NOT NULL,  
LOCATION CHAR(16),  
PRIMARY KEY (DEPTNO) )  
IN DSN8D12A.DSN8S12D  
KEY LABEL EMPKEYLABEL;
```

Related concepts

[Types of accelerator tables \(Db2 Performance\)](#)

[Unicode columns in EBCDIC tables](#)

A single encoding scheme is used for all character and character string data in a table. An exception is that an EBCDIC table can contain one or more Unicode columns in addition to EBCDIC string columns.

[Unicode support in Db2 \(Db2 Installation and Migration\)](#)

[Naming conventions](#)

The rules for forming a name depend on the type of the object designated by the name.

Related tasks

[Creating tables from application programs \(Db2 Application programming and SQL\)](#)

Related reference

[EBCDIC and ASCII support \(Db2 Installation and Migration\)](#)

Related information

[Implementing Db2 tables \(Db2 Administration Guide\)](#)

[Conditions that prevent query routing to an accelerator](#)

CREATE TABLESPACE statement

The CREATE TABLESPACE statement defines a table space at the current server. The type of table space depends on the keywords specified.

FL 504 Depending on the keywords specified, the result is a partition-by-range or partition-by-growth table space.

For information about the rules and restrictions for creating table spaces in work file databases, see [Table spaces in a work file database](#).

For information about creating large object (LOB) table spaces, see [“CREATE LOB TABLESPACE” on page 1553](#).

Db2 creates XML table spaces implicitly when you create or alter tables to add XML columns. For more information, see [XML table space implicit creation \(Db2 Administration Guide\)](#).

Invocation for CREATE TABLESPACE

This statement can be embedded in an application program or issued interactively. It is an executable statement that can be dynamically prepared only if DYNAMICRULES RUN behavior is in effect. For more information, see [“Authorization IDs and dynamic SQL” on page 94](#).

Authorization for CREATE TABLESPACE

The privilege set that is defined below must include at least one of the following:

- The CREATETS privilege for the database
- DBADM, DBCTRL, or DBMAINT authority for the database
- SYSADM or SYSCTRL authority
- System DBADM
- Installation SYSOPR authority (when the current SQLID of the process is set to SYSINSTL)

If the database is implicitly created, the database privileges must be on the implicit database or on DSNDB04.

Additional privileges might be required, as explained in the description of the BUFFERPOOL and USING STOGROUP clauses.

Privilege set: If the statement is embedded in an application program, the privilege set is the privileges that are held by the owner of the plan or package. If the application is bound in a trusted context with the ROLE AS OBJECT OWNER clause specified, a role is the owner. Otherwise, an authorization ID is the owner.

If the statement is dynamically prepared, the privilege set is the privileges that are held by the SQL authorization ID of the process unless the process is within a trusted context and the ROLE AS OBJECT OWNER clause is specified. In that case, the privileges set is the privileges that are held by the role that is associated with the primary authorization ID of the process.

Syntax for CREATE TABLESPACE

→ CREATE TABLESPACE — *table-space-name* →

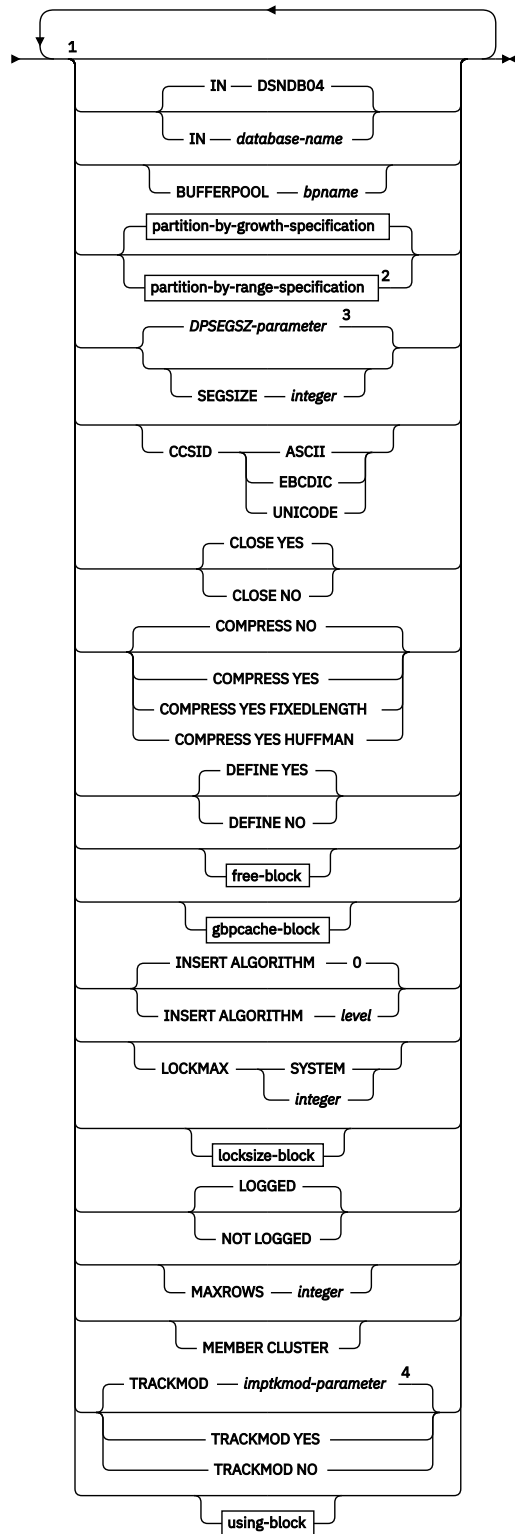

Notes:

¹ The same clause must not be specified more than one time.

² FL 504 If the CREATE TABLESPACE statement runs at application compatibility level V12R1M503 or lower, you can use deprecated specifications to create non-UTS segmented or partitioned table spaces. See [Creating non-UTS table spaces \(deprecated\)](#) (Db2 Administration Guide).

³ The default SEGSIZE value is controlled by the [DPSEGSZ subsystem parameter](#).

⁴ *imptkmod-parameter* is the IMPTKMOD subsystem parameter value. For more information, see [IMPTKMOD](#) in macro DSN6SYSP (Db2 Installation and Migration).

partition-by-growth-specification:

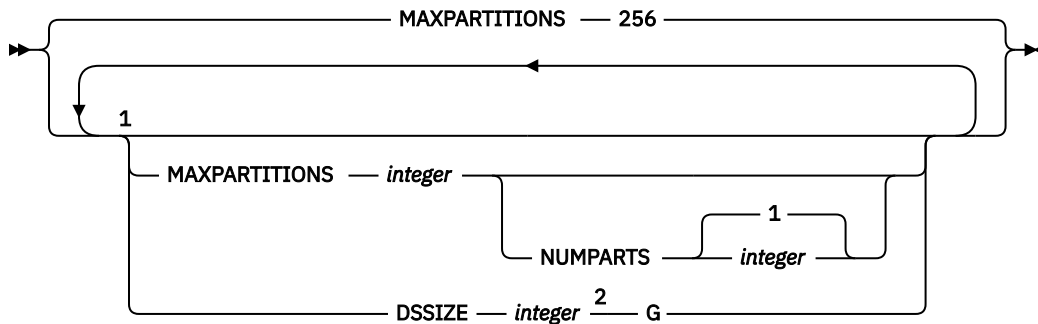

Notes:

¹ The same clause must not be specified more than one time.

² Specify a power-of-two integer in the range 1-256, or accept a default based on the MAXPARTITIONS value and the buffer pool page size. See [Table 214 on page 1725](#).

partition-by-range-specification:

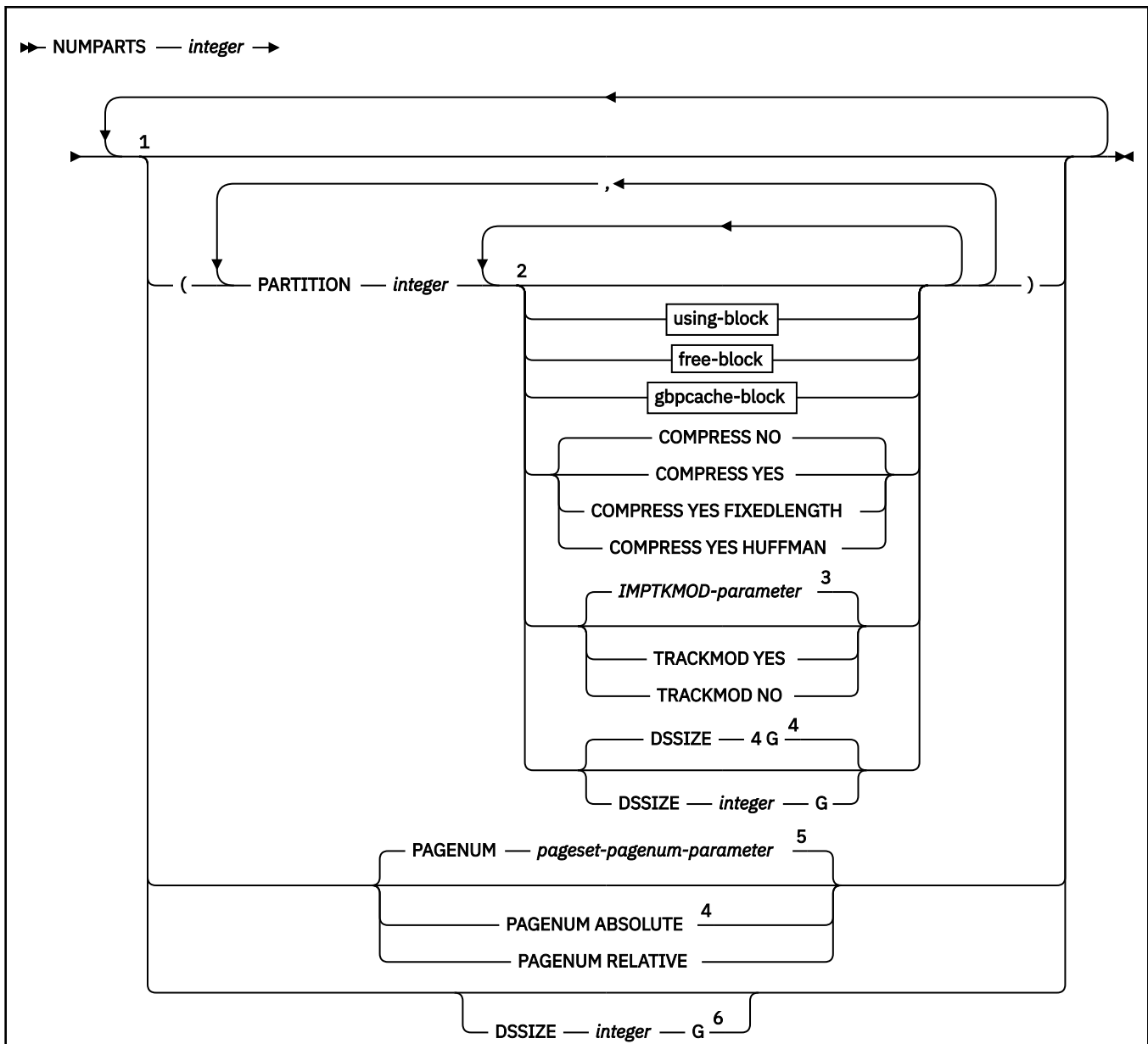

Notes:

- ¹ Group multiple PARTITION clauses. Other clauses must not be specified more than one time.
- ² The same clause must not be specified more than one time.
- ³ The IMPTKMOD subsystem parameter specified the default TRACKMOD option. For more information, see [IMPTKMOD](#) in macro DSN6SYSP (Db2 Installation and Migration).
- ⁴ DSSIZE at the partition level can be specified only if PAGENUM RELATIVE is in effect.
- ⁵ The default for PAGESET_PAGENUM is ABSOLUTE. See [PAGE SET PAGE NUMBERING](#) field (PAGESET_PAGENUM subsystem parameter) (Db2 Installation and Migration)
- ⁶ If PAGENUM RELATIVE is used, specify any integer in the range 1–1024, or accept the default value 4G. If absolute page numbers are used, specify a power-of-two integer in the range 1–256, or accept the default value based on the NUMPARTS value and the buffer pool page size. See [Table 215](#) on page 1727.

free-block:

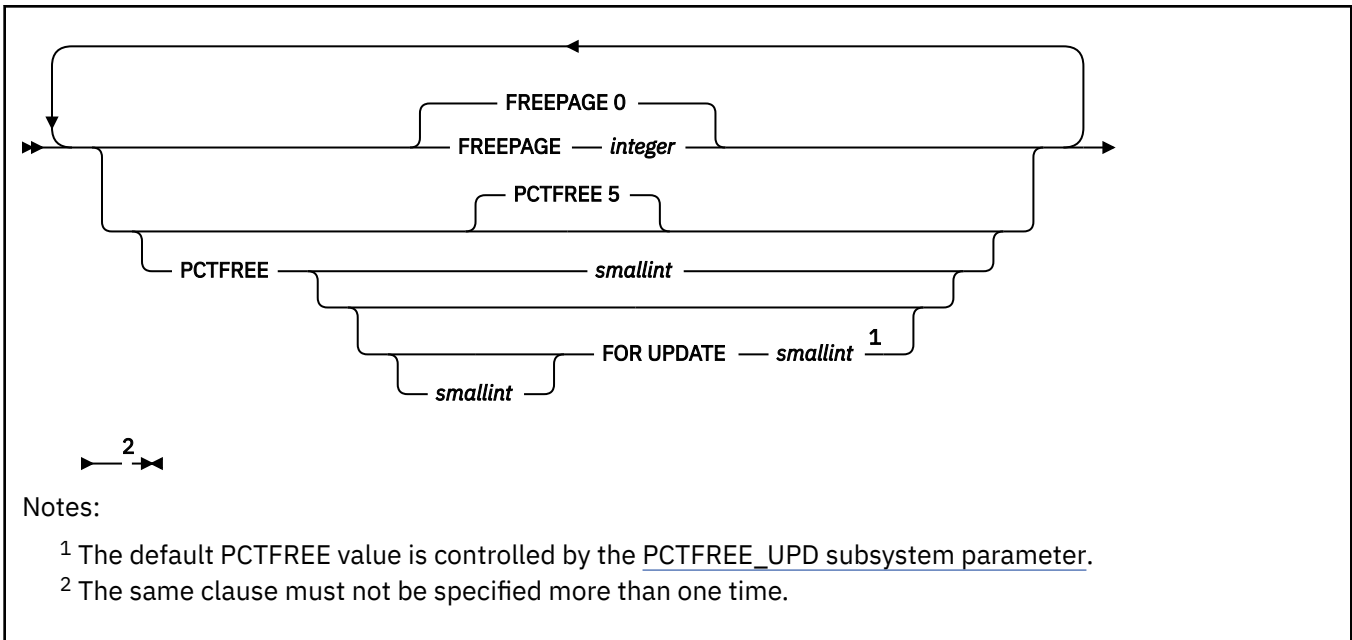

gbpcache-block:

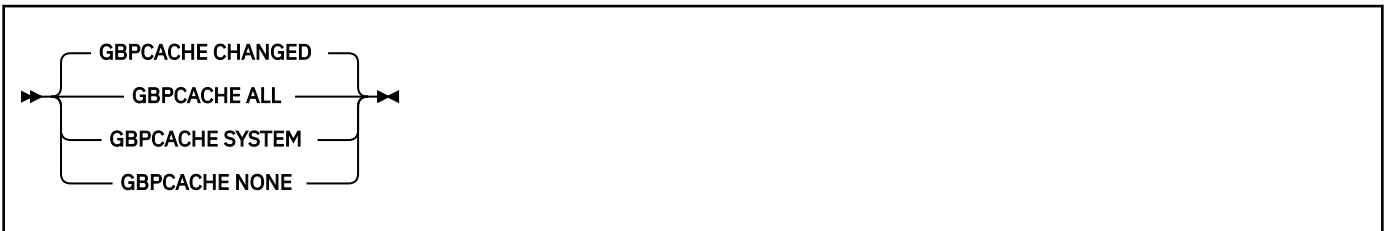

locksize-block:



using-block:

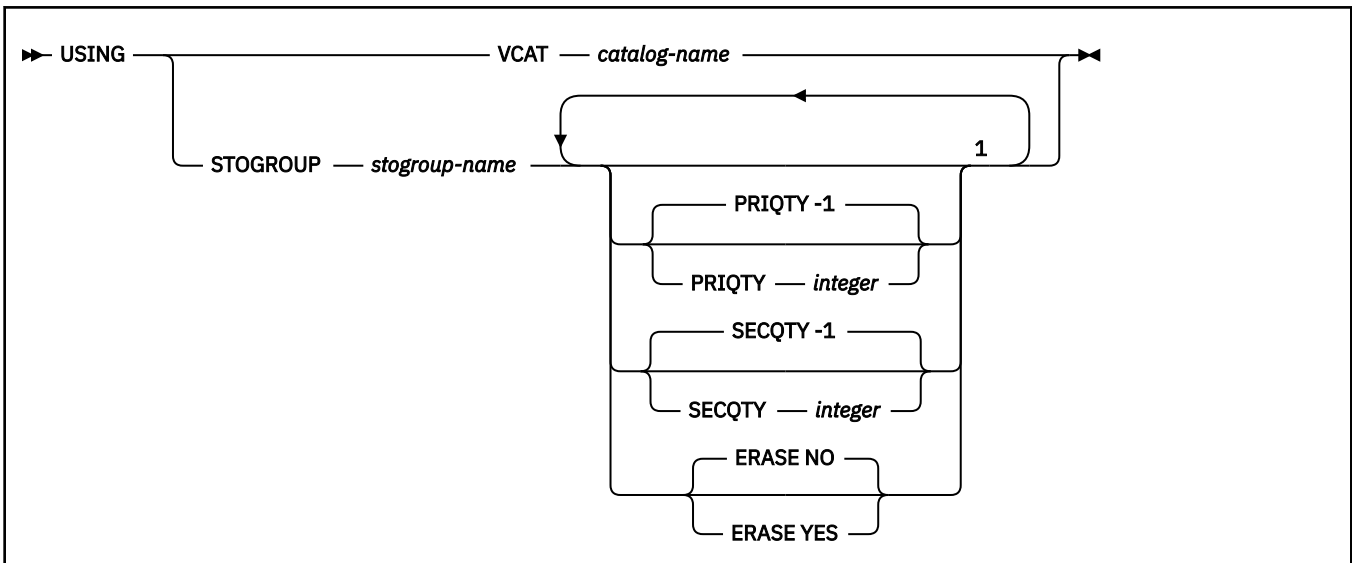

Notes:

¹ The same clause must not be specified more than one time.

Description for CREATE TABLESPACE

table-space-name

Names the table space. The name, qualified with the *database-name* implicitly or explicitly specified by the IN clause, must not identify a table space, index space, or LOB table space that exists at the current server or that exists in the SYSPENDINGOBJECTS catalog table.

A table space that is for declared temporary tables must be in the work file database. PUBLIC implicitly receives the USE privilege (without GRANT authority) on any table space created in the work file database. This implicit privilege is not recorded in the Db2 catalog, and it cannot be revoked.

IN *database-name*

Specifies the database in which the table space is created. *database-name* must identify a database that exists at the current server and must not specify the following:

- DSNDBO6
- A TEMP database
- An implicitly created database

If the table space is for declared temporary tables or static scrollable cursors, the name of the work file database must be specified.

FL 504 If *database-name* identifies a work file database, the table space must be a partition-by-growth table space.

DSNDB04 is the default.

BUFFERPOOL *bpname*

Identifies the buffer pool to be used for the table space and determines the page size of the table space. For 4KB, 8KB, 16KB and 32KB page buffer pools, the page sizes are 4 KB, 8 KB, 16 KB, and 32 KB, respectively. The *bpname* must identify an activated buffer pool, and the privilege set must include SYSADM or SYSCTRL authority, or the USE privilege on the buffer pool. If the table space is to be created in a work file database, you can specify neither 8KB buffer pools nor 16KB buffer pools.

If you do not specify the BUFFERPOOL clause, the default buffer pool of the database is used.

See “[Naming conventions in SQL](#)” on [page 79](#) for more details about *bpname*. See [-ALTER BUFFERPOOL command \(Db2\) \(Db2 Commands\)](#) for a description of active and inactive buffer pools.

The buffer pool page size affects the number of partitions that can be used. For more information, see “[Maximum number of partitions and table space size](#)” on [page 1736](#).

partition-by-growth-specification

Specifies the creation of a partition-by-growth table space. FL 504 If partition-by-growth-specification and partition-by-range-specification are both omitted, a partition-by-growth table space is created with MAXPARTITIONS 256. For a summary of clauses that control the table space type to create, see [Table space types](#).

MAXPARTITIONS *integer*

Specifies that the table space is a partition-by-growth table space.

integer specifies the maximum number of partitions to which the table space can grow. *integer* must be in the range of 1–4096, depending on the corresponding value of the DSSIZE clause.

The following table shows the maximum value for MAXPARTITIONS in relation to the page size or DSSIZE value for the table space.

Table 213. Maximum MAXPARTITIONS value for a given page size and DSSIZE value

DSSIZE value	4K page size	8K page size	16K page size	32K page size
1–4 G	4096	4096	4096	4096
8 G	2048	4096	4096	4096
16 G	1024	2048	4096	4096
32 G	512	1024	2048	4096
64 G	254	512	1024	2048
128 G	128	256	512	1024
256 G	64	128	256	512

For more information, see “Maximum number of partitions and table space size ” on page 1736.

The schema definition for the first partition is always created, and the Numparts value, if specified, controls the number of partition schema definitions to initially create and allocate data sets for. The data sets for additional partitions are not allocated until they are needed.

Although the physical data sets are not defined based on the MAXPARTITIONS value, storage and CPU overhead is possible. If an increase in the number of partitions is expected by using the MAXPARTITIONS clause, be aware that specifying a value larger than necessary, such as 4096 (the maximum value), as a default for all partition-by-growth table spaces can cause larger than expected storage requests.

NUMPARTS integer

If specified with MAXPARTITIONS, the *integer* value specifies the number of partition schema definitions to initially create. Data sets are also allocated for this many partitions, unless DEFINE NO is specified. *integer* must be a value in the range 1–4096 inclusive and must be less than or equal to the value that is specified for the MAXPARTITIONS clause.

If MAXPARTITIONS is not specified, see the Numparts clause description in “partition-by-range-specification” on page 1726.

DSSIZE integer G

Specifies the data set size in *integer* gigabytes for partitions in the table space. Each partition occupies one data set, so the data set size is also the maximum size of the partitions.

When DSSIZE is specified for a partition-by-growth table space, it must be a power-of-two integer in the range 1–256 G (1, 2, 4, 8, 16, 32, 64, 128, or 256).

integer can be separated from G by 0 or more spaces.

FL 504 If the MAXPARTITIONS clause is omitted, the default value for DSSIZE is 4G for any page size. Otherwise, the default value for DSSIZE depends on the buffer pool page size and the specified MAXPARTITIONS value as shown in the following table.

Table 214. DSSIZE defaults for partition-by-growth table spaces

Page size	MAXPARTITIONS value	DSSIZE default value
Any	1–254	4 G
4K	255–4096	4 G
8K	255–4096	8 G
16K	255–4096	16 G
32K	255–4096	32 G

For any DSSIZE value greater than 4 G, the data sets for the table space must be associated with a DFSMS data class that is specified with extended format and extended addressability.

The DSSIZE value affects the number of partitions that can be used. For more information, see [“Maximum number of partitions and table space size ” on page 1736.](#)

partition-by-range-specification

FL 504 Specifies the creation of a partition-by-range table space. For a summary of clauses that control the table space type to create, see [Table space types.](#)

NUMPARTS *integer*

If specified without MAXPARTITIONS, indicates that a partition-by-range table space is created. The *integer* value specifies the number of partitions schema definitions to create. Data sets are also allocated for this many partitions, unless DEFINE NO is also specified. *integer* must be a value in the range 1–4096 inclusive.

If MAXPARTITIONS is also specified, see the NUMPARTS clause description in [“partition-by-growth-specification” on page 1724.](#)

For table spaces created with PAGENUM RELATIVE, the maximum number of partitions is 4096. For table spaces with PAGENUM ABSOLUTE, the maximum number of partitions depends on the buffer pool page size and DSSIZE. The total table space size depends on the number of partitions and DSSIZE. For more information, see [“Maximum number of partitions and table space size ” on page 1736.](#)

PARTITION *integer*

Specifies the partition to which the following partition-level clauses apply. *integer* can range from 1 to the number of partitions given by NUMPARTS.

You can specify the PARTITION clause as many times as needed. If you use the same partition number more than once, only the last specification for that partition is used.

DSSIZE *integer* G

When specified in a PARTITION clause for a partition-by-range table space, which is supported only when PAGENUM RELATIVE is specified for the table space, specifies the data set size in *integer* gigabytes for the partition identified by PARTITION *integer*. Each partition occupies one data set, so the data set size is also the maximum size of the partition. The *integer* G value can be any value 1–1024G. The default value is 4G.

integer can be separated from G by 0 or more spaces.

PAGENUM

Identifies the type of page numbering that is used when you create a partition-by-range table space. The PAGESET_PAGENUM subsystem parameter specifies the default PAGENUM value. The default for PAGESET_PAGENUM is ABSOLUTE. See [PAGE SET PAGE NUMBERING field \(PAGESET_PAGENUM subsystem parameter\) \(Db2 Installation and Migration\).](#)

RELATIVE

Indicates that internal page numbering is kept as a 4-byte value without a partition number. The page number is a relative page from the start of the partition, and the partition number is kept only in the header page. When PAGENUM RELATIVE is specified, the data sets for the table space must be associated with a DFSMS data class that is specified with extended format and extended addressability.

ABSOLUTE

Indicates that internal page numbering is kept as a 4-byte value that includes a partition number and page number. Distinguishing which bits represent the partition and which represent the page number requires a shift value. The shift value is LOG base 2 ($DSSIZE/(page\ size)$).

DSSIZE *integer* G

Specifies the data set size in *integer* gigabytes for partitions in the table space. Each partition occupies one data set, so the data set size is also the maximum size of the partitions.

When DSSIZE is specified at the table-space level for a partition-by-range table space with PAGENUM RELATIVE, it can specify any integer value in the range 1–1024 G, and the default value is 4 G.

integer can be separated from G by 0 or more spaces.

If absolute page numbers are used, the DSSIZE value must be a power-of-two integer in the range 1–256 G (1, 2, 4, 8, 16, 32, 64, 128, or 256), and the default value depends on the Numparts value and the buffer pool page size, as shown in the following table.

integer can be separated from G by 0 or more spaces.

Table 215. DSSIZE defaults for partition-by-range table spaces with absolute page numbering

Page size	NUMPARTS value	DSSIZE default value
Any	1–16	4 G
Any	17–32	2 G
Any	33–64	1 G
Any	65–254	4 G
4K	255–4096	4 G
8K	255–4096	8 G
16K	255–4096	16 G
32K	255–4096	32 G

The DSSIZE value affects the number of partitions that can be used. For more information, see [“Maximum number of partitions and table space size”](#) on page 1736.

For any DSSIZE value greater than 4 G, the data sets for the table space must be associated with a DFSMS data class that is specified with extended format and extended addressability.

SEGSIZE *integer*

Specifies the size in pages for each segment of the table space. The *integer* value must be a multiple of 4, in the range 4–64.

If SEGSIZE is not specified, the default SEGSIZE value is controlled by the DPSEGSZ subsystem parameter. SEGSIZE 32 is used if the DPSEGSZ value is 0. Otherwise the SEGSIZE value is the DPSEGSZ value.

However, the DPSEGSZ value has no effect for a table space created in a work file database, and SEGSIZE 16 is used.

CCSID *encoding-scheme*

Specifies the encoding scheme for a table in the table space.

If you do not specify a CCSID when it is allowed, the default is the encoding scheme of the database in which the table space resides, except for table spaces in database DSNDDB04; for table spaces in DSNDDB04, the default is the value of field DEF ENCODING SCHEME on installation panel DSNTIPF.

ASCII

Specifies that the data is encoded using ASCII CCSIDs. If the database in which the table space is to reside is already defined as ASCII, the ASCII CCSIDs associated with that database are used. Otherwise, the default ASCII CCSIDs of the server are used.

EBCDIC

Specifies that the data is encoded using EBCDIC CCSIDs. If the database in which the table space is to reside is already defined as EBCDIC, the EBCDIC CCSIDs associated with that database are used. Otherwise, the default EBCDIC CCSIDs of the server are used.

An EBCDIC table in the table space can include Unicode columns.

UNICODE

Specifies that the data is encoded using the UNICODE CCSIDs of the server.

Usually, each encoding scheme requires only a single CCSID. Additional CCSIDs are needed when mixed, graphic, or Unicode data is used.

All data stored within a table space must use the same encoding scheme unless the table space is in a work file database.

CLOSE

When the limit on the number of open data sets is reached, specifies the priority in which data sets are closed.

YES

Eligible for closing before CLOSE NO data sets. CLOSE YES is the default value, unless the table space is in a work file database.

NO

Eligible for closing after all eligible CLOSE YES data sets are closed.

COMPRESS

Specifies whether data compression applies to the rows of the table space or a partition in the table space.

For partitioned table spaces, the COMPRESS attribute for a partition is determined from the first of the following conditions that apply to the CREATE statement:

- The value specified in the COMPRESS clause in the PARTITION clause for that partition
- The value specified in the COMPRESS clause that is not in any PARTITION clause
- Otherwise, COMPRESS NO is the default for the partition

For more information about data compression, see [Compressing your data \(Db2 Performance\)](#).

YES

[FL 509](#) Specifies that data compression is used for the table space or partition. The rows are not compressed until the LOAD or REORG utility is run on a table in the table space or on a partition, or until the total row data size reaches the compression data threshold while an insert operation is performed.

If a keyword for the compression algorithm is not specified, the default compression algorithm is used. The data compression algorithm is determined by the TS_COMPRESSION_TYPE subsystem parameter.

If a keyword for the compression algorithm is specified:

- LOB table spaces that are implicitly created for LOB columns in this table space are defined as if COMPRESS YES has been specified without a compression algorithm. LOB compression is managed by zEDC hardware if available.
- XML table spaces that are implicitly created for XML columns in this table space inherit the compression attribute.

FIXEDLENGTH

[FL 509](#) Specifies the fixed-length data compression algorithm.

HUFFMAN

[FL 509](#) Specifies the Huffman data compression algorithm. See [Using Huffman compression to compress your data \(Db2 Performance\)](#) for requirements to enable Huffman compression.

NO

Specifies no data compression for the table space or partition. Inserted rows are not compressed.

DEFINE

Specifies when the underlying data sets for the table space are physically allocated.

YES

The data sets are created when the table space is created (the CREATE TABLESPACE statement is executed). YES is the default.

NO

The data sets are not created until data is inserted into the table space. DEFINE NO is applicable only for Db2-managed data sets (USING STOGROUP is specified). DEFINE NO is ignored for user-managed data sets (USING VCAT is specified). Db2 uses the SPACE column in catalog table SYSTABLEPART to record the status of the data sets (undefined or allocated).

DEFINE NO is not recommended if you intend to use any tools outside of Db2 to manipulate data, such as to load data, because data sets might then exist when Db2 does not expect them to exist. When Db2 encounters this inconsistent state, applications will receive an error.

For table spaces that are created with DEFINE NO, point-in-time recover will not work before data sets exist and before a recovery copy exists.

free-block

Specifies how to leave free space when the table space is loaded or reorganized.

FREEPAGE *integer*

Specifies how often to leave a page of free space when the table space or partition is loaded or reorganized. You must specify an integer in the range 0–255. If you specify 0, no pages are left as free space. Otherwise, one free page is left after every *n* pages, where *n* is the specified *integer* value. The number of pages left must be less than the segment size. If the integer you specify is not less than the segment size, *n* is one less than the segment size.

The default is FREEPAGE 0, leaving no free pages.

For more information, see:

[Reserving free space in table spaces \(Db2 Performance\)](#)

[Reserving free spaces for indexes \(Db2 Performance\)](#)

PCTFREE *smallint*

Indicates what percentage of each page to leave as free space when the table is loaded or reorganized. *smallint* is in the range 0–99. The first record on each page is loaded without restriction. When additional records are loaded, at least *smallint* percent of free space is left on each page.

The default is PCTFREE 5, which means that 5% of the space on each page is reserved as free space.

FOR UPDATE *smallint*

Specifies the percentage of space to reserve as free space on each page, for use by subsequent update operations. The *smallint* value is an integer in the range -1 to 99. FOR UPDATE -1 specifies that 5% of free space is reserved initially, and the amount of free space is calculated automatically based on certain real-time statistics values. The first record on each page is always loaded without restriction.

An update operation might use more space, if it is available, than is specified by the PCTFREE or PCTFREE FOR UPDATE options.

The default FOR UPDATE value is controlled by the [PCTFREE_UPD subsystem parameter](#).

The value is recorded in the PCTFREE_UPD column of the SYSIBM.SYSTABLEPART catalog table.

The sum of the values for PCTFREE *smallint* and FOR UPDATE *smallint* must be less than or equal to 99.

For more information, see:

[Reserving free space in table spaces \(Db2 Performance\)](#)

[Reserving free spaces for indexes \(Db2 Performance\)](#)

gbpcache-block

In a data sharing environment, specifies which pages of the table space or partition are written to the group buffer pool. In a non-data-sharing environment, you can specify GBPCACHE for a table space, but it is ignored. However, do not specify GBPCACHE for a table space in a work file database in either environment (data sharing or non-data-sharing).

GBPCACHE

Specifies pages of the table space or partition are written to the group buffer pool.

CHANGED

When there is inter-Db2 R/W interest on the table space or partition, updated pages are written to the group buffer pool. When there is no inter-Db2 R/W interest, the group buffer pool is not used. Inter-Db2 R/W interest exists when more than one member in the data sharing group has the table space or partition open, and at least one member has it open for update. GBPCACHE CHANGED is the default.

If the table space is in a group buffer pool that is defined to be used only for cross-invalidation (GBPCACHE NO), CHANGED is ignored and no pages are cached to the group buffer pool.

ALL

Indicates that pages are to be cached in the group buffer pool as they are read in from DASD.

Exception: In the case of a single updating Db2 when no other DB2s have any interest in the page set, no pages are cached in the group buffer pool.

If the table space is in a group buffer pool that is defined to be used only for cross-invalidation (GBPCACHE NO), ALL is ignored and no pages are cached to the group buffer pool.

NONE

Indicates that no pages are to be cached to the group buffer pool. Db2 uses the group buffer pool only for cross-invalidation.

If you specify NONE, the table space or partition must not be in recover pending status and must be in the stopped state when the CREATE TABLESPACE statement is executed.

The value of GBPCACHE for a particular partition is determined by the first of these choices that applies:

1. The GBPCACHE specified in the PARTITION clause for the partition. Do not use more than one *gbpcache-block* in any PARTITION clause.
2. The value specified in a *gbpcache-block* for the table space.
3. The default value CHANGED.

INSERT ALGORITHM level

Specifies the algorithm that is used when rows are inserted into tables in this table space. The insert algorithm level is used only where applicable when MEMBER CLUSTER is specified. The default value is 0.

0

Specifies that the insert algorithm level is determined by the DEFAULT_INSERT_ALGORITHM subsystem parameter at the time a row is inserted.

1

Specifies that the basic insert algorithm is used.

2

Specifies that insert algorithm 2 is used.

LOCKMAX

Specifies the maximum number of page or row locks an application process can hold simultaneously in the table space. If a program requests more than that number, locks are

escalated. The page or row locks are released and the intent lock on the table space is promoted to S or X mode.

integer

Specifies the number of locks allowed before escalating, in the range 0–2147483647.

Zero (0) indicates that the number of locks on the table or table space are not counted and escalation does not occur.

SYSTEM

FL 507 Specifies that Db2 determines the maximum number of locks that a program can hold simultaneously in the table space from the SYSIBMADM.MAX_LOCKS_PER_TABLESPACE built-in global variable.

For more information see [“MAX_LOCKS_PER_TABLESPACE” on page 331](#).

The following table summarizes the results of specifying a LOCKSIZE value while omitting LOCKMAX.

LOCKSIZE	Resultant LOCKMAX
ANY	SYSTEM
TABLESPACE, PAGE, ROW	0

If the lock size is TABLESPACE, LOCKMAX must be omitted, or its operand must be 0.

locksize-block

Specifies the size of locks used for the table space, and thresholds for lock escalation in some cases.

LOCKSIZE

Specifies the size of locks used within the table space and, in some cases, also the threshold at which lock escalation occurs.

ANY

Specifies that Db2 can use any lock size.

FL 507In most cases, Db2 uses LOCKSIZE PAGE LOCKMAX SYSTEM. However, when the number of locks acquired for the table space exceeds the maximum number of locks allowed for a table space (the value of the SYSIBMADM.MAX_LOCKS_PER_TABLESPACE built-in global variable), the page locks are released and partition level locks are used. For more information see [“MAX_LOCKS_PER_TABLESPACE” on page 331](#).

TABLESPACE

Specifies table space locks.

PAGE

Specifies page locks.

ROW

Specifies row locks.

LOGGED or NOT LOGGED

Specifies whether changes that are made to the data in the specified table space are recorded in the log. LOGGED and NOT LOGGED cannot be specified for table spaces in database DSNDB06, which contains the Db2 catalog. This setting applies to the table that is created in the specified table space and to all indexes of the table. XML table spaces and their indexes inherit the logging attribute from the associated base table space. Auxiliary indexes also inherit the logging attribute from the associated base table space.

LOGGED

Specifies that changes that are made to the data in the specified table space are recorded in the log.

LOGGED is the default.

NOT LOGGED

Specifies that changes that are made to data in the specified table space are not recorded in the log.

NOT LOGGED prevents undo and redo information from being recorded in the log; however, control information for the specified table space will continue to be recorded in the log.

MAXROWS *integer*

Specifies the maximum number of rows that Db2 will consider placing on each data page. The integer can range 1–255. This value is considered for insert operations, LOAD, and REORG. For LOAD and REORG, the PCTFREE specification is considered before MAXROWS; therefore, fewer rows might be stored than the value you specify for MAXROWS.

If you do not specify MAXROWS, the default number of rows is 255.

MEMBER CLUSTER

Specifies that data inserted by an insert operation is not clustered by the implicit clustering index (the first index) or the explicit clustering index. Instead, Db2 chooses where to locate the data in the table space based on available space.

TRACKMOD

Specifies whether Db2 tracks modified pages in the space map pages.

YES

Db2 tracks changed pages in the space map pages to improve the performance of incremental image copy.

NO

Db2 does not track changed pages in the space map pages. It uses the LRSN value in each page to determine whether a page has been changed.

The TRACKMOD clause can be specified for each partition, or for the table space. If the TRACKMOD value is not specified for a partition, the TRACKMOD value for the table space is used. If the TRACKMOD value for the table space is not specified, the default value specified by the IMPTKMOD subsystem parameter is used. For more information, see [IMPTKMOD in macro DSN6SYSP \(Db2 Installation and Migration\)](#).

using-block

Specifies whether Db2 or the user manages the data sets for the table space or its partitions. The USING clause can be specified for each partition or for the table space. If the USING clause is not specified for a partition, the USING clause specified for the table space is used. If the USING clause is not specified for the table space, the storage group of the database is used, with the normal defaults for PRIQTY, SECQTY, and ERASE. If the USING clause for the table space is omitted, the default storage group for database must exist.

VCAT *catalog-name*

Indicates that the data set for the partition is managed by the user using the naming conventions set forth in [Data set naming conventions \(Db2 Administration Guide\)](#). As was true for the nonpartitioned case, *catalog-name* identifies the catalog for the data set and supplies the first-level qualifier for the data set name.

One or more Db2 subsystems could share integrated catalog facility catalogs with the current server. To avoid the chance of having one of those subsystems attempt to assign the same name to different data sets, select a value for *catalog-name* that is not used by the other Db2 subsystems.

USING VCAT must not be specified for a partition-by-growth table space.

Db2 assumes one and only one data set for each partition.

STOGROUP *stogroup-name*

Indicates that Db2 will create a data set for the partition with the aid of a storage group named *stogroup-name*. The data set is defined during the execution of this statement. Db2 assumes one and only one data set for each partition.

The *stogroup-name* must identify a storage group that exists at the current server and the privilege set must include SYSADM authority, SYSCTRL authority, or the USE privilege for the storage group. The integrated catalog facility catalog used for the storage group must not contain an entry for that data set.

When USING STOGROUP is specified for a partition, the defaults for PRIQTY, SECQTY, and ERASE are the values specified in the USING STOGROUP clause that is not in any PARTITION clause. If that USING STOGROUP clause is not specified, the defaults are those specified in the description of PRIQTY, SECQTY, and ERASE.

PRIQTY *integer*

Specifies the minimum primary space allocation for a Db2-managed data set. *integer* must be a positive integer, or -1. In general, when you specify PRIQTY with a positive integer value, the primary space allocation is at least *n* kilobytes, where *n* is the value of *integer*. However, the following exceptions exist:

- For 4KB page sizes, if *integer* is greater than 0 and less than 200, *n* is 200.
- For 8KB page sizes, if *integer* is greater than 0 and less than 400, *n* is 400.
- For 16KB page sizes, if *integer* is greater than 0 and less than 800, *n* is 800.
- For 32KB page sizes, if *integer* is greater than 0 and less than 1600, *n* is 1600.
- For any page size, if *integer* is greater than 67108864, *n* is 67108864.

If you do not specify PRIQTY, or specify PRIQTY with a value of -1, Db2 uses a default value for the primary space allocation; for information on how Db2 determines the default value, see [Rules for primary and secondary space allocation \(Introduction to Db2 for z/OS\)](#).

If you specify PRIQTY, and do not specify a value of -1, Db2 specifies the primary space allocation to access method services using the smallest multiple of *p* KB not less than *n*, where *p* is the page size of the table space. The allocated space can be greater than the amount of space requested by Db2. For example, it could be the smallest number of tracks that will accommodate the request. The amount of storage space requested must be available on some volume in the storage group based on VSAM space allocation restrictions. Otherwise, the primary space allocation will fail. To more closely estimate the actual amount of storage, see [DEFINE CLUSTER command \(DFSMS Access Method Services for Catalogs\)](#).

Executing this statement causes only one data set to be created. However, you might have more data than this one data set can hold. Db2 automatically defines more data sets when they are needed. Regardless of the value in PRIQTY, when a data set reaches its maximum size, Db2 creates a new one. To enable a data set to reach its maximum size without running out of extents, it is recommended that you allow Db2 to automatically choose the value of the secondary space allocations for extents.

If you do choose to explicitly specify SECQTY, to avoid wasting space, use the following formula to make sure that PRIQTY and its associated secondary extent values do not exceed the maximum size of the data set:

```
PRIQTY + (number of extents * SECQTY) <= DSSIZE (implicit or explicit)
```

SECQTY *integer*

Specifies the minimum secondary space allocation for a Db2-managed data set. *integer* must be a positive integer, 0, or -1. If you do not specify SECQTY, or specify SECQTY with a value of -1, Db2 uses a formula to determine a value. For information on the actual value that is used for secondary space allocation, whether you specify a value or not, see [Rules for primary and secondary space allocation \(Introduction to Db2 for z/OS\)](#).

If you specify SECQTY, and do not specify a value of -1, Db2 specifies the secondary space allocation to access method services using the smallest multiple of p KB not less than *integer*, where p is the page size of the table space. The allocated space can be greater than the amount of space requested by Db2. For example, it could be the smallest number of tracks that will accommodate the request. To more closely estimate the actual amount of storage, see [DEFINE CLUSTER command \(DFSMS Access Method Services for Catalogs\)](#).

ERASE

Indicates whether the Db2-managed data sets for the table space are to be erased when they are deleted during the execution of a utility or an SQL statement that drops the table space.

NO

Does not erase the data sets. Operations involving data set deletion will perform better than ERASE YES. However, the data is still accessible, though not through Db2. This is the default.

YES

Erases the data sets. As a security measure, Db2 overwrites all data in the data sets with zeros before they are deleted.

Notes for CREATE TABLESPACE

Table space types

FL 504 In application compatibility level V12R1M504 and higher, the type of partitioning of the resulting table space depends on whether the CREATE TABLESPACE statement specifies the MAXPARTITIONS clause and Numparts clauses, as shown in the following table. If the CREATE TABLESPACE statement specifies the Numparts clause but no MAXPARTITIONS clause, the result is a partition-by-range table space. Otherwise, the result is a partition-by-growth table space.

However, below application compatibility level V12R1M504, deprecated table space types including segmented (non-UTS) and partitioned (non-UTS) table spaces can be created. In such cases, the type of table space created depends on the SEGSIZE, MAXPARTITIONS, and Numparts clauses that the CREATE TABLESPACE statement specifies.

Table 216. CREATE TABLESPACE clauses for specifying table space types, by application compatibility level.

Table space type	APPLCOMPAT(V12R1M504) and higher	APPLCOMPAT(V12R1M503) and lower
Partition-by-growth	Any of the following combinations: <ul style="list-style-type: none"> • MAXPARTITIONS and Numparts • MAXPARTITIONS • Omit both 	Any of the following combinations: <ul style="list-style-type: none"> • MAXPARTITIONS and Numparts • MAXPARTITIONS and SEGSIZE n ^{"1" on page 1735} • MAXPARTITIONS
Partition-by-range	Numparts only	Numparts and SEGSIZE n ^{"1" on page 1735}
Segmented (non-UTS)	Not supported ^{"2" on page 1735}	One of the following combinations: <ul style="list-style-type: none"> • SEGSIZE n ^{"1" on page 1735} • Omit MAXPARTITIONS, Numparts, and SEGSIZE
Partitioned (non-UTS)	Not supported ^{"2" on page 1735}	Numparts and SEGSIZE 0

Table 216. CREATE TABLESPACE clauses for specifying table space types, by application compatibility level. (continued)

Table space type	APPLCOMPAT(V12R1M504) and higher	APPLCOMPAT(V12R1M503) and lower
------------------	----------------------------------	---------------------------------

Notes:

1. Where *n* is a non-zero value. The DPSEGSZ subsystem parameter determines the default value. For more information, see [DEFAULT PARTITION SEGSIZE field \(DPSEGSZ subsystem parameter\) \(Db2 Installation and Migration\)](#).
2. FL 504 Non-UTS table spaces for base tables are deprecated. CREATE TABLESPACE statements that run at application compatibility level V12R1M504 or higher always create a partition-by-growth or partition-by-range table space, and CREATE TABLE statements that specify a non-UTS table space (including existing multi-table segmented table spaces) return an error. However, you can use a lower application compatibility level to create table spaces of the deprecated types if needed, such as for recovery situations. For instructions, see [Creating non-UTS table spaces \(deprecated\) \(Db2 Administration Guide\)](#).

DSSIZE value greater than 4 G

For any DSSIZE value greater than 4 G, the data sets for the table space must be associated with a DFMS data class that is specified with extended format and extended addressability.

FL 504 XML table spaces

If a partition-by-growth table space contains an XML column, the corresponding XML table space is a partition-by-growth table space that grows independently of the base table space. If a partition-by-range table space contains an XML column, the corresponding XML table space is a partition-by-range table space that is data partitioned. That is, it is partitioned according to the partitioning scheme of the base table data.

Applications that use currently committed access with table spaces that specify LOCKSIZE PAGE

To ensure that readers of data in a table space that is defined with LOCKSIZE PAGE can always access currently committed data, set MAXROWS to 8 or less. If MAXROWS is greater than 8, readers might need to wait for insert or delete operations on tables in the table space to commit before the readers can access rows in the tables.

For more information, see [Accessing currently committed data to avoid lock contention \(Db2 Performance\)](#).

Table spaces in a work file database

[FL 504A](#) table space in a work file database is always a partition-by-growth table space.

The following restrictions apply to table spaces created in a work file database:

- They can be created for another member only if both the executing Db2 subsystem and the other member can access the work file data sets. That is required whether the data sets are user-managed or in a Db2 storage group.
- They cannot use 8 KB or 16 KB page sizes. (The buffer pool in which you define the table space determines the page size. For example, a table space that is defined in a 4 KB buffer pool has 4 KB page sizes.)
- When you create a table space in a work file database, the following clauses are not allowed:

CCSID
 COMPRESS
 CLOSE YES
 DEFINE NO
 FREEPAGE
 GBPCACHE
 LARGE
 LOCKPART
 LOCKSIZE

LOGGED
 MAXROWS
 MEMBER CLUSTER
 NOT LOGGED
 PAGENUM
 PCTFREE
 SEGSIZE (SEGSIZE 16 is always used)
 TRACKMOD

Table spaces for declared temporary tables

Declared temporary tables and sensitive static scrollable cursors must reside in table spaces in the work file database. At least one table space with a 32 KB page size must exist in the work file database before a declared temporary table can be defined and used or before sensitive static scrollable cursors are opened.

Table spaces in the work file database are shared by work files, created and declared global temporary tables and sensitive static scrollable cursor result tables. You cannot specify which table space is to be used for any specific object.

Table space row formats

All newly created table spaces use re-ordered row format.

Rules for primary and secondary space allocation

You can specify the primary and secondary space allocation or let Db2 choose them. Having Db2 choose the values, especially the secondary space quantity, increases the possibility of reaching the maximum data set size before running out of extents. For more information, see [Rules for primary and secondary space allocation \(Introduction to Db2 for z/OS\)](#).

Maximum number of partitions and table space size

For partition-by-range table spaces created with relative page numbering, the maximum number of partitions is 4096. For partition-by-range table spaces with absolute page numbering or partition-by-growth table spaces, the following tables show how the maximum number of partitions and the total table space size depend on the buffer pool page size and DSSIZE value, with 5-byte extended addressability (EA) storage. ^{“1” on page 1738}

4 KB page size

Table 217. Maximum number of partitions and table space size by DSSIZE, with 4 KB page size

DSSIZE	Maximum number of partitions	Total table space size
1G	4096	4 TB
2G	4096	8 TB
4G	4096	16 TB
8G	2048	16 TB
16G	1024	16 TB
32G	512	16 TB
64G	256	16 TB
128G	128	16 TB
256G	64	16 TB

8 KB page size

Table 218. Maximum number of partitions and table space size by DSSIZE, with 8 KB page size

DSSIZE	Maximum number of partitions	Total table space size
1G	4096	4TB
2G	4096	8TB
4G	4096	16TB
8G	4096	32TB
16G	2048	32TB
32G	1024	32TB
64G	512	32TB
128G	256	32TB
256G	128	32TB

16 KB page size

Table 219. Maximum number of partitions and table space size by DSSIZE, with 16 KB page size

DSSIZE	Maximum number of partitions	Total table space size
1G	4096	4 TB
2G	4096	8 TB
4G	4096	16 TB
8G	4096	32 TB
16G	4096	64 TB
32G	2048	64 TB
64G	1024	64 TB
128G	512	64 TB
256G	256	64 TB

32 KB page size

Table 220. Maximum number of partitions and table space size by DSSIZE, with 32 KB page size

DSSIZE	Maximum number of partitions	Total table space size
1G	4096	4 TB
2G	4096	8 TB
4G	4096	16 TB
8G	4096	32 TB
16G	4096	64 TB
32G	4096	128 TB
64G	2048	128 TB

Table 220. Maximum number of partitions and table space size by DSSIZE, with 32 KB page size (continued)

DSSIZE	Maximum number of partitions	Total table space size
128G	1024	128 TB
256G	512	128 TB

Notes:

1. For 5-byte non-EA storage, the maximum values for 4 KB page size are DSSIZE 4 G, 4096 partitions, and 16 TB for total table space.

Alternative syntax and synonyms

For compatibility with previous Db2 releases or function levels, the following keywords are supported:

- You can specify the LOCKPART clause, but it has no effect. Db2 treats all table spaces as if they were defined as LOCKPART YES. LOCKPART YES specifies the use of selective partition locking. When all the conditions for selective partition locking are met, Db2 locks only the partitions that are accessed. When the conditions for selective partition locking are not met, Db2 locks every partition of the table space.

LOCKSIZE TABLESPACE and LOCKPART YES are mutually exclusive.

- When creating a partitioned table space, you can specify PART as a synonym for PARTITION.
- When specifying the logging attributes for a table space, you can specify LOG YES as a synonym for LOGGED, and you can specify LOG NO as a synonym for NOT LOGGED.
- DSSIZE is the preferred clause for specifying the partition size, however you can specify the CREATE LARGE TABLESPACE when creating partitioned table spaces.
- [FL 504](#) If neither MAXPARTITIONS nor Numparts is specified, you can specify LOCKSIZE TABLE as a synonym for LOCKSIZE TABLESPACE.

Although these keywords are supported as alternatives, they are not the preferred syntax.

Examples for CREATE TABLESPACE

Example 1: using a storage group for a partition-by-growth table space

Create a table space DSN8S12D in database DSN8D12A. Let Db2 define the data sets, using storage group DSN8G120. The primary space allocation is 52 kilobytes; the secondary, 20 kilobytes. The data sets need not be erased before they are deleted.

Locking on tables in the space is to take place at the page level. Associate the table space with buffer pool BP1. The data sets can be closed when no one is using the table space.

```
CREATE TABLESPACE DSN8S12D
  IN DSN8D12A
  USING STOGROUP DSN8G120
  PRIQTY 52
  SECQTY 20
  ERASE NO
  LOCKSIZE PAGE
  BUFFERPOOL BP1
  CLOSE YES;
```

For the above example, the underlying data sets for the table space will be created immediately, which is the default (DEFINE YES). If you want to defer the creation of the data sets until data is first inserted into the table space, you would specify DEFINE NO instead of accepting the default behavior.

[FL 504](#) Because the CREATE TABLESPACE statement omits the Numparts and MAXPARTITIONS clauses, the resulting table spaces is a partition-by-growth table space.

Example 2: partition options for a partition-by-range table space

Assume that a large query database application uses a table space to record historical sales data for marketing statistics. Create large table space SALESX in database DSN8D12A for the application. Create it with 82 partitions, specifying that the data in partitions 80–82 is to be compressed.

Let Db2 define the data sets for all the partitions in the table space, using storage group DSN8G120. For each data set, the primary space allocation is 4000 kilobytes, and the secondary space allocation is 130 kilobytes. Except for the data set for partition 82, the data sets do not need to be erased before they are deleted.

Locking on the table is to take place at the page level. There can only be one table in a partitioned table space. Associate the table space with buffer pool BP1. The data sets cannot be closed when no one is using the table space. If there are no CLOSE YES data sets to close, Db2 might close the CLOSE NO data sets when the DSMAX is reached.

```
CREATE TABLESPACE SALESX
  IN DSN8D12A
  USING STOGROUP DSN8G120
  PRIQTY 4000
  SECQTY 130
  ERASE NO
  NUMPARTS 82
  (PARTITION 80
   COMPRESS YES,
   PARTITION 81
   COMPRESS YES,
   PARTITION 82
   COMPRESS YES
   USING STOGROUP DSN8G120
   ERASE YES)
  LOCKSIZE PAGE
  BUFFERPOOL BP1
  CLOSE NO;
```

FL 504 Because the CREATE TABLESPACE statement specifies a NUMPARTS clause and no MAXPARTITIONS clause, a partition-by-range table space is created.

Example 3: partition-by-range table space

The following example creates a partition-by-range table space, TS1, in database DSN8D12A using storage group DSN8G120. The table space has 16 pages per segment and has 55 partitions. It specifies LOCKSIZE ANY.

```
CREATE TABLESPACE TS1
  IN DSN8D12A
  USING STOGROUP DSN8G120
  NUMPARTS 55
  SEGSIZE 16
  LOCKSIZE ANY;
```

Example 4: partition-by-range table space

The following example creates a partition-by-range table space, TS2, in database DSN8D12A using storage group DSN8G120. The table space has 64 pages per segment and has seven defer-defined partitions, where every other partition is compressed.

```
CREATE TABLESPACE TS2
  IN DSN8D12A
  USING STOGROUP DSN8G120
  NUMPARTS 7
  (
   PARTITION 1 COMPRESS YES,
   PARTITION 3 COMPRESS YES,
   PARTITION 5 COMPRESS YES,
   PARTITION 7 COMPRESS YES
  )
  SEGSIZE 64
  DEFINE NO;
```

Example 5: partition-by-growth table space

The following example creates a partition-by-growth table space that has a maximum size of 2 GB for each partition, four pages per segment with a maximum of 24 partitions for the table space.

```
CREATE TABLESPACE TS01TS IN TS01DB USING STOGROUP SG1
DSSIZE 2G
MAXPARTITIONS 24
LOCKSIZE ANY
SEGSIZE 4;
```

Related concepts

[Db2 table spaces \(Introduction to Db2 for z/OS\)](#)

[Table space types and characteristics in Db2 for z/OS \(Db2 Administration Guide\)](#)

[Naming conventions](#)

The rules for forming a name depend on the type of the object designated by the name.

Related information

[Implementing Db2 table spaces \(Db2 Administration Guide\)](#)

CREATE TRIGGER statement (advanced trigger)

The CREATE TRIGGER (advanced) statement defines an advanced trigger in a schema and builds a trigger package at the current server. Each time that the trigger activates, the trigger package executes one or more times.

For a description of the differences between basic and advanced triggers, see [Triggers \(Introduction to Db2 for z/OS\)](#).

Invocation for CREATE TRIGGER (advanced)

This statement can be issued interactively. It is an executable statement that can be dynamically prepared only if DYNAMICRULES RUN behavior is in effect. For more information, see [“Authorization IDs and dynamic SQL”](#) on page 94.

Authorization for CREATE TRIGGER (advanced)

To create a new trigger in the implicit or explicit schema, the privilege set that is defined below must include at least one of the following:

- The CREATEIN privilege on the schema
- System DBADM authority
- SYSCTRL authority
- SYSADM authority
- Installation SYSOPR authority (when the current SQLID of the process is set to SYSINSTL)

To replace a trigger, the privilege set that is defined below must include at least one of the following:

- Ownership of the trigger
- DATAACCESS authority and DROPIN and CREATEIN privilege on the schema
- SYSADM authority

Additionally, to create or replace an existing trigger for a table, the privilege set that is defined below must include at least one of the following:

- The TRIGGER privilege on the table on which the trigger is defined
- The ALTER privilege on the table on which the trigger is defined
- DBADM authority on the database that contains the table
- System DBADM authority
- SYSCTRL authority

- SYSADM authority
- Installation SYSOPR authority (when the current SQLID of the process is set to SYSINSTL)

If the database is implicitly created, the database privileges must be on the implicit database or on DSNDBO4.

Additionally, to create or replace an existing trigger for a view, the privilege set that is defined below must include at least one of the following:

- Ownership of the view on which the trigger is defined
- System DBADM authority
- SYSCTRL authority
- SYSADM authority

To add or replace a version of an existing trigger, the privilege set that is defined below must include at least one of the following:

- Ownership of the trigger
- DATAACCESS authority and ALTERIN on the schema
- SYSADM authority

Additional privileges might be needed for the following:

- To execute the body of the trigger, the owner of the trigger must have SYSADM authority, or each of the following:
 - The SELECT privilege on the table on which the trigger is defined
 - The SELECT privilege on any table or view that is referenced in the *search-condition* of the *triggered-action*
 - The privileges that are required to execute the statements in *SQL-trigger-body*
- If the SECURED option is specified, either SECADM authority or the CREATE_SECURE_OBJECT privilege is needed.

Note: If the SEPARATE SECURITY subsystem parameter is set to NO, SYSADM authority has implicit SECADM authority.

- If the WLM ENVIRONMENT FOR DEBUG MODE clause is specified, RACF or an external security product is invoked to check the required authority for defining programs in the WLM environment. If the WLM environment access is protected in RACF, the user that issued the CREATE statement must have the required authority. For more information, see [Managing authorizations for creation of stored procedures in WLM environments \(Managing Security\)](#).
- Additional authorization might be required on the SYSDUMMYx tables depending on the content of the trigger definition. See [SYSDUMMYx tables](#).

Privilege set: The privilege set is the privileges that are held by the SQL authorization ID of the process unless the process is within a trusted context and the ROLE AS OBJECT OWNER clause is specified. In that case, the privilege set is the privileges that are held by the role that is associated with the primary authorization ID of the process and the owner is that role.

Syntax for CREATE TRIGGER (advanced)

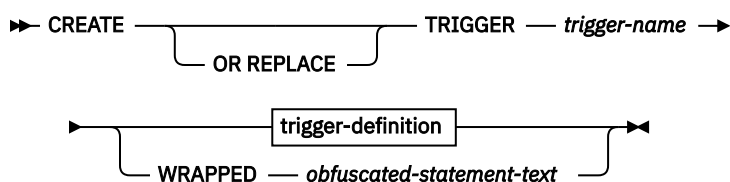

trigger-definition

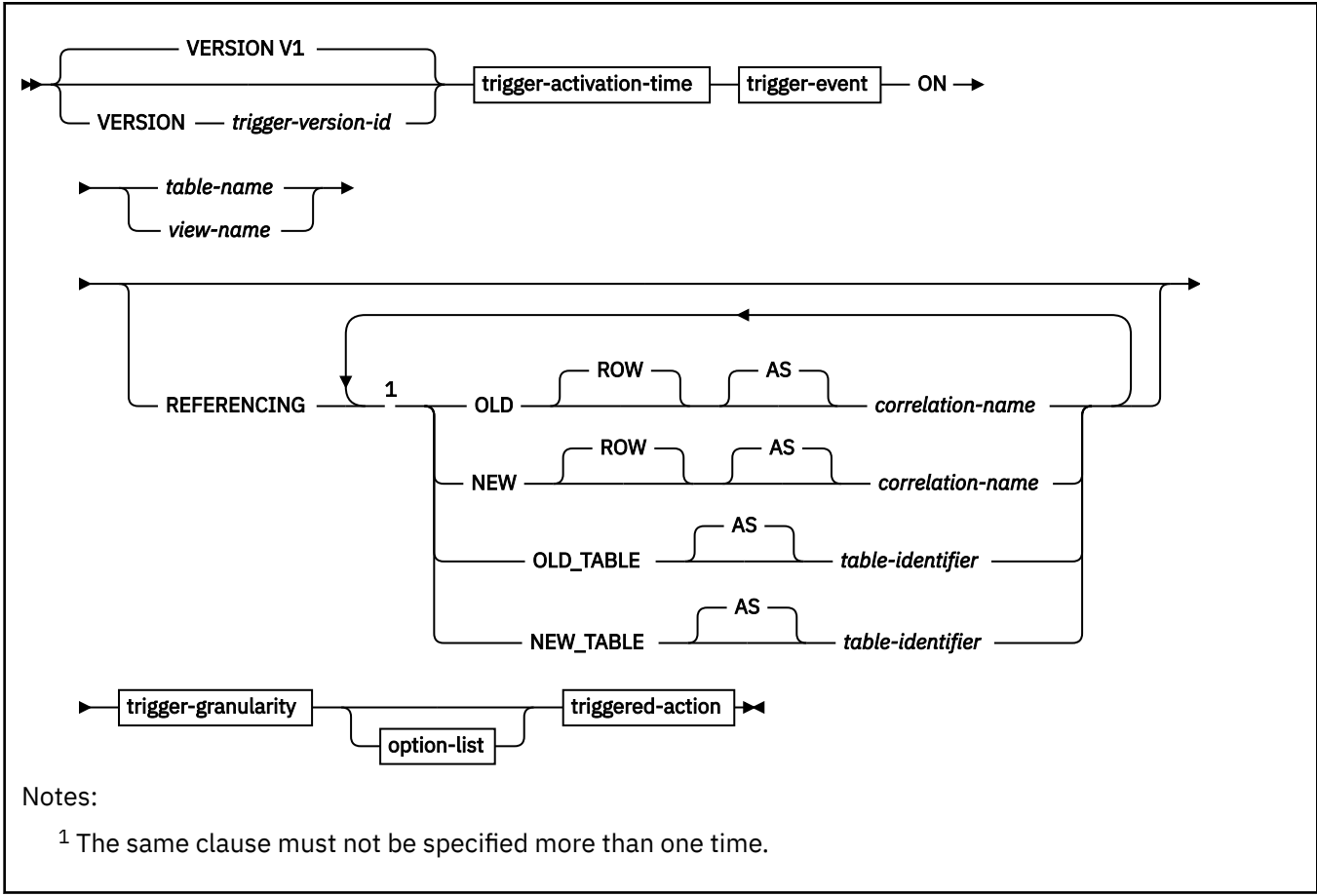

trigger-activation-time



trigger-event

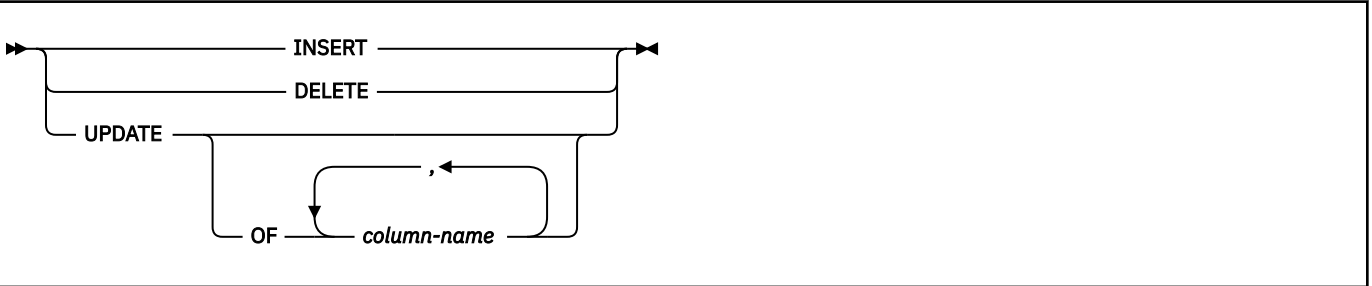

trigger-granularity



triggered-action

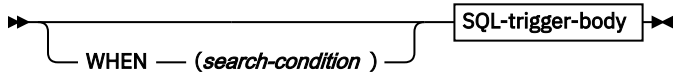

SQL-trigger-body

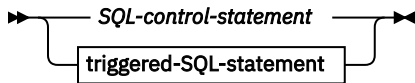

triggered-SQL-statement:

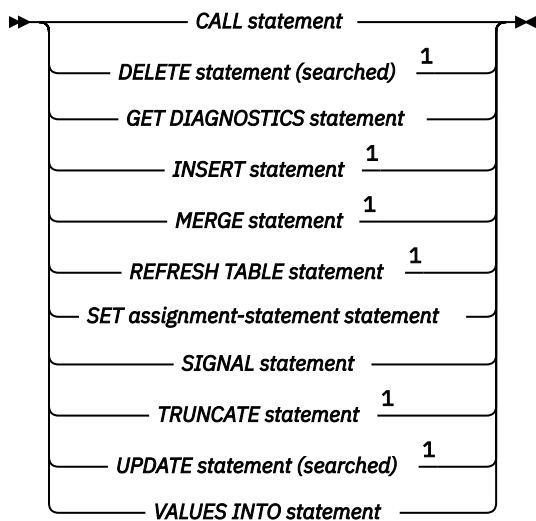

Notes:

¹ The statement is not allowed in an *SQL-trigger-body* for a BEFORE trigger.

option-list: (The options can be specified in any order, but each one can only be specified one time.)

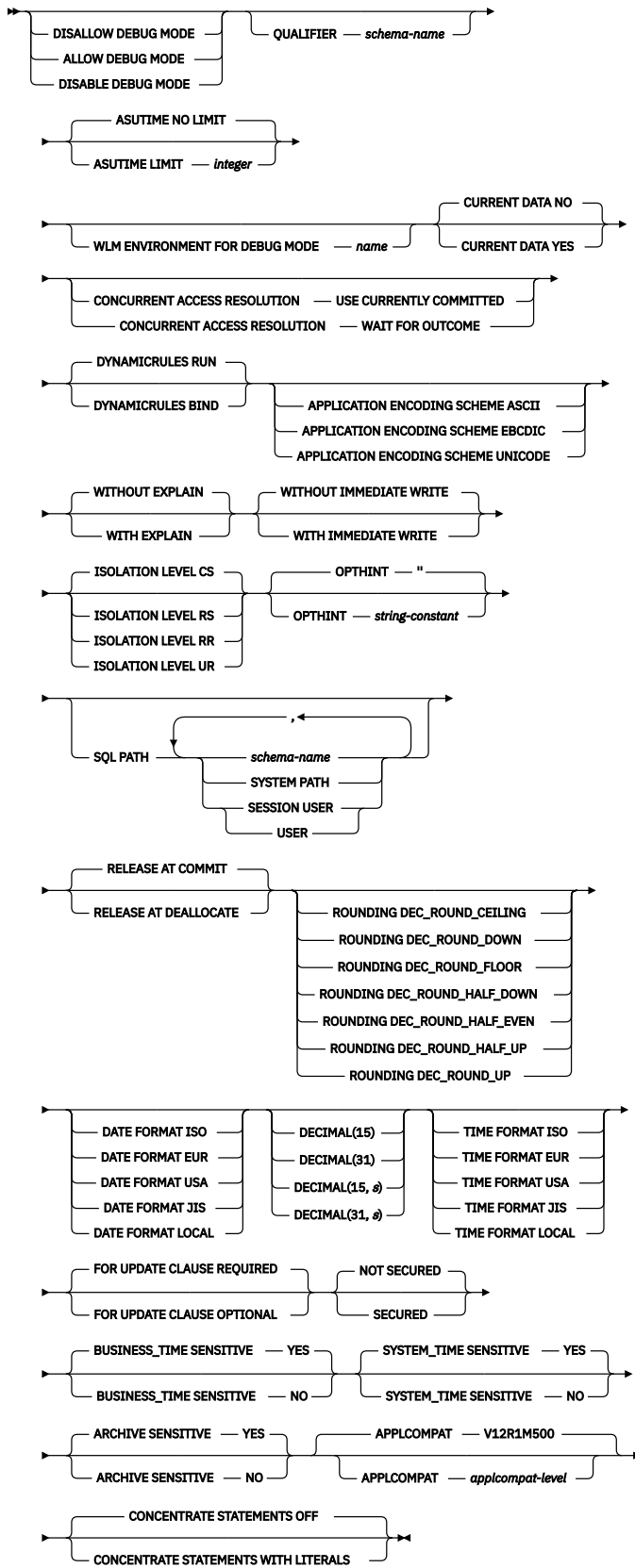

Description for CREATE TRIGGER (advanced)

OR REPLACE

Specifies to replace or change the definition for the trigger, if one exists at the current server. This option is ignored if a definition for the trigger does not exist at the current server.

If the VERSION keyword is not specified, and the trigger does not yet exist, the trigger is created with the initial version of the trigger (V1).

If the VERSION keyword is not specified, and the trigger exists:

- The existing trigger must not be defined with more than a single version or with a single version for which the version id is not V1.
- Otherwise, the only version that currently exists is V1 (or the trigger is a basic trigger), the trigger is recreated as follows:
 - The existing definition is effectively dropped before the definition is replaced in the catalog.
 - Any existing comment is discarded.
 - The definition of the trigger (including the object owner and target table or view name) can change.
 - The timestamp associated with the trigger definition is updated.
 - The create time of the trigger is changed and the activation order of the trigger is not maintained.

If the VERSION keyword is specified and the specified version of the trigger exists, the version is effectively replaced in the catalog as if the ALTER TRIGGER statement had been issued with the REPLACE VERSION clause. *The trigger owner is not changed.* The create time of the trigger is not changed, and the statement does not affect the order of trigger execution.

When you replace a version of a trigger, the following trigger attributes must be the same as the corresponding attributes for the currently active version of the trigger: *trigger-activation-time*, *trigger-event*, table or view name, and *trigger-granularity*. The content of the REFERENCING clause can differ from the other versions of the trigger. For options that are not explicitly specified, the system default values for those options are used, even if those options were explicitly specified for the version of the trigger that is being replaced. This is not the case for versions of the trigger that specified DISABLE DEBUG MODE. If DISABLE DEBUG MODE is specified for a version of a trigger, the option cannot be changed using the REPLACE clause.

If the VERSION keyword is specified and the specified version of the trigger does not exist, the version is defined as if the ALTER TRIGGER statement had been issued with an ADD VERSION clause. *The trigger owner is not changed.* The create time of the trigger is not changed, and the statement does not affect the order of trigger execution.

When you add a new version of a trigger, the following trigger attributes must be the same as the corresponding attributes for the currently active version of the trigger: *trigger-activation-time*, *trigger-event*, table or view name, and *trigger-granularity*. The content of the REFERENCING clause can differ from the other versions of the trigger. For options that are not explicitly specified, the system default values for those options are used.

trigger-name

Names the trigger. The name, including the implicit or explicit schema name, must not identify a trigger that exists at the current server. However, specifying the name of an existing trigger is allowed in the following situations:

- When the OR REPLACE clause is specified to replace an existing trigger
- When the VERSION clause is specified to add or replace a version of an existing trigger

The name is also used to create the trigger package; therefore, if OR REPLACE is not specified, the name must also not identify a package that is already described in the catalog. The schema name becomes the *collection-id* of the trigger package. Although *trigger-name* can be specified as an ordinary or delimited identifier, the name should conform to the rules for an ordinary identifier. Refer to [The implicitly created trigger package](#) for additional information.

The schema name can be 'SYSTOOLS' if the privilege set includes the SYSCTRL privilege. Otherwise, the schema name must not begin with 'SYS' unless the schema name is 'SYSADM', 'SYSIBMADM', or 'SYSPROC'.

VERSION *trigger-version-id*

Specifies the version identifier for the version of the trigger that is to be defined or replaced. See “Naming conventions in SQL” on page 79 for information about specifying *trigger-version-id*. You can use an ALTER TRIGGER statement with the ADD VERSION clause or the CREATE TRIGGER statement with the OR REPLACE clause to create additional versions of the trigger. V1 is the default version identifier. See [Versions of a trigger](#) for more information about the use of versions for triggers.

trigger-activation-time

NO CASCADE

NO CASCADE is allowed for compatibility with prior releases and other products.

BEFORE

Specifies that the trigger is a before trigger. Db2 executes the triggered action before it applies any changes caused by an insert, delete, or update operation on the subject table. It also specifies that the triggered action does not activate other triggers because the triggered action of a before trigger cannot contain any updates, REFRESH TABLE, or TRUNCATE SQL statements.

BEFORE must not be specified when *view-name* is also specified. FOR EACH ROW must be specified for a BEFORE trigger.

AFTER

Specifies that the trigger is an after trigger. Db2 executes the triggered action after it applies any changes caused by an insert, delete, or update operation on the subject table. AFTER must not be specified if *view-name* is also specified.

INSTEAD OF

Specifies that the trigger is an instead of trigger. The associated triggered action replaces the action against the subject view. Only one INSTEAD OF trigger is allowed for each type of operation on a given subject view. Db2 executes the *triggered-action* instead of the insert, update, or delete operation on the subject view.

INSTEAD OF must not be specified when *table-name* is also specified. The WHEN clause can not be specified for an INSTEAD OF trigger. FOR EACH ROW must be specified for an INSTEAD OF trigger.

ON *table-name*

Identifies the subject table of the BEFORE or AFTER trigger definition. The name must identify a base table that exists at the current server. It must not identify a materialized query table, a clone table, a temporary table, an auxiliary table, an alias, a synonym, a real-time statistics table, an accelerator-only table, a catalog table, or a directory table.

ON *view-name*

Identifies the subject view of the INSTEAD OF trigger definition. The name must identify a view that exists at the current server.

view-name must not specify a view where any of the following conditions are true:

- The view is defined with the WITH CASCADED CHECK option (a symmetric view)
- The view on which a symmetric view has been defined
- The view references data that is encoded with different encoding schemes or CCSID values
- The view has a column that is a ROWID column
- The view has a column that is based on an underlying column of any of the following types:
 - A LOB, XML, or ROWID column
 - An identity column
 - A security label column
 - A row change timestamp column

- A row-begin column
- A row-end column
- A transaction start ID column
- The view has columns that have field procedures
- All of the underlying tables of the view are catalog tables
- All of the underlying tables of the view are created global temporary tables
- All of the underlying tables of the view are clone tables
- The view has other views that are dependent on it

REFERENCING

Specifies the correlation names for the transition variables and the table names for the transition tables. For the rows in the subject table that are modified by the triggering SQL operation (insert, delete, or update), a correlation name identifies the columns of a specific row. *table-identifiers* identify the complete set of affected rows. Transition variables with XML types cannot be referenced inside of a trigger. If the column of a transition table is referenced, the data type of the column cannot be XML.

Each row that is affected by the triggering SQL operation is available to the triggered action by qualifying column names with *correlation-names* that are specified as follows:

OLD ROW AS *correlation-name*

Specifies the correlation name that identifies the transition variables containing the values in the row prior to the triggering SQL operation.

NEW ROW AS *correlation-name*

Specifies the correlation name that identifies the transition variables containing the values in the row as modified by the triggering SQL operation and by any assignment statement in a before trigger that has already been executed.

If OLD and NEW are both specified, a reference to a transition variable must be qualified with the associated correlation name.

The complete set of rows that are affected by the triggering operation is available as a transition table to the triggered action. Specify a *table-identifier* to refer to the transition table as follows:

OLD_TABLE AS *table-identifier*

Specifies the name of a temporary table that identifies the values in the complete set of rows that are modified rows by the triggering SQL operation prior to any actual changes.

NEW_TABLE AS *table-identifier*

Specifies the name of a temporary table that identifies the values in the complete set of rows as modified by the triggering SQL operation and by any assignment statement in a before trigger that has already been executed.

Only one OLD and one NEW *correlation-name* can be specified for a trigger. Only one OLD_TABLE and one NEW_TABLE *table-identifier* can be specified for a trigger. All of the *correlation-names* and *table-identifiers* must be unique from one another.

Table 221 on page 1748 summarizes the allowable combinations of transition variables and transition tables that you can specify for the various trigger types. The OLD *correlation-name* and the OLD_TABLE *table-identifier* are valid only if the triggering event is either a delete operation or an update operation. For a delete operation, the OLD *correlation-name* captures the values of the columns in the deleted row, and the OLD_TABLE *table-identifier* captures the values in the set of deleted rows. For an update operation, the OLD *correlation-name* captures the values of the columns of a row before the update operation, and the OLD_TABLE *table-identifier* captures the values in the set of rows before the update operation.

The NEW *correlation-name* and the NEW_TABLE *table-identifier* are valid only if the triggering event is either an insert operation or an update operation. For both operations, the NEW *correlation-name* captures the values of the columns in the inserted or updated row and the NEW_TABLE *table-identifier* captures the values in the set of inserted or updated rows. For BEFORE triggers, the values of the

updated rows include the changes from any assignment statements in the triggered action of BEFORE triggers.

Table 221. Allowable combinations of attributes in a trigger definition

Granularity	Activation time	Triggering SQL operation	Transition variables allowed "1" on page 1748	Transition tables allowed "1" on page 1748
FOR EACH ROW	BEFORE	DELETE	OLD	None
		INSERT	NEW	None
		UPDATE	OLD, NEW	None
	AFTER	DELETE	OLD	OLD_TABLE
		INSERT	NEW	NEW_TABLE
		UPDATE	OLD, NEW	OLD_TABLE, NEW_TABLE
	INSTEAD OF	DELETE	OLD	OLD_TABLE
		INSERT	NEW	NEW_TABLE
		UPDATE	OLD, NEW	OLD_TABLE, NEW_TABLE
FOR EACH STATEMENT	AFTER	DELETE	None	OLD_TABLE
		INSERT	None	NEW_TABLE
		UPDATE	None	OLD_TABLE, NEW_TABLE

Note:

1. If a transition table or variable is referenced where it is not allowed, an error is returned.

A transition variable that has a character data type inherits the subtype and CCSID of the column of the subject table. During the execution of the triggered action, the transition variables are treated like host variables. Therefore, character conversion might occur. However, unlike a host variable, a transition variable can have the bit data attribute, and character conversion never occurs for bit data. A transition variable is considered to be bit data if the column of the table to which it corresponds is bit data.

You cannot modify a transition table; transition tables are read-only. Although a transition table does not inherit any edit or validation procedures from the subject table, it does inherit the encoding scheme and field procedures of the subject table.

The scope of each *correlation-name* and each *table-identifier* is the entire trigger definition.

trigger-granularity

FOR EACH ROW or FOR EACH STATEMENT

Specifies the conditions for which Db2 executes the triggered action.

FOR EACH ROW

Specifies that Db2 executes the triggered action for each row of the subject table that the triggering SQL operation modifies. If the triggering SQL operation does not modify any rows, the triggered action is not executed..

FOR EACH STATEMENT

Specifies that Db2 executes the triggered action only one time for the triggering operation. Even if the triggering operation does not modify or delete any rows, the triggered action is executed one time.

FOR EACH STATEMENT must not be specified for a BEFORE or INSTEAD OF trigger.

FOR EACH ROW or FOR EACH STATEMENT

Specifies the conditions for which Db2 executes the triggered action.

FOR EACH ROW

Specifies that Db2 executes the triggered action for each row of the subject table that the triggering SQL operation modifies. If the triggering SQL operation does not modify any rows, the triggered action is not executed.

FOR EACH STATEMENT

Specifies that Db2 executes the triggered action only one time for the triggering operation. Even if the triggering operation does not modify or delete any rows, the triggered action is executed one time.

FOR EACH STATEMENT must not be specified for a BEFORE or INSTEAD OF trigger.

ALLOW DEBUG MODE, DISALLOW DEBUG MODE, or DISABLE DEBUG MODE

Specifies whether this version of the trigger can be run in debugging mode. The default is determined using the value of the CURRENT DEBUG MODE special register.

ALLOW DEBUG MODE

Specifies that this version of the trigger can be run in debugging mode. When ALLOW DEBUG MODE is in effect, a WLM environment must be available. If you do not specify WLM ENVIRONMENT FOR DEBUG MODE, Db2 uses the default WLM-established stored procedure address space specified at installation time.

DISALLOW DEBUG MODE

Specifies that this version of the trigger cannot be run in debugging mode. You can use an ALTER statement to change this option to ALLOW DEBUG MODE for the initial version of the trigger. When DISALLOW DEBUG MODE is in effect, a WLM environment must be available. If you do not specify WLM ENVIRONMENT FOR DEBUG MODE, Db2 uses the default WLM-established stored procedure address space specified at installation time.

DISABLE DEBUG MODE

Specifies that this version of the trigger can never be run in debugging mode.

This version of the trigger cannot be changed to specify ALLOW DEBUG MODE or DISALLOW DEBUG MODE after this version of the trigger has been created or altered to use DISABLE DEBUG MODE. To change this option, drop the trigger, and create it again using the option that you want. An alternative to dropping and recreating the trigger is to create a version of the trigger that uses the option that you want, and making that version the active version.

When DISABLE DEBUG MODE is in effect, WLM ENVIRONMENT FOR DEBUG MODE is ignored.

QUALIFIER *schema-name*

Specifies the implicit qualifier that is used for unqualified object names that are referenced in the trigger body. For information about how the default for this option is determined, see [“Unqualified alias, index, JAR file, mask, permission, sequence, table, trigger, and view names”](#) on page 86.

ASUTIME

Specifies the total amount of processor time, in CPU service units, that a single invocation of this version of the trigger can run. The value is unrelated to the ASUTIME column of the resource limit specification table.

When you are debugging a trigger, setting a limit can be helpful in case the trigger gets caught in a loop. For information on service units, see [z/OS MVS Initialization and Tuning Guide](#).

NO LIMIT

Specifies that there is no limit on the service units.

NO LIMIT is the default.

LIMIT *integer*

The limit on the number of CPU service units is a positive *integer* in the range 1–2147483647. If the trigger uses more service units than the specified value, Db2 cancels the trigger. The CPU cycles that are consumed by parallel tasks in a trigger do not contribute towards the specified ASUTIME LIMIT.

WLM ENVIRONMENT FOR DEBUG MODE *name*

Specifies the WLM (workload manager) application environment that is used by Db2 when debugging the trigger. The *name* of the WLM environment is an SQL identifier.

If you do not specify WLM ENVIRONMENT FOR DEBUG MODE, Db2 uses the default WLM-established stored procedure address space specified at installation time.

You must have the appropriate authority for the WLM application environment.

The WLM ENVIRONMENT FOR DEBUG MODE value is ignored when DISABLE DEBUG MODE is in effect.

CURRENT DATA YES or CURRENT DATA NO

Specifies whether to require data currency for read-only and ambiguous cursors when the isolation level of cursor stability is in effect. CURRENT DATA also determines whether block fetch can be used for distributed, ambiguous cursors.

CURRENT DATA YES

Specifies that data currency is required for read-only and ambiguous cursors. Db2 acquires page or row locks to ensure data currency. Block fetch is ignored for distributed, ambiguous cursors.

CURRENT DATA NO

Specifies that data currency is not required for read-only and ambiguous cursors. Block fetch is allowed for distributed, ambiguous cursors. Use of CURRENT DATA NO is not recommended if the trigger attempts to dynamically prepare and execute a DELETE WHERE CURRENT OF statement against an ambiguous cursor after that cursor is opened. You receive an error if your trigger attempts to use a DELETE WHERE CURRENT OF statement for any of the following cursors:

- A cursor that is using block fetch
- A cursor that is using query parallelism
- A cursor that is positioned on a row that is modified by this or another application process

CURRENT DATA NO is the default.

CONCURRENT ACCESS RESOLUTION

Specifies the whether processing uses only committed data or whether it will wait for commit or rollback of data that is in the process of being updated.

WAIT FOR OUTCOME

Specifies that processing will wait for the commit or rollback of data that is in the process of being updated.

USE CURRENTLY COMMITTED

Specifies that processing use the currently committed version of the data when data that is in the process of being updated is encountered. USE CURRENTLY COMMITTED is applicable on scans that access tables that are defined in universal table spaces with row or page level lock size.

When there is lock contention between a read transaction and an insert transaction, USE CURRENTLY COMMITTED is applicable to scans with isolation level CS or RS. Applicable scans include intent read scans for read-only and ambiguous queries and for updatable cursors. USE CURRENTLY COMMITTED is also applicable to scans initiated from WHERE predicates of UPDATE or DELETE statements and the subselect of INSERT statements.

When there is lock contention is between a read transaction and a delete transaction, USE CURRENTLY COMMITTED is applicable to scans with isolation level CS and when CURRENT DATA NO is specified.

DYNAMICRULES

Specifies the values that apply, at run time, for the following dynamic SQL attributes:

- The authorization ID that is used to check authorization
- The qualifier that is used for unqualified objects
- The source for application programming options that Db2 uses to parse and semantically verify dynamic SQL statements

In the context of a trigger, DYNAMICRULES also specifies whether dynamic SQL statements can include ALTER, CREATE, and DROP statements.

In addition to the value of the DYNAMICRULES clause, the run time environment of a trigger controls how dynamic SQL statements behave at run time. The combination of the DYNAMICRULES value and the run time environment determines the value for the dynamic SQL attributes. That set of attribute values is called the dynamic SQL statement behavior. The following values can be specified:

RUN

Specifies that dynamic SQL statements are to be processed using run behavior.

RUN is the default.

BIND

Specifies that dynamic SQL statements are to be processed using bind behavior.

See “Authorization IDs and dynamic SQL” on page 94 for information on the effects of these options.

APPLICATION ENCODING SCHEME

Specifies the default encoding scheme for SQL variables in static SQL statements in the trigger body. The value is used for defining an SQL variable in a compound statement if the CCSID clause is not specified as part of the data type.

ASCII

Specifies that the data is encoded using the ASCII CCSIDs of the server.

EBCDIC

Specifies that the data is encoded using the EBCDIC CCSIDs of the server.

UNICODE

Specifies that the data is encoded using the Unicode CCSIDs of the server.

See [ENCODING bind option \(Db2 Commands\)](#) for information about how the default for this option is determined.

WITH EXPLAIN or WITHOUT EXPLAIN

Specifies whether information will be provided about how SQL statements in the trigger will execute.

WITHOUT EXPLAIN

Specifies that information will not be provided about how SQL statements in the trigger will execute.

You can get EXPLAIN output for a statement that is embedded in a trigger that is specified using WITHOUT EXPLAIN by embedding the SQL statement EXPLAIN in the trigger body. Otherwise, the value of the EXPLAIN option applies to all explainable SQL statements in the trigger body, and to the fullselect portion of any DECLARE CURSOR statements.

WITHOUT EXPLAIN is the default.

WITH EXPLAIN

Specifies that information will be provided about how SQL statements in the trigger will execute. Information is inserted into the table *owner*.PLAN_TABLE. *owner* is the authorization ID of the owner of the trigger. Alternatively, the authorization ID of the owner of the trigger can have an alias as *owner*.PLAN_TABLE that points to the base table, PLAN_TABLE. *owner* must also have the appropriate SELECT and INSERT privileges on that table. PLAN_TABLE must have a base table and can have multiple aliases with the same table name, PLAN_TABLE, but have different schema qualifiers. It cannot be a view or a synonym and should exist before the CREATE statement is

processed. In all inserts to *owner*.PLAN_TABLE, the value of QUERYNO is the statement number that is assigned by Db2.

The WITH EXPLAIN option also populates two optional tables, if they exist: DSN_STATEMNT_TABLE and DSN_FUNCTION_TABLE. DSN_STATEMNT_TABLE contains an estimate of the processing cost for an SQL statement. See [Estimating the cost of SQL statements \(Db2 Performance\)](#) for more information. DSN_FUNCTION_TABLE contains information about function resolution. See [Checking how Db2 resolves functions by using DSN_FUNCTION_TABLE \(Db2 Application programming and SQL\)](#) for more information.

For more information about the EXPLAIN statement, including a description of the tables that are populated by the WITH EXPLAIN option, see [“EXPLAIN statement” on page 1917](#).

WITH IMMEDIATE WRITE or WITHOUT IMMEDIATE WRITE

Specifies whether immediate writes are to be done for updates that are made to group buffer pool dependent page sets or partitions. This option is only applicable for data sharing environments. The IMMEDIATEWRITE subsystem parameter has no effect of this option. [IMMEDIATEWRITE bind option \(Db2 Commands\)](#) shows the implied hierarchy of the IMMEDIATEWRITE bind option (which is similar to this trigger option) as it affects run time.

WITHOUT IMMEDIATE WRITE

Specifies that normal write activity is performed. Updated pages that are group buffer pool dependent are written at or before phase one of commit or at the end of abort for transactions that have been rolled back.

WITHOUT IMMEDIATE WRITE is the default.

WITH IMMEDIATE WRITE

Specifies that updated pages that are group buffer pool dependent are immediately written as soon as the buffer update completes. Updated pages are written immediately even if the buffer is updated during forward progress or during the rollback of a transaction. WITH IMMEDIATE WRITE might impact performance.

ISOLATION LEVEL RR, RS, CS, or UR

Specifies how far to isolate the trigger from the effects of other running applications. For information about isolation levels, see [Choosing an ISOLATION option \(Db2 Performance\)](#).

RR

Specifies repeatable read.

RS

Specifies read stability.

CS

Specifies cursor stability. CS is the default.

UR

Specifies uncommitted read.

OPTHINT *string-constant*

Specifies whether query optimization hints are used for static SQL statements that are contained within the body of the trigger.

string-constant is a character string of up to 128 bytes in length, which is used by the Db2 subsystem when searching the PLAN_TABLE for rows to use as input. The default value is an empty string, which indicates that the Db2 subsystem does not use optimization hints for static SQL statements.

Optimization hints are only used if optimization hints are enabled for your system. See [Preparing to influence access paths \(Db2 Performance\)](#) for information about enabling optimization hints.

SQL PATH

Specifies the SQL path that Db2 uses to resolve unqualified user-defined types, functions, and procedure names in the body of the trigger. The default value is "SYSIBM", "SYSFUN", "SYSPROC", "SYSIBMADM", and the value of the QUALIFIER option.

Schemas "SYSIBM", "SYSFUN", "SYSPROC", "SYSIBMADM" do not need to be explicitly specified. If any of these schemas is not explicitly specified, it is implicitly assumed at the beginning the SQL path, in the order listed.

Db2 calculates the length by taking each *schema-name* specified and removing any trailing blanks from it, adding two delimiters around it, and adding one comma after each schema name, except for the last one. The length of the resulting string cannot exceed the length of the CURRENT SCHEMA special register. If you do not specify the "SYSIBM", "SYSFUN", "SYSPROC", "SYSIBMADM", schemas, they are not included in the length of the SQL path. If the total length of the SQL path exceeds the length of the CURRENT PATH special register, Db2 returns an error.

For more information, see:

[“SQL path” on page 85](#)

[“CURRENT SCHEMA special register” on page 206](#)

[“CURRENT PATH special register” on page 200](#)

schema-name

Identifies a schema. Db2 does not verify that the schema exists when the CREATE statement is processed. The same schema name should not appear more than once in the list of schema names.

SYSPUBLIC must not be specified for the SQL path.

SYSTEM PATH

Specifies the schema names "SYSIBM", "SYSFUN", "SYSPROC", "SYSIBMADM".

SESSION_USER or USER

Specifies the value of the SESSION_USER or USER special register, which represents a maximum 8-byte (in EBCDIC) *schema-name*. At the time the CREATE statement is processed, this length is included in the total length of the list of schema names that is specified for the SQL PATH option.

If you specify SESSION_USER (or USER) in a list of schema names, do not use delimiters around the SESSION_USER (or USER) keyword.

RELEASE AT

Specifies when to release resources that the trigger uses: either at each commit point or when the trigger terminates.

COMMIT

Specifies that resources will be released at each commit point.

COMMIT is the default.

DEALLOCATE

Specifies that resources will be released only when the thread terminates. DEALLOCATE has no effect on dynamic SQL statements, which always use RELEASE AT COMMIT, with this exception: When you use the RELEASE AT DEALLOCATE clause and the WITH KEEP DYNAMIC clause, and the subsystem is installed with a value of YES for the field CACHE DYNAMIC SQL on installation panel DSNTIP8, the RELEASE AT DEALLOCATE option is honored for dynamic SELECT and data change statements.

Locks that are acquired for dynamic statements are held until one of the following events occurs:

- The application process ends.
- The application process issues a PREPARE statement with the same statement identifier. (Locks are released at the next commit point).
- The statement is removed from the dynamic statement cache because the statement has not been used. (Locks are released at the next commit point.)
- An object that the statement is dependent on is dropped or altered, or a privilege that the statement needs is revoked. (Locks are released at the next commit point.)

RELEASE AT DEALLOCATE can increase the package or plan size because additional items become resident in the package or plan.

For more information, see [Choosing a RELEASE option \(Db2 Performance\)](#).

ROUNDING

Specifies the rounding mode for manipulation of DECFLOAT data. The default value is taken from the DEFAULT DECIMAL FLOATING POINT ROUNDING MODE in the application programming defaults module.

DEC_ROUND_CEILING

Specifies numbers are rounded towards positive infinity.

DEC_ROUND_DOWN

Specifies numbers are rounded towards 0 (truncation).

DEC_ROUND_FLOOR

Specifies numbers are rounded towards negative infinity.

DEC_ROUND_HALF_DOWN

Specifies numbers are rounded to nearest; if equidistant, round down.

DEC_ROUND_HALF_EVEN

Specifies numbers are rounded to nearest; if equidistant, round so that the final digit is even.

DEC_ROUND_HALF_UP

Specifies numbers are rounded to nearest; if equidistant, round up.

DEC_ROUND_UP

Specifies numbers are rounded away from 0.

DATE FORMAT ISO, EUR, USA, JIS, or LOCAL

Specifies the date format for result values that are string representations of date or time values. See [“String representations of datetime values” on page 120](#) for more information.

The default format is specified in the DATE FORMAT field of installation panel DSNTIP4 of the system where the routine is defined. You cannot use the LOCAL option unless you have a date exit routine.

DECIMAL(15), DECIMAL(31), DECIMAL(15,s), or DECIMAL(31,s)

Specifies the maximum precision that is to be used for decimal arithmetic operations. See [“Arithmetic with two decimal operands” on page 251](#) for more information. The default format is specified in the DECIMAL ARITHMETIC field of installation panel DSNTIPF of the system where the routine is defined. If the form *pp.s* is specified, *s* must be a number in the range 1–9. *s* represents the minimum scale that is to be used for division.

TIME FORMAT ISO, EUR, USA, JIS, or LOCAL

Specifies the time format for result values that are string representations of date or time values. See [“String representations of datetime values” on page 120](#) for more information.

The default format is specified in the TIME FORMAT field of installation panel DSNTIP4 of the system where the routine is defined. You cannot use the LOCAL option unless you have a date exit routine.

FOR UPDATE CLAUSE OPTIONAL or FOR UPDATE CLAUSE REQUIRED

Specifies whether the FOR UPDATE clause is required for a DECLARE CURSOR statement if the cursor is to be used to perform positioned updates.

FOR UPDATE CLAUSE REQUIRED

Specifies that a FOR UPDATE clause must be specified as part of the cursor definition if the cursor will be used to make positioned updates.

FOR UPDATE CLAUSE REQUIRED is the default.

FOR UPDATE CLAUSE OPTIONAL

Specifies that the FOR UPDATE clause does not need to be specified in order for a cursor to be used for positioned updates. The trigger body can include positioned UPDATE statements that update columns that the user is authorized to update.

The FOR UPDATE clause with no column list applies to static or dynamic SQL statements. Even if you do not use this clause, you can specify FOR UPDATE OF with a column list to restrict updates to only the columns that are identified in the FOR UPDATE clause and to specify the acquisition of update locks.

NOT SECURED or SECURED

Specifies whether the trigger is considered secure. NOT SECURED is the default.

SECURED

Specifies the trigger is considered secure.

SECURED must be specified for a trigger if its subject table is using row access control or column access control. SECURED must also be specified for a trigger that is created for a view and one or more of the underlying tables in the view definition is using row access control or column access control.

NOT SECURED

Specifies the trigger is considered not secure.

NOT SECURED must not be specified for a trigger whose subject table is using row access control or column access control. NOT SECURED must also not be specified for a trigger that is created for a view and one or more of the underlying tables in the view definition is using row access control or column access control.

BUSINESS_TIME SENSITIVE

Determines whether references to application-period temporal tables in both static and dynamic SQL statements are affected by the value of the CURRENT TEMPORAL BUSINESS_TIME special register.

YES

References to application-period temporal tables are affected by the value of the CURRENT TEMPORAL BUSINESS_TIME special register. YES is the default value.

NO

References to application-period temporal tables are not affected by the value of the CURRENT TEMPORAL BUSINESS_TIME special register.

For more information, see [“CURRENT TEMPORAL BUSINESS_TIME special register”](#) on page 208.

SYSTEM_TIME SENSITIVE

Determines whether references to system-period temporal tables in both static and dynamic SQL statements are affected by the value of the CURRENT TEMPORAL SYSTEM_TIME special register.

YES

References to system-period temporal tables are affected by the value of the CURRENT TEMPORAL SYSTEM_TIME special register. YES is the default value.

NO

References to system-period temporal tables are not affected by the value of the CURRENT TEMPORAL SYSTEM_TIME special register.

For more information, see [“CURRENT TEMPORAL SYSTEM_TIME special register”](#) on page 210.

ARCHIVE SENSITIVE

Determines whether references to archive-enabled tables in SQL statements are affected by the value of the SYSIBMADM.GET_ARCHIVE built-in global variable.

YES

References to archive-enabled tables are affected by the value of the SYSIBMADM.GET_ARCHIVE built-in global variable. YES is the default value.

NO

References to archive-enabled tables are not affected by the value of the SYSIBMADM.GET_ARCHIVE built-in global variable.

For related information, see [“GET_ARCHIVE”](#) on page 330.

APPLCOMPAT *applcompat-level*

Specifies the application compatibility level behavior for static SQL statements in the trigger body. The default value is V12R1M500. The following *applcompat-level* values can be specified:

VuuRrMmm

Compatibility with the behavior of the identified Db2 function level. For example, V12R1M510 specifies compatibility with the highest available Db2 12 function level. The equivalent function level or higher must be activated.

For the new capabilities that become available in each application compatibility level, see:

- [SQL changes in Db2 13 application compatibility levels](#)
- [SQL changes in Db2 12 application compatibility levels](#)

Tip: Extra program preparation steps might be required to increase the application compatibility level for applications that use data server clients or drivers to access Db2 for z/OS. For more information, see [Setting application compatibility levels for data server clients and drivers \(Db2 Application programming and SQL\)](#).

V12R1

Compatibility with the behavior of Db2 12 function level 500. This value has the same result as specifying V12R1M500.

Values such as V11R1 and V10R1 for compatibility with previous Db2 releases are not supported for triggers.

For more information, see [APPLCOMPAT bind option \(Db2 Commands\)](#) and [APPL COMPAT LEVEL field \(APPLCOMPAT subsystem parameter\) \(Db2 Installation and Migration\)](#)

CONCENTRATE STATEMENTS OFF or CONCENTRATE STATEMENTS WITH LITERALS

Specifies whether a dynamic SQL statement that specifies literal constants will be cached as a separate unique statement entry in the dynamic statement cache instead of sharing an existing statement in the cache. Dynamic SQL statements are eligible to share an existing statement in the cache if the new statement meets all of the conditions for sharing a cached version of the same dynamic statement except that the new statement specifies one or more literal constants that are different than the cached statement.

CONCENTRATE STATEMENTS OFF

Specifies that the dynamic SQL statement that specifies literal constants will be cached as a unique statement entry if it specifies one or more constants that are different than the cached version of the same dynamic statement. CONCENTRATE STATEMENTS OFF is the default dynamic statement caching behavior.

CONCENTRATE STATEMENTS WITH LITERALS

Specifies that the dynamic SQL statement that specifies literal constants will share a cached version of the same dynamic statement that is also prepared using the CONCENTRATE STATEMENTS WITH LITERALS option if the new dynamic statement meets all of the conditions for sharing the cached statement and the constants that are specified can be reused in place of the constants in the cached statement.

trigger-event

Specifies that the triggered action that is associated with the trigger is to be executed when the trigger event is applied to the subject table or view.

INSERT

Specifies that the trigger is an insert trigger. Db2 executes the triggered action whenever there is an insert operation on the subject table. However, if the insert trigger is defined on any explain table, and the insert operation was caused by Db2 adding a row to the table, the triggered action is not executed.

DELETE

Specifies that the trigger is a delete trigger. Db2 executes the triggered action whenever there is a delete operation on the subject table.

UPDATE

Specifies that the trigger is an update trigger. Db2 executes the triggered action whenever there is an update operation on the subject table.

If you do not specify a list of column names, an update operation on any column of the subject table, including columns that are subsequently added with the ALTER TABLE statement, activates the triggered action.

OF *column-name*,...

Each *column-name* that you specify must be a column of the subject table and must appear in the list only once. An update operation on any of the listed columns activates the triggered action.

UPDATE OF *column-name* cannot be specified for an INSTEAD OF trigger.

triggered-action

Specifies the action to be performed when the trigger is activated. The *triggered-action* is composed of one or more SQL statements and an optional condition that controls whether the statements are executed.

WHEN (*search-condition*)

Specifies a condition that evaluates to true, false, or unknown. The triggered SQL statements are executed only if the *search-condition* evaluates to true. If the WHEN clause is omitted, the associated SQL statements are always executed.

The WHEN clause must not be specified for an INSTEAD OF trigger.

SQL-trigger-body

Specifies a single *SQL-control-statement*, including a compound statement, or *triggered-SQL-statement* that is to be executed for the *triggered-action*. See [Chapter 8, “SQL procedural language \(SQL PL\),” on page 2207](#) for more information about defining SQL triggers.

SQL-control-statement

Specifies an SQL control statement, which can include nested control statements and other SQL statements specified in the syntax diagram for “[SQL-procedure-statement \(SQL PL\)](#)” on [page 2212](#). The statements that can be specified for *SQL-procedure-statement* are subject to the syntax notes relating to triggers.

triggered-SQL-statement

Specifies an SQL statement that is the only statement in a trigger body.

Only certain SQL statements can be specified in the *SQL-trigger-body*.

The trigger body must not contain a statement that is not supported.

- A statement in the trigger body must not refer to host variables, undefined transition variables, or declared temporary tables.
- A statement in the trigger body must only refer to a table or view that is at the current server.
- A statement in the trigger body must only invoke a stored procedure or user-defined function that is at the current server. An invoked routine can, however, access a server other than the current server.
- A statement in the trigger body must not modify a column that is part of a BUSINESS_TIME period.
- The trigger body must not, directly or indirectly, issue a CALL statement for a procedure that contains one of the following statements:
 - COMMIT
 - CONNECT
 - RELEASE *connection*

- RELEASE SAVEPOINT
- ROLLBACK (without TO SAVEPOINT)
- SAVEPOINT
- SET CONNECTION
- The trigger body must not, directly or indirectly, issue a CALL statement for a procedure that is defined with the COMMIT ON RETURN option.
- If the trigger is a before trigger:
 - The trigger body must not contain a DELETE, INSERT, MERGE, REFRESH TABLE, TRUNCATE, UPDATE statement, or SELECT FROM *data-change-statement*.
 - The trigger body must not, directly or indirectly, invoke a routine containing one of the following statements:
 - ALTER
 - COMMENT
 - CREATE
 - DECLARE GLOBAL TEMPORARY TABLE
 - DELETE
 - DROP
 - EXCHANGE
 - GRANT
 - INSERT
 - LABEL
 - LOCK TABLE
 - MERGE
 - REFRESH TABLE
 - RENAME
 - REVOKE
 - TRUNCATE
 - UPDATE

A CREATE TRIGGER statement (or ALTER TRIGGER statement) cannot contain a hexadecimal graphic string (GX) constant.

The triggered action can refer to the values in the set of affected rows. This action is supported through the use of transition variables and transition tables.

All tables, views, aliases, sequences, roles, user-defined data types, user-defined functions, and procedures referenced in the *triggered-action* must exist at the current server when the trigger is created, or the version of the trigger is defined. The table or view that an alias refers to must also exist when the trigger is created, or the version of the trigger is defined.

WRAPPED *obfuscated-statement-text*

Specifies the encoded definition of the trigger. A CREATE TRIGGER statement can be encoded using the WRAP scalar function.

WRAPPED must not be specified on a static CREATE statement.

Notes for CREATE TRIGGER (advanced)

Owner privileges:

When an INSTEAD OF trigger is defined, the associated privilege (INSERT, UPDATE, or DELETE on the view) is given to the owner of the view. The owner is granted the privilege with the ability to grant that

privilege to others. For more information about ownership of an object, see [“Authorization, privileges, permissions, masks, and object ownership”](#) on page 90.

Execution authorization:

The user executing the triggering SQL operation does not need authority to execute a *SQL-trigger-body*. An *SQL-trigger-body* executes using the authority of the owner of the trigger.

Activating a trigger:

Only insert, delete, or update operations can activate a trigger. The activation of a trigger might cause trigger cascading. *Trigger cascading* is the result of the activation of one trigger that executes SQL statements that cause the activation of other triggers or even the same trigger again. The triggered actions might also cause updates as a result of the original modification, which can result in the activation of additional triggers. With trigger cascading, a significant chain of triggers might be activated, causing a significant change to the database as a result of a single insert, delete, or update operation. The number of levels of nested trigger cascading is limited to 16.

Loading a table with the LOAD utility does not activate any triggers that are defined for the table if the SHRLEVEL NONE option is specified or accepted as the default. If the LOAD statement includes the SHRLEVEL CHANGE option, triggers are activated when loading a table with the LOAD utility.

Adding triggers to enforce constraints:

Adding a trigger on a table that already has rows in it will not cause the *triggered-action* to be executed. Thus, if the trigger is designed to enforce constraints on the data in the table, the data in the existing rows might not satisfy those constraints.

Multiple triggers:

Multiple triggers that have the same activation time and triggering event can be defined on a table. The triggers are activated in the order in which they were created. For example, the trigger that was created first is executed first; the trigger that was created second is executed second. If the OR REPLACE option is used to replace an existing trigger, the create time is changed and therefore might affect the order of trigger execution.

Transition variables and transition tables:

The *triggered-action* can refer to the values in the set of affected rows. This action is supported through the use of transition variables and transition tables.

A transition variable has the same name and data type as the corresponding column of the table that the trigger is defined on, and is nullable. A transition variable contains the value of a column in an affected row. A transition variable is qualified by a correlation name that identifies whether the reference is to the old value (before the update) or the new value (after the update). A transition variable can be referenced in the search condition, or in an SQL statement in the trigger body, wherever a variable would be allowed if the reference was made outside the body of a trigger. A new transition variable can be assigned a value in a before update or insert trigger. The values of the updated rows include the changes from any assignments to transition variables in the *triggered-action* of a before trigger.

A transition table contains the complete set of affected rows: either the old values (before the update) or the new values (after the update). A transition table is read-only, and can be referenced in the *triggered-action* of an after or instead of trigger. A column of a transition table has the same name, data type, and null attribute as the corresponding column of the table that the trigger is defined on. A transition table is referenced using an associated table identifier that allows the complete set of affected rows to be treated as a table. A transition table can be referenced in a search condition, or in an SQL statement in the trigger body, wherever a table would be allowed if the reference was made outside the body of a trigger. In addition, a transition table can be passed as an argument to a user-defined function or procedure, specifying the TABLE keyword before the table identifier for the transition table. When the function or procedure is invoked, a table locator is passed for the transition table.

Considerations for table-locator-reference elements:

table-locator-reference must not be specified in the body of a trigger.

Considerations for implicitly hidden columns:

In the body of a trigger, a transition variable that corresponds to an implicitly hidden column can be referenced. A transition table, that corresponds to a table with an implicitly hidden column, includes that column as part of the transition table. Likewise, a transition variable will exist for the column that is defined as implicitly hidden. A transition variable that corresponds to an implicitly hidden column can be referenced in the body of a trigger.

Lines within the advanced trigger definition:

When an advanced trigger is created, information is retained on lines in the CREATE statement. Lines are determined by the presence of the new line control character.

In an advanced trigger, a *new line control character* is a special character that is used for a new line. The new line control characters for an advanced trigger include:

- Line feed
- New line
- Carriage return
- Carriage return, followed by a line feed
- Carriage return, followed by a new line

For more information about control characters, see [“Control characters” on page 76](#).

Identifier resolution:

See [SQL control statements for SQL routines](#) for information on how names are resolved to columns, SQL variables, transition variables, or global variables in the trigger body.

If non-unique names are used for columns, SQL variables, transition variables, or global variables, qualify the non-unique names by using the table designator for columns, the label name for SQL variables, correlation name for transition variables, and schema for global variables.

Considerations for transition variables in AFTER and INSTEAD OF triggers:

Transition variables cannot be modified in an AFTER or INSTEAD OF trigger.

Considerations for INSTEAD OF triggers:

The addition of an INSTEAD OF trigger for a view affects the read-only characteristic of the view. If a read-only view has a dependency relationship with an INSTEAD OF trigger, the type of operation that is defined for the INSTEAD OF trigger defines whether the view is deletable, insertable, or updatable.

The creation of an INSTEAD OF trigger causes dependent packages, plans, and statements in the dynamic statement cache to be marked invalid if the view definition is not read-only.

The initial values for new transition variables or new transition table columns that are visible in an INSTEAD OF INSERT trigger are set as follows:

- If a value is explicitly specified for a column in the insert operation, the corresponding new transition variable is that explicitly specified value.
- If a value is not explicitly specified for a column in the insert operation or the DEFAULT clause is specified, the corresponding new transition variable is:
 - the default value of the underlying table column if the view column is updatable (without the INSTEAD OF trigger)
 - otherwise, the null value

If a view column is not nullable and does not have a default, the value must be explicitly specified in the insert operation.

The initial values for new transition variables that are visible in an INSTEAD OF UPDATE trigger are set as follows:

- If a value is explicitly specified for a column in the update operation, the corresponding new transition variable is that explicitly specified value
- If the DEFAULT clause is explicitly specified for a column in the update operation, the corresponding new transition variable is:

- the default value of the underlying table column if the view column is updatable (without the `INSTEAD OF` trigger)
- otherwise, the null value

If a view column is not nullable and does not have a default, the value must be explicitly specified in the update operation.

- Otherwise, the corresponding new transition variable is the existing value of the column in the row.

Considerations for a MERGE statement:

The MERGE statement can execute insert, delete, and update operations. The applicable triggers are activated for the MERGE statement for the data change operations that are executed.

Considerations for triggers that are defined on tables that contain XML columns:

Although a trigger can be defined on a table that contains an XML column:

- An XML column cannot be referenced with a transition variable in the trigger body. An *SQL-procedure-statement* cannot reference a transition variable that is an XML data type.
- An XML column of a transition table cannot be referenced in the trigger body. An *SQL-procedure-statement* cannot reference a column in a transition table that is an XML data type.

Creating a trigger with the SECURED option:

Typically, the security administrator will examine the data that is accessed by a trigger, ensure that it is secure, and grant the `CREATE_SECURE_OBJECT` privilege to someone who requires the privileges to create a secured trigger. After the trigger is created, the security administrator will revoke the `CREATE_SECURE_OBJECT` privilege from the owner of the trigger.

The trigger is considered secure after the `CREATE TRIGGER` statement is executed. Db2 treats the `SECURED` attribute as an assertion that declares that the user has established an audit procedure for all activities in the trigger body. If a secure trigger references user-defined functions, Db2 assumes those functions are secure without validation. If those functions can access sensitive data, the user with `SECADM` authority needs to ensure that those functions are allowed to access that data and that an audit procedure is in place for all versions of those functions, and that all subsequent `ALTER FUNCTION` statements or changes to external packages are being reviewed by this audit process.

A trigger must be secure if its subject table is using row access control or column access control. `SECURED` must also be specified for a trigger that is created for a view and one or more of the underlying tables in the view definition is using row access control or column access control.

Creating a trigger with the NOT SECURED option:

The `CREATE TRIGGER` statement returns an error if the subject table of the trigger is using row access control or column access control, or if the trigger is for a view and one or more of the underlying tables in the view definition is using row access control or column access control.

Row and column access control that is not enforced for transition variables and transition tables:

If row access control or column access control is enforced for the subject table of the trigger, row permissions and column masks are not applied to the initial values of transition variables and transition tables. Row access control and column access control is enforced for the triggering table, but is ignored for transition variables and transition tables that are referenced in the body of the trigger body or are passed as arguments to user-defined functions that are invoked in the body of the trigger. To ensure that there are no security concerns for SQL statements accessing sensitive data in transition variables and transition tables in the trigger action, the trigger must be created with the `SECURED` option. If a trigger is not secure, the `CREATE TRIGGER` statement returns an error.

Versions of a trigger:

The `CREATE TRIGGER` statement defines the initial version of the trigger. Only one version of the trigger is considered to be the active version of the trigger. You can define additional versions using the `ADD VERSION` clause of the `ALTER TRIGGER` statement, or the `CREATE TRIGGER` statement with the `OR REPLACE` clause and the `VERSION` clause where the trigger already exists. You can replace a version using the `REPLACE VERSION` clause of the `ALTER PROCEDURE` statement, or the `CREATE PROCEDURE` statement with the `OR REPLACE` clause and the `VERSION` clause, when the procedure version already exists. For all versions of a trigger, the following trigger attributes must be the same:

trigger-activation-time, *trigger-event*, table or view name, and *trigger-granularity*. The content of the REFERENCING clause can differ for each version of the trigger.

Restrictions involving pending definition changes:

CREATE TRIGGER is not allowed if the trigger is defined on a table for which there are pending definition changes.

Considerations for the special plan, statement, and function tables for EXPLAIN:

You can create a trigger on PLAN_TABLE, DSN_STATEMNT_TABLE, or DSN_FUNCTION_TABLE. However, insert triggers that are defined on these tables are not activated when Db2 adds rows to the tables.

Dependent objects:

A trigger is dependent on the triggering table or view and objects that are referenced in the trigger body.

Adding a column to a subject table or a table referenced in the *triggered-action*:

If a column is added to the subject table after triggers have been defined, the following rules apply:

- If the trigger is an update trigger that was defined without an explicit list of column names, an update to the new column activates the trigger.
- If the subject table is referenced in the *triggered-action*, the new column is not accessible to the SQL statements until the trigger package is rebound.
- The OLD_TABLE and the NEW_TABLE transition tables contain the new column, but the column cannot be referenced unless the trigger is re-created. If the transition tables are passed to a user-defined function or a stored procedure, the user-defined function or stored procedure must be re-created with the new definition of the table (that is, the function or procedure must be dropped and re-created), and the package for the user-defined function or stored procedure must be rebound.

If a column is added to any table that is referenced in the *triggered-action*, the new column is not accessible to the SQL statements until the trigger package is rebound.

Altering the attributes of a column that the triggered action references:

If a column is altered in the table on which the trigger is defined (the subject table), the alter is processed, and the dependent trigger packages are invalidated.

Renaming the table for which the trigger is defined, or tables referenced in the *triggered-action*:

You cannot rename a table for which a trigger is defined (the subject table). Except for the subject table, you can rename any table to which the SQL statements in the triggered action refer. After renaming such a table, drop the trigger and then re-create the trigger so that it refers to the renamed table.

Dropping the table or view for which a trigger is defined:

If the table or view that a trigger is defined on is dropped, the trigger is also dropped.

Effects of dropping or revoking privileges on an object referenced in the *triggered-action*:

Dropping an object that is referenced in the body of a trigger, or revoking a privilege to an object referenced in the body of a trigger, may result in the following:

- Dropping any table, view, alias, or index that is referenced or used within the SQL statements in the triggered action causes the trigger and its package to be invalidated.
- Dropping a synonym that is referenced does not have any effect on the trigger or its package.
- Dropping a user-defined function that is referenced by the SQL statements in the triggered action is not allowed. An error occurs.
- Dropping a sequence that is referenced by the SQL statements in the triggered action is not allowed. An error occurs.
- Revoking a privilege on which the trigger depends causes the trigger and its package to be invalidated. If the appropriate privilege does not exist when the trigger package is rebound, the SQL statement that references the object fails.

Error handling in triggers:

A trigger can return errors, like other SQL statements. Applications need to account for the possible errors that can be expected when a trigger is invoked. Any exception SQLSTATE that is not handled within the trigger body (using a handler) results in the return of the exception SQLSTATE to the statement that caused the trigger to be activated. For example, if a SIGNAL statement (RESIGNAL statement or RAISE_ERROR function) raises a non-severe error in the *SQL-trigger-body*, and the condition is not handled within the trigger body, SQLCODE -438 and the corresponding SQLSTATE are returned. Other non-severe errors are returned with SQLCODE -723 and SQLSTATE 09000. Severe errors that occur during the execution of triggered SQL statements are returned with SQLCODE -901, -906, -911, or -913, and the corresponding SQLSTATE. Warnings are not returned.

Triggers and global variables:

The content of a global variable that is referenced by a trigger is inherited from the triggering SQL operation (delete, insert, or update).

Special registers:

The values of the special registers that are used in the trigger body are determined when the trigger is activated. The value of the CURRENT PACKAGESET special register is set to the schema name of the trigger, and the values of the other special registers are inherited from the triggering SQL operation (insert, update, or delete). Special register values are saved when a trigger is activated and are restored on return from the trigger. The CURRENT DATE, CURRENT TIME, and CURRENT TIMESTAMP special registers are not restored on return from the trigger.

Result sets for stored procedures:

If a trigger invokes a stored procedure that returns result sets, the application that activated the trigger cannot access those result sets.

Transaction isolation:

All of the statements in the *SQL-trigger-body* run under the isolation level that is in effect for the trigger.

Limiting processor time:

The Db2 resource limit facility allows you to specify the maximum amount of processor time for a dynamic, manipulative SQL statement such as SELECT or SQL data change statements. The execution of a trigger is counted as part of the triggering SQL statement. The ASUTIME trigger option can be used to specify such a limit.

Errors binding triggers:

When a CREATE TRIGGER statement is bound, the SQL statements within the triggered action might not be fully parsed. Syntax errors in those statements might not be caught until the CREATE TRIGGER statement is executed.

Characteristics of the package that is generated for a trigger:

The package that is associated with the trigger is named as follows:

- *location* is set to the value of the CURRENT SERVER special register.
- *collection-id* (schema) for the package is the same as the schema qualifier of the trigger.
- *package-id* is the same as the name of the trigger.

The package is generated using the bind options that correspond to the implicitly or explicitly specified trigger options. See [Table 191 on page 1361](#) for more information. In addition to the corresponding bind options, the package is generated using the following bind options:

- FLAG(I)
- SQLERROR(NOPACKAGE)
- ENABLE(*)
- VALIDATE(BIND)

A trigger package becomes invalid if an object or privilege on which it depends is dropped or revoked. The next time that the trigger is activated, Db2 attempts to rebind the invalid trigger package. If the automatic rebind is unsuccessful, the trigger package remains invalid.

You cannot create another package from the trigger package, such as with the BIND COPY command. The only way to drop a trigger package is to drop the trigger or the subject table or view. Dropping the trigger drops the trigger package; dropping the subject table or view drops the trigger and the trigger package.

Each time that the trigger activates, the trigger package executes one or more times.

Considerations for SQL processor programs:

SQL processor programs, such as SPUFI, the command line processor, and DSNTEP2, might not correctly parse SQL statements in the triggered action that are ended with semicolons. These processor programs accept multiple SQL statements, each separated with a terminator character, as input. Processor programs that use a semicolon as the SQL statement terminator can truncate a CREATE TRIGGER statement with embedded semicolons and pass only a portion of it to Db2. Therefore, you might need to change the SQL terminator character for these processor programs. For information on changing the terminator character for SPUFI and DSNTEP2, see [Setting the SQL terminator character in a SPUFI input data set \(Db2 Application programming and SQL\)](#) and [DSNTEP2 and DSNTEP4 sample programs \(Db2 Application programming and SQL\)](#).

Application compatibility level considerations for trigger objects

The application compatibility level controls the adoption and use of new capabilities and enhancements. When an object is created or altered, two separate application compatibility levels are used: one to process the definition of the object, and the other for processing the SQL statements in the object body:

Object definition	<p>The CURRENT APPLICATION COMPATIBILITY special register value is used to process the object definition, except for statements in the object body</p> <p>This application compatibility level is stored in the SYSENVIRONMENT.APPLCOMPAT column. You can use the environment ID value in the catalog definition of the object to locate the SYSENVIRONMENT row with the matching ENVID value.</p> <p>This application compatibility level can be changed when the object is regenerated.</p>
Statements in the object body	<p>The application compatibility level that is implicitly or explicitly specified with the APPLCOMPAT option of the CREATE or ALTER statement is used to process statements in the object body.</p> <p>This application compatibility level is stored in the SYSPACKAGE.APPLCOMPAT column for the package associated with the object definition.</p>

Alternative syntax and synonyms:

To provide compatibility with previous releases of Db2 or other products in the Db2 family, Db2 supports the following keywords:

- OLD TABLE as a synonym for OLD_TABLE
- NEW TABLE as a synonym for NEW_TABLE

Obfuscated statements:

A CREATE TRIGGER statement can be executed in obfuscated form. In an obfuscated statement, only the trigger name and the WRAPPED keyword are readable. The rest of the statement is encoded in such a way that it is not readable but can be decoded by a database server that supports obfuscated statements. The WRAP scalar function produces obfuscated statements. Any debug options that are specified when the trigger is created from an obfuscated statement are ignored.

Examples for CREATE TRIGGER (advanced)

Example 1

Create two triggers that track the number of employees that a company manages. The subject table is the EMPLOYEE table, and the triggers increment and decrement a column with the total number of employees in the COMPANY_STATS table. The tables have these columns:

EMPLOYEE table: ID, NAME, ADDRESS, and POSITION

COMPANY_STATS table: NBEMP, NBPRODUCT, and REVENUE

This example shows the use of transition variables in a row trigger to maintain summary data in another table.

Create the first trigger, NEW_HIRE, so that it increments the number of employees each time a new person is hired; that is, each time a new row is inserted into the EMPLOYEE table, increase the value of column NBEMP in table COMPANY_STATS by 1.

```
CREATE TRIGGER NEW_HIRE
  AFTER INSERT ON EMPLOYEE
  FOR EACH ROW
  BEGIN ATOMIC
    UPDATE COMPANY_STATS SET NBEMP = NBEMP + 1;
  END
```

Create the second trigger, FORM_EMP, so that it decrements the number of employees each time an employee leaves the company; that is, each time a row is deleted from the table EMPLOYEE, decrease the value of column NBEMP in table COMPANY_STATS by 1.

```
CREATE TRIGGER FORM_EMP
  AFTER DELETE ON EMPLOYEE
  FOR EACH ROW
  BEGIN ATOMIC
    UPDATE COMPANY_STATS SET NBEMP = NBEMP - 1;
  END
```

Example 2

Create a trigger, REORDER, that invokes user-defined function ISSUE_SHIP_REQUEST to issue a shipping request whenever a parts record is updated and the on-hand quantity for the affected part is less than 10% of its maximum stocked quantity. User-defined function ISSUE_SHIP_REQUEST orders a quantity of the part that is equal to the part's maximum stocked quantity minus its on-hand quantity; ensures that the request is sent to the appropriate supplier, and returns the quantity ordered.

The parts records are in the PARTS table. Although the table has more columns, the trigger is activated only when columns ON_HAND and MAX_STOCKED are updated.

```
CREATE TRIGGER REORDER
  AFTER UPDATE OF ON_HAND, MAX_STOCKED ON PARTS
  REFERENCING NEW AS NROW
  FOR EACH ROW
  WHEN (NROW.ON_HAND < 0.10 * NROW.MAX_STOCKED)
  BEGIN ATOMIC
    DECLARE QTY_ORDERED INTEGER;

    VALUES(ISSUE_SHIP_REQUEST(NROW.MAX_STOCKED - NROW.ON_HAND, NROW.PARTNO))
    INTO QTY_ORDERED;
  END
```

Example 3

Repeat the scenario in Example 2 except use a SELECT INTO statement instead of a VALUES INTO statement to invoke the user-defined function. This example also shows how to define the trigger as a statement trigger instead of a row trigger. For each row in the transition table that evaluates to true for the WHERE clause, a shipping request is issued for the part.

```
CREATE TRIGGER REORDER
  AFTER UPDATE OF ON_HAND, MAX_STOCKED ON PARTS
  REFERENCING NEW_TABLE AS NTABLE
  FOR EACH STATEMENT
  BEGIN ATOMIC
    DECLARE QTY_ORDERED INTEGER;
```

```

SELECT ISSUE_SHIP_REQUEST(MAX_STOCKED - ON_HAND, PARTNO)
FROM NTABLE
WHERE (ON_HAND < 0.10 * MAX_STOCKED)
INTO QTY_ORDERED;
END

```

Example 4

Assume that table EMPLOYEE contains column SALARY. Create a trigger, SAL_ADJ, that prevents an update to an employee's salary that exceeds 20% and signals such an error. Have the error that is returned with an SQLSTATE of '75001' and a description. This example shows that the SIGNAL statement is useful for restricting changes that violate business rules.

```

CREATE TRIGGER SAL_ADJ
AFTER UPDATE OF SALARY ON EMPLOYEE
REFERENCING OLD AS OLD_EMP
NEW AS NEW_EMP
FOR EACH ROW
WHEN (NEW_EMP.SALARY > (OLD_EMP.SALARY * 1.20))
BEGIN ATOMIC
SIGNAL SQLSTATE '75001' ('Invalid Salary Increase - Exceeds 20
END

```

Example 5

Assume that the following statements create a table, WEATHER (which stores temperature values in Fahrenheit), and a view, CELSIUS_WEATHER for users who prefer to work in Celsius instead of Fahrenheit:

```

CREATE TABLE WEATHER
(CITY VARCHAR(25),
TEMPF DECIMAL(5,2));
CREATE VIEW CELSIUS_WEATHER (CITY, TEMPC) AS
SELECT CITY, (TEMPF-32)/1.8
FROM WEATHER;

```

The following INSTEAD OF trigger is used on the CELSIUS_WEATHER view to convert Celsius values to Fahrenheit values and then insert the Fahrenheit value into the WEATHER table:

```

CREATE TRIGGER CW_INSERT INSTEAD OF INSERT
ON CELSIUS_WEATHER
REFERENCING NEW AS NEWCW
FOR EACH ROW
BEGIN ATOMIC
INSERT INTO WEATHER VALUES
(NEWCW.CITY,
1.8*NEWCW.TEMPC+32)
END;

```

Example 6

Create a before update trigger, STOCK_STATUS, using logic to record and track changes to stock prices.

Assume that the database contains two tables, CURRENTQUOTE and QUOTEHISTORY. CURRENTQUOTE has columns SYMBOL, QUOTE, and STATUS. QUOTEHISTORY has columns SYMBOL, QUOTE, and QUOTE_TIMESTAMP.

When the QUOTE column of CURRENTQUOTE is updated, the new quote must be copied, with a timestamp, to the QUOTEHISTORY table. Also, the STATUS column of CURRENTQUOTE must be updated to reflect whether the stock is:

- 1 Rising in value
- 2 At a new high for the year
- 3 Dropping in value
- 4 At a new low for the year
- 5 Steady in value

CREATE TRIGGER statements that accomplish these tasks are as follows:

Trigger STOCK_STATUS sets the status:

```
CREATE TRIGGER STOCK_STATUS
NO CASCADE BEFORE UPDATE OF QUOTE ON CURRENTQUOTE
REFERENCING NEW AS NEWQUOTE
OLD AS OLDQUOTE
FOR EACH ROW
BEGIN ATOMIC
SET NEWQUOTE.STATUS = CASE
WHEN NEWQUOTE.QUOTE >
(SELECT MAX(QUOTE)
FROM QUOTEHISTORY
WHERE SYMBOL = NEWQUOTE.SYMBOL
AND YEAR(QUOTE_TIMESTAMP) = YEAR(CURRENT DATE) )
THEN 'High'
WHEN NEWQUOTE.QUOTE <
(SELECT MIN(QUOTE)
FROM QUOTEHISTORY
WHERE SYMBOL = NEWQUOTE.SYMBOL
AND YEAR(QUOTE_TIMESTAMP) = YEAR(CURRENT DATE) )
THEN 'Low'
WHEN NEWQUOTE.QUOTE > OLDQUOTE.QUOTE THEN 'Rising'
WHEN NEWQUOTE.QUOTE < OLDQUOTE.QUOTE THEN 'Dropping'
WHEN NEWQUOTE.QUOTE = OLDQUOTE.QUOTE THEN 'Steady'
END;
END
```

Trigger RECORD_HISTORY records changes in the QUOTEHISTORY table:

```
CREATE TRIGGER RECORD_HISTORY
AFTER UPDATE OF QUOTE ON CURRENTQUOTE
REFERENCING NEW AS NEWQUOTE FOR EACH ROW
BEGIN ATOMIC
INSERT INTO QUOTEHISTORY VALUES (NEWQUOTE.SYMBOL,
NEWQUOTE.QUOTE,
CURRENT_TIMESTAMP);
END
```

Example 7

Create a before insert trigger, NEW_HIRED, that uses logic to illustrate the different scopes of a transition variable as compared to an SQL variable that is declared within the trigger body. Suppose that an EMPLOYEE table is defined as follows:

```
CREATE TABLE EMPLOYEE (EMPNO CHAR(6),
FIRSTNAME VARCHAR(32),
WORKDEPT CHAR(5),
NUM INTEGER)#
```

In the trigger NEW_HIRED, the correlation name for the transition variables for the new values is XYZ, and XYZ is also the label for a compound statement in which an SQL variable is defined. The table has a column named NUM, and the SQL variable is also named NUM. The reference to XYZ.NUM in the assignment statement refers to the SQL variable because that is the definition with the most local scope to the assignment statement.

```
CREATE TRIGGER NEW_HIRED
BEFORE INSERT ON EMPLOYEE
REFERENCING NEW AS XYZ
FOR EACH ROW
XYZ: BEGIN
DECLARE NUM INTEGER;
SET XYZ.NUM = XYZ.NUM + 1;
END XYZ#
```

Suppose that the following INSERT statement is issued:

```
INSERT INTO EMPLOYEE VALUES ('000001', 'RICK', 'DPT01', 10)#
```

The values in the table are the same as the values that were originally specified in the VALUES clause for the INSERT statement. This means that the NUM transition variable is not affected by the

assignment statement. The references to XYZ.NUM in the assignment statement resolve to the SQL variable NUM, rather than the transition variable NUM.

Issue the following SELECT statement to see the results after the INSERT statement runs:

```
SELECT * FROM EMPLOYEE#
```

The results are:

EMPNO	FIRSTNAME	WORKDEPT	NUM
000001	RICK	DPT01	10

Example 8

Create a BEFORE INSERT trigger using logic to enforce the rule that a class ends one hour after it begins if the ending time is not provided upon INSERT into CLASS_SCHED. Define the trigger to enforce an additional restriction that a class cannot end beyond 9 pm.

```
CREATE TRIGGER VALIDATE_SCHED
BEFORE INSERT ON CLASS_SCHED
REFERENCING NEW AS N
FOR EACH ROW
WHEN (N.ENDING IS NULL OR N.ENDING > '21:00')
VS: BEGIN
-- SUPPLY DEFAULT VALUE FOR ENDING TIME IF NULL
IF (N.ENDING IS NULL) THEN
SET N.ENDING = N.STARTING + 1 HOUR;
END IF;
-- ENSURE THAT CLASS DOES NOT END BEYOND 9PM
IF (N.ENDING > '21:00') THEN
SIGNAL SQLSTATE '80000'
SET MESSAGE_TEXT = 'CLASS ENDING TIME IS BEYOND 9 PM';
END IF;
END VS
```

Example 9: Change the trigger VALIDATE_SCHED to change the restriction so that classes cannot end beyond 7 PM. The OR REPLACE clause is added to the original CREATE TRIGGER statement, and the rule is changed to check for the ending time (N.ENDING > '19:00'). The CREATE TRIGGER statement replaces the existing definition of the trigger with the updated definition.

```
CREATE OR REPLACE TRIGGER VALIDATE_SCHED
BEFORE INSERT ON CLASSES
REFERENCING NEW AS N
FOR EACH ROW
-- TRIGGER WHEN CLAUSE
WHEN (N.ENDING IS NULL OR N.ENDING > '19:00')
VS: BEGIN
-- SUPPLY DEFAULT VALUE FOR ENDING TIME IF NULL
IF (N.ENDING IS NULL) THEN
SET N.ENDING = N.STARTING + 1 HOUR;
END IF;
-- ENSURE THAT CLASS DOES NOT END BEYOND 7 PM
IF (N.ENDING > '19:00') THEN
SIGNAL SQLSTATE '80000'
SET MESSAGE_TEXT = 'CLASS ENDING TIME IS BEYOND 7 PM';
END IF;
END VS
```

Related concepts

[Triggers \(Introduction to Db2 for z/OS\)](#)

[Naming conventions](#)

The rules for forming a name depend on the type of the object designated by the name.

Related tasks

[Creating a trigger \(Db2 Application programming and SQL\)](#)

[Converting existing triggers to support advanced capabilities \(Db2 Application programming and SQL\)](#)

CREATE TRIGGER statement (basic trigger)

The CREATE TRIGGER (basic) statement defines a basic trigger in a schema and builds a trigger package at the current server. Each time that the trigger activates, the trigger package executes one or more times.

For a description of the differences between basic and advanced triggers, see [Triggers \(Introduction to Db2 for z/OS\)](#).

Invocation for CREATE TRIGGER (basic)

The statement can be embedded in an application program or issued interactively. It is an executable statement that can be dynamically prepared only if DYNAMICRULES RUN behavior is in effect. For more information, see [“Authorization IDs and dynamic SQL” on page 94](#).

Authorization for CREATE TRIGGER (basic)

The privilege set that is defined below must include at least one of the following:

- The CREATEIN privilege on the schema
- SYSADM or SYSCTRL authority
- System DBADM
- Installation SYSOPR authority (when the current SQLID of the process is set to SYSINSTL)

In defining a trigger on a table, the privilege set that is defined below must include SYSADM authority or each of the following:

- The SELECT privilege on the table on which the trigger is defined, if the REFERENCING clause is included in the trigger definition
- The SELECT privilege on any table or view in the *search-condition* of the *triggered-action*
- The necessary privileges to invoke the triggered SQL statements in the triggered action
- The authorization to define a trigger on the table, which must include at least one of the following:
 - The TRIGGER privilege on the table on which the trigger is defined
 - The ALTER privilege on the table on which the trigger is defined
 - DBADM authority on the database that contains the table
 - SYSCTRL authority
 - Installation SYSOPR authority (when the current SQLID of the process is set to SYSINSTL)
 - System DBADM authority

If the database is implicitly created, the database privileges must be on the implicit database or on DSNDB04.

In defining a trigger on a view, the privilege set that is defined below must include SYSADM authority or each of the following:

- The SELECT privilege on the view on which the trigger is defined, if the REFERENCING clause is included in the trigger definition
- The SELECT privilege on any table or view in the *search-condition* of the *triggered-action*
- The necessary privileges to invoke the triggered SQL statements in the triggered action
- The authorization to define a trigger on the view, which must include at least one of the following:
 - Ownership of the view on which the trigger is defined
 - SYSCTRL authority
 - System DBADM authority

Privilege set: If the statement is embedded in an application program, the privilege set is the privileges that are held by the owner of the plan or package. If the owner is a role, the implicit schema match does not apply and this role needs to include one of the previously listed conditions.

If the statement is dynamically prepared and is not running in a trusted context for which the ROLE AS OBJECT OWNER clause is specified, the privilege set is the set of privileges that are held by the SQL authorization ID of the process. The specified trigger name can include a schema name (a qualifier). If the schema name is not the same as the SQL authorization ID of the process, one of the following conditions must be met:

- The privilege set includes SYSADM or SYSCTRL authority.
- The SQL authorization ID of the process has the CREATEIN privilege on the schema.

If the SECURED option is specified, at least one of the following privileges is required:

- SECADM authority
- CREATE_SECURE_OBJECT privilege

Note: If the SEPARATE SECURITY subsystem parameter is set to NO, SYSADM authority has implicit SECADM authority.

Syntax for CREATE TRIGGER (basic)

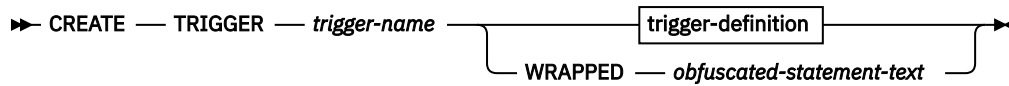

trigger-definition

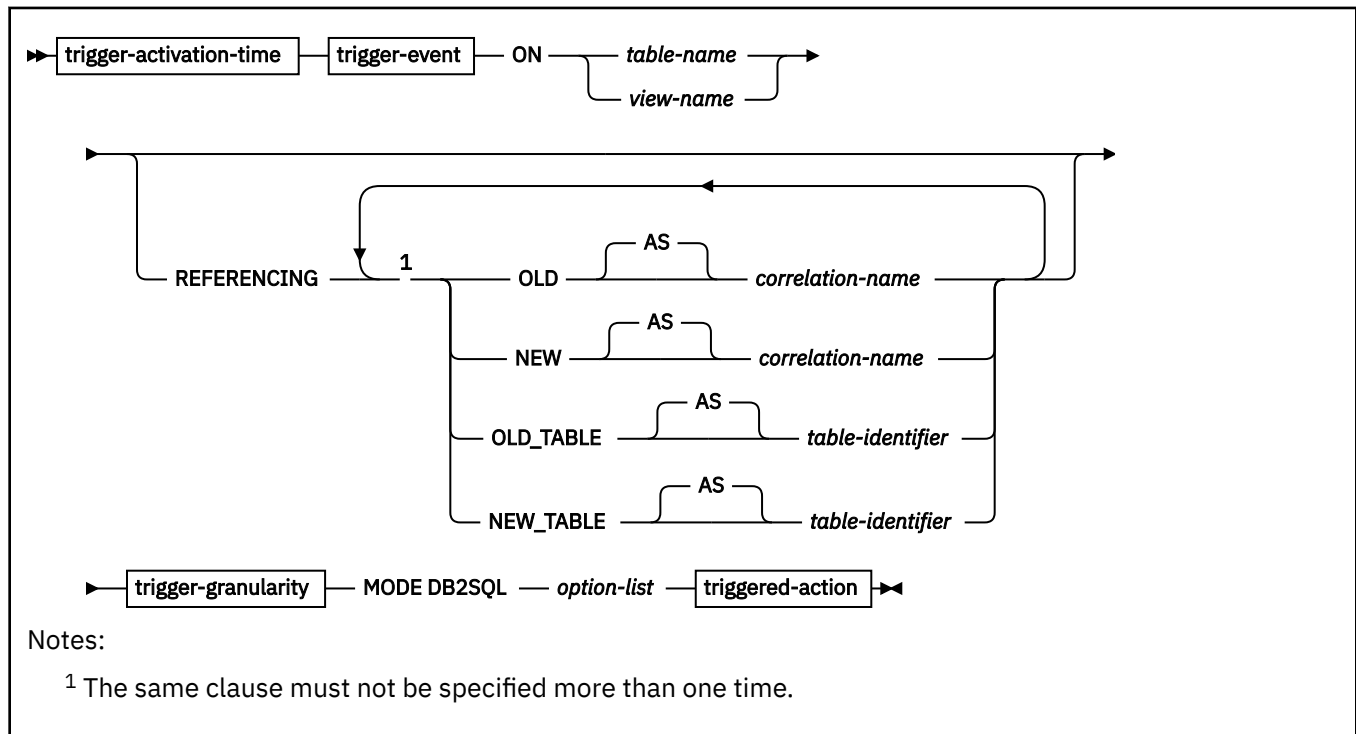

Notes:

¹ The same clause must not be specified more than one time.

trigger-activation-time

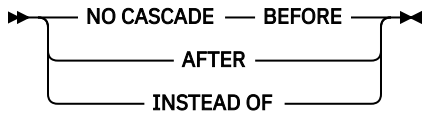

trigger-event

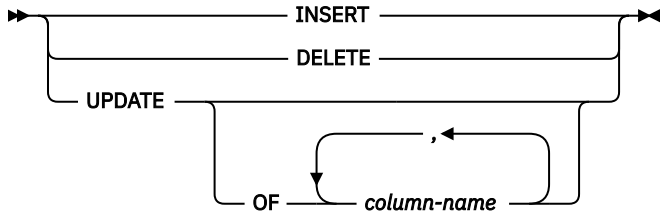

trigger-granularity

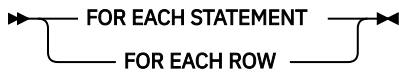

triggered-action

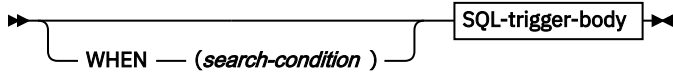

SQL-trigger-body

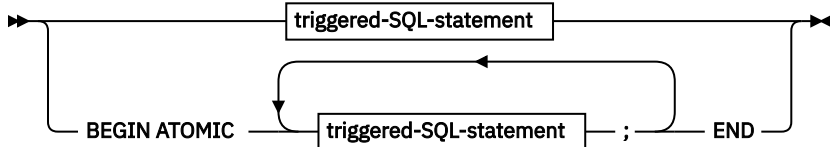

triggered-SQL-statement:

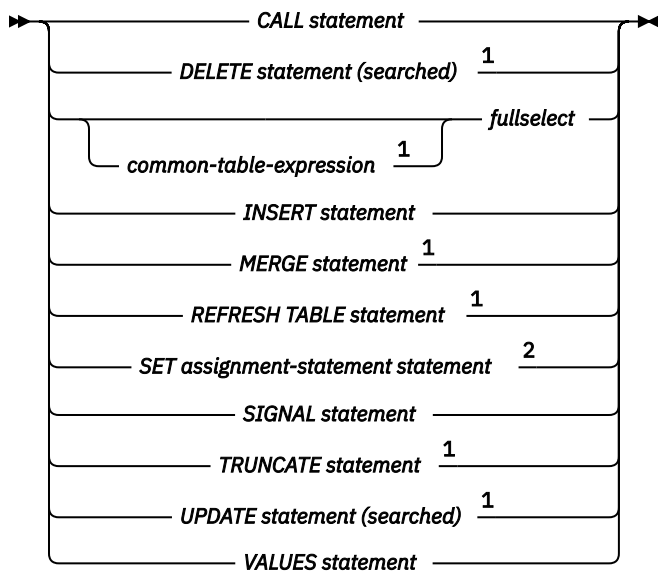

Notes:

- ¹ The statement is not allowed in an *SQL-trigger-body* for a BEFORE trigger.
- ² The target of a SET-assignment-statement statement must be a transition variable.

option-list:

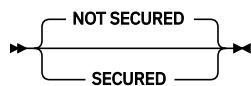

Description for CREATE TRIGGER (basic)

trigger-name

Names the trigger. The name, including the implicit or explicit schema name, must not identify a trigger that exists at the current server.

The name is also used to create the trigger package; therefore, the name must also not identify a package that is already described in the catalog. The schema name becomes the collection-id of the trigger package. Although *trigger-name* can be specified as an ordinary or delimited identifier, the name should conform to the rules for an ordinary identifier. Refer to [The implicitly created trigger package](#) for additional information.

The schema name can be 'SYSTOOLS' if the privilege set includes the SYSCTRL privilege. Otherwise, the schema name must not begin with 'SYS' unless the schema name is 'SYSADM', 'SYSIBMADM', or 'SYSPROC'.

NO CASCADE BEFORE

Specifies that the trigger is a before trigger. Db2 executes the triggered action before it applies any changes caused by an insert, delete, or update operation on the subject table. It also specifies that the triggered action does not activate other triggers because the triggered action of a before trigger cannot contain any updates, REFRESH TABLE, or TRUNCATE SQL statements.

BEFORE must not be specified when *view-name* is also specified. FOR EACH ROW must be specified for a BEFORE trigger.

AFTER

Specifies that the trigger is an after trigger. Db2 executes the triggered action after it applies any changes caused by an insert, delete, or update operation on the subject table. AFTER must not be specified if *view-name* is also specified.

INSTEAD OF

Specifies that the trigger is an instead of trigger. The associated triggered action replaces the action against the subject view. Only one INSTEAD OF trigger is allowed for each type of operation on a given subject view. Db2 executes the *triggered-action* instead of the insert, update, or delete operation on the subject view.

INSTEAD OF must not be specified when *table-name* is also specified. The WHEN clause can not be specified for an INSTEAD OF trigger. FOR EACH STATEMENT must not be specified for an INSTEAD OF trigger.

In the view definition, the non-numeric columns of the outermost SELECT list of the fullselect must use the same encoding scheme.

ON *table-name*

Identifies the subject table of the BEFORE or AFTER trigger definition. The name must identify a base table that exists at the current server. It must not identify a materialized query table, a clone table, a temporary table, an auxiliary table, an alias, a synonym, a real-time statistics table, an accelerator-only table, a catalog table, or a directory table.

ON *view-name*

Identifies the subject view of the INSTEAD OF trigger definition. The name must identify a view that exists at the current server.

view-name must not specify a view where any of the following conditions are true:

- The view is defined with the WITH CASCADED CHECK option (a symmetric view)
- The view on which a symmetric view has been defined
- The view references data that is encoded with different encoding schemes or CCSID values
- The view has a column that is a ROWID column
- The view has a column that is based on an underlying column of any of the following types:
 - A LOB, XML, or ROWID column
 - An identity column
 - A security label column
 - A row change timestamp column
 - A row-begin column
 - A row-end column
 - A transaction start ID column
- The view has columns that have field procedures
- All of the underlying tables of the view are catalog tables
- All of the underlying tables of the view are created global temporary tables
- All of the underlying tables of the view are clone tables
- The view has other views that are dependent on it

REFERENCING

Specifies the correlation names for the transition variables and the table names for the transition tables. For the rows in the subject table that are modified by the triggering SQL operation (insert, delete, or update), a correlation name identifies the columns of a specific row. *table-identifiers* identify the complete set of affected rows. Transition variables with XML types cannot be referenced inside of a trigger. If the column of a transition table is referenced, the data type of the column cannot be XML.

Each row that is affected by the triggering SQL operation is available to the triggered action by qualifying column names with *correlation-names* that are specified as follows:

OLD AS *correlation-name*

Specifies the correlation name that identifies the values in the row prior to the triggering SQL operation.

NEW AS *correlation-name*

Specifies the correlation name that identifies the values in the row as modified by the triggering SQL operation and by any assignment statement in a before trigger that has already been executed.

The complete set of rows that are affected by the triggering operation is available to the triggered action by using *table-identifiers* that are specified as follows:

OLD_TABLE AS *table-identifier*

Specifies the name of a temporary table that identifies the values in the complete set of rows that are modified rows by the triggering SQL operation prior to any actual changes.

NEW_TABLE AS *table-identifier*

Specifies the name of a temporary table that identifies the values in the complete set of rows as modified by the triggering SQL operation and by any assignment statement in a before trigger that has already been executed.

Only one OLD and one NEW *correlation-name* can be specified for a trigger. Only one OLD_TABLE and one NEW_TABLE *table-identifier* can be specified for a trigger. All of the *correlation-names* and *table-identifiers* must be unique from one another.

Table 222 on page 1775 summarizes the allowable combinations of transition variables and transition tables that you can specify for the various trigger types. The OLD *correlation-name* and the OLD_TABLE *table-identifier* are valid only if the triggering event is either a delete operation or an update operation. For a delete operation, the OLD *correlation-name* captures the values of the columns in the deleted row, and the OLD_TABLE *table-identifier* captures the values in the set of deleted rows. For an update operation, the OLD *correlation-name* captures the values of the columns of a row before the update operation, and the OLD_TABLE *table-identifier* captures the values in the set of updated rows.

The NEW *correlation-name* and the NEW_TABLE *table-identifier* are valid only if the triggering event is either an insert operation or an update operation. For both operations, the NEW *correlation-name* captures the values of the columns in the inserted or updated row and the NEW_TABLE *table-identifier* captures the values in the set of inserted or updated rows. For BEFORE triggers, the values of the updated rows include the changes from any assignment statements in the triggered action of BEFORE triggers.

Table 222. Allowable combinations of attributes in a trigger definition

Granularity	Activation time	Triggering SQL operation	Transition variables allowed“1” on page 1775	Transition tables allowed“1” on page 1775
FOR EACH ROW	BEFORE	DELETE	OLD	None
		INSERT	NEW	None
		UPDATE	OLD, NEW	None
	AFTER	DELETE	OLD	OLD_TABLE
		INSERT	NEW	NEW_TABLE
		UPDATE	OLD, NEW	OLD_TABLE, NEW_TABLE
	INSTEAD OF	DELETE	OLD	OLD_TABLE
		INSERT	NEW	NEW_TABLE
		UPDATE	OLD, NEW	OLD_TABLE, NEW_TABLE
FOR EACH STATEMENT	AFTER	DELETE	None	OLD_TABLE
		INSERT	None	NEW_TABLE
		UPDATE	None	OLD_TABLE, NEW_TABLE

Note:

1. If a transition table or variable is referenced where it is not allowed, an error is returned.

A transition variable that has a character data type inherits the subtype and CCSID of the column of the subject table. During the execution of the triggered action, the transition variables are treated like host variables. Therefore, character conversion might occur. However, unlike a host variable, a transition variable can have the bit data attribute, and character conversion never occurs for bit data. A transition variable is considered to be bit data if the column of the table to which it corresponds is bit data.

You cannot modify a transition table; transition tables are read-only. Although a transition table does not inherit any edit or validation procedures from the subject table, it does inherit the encoding scheme and field procedures of the subject table.

The scope of each *correlation-name* and each *table-identifier* is the entire trigger definition.

trigger-granularity

FOR EACH ROW or FOR EACH STATEMENT

Specifies the conditions for which Db2 executes the triggered action.

FOR EACH ROW

Specifies that Db2 executes the triggered action for each row of the subject table that the triggering SQL operation modifies. If the triggering SQL operation does not modify any rows, the triggered action is not executed..

FOR EACH STATEMENT

Specifies that Db2 executes the triggered action only one time for the triggering operation. Even if the triggering operation does not modify or delete any rows, the triggered action is executed one time.

FOR EACH STATEMENT must not be specified for a BEFORE or INSTEAD OF trigger.

MODE DB2SQL

Indicates that a basic trigger is to be created.

NOT SECURED or SECURED

Specifies whether the trigger is considered secure. NOT SECURED is the default.

SECURED

Specifies the trigger is considered secure.

SECURED must be specified for a trigger if its subject table is using row access control or column access control. SECURED must also be specified for a trigger that is created for a view and one or more of the underlying tables in the view definition is using row access control or column access control.

NOT SECURED

Specifies the trigger is considered not secure.

NOT SECURED must not be specified for a trigger whose subject table is using row access control or column access control. NOT SECURED must also not be specified for a trigger that is created for a view and one or more of the underlying tables in the view definition is using row access control or column access control.

trigger-event

Specifies that the triggered action that is associated with the trigger is to be executed when the trigger event is applied to the subject table or view.

INSERT

Specifies that the trigger is an insert trigger. Db2 executes the triggered action whenever there is an insert operation on the subject table. However, if the insert trigger is defined on any explain table, and the insert operation was caused by Db2 adding a row to the table, the triggered action is not to be executed.

DELETE

Specifies that the trigger is a delete trigger. Db2 executes the triggered action whenever there is a delete operation on the subject table.

UPDATE

Specifies that the trigger is an update trigger. Db2 executes the triggered action whenever there is an update operation on the subject table.

If you do not specify a list of column names, an update operation on any column of the subject table, including columns that are subsequently added with the ALTER TABLE statement, activates the triggered action.

OF *column-name*,...

Each *column-name* that you specify must be a column of the subject table and must appear in the list only once. An update operation on any of the listed columns activates the triggered action.

UPDATE OF *column-name* cannot be specified for an INSTEAD OF trigger.

triggered-action

Specifies the action to be performed when the trigger is activated. The *triggered-action* is composed of one or more SQL statements and an optional condition that controls whether the statements are executed.

WHEN (*search-condition*)

Specifies a condition that evaluates to true, false, or unknown. The triggered SQL statements are executed only if the *search-condition* evaluates to true. If the WHEN clause is omitted, the associated SQL statements are always executed.

The WHEN clause must not be specified for an INSTEAD OF trigger.

SQL-trigger-body

Specifies the SQL statements that are to be executed for the triggered action. Only certain SQL statements can be specified in the SQL-trigger-body.

triggered-SQL-statement

Specifies the SQL statements that can be specified as the only statement in a trigger body.

BEGIN ATOMIC triggered-SQL-statement,... END

Specifies a list of SQL statements that are to be executed for the triggered action. The statements are executed in the order in which they are specified.

Only certain SQL statements can be specified in the *SQL-trigger-body*.

The trigger body must not contain a statement that is not supported. Table 223 on page 1777 shows the list of allowable SQL statements, which differs depending on whether the trigger is being defined as BEFORE, AFTER, or INSTEAD OF. An 'X' in the table indicates that the statement is valid.

Table 223. Allowable SQL statements

SQL statement	Trigger activation time		
	BEFORE	AFTER	INSTEAD OF
CALL	X	X	X
DELETE (searched)		X	X
fullselect	X	X	X
INSERT		X	X
MERGE		X	X
REFRESH TABLE		X	X
SET transition variable	X		
SIGNAL	X	X	X
TRUNCATE		X	X
UPDATE (serached)		X	X
VALUES	X	X	X

The statements in the triggered action have these restrictions:

- They must not refer to host variables, parameter markers, undefined transition variables, or declared temporary tables.
- They must only refer to a table or view that is at the current server.
- They must only invoke a stored procedure or user-defined function that is at the current server. An invoked routine can, however, access a server other than the current server.
- They must not contain a fullselect that refers to the subject table if the trigger is defined as BEFORE.
- They must not modify a column that is part of a BUSINESS_TIME period.
- If the trigger is a before trigger:
 - The trigger body must not contain a DELETE, INSERT, MERGE, REFRESH TABLE, TRUNCATE, UPDATE statement, or SELECT FROM *data-change-statement*, and must not reference a procedure or function that is defined as MODIFIES SQL DATA.
 - The trigger body must not, directly or indirectly, issue a CALL statement for a procedure containing one of the following statements:
 - ALTER
 - COMMENT
 - CREATE
 - DELETE
 - DROP

- EXCHANGE
- GRANT
- LABEL
- LOCK TABLE
- MERGE
- REFRESH TABLE
- RENAME
- REVOKE
- TRUNCATE
- UPDATE

A CREATE TRIGGER statement cannot contain a hexadecimal graphic string (GX) constant.

The triggered action can refer to the values in the set of affected rows. This action is supported through the use of transition variables and transition tables.

All tables, views, aliases, sequences, roles, user-defined data types, user-defined functions, and procedures referenced in the *triggered-action* must exist at the current server when the version of the trigger is defined. The table or view that an alias refers to must also exist when the version of the trigger is defined.

WRAPPED *obfuscated-statement-text*

Specifies the encoded definition of the trigger. A CREATE TRIGGER statement can be encoded using the WRAP scalar function.

WRAPPED must not be specified on a static CREATE statement.

Notes for CREATE TRIGGER (basic)

Owner privileges:

When an INSTEAD OF trigger is defined, the associated privilege (INSERT, UPDATE, or DELETE on the view) is given to the owner of the view. The owner is granted the privilege with the ability to grant that privilege to others. For more information about ownership of an object, see [“Authorization, privileges, permissions, masks, and object ownership”](#) on page 90.

Execution authorization:

The user executing the triggering SQL operation does not need authority to execute a *SQL-trigger-body*. An *SQL-trigger-body* executes using the authority of the owner of the trigger.

Activating a trigger:

Only insert, delete, or update operations can activate a trigger. The activation of a trigger might cause trigger cascading. *Trigger cascading* is the result of the activation of one trigger that executes SQL statements that cause the activation of other triggers or even the same trigger again. The triggered actions might also cause updates as a result of the original modification, which can result in the activation of additional triggers. With trigger cascading, a significant chain of triggers might be activated, causing a significant change to the database as a result of a single insert, delete, or update operation.

Loading a table with the LOAD utility does not activate any triggers that are defined for the table if the SHRLEVEL NONE option is specified or accepted as the default. If the LOAD statement includes the SHRLEVEL CHANGE option, triggers are activated when loading a table with the LOAD utility.

Adding triggers to enforce constraints:

Adding a trigger on a table that already has rows in it will not cause the *triggered-action* to be executed. Thus, if the trigger is designed to enforce constraints on the data in the table, the data in the existing rows might not satisfy those constraints.

Multiple triggers:

Multiple triggers that have the same triggering SQL operation and activation time can be defined on a table. The triggers are activated in the order in which they were created. For example, the trigger that was created first is executed first; the trigger that was created second is executed second.

Transition variables and transition tables:

The *triggered-action* can refer to the values in the set of affected rows. This action is supported through the use of transition variables and transition tables.

A transition variable has the same name, data type, and nullability attribute as the corresponding column of the table that the trigger is defined on. A transition variable contains the value of a column in an affected row. A transition variable is qualified by a correlation name that identifies whether the reference is to the old value (before the update) or the new value (after the update). A transition variable can be referenced in the search condition, or in an SQL statement in the trigger body, wherever a variable would be allowed if the reference was made outside the body of a trigger. A new transition variable can be assigned a value in a before update or insert trigger. The values of the updated rows include the changes from any assignments to transition variables in the *triggered-action* of a before trigger.

A transition table contains the complete set of affected rows: either the old values (before the update) or the new values (after the update). A transition table is read-only, and can be referenced in the *triggered-action* of an after or instead of trigger. A column of a transition table has the same name, data type, and null attribute as the corresponding column of the table that the trigger is defined on. A transition table is referenced using an associated table identifier that allows the complete set of affected rows to be treated as a table. A transition table can be referenced in a search condition, or in an SQL statement in the trigger body, wherever a table would be allowed if the reference was made outside the body of a trigger. In addition, a transition table can be passed as an argument to a user-defined function or procedure, specifying the TABLE keyword before the table identifier for the transition table. When the function or procedure is invoked, a table locator is passed for the transition table.

A transition variable or transition table is not affected after being returned from a procedure invoked from within a triggered action regardless of whether the corresponding parameter was defined in the CREATE PROCEDURE statement as IN, INOUT, or OUT.

Considerations for *table-locator-reference* elements:

table-locator-reference must not be specified in the body of a trigger.

Considerations for implicitly hidden columns:

In the body of a trigger, a transition variable that corresponds to an implicitly hidden column can be referenced. A transition table, that corresponds to a table with an implicitly hidden column, includes that column as part of the transition table. Likewise, a transition variable will exist for the column that is defined as implicitly hidden. A transition variable that corresponds to an implicitly hidden column can be referenced in the body of a trigger.

Identifier resolution:

Names that are the same should be explicitly qualified. Qualifying a name clearly indicates whether the name refers to a column, a transition variable, or a global variable. If the name is not qualified or is qualified but is still ambiguous, the following rules describe how the name is resolved. If correlation names are specified for both old and new transition variables, a reference to a transition variable must be qualified with the associated correlation name. The name is resolved by checking for a match in the following order:

- If the tables and views specified in the trigger body exist at the time the trigger is created, the name is first checked as a column name at the current server. If the name is found as a column name, but the privilege set that is used to issue the CREATE statement does not have the proper authority to access the table or view, an error is returned.
- If the name is not found as a column, the name is checked as a transition variable name.
- If the name is not found as a transition variable, the name is checked as a global variable.
- If the name is still not resolved, an error is returned.

Considerations for transition variables in AFTER and INSTEAD OF triggers:

Transition variables cannot be modified in an AFTER or INSTEAD OF trigger.

Invalidation of packages:

This statement might invalidate all packages that depend on target objects, and sometimes other related objects through cascading effects, depending on the clauses and keywords specified and other factors. For more information, see [Changes that invalidate packages \(Db2 Application programming and SQL\)](#).

Invalidation of cached dynamic SQL statements:

This statement might invalidate cached dynamic SQL statements that depend on target objects, and sometimes other related objects through cascading effects. For more information, see [Invalidation of cached dynamic statements \(Db2 Performance\)](#).

Considerations for INSTEAD OF triggers:

The addition of an INSTEAD OF trigger for a view affects the read only characteristic of the view. If a read-only view has a dependency relationship with an INSTEAD OF trigger, the type of operation that is defined for the INSTEAD OF trigger defines whether the view is deletable, insertable, or updatable.

The creation of an INSTEAD OF trigger causes dependent packages, plans, and statements in the dynamic statement cache to be marked invalid if the view definition is not read-only.

The initial values for new transition variables or new transition table columns that are visible in an INSTEAD OF INSERT trigger are set as follows:

- If a value is explicitly specified for a column in the insert operation, the corresponding new transition variable is that explicitly specified value.
- If a value is not explicitly specified for a column in the insert operation or the DEFAULT clause is specified, the corresponding new transition variable is:
 - the default value of the underlying table column if the view column is updatable (without the INSTEAD OF trigger)
 - otherwise, the null value

If a view column is not nullable and does not have a default, the value must be explicitly specified in the insert operation.

The initial values for new transition variables that are visible in an INSTEAD OF UPDATE trigger are set as follows:

- If a value is explicitly specified for a column in the update operation, the corresponding new transition variable is that explicitly specified value
- If the DEFAULT clause is explicitly specified for a column in the update operation, the corresponding new transition variable is:
 - the default value of the underlying table column if the view column is updatable (without the INSTEAD OF trigger)
 - otherwise, the null value

If a view column is not nullable and does not have a default, the value must be explicitly specified in the update operation.

- Otherwise, the corresponding new transition variable is the existing value of the column in the row.

Considerations for a MERGE statement:

The MERGE statement can execute insert, delete, and update operations. The applicable triggers are activated for the MERGE statement for the data change operations that are executed.

Considerations for triggers that are defined on tables that contain XML columns:

Although a trigger can be defined on a table that contains an XML column:

- An XML column cannot be referenced with a trigger transition variable in the trigger body.
- An XML column of a transition table cannot be referenced in the trigger body.

Creating a trigger with the SECURED option:

Typically, the security administrator will examine the data that is accessed by a trigger, ensure that it is secure, and grant the CREATE_SECURE_OBJECT privilege to someone who requires the privileges to create a secured trigger. After the trigger is created, the security administrator will revoke the CREATE_SECURE_OBJECT privilege from the owner of the trigger.

The trigger is considered secure after the CREATE TRIGGER statement is executed. Db2 treats the SECURED attribute as an assertion that declares that the user has established an audit procedure for all activities in the trigger body. If a secure trigger references user-defined functions, Db2 assumes those functions are secure without validation. If those functions can access sensitive data, the user with SECADM authority needs to ensure that those functions are allowed to access that data and that an audit procedure is in place for all versions of those functions, and that all subsequent ALTER FUNCTION statements or changes to external packages are being reviewed by this audit process.

A trigger must be secure if its subject table is using row access control or column access control. SECURED must also be specified for a trigger that is created for a view and one or more of the underlying tables in the view definition is using row access control or column access control.

Creating a trigger with the NOT SECURED option:

The CREATE TRIGGER statement returns an error if the subject table of the trigger is using row access control or column access control, or if the trigger is for a view and one or more of the underlying tables in the view definition is using row access control or column access control.

Row and column access control that is not enforced for transition variables and transition tables:

If row access control or column access control is enforced for the subject table of the trigger, row permissions and column masks are not applied to the initial values of transition variables and transition tables. Row access control and column access control is enforced for the triggering table, but is ignored for transition variables and transition tables that are referenced in the body of the trigger body or are passed as arguments to user-defined functions that are invoked in the body of the trigger. To ensure that there are no security concerns for SQL statements accessing sensitive data in transition variables and transition tables in the trigger action, the trigger must be created with the SECURED option. If a trigger is not secure, the CREATE TRIGGER statement returns an error.

Restrictions involving pending definition changes:

CREATE TRIGGER is not allowed if the trigger is defined on a table for which there are pending definition changes.

Considerations for the special plan, statement, and function tables for EXPLAIN:

You can create a trigger on PLAN_TABLE, DSN_STATEMENT_TABLE, or DSN_FUNCTION_TABLE. However, insert triggers that are defined on these tables are not activated when Db2 adds rows to the tables.

Dependent objects:

A trigger is dependent on the triggering table and objects that are referenced in the trigger body.

Adding a column to a subject table or a table referenced in the triggered-action:

If a column is added to the subject table after triggers have been defined, the following rules apply:

- If the trigger is an update trigger that was defined without an explicit list of column names, an update to the new column activates the trigger.
- If the subject table is referenced in the *triggered-action*, the new column is not accessible to the SQL statements until the trigger package is rebound.
- The OLD_TABLE and the NEW_TABLE transition tables contain the new column, but the column cannot be referenced unless the trigger is re-created. If the transition tables are passed to a user-defined function or a stored procedure, the user-defined function or stored procedure must be re-created with the new definition of the table (that is, the function or procedure must be dropped and re-created), and the package for the user-defined function or stored procedure must be rebound.

If a column is added to any table that is referenced in the *triggered-action*, the new column is not accessible to the SQL statements until the trigger package is rebound.

Dropping a column from a subject table or a table referenced in the *triggered-action*:

A column cannot be dropped from a table for which a trigger is defined.

Altering the attributes of a column that the triggered action references:

If a column is altered in the table on which the trigger is defined (the subject table), the alter is processed, and the dependent trigger packages are invalidated.

Renaming the table for which the trigger is defined, or tables referenced in the *triggered-action*:

You cannot rename a table for which a trigger is defined (the subject table). Except for the subject table, you can rename any table to which the SQL statements in the triggered action refer. After renaming such a table, drop the trigger and then re-create the trigger so that it refers to the renamed table.

Dropping the table or view for which a trigger is defined:

If the table or view that a trigger is defined on is dropped, the trigger is also dropped.

Effects of dropping or revoking privileges on an object referenced in the *triggered-action*:

Dropping an object that is referenced in the body of a trigger, or revoking a privilege to an object that is referenced in the body of a trigger, might have the following results:

- Dropping any table, view, alias, or index that is referenced or used within the SQL statements in the triggered action causes the trigger and its package to be invalidated.
- Dropping a synonym that is referenced does not have any effect on the trigger or its package.
- Dropping a user-defined function that is referenced by the SQL statements in the triggered action is not allowed. An error occurs.
- Dropping a sequence that is referenced by the SQL statements in the triggered action is not allowed. An error occurs.
- Revoking a privilege on which the trigger depends causes the trigger and its package to be invalidated. If the appropriate privilege does not exist when the trigger package is rebound, the SQL statement that references the object fails.

Error handling in triggers:

A trigger can return errors, like other SQL statements. Applications need to account for the possible errors that can be expected when a trigger is invoked.

Triggers and global variables:

The content of a global variable that is referenced by a trigger is inherited from the triggering SQL operation (delete, insert, or update).

Special registers:

The values of the special registers that are used in the trigger body are determined when the trigger is activated. The value of the CURRENT PACKAGESET special register is set to the schema name of the trigger, and the values of the other special registers are inherited from the triggering SQL operation (insert, update, or delete). Special register values are saved when a trigger is activated and are restored on return from the trigger. The CURRENT DATE, CURRENT TIME, and CURRENT TIMESTAMP special registers are not restored on return from the trigger.

Result sets for stored procedures:

If a trigger invokes a stored procedure that returns result sets, the application that activated the trigger cannot access those result sets.

Transaction isolation:

All of the statements in the *SQL-trigger-body* run under the isolation level that is in effect for the trigger.

Limiting processor time:

The Db2 resource limit facility allows you to specify the maximum amount of processor time for a dynamic, manipulative SQL statement such as SELECT or SQL data change statements. The execution of a trigger is counted as part of the triggering SQL statement.

Errors binding triggers:

When a CREATE TRIGGER statement is bound, the SQL statements within the triggered action might not be fully parsed. Syntax errors in those statements might not be caught until the CREATE TRIGGER statement is executed.

Characteristics of the package that is generated for a trigger:

The package that is associated with the trigger is named as follows:

- *location* is set to the value of the CURRENT SERVER special register.
- *collection-id* (schema) for the package is the same as the schema qualifier of the trigger.
- *package-id* is the same as the name of the trigger.
- *version-id* is an empty string.

Db2 creates the trigger package with the following initial attributes (some of these attributes can be modified using the REBIND TRIGGER PACKAGE command):

- ACTION(ADD)
- ARCHIVESENSITIVE(YES)
- BUSTIMESENSITIVE(YES)
- CURRENTDATA(NO)
- DBPROTOCOL(DRDA)
- DEGREE(1)
- DESCSTAT(value from the DESCSTAT subsystem parameter)
- DYNAMICRULES(BIND)
- ENABLE(*)
- ENCODING(0)
- EXPLAIN(NO)
- FLAG(I)
- ISOLATION(CS)
- REOPT(NONE)
- NODEFER(PREPARE)
- OPTHINT
- OWNER(authorization ID) or ROLE
- PATH(path)
- RELEASE(COMMIT)
- ROUNDING(value from the CURRENT DECFLOAT ROUNDING MODE special register)
- SQLERROR(NOPACKAGE)
- SYSTIMESENSITIVE(YES)
- QUALIFIER(authorization ID)
- VALIDATE(BIND)

The values of OWNER, QUALIFIER, and PATH are set depending on whether the CREATE TRIGGER statement is embedded in a program or issued interactively. If the statement is embedded in a program, OWNER and QUALIFIER are the owner and qualifier of the package or plan. PATH is the value from the PATH bind option. If the statement is issued interactively, both OWNER and QUALIFIER are the SQL authorization ID. PATH is the value in the CURRENT PATH special register.

Multiple versions of a trigger package are not allowed. Use the REBIND TRIGGER PACKAGE command to explicitly rebind the basic trigger package. To specify the name of a trigger package for the bind commands, the trigger name must conform to the rules for an ordinary identifier.

A trigger package becomes invalid if an object or privilege on which it depends is dropped or revoked. The next time that the trigger is activated, Db2 attempts to rebind the invalid trigger package. If the automatic rebind is unsuccessful, the trigger package remains invalid.

You cannot create another package from the trigger package, such as with the BIND COPY command. The only way to drop a trigger package is to drop the trigger or the subject table. Dropping the trigger drops the trigger package; dropping the subject table drops the trigger and the trigger package.

Each time that the trigger activates, the trigger package executes one or more times.

Considerations for SQL processor programs:

SQL processor programs, such as SPUFI, the command line processor, and DSNTEP2, might not correctly parse SQL statements in the triggered action that are ended with semicolons. These processor programs accept multiple SQL statements, each separated with a terminator character, as input. Processor programs that use a semicolon as the SQL statement terminator can truncate a CREATE TRIGGER statement with embedded semicolons and pass only a portion of it to Db2. Therefore, you might need to change the SQL terminator character for these processor programs. For information on changing the terminator character for SPUFI and DSNTEP2, see [Setting the SQL terminator character in a SPUFI input data set \(Db2 Application programming and SQL\)](#) and [DSNTEP2 and DSNTEP4 sample programs \(Db2 Application programming and SQL\)](#).

Application compatibility level:

The SQL statements in the trigger body must conform to the behavior specified by the application compatibility option in effect. The application compatibility value used to process the trigger is recorded in the APPLCOMPAT column of the SYSIBM.SYSPACKAGE catalog table.

Alternative syntax and synonyms:

To provide compatibility with previous releases of Db2 or other products in the Db2 family, Db2 supports the following keywords:

- OLD TABLE as a synonym for OLD_TABLE
- NEW TABLE as a synonym for NEW_TABLE

Obfuscated statements:

A CREATE TRIGGER statement can be executed in obfuscated form. In an obfuscated statement, only the trigger name and the WRAPPED keyword are readable. The rest of the statement is encoded in such a way that it is not readable but can be decoded by a database server that supports obfuscated statements. The WRAP scalar function produces obfuscated statements. Any debug options that are specified when the trigger is created from an obfuscated statement are ignored.

Examples for CREATE TRIGGER (basic)

Example 1

Create two triggers that track the number of employees that a company manages. The subject table is the EMPLOYEE table, and the triggers increment and decrement a column with the total number of employees in the COMPANY_STATS table. The tables have these columns:

EMPLOYEE table: ID, NAME, ADDRESS, and POSITION

COMPANY_STATS table: NBEMP, NBPRODUCT, and REVENUE

This example shows the use of transition variables in a row trigger to maintain summary data in another table.

Create the first trigger, NEW_HIRE, so that it increments the number of employees each time a new person is hired; that is, each time a new row is inserted into the EMPLOYEE table, increase the value of column NBEMP in table COMPANY_STATS by 1.

```
CREATE TRIGGER NEW_HIRE
  AFTER INSERT ON EMPLOYEE
  FOR EACH ROW MODE DB2SQL
  BEGIN ATOMIC
    UPDATE COMPANY_STATS SET NBEMP = NBEMP + 1;
  END
```

Create the second trigger, FORM_EMP, so that it decrements the number of employees each time an employee leaves the company; that is, each time a row is deleted from the table EMPLOYEE, decrease the value of column NBEMP in table COMPANY_STATS by 1.

```
CREATE TRIGGER FORM_EMP
  AFTER DELETE ON EMPLOYEE
  FOR EACH ROW MODE DB2SQL
  BEGIN ATOMIC
    UPDATE COMPANY_STATS SET NBEMP = NBEMP - 1;
  END
```

Example 2

Create a trigger, REORDER, that invokes user-defined function ISSUE_SHIP_REQUEST to issue a shipping request whenever a parts record is updated and the on-hand quantity for the affected part is less than 10% of its maximum stocked quantity. User-defined function ISSUE_SHIP_REQUEST orders a quantity of the part that is equal to the part's maximum stocked quantity minus its on-hand quantity; the function also ensures that the request is sent to the appropriate supplier.

The parts records are in the PARTS table. Although the table has more columns, the trigger is activated only when columns ON_HAND and MAX_STOCKED are updated.

```
CREATE TRIGGER REORDER
  AFTER UPDATE OF ON_HAND, MAX_STOCKED ON PARTS
  REFERENCING NEW AS NROW
  FOR EACH ROW
  MODE DB2SQL
  WHEN (NROW.ON_HAND < 0.10 * NROW.MAX_STOCKED)
  BEGIN ATOMIC
    VALUES(ISSUE_SHIP_REQUEST(NROW.MAX_STOCKED - NROW.ON_HAND, NROW.PARTNO));
  END
```

Example 3

Repeat the scenario in *Example 2* except use a fullselect instead of a VALUES statement to invoke the user-defined function. This example also shows how to define the trigger as a statement trigger instead of a row trigger. For each row in the transition table that evaluates to true for the WHERE clause, a shipping request is issued for the part.

```
CREATE TRIGGER REORDER
  AFTER UPDATE OF ON_HAND, MAX_STOCKED ON PARTS
  REFERENCING NEW_TABLE AS NTABLE
  FOR EACH STATEMENT MODE DB2SQL
  BEGIN ATOMIC
    SELECT ISSUE_SHIP_REQUEST(MAX_STOCKED - ON_HAND, PARTNO)
    FROM NTABLE
    WHERE (ON_HAND < 0.10 * MAX_STOCKED);
  END
```

Example 4

Assume that table EMPLOYEE contains column SALARY. Create a trigger, SAL_ADJ, that prevents an update to an employee's salary that exceeds 20% and signals such an error. Have the error that is returned with an SQLSTATE of '75001' and a description. This example shows that the SIGNAL statement is useful for restricting changes that violate business rules.

```
CREATE TRIGGER SAL_ADJ
  AFTER UPDATE OF SALARY ON EMPLOYEE
  REFERENCING OLD AS OLD_EMP
  NEW AS NEW_EMP
  FOR EACH ROW MODE DB2SQL
  WHEN (NEW_EMP.SALARY > (OLD_EMP.SALARY * 1.20))
  BEGIN ATOMIC
    SIGNAL SQLSTATE '75001' ('Invalid Salary Increase - Exceeds 20');
  END
```

Example 5

Assume that the following statements create a table, WEATHER (which stores temperature values in Fahrenheit), and a view, CELSIUS_WEATHER for users who prefer to work in Celsius instead of Fahrenheit:

```

CREATE TABLE WEATHER
(CITY VARCHAR(25),
TEMPF DECIMAL(5,2));
CREATE VIEW CELSIUS_WEATHER (CITY, TEMPC) AS
SELECT CITY, (TEMPF-32)/1.8
FROM WEATHER;

```

The following INSTEAD OF trigger is used on the CELSIUS_WEATHER view to convert Celsius values to Fahrenheit values and then insert the Fahrenheit value into the WEATHER table:

```

CREATE TRIGGER CW_INSERT INSTEAD OF INSERT
ON CELSIUS_WEATHER
REFERENCING NEW AS NEWCW
FOR EACH ROW MODE DB2SQL
BEGIN ATOMIC
    INSERT INTO WEATHER VALUES
        (NEWCW.CITY,
         1.8*NEWCW.TEMPC+32);
END

```

Example 6

Consider an application that records and tracks changes to stock prices. The database contains two tables, CURRENTQUOTE and QUOTEHISTORY. CURRENTQUOTE has columns SYMBOL, QUOTE, and STATUS. QUOTEHISTORY has columns SYMBOL, QUOTE, and QUOTE_TIMESTAMP.

When the QUOTE column of CURRENTQUOTE is updated, the new quote must be copied, with a timestamp, to the QUOTEHISTORY table. Also, the STATUS column of CURRENTQUOTE must be updated to reflect whether the stock is:

- 1 Rising in value
- 2 At a new high for the year
- 3 Dropping in value
- 4 At a new low for the year
- 5 Steady in value

CREATE TRIGGER statements that accomplish these tasks are as follows:

Trigger STOCK_STATUS sets the status:

```

CREATE TRIGGER STOCK_STATUS
NO CASCADE BEFORE UPDATE OF QUOTE ON CURRENTQUOTE
REFERENCING NEW AS NEWQUOTE
OLD AS OLDQUOTE
FOR EACH ROW MODE DB2SQL
BEGIN ATOMIC
    SET NEWQUOTE.STATUS = CASE
        WHEN NEWQUOTE.QUOTE >
            (SELECT MAX(QUOTE)
             FROM QUOTEHISTORY
             WHERE SYMBOL = NEWQUOTE.SYMBOL
              AND YEAR(QUOTE_TIMESTAMP) = YEAR(CURRENT DATE) )
        THEN 'High'
        WHEN NEWQUOTE.QUOTE <
            (SELECT MIN(QUOTE)
             FROM QUOTEHISTORY
             WHERE SYMBOL = NEWQUOTE.SYMBOL
              AND YEAR(QUOTE_TIMESTAMP) = YEAR(CURRENT DATE) )
        THEN 'Low'
        WHEN NEWQUOTE.QUOTE > OLDQUOTE.QUOTE THEN 'Rising'
        WHEN NEWQUOTE.QUOTE < OLDQUOTE.QUOTE THEN 'Dropping'
        WHEN NEWQUOTE.QUOTE = OLDQUOTE.QUOTE THEN 'Steady'
    END;
END

```

Trigger RECORD_HISTORY records changes in the QUOTEHISTORY table:

```

CREATE TRIGGER RECORD_HISTORY
AFTER UPDATE OF QUOTE ON CURRENTQUOTE
REFERENCING NEW AS NEWQUOTE FOR EACH ROW MODE DB2SQL

```

```
BEGIN ATOMIC
INSERT INTO QUOTEHISTORY VALUES (NEWQUOTE.SYMBOL,
NEWQUOTE.QUOTE,
CURRENT TIMESTAMP);
END
```

Related concepts

[Triggers \(Introduction to Db2 for z/OS\)](#)

[Naming conventions](#)

The rules for forming a name depend on the type of the object designated by the name.

Related tasks

[Creating a trigger \(Db2 Application programming and SQL\)](#)

CREATE TRUSTED CONTEXT statement

The CREATE TRUSTED CONTEXT statement defines a trusted context at the current server.

Invocation for CREATE TRUSTED CONTEXT

This statement can be embedded in an application program or issued interactively. It is an executable statement that can be dynamically prepared only if DYNAMICRULES run behavior is implicitly or explicitly specified.

Authorization for CREATE TRUSTED CONTEXT

The privilege set that is defined below must include at least one of the following:

- SYSADM authority
- SECADM authority

Privilege set: If the statement is embedded in an application program, the privilege set is the privileges that are held by the owner of the plan or package. If the application is bound in a trusted context with the ROLE AS OBJECT OWNER clause specified, a role is the owner. Otherwise, an authorization ID is the owner.

If the statement is dynamically prepared, the privilege set is the privileges that are held by the SQL authorization ID of the process unless the process is within a trusted context and the ROLE AS OBJECT OWNER clause is specified. In that case, the privileges set is the privileges that are held by the role that is associated with the primary authorization ID of the process.

Syntax for CREATE TRUSTED CONTEXT

► CREATE TRUSTED CONTEXT — *context-name* ►

► BASED UPON CONNECTION USING SYSTEM AUTHID — *authorization-name* ►

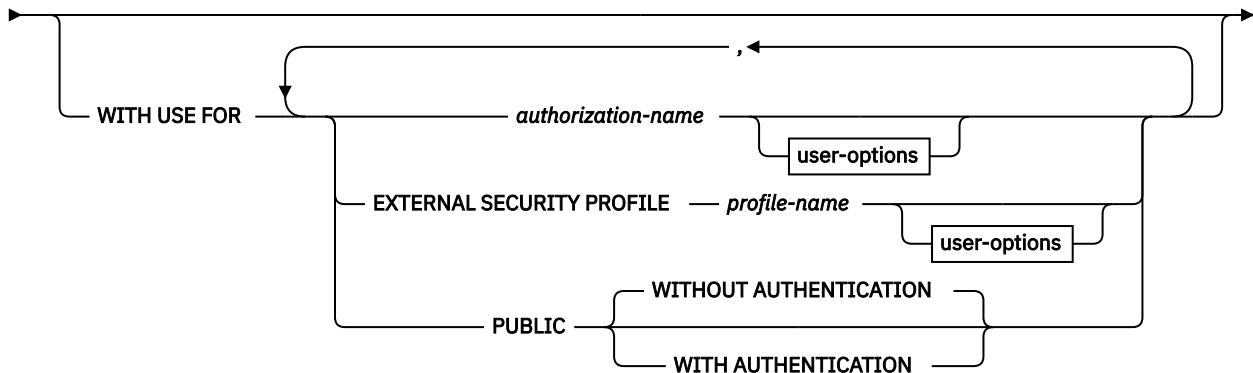
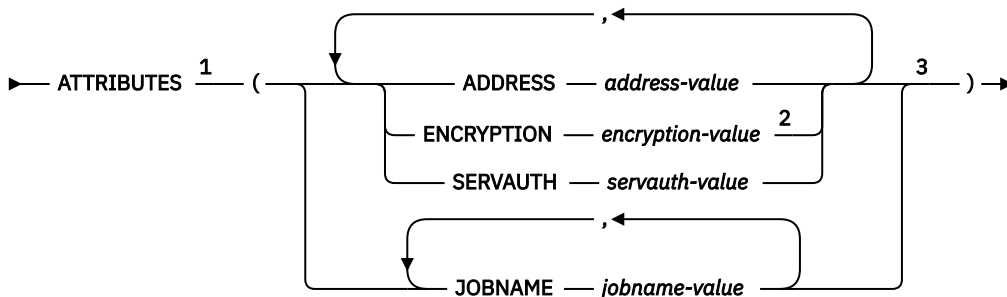
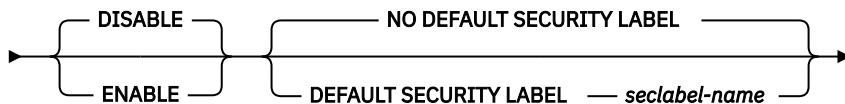
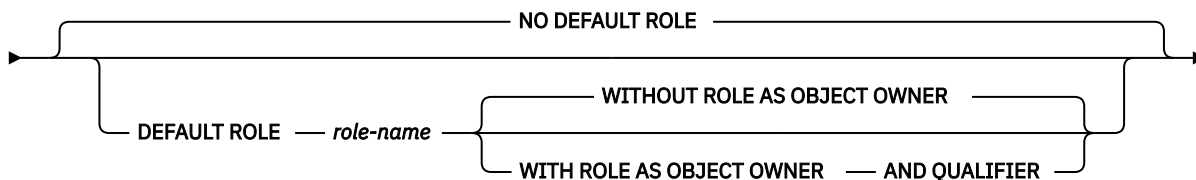

Notes:

- ¹ This clause and the clauses that follow can be specified in any order. Each clause must not be specified more than one time.
- ² ENCRYPTION must not be specified more than one time.
- ³ Each pair of attribute name and corresponding value must be unique.

user-options:

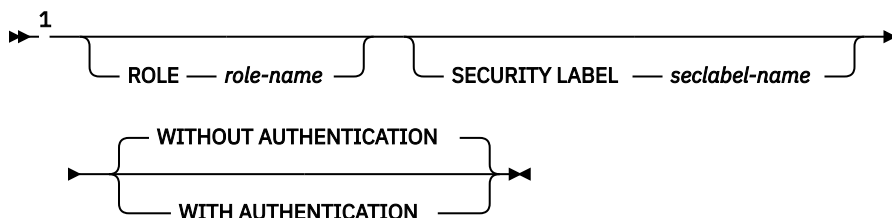

Notes:

¹ These clauses can be specified in any order. Each clause must not be specified more than one time.

Description for CREATE TRUSTED CONTEXT

context-name

Names the trusted context. The name must not identify a trusted context that exists at the current server.

BASED UPON CONNECTION USING SYSTEM AUTHID authorization-name

Specifies that the context is a connection that is established by the authorization ID that is specified by *authorization-name*. The system authorization ID is the primary authorization ID. For a remote connection, it is derived from the system user ID that is provided by an external entity, such as a middleware server. For a local connection, the system authorization ID is derived depending on the sources, as specified in [Table 224 on page 1789](#).

Table 224. System authorization ID for a local connection

Source of local connection	System authorization ID
Started task (RRSAF)	USER parameter on JOB statement or RACF USER.
TSO	TSO logon ID
BATCH	USER parameter on JOB statement

authorization-name must not be associated with an existing trusted context.

NO DEFAULT ROLE or DEFAULT ROLE role-name

Specifies whether a default role is associated with a trusted connection that is based on the specified trusted context.

NO DEFAULT ROLE

Specifies that the trusted context does not have a default role. The authorization ID of the process is the owner of any object that is created using a trusted connection that is based on this trusted context. That authorization ID must possess all of the privileges that are necessary to create that object.

NO DEFAULT ROLE is the default.

DEFAULT ROLE role-name

Specifies that *role-name* is the role for the trusted context. *role-name* must identify a role that exists at the current server. This role is used with the user in a trusted connection that is based on the specified trusted context when the user does not have a user-specified role that is defined as part of the definition of this trusted context.

WITHOUT ROLE AS OBJECT OWNER or WITH ROLE AS OBJECT OWNER AND QUALIFIER

Specifies whether a role is used as the owner of objects that are created using a trusted connection that is based on the specified trusted context.

WITHOUT ROLE AS OBJECT OWNER

Specifies that a role is not used as the owner of the objects that are created using a trusted connection that is based on the specified trusted context. The authorization ID of the process is the owner of any object that is created using a trusted connection that is based on this trusted context. That authorization ID must possess all of the privileges that are necessary to create the object.

WITHOUT ROLE AS OBJECT OWNER is the default.

WITH ROLE AS OBJECT OWNER AND QUALIFIER

Specifies that the context assigned role is the owner of the objects that are created using a trusted connection that is based on this trusted context and that role must possess all of the privileges that are necessary to create the object. The context assigned role is the role that is defined

for the user within this trusted context, if one is defined. Otherwise, the role is the default role that is associated with the trusted context. The role is also used as the grantor for any GRANT statements that are issued, and the revoker for any REVOKE statement that are issued using a trusted connection that is based on this trusted context.

AND QUALIFIER

Specifies that *role-name* will be used as the default for the CURRENT SCHEMA special register. The *role-name* will also be included in the SQL PATH (in place of CURRENT SQLID).

When WITH ROLE AS OBJECT OWNER AND QUALIFIER is not specified, there is no change to the default for the CURRENT SCHEMA special register and the SQL PATH.

DISABLE or ENABLE

Specifies whether the trusted context is created in the enabled or disabled state.

DISABLE

Specified that the trusted context is disabled when it is created. A trusted context that is disabled is not considered when a trusted connection is established. DISABLE is the default.

ENABLE

Specifies that the trusted context is enabled when it is created.

NO DEFAULT SECURITY LABEL or DEFAULT SECURITY LABEL *seclabel-name*

Specifies whether the trusted connection has a default security label.

NO DEFAULT SECURITY LABEL

Specifies that the trusted context does not have a default security label.

DEFAULT SECURITY LABEL *seclabel-name*

Specifies that *seclabel-name* is the default security label for the trusted context and is the security label that is used for multilevel security verification. *seclabel-name* must identify one of the RACF SECLABEL values that is defined for the SYSTEM AUTHID. This security label is used for a trusted connection that is based on the specified trusted context when the user does not have a specific security label defined as part of the definition of this trusted context. In this case, *seclabel-name* must also identify one of the RACF SECLABEL values that is defined for the user.

ATTRIBUTES

Specifies a list of one or more connection trust attributes that are used to define the trusted context.

ADDRESS *address-value*

Specifies the actual communication address that is used by the connection to communicate with the database manager. The protocol supported is only for TCP/IP. The ADDRESS attribute can be specified multiple times, but each *address-value* must be unique.

When establishing a trusted connection, if multiple values are defined for the ADDRESS attribute for a trusted context, a candidate connection is considered to match this attribute if the address that is used by a connection matches any of the defined values for the ADDRESS attribute of the trusted context.

address-value specifies a string constant that contains the value that is associated with the ADDRESS trust attribute. *address-value* must be an IPv4 address, an IPv6 address, or a secure domain name with a length no greater than 254 bytes. No validation of *address-value* is done at the time the CREATE TRUSTED CONTEXT statement is processed. *address-value* must be left justified within the string constant.

- An IPv4 address is represented as a dotted decimal address. An example of an IPv4 address is 9.112.46.111
- An IPv6 address is represented as a colon hexadecimal address. An example of an IPv6 address is 2001:0DB8:0000:0000:0008:0800:200C:417A. This address can also be express in a compressed form as 2001:DB8::8:800:200C:417A.
- A domain name is converted to an IP address by the domain name server where a resulting IPv4 or IPv6 address is determined. An example of a domain name is www.ibm.com. The gethostbyname socket call is used to resolve the domain name.

ENCRYPTION *encryption-value*

Specifies the minimum level of encryption of the data stream (network encryption).

encryption-value specifies a string constant that contains the value that is associated with the ENCRYPTION trust attribute. *encryption-value* must be left justified within the string constant. ENCRYPTION must not be specified more than one time in the statement. *encryption-value* must be one of the following:

- NONE, which specifies that no specific level of encryption is required.
- LOW, which specifies that a minimum of light encryption is required. LOW corresponds to 64-bit DRDA encryption.
- HIGH, which specifies that strong encryption is required. HIGH corresponds to SSL encryption.

The following table summarizes when a trusted context can be used depending on the encryption that is used by the existing connection. If the trusted context cannot be used for the connection, a warning is returned.

Table 225. Summary of when trusted context can be used by an existing connection

Encryption that is used by the existing connection	Value of the ENCRYPTION clause for the trusted context	Can the trusted context be used for the connection?
No encryption	NONE	Yes
No encryption	LOW	No
No encryption	HIGH	No
Low encryption (64-bit)	NONE	Yes
Low encryption (64-bit)	LOW	Yes
Low encryption (64-bit)	HIGH	No
High encryption (128-bit)	NONE	Yes
High encryption (128-bit)	LOW	Yes
High encryption (128-bit)	HIGH	Yes

JOBNAME *jobname-value*

Specifies the z/OS job name or started task name (depending on the source of the address space) for local applications. The JOBNAME attribute can be specified multiple times, but each *jobname-value* must be unique.

jobname-value specifies a string constant that contains the value that is associated with the JOBNAME trust attribute. *jobname-value* is an EBCDIC 8 byte value that specifies the job name or the started task name. The value must be left justified within the string constant. The last character in the name can be a wildcard character (*) if the first character is an alphabetic character. If the job name ends with a wildcard, any job names that begin with the specified characters are considered for establishing the trusted connection.

The following table lists possible values for the job name depending on the source of the address space.

Table 226. Job name for local connection

Source of the address space	Job name
RRSAF	Job name or started task name
TSO	TSO logon ID
BATCH	Job name on JOB statement

SERVAUTH *servauth-value*

Specifies the name of a resource in the RACF SERVAUTH class. This resource is the network access security zone name that contains the IP address of the connection that is used to communicate with Db2. The SERVAUTH attribute can be specified multiple times but each *servauth-value* must be unique.

servauth-value specifies a string constant that contains the value that is associated with the SERVAUTH trust attribute. *servauth-value* is an EBCDIC 64 byte RACF SERVAUTH CLASS resource name. *servauth-value* must be left justified in the string constant. No validation of *servauth-value* is done at the time the CREATE TRUSTED CONTEXT statement is processed.

WITH USE FOR

Specifies who can use a trusted connection that is based on the specified trusted context.

authorization-name

Specifies that the trusted connection can be used by the specified *authorization-name*. This is the Db2 primary authorization ID. The *authorization-name* must not be specified more than one time in the WITH USE FOR clause.

ROLE *role-name*

Specifies that *role-name* is the role that is used when a trusted connection is used by the specified *authorization-name*. The *role-name* must identify a role that exists at the current server. The role that is explicitly specified for the user overrides any default role that is associated with the trusted context.

SECURITY LABEL *seclabel-name*

Specifies that *seclabel-name* is the security label to use for multilevel security verification when the trusted connection is used by the specified *authorization-name*. The *seclabel-name* must be one of the RACF SECLABEL values that is defined for the user. The security label that is explicitly specified for the user overrides any default security label that is associated with the trusted context.

WITHOUT AUTHENTICATION or WITH AUTHENTICATION

Specifies whether use of the trusted connection requires authentication of the user.

WITHOUT AUTHENTICATION

Specifies that use of a trusted connection by the user does not require authentication. WITHOUT AUTHENTICATION is the default.

WITH AUTHENTICATION

Specifies that use of a trusted connection requires the authentication token with the authorization ID to authenticate the user. If a trusted connection is established locally, the authentication token is the password that is provided by the CONNECT statement with the USER and USING clauses. If the trusted connection is established from a remote client, the authentication token can be one of the following tokens:

- password
- RACF Passticket
- Kerberos token

EXTERNAL SECURITY PROFILE *profile-name*

Specifies that the trusted connection can be used by the Db2 primary authorization IDs that are permitted to use the specified *profile-name* in RACF. *profile-name* must not be specified more than one time in the WITH USE FOR clause. If an authorization ID is permitted to use more than one specified *profile-name*, the role that is specified for *profile-name* can be associated with the process if the user authentication satisfies the AUTHENTICATION definition. This role can hold additional privileges that are available to the process.

ROLE *role-name*

Specifies that *role-name* is the role that is used when a trusted connection is used by any authorization ID permitted to use the specified *profile-name* in RACF. The *role-name* must identify a role that exists at the current server. The role that is explicitly specified for the profile overrides any default role that is associated with the trusted context.

SECURITY LABEL *seclabel-name*

Specifies that *seclabel-name* is the security label to use for multilevel security verification when the trusted connection is used by any authorization ID that is permitted to use the specified *profile-name* in RACF. The *seclabel-name* must be one of the RACF SECLABEL values that is defined for the user. The security label that is explicitly specified for the profile overrides any default security label that is associated with the trusted context.

WITHOUT AUTHENTICATION or WITH AUTHENTICATION

Specifies whether use of the trusted connection requires authentication of the user.

WITHOUT AUTHENTICATION

Specifies that use of a trusted connection by the user does not require authentication. WITHOUT AUTHENTICATION is the default.

WITH AUTHENTICATION

Specifies that use of a trusted connection requires the authentication token with the authorization ID to authenticate the user. If a trusted connection is established locally, the authentication token is the password that is provided by the CONNECT statement with the USER and USING clauses. If the trusted connection is established from a remote client, the authentication token can be one of the following tokens:

- password
- RACF Passticket
- Kerberos token

PUBLIC

Specifies that a trusted connection that is based on the specified trusted context can be used by any user. All users that are using a trusted connection that is defined with PUBLIC use the privileges that are associated with the default role for the associated trusted context. If the default role is not defined for the trusted context, there is no role associated with the users that use a trusted connection that is based on the specified trusted context.

If the default security label for the trusted context is defined, all users that are using the trusted context must have the security label defined as one of the RACF SECLABEL values for the user. The default security label is used for multilevel security verification with all users that are using the trusted context.

WITHOUT AUTHENTICATION or WITH AUTHENTICATION

Specifies whether use of the trusted connection requires authentication of the user.

WITHOUT AUTHENTICATION

Specifies that use of a trusted connection by the user does not require authentication. WITHOUT AUTHENTICATION is the default.

WITH AUTHENTICATION

Specifies that use of a trusted connection requires the authentication token with the authorization ID to authenticate the user. If a trusted connection is established locally, the authentication token is the password that is provided by the CONNECT statement with the USER and USING clauses. If the trusted connection is established from a remote client, the authentication token can be one of the following tokens:

- password
- RACF Passticket
- Kerberos token

Notes for CREATE TRUSTED CONTEXT

Owner privileges: There are no specific privileges on a trusted context.

Requirement for trusted connections: If you set field 1 (RESTART or DEFER) to DEFER and set field 2 (objects to restart or defer) to ALL in installation panel DSNTIPS, you cannot use trusted connections.

Order of precedence for users of a trusted connection: The specifications for a user are determined in the following order of precedence:

- *authorization-name*
- EXTERNAL SECURITY PROFILE *profile-name*
- PUBLIC

For example, assume that a trusted context is defined with use for JOE WITH AUTHENTICATION, EXTERNAL SECURITY PROFILE SPROFILE WITHOUT AUTHENTICATION, and PUBLIC WITH AUTHENTICATION. Users JOE and SAM are permitted to use the RACF PROFILE SPROFILE. If the trusted connection is used by JOE, authentication is required. If the trusted connection is used by SAM, authentication is not required. However, if user SALLY uses the trusted connection, authentication is required.

User-clause SYSTEM AUTHID considerations: If the *authorization-name* that is specified in the SYSTEM AUTHID clause is the same as the *authorization-name* that is specified in the user-clause *authorization-name*, the role or the security label that is specified for *authorization-name* takes precedence over the default value. The value that is specified for the *profile-name*, is permitted to use the profile. If the authorization name that is specified in the SYSTEM AUTHID clause is permitted to use one of the profile names and is not defined in *authorization-name*, the role or the security label that is specified for that *profile-name* takes precedence over the default value.

If authentication is required for SYSTEM AUTHID, either by specification of the AUTHENTICATION clause in the *user-clause* or by setting the value of the TCP/IP Already Verified subsystem parameter to NO, the authentication requirement takes precedence when establishing a remote trusted connection. For example, if *authorization-name* is the same as the authorization name that is specified for SYSTEM AUTHID and the WITHOUT AUTHENTICATION clause is specified, but the TCP/IP Already Verified subsystem parameter is set to NO, an authentication token is required for SYSTEM AUTHID when the remote trusted connection is established. If *authorization-name* is the SYSTEM AUTHID and the WITH AUTHENTICATION clause is specified, but the TCP/IP Already Verified subsystem parameter is set to YES, an authentication token is still required for SYSTEM AUTHID.

Specifying a role in the definition of a trusted context: The definition of a trusted context can designate a role for a specific authorization ID, and a default role for use for an authorization ID for which a specific role has not been specified in the definition of the trusted context. This role can be used with a trusted connection that is based on the trusted context, but it does not make the role available outside of a trusted connection that is based on the trusted context. When an SQL statement that is not a CREATE, GRANT, or REVOKE statement is issued using a trusted connection, the privileges that are held by a role that is in effect for the authorization ID within the definition of the associated trusted context are considered in addition to other privileges that are directly held by the authorization ID of the statement. The CREATE, GRANT, and REVOKE statements only consider the privileges of the role that is in effect for the trusted connection, or the authorization ID of the statement if a role is not in effect for the trusted connection. If ROLE AS OBJECT OWNER is in effect for a trusted connection, the role that is in effect for the authorization ID for the trusted connection becomes the owner of any object that is created while using the trusted connection.

When a newly created trusted context takes effect: The newly created trusted context takes effect after the CREATE TRUSTED CONTEXT statement is committed. If the CREATE TRUSTED CONTEXT statement results in an error or is rolled back, no trusted context is created.

Examples for CREATE TRUSTED CONTEXT

Example 1: The following statement creates a trusted context called CTX1, which is based on a connection and can only be used by users JOE and SAM. Authentication information is required for JOE to use the trusted connection. The trusted context specifies a default role called CTXROLE. However, when

JOE uses the trusted connection, the default role is overridden by the user role, ROLE1. When SAM uses the trusted connection, SAM uses the default role. CTX1 is enabled when it is created.

```
CREATE TRUSTED CONTEXT CTX1
  BASED UPON CONNECTION USING SYSTEM AUTHID ADMF001
  ATTRIBUTES (ADDRESS '9.30.131.203' ,
             ENCRYPTION 'LOW')
  DEFAULT ROLE CTXROLE
  ENABLE
  WITH USE FOR SAM, JOE ROLE ROLE1 WITH AUTHENTICATION;
```

Example 2: The following statement creates a trusted context, CTX2, for a started task, WASPROD. CTX2 is based on a connection, can be used by user SALLY, specifies a default role CTXROLE, and is enabled when it is created. SALLY uses the default role that is associated with the trusted context.

```
CREATE TRUSTED CONTEXT CTX2
  BASED UPON CONNECTION USING SYSTEM AUTHID ADMF002
  ATTRIBUTES (JOBNAME 'WASPROD')
  DEFAULT ROLE CTXROLE WITH ROLE AS OBJECT OWNER AND QUALIFIER
  ENABLE
  WITH USE FOR SALLY;
```

CREATE TYPE statement

The CREATE TYPE statement defines a user-defined data type at the current server.

The following types of user-defined data types can be defined:

Array

A user-defined data type that is an ordinary array or an associative array. The elements of an array type are based on one of the built-in data types. See [“CREATE TYPE statement \(array type\)” on page 1795](#).

Distinct

A user-defined data type that shares a common representation with one of the built-in data types. Functions that cast between the user-defined distinct type and the source built-in data type are generated when the user-defined distinct type is created. Optionally, support for comparison operations to use with the user-defined distinct type can be generated when the user-defined distinct type is created. See [“CREATE TYPE statement \(distinct type\)” on page 1801](#).

Related concepts

[Distinct types \(Db2 Application programming and SQL\)](#)

[Arrays in SQL statements \(Db2 Application programming and SQL\)](#)

CREATE TYPE statement (array type)

The CREATE TYPE (array) statement defines an array type at the current server. An array type is a user-defined data type that is an ordinary array or an associative array. The elements of an array type are based on one of the built-in data types.

Invocation for CREATE TYPE (array)

This statement can be embedded in an application program or issued through the use of dynamic SQL statements. It is an executable statement that can be dynamically prepared only if DYNAMICRULES RUN behavior is in effect. For more information, see [“Authorization IDs and dynamic SQL” on page 94](#).

Authorization for CREATE TYPE (array)

The privilege set that is defined below must include at least one of the following:

- The CREATEIN privilege on the schema
- SYSADM or SYSCTRL authority
- System DBADM

- Installation SYSOPR authority (when the current SQLID of the process is set to SYSINSTL)

The authorization ID that matches the schema name implicitly has the CREATEIN privilege on the schema.

Privilege set: If the statement is embedded in an application program, the privilege set is the privileges that are held by the owner of the plan or package.

If the statement is running under a trusted context for which the ROLE AS OBJECT OWNER clause is specified, the owner is a role. The implicit schema match does not apply, and this role needs to include one of the previously listed conditions.

If the statement is dynamically prepared and is not running in a trusted context for which the ROLE AS OBJECT OWNER clause is specified, the privilege set is the set of privileges that are held by the SQL authorization ID of the process. The specified distinct type name can include a schema name (a qualifier). If the schema name is not the same as the SQL authorization ID of the process, one of the following conditions must be met:

- The privilege set includes SYSADM or SYSCTRL authority.
- The SQL authorization ID of the process has the CREATEIN privilege on the schema.

Syntax for CREATE TYPE (array)

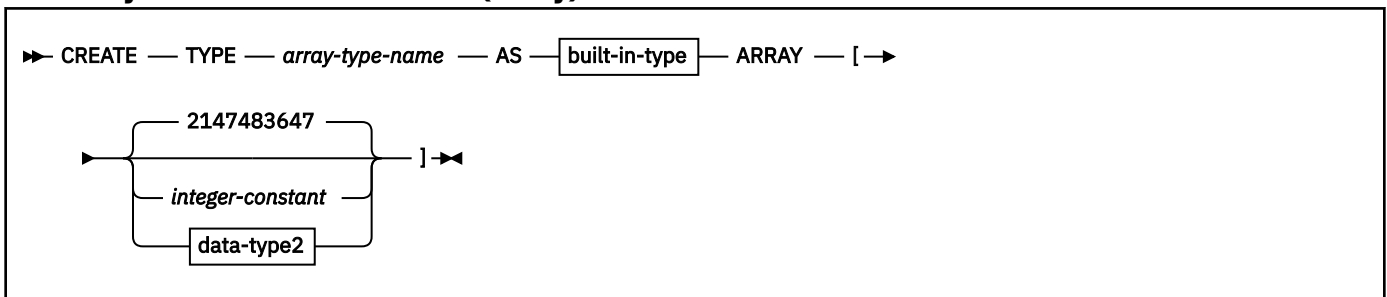

built-in-type:

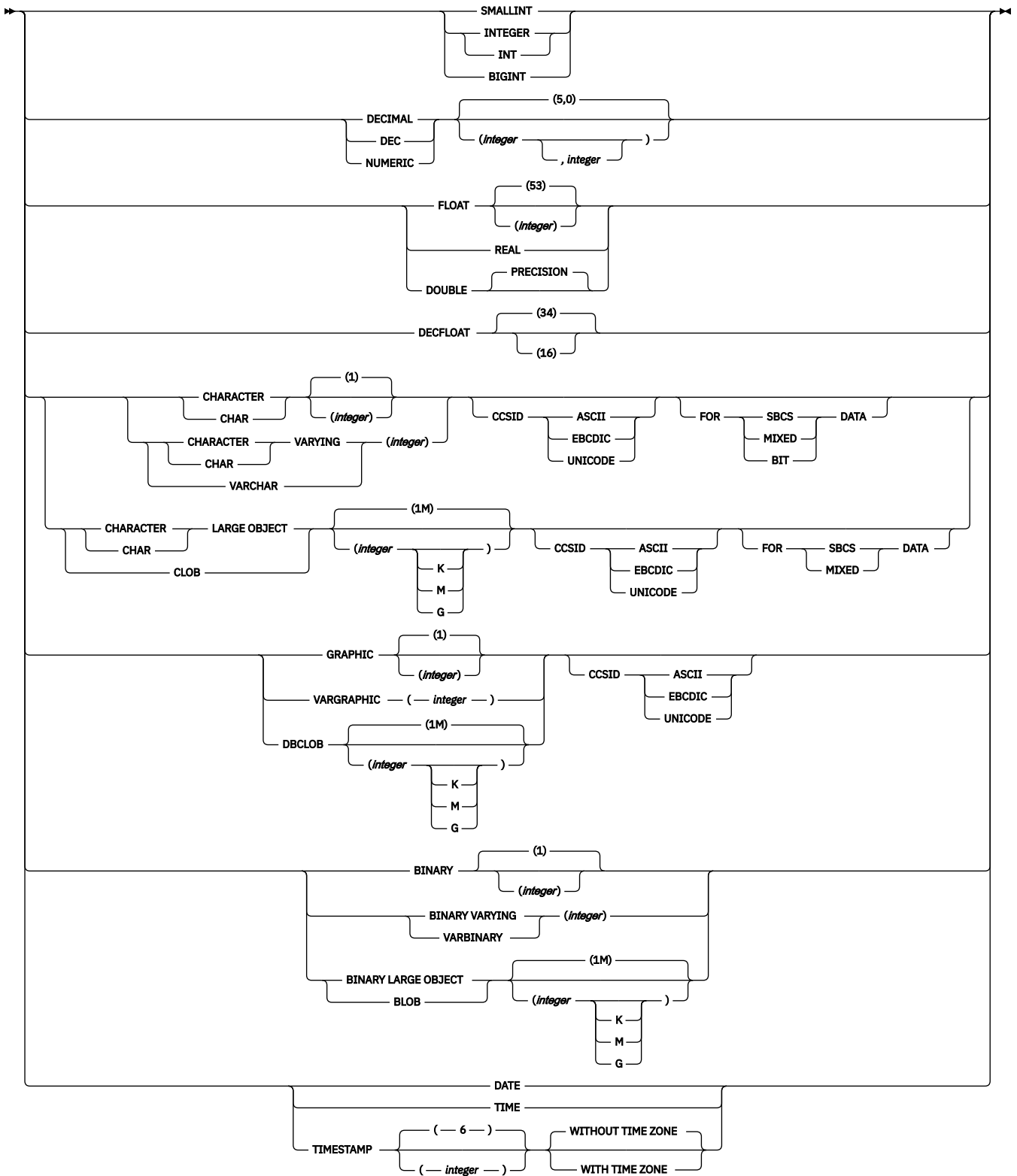

data-type2:

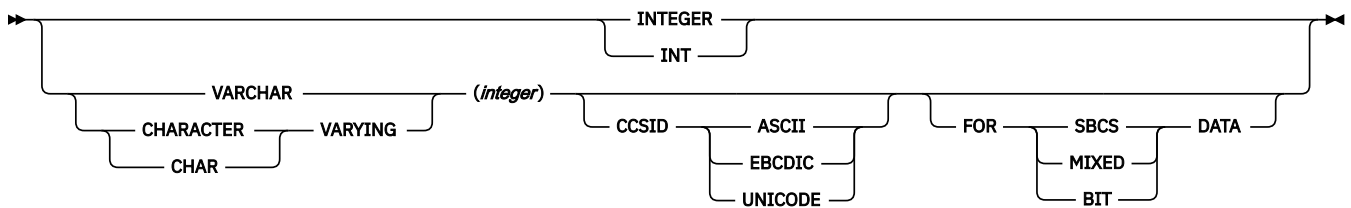

Description for CREATE TYPE (array)

array-type-name

Names the array type. The name, including the implicit or explicit qualifier, must not identify any other built-in or user-defined type that exists at the current server.

The unqualified form of *array-type-name* must not be any of the following system-reserved keywords, even if you specify them as delimited identifiers:

ALL	LIKE	UNIQUE
AND	MATCH	UNKNOWN
ANY	NOT	=
BETWEEN	NULL	<
DISTINCT	ONLY	<=
EXCEPT	OR	<
EXISTS	OVERLAPS	>
FALSE	SIMILAR	>=
FOR	SOME	>
FROM	TABLE	<>
IN	TRUE	
IS	TYPE	

The schema name can be 'SYSTOOLS' if the privilege set includes the SYSADM or SYSCTRL privilege. Otherwise, the schema name must not begin with 'SYS' unless the schema name is 'SYSADM'.

built-in-type

Specifies the built-in data type of the array elements. The data type must not be ROWID or XML. For more information on built-in data types, see [built-in-type in CREATE TABLE](#).

CCSID ASCII, EBCDIC, or UNICODE in a *built-in-type* specification

If the data type is a character or graphic string and a CCSID clause is not specified for *built-in-type*, the default CCSID for *built-in-type* is determined as follows:

- If *data-type2* is a character string data type with an explicit CCSID clause, that same CCSID value is used for *built-in-type*.
- If *data-type2* is a character string data type without an explicit CCSID clause, the CCSID for *built-in-type* is determined from the encoding scheme that is indicated by the value of field DEF ENCODING SCHEME on installation panel DSNTIPF.

If a CCSID clause is specified for *built-in-type* and for *data-type2*, the CCSID values must be the same.

FOR SBCS, MIXED, or BIT DATA in a *built-in-type* specification

Specifies a subtype for a character string data type (VARCHAR). Do not use this clause with any other data type.

SBCS

Single-byte data.

MIXED

Mixed data. Do not specify MIXED if the value of field MIXED DATA on installation panel DSNTIPF is NO unless the CCSID UNICODE clause is also specified.

BIT

Bit data.

If you do not specify the FOR SBCS DATA, FOR MIXED DATA, or FOR BIT DATA clause, the default value is determined as follows:

- For ASCII or EBCDIC data:

- The default is SBCS when the value of field MIXED DATA on installation panel DSNTIPF is NO.
- The default is MIXED when the value is YES.
- For Unicode data, the default subtype is MIXED.

ARRAY[integer-constant]

Specifies that the type is an ordinary array with a maximum cardinality of *integer-constant*. The value must be an integer that is greater than 0 and less than or equal to the largest positive integer value (2147483647). The default is 2147483647. Each varying-length string array element is allocated as its maximum length.

The cardinality of an array value is determined by the highest element position that is assigned to the array value. The maximum cardinality of an array is limited by the total amount of memory that is available to Db2 applications. Therefore, although an array with a large cardinality can be created, not all elements might be available for use. An attempt to assign a value to an array element when there is not enough memory results in an error.

ARRAY[data-type2]

Specifies that the type is an associative array that is indexed by values of data type *data-type2*. The data type must be the INTEGER or VARCHAR data type. The value that is specified as the index during assignment of a value to an array element must be assignable to a value of *data-type2*.

The cardinality of an array value is determined by the number of unique index values that are used when during assignment of array elements.

CCSID ASCII, EBCDIC, or UNICODE in a data-type2 specification

If the data type is a character string, and a CCSID clause is not specified for *data-type2*, the default CCSID is determined as follows:

- If *built-in-type* is a character string data type with an explicit CCSID clause, that same CCSID value is used for *data-type2*.
- If *built-in-type* is a character string data type without an explicit CCSID clause, the CCSID for *data-type2* is determined from the encoding scheme that is indicated by the value of field DEF ENCODING SCHEME on installation panel DSNTIPF.

If a CCSID clause is specified for *built-in-type* and for *data-type2*, the CCSID values must be the same.

FOR SBCS, MIXED, or BIT DATA in a data-type2 specification

Specifies a subtype for a character string data type (VARCHAR). Do not use this clause with any other data type.

SBCS

Single-byte data.

MIXED

Mixed data. Do not specify MIXED if the value of field MIXED DATA on installation panel DSNTIPF is NO unless the CCSID UNICODE clause is also specified.

BIT

Bit data.

If you do not specify the FOR SBCS DATA, FOR MIXED DATA, or FOR BIT DATA clause, the default value is determined as follows:

- For ASCII or EBCDIC data:
 - The default is SBCS when the value of field MIXED DATA on installation panel DSNTIPF is NO.
 - The default is MIXED when the value is YES.
- For Unicode data, the default subtype is MIXED.

Notes for CREATE TYPE (array)

Array type usage: A user-defined array type can only be used as the data type of:

- An SQL variable

- A global variable
- A parameter or RETURNS *data-type* of an SQL scalar function
- A parameter of a native SQL procedure
- The target data type for a CAST specification

Generated cast functions: The successful execution of the CREATE TYPE (array) statement causes the Db2 database manager to generate cast functions for the user-defined array type. Those cast functions are recorded in the Db2 catalog. The unqualified names of the two cast functions are ARRAY and the name of the array type. A generated cast function cannot be explicitly dropped. The cast functions that are generated for an array type are implicitly dropped when the array type is dropped with the DROP statement.

Examples for CREATE TYPE (array)

Example 1

Create an ordinary array user-defined type named PHONENUMBERS, with a maximum of 50 elements. The elements are of the DECIMAL(10,0) data type.

```
CREATE TYPE PHONENUMBERS AS DECIMAL(10,0) ARRAY[50];
```

Example 2

Create an ordinary array user-defined type named NUMBERS, in the schema GENERIC. You do not know the maximum number of elements, so you use the default value. The elements are of the DECFLOAT(34) data type.

```
CREATE TYPE GENERIC.NUMBERS AS DECFLOAT(34) ARRAY[];
```

Example 3

Create an associative array user-defined type named PERSONAL_PHONENUMBERS. The elements are of the DECIMAL(16, 0) data type. The array type is indexed by strings such as 'Home', 'Work', or 'Cell', so the index data type must be VARCHAR.

```
CREATE TYPE PERSONAL_PHONENUMBERS AS DECIMAL(16,0) ARRAY[VARCHAR(8)];
```

Example 4

Create an associative array user-defined type named CAPITALSARRAY. The elements are capital cities. The index values are province, territory, or country names, so the index data type must be VARCHAR.

```
CREATE TYPE CAPITALSARRAY AS VARCHAR(30) ARRAY[VARCHAR(20)];
```

Example 5

Create an associative array user-defined type named PRODUCTS. The elements are product descriptions of up to 40 characters. The index values are product numbers, which have the INTEGER data type.

```
CREATE TYPE PRODUCTS AS VARCHAR(40) ARRAY[INTEGER];
```

Related concepts

[Arrays in SQL statements \(Db2 Application programming and SQL\)](#)

[Example of using arrays in an SQL procedure \(Db2 Application programming and SQL\)](#)

[Naming conventions](#)

The rules for forming a name depend on the type of the object designated by the name.

CREATE TYPE statement (distinct type)

The CREATE TYPE (distinct) statement defines a distinct type, which is a data type that a user defines. A distinct type must be based on one of the built-in data types.

Successful execution of the statement also generates:

- A function to cast between the distinct type and its source type
- A function to cast between the source type and its distinct type
- As appropriate, support for the use of comparison operators with the distinct type

Invocation for CREATE TYPE (distinct)

This statement can be embedded in an application program or issued interactively. It is an executable statement that can be dynamically prepared only if DYNAMICRULES RUN behavior is in effect. For more information, see [“Authorization IDs and dynamic SQL” on page 94](#).

Authorization for CREATE TYPE (distinct)

The privilege set that is defined below must include at least one of the following:

- The CREATEIN privilege on the schema
- SYSADM or SYSCTRL authority
- System DBADM
- Installation SYSOPR authority (when the current SQLID of the process is set to SYSINSTL)

The authorization ID that matches the schema name implicitly has the CREATEIN privilege on the schema.

Privilege set: If the statement is embedded in an application program, the privilege set is the privileges that are held by the owner of the plan or package. If the owner is a role, the implicit schema match does not apply and this role needs to include one of the previously listed conditions.

If the statement is dynamically prepared and is not running in a trusted context for which the ROLE AS OBJECT OWNER clause is specified, the privilege set is the set of privileges that are held by the SQL authorization ID of the process. The specified distinct type name can include a schema name (a qualifier). If the schema name is not the same as the SQL authorization ID of the process, one of the following conditions must be met:

- The privilege set includes SYSADM or SYSCTRL authority.
- The SQL authorization ID of the process has the CREATEIN privilege on the schema.

Syntax for CREATE TYPE (distinct)

```
►► CREATE — TYPE — distinct-type-name — AS — source-data-type ►►  
  
┌──────────────────────────────────────────────────────────────────────────────────┐  
│ INLINE LENGTH — integer 1 ───────────────────────────────────────────────────┘
```

Notes:

¹ INLINE LENGTH can only be specified when *source-data-type* is a LOB data type.

source-data-type

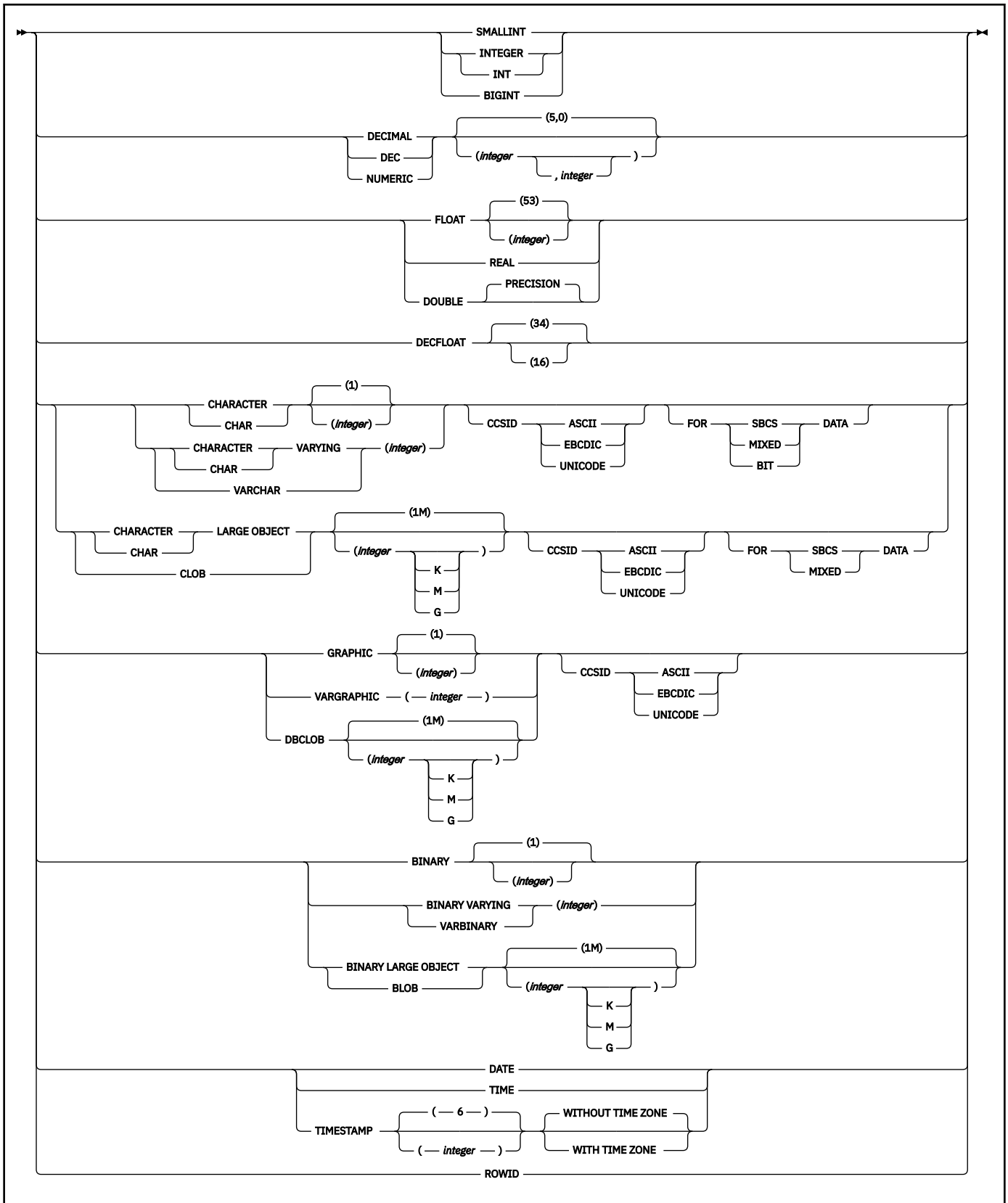

Description for CREATE TYPE (distinct)

distinct-type-name

Names the distinct type. The name, including the implicit or explicit qualifier, must not identify a distinct type that exists at the current server.

- The unqualified form of *distinct-type-name* must not be the name of a built-in data type, BOOLEAN, or any of following system-reserved keywords even if you specify them as delimited identifiers:

ALL	LIKE	UNIQUE
AND	MATCH	UNKNOWN
ANY	NOT	=
BETWEEN	NULL	≠
DISTINCT	ONLY	<
EXCEPT	OR	<=
EXISTS	OVERLAPS	<<
FALSE	SIMILAR	>
FOR	SOME	>=
FROM	TABLE	→
IN	TRUE	<>
IS	TYPE	

- The qualified form of *distinct-type-name* is an SQL identifier (the schema name) followed by a period and an SQL identifier.

The schema name can be 'SYSTOOLS' if the privilege set includes the SYSADM or SYSCTRL privilege. Otherwise, the schema name must not begin with 'SYS' unless the schema name is 'SYSADM'.

source-data-type

Specifies the data type that is used as the basis for the internal representation of the distinct type. The data type must be a built-in data type. For more information on built-in data types, see [built-in-type](#).

If the distinct type is based on a character or graphic string data type, the FOR clause indicates the subtype. If you do not specify the FOR clause, the distinct type is defined with the default subtype. For ASCII or EBCDIC data, the default is SBCS when the value of field MIXED DATA on installation panel DSNTIPF is NO. The default is MIXED when the value is YES. For UNICODE character data, the default subtype is mixed.

If the distinct type is based on a string data type, the CCSID clause indicates whether the encoding scheme of the data is ASCII, EBCDIC or UNICODE. If you do not specify CCSID ASCII, CCSID EBCDIC, or UNICODE, the encoding scheme is the value of field DEF ENCODING SCHEME on installation panel DSNTIPF.

INLINE LENGTH integer

Specifies the default inline length for columns that reference the distinct type. INLINE LENGTH can only be specified when *source-data-type* is a LOB data type. Only columns in a table that is in a universal table space can inherit the specified inline length for the distinct type. If the table is not in a universal table space, the specified inline length is ignored.

Where *source-data-type* is BLOB and CLOB, *integer* specifies the maximum number of bytes that are stored in the base table space for columns that reference this distinct type. *integer* must be in the range 0–32680 (inclusive) for a BLOB or CLOB *source-data-type*.

Where *source-data-type* is DBCLOB, *integer* specifies the maximum number of double-byte characters that are stored in the table space for columns that reference the distinct type. *integer* must be in the range 0–16340 (inclusive) for a DBCLOB *source-data-type*.

If INLINE LENGTH is specified with a value of 0 for *integer*, any column that references the distinct type will not have an inline length unless the CREATE TABLE or ALTER TABLE ADD statement specifies an inline length for the column.

If INLINE LENGTH is not specified, any column that reference the distinct type takes its default value from the value of the LOB INLINE LENGTH parameter on installation panel DSNTIPD.

integer cannot be greater than the maximum length of the distinct type.

Notes for CREATE TYPE (distinct)

Owner privileges:

The owner of the distinct type is authorized to define columns, parameters, or variables with the distinct type (USAGE privilege) with the ability to grant these privileges to others. See [GRANT](#)

statement (type or JAR file privileges)” on page 1991. The owner is also authorized to invoke the generated cast function (EXECUTE privilege; see “GRANT statement (function or procedure privileges)” on page 1970). The owner is given the USAGE and EXECUTE privileges with the GRANT option. For more information about ownership of the object, see “Authorization, privileges, permissions, masks, and object ownership” on page 90.

Base data types with DBCS or mixed data:

When the implicit or explicit encoding scheme is ASCII or EBCDIC and the base data type is graphic or a character type is MIXED DATA, then the value of field FOR MIXED DATA on installation panel DSNTIPF must be YES; otherwise, an error occurs.

Generated cast functions:

The successful execution of the CREATE TYPE (distinct) statement causes Db2 to generate the following cast functions:

- A function to convert from the distinct type to its base data type
- A function to convert from the base data type to the distinct type
- A function to cast from a data type *A* to distinct type *DT*, where *A* is promotable to the base data type *S* of distinct type *DT*

For some base data types, Db2 supports an additional function to convert from:

- INTEGER to the distinct type if the source type is SMALLINT
- VARCHAR to the distinct type if the source type is CHAR
- VARGRAPHIC to the distinct type if the source type is GRAPHIC
- VARBINARY to the distinct type if the source type is BINARY
- DOUBLE to the distinct type if the source type is REAL

The cast functions are created as if the following statements were executed:

```
CREATE FUNCTION source-type-name (distinct-type-name)
  RETURNS source-type-name ...
CREATE FUNCTION distinct-type-name (source-type-name)
  RETURNS distinct-type-name ...
```

In cases in which a length, precision, or scale is specified for the base type in the CREATE TYPE statement, the unqualified name of the cast function that converts from the distinct type to the base type is the name of the base data type. The data type of the value that the cast function returns includes any length, precision, or scale values that were specified for the base data type on the CREATE TYPE statement. (See [Table 227 on page 1805](#) for details.)

For example, assume that a distinct type named T_SHOESIZE is created with the following statement:

```
CREATE TYPE CLAIRES.T_SHOESIZE AS VARCHAR(2)
```

When the statement is executed, Db2 also generates the following cast functions. VARCHAR converts from the distinct type to the source type, and T_SHOESIZE converts from the source type to the distinct type.

```
FUNCTION CLAIRES.VARCHAR (CLAIRES.T_SHOESIZE) RETURNS SYSIBM.VARCHAR (2)
FUNCTION CLAIRES.T_SHOESIZE (SYSIBM.VARCHAR (2)) RETURNS CLAIRES.T_SHOESIZE
```

Notice that function VARCHAR returns a value with a data type of VARCHAR(2) and that function T_SHOESIZE has an input parameter with a data type of VARCHAR(2).

The schema of the generated cast functions is the same as the schema of the distinct type. No other function with the same name and function signature must already exist in the database.

In the preceding example, if T_SHOESIZE was based on a SMALLINT, CHAR, or GRAPHIC data type instead of a VARCHAR data type, another cast function would have been generated in addition to the two functions to cast between the distinct type and the base data type. For example, assume that T_SHOESIZE is created with this statement:

```
CREATE TYPE CLAIRE.T_SHOESIZE AS CHAR(2)
```

When the statement is executed, Db2 generates these cast functions:

```
FUNCTION CLAIRE.CHAR (CLAIRE.T_SHOESIZE) RETURNS SYSIBM.CHAR (2)
FUNCTION CLAIRE.T_SHOESIZE (SYSIBM.CHAR (2)) RETURNS CLAIRE.T_SHOESIZE
FUNCTION CLAIRE.T_SHOESIZE (SYSIBM.VARCHAR (2)) RETURNS CLAIRE.T_SHOESIZE
```

Notice that the third function enables the casting of a VARCHAR(2) to T_SHOESIZE. This additional function is created to enable casting a constant, such as 'AB', directly to the distinct type. Without the additional function, you would have to first cast 'AB', which has a data type of VARCHAR, to a data type of CHAR and then cast it to the distinct type.

You cannot explicitly drop a generated cast function. The cast functions that are generated for a distinct type are implicitly dropped when the distinct type is dropped with the DROP statement.

For each built-in data type that can be the base data type for a distinct type, the following table gives the names of the generated cast functions, the data types of the input parameters, and the data types of the values that the functions returns.

Table 227. CAST functions on distinct types

Source type name	Function name	Parameter-type	Return-type
SMALLINT	<i>distinct-type-name</i>	SMALLINT	<i>distinct-type-name</i>
	<i>distinct-type-name</i>	INTEGER	<i>distinct-type-name</i>
	SMALLINT	<i>distinct-type-name</i>	SMALLINT
INTEGER	<i>distinct-type-name</i>	INTEGER	<i>distinct-type-name</i>
	INTEGER	<i>distinct-type-name</i>	INTEGER
BIGINT	<i>distinct-type-name</i>	BIGINT	<i>distinct-type-name</i>
	BIGINT	<i>distinct-type-name</i>	BIGINT
DECIMAL	<i>distinct-type-name</i>	DECIMAL (p,s)	<i>distinct-type-name</i>
	DECIMAL	<i>distinct-type-name</i>	DECIMAL (p,s)
NUMERIC	<i>distinct-type-name</i>	DECIMAL (p,s)	<i>distinct-type-name</i>
	DECIMAL	<i>distinct-type-name</i>	DECIMAL (p,s)
REAL	<i>distinct-type-name</i>	REAL	<i>distinct-type-name</i>
	<i>distinct-type-name</i>	DOUBLE	<i>distinct-type-name</i>
	REAL	<i>distinct-type-name</i>	REAL
DECFLOAT	<i>distinct-type-name</i>	DECFLOAT(n)	DECFLOAT(n)
	DECFLOAT	<i>distinct-type-name</i>	DECFLOAT(n)
FLOAT(n) where $n \leq 21$	<i>distinct-type-name</i>	REAL	<i>distinct-type-name</i>
	<i>distinct-type-name</i>	DOUBLE	<i>distinct-type-name</i>
	REAL	<i>distinct-type-name</i>	REAL
FLOAT(n) where $n > 21$	<i>distinct-type-name</i>	DOUBLE	<i>distinct-type-name</i>
	DOUBLE	<i>distinct-type-name</i>	DOUBLE
FLOAT	<i>distinct-type-name</i>	DOUBLE	<i>distinct-type-name</i>
	DOUBLE	<i>distinct-type-name</i>	DOUBLE

Table 227. CAST functions on distinct types (continued)

Source type name	Function name	Parameter-type	Return-type
DOUBLE	<i>distinct-type-name</i>	DOUBLE	<i>distinct-type-name</i>
	DOUBLE	<i>distinct-type-name</i>	DOUBLE
DOUBLE PRECISION	<i>distinct-type-name</i>	DOUBLE	<i>distinct-type-name</i>
	<i>distinct-type-name</i>	CHAR (n)	<i>distinct-type-name</i>
	CHAR	<i>distinct-type-name</i>	CHAR (n)
	<i>distinct-type-name</i>	VARCHAR (n)	<i>distinct-type-name</i>
	DOUBLE	<i>distinct-type-name</i>	DOUBLE
CHAR CHARACTER	<i>distinct-type-name</i>	CHAR (n)	<i>distinct-type-name</i>
	CHAR	<i>distinct-type-name</i>	CHAR (n)
	<i>distinct-type-name</i>	VARCHAR (n)	<i>distinct-type-name</i>
VARCHAR CHARACTER VARYING CHAR VARYING	<i>distinct-type-name</i>	VARCHAR (n)	<i>distinct-type-name</i>
	VARCHAR	<i>distinct-type-name</i>	VARCHAR (n)
CLOB	<i>distinct-type-name</i>	CLOB (n)	<i>distinct-type-name</i>
	CLOB	<i>distinct-type-name</i>	CLOB (n)
GRAPHIC	<i>distinct-type-name</i>	GRAPHIC (n)	<i>distinct-type-name</i>
	GRAPHIC	<i>distinct-type-name</i>	GRAPHIC (n)
	<i>distinct-type-name</i>	VARGRAPHIC (n)	<i>distinct-type-name</i>
VARGRAPHIC	<i>distinct-type-name</i>	VARGRAPHIC (n)	<i>distinct-type-name</i>
	VARGRAPHIC	<i>distinct-type-name</i>	VARGRAPHIC (n)
DBCLOB	<i>distinct-type-name</i>	DBCLOB (n)	<i>distinct-type-name</i>
	DBCLOB	<i>distinct-type-name</i>	DBCLOB (n)
BINARY	<i>distinct-type-name</i>	BINARY(n)	<i>distinct-type-name</i>
	BINARY	<i>distinct-type-name</i>	BINARY(n)
	<i>distinct-type-name</i>	VARBINARY(n)	<i>distinct-type-name</i>
VARBINARY	<i>distinct-type-name</i>	VARBINARY(n)	<i>distinct-type-name</i>
	VARBINARY	<i>distinct-type-name</i>	VARBINARY(n)
BLOB	<i>distinct-type-name</i>	BLOB (n)	<i>distinct-type-name</i>
	BLOB	<i>distinct-type-name</i>	BLOB (n)
DATE	<i>distinct-type-name</i>	DATE	<i>distinct-type-name</i>
	DATE	<i>distinct-type-name</i>	DATE
TIME	<i>distinct-type-name</i>	TIME	<i>distinct-type-name</i>
	TIME	<i>distinct-type-name</i>	TIME

Table 227. CAST functions on distinct types (continued)

Source type name	Function name	Parameter-type	Return-type
TIMESTAMP	<i>distinct-type-name</i>	TIMESTAMP	<i>distinct-type-name</i>
	TIMESTAMP	<i>distinct-type-name</i>	TIMESTAMP(<i>p</i>) WITHOUT TIME ZONE
TIMESTAMP(<i>p</i>) WITH TIME ZONE	<i>distinct-type-name</i>	TIMESTAMP WITH TIME ZONE	<i>distinct-type-name</i>
	TIMESTAMP_TZ	<i>distinct-type-name</i>	TIMESTAMP(<i>p</i>) WITH TIME ZONE
ROWID	<i>distinct-type-name</i>	ROWID	<i>distinct-type-name</i>
	ROWID	<i>distinct-type-name</i>	ROWID

Notes: NUMERIC and FLOAT are not recommended when creating a distinct type for a portable application. Use DECIMAL and DOUBLE (or REAL) instead.

Built-in functions:

When a distinct type is defined, the built-in functions (such as AVG, MAX, and LENGTH) are not automatically supported for the distinct type. You can use a built-in function on a distinct type only after a sourced user-defined function, which is based on the built-in function, has been created for the distinct type. For information on defining sourced user-defined functions, see [“CREATE FUNCTION statement \(sourced function\)”](#) on page 1498.

Arithmetic operators with distinct type operands:

A distinct type cannot be used with arithmetic operators even if its base data type is numeric.

For additional information see [“Arithmetic with distinct type operands”](#) on page 256.

Alternative syntax and synonyms:

The WITH COMPARISONS clause, which specifies that system-generated comparison operators are to be created for comparing two instances of the distinct type, can be specified as the last clause of the statement. Use WITH COMPARISONS only if it is required for compatibility with other products in the Db2 family. If the base data type is either BLOB, CLOB, or DBCLOB and WITH COMPARISONS is specified, a warning occurs as in previous releases.

To provide compatibility with previous releases of Db2 or other products in the Db2 family, Db2 supports the following clauses:

- DISTINCT TYPE as a synonym for TYPE
- TIMEZONE can be specified as an alternative to TIME ZONE

Examples for CREATE TYPE (distinct)

Example 1

Create a distinct type named SHOESIZE that is based on an INTEGER data type.

```
CREATE TYPE SHOESIZE AS INTEGER;
```

The successful execution of this statement also generates two cast functions. Function INTEGER(SHOESIZE) returns a value with data type INTEGER, and function SHOESIZE(INTEGER) returns a value with distinct type SHOESIZE.

Example 2

Create a distinct type named MILES that is based on a DOUBLE data type.

```
CREATE TYPE MILES AS DOUBLE;
```

The successful execution of this statement also generates two cast functions. Function `DOUBLE(MILES)` returns a value with data type `DOUBLE`, and function `MILES(DOUBLE)` returns a value with distinct type `MILES`.

Related concepts

[Distinct types \(Introduction to Db2 for z/OS\)](#)

[Naming conventions](#)

The rules for forming a name depend on the type of the object designated by the name.

Related tasks

[Creating a distinct type \(Db2 Application programming and SQL\)](#)

CREATE VARIABLE statement

The `CREATE VARIABLE` statement creates a global variable at the current server.

Invocation for CREATE VARIABLE

This statement can be embedded in an application program or issued interactively. It is an executable statement that can be dynamically prepared only if `DYNAMICRULES RUN` behavior is in effect. For more information, see [“Authorization IDs and dynamic SQL” on page 94](#).

Authorization for CREATE VARIABLE

The privilege set that is defined below must include at least one of the following:

- The `CREATEIN` privilege on the schema
- System `DBADM` authority
- `SYSADM` authority
- `SYSCTRL` authority
- Installation `SYSOPR` authority (when the current `SQLID` of the process is set to `SYSINSTL`)

Privilege set: The authorization ID that matches the schema name implicitly has the `CREATEIN` privilege on the schema. If the statement is embedded in an application program, the privilege set is the set of privileges that are held by the owner of the package. If the owner is a role, the implicit schema does not apply and this role needs to include one of the previously listed privileges or authorities.

If the statement is dynamically prepared, the privilege set is the privileges that are held by the `SQL` authorization ID of the process unless the process is within a trusted context and the `ROLE AS OBJECT OWNER AND QUALIFIER` clause is in effect. If the schema name is not the same as the `SQL` authorization ID of the process, one of the following conditions must be met:

- The privilege set includes `SYSADM` or `SYSCTRL` authority.
- The `SQL` authorization ID of the process has the `CREATEIN` privilege on the schema.

When the `ROLE AS OBJECT OWNER AND QUALIFIER` clause is in effect, the privilege set is the set of privileges that are held by the role. If the schema name does not match this role, one of the following conditions must be met:

- The privilege set includes `SYSADM` or `SYSCTRL` authority.
- This role has the `CREATEIN` privilege on the schema.

Syntax for CREATE VARIABLE

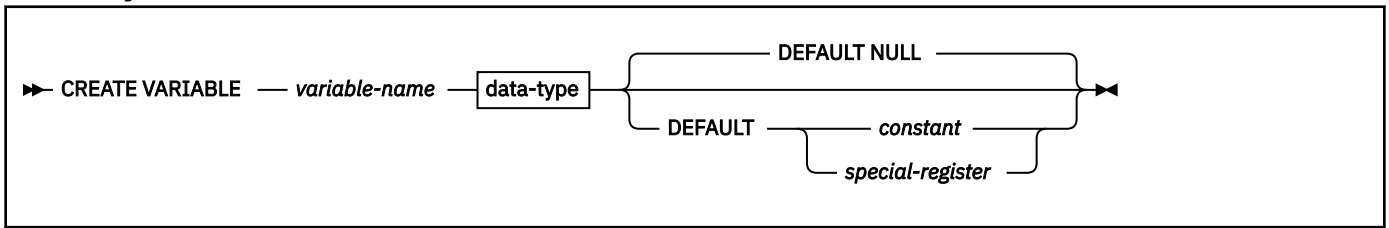

data-type:



built-in-type:

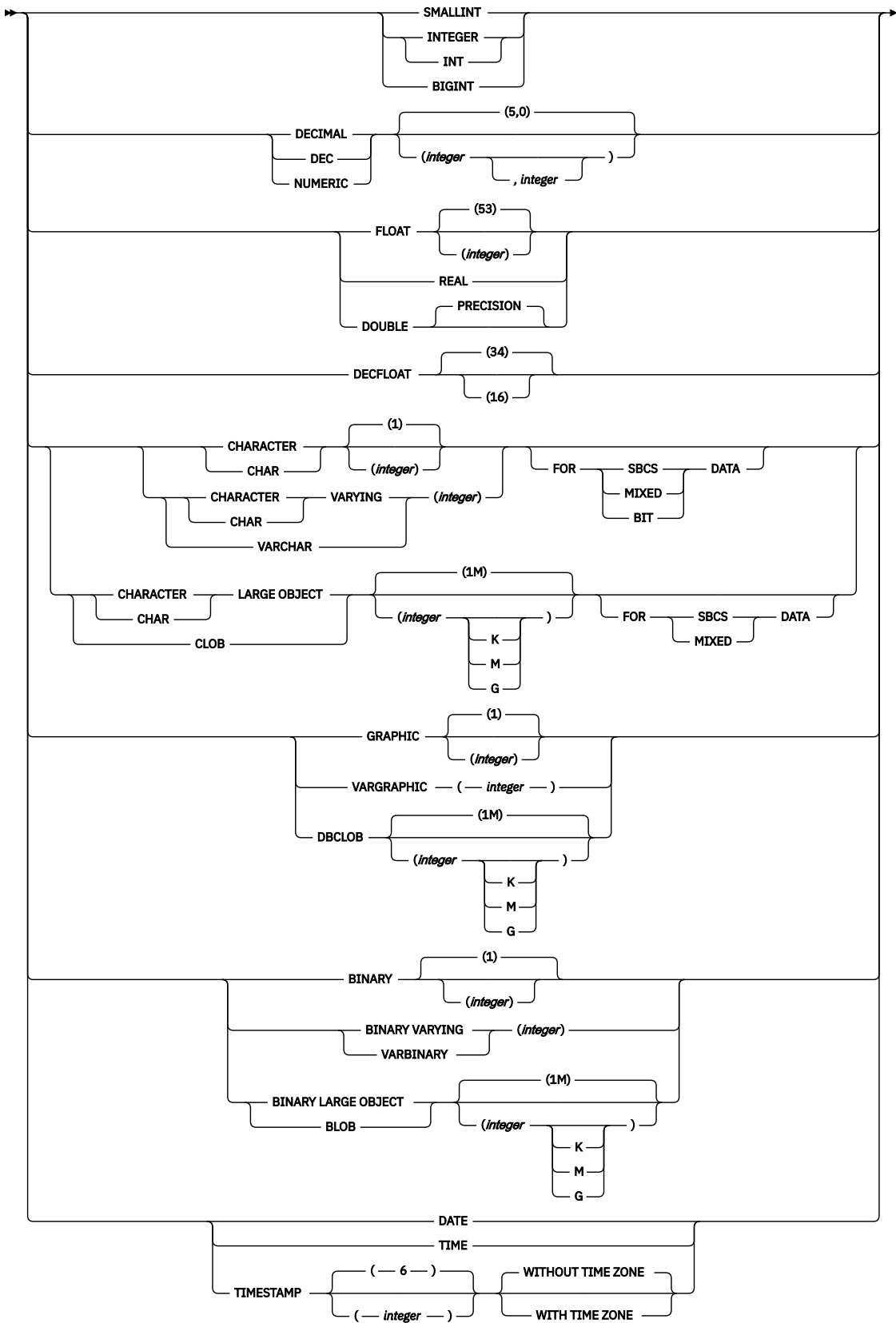

Description for CREATE VARIABLE

variable-name

Names the global variable. The name, including the implicit or explicit qualifier, must not identify a global variable that exists at the current server. If the qualifier is not specified, the contents of the CURRENT SCHEMA special register is used.

The schema name must not begin with 'SYS' unless the schema name is 'SYSADM'.

data-type

Specifies the data type of the global variable.

built-in-type

The data type of the global variable is a built-in type. For information about the data types, see [built-in-type](#). The data type cannot be ROWID or XML.

array-type-name

Specifies the name of a user-defined array type. The variable is an array that is defined with the [“CREATE TYPE statement \(array type\)”](#) on page 1795 statement.

If you specify *array-type-name* without a schema name, Db2 resolves the array type by searching the schemas in the SQL path.

An array type with elements that are defined as character strings must be defined with CCSID UNICODE.

DEFAULT, DEFAULT NULL, DEFAULT *constant*, or DEFAULT *special-register*

The default value that is assigned to the global variable if a value is not explicitly specified. Specifies a value for the global variable when it is first referenced in the session. The default value is determined on this first reference. If the DEFAULT clause is not specified, the default for the global variable is the null value. Only DEFAULT NULL can be explicitly specified if *array-type-name* is specified.

DEFAULT NULL

Specifies null as the default value for the global variable. The value of a global variable is always nullable.

DEFAULT constant

Specifies that the value of the constant is the default value for the global variable. The value of the constant must conform to the rules for assigning that value to the global variable. *constant* cannot be any of the constants NAN, SNAN, or INFINITY.

DEFAULT special-register

Specifies that the value of the special register, when the global variable is instantiated, is used as the default value of the global variable. The value of the specified special register must conform to the rules for assigning that value to the global variable. The following special registers must not be specified:

- CURRENT GET_ACCEL_ARCHIVE
- CURRENT QUERY_ACCELERATION
- CURRENT TEMPORAL BUSINESS_TIME
- CURRENT TEMPORAL SYSTEM_TIME

Notes for CREATE VARIABLE

Session scope:

Global variables have a session scope. Although they are available for use to all sessions that are active at the current server, the value of the global variable is private for each session.

Modifications to the value of a global variable:

Global variables are not under transaction control. Modifications to the value of a global variable are not affected by either a COMMIT or ROLLBACK statement.

Privileges to use a global variable:

Reading from or writing to a global variable requires that the authorization ID or role that is in effect have the appropriate privileges on the global variable. The owner of the variable is implicitly granted all privileges on the variable.

Setting the default value:

After a global variable has been created, it is instantiated to its default value when it is first referenced within a given scope. If a global variable is referenced within a statement, it is instantiated independently from the execution of that statement.

Using a newly created global variable:

If a global variable is created within a session, it cannot be used by other sessions until the unit of work has committed. However, the newly created global variable can be used within the session in which it is created before the unit of work commits.

Examples for CREATE VARIABLE

Example 1: Create a global variable to indicate what printer to use for the session.

```
CREATE VARIABLE MYSCHEMA.MYJOB_PRINTER VARCHAR(30)
  DEFAULT 'Default printer';
```

Example 2: Create a global variable to indicate the department where an employee works.

```
CREATE VARIABLE SCHEMA1.GV_DEPTNO INTEGER
  DEFAULT 'Unassigned';
```

Example 3: Create user-defined array type myArrayIntType as an array of integers. Create global variable myGlobalVar with type myArrayIntType.

```
CREATE TYPE myArrayIntType AS INT ARRAY[];
CREATE VARIABLE myGlobalVar myArrayIntType;
```

CREATE VIEW statement

The CREATE VIEW statement creates a view on tables or views at the current server.

Invocation for CREATE VIEW

This statement can be embedded in an application program or issued interactively. It is an executable statement that can be dynamically prepared only if DYNAMICRULES RUN behavior is in effect. For more information, see [“Authorization IDs and dynamic SQL” on page 94](#).

Authorization for CREATE VIEW

For every table or view identified in the *fullselect*, the privilege set that is defined below must include at least one of the following:

- The SELECT privilege on the table or view
- Ownership of the table or view
- DBADM authority for the database (tables only)
- DATAACCESS authority
- SYSADM authority
- SQLADM authority (catalog tables only)
- System DBADM authority (catalog tables only)
- ACCESSCTRL authority (catalog tables only)
- SYSCTRL authority (catalog tables only)
- SECADM authority (catalog tables only)

If the database is implicitly created, the database privileges must be on the implicit database or on DSNDB04.

Authority requirements depend in part on the choice of the owner of the view. For information on how to choose the owner, see the description of *view-name* in “ALTER VIEW statement” on page 1378.

Privilege set: If the statement is embedded in an application program, the privilege set is the privileges that are held by the owner of the plan or package. If the application is bound in a trusted context with the ROLE AS OBJECT OWNER clause specified, a role is the owner. Otherwise, an authorization ID is the owner.

- If this privilege set includes SYSADM authority, the owner of the view can be any authorization ID. If that set includes SYSCTRL but not SYSADM authority, the following is true: the owner of the view can be any authorization ID, provided the view does not refer to user tables or views in the first FROM clause of its defining fullselect. (It could refer instead, for example, to catalog tables or views thereof.)

If the view satisfies the rules in the preceding paragraph, and if no errors are present in the CREATE statement, the view is created, even if the owner has no privileges at all on the tables and views identified in the fullselect of the view definition.

- If the privilege set includes system DBADM authority, the owner of the view can be any authorization ID. However, to create a view on a user table, either the owner of the view or the creator must have the SELECT privilege on all the tables or views in the CREATE VIEW statement.
- If the privilege set lacks system DBADM, SYSADM and SYSCTRL but includes DBADM authority on at least one of the databases that contains a table from which the view is created, the owner of the view can be any authorization ID if all of the following conditions are true:
 - The value of subsystem parameter DBACRVW is set to YES.
 - The view is not based only on views.

Note: The owner of the view must have the SELECT privilege on all tables and views in the CREATE VIEW statement, or, if the owner does not have the SELECT privilege on a table, the creator must have DBADM authority on the database that contains that table.

- If the privilege set lacks SYSADM, SYSCTRL, system DBADM, and DBADM authority, or if the authorization ID of the application plan or package fails to meet any of the previous conditions, the owner of the view must be the owner of the application plan or package.

If ROLE AS OBJECT OWNER is in effect, the schema qualifier must be the same as the role, unless the role has the CREATEIN privilege on the schema, SYSADM authority, system DBADM authority, or SYSCTRL authority.

If ROLE AS OBJECT OWNER is not in effect, one of the following rules applies:

- If the privilege set lacks the CREATIN privilege on the schema, SYSADM authority, system DBADM authority, or SYSCTRL authority, the schema qualifier (implicit or explicit) must be the same as one of the authorization ids of the process.
- If the privilege set includes system DBADM authority, SYSADM authority or SYSCTRL authority, the schema qualifier can be any valid schema name.

If the statement is dynamically prepared, the following rules apply:

- If the SQL authorization ID of the process has SYSADM authority, the owner of the view can be any authorization ID. If that authorization ID has SYSCTRL but not SYSADM authority, the following is true: the owner of the view can be any authorization ID, provided the view does not refer to user tables or views in the first FROM clause of its defining fullselect. (It could refer instead, for example, to catalog tables or views thereof.)

If the view satisfies the rules in the preceding paragraph, and if no errors are present in the CREATE statement, the view is created, even if the owner has no privileges at all on the tables and views identified in the fullselect of the view definition.

- If the SQL authorization ID of the process has system DBADM authority, the owner of the view can be any authorization ID. However, to create a view on a user table, either the owner of the view or the

SQL authorization ID must have the SELECT privilege on all the tables or views in the CREATE VIEW statement.

- If SQL authorization ID of the process lacks system DBADM authority, SYSADM and SYSCTRL but includes DBADM authority on at least one of the databases that contains a table from which the view is created, the owner of the view can be different from the SQL authorization ID if all of the following conditions are true:
 - The value of field DBADM CREATE AUTH was set to YES on panel DSNTIPP during Db2 installation.
 - The view is not based only on views.

Note: The owner of the view must have the SELECT privilege on all tables and views in the CREATE VIEW statement, or, if the owner does not have the SELECT privilege on a table, the creator must have DBADM authority on the database that contains that table.

- If the SQL authorization ID of the process lacks SYSADM, SYSCTRL, system DBADM authority, or DBADM authority, or if the SQL authorization ID of the process fails to meet any of the previous conditions, only the authorization IDs of the process can own the view. In this case, the privilege set is the privileges that are held by the authorization ID selected for ownership.

Syntax for CREATE VIEW

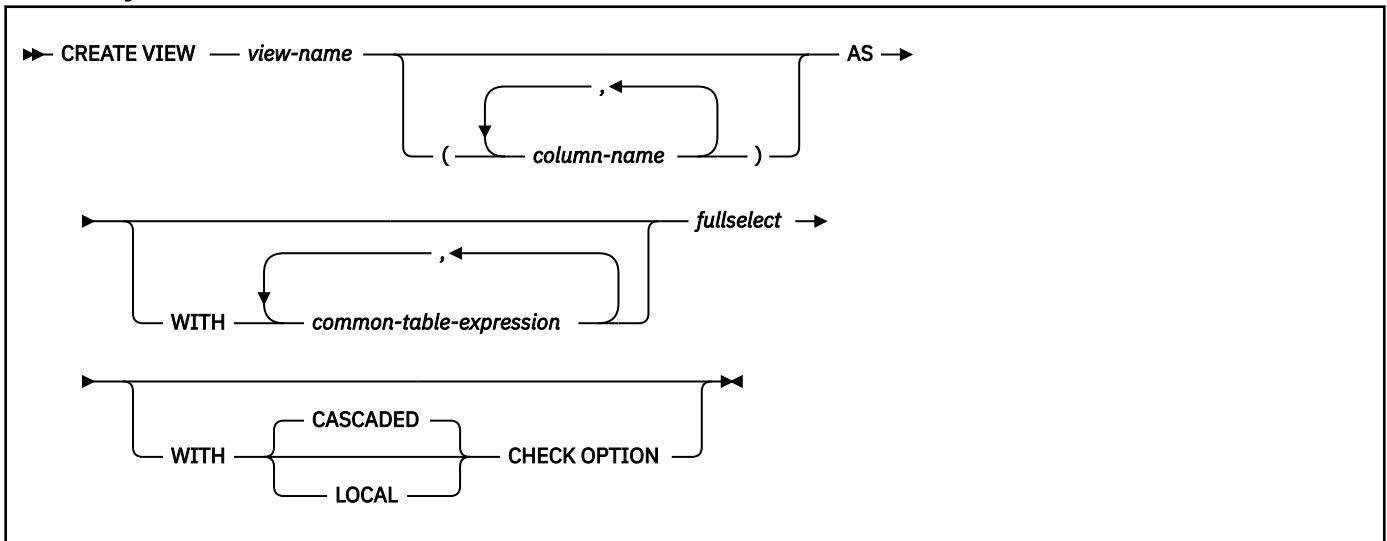

Description for CREATE VIEW

view-name

Names the view. The name, including the implicit or explicit qualifier, must not identify a table, view, alias, or synonym that exists at the current server or a table that exists in the SYSIBM.SYSPENDINGOBJECTS catalog table. The unqualified name must not be the same as an existing synonym.

If the name is qualified, the name can be a two-part or three-part name. If a three-part name is used, the first part must match the value of the field Db2 LOCATION NAME of installation panel DSNTIPR at the current server. (If the current server is not the local Db2, this name is not necessarily the name in the CURRENT SERVER special register.)

column-name,...

Names the columns in the view. If you specify a list of column names, it must consist of as many names as there are columns in the result table of the fullselect. Each name must be unique and unqualified. If you do not specify a list of column names, the columns of the view inherit the names of the columns of the result table of the fullselect.

You must specify a list of column names if the result table of the fullselect has duplicate column names or an unnamed column (a column derived from a constant, function, or expression that was not

given a name by the AS clause). For more details about unnamed columns, see the information about names of result columns under [“select-clause” on page 1010](#).

AS

Identifies the view definition.

WITH common-table-expression

Defines a common table expression for use with the fullselect that follows. The fullselect must not contain a period specification. For an explanation of common table expression, see [“common-table-expression” on page 1069](#).

fullselect

Defines the view. At any time, the view consists of the rows that would result if the fullselect were executed.

The *fullselect* must conform to the following rules:

- The *fullselect* must not refer to any host variables or parameter markers (question marks), but can refer to global variables.
- The *fullselect* must not refer to any declared temporary tables.
- The *fullselect* must not include an invocation of the UNPACK function.
- The *fullselect* must not contain a period specification.
- The FROM clause of the *fullselect* must not include a *data-change-table-reference*.
- The FROM clause of the *fullselect* must not include a view for which an INSTEAD OF trigger is defined.
- The outer SELECT list of the outer *fullselect* must not result in a column that is an array.

For an explanation of *fullselect*, see [“fullselect” on page 1060](#).

WITH CASCADED CHECK OPTION or WITH LOCAL CHECK OPTIONS

Specifies that every row that is inserted or updated through the view must conform to the definition of the view. A row that does not conform to the definition of the view is a row that cannot be retrieved using that view.

The CHECK OPTION clause must not be specified if the view is read-only, includes a subquery, references a function that is not deterministic or has an external action, or if the fullselect of the view refers to a created temporary table. If the CHECK OPTION clause is specified for an updatable view that does not allow inserts, it applies to updates only.

If the CHECK OPTION clause is omitted, the definition of the view is not used in the checking of any insert or update operations that use the view. Some checking might still occur during insert or update operations if the view is directly or indirectly dependent on another view that includes the CHECK OPTION clause. Because the definition of the view is not used, rows might be inserted or updated through the view that do not conform to the definition of the view.

The difference between the two forms of the check option, CASCADED and LOCAL, is meaningful only when a view is dependent on another view. The default is CASCADED. The view on which another view is directly or indirectly defined is an *underlying view*.

CASCADED

Update and insert operations on view V must satisfy the search conditions of view V and all underlying views, regardless of whether the underlying views were defined with a check option. Furthermore, every updatable view that is directly or indirectly defined on view V inherits those search conditions (the search conditions of view V and all underlying views of V) as a constraint on insert or update operations. WITH CASCADED CHECK OPTION must not be specified if a view on which the specified view definition is dependent has an INSTEAD OF trigger defined.

LOCAL

Update and insert operations on view V must satisfy the search conditions of view V and underlying views that are defined with a check option (either WITH CASCADED CHECK OPTION or WITH LOCAL CHECK OPTION). Furthermore, every updatable view that is directly or indirectly defined on view V inherits those search conditions (the search conditions of view V and all

underlying views of V that are defined with a check option) as a constraint on insert or update operations.

The LOCAL form of the CHECK option lets you update or insert rows that do not conform to the search condition of view V. You can perform these operations if the view is directly or indirectly defined on a view that was defined without a check option.

Table 228 on page 1816 illustrates the effect of using the default check option, CASCADED. The information in Table 228 on page 1816 is based on the following views:

- CREATE VIEW V1 AS SELECT COL1 FROM T1 WHERE COL1 > 10
- CREATE VIEW V2 AS SELECT COL1 FROM V1 WITH CASCADED CHECK OPTION
- CREATE VIEW V3 AS SELECT COL1 FROM V2 WHERE COL1 < 100

Table 228. Examples using default check option, CASCADED

SQL statement	Description of result
INSERT INTO V1 VALUES(5)	Succeeds because V1 does not have a check option and it is not dependent on any other view that has a check option.
INSERT INTO V2 VALUES(5)	Results in an error because the inserted row does not conform to the search condition of V1 which is implicitly is part of the definition of V2.
INSERT INTO V3 VALUES(5)	Results in an error because the inserted row does not conform to the search condition of V1.
INSERT INTO V3 VALUES(200)	Succeeds even though it does not conform to the definition of V3 (V3 does not have the view check option specified); it does conform to the definition of V2 (which does have the view check option specified).

The difference between CASCADED and LOCAL is shown best by example. Consider the following updatable views, where x and y represent either LOCAL or CASCADED:

- V1 is defined on Table T0.
- V2 is defined on V1 WITH x CHECK OPTION.
- V3 is defined on V2.
- V4 is defined on V3 WITH y CHECK OPTION.
- V5 is defined on V4.

This example shows V1 as an *underlying view* for V2 and V2 as *dependent* on V1.

Table 229 on page 1816 shows the views in which search conditions are checked during an insert or update operation:

Table 229. Views in which search conditions are checked during insert and update operations

View used in INSERT or UPDATE operation	x = LOCAL y = LOCAL	x = CASCADED y = CASCADED	x = LOCAL y = CASCADED	x = CASCADED y = LOCAL
V1	None	None	None	None
V2	V2	V2, V1	V2	V2, V1
V3	V2	V2, V1	V2	V2, V1
V4	V4, V2	V4, V3, V2, V1	V4, V3, V2, V1	V4, V2, V1
V5	V4, V2	V4, V3, V2, V1	V4, V3, V2, V1	V4, V2, V1

Notes for CREATE VIEW

Owner privileges

The owner of a view always acquires the SELECT privilege on the view and the authority to drop the view. If all of the privileges that are required to create the view are held with the GRANT option before the view is created, the owner of the view receives the SELECT privilege with the GRANT option. Otherwise, the owner receives the SELECT privilege without the GRANT option. For example, assume that a view definition also refers to a user-defined function. If the owner's EXECUTE privilege on the user-defined function is held without the GRANT option, the owner acquires the SELECT privilege on the view without the GRANT option.

The owner can also acquire INSERT, UPDATE, and DELETE privileges on the view. Acquiring these privileges is possible if the view is not "read-only", which means a single table of view is identified in the first FROM clause of the fullselect. For each privilege that the owner has on the identified table or view (INSERT, UPDATE, and DELETE) before the new view is created, the owner acquires that privilege on the view. The owner receives the privilege with the GRANT option if the privilege is held on the table or view with the GRANT option. Otherwise, the owner receives the privileges without the GRANT option.

With appropriate Db2 authority, a process can create views for those who have no authority to create the views themselves. The owner of such a view has the SELECT privilege on the view, without the GRANT option, and can drop the view.

For more information on the ownership of an object, see [“Authorization, privileges, permissions, masks, and object ownership”](#) on page 90.

Authorization for views created for other users

When a process with appropriate authority creates a view for another user that does not have authorization for the underlying table or view, the SELECT privilege for the created view is implicitly granted to the user.

Considerations for row access control and column access control

The view definition might reference a table for which row access control or column access control is activated. If the view definition references a table for which row access control or column access control is activated, the WITH CHECK OPTION clause must not be specified if the search conditions from the view or from the underlying views will be checked during an insert or update operation. Note that the WITH CHECK OPTION clause is ignored if such search conditions do not exist.

Read-only views

A view is *read-only* if one or more of the following statements is true of its definition:

- The first FROM clause identifies more than one table or view, or identifies a table function, a nested table expression, a common table expression, or a collection-derived table.
- The first SELECT clause specifies the keyword DISTINCT.
- The outer fullselect contains a GROUP BY clause.
- The outer fullselect contains a HAVING clause.
- The first SELECT clause contains an aggregate function.
- It contains a subquery such that the base object of the outer fullselect, and of the subquery, is the same table.
- The first FROM clause identifies a read-only view.
- The first FROM clause identifies a system-maintained materialized query table.
- The outer fullselect is not a subselect (contains a set operator).

A read-only view cannot be the object of an SQL data change statement or a TRUNCATE statement. A view that includes GROUP BY or HAVING cannot be referred to in a subquery of a basic predicate.

Insertable views

A view is insertable if an INSTEAD OF trigger for the insert operation has been defined for the view, or if at least one column of the view is updatable (independent of an INSTEAD OF trigger for update).

Considerations for implicitly hidden columns

It is possible that the result table of the fullselect will include a column of a base table that is defined as implicitly hidden. This can occur when the implicitly hidden column is explicitly referenced in the fullselect of the view definition. However, the corresponding column of the view does not inherit the implicitly hidden attribute. Columns of a view cannot be defined as hidden.

Testing a view definition

You can test the semantics of your view definition by executing `SELECT * FROM view-name`.

The two forms of a view definition

Both the source and the operational form of a view definition are stored in the Db2 catalog. Those two forms are not necessarily equivalent because the operational form reflects the state that exists when the view is created. For example, consider the following statement:

```
CREATE VIEW V AS SELECT * FROM S;
```

In this example, S is a synonym or alias for A.T, which is a table with columns C1, C2, and C3[®]. The operational form of the view definition is equivalent to:

```
SELECT C1, C2, C3 FROM A.T;
```

Adding columns to A.T using ALTER TABLE and dropping S does not affect the operational form of the view definition. Thus, if columns are added to A.T or if S is redefined, the source form of the view definition can be misleading.

View restrictions

A view definition cannot contain references to remote objects. A view definition cannot map to more than 15 base table instances. A view definition cannot reference a declared global temporary table.

Restrictions involving pending definition changes

CREATE VIEW is not allowed if the view references a column on which there are pending definition changes.

Considerations for inline LOB columns

If the view references a table that contains an inline LOB column and Db2 determines that the inline attribute can be passed on to the view, the view will then inherit the inline attribute, otherwise the inline attribute is not inherited by the view.

Considerations for XML columns

If the view has an XML column and the column of the underlying base table for the view has an XML type modifier, the view column has the same type modifier. However, if there is an instead of trigger defined on the view, validation of the column, according to XML schemas in the type modifier, is not enforced during insert or update to this view.

Examples for CREATE VIEW

Example 1

Create the view DSN8C10.VPROJRE1. PROJNO, PROJNAME, PROJDEP, RESPEMP, FIRSTNME, MIDINIT, and LASTNAME are column names. The view is a join of tables and is therefore read-only.

```
CREATE VIEW DSN8C10.VPROJRE1
  (PROJNO, PROJNAME, PROJDEP, RESPEMP,
   FIRSTNME, MIDINIT, LASTNAME)
AS SELECT ALL
  PROJNO, PROJNAME, DEPTNO, EMPNO,
  FIRSTNME, MIDINIT, LASTNAME
FROM DSN8C10.PROJ, DSN8C10.EMP
WHERE RESPEMP = EMPNO;
```

In the example, the WHERE clause refers to the column EMPNO, which is contained in one of the base tables but is not part of the view. In general, a column named in the WHERE, GROUP BY, or HAVING clause need not be part of the view.

Example 2

Create the view DSN8C10.FIRSTQTR that is the UNION ALL of three fullselects, one for each month of the first quarter of 2000. The common names are SNO, CHARGES, and DATE.

```
CREATE VIEW DSN8C10.FIRSTQTR (SNO, CHARGES, DATE) AS
SELECT SNO, CHARGES, DATE
FROM MONTH1
WHERE DATE BETWEEN '01/01/2000' and '01/31/2000'
UNION ALL
SELECT SNO, CHARGES, DATE
FROM MONTH2
WHERE DATE BETWEEN '02/01/2000' and '02/29/2000'
UNION ALL
SELECT SNO, CHARGES, DATE
FROM MONTH3
WHERE DATE BETWEEN '03/01/2000' and '03/31/2000';
```

Related concepts

[Db2 views \(Introduction to Db2 for z/OS\)](#)

[Naming conventions](#)

The rules for forming a name depend on the type of the object designated by the name.

Related tasks

[Creating Db2 views \(Db2 Administration Guide\)](#)

DECLARE CURSOR statement

The DECLARE CURSOR statement defines a cursor.

Invocation for DECLARE CURSOR

This statement can only be embedded in an application program. It is not an executable statement. It must not be specified in Java.

Authorization for DECLARE CURSOR

For each table or view identified in the SELECT statement of the cursor, the privilege set must include at least one of the following:

- The SELECT privilege
- Ownership of the object
- DBADM authority for the corresponding database (tables only)
- SYSADM authority
- SYSCTRL authority (catalog tables only)
- DATAACCESS authority

If the *select-statement* contains an SQL data change statement, the authorization requirements of that statement also apply to the DECLARE CURSOR statement.

The SELECT statement of the cursor is one of the following:

- The prepared select statement identified by *statement-name*
- The specified *select-statement*

If *statement-name* is specified:

- The privilege set is determined by the DYNAMICRULES behavior in effect (run, bind, define, or invoke) and is summarized in [Table 171 on page 1089](#). (For more information on these behaviors, including a list of the DYNAMICRULES bind option values that determine them, see [“Authorization IDs and dynamic SQL” on page 94](#).)
- The authorization check is performed when the SELECT statement is prepared.

- The cursor cannot be opened unless the SELECT statement is successfully prepared.

If select-statement is specified:

- The privilege set consists of the privileges that are held by the authorization ID of the owner of the plan or package.
- If the plan or package is bound with VALIDATE(BIND), the authorization check is performed at bind time, and the bind is unsuccessful if any required privilege does not exist.
- If the plan or package is bound with VALIDATE(RUN), an authorization check is performed at bind time, but all required privileges need not exist at that time. If all privileges exist at bind time, no authorization checking is performed when the cursor is opened. If any privilege does not exist at bind time, an authorization check is performed the first time the cursor is opened within a unit of work. The OPEN is unsuccessful if any required privilege does not exist.

Syntax for DECLARE CURSOR

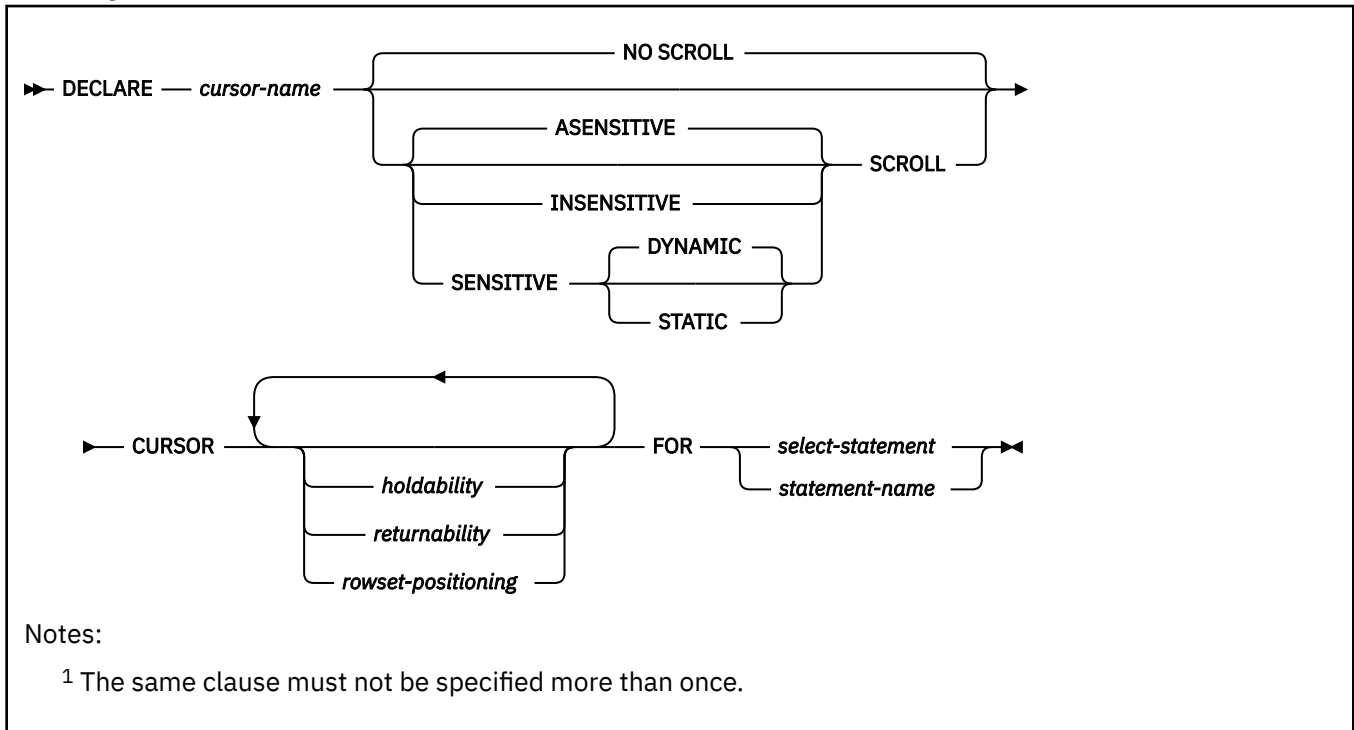

holdability:



returnability:

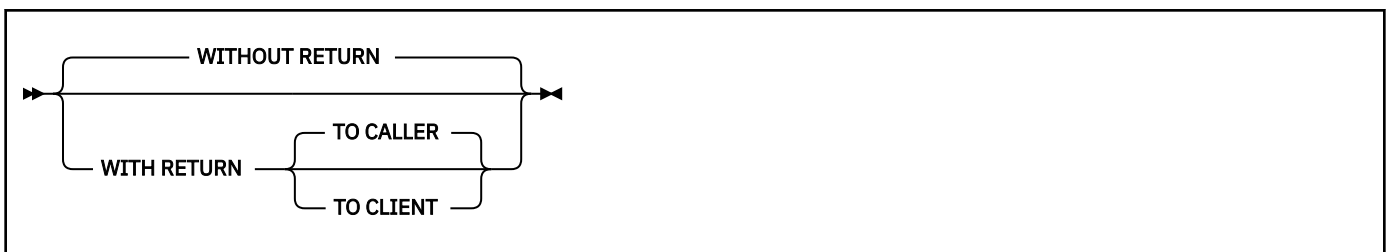

rowset-positioning:



Description for DECLARE CURSOR

cursor-name

Names the cursor. The name must not identify a cursor that has already been declared in the source program. The name is usually VARCHAR(128); however, if the cursor is defined WITH RETURN, the name is limited to VARCHAR(30).

NO SCROLL or SCROLL

Specifies whether the cursor is scrollable or not scrollable.

NO SCROLL

Specifies that the cursor is not scrollable. This is the default.

SCROLL

Specifies that the cursor is scrollable. For a scrollable cursor, whether the cursor has sensitivity to inserts, updates, or deletes depends on the cursor sensitivity option in effect for the cursor. If a sensitivity option is not specified, ASENSITIVE is the default.

ASENSITIVE

Specifies that the cursor should be as sensitive as possible. This is the default.

A cursor that defined as ASENSITIVE will be either insensitive or sensitive dynamic; it will not be sensitive static. For information about how the effective sensitivity of the cursor is returned to the application with the GET DIAGNOSTICS statement or in the SQLCA, see [“OPEN statement” on page 2037](#).

The sensitivity of a cursor is a factor in the choice of access path. Explicitly specify the sensitivity level that you need, instead of specifying ASENSITIVE.

INSENSITIVE

Specifies that the cursor does not have sensitivity to inserts, updates, or deletes that are made to the rows underlying the result table. As a result, the size of the result table, the order of the rows, and the values for each row do not change after the cursor is opened. In addition, the cursor is read-only. The SELECT statement or *attribute-string* of the PREPARE statement cannot contain a FOR UPDATE clause, and the cursor cannot be used for positioned updates or deletes.

SENSITIVE

Specifies that the cursor has sensitivity to changes that are made to the database after the result table is materialized. The cursor is always sensitive to updates and deletes that are made using the cursor (that is, positioned updates and deletes using the same cursor). When the current value of a row no longer satisfies the *select-statement* or *statement-name*, that row is no longer visible through the cursor. When a row of the result table is deleted from the underlying base table, the row is no longer visible through the cursor.

If Db2 cannot make changes visible to the cursor, then an error is issued at bind time for OPEN CURSOR. Db2 cannot make changes visible to the cursor when the cursor implicitly becomes read-only. For example, when the result table must be materialized, as when the FROM clause of the SELECT statement contains more than one table or view. The current list of conditions that result in an implicit read-only cursor can be found in [Read-only cursors](#).

The default is DYNAMIC.

DYNAMIC

Specifies that the result table of the cursor is dynamic, meaning that the size of the result table might change after the cursor is opened as rows are inserted into or deleted from the underlying table, and the order of the rows might change. Rows that are inserted,

deleted, or updated by statements that are executed by the same application process as the cursor are visible to the cursor immediately. Rows that are inserted, deleted, or updated by statements that are executed by other application processes are visible only after the statements are committed. If a column for an ORDER BY clause is updated via a cursor or any means outside the process, the next FETCH statement behaves as if the updated row was deleted and re-inserted into the result table at its correct location. At the time of a positioned update, the cursor is positioned before the next row of the original location and there is no current row, making the row appear to have moved.

If a SENSITIVE DYNAMIC cursor is not possible, an error is returned. For example, if a temporary table is needed an error is returned. The SELECT statement of a cursor that is defined as SENSITIVE DYNAMIC cannot contain an SQL data change statement.

The *offset-clause* and the *fetch-clause* must not be specified for the outermost fullselect for a sensitive dynamic cursor.

STATIC

Specifies that the size of the result table and the order of the rows do not change after the cursor is opened. Rows inserted into the underlying table are not added to the result table regardless of how the rows are inserted. Rows in the result table do not move if columns in the ORDER BY clause are updated in rows that have already been materialized. Positioned updates and deletes are allowed if the result table is updatable. The SELECT statement of a cursor that is defined as SENSITIVE STATIC cannot contain an SQL data change statement.

A STATIC cursor has visibility to changes made by *this* cursor using positioned updates or deletes. Committed changes made outside this cursor are visible with the SENSITIVE option of the FETCH statement. A FETCH SENSITIVE can result in a *hole* in the result table (that is, a difference between the result table and its underlying base table). If an updated row in the base table of a cursor no longer satisfies the predicate of its SELECT statement, an update hole occurs in the result table. If a row of a cursor was deleted in the base table, a delete hole occurs in the result table. When a FETCH SENSITIVE detects an update hole, no data is returned (a warning is issued), and the cursor is left positioned on the update hole. When a FETCH SENSITIVE detects a delete hole, no data is returned (a warning is issued), and the cursor is left positioned on the delete hole.

Updates through a cursor result in an automatic re-fetch of the row. This re-fetch means that updates can create a hole themselves. The re-fetched row also reflects changes as a result of triggers updating the same row. It is important to reflect these changes to maintain the consistency of data in the row.

Using a function that is not deterministic (built-in or user-defined) in the WHERE clause of the *select-statement* or *statement-name* of a SENSITIVE STATIC cursor can cause misleading results. This situation occurs because Db2 constructs a temporary result table and retrieves rows from this table for FETCH INSENSITIVE statements. When Db2 processes a FETCH SENSITIVE statement, rows are fetched from the underlying table and predicates are re-evaluated. Using a function that is not deterministic can yield a different result on each FETCH SENSITIVE of the same row, which could also result in the row no longer being considered a match.

A FETCH INSENSITIVE on a SENSITIVE STATIC SCROLL cursor is not sensitive to changes made outside the cursor, unless a previous FETCH SENSITIVE has already refreshed that row; however, positioned updates and delete changes with the cursor are visible.

STATIC cursors are insensitive to insertions.

WITHOUT HOLD or WITH HOLD

Specifies whether the cursor should be prevented from being closed as a consequence of a commit operation.

WITHOUT HOLD

Does not prevent the cursor from being closed as a consequence of a commit operation. This is the default.

WITH HOLD

Prevents the cursor from being closed as a consequence of a commit operation. A cursor declared with WITH HOLD is closed at commit time if one of the following is true:

- The connection associated with the cursor is in the release pending status.
- The bind option DISCONNECT(AUTOMATIC) is in effect.
- The environment is one in which the option WITH HOLD is ignored.

When WITH HOLD is specified, a commit operation commits all of the changes in the current unit of work. For example, with a non-scrollable cursor, an initial FETCH statement is needed after a COMMIT statement to position the cursor on the row that follows the row that the cursor was positioned on before the commit operation.

WITH HOLD has no effect on an SQL data change statement within a SELECT statement. When a COMMIT is issued, the changes caused by the SQL data change statement are committed, regardless of whether or not the cursor is declared WITH HOLD.

All cursors are implicitly closed by a connect (Type 1) or rollback operation. A cursor is also implicitly closed by a commit operation if WITH HOLD is ignored or not specified.

Cursors that are declared with WITH HOLD in CICS or in IMS non-message-driven programs will not be closed by a rollback operation if the cursor was opened in a previous unit of work and no changes have been made to the database in the current unit of work. The cursor cannot be closed because CICS and IMS do not broadcast the rollback request to Db2 for a null unit of work.

If a cursor is closed before the commit operation, the effect is the same as if the cursor was declared without the option WITH HOLD.

WITH HOLD is ignored in IMS message driven programs (MPP, IFP, and message-driven BMP). WITH HOLD maintains the cursor position in a CICS pseudo-conversational program until the end-of-task (EOT).

For details on restrictions that apply to declaring cursors with WITH HOLD, see [Held and non-held cursors \(Db2 Application programming and SQL\)](#).

WITHOUT RETURN or WITH RETURN

Specifies whether the result table of the cursor is intended to be used as a result set that will be returned from a procedure. If *statement-name* is specified, the default is the corresponding prepare attribute of the statement. Otherwise, the default is WITHOUT RETURN.

WITHOUT RETURN

Specifies that the result table of the cursor is not intended to be used as a result set that will be returned from a procedure.

WITH RETURN

Specifies that the result table of the cursor is intended to be used as a result set that will be returned from a procedure. WITH RETURN is relevant only if the DECLARE CURSOR statement is contained within the source code for a procedure. In other cases, the precompiler might accept the clause, but it has no effect.

When a cursor that is declared using the WITH RETURN TO CALLER clause remains open at the end of a program or routine, that cursor defines a result set from the program or routine. Use the CLOSE statement to close a cursor that is not intended to be a result set from the program or routine. Although Db2 will automatically close any cursors that are not declared using with a WITH RETURN clause, the use of the CLOSE statement is recommended to increase the portability of applications.

For non-scrollable cursors, the result set consists of all rows from the current cursor position to the end of the result table. For scrollable cursors, the result set consists of all rows of the result table.

TO CALLER

Specifies that the cursor can return a result set to the caller of the procedure. The caller is the program or routine that executed the SQL CALL statement that invokes the procedure that

contains the DECLARE CURSOR statement. For example, if the caller is a procedure, the result set, is returned to the procedure. If the caller is a client application, the result set is returned to the client application.

If the statement is contained within the source code for a procedure, WITH RETURN TO CALLER specifies that the cursor can be used as a result set cursor. A result set cursor is used when the result table of a cursor is to be returned from a procedure. Specifying TO CALLER is optional.

In other cases, the clause is ignored and the cursor cannot be used as a result set cursor.

TO CLIENT

Specifies that the cursor can return a result set to the client application. This cursor is invisible to any intermediate nested procedures. If a function or trigger calls the procedure (either directly or indirectly), the result set cannot be returned to the client and the cursor will be closed after the procedure finishes.

rowset-positioning

Specifies whether multiple rows of data can be accessed as a rowset on a single FETCH statement for the cursor. The default is WITHOUT ROWSET POSITIONING.

WITHOUT ROWSET POSITIONING

Specifies that the cursor can be used only with row-positioned FETCH statements. The cursor is to return a single row for each FETCH statement and the FOR *n* ROWS clause cannot be specified on a FETCH statement for this cursor. WITHOUT ROWSET POSITIONING or single row access refers to how data is fetched from the database engine. For remote access, data might be blocked and returned to the client in blocks.

WITH ROWSET POSITIONING

Specifies that the cursor can be used with either row-positioned or rowset-positioned FETCH statements. This cursor can be used to return either a single row or multiple rows, as a rowset, with a single FETCH statement. ROWSET POSITIONING refers to how data is fetched from the database engine. For remote access, if any row qualifies, at least 1 row is returned as a rowset. The size of the rowset depends on the number of rows specified on the FETCH statement and on the number of rows that qualify. Data might be blocked and returned to the client in blocks.

Db2 REXX applications do not support cursors that are declared WITH ROWSET POSITIONING. To allow a cursor for a SELECT statement in a Db2 REXX application to be used with row-positioned or rowset-positioned FETCH statements, specify WITH ROWSET POSITIONING in the attribute string of the PREPARE statement for the SELECT statement.

select-statement

Specifies the result table of the cursor. See [“select-statement” on page 1067](#) for an explanation of *select-statement*.

The *select-statement* must not include parameter markers (except for REXX), but can include references to host variables. In host languages, other than REXX, the declarations of the host variables must precede the DECLARE CURSOR statement in the source program. In REXX, parameter markers must be used in place of host variables and the statement must be prepared.

The USING clause of the OPEN statement can be used to specify host variables that will override the values of the host variables or parameter markers that are specified as part of the statement in the DECLARE CURSOR statement.

The *select-statement* must not contain an SQL data change statement if the cursor is defined as SENSITIVE DYNAMIC or SENSITIVE STATIC.

The *select-statement* must not contain a fullselect that is a VALUES clause.

The outer select list of the *select-statement* of a scrollable cursor must not be an array value.

statement-name

Identifies the prepared *select-statement* that specifies the result table of the cursor whenever the cursor is opened. The *statement-name* must not be identical to a statement name specified in

another DECLARE CURSOR statement of the source program. For an explanation of prepared SELECT statements, see [“PREPARE statement” on page 2042](#).

The prepared *select-statement* must not contain an SQL data change statement if the cursor is defined as SENSITIVE DYNAMIC or SENSITIVE STATIC.

Notes for DECLARE CURSOR

A cursor in the open state designates a result table and a position relative to the rows of that table. The table is the result table specified by the SELECT statement of the cursor.

Read-only cursors:

If the result table is *read-only*, the cursor is *read-only*. The cursor that references a view with instead of triggers are read-only since positioned UPDATE and positioned DELETE statements are not allowed using those cursors. The result table is *read-only* if one or more of the following statements is true about the *select-statement* of the cursor:

- The first FROM clause identifies or contains any of the following:
 - More than one table or view
 - A catalog table with no updatable columns
 - A read-only view
 - A nested table expression
 - A table function
 - A system-maintained materialized query table
 - A single table that is a system-period temporal table, and a period specification for SYSTEM_TIME is used
 - A single view that directly or indirectly references a system-period temporal table in the FROM clause of the outer fullselect of the view definition, and a period specification for SYSTEM_TIME is used
- The first SELECT clause specifies the keyword DISTINCT, contains an aggregate function, or uses both
- It contains an SQL data change statement
- The outer subselect contains a GROUP BY clause, a HAVING clause, or both clauses
- It contains a subquery such that the base object of the outer subselect, and of the subquery, is the same table
- Any of the following operators or clauses are specified:
 - A set operator
 - An ORDER BY clause (except when the cursor is declared as SENSITIVE STATIC scrollable)
 - A FOR READ ONLY clause
- It is executed with isolation level UR and a FOR UPDATE clause is not specified.
- It is a VALUES clause.

If the result table is not read-only, the cursor can be used to update or delete the underlying rows of the result table.

Referencing columns that will be updated:

If a cursor uses FETCH statements to retrieve columns that will be updated later, specify FOR UPDATE OF when you select the columns. Then specify WHERE CURRENT OF in the subsequent UPDATE or DELETE statements. These clauses prevent Db2 from selecting access through an index on the columns that are being updated, which might otherwise cause Db2 to read the same row more than once.

For more information, see [Updating previously retrieved data \(Db2 Application programming and SQL\)](#).

Tables for which row or column access controls are enforced:

The *select-statement* of the cursor can reference a table for which row or column access controls are enforced. The row or column access controls do not effect the determination of whether the cursor is read-only and do not effect the cursor sensitivity.

Work file database requirement for static scrollable cursors:

To use a static scrollable cursor, you must first create a work file database and at least one table space with a 32KB page size in this database because a static scrollable cursor requires a temporary table for its result table while the cursor is open. Db2 chooses a table space to use for the temporary result table. Dynamic scrollable cursors do not require a declared temporary table.

For static scrollable cursor declarations that contain empty strings, Db2 assigns one byte in the temporary table space for each empty string. The following example shows a scrollable cursor declaration with an empty string:

```
EXEC SQL DECLARE CSROWSTAT SENSITIVE STATIC SCROLL CURSOR
WITH ROWSET POSITIONING WITH HOLD FOR
SELECT ID1, ''
FROM TB;
```

Cursors in COBOL and Fortran programs:

In COBOL and Fortran source programs, the DECLARE CURSOR statement must precede all statements that explicitly refer to the cursor by name. This rule does not necessarily apply to the other host languages because the precompiler provides a two-pass option for these languages. This rule applies to other host languages if the two-pass option is not used.

Cursors in REXX:

If host variables are used in a DECLARE CURSOR statement within a REXX procedure, the DECLARE CURSOR statement must be the object of a PREPARE and EXECUTE.

Scope of a cursor:

The scope of *cursor-name* is the source program in which it is defined; that is, the application program submitted to the precompiler. Thus, you can only refer to a cursor by statements that are precompiled with the cursor declaration. For example, a COBOL program called from another program cannot use a cursor that was opened by the calling program. Furthermore, a cursor defined in a Fortran subprogram can only be referred to in that subprogram. Cursors that specify WITH RETURN in a procedure and are left open are returned as result sets.

Although the scope of a cursor is the program in which it is declared, each package (or DBRM of a plan) created from the program includes a separate instance of the cursor, and more than one instance of the cursor can be used in the same execution of the program. For example, assume a program is precompiled with the CONNECT(2) option and its DBRM is used to create a package at location X and a package at location Y. The program contains the following SQL statements:

```
DECLARE C CURSOR FOR ...
CONNECT TO X
OPEN C
FETCH C INTO ...
CONNECT TO Y
OPEN C
FETCH C INTO ...
```

The second OPEN C statement does not cause an error because it refers to a different instance of cursor C. The same notion applies to a single location if the packages are in different collections.

A SELECT statement is evaluated at the time the cursor is opened. If the same cursor is opened, closed, and then opened again, the results can be different. If the SELECT statement of the cursor contains CURRENT DATE, CURRENT TIME or CURRENT TIMESTAMP, all references to these special registers yields the same respective datetime value on each FETCH operation. The value is determined when the cursor is opened. Multiple cursors using the same SELECT statement can be opened concurrently. They are each considered independent activities.

Blocking of data:

To process data more efficiently, Db2 might block data for read-only cursors. If a cursor is not going to be used in a positioned UPDATE or positioned DELETE statement, define the cursor as FOR READ ONLY.

Positioned deletes and isolation level UR:

Specify FOR UPDATE if you want to use the cursor for a positioned DELETE and the isolation level is UR because of a BIND option. In this case, the isolation level is CS.

Returning a result set from a stored procedure:

A cursor that is declared in a stored procedure returns a result set when all of the following conditions are true:

- The cursor is declared with the WITH RETURN option. In a distributed environment, blocks of each result set of the cursor's data are returned with the CALL statement reply.
- The cursor is left open after exiting from the stored procedure. A cursor declared with the SCROLL option must be left positioned *before* the first row before exiting from the stored procedure.
- The cursor is declared with the WITH HOLD option if the stored procedure is defined to commit on return.

The result set is the set of all rows after the current position of the cursor after exiting the stored procedure. The result set is assumed to be read-only. If that same procedure is invoked again, open result set cursors for a stored procedure at a given site are automatically closed by the database management system.

Scrollable cursors specified with user-defined functions:

A row can be fetched more than once with a scrollable cursor. Therefore, if a scrollable cursor is defined with a function that is not deterministic in the select list of the cursor, a row can be fetched multiple times with different results for each fetch. (However, the value of a function that is not deterministic in the WHERE clause of a scrollable cursor is captured when the cursor is opened and remains unchanged until the cursor is closed.) Similarly, if a scrollable cursor is defined with a user-defined function with external action, the action is executed with every fetch.

Multiple instances of a cursor that is defined with RETURN TO CLIENT:

If the cursor is declared in a native SQL procedure, a cursor that is declared as WITH RETURN TO CLIENT can be opened even when a cursor with the same name is already in the open state. In this case, the already open cursor becomes a result set cursor and is no longer accessible by using its cursor name. A new cursor is opened and becomes accessible by using the cursor name. When a CLOSE statement is issued, the last instance of the cursor will be closed. Closing the new cursor does not make the cursor that was previously accessible by that name accessible by the cursor name again. Cursors that become result set cursors in this way cannot be accessed at the server and can be processed only at the client.

Examples for DECLARE CURSOR

The statements in the following examples are assumed to be in PL/I programs.

Example 1

Declare C1 as the cursor of a query to retrieve data from the table DSN8C10.DEPT. The query itself appears in the DECLARE CURSOR statement.

```
EXEC SQL DECLARE C1 CURSOR FOR
  SELECT DEPTNO, DEPTNAME, MGRNO
  FROM DSN8C10.DEPT
  WHERE ADMRDEPT = 'A00';
```

Example 2

Declare C1 as the cursor of a query to retrieve data from the table DSN8810.DEPT. Assume that the data will be updated later with a searched update and should be locked when the query executes. The query itself appears in the DECLARE CURSOR statement.

```
EXEC SQL DECLARE C1 CURSOR FOR
SELECT DEPTNO, DEPTNAME, MGRNO
FROM DSN8C10.DEPT
WHERE ADMRDEPT = 'A00'
FOR READ ONLY WITH RS USE AND KEEP EXCLUSIVE LOCKS;
```

Example 3

Declare C2 as the cursor for a statement named STMT2.

```
EXEC SQL DECLARE C2 CURSOR FOR STMT2;
```

Example 4

Declare C3 as the cursor for a query to be used in positioned updates of the table DSN8C10.EMP. Allow the completed updates to be committed from time to time without closing the cursor.

```
EXEC SQL DECLARE C3 CURSOR WITH HOLD FOR
SELECT * FROM DSN8C10.EMP
FOR UPDATE OF WORKDEPT, PHONENO, JOB, EDLEVEL, SALARY;
```

Instead of specifying which columns should be updated, you could use a FOR UPDATE clause without the names of the columns to indicate that all updatable columns are updated.

Example 5

In stored procedure SP1, declare C4 as the cursor for a query of the table DSN8C10.PROJ. Enable the cursor to return a result set to the caller of SP1, which performs a commit on return.

```
EXEC SQL DECLARE C4 CURSOR WITH HOLD WITH RETURN FOR
SELECT PROJNO, PROJNAME
FROM DSN8C10.PROJ
WHERE DEPTNO = 'A01';
```

Example 6

In the following example, the DECLARE CURSOR statement associates the cursor name C5 with the results of the SELECT and specifies that the cursor is scrollable. C5 allows positioned updates and deletes because the result table can be updated.

```
EXEC SQL DECLARE C5 SENSITIVE STATIC SCROLL CURSOR FOR
SELECT DEPTNO, DEPTNAME, MGRNO
FROM DSN8C10.DEPT
WHERE ADMRDEPT = 'A00';
```

Example 7

In the following example, the DECLARE CURSOR statement associates the cursor name C6 with the results of the SELECT and specifies that the cursor is scrollable.

```
EXEC SQL DECLARE C6 INSENSITIVE SCROLL CURSOR FOR
SELECT DEPTNO, DEPTNAME, MGRNO
FROM DSN8C10.DEPT
WHERE DEPTNO;
```

Example 8

The following example illustrates how an application program might use dynamic scrollable cursors: First create and populate a table.

```
CREATE TABLE ORDER
(ORDERNUM INTEGER,
CUSTNUM INTEGER,
CUSTNAME VARCHAR(20),
ORDERDATE CHAR(8),
ORDERAMT DECIMAL(8,3),
COMMENTS VARCHAR(20));
```

Populate the table by inserting or loading about 500 rows.

```
EXEC SQL DECLARE CURSOR ORDERSCROLL
SENSITIVE DYNAMIC SCROLL FOR
SELECT ORDERNUM, CUSTNAME, ORDERAMT, ORDERDATE FROM ORDER
WHERE ORDERAMT > 1000
FOR UPDATE OF COMMENTS;
```

Open the scrollable cursor.

```
OPEN CURSOR ORDERSCROLL;
```

Fetch forward from the scrollable cursor.

```
-- Loop-to-fill-screen
-- do 10 times
  FETCH FROM ORDERSCROLL INTO :HV1, :HV2, :HV3, :HV4;
-- end
```

Fetch RELATIVE from the scrollable cursor.

```
-- Skip-forward-100-rows
  FETCH RELATIVE +100
  FROM ORDERSCROLL INTO :HV1, :HV2, :HV3, :HV4;
```

```
-- Skip-backward-50-rows
  FETCH RELATIVE -50
  FROM ORDERSCROLL INTO :HV1, :HV2, :HV3, :HV4;
```

Fetch ABSOLUTE from the scrollable cursor.

```
-- Re-read-the-third-row
  FETCH ABSOLUTE +3
  FROM ORDERSCROLL INTO :HV1, :HV2, :HV3, :HV4;
```

Fetch RELATIVE from scrollable cursor.

```
-- Read-the-third-row-from current position
  FETCH SENSITIVE RELATIVE +3
  FROM ORDERSCROLL INTO :HV1, :HV2, :HV3, :HV4;
```

Do a positioned update through the scrollable cursor.

```
-- Update-the-current-row
  UPDATE ORDER SET COMMENTS = "Expedite"
  WHERE CURRENT OF ORDERSCROLL;
```

Close the scrollable cursor.

```
CLOSE CURSOR ORDERSCROLL;
```

Example 9

Declare C1 as the cursor of a query to retrieve a rowset from the table DEPT. The prepared statement is MYCURSOR.

```
EXEC SQL DECLARE C1 CURSOR
WITH ROWSET POSITIONING FOR MYCURSOR;
```

Related tasks

[Retrieving a set of rows by using a cursor \(Db2 Application programming and SQL\)](#)

[Using scrollable cursors efficiently \(Db2 Performance\)](#)

DECLARE GLOBAL TEMPORARY TABLE statement

The DECLARE GLOBAL TEMPORARY TABLE statement defines a declared temporary table for the current application process. The declared temporary table resides in the work file database and its description does not appear in the system catalog. It is not persistent and cannot be shared with other application processes. Each application process that defines a declared temporary table of the same name has its own unique description and instance of the temporary table. When the application process terminates, the temporary table is dropped.

Invocation for DECLARE GLOBAL TEMPORARY TABLE

This statement can be embedded in an application program or issued interactively. It is an executable statement that can be dynamically prepared.

Authorization for DECLARE GLOBAL TEMPORARY TABLE

None are required, unless the LIKE clause or AS *fullselect* is specified. In those cases, additional privileges might be required.

PUBLIC implicitly has the following privileges without GRANT authority for declared temporary tables:

- The CREATETAB privilege to define a declared temporary table in the database that is defined AS WORKFILE, which is the database for declared temporary tables.
- The USE privilege to use the table spaces in the database that is defined as WORKFILE.
- All table privileges on the table and authority to drop the table. (Table privileges for a declared temporary table cannot be granted or revoked.)

These implicit privileges are not recorded in the Db2 catalog and cannot be revoked.

Syntax for DECLARE GLOBAL TEMPORARY TABLE

► DECLARE GLOBAL TEMPORARY TABLE — *table-name* ►

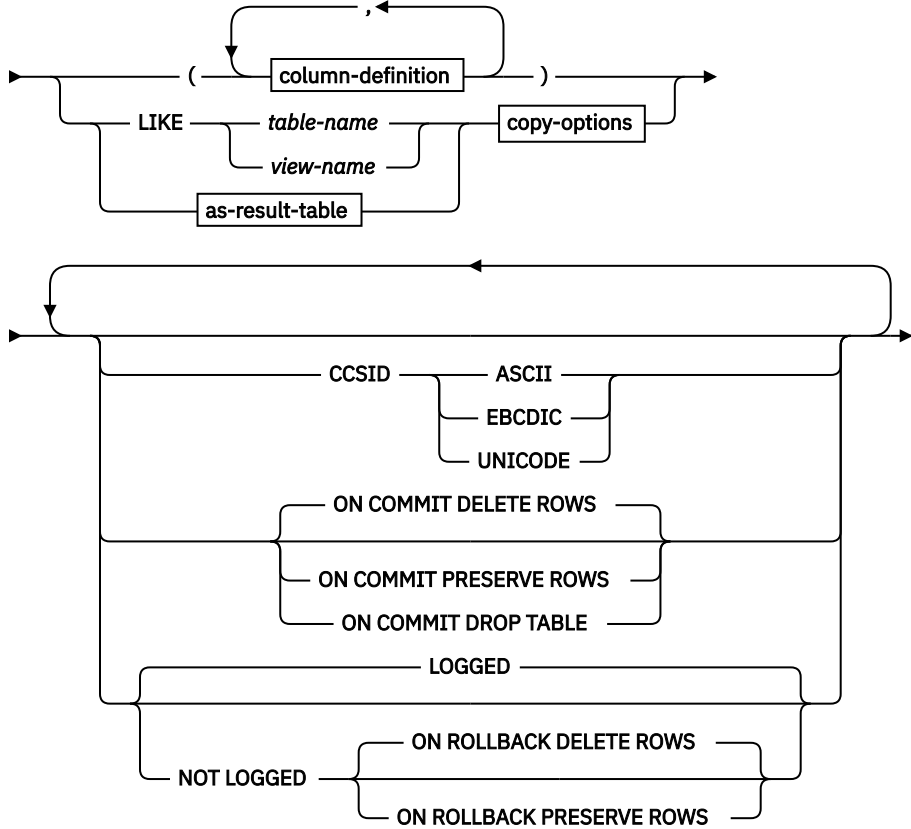

Notes:

¹ The same clause must not be specified more than one time.

column-definition:

► *column-name* — *data-type* ¹ ►

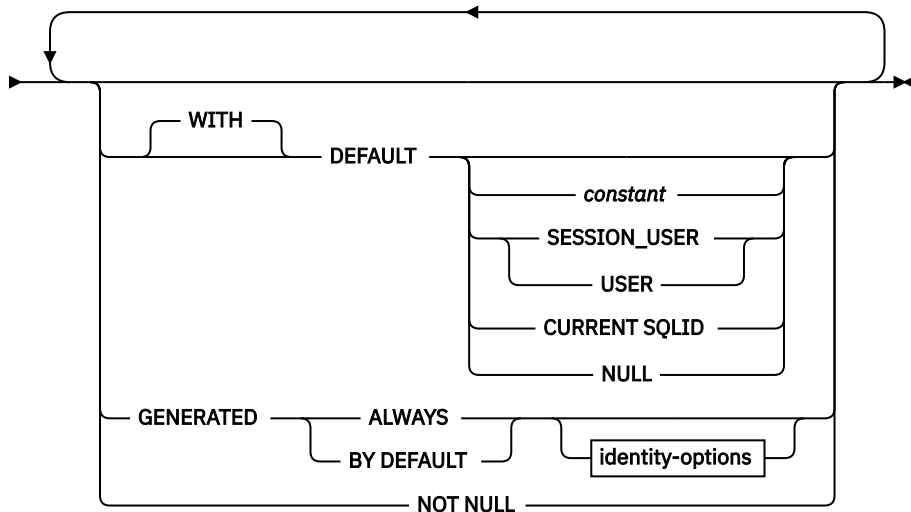

Notes:

¹ The same clause must not be specified more than once.

data-type:

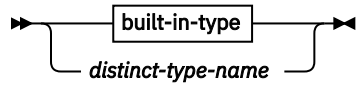

built-in-type:

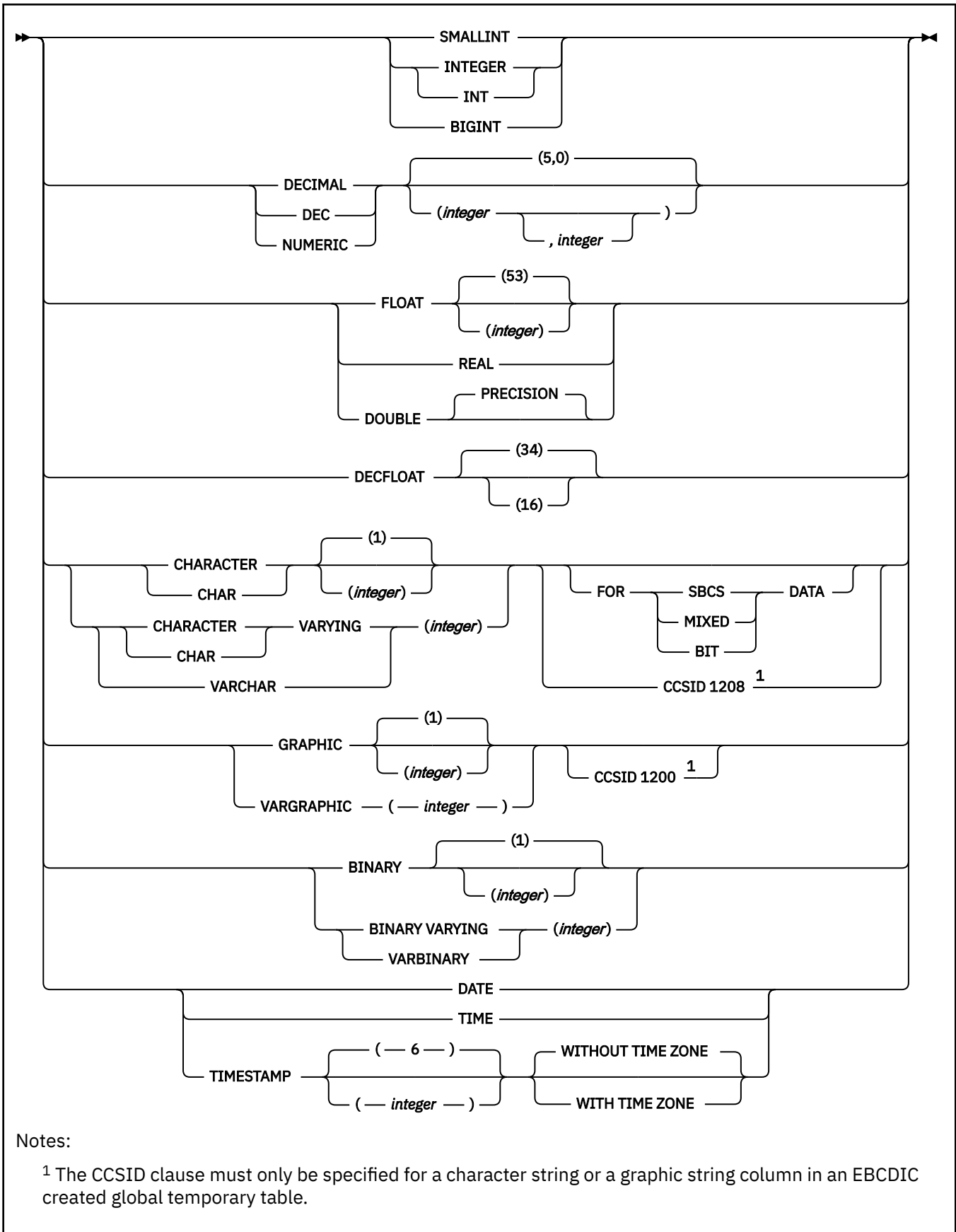

as-result-table:

► AS — (*fullselect*) — WITH NO DATA ◄

copy-options:

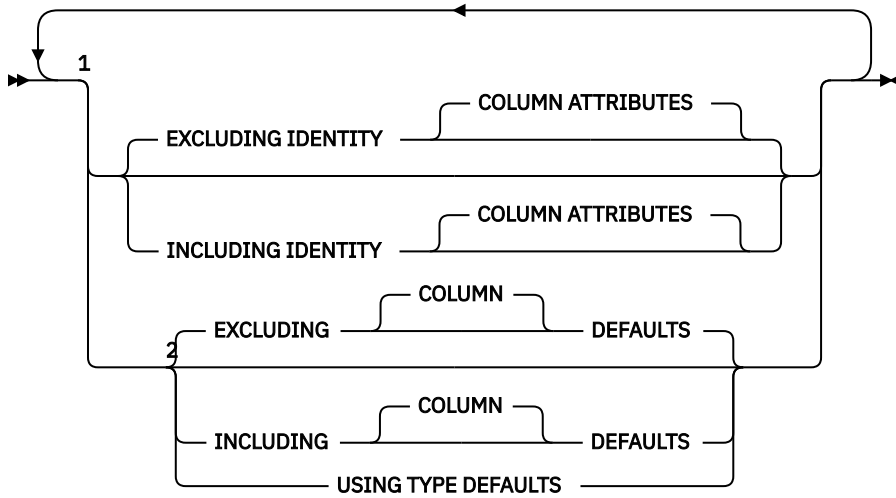

Notes:

- ¹ These clauses can be specified in any order and must not be specified more than one time.
- ² EXCLUDING COLUMN DEFAULTS, INCLUDING COLUMN DEFAULTS, and USING TYPE DEFAULTS must not be specified with the LIKE clause.

identity-options:

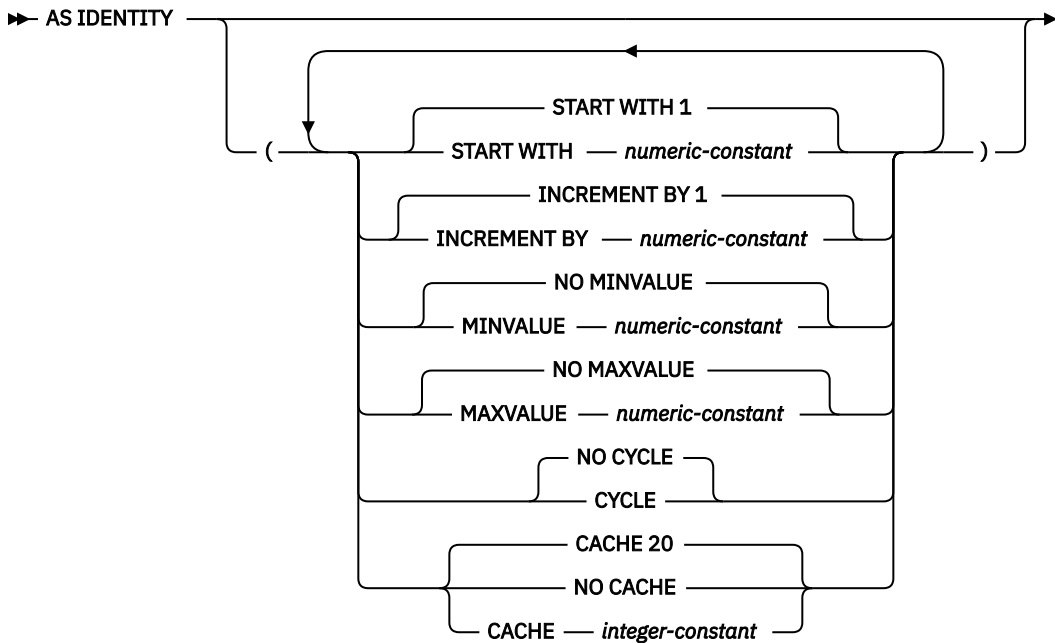

Notes:

- ¹ Separator commas can be specified between the attributes when an identity column is defined

Description for DECLARE GLOBAL TEMPORARY TABLE

table-name

Names the temporary table. The qualifier, if specified explicitly, must be SESSION. If the qualifier is not specified, it is implicitly defined to be SESSION.

If a table, view, synonym, or alias already exists with the same name and an implicit or explicit qualifier of SESSION:

- The declared temporary table is still defined with SESSION.*table-name*. An error is not issued because the resolution of a declared temporary table name does not include the persistent and shared names in the Db2 catalog tables.
- Any references to SESSION.*table-name* will resolve to the declared temporary table rather than to any existing SESSION.*table-name* whose definition is persistent and is in the Db2 catalog tables.

column-definition

Defines the attributes of a column for each instance of the table. The number of columns defined must not exceed 750. The maximum record size must not exceed 32683 bytes. The maximum row size must not exceed 32675 bytes (8 bytes less than the maximum record size).

column-name

Names the column. The name must not be qualified and must not be the same as the name of another column in the table.

data-type

Specifies the data type of the column. The data type can be any built-in data type that can be specified for the CREATE TABLE statement except for a LOB (BLOB, CLOB, and DBCLOB), ROWID, or XML type. The FOR *subtype* DATA clause can be specified as part of *data-type*. For more information on the data types and the rules that apply to them, see [built-in-type](#).

DEFAULT

Specifies a default value for the column. This clause must not be specified more than once in the same *column-definition*.

Omission of NOT NULL and DEFAULT from a *column-definition* is an implicit specification of DEFAULT NULL.

If DEFAULT is specified without a value after it, the default value of the column depends on the data type of the column, as follows:

Data type

Default value

Numeric

0

Fixed-length character string

A string of blanks

Fixed-length graphic string

A string of blanks

Fixed-length binary string

Hexadecimal zeros

Varying-length string

A string of length 0

Date

CURRENT DATE

Time

CURRENT TIME

Timestamp

CURRENT TIMESTAMP(*p*) where *p* is the corresponding timestamp precision.

Timestamp with time zone

CURRENT TIMESTAMP(*p*) WITH TIME ZONE where *p* is the corresponding timestamp precision.

A default value other than the one that is listed above can be specified in one of the following forms:

constant

Specifies a constant as the default value for the column. The value of the constant must conform to the rules for assigning that value to the column. A hexadecimal graphic string constant (GX) cannot be specified.

SESSION_USER or USER

Specifies the value of the SESSION_USER (USER) special register at the time of an insert or update operation or LOAD as the default value for the column. The data type of the column must be a character string with a length attribute greater than or equal to the length attribute of the SESSION_USER special register.

CURRENT SQLID

Specifies the value of the SQL authorization ID of the process at the time of an SQL data change statement or LOAD as the default value for the column. The data type of the column must be a character string with a length attribute greater than or equal to the length attribute of the CURRENT SQLID special register.

NULL

Specifies null as the default value for the column. If NOT NULL was specified, DEFAULT NULL must not be specified within the same *column-definition*.

GENERATED

Specifies that Db2 generates values for the column. GENERATED must be specified if the column is to be considered an IDENTITY column. If DEFAULT is specified for the column for an update operation, Db2 generates a value for both GENERATED ALWAYS and GENERATED BY DEFAULT.

ALWAYS

Specifies that Db2 always generates a value for the column when a row is inserted into the table.

BY DEFAULT

Specifies that Db2 generates a value for the column when a row is inserted into the table unless a value is specified. BY DEFAULT is the recommended value only when you are using data propagation.

Defining a column as GENERATED BY DEFAULT does not necessarily guarantee the uniqueness of the values. To ensure uniqueness of the values, define a unique, single-column index on the column.

AS IDENTITY

Specifies that the column is an identity column for the table. A table can have only one identity column. AS IDENTITY can be specified only if the data type for the column is an exact numeric type with a scale of zero (SMALLINT, INTEGER, BIGINT, DECIMAL with a scale of zero).

An identity column is implicitly NOT NULL. An identity column cannot have a DEFAULT clause. For the descriptions of the identity attributes, see the description of the AS IDENTITY clause in [“CREATE TABLE statement”](#) on page 1650.

NOT NULL

Specifies that the column cannot contain nulls. Omission of NOT NULL indicates that the column can contain nulls.

LIKE *table-name* or *view-name*

Specifies that the columns of the table have the same name, data type, and nullability attributes as the columns of the identified table or view. If a table is identified, the column default attributes are also defined by that table. If row permissions or column access control is enforced for the table specified by *table-name*, row and column access controls are not inherited by the new table. The name specified must identify a table, view, synonym, or alias that exists at the current server. The identified table must not be an auxiliary table or an accelerator-only table.

The privilege set must include the SELECT privilege on the identified table or view.

This clause is similar to the LIKE clause on CREATE TABLE, but it has the following differences:

- If LIKE results in a column having a LOB data type, a ROWID data type, or distinct type, the DECLARE GLOBAL TEMPORARY TABLE statement fails.
- In addition to these data type restrictions, if any column has any other attribute value that is not allowed in a declared temporary table, that attribute value is ignored. The corresponding column in the new temporary table has the default value for that attribute unless otherwise indicated.

When the identified object is a table, the column name, data type, nullability, and default attributes are determined from the columns of the specified table; any identity column attributes are inherited only if the INCLUDING IDENTITY COLUMN ATTRIBUTES clause is specified.

as-result-table

Specifies that the table definition is based on the column definitions from the result of a query expression.

The behavior of these column attributes is controlled with the INCLUDING or USING TYPE DEFAULTS clauses, which are defined below.

AS (fullselect)

Specifies an implicit definition of *n* columns for the declared global temporary table, where *n* is the number of columns that would result from the *fullselect*. The columns of the new table are defined by the columns that result from the *fullselect*. Every select list element must have a unique name. The AS clause can be used in the *select-clause* to provide unique names. The implicit definition includes the column name, data type, and nullability characteristic of each of the result columns of *fullselect*. A column of the new table that corresponds to an implicitly hidden column of a base table referenced in the *fullselect* is not considered hidden in the new table. Row and column access controls that are enforced on the base table are not inherited by the new table.

The result table of the *fullselect* must not contain a column that has a LOB data type, a ROWID data type, an XML data type or a distinct type.

If *fullselect* results in other column attributes that are not applicable for a declared temporary table, those attributes are ignored in the implicit definition for the declared temporary table.

If *fullselect* results in a row change timestamp column, the corresponding column of the new table inherits only the data type of the row change timestamp column. The new column is not considered as a generated column.

The *fullselect* must not refer to variables or include parameter markers (question marks), but can refer to global variables. The outermost SELECT list of the outermost *fullselect* must not reference data that is encoded with different encoding schemes, unless that data is from EBCDIC and Unicode columns in an EBCDIC table. The outermost SELECT list of the outermost *fullselect* must not result in a column that is an array.

WITH NO DATA

Specifies that the *fullselect* is not executed. You can use the INSERT INTO statement with the same *fullselect* specified in the AS clause to populate the declared temporary table with the set of rows from the result table of the *fullselect*.

copy-options

Specifies whether identity column attributes and column defaults are inherited from the definition of the source of the result table.

EXCLUDING IDENTITY COLUMN ATTRIBUTES or INCLUDING IDENTITY COLUMN ATTRIBUTES

Specifies whether identity column attributes are inherited from the columns resulting from the *fullselect*, *table-name*, or *view-name*.

EXCLUDING IDENTITY COLUMN ATTRIBUTES

Specifies that the table does not inherit the identity attributes of the columns resulting from the *fullselect*, *table-name*, or *view-name*.

INCLUDING IDENTITY COLUMN ATTRIBUTES

Specifies that the table inherits the identity attributes, if any, of the columns resulting from the *fullselect* or *table-name*. In general, the identity attributes are copied if the element of the

corresponding column in the table or *fullselect* is the name of a table column that directly or indirectly maps to the name of a base table column that is an identity column.

If the INCLUDING IDENTITY COLUMN ATTRIBUTES clause is specified with the AS fullselect clause, the columns of the new table do not inherit the identity attribute in the following cases:

- The select list of the *fullselect* includes multiple instances of an identity column name (that is, selecting the same column more than once).
- The select list of the *fullselect* includes multiple identity columns (that is, it involves a join).
- The identity column is included in an expression in the select list.
- The *fullselect* includes a set operation.

If INCLUDING IDENTITY COLUMN ATTRIBUTES is not specified, the new table will not have an identity column.

If the LIKE clause identifies a view, INCLUDING IDENTITY COLUMN ATTRIBUTES must not be specified.

EXCLUDING COLUMN DEFAULTS, INCLUDING COLUMN DEFAULTS, or USING TYPE DEFAULTS

Specifies whether the table inherits the default values of the columns of the fullselect.

EXCLUDING COLUMN DEFAULTS, INCLUDING COLUMN DEFAULTS, and USING TYPE DEFAULTS must not be specified if the LIKE clause is specified.

EXCLUDING COLUMN DEFAULTS

Specifies that the table does not inherit the default values of the columns of the fullselect. The default values of the column of the new table are either null or there are no default values. If the column can be null, the default is the null value. If the column cannot be null, there is no default value, and an error occurs if a value is not provided for a column on an insert operation for the new table.

INCLUDING COLUMN DEFAULTS

Specifies that the table inherits the default values of the columns of the fullselect. A default value is the value that is assigned to the column when a value is not specified on an insert operation or LOAD. Columns resulting from the fullselect that are not updatable will not have a default defined in the corresponding column of the created table.

USING TYPE DEFAULTS

Specifies that the default values for the declared temporary table depend on the data type of the columns that result from *fullselect*, as follows:

Data type

Default value

Numeric

0

Fixed-length character string

Blanks

Fixed-length graphic string

Blanks

Fixed-length binary string

Hexadecimal zeros

Varying-length string

A string of length 0

Date

CURRENT DATE

Time

CURRENT TIME

Timestamp

CURRENT TIMESTAMP(*p*) where *p* is the corresponding timestamp precision.

Timestamp(*integer*) with time zone

CURRENT TIMESTAMP(*p*) WITH TIME ZONE where *p* is the corresponding timestamp precision.

CCSID encoding-scheme

Specifies the encoding scheme for string data that is stored in the table. For declared temporary tables, the encoding scheme for the data cannot be specified for the table space or database, and all data in one table space or the database need not use the same encoding scheme. Because there can be only one work file database for all declared temporary tables for each Db2 member, there can be a mixture of encoding schemes in both the database and each table space.

The CCSID clause can be specified for the declared temporary table, or for individual columns in the declared temporary table. If a CCSID clause is specified for the table, that CCSID specifies the encoding scheme for the table, regardless of whether the LIKE clause is also specified. If a CCSID clause is not specified for the table, the encoding scheme for the table is EBCDIC.

If a CCSID clause is specified for a column, the encoding scheme for the declared temporary table must be EBCDIC. If a CCSID clause is not specified for a column, and the LIKE clause is not specified for the table, the CCSID of the column is the same as the CCSID of the table. If the LIKE clause is specified, and the source table that is specified in the LIKE clause is an EBCDIC table with Unicode columns, the columns in the declared temporary table that correspond to the Unicode columns in the source table are also Unicode.

ASCII

Specifies that the data is encoded by using the ASCII CCSIDs of the server.

EBCDIC

Specifies that the data is encoded by using the EBCDIC CCSIDs of the server.

UNICODE

Specifies that the data is encoded by using the UNICODE CCSIDs of the server.

An error occurs if the CCSIDs for the encoding scheme have not been defined. Usually, each encoding scheme requires only a single CCSID. Additional CCSIDs are needed when mixed, graphic, or UNICODE data is used.

ON COMMIT

Specifies what happens to the table for a commit operation. The default is ON COMMIT DELETE ROWS.

DELETE ROWS

Specifies that all of the rows of the table are deleted if there is no open cursor that is defined as WITH HOLD that references the table.

PRESERVE ROWS

Specifies that all of the rows of the table are preserved. Thread reuse capability is not available to any application process or thread that contains, at its most recent commit, an active declared temporary table that was defined with the ON COMMIT PRESERVE ROWS clause.

DROP TABLE

Specifies that the table is implicitly dropped at commit if there is no open cursor that is defined as WITH HOLD that references the table. If there is an open cursor defined as WITH HOLD on the table at commit, the rows are preserved.

LOGGED or NOT LOGGED

Specifies whether operations for the table are to be logged. This option also applies to any indexes that are associated with the table. Indexes inherit the logging attribute from their associated tables.

LOGGED

Specifies that insert, update, or delete operations for the declared temporary table are logged. Create and drop actions for the table are also logged. This is the default option.

NOT LOGGED

Specifies that insert, update, or delete operations for the declared temporary table are not logged. However, create and drop actions for the table are logged.

ON ROLLBACK DELETE ROWS

Specifies that when a ROLLBACK or ROLLBACK TO SAVEPOINT statement is issued, all rows of the global temporary table are deleted. This is the default.

ON ROLLBACK PRESERVE ROWS

Specifies that when a ROLLBACK or ROLLBACK TO SAVEPOINT statement is issued, all rows of the global temporary table are preserved.

If a ROLLBACK or ROLLBACK TO SAVEPOINT statement is issued, the following actions occur for tables that were created or dropped:

- If the table was created within the unit of work or savepoint, the table is dropped.
- If the table was dropped within the unit of work or savepoint, the table is re-created without any data.

For statements that insert multiple rows, the ATOMIC and NOT ATOMIC CONTINUE ON SQLEXCEPTION options of the INSERT statement determine the result of an error. If ATOMIC is specified, an error during insertion causes all rows in the global temporary table to be deleted. If NOT ATOMIC CONTINUE ON SQLEXCEPTION is specified, an error during insertion causes all rows in the table to be deleted, but the next insert is processed. At the end of the insert, the table includes only the rows that were inserted after the last error.

Restriction: In CREATE TABLESPACE and ALTER TABLESPACE statements, LOG YES and LOG NO can be used as syntax alternatives for LOGGED and NOT LOGGED, respectively. These syntax alternatives cannot be used in a DECLARE GLOBAL TEMPORARY TABLE statement.

Notes for DECLARE GLOBAL TEMPORARY TABLE

Instantiation, scope, and termination

For the following explanations, P denotes an application process, and T is a declared temporary table executed in P:

- An empty instance of T is created when a DECLARE GLOBAL TEMPORARY TABLE statement is executed in P.
- Any SQL statement in P can reference T, and any of those references to T in P is a reference to that same instance of T. ()

If a DECLARE GLOBAL TEMPORARY statement is specified within an SQL PL compound statement, the scope of the declared temporary table is the application process and not just the compound statement. A declared temporary table cannot be defined multiple times by the same name in other compound statements in that application process, unless the table has been dropped explicitly.

- If T was declared at a remote server, the reference to T must use the same Db2 connection that was used to declare T and that connection must not have been terminated after T was declared. When the connection to the database server at which T was declared terminates, T is dropped.
- If T was defined with the ON COMMIT DELETE ROWS clause specified implicitly or explicitly, when a commit operation terminates a unit of work in P and there is no open WITH HOLD cursor in P that is dependent on T, the commit deletes all rows from T.
- If T is defined with the ON COMMIT DROP TABLE clause, when a commit operation terminates a unit of work in P and no program in P has a WITH HOLD cursor open that is dependent on T, the commit includes the operation DROP TABLE T.
- When a rollback operation terminates a unit of work or savepoint in P, and that unit of work or savepoint includes the declaration of SESSION.T, the changes to table T are undone.

When a rollback operation terminates a unit of work or savepoint in P, and that unit of work or savepoint includes the declaration of SESSION.T, the rollback drops table T.

When a rollback operation terminates a unit of work or savepoint in P, and that unit of work or savepoint includes the drop of the declaration of declared temporary table SESSION.T, the rollback undoes the drop of table T.

- When the application process that declared T terminates, T is dropped.
- When a rollback operation terminates a unit of work or a savepoint in P, and that unit of work or savepoint includes a modification to SESSION.T the following actions occur:
 - If NOT LOGGED was specified, all rows from SESSION.T are deleted unless ON ROLLBACK PRESERVE ROWS was also specified.
 - If NOT LOGGED was not specified, the changes to table T are undone.
- If NOT LOGGED was specified and an INSERT, UPDATE or DELETE statement fails during execution (not a compilation error), all rows from SESSION.T are deleted.
- When a rollback operation terminates a unit of work or a savepoint in P, and that unit of work or savepoint includes the declaration of SESSION.T, the rollback includes the operation DROP SESSION.T.
- When a rollback operation terminates a unit of work or a savepoint in P, and that unit of work or savepoint includes the drop of a declared temporary table SESSION.T, the rollback undoes the drop of the table. If NOT LOGGED was specified, the table is also emptied.
- When the application process that declared T terminates or disconnects from the database, T is dropped and its instantiated rows are destroyed.

Privileges

When a declared temporary table is defined, PUBLIC is implicitly granted all table privileges on the table and authority to drop the table. These implicit privileges are not recorded in the Db2 catalog and cannot be revoked. This enables any SQL statement in the application process to reference a declared temporary table that has already been defined in that application process.

Referring to a declared temporary table in other SQL statements

Many SQL statements support declared temporary tables. To refer to a declared temporary table in an SQL statement other than DECLARE GLOBAL TEMPORARY TABLE, you must qualify the table name with SESSION. You can either specify SESSION explicitly in the table name or use the QUALIFIER bind option to specify SESSION as the qualifier for all SQL statements in the plan or package.

If you use SESSION as the qualifier for a table name but the application process does not include a DECLARE GLOBAL TEMPORARY TABLE statement for the table name, Db2 assumes that you are not referring to a declared temporary table. Db2 resolves such table references to a table whose definition is persistent and appears in the Db2 catalog tables.

With the exception of the DECLARE GLOBAL TEMPORARY TABLE statement, any static SQL statement that references a declared temporary table is incrementally bound at run time. This is because the definition of the declared temporary table does not exist until the DECLARE GLOBAL TEMPORARY statement is executed in the application process that contains those SQL statements and the definition does not persist when the application process finishes running.

When a plan or package is bound, any static SQL statement (other than the DECLARE GLOBAL TEMPORARY TABLE statement) that references a *table-name* that is qualified by SESSION, regardless of whether the reference is for a declared temporary table, is not completely bound. However, the bind of the plan or package succeeds if there are no other errors. No object dependencies, including non-DECLARE GLOBAL TEMPORARY TABLE objects, are recorded in the Db2 catalog for any such statements. These static SQL statements are then incrementally bound at run time when the static SQL statement is issued.

The incremental binds are necessary for the following reasons:

- The definition of the declared temporary table does not exist until the DECLARE GLOBAL TEMPORARY TABLE statement for the table is executed in the same application process that contains those SQL statements. Therefore, Db2 must wait until the plan or package is run to determine if SESSION.*table-name* refers to a base table or a declared temporary table.
- The definition of a declared temporary table does not persist after the table is explicitly dropped (DROP statement), implicitly dropped (ON COMMIT DROP TABLE), or the application process that defined it finishes running. When the application process terminates or is re-used as a reusable

application thread, the instantiated rows of the table are deleted and the definition of the declared temporary table is dropped if it has not already been explicitly or implicitly dropped.

After the plan or package is bound, any static SQL statement that refers to a *table-name* that is qualified by SESSION has a new statement status of M in the Db2 catalog table (STATUS column of SYSIBM.SYSSTMT or SYSIBM.SYSPACKSTMT).

Thread reuse

If a declared temporary table is defined in an application process that is running as a local thread, the application process or local thread that declared the table qualifies for explicit thread reuse if:

- The table was defined with both the default ON COMMIT DELETE ROWS attribute and the NOT LOGGED ON ROLLBACK DELETE ROWS attribute.
- The table was defined with PRESERVE ROWS specified on either the ON COMMIT or NOT LOGGED ON ROLLBACK option and the table was explicitly dropped with the DROP TABLE statement before the thread's commit operation.
- The table was defined with the ON COMMIT DROP TABLE attribute. When a declared temporary table is defined with the ON COMMIT DROP TABLE and a commit occurs, the table is implicitly dropped if there are no open cursors defined with the WITH HOLD option.

When the thread is reused, the declared temporary table is dropped and its rows are destroyed. However, if you do not explicitly or implicitly drop all declared temporary tables before or when your thread performs a commit and the thread becomes idle waiting to be reused, as with all thread reuse situations, the idle thread holds resources and locks. This includes some declared temporary table resources and locks on the table spaces and the database descriptor (DBD) for the work file database. So, instead of using the implicit drop feature of thread reuse to drop your declared temporary tables, it is recommended that you:

- Use the DROP TABLE statement to explicitly drop your declared temporary tables before the thread performs a commit and becomes idle.
- Define the declared temporary tables with ON COMMIT DROP TABLE clause so that the tables are implicitly dropped when a commit occurs.

Explicitly dropping the tables before a commit occurs or having them implicitly dropped when the commit occurs enables you to maximize the use of declared temporary table resources and release locks when multiple threads are using declared temporary table.

Remote threads qualify for thread reuse differently than local threads. If a declared temporary table is defined (with or without ON COMMIT DELETE ROWS) in an application process that is running as a remote or DDF thread (also known as Database Access Thread or DBAT), the remote thread qualifies for thread reuse only when the declared temporary table is explicitly dropped before the thread performs a commit operation. Dropping the declared temporary table enables the remote thread to qualify for the implicit thread reuse that is supported for DDF threads via connection pooling and to become an inactive DBAT (type 1 inactive thread) or an inactive connection (type 2 inactive thread).

Parallelism support

Only I/O and CP parallelism are supported. Any query that involves a declared temporary table is limited to parallel tasks on a single CPC.

Restrictions on the use of declared temporary tables

Declared temporary tables cannot:

- Be specified in referential constraints.
- Be referenced in any SQL statements that are defined in an SQL function body (CREATE FUNCTION or ALTER FUNCTION statements), a trigger body (CREATE TRIGGER statement). If you refer a table name that is qualified with SESSION in a trigger body, Db2 assumes that you are referring to a base table.
- Be referenced in a CREATE INDEX statement unless the schema name of the index is SESSION.

In addition, do not refer to a declared temporary table in any of the following statements.

Statement

ALTER INDEX
ALTER TABLE
COMMENT
CREATE ALIAS
CREATE FUNCTION (TABLE LIKE clause)
CREATE MASK (ON *table-name* clause)
CREATE PERMISSION (ON *table-name* clause)
CREATE PROCEDURE (TABLE LIKE clause)

Statement

CREATE TRIGGER
CREATE VIEW
GRANT (table or view privileges)
LABEL
LOCK TABLE
REFRESH TABLE
RENAME
REVOKE (table or view privileges)

Declared global temporary tables and dynamic statement caching

The Db2 dynamic statement cache feature does not support dynamic SQL statements that reference declared temporary tables, even if the SQL statement also includes references to base or persistent tables. Db2 will not insert such statements into the dynamic statement cache. Instead, these dynamic statements are processed as if statement caching is not in effect. Declared temporary tables are unique and specific to an application process or Db2 thread, cannot be shared across threads, are not described in the Db2 catalog, and do not persist beyond termination of the Db2 thread or application process. These attributes prevent the use of the dynamic statement cache feature where tables and SQL statements are shared across threads or application processes.

Table space requirements in the work file database

Db2 stores all declared temporary tables in the work file database. You cannot define a declared temporary table unless a table space with at least a 32KB page size exists in the work file database.

Alternative syntax and synonyms

To provide compatibility with previous releases, Db2 allows you to specify:

- LONG VARCHAR as a synonym for VARCHAR(*integer*) and LONG VARGRAPHIC as a synonym for VARGRAPHIC(*integer*) when defining the data type of a column.

However, the use of these synonyms is not encouraged because after the statement is processed, Db2 considers a LONG VARCHAR column to be VARCHAR and a LONG VARGRAPHIC column to be VARGRAPHIC.

- DEFINITION ONLY as a synonym for WITH NO DATA.
- TIMEZONE can be specified as an alternative to TIME ZONE.

Examples for DECLARE GLOBAL TEMPORARY TABLE

Example 1

Define a declared temporary table with column definitions for an employee number, salary, commission, and bonus.

```
DECLARE GLOBAL TEMPORARY TABLE SESSION.TEMP_EMP
(EMPNO      CHAR(6)  NOT NULL,
 SALARY     DECIMAL(9, 2),
 BONUS      DECIMAL(9, 2),
 COMM       DECIMAL(9, 2))
CCSID EBCDIC
ON COMMIT PRESERVE ROWS;
```

Example 2

Assume that base table USER1.EMPTAB exists and that it contains three columns, one of which is an identity column. Declare a temporary table that has the same column names and attributes (including identity attributes) as the base table.

```
DECLARE GLOBAL TEMPORARY TABLE TEMPTAB1
LIKE USER1.EMPTAB
```

```
INCLUDING IDENTITY
ON COMMIT PRESERVE ROWS;
```

In the above example, Db2 uses SESSION as the implicit qualifier for TEMPTAB1.

DECLARE STATEMENT statement

The DECLARE STATEMENT statement is used for application program documentation. It declares names that are used to identify prepared SQL statements.

Invocation for DECLARE STATEMENT

This statement can only be embedded in an application program. It is not an executable statement.

Authorization for DECLARE STATEMENT

None required.

Syntax for DECLARE STATEMENT

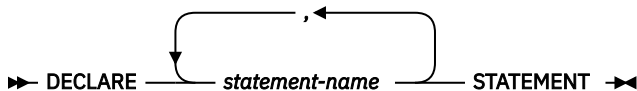

The diagram shows the syntax for the DECLARE STATEMENT statement. It consists of the keyword `DECLARE` followed by a `statement-name` and the keyword `STATEMENT`. A curved arrow points from the `statement-name` back to the `STATEMENT` keyword, indicating that the `statement-name` is used to identify the `STATEMENT`. The entire statement is enclosed in a box with a double-headed arrow on the right side.

Description for DECLARE STATEMENT

statement-name STATEMENT

Lists one or more names that are used in your application program to identify prepared SQL statements.

Example for DECLARE STATEMENT

This example shows the use of the DECLARE STATEMENT statement in a PL/I program.

```
EXEC SQL DECLARE OBJECT_STATEMENT STATEMENT;

EXEC SQL INCLUDE SQLDA;
EXEC SQL DECLARE C1 CURSOR FOR OBJECT_STATEMENT;

( SOURCE STATEMENT IS "SELECT DEPTNO, DEPTNAME,
  MGRNO FROM DSN8C10.DEPT WHERE ADMRDEPT = 'A00' " )

EXEC SQL PREPARE OBJECT_STATEMENT FROM SOURCE_STATEMENT;
EXEC SQL DESCRIBE OBJECT_STATEMENT INTO SQLDA;

/* Examine SQLDA */

EXEC SQL OPEN C1;

DO WHILE (SQLCODE = 0);
  EXEC SQL FETCH C1 USING DESCRIPTOR SQLDA;

/* Print results */

END;

EXEC SQL CLOSE C1;
```

DECLARE TABLE statement

The DECLARE TABLE statement is used for application program documentation. It also provides the precompiler with information used to check your embedded SQL statements. (The DCLGEN subcommand can be used to generate declarations for tables and views described in any accessible Db2 catalog.)

For more information about DCLGEN, see [Declaring table and view definitions \(Db2 Application programming and SQL\)](#) and [DCLGEN \(declarations generator\) subcommand \(DSN\) \(Db2 Commands\)](#).)

Invocation for DECLARE TABLE

This statement can only be embedded in an application program. It is not an executable statement.

Authorization for DECLARE TABLE

None required.

Syntax for DECLARE TABLE

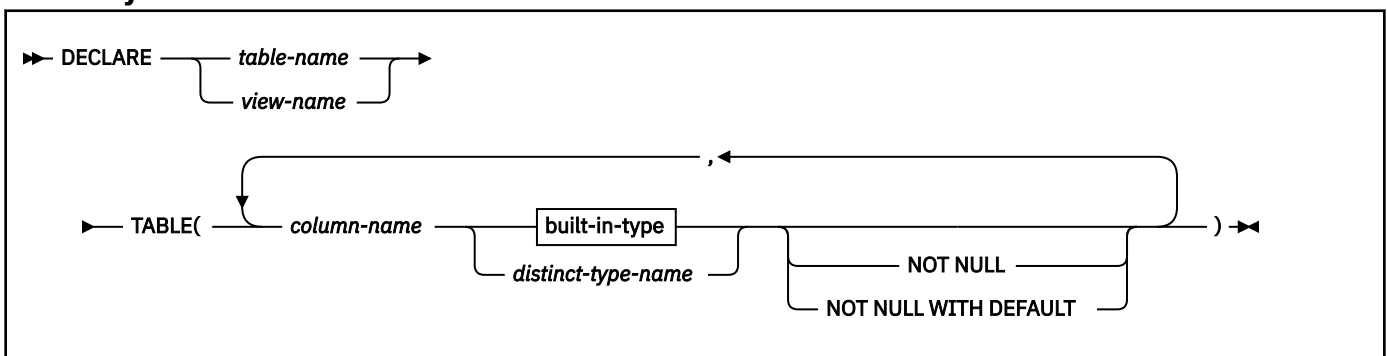

built-in-type:

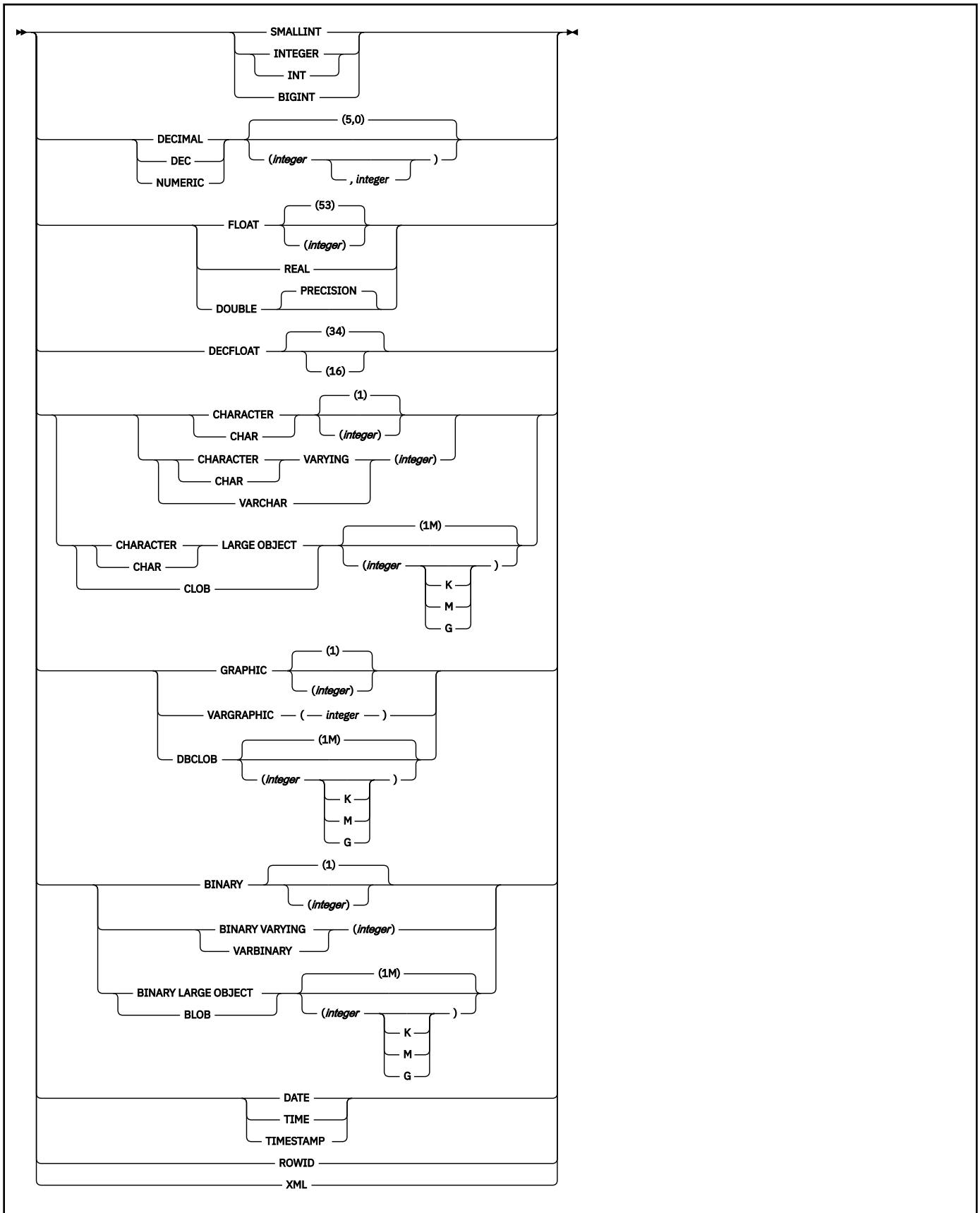

Description for DECLARE TABLE

table-name or view-name

Specifies the name of the table or view to document. If the table is defined in your application program, the description of the table in the SQL statement in which it is defined (for example, CREATE TABLE or DECLARE GLOBAL TEMPORARY TABLE statement) and the DECLARE TABLE statement must be identical.

column-name

Specifies the name of a column of the table or view.

The precompiler uses these names to check for consistency of names within your SQL statements. It also uses the data type to check for consistency of names and data types within your SQL statements.

built-in-type

Specifies the built-in data type of the column. Use one of the built-in data types.

SMALLINT

For a small integer.

INTEGER or INT

For a large integer.

BIGINT

For a big integer.

DECIMAL(*integer, integer*) or DEC(*integer, integer*)

DECIMAL(*integer*) or DEC(*integer*)

DECIMAL or DEC

For a decimal number. The first integer is the precision of the number. That is, the total number of digits, which can range 1–31. The second integer is the scale of the number. That is, the number of digits to the right of the decimal point, which can range from 0 to the precision of the number.

You can use DECIMAL(*p*) for DECIMAL(*p*,0) and DECIMAL for DECIMAL(5,0).

You can also use the word NUMERIC instead of DECIMAL. For example, NUMERIC(8) is equivalent to DECIMAL(8). Unlike DECIMAL, NUMERIC has no allowable abbreviation.

FLOAT(*integer*)

FLOAT

For a floating-point number. If *integer* is in the range 1–21 inclusive, the format is single precision floating-point. If the integer is in the range 22–53 inclusive, the format is double precision floating-point.

You can use DOUBLE PRECISION or FLOAT for FLOAT(53).

REAL

For single precision floating-point.

DOUBLE or DOUBLE PRECISION

For double precision floating-point

DECFLOAT(*integer*)

For a decimal floating-point number. The value of *integer* must be either 16 or 34 and represents the number of significant digits that can be stored. If *integer* is omitted, the DECFLOAT column will be capable of representing 34 significant digits.

CHARACTER(*integer*) or CHAR(*integer*)

CHARACTER or CHAR

For a fixed-length character string of length *integer*, which can range 1–255. If the length specification is omitted, a length of 1 character is assumed.

CCSID 1208

Specifies that the column is a Unicode column encoded in UTF-8. This clause must not be specified for an ASCII or Unicode table.

VARCHAR(*integer*), CHAR VARYING(*integer*), or CHARACTER VARYING(*integer*)

For a varying-length character string of maximum length *integer*, which can range from 1 to the maximum record size minus 10 bytes. See [Table 208 on page 1707](#) to determine the maximum record size.

CCSID 1208

Specifies that the column is a Unicode column encoded in UTF-8. This clause must not be specified for an ASCII or Unicode table.

CLOB(*integer* [K|M|G]), CHAR LARGE OBJECT(*integer* [K|M|G]), or CHARACTER LARGE OBJECT(*integer* [K|M|G])**CLOB, CHAR LARGE OBJECT, or CHARACTER LARGE OBJECT**

For a character large object (CLOB) string of the specified maximum length in bytes. The maximum length must be in the range 1–2147483647. A CLOB column has a varying-length. It cannot be referenced in certain contexts regardless of its maximum length. For more information, see [“Restrictions using LOBs” on page 117](#).

When *integer* is not specified, the default length is 1M. The maximum value that can be specified for *integer* depends on whether a units indicator is also specified as shown in the following list.

integer

The maximum value for *integer* is 2147483647. The maximum length of the string is *integer*.

***integer* K**

The maximum value for *integer* is 2097152. The maximum length is 1024 times *integer*.

***integer* M**

The maximum value for *integer* is 2048. The maximum length is 1,048,576 times *integer*.

***integer* G**

The maximum value for *integer* is 2. The maximum length is 1,073,741,824 times *integer*.

integer can be separated from K, M, or G by 0 or more spaces.

If you specify a value that evaluates to 2 gigabytes (2,147,483,648), Db2 uses a value that is one byte less, or 2147483647.

CCSID 1208

Specifies that the column is a Unicode column encoded in UTF-8. This clause must not be specified for an ASCII or Unicode table.

GRAPHIC(*integer*)**GRAPHIC**

For a fixed-length graphic string of length *integer*, which can range 1–127. If the length specification is omitted, a length of 1 character is assumed.

CCSID 1200

Specifies that the column is a Unicode column encoded in UTF-16. This clause must not be specified for an ASCII or Unicode table.

VARGRAPHIC(*integer*)

For a varying-length graphic string of maximum length *integer*, which must range from 1 to $n/2$, where n is the maximum row size minus 2 bytes.

CCSID 1200

Specifies that the column is a Unicode column encoded in UTF-16. This clause must not be specified for an ASCII or Unicode table.

DBCLOB(*integer* [K|M|G])**DBCLOB**

For a double-byte character large object (DBCLOB) string of the specified maximum length in double-byte characters. The maximum length must be in the range of 1–1,073,741,823. A DBCLOB column has a varying-length. It cannot be referenced in certain contexts regardless of its maximum length. For more information, see [“Restrictions using LOBs” on page 117](#).

When *integer* is not specified, the default length is 1M. The meaning of *integer* K|M|G is similar to CLOB. The difference is that the number specified is the number of double-byte characters.

integer can be separated from K, M, or G by 0 or more spaces.

CCSID 1200

Specifies that the column is a Unicode column encoded in UTF-16. This clause must not be specified for an ASCII or Unicode table.

BINARY(*integer*)

A fixed-length binary string of length *integer*. The *integer* can range 1–255. If the length specification is omitted, a length of 1 byte is assumed.

BINARY VARYING(*integer*) or VARBINARY(*integer*)

A varying-length binary string of maximum length *integer*, which can range 1–32704. The length is limited by the page size of the table space.

BLOB (*integer* [K|M|G]) or BINARY LARGE OBJECT(*integer* [K|M|G])

BLOB or BINARY LARGE OBJECT

For a binary large object (BLOB) string of the specified maximum length in bytes. The maximum length must be in the range of 1–2147483647. A BLOB column has a varying-length. It cannot be referenced in certain contexts regardless of its maximum length. For more information, see [“Restrictions using LOBs” on page 117](#).

When *integer* is not specified, the default length is 1M. The meaning of *integer* K|M|G is the same as for CLOB.

integer can be separated from K, M, or G by 0 or more spaces.

DATE

For a date.

TIME

For a time.

TIMESTAMP(*integer*) WITHOUT TIME ZONE

For a timestamp. *integer* specifies the optional timestamp precision attribute and must be in the range 0–12. The timestamp precision denotes the number of fractional second digits that are included in the timestamp. The default is 6.

TIMESTAMP(*integer*) WITH TIME ZONE

For a timestamp with time zone. *integer* specifies the optional timestamp precision attribute and must be in the range 0–12. The timestamp precision denotes the number of fractional second digits that are included in the timestamp. The default is 6.

ROWID

For a row ID type.

A table can contain at most two ROWID columns. If it contains two, one column is implicitly generated by Db2 and the other column is explicitly defined as a ROWID without the IMPLICITLY HIDDEN attribute. The values in a ROWID column are unique for every row in the table and cannot be updated. You must specify NOT NULL with ROWID.

XML

For an XML document. Only well-formed XML documents can be inserted into an XML column.

If the XML column is the first XML column that you create for the table, a BIGINT DOCID column is implicitly created and is used to store a unique document identifier for the XML columns of a row.

distinct-type-name

Specifies the distinct type (user-defined data type) of the column. An implicit or explicit schema name qualifies the name.

NOT NULL

Specifies that the column does not allow null values and does not provide a default value.

NOT NULL WITH DEFAULT

Specifies that the column does not allow null values but provides a default value.

Notes for DECLARE TABLE

Error handling during processing: If an error occurs during the processing of the DECLARE TABLE statement, a warning message is issued, and the precompiler continues processing your source program.

Documenting a distinct type column: Although you can specify the name of a distinct type as the data type of a column in the DECLARE TABLE statement, use the built-in data type on which the distinct type is based instead. Using the base type enables the precompiler to check the embedded SQL statements for errors; otherwise, error checking is deferred until bind time.

To determine the source data type of the distinct type, check the value of column SOURCETYPE in catalog table SYSDATATYPES.

Examples for DECLARE TABLE

Example 1: Issue a DECLARE TABLE statement for the sample employee table, DSN8C10.EMP.

```
EXEC SQL DECLARE DSN8C10.EMP TABLE
(EMPNO      CHAR(6)      NOT NULL,
 FIRSTNAME  VARCHAR(12)  NOT NULL,
 MIDINIT    CHAR(1)      NOT NULL,
 LASTNAME   VARCHAR(15)  NOT NULL,
 WORKDEPT   CHAR(3)      ,
 PHONENO    CHAR(4)      ,
 HIREDATE   DATE         ,
 JOB        CHAR(8)      ,
 EDLEVEL    SMALLINT     ,
 SEX        CHAR(1)      ,
 BIRTHDATE  DATE         ,
 SALARY     DECIMAL(9,2) ,
 BONUS      DECIMAL(9,2) ,
 COMM       DECIMAL(9,2) );
```

Example 2: Issue a DECLARE TABLE statement for a table that includes a column with a distinct type.

Assume that table CANADIAN_SALES keeps information for your company's sales in Canada. The table includes one column, TOTAL, that is defined as a distinct type. The distinct type CANADIAN_DOLLAR was created with the following definition:

```
CREATE TYPE CANADIAN_DOLLAR AS DECIMAL(9,2);
```

The CANADIAN_SALES table was created with the following definition, which uses the distinct type CANADIAN_DOLLAR as the data type for the TOTAL column.

```
CREATE TABLE CANADIAN_SALES
(PRODUCT_ITEM  INTEGER,
 MONTH         INTEGER,
 YEAR          INTEGER,
 TOTAL         CANADIAN_DOLLAR); -- TOTAL column data type is a distinct type
```

A DECLARE TABLE statement must include only built-in data types. Therefore, in the DECLARE TABLE statement for the CANADIAN_SALES table, you need to use the source data type for the CANADIAN_DOLLAR distinct type, which is DECIMAL(9,2).

```
DECLARE TABLE CANADIAN_SALES
(PRODUCT_ITEM  INTEGER,
 MONTH         INTEGER,
 YEAR          INTEGER,
 TOTAL         DECIMAL(9,2)); -- Define the column using the source built-in data type
```

DECLARE VARIABLE statement

The DECLARE VARIABLE statement defines a CCSID for a host variable and the subtype of the variable. When it appears in an application program, the DECLARE VARIABLE statement causes the

Db2 precompiler to tag a host variable with a specific CCSID. When the host variable appears in an SQL statement, the Db2 precompiler places this CCSID into the structures that it generates for the SQL statement.

Invocation for DECLARE VARIABLE

This statement can only be embedded in an application program. It is not an executable statement.

Authorization for DECLARE VARIABLE

None required.

Syntax for DECLARE VARIABLE

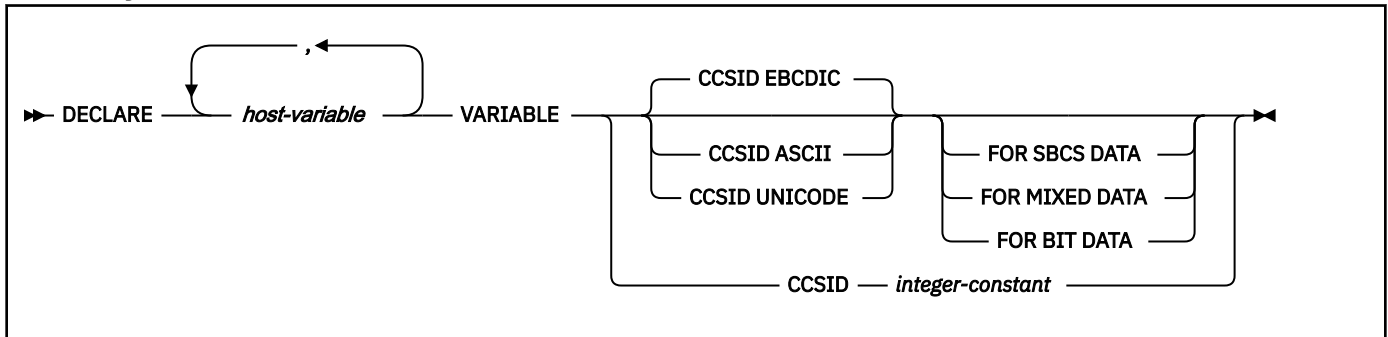

Description for DECLARE VARIABLE

host-variable

Identifies a character or graphic string host variable defined in the program. An indicator variable cannot be specified for the host-variable.

CCSID ASCII, EBCDIC, or UNICODE

Specifies that the appropriate default CCSID for the specified encoding scheme of the server should be used.

CCSID ASCII

Specifies that the default ASCII CCSID for the type of the variable at the server should be used.

CCSID EBCDIC

Specifies that the default EBCDIC CCSID for the type of the variable at the server should be used. CCSID EBCDIC is the default if this option is not specified.

CCSID UNICODE

Specifies that the default UNICODE CCSID for the type of the variable at the server should be used.

FOR SBCS DATA, FOR MIXED DATA, or FOR BIT DATA

Specifies the type of data contained in the variable *host-variable*. The FOR clause cannot be specified when declaring a graphic host variable.

For ASCII or EBCDIC data, if this clause is not specified when declaring a character host variable, the default is FOR SBCS DATA if MIXED DATA = NO on the installation panel DSNTIPF. The default is FOR MIXED DATA if MIXED DATA = YES on the installation panel DSNTIPF.

For UNICODE data, the default is always FOR MIXED DATA, regardless of the setting of MIXED DATA on the installation panel DSNTIPF.

FOR SBCS DATA

Specifies that the values of the host variable can contain only SBCS (single-byte character set) data.

FOR MIXED DATA

Specifies that the values of the host variable can contain both SBCS data and DBCS data.

FOR BIT DATA

Specifies that the values of the host-variable are not associated with a coded character set and, therefore, are never converted. The CCSID of a FOR BIT DATA host variable is 65535.

CCSID *integer-constant*

Specifies that the values of the host variable contain data that is encoded using CCSID *integer-constant*. If the integer is an SBCS CCSID, the host variable is SBCS data. If the integer is a mixed data CCSID, the host variable is mixed data. For character host variables, the CCSID specified must be an SBCS, mixed CCSID, or UNICODE (UTF-8) CCSID. For graphic host variables, the CCSID specified must be a DBCS or UNICODE (UTF-16) CCSID. The valid range of values for the integer is 1–65533.

Notes for DECLARE VARIABLE

Placement of statement: The DECLARE VARIABLE statement can be specified anywhere in an application program that SQL statements are valid with the following exception. The DECLARE VARIABLE statement must occur before an SQL statement that refers to a host variable specified in the DECLARE VARIABLE statement.

CCSID exceptions for EXECUTE IMMEDIATE or PREPARE: When the host variable appears in an SQL statement, the Db2 precompiler places the appropriate numeric CCSID into the structures it generates for the SQL statement. This placement of the CCSID occurs for any SQL statement other than the EXECUTE IMMEDIATE or PREPARE statements. The placement of the CCSID also occurs for a *host-variable* in an EXECUTE IMMEDIATE or PREPARE statement, but it does not occur for a variable in a *string-expression* in an EXECUTE IMMEDIATE or PREPARE statement.

If a PL/I application program contains at least one DECLARE VARIABLE statement, a *string-expression* in any EXECUTE IMMEDIATE or PREPARE statement cannot be preceded by a colon. An expression that consists of just a variable name preceded by a colon is interpreted as a *host-variable*.

Specific host languages: If a DECLARE VARIABLE statement is used in an assembler source program, the ONEPASS SQL processing option must not be used. If a DECLARE VARIABLE statement is used in a C, C++, or PL/I source program, the TWOPASS SQL processing option must be used. For those languages, or COBOL, the host-variable definition can either precede or follow a DECLARE VARIABLE statement that refers to that variable. If a DECLARE VARIABLE statement is used in a FORTRAN source program, then the host-variable definition must precede the DECLARE VARIABLE statement.

Example for DECLARE VARIABLE

Example: Define the following host variables using PL/I data types: FRED as fixed length bit data, JEAN as fixed length UTF-8 (mixed) data, DAVE as varying length UTF-8 (mixed) data, PETE as fixed length graphic UTF-16 data, and AMBER as varying length graphic UTF-16 data.

Use the DECLARE VARIABLE statement to specify a data subtype or CCSID for these host variables: FRED as CCSID EBCDIC, JEAN as CCSID 1208 or CCSID UNICODE, DAVE as CCSID 1208 or CCSID UNICODE, PETE as CCSID 1200 or CCSID UNICODE, and AMBER as CCSID 1200 or CCSID UNICODE.

```
EXEC SQL BEGIN DECLARE SECTION;
  DCL FRED CHAR(10);
  EXEC SQL DECLARE :FRED VARIABLE CCSID EBCDIC FOR BIT DATA;
  DCL JEAN CHAR(30);
  EXEC SQL DECLARE :JEAN VARIABLE CCSID 1208;
  DCL DAVE CHAR(9) VARYING;
  EXEC SQL DECLARE :DAVE VARIABLE CCSID UNICODE;
  DCL PETE GRAPHIC(10);
  EXEC SQL DECLARE :PETE VARIABLE CCSID 1200;
  DCL AMBER GRAPHIC(20) VARYING;
  EXEC SQL DECLARE :AMBER VARIABLE CCSID UNICODE;
EXEC SQL END DECLARE SECTION;
```

DELETE statement

The DELETE statement deletes rows from a table or view. Deleting a row from a view deletes the row from the table on which the view is based if no INSTEAD OF DELETE trigger is defined for this view. If such a trigger is defined, the trigger is activated instead.

The table or view can be at the current server or any Db2 subsystem with which the current server can establish a connection.

There are two forms of this statement:

- The *searched* DELETE form is used to delete one or more rows, optionally determined by a search condition.
- The *positioned* DELETE form specifies that one or more rows corresponding to the current cursor position are to be deleted.

Invocation for DELETE

This statement can be embedded in an application program or issued interactively. A positioned DELETE is embedded in an application program. Both the embedded and interactive forms are executable statements that can be dynamically prepared.

Authorization for DELETE

Authority requirements depend on whether the object identified in the statement is a user-defined table, a catalog table, or a view, and whether the statement is a searched DELETE and SQL standard rules are in effect:

When a table other than a catalog table is identified: The privilege set must include at least one of the following:

- The DELETE privilege on the table
- Ownership of the table
- DBADM authority on the database that contains the table
- SYSADM authority

If the database is implicitly created, the database privileges must be on the implicit database or on DSNDB04.

When a catalog table is identified: The privilege set must include at least one of the following:

- DBADM authority on the catalog database
- SYSCTRL authority
- SYSADM authority

When a view is identified: The privilege set must include at least one of the following:

- The DELETE privilege on the view
- SYSADM authority

If the *search-condition* in a searched DELETE contains a reference to a column of the table or view, or the *expression* in the *assignment-clause* contains a reference to a column of the table or view, the privilege set must include at least one of the following:

- The SELECT privilege on the table or view
- Ownership of the table or view
- DBADM authority on the database that contains the table, if the target is a table and that table that is not a catalog table
- DATAACCESS
- SYSADM authority

If the *search-condition* in a searched DELETE includes a subquery, or if the *assignment-clause* includes a *scalar-fullselect* or a *row-fullselect*, see “Authorization for queries” on page 1007 for an explanation of the authorization required.

The owner of a view, unlike the owner of a table, might not have DELETE authority on the view (or might have DELETE authority without being able to grant it to others). The nature of the view itself can preclude its use for DELETE. For more information, see the description of authority in “CREATE VIEW statement” on page 1812.

If the statement is embedded in an application program, the privilege set is the privileges that are held by the owner of the plan or package. If the statement is dynamically prepared, the privilege set is determined by the DYNAMICRULES behavior in effect (run, bind, define, or invoke) and is summarized in Table 171 on page 1089. (For more information on these behaviors, including a list of the DYNAMICRULES bind option values that determine them, see “Authorization IDs and dynamic SQL” on page 94.)

FL 509 If the statement attempts to delete a row in the SYSIBM.SYSAUDITPOLICIES catalog table that is subject to a tamper-proof audit policy, additional RACF authorization is required. During statement execution, the primary authorization ID or one of the groups associated with the primary authorization ID must be authorized to access the tamper-proof audit policy profile in RACF. For more information on the authorization rules, see Db2 audit policies (Managing Security).

searched delete:

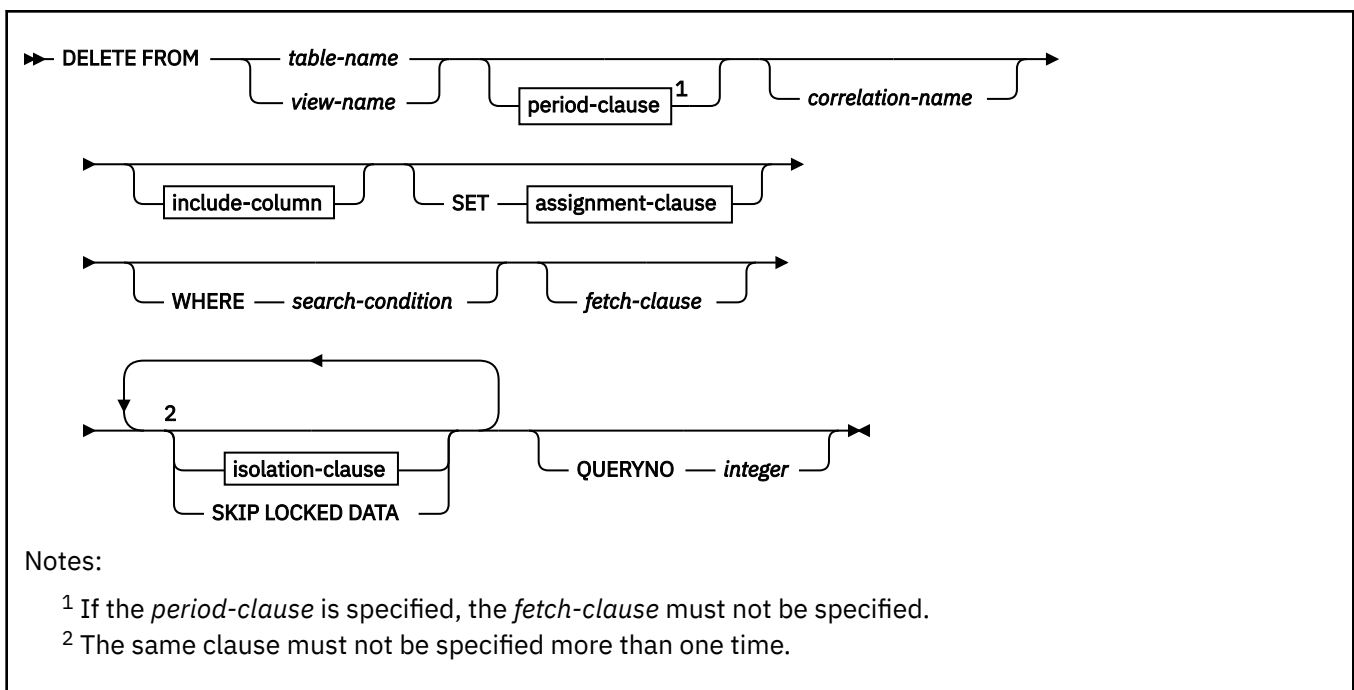

positioned delete:

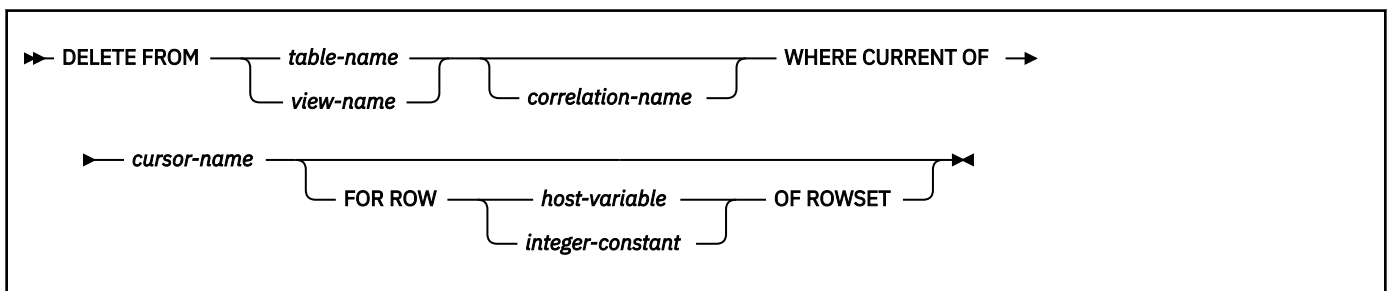

period-clause:

►► FOR PORTION OF BUSINESS_TIME — FROM — *value1* — TO — *value2* — ◄◄
BETWEEN — *value1* — AND — *value2* — ◄◄

include-column:

►► INCLUDE — (— *column-name* — data-type —) — ◄◄

data-type:

►► built-in-type — ◄◄
distinct-type — ◄◄

built-in-type:

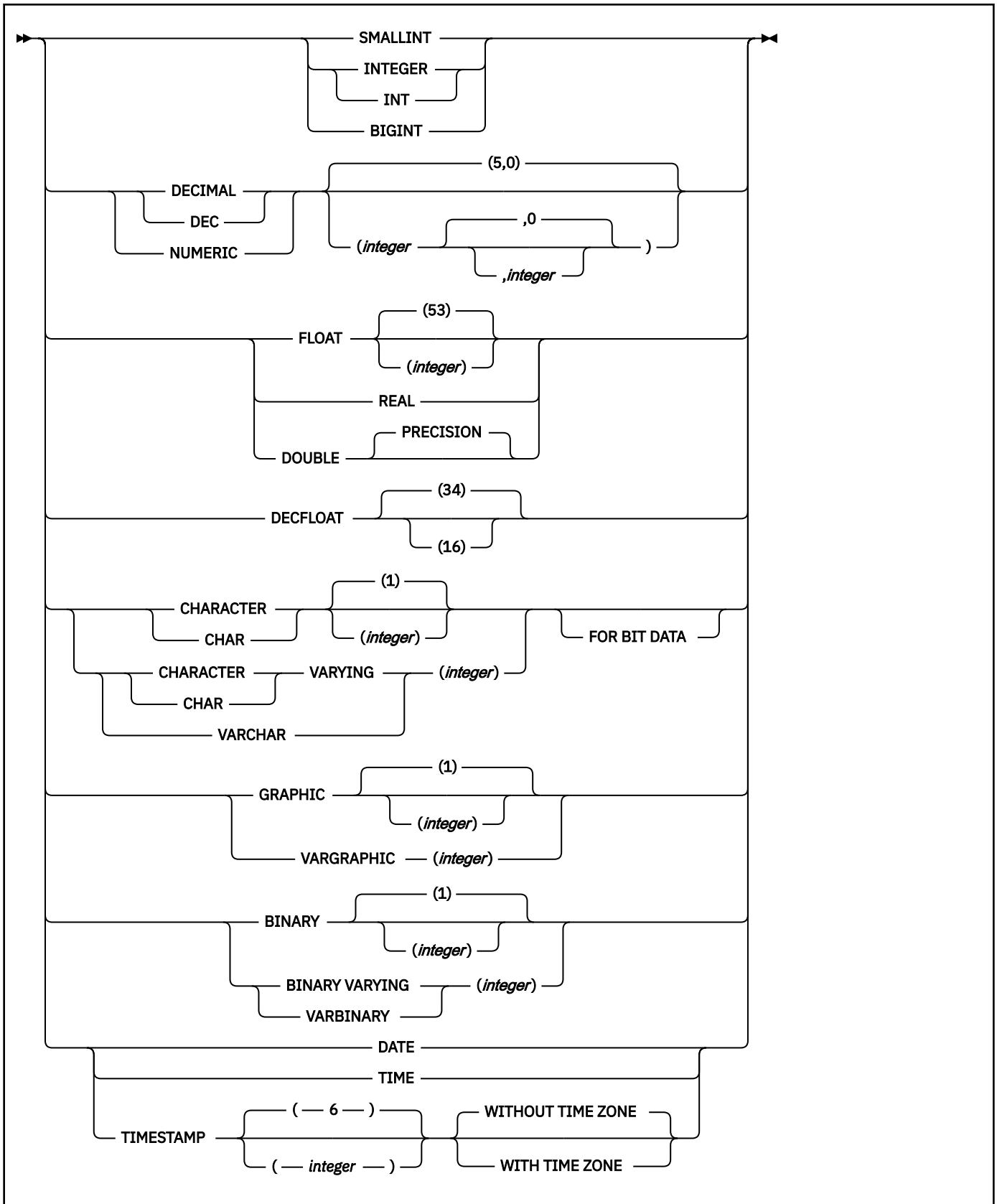

assignment clause:

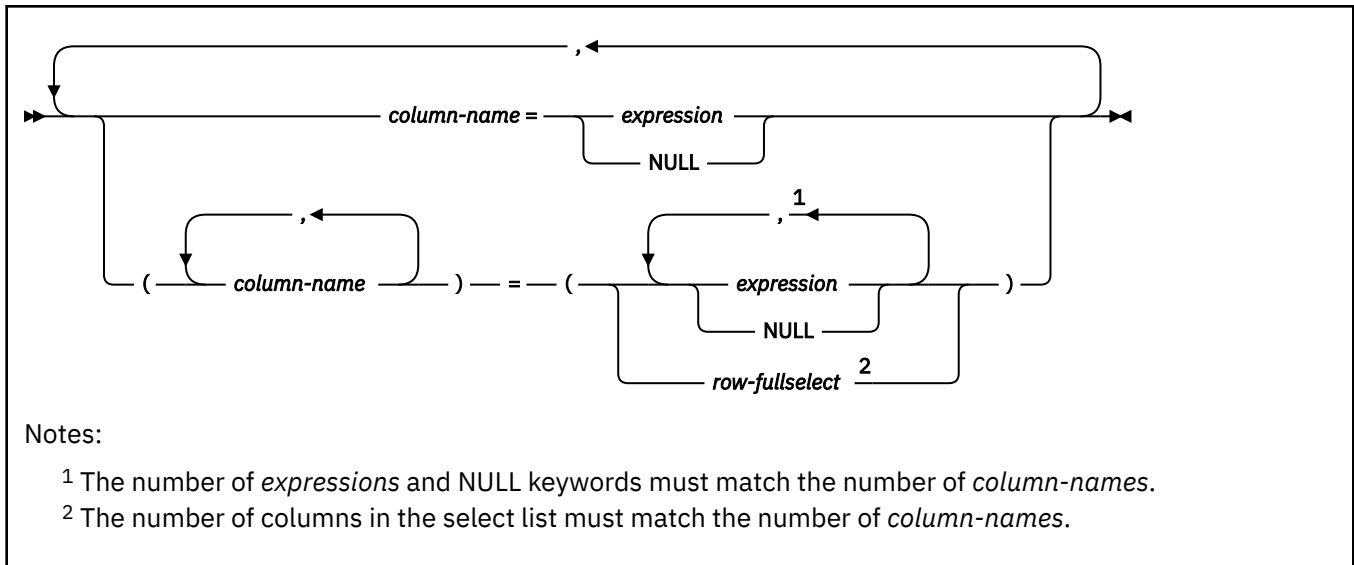

isolation-clause:



Description for DELETE

FROM *table-name* or *view-name*

Identifies the table or view from which rows are to be deleted. The name must identify a table or view that exists at the Db2 subsystem that is identified by the implicitly or explicitly specified location name. The name must not identify:

- An auxiliary table
- A catalog table for which deletes are not allowed
- A view of such a catalog table
- A directory table
- A read-only view (see “CREATE VIEW statement” on page 1812)
- A view that is defined with an instead of trigger if the fetch-clause is specified.
- A created global temporary table if the fetch-clause is specified.
- An accelerator-only table if the fetch-clause is specified.
- A system-maintained materialized query table
- A table that is implicitly created for an XML column
- An archive-enabled table if the SYSIBMADM.GET_ARCHIVE global variable is set to Y, the ARCHIVESENSITIVE bind option is set to YES, and the operation is a positioned delete

In an IMS or CICS application, the Db2 subsystem that contains the identified table or view must be a remote server that supports two-phase commit.

period-clause

Specifies that a period clause applies to the target of the delete operation. The same period name must not be specified more than one time. If the target of the delete operation is a view:

- The FROM clause of the outer fullselect of the view definition must include a reference, directly or indirectly, to an application-period temporal table.
- An INSTEAD OF trigger must not be defined for that view.

FOR PORTION OF BUSINESS_TIME

Specifies that the delete only applies to row values for the portion of the BUSINESS_TIME period in the row that is specified by the period clause. BUSINESS_TIME must be a period that is defined on the table.

FOR PORTION OF BUSINESS_TIME must not be specified if the value of the CURRENT TEMPORAL BUSINESS_TIME special register is not NULL when the BUSTIMESENSITIVE bind option is set to YES.

FROM value1 TO value2

Specifies that the delete operation applies to rows for the period that is specified from *value1* to *value2*. No rows are deleted if *value1* is greater than or equal to *value2*, or if *value1* or *value2* is the null value.

This clause must not be specified for an inclusive-inclusive period.

For the period condition that is specified with FROM *value1* TO *value2*, the period that is specified by *period-name* in a row of the target table of the delete:

- Overlaps the beginning of the specified period if the value of the begin column is less than *value1* and the value of the end column is greater than *value1*.
- Overlaps the end of the specified period if the value of the end column is greater than or equal to *value2* and the value of the begin column is less than *value2*.
- Is fully contained within the specified period if the value for the begin column for *period-name* in the row is greater than or equal to *value1* and the value for the corresponding end column in the row is less than or equal to *value2*.
- Is partially contained in the specified period if the row overlaps the beginning of the specified period or the end of the specified period.
- Fully overlaps the specified period if the period in the row overlaps the beginning of the specified period and overlaps the end of the specified period, .
- Is not contained in the period if both columns of *period-name* are less than or equal to *value1* or are greater than *value2*.

If the period *period-name* in a row is not contained in the specified period, the row is not deleted. Otherwise, the delete operation is applied based on the specification of the PORTION OF clause and how the values in the columns of *period-name* overlap the specified period as follows:

- If the period *period-name* in a row is fully contained within the specified period, the row is deleted.
- If the period *period-name* in a row is partially contained in the specified period and overlaps the beginning of the specified period:
 - The row is deleted.
 - A row is inserted using the original values from the row, except that the end column is set to *value1*, and new values are used for other generated columns.
- If the period *period-name* in a row is partially contained in the specified period and overlaps the end of the specified period:
 - The row is deleted.
 - A row is inserted using the original values from the row, except that the begin column is set to *value2*, and new values are used for other generated columns.
- If the period *period-name* in a row fully overlaps the specified period:
 - The row is deleted.
 - A row is inserted using the original values from the row, except that the end column is set to *value1*, a column defined as DATA CHANGE OPERATION is set to 'I', and new values are used for other generated columns.

- An additional row is inserted using the original values from the row, except that the begin column is set to *value2*, a column defined as DATA CHANGE OPERATION is set to 'I', and new values are used for other generated columns.

Any existing delete triggers are activated for the rows that are deleted, and any existing insert triggers are activated for the rows that are implicitly inserted.

BETWEEN *value1* AND *value2*

Specifies that the delete operation applies to rows for the period that is specified from *value1* up to and including *value2*. No rows are deleted if *value1* is greater than *value2*, or if *value1* or *value2* is the null value. This clause must not be specified for an inclusive-exclusive period.

For the period clause that is specified with BETWEEN *value1* AND *value2*, period *period-name* in a row in the target of the delete covers one of the following ranges:

- Overlaps the beginning of the specified period if the value of the begin column is less than *value1* and the value of the end column is greater than or equal to *value1*.
- Overlaps the end of the specified period if the value of the end column is greater than *value2* and the value of the begin column is less than or equal to *value2*.
- Is fully contained within the specified period if the value for the begin column for *period-name* in the row is greater than or equal to *value1* and the value for the corresponding end column in the row is less than or equal to *value2*.
- Is partially contained in the specified period if the row overlaps the beginning of the specified period or the end of the specified period, but not both .
- fully overlaps the specified period if the period in the row overlaps the beginning of the specified period and overlaps the end of the specified period.
- Is not contained in the period if both columns of *period-name* are less than *value1* or greater than *value2*.

If the period *period-name* in a row is not contained in the specified period, the row is not deleted. Otherwise, the delete operation is based on the following items:

- The specification of the PORTION OF clause.
- How the values in the columns of *period-name* overlap the specified period.
- *spu* (smallest period unit), which depends on the data type of the columns of the period as follows:
 - For a period containing DATE columns, spu is 1 day.
 - For a period containing TIMESTAMP(6) columns, spu is 1 microsecond.

Based on those items, the delete operation is applied as follows:

- If the period *period-name* in a row is fully contained within the specified period, the row is deleted.
- If the period *period-name* in a row is partially contained in the specified period and overlaps the beginning of the specified period:
 - The row is deleted.
 - A row is inserted using the original values from the row, except that the end column is set to *value1* - spu, and new values are used for other generated columns.
- If the period *period-name* in a row is partially contained in the specified period and overlaps the end of the specified period:
 - The row is deleted.
 - A row is inserted using the original values from the row, except that the begin column is set to *value2* + spu, and new values are used for other generated columns.
- If the period *period-name* in a row fully overlaps the specified period:
 - The row is deleted.

- A row is inserted using the original values from the row, except that the end column is set to *value1* - spu, and new values are used for other generated columns.
- An additional row is inserted using the original values from the row, except that the begin column is set to *value2* + spu, and new values are used for other generated columns.

value1, value2

Specifies expressions that return a value of a built-in data type. The result of each expression must be comparable to the data type of the columns of the specified period. See the comparison rules described in [“Assignment and comparison” on page 143](#). Each expression can contain any of the following supported operands:

- A constant
- A special register
- A variable
- An array element specification
- A built-in scalar function whose arguments are supported operands
- A CAST specification where the cast operand is a supported operand
- An expression that uses arithmetic operators and operands

Each expression must not have a timestamp precision that is greater than the precision of the columns for the period.

If the begin and end columns of the period are defined as `TIMESTAMP WITHOUT TIME ZONE`, each expression must not return a value of a timestamp with a time zone.

A period clause for a view must not contain an untyped parameter marker.

correlation-name

Specifies an alternate name that can be used within the *search-condition* to designate the table or view. (For an explanation of correlation names, see [“Correlation names” on page 220](#).)

include-column

Specifies a set of columns that are included, along with the columns of *table-name* or *view-name*, in the result table of the DELETE statement when it is nested in the FROM clause of the outer fullselect that is used in a subselect, SELECT statement, or in a SELECT INTO statement. The included columns are appended to the end of the list of columns that is identified by *table-name* or *view-name*. If no value is assigned to a column that is specified by an *include-column*, a NULL value is returned for that column.

INCLUDE

Introduces a list of columns that are to be included in the result table of the DELETE statement. The included columns are only available if the DELETE statement is nested in the FROM clause of a SELECT statement or a SELECT INTO statement.

column-name

Specifies the name for a column of the result table of the DELETE statement that is not the same name as another included column nor a column in the table or view that is specified in *table-name* or *view-name*.

data-type

Specifies the data type of the included column. The included columns are nullable.

built-in-type

Specifies a built-in data type. See [“CREATE TABLE statement” on page 1650](#) for a description of each built-in type.

The CCSID 1208 and CCSID 1200 clauses must not be specified for an INCLUDE column.

distinct-type

Specifies a distinct type. Any length, precision, or scale attributes for the column are those of the source type of the distinct type as specified by using the CREATE TYPE statement.

SET

Introduces the assignment of values to columns.

assignment-clause

The assignment-clause introduces a list of one or more *column-names* and the values that are to be assigned to the columns. The *column-names* are the only columns that can be set using the *assignment-clause*.

column-name

Identifies an INCLUDE column.

Assignments to included columns are only processed when the DELETE statement is nested in the FROM clause of a SELECT statement or a SELECT INTO statement. The columns that are named in the INCLUDE clause are the only columns that can be set using the SET clause. The null value is returned for an included column that is not set by using an explicit SET clause.

expression

Indicates the new value of the column. The *expression* is any expression of the type described in [“Expressions” on page 245](#). It must not include an aggregate function.

A *column-name* in an expression must identify a column of the table or view. For each row that is deleted, the value of the column in the expression is the value of the column in the row before the row is deleted.

NULL

Specifies the null value as the new value of the column. Specify NULL only for nullable columns.

row-fullselect

Specifies a fullselect that returns a single row. The column values are assigned to each of the corresponding *column-names*. If the fullselect returns no rows, the null value is assigned to each column; an error occurs if any column that is to be deleted is not nullable. An error also occurs if there is more than one row in the result.

If the fullselect refers to columns that are to be deleted, the value of such a column in the fullselect is the value of the column in the row before the row is deleted.

WHERE

Specifies the rows to be deleted. You can omit the clause, give a search condition, or specify a cursor. For a created temporary table or a view of a created temporary table, you must omit the clause. When the clause is omitted, all the rows of the table or view are deleted.

search-condition

Is any search condition as described in Chapter 2, [“Language elements in SQL,” on page 75](#). Each *column-name* in the search condition, other than in a subquery, must identify a column of the table or view.

The search condition is applied to each row of the table or view and the deleted rows are those for which the result of the search condition is true.

If the search condition contains a subquery, the subquery can be thought of as being executed each time the search condition is applied to a row, and the results used in applying the search condition. In actuality, a subquery with no correlated references is executed just once, whereas it is possible that a subquery with a correlated reference must be executed once for each row.

Let T2 denote the object table of a DELETE statement and let T1 denote a table that is referred to in the FROM clause of a subquery of that statement. T1 must not be a table that can be affected by the DELETE on T2. Thus, the following rules apply:

- T1 must not be a dependent of T2 in a relationship with a delete rule of CASCADE or SET NULL, unless the result of the subquery is materialized before the DELETE action is executed.
- T1 must not be a dependent of T3 in a relationship with a delete rule of CASCADE or SET NULL if deletes of T2 cascade to T3.

fetch-clause

Limits the effects of the delete to a subset of the qualifying rows. See [“fetch-clause” on page 1047](#) for details.

WHERE CURRENT OF *cursor-name*

Identifies the cursor to be used in the delete operation. *cursor-name* must identify a declared cursor as explained in the description of the DECLARE CURSOR statement in [“DECLARE CURSOR statement” on page 1819](#). If the DELETE statement is embedded in a program, the DECLARE CURSOR statement must include *select-statement* rather than *statement-name*.

The table or view named must also be named in the FROM clause of the SELECT statement of the cursor, and the result table of the cursor must be capable of being deleted. For an explanation of read-only result tables, see [Read-only cursors](#). Note that the object of the DELETE statement must not be identified as the object of the subquery in the WHERE clause of the SELECT statement of the cursor.

If the cursor is ambiguous and the plan or package was bound with CURRENTDATA(NO), Db2 might return an error to the application if DELETE WHERE CURRENT OF is attempted for any of the following:

- A cursor that is using block fetching
- A cursor that is using query parallelism
- A cursor that is positioned on a row that has been modified by this or another application process

When the DELETE statement is executed, the cursor must be open and positioned on a row or rowset of the result table.

- If the cursor is positioned on a single row, that row is the one deleted, and after the deletion the cursor is positioned before the next row of its result table. If there is no next row, the cursor positioned after the last row.
- If the cursor is positioned on a rowset, all rows corresponding to the rows of the current rowset are deleted, and after the deletion the cursor is positioned before the next rowset of its result table. If there is no next rowset, the cursor positioned after the last rowset.

A positioned DELETE must not be specified for a cursor that references a view on which an instead of delete trigger is defined, even if the view is an updatable view.

FOR ROW *n* OF ROWSET

Specifies which row of the current rowset is to be deleted. The corresponding row of the rowset is deleted, and the cursor remains positioned on the current rowset. If the rowset consists of a single row, or all other rows in the rowset have already been deleted, then the cursor is positioned before the next rowset of the result table. If there is no next rowset, the cursor is positioned after the last rowset.

host-variable or *integer-constant* is assigned to an integral value *k*. If *host-variable* is specified, it must be an exact numeric type with scale zero, must not include an indicator variable, and *k* must be in the range 1–32767. The cursor must be positioned on a rowset, and the specified value must be a valid value for the set of rows most recently retrieved for the cursor.

If the specified row cannot be deleted, an error is returned. It is possible that the specified row is within the bounds of the rowset most recently requested, but the current rowset contains less than the number of rows that were implicitly or explicitly requested when that rowset was established.

If, via a positioned delete against a sensitive static cursor that specifies a particular row of the current rowset, and that row has been identified as a delete hole (that is, a row in the result table whose corresponding row has deleted from the base table), an error is returned.

If, via a positioned delete against a sensitive static cursor that specifies a particular row of the current rowset, and that row has been identified as an update hole (that is, a row in the result table whose corresponding row has been updated so that it no longer satisfies a predicate of the SELECT statement), an error is returned.

It is possible for another application process to delete a row in the base table of the SELECT statement so that the specified row of the cursor no longer has a corresponding row in the base table. An attempt to delete such a row results in an error.

If the FOR ROW n OF ROWSET clause is not specified, the current position of cursor determines the rows that are affected by the statement:

- If the cursor is positioned on a single row, that row is the one deleted. After the row is deleted, the cursor is positioned before the next row of its result table. If there is no next row, the cursor positioned after the last row.
- If the cursor is positioned on a rowset, all rows corresponding to the rows of the current rowset are deleted. After the rows are deleted, the cursor is positioned before the next rowset of its result table. If there is no next rowset, the cursor positioned after the last rowset.

isolation-clause

Specifies the isolation level used when locating the rows to be deleted by the statement.

WITH

Introduces the isolation level, which may be one of the following:

RR

Repeatable read

RS

Read stability

CS

Cursor stability

The default isolation level of the statement is the isolation level of the package or plan in which the statement is bound, with the package isolation taking precedence over the plan isolation. When a package isolation is not specified, the plan isolation is the default.

SKIP LOCKED DATA

The SKIP LOCKED DATA clause specifies that rows are skipped when incompatible locks are held on the row by other transactions. These rows can belong to any accessed table that is specified in the statement. SKIP LOCKED DATA can be used only when isolation CS or RS is in effect and applies only to row level or page level locks.

For DELETE statements, SKIP LOCKED DATA can be specified only in the searched form of the DELETE statement. SKIP LOCKED DATA is ignored if it is specified when the isolation level that is in effect is repeatable read (WITH RR) or uncommitted read (WITH UR). The default isolation level of the statement depends on the isolation level of the package or plan with which the statement is bound, with the package isolation taking precedence over the plan isolation. When a package isolation is not specified, the plan isolation is the default.

QUERYNO *integer*

Specifies the number to be used for this SQL statement in EXPLAIN output and trace records. The number is used for the QUERYNO column of the plan table for the rows that contain information about this SQL statement. This number is also used in the QUERYNO column of the SYSIBM.SYSSTMT and SYSIBM.SYSPACKSTMT catalog tables.

If the clause is omitted, the number associated with the SQL statement is the statement number assigned during precompilation. Thus, if the application program is changed and then precompiled, that statement number might change.

Using the QUERYNO clause to assign unique numbers to the SQL statements in a program is helpful:

- For simplifying the use of optimization hints for access path selection
- For correlating SQL statement text with EXPLAIN output in the plan table

For more information about enabling and using optimization hints, see [Influencing access path selection \(Db2 Performance\)](#)

For information on accessing the plan table, see [Investigating SQL performance by using EXPLAIN \(Db2 Performance\)](#).

Notes for DELETE

Delete operation errors:

If an error occurs during the execution of any delete operation, no changes are made. If an error occurs during the execution of a positioned delete, the position of the cursor is unchanged. However, it is possible for an error to make the position of the cursor invalid, in which case the cursor is closed. It is also possible for a delete operation to cause a rollback, in which case the cursor is closed.

Position of cursor:

If an application process deletes a row on which any of its cursors are positioned, those cursors are positioned before the next row of the result table. Let C be a cursor that is positioned before row R (as a result of an OPEN, a DELETE through C, a DELETE through some other cursor, or a searched DELETE). In the presence of an SQL data change statements that affect the base table from which R is derived, the next FETCH operation referencing C does not necessarily position C on R. For example, the operation can position C on R', where R' is a new row that is now the next row of the result table.

Locking:

Unless appropriate locks already exist, one or more exclusive locks are acquired during the execution of a successful delete operation. Until the locks are released by a commit or rollback operation, the effect of the delete operation can only be perceived by the application process that performed the deletion and the locks can prevent other application processes from performing operations on the table. Locks are not acquired when rows are deleted from a declared temporary table unless all the rows are deleted (DELETE FROM T). When all the rows are deleted from a declared temporary table, a segmented table lock is acquired on the pages for the table and no other table in the table space is affected.

Triggers:

Delete operations can cause triggers to be activated. A trigger might cause other statements to be executed or might raise error conditions that are based on the deleted rows. If a DELETE statement on a view causes an INSTEAD OF trigger to be activated, referential integrity is checked against the updates that are performed in the trigger and not against the underlying tables of the view that cause the trigger to be activated.

Triggers defined on a table for which row or column access control is also enforced:

Row permissions and column masks are not applied to the initial values of transition variables and transition tables. Row and column access control that is enforced for the triggering table is also ignored for any transition variables or transition tables that are referenced in the trigger body or that are passed as arguments to user-defined functions that are invoked in the trigger body. To ensure that no security concern exists for SQL statements in the trigger action (access to sensitive data in transition variables and transition tables, for example), the trigger must be secure. For information about securing a trigger, see [“CREATE TRIGGER statement \(basic trigger\)”](#) on page 1769 and [“ALTER TRIGGER statement \(basic trigger\)”](#) on page 1365.

Referential integrity:

If the identified table or the base table of the identified view is a parent, the rows selected must not have any dependents in a relationship with a delete rule of RESTRICT or NO ACTION. In addition, the delete operation must not cascade to descendent rows that have dependents in a relationship with a delete rule of RESTRICT or NO ACTION.

If the delete operation is not prevented by a RESTRICT or NO ACTION delete rule, the selected rows are deleted and any rows that are dependents of the selected rows are also deleted.

- The nullable columns of foreign keys in any rows that are their dependents in a relationship governed by a delete rule of SET NULL are set to the null value.
- Any rows that are their dependents in a relationship governed by a delete rule of CASCADE are also deleted, and these rules apply, in turn, to those rows.

The only difference between NO ACTION and RESTRICT is when the referential constraint is enforced. RESTRICT (IBM SQL rules) enforces the rule immediately, and NO ACTION (SQL standard rules) enforces the rule at the end of the statement. This difference matters only in the case of a searched DELETE involving a self-referencing constraint that deletes more than one row. NO ACTION might allow the DELETE to be successful where RESTRICT (if it were allowed) would prevent it.

Check constraint:

A check constraint can prevent the deletion of a row in a parent table when there are dependents in a relationship with a delete rule of SET NULL. If deleting a row in the parent table would cause a column in a dependent table to be set to null and there is a check constraint that specifies that the column must not be null, the row is not deleted.

Referential constraints defined on a table for which row or column access control is enforced:

Row and column access controls do not effect referential constraints.

Nesting user-defined functions or stored procedures:

A DELETE statement can implicitly or explicitly refer to user-defined functions or stored procedures. This is known as *nesting* of SQL statements. A user-defined function or stored procedure that is nested within the DELETE must not access the table from which you are deleting rows.

Indexes with VARBINARY columns:

If the identified table has an index on a VARBINARY column or a column that is a distinct type that is based on VARBINARY data type, that index column cannot specify the DESC attribute. To use the SQL data change operation on the identified table, either drop the index or alter the data type of the column to BINARY and then rebuild the index.

Number of rows deleted:

Except as noted below, a delete operation sets SQLERRD(3) in the SQLCA to the number of deleted rows. This number does not include any rows that were deleted as a result of a CASCADE delete rule or a trigger.

DELETE FROM T without a WHERE clause deletes all rows of T. If a table T is contained in a segmented table space and is not a parent table, this deletion will be performed without accessing T. The SQLERRD(3) field is set to -1. (For a complete description of the SQLCA, including exceptions to the above, see [Appendix F, “SQL communication area \(SQLCA\),” on page 2303.](#)

Rules for positioned DELETE with SENSITIVE STATIC scrollable cursor:

When a SENSITIVE STATIC scrollable cursor has been declared, the following rules apply:

- *Delete attempt of delete holes or update holes.* If, with a positioned delete against a SENSITIVE STATIC scrollable cursor, an attempt is made to delete a row that has been identified as a delete hole (that is, a row in the result table whose corresponding row has been deleted from the base table), an error occurs.

If an attempt is made to delete a row that has been identified as an update hole (that is, a row in the result table whose corresponding row has been updated so that it no longer satisfies the predicate of the SELECT statement), an error occurs.

- *Delete operations.* Positioned delete operations with SENSITIVE STATIC scrollable cursors perform as follows:
 1. The SELECT list items in the target row of the base table of the cursor are compared with the values in the corresponding row of the result table (that is, the result table must still agree with the base table). If the values are not identical, the delete operation is rejected and an error occurs. The operation can be attempted again after a successful FETCH SENSITIVE has occurred for the target row.
 2. The WHERE clause of the SELECT statement is re-evaluated to determine whether the current values in the base table still satisfy the search criteria. The values in the SELECT list are compared to determine that these values have not changed. If the WHERE clause evaluates as true, and the values in the SELECT list have not changed, the delete operation is allowed to proceed. Otherwise, an error occurs, the delete operation is rejected, and an update hole appears in the cursor.

3. After the base table row is successfully deleted, the temporary result table is updated and the row is marked as a delete hole.

- *Rollback of delete holes.* Delete holes are usually permanent. Once a delete hole is identified, it remains a delete hole until the cursor is closed. However, if a positioned delete using *this* cursor actually caused the creation of the hole (that is, this cursor was used to make the changes that resulted in the hole) and the delete was subsequently rolled back, then the row is no longer considered a delete hole.
- *Result table.* Any deletes, either positioned or searched, to rows of the base table on which a SENSITIVE STATIC scrollable cursor is defined are reflected in the result table if a positioned update or positioned delete is attempted with the scrollable cursor. A SENSITIVE STATIC scrollable cursor sees these deletes when a FETCH SENSITIVE is attempted.

If the FOR ROW *n* OF ROWSET clause is not specified, the entire rowset fetched by the most recent FETCH statement that returned data for the specified cursor is deleted.

Referencing columns that will be updated:

If a cursor uses FETCH statements to retrieve columns that will be updated later, specify FOR UPDATE OF when you select the columns. Then specify WHERE CURRENT OF in the subsequent UPDATE or DELETE statements. These clauses prevent Db2 from selecting access through an index on the columns that are being updated, which might otherwise cause Db2 to read the same row more than once.

For more information, see [Updating previously retrieved data \(Db2 Application programming and SQL\)](#).

Deleting rows from a table with multilevel security:

When you delete rows from a table with multilevel security, Db2 compares the security label of the user (the primary authorization ID) to the security label of the row. The delete proceeds according to the following rules:

- If the security label of the user and the security label of the row are equivalent, the row is deleted.
- If the security label of the user dominates the security label of the row, the user's write-down privilege determines the security the result of the DELETE statement:
 - If the user has write-down privilege or write-down control is not enabled, the row is deleted.
 - If the user does not have write-down privilege and write-down control is enabled, the row is not deleted.
- If the security label of the row dominates the security label of the user, the row is not deleted.

Deleting rows from a table for which row and column access control is enforced:

When a DELETE statement is issued for a table for which row access control is enforced, the rules specified in the row permissions affect whether a row can be deleted. Typically those rules are based on the authorization ID or role of the process.

A table for which row access control is enforced has at least one row permission, the default row permission that prevents all access to the table. When multiple row permissions are defined and enabled for a table, a row access control search condition is derived by using the logical OR operator to the search condition in each enabled permission. This row access control search condition is applied to the table to determine which rows are accessible to the authorization ID or role of the DELETE statement. If the WHERE clause is specified in the DELETE statement, the user-specified predicates are applied on the accessible rows to determine the rows to be deleted. If there is no WHERE clause, the accessible rows are the rows to be deleted.

If there are rows to be deleted, and there is a DELETE trigger for the table, the trigger is activated.

When a DELETE statement is issued for a table for which column access control is enforced, column masks do not affect the DELETE statement.

The preceding rules are not applicable to *include-columns*. *include-columns* are subject to the rules for the select list because they are not the columns of the object table of the DELETE statement.

Other SQL statements in the same unit of work:

The following statements cannot follow a DELETE statement in the same unit of work:

- An ALTER TABLE statement that changes the data type of a column (ALTER COLUMN SET DATA TYPE)
- An ALTER INDEX statement that changes the padding attribute of an index with varying-length columns (PADDED to NOT PADDED or vice versa)
- A CREATE TABLE statement that creates an accelerator-only table.
- An INSERT, UPDATE or DELETE statement that updates an accelerator-only table from a different accelerator

Considerations for a system-period temporal table:

If the DELETE statement has a search condition that contains a correlated subquery that references the history table (explicitly referencing the name of the history table or implicitly referenced through the use of a period specification in the FROM clause), the deleted rows that are stored as historical rows are potentially visible for delete operations for the rows that are subsequently processed for the statement.

The mass delete operation is not used for a DELETE statement that does not contain a search condition if the table is defined as a system-period temporal table.

If the CURRENT TEMPORAL SYSTEM_TIME special register is set to a non-null value, the underlying target of the DELETE statement cannot be a system-period temporal table. This restriction applies regardless of whether the system-period temporal table is directly or indirectly referenced.

Considerations for a history table:

When a row of a system-period temporal table is deleted, a historical copy of the row is inserted into the corresponding history table and the end timestamp of the historical row is captured in the form of a system determined value that corresponds to the time of the data change operation. If the value of the SYSIBM.TEMPORAL_LOGICAL_TRANSACTION_TIME built-in global variable at the time of the data change operation is null, the value is generated using a reading of the time-of-day clock during execution of the first data change statement in the unit of work that requires a value to be assigned to a row-begin column or transaction-start-ID column in a table, or a row in a systemperiod temporal table is deleted. Otherwise, the value is assigned from the SYSIBM.TEMPORAL_LOGICAL_TRANSACTION_TIME built-in global variable at the time of the data change operation. If a conflicting transaction is updating the same row in the system-period temporal table and the row that is to be inserted into the associated history table will have a value for the end column that is greater than the value of the corresponding begin column, an error is returned.

Considerations for an application-period temporal table:

A DELETE statement that contains a FOR PORTION OF BUSINESS_TIME clause for an application-period temporal table indicates the two points in time between which the specified delete operations are effective.

Suppose that FOR PORTION OF BUSINESS_TIME is specified and the period value for a row is only partially contained in the period that is specified from *value1* up to *value2* or between *value1* and *value2*. (The period value for a row is specified by the values of the begin column and end column.) In this case, the row is deleted and one or two rows are automatically inserted to represent the portion of the row that is not deleted. For each row that is automatically inserted as a result of a delete operation on the table, new values are generated for each generated column in the application-period temporal table. If a generated column is defined as part of a unique or primary key, parent key in a referential constraint, or unique index, an automatic insert might violate a constraint or index. In this case, an error is returned.

When an application-period table is the target of a DELETE statement and the value in effect for the CURRENT TEMPORAL BUSINESS_TIME special register is not the null value, Db2 adds the following additional predicates to the statement:

- inclusive-exclusive period:

```
bt_begin <= CURRENT TEMPORAL BUSINESS_TIME AND
bt_end > CURRENT TEMPORAL BUSINESS_TIME
```

- inclusive-inclusive period:

```
bt_begin <= CURRENT TEMPORAL BUSINESS_TIME AND
bt_end >= CURRENT TEMPORAL BUSINESS_TIME
```

In the preceding code, `bt_begin` and `bt_end` are the begin and end columns of the `BUSINESS_TIME` period of the target table of the `DELETE` statement.

Deleting rows from archive-enabled tables:

If the target of the `DELETE` statement is an archive-enabled table, existing rows in the associated archive table are not affected.

When a row of an archive-enabled table is deleted, the effect on the associated archive table is determined by the setting of the `SYSIBMADM.MOVE_TO_ARCHIVE` global variable. If the global variable is set to `Y`, a copy of a deleted row is inserted into the associated archive table. Otherwise, a copy of a deleted row is not inserted into the associated archive table.

A data change statement cannot reference an archive-enabled table when a system-period temporal table or application-period temporal table is also referenced.

Syntax alternatives:

For compatibility with other SQL implementations, the `FROM` keyword that immediately follows the `DELETE` keyword can be omitted.

Examples for DELETE

Assume that the statements in the examples are embedded in PL/I programs.

Example 1

From the table `DSN8C10.EMP` delete the row on which the cursor `C1` is currently positioned.

```
EXEC SQL DELETE FROM DSN8C10.EMP WHERE CURRENT OF C1;
```

Example 2

From the table `DSN8C10.EMP`, delete all rows for departments `E11` and `D21`.

```
EXEC SQL DELETE FROM DSN8C10.EMP
WHERE WORKDEPT = 'E11' OR WORKDEPT = 'D21';
```

Example 3

From employee table `X`, delete the employee who has the most absences.

```
EXEC SQL DELETE FROM EMP X
WHERE ABSENT = (SELECT MAX(ABSENT) FROM EMP Y
WHERE X.WORKDEPT = Y.WORKDEPT);
```

Example 4

Assuming that cursor `CS1` is positioned on a rowset consisting of 10 rows of table `T1`, delete all 10 rows in the rowset.

```
EXEC SQL DELETE FROM T1 WHERE CURRENT OF CS1;
```

Example 5

Assuming cursor `CS1` is positioned on a rowset consisting of 10 rows of table `T1`, delete the fourth row of the rowset.

```
EXEC SQL DELETE FROM T1 WHERE CURRENT OF CS1 FOR ROW 4 OF ROWSET;
```

Example 6

Delete rows in table T1 if the value for column COL2 matches the cardinality of array INTA. The array INTA is specified as an argument for the CARDINALITY function in the DELETE statement.

```
CREATE TYPE INTARRAY AS INTEGER ARRAY[6];
CREATE VARIABLE INTA AS INTARRAY;
SET INTA = ARRAY[1, 2, 3, 4, 5];
CREATE TABLE T1 (COL1 CHAR(7), COL2 INT);
INSERT INTO T1 VALUES('abc', 10);
DELETE FROM T1 WHERE COL2 = CARDINALITY(INTA);
```

Example 7

Delete only 3 rows from table T1 where the value of column C2 is greater than 10.

```
DELETE FROM T1
WHERE C2 > 10
FETCH FIRST 3 ROWS ONLY;
```

DESCRIBE statement

The DESCRIBE statement obtains information about an object. You can obtain the following types of information with this statement, each of which is described separately.

Cursors

Gets information about the result set that is associated with the cursor. This information, such as column information, is put into a descriptor. See [“DESCRIBE CURSOR statement” on page 1869](#).

Input parameter markers of a prepared statement.

Gets information about the input parameter markers in a prepared statement. This information is put into a descriptor. See [“DESCRIBE INPUT statement” on page 1871](#).

The output of a prepared statement

Gets information about a prepared statement or information about the select list columns in a prepared SELECT statement. This information is put into a descriptor. See [“DESCRIBE OUTPUT statement” on page 1873](#).

Procedures

Gets information about the result sets returned by a stored procedure. The information, such as the number of result sets, is put into a descriptor. See [“DESCRIBE PROCEDURE statement” on page 1879](#).

Tables

Gets information about a table or view. This information is put into a descriptor. See [“DESCRIBE TABLE statement” on page 1881](#).

DESCRIBE CURSOR statement

The DESCRIBE CURSOR statement obtains information about the result set that is associated with the cursor. The information, such as column information, is put into a descriptor. Use DESCRIBE CURSOR for result set cursors from stored procedures. The cursor must be defined with the ALLOCATE CURSOR statement.

Invocation for DESCRIBE CURSOR

This statement can only be embedded in an application program. It is an executable statement that cannot be dynamically prepared.

Authorization for DESCRIBE CURSOR

None required.

Syntax for DESCRIBE CURSOR

```
► DESCRIBE CURSOR — cursor-name — INTO — descriptor-name ►  
                  └── host-variable ─┘
```

Description for DESCRIBE CURSOR

cursor-name or *host-variable*

Identifies a cursor by the specified *cursor-name* or the cursor name contained in *host-variable*. The name must identify a cursor that has already been allocated in the source program.

A column of the result table of the cursor must not be an array.

If *host-variable* is used:

- It must be a character string variable that has a maximum length of 18 bytes.
- It must not be followed by an indicator variable.
- The cursor name must be left justified within the host variable and must not contain embedded blanks.
- If the length of the cursor name is less than the length of the host variable, it must be padded on the right with blanks.

Exception: The syntax described above applies to all languages except REXX. For REXX, the syntax is DESCRIBE CURSOR :*hostvar* INTO :*descriptor-name*.

INTO *descriptor-name*

Identifies an SQL descriptor area (SQLDA). The information returned in the SQLDA describes the columns in the result set associated with the named cursor.

The considerations for allocating and initializing the SQLDA are similar to those of a varying-list SELECT statement. For more information, see [Including dynamic SQL for varying-list SELECT statements in your program \(Db2 Application programming and SQL\)](#).

For REXX: The SQLDA is not allocated before it is used.

After the DESCRIBE CURSOR statement is executed, the contents of the SQLDA are the same as after a DESCRIBE for a SELECT statement, with the following exceptions:

- The first 5 bytes of the SQLDAID field are set to 'SQLRS'.
- Bytes 6 to 8 of the SQLDAID field are reserved. If the cursor is declared WITH HOLD in a stored procedure, the high-order bit of the 8th byte is set to 1.

These exceptions do not apply to a REXX SQLDA, which does not include the SQLDAID field.

Notes for DESCRIBE CURSOR

Using cursors for result sets

Column names are included in the information that DESCRIBE CURSOR obtains when the statement that generates the result set is either:

- Dynamic
- Static and the value of field DESCRIBE FOR STATIC on installation panel DSNTIP4 was YES when the package or stored procedure was bound. If the value of the field was NO, the returned information includes only the data type and length of the columns.

Using host variables

If the DESCRIBE CURSOR statement contains host variables, the contents of the host variables are assumed to be in the encoding scheme that was specified in the ENCODING parameter when the package or plan that contains the statement was bound.

Examples for DESCRIBE CURSOR

The statements in the following examples are assumed to be in PL/I programs.

Example 1

Place information about the result set associated with cursor C1 into the descriptor named by :sqlda1.

```
EXEC SQL DESCRIBE CURSOR C1 INTO :sqlda1
```

Example 2

Place information about the result set associated with the cursor named by :hv1 into the descriptor named by :sqlda2.

```
EXEC SQL DESCRIBE CURSOR :hv1 INTO :sqlda2
```

DESCRIBE INPUT statement

The DESCRIBE INPUT statement obtains information about the input parameter markers of a prepared statement.

For an explanation of prepared statements, see [“PREPARE statement” on page 2042](#).

Invocation for DESCRIBE INPUT

This statement can only be embedded in an application program. It is an executable statement that cannot be dynamically prepared.

Authorization for DESCRIBE INPUT

The statement can be executed if the privilege set for PREPARE includes the EXPLAIN privilege.

Syntax for DESCRIBE INPUT

```
➤ DESCRIBE INPUT — statement-name — INTO — descriptor-name ➤
```

Description for DESCRIBE INPUT

statement-name

Identifies the prepared statement. When the DESCRIBE INPUT statement is executed, the name must identify a statement that has been prepared by the application process at the current server. An input parameter marker must not refer to an array value.

INTO *descriptor-name*

Identifies an SQL descriptor area (SQLDA), which is described in [Appendix G, “SQL descriptor area \(SQLDA\),” on page 2313](#). See [“Identifying an SQLDA in C or C++” on page 2329](#) for how to represent *descriptor-name* in C. The information returned in the SQLDA describes the parameter markers.

Before the DESCRIBE INPUT statement is executed, the user must set the SQLN field in the SQLDA and the SQLDA must be allocated. Considerations for initializing and allocating the SQLDA are similar to those for the DESCRIBE statement (see [“DESCRIBE statement” on page 1869](#)). An occurrence of an extended SQLVAR is needed for each parameter in addition to the required base SQLVAR only if the input data contains LOBs.

For REXX: The SQLDA is not allocated before it is used.

After the DESCRIBE INPUT statement is executed, all the fields in the SQLDA except SQLN are either set by Db2 or ignored. The SQLDA contents are similar to the contents returned for the DESCRIBE statement (see [The SQLDA contents returned after DESCRIBE](#)) with these exceptions:

- In the SQLDAID, Db2 sets the value of the seventh byte only to the space character or '2'. A value of '3' is never used. The value '2' indicates that two SQLVAR entries (an occurrence of both a base SQLVAR and an extended SQLVAR) are required for each parameter because the input data contains LOBs. The seventh byte is a space character when either of the following conditions is true:
 - The input data does not contain LOBs. Only a base SQLVAR occurrence is needed for each parameter.
 - Only a base SQLVAR occurrence is needed for each column of the result, and the SQLDA is not large enough to contain the returned information.
- The SQLD field is set to the number of parameter markers being described. The value is 0 if the statement being described does not have input parameter markers.
- The SQLNAME field is not used.
- The SQLDATATYPE is set to a nullable, regardless of the usage of the parameter markers in the prepared statement.
- The SQLDATATYPE-NAME is not used if an extended SQLVAR entry is present. DESCRIBE INPUT does not return information about distinct types.

For complete information on the contents of the fields, see [Appendix G, “SQL descriptor area \(SQLDA\),” on page 2313](#).

Notes for DESCRIBE INPUT

Preparing the SQLDA for OPEN or EXECUTE: This note is relevant if you are applying DESCRIBE INPUT to a prepared statement and you intend to use the SQLDA in an OPEN or EXECUTE statement. To prepare the SQLDA for that purpose:

- Set SQLDATA to a valid address.
- If SQLTYPE is odd, set SQLIND to a valid address.

For the meaning of those fields in that context, see [Appendix G, “SQL descriptor area \(SQLDA\),” on page 2313](#).

Support for extended dynamic SQL in a distributed environment: Unlike the DESCRIBE statement, which can be used in a distributed environment to describe static SQL statements generated by extended dynamic SQL, you cannot describe host variables in static SQL statements that are generated by extended dynamic SQL. A DESCRIBE INPUT statement issued against such static SQL statements always fails.

For information on how the DESCRIBE statement supports extended dynamic SQL, see [Support for extended dynamic SQL in a distributed environment](#).

Using host variables: If the DESCRIBE INPUT statement contains host variables, the contents of the host variables are assumed to be in the encoding scheme that was specified in the ENCODING parameter when the package or plan that contains the statement was bound.

Example for DESCRIBE INPUT

Execute a DESCRIBE INPUT statement with an SQLDA that has enough SQLVAR occurrences to describe any number of input parameters a prepared statement might have. Assume that five parameter markers at most will need to be described and that the input data does not contain LOBs.

```

/* STMT1_STR contains INSERT statement with VALUES clause */
EXEC SQL PREPARE STMT1_NAME FROM :STMT1_STR;
... /* code to set SQLN to 5 and to allocate the SQLDA */
EXEC SQL DESCRIBE INPUT STMT1_NAME INTO :SQLDA;
.
.
.

```

This example uses the first technique described in [Allocating the SQLDA](#) to allocate the SQLDA.

DESCRIBE OUTPUT statement

The DESCRIBE OUTPUT statement obtains information about a prepared statement.

For an explanation of prepared statements, see [“PREPARE statement” on page 2042](#).

Invocation for DESCRIBE OUTPUT

This statement can only be embedded in an application program. It is an executable statement that cannot be dynamically prepared. It must not be specified in Java.

Authorization for DESCRIBE OUTPUT

The statement can be executed if the privilege set for PREPARE includes the EXPLAIN privilege.

See [“PREPARE statement” on page 2042](#) for the authorization required to create a prepared statement.

Syntax for DESCRIBE OUTPUT

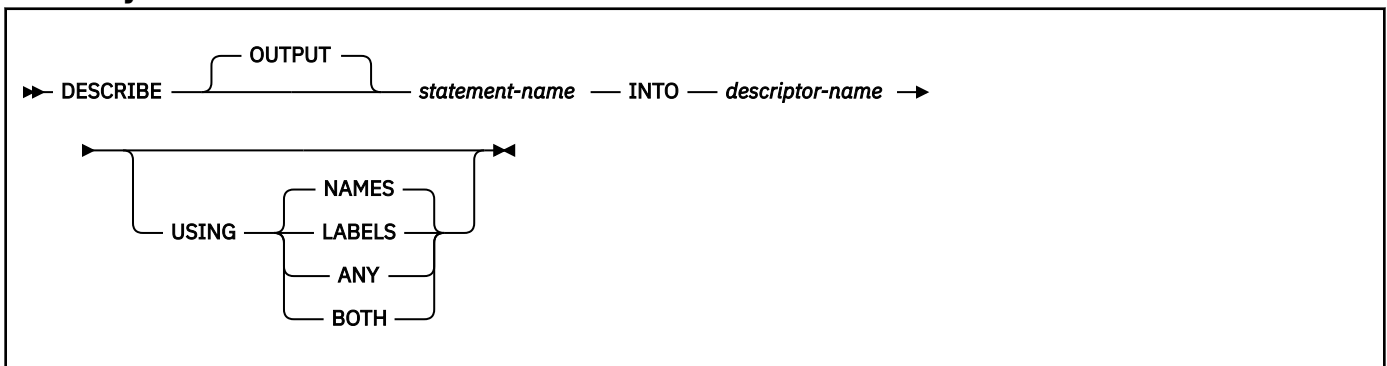

Description for DESCRIBE OUTPUT

OUTPUT

When a *statement-name* is specified, optional keyword to indicate that the describe will return information about the select list columns in a the prepared SELECT statement.

statement-name

Identifies the prepared statement. When the DESCRIBE statement is executed, the name must identify a statement that has been prepared by the application process at the current server. A column of the result table of the prepared statement must not be an array.

INTO *descriptor-name*

Identifies an SQL descriptor area (SQLDA), which is described in [Appendix G, “SQL descriptor area \(SQLDA\),” on page 2313](#). See [“Identifying an SQLDA in C or C++” on page 2329](#) for how to represent *descriptor-name* in C.

For languages other than REXX: Before the DESCRIBE statement is executed, the user must set the following variable in the SQLDA and the SQLDA must be allocated.

SQLN

Indicates the number of SQLVAR occurrences provided in the SQLDA. Db2 does not change this value. For techniques to determine the number of required occurrences, see [Allocating the SQLDA](#).

For REXX: The SQLDA is not allocated before it is used. An SQLDA consists of a set of stem variables. There is one occurrence of variable *stem.SQLD*, followed by zero or more occurrences of a set of variables that is equivalent to an SQLVAR structure. Those variables begin with *stem.n*.

After the DESCRIBE statement is executed, all the fields in the SQLDA except SQLN are either set by Db2 or ignored. For information on the contents of the fields, see [The SQLDA contents returned after DESCRIBE](#).

USING

Indicates what value to assign to each SQLNAME variable in the SQLDA. If the requested value does not exist, SQLNAME is set to a length of 0.

NAMES

Assigns the name of the column. This is the default.

LABELS

Assigns the label of the column. (Column labels are defined by the LABEL statement.)

ANY

Assigns the label of the column. If the column has no label or the label is a string of length 0, the column name is used instead.

BOTH

Assigns both the label and name of the column. In this case, two or three occurrences of SQLVAR per column, depending on whether the result set contains distinct types, are needed to accommodate the additional information. To specify this expansion of the SQLVAR array, set SQLN to $2 \times n$ or $3 \times n$, where n is the number of columns in the object being described. For each of the columns, the first n occurrences of SQLVAR, which are the base SQLVAR entries, contain the column names. Either the second or third n occurrences of SQLVAR, which are the extended SQLVAR entries, contain the column labels. If there are no distinct types, the labels are returned in the second set of SQLVAR entries. Otherwise, the labels are returned in the third set of SQLVAR entries.

Notes for DESCRIBE OUTPUT

Using PREPARE INTO clause:

Information about a prepared statement can also be obtained by using the INTO clause of the PREPARE statement.

Allocating the SQLDA:

Before the DESCRIBE or PREPARE INTO statement is executed, the value of SQLN must be set to a value greater than or equal to zero to indicate how many occurrences of SQLVAR are provided in the SQLDA. Also, enough storage must be allocated to contain the number of occurrences that SQLN specifies. To obtain the description of the columns of the result table of a prepared SELECT statement, the number of occurrences of SQLVAR must be at least equal to the number of columns. Furthermore, if USING BOTH is specified, or if the columns include LOBs or distinct types, the number of occurrences of SQLVAR should be two or three times the number of columns. See [“Determining how many SQLVAR occurrences are needed” on page 2316](#) for more information.

First technique

Allocate an SQLDA with enough occurrences of SQLVAR to accommodate any select list that the application will have to process. At the extreme, the number of SQLVARs could equal three times the maximum number of columns allowed in a result table. After the SQLDA is allocated, the application can use the SQLDA repeatedly.

This technique uses a large amount of storage that is never deallocated, even when most of this storage is not used for a particular select list.

Second technique

Repeat the following two steps for every processed select list:

1. Execute a DESCRIBE statement with an SQLDA that has no occurrences of SQLVAR; that is, an SQLDA for which SQLN is zero.
2. Allocate a new SQLDA with enough occurrences of SQLVAR. Use the values that are returned in SQLD and SQLCODE to determine the number of SQLVAR entries that are needed. The value of SQLD is the number of columns in the result table, which is either the required number of occurrences of SQLVAR or a fraction of the required number (see [“Determining how many SQLVAR occurrences are needed” on page 2316](#) for details). If the SQLCODE is +236, +237, +238, or +239, the number of SQLVAR entries that is needed is two or three times the value

in SQLD, depending on whether USING BOTH was specified. Set SQLN to reflect the number of SQLVAR entries that have been allocated.

3. Execute the DESCRIBE statement again, u

This technique allows better storage management than the first technique, but it doubles the number of DESCRIBE statements.

sing the new SQLDA.

Third technique

Allocate an SQLDA that is large enough to handle most (hopefully, all) select lists but is also reasonably small. If an execution of DESCRIBE fails because SQLDA is too small, allocate a larger SQLDA and execute the DESCRIBE statement again.

For the new larger SQLDA, use the values that are returned in SQLD and SQLCODE from the failing DESCRIBE statement to calculate the number of occurrences of SQLVAR that are needed, as described in technique two. Remember to check for SQLCODEs +236, +237, +238, and +239, which indicate whether *extended* SQLVAR entries are needed because the data includes LOBs or distinct types.

This third technique is a compromise between the first two techniques. Its effectiveness depends on a good choice of size for the original SQLDA.

SQLDA contents returned on DESCRIBE:

After a DESCRIBE statement is executed, the following list describes the contents of the SQLDA fields as they are set by Db2 or ignored. These descriptions do not necessarily apply to the uses of an SQLDA in other SQL statements (EXECUTE, OPEN, FETCH). For more on the other uses, see [Appendix G, "SQL descriptor area \(SQLDA\)," on page 2313](#).

SQLDAID

Db2 sets the first 6 bytes to 'SQLDA ' (5 letters followed by the space character) and the eighth byte to a space character. The seventh byte is set to indicate the number of SQLVAR entries that are needed to describe each column of the result table as follows:

space

The value of space occurs when:

- USING BOTH was not specified and the columns being described do not include LOBs or distinct types. Each column only needs one SQLVAR entry. If the SQL standard option is yes, Db2 sets SQLCODE to warning code +236. Otherwise, SQLCODE is zero.
- USING BOTH was specified and the columns being described do not include LOBs or distinct types. Each column needs two SQLVAR entries. Db2 sets SQLD to two times the number of columns of the result table. The second set of SQLVARs is used for the labels.

2

Each column needs two SQLVAR entries. Two entries per column are required when:

- USING BOTH was not specified and the columns being described include LOBs or distinct types or both. Db2 sets the second set of SQLVAR entries with information for the LOBs or distinct types being described.
- USING BOTH was specified and the columns include LOBs but not distinct types. Db2 sets the second set of SQLVAR entries with information for the LOBs and labels for the columns being described.

3

Each column needs three SQLVAR entries. Three entries are required only when USING BOTH is specified and the columns being described include distinct types. The presence of LOB data does not matter. It is the distinct types and not the LOBs that cause the need for three SQLVAR entries per column when labels are also requested. Db2 sets the second set of SQLVAR entries with information for the distinct types (and LOBs, if any) and the third set of SQLVAR entries with the labels of the columns being described.

A REXX SQLDA does not contain this field.

SQLDABC

The length of the SQLDA in bytes. Db2 sets the value to $SQLN \times 44 + 16$.

A REXX SQLDA does not contain this field.

SQLD

If the prepared statement is a query, Db2 sets the value to the number of columns in the object being described. (For languages other than REXX, in the case where USING BOTH was specified and the result table does not include LOBs or distinct types, the value is actually twice the number of columns. For REXX, if USING BOTH is specified, the value is twice the number of columns, regardless of whether the result table include LOBs or distinct types.) Otherwise, if the statement is not a query, Db2 sets the value to 0.

SQLVAR

An array of field description information for the column being described. There are two types of SQLVAR entries—the base SQLVAR and the extended SQLVAR.

If the value of SQLD is 0, or is greater than the value of SQLN, no values are assigned to any occurrences of SQLVAR. If the value of SQLN was set so that there are enough SQLVAR occurrences to describe the specified columns (columns with LOBs or distinct types and a request for labels increase the number of SQLVAR entries that are needed), the values are assigned to the first n occurrences of SQLVAR so that the first occurrence of SQLVAR contains a description of the first column, the second occurrence of SQLVAR contains a description of the second column, and so on. This first set of SQLVAR entries are referred to as *base SQLVAR* entries. Each column always has a base SQLVAR entry.

If the DESCRIBE statement included the USING BOTH clause, or the columns being described include LOBs or distinct types, additional SQLVAR entries are needed. These additional SQLVAR entries are referred to as the *extended SQLVAR* entries. There can be up to two sets of extended SQLVAR entries for each column.

For REXX, the SQLVAR is a set of stem variables that begin with *stem.n*, instead of a structure. The REXX SQLDA uses only a base SQLVAR. However, REXX uses the way in which Db2 assigns values to the SQLVAR variables is the same as for other languages. That is, the *stem.1* variables describe the first column in the result table, the *stem.2* variables describe the second column in the result table, and so on. If USING BOTH is specified, the *stem+1* variables also describe the first column in the result table, the *stem.n+2* variables also describe the second column in the result table, and so on.

The base SQLVAR:

SQLTYPE

A code that indicates the data type of the column and whether the column can contain null values. For the possible values of SQLTYPE, see [“SQLTYPE and SQLLEN” on page 2322](#).

SQLLEN

A length value depending on the data type of the result columns. SQLLEN is 0 for LOB and XML data types. For the other possible values of SQLLEN, see [“SQLTYPE and SQLLEN” on page 2322](#).

In a REXX SQLDA, for DECIMAL or NUMERIC columns, Db2 sets the SQLPRECISION and SQLSCALE fields instead of the SQLLEN field.

SQLDATA

The CCSID of a string column. For possible values, see [“SQLDATA” on page 2325](#).

In a REXX SQLDA, Db2 sets the SQLCCSID field instead of the SQLDATA field.

SQLIND

Reserved.

SQLNAME

The unqualified name or label of the column, depending on the value of USING (NAMES, LABELS, ANY, or BOTH). The field is a string of length 0 if the column does not have a name or label. For more details on unnamed columns, see the discussion of the names of result

columns under “select-clause” on page 1010. This value is returned in the encoding scheme specified by the ENCODING bind option for the plan or package that contains the statement.

SQLLONGL

For REXX only, the length attribute of a LOB column. Other languages use SQLLONGLEN in the extended SQLVAR.

SQLCCSID

For REXX only, the length attribute of a LOB column.

SQLTNAME

For REXX only, the fully qualified distinct type name of the *n*th column in the result table. Other languages use SQLDATATYPE-NAME in the extended SQLVAR.

The extended SQLVAR:**SQLLONGLEN**

The length attribute of a BLOB, CLOB, or DBCLOB column.

*

Reserved.

SQLDATALEN

Not Used.

SQLDATATYPE-NAME

For a distinct type, the fully qualified distinct type name. Otherwise, the value is the fully qualified name of the built-in data type.

For a label, the label for the column.

This value is returned in the encoding scheme specified by the ENCODING bind option for the plan or package that contains this statement.

Performance considerations:

Although Db2 does not change the value of SQLN, you might want to reset this value after the DESCRIBE statement is executed. If the contents of SQLDA from the DESCRIBE statement is used in a later FETCH statement, set SQLN to *n* (where *n* is the number of columns of the result table) before executing the FETCH statement. For details, see [Preparing the SQLDA for data retrieval](#)

Preparing the SQLDA for data retrievals

This note is relevant if you are applying DESCRIBE to a prepared query and you intend to use the SQLDA in the FETCH statements you employ to retrieve the result table rows. To prepare the SQLDA for that task, you must set the SQLDATA field of SQLVAR. SQLIND must be set if SQLTYPE is odd, and SQLNAME must be set when overriding the CCSID. For the meaning of those fields in that context, see [Appendix G, “SQL descriptor area \(SQLDA\),” on page 2313.](#)

Also, SQLN and SQLDABC should be reset (if necessary) to *n* and $n \times 44 + 16$, where *n* is the number of columns in the result table. Doing so can improve performance when the rows of the result table are fetched.

Support for extended dynamic SQL in a distributed environment:

In a distributed environment where Db2 for z/OS is the server and the requester supports extended dynamic SQL, such as Db2 server for VSE and VM, a DESCRIBE statement that is executed against an SQL statement in the extended dynamic package appears to Db2 as a DESCRIBE statement against a static SQL statement in the Db2 package. A DESCRIBE statement cannot normally be issued against a static SQL statement. However, a DESCRIBE against a static SQL statement that is generated by extended dynamic SQL executes without error if the package has been rebound after field DESCRIBE FOR STATIC on installation panel DSNTIP4 has been set to YES.

YES indicates that Db2 generates an SQLDA for the DESCRIBE at bind time so that DESCRIBE requests for static SQL statements can be satisfied at execution time. For more information, see [DESCRIBE FOR STATIC field \(DESCSTAT subsystem parameter\) \(Db2 Installation and Migration\).](#)

Avoiding double preparation when using REOPT(ALWAYS) or REOPT(ONCE):

If bind option REOPT(ALWAYS) or REOPT(ONCE) is in effect, DESCRIBE causes the statement to be prepared if it is not already prepared. If issued before an OPEN or an EXECUTE, the DESCRIBE causes the statement to be prepared without input variables. If the statement has input variables, the statement must be prepared again when it is opened or executed. When REOPT(ONCE) is in effect, the statement is always prepared twice even if there are no input variables. Therefore, to avoid preparing statements twice, issue the DESCRIBE after the OPEN. For non-cursor statements, open and fetch processing are performed on the EXECUTE. So, if a DESCRIBE must be issued, the statement will be prepared twice.

The use of a prepared statement for an EXPLAIN statement can cause duplicate entries in the explain tables when the prepared statement specifies the REOPT(ALWAYS) bind option and is executed using the jcc driver.

Errors occurring on DESCRIBE:

In local and remote processing, the DEFER(PREPARE) and REOPT(ALWAYS)/REOPT(ONCE) bind options can cause some errors that are normally issued during PREPARE processing to be issued on DESCRIBE.

Considerations for implicitly hidden columns:

A DESCRIBED OUTPUT statement only returns information about implicitly hidden columns if the column (of a base table that is defined as implicitly hidden) is explicitly specified as part of the SELECT list of the final result table of the query described. If implicitly hidden columns are not part of the result table of a query, a DESCRIBE OUTPUT statement that returns information about that query will not contain information about any implicitly hidden columns.

Using host variables:

If the DESCRIBE statement contains host variables, the contents of the host variables are assumed to be in the encoding scheme that was specified in the ENCODING parameter when the package or plan that contains the statement was bound.

Considerations for array elements:

CCSID UNICODE is returned for a result column that corresponds to a reference to an array element with a datetime data type.

Example for DESCRIBE OUTPUT

In a PL/I program, execute a DESCRIBE statement with an SQLDA that has no occurrences of SQLVAR. If SQLD is greater than zero, use the value to allocate an SQLDA with the necessary number of occurrences of SQLVAR and then execute a DESCRIBE statement using that SQLDA.

```
EXEC SQL BEGIN DECLARE SECTION;
      DCL STMT1_STR CHAR(200) VARYING;
EXEC SQL END DECLARE SECTION;
EXEC SQL INCLUDE SQLDA;
EXEC SQL DECLARE DYN_CURSOR CURSOR FOR STMT1_NAME;
... /* code to prompt user for a query, then to generate */
      /* a select-statement in the STMT1_STR */
EXEC SQL PREPARE STMT1_NAME FROM :STMT1_STR;
... /* code to set SQLN to zero and to allocate the SQLDA */
EXEC SQL DESCRIBE STMT1_NAME INTO :SQLDA;
... /* code to check that SQLD is greater than zero, to set */
      /* SQLN to SQLD, then to re-allocate the SQLDA */
EXEC SQL DESCRIBE STMT1_NAME INTO :SQLDA;
... /* code to prepare for the use of the SQLDA */
EXEC SQL OPEN DYN_CURSOR;
... /* loop to fetch rows from result table */
EXEC SQL FETCH DYN_CURSOR USING DESCRIPTOR :SQLDA;
.
.
.
```

DESCRIBE PROCEDURE statement

The DESCRIBE PROCEDURE statement gets information about the result sets returned by a stored procedure. The information, such as the number of result sets, is put into a descriptor.

Invocation for DESCRIBE PROCEDURE

This statement can only be embedded in an application program. It is an executable statement that cannot be dynamically prepared.

Authorization for DESCRIBE PROCEDURE

None required.

Syntax for DESCRIBE PROCEDURE

```
▶ DESCRIBE PROCEDURE procedure-name INTO descriptor-name ▶  
                    host-variable
```

Description for DESCRIBE PROCEDURE

procedure-name or *host-variable*

Identifies the stored procedure that returned one or more result sets. When the DESCRIBE PROCEDURE statement is executed, the procedure name must identify a stored procedure that the requester has already invoked using the SQL CALL statement. The procedure name can be specified as a one, two, or three-part name. The procedure name in the DESCRIBE PROCEDURE statement must be specified the same way that it was specified on the CALL statement. For example, if a two-part procedure name was specified on the CALL statement, you must specify a two-part procedure name in the DESCRIBE PROCEDURE statement.

If a host variable is used:

- It must be a character string variable with a length attribute that is not greater than 254.
- It must not be followed by an indicator variable.
- The value of the host variable is a specification that depends on the database server. Regardless of the server, the specification must:
 - Be left justified within the host variable
 - Not contain embedded blanks
 - Be padded on the right with blanks if its length is less than that of the host variable

Exception: The syntax described above applies to all languages except REXX. For REXX, the syntax is DESCRIBE PROCEDURE *:hostvar*.

INTO *descriptor-name*

Identifies an SQL descriptor area (SQLDA). The information returned in the SQLDA describes the result sets returned by the stored procedure.

Considerations for allocating and initializing the SQLDA are similar to those for DESCRIBE TABLE.

The contents of the SQLDA after executing a DESCRIBE PROCEDURE statement are:

- The first 5 bytes of the SQLDAID field are set to 'SQLPR'.
A REXX SQLDA does not contain SQLDAID.
- Bytes 6 to 8 of the SQLDAID field are reserved.
- The SQLD field is set to the total number of result sets. A value of 0 in the field indicates there are no result sets.

- There is one SQLVAR entry for each result set.
- The SQLDATA field of each SQLVAR entry is set to the result set locator value associated with the result set.
For a REXX SQLDA, SQLLOCATOR is set to the result set locator value.
- The SQLIND field of each SQLVAR entry is set to the estimated number of rows in the result set
For a REXX SQLDA, the SQLIND field is not used for DESCRIBE.
- The SQLNAME field is set to the name of the cursor used by the stored procedure to return the result set. This value is returned in the encoding scheme specified by the ENCODING bind option for the plan or package that contains this statement.

Notes for DESCRIBE PROCEDURE

SQLDA information: A value of -1 in the SQLIND field indicates that an estimated number of rows in the result set is not provided. Db2 for z/OS always sets SQLIND to -1. For a REXX SQLDA, the SQLIND field is not used for DESCRIBE.

DESCRIBE PROCEDURE does not return information about the parameters expected by the stored procedure.

Assignment of locator values: Locator values are assigned to the SQLVAR entries in the SQLDA in the order that the associated cursors are opened at run time. Locator values are not provided for cursors that are closed when control is returned to the invoking application. If a cursor was closed and later re-opened before returning to the invoking application, the most recently executed OPEN CURSOR statement for the cursor is used to determine the order in which the locator values are returned for the procedure result sets. For example, assume procedure P1 opens three cursors A, B, C, closes cursor B and then issues another OPEN CURSOR statement for cursor B before returning to the invoking application. The locator values are assigned in the order A, C, B.

Alternatively, an ASSOCIATE LOCATORS statement can be used to copy the locator values to result set locator variables.

Using host variables: If the DESCRIBE PROCEDURE statement contains host variables, the contents of the host variables are assumed to be in the encoding scheme that was specified in the ENCODING parameter when the package or plan that contains the statement was bound.

Examples for DESCRIBE PROCEDURE

The statements in the following examples are assumed to be in PL/I programs.

Example 1: Place information about the result sets returned by stored procedure P1 into the descriptor named by SQLDA1. Assume that the stored procedure is called with a one-part name from current server SITE2.

```
EXEC SQL CONNECT TO SITE2;
EXEC SQL CALL P1;
EXEC SQL DESCRIBE PROCEDURE P1 INTO :SQLDA1;
```

Example 2: Repeat the scenario in Example 1, but use a two-part name to specify an explicit schema name for the stored procedure to ensure that stored procedure P1 in schema MYSCHEMA is used.

```
EXEC SQL CONNECT TO SITE2;
EXEC SQL CALL MYSCHEMA.P1;
EXEC SQL DESCRIBE PROCEDURE MYSCHEMA.P1 INTO :SQLDA1;
```

Example 3: Place information about the result sets returned by the stored procedure identified by host variable HV1 into the descriptor named by SQLDA2. Assume that host variable HV1 contains the value SITE2.MYSCHEMA.P1 and the stored procedure is called with a three-part name.

```
EXEC SQL CALL SITE2.MYSCHEMA.P1;  
EXEC SQL DESCRIBE PROCEDURE :HV1 INTO :SQLDA2;
```

The preceding example would be invalid if host variable HV1 had contained the value MYSCHEMA.P1, a two-part name. For the example to be valid with that two-part name in host variable HV1, the current server must be the same as the location name that is specified on the CALL statement as the following statements demonstrate. This is the only condition under which the names do not have to be specified the same way and a three-part name on the CALL statement can be used with a two-part name on the DESCRIBE PROCEDURES statement.

```
EXEC SQL CONNECT TO SITE2;  
EXEC SQL CALL SITE2.MYSCHEMA.P1;  
EXEC SQL ASSOCIATE LOCATORS (:LOC1, :LOC2)  
WITH PROCEDURE :HV1;
```

DESCRIBE TABLE statement

The DESCRIBE TABLE statement obtains information about a designated table or view.

Invocation for DESCRIBE TABLE

This statement can only be embedded in an application program. It is an executable statement that cannot be dynamically prepared. It must not be specified in Java.

Authorization for DESCRIBE TABLE

The privileges that are held by the authorization ID that owns the plan or package must include at least one of the following (if there is a plan, authorization checking is done only against the plan owner):

- Ownership of the table or view
- The SELECT, INSERT, UPDATE, DELETE, or REFERENCES privilege on the object
- The ALTER or INDEX privilege on the object (tables only)
- DBADM authority over the database that contains the object (tables only)
- SYSADM authority
- SYSCTRL authority (catalog tables only)
- ACCESSCTRL authority (catalog tables only)
- System DBADM
- DATAACCESS authority
- EXPLAIN authority
- SQLADM authority

If the database is implicitly created, the database privileges must be on the implicit database or on DSNDBO4.

For an RRSAP application that does not have a plan and in which the requester and the server are Db2 for z/OS systems, authorization to execute the package is performed against the primary or secondary authorization ID of the process.

Syntax for DESCRIBE TABLE

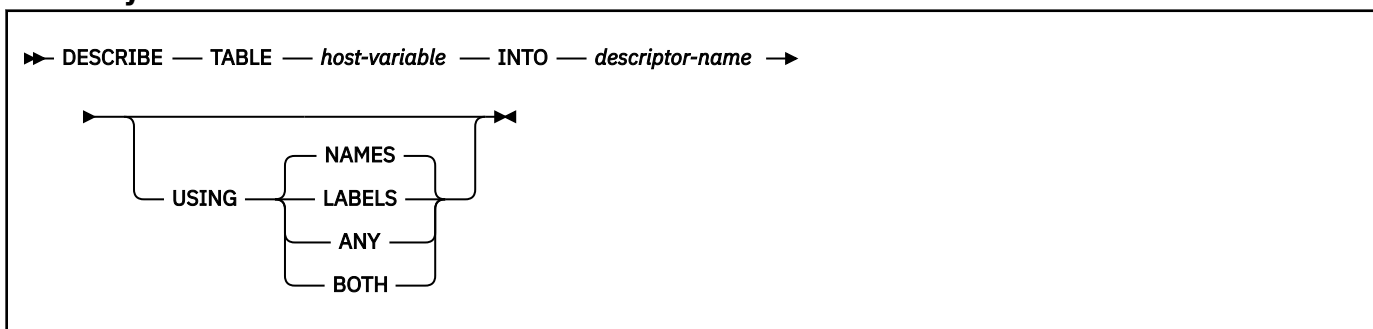

Description for DESCRIBE TABLE

TABLE *host-variable*

Identifies the table or view. The name must not identify an auxiliary table. When the DESCRIBE statement is executed, the host variable must contain a name which identifies a table or view that exists at the current server. This variable must be a fixed-length or varying-length character string with a length attribute less than 256. The name must be followed by one or more blanks if the length of the name is less than the length of the variable. It cannot contain a period as the first character and it cannot contain embedded blanks. In addition, the quotation mark is the escape character regardless of the value of the string delimiter option. An indicator variable must not be specified for the host variable.

INTO *descriptor-name*

Identifies an SQL descriptor area (SQLDA), which is described in Appendix G, “SQL descriptor area (SQLDA),” on page 2313. See “Identifying an SQLDA in C or C++” on page 2329 for how to represent *descriptor-name* in C.

For languages other than REXX: Before the DESCRIBE statement is executed, the user must set the following variable in the SQLDA and the SQLDA must be allocated.

SQLN

Indicates the number of SQLVAR occurrences provided in the SQLDA. Db2 does not change this value. For techniques to determine the number of required occurrences, see *Allocating the SQLDA*.

For REXX: The SQLDA is not allocated before it is used. An SQLDA consists of a set of stem variables. There is one occurrence of variable *stem.SQLD*, followed by zero or more occurrences of a set of variables that is equivalent to an SQLVAR structure. Those variables begin with *stem.n*.

After the DESCRIBE statement is executed, all the fields in the SQLDA except SQLN are either set by Db2 or ignored. For information on the contents of the fields, see *The SQLDA contents returned after DESCRIBE*.

USING

Indicates what value to assign to each SQLNAME variable in the SQLDA. If the requested value does not exist, SQLNAME is set to a length of 0.

NAMES

Assigns the name of the column. This is the default.

LABELS

Assigns the label of the column. (Column labels are defined by the LABEL statement.)

ANY

Assigns the label of the column. If the column has no label or the label is a string of length 0, the column name is used instead.

BOTH

Assigns both the label and name of the column. In this case, two or three occurrences of SQLVAR per column, depending on whether the result set contains distinct types, are needed to accommodate the additional information. To specify this expansion of the SQLVAR array, set SQLN to $2xn$ or $3xn$, where n is the number of columns in the object being described. For each

of the columns, the first n occurrences of SQLVAR, which are the base SQLVAR entries, contain the column names. Either the second or third n occurrences of SQLVAR, which are the extended SQLVAR entries, contain the column labels. If there are no distinct types, the labels are returned in the second set of SQLVAR entries. Otherwise, the labels are returned in the third set of SQLVAR entries.

For a declared temporary table, the name of the column is assigned regardless of the value specified in the USING clause because declared temporary tables cannot have labels.

Notes for DESCRIBE TABLE

Allocating the SQLDA:

Before the DESCRIBE or PREPARE INTO statement is executed, the value of SQLN must be set to a value greater than or equal to zero to indicate how many occurrences of SQLVAR are provided in the SQLDA. Also, enough storage must be allocated to contain the number of occurrences that SQLN specifies. To obtain the description of the columns of the result table of a prepared SELECT statement, the number of occurrences of SQLVAR must be at least equal to the number of columns. Furthermore, if USING BOTH is specified, or if the columns include LOBs or distinct types, the number of occurrences of SQLVAR should be two or three times the number of columns. See [“Determining how many SQLVAR occurrences are needed” on page 2316](#) for more information.

First technique

Allocate an SQLDA with enough occurrences of SQLVAR to accommodate any select list that the application will have to process. At the extreme, the number of SQLVARs could equal three times the maximum number of columns allowed in a result table. After the SQLDA is allocated, the application can use the SQLDA repeatedly.

This technique uses a large amount of storage that is never deallocated, even when most of this storage is not used for a particular select list.

Second technique

Repeat the following two steps for every processed select list:

1. Execute a DESCRIBE statement with an SQLDA that has no occurrences of SQLVAR; that is, an SQLDA for which SQLN is zero.
2. Allocate a new SQLDA with enough occurrences of SQLVAR. Use the values that are returned in SQLD and SQLCODE to determine the number of SQLVAR entries that are needed. The value of SQLD is the number of columns in the result table, which is either the required number of occurrences of SQLVAR or a fraction of the required number (see [“Determining how many SQLVAR occurrences are needed” on page 2316](#) for details). If the SQLCODE is +236, +237, +238, or +239, the number of SQLVAR entries that is needed is two or three times the value in SQLD, depending on whether USING BOTH was specified. Set SQLN to reflect the number of SQLVAR entries that have been allocated.
3. Execute the DESCRIBE statement again, u

This technique allows better storage management than the first technique, but it doubles the number of DESCRIBE statements.

sing the new SQLDA.

Third technique

Allocate an SQLDA that is large enough to handle most (hopefully, all) select lists but is also reasonably small. If an execution of DESCRIBE fails because SQLDA is too small, allocate a larger SQLDA and execute the DESCRIBE statement again.

For the new larger SQLDA, use the values that are returned in SQLD and SQLCODE from the failing DESCRIBE statement to calculate the number of occurrences of SQLVAR that are needed, as described in technique two. Remember to check for SQLCODEs +236, +237, +238, and +239, which indicate whether *extended* SQLVAR entries are needed because the data includes LOBs or distinct types.

This third technique is a compromise between the first two techniques. Its effectiveness depends on a good choice of size for the original SQLDA.

SQLDA contents returned on DESCRIBE:

After a DESCRIBE statement is executed, the following list describes the contents of the SQLDA fields as they are set by Db2 or ignored. These descriptions do not necessarily apply to the uses of an SQLDA in other SQL statements (EXECUTE, OPEN, FETCH). For more on the other uses, see [Appendix G, "SQL descriptor area \(SQLDA\),"](#) on page 2313.

SQLDAID

Db2 sets the first 6 bytes to 'SQLDA ' (5 letters followed by the space character) and the eighth byte to a space character. The seventh byte is set to indicate the number of SQLVAR entries that are needed to describe each column of the result table as follows:

space

The value of space occurs when:

- USING BOTH was not specified and the columns being described do not include LOBs or distinct types. Each column only needs one SQLVAR entry. If the SQL standard option is yes, Db2 sets SQLCODE to warning code +236. Otherwise, SQLCODE is zero.
- USING BOTH was specified and the columns being described do not include LOBs or distinct types. Each column needs two SQLVAR entries. Db2 sets SQLD to two times the number of columns of the result table. The second set of SQLVARs is used for the labels.

2

Each column needs two SQLVAR entries. Two entries per column are required when:

- USING BOTH was not specified and the columns being described include LOBs or distinct types or both. Db2 sets the second set of SQLVAR entries with information for the LOBs or distinct types being described.
- USING BOTH was specified and the columns include LOBs but not distinct types. Db2 sets the second set of SQLVAR entries with information for the LOBs and labels for the columns being described.

3

Each column needs three SQLVAR entries. Three entries are required only when USING BOTH is specified and the columns being described include distinct types. The presence of LOB data does not matter. It is the distinct types and not the LOBs that cause the need for three SQLVAR entries per column when labels are also requested. Db2 sets the second set of SQLVAR entries with information for the distinct types (and LOBs, if any) and the third set of SQLVAR entries with the labels of the columns being described.

A REXX SQLDA does not contain this field.

SQLDABC

The length of the SQLDA in bytes. Db2 sets the value to $SQLN \times 44 + 16$.

A REXX SQLDA does not contain this field.

SQLD

If the prepared statement is a query, Db2 sets the value to the number of columns in the object being described. (For languages other than REXX, in the case where USING BOTH was specified and the result table does not include LOBs or distinct types, the value is actually twice the number of columns. For REXX, if USING BOTH is specified, the value is twice the number of columns, regardless of whether the result table include LOBs or distinct types.) Otherwise, if the statement is not a query, Db2 sets the value to 0.

SQLVAR

An array of field description information for the column being described. There are two types of SQLVAR entries—the base SQLVAR and the extended SQLVAR.

If the value of SQLD is 0, or is greater than the value of SQLN, no values are assigned to any occurrences of SQLVAR. If the value of SQLN was set so that there are enough SQLVAR

occurrences to describe the specified columns (columns with LOBs or distinct types and a request for labels increase the number of SQLVAR entries that are needed), the values are assigned to the first *n* occurrences of SQLVAR so that the first occurrence of SQLVAR contains a description of the first column, the second occurrence of SQLVAR contains a description of the second column, and so on. This first set of SQLVAR entries are referred to as *base SQLVAR* entries. Each column always has a base SQLVAR entry.

If the DESCRIBE statement included the USING BOTH clause, or the columns being described include LOBs or distinct types, additional SQLVAR entries are needed. These additional SQLVAR entries are referred to as the *extended SQLVAR* entries. There can be up to two sets of extended SQLVAR entries for each column.

For REXX, the SQLVAR is a set of stem variables that begin with *stem.n*, instead of a structure. The REXX SQLDA uses only a base SQLVAR. However, REXX uses the way in which Db2 assigns values to the SQLVAR variables is the same as for other languages. That is, the *stem.1* variables describe the first column in the result table, the *stem.2* variables describe the second column in the result table, and so on. If USING BOTH is specified, the *stem+1* variables also describe the first column in the result table, the *stem.n+2* variables also describe the second column in the result table, and so on.

The base SQLVAR:

SQLTYPE

A code that indicates the data type of the column and whether the column can contain null values. For the possible values of SQLTYPE, see [“SQLTYPE and SQLLEN” on page 2322](#).

SQLLEN

A length value depending on the data type of the result columns. SQLLEN is 0 for LOB and XML data types. For the other possible values of SQLLEN, see [“SQLTYPE and SQLLEN” on page 2322](#).

In a REXX SQLDA, for DECIMAL or NUMERIC columns, Db2 sets the SQLPRECISION and SQLSCALE fields instead of the SQLLEN field.

SQLDATA

The CCSID of a string column. For possible values, see [“SQLDATA” on page 2325](#).

In a REXX SQLDA, Db2 sets the SQLCCSID field instead of the SQLDATA field.

SQLIND

Reserved.

SQLNAME

The unqualified name or label of the column, depending on the value of USING (NAMES, LABELS, ANY, or BOTH). The field is a string of length 0 if the column does not have a name or label. For more details on unnamed columns, see the discussion of the names of result columns under [“select-clause” on page 1010](#). This value is returned in the encoding scheme specified by the ENCODING bind option for the plan or package that contains the statement.

SQLLONGL

For REXX only, the length attribute of a LOB column. Other languages use SQLLONGLEN in the extended SQLVAR.

SQLCCSID

For REXX only, the length attribute of a LOB column.

SQLTNAME

For REXX only, the fully qualified distinct type name of the *n*th column in the result table. Other languages use SQLDATATYPE-NAME in the extended SQLVAR.

The extended SQLVAR:

SQLLONGLEN

The length attribute of a BLOB, CLOB, or DBCLOB column.

*

Reserved.

SQLDATALEN

Not Used.

SQLDATATYPE-NAME

For a distinct type, the fully qualified distinct type name. Otherwise, the value is the fully qualified name of the built-in data type.

For a label, the label for the column.

This value is returned in the encoding scheme specified by the ENCODING bind option for the plan or package that contains this statement.

Performance considerations:

Although Db2 does not change the value of SQLN, you might want to reset this value after the DESCRIBE statement is executed. If the contents of SQLDA from the DESCRIBE statement is used in a later FETCH statement, set SQLN to n (where n is the number of columns of the result table) before executing the FETCH statement. For details, see [Preparing the SQLDA for data retrieval](#)

Using host variables:

If the DESCRIBE statement contains host variables, the contents of the host variables are assumed to be in the encoding scheme that was specified in the ENCODING parameter when the package or plan that contains the statement was bound.

Considerations for implicitly hidden columns:

A DESCRIBE TABLE statement does return information about implicitly hidden columns in tables.

DROP statement

The DROP statement removes an object at the current server. Except for storage groups, any objects that are directly or indirectly dependent on that object are also removed. Whenever an object is dropped, its description is deleted from the catalog at the current server, and any packages that refer to the object are invalidated.

Invocation for DROP

This statement can be embedded in an application program or issued interactively. It is an executable statement that can be dynamically prepared only if DYNAMICRULES RUN behavior is in effect. For more information, see [“Authorization IDs and dynamic SQL” on page 94](#).

Authorization for DROP

To drop the following objects, the privilege set must include at least one of the listed authorities or privileges:

Table, table space, or index:

- Ownership of the object (for an index, the owner is the owner of the table or index)
- DBADM authority
- SYSADM or SYSCTRL authority
- System DBADM
- Installation SYSOPR authority (when the current SQLID of the process is set to SYSINSTL)

If the table space is in a database that is implicitly created, the database privileges must be on the implicit database or on DSNDB04.

Database:

- The DROP privilege on the database
- DBADM or DBCTRL authority for the database
- SYSADM or SYSCTRL authority
- System DBADM

- Installation SYSOPR authority (when the current SQLID of the process is set to SYSINSTL)

If the database is implicitly created, the privileges must be on the implicit database or on DSNDB04.

Storage group:

- Ownership of the object
- SYSADM or SYSCTRL authority
- Installation SYSOPR authority (when the current SQLID of the process is set to SYSINSTL)

View:

- Ownership of the object
- SYSADM or SYSCTRL authority
- System DBADM authority

Alias for a table or view:

- Ownership of the object
- SYSADM or SYSCTRL authority
- System DBADM

Alias for a sequence:

- Ownership of the object
- The DROPIN privilege on the schema
- SYSADM or SYSCTRL authority
- System DBADM

Package:

- Ownership of the package
- The BINDAGENT privilege granted from the package owner
- PACKADM authority for the collection or for all collections
- SYSADM or SYSCTRL authority

Synonym:

Ownership of the synonym

Role or trusted context:

- Ownership of the object
- SYSADM or SYSCTRL authority
- SECADM

If the installation parameter SEPARATE SECURITY is NO, SYSADM authority has implicit SECADM and SYSCTRL authority and can drop a role or trusted context.

Row permission or column mask:

At least SECADM authority

User-defined type, global variable, sequence, stored procedure, trigger, or user-defined function:

- Ownership of the object ³⁴
- The DROPIN privilege on the schema
- SYSADM or SYSCTRL authority
- System DBADM
- Installation SYSOPR authority (when the current SQLID of the process is set to SYSINSTL)

³⁴ Not applicable for stored procedures defined in releases of Db2 for z/OS prior to Version 6.

The authorization ID that matches the schema name implicitly has the DROPIN privilege on the schema.

Privilege set: If the statement is embedded in an application program, the privilege set is the privileges that are held by the owner of the plan or package. If the statement is dynamically prepared, the privilege set is the union of the privilege sets that are held by each authorization ID of the process. If running in a trusted context with a role, the privilege set also includes those privileges that are held by the role that is associated with the primary authorization ID. However, the implicit schema match does not apply to the role when determining if DROPIN schema privilege is held.

Syntax for DROP

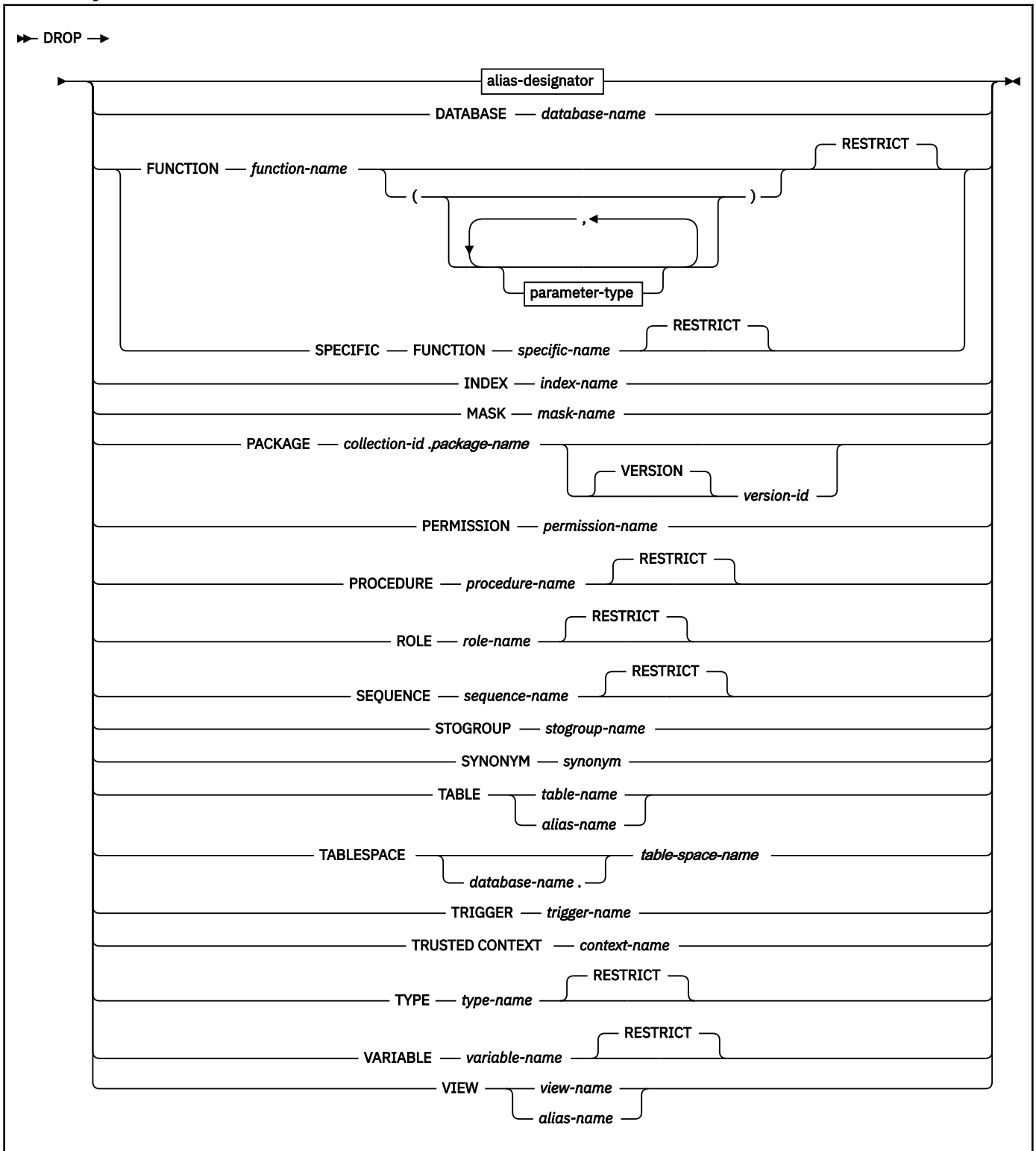

alias-designator:

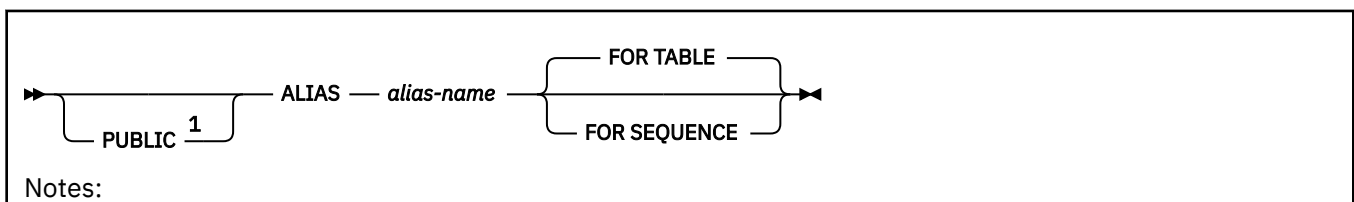

Notes:

¹ If PUBLIC is specified, FOR SEQUENCE must also be specified.

parameter type:

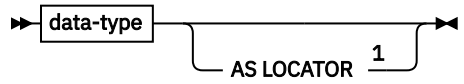

Notes:

¹ AS LOCATOR can be specified only for a LOB data type or a distinct type based on a LOB data type.

data type:

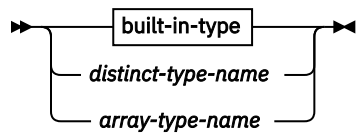

built-in-type:

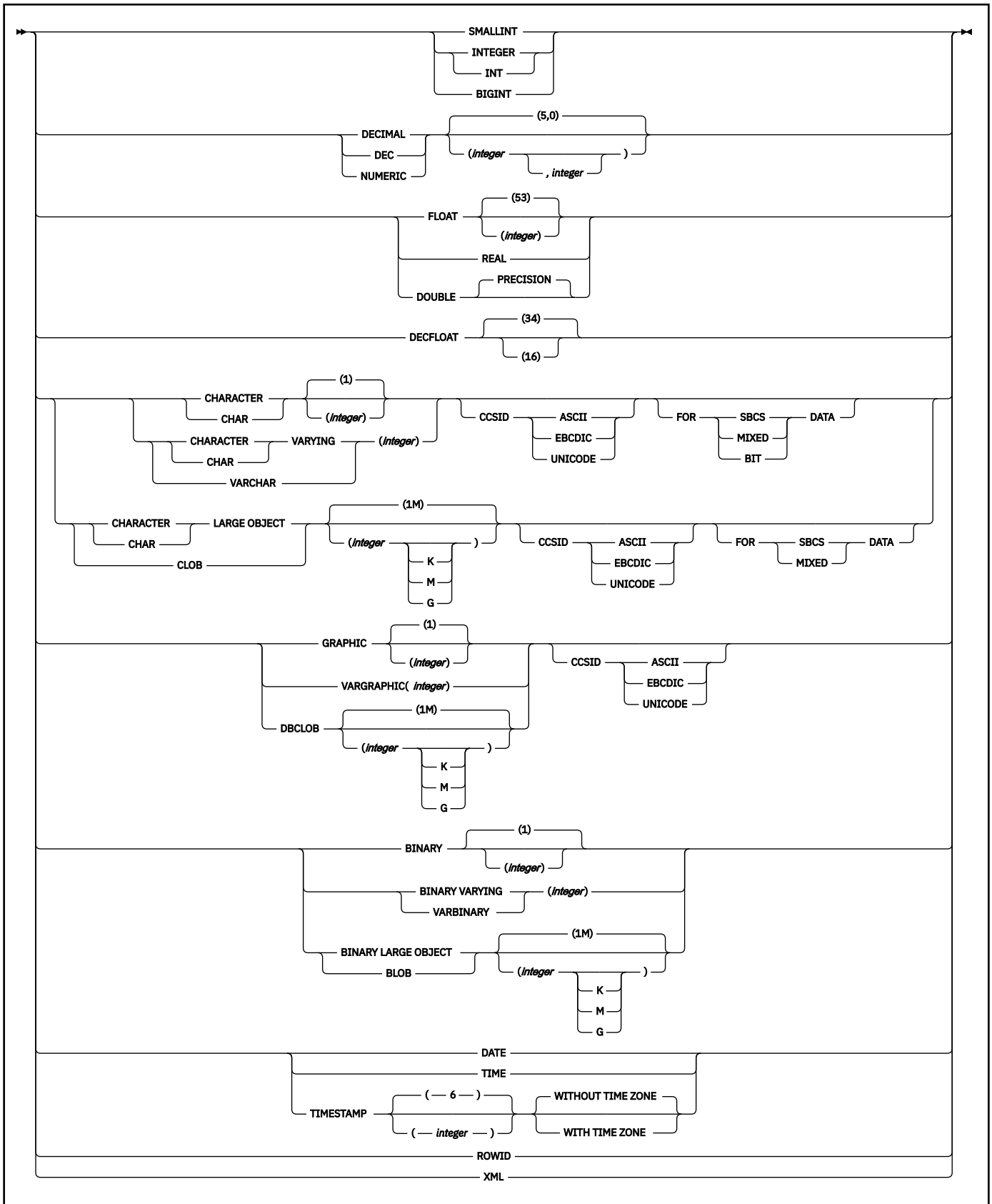

Description for DROP
alias-designator

PUBLIC

Specifies that the alias to be dropped is a public alias. The *alias-name* must identify an alias that exists in the SYSPUBLIC schema.

If the PUBLIC keyword is specified, *alias-name* must identify a public alias that exists at the current server.

ALIAS *alias-name*

Identifies the alias to be dropped. The *alias-name* must identify an alias that exists at the current server.

Dropping an alias for a table or view has no effect on any view, materialized query table, or synonym that was defined using the alias. If the alias is referenced in the definition of a row permission or a column mask, it cannot be dropped.

Dropping an alias for a sequence has no effect on any view or materialized query table that was defined using the alias. If the alias is referenced in the definition of an inline SQL function, it cannot be dropped. When an alias for a sequence is dropped, all packages that refer to the sequence alias are invalidated.

If the alias is referenced in the definition of a row permission or a column mask, the alias cannot be dropped.

FOR TABLE

Specifies that the alias to be dropped is for a table or view. Dropping an alias for a table has no effect on any view, materialized query table, or synonym that was defined using the alias.

FOR SEQUENCE

Specifies that the alias to be dropped is for a sequence. Dropping an alias for a sequence has no effect on any view, or materialized query table that was defined using the alias.

DATABASE *database-name*

Identifies the database to drop. The name must identify a database that exists at the current server. DSNDB04 or DSNDB06 must not be specified. The privilege set must include SYSADM authority.

Whenever a database is dropped, all of its table spaces, tables, index spaces, and indexes are also dropped. Any pending changes to the definitions of the table spaces and indexes in the database are also dropped.

You can drop a database that contains a history table only if the database also contains the associated system-period temporal table. You can drop a database that contains a system-period temporal table when the associated history table is in another database. In this case, the action cascades to drop the history table in the other database.

You can drop a database that contains an archive table only if the database also contains the associated archive-enabled table. You can drop a database that contains an archive-enabled table when the associated archive table is contained in another database. In this case, the action cascades to drop the archive table in the other database.

The database cannot be dropped if it is associated with an accelerator-only table.

FUNCTION or SPECIFIC FUNCTION

Identifies the function to drop. The function must exist at the current server, and it must have been defined with the CREATE FUNCTION statement. The particular function can be identified by its name, function signature, or specific name. The specified function definition is dropped from the schema.

Functions that are implicitly generated by the CREATE TYPE statement cannot be dropped using the DROP statement. They are implicitly dropped when the distinct type is dropped.

As indicated by the default keyword RESTRICT, the function is not dropped if any of the following dependencies exist:

- Another function is sourced on the function.
- A view uses the function.
- A trigger package uses the function.

- The definition of a materialized query table uses the function.
- The definition of a row permission or a column mask uses the function.

When a function is dropped, all privileges on the function are also dropped. Any packages that are dependent on the function dropped are made inoperative. All package copies are also marked as `VALID='NO'`. If the function is a compiled SQL scalar function, the package associated with the function is also dropped.

All versions of a compiled SQL scalar function are dropped. To drop a specific version of a compiled SQL scalar function, use an [“ALTER FUNCTION statement \(compiled SQL scalar function\)”](#) on page 1113 statement with the `DROP VERSION` clause.

FUNCTION *function-name*

Identifies the function by its name. The *function-name* must identify exactly one function. The function can have any number of parameters defined for it. If there is more than one function of the specified name in the specified or implicit schema, an error is returned.

FUNCTION *function-name (parameter-type,...)*

Identifies the function by its function signature, which uniquely identifies the function. The *function-name (parameter-type, ...)* must identify a function with the specified function signature. The specified parameters must match the data types in the corresponding position that were specified when the function was created. The number of data types, and the logical concatenation of the data types is used to identify the specific function instance which is to be dropped. Synonyms for data types are considered a match.

If the function was defined with a table parameter (the `LIKE TABLE name AS LOCATOR` clause was specified in the `CREATE FUNCTION` statement to indicate that one of the input parameters is a transition table), the function signature cannot be used to uniquely identify the function. Instead, use one of the other syntax variations to identify the function with its function name, if unique, or its specific name.

If *function-name ()* is specified, the function identified must have zero parameters.

function-name

Identifies the name of the function.

(parameter-type,...)

Identifies the parameters of the function.

If an unqualified distinct type name is specified, Db2 searches the SQL path to resolve the schema name for the distinct type.

For data types that have a length, precision, or scale attribute, use one of the following:

- Empty parentheses indicate that the database manager ignores the attribute when determining whether the data types match. For example, `DEC()` will be considered a match for a parameter of a function defined with a data type of `DEC(7,2)`. Similarly `DECFLOAT()` will be considered a match for `DECFLOAT(16)` or `DECFLOAT(34)`. However, `FLOAT` cannot be specified with empty parenthesis because its parameter value indicates a specific data type (`REAL` or `DOUBLE`).
- If a specific value for a length, precision, or scale attribute is specified, the value must exactly match the value that was specified (implicitly or explicitly) in the `CREATE FUNCTION` statement. If the data type is `FLOAT`, the precision does not have to exactly match the value that was specified because matching is based on the data type (`REAL` or `DOUBLE`).
- If length, precision, or scale is not explicitly specified, and empty parentheses are not specified, the default attributes of the data type are implied. The implicit length must exactly match the value that was specified (implicitly or explicitly) in the `CREATE FUNCTION` statement.

For data types with a subtype or encoding scheme attribute, specifying the `FOR subtype DATA` clause or the `CCSID` clause is optional. Omission of either clause indicates that Db2 ignores the attribute when determining whether the data types match. If you specify either clause,

it must match the value that was implicitly or explicitly specified in the CREATE FUNCTION statement.

AS LOCATOR

Specifies that the function is defined to receive a locator for this parameter. If AS LOCATOR is specified, the data type must be a LOB or a distinct type based on a LOB.

SPECIFIC FUNCTION *specific-name*

Identifies the function by its specific name. The *specific-name* must identify a specific function that exists at the current server.

INDEX *index-name*

Identifies the index to drop. The name must identify a user-defined index that exists at the current server but must not identify a populated index on an auxiliary table or an index that was implicitly created for a table that contains an XML column. (For details on dropping user-defined indexes on catalog tables, see [“SQL statements allowed on the catalog”](#) on page 2739.) A populated index on an auxiliary table can only be dropped by dropping the base table. The name must not identify an auxiliary table for an object that is involved in a clone relationship.

If the index that is dropped was created by specifying the ENDING AT clause to define partition boundaries, the table is converted to use table-controlled partitioning. The high limit key for the last partition is set to the highest possible value for ascending key columns or the lowest possible value for descending key columns.

Whenever an index is directly or indirectly dropped, its index space is also dropped. The name of a dropped index space cannot be reused until a commit operation is performed. Any pending changes to the definitions of the index is also dropped.

If the index is a unique index used to enforce a unique constraint (primary or unique key), the unique constraint must be dropped before the index can be dropped. In addition, if a unique constraint supports a referential constraint, the index cannot be dropped unless the referential constraint is dropped.

However, a unique index (for a unique key only) can be dropped without first dropping the unique key constraint if the unique key was created in a release of Db2 before Version 7 and if the unique key constraint has no associated referential constraints. For information about dropping constraints, see [“ALTER TABLE statement”](#) on page 1232.

If the index is used for the foreign key of a temporal referential constraint, the referential constraint must be dropped before the index can be dropped.

If the table space is explicitly created and a unique index is dropped and that index was defined on a ROWID column that is defined as GENERATED BY DEFAULT, the table can still be used, but rows cannot be inserted into that table.

If the table space is implicitly created, the index cannot be dropped if it is defined on a ROWID column that is defined as GENERATED BY DEFAULT.

If an empty index on an auxiliary table is dropped, the base table is marked incomplete. If the base table space is implicitly created, the index on an auxiliary table cannot be dropped.

Drop index will result in the deletion of rows in the SYSCOLDIST and SYSCOLDISTATS catalog tables if no other indexes on the table have the same column group in their key sequence prefix.

MASK *mask-name*

Identifies the column mask to drop. The name must identify a column mask that exists at the current server.

PACKAGE *collection-id.package-name*

Identifies the package version to drop. The name plus the implicitly or explicitly specified *version-id* must identify a package version that exists at the current server. Omission of the *version-id* is an implicit specification of the null version.

The name must not identify a trigger package or a package that is associated with an SQL routine. A trigger package can only be dropped by dropping the associated trigger or subject table. A package

that is associated with a native SQL procedure can only be dropped with an ALTER PROCEDURE statement with a DROP VERSION clause that specifies the particular version that is to be dropped, or with a DROP PROCEDURE statement if it is the only version that is defined for the procedure.

Specify this clause to drop a package that is created as the result of a BIND COPY command used to deploy a version of a native SQL procedure.

If a package has current, previous, and original copies, the DROP statement will drop all copies.

VERSION *version-id*

version-id is the version identifier that was assigned to the package's DBRM when the DBRM was created. If *version-id* is not specified, a null version is used as the version identifier.

Delimit the version identifier when it:

- Is generated by the VERSION(AUTO) precompiler option
- Begins with a digit
- Contains lowercase or mixed-case letters

For more on version identifiers, see the information on preparing an application program for execution in [Creating a package version \(Db2 Application programming and SQL\)](#).

PERMISSION *permission-name*

Identifies the row permission to drop. The name must identify a row permission that exists at the current server. The name must not identify the default row permission that was created implicitly by Db2.

PROCEDURE *procedure-name*

Identifies the stored procedure to drop. The name must identify a stored procedure that was defined with the CREATE PROCEDURE statement at the current server. The specified procedure definition is dropped from the schema. All privileges on the procedure are also dropped, and any packages that are dependent on the procedure are marked invalid. If the procedure is an SQL procedure, the package that is associated with the procedure is also dropped.

As indicated by the default keyword RESTRICT, the procedure is not dropped if any of the following dependencies exist:

- A trigger definition contains a CALL statement that identifies the procedure.
- An SQL routine definition contains a CALL statement that identifies the procedure.

All versions of a native SQL procedure are dropped. To drop a specific version of a native SQL procedure, use an [“ALTER PROCEDURE statement \(SQL - native procedure\)”](#) on page 1194 statement with the DROP VERSION clause.

Use a DROP PACKAGE statement to drop a package for a version of a native SQL procedure that is created using the BIND COPY command.

ROLE *role-name*

Identifies the role to drop. *role-name* must identify a role that exists at the current server.

When a role is dropped, all privileges and authorities that have been previously granted to that role are revoked. If the role that is dropped is the owner of statements in the dynamic statement cache, the cached statements are invalidated.

The role is not dropped if any REVOKE restrictions are encountered. REVOKE restrictions include the following:

- Restrictions that are encountered when dependent privileges are included when the privileges of a role are revoked.
- The role is the grantor of any privilege or authority that used ACCESSCTRL or SECADM authority to perform the grant.

If RESTRICT is specified, the role is not dropped if any of the following dependencies exist:

- The role is associated with any trusted context or any user in a trusted context.

- The role is associated with a currently running thread.
- The role is the owner of any of the following objects:

Object	Object
Alias	Row permission
Array type	Sequence
Column mask	Storage group
Database	Stored procedure
Distinct type	Table
Global variable	Table space
Index	Trigger
JAR file	Trusted context
Materialized query table	User-defined function
Package	View
Role	

SEQUENCE *sequence-name*

Identifies the sequence to drop. The name must identify an existing sequence at the current server.

sequence-name must not be the name of an internal sequence object that is used by Db2 (including an implicitly generated sequence for a DB2_GENERATED_DOCID_FOR_XML column). Sequences that are generated by the system for identity columns or implicitly created databases cannot be dropped by using the DROP SEQUENCE statement. A sequence object for an identity column is implicitly dropped when the table that contains the identity column is dropped.

The default keyword RESTRICT indicates that the sequence is not dropped if any of the following dependencies exist:

- A trigger that uses the sequence in a NEXT VALUE or PREVIOUS VALUE expression exists.
- An inline SQL function that uses the sequences in a NEXT VALUE or PREVIOUS VALUE expression exists.

Whenever a sequence is dropped, all privileges on the sequence are also dropped, and the packages that refer to the sequence are invalidated. Dropping a sequence, even if the drop process is rolled back, results in the loss of the still-unassigned cache values for the sequence.

STOGROUP *stogroup-name*

Identifies the storage group to drop. The name must identify a storage group that exists at the current server but not a storage group that is used by any table space or index space.

For information on the effect of dropping the default storage group of a database, see [Dropping a default storage group](#).

SYNONYM *synonym*

Identifies the synonym to drop. In a static DROP SYNONYM statement, the name must identify a synonym that is owned by the owner of the plan or package. In a dynamic DROP SYNONYM statement, the name must identify a synonym that is owned by the SQL authorization ID. Thus, using interactive SQL, a user with SYSADM authority can drop any synonym by first setting CURRENT SQLID to the owner of the synonym.

Dropping a synonym invalidates dependent packages and the dynamic statement cache. Dropping a synonym has no effect on any view, materialized query table, or alias that was defined using the synonym.

If the synonym is referenced in the definition of a row permission or a column mask, it cannot be dropped.

TABLE *table-name or alias-name*

Identifies the table to drop. The name must identify a table that exists at the current server. It must not identify any of the following types of tables:

- A catalog table
- A directory table
- [FL 506](#) A table in a partitioned (non-UTS) table space
- A table that is implicitly created for an XML column
- A populated auxiliary table

A table in a partitioned (non-UTS) table space can be dropped only by dropping the table space. A populated auxiliary table or a table that is implicitly created for an XML column can be dropped only by dropping the associated base table.

If *alias-name* is specified, the actual table is dropped as if *table-name* were specified. However, the alias is not dropped. It can be dropped by using the DROP ALIAS statement.

When a table is directly or indirectly dropped, the following items are also dropped:

- All privileges on the table
- All referential constraints in which the table is a parent or dependent
- All synonyms, views, and indexes that are defined on the table
- All row permissions (including the default row permission)
- All column masks that are created for the table

[FL 506](#) If the table space for the table is a universal table space, a LOB table space, or implicitly created, it is also dropped. However, if the containing database was implicitly created, it is not dropped. Any pending changes to the definitions of the dropped table space and indexes are also dropped.

For more information, see [Dropping an implicitly created database](#).

When a table is directly or indirectly dropped, all materialized query tables that are defined on the table are also dropped. When a materialized query table is directly or indirectly dropped, the following items are also dropped:

- All privileges on the materialized query table
- All synonyms, views, and indexes that are defined on the materialized query table

Any alias that is defined on the materialized query table is not dropped. Any packages that are dependent on the dropped materialized query table are marked invalid.

You cannot use DROP TABLE to drop a clone table. You must use the ALTER TABLE statement with the DROP CLONE clause to drop a clone table. If a base table that is involved in a clone relationship is dropped, the associated clone table is also dropped. You cannot drop an auxiliary table for an object that is involved in a clone relationship.

The table cannot be dropped if it is defined as a history table for a system-period temporal table.

The table cannot be dropped if it is referenced in the definition of a row permission or a column mask.

To drop a system-period temporal table, the privilege set must also contain the authorization that is required to drop the history table. The history table is dropped when a system-period temporal table is dropped.

If a table with LOB columns is dropped, the auxiliary tables that are associated with the table and the indexes on the auxiliary tables are also dropped. [FL 506](#) Db2 also drops the LOB table spaces that contain the auxiliary tables, regardless of whether the LOB table spaces were implicitly or explicitly created.

If a table with XML columns is dropped, all implicitly created objects for all XML columns are also dropped.

If an empty auxiliary table is dropped, the definition of the base table is marked incomplete. If the base table space is implicitly created, the auxiliary table cannot be dropped.

If the table has a security label column, the primary authorization ID of the DROP statement must have a valid security label, and the RACF SECLABEL class must be active.

If a table that uses hash organization is dropped, all catalog entries for the hash organization are cleaned up.

If an archive-enabled table is dropped, the archive table and any indexes that are defined on the archive table are also dropped. To drop an archive-enabled table, the privilege set must also contain the authorization that is required to drop the archive table. An archive table cannot be explicitly dropped by using the DROP statement.

TABLESPACE *database-name.table-space-name*

Identifies the table space to drop. The name must identify a table space that exists at the current server. The database name must not be DSNDB01 or DSNDB06. Omission of the database name is an implicit specification of DSNDB04. *table-space-name* must not identify a table space that is implicitly created for an XML column.

Whenever a table space is directly or indirectly dropped, all the tables in the table space are also dropped. The name of a dropped table space cannot be reused until a commit operation is performed. Any pending changes to the definitions of the table space and its indexes are also dropped.

A LOB table space can be dropped only if it does not contain an auxiliary table. If the LOB table space is implicitly created, it cannot be dropped.

Whenever a base table space that contains tables with LOB columns is dropped, all the auxiliary tables and indexes on those auxiliary tables that are associated with the base table space are also dropped.

Whenever a base table space that contains tables with XML columns is dropped, all implicitly created objects for all XML columns are also dropped.

The table space cannot be dropped if it contains a history table, an archive table, or is associated with an accelerator-only table.

TRIGGER *trigger-name*

Identifies the trigger to drop. The name must identify a trigger that exists at the current server.

Whenever a trigger is directly or indirectly dropped, all privileges on the trigger are also dropped and the associated trigger package is freed. The name of that trigger package is the same as the trigger name and the collection ID is the schema name.

When an INSTEAD OF trigger is dropped, the associated privilege is revoked from anyone that possesses the privilege as a result of an implicit grant that occurred when the trigger is created.

Dropping triggers causes certain packages to be marked invalid. For example, if *trigger-name* specifies an INSTEAD OF trigger on a view V, another trigger might depend on *trigger-name* through an update to the view V, and that trigger package is invalidated.

If a trigger has current, previous, and original copies, the DROP statement will drop all copies.

For an advanced trigger, all versions of the trigger are dropped. Use an ALTER TRIGGER statement with the DROP VERSION clause to drop a specific version of a trigger.

TRUSTED CONTEXT *context-name*

Identifies the trusted context to drop. The *context-name* must identify a trusted context that exists at the current server. When a trusted context is dropped, all associations to attributes (IP addresses, job names) and associations to users of the trusted context are dropped. If the trusted context is dropped while trusted connections for the context are active, the connections remain active until they terminate or the next attempt at reuse is made.

TYPE *type-name*

Identifies the user-defined type to drop. The name must identify a user-defined type that exists at the current server. The default keyword RESTRICT indicates that the user-defined type is not dropped if any of the following dependencies exist:

- The definition of a column of a table uses the user-defined type.

- The definition of an input or result parameter of a user-defined function uses the user-defined type.
- The definition of a parameter of a stored procedure uses the user-defined type.
- The definition of an extended index uses a cast function that is implicitly generated for the user-defined type.
- The definition of an SQL variable in a procedure or function uses the user-defined type.
- The definition of a row permission or a column mask uses the user-defined type.
- A sequence exists for which the data type of the sequence is the user-defined type.
- One of the following dependencies exists on one of the cast functions that are generated for the user-defined type:
 - Another function is sourced from one of the cast functions
 - A view uses one of the cast functions
 - A trigger package uses one of the cast functions
 - The definition of a materialized query table uses one of the cast functions

Whenever a user-defined type is dropped, all privileges on the distinct type are also dropped. In addition, the cast functions that were generated when the user-defined type was created and the privileges on those cast functions are also dropped.

VARIABLE *variable-name*

Identifies the global variable to drop. The name must identify a global variable that exists at the current server. The name must not identify a built-in global variable. The default keyword **RESTRICT** indicates that the global variable is not dropped if any of the following dependencies exist:

- The definition of a function, trigger, or view is dependent on the global variable

Packages that are dependent on the global variable are marked invalid when the global variable is dropped. If a statement that is in the dynamic statement cache depends on the global variable and the global variable is dropped, the statement in the dynamic statement cache will be invalidated if it is not in use.

VIEW *view-name* or *alias-name*

Identifies the view to drop. The name must identify a view that exists at the current server.

Whenever a view is directly or indirectly dropped, all privileges on the view and all synonyms and views that are defined on the view are also dropped. Whenever a view is directly or indirectly dropped, all materialized query tables defined on the view are also dropped.

If *alias-name* is specified, the actual view will be dropped as if *view-name* were specified. However, the alias is not dropped and can be dropped using the **DROP ALIAS** statement.

If the view is referenced in the definition of a row permission or a column mask, it cannot be dropped.

Notes for DROP

Restrictions on DROP:

DROP is subject to these restrictions:

- **DROP DATABASE** cannot be performed while a Db2 utility has control of any part of the database.
- **DROP INDEX** cannot be performed while a Db2 utility has control of the index or its associated table space.
- **DROP INDEX** cannot be performed if the index is a unique index that is defined on a ROWID column that is defined as **GENERATED BY DEFAULT** and there are pending changes to the definition of the table space or to any objects within the table space that are explicitly created.
- **DROP INDEX** cannot be performed if the index is an empty index on an auxiliary table that resides in an explicitly created LOB table space and there are pending changes to the definition of the base table space or to any objects within the base table space.

- DROP INDEX cannot be performed if the index is the hash overflow index for a table that uses hash organization.
- DROP TABLE cannot be performed while a Db2 utility has control of the table space that contains the table.
- DROP TABLE cannot be performed if the table is an empty auxiliary table and there are any pending changes to the definition of the base table space or to any objects within the base table space.
- DROP TABLESPACE cannot be performed while a Db2 utility has control of the table space.

In a data sharing environment, the following restrictions also apply:

- If any member has an active resource limit specification table (RLST) you cannot drop the database or table space that contains the table, the table itself, or any index on the table.
- If the member executing the drop cannot access the Db2-managed data sets, only the catalog and directory entries for those data sets are removed.

Objects that have certain dependencies cannot be dropped. For information on these restrictions, see [Table 231 on page 1903](#).

Recreating objects:

After an index or table space is dropped, a commit must be performed before the object can be re-created with the same name. If a table that was created without an IN clause (thereby causing a table space to be implicitly created) is dropped, a table cannot be re-created with the same name until a commit is performed.

Dropping a parent table:

DROP is not DELETE and therefore does not involve delete rules.

Dropping a default storage group:

If you drop the default storage group of a database, the database no longer has a legitimate default. You must then specify USING in any statement that creates a table space or index in the database. You must do this until you either:

- Create another storage group with the same name using the CREATE STOGROUP statement, or
- Designate another default storage group for the database using the ALTER DATABASE statement.

Dropping an accelerator-only table:

- When an accelerator-only table is dropped and the accelerator is not active, use the SYSACCEL_DROP_TABLE procedure to drop the table in the accelerator.
- A DROP TABLE statement that identifies an accelerator-only table should be issued in a separate unit of work from other SQL statements.

Dropping an implicitly created database:

When a table that resides in an implicitly created table space is dropped, the implicitly created table space and related objects are dropped. However, the implicitly created database is not dropped. This can result in a large number of empty databases in a system. These databases might be eventually reused for newly created implicit table spaces. These implicitly created databases can be dropped using DROP DATABASE.

Dropping a table space or index:

To drop a table space or index, the size of the buffer pool associated with the table space or index must not be zero.

Dropping a LOB table space:

FL 506 When an auxiliary table that resides in a LOB table space is dropped, the LOB table space is automatically dropped. An explicitly created LOB table space can be dropped if it does not contain an auxiliary table.

Dropping a database when data sets for Db2 objects have already been deleted:

When some of the data sets for Db2 objects that associated with the database have already been deleted, DROP DATABASE will perform in the following manner:

For Db2-managed objects:

The DROP DATABASE statement will delete the underlying data sets if they exist. If the data sets do not exist, DROP DATABASE will delete only the catalog entries for those data sets.

For user-managed objects:

The DROP DATABASE statement will delete only the catalog entries for the data sets. The underlying data sets will need to be manually deleted after the DROP DATABASE statement is complete.

Dropping a table space in a work file database:

If one member of a data sharing group drops a table space in a work file database, or an entire work file database, that belongs to another member, Db2-managed data sets that the executing member cannot access are not dropped. However, the catalog and directory entries for those data sets are removed.

Dropping resource limit facility (governor) indexes, tables, and table spaces:

While the RLST is active, you cannot issue a DROP DATABASE, DROP INDEX, DROP TABLE, or DROP TABLESPACE statement for an object associated with an RLST that is active on any member of a data sharing group. See [Resource limit facility implications for data sharing \(Db2 Data Sharing Planning and Administration\)](#) for details.

Dropping a temporary table:

To drop a created temporary table or a declared temporary table, use the DROP TABLE statement.

Dropping a materialized query table:

To drop a materialized query table, use the DROP TABLE statement.

Dropping an alias:

Dropping a table or view does not drop its aliases. However, if you use the DROP TABLE statement and specify an alias for a table or view, the table or view will be dropped. To drop an alias, use the DROP ALIAS statement.

Dropping a table from an implicitly created table space:

If you drop a table from an implicitly created table space, the following related objects are also dropped:

- The enforcing primary and unique key indexes
- Any LOB table spaces, auxiliary tables, and auxiliary indexes
- The ROWID index (if the ROWID column is defined as GENERATED BY DEFAULT)

FL 506 If any LOB columns are defined on the table, the LOB table space is dropped.

Dropping an index on a base table and auxiliary table:

You can explicitly drop an empty index on an auxiliary table with the DROP INDEX statement, unless the base table space is implicitly created. An empty or populated index on an auxiliary table is implicitly dropped when:

- The auxiliary table is empty and it is explicitly dropped (empty indexes only).
- The associated base table for the auxiliary table is dropped.
- The base table space that contains the associated base table is dropped.

You can explicitly drop an empty auxiliary table with the DROP TABLE statement, unless the base table space is implicitly created. An empty or populated auxiliary table is implicitly dropped when:

- The associated base table for the auxiliary table is dropped.
- The base table space that contains the associated base table is dropped.

The following table shows which DROP statements implicitly or explicitly cause an auxiliary table and the index on that table to be dropped, as indicated by the 'D' in the column.

Table 230. Effect of various DROP statements on auxiliary tables and indexes that are in explicitly created table spaces

Statement	Auxiliary table		Index on auxiliary table	
	Populated	Empty	Populated	Empty
DROP TABLESPACE (base table space)	D	D	D	D
DROP TABLE (base table)	D	D	D	D
DROP TABLE (auxiliary table)		D		D
DROP INDEX (index on auxiliary table)				D

Note: D indicates that the table or index is dropped.

Dropping a migrated index or table space:

Here, "migration" means migrated by the Hierarchical Storage Manager (DFSMSHsm). Db2 does not wait for any recall of the migrated data sets. Hence, recall is not a factor in the time it takes to execute the statement.

Dropping a trusted context:

The drop of a trusted context takes effect after the DROP TRUSTED CONTEXT statement is committed. If the DROP TRUSTED CONTEXT statement results in an error or is rolled back, the trusted context is not dropped.

Avoiding DROP failure due to excessive locking

Dropping a table space, database, or index with the COPY YES attribute deletes all corresponding records in the SYSCOPY and SYSLGRNX catalog statistics tables. The DROP fails if the lock structure size cannot accommodate the number of locks obtained during DROP processing. DROP failure is more likely if the SYSCOPY, SYSLGRNX, or other catalog statistics tables contain many entries, especially if the object you are dropping was created long ago or contains many partitions. DROP failure is also more likely if objects are copied frequently while the MODIFY RECOVERY and MODIFY STATISTICS utilities are run relatively infrequently.

To avoid DROP failure, run the MODIFY RECOVERY and MODIFY STATISTICS utilities on objects before dropping them. If you drop a clone table, you need to specify the CLONE keyword to delete recovery and statistics information for the clone objects from the catalog and directory. You can Specify AGE(*) or DATE(*) to remove all recovery and statistics information regardless of past update, copy, or cleanup frequency. Be aware that running the MODIFY utility with AGE(*) or DATE(*) will leave objects unrecoverable after they are dropped unless you make a copy or other form of back-up first.

Also, ensure that your applications commit drops frequently, especially for databases containing multiple table spaces, and table spaces containing multiple tables. You can also increase the size of your lock structures to accommodate the surge in lock requests during this type of activity.

Invalidation of packages:

This statement might invalidate all packages that depend on target objects, and sometimes other related objects through cascading effects, depending on the clauses and keywords specified and other factors. For more information, see [Changes that invalidate packages \(Db2 Application programming and SQL\)](#).

Dependencies when dropping objects:

If other objects depend on the object specified in a DROP statement, the dependent objects might also be dropped, invalidated, or become inoperative, or the DROP statement might fail. These effects also cascade to any objects that depend on the dropped dependent objects. To determine the full indirect effects of a DROP statement, check what happens for any dependent objects, check whether each dependent object has its own dependent objects, and the check the rules for those object types.

The following table indicates the result of DROP statements based on the type of object specified by the DROP statement and the type of dependent object. The letters have the following meanings:

D (cascaded drop)

If any dependent objects of the indicated types exist, they are also dropped. The effect cascades to any objects that depend on the dropped dependent objects.

R (restrict)

If any dependent objects of the indicated types exist, the DROP statement fails. Also, if any dependent object cannot be dropped because of a restrict dependency for its own dependent objects, the DROP statement fails.

V (invalidate)

If dependent packages exist, they become invalidated.

For example, assume that view B is defined on table A and view C is defined on view B. In the following table, the 'D' in the View column of the DROP TABLE row indicates that view B is dropped when table A is dropped. Next, because view C is dependent on view B, check the View column for DROP VIEW. The 'D' in the column indicates that view C will also be dropped.

Table 231. Effect of dropping objects that have dependencies

DROP statement	Dependent object type															
	Alias	Column	Function	Global variable	Index	Procedure	Row	Sequence	Storage	Synonym	Table	Tablespace	Trigger	Type	View	
DROP ALIAS	R	V				V	R						V			
DROP FUNCTION			R "4" on page 1905			R "12" on page 1905							R		R	
DROP INDEX "1" on page 1905			V			V							V			
DROP PROCEDURE			R "12" on page 1905			R "12" on page 1905							R			
DROP ROLE	R	R	R	R	R	R	R	R	R	R	R	R	R	R	R	

Table 231. Effect of dropping objects that have dependencies (continued)

DROP statement	Dependent object type														
	Aliases	Column masks	Function names	Global variables	Indexes	Procedures	Permissions	Sequences	Stogroups	Synonyms	Tables	Tablespaces	Triggers	Type	View
DROP SEQUENCE			R“8” on page 1905			R“12” on page 1905								R	
DROP STOGROUP					R“5” on page 1905									R“5” on page 1905	
DROP SYNONYM	R														
DROP TABLE “6” on page 1905	R“16” on page 1905	D“14” on page 1905		D	V	R“16” on page 1905				D	D“15” on page 1905		D“7” on page 1905		D
DROP TABLESPACE		V		D	V						D		V		
DROP TRIGGER		V				V							V		
DROP TYPE	R	R“2” on page 1905		R“9” on page 1905	R“3” on page 1905	R	R				R		V“11” on page 1905		
DROP VARIABLE			R			V							R		R
DROP VIEW	R	D“14” on page 1905				V	R			D	D“15” on page 1905		D“10” on page 1905		D

Table notes:

1. The index space associated with the index is dropped.
2. If a function is dependent on the user-defined type being dropped, the user-defined type cannot be dropped unless the function is one of the cast functions that was created for the user-defined type.
3. If the definition of a parameter of a stored procedure uses the user-defined type, the user-defined type cannot be dropped.
4. If other user-defined functions are sourced on the user-defined function being dropped, the function cannot be dropped.
5. A storage group cannot be dropped if it is used by any table space or index space.
6. FL 506 If the table resides in an explicitly created universal table space or any implicitly created table space, the table space is also dropped.
7. When a subject table is dropped, any associated triggers and related trigger packages are also dropped.
8. This restriction is only for SQL functions.
9. The index in this case must be an expression-based index.
10. When a subject view is dropped, any associated triggers and related trigger packages are also dropped.
11. Any packages that have a dependency on an INSTEAD OF trigger will be marked invalid.
12. A routine or sequence that is referenced by a native SQL procedure cannot be dropped.
13. An alias or synonym cannot be dropped if there is a dependent inline SQL table function.
14. When a table or view is dropped, any dependent inline SQL table functions are also dropped.
15. When a table or view is dropped, any dependent materialized query tables are also dropped.
16. When a table is dropped, any row permission or column masks defined directly on the table are also dropped. If any row permissions or column masks reference the table in the body, the table cannot be dropped.

Alternative syntax and synonyms:

To provide compatibility with previous releases of Db2 or other products in the Db2 family, Db2 supports the following keywords:

- DATA TYPE or DISTINCT TYPE as a synonym for TYPE
- PROGRAM as a synonym for PACKAGE
- DROP ALIAS SYSPUBLIC.*name* can be specified as an alternative to DROP PUBLIC ALIAS SYSPUBLIC.*name*

Examples for DROP**Example 1**

Drop table DSN8C10.DEPT.

```
DROP TABLE DSN8C10.DEPT;
```

Example 2

Drop table space DSN8S12D in database DSN8D12A.

```
DROP TABLESPACE DSN8D12A.DSN8S12D;
```

Example 3

Drop the view DSN8C10.VPROJRE1:

```
DROP VIEW DSN8C10.VPROJRE1;
```

Example 4

Drop the package DSN8CC0 with the version identifier VERSZZZ. The package is in the collection DSN8CC61. Use the version identifier to distinguish the package to be dropped from another package with the same name in the same collection.

```
DROP PACKAGE DSN8CC61.DSN8CC0 VERSION VERSZZZ;
```

Example 5

Drop the package DSN8CC0 with the version identifier "1994-07-14-09.56.30.196952". When a version identifier is generated by the VERSION(AUTO) precompiler option, delimit the version identifier.

```
DROP PACKAGE DSN8CC61.DSN8CC0 VERSION "1994-07-14-09.56.30.196952";
```

Example 6

Drop the distinct type DOCUMENT, if it is not currently in use:

```
DROP TYPE DOCUMENT;
```

Example 7

Assume that you are SMITH and that ATOMIC_WEIGHT is the only function with that name in schema CHEM. Drop ATOMIC_WEIGHT.

```
DROP FUNCTION CHEM.ATOMIC_WEIGHT;
```

Example 8

Assume that you are SMITH and that you created the function CENTER in schema SMITH. Drop CENTER, using the function signature to identify the function instance to be dropped.

```
DROP FUNCTION CENTER(INTEGER, FLOAT);
```

Example 9

Assume that you are SMITH and that you created another function named CENTER, which you gave the specific name FOCUS97, in schema JOHNSON. Drop CENTER, using the specific name to identify the function instance to be dropped.

```
DROP SPECIFIC FUNCTION JOHNSON.FOCUS97;
```

Example 10

Assume that you are SMITH and that stored procedure OSMOSIS is in schema BIOLOGY. Drop OSMOSIS.

```
DROP PROCEDURE BIOLOGY.OSMOSIS;
```

Example 11

Assume that you are SMITH and that trigger BONUS is in your schema. Drop BONUS.

```
DROP TRIGGER BONUS;
```

Example 12

Drop the role CTXROLE:

```
DROP ROLE CTXROLE;
```

Example 13

Drop the trusted context CTX1:

```
DROP TRUSTED CONTEXT CTX1;
```

Example 14

Drop public alias PUBALIAS1:

```
DROP PUBLIC ALIAS PUBALIAS1 FOR SEQUENCE;
```

END DECLARE SECTION statement

The END DECLARE SECTION statement marks the end of an SQL declare section.

Invocation for END DECLARE SECTION

This statement can only be embedded in an application program. It is not an executable statement. It must not be specified in Java or REXX.

Authorization for END DECLARE SECTION

None required.

Syntax for END DECLARE SECTION

```
►► END DECLARE SECTION ◄◄
```

Description for END DECLARE SECTION

The END DECLARE SECTION statement can be coded in the application program wherever declarations can appear in accordance with the rules of the host language. It is used to indicate the end of an SQL declare section. An SQL declare section starts with a BEGIN DECLARE SECTION statement described in “BEGIN DECLARE SECTION statement” on page 1383.

The following rules are enforced by the precompiler only if the host language is C or the STDSQL(YES) precompiler option is specified:

- A variable referred to in an SQL statement must be declared within an SQL declare section of the source program.
- BEGIN DECLARE SECTION and END DECLARE SECTION statements must be paired and must not be nested.
- SQL declare sections can contain only host variable declarations, SQL INCLUDE statements that include host variable declarations, or DECLARE VARIABLE statements.

Notes for END DECLARE SECTION

SQL declare sections are only required if the STDSQL(YES) option is specified or the host language is C. However, SQL declare sections can be specified for any host language so that the source program can conform to IBM SQL. If SQL declare sections are used, but not required, variables declared outside an SQL declare section should not have the same name as variables declared within an SQL declare section.

Example for END DECLARE SECTION

```
EXEC SQL BEGIN DECLARE SECTION;  
  -- host variable declarations  
EXEC SQL END DECLARE SECTION;
```

EXCHANGE statement

The EXCHANGE statement switches the content of a base table and its associated clone table.

Invocation for EXCHANGE

This statement can be embedded in an application program or issued interactively. It is an executable statement that can be dynamically prepared only if DYNAMICRULES RUN behavior is in effect. For more information, see [“Authorization IDs and dynamic SQL”](#) on page 94.

Authorization for EXCHANGE

The privilege set that is defined below must include at least one of the following privileges:

- The INSERT and DELETE privileges on both the base table and the clone table
- Ownership of the both the base table and the clone table
- DBADM authority for the database
- SYSADM authority
- DATAACCESS authority

Privilege set: If the statement is embedded in an application program, the privilege set is the privileges that are held by the owner of the plan or package. If the statement is dynamically prepared, the privilege set is the union of the privilege sets that are held by each authorization ID of the process.

Syntax for EXCHANGE

```
►► EXCHANGE DATA BETWEEN TABLE — table-name1 — AND — table-name2 ◄◄
```

Description for EXCHANGE

table-name1 and *table-name2*

Identifies the base table and the associated clone table for which the exchange of data will take place. Either *table-name1* or *table-name2* can identify the base table. The other table name must identify a clone table that is associated with the specified base table. The name of the base table and the name of the clone table remain unchanged after a data exchange.

Notes for EXCHANGE

Committing after EXCHANGE

A commit is required before accessing a table after the EXCHANGE statement and between consecutive data exchanges using the EXCHANGE statement.

Table partitions

Data exchanges cannot be done for a subset of table partitions.

Package rebinds might be needed

You might need to rebind packages that reference the base or clone tables before the applications can pick up the exchanged data. For more information, see [Changes that might require package rebinds \(Db2 Application programming and SQL\)](#).

Example for EXCHANGE

Exchange the data of the EMPLOYEE table and its clone table, EMPCLONE.

```
EXCHANGE DATA BETWEEN TABLE EMPCLONE AND EMPLOYEE;
```

Related concepts

Db2 tables ([Introduction to Db2 for z/OS](#))

Related tasks

[Exchanging data between a base table and clone table \(Db2 Administration Guide\)](#)

[Creating a clone table \(Db2 Administration Guide\)](#)

EXECUTE statement

The EXECUTE statement executes a prepared SQL statement.

Invocation for EXECUTE

This statement can only be embedded in an application program. It is an executable statement that cannot be dynamically prepared. It must not be specified in Java.

Authorization for EXECUTE

See “[PREPARE statement](#)” on page 2042 for the authorization required to create a prepared statement.

Syntax for EXECUTE

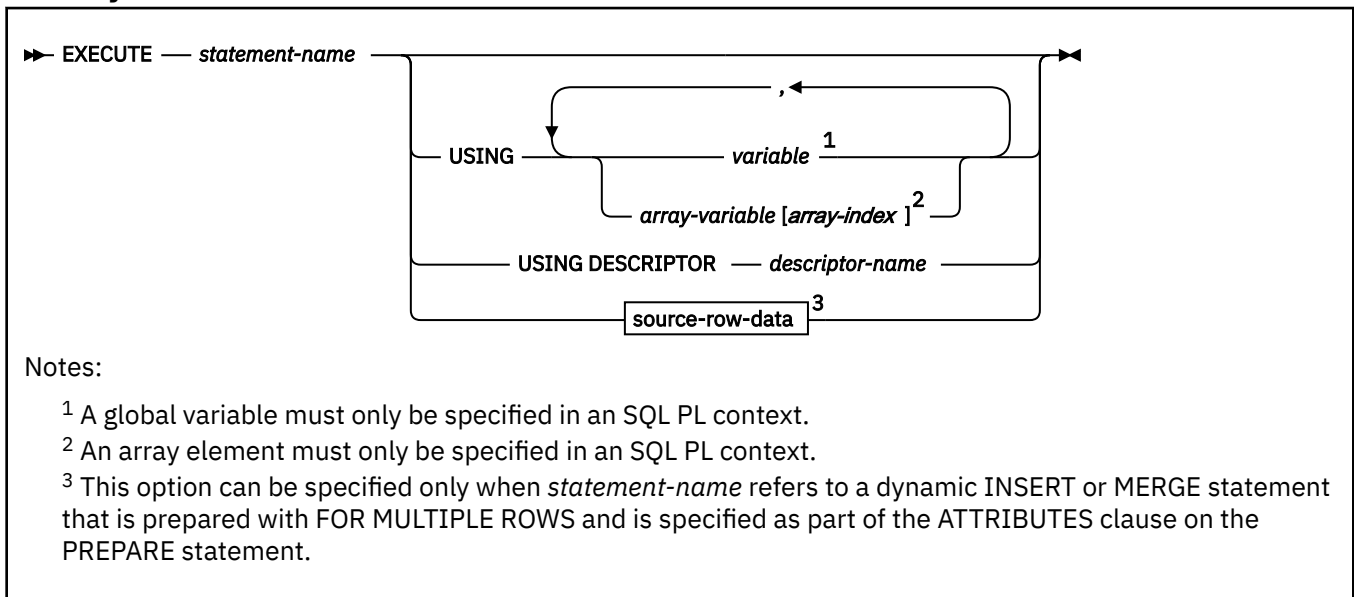

source-row-data:

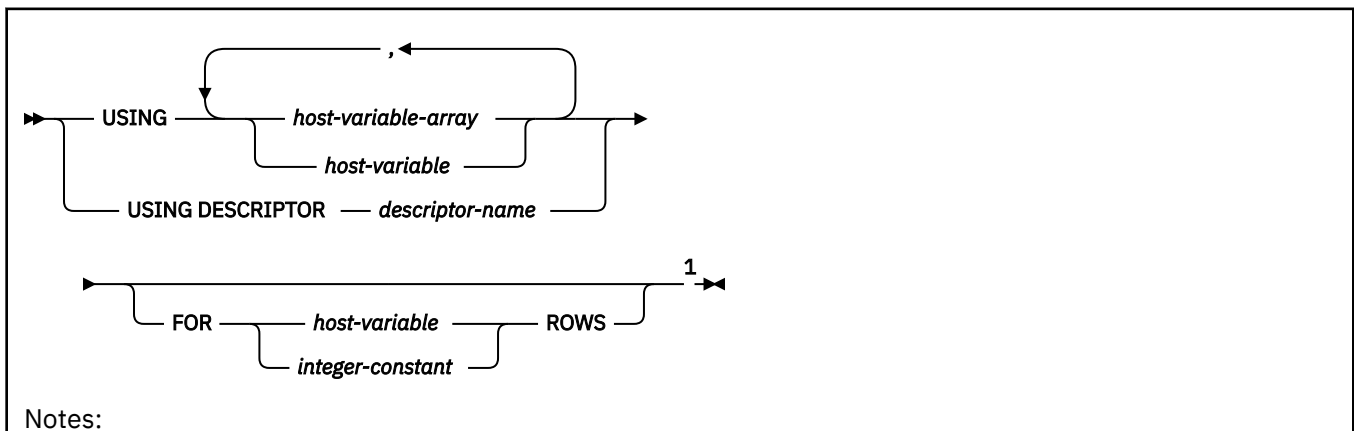

¹ The FOR n ROWS clause is required on the EXECUTE statement if it is not specified as part of the MERGE statement and a host-variable array is specified. The FOR n ROWS clause is also required if MERGE is used with multiple rows of source data. For an INSERT statement, the FOR n ROWS clause can only be specified for a dynamic statement that contains only a single multiple-row INSERT statement.

Description for EXECUTE

statement-name

Identifies the prepared statement to be executed. *statement-name* must identify a statement that was previously prepared within the unit of work and the prepared statement must not be a *select-statement*.

USING

Introduces a list of variables or an array element specification, whose values are substituted for the parameter markers (question marks) in the prepared statement. (For an explanation of parameter markers, see [“PREPARE statement”](#) on page 2042.) If the prepared statement includes parameter markers, you must include USING in the EXECUTE statement. USING is ignored if there are no parameter markers.

The *n*th value corresponds to the *n*th parameter marker in the prepared statement. Where appropriate, locator variables and file reference variables can be provided as the source of values for parameter markers.

For more on the substitution of values for parameter markers, see [Parameter marker replacement](#).

variable,...

Identifies a variable or a host structure that is declared in the application program in accordance with the rules for declaring variables and host structures. When the statement is executed, a reference to a structure is replaced by a reference to each of its variables. The number of variables must be the same as the number of parameter markers in the prepared statement. The *n*th variable corresponds to the *n*th parameter marker in the prepared statement. Where appropriate, locator variables and file reference variables can be provided as the source of values for parameter markers. A global variable must not be specified.

An array global variable must only be specified if the EXECUTE statement is issued in SQL PL.

array-variable[array-index]

Identifies an array element. An array element must only be specified if the EXECUTE statement is issued in SQL PL.

array-variable

Specifies an array variable.

[*array-index*]

An expression that specifies which element in the array to use.

For an ordinary array, the array index expression must be castable to INTEGER, and must not be the null value. The index value must be between 1 and the maximum cardinality that is defined for the array.

For an associative array, the array index expression must be castable to the index data type of the associative array, and must not be the null value.

array-index must not be:

- An expression that references the CURRENT DATE, CURRENT TIME, or CURRENT TIMESTAMP special register
- A nondeterministic function
- A function that is defined with EXTERNAL ACTION
- A function that is defined with MODIFIES SQL DATA
- A sequence expression

array-variable

Specifies an array variable.

USING DESCRIPTOR *descriptor-name*

Identifies an SQLDA that contains a valid description of the input host variables.

Before invoking the EXECUTE statement, you must set the following fields in the SQLDA:

- SQLN to indicate the number of SQLVAR occurrences that are provided in the SQLDA
A REXX SQLDA does not contain this field.
- SQLABC to indicate the number of bytes of storage that are allocated for the SQLDA
- SQLD to indicate the number of variables that are used in the SQLDA when processing the statement
- SQLVAR entries to indicate the attributes of the variables

The SQLDA must have enough storage to contain all SQLVAR entries. If an SQLVAR entry includes a LOB value or a distinct type based on a LOB, there must be additional SQLVAR entries for each parameter. For more information on the SQLDA, which includes a description of the SQLVAR and an explanation on how to determine the number of SQLVAR entries, see [Appendix G, “SQL descriptor area \(SQLDA\),” on page 2313](#).

SQLD must be set to a value that is greater than or equal to zero and less than or equal to SQLN. It must be the same as the number of parameter markers in the prepared statement. The *n*th variable described by the SQLDA corresponds to the *n*th parameter marker in the prepared statement.

See [“Identifying an SQLDA in C or C++” on page 2329](#) for how to represent *descriptor-name* in C.

source-row-data

The prepared statement must be an INSERT or MERGE statement for which the FOR MULTIPLE ROWS clause is specified as part of the ATTRIBUTES clause on the PREPARE statement.

USING *host-variable-array* or *host-variable*

Introduces a list of host variables or host-variable arrays whose values are substituted for the parameter markers (question marks) in the prepared INSERT or MERGE statement. The number of columns specified in the INSERT or MERGE statement must be less than or equal to the total number of host variables or host-variable arrays that are specified.

host-variable-array

Identifies a host-variable array that must be defined in the application program in accordance with the rules for declaring a host-variable array. A reference to a structure is replaced by a reference to each of its variables. The number of variables must be the same as the number of parameter markers in the prepared statement. The *n*th variable supplies the value for the *n*th parameter marker in the prepared statement.

host-variable-array is supported in C/C++, COBOL, and PL/I. For more information, see [“Host-variable arrays in PL/I, C, C++, and COBOL” on page 236](#).

host-variable

Identifies a variable that must be described in the application program in accordance with the rules for declaring host variables.

USING DESCRIPTOR *descriptor-name*

Identifies an SQLDA that must contain a valid description of the host-variable arrays or host variables that contain the values to insert.

Before invoking the EXECUTE statement for a dynamic INSERT or MERGE statement, you must set the following fields in the SQLDA:

- SQLN to indicate the number of SQLVAR entries that are provided in the SQLDA.
- SQLABC to indicate the number of bytes of storage that are allocated for the SQLDA.
- SQLD to indicate the number of variables, plus one, that are used in the SQLDA that provide values for columns that are the source of the INSERT or MERGE statement. SQLD must be set to a value that is greater than or equal to zero and less than or equal to SQLN.

- SQLVAR entries to indicate the attributes of an element of the host-variable array for the SQLVAR entries that correspond to values that are provided for the source columns of the INSERT or MERGE statement. Within each SQLVAR, the following fields are set:
 - SQLTYPE indicates the data type of the elements of the host-variable array.
 - SQLDATA points to the corresponding host-variable array.
 - SQLLEN and SQLLONGLEN indicate the length of a single element of the array.
- SQLNAME, the fifth and sixth bytes must contain a flag field and the seventh and eighth bytes must contain a binary small integer (halfword) that contains the dimension of the host-variable array and, if specified, the corresponding indicator array.

The SQLDA must have enough storage to contain a SQLVAR entry for each target column for which values are provided, plus an additional SQLVAR entry for the number of rows. The Db2 system generates code to enter the required information for this extra SQLVAR entry. Each SQLVAR entry describes a host variable, host-variable array, or buffer that contains the values for a column of the source table. The last SQLVAR entry contains the number of rows of data. For example, if the INSERT or MERGE statement is providing values for five columns of the target table, six SQLVAR entries must be provided. If any value is a LOB value, twice as many SQLVAR entries must be provided, and SQLN must be set to the number of SQLVAR entries. Thus, if the INSERT or MERGE statement is providing values for five columns of the source table, and some of the values to insert are LOB values, 12 SQLVAR entries must be provided.

The SQLVAR entry for the number of rows must also contain a flag value. See [“Field descriptions of an occurrence of a base SQLVAR” on page 2317](#) for more information.

You set the SQLDATA and SQLIND pointers to the beginning of the corresponding arrays.

FOR n ROWS

Specifies the number of rows of source data, where *n* is *host-variable* or *integer-constant*. The values for the insert or merge operation are specified in the USING clause.

host-variable or *integer-constant* is assigned to an integral value *k*. If *host-variable* is specified, it must be an exact numeric type with a scale of zero and must not include an indicator variable. *k* must be in the range 0 to 32767.

FOR n ROWS cannot be specified on the EXECUTE statement if the statement being processed is a dynamic INSERT or MERGE statement that includes a FOR n ROWS clause.

Notes for EXECUTE

Excessive processor time:

Db2 can stop the execution of a prepared SQL statement if the statement is taking too much processor time to finish. When this happens, an error occurs. The application that issued the statement is not terminated; it is allowed to issue another SQL statement.

Parameter marker replacement:

Before the prepared statement is executed, each parameter marker in the statement is effectively replaced by its corresponding host variable. The replacement is an assignment operation in which the source is the value of the host variable and the target is a variable within Db2. The assignment rules are those described for assignment to a column in [“Assignment and comparison” on page 143](#). For a typed parameter marker, the attributes of the target variable are those specified by the CAST specification. For an untyped parameter marker, the attributes of the target variable are determined according to the context of the parameter marker. For the rules that affect parameter markers, see [Parameter markers](#).

Let V denote a host variable that corresponds to parameter marker P. The value of V is assigned to the target variable for P in accordance with the rules for assigning a value to a column:

- V must be compatible with the target.
- If V is a string, its length must not be greater than the length attribute of the target.

- If V is a number, the absolute value of its integral part must not be greater than the maximum absolute value of the integral part of the target.
- If the attributes of V are not identical to the attributes of the target, the value is converted to conform to the attributes of the target.
- If the target cannot contain nulls, V must not be null.

When the prepared statement is executed, the value used in place of P is the value of the target variable for P. For example, if V is CHAR(6) and the target is CHAR(8), the value used in place of P is the value of V padded on the right with two blanks.

Errors occurring on EXECUTE:

In local and remote processing, the DEFER(PREPARE) and REOPT(ALWAYS)/REOPT(ONCE) bind options can cause some errors that are normally issued during PREPARE processing to be issued on EXECUTE.

Considerations for executing data definition statements written in native SQL language:

A data definition statement written in native SQL language can only be executed one time. To execute the data definition statement multiple times, issue the PREPARE statement prior to each use of the EXECUTE statement for the data definition statement.

Examples for EXECUTE

Example 1

In this example, an INSERT statement with parameter markers is prepared and executed. S1 is a structure that corresponds to the format of DSN8C10.DEPT.

```
EXEC SQL PREPARE DEPT_INSERT FROM
  'INSERT INTO DSN8C10.DEPT VALUES(?,?,?,?)';
-- Check for successful execution and read values into S1
EXEC SQL EXECUTE DEPT_INSERT USING :S1;
```

Example 2

Assume that the IWH.PROGPARM table has 9 columns. Prepare and execute a dynamic INSERT statement that inserts 5 rows of data into the IWH.PROGPARM table. The values to be inserted are provided in arrays, where all the values for a column are provided in an host-variable-array with the EXECUTE statement.

```
STMT = 'INSERT INTO IWH.PROGPARM (IWHID, UPDATE_BY, UPDATE_TS, NAME,
                                SHORT_DESCRIPTION, ORDERNO, PARMDATA,
                                PARMDATALONG, VWPROGKEY)
VALUES ( ?, ?, ?, ?, ?, ?, ?, ?, ? )';
ATTRVAR = 'FOR MULTIPLE ROWS';
EXEC SQL PREPARE INS_STMT ATTRIBUTES :ATTRVAR FROM :STMT;
NROWS = 5;
EXEC SQL EXECUTE INS_STMT FOR :NROWS ROWS
      USING :V1, :V2, :V3, :V4, :V5, :V6, :V7, :V8, :V9;
```

In this example, each host variable in the USING clause represents an array of values for the corresponding column of the target of the INSERT statement.

Example 3

Using dynamically supplied values for an employee row, update the master EMPLOYEE table if the data is for an existing employee or insert a new row if the data is for a new employee.

```
hv_stmt =
"MERGE INTO EMPLOYEE AS T
  USING (VALUES (CAST (? AS CHAR(6)), CAST (? AS VARCHAR(12)),
                CAST (? AS CHAR(1)), CAST (? AS VARCHAR(15)),
                CAST (? AS INTEGER)))
  AS S (EMPNO, FIRSTNAME, MI, LASTNAME, SALARY)
  ON T.EMPNO = S.EMPNO
  WHEN MATCHED THEN UPDATE
    SET SALARY = S.SALARY
  WHEN NOT MATCHED THEN INSERT (EMPNO, FIRSTNAME, MI, LASTNAME, SALARY)
  VALUES (S.EMPNO, S.FIRSTNAME, S.MI, S.LASTNAME, S.SALARY)
  NOT ATOMIC CONTINUE ON SQLEXCEPTION";
```

```

hv_attr = 'FOR MULTIPLE ROWS';
EXEC SQL
  PREPARE merge_stmt
  ATTRIBUTES :hv_attr FROM :hv_stmt;
hv_nrows = 5;
/* Initialize the hostvar array of hv_empno, hv_firstname... */
EXEC SQL
  EXECUTE merge_stmt
  USING :hv_empno, :hv_firstname, :hv_mi,
        :hv_lastname, :hv_salary
  FOR :hv_nrows ROWS;

```

Example 4

Suppose that the following array type, array variable, and table have been defined.

```

CREATE TYPE INTARRAY AS INTEGER ARRAY[100];
CREATE TYPE STRINGARRAY AS VARCHAR(10) ARRAY[100];
CREATE TABLE T1 (COL1 CHAR(10), COL2 INT);

```

Use as an array variable as an input value for an expression in an EXECUTE statement.

```

CREATE PROCEDURE PROCESSPERSONS (OUT WITHO STRINGARRAY, INOUT INTO INT)
BEGIN
  DECLARE INTA INTARRAY;
  DECLARE STMT CHAR(100);
  -- Initialize the array
  SET INTA = ARRAY[1,INTEGER(2),3+0,4,5,6] ;
  -- Use dynamic sql with an array parameter marker to
  -- provide a value for a dynamic INSERT statement
  SET STMT = 'INSERT INTO T1 VALUES('XYZ', CARDINALITY(CAST(? AS INTARRAY)))';
  PREPARE INS_STMT FROM STMT;
  EXECUTE INS_STMT USING INTA;
  -- INTA is an array variable used as input for the
  -- INSERT statement
  ...
END

```

EXECUTE IMMEDIATE statement

EXECUTE IMMEDIATE combines the basic functions of the PREPARE and EXECUTE statements. It can be used to prepare and execute an SQL statement that contains neither host variables nor parameter markers.

The EXECUTE IMMEDIATE statement:

- Prepares an executable form of an SQL statement from a string form of the statement
- Executes the SQL statement
- Destroys the executable form

Invocation for EXECUTE IMMEDIATE

This statement can only be embedded in an application program. It is an executable statement that cannot be dynamically prepared. It must not be specified in Java.

Authorization for EXECUTE IMMEDIATE

The authorization rules are those defined for the dynamic preparation of the SQL statement specified by EXECUTE IMMEDIATE. For example, see [“INSERT statement” on page 1996](#) for the authorization rules that apply when an INSERT statement is executed using EXECUTE IMMEDIATE.

Syntax for EXECUTE IMMEDIATE

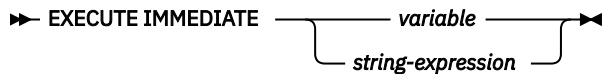

Description for EXECUTE IMMEDIATE

variable

For languages other than PL/I, *variable* must be specified. It must identify a variable that is described in the application program in accordance with the rules for declaring character or graphic string variables. If the source string is over 32KB in length, the *variable* must be a CLOB or DBCLOB variable. The maximum source length is 2MB, although the variable can be declared larger than 2MB. An indicator variable must not be specified with a host variable. In Assembler, C, COBOL, and PL/I, a host variable must be a varying-length string variable. In C, it must not be a NUL-terminated string. In SQL PL, an SQL variable, SQL parameter, or transition variable can be used, and the value must not be null.

string-expression

string-expression is any PL/I expression that yields a string. *string-expression* cannot be preceded by a colon. Variables that are within *string-expression* that include operators or functions should not be preceded by a colon. When *string-expression* is specified, the precompiler-generated structures for *string-expression* use an EBCDIC CCSID and an informational message is returned.

Notes for EXECUTE IMMEDIATE

Rules for statement strings:

The value of the identified host variable or the specified *string-expression* is called the *statement string*.

The statement string must be one of the following SQL statements, and cannot be a *select-statement*:

Statements	Statements
<ul style="list-style-type: none"> • ALLOCATE CURSOR • ALTER • ASSOCIATE LOCATORS • COMMENT • COMMIT • CREATE • DECLARE GLOBAL TEMPORARY TABLE • DELETE • DROP • EXPLAIN • FREE LOCATOR • GRANT • HOLD LOCATOR • INSERT • LABEL • LOCK TABLE • MERGE 	<ul style="list-style-type: none"> • SET CURRENT APPLICATION COMPATIBILITY • SET CURRENT DEGREE • SET CURRENT DECFLOAT ROUNDING MODE • SET CURRENT DEBUG MODE • SET CURRENT EXPLAIN MODE • SET CURRENT LOCALE LC_CTYPE • SET CURRENT MAINTAINED TABLE TYPES FOR OPTIMIZATION • SET CURRENT OPTIMIZATION HINT • SET CURRENT PRECISION • SET CURRENT QUERY ACCELERATION • SET CURRENT REFRESH AGE • SET CURRENT ROUTINE VERSION • SET CURRENT RULES • SET CURRENT SQLID • SET ENCRYPTION PASSWORD • SET PATH • SET SCHEMA

Statements	Statements
<ul style="list-style-type: none"> • REFRESH TABLE • RELEASE SAVEPOINT • RENAME • REVOKE • ROLLBACK • SET <i>assignment-statement</i> • SAVEPOINT • SET CURRENT ACCELERATOR 	<ul style="list-style-type: none"> • SET CURRENT TEMPORAL BUSINESS_TIME • SET CURRENT TEMPORAL SYSTEM_TIME • SET SESSION TIME ZONE • SIGNAL • TRANSFER OWNERSHIP • TRUNCATE • UPDATE

The statement string must not have any of the following attributes:

- Begin with EXEC SQL
- End with END-EXEC or a semicolon
- Include references to variables, other than global variables
- Include parameter markers
- Include references to transition tables

Errors and error handling:

When an EXECUTE IMMEDIATE statement is executed, the specified statement string is parsed and checked for errors. If the SQL statement is invalid, it is not executed and the error condition that prevents its execution is reported in the SQLCA. If the SQL statement is valid, but an error occurs during its execution, that error condition is reported in the SQLCA.

Db2 can stop the execution of a prepared SQL statement if the statement is taking too much CPU time to finish. When this happens an error occurs. The application that issued the statement is not terminated; it is allowed to issue another SQL statement.

Effect of the CURRENT EXPLAIN MODE special register:

If the CURRENT EXPLAIN MODE special register is set to EXPLAIN, the statement is prepared for explain only and is not executable, unless the statement is a SET statement. Attempting to execute the prepared statement will return an error. See the [“CURRENT EXPLAIN MODE special register”](#) on page 194 special register for more information.

Performance considerations:

If the same SQL statement is to be executed more than once, it is more efficient to use the PREPARE and EXECUTE statements rather than the EXECUTE IMMEDIATE statement.

Examples for EXECUTE IMMEDIATE

Example 1

In this PL/I example, the EXECUTE IMMEDIATE statement is used to execute a DELETE statement in which the rows to be deleted are determined by a search-condition specified by the value of PRED5.

```
EXEC SQL EXECUTE IMMEDIATE 'DELETE FROM DSN8C10.DEPT
WHERE' || PRED5;
```

Example 2

Use C to execute the SQL statement in the host variable Qstring.

```
EXEC SQL INCLUDE SQLCA;
void main ()
{
EXEC SQL BEGIN DECLARE SECTION;
char Qstring[100] =
"INSERT INTO WORK_TABLE SELECT * FROM EMPPROJECT WHERE ACTNO >= 100";
```



```

EXEC SQL END DECLARE SECTION;
.
.
EXEC SQL EXECUTE IMMEDIATE :Qstring;
return;
}

```

:

EXPLAIN statement

The EXPLAIN statement obtains information about access path selection for an *explainable statement*. A statement is explainable if it is a SELECT, MERGE, TRUNCATE, or INSERT statement, or the searched form of an UPDATE or DELETE statement. The information that is obtained is placed in a set of supplied user tables that are called *EXPLAIN tables*.

PSPI

The *plan table* contains information about the access path for the specified statement or statements. The *statement table* can be populated with information about the estimated cost of executing the explainable statement. The *function table* can be populated with information about how Db2 resolves the user-defined functions that are referred to in the explainable statement. Other EXPLAIN tables can be populated with additional information about the execution of the explainable statement. For a complete list of EXPLAIN tables, see [EXPLAIN tables \(Db2 Performance\)](#).

Using EXPLAIN for queries that reference system-period temporal tables that are enabled for system data versioning, the result will show the system-period temporal tables and the history tables in EXPLAIN output if the query needs to reference both tables to satisfy the query.

Invocation for EXPLAIN

This statement can be embedded in an application program or issued interactively. It is an executable statement that can be dynamically prepared.

Authorization for EXPLAIN

The authorization rules are those defined for the SQL statement specified in the EXPLAIN statement. For example, see the description of the DELETE statement for the authorization rules that apply when EXPLAIN records are captured for DELETE statements.

If the EXPLAIN statement is embedded in an application program, the authorization rules that apply are those defined for embedding the specified SQL statement in an application program. In addition, the owner of the plan or package must also have one of the following characteristics:

- Be the owner of a plan table named PLAN_TABLE
- Have an alias on a plan table named *owner*.PLAN_TABLE and have SELECT and INSERT privileges on the table

If the EXPLAIN statement is dynamically prepared, the authorization rules that apply are those defined for dynamically preparing the specified SQL statement. In addition, the SQL authorization ID of the process or the role this is associated with the process (if the EXPLAIN statement is running in a trusted context that specifies the ROLE AS OBJECT OWNER AND QUALIFIER clause) must also have one of the following characteristics:

- Be the creator of a plan table named PLAN_TABLE
- Have an alias on a plan table named *creator*.PLAN_TABLE and have SELECT and INSERT privileges on the table

For EXPLAIN statements with the PLAN and ALL keywords, the privilege set that is defined below must include at least one of the following:

- EXPLAIN

- SQLADM
- System DBADM
- The authorization rules that are defined for the SQL statement specified in the EXPLAIN statement. For example, the authorization rules that apply when EXPLAIN records are captured for a DELETE statement are the authorization rules for the DELETE statement.

The authorization rules are different if the STMTCACHE or STABILIZED DYNAMIC QUERY keywords are specified. The privilege set must include at least one of the following:

- SQLADM authority
- SYSADM authority
- The authority that is required to share the cached statement.
- System DBADM authority

For EXPLAIN statements that contain the STMTCACHE ALL clause, the privilege set must include at least one of the following:

- SQLADM authority
- System DBADM authority
- SYSADM authority

If the privilege set does not have the required authority, EXPLAIN records are captured only those statements that have the same authorization ID as the privilege set.

For the PACKAGE keyword, the privilege set must include at least one of the following:

- SQLADM authority
- SYSADM authority
- SYSOPR authority
- SYSCTRL authority

Privilege set: The privilege set comprises the union of authorities that are held by the authorization IDs of the process. If the process is running in a trusted context with a role, this role would be included as an authorization ID of the process.

Syntax for EXPLAIN

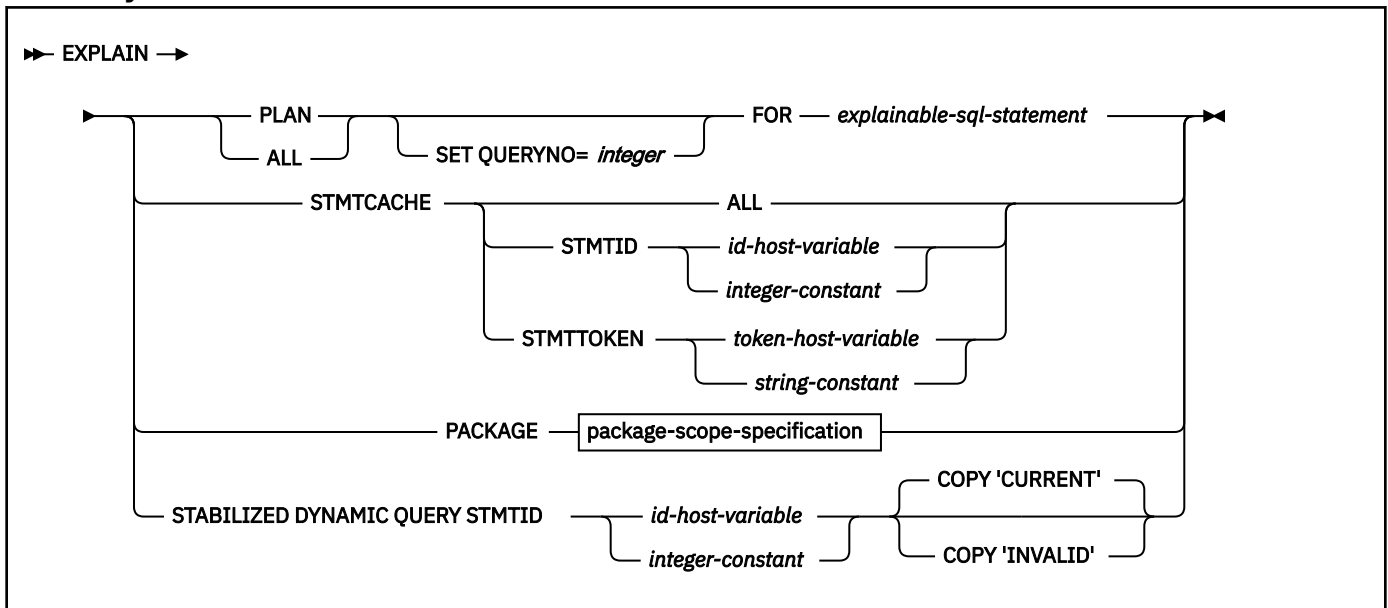

package-scope-specification:

► COLLECTION — *collection-name* — PACKAGE — *package-name* ►

┌── VERSION — *version-name* ─┐ ┌── COPY — *copy-id* ─┐
└────────────────────────────────┘ └────────────────────────────────┘

Description for EXPLAIN

PLAN

Specifies that access path information is captured for the SQL statement. Under this option, Db2 uses the access path selection process to generate the EXPLAIN records for the statement.

One row is inserted into the PLAN_TABLE for each step used in executing *explainable-sql-statement*. The steps for enforcing referential constraints are not included.

If a statement table exists, one row that provides a cost estimate of processing the explainable statement is inserted into the statement table. If the explainable statement is a SELECT FROM *data-change-statement*, two rows are inserted into the statement table.

If a function table exists, one row is inserted into the function table for each user-defined function that is referred to by the explainable statement.

If additional EXPLAIN tables exist, rows are also inserted into those tables.

For more information, see:

[EXPLAIN tables \(Db2 Performance\)](#)

[PLAN_TABLE \(Db2 Performance\)](#)

[DSN_STATEMNT_TABLE \(Db2 Performance\)](#)

[DSN_FUNCTION_TABLE \(Db2 Performance\)](#)

ALL

Has the same effect as PLAN.

SET QUERYNO = *integer*

Associates *integer* with *explainable-sql-statement*. The column QUERYNO is given the value *integer* in every row inserted into the plan table, statement table, or function table by the EXPLAIN statement.

If QUERYNO is not specified, Db2 itself assigns a number. For an embedded EXPLAIN statement, the number is the statement number that was assigned by the precompiler and placed in the DBRM.

FOR *explainable-sql-statement*

Specifies the text of an SQL statement for which EXPLAIN records are captured. *explainable-sql-statement* can be any explainable SQL statement. A statement is explainable if it is a SELECT, MERGE, TRUNCATE, or INSERT statement, or the searched form of an UPDATE or DELETE statement. If the EXPLAIN statement is embedded in a program, the statement can contain references to host variables. If EXPLAIN is dynamically prepared, the statement can contain parameter markers. Host variables that appear in the statement must be defined in the statement's program.

The statement must refer to objects at the current server.

explainable-sql-statement must not contain a QUERYNO clause. To specify the value of the QUERYNO column, use the SET QUERYNO = *integer* clause of the EXPLAIN statement.

explainable-sql-statement cannot be a statement-name or a host-variable. To use capture EXPLAIN records for dynamic SQL statements, you must prepare the entire EXPLAIN statement dynamically.

To obtain information about an explainable SQL statement that references a declared temporary table, the EXPLAIN statement must be executed in the same application process in which the table was declared. For static EXPLAIN statements, the information is not obtained at bind-time but at run time when the EXPLAIN statement is incrementally bound.

STMTCACHE

Specifies that EXPLAIN records for the specified dynamic SQL statements in the dynamic statement cache are extracted and written to EXPLAIN tables. Under this option, no new access path selection processing occurs. The EXPLAIN records are extracted from the existing access paths that were selected when the dynamic SQL statements were prepared and entered the statement cache. In a data-sharing environment, the EXPLAIN records are extracted from the dynamic statement cache of the data sharing member where EXPLAIN STMTCACHE statement is executed.

ALL

Specifies that EXPLAIN records are extracted for all cached statements. STMTCACHE ALL returns one row for each cached statement to the DSN_STATEMENT_CACHE_TABLE. These rows contain identifying information about the statements in the cache, as well as statistics that reflect the execution of the statements by all processes that have executed the statement. Records are not returned to other EXPLAIN tables when STMTCACHE ALL is specified.

STMTID *id-host-variable* or *integer-constant*

Specifies that EXPLAIN records are extracted for the cached statement with the specified statement ID. The value contained in *id-host-variable* or specified by *integer-constant* identifies the statement ID. STMTCACHE STMTID returns rows to the following EXPLAIN tables:

- PLAN_TABLE
- DSN_STATEMNT_TABLE
- DSN_FUNCTION_TABLE
- DSN_STATEMENT_CACHE_TABLE

The statement ID is an integer that uniquely identifies a statement that has been cached in the dynamic statement cache. The statement ID of a cached statement can be retrieved through IFI monitor facilities from IFCID 316 or 124. Some diagnostic trace records, such as IFCIDs 0173, 0196, and 0337, also show the statement ID.

The QUERYNO column of each EXPLAIN table record that is returned contains the statement ID value.

STMTTOKEN *id-host-variable* or *string-constant*

Specifies that EXPLAIN records are extracted for the cached statements with the specified statement token and written to certain EXPLAIN tables. The value contained in *token-host-variable* or specified by *string-constant* identifies the statement token. STMTCACHE STMTTOKEN writes records to the following EXPLAIN tables:

- PLAN_TABLE
- DSN_STATEMNT_TABLE
- DSN_FUNCTION_TABLE
- DSN_STATEMENT_CACHE_TABLE

The statement token must be a character string that is no longer than 240 bytes. The application program that originally prepares and inserts a statement into the cache associates a statement token with the cached statement. The program can make this association with the RRSF SET_ID function, or the sqleseti API if the program is connected remotely.

The STMTTOKEN column of each PLAN_TABLE record that is returned contains the statement token value. The QUERYNO column of each EXPLAIN table record that is returned contains the statement ID value.

For more information, see:

[DSN_STATEMENT_CACHE_TABLE \(Db2 Performance\)](#)
[Capturing reoptimized access paths \(Db2 Performance\)](#)

PACKAGE

Specifies that EXPLAIN records for all static SQL statements in the package that matches the specified scope are extracted and written to EXPLAIN tables. Under this option, no new access path selection processing occurs. The records are extracted from the existing access paths that were

selected when the package was bound. The EXPLAIN information is added to the PLAN_TABLE that is owned by the current user. Other EXPLAIN tables are not populated.

COLLECTION *collection-name*

Specifies that EXPLAIN records are captured only for statements under the specified *collection-name*. *collection-name* is a string constant or a host variable that represents the collection name.

PACKAGE *package-name*

Specifies that EXPLAIN records are captured only for statements under the specified *package-name*. *package-name* is a string constant or a host variable that represents the package name.

VERSION *version-name*

Specifies that EXPLAIN records are captured only for statements under the specified *version-name*. *version-name* is a string constant or a host variable that represents the version name. If *version-name* is all blanks or an empty string, records are captured only for those versions of the package that contain all blanks for the version name.

If the VERSION clause is not specified, EXPLAIN records are captured for statements in all versions of the package *package-name*.

COPY *copy-id*

Specifies that EXPLAIN records are captured only for statements under the specified *copy-id*. *copy-id* must be one of the following values:

- CURRENT
- PREVIOUS
- ORIGINAL

If the COPY clause is not specified, statements, EXPLAIN records are captured for the current, previous, and original copies that exist for that package.

The HINT_USED column in the PLAN_TABLE is populated with EXPLAIN PACKAGE: *copy-id*. *copy-id* in the HINT_USED column will be one of the following values:

- "CURRENT" - the current copy
- "PREVIOUS" - the previous copy
- "ORIGINAL" - the original copy

STABILIZED DYNAMIC QUERY

Specifies that the explain records for the stabilized dynamic statement identified by the STMTID keyword are extracted and written to the following EXPLAIN tables:

- PLAN_TABLE
- DSN_STATEMNT_TABLE
- DSN_FUNCTION_TABLE

STMTID *id-host-variable or integer-constant*

Specifies that EXPLAIN information is captured for the statement with the specified statement identifier. This value is inserted into the PER_STMT_ID column of the EXPLAIN tables.

COPY *copy-id*

Specifies that EXPLAIN information is captured only for statements under the specified copy identifier value. *copy-id* is a string constant and must be one of the following values:

- CURRENT
- INVALID

The PLAN_TABLE.HINT_USED column is populated with the string 'EXPLAIN SDQ: *copy-id-number*' where *copy-id-number* is one of the following values:

CURRENT

The current copy.

INVALID

The invalid copy.

The QUERYNO column of each EXPLAIN table record that is returned is set to the default value 0, and the value of the COLLID column is set to 'DSNSTBLQRYEXPLAIN.'

Notes for EXPLAIN

Output from EXPLAIN:

Db2 inserts one or more rows of data into a plan table and other existing *EXPLAIN tables*.

For a list of all EXPLAIN tables, see [EXPLAIN tables \(Db2 Performance\)](#).

A plan table must exist before the operation that results in EXPLAIN output. You can find a sample CREATE TABLE statement for each EXPLAIN table in member DSNTESC of the *prefix.SDSNSAMP* library.

Unless you need the information that is provided by the additional EXPLAIN tables, it is not necessary to create those tables to use EXPLAIN. However, a statement cache table is required when the STMTCACHE ALL keyword is specified as part of an EXPLAIN statement.

Db2 uses the access path selection process to generate EXPLAIN records only for certain types of EXPLAIN statements, as shown in the following table.

Table 232. Origin of EXPLAIN records for various EXPLAIN statement options

Options Specified	How Db2 Creates EXPLAIN records
EXPLAIN PLAN FOR <i>explainable-sql-statement</i>	Uses the access path selection process to generate the EXPLAIN records
EXPLAIN PACKAGE ...	Extracts existing access path information from the package to create the EXPLAIN records.
EXPLAIN STMTCACHE ...	Extracts access path information from the dynamic statement cache to create the EXPLAIN records.
EXPLAIN STABILIZED DYNAMIC QUERY ...	Extracts access path information from catalog tables for the specified stabilized dynamic SQL statements.

Each row in an EXPLAIN table describes some aspect of a step in the execution of a query or subquery in an explainable statement. The column values for the row identify, among other things, the query or subquery, the tables and other objects involved, the methods used to carry out each step, and cost information about those methods.

Instances of these tables might also be created and used by certain optimization tools. For information about the meanings of different values in plan table and other EXPLAIN tables, see .

For information about how to correlate information across EXPLAIN tables, see [Correlating information across EXPLAIN tables \(Db2 Performance\)](#).

EXPLAIN tables might contain names that begin with "DSN" that have been generated by Db2.

Important: Do not manually manipulate the data in EXPLAIN tables that are created by optimization tools.

Column access control or row permissions enforced for EXPLAIN tables:

Column access control and row permissions can be enforced for EXPLAIN tables. However, row permissions and column masks are not applied when Db2 inserts rows into those tables.

If the specified statement references tables for which row or column access control is activated, the following information from row permission and column mask definitions created for the tables might appear in the EXPLAIN tables:

- DSN_FUNCTION_TABLE - user-defined functions
- DSN_PREDICAT_TABLE - predicates (except predicates in CASE WHEN clauses)
- DSN_STRUCT_TABLE - query blocks
- PLAN_TABLE - access path of subqueries

In addition, the complete or partial definition text might appear in EXPLAIN tables like DSN_FUNCTION_TABLE, DSN_PREDICAT_TABLE, DSN_QUERY_TABLE, DSN_SORTKEY_TABLE, DSN_STATEMENT_CACHE_TABLE, and DSN_STATEMENT_RUNTIME_INFO.

Impact to the existing access paths when the table has enforced column access control or row permissions:

The predicates from the row permissions are considered in the access path selection. Therefore, they are shown in the EXPLAIN tables for the performance tuning purpose.

Impact to EXPLAIN tables when referencing a non-existing object in a dynamic SQL statement

In some situations in which EXPLAIN is run on a dynamic SQL statement that references a non-existing object, a SQLCODE -204 is issued to indicate that the object is not defined in the Db2 subsystem. However, changes to the related EXPLAIN tables might not be rolled back.

Considerations when capturing EXPLAIN records for the acceleration of rowset queries:

A rowset query cannot be passed to an accelerator server for processing in the following cases:

- If the rowset query is run remotely
- If the rowset query is declared WITH RETURN
- If the rowset query is run under an SQL PL routine

You cannot use a static EXPLAIN statement to determine whether a rowset query is passed to an accelerator server, because you cannot specify the WITH ROWSET POSITIONING cursor attribute for a static EXPLAIN statement. Instead, you must use a dynamic EXPLAIN statement, where the WITH ROWSET POSITIONING clause is specified in the attribute string. You also can specify the WITH RETURN clause in the attribute string to see the ineligibility of result sets.

Also, the EXPLAIN statement cannot be used to determine that a rowset query cannot be passed to an accelerator server because the query is being run remotely or under an SQL PL routine. If the PREPARE of the EXPLAIN statement is run locally, Db2 determines if the rowset query can be accelerated as a local query offload. However, if the PREPARE of the EXPLAIN statement runs remotely, Db2 indicates that the rowset query cannot be accelerated. Instead, you can use the CURRENT EXPLAIN MODE special register to determine the behavior for eligible dynamic SQL statements during application execution. For more information, see [“CURRENT EXPLAIN MODE special register” on page 194](#).

EXPLAIN tables

For a descriptions of the EXPLAIN tables, see [EXPLAIN tables \(Db2 Performance\)](#).

Examples for EXPLAIN

Example 1: Determine the steps required to execute the query 'SELECT X.ACTNO . . .'. Assume that no set of rows in the PLAN_TABLE has the value 13 for the QUERYNO column.

```
EXPLAIN PLAN SET QUERYNO = 13
FOR SELECT X.ACTNO, X.PROJNO, X.EMPNO, Y.JOB, Y.EDLEVEL
FROM DSN8C10.EMPPROJACT X, DSN8C10.EMP Y
WHERE X.EMPNO = Y.EMPNO
AND X.EMPTIME > 0.5
AND (Y.JOB = 'DESIGNER' OR Y.EDLEVEL >= 12)
ORDER BY X.ACTNO, X.PROJNO;
```

Example 2: Retrieve the information returned in Example 1. Assume that a statement table exists, so also retrieve the estimated cost of processing the query. Use the following query, which joins the plan table and the statement table.

```
SELECT * FROM PLAN_TABLE A, DSN_STATEMNT_TABLE B
WHERE A.QUERYNO = 13 and B.QUERYNO = 13
ORDER BY A.QBLOCKNO, A.PLANNO, A.MIXOPSEQ;
```

Example 3: Extract existing access path information to capture EXPLAIN records for the cached statement with statement ID 124. Assume that host variable SID contains 124.

```
EXPLAIN STMTCACHE STMTID :SID;
```

Example 4: Extract existing access path information to capture one row of EXPLAIN data for each statement in the dynamic statement cache. The records are written only to the DSN_STATEMENT_CACHE_TABLE.

```
EXPLAIN STMTCACHE ALL;
```

Example 5: Assume that you want to use the plan table that was created by ADMF001 and your authorization ID is SYSADM. If you have an alias on ADMF001.PLAN_TABLE (CREATE ALIAS SYSADM.PLAN_TABLE FOR ADMF001.PLAN_TABLE) and sufficient INSERT and SELECT privileges on the table, the following EXPLAIN statement will execute and ADMF001.PLAN_TABLE will be populated.

```
EXPLAIN PLAN SET QUERYNO = 101
FOR SELECT * FROM DSN8C10.EMP;
```

Example 6: Extract existing access path information to capture EXPLAIN records to the current user's PLAN_TABLE for all static SQL statements in the current copy of the package 'COLLA.PACK52604':

```
EXPLAIN PACKAGE COLLECTION 'COLLA' PACKAGE 'PACK52604' COPY 'CURRENT' ;
```

PSPI

Related concepts

[Interpreting data access by using EXPLAIN \(Db2 Performance\)](#)

Related tasks

[Checking how Db2 resolves functions by using DSN_FUNCTION_TABLE \(Db2 Application programming and SQL\)](#)

[Capturing access path information in EXPLAIN tables \(Db2 Performance\)](#)

Related reference

[“ADMIN_EXPLAIN_MAINT stored procedure” on page 751](#)

You can use the ADMIN_EXPLAIN_MAINT stored procedure to create EXPLAIN tables, upgrade the tables to the format for the current Db2 version, and complete other administrative tasks.

[EXPLAIN bind option \(Db2 Commands\)](#)

FETCH statement

The FETCH statement positions a cursor on a row of its result table. It can return zero, one, or multiple rows and assigns the values of the rows to variables if there is a target specification.

Invocation for FETCH

This statement can only be embedded in an application program. It is an executable statement that cannot be dynamically prepared. Multiple row fetch is not supported in REXX, Fortran, or SQL Procedure applications³⁵. The FETCH statement with the WITH CONTINUE clause is not supported in REXX.

³⁵ ASSEMBLER and other languages are supported, but this support is limited to statements that allow USING DESCRIPTOR. The precompiler does not recognize host-variable-arrays except in C/C++, COBOL, and PL/I.

Authorization for FETCH

See “[DECLARE CURSOR statement](#)” on page 1819 for an explanation of the authorization required to use a cursor.

For an assignment to a global variable or an element of an array global variable, the privilege set must include at least one of the following:

- The WRITE privilege on the variable
- Ownership of the variable
- DATAACCESS authority
- SYSADM authority

For an assignment to a transition variable, the privilege set must include at least one of the following:

- The UPDATE privilege on the table or view on which the trigger that contains the assignment statement is defined
- The UPDATE privilege on the column corresponding to the transition variable to be assigned a value
- Ownership of the table or view on which the trigger that contains the assignment statement is defined
- DBADM authority on the database that contains the table on which the trigger that contains the assignment statement is defined
- DATAACCESS authority
- SYSADM authority

Privilege set: If the statement is embedded in an application program, the privilege set is the privileges that are held by the owner of the package. If the statement is dynamically prepared, the privilege set is determined by the DYNAMICRULES behavior in effect (run, bind, define, or invoke) and is summarized in [DYNAMICRULES behaviors and authorization checking](#). For more information on these behaviors, including a list of the DYNAMICRULES bind option values that determine them, see “[Authorization IDs and dynamic SQL](#)” on page 94.

Syntax for FETCH

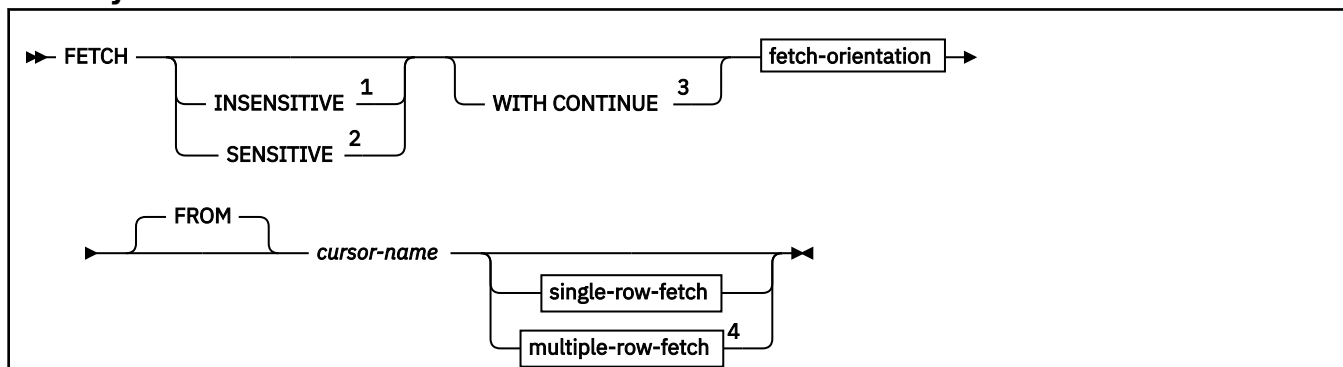

Notes:

- ¹ The default depends on the sensitivity of the cursor. If INSENSITIVE is specified on the DECLARE CURSOR, then the default is INSENSITIVE and if SENSITIVE is specified on the DECLARE CURSOR, then the default is SENSITIVE.
- ² If INSENSITIVE or SENSITIVE is specified, *single-row-fetch* or *multiple-row-fetch* must be specified.
- ³ If WITH CONTINUE is specified, *single-row-fetch* must be specified.
- ⁴ If *multiple-row-fetch* is specified, a *rowset-positioned* fetch orientation must also be specified.

fetch-orientation

»»

fetch-orientation

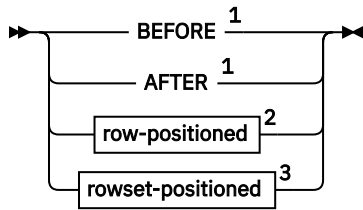

row-positioned

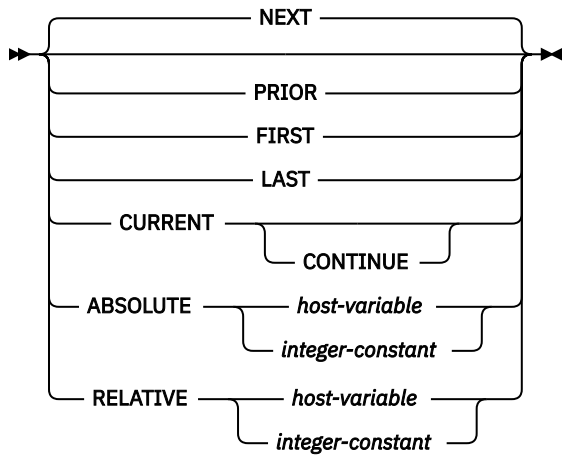

rowset-positioned

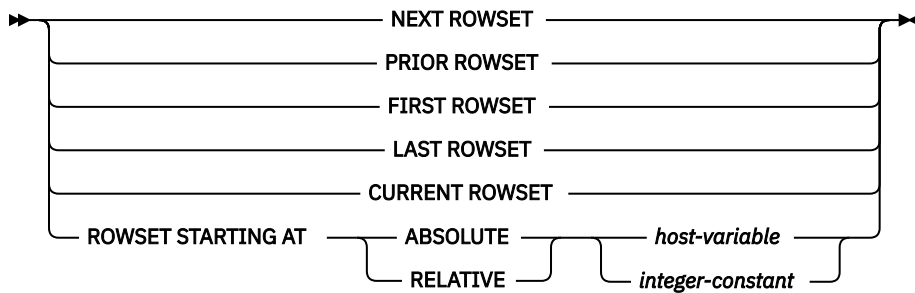

Notes:

- ¹ If BEFORE or AFTER is specified, SENSITIVE, INSENSITIVE, *single-row-fetch*, or *multiple-row-fetch* must not be specified.
- ² A row-positioned fetch orientation can be specified only if *multiple-row-fetch* is not specified.
- ³ If *multiple-row-fetch* is specified, a rowset-positioned fetch orientation must also be specified.

fetch-type

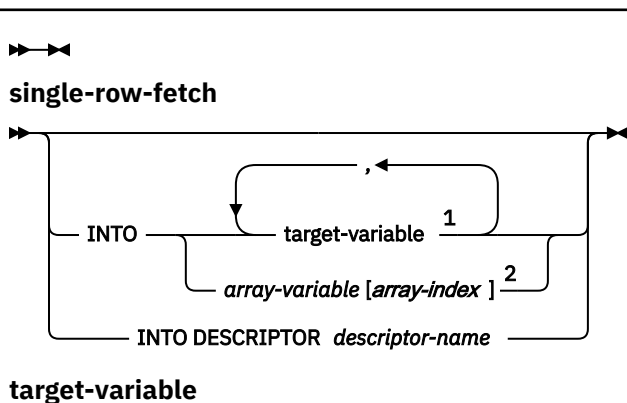

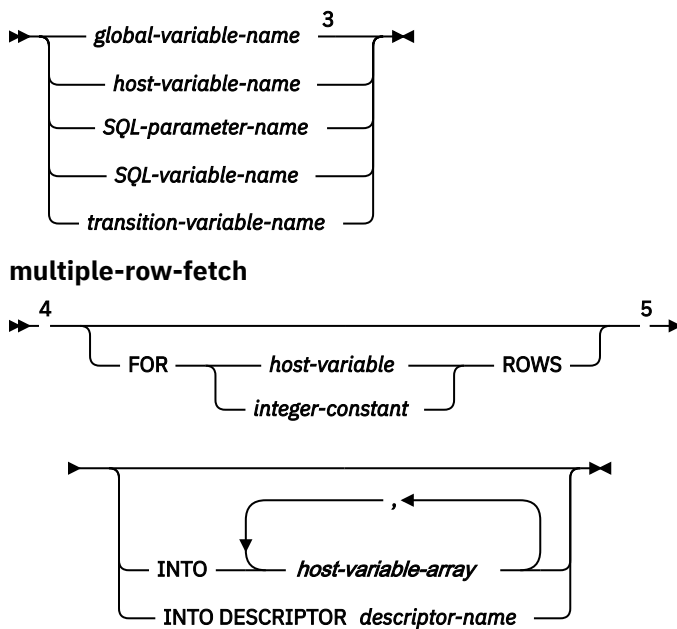

Notes:

- ¹ For single-row-fetch, a host-variable-array can be specified instead of a host variable. The descriptor can describe host-variable-arrays. In either case, data is returned only for the first entry of the host-variable-array.
- ² An array element must only be specified in an SQL PL context.
- ³ An array global variable must only be specified in an SQL PL context.
- ⁴ This clause must not be specified if a *row-positioned* fetch orientation or if no fetch orientation was specified.
- ⁵ This clause is optional. If this clause is not specified and either a rowset size has not been established yet or a row positioned FETCH statement was the last type of FETCH statement issued for this cursor, the rowset size is implicitly one. If the last FETCH statement issued for this cursor was a rowset positioned FETCH statement and this clause is not specified, the rowset size is the same size as the previous rowset positioned FETCH.

Description for FETCH

INSENSITIVE

Returns the row from the result table as it is. If the row has been previously fetched with a FETCH SENSITIVE, it reflects changes made outside this cursor before the FETCH SENSITIVE statement was issued. Positioned updates and deletes are reflected with FETCH INSENSITIVE if the same cursor was used for the positioned update or delete.

INSENSITIVE can only be specified for cursors declared as INSENSITIVE or SENSITIVE STATIC (or if the cursor is declared as ASENSITIVE and Db2 defaults to INSENSITIVE). Otherwise, if the cursor is declared as SENSITIVE DYNAMIC (or if the cursor is declared as ASENSITIVE and Db2 defaults to SENSITIVE DYNAMIC), an error occurs and the FETCH statement has no effect. For an INSENSITIVE cursor, specifying INSENSITIVE is optional because it is the default.

SENSITIVE

Updates the fetched row in the result table from the corresponding row in the base table of the cursor's SELECT statement and returns the current values. Thus, it reflects changes made outside this cursor. SENSITIVE can only be specified for a sensitive cursor. Otherwise, if the cursor is insensitive, an error occurs and the FETCH statement has no effect. For a SENSITIVE cursor, specifying SENSITIVE is optional because it is the default.

When the cursor is declared as SENSITIVE STATIC and a FETCH SENSITIVE is requested, the following steps are taken:

1. Db2 retrieves the row of the database that corresponds to the row of the result table that is about to be fetched.
2. If the corresponding row has been deleted, a "delete hole" occurs in the result table, a warning is issued, the cursor is repositioned on the "hole", and no data is fetched. (Db2 marks a row in the result table as a "delete hole" when the corresponding row in the database is deleted.)
3. If the corresponding row has not been deleted, the predicate of the underlying SELECT statement is re-evaluated. If the row no longer satisfies the predicate, an "update hole" occurs in the result table, a warning is issued, the cursor is repositioned on the "hole," and no data is fetched. (Db2 marks a row in the result table as an "update hole" when an update to the corresponding row in the database causes the row to no longer qualify for the result table.)
4. If the corresponding row does not result in a delete or an update hole in the result table, the cursor is repositioned on the row of the result table and the data is fetched.

WITH CONTINUE

Specifies that the Db2 subsystem should prepare to allow subsequent FETCH CURRENT CONTINUE operations to access any truncated LOB or XML result column following an initial FETCH operation that provides output variables that are not large enough to hold the entire LOB or XML columns. When the WITH CONTINUE clause is specified, the Db2 subsystem takes the following actions that can differ from the case where the FETCH statement does not include the WITH CONTINUE clause:

- If truncation occurs when returning an XML or LOB column, the Db2 subsystem will remember the truncation position and will not discard the remaining data.
- If truncation occurs when returning an XML or LOB column, the Db2 subsystem returns the total length that would have been required to hold all of the data of the LOB or XML column. This will either be in the first four bytes of the LOB host variable structure or in the 4 byte area that is pointed to by the SQLDATALEN pointer in the SQLVAR entry of the SQLDA for that host variable. What is returned depends on the programming method that is used. See [Appendix G, "SQL descriptor area \(SQLDA\)," on page 2313](#) for details about the SQLDA contents.
- If returning XML data, the result column will be fully materialized in the database before the data is returned.

If the CURRENT CONTINUE clause is specified, the WITH CONTINUE behavior is assumed.

AFTER

Positions the cursor after the last row of the result table. Values are not assigned to host variables. The number of rows of the result table are returned in the SQLERRD1 and SQLERRD2 fields of the SQLCA for cursors with an effective sensitivity of INSENSITIVE or SENSITIVE STATIC.

BEFORE

Positions the cursor before the first row of the result table. Values are not assigned to host variables.

row-positioned

Positioning of the cursor with row-positioned fetch orientations NEXT, PRIOR, CURRENT and RELATIVE is done in relation to the current cursor position. Following a successful row-positioned FETCH statement, the cursor is positioned on a single row of data. If the cursor is enabled for rowsets, positioning is performed relative to the current row or the first row of the current rowset, and the cursor is positioned on a rowset consisting of a single row.

NEXT

Positions the cursor on the next row or rows of the result table relative to the current cursor position, and returns data if a target is specified. NEXT is the only row-positioned fetch operation that can be explicitly specified for cursors that are defined as NO SCROLL. NEXT is the default if no other cursor positioning is specified. If a specified row reflects a hole, a warning is issued and data values are not assigned to host variables for that row.

[Table 233 on page 1929](#) lists situations for different cursor positions and the results when NEXT is used.

Table 233. Results when NEXT is used with different cursor positions

Current state of the cursor	Result of FETCH NEXT
Before the first row	Cursor is positioned on the first row ¹ on page 1929 and data is returned if requested.
On the last row or after the last row	A warning occurs, values are not assigned to host variables, and the cursor position is unchanged.
Before a hole	For a SENSITIVE STATIC cursor, a warning occurs for a delete hole or an update hole, values are not assigned to host variables, and the cursor is positioned on the hole.
Unknown	An error occurs, values are not assigned to host variables, and the cursor position remains unknown.

Note:

1. This row is not applicable in the case of a forward-only cursor (that is when NO SCROLL was specified implicitly or explicitly).

PRIOR

Positions the cursor on the previous row or rows of the result table relative to the current cursor position, and returns data if a target is specified. If a specified row reflects a hole, a warning is issued, and data values are not assigned to host variables for that row.

Table 234 on page 1929 lists situations for different cursor positions and the results when PRIOR is used.

Table 234. Results when PRIOR is used with different cursor positions

Current state of the cursor	Result of FETCH PRIOR
Before the first row or on the first row	A warning occurs, values are not assigned to host variables, and the cursor position is unchanged.
After a hole	For a SENSITIVE STATIC cursor, a warning occurs for a delete hole or an update hole, values are not assigned to host variables, and the cursor is positioned on the hole.
After the last row	Cursor is positioned on the last row.
Unknown	An error occurs, values are not assigned to host variables, and the cursor position remains unknown.

FIRST

Positions the cursor on the first row of the result table, and returns data if a target is specified. For a SENSITIVE STATIC cursor, if the first row of the result table is a hole, a warning occurs for a delete hole or an update hole and values are not assigned to host variables.

LAST

Positions the cursor on the last row of the result table, and returns data if a target is specified. The number of rows of the result table is returned in the SQLERRD1 and SQLERRD2 fields of the SQLCA for an insensitive or sensitive static cursor. For a SENSITIVE STATIC cursor, if the last row of the result table is a hole, a warning occurs for a delete hole or an update hole and values are not assigned to host variables.

CURRENT

The cursor position is not changed, data is returned if a target is specified. If the cursor was positioned on a rowset of more than one row, the cursor position is on the first row of the rowset.

Table 235 on page 1930 lists situations in which errors occur with the CURRENT clause.

Table 235. Situations in which errors occur with CURRENT

Current state of the cursor	Result of FETCH CURRENT
Before the first row or after the last row	A warning occurs, values are not assigned to host variables, and the cursor position is unchanged.
On a hole	<p>For a SENSITIVE STATIC, a warning occurs for a delete hole or an update hole, values are not assigned to host variables, and the cursor is positioned on the hole.</p> <p>If the cursor is defined as a rowset cursor, with isolation level UR or a sensitive dynamic scrollable cursor, it is possible that a different row will be returned than the FETCH that established the most recent cursor position. This can occur while fetching a row again when it is determined to not be there anymore. In this case, fetching continues moving forward to get the row of data.</p>
Unknown	An error occurs, values are not assigned to host variables, and the cursor position remains unknown.

CONTINUE

The cursor positioning is not changed, and data is returned if a target is specified. The FETCH CURRENT CONTINUE statement retrieves remaining data for any LOB or XML column result values that were truncated on a previous FETCH or FETCH CURRENT CONTINUE statement. It assigns the remaining data for those truncated columns to the host variables that are referenced in the statement or pointed to by the descriptor. The data that is returned for previously-truncated result values begins at the point of truncation. This form of the CURRENT clause must only be used after a single-row FETCH WITH CONTINUE or FETCH CURRENT CONTINUE statement that has returned partial data for one or more LOB or XML columns. The cursor must be open and positioned on a row.

FETCH CURRENT CONTINUE must pass host variables entries for all columns in the SELECT list, even though the non-LOB columns or non-XML columns will not return any data.

ABSOLUTE

host-variable or *integer-constant* is assigned to an integral value *k*. If a *host-variable* is specified, it must be an exact numeric type with zero scale and must not include an indicator variable. The possible data types for the host variable are DECIMAL(*n*,0) or integer. The DECIMAL data type is limited to DECIMAL(18,0). An *integer-constant* can be up to 31 digits, depending on the application language.

If *k*=0, the cursor is positioned before the first row of the result table. Otherwise, ABSOLUTE positions the cursor to row *k* of the result table if *k*>0, or to *k* rows from the bottom of the table if *k*<0. For example, "ABSOLUTE -1" is the same as "LAST".

Data is returned if the specified position is within the rows of the result table, and a target is specified.

If an absolute position is specified that is before the first row or after the last row of the result table, a warning occurs, values are not assigned to host variables, and the cursor is positioned

either before the first row or after the last row. If the resulting cursor position is after the last row for INSENSITIVE and SENSITIVE STATIC scrollable cursors, the number of rows of the result table are returned in the SQLERRD1 and SQLERRD2 fields of the SQLCA. If row k of the result table is a hole, a warning occurs and values are not assigned to host variables.

FETCH ABSOLUTE 0 results in positioning before the first row and a warning is issued. FETCH BEFORE results in positioning before the first row and no warning is issued.

Table 236 on page 1931 lists some synonymous specifications.

Table 236. Synonymous scroll specifications for ABSOLUTE

Specification	Alternative
ABSOLUTE 0 (but with a warning)	BEFORE (without a warning)
ABSOLUTE +1	FIRST
ABSOLUTE -1	LAST
ABSOLUTE $-m$, $0 < m \leq n$	ABSOLUTE $n+1-m$
ABSOLUTE n	LAST
ABSOLUTE $-n$	FIRST
ABSOLUTE x (with a warning)	AFTER (without a warning)
ABSOLUTE $-x$ (with a warning)	BEFORE (without a warning)

Note: Assume: $0 <= m <= n < x$ Where, n is the number of rows in the result table.

RELATIVE

host-variable or *integer-constant* is assigned to an integral value k . If a *host-variable* is specified, it must be an exact numeric type with zero scale and must not include an indicator variable. The possible data types for the host variable are DECIMAL($n,0$) or integer. The DECIMAL data type is limited to DECIMAL(18,0).

If the cursor is positioned before the first row, or after the last row of the result table, the cursor position is determined as follows:

- If n is 0, the cursor position is unchanged, values are not assigned to host variables, and a warning occurs
- If n is positive, and the cursor is positioned before the first row, the cursor is positioned on a rowset starting at row n
- If n is positive, and the cursor is positioned after the last row, a warning occurs
- If n is negative, and the cursor is positioned before the first row, a warning occurs
- If n is negative, and the cursor is positioned after the last row, the cursor is positioned on a rowset starting as row n from the end of the result table

An *integer-constant* can be up to 31 digits, depending on the application language.

Data is returned if the specified position is within the rows of the result table, and a target is specified.

RELATIVE positions the cursor to the row in the result table that is either k rows after the current row if $k > 0$, or ABS(k) rows before the current row if $k < 0$. For example, "RELATIVE -1" is the same as "PRIOR". If $k = 0$, the position of the cursor does not change (that is, "RELATIVE 0" is the same as "CURRENT").

If a relative position is specified that results in positioning before the first row or after the last row, a warning is issued, values are not assigned to host variables, and the cursor is positioned either before the first row or after the last row. If the resulting cursor position is after the last row for INSENSITIVE and SENSITIVE STATIC scrollable cursors, the number of rows of the result table

is returned in the SQLERRD1 and SQLERRD2 fields of the SQLCA. If the cursor is positioned on a hole and RELATIVE 0 is specified or if the target row is a hole, a warning occurs and values are not assigned to host variables.

If the cursor is defined as a rowset cursor, with isolation level UR or a sensitive dynamic scrollable cursor, it is possible that a different row will be returned than the FETCH that established the most recent cursor position. This can occur while fetching a row again when it is determined to not be there anymore. In this case, fetching continues moving forward to get the row data.

If the cursor position is unknown and RELATIVE 0 is specified, an error occurs.

Table 237 on page 1932 lists some synonymous specifications.

Table 237. Synonymous Scroll Specifications for RELATIVE

Specification	Alternative
RELATIVE +1	NEXT
RELATIVE -1	PRIOR
RELATIVE 0	CURRENT
RELATIVE +r (with a warning)	AFTER (without a warning)
RELATIVE -r (with a warning)	BEFORE (without a warning)

Note: *r* has to be large enough to position the cursor beyond either end of the result table.

rowset-positioned

Positioning of the cursor with rowset-positioned fetch orientations NEXT ROWSET, PRIOR ROWSET, CURRENT ROWSET, and ROWSET STARTING AT RELATIVE is done in relation to the current cursor position. Following a successful *rowset-positioned* FETCH statement, the cursor is positioned on a rowset of data. The number of rows in the rowset is determined either explicitly or implicitly. The FOR *n* ROWS clause in the multiple-row-fetch clause is used to explicitly specify the size of the rowset. Positioning is performed relative to the current row or first row of the current rowset, and the cursor is positioned on all rows of the rowset.

A rowset-positioned fetch orientation must not be specified if the current cursor position is not defined to access rowsets. NEXT ROWSET is the only rowset-positioned fetch orientation that can be specified for cursors that are defined as NO SCROLL.

If a row of the rowset reflects a hole, a warning is returned, data values are not assigned to host-variable arrays for that row (that is, the corresponding positions in the target host-variable arrays are untouched), and -3 is returned in all provided indicator variables for that row. If a hole is detected, and at least one indicator variable is not provided, an error occurs.

NEXT ROWSET

Positions the cursor on the next rowset of the result table relative to the current cursor position, and returns data if a target is specified. The next rowset is logically obtained by fetching the row that follows the current rowset and fetching additional rows until the number of rows that is specified implicitly or explicitly in the FOR *n* ROWS clause is obtained or the last row of the result table is reached.

If the cursor is positioned before the first row of the result table, the cursor is positioned on the first rowset.

If the cursor is positioned on the last row or after the last row of the result table, the cursor position is unchanged, values are not assigned to host-variable arrays, and a warning occurs.

If a row of the rowset reflects a hole, the following actions occur:

- A warning is returned.

- Data values are not assigned to the host-variable-arrays for that row (that is, the corresponding positions in the target host-variable-arrays are untouched).
- A value of -3 is returned in all of the indicator variables that are provided for the row.

If a hole is detected and at least one indicator variable is not provided, an error is returned.

If the cursor is not positioned because of a prior error, values are not assigned to the host-variable-array, and an error is returned. If a row of the rowset would be after the last row of the result table, values are not assigned to host-variable-arrays for that row and any subsequent requested rows of the rowset, and a warning is returned.

NEXT ROWSET is the only rowset positioned fetch orientation that can be explicitly be specified for cursors that are defined as NO SCROLL.

PRIOR ROWSET

Positions the cursor on the previous rowset of the result table relative to the current position, and returns data if a target is specified.

The prior rowset is logically obtained by fetching the row that precedes the current rowset and fetching additional rows until the number of rows that is specified implicitly or explicitly in the FOR *n* ROWS clause is obtained or the last row of the result table is reached.

If the cursor is positioned after the last row of the result table, the cursor is positioned on the last rowset.

If the cursor is positioned before the first row or on the first row of the result table, the cursor position is unchanged, values are not assigned to host-variable arrays, and a warning occurs.

If a row would be before the first row of the result table, the cursor is positioned on a partial rowset that consists of only those rows that are prior to the current position of the cursor starting with the first row of the result table, and a warning is returned. Values are not assigned to the host-variable-arrays for the rows in the rowset for which the warning is returned.

Although the rowset is logically obtained by fetching backwards from before the current rowset, the data is returned to the application starting with the first row of the rowset, to the end of the rowset.

If a row of the rowset reflects a hole, the following actions occur:

- A warning is returned.
- Data values are not assigned to the host-variable-arrays for that row (that is, the corresponding positions in the target host-variable-arrays are untouched).
- A value of -3 is returned in all of the indicator variables that are provided for the row.

If a hole is detected and at least one indicator variable is not provided, an error is returned.

If the cursor is not positioned because of a prior error, values are not assigned to the host-variable-array, and an error is returned.

FIRST ROWSET

Positions the cursor on the first rowset of the result table, and returns data if a target is specified.

If a row of the rowset reflects a hole, the following actions occur:

- A warning is returned.
- Data values are not assigned to the host-variable-arrays for that row (that is, the corresponding positions in the target host-variable-arrays are untouched).
- A value of -3 is returned in all of the indicator variables that are provided for the row.

If a hole is detected and at least one indicator variable is not provided, an error is returned.

If the result table contains fewer rows than specified implicitly or explicitly in the FOR *n* ROWS clause, values are not assigned to host-variable-arrays after the last row of the result table, and a warning is returned.

LAST ROWSET

Positions the cursor on the last rowset of the result table and returns data if a target is specified. The last rowset is logically obtained by fetching the last row of the result table and fetching prior rows until the number of rows in the rowset is obtained or the first row of the result table is reached. Although the rowset is logically obtained by fetching backwards from the bottom of the result table, the data is returned to the application starting with the first row of the rowset, to the end of the rowset, which is also the end of the result table.

If a row of the rowset reflects a hole, the following actions occur:

- A warning is returned.
- Data values are not assigned to the host-variable-arrays for that row (that is, the corresponding positions in the target host-variable-arrays are untouched).
- A value of -3 is returned in all of the indicator variables that are provided for the row.

If a hole is detected and at least one indicator variable is not provided, an error is returned.

If the result table contains fewer rows than specified implicitly or explicitly in the FOR *n* ROWS clause, the last rowset is the same as the first rowset, values are not assigned to host-variable-arrays after the last row of the result table, and a warning is returned.

CURRENT ROWSET

If the FOR *n* ROWS clause specifies a number different from the number of rows specified implicitly or explicitly in the FOR *n* ROWS clause on the most recent FETCH statement for this cursor, the cursor is repositioned on the specified number of rows, starting with the first row of the current rowset. If the cursor is positioned before the first row, or after the last row of the result table, the cursor position is unchanged, values are not assigned to host-variable arrays, and a warning occurs. If the FOR *n* ROWS clause is not specified, it is possible that the FETCH statement will position the cursor on a partial rowset when the FETCH CURRENT ROWSET statement is processed. In this case, Db2 attempts to position the cursor on a full rowset starting with the first row of the current rowset. Otherwise, the position of the cursor on the current rowset is unchanged. Data is returned if a target is specified.

With isolation level UR or a sensitive dynamic scrollable cursor, it is possible that different rows will be returned than the FETCH that established the most recent rowset cursor position. This can occur while refetching the first row of the rowset when it is determined to not be there anymore. In this case, fetching continues moving forward to get the first row of data for the rowset. This can also occur when changes have been made to other rows in the current rowset such that they no longer exist or have been logically moved within (or out of) the result table of the cursor.

If the cursor is not positioned because of a prior error, values are not assigned to the host-variable-array, and an error occurs.

If the current rowset contains fewer rows than specified implicitly or explicitly in the FOR *n* ROWS clause, values are not assigned to host-variable-arrays after the last row, and a warning is returned.

ROWSET STARTING AT ABSOLUTE or RELATIVE *host-variable* or *integer-constant*

Positions the cursor on the rowset beginning at the row of the result table that is indicated by the ABSOLUTE or RELATIVE specification, and returns data if a target is specified.

host-variable or *integer-constant* is assigned to an integral value *k*. If *host-variable* is specified, it must be an exact numeric type with scale zero, and must not include an indicator variable. The possible data types for the host variable are DECIMAL(*n*,0) or integer, where the DECIMAL data type is limited to DECIMAL(18,0). If a constant is specified, the value must be an integer.

If a row of the result table would be after the last row or before the first row of the result table, values are not assigned to host-variable-arrays for that row and a warning is returned.

ABSOLUTE

If *k*=0, an error occurs. If *k*>0, the first row of the rowset is row *k*. If *k*<0, the rowset is positioned on the ABS(*k*) rows from the bottom of the result table. Assume that ABS(*k*) is

equal to the number of rows for the rowset and that there are enough row to return a complete rowset:

- FETCH ROWSET STARTING AT ABSOLUTE -k is the same as FETCH LAST ROWSET.
- FETCH ROWSET STARTING AT ABSOLUTE 1 is the same as FETCH FIRST ROWSET.

RELATIVE

If $k=0$ and the FOR n ROWS clause does not specify a number different from the number most recently specified implicitly or explicitly for this cursor, then the position of the cursor does not change (that is, "RELATIVE ROWSET 0" is the same as "CURRENT ROWSET"). If $k=0$ and the FOR n ROWS clause specifies a number different from the number most recently specified implicitly or explicitly for this cursor, then the cursor is repositioned on the specified number of rows, starting with the first row of the current rowset.

If the cursor is positioned before the first row, or after the last row of the result table, the cursor position is determined as follows:

- If n is 0, the cursor position is unchanged, values are not assigned to host variables, and a warning occurs. This is the same as FETCH CURRENT ROWSET.
- If n is positive, and the cursor is positioned before the first row, the cursor is positioned on a rowset starting a row n .
- If n is positive, and the cursor is positioned after the last row, a warning occurs.
- If n is negative, and the cursor is positioned before the first row, a warning occurs.
- If n is negative, and the cursor is positioned after the last row, the cursor is positioned on a rowset starting at row n from the bottom of the result table.

Otherwise, RELATIVE repositions the cursor so that the first row of the new rowset cursor position is on the row in the result table that is either k rows after the first row of the current rowset cursor position if $k>0$, or $ABS(k)$ rows before the first row of the current rowset cursor position if $k<0$. Assume that $ABS(k)$ is equal to the number of rows for the resulting rowset

- FETCH ROWSET STARTING AT RELATIVE -k is the same as FETCH PRIOR ROWSET.
- FETCH ROWSET STARTING AT RELATIVE k is the same as FETCH NEXT ROWSET.
- FETCH ROWSET STARTING AT RELATIVE 0 is the same as FETCH CURRENT ROWSET.

When ROWSET STARTING AT RELATIVE -n is specified and there are not enough rows between the current position of the cursor and the beginning of the result table to return a complete rowset:

- A warning is returned.
- Values are not assigned to the host-variable-arrays.
- The cursor is positioned before the first row.

If a row of the rowset reflects a hole, If a row of the rowset reflects a hole, the following actions occur:

- A warning is returned.
- Data values are not assigned to the host-variable-arrays for that row (that is, the corresponding positions in the target host-variable-arrays are untouched).
- A value of -3 is returned in all of the indicator variables that are provided for the row.

If a hole is detected and at least one indicator variable is not provided, an error is returned. If a row of the rowset is unknown, values are not assigned to host-variable arrays for that row, and an error is returned. If a row of the rowset would be after the last row or before the first row of the result table, values are not assigned to host-variable-arrays for that row, and a warning is returned.

cursor-name

Identifies the cursor to be used in the fetch operation. The cursor name must identify a declared cursor, as explained in the description of the DECLARE CURSOR statement in [“DECLARE CURSOR](#)

statement” on page 1819, or an allocated cursor, as explained in “[ALLOCATE CURSOR statement](#)” on page 1093. When the FETCH statement is executed, the cursor must be in the open state.

If a single-row-fetch or multiple-row-fetch clause is not specified, the cursor position is adjusted as specified, but no data is returned to the user.

single-row-fetch

When *single-row-fetch* is specified, SENSITIVE or INSENSITIVE can be specified though there is a default. The default depends on the sensitivity of the cursor. If the sensitivity of the cursor is INSENSITIVE, then the default is INSENSITIVE. If the effective sensitivity of the cursor is SENSITIVE DYNAMIC or SENSITIVE STATIC, then the default is SENSITIVE. The single-row-fetch or multiple-row-fetch clause must not be specified when the FETCH BEFORE or FETCH AFTER option is specified. They are required when FETCH BEFORE or FETCH AFTER is not specified. If an individual fetch operation causes the cursor to be positioned or to remain positioned on a row if there is a target specification, the values of the result table are assigned to host variables as specified by the single-fetch-clause.

INTO target-variable or array-variable[array-index]

Identifies one or more targets for the assignment of output values. The number of targets in the INTO clause must equal the number of values that are to be assigned. The first value in the result row is assigned to the first target in the list, the second value to the second target, and so on. A target variable must not be specified more than once in the INTO clause. Each assignment to a target is made in sequence through the list according to the rules described in “[Assignment and comparison](#)” on page 143.

The value 'W' is assigned to the SQLWARN3 field of the SQLCA if the number of targets is less than the number of result column values.

If an error occurs on any assignment, the value is not assigned to the target, and no more values are assigned to the specified targets. Any values that have already been assigned remain assigned.

global-variable-name

Identifies the global variable that is the assignment target. A global variable must only be specified in an SQL PL context. When a global variable is specified as the assignment target, the cursor must be non-scrollable.

host-variable-name

Identifies the host variable that is the assignment target. For LOB output values, the target can be a regular host variable (if it is large enough), a LOB locator variable, or a LOB file reference variable.

SQL-parameter-name

Identifies the parameter that is the assignment target.

SQL-variable-name

Identifies the SQL variable that is the assignment target. SQL variables must be declared before they are used.

array-variable [array-index]

Specifies an array element that is the target of the assignment.

array-variable

Specifies an array variable.

[array-index]

An expression that specifies which element in the array is the target of the assignment.

For an ordinary array, the array index expression must be castable to INTEGER, and must not be the null value. The index value must be between 1 and the maximum cardinality that is defined for the array.

For an associative array, the array index expression must be castable to the index data type of the associative array, and must not be the null value.

array-index must not be:

- An expression that references the CURRENT DATE, CURRENT TIME, or CURRENT TIMESTAMP special register
- A nondeterministic function
- A function that is defined with EXTERNAL ACTION
- A function that is defined with MODIFIES SQL DATA
- A sequence expression

transition-variable-name

Identifies the column that is to be updated in the transition table. A *transition-variable-name* must identify a column in the subject table of a trigger, optionally qualified by a correlation name that identifies the new value.

INTO DESCRIPTOR *descriptor-name*

Identifies an SQLDA that contains a valid description of the host output variables. Result values from the associated SELECT statement are returned to the application program in the output host variables.

Before the FETCH statement is processed, you must set the following fields in the SQLDA:

- SQLN to indicate the number of SQLVAR occurrences provided in the SQLDA
A REXX SQLDA does not contain this field.
- SQLABC to indicate the number of bytes of storage allocated in the SQLDA
- SQLD to indicate the number of variables used in the SQLDA when processing the statement
- SQLVAR occurrences to indicate the attributes of the variables

The SQLDA must have enough storage to contain all SQLVAR occurrences. Each SQLVAR occurrence describes a host variable or buffer into which a value in the result table is to be assigned. If LOBs are present in the results, there must be additional SQLVAR entries for each column of the result table. If the result table contains only base types and distinct types, multiple SQLVAR entries are not needed for each column. However, extra SQLVAR entries are needed for distinct types as well as for LOBs in DESCRIBE and PREPARE INTO statements. For more information on the SQLDA, which includes a description of the SQLVAR and an explanation on how to determine the number of SQLVAR occurrences, see [Appendix G, “SQL descriptor area \(SQLDA\),” on page 2313](#).

SQLD must be set to a value greater than or equal to zero and less than or equal to SQLN.

See [“Identifying an SQLDA in C or C++” on page 2329](#) for how to represent *descriptor-name* in C.

multiple-row-fetch

Retrieves multiple rows of data from the result table of a query. The FOR *n* ROWS clause of the FETCH statement controls how many rows are returned on a single FETCH statement. The fetch orientation determines whether the resulting cursor position (for example, on a single row, rowset, before, or after the result table). Fetching stops when an error is returned, all requested rows are fetched, or the end of data condition is reached.

Fetching multiple rows of data can be done with scrollable or non-scrollable cursors. The operations used to define, open, and close a cursor used for fetching multiple rows of data are the same as for those used for single row FETCH statements.

If the BEFORE or AFTER option is specified, neither single-row-fetch or multiple-row-fetch can be specified.

FOR *host-variable* or *integer-constant* ROWS

host-variable or *integer-constant* is assigned to an integral value *k*. If a host variable is specified, it must be an exact numeric type with a scale of zero and must not include an indicator variable. Furthermore, *k* must be in the range, $0 < k \leq 32767$.

This clause must not be specified if a row-positioned fetch-orientation clause was specified. This clause must also not be specified for a cursor that is defined without rowset access.

If a rowset fetch orientation is specified and this clause is not specified, the number of rows in the resulting rowset is determined as follows:

- If the most recent FETCH statement for this cursor was a rowset-positioned FETCH, the number of rows of the rowset is implicitly determined by the number of rows that was most recently specified (implicitly or explicitly) for this cursor.
- When the most recent FETCH statement for this cursor was either FETCH BEFORE or FETCH AFTER and the most recent FETCH statement for this cursor prior to that was a rowset-positioned FETCH, the number of rows of the rowset is implicitly determined by the number of rows that were most recently specified (implicitly or explicitly) for this cursor.
- Otherwise, the rowset consists of a single row.

For result set cursors, the number of rows for a rowset cursor position, established in the procedure that defined the rowset, is not inherited by the caller when the rowset is returned. Use the FOR *n* ROWS clause on the first rowset FETCH statement for the result set in the calling program to establish the number of rows for the cursor. Otherwise, the rowset consists of a single row.

The cursor is positioned on the row or rowset that is specified by the orientation clause (for example, NEXT ROWSET), and those rows are fetched if a target is specified. After the cursor is positioned on the first row being fetched, the next *k*-1 rows are fetched. Fetching moves forward from the cursor position in the result table and continues until the end of data condition is returned, *k*-1 rows have been fetched, or an assignment error is returned.

The resulting cursor position depends on the fetch orientation that is specified:

- For a row-positioned fetch orientation, the cursor is positioned at the last row successfully retrieved.
- For a rowset-positioned fetch orientation, the cursor is positioned on all the rows retrieved.

The values from each individual fetch are placed in data areas that are described in the INTO or USING clause. If a target specification is provided for a rowset-positioned FETCH, the host-variable arrays must be specified as the target specification, and the arrays must be defined with a dimension of 1 or greater. The target specification must be defined as an array for a rowset-positioned FETCH even if the number of rows that is specified implicitly or explicitly is one. See [Diagnostics information for rowset positioned FETCH statements](#).

INTO *host-variable-array*

Identifies for each column of the result table a host-variable-array to receive the data that is retrieved with this FETCH statement. If the number of host-variable-arrays is less than the number of columns of the result table, the SQLWARN3 field of the SQLCA is set to 'W'. No warning is given if there are more host-variable-arrays than the number of columns in the result table.

Each host-variable-array must be defined in the application program in accordance with the rules for declaring an array. A host-variable-array is used to return the values for a column of the result table. The number of rows to be fetched must be less than or equal to the dimension of each of the host-variable-arrays.

An optional indicator array can be specified for a host-variable-array. It should be specified if the SQLTYPE of any SQLVAR occurrence indicates that the column of the result table is nullable. Additionally, if an operation may result in null values, such as an UPDATE operation that results in a hole, is performed in the application, an indicator array should be specified. Otherwise an error occurs if null values are encountered. The indicators are returned as small integers.

host-variable-array is supported in C/C++, COBOL, and PL/I. For more information, see [“Host-variable arrays in PL/I, C, C++, and COBOL” on page 236](#).

INTO DESCRIPTOR *descriptor-name*

Identifies an SQLDA that must contain a valid description of zero or more host-variable-arrays or buffers into which the values for a column of the result table are to be returned.

Before the FETCH statement is processed, you must set the following fields in the SQLDA:

- SQLN to indicate the number of SQLVAR occurrences provided in the SQLDA.
- SQLABC to indicate the number of bytes of storage allocated for the SQLDA.
- SQLD to indicate the number of variables used in the SQLDA when processing the statement.
- SQLVAR occurrences to indicate the attributes of an element of the host-variable-array. Within each SQLVAR representing an array:
 - SQLTYPE indicates the data type of the elements of the host-variable-array.
 - SQLDATA field points to the first element of the host-variable-array.
 - The length fields (SQLLEN and SQLLONGLEN) are set to indicate the maximum length of a single element of the array.
 - SQLNAME - The length of SQLNAME must be set to 8, and the first two bytes of the data portion of SQLNAME must be initialized to X'0000'. The fifth and sixth bytes must contain a flag field and the seventh and eighth bytes must be initialized to a binary small integer (half word) representation of the dimension of the host-variable-array, and the corresponding indicator array, if one is specified.

The SQLVAR entry for the number of rows must also contain a flag value. The number of rows to be fetched must be less than or equal to the dimension of each of the host-variable arrays.

You set the SQLDATA and SQLIND pointers to the beginning of the corresponding arrays. The SQLDA must have enough storage to contain all SQLVAR occurrences. Each SQLVAR occurrence describes a host-variable-array or buffer into which the values for a column in the result table are to be returned. If any column of the result table is a LOB, two SQLVAR entries must be provided for each SQLVAR, and SQLN must be set to two times the number of SQLVARS. SQLD must be set to a value greater than or equal to zero and less than or equal to SQLN.

Notes for FETCH

Assignment to targets:

The *n*th target identified by the INTO clause or described in the SQLDA corresponds to the *n*th column of the result table of the cursor. The data type of target must be compatible with its corresponding value. If the value is numeric, the target must have the capacity to represent the whole part of the value. For a datetime value, the target must be a character string variable of a minimum length as defined in [“String representations of datetime values” on page 120](#). When the target is a host variable, if the value is null, an indicator variable must be specified.

Assignments are made in sequence through the list. Each assignment to a target is made according to the rules described in [Chapter 2, “Language elements in SQL,” on page 75](#). If the number of targets is less than the number of values in the row, the SQLWARN3 field of the SQLCA is set to 'W'. There is no warning if there are more targets than the number of result columns. If the target is a host variable and the value is null, an indicator variable must be provided. If an assignment error occurs, the value is not assigned to the target and no more values are assigned to targets. Any values that have already been assigned to targets remain assigned.

If more than one assignment is included in the same assignment statement, all expressions are evaluated before the assignments are performed. For example, a reference to a variable in an expression always uses the value of the variable prior to any assignment in the assignment statement.

Normally, you use LOB locators to assign and retrieve data from LOB columns. However, because of compatibility rules, you can also use LOB locators to assign data to targets with other data types. For more information on using locators, see [Saving storage when manipulating LOBs by using LOB locators \(Db2 Application programming and SQL\)](#).

A timestamp without time zone value must not be assigned to a timestamp with time zone target.

The default encoding scheme for the data is the value in the bind option ENCODING, which is the option for application encoding. If this statement is used with functions such as LENGTH or SUBSTRING that are operating on LOB locators, and the LOB data that is specified by the locator is in a different encoding scheme from the ENCODING bind option, LOB materialization and character

conversion occur. To avoid LOB materialization and character conversion, select the LOB data from the SYSIBM.SYSDUMMYA, SYSIBM.SYSDUMMYE, or SYSIBM.SYSDUMMYU sample table.

Restrictions on using the WITH CONTINUE and CURRENT CONTINUE clauses:

When using the WITH CONTINUE clause, the Db2 system will only reserve truncated data for result set columns of the BLOB, CLOB, DBCLOB, or XML data type, and only when the output host variable data type is the appropriate LOB data type.

If an application uses FETCH WITH CONTINUE, and truncated data remains after the FETCH operation, the application cannot perform any intervening operation on that cursor before performing the FETCH CURRENT CONTINUE. If intervening operations on that cursor are performed, the truncated data is lost.

FETCH CURRENT CONTINUE is not supported with multi-row fetch. Also, FETCH CURRENT CONTINUE is not supported for non-LOB and non-XML columns that have been truncated. If truncation occurs for these non-LOB and non-XML columns, the truncated data will be discarded as usual.

Result column evaluation considerations:

If an error occurs as the result of an arithmetic expression in the SELECT list of an outer SELECT statement (division by zero, or overflow) or a numeric conversion error occurs, the result is the null value. As in any other case of a null value, an indicator variable must be provided and the main variable is unchanged. In this case, however, the indicator variable is set to -2. Processing of the statement continues as if the error had not occurred. (However, this error causes a positive SQLCODE.) If you do not provide an indicator variable, a negative value is returned in the SQLCODE field of the SQLCA. Processing of the statement terminates when the error is encountered. No value is assigned to the host variable or to later variables, though any values that have already been assigned to variables remain assigned.

If the specified host variable is not large enough to contain the result, a warning is returned and W is assigned to SQLWARN1 in the SQLCA. The actual length of the result is returned in the indicator variable associated with the host-variable, if an indicator is provided. It is possible that a warning may not be returned on a FETCH operation. This occurs as a result of optimizations, such as the use of system temporary tables or blocking. It is also possible that the returned warning applies to a previously fetched row. When a datetime value is returned, the length of the variable must be large enough to store the complete value. Otherwise, a warning or an error is returned.

Considerations when using the FETCH statement for a rowset cursor that was passed to an accelerator server for processing:

Db2 provides limited support for rowset queries that are passed to an accelerator server for processing. Db2 supports only high performance access to accelerated query data. The data is pre-fetched in rowsets and returned by using *multiple-row-fetch* statements, returning multiple rows of data in one FETCH statement. The following restrictions apply to FETCH statements that are executed against a rowset cursor that was accelerated:

- All FETCH requests must be rowset fetches.
- All FETCH requests must specify a FOR *n* ROWS clause.
- All FETCH requests must specify the same rowset size.
- All FETCH requests must specify target host variables. (The FETCH operation must have a target for positioning.)

Cursor positioning:

An open cursor has three possible positions:

- Before a row
- On a row or rowset
- After the last row

When a scrollable or non-scrollable cursor is opened, it is positioned before the first row in the result table. If a cursor is on a row, that row is called the current row of the cursor. If a cursor is on a rowset, the rows are called the current rowset of the cursor.

A cursor referred to in an UPDATE or DELETE statement must be positioned on a row or rowset. A cursor can only be on a row or rowset as a result of a FETCH statement.

If the cursor was declared SENSITIVE STATIC SCROLL, a row may be a *hole*, from which no values may be fetched, updated, or deleted. Holes do not exist with sensitive dynamic cursors because there is no temporary result table. For more information, see [Holes in the result table of a scrollable cursor \(Db2 Application programming and SQL\)](#).

For scrollable cursors, the cursor position after an error varies depending on the type of error:

- When an operation is attempted against an update or delete hole, or when an update or delete hole is detected, the cursor is positioned on the hole.
- When a FETCH operation is attempted past the end of file, the cursor is positioned after the last row.
- When a FETCH operation is attempted before the beginning of file, the cursor is positioned before the first row.
- When an error causes the cursor position to be invalid such as when a single row positioned update or positioned delete error occurs that causes a rollback, the cursor is closed.

Cursor position after exception condition:

If an error occurs during the execution of a fetch operation, the position of the cursor and the result of any later fetch is unpredictable. It is possible for an error to occur that makes the position of the cursor invalid, in which case the cursor is closed.

If an individual fetch operation specifies a destination that is outside the range of the cursor, a warning is issued (except for FETCH BEFORE or FETCH AFTER), the cursor is positioned before or after the result table, and values are not assigned to host variables.

Concurrency and scrollability:

The current row of a cursor cannot be updated or deleted by another application process if it is locked. Unless it is already locked because it was inserted or updated by the application process during the current unit of work, the current row of a cursor is not locked if:

- The isolation level is UR, or
- The isolation level is CS, and
 - The result table of the cursor is read-only
 - The bind option CURRENTDATA(NO) is in effect

A dynamic scrollable cursor is useful when it is more important to the application to see updated rows and newly inserted rows and there is no need to see deleted rows. The isolation level of CS should be used for maximum concurrency with dynamic scrollable cursors. Specifying an isolation level of RR or RS severely restricts the update of the table, thus defeating the purpose of a SENSITIVE DYNAMIC scrollable cursor. If the application needs a constant result table, a SENSITIVE STATIC scrollable cursor with an isolation level of CS should be used.

Sensitivity of SENSITIVE STATIC SCROLL cursors to database changes:

When SENSITIVE STATIC SCROLL has been declared, the following rules apply:

- For the result of an update operation to be visible within a cursor after "open," the update operation must be a positioned update executed against the cursor, or a FETCH SENSITIVE in a STATIC cursor must be executed against a row which has been updated by some other means (that is, a searched update, committed updates of others, or an update with another cursor in the same process).
- Another process can update the base table of the SELECT statement so that the current values no longer satisfy the WHERE clause. In this case, an "update hole" effectively exists during the time the values in the base table do not satisfy the WHERE clause, and the row is no longer accessible through the cursor. When an attempt is made to fetch a row that has been identified as an update hole, no values are returned, and a warning is issued.

Under SENSITIVE STATIC SCROLL cursors, update holes are only identified during positioned update, positioned delete, and FETCH SENSITIVE operations. Each positioned update, positioned delete, and FETCH SENSITIVE operation does the necessary tests to determine if an update hole exists.

- For the result of a delete operation to be visible within a SENSITIVE STATIC SCROLL cursor, the delete operation must be a positioned delete executed against the cursor or a FETCH SENSITIVE in a STATIC cursor must be executed against a row that has been deleted by some other means (that is, a searched delete, committed deletes of others, or a delete with another cursor in the same process).
- Another process, or the even the same process, may delete a row in the base table of the SELECT statement so that a row of the cursor no longer has a corresponding row in the base table. In this case, a "delete hole" effectively exists, and that row is no longer accessible through the cursor. When an attempt is made to fetch a row that has been identified as a delete hole, no values are returned, and a warning is issued.

Under SENSITIVE STATIC SCROLL cursors, delete holes are identified during positioned update, positioned delete, and FETCH SENSITIVE operations.

- Inserts into the base table or tables of SENSITIVE STATIC SCROLL cursors are not seen after the cursor is opened.

LOB locators:

When information is retrieved into LOB locators and it is not necessary to retain the locator across FETCH statements, it is a good practice to issue a FREE LOCATOR statement before issuing another FETCH statement because locator resources are limited.

Isolation level considerations:

The isolation level of the statement (specified implicitly or explicitly) can affect the result of a rowset-positioned FETCH statement. This is possible when changes are made to the tables underlying the cursor when isolation level UR is used with a dynamic scrollable cursor, or with other isolation levels when rows have been added by the application fetching from the cursor. These situations can occur with the following fetch orientations:

PRIOR ROWSET

With a dynamic scrollable cursor and isolation level UR, the content of a prior rowset can be affected by other activity within the table. It is possible that a row that previously qualified for the cursor, and was included as a member of the "prior" rowset, has since been deleted or modified before it is actually returned as part of the rowset for the current statement. To avoid this behavior, use an isolation level other than UR.

CURRENT ROWSET

With a dynamic scrollable cursor, additional rows can be added between rows that form the rowset that was returned to the user. With isolation level RR, these rows can only be added by the application fetching from the cursor. For isolation levels other than RR, other applications can insert rows that can affect the results of a subsequent FETCH CURRENT ROWSET. To avoid this behavior, use a static scrollable cursor instead of a dynamic scrollable cursor.

LAST ROWSET

With a dynamic scrollable cursor and isolation level UR, the content of the last rowset can be affected by other activity within the table. It is possible that a row that previously qualified for the cursor, and was included as a member of the "last" rowset, has since been deleted or modified before it is actually returned as part of the rowset for the current statement. To avoid this behavior, use an isolation level other than UR.

ROWSET STARTING AT RELATIVE -n (where -n is a negative number)

With a dynamic scrollable cursor and isolation level UR, the content of a prior rowset can be affected by other activity within the table. It is possible that a row that previously qualified for the cursor, and was included as a member of the "prior" rowset, has since been deleted or modified before it is actually returned as part of the rowset for the current statement. To avoid this behavior, use an isolation level other than UR.

Row positioned and rowset positioned FETCH statement interaction:

The following table demonstrates the interaction between row positioned and rowset positioned FETCH statements. The table is based on the following assumptions:

- TABLE T1 has 15 rows
- CURSOR CS1 is declared as follows:

```
DECLARE CS1 SCROLL CURSOR WITH ROWSET POSITIONING FOR
SELECT * FROM T1;
```

- An OPEN CURSOR statement has been successfully executed for CURSOR CS1 and the FETCH statements in the table are executed in the order that they appear in the table.

Table 238. Interaction between row positioned and rowset positioned FETCH statements

FETCH Statement	Cursor Position
FETCH FIRST	Cursor is positioned on row 1.
FETCH FIRST ROWSET	Cursor is positioned on a rowset of size 1, consisting of row 1.
FETCH FIRST ROWSET FOR 5 ROWS	Cursor is positioned on a rowset of size 5, consisting of rows 1, 2, 3, 4, and 5.
FETCH CURRENT ROWSET	Cursor is positioned on a rowset of size 5, consisting of rows 1, 2, 3, 4, and 5.
FETCH CURRENT	Cursor is positioned on row 1
FETCH FIRST ROWSET FOR 5 ROWS	Cursor is positioned on a rowset of size 5, consisting of rows 1, 2, 3, 4, and 5.
FETCH or FETCH NEXT	Cursor is positioned on row 2.
FETCH NEXT ROWSET	Cursor is positioned on a rowset of size 1, consisting of row 3.
FETCH NEXT ROWSET FOR 3 ROWS	Cursor is positioned on a rowset of size 3, consisting of rows 4,5, and 6.
FETCH NEXT ROWSET	Cursor is positioned on a rowset of size 3, consisting of rows 7,8, and 9.
FETCH LAST	Cursor is positioned on row 15.
FETCH LAST ROWSET FOR 2 ROWS	Cursor is positioned on a rowset of size 2, consisting of rows 14 and 15.
FETCH PRIOR ROWSET	Cursor is positioned on a rowset of size 2, consisting of rows 12 and 13.
FETCH ABSOLUTE 2	Cursor is positioned on row 2.
FETCH ROWSET STARTING AT ABSOLUTE 2 FOR 3 ROWS	Cursor is positioned on a rowset of size 3, consisting of rows 2, 3, and 4.
FETCH RELATIVE 2	Cursor is positioned on row 4.
FETCH ROWSET STARTING AT ABSOLUTE 2 FOR 4 ROWS	Cursor is positioned on a rowset of size 4, consisting of rows 2, 3, 4, and 5.
FETCH RELATIVE -1	Cursor is positioned on row 1.
FETCH ROWSET STARTING AT ABSOLUTE 3 FOR 2 ROWS	Cursor is positioned on a rowset of size 2, consisting of rows 3 and 4.
FETCH ROWSET STARTING AT RELATIVE 4	Cursor is positioned on a rowset of size 2, consisting of rows 7 and 8.
FETCH PRIOR	Cursor is positioned on row 6.
FETCH ROWSET STARTING AT ABSOLUTE 13 FOR 5 ROWS	Cursor is positioned on a rowset of size 3, consisting of rows 13, 14, and 15.

Table 238. Interaction between row positioned and rowset positioned FETCH statements (continued)

FETCH Statement	Cursor Position
FETCH FIRST ROWSET	Cursor is positioned on a rowset of size 5, consisting of rows 1, 2, 3, 4, and 5. Note: Even though the previous FETCH statement returned only 3 rows because EOF was encountered, Db2 will remember that 5 rows were requested by the previous FETCH statement.

Considerations for using the FOR n ROWS clause with the FETCH FIRST n ROWS ONLY clause:

A clause specifying the number of rows that you want can be specified in the SELECT statement of a cursor, the FETCH statement for a cursor, or both. However, these clauses have different effects:

- In the SELECT statement, a FETCH FIRST *n* ROWS ONLY clause controls the maximum number of rows that can be accessed with the cursor. When a FETCH statement attempts to retrieve a row beyond the number specified in the FETCH FIRST *n* ROWS ONLY clause of the SELECT statement, an end-of-data condition occurs.
- In a FETCH statement, a FOR *n* ROWS clause controls the number of rows that are returned for a single FETCH statement.

Both of these clauses can be specified.

Referencing columns that will be updated:

If a cursor uses FETCH statements to retrieve columns that will be updated later, specify FOR UPDATE OF when you select the columns. Then specify WHERE CURRENT OF in the subsequent UPDATE or DELETE statements. These clauses prevent Db2 from selecting access through an index on the columns that are being updated, which might otherwise cause Db2 to read the same row more than once.

For more information, see [Updating previously retrieved data \(Db2 Application programming and SQL\)](#).

Diagnostics information for rowset positioned FETCH statements:

A single FETCH statement from a rowset cursor might encounter zero, one, or more conditions. If the current cursor position is not valid for the fetch orientation, a warning occurs and the statement terminates. If a warning or non-terminating error (such as a bind out error) occurs during the fetch of a row, processing continues. In this case, a summary message is returned for the FETCH statement, and additional information about each fetched row is available with the GET DIAGNOSTICS statement. Use the GET DIAGNOSTICS statement to obtain information about all of the conditions that are encountered for one of these FETCH statements. See [“GET DIAGNOSTICS statement”](#) on page 1949 for more information.

The SQLCA returns some information about errors and warnings that are found while fetching from a rowset cursor. Processing stops when the end of data is encountered, or when a terminating condition occurs. After each FETCH statement from a rowset cursor, information is returned to the program through the SQLCA. The SQLCA is set as follows:

- SQLCODE contains the SQLCODE.
- SQLSTATE contains the SQLSTATE.
- SQLERRD1 and SQLERRD2 contain the number of rows of the result table if the cursor is positioned on the last row of the result table.
- SQLERRD3 contains the actual number of rows returned. If SQLERRD3 is less than the number of rows requested, an error or end-of-data condition occurred.
- SQLWARN flags are set to represent all the warnings that were accumulated while processing the FETCH statement.

Consider the following examples, where 10 rows are fetched with a single FETCH statement.

Example 1

Assume that an error is detected on the 5th row. SQLERRD3 is set to 4 for the 4 returned rows, SQLSTATE is set to 22537, and SQLCODE is set to -354. This information is also available from the GET DIAGNOSTICS statement (the information that is returned is generated from connected server, which may differ across different servers). For example:

```
GET DIAGNOSTICS :num_rows = ROW_COUNT, :num_cond = NUMBER;
-- Results of the statement:
-- num_rows = 4 and num_cond = 1 (1 condition)
```

```
GET DIAGNOSTICS CONDITION 1 :sqlstate = RETURNED_SQLSTATE,
:sqlcode = DB2_RETURNED_SQLCODE, :row_num = DB2_ROW_NUMBER;
-- Results of the statement:
-- sqlstate = 22537, sqlcode = -354, and row_num = 5
```

Example 2

Assume that an end-of-data condition is detected on the 6th row and that the cursor does not have immediate sensitivity to updates. SQLERRD3 is set to 5 for the 5 returned rows, SQLSTATE is set to 02000, and SQLCODE is set to +100. This information is also available from the GET DIAGNOSTICS statement. For example:

```
GET DIAGNOSTICS :num_rows = ROW_COUNT, :num_cond = NUMBER;
-- Results of the statement:
-- num_rows = 5 and num_cond = 1 (1 condition)
```

```
GET DIAGNOSTICS CONDITION 1 :sqlstate = RETURNED_SQLSTATE,
:sqlcode = DB2_RETURNED_SQLCODE, :row_num = DB2_ROW_NUMBER;
-- Results of the statement:
-- sqlstate = 02000, sqlcode = 100, and row_num = 6
```

Example 3

Assume that a bind error condition is detected on the 5th row, the condition is recorded, and processing continues. Also, assume that an end-of-data condition is detected on the 8th row. SQLERRD3 is set to 7 for the 7 returned rows, SQLSTATE is set to 02000, and SQLCODE is set to +100. Processing to complete the FETCH statement is performed, and the bind out error that occurred is noted. An additional SQLCODE is recorded for the bind out error. SQLCODE is set to -354, and SQLSTATE is set to 01668. Use the GET DIAGNOSTICS statement to determine what went on. For example:

```
GET DIAGNOSTICS :num_rows = ROW_COUNT, :num_cond = NUMBER;
-- Results of the statement:
-- num_rows = 7 and num_cond = 3 (3 conditions)
```

```
GET DIAGNOSTICS CONDITION 1 :sqlstate = RETURNED_SQLSTATE,
:sqlcode = RETURNED_SQLCODE, :row_num = DB2_ROW_NUMBER;
-- Results of the statement:
-- sqlstate = 01668, sqlcode = -354, and row_num = 0
```

```
GET DIAGNOSTICS CONDITION 2 :sqlstate = RETURNED_SQLSTATE,
:sqlcode = RETURNED_SQLCODE, :row_num = DB2_ROW_NUMBER;
-- Results of the statement:
-- sqlstate = 02000, sqlcode = 100, and row_num = 0
```

```
GET DIAGNOSTICS CONDITION 3 :sqlstate = RETURNED_SQLSTATE,
:sqlcode = RETURNED_SQLCODE, :row_num = DB2_ROW_NUMBER;
-- Results of the statement:
-- sqlstate = 22003, sqlcode = -302, and row_num = 5
```

In some cases, Db2 returns a warning if indicator variables are provided, or an error if indicator variables are not provided. These errors can be thought of as data mapping errors that result in a warning if indicator variables are provided.

- If indicator variables are provided, Db2 returns all rows to the user, marking the errors in the indicator variables. The SQLCODE and SQLSTATE contain the warning from the last data mapping

error. The GET DIAGNOSTICS statement can be used to retrieve information about all the data mapping errors that have occurred.

- If some or no indicator variables are provided, all rows are returned as above until the first data mapping error that does not have indicator variables is detected. The rows successfully fetched are returned and the SQLSTATE, SQLCODE, and SQLWARN flags are set, if necessary. (The SQLCODE may be 0 or a positive value).

It is possible, if a data mapping error occurs, for the positioning of the cursor to be successful. In this case, the cursor is positioned on the rowset that encountered the data mapping error.

Consider the following examples, which try to fetch 10 rows with a single FETCH statement.

Example 1

Assume that indicators have been provided for values returned for column 1, but not for column 2. The 5th row has a data mapping error (+802) for column 1, and the 7th row has a data mapping error for column 2 (-802 is returned because an indicator was not provided for column 2). SQLERRD3 is set to 6 for the 6 returned rows, SQLSTATE and SQLCODE are set to the error from the 7th row fetched. The indicator variable for the 5th row column 1 indicates that a data mapping error was found. This information is also available from the GET DIAGNOSTICS statement, for example:

```
GET DIAGNOSTICS :num_rows = ROW_COUNT, :num_cond = NUMBER;
-- Results of the statement:
-- num_rows = 6 and num_cond = 2 (2 conditions)
```

```
GET DIAGNOSTICS CONDITION 1 :sqlstate = RETURNED_SQLSTATE,
:sqlcode = DB2_RETURNED_SQLCODE, :row_num = DB2_ROW_NUMBER;
-- Results of the statement:
-- sqlstate = 01519, sqlcode = +802, and row_num = 5
```

```
GET DIAGNOSTICS CONDITION 2 :sqlstate = RETURNED_SQLSTATE,
:sqlcode = DB2_RETURNED_SQLCODE, :row_num = DB2_ROW_NUMBER;
-- Results of the statement:
-- sqlstate = 22003, sqlcode = -802, and row_num = 7
```

The resulting cursor position is unknown.

Example 2

Assume that null indicators are provided, that rows 3 and 5 are holes, and that data exists for the other requested rows. SQLERRD3 is set to 10 to reflect that 10 fetches were completed and that information has been returned for the 10 requested rows. Eight rows actually contain data. For two rows, indicator variables are set to indicate no data was returned for those rows. SQLSTATE is set to 02502, SQLCODE is set to +222, and all null indicators for rows 3 and 5 are set to -3 to indicate that a hole was detected. This information is also available from the GET DIAGNOSTICS statement, for example:

```
GET DIAGNOSTICS :num_rows = ROW_COUNT, :num_cond = NUMBER;
-- Results of the statement:
-- num_rows = 10 and num_cond = 2 (2 conditions)
```

```
GET DIAGNOSTICS CONDITION 1 :sqlstate = RETURNED_SQLSTATE,
:sqlcode = DB2_RETURNED_SQLCODE, :row_num = DB2_ROW_NUMBER;
-- Results of the statement:
-- sqlstate = 02502, sqlcode = +222, and row_num = 3
```

```
GET DIAGNOSTICS CONDITION 2 :sqlstate = RETURNED_SQLSTATE,
:sqlcode = DB2_RETURNED_SQLCODE, :row_num = DB2_ROW_NUMBER;
-- Results of the statement:
-- sqlstate = 02502, sqlcode = +222, and row_num = 5
```

If a null indicator was not provided for any variable in a row that was a hole, an error occurs.

SQLCA usage summary:

For multiple-row-fetch, the fields of the SQLCA are set as follows:

Condition		Action: Resulting Values Stored in the SQLCA Fields		
Errors	Data	SQLSTATE	SQLCODE	SQLERRD3
No ¹	Return all requested rows	00000	0	Number of rows requested
No ¹	Return data for subset of requested rows, end of data	02000	+100	Number of rows
No ¹	Return all requested rows	sqlstate(2)	sqlcode(2)	Number of rows requested
Yes ¹	Return successfully fetched rows	sqlstate(3)	sqlcode(3)	Number of rows
Yes ¹	Return successfully fetched rows	sqlstate(4)	sqlcode(4)	Number of rows

Notes:

1. SQLWARN flags may be set in all cases, even if there are no other warnings or errors indicated. The warning flags are an accumulation of all warning flags set while processing the multiple-row-fetch.
2. sqlcode is the last positive SQLCODE, and sqlstate is the corresponding SQLSTATE value.
3. Database Server detected error. sqlcode is the first negative SQLCODE encountered, sqlstate is the corresponding SQLSTATE value.
4. Client detected error. sqlcode is the first negative SQLCODE encountered, sqlstate is one of the following SQLSTATES: 22002, 22008, 22509, 22518, or 55021.

Providing indicator variables for error conditions:

If an error occurs as the result of an arithmetic expression in the SELECT list of an outer SELECT statement (division by zero or overflow) or a numeric conversion error occurs, the result is the null value. As in any other case of a null value, an indicator variable must be provided and the main variable is unchanged. In this case, however, the indicator variable is set to -2. Processing of the statement continues as if the error had not occurred. (However, this error causes a positive SQLCODE.)

If you do not provide an indicator variable, a negative value is returned in the SQLCODE field of the SQLCA. Processing of the statement terminates when the error is encountered. No value is assigned to the host variable or to later variables, though any values that have already been assigned to variables remain assigned. Additionally, a -3 is returned in all indicators provided by the application when a hole was detected for the row on a rowset positioned FETCH, and values were not returned for the row. Processing of the statement terminates if a hole is detected and at least one indicator variable was not provided by the application.

Alternative syntax and synonyms:

USING DESCRIPTOR can be specified as a synonym for INTO DESCRIPTOR.

Examples for FETCH

Example 1

The FETCH statement fetches the results of the SELECT statement into the application program variables DNUM, DNAME, and MNUM. When no more rows remain to be fetched, the not found condition is returned.

```
EXEC SQL DECLARE C1 CURSOR FOR
  SELECT DEPTNO, DEPTNAME, MGRNO FROM DSN8C10.DEPT
  WHERE ADMRDEPT = 'A00';
EXEC SQL OPEN C1;
DO WHILE (SQLCODE = 0);
  EXEC SQL FETCH C1 INTO :DNUM, :DNAME, :MNUM;
```

```
END;  
EXEC SQL CLOSE C1;
```

Example 2

For an example of FETCH statements with a dynamic scrollable cursor, see [“Example 8” on page 1828](#).

Example 3

Fetch the last 5 rows of the result table C1 using cursor C1:

```
FETCH ROWSET STARTING AT ABSOLUTE -5  
FROM C1 FOR 5 ROWS INTO DESCRIPTOR :MYDESCR;
```

Example 4

Fetch 6 rows starting at row 10 for cursor CURS1, and fetch the data into three host-variable-arrays:

```
FETCH ROWSET STARTING AT ABSOLUTE 10  
FROM CURS1 FOR 6 ROWS  
INTO :hav1, :hva2, :hva3;
```

Alternatively, a descriptor could have been specified in an INTO DESCRIPTOR clause where the information in the SQLDA reflects the data types of the host-variable-arrays:

```
FETCH ROWSET STARTING AT ABSOLUTE 10  
FROM CURS1 FOR 6 ROWS  
INTO DESCRIPTOR :MYDESCR;
```

Example 5

Suppose that the following array type, array variable, and table have been defined.

```
CREATE TYPE INTARRAY AS INTEGER ARRAY[100];  
CREATE TABLE T1 (COL1 CHAR(10), COL2 INT);
```

Use an array variable as an output target for a FETCH statement. The array variable is specified in the INTO clause of the FETCH statement.

```
CREATE PROCEDURE PROCESSINTARRAY (OUT INTOUTARRAY INTARRAY)  
BEGIN  
  DECLARE INTA INTARRAY;  
  DECLARE INTB INTARRAY;  
  DECLARE INTV INTEGER DEFAULT 1;  
  DECLARE STMT CHAR(100);  
  DECLARE C2 CURSOR FOR S1;  
  --  
  -- Initialize the array  
  --  
  SET INTA = ARRAY[1,INTEGER(2),3+0,4,5,6] ;  
  --  
  -- Use dynamic SQL with an array parameter marker and a parameter marker  
  -- containing the index to retrieve the value from the array parameter.  
  -- The array is referenced in a predicate.  
  --  
  SET STMT = 'SELECT COL1 FROM T1 WHERE COL2 = CAST(? AS INTARRAY)[?]';  
  PREPARE S1 FROM STMT;  
  OPEN C2 USING INTA, INTV;  
  FETCH C2 INTO INTB ; -- INTB is an array variable that is used  
                      -- as a target for the fetch statement.  
  CLOSE C2;  
  SET INTOUTARRAY=INTB;  
END
```

FREE LOCATOR statement

The FREE LOCATOR statement removes the association between a LOB locator variable and its value.

Invocation for FREE LOCATOR

This statement can only be embedded in an application program. It cannot be issued interactively. It is an executable statement that can be dynamically prepared. However, the EXECUTE statement with the USING clause must be used to execute the prepared statement. FREE LOCATOR cannot be used with the EXECUTE IMMEDIATE statement. It must not be specified in Java.

Authorization for FREE LOCATOR

None required.

Syntax for FREE LOCATOR

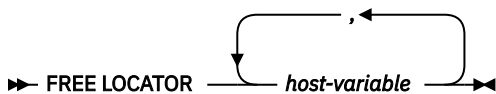

Description for FREE LOCATOR

host-variable, ...

Identifies one or more locator variables that must be declared in accordance with the rules for declaring locator variables. The locator variable type must be a binary large object locator, a character large object locator, or a double-byte character large object locator.

The *host-variable* must currently have a locator assigned to it. That is, a locator must have been assigned during this unit of work (by a FETCH, SELECT INTO, assignment statement, SET *host-variable* statement, or VALUES INTO statement) and must not subsequently have been freed (by a FREE LOCATOR statement); otherwise, an error is returned.

If more than one locator is specified and an error is returned on one of the locators, it is possible that some locators have been freed and others have not been freed.

Example for FREE LOCATOR

Assume that the employee table contains columns RESUME, HISTORY, and PICTURE and that locators have been established in a program to represent the column values. Free the CLOB locator variables LOCRES and LOCHIST, and the BLOB locator variable LOCPIC.

```
EXEC SQL FREE LOCATOR :LOCRES, :LOCHIST, :LOCPIC
```

GET DIAGNOSTICS statement

The GET DIAGNOSTICS statement provides diagnostic information about the last SQL statement (other than a GET DIAGNOSTICS statement) that was executed. This diagnostic information is gathered as the previous SQL statement is executed. Some of the information available through the GET DIAGNOSTICS statement is also available in the SQLCA.

Invocation for GET DIAGNOSTICS

This statement can only be embedded in an application program. It is an executable statement that cannot be dynamically prepared.

Authorization for GET DIAGNOSTICS

None required.

Syntax for GET DIAGNOSTICS

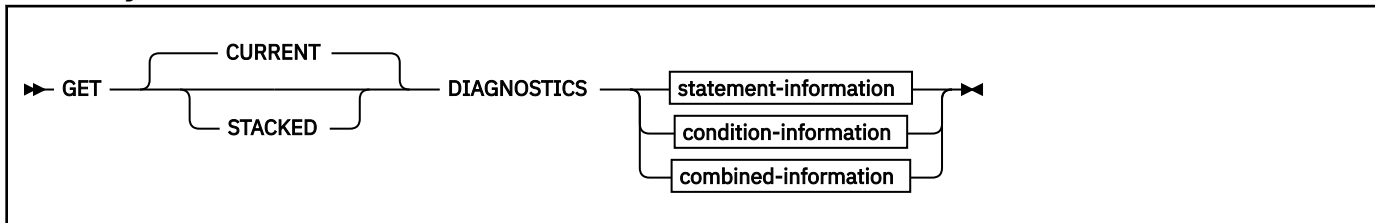

statement-information:

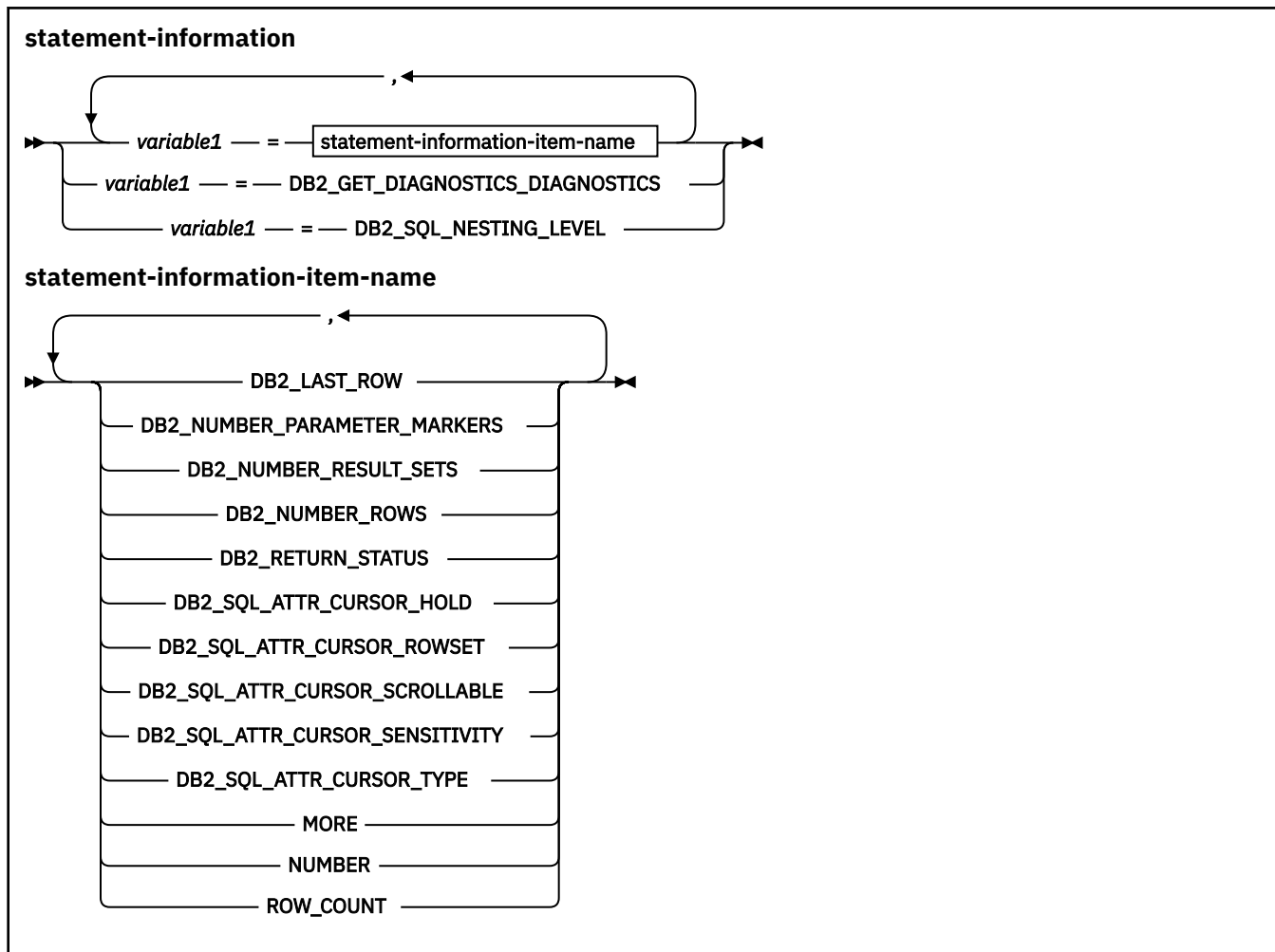

condition-information:

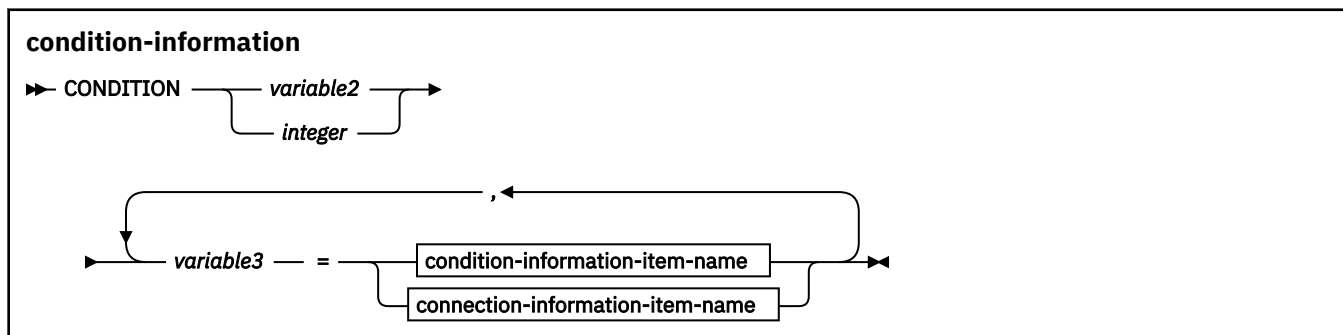

condition-information-item-name

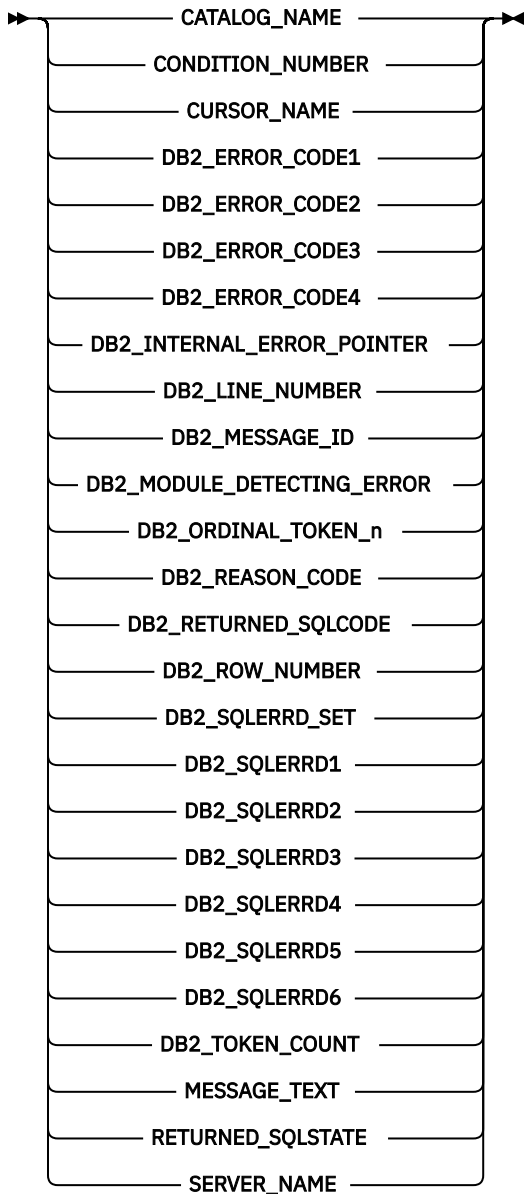

connection-information-item-name

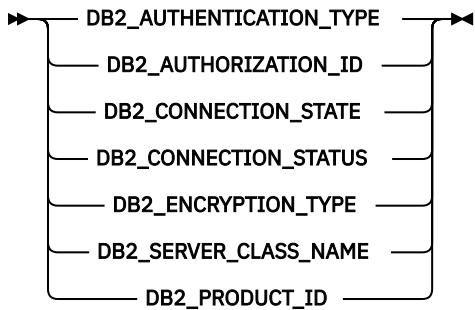

combined-information:

combined-information

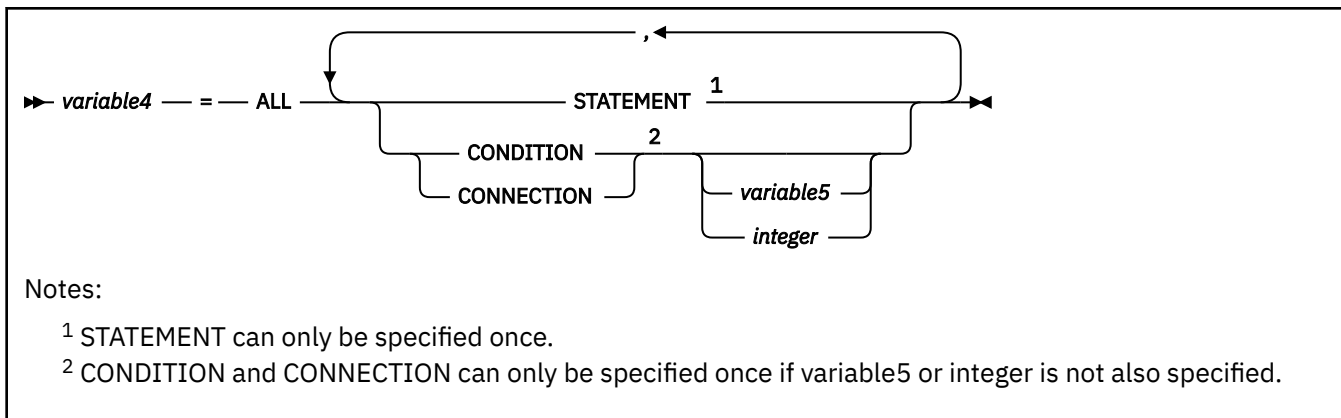

Description for GET DIAGNOSTICS

Diagnostic information is provided in three main areas: statement information, condition information, and combined information. After the execution of an SQL statement, information about the execution of the statement is provided as statement information, and at least one instance of condition information is provided. The number of instances of the condition information is indicated by the NUMBER item that is available in the statement information. Combined information contains a text representation of all the information gathered about the execution of the SQL statement.

The diagnostic information that is provided is specific to the server. If you are connected to a server other than Db2 for z/OS, see that product's documentation for the diagnostic information that is returned.

CURRENT

Specifies that information is to be returned from the first diagnostics area. It corresponds to the previous SQL statement that was executed that was not a GET DIAGNOSTICS or compound statement. CURRENT is the default.

STACKED

Specifies that information is to be returned from the stacked diagnostics area. The stacked diagnostics area is only available within a handler in native SQL procedures, compiled SQL functions, and triggers. The stacked diagnostics area corresponds to the previous SQL statement (that was not a GET DIAGNOSTICS or compound statement) that was executed before the handler was entered. If the GET DIAGNOSTICS statement is the first statement within a handler, the current diagnostics area and the stacked diagnostics area contain the same diagnostics information.

statement-information

Provides information about the last SQL statement executed.

variable1

Identifies a variable described in the program in accordance with the rules for declaring variables. The data type of the variable must be the data type as specified in Data types for GET DIAGNOSTICS items.

The variable is assigned the value of the specified statement information item. If the value is truncated when assigning it to the variable, a warning is returned and the GET_DIAGNOSTICS_DIAGNOSTICS item of the diagnostics area is updated with the details of this condition. If a DIAGNOSTICS item is not set, the variable is set to a default value, based on its data type: 0 for an exact numeric field, an empty string for a VARCHAR field, and blanks for a CHAR field.

DB2_GET_DIAGNOSTICS_DIAGNOSTICS

Contains textual information about errors or warnings that might have occurred in the execution of the GET DIAGNOSTICS statement. The format of the information is similar to what would be returned by a GET DIAGNOSTICS :hv = ALL statement.

DB2_SQL_NESTING_LEVEL

Identifies the current level of nesting or recursion that is in effect when the GET DIAGNOSTICS statement was executed. Each level of nesting corresponds to a nested or recursive invocation of

a compiled SQL function, native SQL procedure, or trigger. If the GET DIAGNOSTICS statement is executed outside of a level of nesting, the value of zero is returned.

statement-information-item-name:

DB2_LAST_ROW

For a multiple-row FETCH statement, contains a value of +100 if the last row currently in the table is in the set of rows that have been fetched. For cursors that are not sensitive to updates, there would be no need to do a subsequent FETCH, because the result would be an end-of-data indication. For cursors that are sensitive to updates, a subsequent FETCH may return more data if a row had been inserted before the FETCH was executed. For statements other than multiple-row FETCH statements, or for multiple-row FETCH statements that do not contain the last row, this variable contains the value 0.

An end of data warning might not occur and DB2_LAST_ROW might not contain +100 when the number of rows returned is equal to the number of rows requested and the last row of data returned is the last row of data.

DB2_NUMBER_PARAMETER_MARKERS

For a PREPARE statement, contains the number of parameter markers in the prepared statement. Otherwise, or if the server only returns an SQLCA, the value zero is returned.

DB2_NUMBER_RESULT_SETS

For a CALL statement, contains the actual number of result sets returned by the procedure. Otherwise, or if the server only returns an SQLCA, the value zero is returned.

DB2_NUMBER_ROWS

If the previous SQL statement was an OPEN or a FETCH that caused the size of the result table to be known, returns the number of rows in the result table. For SENSITIVE DYNAMIC cursors, this value can be thought of as an approximation because rows that are inserted and deleted will affect the next retrieval of this value. If the previous SQL statement was a PREPARE statement, returns the estimated number of rows in the result table for the prepared statement. Otherwise, or if the server only returns an SQLCA, the value zero is returned.

DB2_RETURN_STATUS

Identifies the status value returned from the stored procedure associated with the previously executed SQL statement, provided that the statement was a CALL statement that invoked a procedure that returns a status. Otherwise, or if the server only returns an SQLCA, the value zero is returned.

DB2_SQL_ATTR_CURSOR_HOLD

For an ALLOCATE or OPEN statement, indicates whether a cursor can be held open across multiple units of work.

- N indicates that this cursor does not remain open across multiple units of work.
- Y indicates that this cursor remains open across multiple units of work.

Otherwise, a blank is returned.

DB2_SQL_ATTR_CURSOR_ROWSET

For an ALLOCATE or OPEN statement, indicates whether or not a cursor can be accessed using rowset positioning.

- N indicates that this cursor supports only row positioned operations.
- Y indicates that this cursor supports rowset positioned operations.

Otherwise, a blank is returned.

DB2_SQL_ATTR_CURSOR_SCROLLABLE

For an ALLOCATE or OPEN statement, indicates whether or not a cursor can be scrolled forward and backward.

- N indicates that this cursor is not scrollable.
- Y indicates that this cursor is scrollable.

Otherwise, a blank is returned.

DB2_SQL_ATTR_CURSOR_SENSITIVITY

For an ALLOCATE or OPEN statement, indicates whether or not a cursor does or does not show updates to cursor rows made by other connections.

- I indicates insensitive.
- S indicates sensitive.

Otherwise, a blank is returned.

DB2_SQL_ATTR_CURSOR_TYPE

For an ALLOCATE or OPEN statement, indicates the type of cursor, whether a cursor type is forward-only, static, or dynamic.

- F indicates a forward cursor.
- D indicates a dynamic cursor.
- S indicates a static cursor.

Otherwise, a blank is returned.

MORE

Indicates whether some of the warning and errors from the previous SQL statement were stored or discarded.

- N indicates that all the warnings and errors from the previous SQL statement are stored in the diagnostic area.
- Y indicates that some of the warnings and errors from the previous SQL statement were discarded because the amount of storage needed to record warnings and errors exceeded 65535 bytes.

NUMBER

Returns the number of errors and warnings detected by the execution of the previous SQL statement, other than a GET DIAGNOSTICS statement, that have been stored in the diagnostics area. If the previous SQL statement returned an SQLSTATE of 00000 or no previous SQL statement has been executed, the number returned is one.

The GET DIAGNOSTICS statement itself may return information via the SQLSTATE parameter, but does not modify the previous contents of the diagnostics area, except for the DB2_GET_DIAGNOSTICS_DIAGNOSTICS item.

ROW_COUNT

Identifies the number of rows associated with the previous SQL statement that was executed.

If the previous SQL statement is a DELETE, INSERT, UPDATE, or MERGE statement, ROW_COUNT indicates the number of rows that are qualified to be deleted, inserted, or updated by that statement, excluding rows that are affected by triggers or referential integrity constraints. The count does not include rows that are inserted as a result of processing a FOR PORTION OF clause for in an SQL data change statement.

For the OPEN of a cursor for a SELECT with a data change statement, or a SELECT INTO statement, SQLERRD(3) contains the number of rows affected by the embedded data change statement. The value is 0 if the SQL statement fails, indicating that all changes made in executing the statement canceled.

A value of -1 indicates a mass delete from a table in a segmented table space and the DELETE statement did not include selection criteria, or a truncate operation. If the delete was against a view, then neither the DELETE statement nor the definition of the view included selection criteria.

For a REFRESH TABLE statement, SQLERRD(3) contains the number of rows inserted into the materialized query table.

If the previous SQL statement is a multiple-row FETCH, ROW_COUNT identifies the number of rows fetched.

Otherwise, or if the server only returns an SQLCA, the value zero is returned.

condition-information

Assigns the values of the specified condition information to the associated variables. The variable specified must be of the data type that is compatible with the data type of the specified diagnostic-ID or an error occurs. If the value of the condition is truncated when assigning it to the variable, an error occurs. If an indicator variable was provided, the length of the value is returned in the indicator variable.

If a DIAGNOSTICS item is not set, then the variable is set to a default value, based on the data type of the item. The specific value will be 0 for a numeric field, an empty string for a VARCHAR field, and blanks for a CHAR field.

variable2 or integer

Identifies a variable described in the program in accordance with the rules for declaring variables. The value identifies the diagnostic for which information is requested. Each diagnostic that occurs while executing an SQL statement is assigned an integer. The value 1 indicates the first diagnostic, 2 indicates the second diagnostic, and so on. If the value is 1, the diagnostic information that is retrieved corresponds to the condition that is indicated by the SQLSTATE value actually returned by the execution of the previous SQL statement (other than a GET DIAGNOSTICS statement). The variable specified must be an integer data type, or an error occurs. An indicator variable is not allowed when this is a host variable; an error occurs. If a value is specified that is less than or equal to zero, or greater than the number of available diagnostics, an error occurs.

variable3

Identifies a variable described in the program in accordance with the rules for declaring variables. The data type of the variable must be the data type as specified in [Data types for GET DIAGNOSTICS items](#) for the indicated condition-information item.

condition-information-item-name**CATALOG_NAME**

If the returned SQLSTATE is any one of the following values, the constraint that caused the error is a referential, check, or unique constraint. The location (RDB) name of the server that generated the condition is returned.

- Class 09 (Triggered Action Exception),
- Class 23 (Integrity Constraint Violation)
- Class 27 (Triggered Data Change Violation)
- 40002 (Transaction Rollback - Integrity Constraint Violation)
- 40004 (Transaction Rollback - Triggered Action Exception)

If the returned SQLSTATE is class 42 (Syntax Error or Access Rule Violation), the server name of the table that caused the error is returned.

If the returned SQLSTATE is class 44 (WITH CHECK OPTION Violation), the server name of the view that caused the error is returned.

Otherwise, the empty string is returned.

The actual server name may be different than the server name specified, either implicitly or explicitly, on the CONNECT statement because of the use of aliases or synonyms.

CONDITION_NUMBER

Returns the number of the diagnostic returned.

CURSOR_NAME

If the returned SQLSTATE is class 24 (Invalid Cursor State), the name of the cursor is returned. Otherwise, the empty string is returned.

DB2_ERROR_CODE1

Returns an internal error code. Otherwise, or if the server only returns an SQLCA, the value 0 is returned.

DB2_ERROR_CODE2

Returns an internal error code. Otherwise, or if the server only returns an SQLCA, the value 0 is returned.

DB2_ERROR_CODE3

Returns an internal error code. Otherwise, or if the server only returns an SQLCA, the value 0 is returned.

DB2_ERROR_CODE4

Returns an internal error code. Otherwise, or if the server only returns an SQLCA, the value 0 is returned.

DB2_INTERNAL_ERROR_POINTER

For some errors, this is a negative value that is an internal error pointer. Otherwise, the value 0 is returned.

DB2_LINE_NUMBER

Returns the line number where an error is encountered in parsing a dynamic statement. Also returns the line number where an error is encountered in parsing, binding, or executing a CREATE or ALTER statement for a native SQL procedure, compiled SQL function, or trigger. DB2_LINE_NUMBER also returns the line number when a CALL statement invokes a native SQL procedure and the procedure returns with an error. This information is not returned for an external SQL procedure.

This value will only be meaningful if the statement source contains new line control characters.

DB2_MESSAGE_ID

Corresponds to the message that is contained in the MESSAGE_TEXT diagnostic item (for example, DSNT102I or DSNU180I).

DB2_MODULE_DETECTING_ERROR

Returns an identifier indicating which module detected the error. For a SIGNAL statement that is issued from a routine, the value 'ROUTINE' is returned. Otherwise, the string 'DSN ' is returned.

DB2_ORDINAL_TOKEN_n

Returns the *n*th token. *n* must be a value 1–100. For example, DB2_ORDINAL_TOKEN_1 would return the value of the first token, DB2_ORDINAL_TOKEN_2 the second token, and so on. A numeric value for a token is converted to characters before being returned. If there is no value for the token, or if the server only returns an SQLCA, an empty string is returned.

DB2_REASON_CODE

Contains the reason code for errors that have a reason code token in the message text. Otherwise, the value zero is returned.

DB2_RETURNED_SQLCODE

Returns the SQLCODE for the specified diagnostic.

DB2_ROW_NUMBER

For a statement that involves multiple rows, returns the number of the row where the condition was encountered, when such information is available and applicable. If SQLCODE +1 or +20237 is returned, DB2_ROW_NUMBER returns a value of 0.

DB2_SQLERRD_SET

A value of Y indicates that the DB2_SQLERRD1 through DB2_SQLERRD items might be set. These items are set only when communicating with a server that returns the SQLCA SQL communications area and not the new diagnostics area. Otherwise, a blank is returned.

DB2_SQLERRD1

Returns the value of sqlerrd(1) from the SQLCA that is returned by the server. Otherwise, the value zero is returned.

DB2_SQLERRD2

Returns the value of sqlerrd(2) from the SQLCA that is returned by the server. Otherwise, the value zero is returned.

DB2_SQLERRD3

Returns the value of sqlerrd(3) from the SQLCA that is returned by the server. Otherwise, the value zero is returned.

DB2_SQLERRD4

Returns the value of sqlerrd(4) from the SQLCA that is returned by the server. Otherwise, the value zero is returned.

DB2_SQLERRD5

Returns the value of sqlerrd(5) from the SQLCA that is returned by the server. Otherwise, the value zero is returned.

DB2_SQLERRD6

Returns the value of sqlerrd(6) from the SQLCA that is returned by the server. Otherwise, the value zero is returned.

DB2_TOKEN_COUNT

Returns the number of tokens available for the specified diagnostic ID.

MESSAGE_TEXT

Returns the message text that is associated with the SQLCODE. This is the short text, including substituted tokens. The message text does not contain the message number. When the SQLCODE is 0, the empty string is returned, even if the RETURNED_SQLSTATE value indicates a warning condition.

RETURNED_SQLSTATE

Returns the SQLSTATE for the specified diagnostic.

SERVER_NAME

If the previous SQL statement is a CONNECT, DISCONNECT, or SET CONNECTION statement, returns the name of the server specified in the previous statement is returned. Otherwise, the name of the server where the statement executes is returned.

connection-information-item-name

Provides information about the last SQL statement executed if it was a CONNECT statement.

DB2_AUTHENTICATION_TYPE

Contains an authentication type value of:

- 'S' for a server authentication
- 'C' for client authentication
- 'T' for trusted server authentication
- Otherwise, or if the server only returns an SQLCA, a blank is returned

DB2_AUTHORIZATION_ID

Authorization ID used by connected server. Because of user ID translation and authorization exits, the local user ID may not be the authorized ID used by the server.

DB2_CONNECTION_STATE

Contains the connection state:

- -1 if the connection is unconnected
- 1 if the connection is connected

Otherwise, or if the server only returns an SQLCA, the value zero is returned.

DB2_CONNECTION_STATUS

Contains a value of:

- 1 if committable updates can be performed on the connection for this unit of work
- 2 if no committable updates can be performed on the connection for this unit of work

Otherwise, or if the server only returns an SQLCA, the value zero is returned.

DB2_SERVER_CLASS_NAME

For a CONNECT or SET CONNECTION statement, contains one of the following values:

- QAS for Db2 for i
- QDB2 for Db2 for z/OS
- QDB2/2 for Db2 for OS/2
- QDB2/6000 for Db2 for AIX®
- QDB2/6000 PE for Db2 for AIX Parallel Edition
- QDB2/AIX64 for Db2 for AIX 64-bit
- QDB2/HPUX for Db2 for HP-UX
- QDB2/HP64 for Db2 for HP-UX 64-bit
- QDB2/LINUX for Db2 for Linux, UNIX, and Windows
- QDB2/LINUX390 for Db2 for Linux, UNIX, and Windows
- QDB2/LINUXIA64 for Db2 for Linux, UNIX, and Windows
- QDB2/LINUXPPC for Db2 for Linux, UNIX, and Windows
- QDB2/LINUXPPC64 for Db2 for Linux, UNIX, and Windows
- QDB2/LINUXZ64 for Db2 for Linux, UNIX, and Windows
- QDB2/NT for Db2 for Linux, UNIX, and Windows
- QDB2/NT64 for Db2 for Linux, UNIX, and Windows
- QDB2/PTX for Db2 for NUMA-Q®
- QDB2/SCO for Db2 for SCO UnixWare
- QDB2/SGI for Db2 for Silicon Graphics
- QDB2/SNI for Db2 for Siemens Nixdorf
- QDB2/SUN for Db2 for SUN Solaris
- QDB2/SUN64 for Db2 for SUN Solaris 64-bit
- QDB2/Windows 95 for Db2 for Linux, UNIX, and Windows
- QSQLDS/VM for Db2 server for VSE and VM
- QSQLDS/VSE for Db2 server for VSE and VM

Otherwise, the empty string is returned.

DB2_ENCRYPTION_TYPE

The level of encryption for the connection:

- A indicates only the authentication tokens (authid and password) are encrypted.
- D indicates all data is encrypted for the connection.
- Otherwise, a blank is returned.

DB2_PRODUCT_ID

Returns a product signature. If the application server is an IBM relational database product, the form is *pppvrrm*.

combined-information

Provides a text representation of all the information gathered about the execution of the SQL statement.

ALL

Indicates that all diagnostic items that are set for the last SQL statement executed are to be combined into one string. The format of the string is a semicolon separated list of all of the available diagnostic information in the form: *item-name[(condition-number)]=value-converted-to-character...*; as shown in the following example:

```
NUMBER=1;RETURNED_SQLSTATE=02000;DB2_RETURNED_SQLCODE=+100;
```

variable4

Identifies a variable described in the program in accordance with the rules for declaring variables. The data type of the variable must be VARCHAR. If the length of *variable4* is not sufficient to hold the full returned diagnostic string, the string is truncated, a warning is returned, and the GET_DIAGNOSTICS_DIAGNOSTICS item of the diagnostics area is updated with the details of this condition.

STATEMENT

Indicates that all statement-information-item-name diagnostic items that are set for the last SQL statement executed should be combined into one string. The format is the same as described for the ALL option.

CONDITION

Indicates that all condition-information-item-name diagnostic items that are set for the last SQL statement executed should be combined into one string. If *variable5* or integer is supplied after CONDITION, the format is the same as described above for the ALL option. If *variable5* or integer is not supplied, the format includes a condition number entry at the beginning of the information for that condition in the form:

CONDITION_NUMBER=*x*;item-name=value-converted-to-character;... where *x* is the number of the condition, as shown in the following example:

```
CONDITION_NUMBER=1;RETURNED_SQLSTATE=02000;RETURNED_SQLCODE=100;  
CONDITION_NUMBER=2;RETURNED_SQLSTATE=01004;
```

CONNECTION

Indicates that all connection-information-item-name diagnostic items that are set for the last SQL statement executed should be combined into one string. If *variable5* or integer is supplied after CONNECTION, the format is the same as described for the ALL option. If *variable5* or integer is not supplied, then the format includes a condition number entry at the beginning of the information for that condition in the form:

CONNECTION_NUMBER=*x*;item-name=value-converted-to-character;... where *x* is the number of the connection, as shown in the following example:

```
CONNECTION_NUMBER=1;CONNECTION_NAME=SVL1;DB2_PRODUCT_ID=DSN12015;
```

variable5 or integer

Identifies a variable described in the program in accordance with the rules for declaring variables. The value identifies the diagnostic for which ALL CONDITION or ALL CONNECTION information is requested. The variable specified must be an integer data type or an error occurs. An indicator variable is not allowed when this is a host variable; an error occurs. If a value is specified that is less than or equal to zero or greater than the number of available diagnostics, an error occurs.

Notes for GET DIAGNOSTICS

Effect of the statement in a native SQL routine or trigger:

A successful GET DIAGNOSTICS statement does not change the contents of the diagnostics area, except for DB2_GET_DIAGNOSTICS_DIAGNOSTICS.

If you want information about an error, the GET DIAGNOSTICS statement must be the first executable statement specified in the handler that will handle the error condition.

If you want information about a warning and a handler will get control for the warning condition, the GET DIAGNOSTICS statement must be the first executable statement specified in that handler.

If you want information about a warning and a handler will not get control for the warning condition, the GET DIAGNOSTICS statement must be the next statement executed after that previous statement.

Considerations for the SQLSTATE and SQLCODE SQL variables

A successful GET DIAGNOSTICS statement does not change the value of the SQLSTATE and SQLCODE SQL variables (as used in SQL functions and SQL procedures).

Data types for items:

When a diagnostic item is assigned to a variable, SQL variable, or SQL parameter, the data type of the target must be compatible with the data type of the requested diagnostic item.

Data types for GET DIAGNOSTICS items

Table 239. Data types for GET DIAGNOSTICS items

Type of information	Item	Data type
Statement Information	DB2_GET_DIAGNOSTICS_DIAGNOSTICS	VARCHAR(32672)
	DB2_LAST_ROW	INTEGER
	DB2_NUMBER_PARAMETER_MARKERS	INTEGER
	DB2_NUMBER_RESULT_SETS	INTEGER
	DB2_NUMBER_ROWS	DECIMAL(31,0)
	DB2_RETURN_STATUS	INTEGER
	DB2_SQL_ATTR_CURSOR_HOLD	CHAR(1)
	DB2_SQL_ATTR_CURSOR_ROWSET	CHAR(1)
	DB2_SQL_ATTR_CURSOR_SCROLLABLE	CHAR(1)
	DB2_SQL_ATTR_CURSOR_SENSITIVITY	CHAR(1)
	DB2_SQL_ATTR_CURSOR_TYPE	CHAR(1)
	MORE	CHAR(1)
	NUMBER	INTEGER
	ROW_COUNT	DECIMAL(31,0)
Statement Information	DB2_SQL_NESTING_LEVEL	INTEGER

Table 239. Data types for GET DIAGNOSTICS items (continued)

Type of information	Item	Data type	
Condition Information	CATALOG_NAME	VARCHAR(128)	
	CONDITION_NUMBER	INTEGER	
	CURSOR_NAME	VARCHAR(128)	
	DB2_ERROR_CODE1	INTEGER	
	DB2_ERROR_CODE2	INTEGER	
	DB2_ERROR_CODE3	INTEGER	
	DB2_ERROR_CODE4	INTEGER	
	DB2_INTERNAL_ERROR_POINTER	INTEGER	
	DB2_LINE_NUMBER	INTEGER	
	DB2_MESSAGE_ID	CHAR(10)	
	DB2_MODULE_DETECTING_ERROR	CHAR(8)	
	DB2_ORDINAL_TOKEN_n	VARCHAR(515)	
	DB2_REASON_CODE	INTEGER	
	DB2_RETURNED_SQLCODE	INTEGER	
	DB2_ROW_NUMBER	DECIMAL(31,0)	
	DB2_SQLERRD1	INTEGER	
	DB2_SQLERRD2	INTEGER	
	DB2_SQLERRD3	INTEGER	
	DB2_SQLERRD4	INTEGER	
	DB2_SQLERRD5	INTEGER	
	DB2_SQLERRD6	INTEGER	
	DB2_TOKEN_COUNT	INTEGER	
	MESSAGE_TEXT	VARCHAR(32672)	
	RETURNED_SQLSTATE	CHAR(5)	
	SERVER_NAME	VARCHAR(128)	
	Connection Information	DB2_AUTHENTICATION_TYPE	CHAR(1)
		DB2_AUTHORIZATION_ID	VARCHAR(128)
DB2_CONNECTION_STATE		INTEGER	
DB2_CONNECTION_STATUS		INTEGER	
DB2_ENCRYPTION_TYPE		CHAR(1)	
DB2_PRODUCT_ID		VARCHAR(8)	
DB2_SERVER_CLASS_NAME		CHAR(128)	
Combined Information	ALL	VARCHAR(32672)	

DRDA considerations

The GET DIAGNOSTICS statement is supported from a current Db2 for z/OS client, regardless of the level of the server (a Db2 for z/OS Version 7 or a Db2 for Windows Version 7, for example). When the application is connected to servers that do not support the Open Group Version 3 DRDA standard, the diagnostic information that is returned by the servers is available in the condition information.

Alternative syntax and synonyms:

To provide compatibility with previous releases of Db2 or other products in the Db2 family, Db2 supports the following keywords:

- RETURN_STATUS as a synonym for DB2_RETURN_STATUS
- EXCEPTION as a synonym for CONDITION

Examples for GET DIAGNOSTICS

Example 1

In an application, use the GET DIAGNOSTICS statement to determine how many rows were updated.

```
long rcount;
EXEC SQL UPDATE T1 SET C1 = C1 + 1;
EXEC SQL GET DIAGNOSTICS :rcount = ROW_COUNT;
```

After execution of this code segment, *rcount* will contain the number of rows that were updated.

Example 2

In an application, use the GET DIAGNOSTICS statement to handle multiple SQL Errors.

```
long numerrors, counter;
char retsqlstate[5];
long hva[5];
EXEC SQL INSERT INTO T1 FOR 5 ROWS VALUES (:hva) NOT ATOMIC
CONTINUE ON SQLEXCEPTION;
EXEC SQL GET DIAGNOSTICS :numerrors = NUMBER;
for ( i=1; i < numerrors; i++)
{
    EXEC SQL GET DIAGNOSTICS CONDITION :i :retsqlstate = RETURNED_SQLSTATE;
    ...
}
```

Execution of this code segment sets and prints *retsqlstate* with the SQLSTATE for each error that was encountered in the previous SQL statement.

Example 3

Retrieve information about a connection.

```
EXEC SQL GET DIAGNOSTICS CONDITION :HV_PRODUCT_ID = DB2_PRODUCT_ID;
```

Example 4

Use the GET DIAGNOSTICS statement to retrieve information that is similar to what is returned in the SQLCA

```
EXEC SQL GET DIAGNOSTICS CONDITION 1
:dasqlcode = DB2_RETURNED_SQLCODE,
:datokencnt = DB2_TOKEN_COUNT,
:datoken1 = DB2_ORDINAL_TOKEN_1,
:datoken2 = DB2_ORDINAL_TOKEN_2,
:datoken3 = DB2_ORDINAL_TOKEN_3,
:datoken4 = DB2_ORDINAL_TOKEN_4,
:datoken5 = DB2_ORDINAL_TOKEN_5,
:dasqlerrd1b = DB2_MESSAGE_ID,
:damsgttext = MESSAGE_TEXT,
:dasqlerrp = DB2_MODULE_DETECTING_ERROR,
:dasqlstate = RETURNED_SQLSTATE;
```

Example 5

:Specify the STACKED keyword on a GET DIAGNOSTICS statement that is used within a handler to access information in the diagnostics area that caused the handler to be activated:

```
CREATE PROCEDURE divide2 ( IN numerator INTEGER,
                          IN denominator INTEGER,
                          OUT divide_result INTEGER,
                          OUT divide_error VARCHAR(70))
    LANGUAGE SQL
BEGIN
    DECLARE msg_text      CHAR(70) DEFAULT '';
    DECLARE divide_error  CHAR(70) DEFAULT '';

    DECLARE CONTINUE HANDLER FOR SQLEXCEPTION
    BEGIN
        INSERT .....;  -- insert row into a log table

        -- get diagnostic information for the INSERT statement
        GET CURRENT DIAGNOSTICS CONDITION 1 msg_text = MESSAGE_TEXT;

        -- get information about condition that activated the handler
        GET STACKED DIAGNOSTICS CONDITION 1 divide_error = MESSAGE_TEXT;
    END;

    SET divide_result = numerator/denominator;
END;
```

The first GET DIAGNOSTICS statement obtains diagnostic information about the INSERT statement.

The second GET DIAGNOSTICS statement specifies the STACKED keyword. The use of the STACKED keyword allows access the stacked diagnostics area which contains the diagnostic information for the condition that caused the handler to be activated. The information about the original condition is still accessible within the handler even after another statement has been issued, such as the INSERT statement in the example.

Example 6: The following application logs information whenever a routine is invoked directly by an application rather than indirectly by another routine. The application uses the GET DIAGNOSTICS statement that specifies DB2_SQL_NESTING_LEVEL to obtain the current nesting level, and invokes the LOG_INVOCATION procedure if the nesting level is 1:

```
CREATE PROCEDURE TEST
MODIFIES SQL DATA
LANGUAGE SQL
BEGIN
    DECLARE NESTING_LEVEL INT      DEFAULT 0;

    GET DIAGNOSTICS NESTING_LEVEL = DB2_SQL_NESTING_LEVEL;

    --
    -- If routine is invoked at nesting level 1,
    -- invoke a routine to log the invocation.
    --
    IF (NESTING_LEVEL = 1) THEN
        CALL LOG_INVOCATION();
    END IF;

    --
    -- Remainder of procedure logic
    --
    ...
END
```

GRANT statement

The Db2 GRANT statement grants privileges to authorization IDs. There is a separate form of the statement for each of these classes of privilege:

- [Collection](#)
- [Database](#)
- [Function or stored procedure](#)

- [Package](#)
- [Plan](#)
- [Schema](#)
- [Sequence](#)
- [System](#)
- [Table or view](#)
- [Type or JAR](#)
- [Variable](#)
- [Use](#)

The applicable objects are always at the current server. The grants are recorded in the current server's catalog.

Invocation for GRANT

This statement can be embedded in an application program or issued interactively. It is an executable statement that can be dynamically prepared only if DYNAMICRULES RUN behavior is in effect. For more information, see [“Authorization IDs and dynamic SQL”](#) on page 94.

If the authorization mechanism was not activated when the Db2 subsystem was installed, an error condition occurs.

Authorization for GRANT

To grant a privilege P, the privilege set must include one of the following:

- The privilege P WITH GRANT OPTION
- Ownership of the object on which P is a privilege
- SECADM authority

Note: If installation parameter SEPARATE SECURITY is NO, SYSADM authority has implicit SECADM authority.

- ACCESSCTRL authority

The presence of ACCESSCTRL authority in the privilege set allows the granting of all authorities except:

- System DBADM
- CREATE_SECURE_OBJECT privilege
- DATAACCESS
- ACCESSCTRL

Note: If installation parameter SEPARATE SECURITY is NO, SYSCTRL authority has implicit ACCESSCTRL authority that allows the granting of all privileges except:

- DBADM on databases
- DELETE, INSERT, SELECT, and UPDATE on user tables or views
- EXECUTE on plans, packages, functions, or stored procedures
- PACKADM on collections
- SYSADM authority
- USAGE on distinct types, JARs, and sequences
- READ, WRITE on global variables

- Installation SYSOPR authority (when the current SQLID of the process is set to SYSINSTL)

The Installation SYSOPR authority with the current SQLID set to SYSINSTL allows the granting of the following privileges:

- All database, table, and table space privileges on objects in database DSNDB04 and system databases DSNRGFDB, DSNRLST, DSNOPTDB, DSNMDCDB, DSNADMDB, DSNATPDB, SN5JSDB, DSNMQDB, SYSIBMTA, SYSIBMTS, and DSNXSR
- The USE privilege on buffer pools and storage groups
- All privileges on plans that begin with 'DSN'
- All privileges on packages whose collection-ID and package-name begin with 'DSN'
- The EXECUTE privilege on system-defined routines.

To grant the CREATE_SECURE_OBJECT system privilege, the privileges that are held by the authorization ID of the statement must include SECADM authority.

Except for views, the GRANT option for privileges on a table is also inherent in DBADM authority for its database, provided DBADM authority was acquired with the GRANT option. See [“CREATE VIEW statement”](#) on page 1812 for a description of the rules that apply to views.

If the statement is embedded in an application program, the privilege set is the privileges that are held by the owner of the plan or package. The owner can be a role. If the statement is dynamically prepared, the privilege set is the privileges that are held by the SQL authorization ID of the process. However, if the process is running in a trusted context that is defined with the ROLE AS OBJECT OWNER CLAUSE, the privilege set is the privileges that are held by the role in effect.

Syntax for GRANT

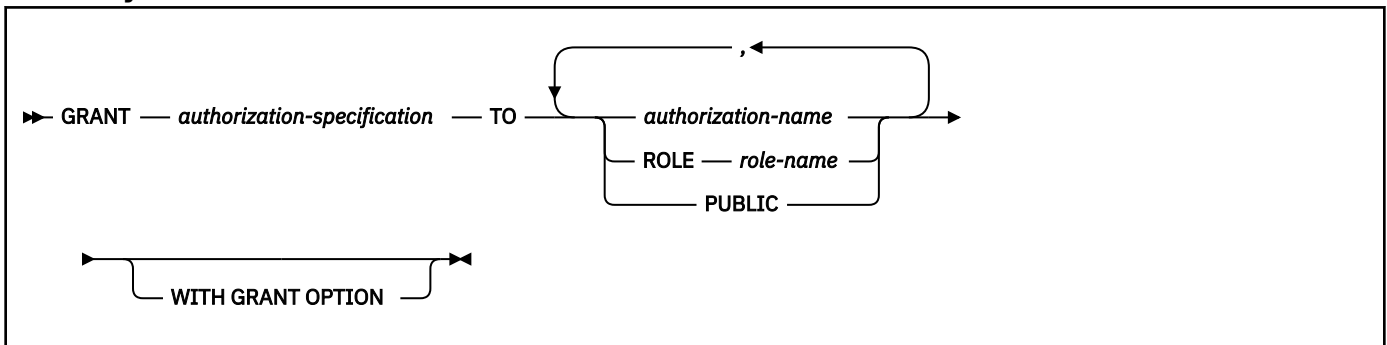

Description for GRANT

authorization-specification

Specifies one or more privileges for the class of privilege. The same privilege must not be specified more than once.

TO

Specifies to what authorization IDs the privileges are granted.

authorization-name,...

Lists one or more authorization IDs.

ROLE role-name

Lists one or more role names. Each name must identify a role that exists at the current server.

The value of the CURRENT RULES special register determines whether you can use the ID or role of the GRANT statement itself (to grant privileges to yourself). When CURRENT RULES is:

DB2

You cannot use the ID or role of the GRANT statement.

STD

You can use the ID or role of the GRANT statement.

PUBLIC

Grants the privileges to all users at the current server, including database requesters using DRDA access.

CREATE_SECURE_OBJECT must not be granted to PUBLIC.

ACCESSCTRL, DATAACCESS and system DBADM authorities cannot be granted to PUBLIC.

WITH GRANT OPTION

Allows the named users to grant the privileges to others. Granting an administrative authority with this option allows the user to specifically grant any privilege belonging to that authority. If you omit WITH GRANT OPTION, the named users cannot grant the privileges to others unless they have that authority from some other source.

GRANT authority cannot be passed to PUBLIC. When WITH GRANT OPTION is used with PUBLIC, a warning is issued, and the named privileges are granted, but without GRANT authority.

If you grant the CREATE_SECURE_OBJECT system privilege, the WITH GRANT OPTION clause is ignored because the CREATE_SECURE_OBJECT system privilege cannot be granted to others.

GRANT ACCESSCTRL, DATAACCESS and system DBADM authorities cannot be passed to others. If WITH GRANT OPTION is used when granting these authorities, a warning is issued and the named authorities are granted, but without GRANT authority.

Notes for GRANT

A *grant* is the granting of a specific privilege by a specific grantor to a specific grantee. The grantor for a given GRANT statement is the authorization ID for the privilege set; that is, the SQL authorization ID of the process or a role, or the authorization ID of the owner of the plan or package. Grant statements that are made in a trusted context that is defined with the ROLE AS OBJECT OWNER clause result in the grantor being the role that is in effect. If the statement is prepared dynamically, the grantor is the role that is associated with the ID that is running the statement. If the statement is embedded in an application program that was bound in a trusted context that was defined with the ROLE AS OBJECT OWNER clause the owner of the plan or package is a role which is the grantor. If the ROLE AS OBJECT OWNER clause is not specified for the trusted context, the grantor is the authorization ID of the process.

The grantee, as recorded in the catalog, is an authorization ID or PUBLIC. Any instances of PUBLIC* in the catalog mean the same as PUBLIC.

Duplicate grants from the same grantor are not recorded in the catalog. Otherwise, the result of executing a GRANT statement is recorded as one or more grants in the current server's catalog.

If more than one privilege or *authorization-name* is specified after the TO keyword and one of the grants is in error, execution of the statement is stopped and no grants are made. The status of the privilege or privileges granted is recorded in the catalog for each *authorization-name*.

Different grantors can grant the same privilege to a single grantee. The grantee retains that privilege as long as one or more of those grants are recorded in the catalog. Privileges that imply other privileges are also termed *authorities*. Grants are removed from the catalog by executing SQL REVOKE statements.

Whenever a grant is made for a database, distinct type, package, plan, schema, stored procedure, table, trigger, user-defined function, view, or USE privilege for an object that does not exist, an SQL return code is issued and the grant is not made.

Related tasks

[Granting privileges with the GRANT statement \(Managing Security\)](#)

GRANT statement (collection privileges)

This form of the GRANT statement grants privileges on collections.

Syntax for GRANT (collection privileges)

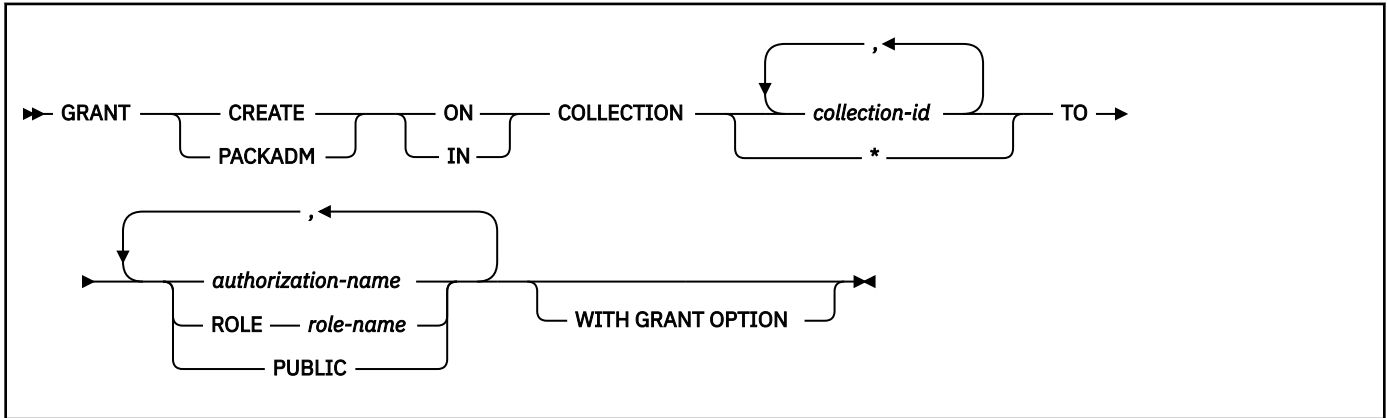

Description for GRANT (collection privileges)

CREATE IN

Grants the privilege to use the BIND subcommand to create packages in the designated collections.

The word ON can be used instead of IN.

PACKADM ON

Grants package administrator authority for the designated collections.

The word IN can be used instead of ON.

COLLECTION *collection-id*,...

Identifies the collections on which the specified privilege is granted. The collections do not have to exist.

COLLECTION *

Indicates that the specified privilege is granted on all collections including those that do not currently exist.

TO

Refer to [“GRANT statement” on page 1963](#) for a description of the TO clause.

WITH GRANT OPTION

Refer to [“GRANT statement” on page 1963](#) for a description of the WITH GRANT OPTION clause.

Examples for GRANT (collection privileges)

Example 1: Grant the privilege to create new packages in collections QAACLONE and DSN8CC61 to CLARK.

```
GRANT CREATE IN COLLECTION QAACLONE, DSN8CC61 TO CLARK;
```

Example 2: Grant the privileges to create new packages in collection DSN8CC91 to role ROLE1:

```
GRANT CREATE IN COLLECTION DSN8CC91 TO ROLE ROLE1;
```

GRANT statement (database privileges)

This form of the GRANT statement grants privileges on databases.

Syntax for GRANT (database privileges)

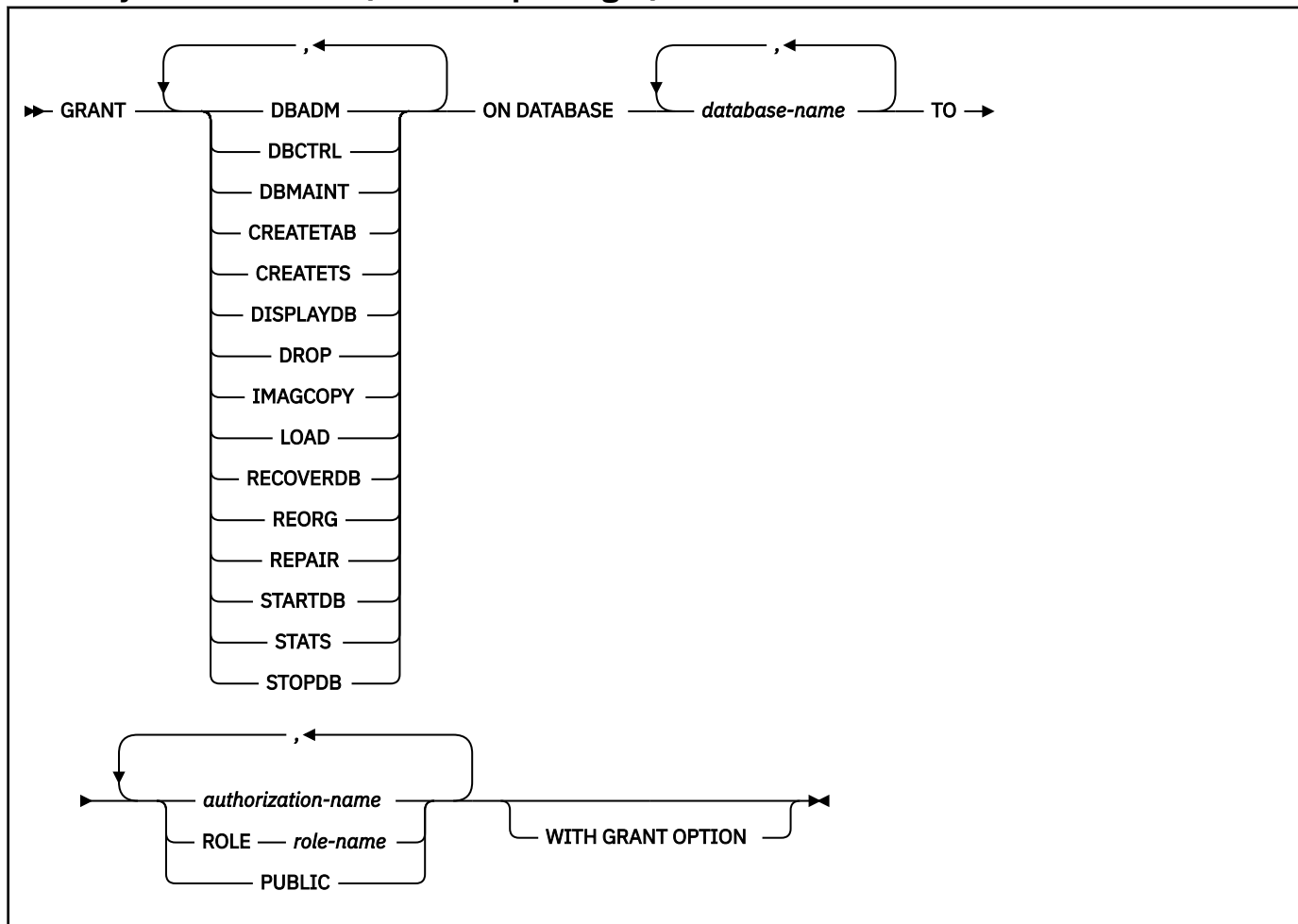

Description for GRANT (database privileges)

Each keyword listed grants the privilege described, but only as it applies to or within the databases named in the statement.

DBADM

Grants the database administrator authority.

DBCTRL

Grants the database control authority.

DBMAINT

Grants the database maintenance authority.

CREATETAB

Grants the privilege to create new tables. To create tables in an implicitly created database, CREATETAB privileges are needed on the DSNDB04 database. For a work file database, PUBLIC implicitly has the CREATETAB privilege (without GRANT authority) to define declared temporary tables; this privilege is not recorded in the Db2 catalog, and it cannot be revoked.

CREATETS

Grants the privilege to create new table spaces.

DISPLAYDB

Grants the privilege to issue the DISPLAY DATABASE command.

DROP

Grants the privilege to issue the DROP or ALTER DATABASE statements for the designated databases.

IMAGCOPY

Grants the privilege to run the COPY, MERGECOPY, and QUIESCE utilities against table spaces of the specified databases, and to run the MODIFY RECOVERY utility.

LOAD

Grants the privilege to use the LOAD utility to load tables.

RECOVERDB

Grants the privilege to use the RECOVER and REPORT utilities to recover table spaces and indexes.

REORG

Grants the privilege to use the REORG utility to reorganize table spaces and indexes.

REPAIR

Grants the privilege to use the REPAIR and DIAGNOSE utilities.

STARTDB

Grants the privilege to issue the START DATABASE command.

STATS

Grants the privilege to use the RUNSTATS utility to update statistics, the CHECK utility to test whether indexes are consistent with the data they index, and the MODIFY STATISTICS utility to delete unwanted statistics history records from the corresponding catalog tables.

STOPDB

Grants the privilege to issue the STOP DATABASE command.

ON DATABASE *database-name*,...

Identifies databases on which privileges are to be granted. For each named database, the grantor must have all the specified privileges with the GRANT option. Each name must identify a database that exists at the current server. DSNDB01 must not be identified; however, a grant of a privilege on DSNDB06 implies the granting of the same privilege on DSNDB01 for utility operations only.

Database privileges granted on DSNDB04 are applicable to all implicitly created databases. This means that a user with the STOPDB privilege on DSNDB04 can also stop database objects in any implicitly created database. Similarly, having DBADM on DSNDB04 allows access to all tables in all implicitly created databases. However, having a database privilege on DSNDB04 does not allow granting of this privilege on an implicitly created database to others.

TO

Refer to [“GRANT statement” on page 1963](#) for a description of the TO clause.

WITH GRANT OPTION

Refer to [“GRANT statement” on page 1963](#) for a description of the WITH GRANT OPTION clause.

Examples for GRANT (database privileges)

Example 1: Grant drop privileges on database DSN8D12A to user PEREZ.

```
GRANT DROP
  ON DATABASE DSN8D12A
  TO PEREZ;
```

Example 2: Grant repair privileges on database DSN8D12A to all local users.

```
GRANT REPAIR
  ON DATABASE DSN8D12A
  TO PUBLIC;
```

Example 3: Grant authority to create new tables and load tables in database DSN8D12A to users WALKER, PIANKA, and FUJIMOTO, and give them grant privileges.

```
GRANT CREATETAB,LOAD
ON DATABASE DSN8D12A
TO WALKER,PIANKA,FUJIMOTO
WITH GRANT OPTION;
```

Example 4: Grant load privileges to database DSN9D91A to role ROLE1:

```
GRANT LOAD
ON DATABASE DSN9D91A
TO ROLE ROLE1;
```

GRANT statement (function or procedure privileges)

This form of the GRANT statement grants privileges on user-defined functions, cast functions that are generated for distinct types, array types, and stored procedures.

Syntax for GRANT (function or procedure privileges)

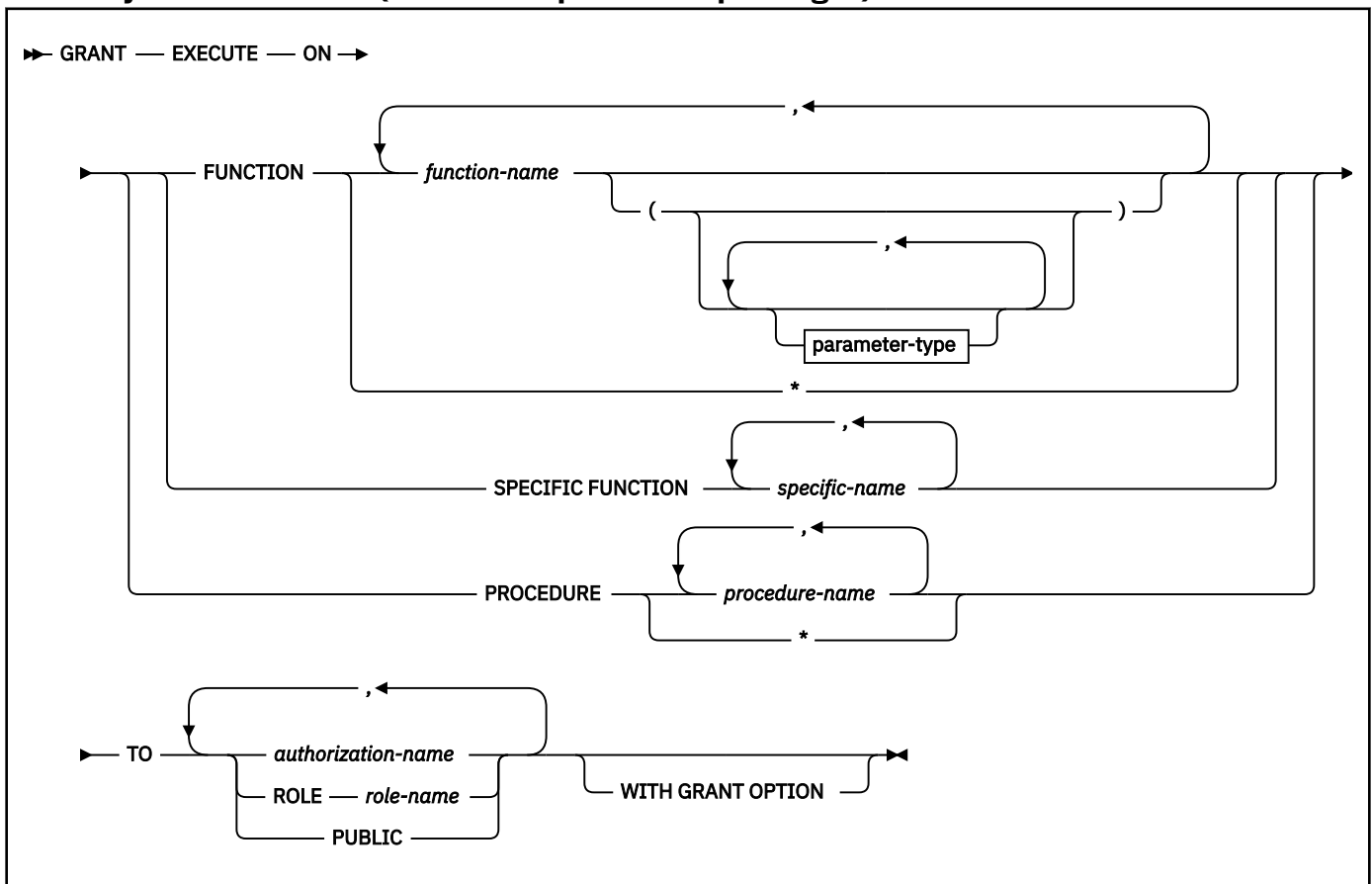

parameter-type:

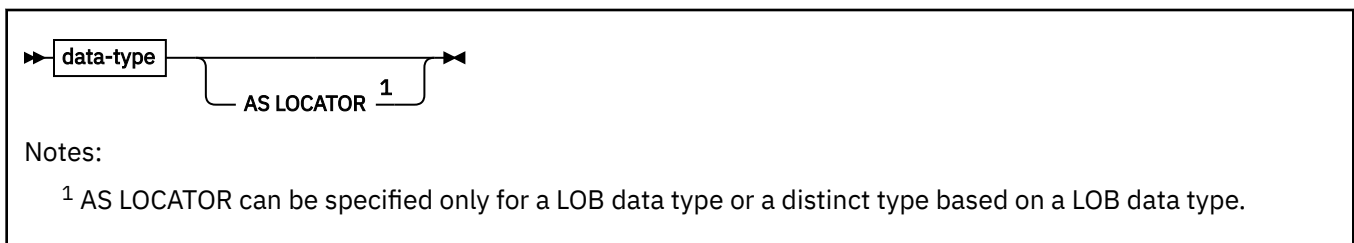

data-type:

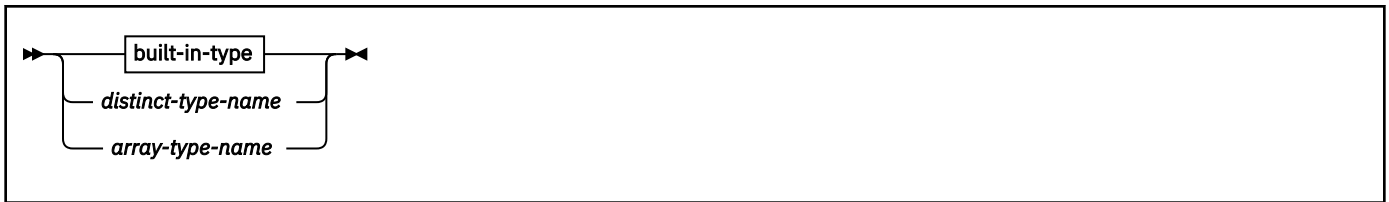

built-in-type:

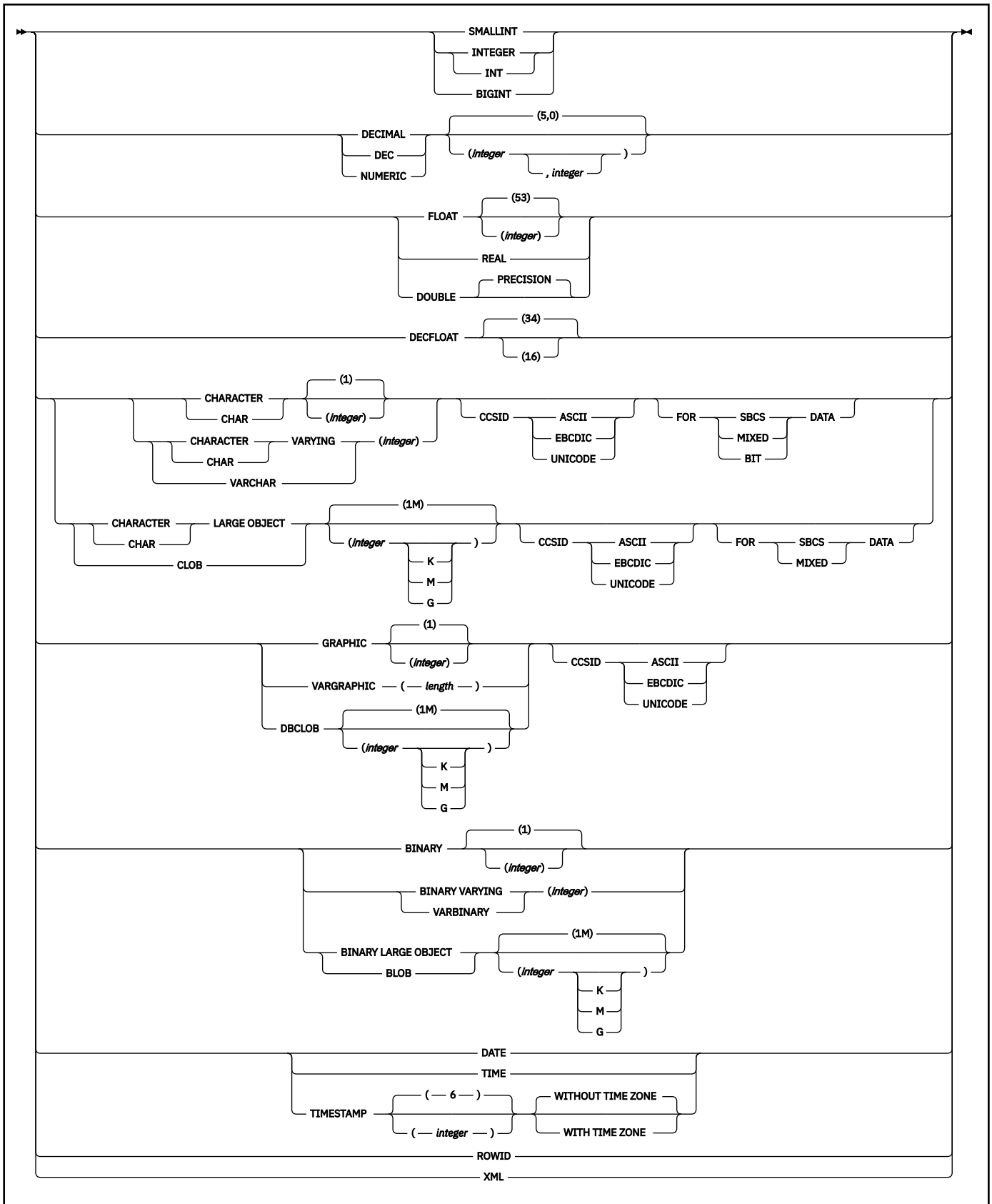

Description for GRANT (function or procedure privileges)

EXECUTE

Grants the privilege to run the identified user-defined function, cast function that was generated for a distinct type, or stored procedure.

FUNCTION or SPECIFIC FUNCTION

Identifies the function on which the privilege is granted. The function must exist at the current server, and it must be a function that was defined with the CREATE FUNCTION statement or a cast function that was generated by a CREATE TYPE statement. The function can be identified by name, function signature, or specific name.

If the function was defined with a table parameter (the LIKE TABLE was specified in the CREATE FUNCTION statement to indicate that one of the input parameters is a transition table), the function signature cannot be used to identify the function. Instead, identify the function with its function name, if unique, or with its specific name.

FUNCTION *function-name*

Identifies the function by its name. The *function-name* must identify exactly one function. The function can have any number of parameters defined for it. If there is more than one function of the specified name in the specified or implicit schema, an error is returned.

An asterisk (*) can be specified for an unqualified function name. The function can be identified as a qualified or unqualified *function-name*. For example, * indicates that the privilege is granted on all the functions in the default schema, including those that do not currently exist. *schema-name.** indicates that the privilege is granted on all the functions in the specified schema, including those that do not currently exist. SYSADM authority is required if * or *schema-name.** is specified. Specifying an asterisk does not affect any EXECUTE privileges that are already granted on a function.

FUNCTION *function-name (parameter-type,...)*

Identifies the function by its function signature, which uniquely identifies the function. The *function-name (parameter-type, ...)* must identify a function with the specified function signature. The specified parameters must match the data types in the corresponding position that were specified when the function was created. The number of data types, and the logical concatenation of the data types is used to identify the specific function instance on which the privilege is to be granted. Synonyms for data types are considered a match.

If the function was defined with a table parameter (the LIKE TABLE *name* AS LOCATOR clause was specified in the CREATE FUNCTION statement to indicate that one of the input parameters is a transition table), the function signature cannot be used to uniquely identify the function. Instead, use one of the other syntax variations to identify the function with its function name, if unique, or its specific name.

If *function-name ()* is specified, the function identified must have zero parameters.

function-name

Identifies the name of the function. If you do not explicitly qualify the function name with a schema name, the function name is implicitly qualified with a schema name as described in the preceding description for FUNCTION *function-name*.

(parameter-type,...)

Identifies the parameters of the function.

If an unqualified distinct type name is specified, Db2 searches the SQL path to resolve the schema name for the distinct type.

For data types that have a length, precision, or scale attribute, use one of the following:

- Empty parentheses indicate that the database manager ignores the attribute when determining whether the data types match. For example, DEC() will be considered a match for a parameter of a function defined with a data type of DEC(7,2). Similarly, DECFLOAT() will be considered a match for DECFLOAT(16) or DECFLOAT(34). However, FLOAT cannot be

specified with empty parenthesis because its parameter value indicates a specific data type (REAL or DOUBLE).

- If a specific value for a length, precision, or scale attribute is specified, the value must exactly match the value that was specified (implicitly or explicitly) in the CREATE FUNCTION statement. If the data type is FLOAT, the precision does not have to exactly match the value that was specified because matching is based on the data type (REAL or DOUBLE).
- If length, precision, or scale is not explicitly specified, and empty parentheses are not specified, the default attributes of the data type are implied. The implicit length must exactly match the value that was specified (implicitly or explicitly) in the CREATE FUNCTION statement.

For data types with a subtype or encoding scheme attribute, specifying the FOR *subtype* DATA clause or the CCSID clause is optional. Omission of either clause indicates that Db2 ignores the attribute when determining whether the data types match. If you specify either clause, it must match the value that was implicitly or explicitly specified in the CREATE FUNCTION statement.

AS LOCATOR

Specifies that the function is defined to receive a locator for this parameter. If AS LOCATOR is specified, the data type must be a LOB or a distinct type based on a LOB.

SPECIFIC FUNCTION *specific-name*

Identifies the function by its specific name. The *specific-name* must identify a specific function that exists at the current server.

PROCEDURE *procedure-name*

Identifies a stored procedure that is defined at the current server. The name, including the implicit or explicit schema name, must identify a stored procedure that exists at the current server.

An asterisk (*) can be specified for an unqualified procedure name. The procedure can be identified as a qualified or unqualified *procedure-name*. For example, * indicates that the privilege is granted on all the procedures in the default schema, including those that do not currently exist. *schema-name.** indicates that the privilege is granted on all the procedures in the specified schema, including those that do not currently exist. SYSADM authority is required if * or *schema-name.** is specified. Specifying an asterisk does not affect any EXECUTE privileges that are already granted on a procedure.

TO

Refer to [“GRANT statement” on page 1963](#) for a description of the TO clause.

WITH GRANT OPTION

Refer to [“GRANT statement” on page 1963](#) for a description of the WITH GRANT OPTION clause.

Examples for GRANT (function or procedure privileges)

Example 1: Grant the EXECUTE privilege on function CALC_SALARY to user JONES. Assume that there is only one function in the schema with function name CALC_SALARY.

```
GRANT EXECUTE ON FUNCTION CALC_SALARY TO JONES;
```

Example 2: Grant the EXECUTE privilege on procedure VACATION_ACCR to all users at the current server.

```
GRANT EXECUTE ON PROCEDURE VACATION_ACCR TO PUBLIC;
```

Example 3: Grant the EXECUTE privilege on function DEPT_TOTALS to the administrative assistant and give the assistant the ability to grant the EXECUTE privilege on this function to others. The function has the specific name DEPT85_TOT. Assume that the schema has more than one function that is named DEPT_TOTALS.

```
GRANT EXECUTE ON SPECIFIC FUNCTION DEPT85_TOT TO ADMIN_A  
WITH GRANT OPTION;
```

Example 4: Grant the EXECUTE privilege on function NEW_DEPT_HIRES to HR (Human Resources). The function has two input parameters with data types of INTEGER and CHAR(10), respectively. Assume that the schema has more than one function that is named NEW_DEPT_HIRES.

```
GRANT EXECUTE ON FUNCTION NEW_DEPT_HIRES (INTEGER, CHAR(10))
  TO HR;
```

You can also code the CHAR(10) data type as CHAR().

Example 5: Grant the EXECUTE privilege on function FIND_EMPDEPT to role ROLE1:

```
GRANT EXECUTE ON FUNCTION FIND_EMPDEPT TO ROLE ROLE1;
```

GRANT statement (package privileges)

This form of the GRANT statement grants privileges on packages.

Syntax for GRANT (package privileges)

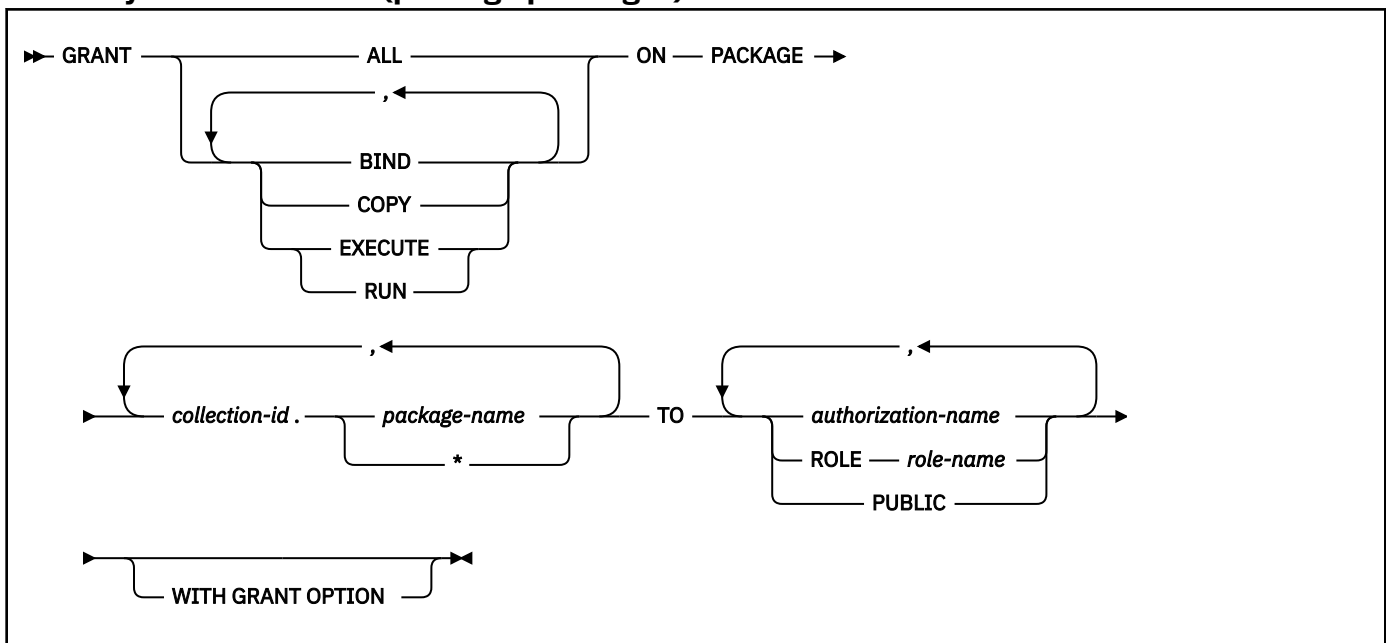

Description for GRANT (package privileges)

BIND

Grants the privilege to use the BIND and REBIND subcommands for the designated packages.

The BIND package privilege can also be used to allow a user to add a new version of an existing package. For details on the authorization required to create new packages and new versions of existing packages, see “Notes for GRANT (package privileges)” on page 1976.

COPY

Grants the privilege to use the COPY option of the BIND subcommand for the designated packages.

EXECUTE

Grants the privilege to run application programs that use the designated packages and to specify the packages following PKLIST for the BIND PLAN and REBIND PLAN commands. RUN is an alternate name for the same privilege.

ALL

Grants all package privileges for which you have GRANT authority for the packages named in the ON clause.

ON PACKAGE *collection-id.package-name,...*

Identifies packages for which you are granting privileges. The granting of a package privilege applies to all versions of a package. The list can simultaneously contain items of the following two forms:

- *collection-id.package-name* explicitly identifies a single package. The name must identify a package that exists at the current server.
- *collection-id.** applies to every package in the indicated collection. This includes packages that currently exist and future packages. The grant applies to a collection at the current server, but the *collection-id* does not have to identify a collection that exists when the grant is made.

To grant a privilege in this form requires PACKADM with the WITH GRANT OPTION over the collection or all collections, SYSADM, or SYSCTRL authority. Because of this fact, WITH GRANT OPTION, if included in the statement, is ignored for grants of this form, but not for grants for specific packages.

TO

Refer to “GRANT statement” on page 1963 for a description of the TO clause.

WITH GRANT OPTION

Refer to “GRANT statement” on page 1963 for a description of the WITH GRANT OPTION clause.

Notes for GRANT (package privileges)

The authorization required to add a new package or a new version of an existing package depends on the value of field BIND NEW PACKAGE on installation panel DSNTIPP. The default value is BINDADD.

If the value of BIND NEW PACKAGE is BINDADD, the owner must have one of the following to add a new package or a new version of an existing package to a collection:

- The BINDADD system privilege and either the CREATE IN privilege or PACKADM authority for the collection or for all collections
- SYSADM or SYSCTRL authority

If the value of BIND NEW PACKAGE is BIND, the owner must have one of the following to add a new package or a new version of an existing package to a collection:

- The BINDADD system privilege and either the CREATE IN privilege or PACKADM authority for the collection or for all collections
- SYSADM or SYSCTRL authority
- PACKADM authority for the collection or for all collections
- Users with the BIND package privilege can also add a new version of an existing package

Alternative syntax and synonyms: To provide compatibility with previous releases of Db2 or other products in the Db2 family, Db2 supports specifying PROGRAM as a synonym for PACKAGE.

Examples for GRANT (package privileges)

Example 1: Grant the privilege to copy all packages in collection DSN8CC61 to LEWIS.

```
GRANT COPY ON PACKAGE DSN8CC61.* TO LEWIS;
```

Example 2: You have the BIND privilege with GRANT authority over the package CLCT1.PKG1. You have the EXECUTE privilege with GRANT authority over the package CLCT2.PKG2. You have no other privileges with GRANT authority over any package in the collections CLCT1 AND CLCT2. Hence, the following statement, when executed by you, grants LEWIS the BIND privilege on CLCT1.PKG1 and the EXECUTE privilege on CLCT2.PKG2, and makes no other grant. The privileges granted include no GRANT authority.

```
GRANT ALL ON PACKAGE CLCT1.PKG1, CLCT2.PKG2 TO JONES;
```

Example 3: Grant the privileges to run all packages in collection DSN9CC13 to role ROLE1:

```
GRANT EXECUTE ON PACKAGE DSN9CC13.* TO ROLE ROLE1;
```

GRANT statement (plan privileges)

This form of the GRANT statement grants privileges on plans.

Syntax for GRANT (plan privileges)

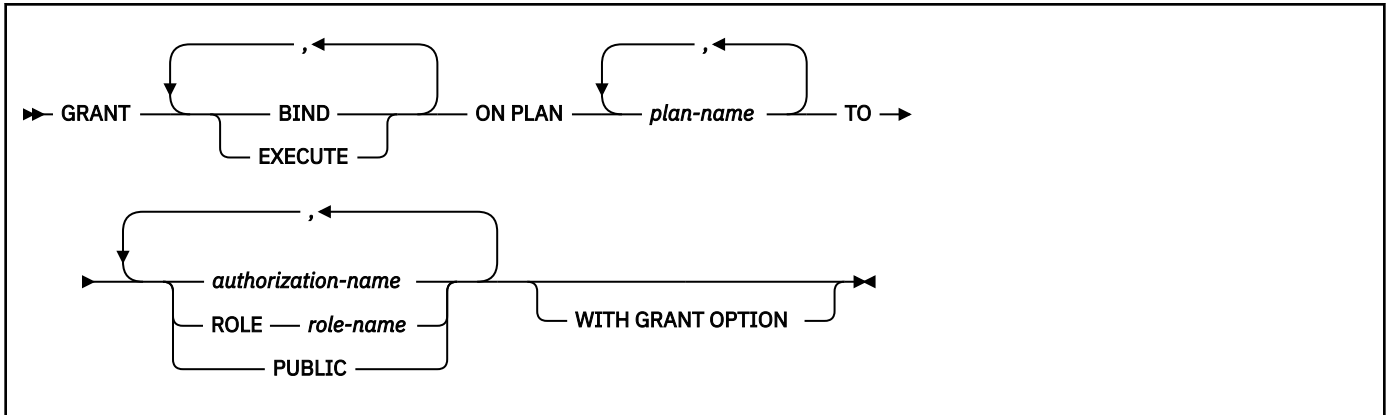

Description for GRANT (plan privileges)

BIND

Grants the privilege to use the BIND, REBIND, and FREE subcommands for the identified plans. (The authority to create new plans using BIND ADD is a system privilege.)

EXECUTE

Grants the privilege to run programs that use the identified plans.

ON PLAN *plan-name*,...

Identifies the application plans on which the privileges are granted. For each identified plan, you must have all specified privileges with the GRANT option.

TO

Refer to “GRANT statement” on page 1963 for a description of the TO clause.

WITH GRANT OPTION

Refer to “GRANT statement” on page 1963 for a description of the WITH GRANT OPTION clause.

Examples for GRANT (plan privileges)

Example 1: Grant the privilege to bind plan DSN8IP12 to user JONES.

```
GRANT BIND ON PLAN DSN8IP12 TO JONES;
```

Example 2: Grant privileges to bind and execute plan DSN8CP12 to all users at the current server.

```
GRANT BIND,EXECUTE ON PLAN DSN8CP12 TO PUBLIC;
```

Example 3: Grant the privilege to execute plan DSN8CP12 to users ADAMSON and BROWN with grant option.

```
GRANT EXECUTE ON PLAN DSN8CP12 TO ADAMSON,BROWN WITH GRANT OPTION;
```

Example 4: Grant the privileges to bind the DSN91PLN plan to role ROLE1:

```
GRANT BIND ON PLAN DSN91PLN TO ROLE ROLE1;
```

GRANT statement (schema privileges)

This form of the GRANT statement grants privileges on schemas.

Syntax for GRANT (schema privileges)

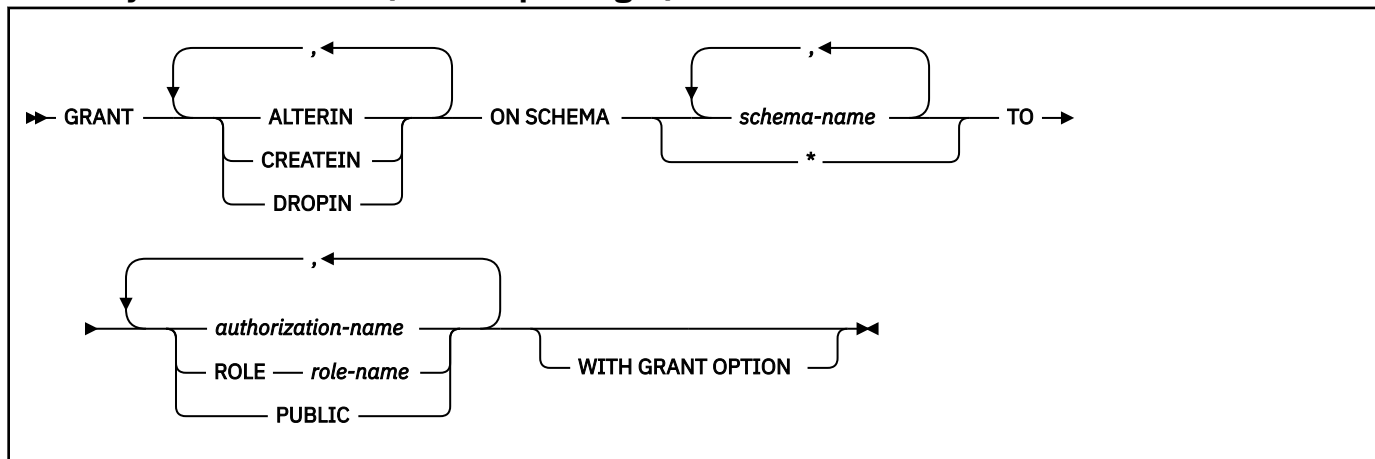

Description for GRANT (schema privileges)

ALTERIN

Grants the privilege to alter stored procedures and user-defined functions, or specify a comment for distinct types, cast functions that are generated for distinct types, sequences, stored procedures, triggers, and user-defined functions in the designated schemas.

CREATEIN

Grants the privilege to create distinct types, sequences, stored procedures, triggers, and user-defined functions in the designated schemas.

DROPIN

Grants the privilege to drop distinct types, sequences, stored procedures, triggers, and user-defined functions in the designated schemas.

SCHEMA *schema-name*

Identifies the schemas on which the privilege is granted. The schemas do not need to exist when the privilege is granted.

SCHEMA *

Indicates that the specified privilege is granted on all schemas including those that do not currently exist.

TO

Refer to [“GRANT statement”](#) on page 1963 for a description of the TO clause.

WITH GRANT OPTION

Refer to [“GRANT statement”](#) on page 1963 for a description of the WITH GRANT OPTION clause.

Notes for GRANT (schema privileges)

Grant on SYSPUBLIC:

Privileges can be granted on the reserved schema SYSPUBLIC. Granting CREATEIN privilege allows the user to create a public alias and granting DROPIN privilege allows the user to drop any public alias.

Examples for GRANT (schema privileges)

Example 1: Grant the CREATEIN privilege on schema T_SCORES to user JONES.

```
GRANT CREATEIN ON SCHEMA T_SCORES TO JONES;
```

Example 2: Grant the CREATEIN privilege on schema VAC to all users at the current server.

```
GRANT CREATEIN ON SCHEMA VAC TO PUBLIC;
```

Example 3: Grant the ALTERIN privilege on schema DEPT to the administrative assistant and give the grantee the ability to grant ALTERIN privileges on this schema to others.

```
GRANT ALTERIN ON SCHEMA DEPT TO ADMIN_A  
WITH GRANT OPTION;
```

Example 4: Grant the CREATEIN, ALTERIN, and DROPIN privileges on schemas NEW_HIRE, PROMO, and RESIGN to HR (Human Resources).

```
GRANT CREATEIN, ALTERIN, DROPIN ON SCHEMA NEW_HIRE, PROMO, RESIGN TO HR;
```

Example 5: Grant the ALTERIN privileges on the EMPLOYEE schema to role ROLE1:

```
GRANT ALTERIN ON SCHEMA EMPLOYEE TO ROLE ROLE1;
```

GRANT statement (sequence privileges)

This form of the GRANT statement grants privileges on a user-defined sequence.

Syntax for GRANT (sequence privileges)

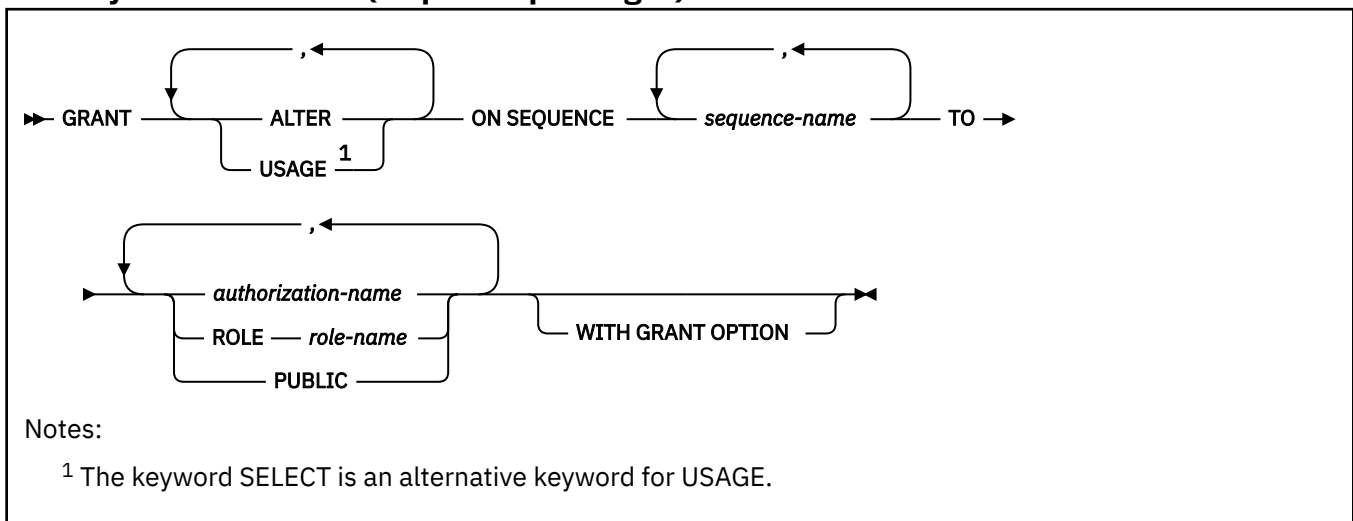

Description for GRANT (sequence privileges)

ALTER

Grants the privilege to alter a sequence or record a comment on a sequence.

USAGE

Grants the USAGE privilege to use a sequence. This privilege is needed when the NEXT VALUE or PREVIOUS VALUE expression is invoked for a sequence name.

SEQUENCE *sequence-name*

Identifies the sequence. The name, including the implicit or explicit schema qualifier, must uniquely identify an existing sequence at the current server. If no sequence by this name exists in the explicitly or implicitly specified schema, an error occurs. *sequence-name* must not be the name of an internal sequence object that is used by Db2.

TO

Refer to “GRANT statement” on page 1963 for a description of the TO clause.

WITH GRANT OPTION

Refer to “GRANT statement” on page 1963 for a description of the WITH GRANT OPTION clause.

Examples for GRANT (sequence privileges)

Example 1: Grant USAGE privilege on sequence MYNUM to user JONES.

```
GRANT USAGE  
ON SEQUENCE MYNUM  
TO JONES;
```

Example 2: Grant USAGE privileges on sequence ORDER_SEQ to role ROLE1:

```
GRANT USAGE ON SEQUENCE ORDER_SEQ TO ROLE ROLE1;
```

GRANT statement (system privileges)

This form of the GRANT statement grants system privileges.

Syntax for GRANT (system privileges)

► GRANT →

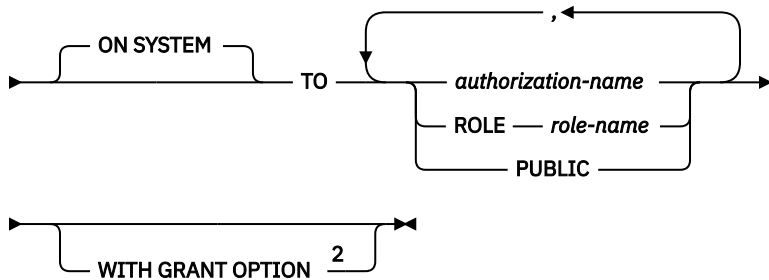
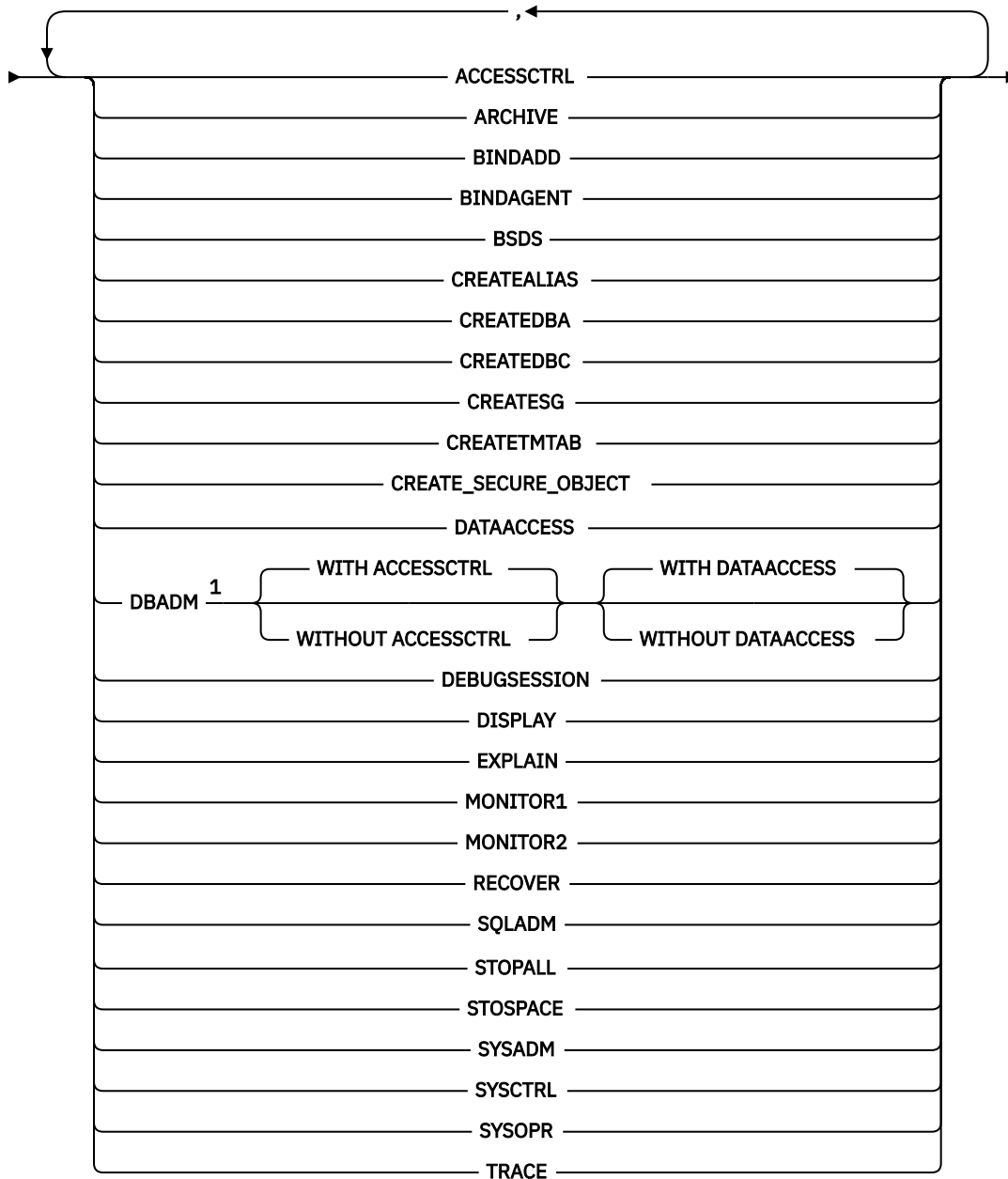

Notes:

¹ The ACCESSCTRL and DATAACCESS clauses can be specified in any order.

² The WITH GRANT OPTION can be specified but is ignored for DBADM, DATAACCESS, and ACCESSCTRL. The WITH GRANT OPTION is also ignored if BINDAGENT grant is issued by SECADM authority.

Description for GRANT (system privileges)

ACCESSCTRL

Grants the ACCESSCTRL authority. ACCESSCTRL allows the user to grant all authorities and privileges, except system DBADM, DATAACCESS, ACCESSCTRL, and privileges on security related objects.

A warning is issued if the WITH GRANT OPTION is specified when granting this authority.

ACCESSCTRL cannot be granted to PUBLIC.

ARCHIVE

Grants the privilege to use the ARCHIVE LOG and SET LOG commands.

BINDADD

Grants the privilege to create plans and packages by using the BIND subcommand with the ADD option.

BINDAGENT

Grants the privilege to issue the BIND, FREE PACKAGE, or REBIND commands for plans and packages and the DROP PACKAGE statement on behalf of the grantor. The privilege also allows the holder to copy and replace plans and packages on behalf of the grantor.

A warning is issued if WITH GRANT OPTION is specified when granting this privilege.

When BINDAGENT is granted using SECADM authority, it grants the privilege to issue the BIND or REBIND commands for plans and packages by specifying any owner.

This SECADM granted BINDAGENT privilege will not allow the following:

- Rebind the package or plan without specifying OWNER keyword
- FREE PACKAGE or FREE PLAN
- COPY PACKAGE
- DROP PACKAGE

The BINDAGENT privilege cannot be granted to PUBLIC using SECADM authority.

If WITH GRANT OPTION is specified when granting this privilege using SECADM authority, the option is ignored.

BSDS

Grants the privilege to issue the RECOVER BSDS command.

CREATEALIAS

Grants the privilege to use the CREATE ALIAS statement.

CREATEDBA

Grants the privilege to issue the CREATE DATABASE statement and acquire DBADM authority over those databases.

CREATEDBC

Grants the privilege to issue the CREATE DATABASE statement and acquire DBCTRL authority over those databases.

CREATESG

Grants the privilege to create new storage groups.

CREATETMTAB

Grants the privilege to use the CREATE GLOBAL TEMPORARY TABLE statement.

CREATE_SECURE_OBJECT

Grants the privilege to create a secure object.

DATAACCESS

Grants the DATAACCESS authority. DATAACCESS allows the user to access data in all user tables, views, materialized query tables, and global variables in a Db2 subsystem, and allows the user to execute plans, packages, functions, and procedures, and use sequences.

DATAACCESS authority implicitly includes the SELECT privilege on all catalog tables and implicitly includes the INSERT, DELETE, and UPDATE privileges on updatable catalog tables, except for the SYSIBM.SYSAUDITPOLICIES catalog table.

A warning is issued if the WITH GRANT OPTION is specified when granting this authority.

DATAACCESS cannot be granted to PUBLIC.

DBADM

Grants the DBADM authority. DBADM allows the user to manage all objects in the Db2 subsystem, except security objects.

A warning is issued if the WITH GRANT OPTION is specified when granting this authority.

DBADM cannot be granted to PUBLIC.

WITH ACCESSCTRL

Specifies that the ACCESSCTRL authority is granted along with the system DBADM authority. ACCESSCTRL allows system DBADM to grant all authorities and privileges, except system DBADM, DATAACCESS, ACCESSCTRL authorities and privileges on security related objects. ACCESSCTRL can be used to REVOKE privileges using the BY clause.

WITH ACCESSCTRL is the default.

WITHOUT ACCESSCTRL

Specifies that system DBADM authority is not granted the ACCESSCTRL authority.

WITH DATAACCESS

Specifies that the DATAACCESS authority is granted along with the system DBADM authority. DATAACCESS allows the system DBADM to access data in all user tables, views, and materialized query tables in a Db2 subsystem and allows the user to execute plans, packages, functions, and procedures.

WITH DATAACCESS is the default.

WITHOUT DATAACCESS

Specifies that system DBADM authority is not granted the DATAACCESS authority.

DISPLAY

Grants the privilege to issue the DISPLAY commands, with the following exceptions:

- DISPLAY DYNQUERYCAPTURE
- DISPLAY ML
- DISPLAY PROFILE
- DISPLAY RLIMIT

No authorization is required for the DISPLAY UTILITY command.

DEBUGSESSION

Grants the privilege to attach a debug client to the current application process connection, which enables client application debugging of native SQL or Java procedures that are executed within the session.

EXPLAIN

Grants the privilege to issue the following without requiring the privileges needed to execute the statement:

- EXPLAIN statement with the options:
 - PLAN
 - ALL

- PREPARE statement
- DESCRIBE TABLE statement
- Explain dynamic SQL statements that execute under the special register CURRENT EXPLAIN MODE, when CURRENT EXPLAIN MODE = EXPLAIN
- BIND options: EXPLAIN(ONLY) and SQLERROR(CHECK)

EXPLAIN(ONLY) allows to explain the statements.

SQLERROR(CHECK) performs all syntax and semantic checks on the SQL statements that are being bound.

MONITOR1

Grants the privilege to obtain IFC data classified as serviceability data, statistics, accounting, and other performance data that does not contain potentially secure data.

MONITOR2

Grants the privilege to obtain IFC data classified as containing potentially sensitive data such as SQL statement text and audit data. Users with MONITOR2 privileges have MONITOR1 privileges.

RECOVER

Grants the privilege to issue the RECOVER INDOUBT command.

SQLADM

Grants the authority to perform the following actions without requiring any additional privileges:

- DESCRIBE TABLE statement
- EXPLAIN statement with the following options:
 - PLAN
 - ALL
 - STMTCACHE ALL
 - STMTID
 - STMTTOKEN
 - MONITORED STMTS
- PREPARE statement
- Explain dynamic SQL statements that execute under the special register CURRENT EXPLAIN MODE, when CURRENT EXPLAIN MODE = EXPLAIN
- BIND options: EXPLAIN(ONLY) and SQLERROR(CHECK)

EXPLAIN(ONLY) allows to explain the statements.

SQLERROR(CHECK) performs all syntax and semantic checks on the SQL statements that are being bound.

- START DYNQUERYCAPTURE command
- START ML command
- START PROFILE command
- START TRACE command
- STOP DYNQUERYCAPTURE command
- STOP ML command
- STOP PROFILE command
- STOP TRACE command
- DISPLAY DYNQUERYCAPTURE command
- DISPLAY ML command
- DISPLAY PROFILE command
- Execute the RUNSTATS utility and the MODIFY STATISTICS utility in any database.

- MONITOR2 privilege to obtain IFC data classified as containing potentially sensitive data, such as SQL statement text and audit data, as well as IFC data classified as serviceability data, statistics, accounting, and other performance data.

STOPALL

Grants the privilege to issue the STOP DB2 command.

STOSPACE

Grants the privilege to use the STOSPACE utility.

SYSADM

Grants all Db2 privileges except for a few reserved for installation SYSADM authority. The privileges the user possesses are all grantable, including the SYSADM authority itself. The privileges the user lacks restrict what the user can do with the directory and the catalog. Using WITH GRANT OPTION when granting SYSADM is redundant but valid. For more on SYSADM and installation SYSADM authority, see [Managing administrative authorities \(Managing Security\)](#).

SYSCTRL

Grants the system control authority, which allows the user to have most of the privileges of a system administrator but excludes the privileges to read or change user data. Using WITH GRANT OPTION when granting SYSCTRL is redundant but valid. For more information on SYSCTRL authority, see [SYSCTRL \(Managing Security\)](#).

SYSOPR

Grants the privilege to have system operator authority.

TRACE

Grants the privilege to issue the MODIFY TRACE, START TRACE, and STOP TRACE commands.

ON SYSTEM

Identifies that the system privilege is granted for the entire Db2 subsystem.

TO

Refer to [“GRANT statement” on page 1963](#) for a description of the TO clause.

WITH GRANT OPTION

If you grant the SYSADM or SYSCTRL system privilege, WITH GRANT OPTION is valid but unnecessary. It is unnecessary because whoever is granted SYSADM or SYSCTRL has that authority and all the privileges it implies, with the GRANT option.

Examples for GRANT (system privileges)**Example 1**

Grant DISPLAY privileges to user LUTZ.

```
GRANT DISPLAY
TO LUTZ;
```

Example 2

Grant BSDS and RECOVER privileges to users PARKER and SETRIGHT, with the WITH GRANT OPTION.

```
GRANT BSDS,RECOVER
TO PARKER,SETRIGHT
WITH GRANT OPTION;
```

Example 3

Grant TRACE privileges to all local users.

```
GRANT TRACE
TO PUBLIC;
```

Example 4

Grant ARCHIVE privileges to role ROLE1:

```
GRANT ARCHIVE TO ROLE ROLE1;
```

Example 5

SECADM Linda grants the privilege to Steve to create a secure object:

```
GRANT CREATE_SECURE_OBJECT  
TO STEVE;
```

Example 6

Grant system DBADM with ACCESSCTRL and with DATAACCESS to role, ADMINROLE and authid, SALLY. Since GRANT system DBADM also grants ACCESSCTRL and DATAACCESS by default, WITH ACCESSCTRL and WITH DATAACCESS clauses need not be specified explicitly.

```
GRANT DBADM ON SYSTEM  
TO ROLE ADMINROLE;  
GRANT DBADM, ACCESSCTRL, DATAACCESS  
ON SYSTEM  
TO SALLY;
```

Example 7

Grant system DBADM without ACCESSCTRL and without DATAACCESS to John. The WITHOUT ACCESSCTRL and WITHOUT DATAACCESS clauses need to be specified explicitly.

```
GRANT DBADM WITHOUT ACCESSCTRL  
WITHOUT DATAACCESS  
ON SYSTEM  
TO JOHN;
```

Related tasks

[Managing explicit privileges \(Managing Security\)](#)

Related reference

[Explicit system privileges \(Managing Security\)](#)

GRANT statement (table or view privileges)

This form of the GRANT statement grants privileges on tables and views.

Syntax for GRANT (table or view privileges)

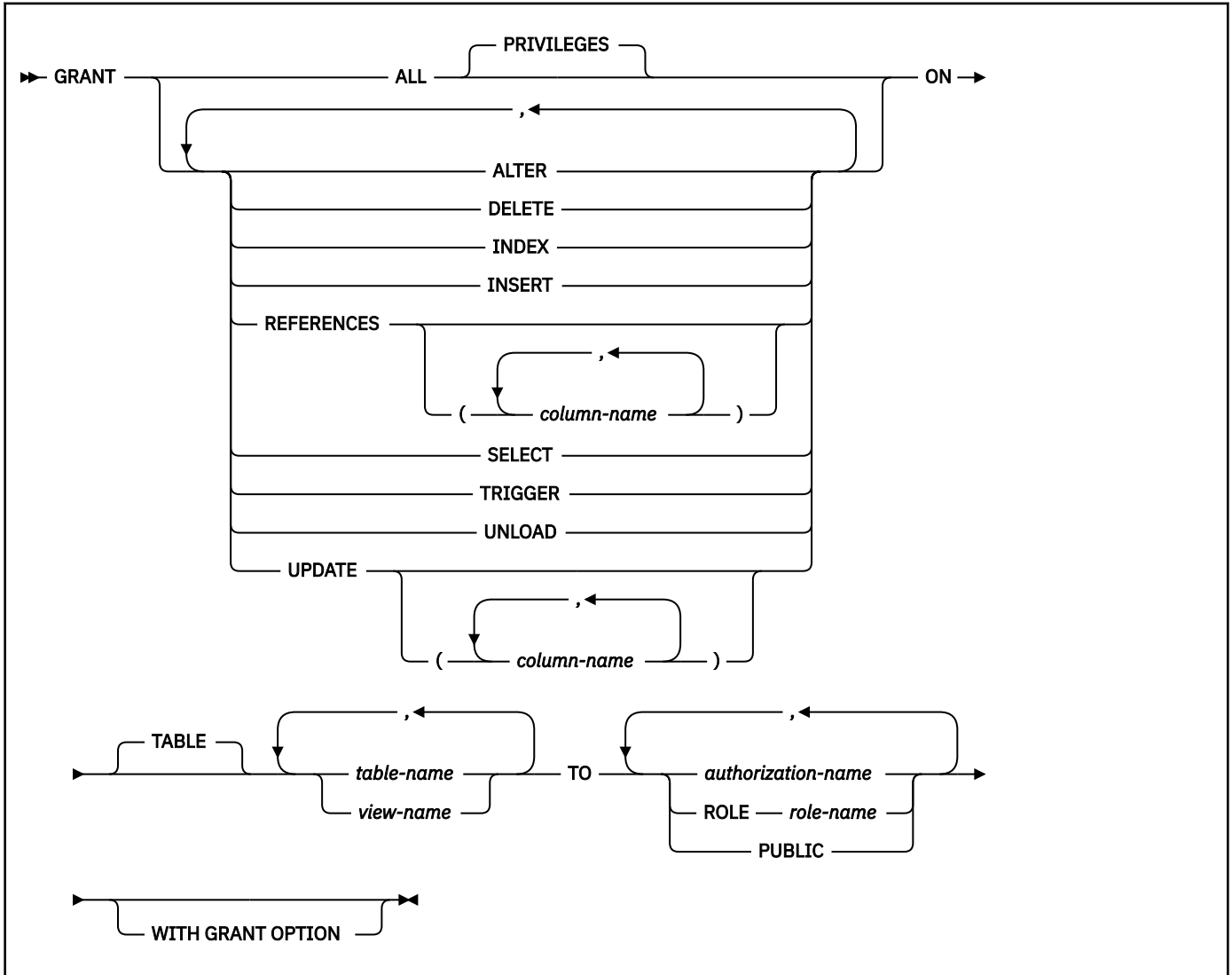

Description for GRANT (table or view privileges)

ALL or ALL PRIVILEGES

Grants all table or view privileges for which you have GRANT authority, for the tables and views named in the ON clause.

If you do not use ALL, you must use one or more of the keywords in the following list. For each keyword that you use, you must have GRANT authority for that privilege on every table or view identified in the ON clause.

ALTER

Grants the privilege to alter the specified table or create a trigger on the specified table. ALTER cannot be used if the statement identifies an auxiliary table or a view.

DELETE

Grants the privilege to delete rows in the specified table or view. DELETE cannot be granted on an auxiliary table.

INDEX

Grants the privilege to create an index on the specified table. INDEX cannot be granted on a view.

INSERT

Grants the privilege to insert rows into the specified table or view. INSERT cannot be granted on an auxiliary table.

REFERENCES

Grants the privilege to add a referential constraint in which the specified table is a parent. If a list of column names is not specified or if REFERENCES is granted via the specification of ALL PRIVILEGES, the grantee can define referential constraints using all columns of the table as a parent key, even those added later via the ALTER TABLE statement. This privilege cannot be granted on a view or auxiliary table.

REFERENCES(*column-name*,...)

Grants the privilege to add or drop a referential constraint in which the specified table is a parent using only those columns that are specified in the column list as a parent key. Each *column-name* must be an unqualified name that identifies a column of the table identified in the ON clause. This privilege cannot be granted on a view or auxiliary table.

SELECT

Grants the privilege to create a view or read data from the specified table or view. SELECT cannot be granted on an auxiliary table.

TRIGGER

Grants the privilege to create a trigger on the specified table. TRIGGER cannot be granted on an auxiliary table or a view.

UNLOAD

Grants the privilege to use the UNLOAD utility. UNLOAD cannot be granted on an auxiliary table or a view.

UPDATE

Grants the privilege to update rows in the specified table or view. UPDATE cannot be granted on an auxiliary table.

UPDATE(*column-name*,...)

Grants the privilege to update only the columns named. Each *column-name* must be the unqualified name of a column of every table or view identified in the ON clause. Each *column-name* must not identify a column of an auxiliary table.

ON *table-name* or *view-name*

Specifies the tables or views on which you are granting the privileges. The list can be a list of table names or view names, or a combination of the two. A declared temporary table and a table that is implicitly created for an XML column must not be identified.

If you use GRANT ALL, then for each named table or view, the privilege set (described in ["Authorization for GRANT" on page 1964](#) in ["GRANT statement" on page 1963](#)) must include at least one privilege with the GRANT option.

TO

Refer to ["GRANT statement" on page 1963](#) for a description of the TO clause.

WITH GRANT OPTION

Refer to ["GRANT statement" on page 1963](#) for a description of the WITH GRANT OPTION clause.

Notes for GRANT (table or view privileges)

The REFERENCES privilege does not replace the ALTER privilege. It was added to conform to the SQL standard. To define a foreign key that references a parent table, you must have either the REFERENCES or the ALTER privilege, or both.

For a created temporary table, only ALL or ALL PRIVILEGES can be granted. Specific table privileges cannot be granted. In addition, only the ALTER, DELETE, INSERT, and SELECT privileges apply to a created temporary table.

For a view of a created temporary table, either ALL or the specific UPDATE, DELETE, INSERT and SELECT privileges can be granted. When ALL is specified only the UPDATE, DELETE, INSERT, and SELECT privileges apply to a view on created temporary table. However, the UPDATE operation of the view is not allowed.

To grant table privileges on a created temporary table, the privilege set must include one of the following:

- SYSADM
- DBADM on DSNDB06
- Ownership of the created temporary table

To grant table privileges on a view of a created temporary table, the privilege set must include one of the following:

- SYSADM
- ownership of the created temporary table

For a declared temporary table, no privileges can be granted. When a declared temporary table is defined, PUBLIC implicitly receives all table privileges (without GRANT authority) for the table. These privileges are not recorded in the Db2 catalog, and they cannot be revoked.

For an auxiliary table, only the INDEX privilege can be granted. DELETE, INSERT, SELECT, and UPDATE privileges on the base table that is associated with the auxiliary table extend to the auxiliary table.

- ALTER
- INDEX
- REFERENCES
- TRIGGER

Examples for GRANT (table or view privileges)

Example 1: Grant SELECT privileges on table DSN8C10.EMP to user PULASKI.

```
GRANT SELECT ON DSN8C10.EMP TO PULASKI;
```

Example 2: Grant UPDATE privileges on columns EMPNO and WORKDEPT in table DSN8C10.EMP to all users at the current server.

```
GRANT UPDATE (EMPNO,WORKDEPT) ON TABLE DSN8C10.EMP TO PUBLIC;
```

Example 3: Grant all privileges on table DSN8C10.EMP to users KWAN and THOMPSON, with the WITH GRANT OPTION.

```
GRANT ALL ON TABLE DSN8C10.EMP TO KWAN,THOMPSON WITH GRANT OPTION;
```

Example 4: Grant the SELECT and UPDATE privileges on the table DSN8C10.DEPT to every user in the network.

```
GRANT SELECT, UPDATE ON TABLE DSN8C10.DEPT  
TO PUBLIC;
```

Even with this grant, it is possible that some network users do not have access to the table at all, or to any other object at the subsystem where the table exists. Controlling access to the subsystem involves the communications databases at the subsystems in the network. The tables for the communication databases are described in [Appendix H, “Db2 catalog tables,” on page 2333](#). Controlling access is described in [Securing Db2 \(Db2 for z/OS in IBM Documentation\)](#).

Example 5: Grant ALTER privileges on table DSN9910.EMP to role ROLE1:

```
GRANT ALTER ON TABLE DSN9910.EMP TO ROLE ROLE1;
```

GRANT statement (type or JAR file privileges)

This form of the GRANT statement grants the privilege to use distinct types, array types, or JAR files.

Syntax for GRANT (type or JAR file privileges)

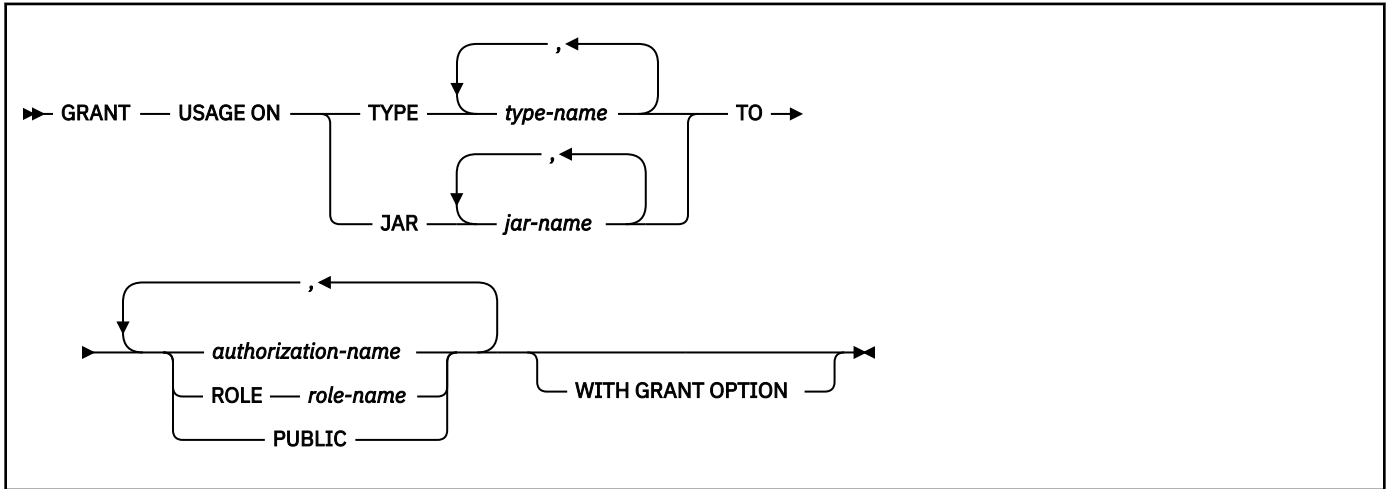

Description for GRANT (type or JAR file privileges)

USAGE

Grants the privilege to use the distinct type in tables, functions procedures, or the privilege to use the JAR file.

TYPE *type-name*

Identifies the user-defined type. The name, including the implicit or explicit schema name, must identify a unique user-defined type that exists at the current server.

JAR *jar-name*

Identifies the JAR file. The name, including the implicit or explicit schema name, must identify a unique JAR file that exists at the current server.

TO

Refer to “GRANT statement” on page 1963 for a description of the TO clause.

WITH GRANT OPTION

Refer to “GRANT statement” on page 1963 for a description of the WITH GRANT OPTION clause.

Notes for GRANT (type or JAR file privileges)

Alternative syntax and synonyms: To provide compatibility with previous releases of Db2 or other products in the Db2 family, Db2 supports DATA TYPE or DISTINCT TYPE as a synonym for TYPE.

Examples for GRANT (type or JAR file privileges)

Example 1: Grant the USAGE privilege on distinct type SHOE_SIZE to user JONES. This GRANT statement does not give JONES the privilege to execute the cast functions that are associated with the distinct type SHOE_SIZE.

```
GRANT USAGE ON TYPE SHOE_SIZE TO JONES;
```

Example 2: Grant the USAGE privilege on distinct type US_DOLLAR to all users at the current server.

```
GRANT USAGE ON TYPE US_DOLLAR TO PUBLIC;
```

Example 3: Grant the USAGE privilege on distinct type CANADIAN_DOLLAR to the administrative assistant (ADMIN_A), and give this user the ability to grant the USAGE privilege on the distinct type to others. The administrative assistant cannot grant the privilege to execute the cast functions that are associated with

the distinct type CANADIAN_DOLLAR because WITH GRANT OPTION does not give the administrative assistant the EXECUTE authority on these cast functions.

```
GRANT USAGE ON TYPE CANADIAN_DOLLAR TO ADMIN_A  
WITH GRANT OPTION;
```

Example 4: Grant the USAGE privilege on the distinct type MILES to role ROLE1 at the current server:

```
GRANT USAGE ON TYPE MILES  
TO ROLE ROLE1;
```

GRANT statement (variable privileges)

This form of the GRANT statement grants privileges on global variables.

Syntax for GRANT (variable privileges)

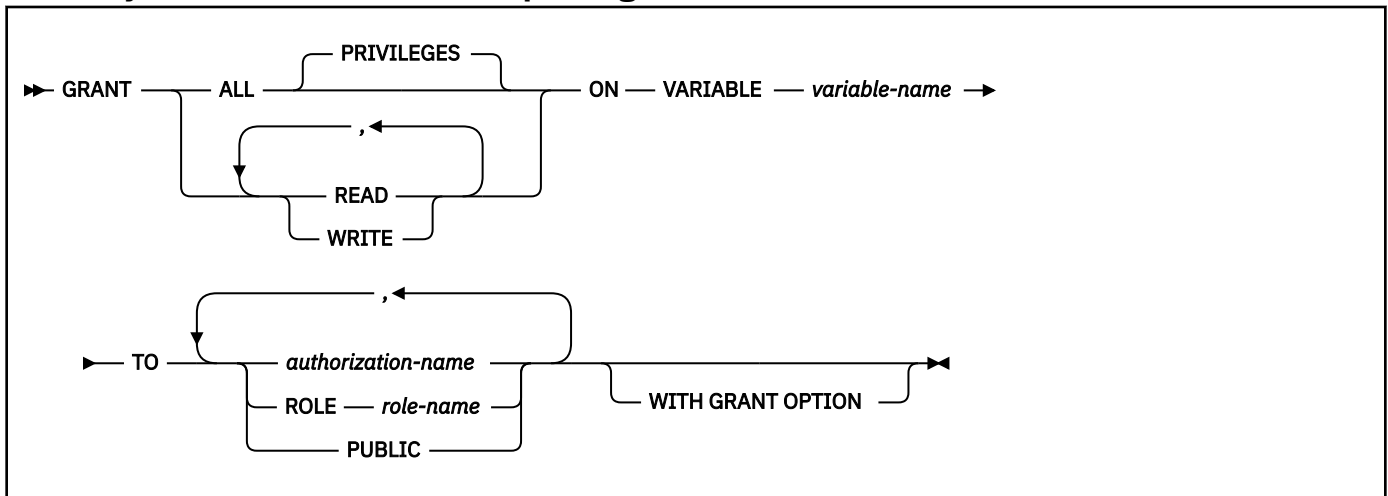

Description for GRANT (variable privileges)

ALL PRIVILEGES

Grants both READ and WRITE privileges on the specified global variable.

READ

Grants the privilege to access the content of the specified global variable.

WRITE

Grants the privilege to modify the content of the specified global variable.

ON VARIABLE *variable-name*

Identifies the global variable for which you are granting privileges. *variable-name*, including an implicit or explicit qualifier, must identify a global variable that exists at the current server.

TO

Refer to “GRANT statement” on page 1963 for a description of the TO clause.

WITH GRANT OPTION

Refer to “GRANT statement” on page 1963 for a description of the WITH GRANT OPTION clause.

Examples for GRANT (variable privileges)

Example 1: Grant the read privilege on the ACCOUNTNO variable on the current server to user Jones:

```
GRANT READ ON VARIABLE ACCOUNTNO TO JONES;
```

GRANT statement (use privileges)

This form of the GRANT statement grants authority to use particular buffer pools, storage groups, or table spaces.

Syntax for GRANT (use privileges)

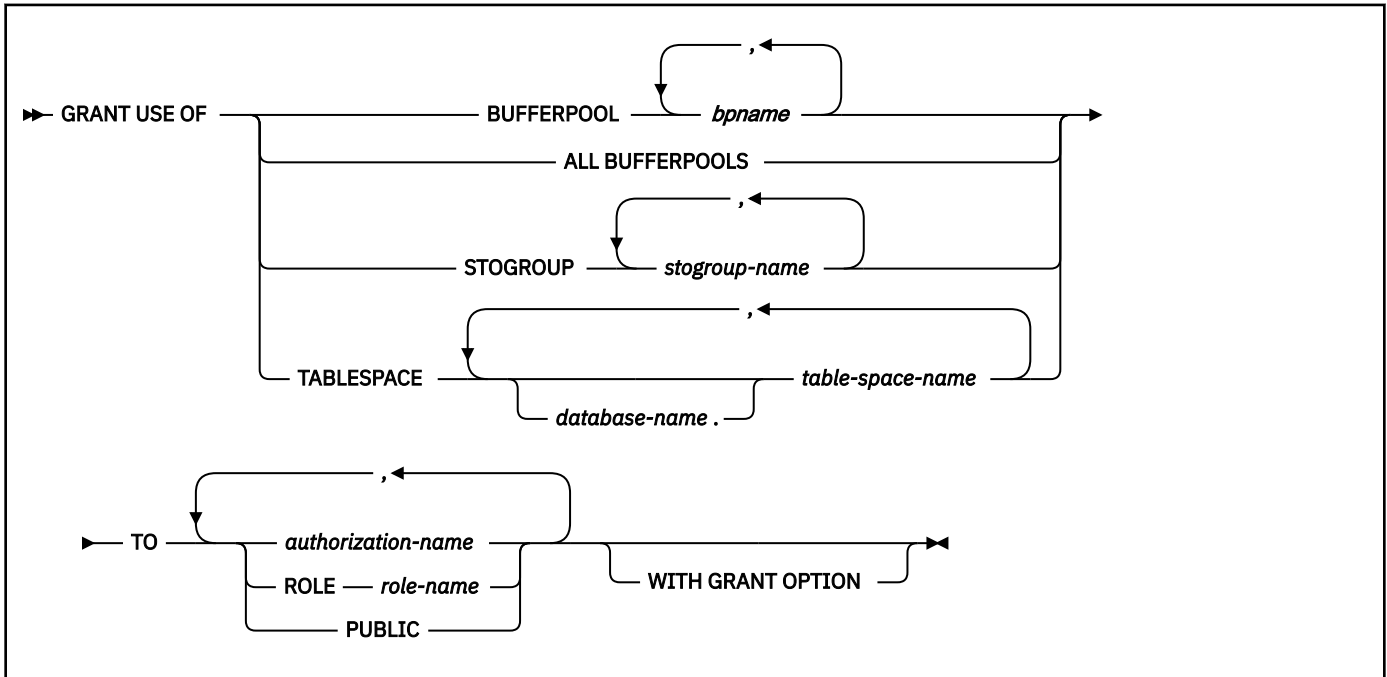

Description for GRANT (use privileges)

BUFFERPOOL *bpname*,...

Grants the privilege to refer to any of the identified buffer pools in a CREATE INDEX, CREATE TABLESPACE, ALTER INDEX, or ALTER TABLESPACE statement. See [“Naming conventions in SQL”](#) on page 79 for more details about *bpname*.

ALL BUFFERPOOLS

Grants the privilege to refer to any buffer pool in a CREATE INDEX, CREATE TABLESPACE, ALTER INDEX, or ALTER TABLESPACE statement.

STOGROUP *stogroup-name*,...

Grants the privilege to refer to any of the identified storage groups in a CREATE INDEX, CREATE TABLESPACE, ALTER INDEX, or ALTER TABLESPACE statement.

TABLESPACE *database-name.table-space-name*,...

Grants the privilege to refer to any of the identified table spaces in a CREATE TABLE statement. The default for *database-name* is DSNDB04.

You cannot grant the privilege for table spaces that are for declared temporary tables (table spaces in a work file database). For these table spaces, PUBLIC implicitly has the TABLESPACE privilege (without GRANT authority); this privilege is not recorded in the Db2 catalog, and it cannot be revoked.

TO

Refer to [“GRANT statement”](#) on page 1963 for a description of the TO clause.

WITH GRANT OPTION

Refer to [“GRANT statement”](#) on page 1963 for a description of the WITH GRANT OPTION clause.

Notes for GRANT (use privileges)

You can grant privileges for only one type of object with each statement. Thus, you can grant the use of several table spaces with one statement, but not the use of a table space and a storage group. For each object you identify, you must have the USE privilege with GRANT authority.

Examples for GRANT (use privileges)

Example 1: Grant authority to use buffer pools BP1 and BP2 to user MARINO.

```
GRANT USE OF BUFFERPOOL BP1,BP2
TO MARINO;
```

Example 2: Grant to all local users the authority to use table space DSN8S12D in database DSN8D12A.

```
GRANT USE OF TABLESPACE
DSN8D12A.DSN8S12D
TO PUBLIC;
```

Example 3: Grant authority to use storage group SG1 to role ROLE1:

```
GRANT USE OF STOGROUP SG1
TO ROLE ROLE1;
```

HOLD LOCATOR statement

The HOLD LOCATOR statement allows a LOB locator variable to retain its association with a value beyond a unit of work.

Invocation for HOLD LOCATOR

This statement can only be embedded in an application program. It cannot be issued interactively. It is an executable statement that can be dynamically prepared. However, the EXECUTE statement with the USING clause must be used to execute the prepared statement. HOLD LOCATOR cannot be used with the EXECUTE IMMEDIATE statement.

Authorization for HOLD LOCATOR

None required.

Syntax for HOLD LOCATOR

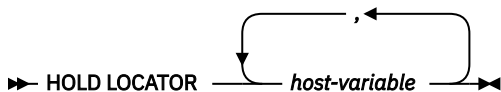

Description for HOLD LOCATOR

host-variable, ...

Identifies one or more locator variables that must be declared in accordance with the rules for declaring locator variables. The locator variable type must be a binary large object locator, a character large object locator, or a double-byte character large object locator.

The *host-variable* must currently have a locator assigned to it. That is, a locator must have been assigned during this unit of work (by a FETCH, SELECT INTO, assignment statement, SET *host-variable* statement, or VALUES INTO statement); otherwise, an error is returned.

If more than one locator is specified and an error is returned on one of the locators, it is possible that some locators have been held and others have not been held.

Notes for HOLD LOCATOR

A host-variable LOB locator variable that has the hold property is freed (has its association between it and its value removed) when:

- The SQL FREE LOCATOR statement is executed for the locator variable.
- The SQL ROLLBACK statement is executed.
- The SQL session is terminated.

Example for HOLD LOCATOR

Assume that the employee table contains columns RESUME, HISTORY, and PICTURE and that locators have been established in a program to represent the values represented by the columns. Give the CLOB locator variables LOCRES and LOCHIST, and the BLOB locator variable LOCPIC the hold property.

```
EXEC SQL HOLD LOCATOR :LOCRES, :LOCHIST, :LOCPIC
```

INCLUDE statement

The INCLUDE statement inserts application code, including declarations and statements, into a source program.

Invocation for INCLUDE

This statement can only be embedded in an application program. It is not an executable statement. It must not be specified in Java or REXX.

Authorization for INCLUDE

None required.

Syntax for INCLUDE

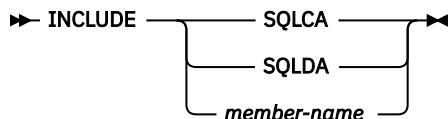

Description for INCLUDE

SQLCA

Indicates that the description of an SQL communication area (SQLCA) is to be included. INCLUDE SQLCA must not be specified more than once in the same application program. In COBOL, INCLUDE SQLCA must be specified in the Working-Storage Section or the Linkage Section. INCLUDE SQLCA must not be specified if the program is prepared (either with the Db2 precompiler or coprocessor) with the STDSQL(YES) SQL processing option.

For a description of the SQLCA, see [Appendix F, “SQL communication area \(SQLCA\),”](#) on page 2303.

SQLDA

Indicates that the description of an SQL descriptor area (SQLDA) is to be included. It must not be specified in a Fortran. For a description of the SQLDA, see [Appendix G, “SQL descriptor area \(SQLDA\),”](#) on page 2313.

member-name

Names a member of the partitioned data set to be the library input when your application program is prepared (either with the Db2 precompiler or coprocessor). It must be an SQL identifier.

The member can contain any host language source statements and any SQL statements other than an INCLUDE statement. In COBOL, INCLUDE *member-name* must not be specified in other than the Data Division or the Procedure Division.

Notes for INCLUDE

When your application program is prepared (either with the Db2 precompiler or coprocessor), the INCLUDE statement is replaced by source statements. Thus, the INCLUDE statement must be specified at a point in your application program where the resulting source statements are acceptable to the compiler.

The INCLUDE statement cannot refer to source statements that themselves contain INCLUDE statements.

The declarations that are generated by DCLGEN can be used in an application program by specifying the same member in the INCLUDE statement as in the DCLGEN LIBRARY parameter.

Example for INCLUDE

Include an SQL communications area in a PL/I program.

```
EXEC SQL INCLUDE SQLCA;
```

INSERT statement

The INSERT statement inserts rows into a table or view. Inserting a row into a view inserts the row into the table on which the view is based if no INSTEAD OF INSERT trigger is defined for this view. If such a trigger is defined, the trigger is activated instead.

The table or view can be at the current server or any Db2 subsystem with which the current server can establish a connection.

The INSERT statement has the following three forms:

VALUES form

The *VALUES form* of the INSERT statement inserts a single row into the table or view using the values provided or referenced.

fullselect form

The *fullselect form* of the INSERT statement inserts one or more rows into the table or view using values from other tables, or views, or both.

FOR *n* ROWS form

The *FOR n ROWS form* of the INSERT statement inserts multiple rows into the table or view using values provided or referenced. Although not required, the values can come from host-variable arrays.

This form of INSERT is supported in SQL procedure applications. However, because host-variable arrays are not supported in SQL procedure applications, the support is limited to insertion of scalar values.

Invocation for INSERT

This statement can be embedded in an application program or issued interactively. It is an executable statement that can be dynamically prepared.

Authorization for INSERT

Authority requirements depend on whether the object identified in the statement is a user-defined table, a catalog table for which inserts are allowed, or a view:

When a user-defined table is identified: The privilege set must include at least one of the following:

- The INSERT privilege on the table
- Ownership of the table
- DBADM authority on the database that contains the table
- SYSADM authority
- DATAACCESS authority

If the database is implicitly created, the database privileges must be on the implicit database or on DSNDB04.

When a catalog table is identified: The privilege set must include at least one of the following:

- ACCESSCTRL authority
- DATAACCESS authority
- DBADM authority on the catalog database
- Installation SYSOPR authority
- SQLADM authority
- SYSCTRL authority
- SYSADM authority
- System DBADM authority

When a view is identified: The privilege set must include at least one of the following:

- DATAACCESS authority
- INSERT privilege on the view
- SYSADM authority

The owner of a view, unlike the owner of a table, might not have INSERT authority on the view (or can have INSERT authority without being able to grant it to others). The nature of the view itself can preclude its use for INSERT. For more information, see the discussion of authority in [“CREATE VIEW statement” on page 1812](#).

If the INSERT statement is embedded in a SELECT statement, the privilege set must include the SELECT privilege on the table or view.

If a fullselect is specified, the privilege set must include authority to execute the fullselect. For more information about the authorization rules, see [“Authorization for queries” on page 1007](#).

If the statement is embedded in an application program, the privilege set is the privileges that are held by the owner of the plan or package. If the statement is dynamically prepared, the privilege set is determined by the DYNAMICRULES behavior in effect (run, bind, define, or invoke) and is summarized in [Table 171 on page 1089](#). (For more information on these behaviors, including a list of the DYNAMICRULES bind option values that determine them, see [“Authorization IDs and dynamic SQL” on page 94](#).)

Syntax for INSERT

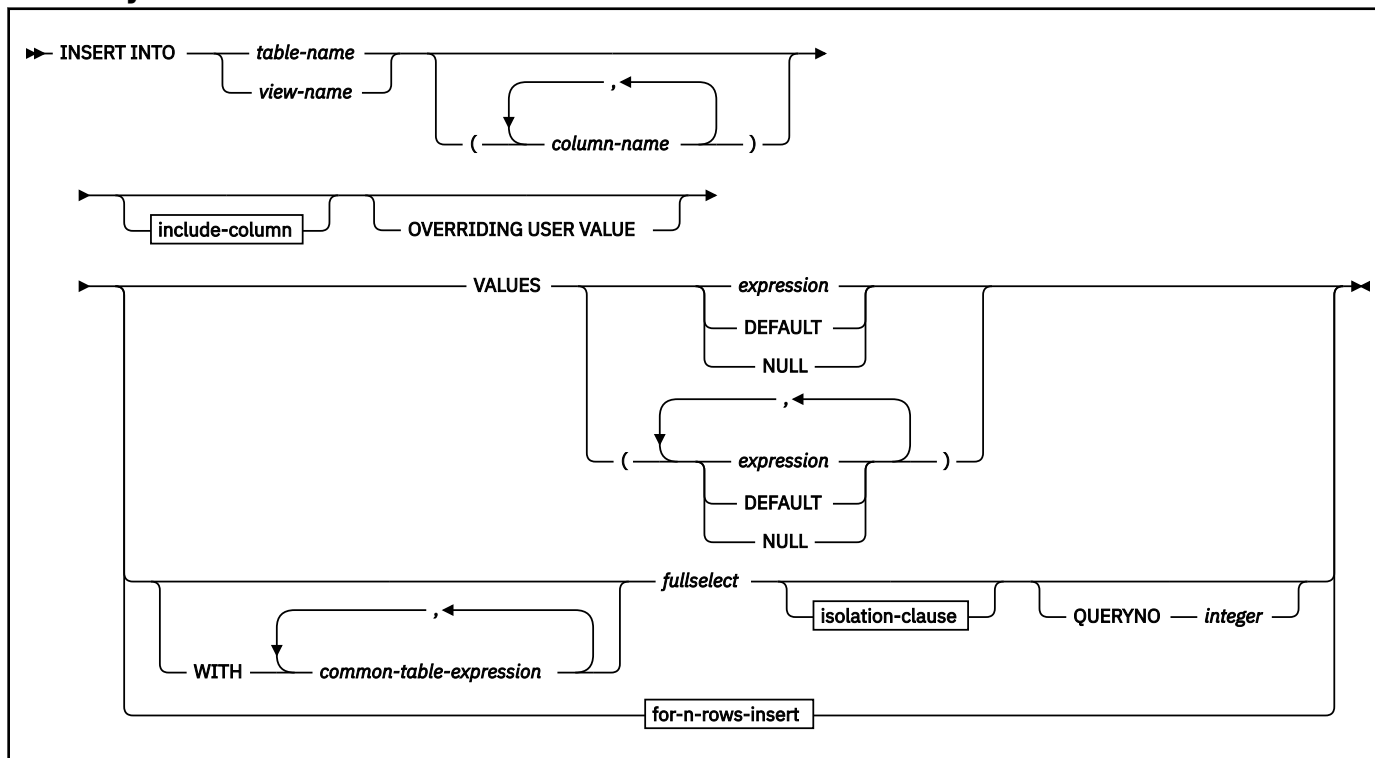

include-column:

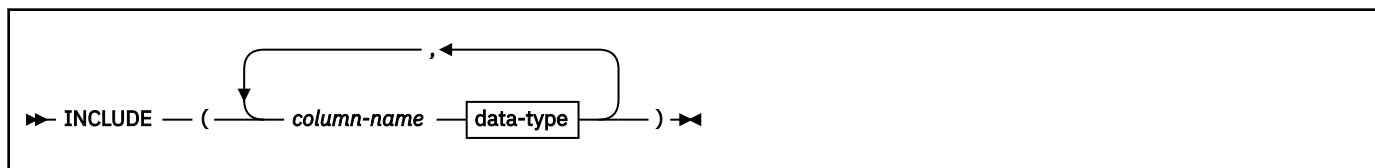

data-type:



built-in-type:

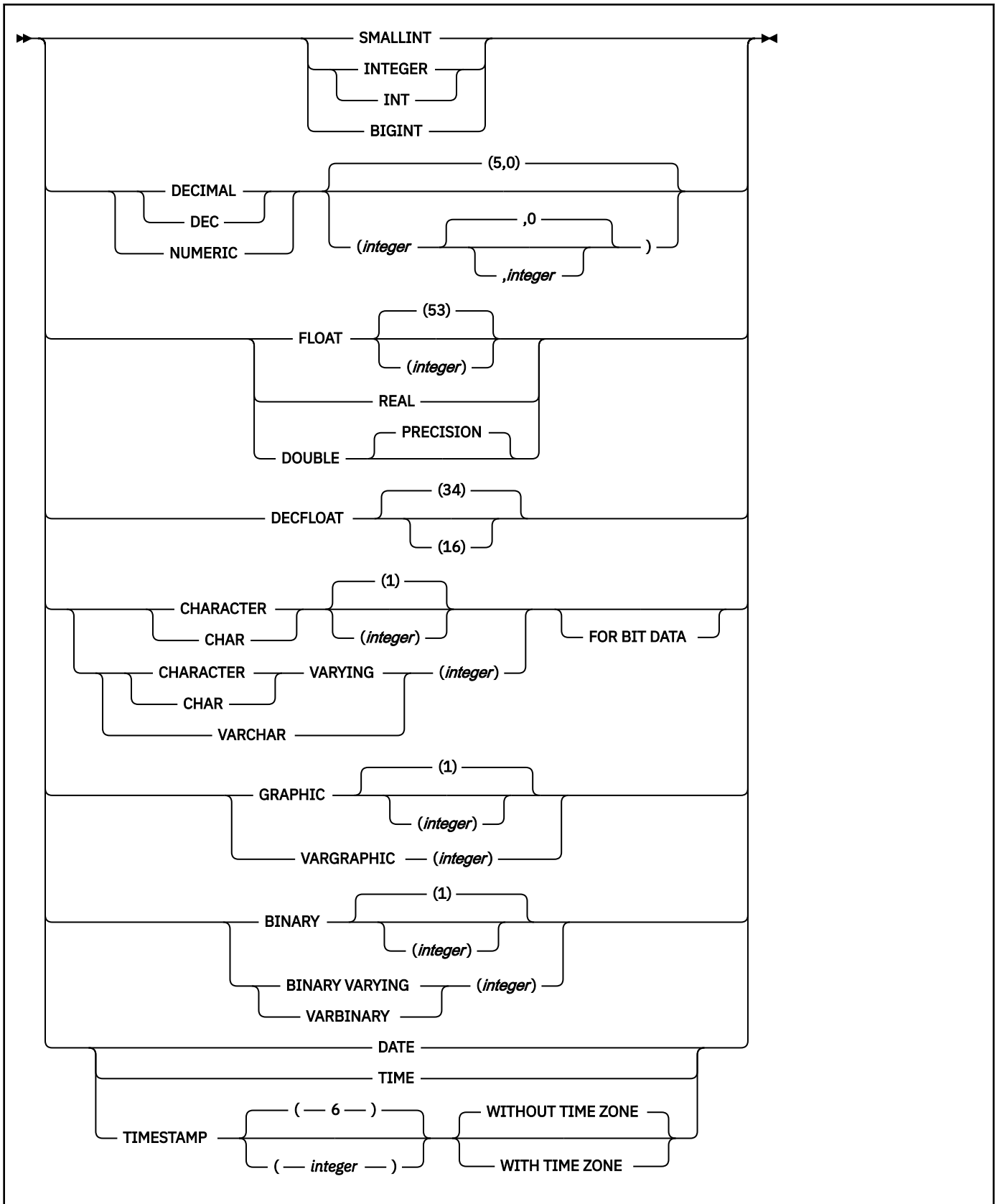

isolation-clause:

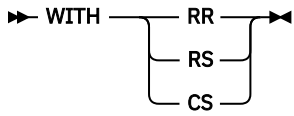

for-n-rows-insert:

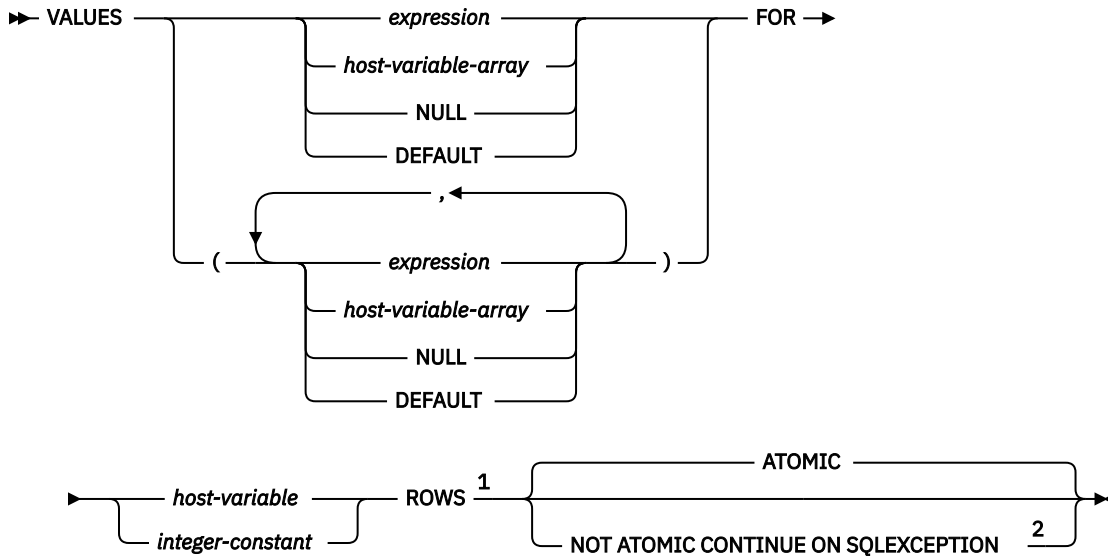

Notes:

¹ The FOR *n* ROWS clause must be specified for this form of a static INSERT statement. However, this clause is optional for a dynamic INSERT statement. For a dynamic statement, the FOR *n* ROWS clause can be specified on the EXECUTE statement.

² The ATOMIC or NOT ATOMIC CONTINUE ON SQLEXCEPTION clauses can be specified for a static multiple-row-insert. However, this clause must not be specified for a dynamic INSERT statement. For a dynamic statement, the ATOMIC or NOT ATOMIC CONTINUE ON SQLEXCEPTION clause is specified as an attribute on the PREPARE statement.

Description for INSERT

INTO *table-name* or *view-name*

Identifies the object of the INSERT statement. The name must identify a table or view that exists at the current server. The name must not identify:

- An auxiliary table
- A catalog table
- A directory table
- A read-only view unless an instead of trigger is defined for the insert operation on the view. (For a description of a read-only view, see “CREATE VIEW statement” on page 1812.)
- A view column that is derived from a constant, expression, or scalar function
- A view column that is derived from the base table column as some other column of the view
- A materialized query table
- A table that is implicitly created for an XML column

In an IMS or CICS application, the Db2 subsystem that contains the identified table or view must be a remote server that supports two-phase commit.

column-name,...

Specifies the columns for which insert values are provided. Each name must identify a column of the table or view. The columns can be identified in any order, but the same column must not be identified more than one time. If extended indicators are not enabled, a view column that cannot accept insert values must not be identified. If extended indicators are not enabled, and the object of the INSERT statement is a view with columns that cannot accept insert values, a list of column names must be specified, and the list must not identify those columns. If a qualifier is specified, it must be valid (that is, the table name must be the table or view name specified after the INTO keyword, and if a qualifier is specified for the table name, it must match the default qualifier).

Omission of the column list is an implicit specification of a list in which every column of the table (that is not defined as implicitly hidden) or view is identified in left-to-right order. This list is established when the statement is prepared and therefore does not include columns that were added to the table after the statement was prepared.

The effect of a rebind on INSERT statements that do not include a column list is that the implicit list of names is re-established. Therefore, the number of column values that an INSERT statement must specify can change, resulting in an error when the statement is rebound. For this reason, it is best to always specify the column names in INSERT statements.

include-column

Specifies a set of columns that are included, along with the columns of *table-name* or *view-name*, in the result table of the INSERT statement when it is nested in the FROM clause of the outer fullselect that is used in a subselect, a SELECT statement, or in a SELECT INTO statement. The included columns are appended to the end of the list of columns that is identified by *table-name* or *view-name*.

INCLUDE

Introduces a list of columns that is to be included in the result table of the INSERT statement. The included columns are only available if the INSERT statement is nested in the FROM clause of a SELECT statement or a SELECT INTO statement.

column-name

Specifies the name for a column of the result table of the INSERT statement that is not the same name as another included column nor a column in the table or view that is specified in *table-name* or *view-name*.

data-type

Specifies the data type of the included column. The included columns are nullable.

built-in-type

Specifies a built-in data type. See [“CREATE TABLE statement”](#) on page 1650 for a description of each built-in type.

The CCSID 1208 and CCSID 1200 clauses must not be specified for an INCLUDE column.

distinct-type

Specifies a distinct type. Any length, precision, or scale attributes for the column are those of the source type of the distinct type as specified by using the CREATE TYPE statement.

OVERRIDING USER VALUE

Specifies that the value specified in the VALUES clause or produced by a fullselect for a column that is defined as either GENERATED ALWAYS or GENERATED BY DEFAULT is ignored. Instead, a system-generated value is inserted, overriding the user-specified value.

If OVERRIDING USER VALUE is specified, the implicit or explicit list of column must include a column that is defined as either GENERATED ALWAYS or GENERATED BY DEFAULT. For example, a ROWID column, an identity column, or a row change timestamp column.

VALUES form descriptions

The following descriptions apply to the VALUES form of INSERT.

VALUES

Specifies one new row in the form of a list of values. The number of values in the VALUES clause must be equal to the number of names in the column list and the columns that are identified in the INCLUDE clause. The first value is inserted in the first column in the list, the second value in the

second column, and so on. If more than one value is specified, the list of values must be enclosed in parentheses. Assignments to included columns are only processed when the INSERT statement is nested in the FROM clause in a SELECT statement or a SELECT INTO statement.

expression

Any expression of the type described in [“Expressions” on page 245](#). The expression must not include a column name. If *expression* is a host variable, the host variable can identify a structure. Any host variable or structure that is specified must be described in the application program according to the rules for declaring host structures and variables.

If *expression* is a host variable, it can include an indicator variable or an indicator array (in the case of a host structure).

If extended indicators are enabled, and the expression is not a single variable, the extended indicator values of DEFAULT (-5) and UNASSIGNED (-7) must not be used for that expression.

In addition:

- A CAST specification can be used if either of the following is true:
 - The target column is defined as nullable.
 - The target column is defined as NOT NULL with a non-null default, the source of the CAST specification is a single host variable, and the data attributes (data type, length, precision, and scale) of the host variable are the same as the result of the cast specification.
- A scalar fullselect can be used if either of the following is true for each expression in the select list of the fullselect:
 - The target column that corresponds to the expression is defined as nullable.
 - The expression is not more complex than a reference to a single host variable for which the indicator is set to an extended indicator value of DEFAULT (-5) or UNASSIGNED (-7), or the expression is a CAST specification which would have been valid as a stand-alone expression.

DEFAULT

Specifies the default value for the column. If the column is a generated column, Db2 will generate a value for the column.

For information on default values of data types, see the description of the DEFAULT clause for [“CREATE TABLE statement” on page 1650](#).

NULL

Specifies the null value as the value of the column. Specify NULL only for nullable columns.

If the implicit or explicit list of columns includes a ROWID, an identity column, or a row change timestamp column that was defined as GENERATED ALWAYS, you must specify DEFAULT unless you specify the OVERRIDING USER VALUE clause to indicate that any user-specified value will be ignored and a unique system-generated value will be inserted.

For a ROWID or identity column that is defined as GENERATED BY DEFAULT, you can specify a value. However, a value can be inserted into ROWID column defined BY DEFAULT only if a single-column unique index is defined on the ROWID column and the specified value is a valid row ID value that was previously generated by Db2. When a value is inserted into an identity column defined BY DEFAULT, Db2 does not verify that the specified value is a unique value for the column unless the identity column has a single-column unique index.

Although an implicitly hidden DOCID column for XML values is defined as GENERATED ALWAYS, you can include the DOCID column in the explicit list of columns and specify a value for it. However, Db2 will ignore the value.

fullselect form descriptions

The following descriptions apply to the *fullselect* form of INSERT.

WITH common-table-expression

Specifies a common table expression. For an explanation of common table expression, see [“common-table-expression” on page 1069](#).

fullselect

Specifies a set of new rows in the form of the result table of a fullselect. If the result table is empty, SQLCODE is set to +100, and SQLSTATE is set to '02000'.

The base object of the INSERT statement and the base object of the fullselect or any subquery of the fullselect can be the same table. In this case, the fullselect is evaluated completely before any rows are inserted.

For an explanation of fullselect, see [“fullselect” on page 1060](#).

The number of columns in the result table must be equal to the number of names in the column list and the columns that are identified in the INCLUDE clause. The value of the first column of the result is inserted in the first column in the list, the second value in the second column, and so on. Any values that are produced for a generated column must conform to the rules that are described for those columns under the VALUES clause. Assignments to included columns are only processed when the INSERT statement is nested in the FROM clause of a SELECT statement or a SELECT INTO statement.

If the expression that specifies the value of a result column is a variable, the host variable can include an indicator variable. When extended indicator variables are enabled, the target column that corresponds to an expression in the select list of the fullselect that involves a host variable with an extended indicator value of DEFAULT (-5) or UNASSIGNED (-7), must be defined as nullable and either of the following expressions:

- The expression must not be more complex than a reference to a single host variable.
- The expression must be a CAST specification with the following characteristics:
 - The source of the CAST specification must be a single host variable.
 - The data attributes (data type, length, precision, and scale) of the host variable are the same as the result of the cast specification.

If the object table is self-referencing, the fullselect must not return more than one row.

isolation-clause

Specifies the isolation level that is used when the fullselect is executed.

WITH

Introduces the isolation level, which can be one of the following values:

RR

Repeatable read

RS

Read stability

CS

Cursor stability

The default isolation level of the statement is the isolation level of the package or plan in which the statement is bound, with the package isolation taking precedence over the plan isolation. When a package isolation is not specified, the plan isolation is the default.

QUERYNO integer

Specifies the number to be used for this SQL statement in EXPLAIN output and trace records. The number is used for the QUERYNO column of the plan table for the rows that contain information about this SQL statement. This number is also used in the QUERYNO column of the SYSIBM.SYSSTMT and SYSIBM.SYSPACKSTMT catalog tables.

If the clause is omitted, the number that is associated with the SQL statement is the statement number that is assigned during precompilation. Thus, if the application program is changed and then precompiled, that statement number might change.

Using the QUERYNO clause to assign unique numbers to the SQL statements in a program is helpful:

- For simplifying the use of optimization hints for access path selection
- For correlating SQL statement text with EXPLAIN output in the plan table

For more information about enabling and using optimization hints, see [Influencing access path selection \(Db2 Performance\)](#)

For information on accessing the plan table, see [Investigating SQL performance by using EXPLAIN \(Db2 Performance\)](#).

FOR *n* ROWS form descriptions

The following descriptions apply to the FOR *n* ROWS form of the INSERT.

VALUES

Specifies the items for the rows to be inserted. The number of items in the VALUES clause must equal the number of names in the implicit or explicit column list. The first item in the list provides the value (or values) for the first column in the list. The second item in the list provides the value (or values) for the second column, and so on.

expression

Any expression of the type described in [“Expressions” on page 245](#). The expression must not include a column name. For each row that is inserted, the corresponding column is assigned the value of the expression.

host-variable-array

Each host-variable array must be defined in the application program in accordance with the rules for declaring an array. A host-variable array contains the data for a column of table that is a target of the INSERT. The number of rows to be inserted must be less than or equal to the dimension of each of the host-variable arrays.

An optional indicator array can be specified for each host-variable array. It should be specified if the SQLTYPE of any SQLVAR occurrence indicates that the SQLVAR is nullable. The indicators must be small integers. The indicator array must be large enough to contain an indicator for each row of input data.

If extended indicator variables are enabled, the extended indicator variable values of DEFAULT or UNASSIGNED can be used inside the indicator array.

host-variable-array is supported in C/C++, COBOL, and PL/I. For more information, see [“Host-variable arrays in PL/I, C, C++, and COBOL” on page 236](#).

DEFAULT

Specifies the default value for the column. If the column is a generated column, Db2 will generate a value for the column.

For information on default values of data types, see the description of the DEFAULT clause for [“CREATE TABLE statement” on page 1650](#).

NULL

Specifies the null value as the value of the column in each row inserted. For each row inserted, the corresponding column is assigned the NULL value. Specify NULL only for nullable columns.

FOR *n* ROWS

Specifies the number of rows to be inserted, where *n* is *host-variable* or *integer-constant*. For a dynamic INSERT statement, this clause can be specified on the EXECUTE statement. For more information, see [“EXECUTE statement” on page 1909](#). However, this clause is required when a dynamic SELECT statement contains more than one multiple-row INSERT statement.

host-variable or *integer-constant* is assigned to an integral value *k*. If *host-variable* is specified, it must be an exact numeric type with scale zero, and must not include an indicator variable.

Furthermore, k must be in the range, $0 < k \leq 32767$. k rows are inserted into the target table from the specified source data.

If the statement runs on accelerator, FOR *integer-constant* ROWS is supported only if the VALUES clause uses a host variable array.

If a parameter marker is specified in this clause, a value must be provided with the USING clause of the associated EXECUTE or OPEN statement.

ATOMIC or NOT ATOMIC CONTINUE ON SQLEXCEPTION

Specifies whether all of the rows should be inserted as an atomic operation or not.

ATOMIC

Specifies that if the insert for any row fails, all changes made to the database by any of the inserts, including changes made by successful inserts, are undone. This is the default.

NOT ATOMIC CONTINUE ON SQLEXCEPTION

Specifies that, regardless of the failure of any particular insert of a row, the INSERT statement will not undo any changes made to the database by the successful inserts of other rows, and inserting will be attempted for subsequent rows. However, the minimum level of atomicity is at least that of a single insert (that is, it is not possible for a partial insert to complete), including any triggers that might have been executed as a result of the INSERT statement.

This clause is only valid for a static INSERT statement. This clause must also not be specified if the INSERT statement is contained within a SELECT statement. For a dynamic INSERT statement, specify the clause on the PREPARE statement. For more information, see [“PREPARE statement” on page 2042](#).

Notes for INSERT

Insert rules:

Insert values must satisfy the following rules. If they do not, or if any other errors occur during the execution of the INSERT statement, no rows are inserted and the position of the cursors are not changed.

- *Default values.* The value inserted in any column that is not in the column list is the default value of the column. Columns without a default value must be included in the column list. Similarly, if you insert into a view, the default value is inserted into any column of the base table that is not included in the view. Hence, all columns of the base table that are not in the view must have a default value.
- *Length.* If the insert value of a column is a number, the column must be a numeric column with the capacity to represent the integral part of the number. If the insert value of a column is a string, the column must be either a string column with a length attribute at least as great as the length of the string, or a datetime column if the string represents a date, time, or timestamp.
- *Assignment.* Insert values are assigned to columns in accordance with the assignment rules described in [Chapter 2, “Language elements in SQL,” on page 75](#).
- *Uniqueness constraints.* If the identified table or the base table of the identified view has one or more unique indexes, each row inserted into the table must conform to the constraints imposed by those indexes.
- *Referential constraints.* Each non-null insert value of a foreign key must be equal to some value of the parent key of the parent table in the relationship.
- *Check constraints.* The identified table or the base table of the identified view might have one or more check constraints. Each row inserted must conform to the conditions imposed by those constraints. Thus, each check condition must be true or unknown.
- *Field and validation procedures.* If the identified table or the base table of the identified view has a field or validation procedure, each row inserted must conform to the constraints imposed by that procedure.
- *Indexes with VARBINARY columns.* If the identified table has an index on a VARBINARY column or a column that is a distinct type that is based on VARBINARY data type, that index column cannot

specify the DESC attribute. To use the SQL data change operation on the identified table, either drop the index or alter the data type of the column to BINARY and then rebuild the index.

- *Views and the WITH CHECK OPTION.* For views defined with WITH CHECK OPTION, each row you insert into the view must conform to the definition of the view. If the view you name is dependent on other views whose definitions include WITH CHECK OPTION, the inserted rows must also conform to the definitions of those views. For an explanation of the rules governing this situation, see [“CREATE VIEW statement” on page 1812.](#)

For views that are not defined with WITH CHECK OPTION, you can insert rows that do not conform to the definition of the view. Those rows cannot appear in the view but are inserted into the base table of the view.

- *Omitting the column list.* When you omit the column list, you must specify a value for every column that was present in the table when the INSERT statement was bound or (for dynamic execution) prepared.
- *Triggers.* An INSERT statement might cause triggers to be activated. A trigger might cause other statements to be executed or raise error conditions based on the insert values. If an INSERT statement for a view activates an INSTEAD OF trigger, the validity, referential integrity, and check constraints are checked against the data changes that are performed in the trigger, and not against the definition of the view that activates the trigger or the definition of the underlying tables or views.

When triggers are processed for an INSERT statement that inserts multiple rows depends on the atomicity option that is in effect for the INSERT statement:

- **ATOMIC.** The inserts are processed as a single statement. Any statement level triggers are activated one time for the statement, and the transition tables will include all of the rows that were inserted.
- **NOT ATOMIC CONTINUE ON SQLEXCEPTION.** The inserts are processed separately. Any statement level triggers are processed for each row that is inserted, and the transition table includes the individual row that is inserted. When errors are encountered with this option in effect, processing continues, and some of the specified rows will not be inserted. In this case, if an insert trigger is defined on the underlying base table, the statement level triggers will only be activated for rows that were successfully inserted.

Regardless of the failure of any particular source row, the INSERT statement will not undo any changes that are made to the database by the statement. Insert will be attempted for rows that follow the failed row. However, the minimum level of atomicity is at least that of a single source row (that is, it is not possible for a partial insert operation to complete), including any triggers that might have been activated as a result of the INSERT statement.

Inserting XML documents:

When XML documents are inserted into a table that contains an XML index, the XML values that are inserted into the index are cast to the data type that is specified on the CREATE INDEX statement. If the XML value cannot be cast to the specified data type, the XML value is ignored for the XML index but the document is still inserted into the table. If the data type that is specified for casting is DECFLOAT, values can be rounded when they are inserted into the index. If the index is unique, the rounding that happens during the cast can result in duplicate values.

Number of rows inserted:

Normally, after an INSERT statement completes execution, the value of SQLERRD(3) in the SQLCA is the number of rows inserted. The value in SQLERRD(3) does not include the number of rows that were inserted as the result of a trigger.

For a complete description of the SQLCA, including exceptions to the above statement, see [Appendix F, “SQL communication area \(SQLCA\),” on page 2303.](#)

Nesting user-defined functions or stored procedures:

An INSERT statement can implicitly or explicitly refer to user-defined functions or stored procedures. This is known as *nesting* of SQL statements. A user-defined function or stored procedure that is nested within the INSERT must not access the table into which you are inserting values.

Locking:

Unless appropriate locks already exist, one or more exclusive locks are acquired at the execution of a successful insert operation. Until a commit or rollback operation releases the locks, only the application process that performed the insert can access the inserted row. If LOBs are not inserted into the row, application processes that are running with uncommitted read can also access the inserted row. The locks can also prevent other application processes from performing operations on the table. However, application processes that are running with uncommitted read can access locked pages and rows.

Locks are not acquired on declared temporary tables.

Inserting rows into a table with multilevel security :

When you insert rows into a table with multilevel security, Db2 determines the value for the security label column of the row according to the following rules:

- If the user (the primary authorization ID) has write-down privilege or write-down control is not enabled, the user can set the security label for the row to any valid security label. The value that is specified must be assignable to a column that is defined as CHAR(8) FOR SBCS DATA NOT NULL. If the user does not specify a value for the security label or specifies DEFAULT, the security label of the row becomes the same as the security label of the user.
- If the user does not have write-down privilege and write-down control is enabled, the security label of the row becomes the same as the security label of the user.

Inserting rows into a table for which row or column access control is enforced:

When an INSERT statement is issued for a table for which row or column access control is enforced, the rules specified in the enabled row permissions or column masks determine whether the row can be inserted. Typically those rules are based on the authorization ID or role of the process. The following rules describe how the enabled row permissions and column masks are used during INSERT:

- A row to be inserted must not be effected by enabled column masks whose columns are referenced while deriving the source values for the row.

When a column is referenced while deriving the values of a new row, if the column has an enabled column mask, the masked value is used to derive the new values. If the object table is also column access control activated, the column mask that is applied to derive the new values must ensure that the evaluation of the access control rules defined in the column mask resolves the column to itself, not to a constant or to an expression. If the column mask does not mask the column to itself, the new value cannot be used for insert and an error is returned at run time.

If the OVERRIDING USER VALUE clause is specified, the corresponding values in the new row are ignored, and the above rule for column masks is not applicable to those values.

- If the row can be inserted, and there is a BEFORE INSERT trigger for the table, the trigger is activated.

Within the trigger actions, the new values for insert can be modified in the transition variables. When the values return from the trigger, the final values for the new values are the ones for insert.

- A row to be inserted must conform to the enabled row permissions.

When multiple enabled row permissions are defined for a table, a row access control search condition is derived by application of the logical OR operator to the search condition in each enabled row permission. A row that conforms to the enabled row permissions is a row that if the row is inserted it can be retrieved back using the row access control search condition.

Column masks are not applicable in this process.

- If the rows can be inserted, and there is an AFTER INSERT trigger for the table, the trigger is activated.

The preceding rules are not applicable to the *include-columns*. The *include-columns* are subject to the rules for the select list because they are not the columns of the object table of the INSERT statement.

Extended indicators usage:

When extended indicators are enabled, indicator values other than positive values and 0 through -7 must not be specified. The DEFAULT and UNASSIGNED extended indicator values must not appear in contexts where they are not supported.

Extended indicators:

In an INSERT statement, the extended indicator value of UNASSIGNED has the effect of setting the column to its default value. If a target column is not updatable, it can only be assigned the extended indicator value of UNASSIGNED, unless it is an identity column defined as GENERATED ALWAYS. If the target column is an identity column defined as GENERATED ALWAYS, it must be assigned the DEFAULT keyword, or the extended indicator value of DEFAULT or UNASSIGNED.

Extended indicators and insert triggers:

The activation of insert triggers is not affected by the use of extended indicators. If all columns in the implicit or explicit column list have been assigned an extended indicator value of UNASSIGNED or DEFAULT, an insert in which all columns have their respective default values is attempted. If that insert is successful, the insert trigger is activated.

Extended indicators and deferred error checks:

When extended indicators are enabled, validation that would normally be done during statement preparation to recognize an insert into a non-updatable column is deferred until the statement is executed.

Table space data compression during an insert operation:

If the table space is defined with compression, and data is inserted into a table in the table space, the first rows are stored uncompressed. When a Db2-determined amount of data has been inserted into the table, a compression dictionary is created and stored in the table space. The rows that are inserted into the table after the dictionary is created are stored compressed using the compression dictionary.

Generated columns:

A generated column that is defined as GENERATED ALWAYS should not be specified in the *column-list* unless the corresponding entry in the VALUES list is DEFAULT or an extended indicator that specifies that a default value is to be assigned. Specify the OVERRIDING USER VALUE clause to indicate that any user-specified value should be ignored and Db2 should assign the default value when a row is inserted.

Inserting rows into system-period temporal tables:

When a row is inserted into a system-period temporal table, Db2 assigns values to the following columns as indicated:

- A row-begin column is assigned a value for the data type of the column. If the value of the SYSIBM.TEMPORAL_LOGICAL_TRANSACTION_TIME built-in global variable at the time of the insert is null, the value is generated using a reading of the time-of-day clock during execution of the first data change statement in the unit of work that requires a value to be assigned to a row-begin column or transaction-start-ID column in a table, or a row in a system-period temporal table is deleted. Otherwise, the row-begin column is assigned the value of the SYSIBM.TEMPORAL_LOGICAL_TRANSACTION_TIME built-in global variable at the time of the insert.
- A *row-end* column is assigned a value for the data type of the column.
- A *transaction-start-ID* column is assigned a unique value per unit of work or the null value. The null value is assigned to the *transaction-start-ID* column if the column is nullable. Otherwise, the value is generated by reading the time-of-day clock during execution of the first data change statement in the unit of work that requires a value to be assigned to a *row-begin* column or *transaction-start-ID* column in a table. This also occurs when a row in a system-period temporal table is deleted. If multiple rows are inserted within a single SQL transaction, the values for the *transaction-start-ID* column are the same for all the rows and are unique from the values that are generated for the column by another unit of work.

If the CURRENT TEMPORAL SYSTEM_TIME special register is set to a non-null value, the underlying target of the INSERT statement cannot be a system-period temporal table. This restriction applies regardless of whether the system-period temporal table is directly or indirectly referenced.

Inserting rows into application-period temporal tables:

When a row is inserted into an application-period temporal table, an error is returned if the period that is defined by the begin column and end column of the application period overlap with the period that is defined by the begin column and end column of the application period for another row in the table.

Inserting rows into archive-enabled tables:

You cannot insert rows into an archive-enabled table if the value of the SYSIBMADM.MOVE_TO_ARCHIVE global variable is Y. Otherwise, if this global variable is not set to Y, you can specify an archive-enabled table as the target of the INSERT statement. In this case, the content of the associated archive table is not affected.

A data change statement must not reference an archive-enabled table when a system-period temporal table or application-period temporal table is also referenced.

INSERT without a column list:

An INSERT statement without a column list does not include implicitly hidden columns, so columns that are defined as implicitly hidden must have a defined default value.

Inserting a row into catalog table SYSIBM.SYSSTRINGS:

If the object table is SYSIBM.SYSSTRINGS, only certain values can be specified, as described in [Specifying conversion procedures \(Db2 Administration Guide\)](#).

Datetime representation when using datetime registers:

As explained in [Datetime special registers](#), when two or more datetime registers are implicitly or explicitly specified in a single SQL statement, they represent the same point in time. This is also true when multiple rows are inserted. When ATOMIC is in effect for the INSERT statement, the special registers are evaluated one time for the processing of the statement. If NOT ATOMIC is in effect, the special registers are evaluated as each row of source data is processed.

Non-atomic processing of an INSERT statement:

When NOT ATOMIC is specified the rows of source data are processed separately. Any references to special registers, sequence expressions, and functions in the INSERT statement are evaluated as each row of source data is processed, Statement level triggers are activated as each row of source data is processed.

If one or more errors occur during the execution of an insert of a row, processing continues. The row that was being inserted at the time of the error is not inserted. Execution continues with the next row to be inserted, and any other changes made during the execution of the multiple-row INSERT statement are not backed out. However, the insert of an individual row is an atomic action.

Diagnostics information for a multiple-row INSERT statement:

A single multiple-row INSERT statement might encounter multiple conditions. These conditions can be errors or warnings. Use the GET DIAGNOSTICS statement to obtain information about all of the conditions that are encountered for one of these INSERT statements. See [“GET DIAGNOSTICS statement”](#) on page 1949 for more information.

If a warning occurs during the execution of an insert of a row, processing continues.

When multiple errors or warnings occur with a non-atomic INSERT statement, diagnostic information for each row is available using the GET DIAGNOSTICS statement. The SQLSTATE and SQLCODE reflect a summary of what happened during the INSERT statement:

- **SQLSTATE 01659, SQLCODE +252.** All rows were inserted, but one or more warnings occurred.
- **SQLSTATE 22529, SQLCODE -253.** At least one row was successfully inserted, but one or more errors occurred. Some warnings might also have occurred.
- **SQLSTATE 22530, SQLCODE -254.** No row was inserted. One or more errors occurred while trying to insert multiple rows of data.
- **SQLSTATE 429BI, SQLCODE -20252.** More errors occurred that Db2 is capable of recording. Statement processing is terminated.

When ATOMIC is in effect, if an insert value violates any constraints or if any other error occurs during the execution of an insert of a row, all changes made during the execution of the multiple-row INSERT statement are backed out. The SQLCA reflects the last warning encountered.

After an INSERT statement that inserts multiple rows of data, both atomic and non-atomic, information is returned to the program through the SQLCA. The SQLCA is set as follows:

- SQLCODE contains the SQLCODE.
- SQLSTATE contains the SQLSTATE.
- SQLERRD3 contains the number of rows actually inserted. SQLERRD3 is the number of rows inserted, if this is less than the number of rows requested, then an error occurred.
- SQLWARN flags are set if they were set during any single insert operation.

The SQLCA is used to return information on errors and warnings found during a multiple-row insert. If indicator arrays are provided, the indicator variable values are used to determine if the value from the host-variable array, or NULL, will be used. The SQLSTATE contains the warning from the last data mapping error.

Specifying the number of rows for a dynamic multiple-row INSERT statement:

Be aware of these considerations when specifying the number of rows to be inserted with a dynamic multiple-row INSERT statement that uses host-variable arrays:

- The FOR *n* ROWS clause can be specified as part of an INSERT statement or as part of an EXECUTE statement, but not both
- In the INSERT statement, you can specify a numeric constant in the FOR *n* ROWS clause to indicate the number of rows to be inserted or specify a parameter marker to indicate that the number of rows will be specified with the associated EXECUTE or OPEN statement. A multiple-row INSERT statement that is contained within a SELECT statement must include a FOR *n* ROWS clause.
- In an EXECUTE statement, when a dynamic INSERT statement is not contained within a SELECT statement, the number of rows can be specified with either the FOR *n* ROWS clause or the USING clause of the EXECUTE statement:
 - If the INSERT statement did not contain a FOR *n* ROWS clause, a value for the number of rows to be inserted can be specified in the FOR *n* ROWS clause of the EXECUTE statement with a numeric constant or host variable.
 - If a parameter marker was specified as part of a FOR *n* ROWS clause in the INSERT statement, a value for the number of rows must be specified with the USING clause of the EXECUTE statement.
- In an OPEN statement, when a dynamic SELECT statement contains one or more INSERT statements that have FOR *n* ROWS clauses with parameter markers, the values for the number of rows to be inserted (that is, the values for the parameter markers) must be specified with the USING clause of the OPEN statement.

DRDA considerations for a multiple-row INSERT statement:

Db2 for z/OS limits the size of user data and control information to 10M (except for LOBs, which are processed in a different data stream) for a single multiple-row INSERT statement using host-variable arrays.

When a multiple-row INSERT statement is executed at a Db2 for z/OS requester, the number of rows being inserted at the requester might not be known in some cases. These cases include:

- The FOR *n* ROWS clause contains a constant value for *n* for either a static or dynamic INSERT statement.
- Host variables are specified on the USING clause of an EXECUTE statement for a dynamic INSERT statement.

In either case, if the number of rows that is being inserted is not known, the requester might flow more data than is required to the server. The number of rows that is actually inserted will be correct because the server knows the correct number of rows to insert. However, performance can be adversely affected. Consider the following scenario:

```
...
long serial_num [10];
struct {
short len;
```

```

char data [18];
}name [20]
...
EXEC SQL INSERT INTO T1 VALUES (:serial_num, :name) FOR 5 ROWS

```

At the requester, when this statement is executed, the number of rows being inserted, 5, is not known. As a result, the requester will flow 10 values for `serial_num` and 10 values for `name` to the server (because the maximum number of rows that can be inserted without error is 10, which is the size of the smallest host-variable array).

Use the following programming techniques to avoid or minimize problems:

- Avoid using constant values for *n* in the FOR *n* ROWS clause of INSERT statements. For static INSERT statements, this technique ensures that the value for *n* will be known at the requester.
- For dynamic INSERT statements, use the USING DESCRIPTOR clause instead of the USING *host-variables* clause on the EXECUTE statement. If a USING DESCRIPTOR clause is used on the EXECUTE statement, the value for 'n' must be indicated in the DESCRIPTOR.
- If neither of the above methods can be used:
 - Declare your host-variable arrays as small as possible, or indicate that the size of your host-variable arrays are the size of 'n' in your descriptor. This avoids sending large numbers of host-variable-array entries that will not be used to the server.
 - Ensure that varying length string arrays are initialized to a length of 0 (zero). This minimizes the amount of data that is sent to the server.
 - Ensure that decimal host-variable arrays are initialized to valid values. This avoids a negative SQLCODE from being returned if the requester encounters invalid decimal data.

Other SQL statements in the same unit of work:

The following statements cannot follow an INSERT statement in the same unit of work:

- An ALTER TABLE statement that changes the data type of a column (ALTER COLUMN SET DATA TYPE)
- An ALTER INDEX statement that changes the padding attribute of an index with varying-length columns (PADDED to NOT PADDED or vice versa)
- A CREATE TABLE statement that creates an accelerator-only table.
- An INSERT, UPDATE, or DELETE statement that updates accelerator-only tables from a different accelerator.

Examples for INSERT

Example 1

Insert values into sample table DSN8C10.EMP.

```

INSERT INTO DSN8C10.EMP
VALUES ('000205', 'MARY', 'T', 'SMITH', 'D11', '2866',
       '1981-08-10', 'ANALYST', 16, 'F', '1956-05-22',
       16345, 500, 2300);

```

Example 2

Assume that SMITH.TEMPEMPL is a created temporary table. Populate the table with data from sample table DSN8C10.EMP.

```

INSERT INTO SMITH.TEMPEMPL
SELECT *
FROM DSN8C10.EMP;

```

Example 3

Assume that SESSION.TEMPEMPL is a declared temporary table. Populate the table with data from department D11 in sample table DSN8C10.EMP.

```
INSERT INTO SESSION.TEMPEMPL
SELECT *
FROM DSN8C10.EMP
WHERE WORKDEPT='D11';
```

Example 4

Insert a row into sample table DSN8C10.EMP_PHOTO_RESUME. Set the value for column EMPNO to the value in host variable HV_ENUM. Let the value for column EMP_ROWID be generated because it was defined with a row ID data type and with clause GENERATED ALWAYS.

```
INSERT INTO DSN8C10.EMP_PHOTO_RESUME(EMPNO, EMP_ROWID)
VALUES (:HV_ENUM, DEFAULT);
```

You can only insert user-specified values into ROWID columns that are defined as GENERATED BY DEFAULT and not as GENERATED ALWAYS. Therefore, in the above example, if you were to try to insert a value into EMP_ROWID instead of specifying DEFAULT, the statement would fail unless you also specify OVERRIDING USER VALUE. For columns that are defined as GENERATED ALWAYS, the OVERRIDING USER VALUE clause causes Db2 to ignore any user-specified value and generate a value instead.

For example, assume that you want to copy the rows in DSN8C10.EMP_PHOTO_RESUME to another table that has a similar definition (both tables have a ROWID columns defined as GENERATED ALWAYS). For the following INSERT statement, the OVERRIDING USER VALUE clause causes Db2 to ignore the EMP_ROWID column values from DSN8C10.EMP_PHOTO_RESUME and generate values for the corresponding ROWID column in B.EMP_PHOTO_RESUME.

```
INSERT INTO B.EMP_PHOTO_RESUME
OVERRIDING USER VALUE
SELECT * FROM DSN8C10.EMP_PHOTO_RESUME;
```

Example 5

Assume that the T1 table has one column. Insert a variable (:hv) number of rows of data into the T1 table. The values to be inserted are provided in a host-variable array (:hva).

```
EXEC SQL INSERT INTO T1 VALUES (:hva:hvind) FOR :hv ROWS ATOMIC;
```

In this example, :hva represents the host-variable array and :hvind represents the array of indicator variables.

Example 6

Assume that the T2 table has 2 columns, C1 is a SMALL INTEGER column, and C2 is an INTEGER column. Insert 10 rows of data into the T2 table. The values to be inserted are provided in host-variable arrays :hva1 (an array of INTEGERS) and :hva2 (an array of DECIMAL(15,0) values). The data values for :hva1 and :hva2 are represented in [Table 240 on page 2012](#):

Table 240. Data values for :hva1 and :hva2

Array entry	:hva1	:hva2
1	1	32768
2	-12	90000
3	79	2
4	32768	19
5	8	36
6	5	24

Table 240. Data values for :hva1 and :hva2 (continued)

Array entry	:hva1	:hva2
7	400	36
8	73	4000000000
9	-200	2000000000
10	35	88

```
EXEC SQL INSERT INTO T2 (C1, C2)
VALUES (:hva1:hvind1, :hva2:hvind2) FOR 10 ROWS
NOT ATOMIC CONTINUE ON SQLEXCEPTION;
```

After execution of the INSERT statement, the following information will be in the SQLCA:

```
SQLCODE = -253
SQLSTATE = 22529
SQLERRD3 = 8
```

Although an attempt was made to insert 10 rows, only 8 rows of data were inserted. Processing continued after the first failed insert because NOT ATOMIC CONTINUE ON SQLEXCEPTION was specified. You can use the GET DIAGNOSTICS statement to find further information, for example:

```
GET DIAGNOSTICS :num_rows = ROW_COUNT, :num_cond = NUMBER;
```

The result of this statement is num_rows = 8 and num_cond = 2 (2 conditions).

```
GET DIAGNOSTICS CONDITION 2 :sqlstate = RETURNED_SQLSTATE,
                             :sqlcode = DB2_RETURNED_SQLCODE,
                             :row_num = DB2_ROW_NUMBER;
```

The result of this statement is sqlstate = 22003, sqlcode = -302, and row_num = 4.

```
GET DIAGNOSTICS CONDITION 1 :sqlstate = RETURNED_SQLSTATE,
                             :sqlcode = DB2_RETURNED_SQLCODE,
                             :row_num = DB2_ROW_NUMBER;
```

The result of this statement is sqlstate = 22003, sqlcode = -302, and row_num = 8.

Example 7

Assume the above table T2 with two columns. C1 is a SMALL INTEGER column, and C2 is an INTEGER column. Insert 8 rows of data into the T2 table. The values to be inserted are provided in host-variable arrays :hva1 (an array of INTEGERS) and :hva2 (an array of DECIMAL(15,0) values.) The data values for :hva1 and :hva2 are represented in [Table 240 on page 2012](#).

```
EXEC SQL INSERT INTO T2 (C1, C2)
VALUES (:hva1:hvind1, :hva2:hvind2) FOR 8 ROWS
NOT ATOMIC CONTINUE ON SQLEXCEPTION;
```

After execution of the INSERT statement, the following information will be in the SQLCA:

```
SQLCODE = -253
SQLSTATE = 22529
SQLERRD3 = 6
```

Although an attempt was made to insert 8 rows, only 6 rows of data were inserted. Processing continued after the first failed insert because NOT ATOMIC CONTINUE ON SQLEXCEPTION was specified. You can use the GET DIAGNOSTICS statement to find further information, for example:

```
GET DIAGNOSTICS :num_rows = ROW_COUNT, :num_cond = NUMBER;
```

The result of this statement is num_rows = 68 and num_cond = 2 (2 conditions).

```

GET DIAGNOSTICS CONDITION 2 :sqlstate = RETURNED_SQLSTATE,
                           :sqlcode = DB2_RETURNED_SQLCODE,
                           :row_num = DB2_ROW_NUMBER;

```

The result of this statement is sqlstate = 22003, sqlcode = -302, and row_num = 4.

```

GET DIAGNOSTICS CONDITION 1 :sqlstate = RETURNED_SQLSTATE,
                           :sqlcode = DB2_RETURNED_SQLCODE,
                           :row_num = DB2_ROW_NUMBER;

```

The result of this statement is sqlstate = 22003, sqlcode = -302, and row_num = 8.

Example 8

Assume that table T1 has two columns. Insert a variable number (:hvn) or rows into T1. The values to be inserted are in host-variable arrays :hva and :hvb. In this example, the INSERT statement is contained within the SELECT statement of cursor CS1. The SELECT statement makes use of two other input host variables (:hv1 and :hv2) in the WHERE clause. Either a static or dynamic INSERT statement can be used.

```

-- Static INSERT statement:
DECLARE CS1 CURSOR WITH ROWSET POSITIONING FOR
  SELECT *
    FROM FINAL TABLE
      (INSERT INTO T1 VALUES (:hva, :hvb) FOR :hvn ROWS)
  WHERE C1 > :hv1 AND C2 < :hv2;
OPEN CS1;
-- Dynamic INSERT statement:
PREPARE INSSMT FROM
  'SELECT *
    FROM FINAL TABLE
      (INSERT INTO T1 VALUES ( ? , ? ) FOR ? ROWS)
  WHERE C1 > ? AND C2 < ?';
DECLARE CS1 CURSOR WITH ROWSET POSITIONING FOR :INSSMT;
OPEN CS1 USING :hva, :hvb, :hvn, :hv1, :hv2; (or OPEN CS1 USING DESCRIPTOR ...)

```

If the host-variable arrays for the multiple-row INSERT statement were to be specified using a descriptor, that descriptor (SQLDA) would have to describe all input host variables in the statement, and the order of the entries in the SQLDA should be the same as the order of the order of the host variables, host-variable arrays, and values for the FOR n ROWS clauses in the statement. For example, given the statement above, the SQLVAR entries in the descriptor must be assigned in the following order: :hvn, :hva, :hvb, :hv1, hv2. In addition, the SQLVAR entries for host-variable arrays must be tagged in the SQLDA as column arrays (by specifying a special value in part of the SQLNAME field for a host variable), and the SQLVAR entry for the number of rows value must be tagged in the SQLDA (by specifying another special value in part of the SQLNAME field for the host variable).

Example 9

Insert a row into table T1. The row contains the value 'xyz' for column COL1, and the cardinality of array INTA for column COL2.

```

CREATE TYPE INTARRAY AS INTEGER ARRAY [6];
CREATE VARIABLE INTA AS INTARRAY;
SET INTA = ARRAY [ 1, 2, 3, 4, 5 ];
CREATE TABLE T1 (COL1 CHAR(7), COL2 INT);
INSERT INTO T1 VALUES ('xyz', CARDINALITY(INTA));

```

Example 10

Insert the values from arrays CHARA and INTA into table T1. For a row of T1, a value of the CHARA array is used for column COL1, and the value of the INTA array with the same array index is used for column COL2.

```

CREATE TYPE INTARRAY AS INTEGER ARRAY[10];
CREATE TYPE CHARARRAY AS CHAR(7) ARRAY[10];
CREATE VARIABLE INTA AS INTARRAY;
CREATE VARIABLE CHARA AS CHARARRAY;
SET INTA = ARRAY[1, 2, 3, 4, 5];
SET CHARA = ARRAY['a', 'b', 'c', 'd'];
CREATE TABLE T1 (COL1 CHAR(7), COL2 INT);
INSERT INTO T1

```

```
SELECT *  
FROM UNNEST(CHARA, INTA) AS (COL1, COL2);
```

Example 11

Insert three rows of data into table T1. For each inserted row, assign the value of the tenth element in the INTA array variable to the COL1 column.

```
CREATE TYPE INTARRAY AS INTEGER ARRAY[10];  
CREATE VARIABLE INTA AS INTARRAY;  
CREATE VARIABLE VAR1 AS INTEGER;  
CREATE VARIABLE VAR2 AS INTEGER;  
SET INTA = ARRAY[10, 20, 30, 40, 50, 60, 70, 80, 90, 100];  
CREATE TABLE T1 (COL1 INT, COL2 CHAR(10));  
SET VAR1 = 10;  
SET VAR2 = 3;  
-- Perform a multiple row insert (specifying a FOR n ROWS clause).  
-- The value to be inserted is specified by a reference to an array element.  
INSERT INTO T1 (COL1) VALUES(INTA[VAR1]) FOR VAR2 ROWS;
```

The result of these operations is that a value of 100 is assigned to column COL1 for three rows.

LABEL statement

The LABEL statement adds or replaces labels in the descriptions of tables, views, aliases, or columns in the catalog at the current server.

Invocation for LABEL

This statement can be embedded in an application program or issued interactively. It is an executable statement that can be dynamically prepared.

Authorization for LABEL

The privilege set that is defined below must include at least one of the following:

- Ownership of the table, view, or alias
- DBADM authority for its database (tables only)
- SYSADM or SYSCTRL authority
- System DBADM

If the database is implicitly created, the database privileges must be on the implicit database or on DSNDDB04.

Privilege set: If the statement is embedded in an application program, the privilege set is the privileges that are held by the owner of the plan or package. If the statement is dynamically prepared, the privilege set is determined by the DYNAMICRULES behavior in effect (run, bind, define, or invoke) and is summarized in [Table 171 on page 1089](#). (For more details on these behaviors, including a list of the DYNAMICRULES bind option values that determine them, see [“Authorization IDs and dynamic SQL” on page 94](#).)

Syntax for LABEL

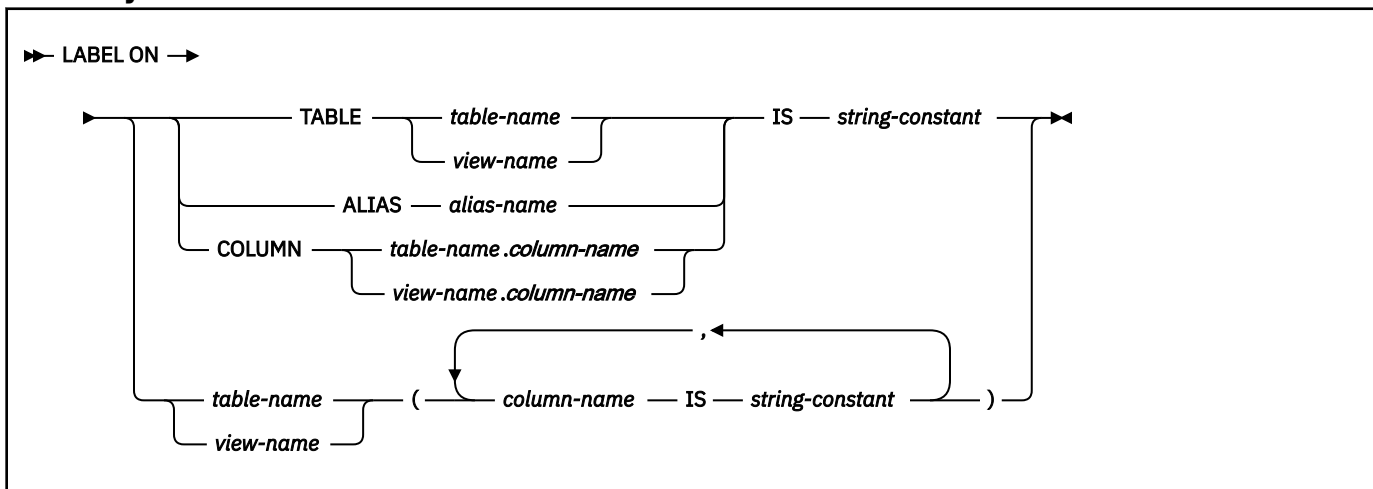

Description for LABEL

TABLE *table-name* or *view-name*

Identifies the table or view to which the label applies. The name must identify a table or view that exists at the current server. *table-name* must not identify a declared temporary table. The label is placed into the LABEL column of the SYSIBM.SYSTABLES catalog table for the row that describes the table or view.

ALIAS *alias-name*

Identifies the alias to which the label applies. The name must identify an alias for a table or view that exists at the current server. The label is placed in the LABEL column of the SYSIBM.SYSTABLES catalog table for the row that describes the alias.

COLUMN *table-name.column-name* or *view-name.column-name*

Identifies the column to which the label applies. The name must identify a column of a table or view that exists at the current server. The name must not identify a column of a declared temporary table. The label is placed in the LABEL column of the SYSIBM.SYSCOLUMNS catalog table in the row that describes the column.

Do not use TABLE or COLUMN to define a label for more than one column in a table or view. Give the table or view name and then, in parentheses, a list in the form:

```
column-name IS string-constant,
column-name IS string-constant,...
```

See Example 2 below.

The column names must not be qualified, each name must identify a column of the specified table or view, and that table or view must exist at the current server.

IS

Introduces the label you want to provide.

string-constant

Can be any SQL character string constant of up to 30 bytes in length.

Examples for LABEL

Example 1: Enter a label on the DEPTNO column of table DSN8C10.DEPT.

```
LABEL ON COLUMN DSN8C10.DEPT.DEPTNO
IS 'DEPARTMENT NUMBER';
```

Example 2: Enter labels on two columns in table DSN8C10.DEPT.

```
LABEL ON DSN8C10.DEPT
(MGRNO IS 'EMPLOYEE NUMBER FOR THE MANAGER',
ADMNDEPT IS 'ADMINISTERING DEPARTMENT');
```

LOCK TABLE statement

The LOCK TABLE statement requests a lock on a table or table space at the current server. The lock is not acquired if the process already holds an appropriate lock.

Invocation for LOCK TABLE

This statement can be embedded in an application program or issued interactively. It is an executable statement that can be dynamically prepared.

Authorization for LOCK TABLE

The privilege set that is defined below must include at least one of the following:

- The SELECT privilege on the identified table (the SELECT privilege does not apply to the auxiliary table)
- Ownership of the table
- DBADM authority for the database
- SYSADM or SYSCTRL authority
- DATAACCESS authority

If the database is implicitly created, the database privileges must be on the implicit database or on DSNDBO4.

Privilege set: If the statement is embedded in an application program, the privilege set is the privileges that are held by the owner of the plan or package. If the statement is dynamically prepared, the privilege set is determined by the DYNAMICRULES behavior in effect (run, bind, define, or invoke) and is summarized in [Table 171 on page 1089](#). (For more details on these behaviors, including a list of the DYNAMICRULES bind option values that determine them, see [“Authorization IDs and dynamic SQL” on page 94](#).)

Syntax for LOCK TABLE

```
▶▶ LOCK TABLE — table-name — PARTITION — integer — IN — SHARE — EXCLUSIVE —
◀◀ MODE ▶▶
```

Description for LOCK TABLE

table-name

Identifies the table to be locked. The name must identify a table that exists at the current server. It must not identify a view, a temporary table (created or declared), an accelerator-only table, a catalog table, or a directory table. The lock might or might not apply exclusively to the table. The effect of locking an auxiliary table is to lock the LOB table space that contains the auxiliary table.

PARTITION *integer*

Identifies the partition of a partitioned table space to lock. The table identified by *table-name* must belong to a partitioned table space. The value specified for *integer* must be an integer that is no greater than the number of partitions in the table space.

IN SHARE MODE

For a lock on a table that is not an auxiliary table, requests the acquisition of a lock that prevents other processes from executing anything but read-only operations on the table. For a lock on a LOB table space, IN SHARE mode requests a lock that prevents storage from being reallocated. When a LOB table space is locked, other processes can delete LOBs or update them to a null value, but they cannot insert LOBs with a nonnull value. The type of lock that the process holds after execution of the statement depends on what lock, if any, the process already holds.

IN EXCLUSIVE MODE

Requests the acquisition of an exclusive lock for the application process. Until the lock is released, it prevents concurrent processes from executing any operations on the table.

Exceptions: Unless the lock is on a LOB table space, a partitioned (non-UTS) table space, or a universal table space (UTS), concurrent processes that are running with an isolation level of uncommitted read (UR) can execute read-only operations on the table. Concurrent processes that are running with an isolation level of cursor stability (CS) with CURRENTDATA(NO) can execute read-only operations on the table when lock avoidance is used to read data that is already committed.

Be aware that an exclusive lock on a table space, table, or partition does not prevent other transactions from holding claims on the locked object.

Notes for LOCK TABLE

Releasing locks

If LOCK TABLE is a static SQL statement, the RELEASE option of bind determines when Db2 releases a lock. For RELEASE(COMMIT), Db2 releases the lock at the next commit point. For RELEASE(DEALLOCATE), Db2 releases the lock when the plan is deallocated (the application ends).

If LOCK TABLE is a dynamic SQL statement, Db2 uses RELEASE(COMMIT) and releases the lock at the next commit point, unless the table or table space is referenced by cached dynamic statements. Caching allows Db2 to keep prepared statements in memory past commit points. In this case, Db2 holds the lock until deallocation or until the commit after the prepared statements are freed from memory. Under some conditions, if a lock is held past a commit point, Db2 demotes the lock state of a segmented table or a nonsegmented table space to an intent lock at the commit point.

When you issue a MODIFY DDF command with the PKGREL(BNDOPT) or PKGREL(BNDPOOL) options, the use of processor resources for package allocation and deallocation are minimized for packages that use database access threads and are bound with the RELEASE(DEALLOCATE) option. When the MODIFY DDF PKGREL command is issued with these options, Db2 honors the RELEASE bind option even for dynamic SQL statements.

Syntax alternatives and synonyms

For compatibility with previous releases of Db2, PART can be specified as a synonym for PARTITION.

Example for LOCK TABLE

Obtain a lock on the sample table named DSN8C10.EMP, which resides in a partitioned table space. The lock obtained applies to every partition and prevents other application programs from either reading or updating the table. However, under one of the conditions that are noted above under **Exceptions**, Db2 might allow read-only operations on the table.

```
LOCK TABLE DSN8C10.EMP IN EXCLUSIVE MODE;
```

Related concepts

[Lock size \(Db2 Performance\)](#)

[The duration of a lock \(Db2 Performance\)](#)

[Lock avoidance \(Db2 Performance\)](#)

Related tasks

[Controlling concurrent access to tables \(Db2 Performance\)](#)

[Programming for concurrency \(Db2 Performance\)](#)

Related reference

[ISOLATION bind option \(Db2 Commands\)](#)

[RELEASE bind option \(Db2 Commands\)](#)

[DYNAMICRULES bind option \(Db2 Commands\)](#)

MERGE statement

The MERGE statement updates a target (a table or view) using data from a source (the result of a table reference or the specified input data). Rows in the target that match the input data can be deleted or updated as specified, and rows that do not exist in the target can be inserted. Updating, deleting, or inserting a row into a view updates, deletes, or inserts the row into the tables on which the view is based, if no INSTEAD OF trigger is defined on this view.

Invocation for MERGE

This statement can be embedded in an application program or issued interactively. It is an executable statement that can be dynamically prepared.

Authorization for MERGE

The privileges that are held by the privilege set that is defined below must include at least one of the following privileges:

- SYSADM authority
- Ownership of the table
- DATAACCESS authority
- If the search condition contains a reference to a column of the table or view, the SELECT privilege for the referenced table or view
- If the delete operation is specified, the DELETE privilege for the table or view
- If the insert operation is specified, the INSERT privilege for the table or view
- If the update operation is specified, at least one of the following privileges is required:
 - the UPDATE privilege for the table or view
 - the UPDATE privilege on each column that is updated
 - If the right side of the assignment clause contains a reference to a column of the table or view, the SELECT privilege for the referenced table or view

If the database is implicitly created, the database privileges must be on the implicit database or on DSNDBO4.

If the insert operation or assignment clause includes a subquery, the privileges that are held by the privilege set must also include at least one of the following privileges:

- SYSADM authority
- The SELECT privilege on every table or view that is identified in the subquery
- Ownership of the tables or views that are identified in the subquery
- DATAACCESS authority

Privilege set: If the statement is embedded in an application program, the privilege set is the privileges that are held by the owner of the plan or package. If the statement is dynamically prepared, the privilege set is determined by the DYNAMICRULES behavior in effect (run, bind, define, or invoke) and is summarized in [Table 171 on page 1089](#). (For more information on these behaviors, including a list of the DYNAMICRULES bind option values that determine them, see [“Authorization IDs and dynamic SQL” on page 94](#).)

Syntax for MERGE

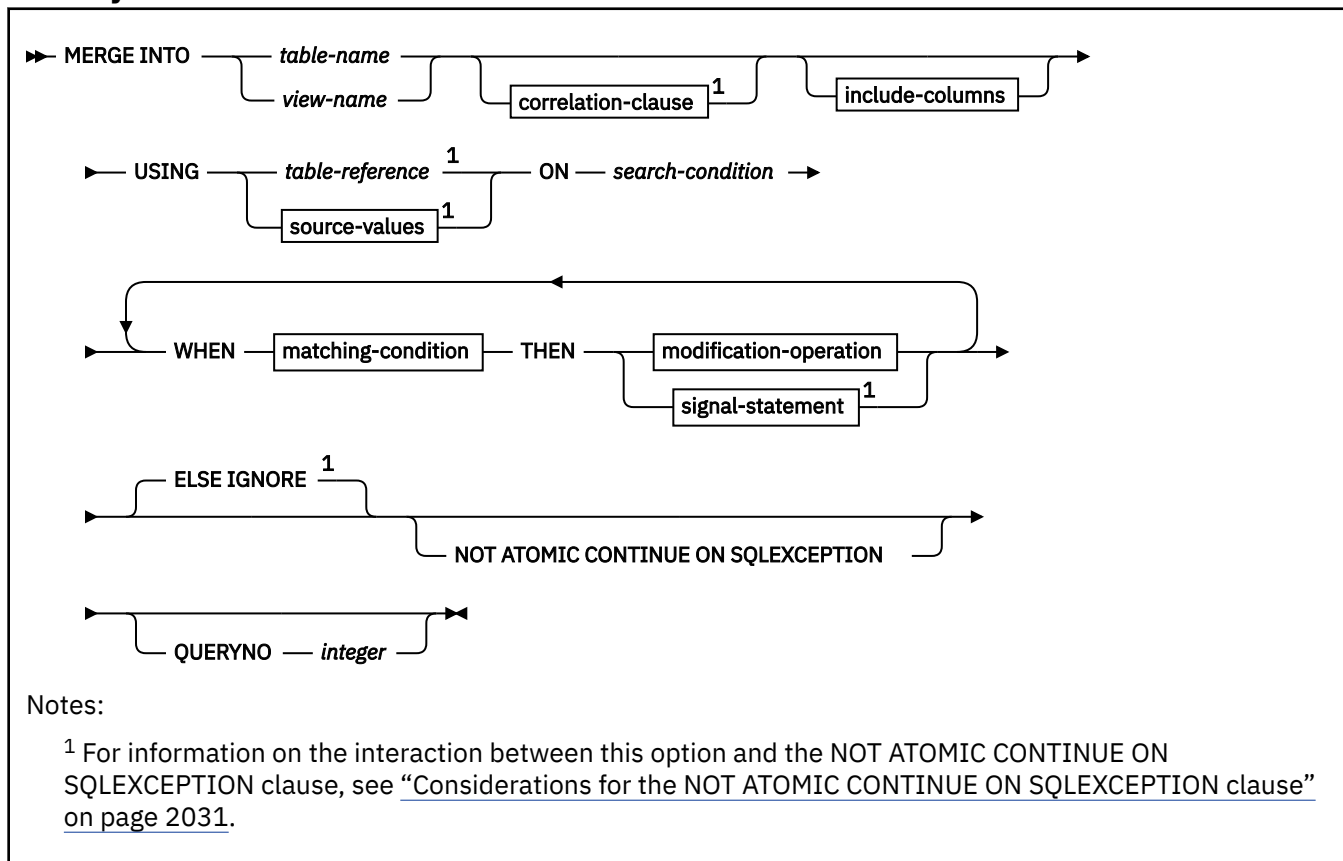

correlation-clause:

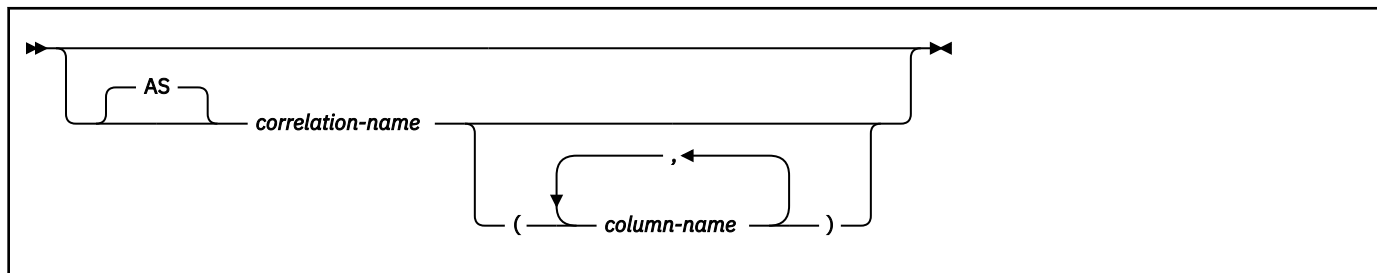

include-columns:

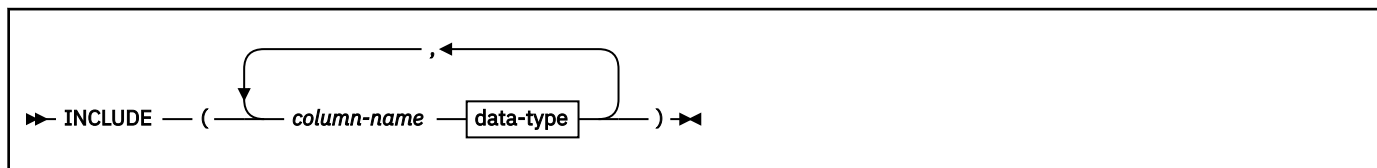

data-type:

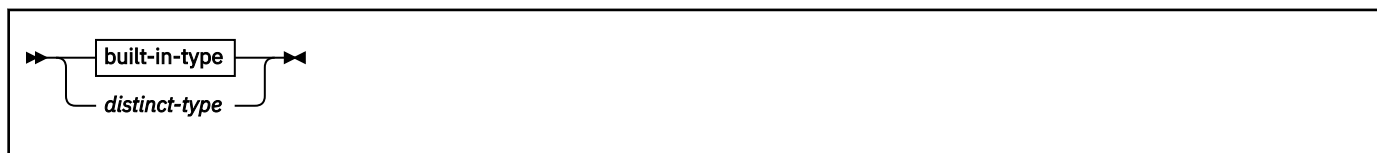

built-in-type:

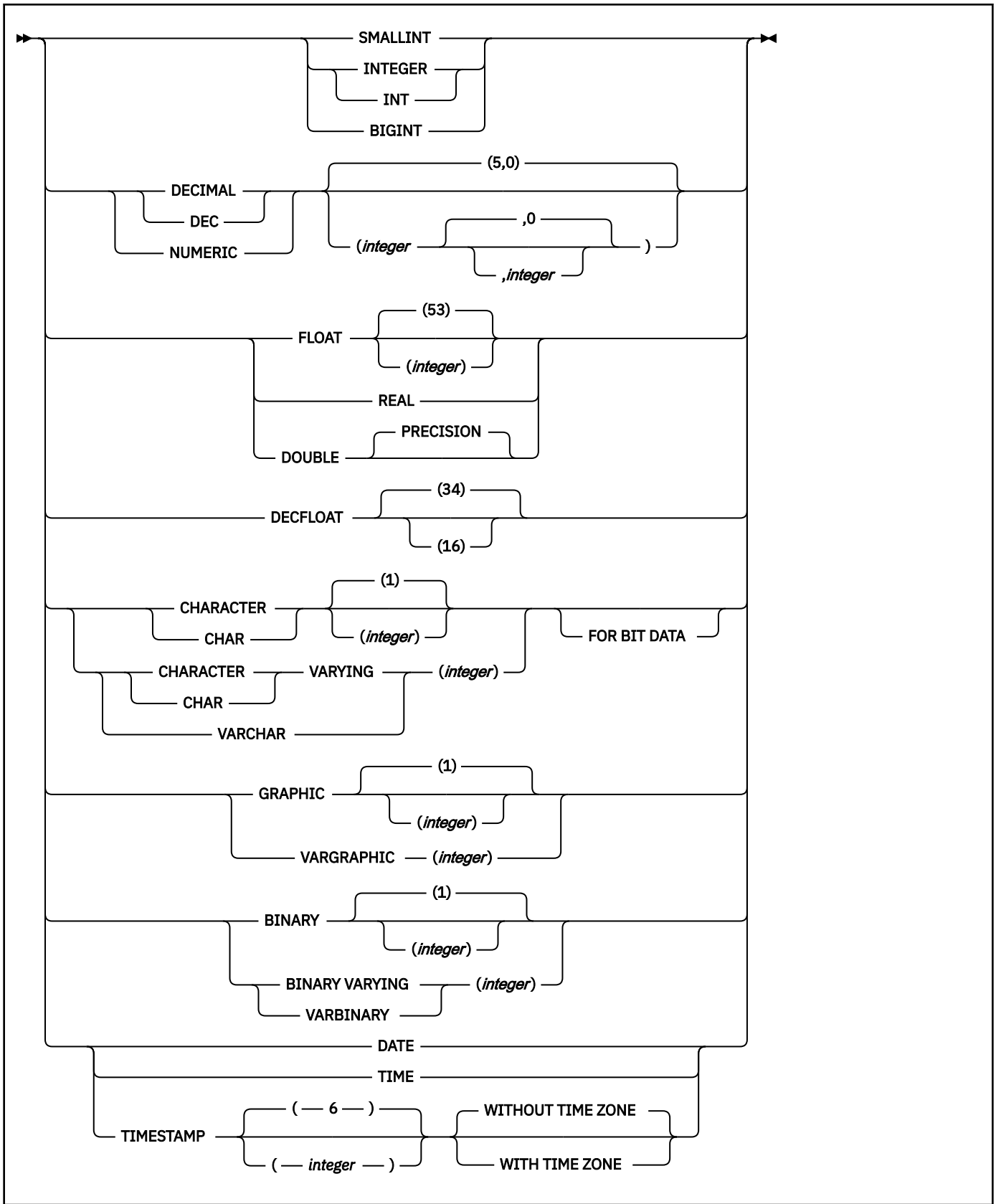

source-values:

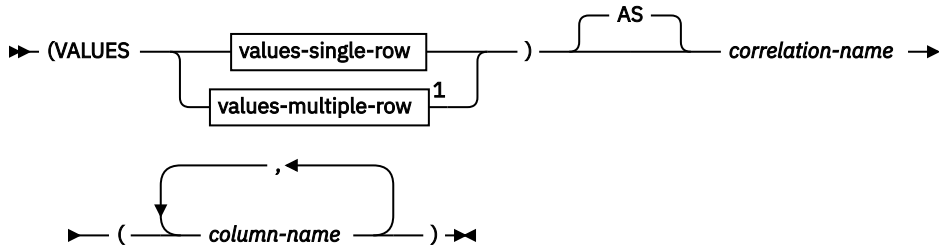

Notes:

¹ The NOT ATOMIC CONTINUE ON SQLEXCEPTION clause must be specified when *values-multiple-row* is specified.

values-single-row:

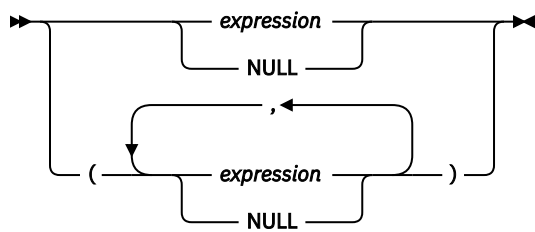

values-multiple-row:

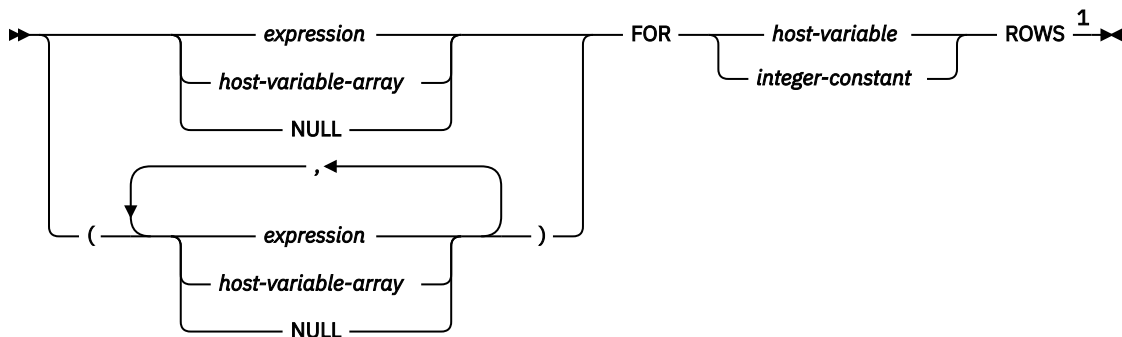

Notes:

¹ For a static MERGE statement, if FOR n ROWS is not specified, *values-multiple-row* is treated as *values-single-row*. For a dynamic MERGE statement, FOR n ROWS does not need to be specified in the MERGE statement. It can be specified in the EXECUTE statement, but cannot be specified in both the MERGE and EXECUTE statements.

matching-condition:



Notes:

¹ For information on the interaction between this option and the NOT ATOMIC CONTINUE ON SQLEXCEPTION clause, see [“Considerations for the NOT ATOMIC CONTINUE ON SQLEXCEPTION clause” on page 2031.](#)

modification-operation:

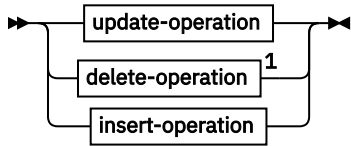

Notes:

¹ For information on the interaction between this option and the NOT ATOMIC CONTINUE ON SQLEXCEPTION clause, see [“Considerations for the NOT ATOMIC CONTINUE ON SQLEXCEPTION clause” on page 2031.](#)

assignment-clause:

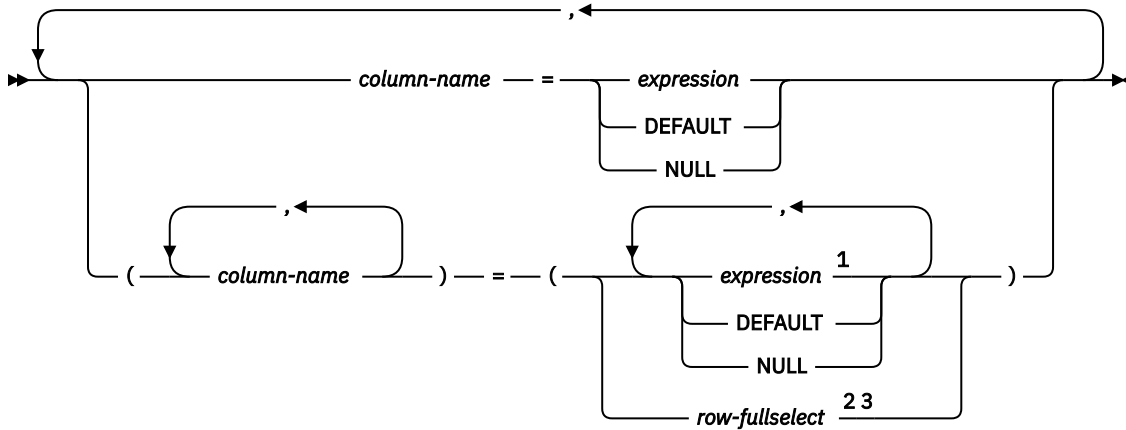

Notes:

- ¹ The number of expressions, DEFAULT, and NULL keywords must match the number of *column-names*.
- ² The number of columns in the SELECT list must match the number of *column-names*.
- ³ For information on the interaction between this option and the NOT ATOMIC CONTINUE ON SQLEXCEPTION clause, see [“Considerations for the NOT ATOMIC CONTINUE ON SQLEXCEPTION clause” on page 2031.](#)

update-operation:

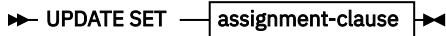

delete-operation:



insert-operation:

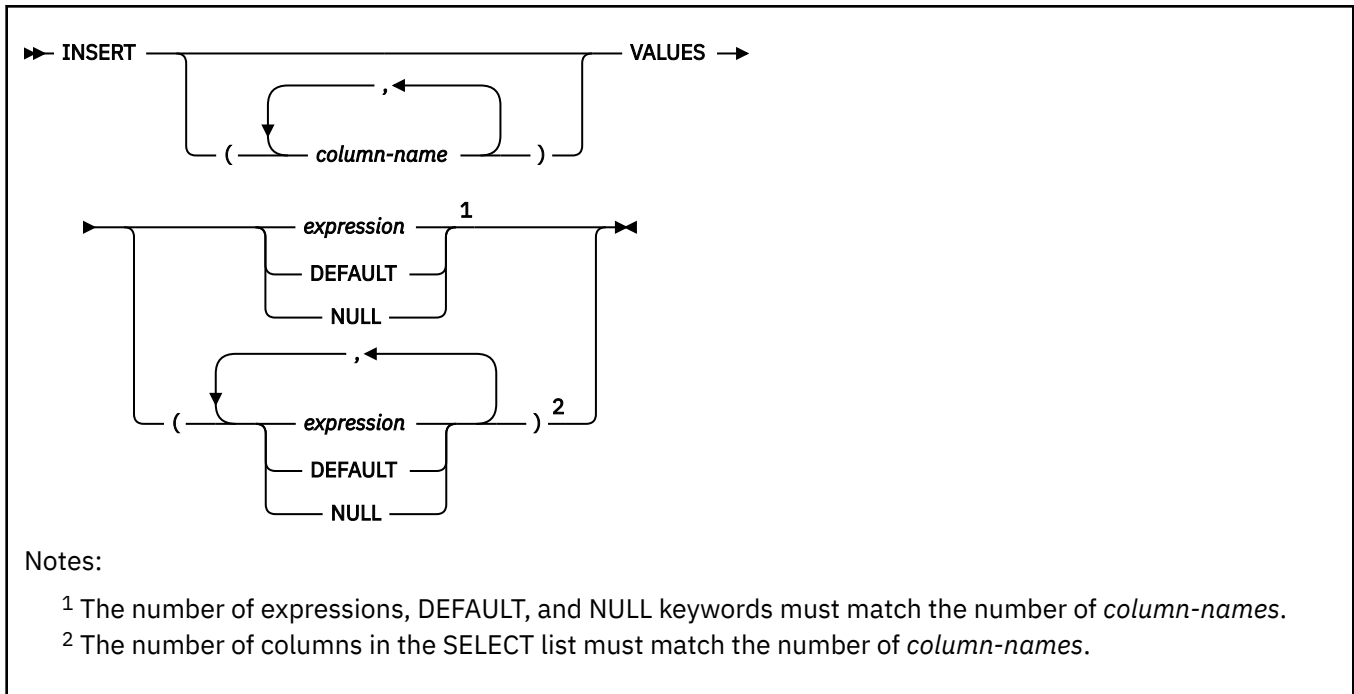

Description for MERGE

INTO *table-name* or *view-name*

Identifies the target of the update, insert, or delete operations of the merge. The name must identify a table or view that exists at the current server. The name must not identify:

- A catalog table
- A directory table
- A created global temporary table
- A read-only view
- A system-maintained materialized query table
- A table that is implicitly created for an XML column
- An accelerator-only table

If a view is specified as the target of the MERGE statement, the view must not be defined with any INSTEAD OF triggers.

AS *correlation-name*

correlation-name provides an alternative name that can be used when referencing columns of target table.

The correlation name can be used within *search-condition*, *matching-condition*, or as part of a source value for an assignment, to designate the target table or view. The *correlation-name* is used to qualify references to the columns of the table or view. For a description of *correlation-clause*, see [“table-reference”](#) on page 1018.

column-name

Specifies a column name. When a *correlation-name* is specified, *column-names* can also be specified to give names to the columns of the target *table-name* or *view-name*. If a column list is specified, there must be a name in the column list for each column in the table or view.

include-columns

Specifies a set of columns that are included, along with the columns of the specified table or view, in the result table of the MERGE statement when it is nested in the FROM clause of the outer fullselect that is used in a SELECT statement, or in a SELECT INTO statement. The included columns are

appended to the end of the list of columns that are identified by *table-name* or *view-name*. If a value is not specified for an included column, a null value is returned for that column.

INCLUDE

Introduces a list of columns that is to be included in the result table of the MERGE statement. The included columns are only available if the MERGE statement is nested in the FROM clause of a SELECT statement or a SELECT INTO statement. INCLUDE can only be specified when the MERGE statement is nested in the FROM clause of a SELECT statement.

column-name

Specifies the name for a column of the result table of the MERGE statement that is not the same name as another included column or a column in the table or view that is specified in *table-name* or *view-name*.

data-type

Specifies the data type of the included column. The included columns are nullable.

Columns with the following data types can not be used as INCLUDE columns:

- LONG VARCHAR,
- LONG VARGRAPHIC,
- XML
- LOBs
- distinct types that are based on any of the listed data types.

built-in-type

Specifies a built-in data type. See [“CREATE TABLE statement” on page 1650](#) for a description of each built-in type.

The CCSID 1208 and CCSID 1200 clauses must not be specified for an INCLUDE column.

distinct-type

Specifies a distinct type. Any length, precision, or scale attributes for the column are those of the source type of the distinct type as specified by using the CREATE TYPE statement.

USING

Specifies a set of rows as a result table to be merged into the target.

table-reference

Specifies a set of rows as a result table to be merged into the target. If the result table is empty, a warning is returned.

source-values

VALUES values-single-row or values-multiple-row

Specifies the values for a set of rows as a result table to be merged into the target. *values-single-row* specifies a single row of source data. *values-multiple-row* specifies multiple rows of source data. The number of values must not exceed 750.

expression

Specifies an expression of the type that is described in [“Expressions” on page 245](#). The expression must not include a column name. The expression must not reference a NEXT VALUE or PREVIOUS VALUE expression. If the expression is a single host variable, the host variable can identify a structure. Any host variable or structure that is specified must be described in the application program according to the rules for declaring host structures and variables.

host-variable-array

Specifies a host-variable array. Each host-variable array must be defined in the application program in accordance with the rules for declaring an array. A host-variable array contains the data to merge into a target column. The number of rows must be less than or equal to the dimension of each of the host-variable arrays. An optional indicator array can be specified for each host-variable array. An indicator array should be specified if the SQLTYPE of any SQLVAR occurrence indicates that a column is nullable. The indicator array

can be enabled for extended indicator variables. The dimension of the indicator array must be large enough to contain an indicator for each row of input data.

A host structure is not supported in *host-variable-array*.

host-variable-array is supported in C/C++, COBOL, and PL/I. For more information, see [“Host-variable arrays in PL/I, C, C++, and COBOL”](#) on page 236.

NULL

Specifies a null value.

The *column-name* that is specified in *source-values* corresponding to the NULL keyword is used to determine the data type of the null value. The *column-name* that is specified in *source-values* must be referenced elsewhere in the MERGE statement such that its data type can be determined from the context in which it is used, and all such references must resolve to the same data type. References to date-time data types and CHAR or VARCHAR are considered the same type.

FOR *host-variable* or *integer-constant* ROWS

Specifies the number of rows to merge. For a dynamic MERGE statement, this clause can be specified on the EXECUTE statement. *host-variable* or *integer-constant* is assigned to a value *k*. If *host-variable* is specified, it must be an exact numeric type with a scale of zero and must not include an indicator variable. *k* must be in the range 1–32767. *k* rows are merged into the target from the specified source data.

If a parameter marker is specified in FOR *n* ROWS, a value must be provided with the USING clause of the associated EXECUTE statement.

AS *correlation-name*

Specifies a correlation name for the *source-values*. The *correlation-name* is used to qualify references to the columns of *source-values*.

column-name

Specifies a column name. When a *correlation-name* is specified, *column-names* can also be specified to give names to the columns of *source-values* for an assignment. If a column list is specified, there must be a name in the column list for each column in *source-values*.

ON *search-condition*

Specifies the predicates that are used to determine whether a row from *table-reference* or *source-values* matches rows in the target table.

Each *column-name* in the search condition must name a column of the target table or view, or *table-reference* or *source-values*. If a *column-name* exists in both the target and the *source-values*, the column name must be qualified.

Logically, a right join is performed between the target table and the *table-reference* (or *source-values*) using the ON *search-condition*. For those rows of the join result table where the search condition is true, the specified update or delete operation is performed. For those rows of the join result table where the result of the search condition is not true, the specified insert operation is performed.

A subquery is not allowed in the *search-condition* of the ON clause. The *search-condition* of the ON clause cannot contain expressions that use aggregate functions or non-deterministic scalar functions.

The *search-condition* of the ON clause must not include an IN predicate that includes a fullselect, or a quantified predicate that includes a fullselect.

WHEN *matching-condition*

Specifies the condition under which the *modification-operation* or the *signal-statement* is executed. Each *matching-condition* is evaluated in order of specification. When NOT ATOMIC CONTINUE ON SQLEXCEPTION is not specified, rows for which the *matching-condition* evaluates to true are not considered in subsequent matching conditions.

MATCHED

Indicates the operation to perform on the rows where the ON *search-condition* is true. Only UPDATE, DELETE, or *signal-statement* can be specified after the THEN clause.

AND search-condition

Specifies a further search condition to be applied against the rows that matched the ON search condition for the operation to be performed after THEN. The *search-condition* must not include an IN predicate that includes a fullselect, or a quantified predicate that includes a fullselect.

NOT MATCHED

Indicates the operation to perform on the rows where the ON *search-condition* is false or unknown, or the target table is empty. Only INSERT or *signal-statement* can be specified after the THEN clause, and must not reference a column of the target table.

AND search-condition

Specifies a further search condition to be applied against the rows that did not match the ON search condition for the operation to be performed after THEN. The *search-condition* must not include a column of the target table.

THEN modification-operation

Specifies the operation to be executed when the *matching-condition* evaluates to true.

update-operation

Specifies the update operation to be executed when the *matching-condition* evaluates to true.

UPDATE

Introduces the update operation.

When extended indicators are enabled, a column of the source table must not be referenced multiple times in a single *modification-operation*. Extended indicators are enabled when EXTENDEDINDICATOR(YES) is used, or when the WITH EXTENDED INDICATORS prepare attribute has been specified for the MERGE statement.

When NOT ATOMIC CONTINUE ON SQLEXCEPTION is specified, or the NOT ATOMIC CONTINUE ON SQLEXCEPTION clause is not specified, and *source-values* (VALUES) is specified, the rows that are updated from a source row are subject to more updates by subsequent source rows in the same statement. The update is cumulative.

An *update-operation* in a MERGE statement does not reset the AREO* status on a table.

SET

Introduces the assignment of values to column names.

assignment-clause

Specifies a list of column updates.

If *row-fullselect* is specified, the number of columns in the result of *row-fullselect* must match the number of *column-names* that are specified. If *row-fullselect* is not specified, the number of expressions, and NULL and DEFAULT keywords must match the number of *column-names* that are specified.

column-name

Identifies a column to update. *column-name* must identify a column of the specified table or view, and that column must be updatable. The column must not be a generated column, or a column of a view that is derived from a scalar function, a constant, or an expression. *column-name* can also identify an included column. The same *column-name* must not be specified more than one time. A view column that is derived from the same column as another column of the view can be updated, but both columns cannot be updated in the same MERGE statement.

Assignments to included columns are only processed when the MERGE statement is nested in the FROM clause of a SELECT statement or a SELECT INTO statement. There must be at least one assignment clause that specifies a *column-name* that is not an included column.

expression

Specifies the new value of the column. The expression is any expression of the type that is described in [“Expressions” on page 245](#). The expression must not include an aggregate function.

The expression can contain references to columns of *table-name*, *view-name*, *table-reference*, or *source-values*. For each row that is updated, the value of a target column in an expression is the value of the column in the row before the row is updated. *expression* cannot contain references to an included column.

If *expression* is a reference to a single column of the source table, the source table column value might have been specified with an extended indicator value. The effects of extended indicator values apply to the corresponding target columns of the *assignment-clause*.

When extended indicators are enabled, the extended indicator values of DEFAULT (-5) or UNASSIGNED (-7) must not be used if *expression* is more complex than the following references:

- A single column of the source table
- A single host variable

DEFAULT

Specifies the default value for the column. DEFAULT can be specified only for columns that have a default value. DEFAULT must not be specified for a ROWID column. The value that is assigned depends on how the column is defined. For more information about default values, see the description of the DEFAULT clause in [“CREATE TABLE statement” on page 1650](#).

DEFAULT must be specified for a column that was defined as GENERATED ALWAYS. A valid value can be specified for a column that was defined as GENERATED BY DEFAULT.

NULL

Specifies the null value as the new value of the column. Specify NULL only for nullable columns.

row-fullselect

Specifies a fullselect that returns a single row. The column values are assigned to each of the corresponding *column-names*. If the fullselect returns no rows, the null value is assigned to each column; an error occurs if any column that is to be updated is not nullable.

If the fullselect refers to columns that are to be updated, the value of such a column in the fullselect is the value of the column in the row before the row is updated.

delete-operation

Specifies the delete operation that is to be executed for the rows where the *matching-condition* evaluates to true.

DELETE

Introduces the delete operation.

insert-operation

Specifies the insert operation that is to be executed for the rows where the *matching-condition* evaluates to true.

INSERT

Specifies a list of column names and row value expressions to use for the insert operation.

The number of values for the row in the row-value expression must be equal to the number of names in the insert column list. The first value is inserted into the first column in the list, the second value into the second column, and so on.

(column-name,...)

Specifies the column for which the insert values are provided. Each name must identify a column of the table or view. The same column must not be identified more than once.

If extended indicators are not enabled, a view column that is not updatable must not be identified. If extended indicator variables are not enabled and the object of the insert operation is a view with non-updatable columns, a list of column names must be specified, and the list must not identify those columns. For an explanation of updatable columns in views, see [“CREATE VIEW statement”](#) on page 1812.

If an included column is not specified in the list of column names, the value of the included column is set to null. The column list cannot contain only included columns.

A view column that cannot accept insert values must not be specified. A value cannot be inserted into a view column that is derived from one of the following items:

- A constant, an expression, or a scalar function
- The same column of the base table as another column of the view

If the object of the operation is a view that contains columns that cannot accept insert values, a list of column names must be specified and the list must not specify these columns.

Omission of the column list is an implicit specification of a list in which every column of the table (that is not defined as implicitly hidden) or view is identified in left-to-right order. This list is established when the statement is prepared and therefore does not include columns that were added to the table after the statement was prepared.

VALUES

Introduces one or more rows of values to insert.

expression

Specifies an expression that does not include a column name of the target. If *expression* is a host variable, the host variable can include an indicator variable, or in the case of a host structure, an indicator array. When extended indicators are enabled, the extended indicator values of DEFAULT (-5) or UNASSIGNED (-7) must not be used if *expression* is more complex than the following references:

- A single column of the source table
- A single host variable
- A host variable that is being explicitly cast

In addition, a CAST specification can be used if either:

- The target column is defined as nullable.
- The target column is defined as NOT NULL with a non-null default, the source of the CAST specification is a single host variable, and the data attributes (data type, length, precision, and scale) of the host variable are the same as the result of the cast specification.

DEFAULT

Specifies the default value for the column. DEFAULT must only be specified for columns that have a default value. The value that is assigned depends on how the column is defined. For more information about default values, see the descriptions of the DEFAULT clause in [“CREATE TABLE statement”](#) on page 1650 and in [“INSERT statement”](#) on page 1996.

If the column is specified in the INCLUDE column list, the column value is set to null.

DEFAULT must be specified for a column that is defined as GENERATED ALWAYS. A valid value can be specified for a column that is defined as GENERATED BY DEFAULT.

NULL

Specifies the null value as the value of the column. Specify NULL only for nullable columns.

signal-statement

Specifies the SIGNAL statement that is to be executed to return an error when the *matching-condition* evaluates to true.

ELSE IGNORE

Specifies that no action is to be taken for the rows where no *matching-condition* evaluates to true. If all rows of *table-reference* are ignored, a warning is returned.

NOT ATOMIC CONTINUE ON SQLEXCEPTION

The rows of input data are processed separately. Any statement level triggers are processed for each row of source data that is processed, and the transition table includes the individual row that was processed. When errors are encountered and this option is in effect, processing continues, and some of the specified rows will not be processed. In this case, if an appropriate trigger is defined on the underlying base table, the statement level trigger will only be activated for rows that were successfully processed.

Regardless of the failure of any particular source row, the MERGE statement will not undo any changes that are made to the database by the statement. Merge will be attempted for rows that follow the failed row. However, the minimum level of atomicity is at least that of a single source row (that is, it is not possible for a partial merge to complete), including any triggers that might have been activated as a result of the MERGE statement.

QUERYNO *integer*

Specifies the number for this SQL statement that is used in EXPLAIN output and trace records. The number is used for the QUERYNO column of the plan table for the rows that contain information about this SQL statement. This number is also used in the QUERYNO column of the SYSIBM.SYSSTMT and SYSIBM.SYSPACKSTMT catalog tables.

If QUERYNO is not specified, the number that is associated with the SQL statement is the statement number that is assigned during precompilation. Thus, if the application program is changed and then precompiled, the statement number might change.

MERGE rules

If *table-reference* is specified:

- More than one *modification-operation* (*update-operation*, *delete-operation*, or *insert-operation*), or *signal-statement* can be specified in a single MERGE statement.
- Each row in the target can only be operated on once. A row in the target can only be identified as MATCHED with one row in the result table of the *table-reference*. A nested SQL operation (RI or trigger except INSTEAD OF trigger) cannot specify the target table (or a table within the same table hierarchy) as a target of an UPDATE, DELETE, INSERT, or MERGE statement.
- A row that is inserted by the MERGE statement cannot also be updated by that MERGE statement. There is no attempt to update a row in the target that did not already exist before the MERGE statement was executed.
- If an error occurs during execution of the MERGE statement, the whole statement is rolled back.

If NOT ATOMIC CONTINUE ON SQLEXCEPTION is specified, or the NOT ATOMIC CONTINUE ON SQLEXCEPTION clause is not specified and *source-values* (VALUES) is specified:

- A MERGE statement can contain one *update-operation* and one *insert-operation*.
- The rows that are updated from a source row are subject to more updates by subsequent source rows in the same statement. The update is cumulative.
- When NOT ATOMIC CONTINUE ON SQLEXCEPTION is specified, the rows of source data are processed separately. Any references to special registers, sequence expressions, and functions in the MERGE statement are evaluated as each row of source data is processed. Statement-level triggers are activated as each row of source data is processed.

- If one or more errors occur during the operation for a row of source data, processing continues. The row that was being processed at the time of the error is not inserted or updated. Execution continues with the next row to be processed, and any other changes that are made during the execution of the multiple-row MERGE statement are not backed out. However, the processing of an individual row is an atomic action.

For other rules that affect the update, insert, or delete portion of the MERGE statement, see the rules section of the corresponding statement description, in the following topics:

- [“INSERT statement” on page 1996](#)
- [“DELETE statement” on page 1853](#)
- [“UPDATE statement” on page 2178](#)

Notes for MERGE

Considerations for the NOT ATOMIC CONTINUE ON SQLEXCEPTION clause

When the NOT ATOMIC CONTINUE ON SQLEXCEPTION clause is specified, or the NOT ATOMIC CONTINUE ON SQLEXCEPTION clause is not specified and *source-values* (VALUES) is specified, the following clauses must not be specified:

- *table-reference*
- *correlation-clause* that contains a list of column names
- AND *search-condition*
- *delete-operation*
- SIGNAL
- ELSE IGNORE
- *row-fullselect*

In addition:

- The WHEN MATCHED clause must not be specified more than one time.
- The WHEN NOT MATCHED clause must not be specified more than one time.

Logical order of processing for a not-atomic MERGE statement

For a not-atomic MERGE statement (a MERGE statement that includes the NOT ATOMIC CONTINUE ON SQLEXCEPTION clause, or the NOT ATOMIC CONTINUE ON SQLEXCEPTION clause is not specified and *source-values* (VALUES) is specified), each source row is processed independently, as if a separate MERGE statement were executed for each source row. For example, a source row that causes an update of a target row activates any triggers (including statement-level triggers) when the update of the row is performed. Thus, if five rows are updated, any update triggers (including statement-level update triggers) are activated five times.

For a not-atomic MERGE statement, the logical order of processing for each row is:

1. Determine the row that is to be processed from the source and target.
2. Use the ON clause to classify these rows as either MATCHED or NOT MATCHED.
3. Evaluate any expression in any *assignment-clause* and *insert-operation*.
4. Apply the *modification-operation* to the applicable row. The triggers that are activated by the *modification-operation* are executed for the *modification-operation*. Statement-level triggers are activated even if no rows satisfy the *modification-operation*.

Logical order of processing for an atomic MERGE statement

For an atomic MERGE statement (the NOT ATOMIC CONTINUE ON SQLEXCEPTION clause is not specified), the source rows are processed as if a set of rows is processed by each WHEN clause. Thus, if five rows are updated, any row-level update triggers are activated five times. In addition, n statement-level update triggers are activated, where n is the number of WHEN clauses that contain

an UPDATE, including any WHEN clauses that contain an UPDATE that did not process any of the source rows.

For an atomic MERGE, the logical order of processing is:

1. Determine the set of rows that are to be processed from the source and target. If any of the special registers CURRENT DATE, CURRENT TIME, or CURRENT TIMESTAMP are used in this statement, only one clock reading is done for the whole statement.
2. Use the ON clause to classify these rows as either MATCHED or NOT MATCHED.
3. Evaluate any *matching-condition* in the WHEN clauses.
4. Evaluate any expression in any *assignment-clause* and *insert-operation*.
5. Execute each *signal-statement*.
6. Apply each *modification-operation* to the applicable rows in the order of specification. The triggers that are activated by each *modification-operation* are executed for the *modification-operation*. Statement-level triggers are activated even if no rows satisfy the *modification-operation*. Each *modification-operation* can affect the triggers and referential constraints of each subsequent *modification-operation*.

Trigger considerations

A MERGE statement might cause triggers to be activated. A trigger might cause other statements to be executed or raise error conditions depending on the source data values. A before-update or before-insert trigger processes immediately before the update or insert operation.

If a source row results in an insert, any after-insert triggers are activated after the insert operation completes.

If a source row results in updates, any after-update triggers are activated after all of the update operations complete.

If a source row results in deletes, any after-delete triggers are activated after all of the delete operations complete.

Number of rows updated

After a MERGE statement is executed, the ROW_COUNT statement information item in the SQL Diagnostics Area (or SQLERRD(3) of the SQLCA) is the number of rows that are operated on by the MERGE statement, excluding rows that are identified by the ELSE IGNORE clause. The ROW_COUNT item and SQLERRD(3) do not include the number of rows that were operated on as a result of triggers.

For a description of ROW_COUNT, see “GET DIAGNOSTICS statement” on page 1949. For a description of the SQLCA, see [Appendix F, “SQL communication area \(SQLCA\),”](#) on page 2303.

SQLCA and GET DIAGNOSTICS considerations

The GET DIAGNOSTICS statement can be used immediately after the MERGE statement to check which input rows fail during the merge operation. The GET DIAGNOSTICS statement information item, NUMBER, indicates the number of conditions that are raised. The GET DIAGNOSTICS condition information item, DB2_ROW_NUMBER, indicates the input source rows that cause an error.

Considerations for a MERGE without a column list in insert-operation

A MERGE statement without a specified column list as part of *insert-operation* does not include implicitly hidden columns. Therefore, such columns must have a defined default value.

DRDA considerations when NOT ATOMIC CONTINUE ON SQLEXCEPTION is specified (or the NOT ATOMIC CONTINUE ON SQLEXCEPTION clause is not specified and source-values (VALUES) is specified)

Db2 Connect Version 9.1 and subsequent releases support the MERGE statement. The support is for CLI only, with no embedded static SQL support.

When you run a MERGE statement at a Db2 for z/OS requester, cases might exist where the requester does not know the number of rows in the source table. This situation includes the following cases:

- For static or dynamic MERGE statements, of the FOR *n* ROWS clause contains a constant value for *n*.

- For dynamic MERGE statements, of host variables are specified on the USING clause of an EXECUTE statement.

For both of these cases, if the number of rows in the source table is not known, the requester might send more data than is required to the server. The number of rows that are processed is correct because the server knows the correct numbers of rows to process. However, performance might be adversely affected. Consider the following example:

```

...long serial num [10];
struct { short len;
char data [18];
}
name[20]...
EXEC SQL
MERGE INTO T1
  USING (VALUES (:serial_num, :name))
  FOR 5 ROWS...

```

When this statement is run at the requester, the number of rows to merge (five) is not known. As a result, the requester sends 10 values for `serial - name` and `name` to the server because 10 is the size of the smallest host-variable array and is, therefore, the maximum number of rows that can merge without causing an error.

Do the following to help minimize performance problems:

- Avoid using numeric constants in the FOR *n* ROWS clause of the MERGE statement. For static MERGE statements, avoiding numeric constants ensures that the values for *n* are known at the requester.
- For dynamic MERGE statements, use the USING DESCRIPTOR clause instead of the USING *host-variable* clause on the EXECUTE statement. If a USING DESCRIPTOR clause is used on the EXECUTE statement, the value for *n* must be indicated in the descriptor.
- If either of the previous methods cannot be used, perform the following actions:
 - Make your host-variable arrays as small as possible, or declare that the size of your host-variable arrays are the size of *n* in the descriptor. This action avoids sending many unused host-variable array entries to the server.
 - Ensure that varying length string arrays are initialized to a length of 0 (zero). Doing so minimizes the amount of data that is sent to the server.
 - Ensure that decimal host-variable arrays are initialized to valid values. Doing so causes the requester to avoid sending a negative SQLCODE if the requester encounters invalid decimal data.

Extended indicators usage

When extended indicators are enabled, indicator values other than positive values and 0 (zero) through -7 must not be specified. The DEFAULT and UNASSIGNED extended indicator values must not appear in contexts where they are not supported.

Extended indicators

In an update operation of the MERGE statement:

- An extended indicator value of UNASSIGNED has the same effect as if it had not been specified in the statement.
- An extended indicator value of DEFAULT must not be specified for a row-begin, row-end, transaction-start-ID, or generated expression column.
- An extended indicator value of UNASSIGNED must not be assigned to all of the target columns.

In an insert operation of the MERGE statement, an extended indicator value of UNASSIGNED has the effect of setting the column to its default value.

Extended indicators and update triggers

If a target column is assigned an extended indicator value of unassigned, that column is not considered to have been updated. That column is treated as if it had not been specified in the OF *column-name* list of any update trigger that is defined on the target table.

Extended indicators and insert triggers

The activation of insert triggers is not affected by the use of extended indicator variables. Suppose that all columns in the implicit or explicit column list are assigned an extended indicator value of unassigned or default. Then, assume that an insert operation where all columns are assigned to the respective default values is attempted. If that operation is successful, the insert trigger is activated.

Table space data compression during an insert operation

If the table space is defined with compression, and data is inserted into a table in the table space, the first rows are stored uncompressed. When a amount of data that is determined by Db2 is inserted into the table, a compression dictionary is created and stored in the table space. The rows that are inserted into the table after the dictionary is created are stored compressed by using the compression dictionary.

System-period temporal tables

When a MERGE statement is processed for a system-period temporal table, the rows are affected in the same way as if the specific data change operation was invoked.

Archive-enabled tables

Consider the case when the target of a MERGE statement is an archive-enabled table, and the merge operation includes an insert or update operation. In this case, the involved rows are affected in the same way as if the insert or update operation was directly invoked on the table.

Tables with enforced row and column access controls

For information about how enabled row permissions and column masks affect the update and insert operations in the MERGE statement, see the INSERT and UPDATE statement information.

Examples for MERGE

Example 1

For activities whose description has been changed, update the description in the RECORDS table. For new activities, insert into the RECORDS table. The RECORDS and ACTIVITIES tables both have ACTIVITY as a primary key.

```
MERGE INTO RECORDS AR
  USING (SELECT ACTIVITY, DESCRIPTION FROM ACTIVITIES) AC
  ON (AR.ACTIVITY = AC.ACTIVITY)
  WHEN MATCHED THEN
    UPDATE SET
      DESCRIPTION = AC.DESCRPTION
  WHEN NOT MATCHED THEN
    INSERT
      (ACTIVITY, DESCRIPTION)
    VALUES (AC.ACTIVITY, AC.DESCRPTION);
```

Example 2

Using the SHIPMENT table, merge rows into the INVENTORY table: Increase the quantity by the part count in the SHIPMENT table for rows that match; else insert a row for the new part number into the inventory table.

```
MERGE INTO INVENTORY AS IN
  USING (SELECT PARTNO, DESCRIPTION, COUNT FROM SHIPMENT
  WHERE SHIPMENT.PARTNO IS NOT NULL) AS SH
  ON (IN.PARTNO = SH.PARTNO)
  WHEN MATCHED THEN
    UPDATE SET
      DESCRIPTION = SH.DESCRPTION,
      QUANTITY = IN.QUANTITY + SH.COUNT
  WHEN NOT MATCHED THEN
    INSERT
      (PARTNO, DESCRIPTION, QUANTITY)
    VALUES (SH.PARTNO, SH.DESCRPTION, SH.COUNT);
```

Example 3

Using the TRANSACTION table, merge rows into the ACCOUNT table: Update the balance from the set of transactions against an account ID, and insert new accounts from the consolidated transactions where they do not already exist.

```

MERGE INTO ACCOUNT AS A
  USING (SELECT ID, SUM(AMOUNT) SUM_AMOUNT FROM TRANSACTION
        GROUP BY ID) AS T
  ON A.ID = T.ID
  WHEN MATCHED THEN
    UPDATE SET
      BALANCE = A.BALANCE + T.SUM_AMOUNT
  WHEN NOT MATCHED THEN
    INSERT
      (ID, BALANCE)
    VALUES (T.ID, T.SUM_AMOUNT);

```

Example 4

Using the TRANSACTION_LOG table, merge rows into the EMPLOYEE_FILE table: Update the phone and office with the latest TRANSACTION_LOG row based on the transaction time, and insert the latest new EMPLOYEE_FILE row where the row does not already exist.

```

MERGE INTO EMPLOYEE_FILE AS E
  USING (SELECT EMPID, PHONE, OFFICE
        FROM (SELECT EMPID, PHONE, OFFICE,
                    ROW_NUMBER() OVER (PARTITION BY EMPID
                                       ORDER BY TRANSACTION_TIME DESC) RN
        FROM TRANSACTION_LOG) AS NT
        WHERE RN = 1) AS T
  ON E.EMPID = T.EMPID
  WHEN MATCHED THEN
    UPDATE SET
      (PHONE, OFFICE) =
      (T.PHONE, T.OFFICE)
  WHEN NOT MATCHED THEN
    INSERT
      (EMPID, PHONE, OFFICE)
    VALUES (T.EMPID, T.PHONE, T.OFFICE);

```

Example 5

Update the list of activities organized by Group A in the RECORDS table. Delete all outdated activities and update the activities information (DESCRIPTION and DATE) in the RECORDS table if they have been changed. For new upcoming activities, insert into the RECORDS table. Signal an error if the date of the activity is not known. The date of the activities in the RECORDS table must be specified. Each group has an activities table. For example, ACTIVITIES_GROUPA contains all activities that group A organizes, and the RECORDS table contains all upcoming activities organized by different groups in a company. The RECORDS table has (GROUP, ACTIVITY) as the primary key, and DATE is not nullable. All activities tables have ACTIVITY as the primary key. The LAST_MODIFIED column in the RECORDS table is defined with CURRENT_TIMESTAMP as the default value.

```

MERGE INTO RECORDS AR
  USING (SELECT ACTIVITY, DESCRIPTION, DATE, LAST_MODIFIED
        FROM ACTIVITIES_GROUPA) AC
  ON (AR.ACTIVITY = AC.ACTIVITY) AND AR.GROUP = 'A'
  WHEN MATCHED AND AC.DATE IS NULL THEN
    SIGNAL SQLSTATE '70001'
    SET MESSAGE_TEXT =
      AC.ACTIVITY CONCAT ' CANNOT BE MODIFIED. REASON: DATE IS NOT KNOWN'
  WHEN MATCHED AND AC.DATE < CURRENT_DATE THEN
    DELETE
  WHEN MATCHED AND AR.LAST_MODIFIED < AC.LAST_MODIFIED THEN
    UPDATE SET
      (DESCRIPTION, DATE, LAST_MODIFIED) = (AC.DESCRPTION, AC.DATE, DEFAULT)
  WHEN NOT MATCHED AND AC.DATE IS NULL THEN
    SIGNAL SQLSTATE '70002'
    SET MESSAGE_TEXT =
      AC.ACTIVITY CONCAT ' CANNOT BE INSERTED. REASON: DATE IS NOT KNOWN'
  WHEN NOT MATCHED AND AC.DATE >= CURRENT_DATE THEN
    INSERT
      (GROUP, ACTIVITY, DESCRIPTION, DATE)
    VALUES ('A', AC.ACTIVITY, AC.DESCRPTION, AC.DATE)
  ELSE IGNORE;

```

Example 6

Update the descriptions for activities that exist in the RECORDS table. Otherwise, insert the activity and its description into the RECORDS table.

```

MERGE INTO RECORDS AR
  USING (VALUES (:hv_activity, :hv_description)
        FOR :hv_nrows ROWS)
    AS AC (ACTIVITY, DESCRIPTION)
  ON (AR.ACTIVITY = AC.ACTIVITY)
  WHEN MATCHED THEN UPDATE SET DESCRIPTION = AC.DESCRPTION
  WHEN NOT MATCHED THEN INSERT (ACTIVITY, DESCRIPTION)
    VALUES (AC.ACTIVITY, AC.DESCRPTION)
  NOT ATOMIC CONTINUE ON SQLEXCEPTION;

```

Example 7

Use the transaction data to merge rows into the account table. Update the balance from the transaction data against an account ID and insert new accounts from the transaction data where the accounts do not already exist.

```

MERGE INTO ACCOUNT AS A
  USING (VALUES (:hv_id, :hv_amount)
        FOR 3 ROWS)
    AS T (ID, AMOUNT)
  ON (A.ID = T.ID)
  WHEN MATCHED THEN UPDATE SET BALANCE = A.BALANCE + T.AMOUNT
  WHEN NOT MATCHED THEN INSERT (ID, BALANCE)
    VALUES (T.ID, T.AMOUNT)
  NOT ATOMIC CONTINUE ON SQLEXCEPTION;

```

Example 8

Update the list of activities that are organized by group A in the RECORDS table. Update the activities information (description and date when last modified) in the RECORDS table if the activities exist in the RECORDS table and are also organized by group A. Insert new activities into the RECORDS table.

```

-- hv_nrows = 3
-- hv_activity(1) = 'D'; hv_description(1) = 'Dance'; hv_date(1) = '03/01/07'
-- hv_activity(2) = 'S'; hv_description(2) = 'Singing'; hv_date(2) = '03/17/07'
-- hv_activity(3) = 'T'; hv_description(3) = 'Tai-chi'; hv_date(3) = '05/01/07'
-- hv_group = 'A';
-- note that hv_group is not an array. All 3 values contain the same values
MERGE INTO RECORDS AR
  USING (VALUES (:hv_activity, :hv_description, :hv_date, :hv_group)
        FOR :hv_nrows ROWS)
    AS AC (ACTIVITY, DESCRIPTION, DATE, GROUP)
  ON AR.ACTIVITY = AC.ACTIVITY AND AR.GROUP = AC.GROUP
  WHEN MATCHED
  THEN UPDATE SET (DESCRIPTION, DATE, LAST_MODIFIED)
    = (AC.DESCRPTION, AC.DATE, CURRENT_TIMESTAMP)
  WHEN NOT MATCHED
  THEN INSERT (GROUP, ACTIVITY, DESCRIPTION, DATE, LAST_MODIFIED)
    VALUES (AC.GROUP, AC.ACTIVITY, AC.DESCRPTION, AC.DATE, CURRENT_TIMESTAMP)
  NOT ATOMIC CONTINUE ON SQLEXCEPTION;

```

Example 9

Use two arrays, CHARA and INTA, as input to a MERGE statement. Column COL2 is set to the cardinality of CHARA for matching rows, and COL2 is set to the cardinality of INTA for non-matching rows.

```

CREATE TYPE INTARRAY AS INTEGER ARRAY[6];
CREATE TYPE CHARARRAY AS CHAR(20) ARRAY[7];
CREATE VARIABLE INTA AS INTARRAY;
CREATE VARIABLE CHARA AS CHARARRAY;
CREATE VARIABLE SI INT;
SET CHARA = ARRAY['a', 'b', 'c'];
SET INTA = ARRAY [1, 2, 3, 4, 5];
CREATE TABLE T1 (COL1 CHAR(7), COL2 INT);
INSERT INTO T1 VALUES ('abc', 10);
MERGE INTO T1 AS A
  USING TABLE (VALUES ('rsk', 3) ) AS T (ID, AMOUNT)
  ON A.COL1 = T.ID
  WHEN MATCHED
  THEN UPDATE SET COL2 = CARDINALITY(CHARA)
  WHEN NOT MATCHED
  THEN INSERT (COL1, COL2 ) VALUES (T.ID, CARDINALITY(INTA));

```

OPEN statement

The OPEN statement opens a cursor so that it can be used to process rows from its result table.

Invocation for OPEN

This statement can only be embedded in an application program. It is an executable statement that cannot be dynamically prepared. It must not be specified in Java.

Authorization for OPEN

See “[DECLARE CURSOR statement](#)” on page 1819 for the authorization required to use a cursor.

Syntax for OPEN

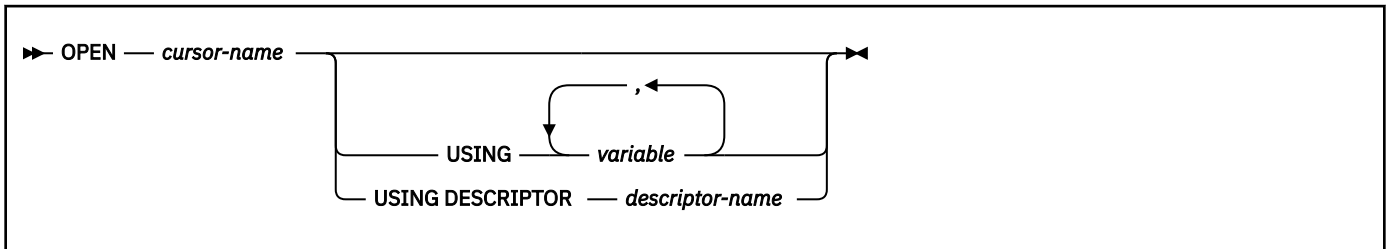
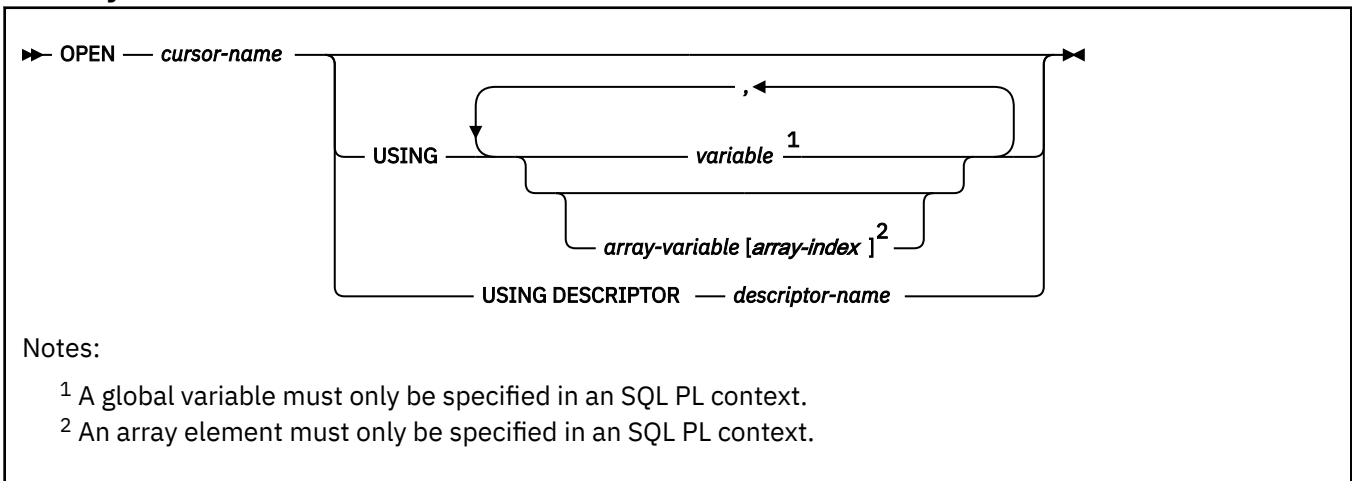

Description for OPEN

cursor-name

Identifies the cursor to be opened. The *cursor-name* must identify a declared cursor as explained in “[DECLARE CURSOR statement](#)” on page 1819. When the OPEN statement is executed, the cursor must be in the closed state.

The SELECT statement of the cursor is either one of the following types of SELECT statements:

- The *select-statement* that is specified in the DECLARE CURSOR statement
- The prepared *select-statement* that is identified by the *statement-name* that is specified in the DECLARE CURSOR statement.

If the statement has not been successfully prepared, or is not a *select-statement*, the cursor cannot be successfully opened.

The result table of the cursor is derived by evaluating the SELECT statement. The evaluation uses the current values of any special registers or PREVIOUS VALUE expressions that are specified in the SELECT statement, and the current values of any host variables that are specified in the SELECT

statement or the USING clause of the OPEN statement. The rows of the result table can be derived during the execution of the OPEN statement, and a temporary copy of a result table can be created to hold those rows. They can be derived during the execution of later FETCH statements. In either case, the cursor is placed in the open state and positioned before the first row of its result table.

If the table is empty, the position of the cursor is effectively “after the last row.” The Db2 system does not indicate an empty table when the OPEN statement is executed. A subsequent fetch for the cursor might return the SQLSTATE warning of '02000'.

USING

Introduces a list of variables or array element expressions whose values are substituted for the parameter markers (question marks) in the statement of the cursor, depending on the declaration of the cursor:

- If the DECLARE CURSOR statement included *statement-name*, the statement was prepared with a PREPARE statement. The variables specified in the USING clause of the OPEN statement replace any parameter markers in the prepared statement. This reflects the typical use of the USING clause of the OPEN statement. For an explanation of parameter marker replacement, see “[PREPARE statement](#)” on page 2042.

If the prepared statement includes parameter markers, you must use USING. If the prepared statement does not include parameter markers, USING is ignored.

- If the DECLARE CURSOR statement included *select-statement* and the SELECT statement included variables, the USING clause of the OPEN statement can be used to specify variables that are to override the values that were specified when the cursor was defined. In this case, the OPEN statement is executed as if each variable in the SELECT statement were a parameter marker except that the attributes of the target variable are the same as the variables in the SELECT statement. The effect is to override the values of the variables in the SELECT statement of the cursor with the values of the variables specified in the USING clause. The overriding value is always the value of the main variable because indicator variables are ignored in this context without warning.

The *n*th variable corresponds to the *n*th parameter marker in the prepared statement. Where appropriate, locator variables and file reference variables can be provided as the source of values for parameter markers.

variable

Identifies a variable or a host structure that is declared in the application program in accordance with the rules for declaring variables and host structures. When the statement is executed, a reference to a structure is replaced by a reference to each of its variables. The number of variables must be the same as the number of parameter markers in the prepared statement.

An array global variable must only be specified if the OPEN statement is issued in SQL PL.

array-variable [array-index]

Identifies an array element. An array element must only be specified if the OPEN statement is issued in SQL PL.

array-variable

Specifies an array variable.

[array-index]

An expression that specifies which element in the array to use.

For an ordinary array, the array index expression must be castable to INTEGER, and must not be the null value. The index value must be between 1 and the maximum cardinality that is defined for the array.

For an associative array, the array index expression must be castable to the index data type of the associative array, and must not be the null value.

array-index must not be:

- An expression that references the CURRENT DATE, CURRENT TIME, or CURRENT TIMESTAMP special register

- A nondeterministic function
- A function that is defined with EXTERNAL ACTION
- A function that is defined with MODIFIES SQL DATA
- A sequence expression

DESCRIPTOR *descriptor-name*

Identifies an SQLDA that contains a valid description of the input host variables.

Before the OPEN statement is processed, the user must set the following fields in the SQLDA:

- SQLLN to indicate the number of SQLVAR occurrences provided in the SQLDA
A REXX SQLDA does not contain this field.
- SQLABC to indicate the number of bytes of storage allocated for the SQLDA
- SQLD to indicate the number of variables used in the SQLDA when processing the statement
- SQLVAR occurrences to indicate the attributes of the variables

The SQLDA must have enough storage to contain all SQLVAR occurrences. If LOBs or distinct types are present in the result table, there must be additional SQLVAR entries for each input host variable. For more information on the SQLDA, which includes a description of the SQLVAR and an explanation on how to determine the number of SQLVAR occurrences, see [Appendix G, “SQL descriptor area \(SQLDA\),” on page 2313](#).

SQLD must be set to a value greater than or equal to zero and less than or equal to SQLLN. It must be the same as the number of parameter markers in the prepared statement.

See [“Identifying an SQLDA in C or C++” on page 2329](#) for how to represent *descriptor-name* in C.

Notes for OPEN

Errors occurring on OPEN: In local and remote processing, the DEFER(PREPARE) and REOPT(ALWAYS)/REOPT(ONCE) bind options can cause some SQL statements to receive "delayed" errors. For example, an OPEN statement might receive an SQLCODE that normally occurs during PREPARE processing. Or a FETCH statement might receive an SQLCODE that normally occurs at OPEN time.

Closed state of cursors: All cursors in an application process are in the closed state when:

- The application process is started.
- A new unit of work is started for the application process unless the WITH HOLD option has been used in the DECLARE CURSOR statement.
- The application was precompiled with the CONNECT(1) option (which implicitly closes any open cursors).

A cursor can also be in the closed state because:

- A CLOSE statement was executed.
- An error was detected that made the position of the cursor unpredictable.

To retrieve rows from the result table of a cursor, you must execute a FETCH statement when the cursor is open. The only way to change the state of a cursor from closed to open is to execute an OPEN statement.

Effect of a temporary copy of a result table: Db2 can process a cursor in two different ways:

- It can create a temporary copy of the result table during the execution of the OPEN statement. You can specify INSENSITIVE SCROLL on the cursor to force the use of a temporary copy of the result table.
- It can derive the result table rows as they are needed during the execution of later FETCH statements.

If the result table is not read-only, Db2 uses the latter method. If the result table is read-only, either method could be used. The results produced by these two methods could differ in the following respects:

When a temporary copy of the result table is used: An error can occur that would otherwise not occur until some later FETCH statement. Insert operations that are executed while the cursor is open cannot affect the result table once all the rows have been materialized in the temporary copy of the result table. For a scrollable insensitive cursor, update and delete operations that are executed while the cursor is open cannot affect the result table. For a scrollable sensitive static cursor, update and delete operations can affect the result table if the rows are subsequently fetched with sensitive FETCH statements.

When a temporary copy of the result table is not used: Insert, update, and delete operations that are executed while the cursor is open can affect the result table. The effect of such operations is not always predictable.

For example, if cursor C is positioned on a row of its result table defined as SELECT * FROM T, and you insert a row into T, the effect of that insert on the result table is not predictable because its rows are not ordered. A later FETCH C might or might not retrieve the new row of T. To avoid these changes, you can specify INSENSITIVE SCROLL for the cursor to force the use of a temporary copy of the result table.

Parameter marker replacement: Before the OPEN statement is executed, each parameter marker in the query is effectively replaced by its corresponding host variable. The replacement is an assignment operation in which the source is the value of the host variable and the target is a variable within Db2. The assignment rules are those described for assignment to a column in [“Assignment and comparison”](#) on page 143. For a typed parameter marker, the attributes of the target variable are those specified by the CAST specification. For an untyped parameter marker, the attributes of the target variable are determined according to the context of the parameter marker. For the rules that affect parameter markers, see [Parameter markers](#).

Let V denote a host variable that corresponds to parameter marker P. The value of V is assigned to the target variable for P in accordance with the rules for assigning a value to a column:

- V must be compatible with the target.
- If V is a string, its length (excluding trailing blanks) must not be greater than the length attribute of the target.
- If V is a number, the absolute value of its integral part must not be greater than the maximum absolute value of the integral part of the target.
- If the attributes of V are not identical to the attributes of the target, the value is converted to conform to the attributes of the target.
- If the target cannot contain nulls, V must not be null.

When the SELECT statement of the cursor is evaluated, each parameter marker in the statement is effectively replaced by the value of its corresponding host variable. For example, if V is CHAR(6) and the target is CHAR(8), the value used in place of P is the value of V padded on the right with two blanks. For more on the process of replacement, see [Parameter marker replacement](#).

Considerations for scrollable cursors: Following an OPEN *cursor* statement, a GET DIAGNOSTICS statement can be used to get the attributes of the cursor such as the following information (for more information, see [“GET DIAGNOSTICS statement”](#) on page 1949):

- DB2_SQL_ATTR_CURSOR_HOLD. Whether the cursor was defined with the WITH HOLD attribute.
- DB2_SQL_ATTR_CURSOR_SCROLLABLE. Scrollability of the cursor.
- DB2_SQL_ATTR_CURSOR_SENSITIVITY. Effective sensitivity of the cursor.

The sensitivity information can be used by applications (such as an ODBC driver) to determine what type of FETCH (INSENSITIVE or SENSITIVE) to issue for a cursor defined as ASENSITIVE.

- DB2_SQL_ATTR_CURSOR_ROWSET. Whether the cursor can be used to access rowsets.
- DB2_SQL_ATTR_CURSOR_TYPE. Whether a cursor type is forward-only, static, or dynamic.
- The scrollability of the cursor is in SQLWARN1.
- The sensitivity of the cursor is in SQLWARN4.
- The effective capability of the cursor is in SQLWARN5.

Number of rows inserted: SQL data change statements and routines that modify SQL data embedded in the cursor definition are completely executed, and the result table is stored in a temporary table when the cursor opens. If statement execution is successful, the SQLERRD(3) field contains the sum of the number of rows that qualified for insert, update, and delete operations. If an error occurs during execution of an OPEN statement that involves a cursor that contains a data change statement within a fullselect, the results of that data change statement are rolled back.

Materialization of the rows of the result table and NEXT VALUE expressions: If the rows of the result table of a cursor are materialized when the cursor is opened and the SELECT statement of the cursor contains NEXT VALUE expressions, the expressions are processed when the cursor is opened. Otherwise, the NEXT VALUE expressions are evaluated as the rows of the result table are retrieved.

Opening the same cursor multiple times: A cursor in an SQL procedure that is declared as WITH RETURN TO CLIENT can be opened even when a cursor with the same name is already in the open state. In this case, the existing open cursor becomes a result set cursor and is no longer accessible by its cursor name. A new cursor is opened and becomes accessible by the cursor name. Closing the new cursor does not make the cursor that was previously accessible by that name accessible by the cursor name again. Cursors that become result set cursors in this way cannot be accessed at the server and can be processed only at the client.

Examples for OPEN

Example 1: Execute an OPEN statement, which places the cursor at the beginning of the rows to be fetched.

```
EXEC SQL DECLARE C1 CURSOR FOR
  SELECT DEPTNO, DEPTNAME, MGRNO FROM DSN8C10.DEPT
  WHERE ADMRDEPT = 'A00';
EXEC SQL OPEN C1;
DO WHILE (SQLCODE = 0);
  EXEC SQL FETCH C1 INTO :DNUM, :DNAME, :MNUM;
END;
EXEC SQL CLOSE C1;
```

Example 2: Suppose that the following array type, array variable, and table have been defined.

```
CREATE TYPE INTARRAY AS INTEGER ARRAY[100];
CREATE TYPE STRINGARRAY AS VARCHAR(10) ARRAY[100];
CREATE TABLE T1 (COL1 CHAR(10), COL2 INT);
```

Use an array variable as input for a dynamic SQL statement. The dynamic statement references an array element in the array variable. The dynamic statement contains two parameter markers, one for the array variable and one for the index of the array element. The OPEN statement provides two input values in the USING clause: the array variable, and a variable that contains the index for the array element.

```
CREATE PROCEDURE PROCESSPERSONS (OUT WITHO STRINGARRAY, INOUT INTO INT)
BEGIN
  DECLARE INTA INTARRAY;
  DECLARE INTB INTARRAY;
  DECLARE INTV INTEGER;
  DECLARE STMT CHAR(100);
  DECLARE C2 CURSOR FOR S1;
  --
  -- Initialize the array
  --
  SET INTA = ARRAY[1,INTEGER(2),3+0,4,5,6] ;
  --
  -- Use dynamic SQL with an array parameter marker and a parameter marker
  -- containing the index to retrieve the value from the array parameter.
  -- The array is referenced in a predicate.
  --
  SET STMT = 'SELECT COL1 FROM T1 WHERE COL2 = CAST(? AS INTARRAY)[?]';
  PREPARE S1 FROM STMT;
  OPEN C2 USING INTA, INTV; -- Input: INTA is an array, and INTV is the
  -- index for the array element
  FETCH C2 INTO INTB ; -- Output: INTB is an array variable
  ...

```

```
CLOSE C2;  
...  
END
```

PREPARE statement

The PREPARE statement creates an executable SQL statement from a string form of the statement. The character-string form is called a *statement string*. The executable form is called a *prepared statement*.

Invocation for PREPARE

This statement can only be embedded in an application program. It is an executable statement that cannot be dynamically prepared. It must not be specified in Java.

Authorization for PREPARE

The authorization rules are those defined for the dynamic preparation of the SQL statement specified by the PREPARE statement. For example, see Chapter 6, “Queries,” on page 1007 for the authorization rules that apply when a SELECT statement is prepared.

The statement that is prepared using only the EXPLAIN privilege cannot be executed, and only the descriptive information can be obtained for that statement.

Syntax for PREPARE

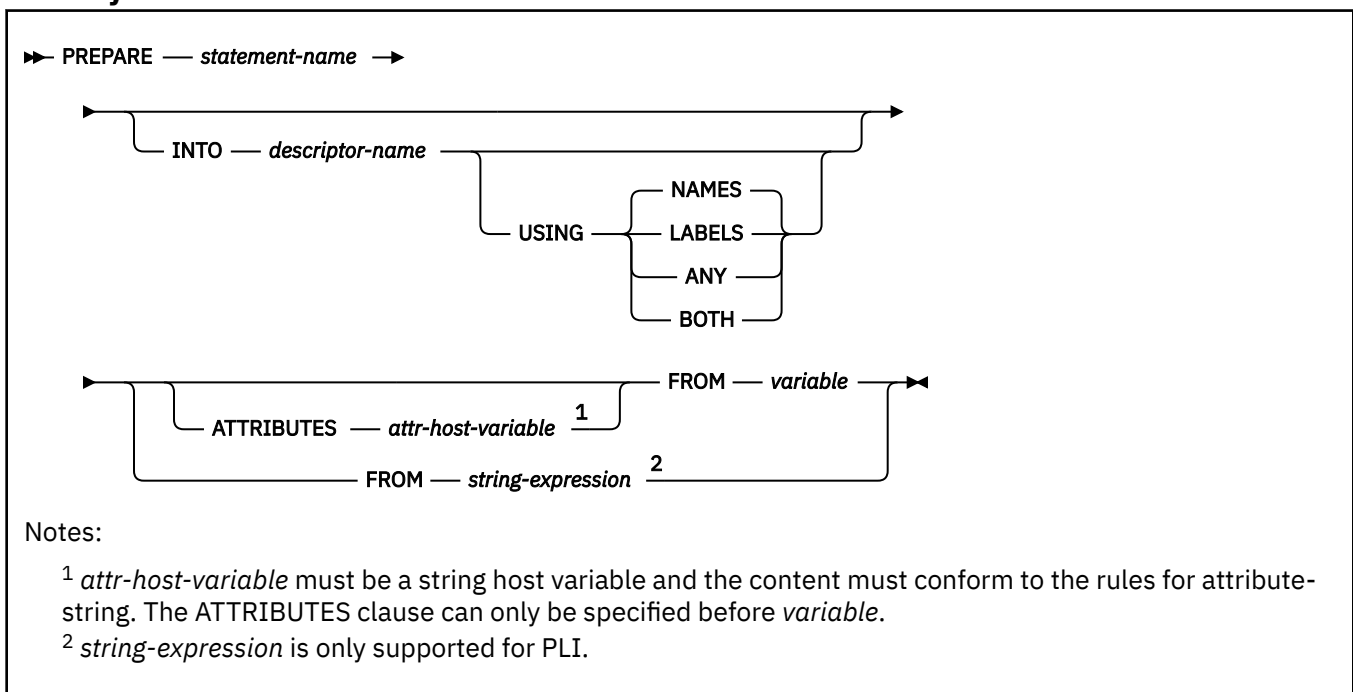

attribute-string

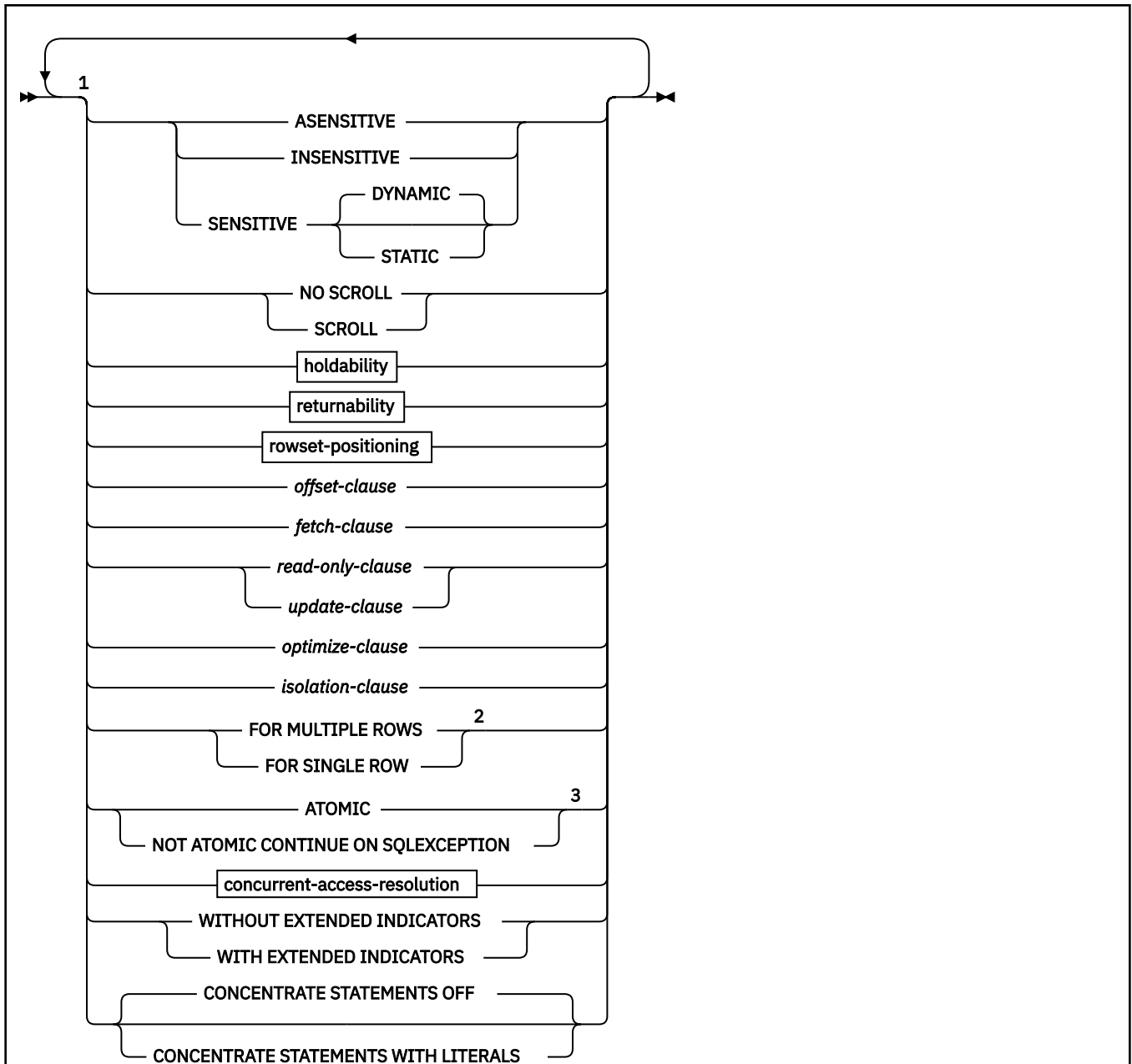

Notes:

- 1 The same clause must not be specified more than one time. If the options are not specified, their defaults are whatever was specified for the corresponding option in an associated statement.
- 2 The FOR SINGLE ROW or FOR MULTIPLE ROWS clause must only be specified for an INSERT or a MERGE statement.
- 3 The ATOMIC or NOT ATOMIC CONTINUE ON SQLEXCEPTION clause must only be specified for an INSERT statement.

holdability:

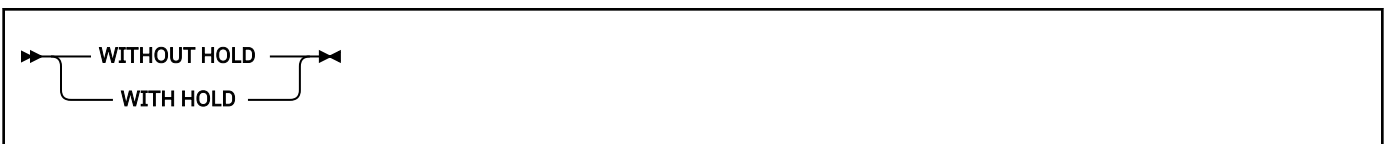

returnability:



rowset-positioning:

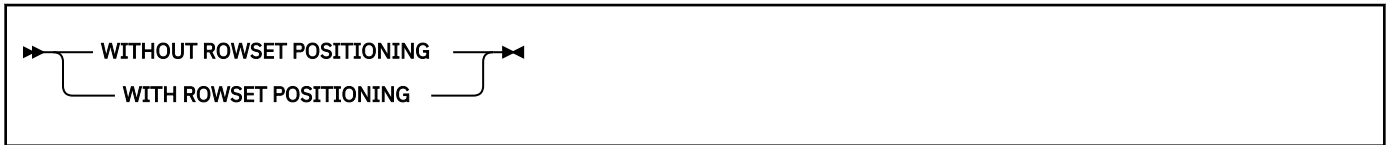

concurrent-access-resolution



Description for PREPARE

statement-name

Names the prepared statement. If the name identifies an existing prepared statement, that prepared statement is destroyed. The name must not identify a prepared statement that is the SELECT statement of an open cursor.

INTO

If you use INTO, and the PREPARE statement is successfully executed, information about the prepared statement is placed in the SQLDA specified by the descriptor name. Thus, the PREPARE statement:

```
EXEC SQL PREPARE S1 INTO :SQLDA FROM :V1;
```

is equivalent to:

```
EXEC SQL PREPARE S1 FROM :V1;
EXEC SQL DESCRIBE S1 INTO :SQLDA;
```

descriptor-name

Identifies the SQLDA. For languages other than REXX, SQLN must be set to indicate the number of SQLVAR occurrences. See “DESCRIBE statement” on page 1869 for information about how to determine the number of SQLVAR occurrences to use and for an explanation of the information that is placed in the SQLDA.

See “Identifying an SQLDA in C or C++” on page 2329 for how to represent *descriptor-name* in C.

USING

Indicates what value to assign to each SQLNAME variable in the SQLDA when INTO is used. If the requested value does not exist, SQLNAME is set to length 0.

NAMES

Assigns the name of the column. This is the default.

LABELS

Assigns the label of the column. (Column labels are defined by the LABEL statement.)

ANY

Assigns the label of the column. If the column has no label or the label is a string of length 0, the column name is used instead.

BOTH

Assigns both the label and name of the column. In this case, two or three occurrences of SQLVAR per column, depending on whether the result table contains distinct types, are needed to accommodate the additional information. To specify this expansion of the SQLVAR array, set SQLN to $2 \times n$ or $3 \times n$, where n is the number of columns in the object being described. For each of the columns, the first n occurrences of SQLVAR, which are the base SQLVAR entries, contain the column names. Either the second or third n occurrences of SQLVAR, which are the extended SQLVAR entries, contain the column labels. If there are no distinct types, the labels are returned in the second set of SQLVAR entries. Otherwise, the labels are returned in the third set of SQLVAR entries.

A REXX SQLDA does not include the SQLN field, so you do not need to set SQLN for REXX programs.

ATTRIBUTES *attr-host-variable*

Specifies the attributes that are in effect if a corresponding attribute has not been specified as part of the associated statement. If attributes are specified as part of the associated statement, they are used instead of the corresponding attributes specified on the PREPARE statement. In turn, if attributes are specified in the PREPARE of a SELECT statement, they are used instead of the corresponding attributes specified on a DECLARE CURSOR statement.

attr-host-variable must identify a host variable that is described in the program in accordance with the rules for declaring string variables. *attr-host-variable* must be a string variable (either fixed-length or varying-length) that has a length attribute that does not exceed 32758 bytes. Leading and trailing blanks are removed from the value of the host variable. The host variable must contain a valid *attribute-string*.

An indicator variable can be used to indicate whether or not attributes are actually provided on the PREPARE statement. Thus, applications can use the same PREPARE statement regardless of whether attributes need to be specified or not.

The options that can be specified as part of the *attribute-string* are as follows:

ASENSITIVE, INSENSITIVE, SENSITIVE STATIC, or SENSITIVE DYNAMIC

Specifies the sensitivity of the cursor to inserts, updates, or deletes that made to the rows underlying the result table. The sensitivity of the cursor determines whether Db2 can materialize the rows of the result into a temporary table. The default is ASENSITIVE.

ASENSITIVE

Specifies that the cursor should be as sensitive as possible. A cursor that defined as ASENSITIVE will be either insensitive or sensitive dynamic; it will not be sensitive static. For information about how the effective sensitivity of the cursor is returned to the application with the GET DIAGNOSTICS statement or in the SQLCA, see [“OPEN statement” on page 2037](#).

The sensitivity of a cursor is a factor in the choice of access path. Explicitly specify the sensitivity level that you need, instead of specifying ASENSITIVE.

INSENSITIVE

Specifies that the cursor does not have sensitivity to inserts, updates, or deletes that are made to the rows underlying the result table. As a result, the size of the result table, the order of the rows, and the values for each row do not change after the cursor is opened. In addition, the cursor is read-only. The SELECT statement or *attribute-string* of the PREPARE statement cannot contain a FOR UPDATE clause, and the cursor cannot be used for positioned updates or deletes.

SENSITIVE

Specifies that the cursor has sensitivity to changes made to the database after the result table is materialized. The cursor is always sensitive to positioned updates and deletes that are made using the same cursor. However, the *select-statement* of the cursor must not contain

³⁶ The scrollability and sensitivity of the cursor are independent and do not have to be specified together. Thus, the cursor might be defined as SCROLL INSENSITIVE, but the PREPARE statement might specify SENSITIVE STATIC as an override for the sensitivity.

an SQL data change statement if the cursor is defined as either SENSITIVE DYNAMIC or SENSITIVE STATIC. When the current value of a row no longer satisfies the *select-statement* or *statement-name*, that row is no longer visible through the cursor. When a row of the result table is deleted from the underlying base table, the row is no longer visible through the cursor.

In addition, the cursor has sensitivity to changes made to values outside the cursor (that is, by other cursors or committed changes by other application processes). If Db2 can not make changes made outside the cursor visible to the cursor, an error is issued at OPEN CURSOR. Whether the cursor is sensitive to changes made outside this cursor depends on whether DYNAMIC or STATIC is in effect for the cursor and whether SENSITIVE or INSENSITIVE FETCH statements are used.

Whether the cursor is sensitive to newly inserted rows depends on whether DYNAMIC or STATIC is in effect for the cursor. The default is DYNAMIC.

DYNAMIC

Specifies that the result table of the cursor is dynamic in that the size of the result table can change after the cursor is opened as rows are inserted into or deleted from the underlying table, and the order of the rows can change. Inserts, deletes, and updates that are made by the same application process are immediately visible. Inserts, deletes, and updates that are made by other application processes are visible after they are committed.

All FETCH statements for sensitive dynamic cursors are sensitive to changes made by this cursor, changes made by other cursors in the same application process, and committed changes made by other application processes.

If a SENSITIVE DYNAMIC cursor is not possible, an error is returned. The FETCH FIRST *n* ROWS ONLY clause and the OFFSET clause must not be specified (either in the outermost fullselect for the cursor or as prepare attributes) for a sensitive dynamic cursor.

STATIC

Specifies that the order of the rows and size of the result table is static. The size of the result table does not grow after the cursor is opened and the rows are materialized. The order of the rows is established as the result table is materialized. Rows that are inserted into the underlying table are not added to the result table of the cursor regardless of how the rows were inserted. Rows in the result table do not move if columns in the ORDER BY clause are updated in rows that have already been materialized.

Whether the changes that are made outside the cursor are visible to the cursor depends on the type of FETCH that is used with a SENSITIVE STATIC cursor. For more information, see [Considerations for FETCH statements used with a sensitive static cursor](#).

Using a function that is not deterministic (built-in or user-defined) in the WHERE clause of *select-statement* or *statement-name* of a SENSITIVE STATIC cursor can cause misleading results. This occurs because Db2 constructs a temporary result table and retrieves rows from this table for INSENSITIVE FETCH statements. When Db2 processes a SENSITIVE FETCH statement, rows are fetched from the underlying table and predicates are re-evaluated if they contain non-correlated subqueries. Using a function that is not deterministic can yield a different result for the re-evaluated query causing the row to no longer be considered a match.

If SENSITIVE STATIC is specified and a sensitive static cursor is not possible, then an error is returned.

If ASENSITIVE, INSENSITIVE, SENSITIVE DYNAMIC, or SENSITIVE STATIC is specified as part of the ATTRIBUTES clause, SCROLL must be specified.

SCROLL or NO SCROLL

Specifies whether the cursor is scrollable.

SCROLL

Specifies that the cursor is scrollable.

NO SCROLL

Specifies that the cursor is not scrollable.

WITHOUT RETURN or WITH RETURN

Specifies whether the result table of the cursor is intended to be used as a result set that will be returned from a procedure. If *statement-name* is specified, the default is the corresponding prepare attribute of the statement. Otherwise, the default is WITHOUT RETURN.

WITHOUT RETURN

Specifies that the result table of the cursor is not intended to be used as a result set that will be returned from a procedure.

WITH RETURN

Specifies that the result table of the cursor is intended to be used as a result set that will be returned from a procedure. WITH RETURN is relevant only if the PREPARE statement is contained within the source code for a procedure. In other cases, the precompiler might accept the clause, but it has no effect.

When a cursor that is declared using the WITH RETURN TO CALLER clause remains open at the end of a program or routine, that cursor defines a result set from the program or routine. Use the CLOSE statement to close a cursor that is not intended to be a result set from the program or routine. Although Db2 will automatically close any cursors that are not declared using with a WITH RETURN clause, the use of the CLOSE statement is recommended to increase the portability of applications.

For non-scrollable cursors, the result set consists of all rows from the current cursor position to the end of the result table. For scrollable cursors, the result set consists of all rows of the result table.

TO CALLER

Specifies that the cursor can return a result set to the caller of the procedure. The caller is the program or routine that executed the SQL CALL statement that invokes the procedure that contains the PREPARE statement. For example, if the caller is a procedure, the result set, is returned to the procedure. If the caller is a client application, the result set is returned to the client application.

If the statement is contained within the source code for a procedure, WITH RETURN TO CALLER specifies that the cursor can be used as a result set cursor. A result set cursor is used when the result table of a cursor is to be returned from a procedure. Specifying TO CALLER is optional.

In other cases, the clause is ignored and the cursor cannot be used as a result set cursor.

TO CLIENT

Specifies that the cursor can return a result set to the client application. This cursor is invisible to any intermediate nested procedures. If a function or trigger calls the procedure (either directly or indirectly), the result set cannot be returned to the client and the cursor will be closed after the procedure finishes.

rowset-positioning

Specifies whether rows of data can be accessed as a rowset on a single FETCH statement for this cursor.

WITHOUT ROWSET POSITIONING

Specifies that the cursor can only be used with row positioned FETCH statements.

WITH ROWSET POSITIONING

Specifies that this cursor can be used with rowset positioned or row positioned FETCH statements

offset-clause

The *offset-clause* specifies the number of rows to skip from the beginning of the intermediate result table. *offset-row-count* is a constant that specifies a numeric value that is a positive number or zero. If the value is not BIGINT, the value is cast to a BIGINT value. The offset of the beginning row is zero (not 1). *offset-row-count* must not be the null value.

The *offset-clause* must not be specified for the outermost fullselect for a sensitive dynamic cursor.

For more information, see [“offset-clause” on page 1046](#).

fetch-clause

The *fetch-clause* specifies the maximum number of rows that can be retrieved. *fetch-row-count* is a constant that specifies a numeric value that is a positive number or zero. If the value is not BIGINT, the value is cast to a BIGINT value. *fetch-row-count* must not be the null value.

The *fetch-clause* must not be specified for the outermost fullselect for a sensitive dynamic cursor.

The use of the *fetch-clause* can improve the performance of queries with potentially large result sets when only a limited number of rows are needed. If the clause is specified, the number of rows retrieved will not exceed *n*, where *n* is the value of the integer. An attempt to fetch *n+1* rows is handled the same way as a normal end of data.

For more information, see [“fetch-clause” on page 1047](#).

read-only-clause

Declares that the result table is read-only and therefore the cursor cannot be referred to in positioned UPDATE and DELETE statements.

update-clause

Identifies the columns that can be updated in a later positioned UPDATE statement. Each column must be unqualified and must identify a column of the table or view identified in the first FROM clause of the fullselect. The clause must not be specified if the result table of the fullselect is read-only. The clause must also not be specified if a created temporary table is referenced in the first FROM clause of the select-statement.

If the clause is specified without a list of columns, the columns that can be updated include all the updatable columns of the table or view that is identified in the first FROM clause of the fullselect.

optimize-clause

Requests special optimization of the *select-statement*. If the clause is omitted, optimization is based on the assumption that all rows of the result table will be retrieved. If the clause is specified, optimization is based on the assumption that the number of rows retrieved will not exceed *n*, where *n* is the value of the integer. The clause does not limit the number of rows that can be fetched or affect the result in any way other than performance.

isolation-clause

Specifies the isolation level at which the select statement is executed. See [“isolation-clause” on page 1073](#).

concurrent-access-resolution

Specifies the type concurrent access resolution to use for the select statement. Each clause in *concurrent-access-resolution* can only be specified one time. Only one of the clauses can be specified for each PREPARE statement. If none of the clauses is specified, the locking semantic depends on other attributes of the statement.

SKIP LOCKED DATA

Specifies to skip data on which incompatible locks are held by other transactions. See [“SKIP LOCKED DATA” on page 1076](#).

USE CURRENTLY COMMITTED

Specifies that Db2 can use the currently committed version of the data when the data is in the process of being updated. USE CURRENTLY COMMITTED only applies in the following cases:

- The table that is being accessed is defined in a universal table space
- The access is for a select-statement with an isolation level of cursor stability (CS) or read stability (RS) specified in the isolation-clause:
 - When a read transaction accesses a record that is locked by an insert transaction, both ISOLATION(CS) and ISOLATION(RS) are applicable.
 - When a read transaction accesses a record that is locked by a delete transaction only ISOLATION(CS) is applicable and only when CURRENTDATA(NO) is in effect.

USE CURRENTLY COMMITTED is ignored if used in any other context.

When this clause is specified, the setting of the subsystem parameter EVALUNC applies. If the row qualifies, this clause determines if the row is accessed or skipped.

When this clause is specified and the subsystem parameter SKIPUNCI is in effect, PREPARE uses the specification of this clause. See the Notes section for more information.

When this clause is specified and XML data that does not support multiple XML versions is being selected, Db2 cannot determine whether the data has been committed. In this case, Db2 uses WAIT FOR OUTCOME behavior when accessing the data.

WAIT FOR OUTCOME

Specifies that Db2 waits for the commit or rollback when encountering data that is in the process of being updated or deleted. Rows that are in the process of being inserted are not skipped.

FOR MULTIPLE ROWS or FOR SINGLE ROW

Specifies if a variable number of rows will be provided with host-variable arrays for a dynamic INSERT or MERGE statement.

FOR MULTIPLE ROWS

Specifies that multiple rows can be provided with host-variable arrays on an EXECUTE statement for the statement that is being prepared. FOR MULTIPLE ROWS must only be specified for an INSERT or a MERGE statement.

FOR SINGLE ROW

Specifies that multiple rows must not be provided with host-variable arrays on an EXECUTE statement for the statement that is being prepared. FOR SINGLE ROW must only be specified for an INSERT or a MERGE statement.

ATOMIC or NOT ATOMIC CONTINUE ON SQLEXCEPTION

Specifies if all rows are inserted as an atomic operation. This clause can only be specified for dynamic INSERT statements.

ATOMIC

Specifies that if the insert for any row fails, all changes that are made to the database by any of the inserts, including changes that are made by successful inserts, are undone. This is the default.

NOT ATOMIC CONTINUE ON SQLEXCEPTION

Specifies that, regardless of the failure of any particular insert of a row, the INSERT statement will not undo any changes that are made to the database by the successful inserts of other rows, and inserting will be attempted for subsequent rows. However, the minimum level of atomicity is at least that of a single insert (that is, it is not possible for a partial insert operation to complete), including any triggers that might have been activated as a result of the INSERT statement.

This clause must not be specified if the INSERT statement is contained within a SELECT statement.

For preparing the MERGE statement, atomicity is specified only on the MERGE statement itself.

WITHOUT EXTENDED INDICATORS or WITH EXTENDED INDICATORS

Specifies whether the values that are provided for indicator variables during execution of an INSERT, MERGE, or UPDATE follow standard SQL semantics for indicating NULL values, or can use extended indicator values, including DEFAULT or UNASSIGNED.

WITH EXTENDED INDICATORS is ignored unless the statement is an INSERT statement with a VALUES clause, a MERGE statement, or an UPDATE statement.

CONCENTRATE STATEMENTS OFF or CONCENTRATE STATEMENTS WITH LITERALS

Specifies whether a dynamic SQL statement that specifies literal constants will be cached as a separate unique statement entry in the dynamic statement cache instead of sharing an existing statement in the cache. Dynamic SQL statements are eligible to share an existing statement in the

cache if the new statement meets all of the conditions for sharing a cached version of the same dynamic statement except that the new statement specifies one or more literal constants that are different than the cached statement.

CONCENTRATE STATEMENTS OFF

Specifies that the dynamic SQL statement that specifies literal constants will be cached as a unique statement entry if it specifies one or more constants that are different than the cached version of the same dynamic statement. `CONCENTRATE STATEMENTS OFF` is the default dynamic statement caching behavior.

CONCENTRATE STATEMENTS WITH LITERALS

Specifies that the dynamic SQL statement that specifies literal constants will share a cached version of the same dynamic statement that is also prepared using the `CONCENTRATE STATEMENTS WITH LITERALS` option if the new dynamic statement meets all of the conditions for sharing the cached statement and the constants that are specified can be reused in place of the constants in the cached statement.

FROM

Specifies the statement string. The statement string is the value of the specified *string-expression* or the identified *variable*.

variable

Must identify a variable that is described in the application program in accordance with the rules for declaring string variables. If the source string is over 32KB in length, the *variable* must be a CLOB or DBCLOB variable. The maximum source string length is 2MB although the variable can be declared larger than 2MB. An indicator variable must not be specified with a host variable. In PL/I, COBOL and Assembler language, a host variable must be a varying-length string variable. In C, a host variable must not be a NUL-terminated string. In SQL PL, an SQL variable is used in place of a host variable, and the value must not be null.

string-expression

string-expression is any PL/I expression that yields a string. *string-expression* cannot be preceded by a colon. Variables that are within *string-expression* that include operators or functions should not be preceded by a colon. When *string-expression* is specified, the precompiler-generated structures for *string-expression* use an EBCDIC CCSID and an informational message is returned.

Notes for PREPARE

Rules for statement strings:

The value of the specified *statement-name* is called the *statement string*. The statement string must be one of the following SQL statements:

Statements	Statements
<ul style="list-style-type: none"> • ALLOCATE CURSOR • ALTER • ASSOCIATE LOCATORS • COMMENT • COMMIT • CREATE • DECLARE GLOBAL TEMPORARY TABLE • DELETE • DROP • EXPLAIN • FREE LOCATOR • GRANT 	<ul style="list-style-type: none"> • SET CURRENT APPLICATION COMPATIBILITY • SET CURRENT DEGREE • SET CURRENT DEBUG MODE • SET CURRENT DECFLOAT ROUNDING MODE • SET CURRENT EXPLAIN MODE • SET CURRENT LOCALE LC_CTYPE • SET CURRENT MAINTAINED TABLE TYPES FOR OPTIMIZATION • SET CURRENT OPTIMIZATION HINT • SET CURRENT PRECISION • SET CURRENT QUERY ACCELERATION • SET CURRENT REFRESH AGE

Statements	Statements
<ul style="list-style-type: none"> • HOLD LOCATOR • INSERT • LABEL • LOCK TABLE • MERGE • REFRESH TABLE • RELEASE SAVEPOINT RENAME • REVOKE • ROLLBACK • SAVEPOINT • <i>select-statement</i> • SET <i>assignment-statement</i> • SET CURRENT ACCELERATOR 	<ul style="list-style-type: none"> • SET CURRENT ROUTINE VERSION • SET CURRENT RULES • SET CURRENT SQLID • SET PATH • SET SCHEMA • SET CURRENT TEMPORAL BUSINESS_TIME • SET CURRENT TEMPORAL SYSTEM_TIME • SET SESSION TIME ZONE • SIGNAL • TRANSFER OWNERSHIP • TRUNCATE • UPDATE

The statement string must not have any of the following attributes:

- Begin with EXEC SQL
- End with END-EXEC or a semicolon
- Include references to variables, other than global variables
- Include references to transition variables

Parameter markers:

Although a statement string cannot include references to variables, other than global variables, it can include *parameter markers*. The parameter markers are replaced by the values of variables when the prepared statement is executed. A parameter marker is a question mark (?) that appears where a variable could appear if the statement string were a static SQL statement.

For an explanation of how parameter markers are replaced by values, see the [EXECUTE statement](#), [“OPEN statement” on page 2037](#), and [Dynamically executing a data change statement \(Db2 Application programming and SQL\)](#).

The two types of parameter markers are typed and untyped:

Typed parameter marker

A parameter marker that is specified with its target data type. A typed parameter marker has the general form:

```
CAST(? AS data-type)
```

This invocation of a CAST specification is a "promise" that the data type of the parameter at run time will be of the data type that is specified or some data type that is assignable to the specified data type. For example, in the following UPDATE statement, the value of the argument of the TRANSLATE function will be provided at run time:

```
UPDATE EMPLOYEE
  SET LASTNAME = TRANSLATE(CAST(? AS VARCHAR(12)))
 WHERE EMPNO = ?
```

The data type of the value that is provided for the TRANSLATE function will either be VARCHAR(12), or some data type that can be converted to VARCHAR(12). For more information, refer to [“Assignment and comparison” on page 143](#).

Typed parameter markers can be used in dynamic SQL statements wherever a host variable is supported and the data type is based on the promise made in the CAST specification.

Untyped parameter marker

A parameter marker that is specified without its target data type. An untyped parameter marker has the form of a single question mark. The context in which the parameter marker appears determines its data type. For example, in the above UPDATE statement, the data type of the untyped parameter marker in the predicate is the same as the data type of the EMPNO column.

Untyped parameter markers can be used in dynamic SQL statements in selected locations where variables are supported. These locations and the resulting data type are found in the following tables. The tables group the locations into expressions, predicates, functions, and other statements to help show where untyped parameter markers are allowed. Untyped parameter markers are not supported in other locations.

Expressions

Location of untyped parameter marker	Data type (or error if not supported)
Alone in a select list. For example: SELECT ?	Error
Both operands of a single arithmetic operator, after considering operator precedence and the order of operation rules. Includes cases such as: ? + ? + 10	DECFLOAT(34)
One operand of a single operator in an arithmetic expression (except datetime arithmetic expressions). Includes cases such as: ? + ? * 10	The data type of the other operand
Any operand of a datetime expression. For example: 'timecol + ?' or '? - datecol'	Error
A labeled duration in a datetime expression with a type unit other than SECONDS (the portion of a labeled duration that indicates the type of units cannot be a parameter marker).	DECIMAL(15,0)
A labeled duration in a datetime expression with a type unit of SECONDS (the portion of a labeled duration that indicates the type of units cannot be a parameter marker).	DECIMAL(27,12)
Both operands of a CONCAT operator	Error
One operand of a CONCAT operator when the other operand is any character data type except CLOB	If the other operand is CHAR(<i>n</i>) or VARCHAR(<i>n</i>), where <i>n</i> is less than 128, the data type is VARCHAR(254 - <i>n</i>). In all other cases, the data type is VARCHAR(254).
One operand of a CONCAT operator when the other operand is any graphic data type except DBCLOB	If the other operand is GRAPHIC(<i>n</i>) or VARGRAPHIC(<i>n</i>), where <i>n</i> is less than 64, the data type is VARGRAPHIC(127 -

Location of untyped parameter marker	Data type (or error if not supported)
	<i>n</i>). In all other cases, the data type is VARGRAPHIC(127).
One operand of a CONCAT operator when the other operand is any binary type except BLOB	If the other operand is BINARY(<i>n</i>) or VARBINARY(<i>n</i>) where <i>n</i> is less than 128, the data type is VARBINARY(255- <i>n</i>). In all other cases, the data type is VARBINARY(255)
One operand of a CONCAT operator when the other operand is a LOB string	The data type of the other operand (the LOB string)
The <i>expression</i> following the CASE keyword in a simple CASE expression	Error
Any or all <i>expressions</i> following the WHEN keyword in a simple CASE expression	The result of applying the “Rules for result data types” on page 166 to the expression following CASE and the expressions following WHEN that are not untyped parameter markers
A <i>result-expression</i> in any CASE expression when all the other <i>result-expressions</i> are either NULL or untyped parameter markers.	Error
A <i>result-expression</i> in any CASE expression when at least one other <i>result-expression</i> is neither NULL nor an untyped parameter marker.	The result of applying the “Rules for result data types” on page 166 to all the <i>result-expressions</i> that are not NULL or untyped parameter markers
Alone as a <i>column-expression</i> in a single-row VALUES clause that is not within an INSERT statement or the VALUES clause of an insert operation of a MERGE statement	Error
Alone as a <i>column-expression</i> in a single-row VALUES clause within an INSERT statement	The data type of the column or, if the column is defined as a distinct type, the source data type of the distinct type
Alone as a <i>column-expression</i> in a <i>values-single-row</i> or <i>values-multiple-row</i> clause of <i>source-table</i> for a MERGE statement	The data type of the column of the source-table, or if the data type is a distinct type, the source data type of the distinct type. The column of the source-table must be referenced elsewhere in the MERGE statement such that its data type can be determined from the context in which it is used, and all such references must resolve to the same data type.
Alone as a <i>column-expression</i> in the VALUES clause of an insert operation of a MERGE statement	The data type of the column or, if the column is defined as a distinct type, the source data type of the distinct type
Alone as a <i>column-expression</i> on the right side of <i>assignment-clause</i> for an update operation of a MERGE statement	The data type of the column or, if the column is defined as a distinct type, the source data type of the distinct type
Alone as a <i>column-expression</i> on the right side of a SET clause in an UPDATE statement	The data type of the column or, if the column is defined as a distinct type, the source data type of the distinct type

Location of untyped parameter marker	Data type (or error if not supported)
Alone as <i>offset-row-count</i> in an OFFSET clause	BIGINT
Alone as <i>fetch-row-count</i> in a FETCH clause	BIGINT

Predicates

Location of untyped parameter marker	Data type (or error if not supported)
Both operands of a comparison operator	Error
One operand of a comparison operator when the other operand is not an untyped parameter marker	The data type of the other operand. If the operand has a datetime data type, the result of DESCRIBE INPUT will show the data type as CHAR(255) although Db2 uses the datetime data type in any comparisons.
All the operands of a BETWEEN predicate	Error
Two operands of a BETWEEN predicate (either the first and second, or the first and third)	The data type of the operand that is not a parameter marker
Only one operand of a BETWEEN predicate	The result of applying the “Rules for result data types” on page 166 on the other operands that are not parameter markers
All the operands of an IN predicate, for example, ? IN (?, ?, ?)	Error
The first and second operands of an IN predicate, for example, ? IN (?, A, B)	The result of applying the “Rules for result data types” on page 166 on the operands in the IN list that are not parameter markers
The first operand of an IN predicate and zero or more operands of the IN list except for the first operand of the IN list, for example, ? IN (A, ?, B, ?)	The result of applying the “Rules for result data types” on page 166 on the operands in the IN list that are not parameter markers
The first operand of an IN predicate when the right side is a fullselect of fullselect, for example, ? IN (fullselect)	The data type of the selected column
Any or all operands of the IN list of the IN predicate and the first operand of the IN predicate is not an untyped parameter marker, for example, A IN (?, A, ?)	The data type of the first operand (the operand on the left side of the IN list)
All the operands of a LIKE predicate	The first and second operands (<i>match-expression</i> and <i>pattern-expression</i>) are VARCHAR(4000). The third operand (<i>escape-expression</i>) is VARCHAR(1).
The first operand of a LIKE predicate (the <i>match-expression</i>) when at least one other operand (the <i>pattern-expression</i> or <i>escape-expression</i>) is not an untyped parameter marker.	VARCHAR(4000), VARGRAPHIC(2000), or VARBINARY(4000), depending on the data type of the first operand that is not an untyped parameter marker
The second operand of a LIKE predicate (the <i>pattern-expression</i>) when at least one other	VARCHAR(4000), VARGRAPHIC(2000), or VARBINARY(4000), depending on the data

Location of untyped parameter marker	Data type (or error if not supported)
operand (the <i>match-expression</i> or <i>escape-expression</i>) is not an untyped parameter marker. When the pattern specified in a LIKE predicate is a parameter marker and a fixed-length character host variable is used to replace the parameter marker, specify a value for the host variable that is the correct length. If you do not specify the correct length, the select does not return the intended results.	type of the first operand that is not an untyped parameter marker.
The third operand of a LIKE predicate (the <i>escape-expression</i>) when at least one other operand (the <i>match-expression</i> or <i>pattern-expression</i>) is not an untyped parameter marker	CHAR(1), GRAPHIC(1), or BINARY(1), depending on the data type of the first operand that is not an untyped parameter marker
Operand of a NULL predicate	Error

Functions

Location of untyped parameter marker	Data type (or error if not supported)
All arguments of COALESCE or NULLIF	Error
Any argument of COALESCE or NULLIF when at least one other argument is not an untyped parameter marker	The result of applying the “ Rules for result data types ” on page 166 on the arguments that are not untyped parameter markers, the data type of the other argument
First argument of COLLATION_KEY	VARGRAPHIC(2000)
Second argument of COLLATION_KEY	VARCHAR(255)
First argument of LOWER	VARCHAR(4000)
Second argument of LOWER	VARCHAR(255)
Any argument other than the first argument of MAX	The data type of the corresponding parameter in the function instance
Any argument other than the first argument of MIN	The data type of the corresponding parameter in the function instance
Both arguments of POSSTR or POSITION	VARCHAR(4000) for both arguments
One argument of POSSTR or POSITION when the other argument is a character data type	VARCHAR(4000)
One argument of POSSTR or POSITION when the other argument is a graphic data type	VARGRAPHIC(2000)
One argument of POSSTR or POSITION when the other argument is a BINARY or VARBINARY data type	VARBINARY(4000)
One argument of POSSTR or POSITION when the other argument is a BLOB	BLOB(4000)
First argument of SUBSTR or SUBSTRING	VARCHAR(4000)

Location of untyped parameter marker	Data type (or error if not supported)
Second or third argument of SUBSTR or SUBSTRING	INTEGER
One argument of TIMESTAMP	TIME
First argument of TIMESTAMP_FORMAT	VARCHAR(255)
First argument of TRANSLATE	Error
Second or third argument of TRANSLATE	VARCHAR(4000), VARGRAPHIC(2000), depending on whether the data type of the first argument is character or graphic
Fourth argument of TRANSLATE	VARCHAR(1) or VARGRAPHIC(1), depending on whether the data type of the first argument is character or graphic
Second argument of TRIM_ARRAY	BIGINT
<i>array-index</i> for <i>array-element-specification</i>	BIGINT
First argument of UPPER	VARCHAR(4000)
Second argument of UPPER	VARCHAR(255)
First argument of VARCHAR_FORMAT	TIMESTAMP WITHOUT TIME ZONE
Unary minus	DECFLOAT(34)
Unary plus	Error
The argument of any built-in scalar function (except those that are described in this table)	Error
The argument of a built-in aggregate function	Error
The argument of a user-defined scalar function, user-defined aggregate function, or user-defined table function	The data type of the corresponding parameter in the function instance

Statements

Location of untyped parameter marker	Data type (or error if not supported)
FOR <i>n</i> ROWS clause of an INSERT or MERGE statement	Integer
The value on the right side of a SET clause in an UPDATE statement or the UPDATE clause of the MERGE statement	The data type of the column of the source-table, or if the column is defined as a distinct type, the source data type of the distinct type. The column of the source-table must be referenced elsewhere in the MERGE statement such that its data type can be determined from the context in which it is used, and all such references must resolve to the same data type.
<i>value</i> , <i>value1</i> , or <i>value2</i> in a period specification or period clause	The data type of the columns of the period referenced in the period specification or period clause

Location of untyped parameter marker	Data type (or error if not supported)
<i>value</i> , <i>value1</i> , or <i>value2</i> in a period specification for a table, or period clause for a data change statement if the target of the statement is a table	The data type of the columns of the period referenced in the period specification or period clause
<i>value</i> , <i>value1</i> , or <i>value2</i> in a period specification for a view	Error
<i>value1</i> or <i>value2</i> in a period clause in a data change statement if the target of the statement is a view	Error

Considerations for FETCH statements used with a sensitive static cursor:

Whether changes made outside the cursor are visible to the cursor depends on the type of FETCH that is used with a SENSITIVE STATIC cursor:

- A SENSITIVE FETCH is sensitive to all updates and deletes that are made by this cursor (including changes made by triggers) and committed updates and deletes by all other application processes because every fetched row is retrieved from the underlying base table and not a temporary table. This is the default type of FETCH statement for a SENSITIVE cursor.

Changes that are made to the underlying data using this cursor result in an automatic refresh of the row. The changes that are made using this type of cursor can result in holes in the result table of the cursor. In addition, re-fetching rows (fetching rows that have already been retrieved) can result in holes in the result table. If a sensitive FETCH is issued to re-fetch a row and the row no longer qualifies for the search condition of the query, it results in a "delete hole" or an "update hole". In this case, no data is returned, and the cursor is left positioned on the hole.

- An INSENSITIVE FETCH is not sensitive to updates and deletes that are made outside this cursor; however, it is sensitive to all updates and deletes that are made by this cursor. Changes that made with triggers are not visible with an INSENSITIVE FETCH until the content of the rows are updated in the result table with a SENSITIVE FETCH statement. If an application does not want to be sensitive to changes that are made outside this cursor (that is, the application does not want to see changes made either with another cursor or by another application process), INSENSITIVE can be explicitly specified as part of the FETCH statement for a SENSITIVE STATIC cursor. This type of FETCH is useful for refreshing data in user data buffers. For more information, see [INSENSITIVE](#).

Error checking:

When a PREPARE statement is executed, the statement string is parsed and checked for errors. If the statement string is invalid, a prepared statement is not created and the error condition that prevents its creation is reported in the SQLCA.

In local and remote processing, the DEFER(PREPARE) and REOPT(ALWAYS)/REOPT(ONCE) bind options can cause some SQL statements to receive "delayed" errors. For example, DESCRIBE, EXECUTE, and OPEN might receive an SQLCODE that normally occurs during PREPARE processing.

Reference and execution rules:

Prepared statements can be referred to in the following kinds of statements, with the following restrictions:

Type of statement	Restriction for prepared statement
DESCRIBE	no restriction
DECLARE CURSOR	Statement must be SELECT when the cursor is opened
EXECUTE	Statement must not be SELECT

A prepared statement can be executed many times. Indeed, if a prepared statement is not executed more than once and does not contain parameter markers, it is more efficient to use the EXECUTE IMMEDIATE statement rather than the PREPARE and EXECUTE statements.

Prepared statement persistence:

All prepared statements created by a unit of work are destroyed when the unit of work is terminated, with the following exceptions:

- A SELECT statement whose cursor is declared with the option WITH HOLD persists over the execution of a commit operation if the cursor is open when the commit operation is executed.
- SELECT, INSERT, UPDATE, MERGE, and DELETE statements that are bound with KEEP DYNAMIC(YES) are kept past the point of commit or rollback if your system is enabled for dynamic statement caching, and none of the following are true:
 - SQL RELEASE has been issued for the site
 - Bind option DISCONNECT(AUTOMATIC) was used
 - Bind option DISCONNECT(CONDITIONAL) was used and there are no hold cursors for the site
- INSERT, UPDATE, MERGE, and DELETE statements that are bound with or use the RELEASE(DEALLOCATE) option and that reference a declared global temporary table are kept past commit operations unless one of the following statements is true:
 - The declared global temporary table is defined with the ON COMMIT DROP TABLE option.
 - The statement also references a Db2 base object (for example, a table or view), and one of the following statements is true:
 - The base object reference is for a Db2 catalog table.
 - At the commit point, Db2 determines that another Db2 thread is waiting for an X-lock on the base object's database descriptor (DBD).
 - The statement references an XML function or operation, and at the commit point Db2 determines that the base object DBD S-lock for the XML operation must be released.
 - At the commit point, Db2 determines that a base object DBD S-lock that is used by the statement must be released and cannot be maintained across the commit point.
 - Db2 determines that another Db2 thread is waiting for an X-lock on the Db2 package that contains the statement.

Scope of a statement name:

The scope of a *statement-name* is the same as the scope of a *cursor-name*. See [“DECLARE CURSOR statement” on page 1819](#) for more information about the scope of a *cursor-name*.

Preparation with PREPARE INTO and REOPT bind option:

If bind option REOPT(ALWAYS) or REOPT(ONCE) is in effect, PREPARE INTO is equivalent to a PREPARE and a DESCRIBE being performed. If a statement has input variables, the DESCRIBE causes the statement to be prepared with default values, and the statement must be prepared again when it is opened or executed. When REOPT(ONCE) is in effect, the statement is always prepared twice even if there are no input variables. Therefore, to avoid having a statement prepared twice, avoid using PREPARE INTO when REOPT(ALWAYS) or REOPT(ONCE) is in effect.

Relationship of cursor attributes on PREPARE statements and SELECT or DECLARE CURSOR statements:

Cursor attributes that are specified as part of the *select-statement* are used instead of any corresponding options that specified with the ATTRIBUTES clause on PREPARE. Attributes that are specified as part of the ATTRIBUTES clause of PREPARE take precedence over any corresponding option that is specified with the DECLARE CURSOR statement. The order for using cursor attributes is as follows:

- SELECT (highest priority)
- PREPARE statement ATTRIBUTES clause
- DECLARE CURSOR (lowest priority)

For example, assume that host variable MYQ has been set to the following SELECT statement:

```
SELECT WORKDEPT, EMPNO, SALARY, BONUS, COMM
FROM EMP
WHERE WORKDEPT IN ('D11', 'D21')
FOR UPDATE OF SALARY, BONUS, COMM
```

If the following PREPARE statement were issued, then the FOR UPDATE clause specified as part of the SELECT statement would be used instead of the FOR READ ONLY clause specified with the ATTRIBUTES clause as part of the PREPARE statement. Thus, the cursor would be updatable.

```
attrstring = 'FOR READ ONLY';
EXEC SQL PREPARE stmt1 ATTRIBUTES :attrstring FROM :MYQ;
```

Effect of the CURRENT EXPLAIN MODE special register:

If the CURRENT EXPLAIN MODE special register is set to EXPLAIN, the statement is prepared for explain only and is not executable, unless the statement is a SET statement. Attempting to execute the prepared statement will return an error. See the [“CURRENT EXPLAIN MODE special register”](#) on page 194 special register for more information.

Precedence of attributes for SELECT and UPDATE WHERE CURRENT OF for positioned updates:

If an UPDATE WHERE CURRENT OF statement and the associated SELECT statement are both prepared and both statements have the same PREPARE attributes, the values of the PREPARE attributes for the UPDATE WHERE CURRENT OF statement override the values of the PREPARE attributes for the SELECT statement.

Effect of extended indicator PREPARE attributes on dynamically executed positioned updates:

If an UPDATE statement with the WHERE CURRENT OF clause and the associated SELECT statement are both prepared, if extended indicator variables are used depends on the WITH EXTENDED INDICATORS or WITHOUT EXTENDED INDICATORS attributes in each of the PREPARE statements.

Interaction between EXTENDED INDICATOR attributes of PREPARE statements for SELECT and UPDATE statements

Extended indicator attribute of PREPARE for SELECT statement	Extended indicator attribute of PREPARE for UPDATE statement with WHERE CURRENT OF clause	Result
WITH EXTENDED INDICATORS	WITH EXTENDED INDICATORS	The PREPARE attributes of the UPDATE statement override the PREPARE attributes of the SELECT statement. Non-updatable columns can be in the select-list.
WITH EXTENDED INDICATORS	WITHOUT EXTENDED INDICATORS	The UPDATE statement is executed without extended indicator parameters.
WITH EXTENDED INDICATORS	Default (without attribute specified)	The PREPARE attributes of the SELECT statement override the default PREPARE attributes for the UPDATE statement. Non-updatable columns can be in the select-list.
WITHOUT EXTENDED INDICATORS	WITH EXTENDED INDICATORS	The PREPARE attributes of the UPDATE statement override the PREPARE attributes of the SELECT statement. Non-updatable columns are not in the implicit or explicit select-list.
WITHOUT EXTENDED INDICATORS	WITHOUT EXTENDED INDICATORS	The UPDATE statement is executed without extended indicator parameters.
WITHOUT EXTENDED INDICATORS	Default (without attribute specified)	The PREPARE attributes of the SELECT statement override the default PREPARE attributes for the

Extended indicator attribute of PREPARE for SELECT statement	Extended indicator attribute of PREPARE for UPDATE statement with WHERE CURRENT OF clause	Result
		UPDATE statement. The UPDATE statement is executed without extended indicator parameters.
Default (without attribute specified)	WITH EXTENDED INDICATORS	The PREPARE attributes of the UPDATE statement override the PREPARE attributes of the SELECT statement. Non-updatable columns are not in the implicit or explicit select-list.
Default (without attribute specified)	WITHOUT EXTENDED INDICATORS	The PREPARE attributes of the UPDATE statement override the PREPARE attributes of the SELECT statement. The UPDATE statement is executed without extended indicator parameters.
Default (without attribute specified)	Default (without attribute specified)	The UPDATE statement is executed without extended indicator parameters.

Interactions between the SKIPUNCI subsystem parameter and the PREPARE statement:

When the PREPARE statement is specified with either the CURRENTLY COMMITTED or WAIT FOR OUTCOME clauses and the subsystem parameter SKIPUNCI is in effect, the following table describes whether uncommitted inserts are skipped, or if the transaction will wait until a commit or rollback before completing:

Interaction between SKIPUNCI subsystem parameter and PREPARE statement

Value of SKIPUNCI subsystem parameter	PREPARE statement attributeworking	Skip uncommitted inserts, or wait for commit or rollback
YES	CURRENTLY COMMITTED	Skip
YES	WAIT FOR OUTCOME	Wait
YES	Not specified	Skip
NO	CURRENTLY COMMITTED	Skip
NO	WAIT FOR OUTCOME	Wait
NO	Not specified	Wait

Extended indicator variables and deferred error checks:

When extended indicator variables are enabled, the indicator value of unassigned causes the associated target column to be omitted from the statement. Because of that, validation that is normally done in statement preparation (to recognize an INSERT into, or UPDATE of, a non-updatable column) is deferred until statement execution. If statement validation fails, an error is returned when the statement is run, not when the statement is prepared.

Reuse of prepared statements in the dynamic statement cache with CONCENTRATE STATEMENTS WITH LITERALS

To be eligible for reuse of constants, the constants in both the new statement and the cached statement must have the same:

1. immediate usage context
2. data type
3. data type length and size

If Db2 determines that both instances of the constant meet the criteria for reuse, a cached statement that is prepared using the `CONCENTRATE STATEMENTS WITH LITERALS` option can be shared by the same SQL statement with different constants. Even though the new dynamic SQL statement will share the cached statement, the new statement will use its own literal constants when the statement is run, not the constants of the cached statement.

There are some exceptions. For example, the built-in function `SUBSTR`, for which, because of the immediate usage context, constant reuse in the cached statement that uses a different constant value can not be done without the risk of returning incorrect output or results. In such cases, only an SQL statement instance with the exact same constant value as the cached version of the statement is eligible for reuse. Db2 determines when and where this immediate usage context restriction applies.

When the `CONCENTRATE STATEMENTS WITH LITERALS` option is specified, Db2 considers the values of the literal constants for access path selection only for statements that are bound with the `REOPT(ONCE)` or `REOPT(AUTO)` bind options.

The `DECFLOAT` defined constants `NAN`, `SNAN`, and `INFINITY` can qualify for literal constant reuse.

The following examples show how `PREPARE` is used with `CONCENTRATE STATEMENTS WITH LITERALS`. `X`, `Y`, and `Z` are columns of defined as `DECIMAL` data type:

```
DECLARE C1 CURSOR
  FOR DYNSQL_WITH_LITERAL;

DYNSQL_SELECT = 'SELECT X, Y, Z
                FROM TABLE1
                WHERE X < 9';

attrstring = 'CONCENTRATE STATEMENTS WITH LITERALS';

EXEC SQL PREPARE DYNSQL_WITH_LITERAL
  ATTRIBUTES :attrstring
  FROM :DYNSQL_SELECT;

EXEC SQL OPEN C1;
```

```
DYNSQL_INSERT = 'INSERT INTO
                TABLE1 (X, Y, Z)
                VALUES (8,109,29)';

attrstring = 'CONCENTRATE STATEMENTS WITH LITERALS';

EXEC SQL PREPARE DYNSQL_INSERT_WITH_LITERAL
  ATTRIBUTES :attrstring
  FROM :DYNSQL_INSERT;

EXEC SQL EXECUTE DYNSQL_INSERT_WITH_LITERAL;
```

Examples for PREPARE

Example 1

In this PL/I example, an `INSERT` statement with parameter markers is prepared and executed. Before execution, values for the parameter markers are read into the host variables `S1`, `S2`, `S3`, `S4`, and `S5`.

```
EXEC SQL PREPARE DEPT_INSERT FROM
  'INSERT INTO DSN8C10.DEPT VALUES(?,?,?,?)';
-- Check for successful execution and read values into host variables
EXEC SQL EXECUTE DEPT_INSERT USING :S1, :S2, :S3, :S4, :S5;
```

Example 2

Prepare a dynamic `SELECT` statement specifying the attributes of the cursor with a host variable on the `PREPARE` statement. Assume that the text of the `SELECT` statement is in a variable named `stmttxt`, and that the attributes of the cursor are in a variable named `attrvar`.

```
EXEC SQL DECLARE mycursor CURSOR FOR mystmt;
EXEC SQL PREPARE mystmt ATTRIBUTES :attrvar
  FROM :stmttxt;
EXEC SQL DESCRIBE mystmt INTO :mysqlda;
```

```
EXEC SQL OPEN mycursor;  
EXEC SQL FETCH FROM mycursor USING DESCRIPTOR :mysqllda;
```

REFRESH TABLE statement

The REFRESH TABLE statement refreshes the data in a materialized query table. The statement deletes all rows in the materialized query table, executes the fullselect in the table definition to recalculate the data from the tables specified in the fullselect, inserts the calculated result into the materialized query table, and updates the catalog for the refresh timestamp and cardinality of the table. The table can exist at the current server or at any Db2 subsystem with which the current server can establish a connection.

Invocation for REFRESH TABLE

This statement can be embedded in an application program or issued interactively. It is an executable statement that can be dynamically prepared only if DYNAMICRULES RUN behavior is in effect. For more information, see [“Authorization IDs and dynamic SQL”](#) on page 94.

Authorization for REFRESH TABLE

The privilege set for REFRESH TABLE must include at least one of the following authorities:

- Ownership of the materialized query table
- DBADM or DBCTRL authority on the database that contains the materialized query table
- SYSADM or SYSCTRL authority
- DATAACCESS authority

If the database is implicitly created, the database privileges must be on the implicit database or on DSNDB04.

Privilege set: If the statement is embedded in an application program, the privilege set is the privileges that are held by the owner of the plan or package. If the statements dynamically prepared, the privilege set is determined by the DYNAMICRULES behavior in effect (run, bind, define, or invoke). For more information on these behaviors, including a list of the DYNAMICRULES bind option values, see [“Authorization IDs and dynamic SQL”](#) on page 94.

Syntax for REFRESH TABLE

```
►► REFRESH TABLE — table-name —————►  
                                  └── QUERYNO — integer ─┘
```

Description for REFRESH TABLE

table-name

Identifies the table to be refreshed. The name must identify a materialized query table. REFRESH TABLE evaluates the fullselect in the *materialized-query-definition* clause to refresh the table. The isolation level for the fullselect is the isolation level of the materialized query table recorded when CREATE TABLE or ALTER TABLE was issued.

QUERYNO *integer*

Specifies the number to be used for this SQL statement in EXPLAIN output and trace records. The number is used for the QUERYNO column of the plan table for the rows that contain information about this SQL statement. This number is also used in the QUERYNO column of the SYSIBM.SYSSTMT and SYSIBM.SYSPACKSTMT catalog tables.

If the clause is omitted, the number associated with the SQL statement is the statement number assigned during precompilation. Thus, if the application program is changed and then precompiled, that statement number might change.

Notes for REFRESH TABLE

Automatic query rewrite using materialized query tables is not attempted for the fullselect in the materialized query table definition during the processing of REFRESH TABLE statement.

After successful execution of a REFRESH TABLE statement, the SQLCA field SQLERRD(3) will contain the number of rows inserted into the materialized query table.

The EXPLAIN output for REFRESH TABLE *table-name* is the same as the EXPLAIN output for INSERT INTO *table-name fullselect* where *fullselect* is from the materialized query table definition.

If the materialized query table has a security label column, the REFRESH TABLE statement does not do any checking for multilevel security with row-level granularity when it deletes and repopulates the data in the table by executing the fullselect. Instead, Db2 performs the checking for multilevel security with row-level granularity when the materialized query table is exploited in automatic query rewrite or is used directly.

The REFRESH TABLE statement can be used to remove a table space from the logical page list and reset recover-pending status. This can only be done by using REFRESH TABLE to repopulate a materialized query table where the materialized query table is the only table in the table space.

Example for REFRESH TABLE

Issue a statement to refresh the content of a materialized query table that is named SALESCOUNT. The statement recalculates the data from the fullselect that was used to define SALESCOUNT and refreshes the content of SALESCOUNT with the recalculated results.

```
REFRESH TABLE SALESCOUNT;
```

RELEASE statement (connection)

The RELEASE (connection) statement places one or more connections in the release pending state.

Invocation for RELEASE (connection)

This statement can only be embedded in an application program. It is an executable statement that cannot be dynamically prepared. It must not be specified in Java.

Authorization for RELEASE (connection)

None required.

Syntax for RELEASE (connection)



Description for RELEASE (connection)

location-name or *host-variable*

Identifies an SQL connection by the specified location name or the location name contained in the host variable. If a host variable is specified:

- It must be a character string variable with a length attribute that is not greater than 16. (A C NUL-terminated character string can be up to 17 bytes.)
- It must not be followed by an indicator variable.
- The location name must be left-justified within the host variable and must conform to the rules for forming an ordinary location identifier.
- If the length of the location name is less than the length of the host variable, it must be padded on the right with blanks.

The specified location name or the location name contained in the host variable must identify an existing SQL connection of the application process.

CURRENT

Identifies the current SQL connection of the application process. The application process must be in the connected state.

ALL or ALL SQL

Identifies all existing connections (including local, and SQL) of the application process. An error or warning does not occur if no connections exist when the statement is executed.

If the RELEASE (connection) statement is successful, each identified connection is placed in the release-pending state and, therefore, will be ended during the next commit operation. If the RELEASE (connection) statement is unsuccessful, the connection state of the application process and the states of its connections are unchanged.

Notes for RELEASE (connection)

RELEASE and CONNECT (Type 1): Using CONNECT (Type 1) semantics does not prevent using RELEASE (connection).

Scope of RELEASE: RELEASE (connection) does not close cursors, does not release any resources, and does not prevent further use of the connection.

Resource considerations for remote connections: Resources are required to create and maintain remote connections. Thus, a remote connection that is not going to be reused should be in the release pending status and one that is going to be reused should not be in the release pending status. Remote connections can also be ended during a commit operation as a result of the DISCONNECT(AUTOMATIC) or DISCONNECT(CONDITIONAL) bind option.

If the current SQL connection is in the release pending status when a commit operation is performed, the connection is ended and the application process is in the unconnected state. In this case, the next executed SQL statement should be CONNECT or SET CONNECTION.

Connection states: ROLLBACK does not reset the state of a connection from release pending to held.

If the current SQL connection is in the release pending state when a commit operation is performed, the connection is ended and the application process is in the unconnected state. In this case, the next executed SQL statement must be CONNECT or SET CONNECTION.

For further information, see [“Application process connection states” on page 71.](#)

Location names CURRENT and ALL: A database server named CURRENT or ALL can only be identified by a host variable or a delimited identifier. A connection in the release pending state is ended during a commit operation even though it has an open cursor defined with WITH HOLD.

Encoding scheme of a host variable: If the RELEASE statement contains host variables, the contents of the host variables are assumed to be in the encoding scheme that was specified in the ENCODING parameter when the package or plan that contains the statement was bound.

Examples for RELEASE (connection)

Example 1: The SQL connection to TOROLAB1 is not needed in the next unit of work. The following statement causes it to be ended during the next commit operation:

```
EXEC SQL RELEASE TOROLAB1;
```

Example 2: The current SQL connection is not needed in the next unit of work. The following statement causes it to be ended during the next commit operation:

```
EXEC SQL RELEASE CURRENT;
```

RELEASE SAVEPOINT statement

The RELEASE SAVEPOINT statement releases the identified savepoint and any subsequently established savepoints within a unit of recovery.

Invocation for RELEASE SAVEPOINT

This statement can be imbedded in an application program or issued interactively. It is an executable statement that can be dynamically prepared.

Authorization for RELEASE SAVEPOINT

None required.

Syntax for RELEASE SAVEPOINT

```
►► RELEASE  TO SAVEPOINT — savepoint-name ◄◄
```

Description for RELEASE SAVEPOINT

savepoint-name

Identifies the savepoint to release. If the named savepoint does not exist, an error occurs. The name must identify a savepoint that exists at the current server. After a savepoint is released, it is no longer maintained and rollback to the savepoint is no longer possible.

Notes for RELEASE SAVEPOINT

Savepoint names: The name of the savepoint that was released can be reused in another SAVEPOINT statement, regardless of whether the UNIQUE keyword was specified on an earlier SAVEPOINT statement that specified this same savepoint name.

Example for RELEASE SAVEPOINT

Assume that a main routine sets savepoint A and then invokes a subroutine that sets savepoints B and C. When control returns to the main routine, release savepoint A and any subsequently set savepoints. Savepoints B and C, which were set by the subroutine, are released in addition to A.

```
⋮  
RELEASE SAVEPOINT A;
```

RENAME statement

The RENAME statement renames an existing table or index. An accelerator-only table cannot be renamed.

Invocation for RENAME

This statement can be embedded in an application program or issued interactively. It is an executable statement that can be dynamically prepared only if DYNAMICRULES RUN behavior is in effect. For more information, see [“Authorization IDs and dynamic SQL”](#) on page 94.

Authorization for RENAME

To rename a table, the privilege set that is defined below must include at least one of the following privileges:

- Ownership of the table
- DBADM, DBCTRL, or DBMAINT authority for the database that contains the table
- SYSADM or SYSCTRL authority
- System DBADM

If the database is implicitly created, the database privileges must be on the implicit database or on DSNDB04.

To rename an index, the privilege set that is defined below must include at least one of the following privileges:

- Ownership of the table for which the index is defined
- Ownership of the index that is being renamed
- DBADM, DBCTRL, or DBMAINT authority for the database that contains the index
- SYSADM or SYSCTRL authority
- System DBADM

If the database is implicitly created, the database privileges must be on the implicit database or on DSNDB04.

Privilege set: If the statement is embedded in an application program, the privilege set is the privileges that are held by the owner of the plan or package. If the statement is dynamically prepared, the privilege set is the union of the privilege sets that are held by each authorization ID of the process.

Syntax for RENAME

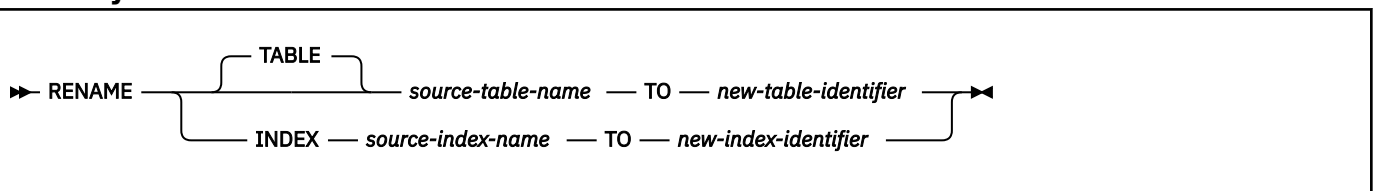

Description for RENAME

source-table-name

Identifies the existing table that is to be renamed. The name, including the implicit or explicit qualifier, must identify a table that exists at the current server. The name must not identify any of the following types of tables:

- A declared temporary table
- A catalog table
- A directory table

- An active resource limit specification table
- A materialized query table
- A clone table
- A system-period temporal table
- A history table for a system-period temporal table
- A table with a trigger defined on it
- A table that is referenced in the definition of a row permission
- A table that is referenced in the definition of a column mask
- A view
- A synonym
- An archive-enabled table
- An archive table
- An SQL table function

If you specify a three-part name or alias for the source table, the source table must exist at the current server. If any view definitions or materialized query table definitions currently reference the source table, an error occurs.

new-table-identifier

Specifies the new name for the table without a qualifier. The qualifier of the *source-table-name* is used to qualify the new name for the table. The qualified name must not identify a table, view, alias, or synonym that exists at the current server, or a table that exists in the SYSIBM.SYSPENDINGOBJECTS catalog table.

For more information, see [Guidelines for table names \(Db2 Administration Guide\)](#).

source-index-name

Identifies the existing index that is to be renamed. The name, including an implicit or explicit qualifier, must identify an index that exists at the current server. The name must not identify a system defined catalog index, a directory index, an index on a declared temporary table, or an index on an active resource limit specification table.

new-index-identifier

Specifies that new name for the index without a qualifier. The qualifier of the *source-index-name* is used to qualify the new name for the index. The qualified name must not identify an index that exists at the current server or an index that exists in the SYSIBM.SYSPENDINGOBJECTS catalog table.

For more information, see [Index names and guidelines \(Db2 Administration Guide\)](#).

Notes for RENAME

Effects of the statement

The specified table or index is renamed to the new name. For a renamed table, all privileges and indexes on the table are preserved. For a renamed index, all privileges are preserved.

Invalidation of packages:

This statement might invalidate all packages that depend on target objects, and sometimes other related objects through cascading effects, depending on the clauses and keywords specified and other factors. For more information, see [Changes that invalidate packages \(Db2 Application programming and SQL\)](#).

Restriction when there are pending changes to the definition

A RENAME INDEX statement is not allowed if there are pending changes to the definition of the index.

A RENAME TABLE statement is not allowed if there are pending changes to the definition of the table .

Alias considerations

If an alias name is specified for *table-name*, the table must exist at the current server, and the table that is identified by the alias is renamed. The name of the alias is not changed and continues to refer to the old table name after the rename.

Changing the name of an alias with the RENAME statement is not supported. To change the name to which an alias refers, you must drop the alias and then re-create it.

PLAN_TABLE considerations

The RENAME INDEX statement does not update the contents of a plan table. Rows that exist in a plan table that are generated from a EXPLAIN statement can contain the name of an index in the access path selections. When an index is renamed, any entries in existing plan tables that refer to the old index name are not updated.

Transfer of authorization, referential integrity constraints, and indexes

All authorizations associated with the source table name are *transferred* to the new (target) table name. The authorization catalog tables are updated appropriately.

Referential integrity constraints involving the source table are updated to refer to the new table. The catalog tables are updated appropriately.

Indexes that are defined for the source table are *transferred* to the new table. The index catalog tables are updated appropriately.

Object identifier

Renamed tables and indexes keep the same object identifier as the original table or index.

Renaming registration tables

If an application registration table (ART) or object registration table (ORT) or an index of an ART or ORT is specified as the source table for RENAME, when RENAME completes, it is as if that table had been dropped. There is no ART or ORT once the ART or ORT table has been renamed.

Renaming a table with dependent views or SQL table functions

The RENAME TABLE statement returns an error if the target table is referenced in a view definition or an SQL table function, unless the RENAMETABLE subsystem parameter is set to ALLOW_DEP_VIEW_SQLTUDF.

Catalog table updates

Entries in the following catalog tables are updated to reflect the new table:

- SYSAUXRELS
- SYSCHECKS
- SYSCHECKS2
- SYSCHECKDEP
- SYSCOLAUTH
- SYSCOLDIST
- SYSCOLDIST_HIST
- SYSCOLDISTSTATS
- SYSCOLSTATS
- SYSCOLUMNS
- SYSCOLUMNS_HIST
- SYSCONSTDEP
- SYSFIELDS
- SYSFOREIGNKEYS
- SYSINDEXES
- SYSINDEXES_HIST
- SYSKEYCOLUSE
- SYSPLANDEP

- SYSPACKDEP
- SYSRELS
- SYSSEQUENCESDEP
- SYSSYNONYMS
- SYSTABAUTH
- SYSTABCONST
- SYSTABLES
- SYSTABLES_HIST
- SYSTABSTATS
- SYSTABSTATS_HIST

Entries in SYSSTMT and SYSPACKSTMT are not updated.

Entries in the following catalog tables are updated to reflect the new index:

- SYSDEPENDENCIES
- SYSINDEXES
- SYSINDEXES_HIST
- SYSINDEXESPART
- SYSINDEXESPART_HIST
- SYSINDEXSPACESTATS
- SYSINDEXSTATS
- SYSINDEXSTATS_HIST
- SYSKEYS
- SYSKEYTARGETS
- SYSKEYTARGETS_HIST
- SYSKEYTARGETSTATS
- SYSKEYTGTDIST
- SYSKEYTGTDIST_HIST
- SYSKEYTGTDISTSTATS
- SYSOBJROLEDEP
- SYSPACKDEP
- SYSPLANDEP
- SYSRELS
- SYSTABCONST
- SYSTABLEPART

Examples for RENAME

Example 1: Change the name of the EMP table to EMPLOYEE:

```
RENAME TABLE EMP TO EMPLOYEE;
```

Example 2: Change the name of the EMP_USA_HIS2002:

```
RENAME TABLE EMP_USA_HIS2002 TO EMPLOYEE_UNITEDSTATES_HISTORY2002;
```

Example 3: Change the name of the EMPINDX1 to EMPLOYEE_INDEX:

```
RENAME INDEX COMPANY.EMPINDX1 TO EMPLOYEE_INDEX;
```

REVOKE statement

The REVOKE statement revokes privileges from authorization IDs.

A separate form of the statement exists for each of the following privilege classes:

- [Collection](#)
- [Database](#)
- [Function or stored procedure](#)
- [Package](#)
- [Plan](#)
- [Schema](#)
- [Sequence](#)
- [System](#)
- [Table or view](#)
- [Type or JAR file](#)
- [Variable](#)
- [Use](#)

The applicable objects are always at the current server.

Invocation for REVOKE

This statement can be embedded in an application program or issued interactively. It is an executable statement that can be dynamically prepared only if DYNAMICRULES RUN behavior is in effect. For more information, see [“Authorization IDs and dynamic SQL”](#) on page 94.

If the authorization mechanism was not activated when the Db2 subsystem was installed, an error condition occurs.

Authorization for REVOKE

If the BY clause is not specified, the authorization ID of the statement must have granted at least one of the specified privileges to every *authorization-name* specified in the FROM clause (including PUBLIC, if specified). If the BY clause is specified, the authorization ID of the statement must have SECADM or ACCESSCTRL authority.

Note: If installation parameter SEPARATE SECURITY is NO, SYSADM authority has implicit SECADM authority and SYSCTRL authority has implicit ACCESSCTRL authority.

If the BY clause is specified and the privilege set includes ACCESSCTRL, all privileges and authorities can be revoked except for the following:

- System DBADM
- ACCESSCTRL
- DATAACCESS
- CREATE_SECURE_OBJECT privilege

To revoke the CREATE_SECURE_OBJECT privilege, with or without the BY clause, the privilege set must include SECADM authority.

If the statement is embedded in an application program, the privilege set is the privileges that are held by the owner of the plan or package. The owner can be a role. If the statement is dynamically prepared,

the privilege set is the privileges that are held by the SQL authorization ID of the process. However, if the process is running in a trusted context that is defined with the `ROLE AS OBJECT OWNER AND QUALIFIER CLAUSE`, the privilege set is the privileges that are held by the role that is in effect.

Syntax for REVOKE

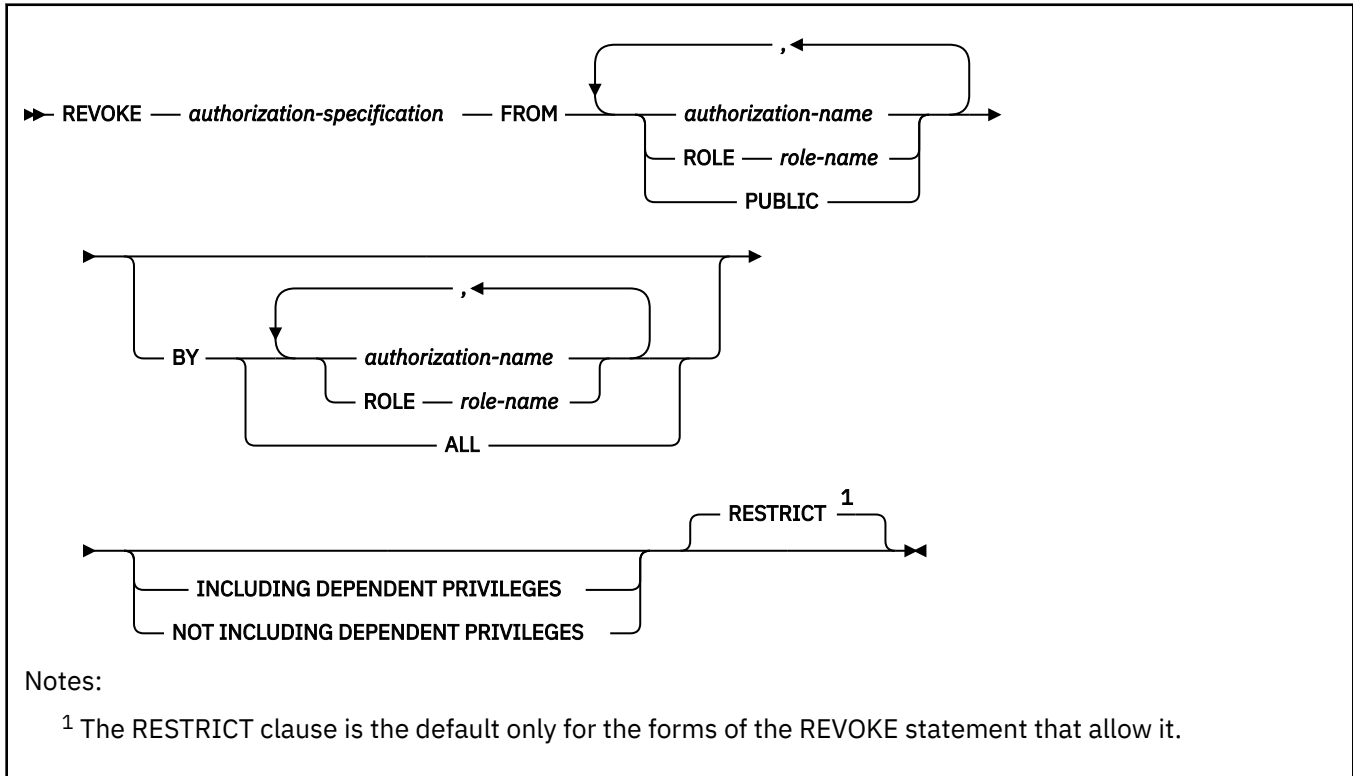

Description for REVOKE

authorization-specification

Specifies one or more privileges for the class of privilege. The same privilege must not be specified more than once.

FROM

Specifies from what authorization IDs the privileges are revoked.

authorization-name,...

Lists one or more authorization IDs. Do not use the same authorization ID more than one time. If the *authorization-name* is specified in lowercase, it must be delimited using double quotes.

The value of CURRENT RULES determines if you can use the ID of the REVOKE statement itself (to revoke privileges from yourself). When CURRENT RULES is:

Db2

You cannot use the ID of the REVOKE statement.

STD

You can use the ID of the REVOKE statement.

ROLE *role-name*

Lists one or more roles. Do not specify the same role more than one time.

PUBLIC

Revokes a grant of privileges to PUBLIC.

BY

Lists grantors who have granted privileges and revokes each named privilege that was explicitly granted to some named user by one of the named grantors. Only an authorization ID or role with

SYSADM or SYSCTRL authority can use BY, even if the authorization ID or role names only itself in the BY clause.

authorization-name,...

Lists one or more authorization IDs of users who were the grantors of the privileges named. Do not use the same authorization ID more than once. Each grantor that is listed must have explicitly granted some named privilege to all of the named users or roles.

ROLE *role-name*

Lists one or more roles that were the grantors of the privileges named. Do not specify the same role more than one time. Each grantor that is listed must have explicitly granted some named privilege to all of the named users or roles.

ALL

Revokes each named privilege from all named users who were explicitly granted the privilege, regardless of who granted it.

INCLUDING DEPENDENT PRIVILEGES or NOT INCLUDING DEPENDENT PRIVILEGES

Specifies whether revoking a privilege or an authority from an authorization ID or a role also results in revoking the grants that were made by that user. The default value is based on the authority that is being revoked and the REVOKE_DEP_PRIVILEGES system parameter:

- When ACCESSCTRL, DATAACCESS, or system DBADM authority is revoked, NOT INCLUDING DEPENDENT PRIVILEGES is assumed and the clause must be specified on the REVOKE statement.
- When the REVOKE_DEP_PRIVILEGES system parameter is set to NO, NOT INCLUDING DEPENDENT PRIVILEGES is assumed and an error is returned if the statement includes INCLUDING DEPENDENT PRIVILEGES.
- Otherwise, INCLUDING DEPENDENT PRIVILEGES is assumed and the clause must be specified on the REVOKE statement.

INCLUDING DEPENDENT PRIVILEGES

Specifies that revoking a privilege or an authority from an authorization ID or a role also results in revoking dependent privileges. This means that any grants that were made by the user will continue to be revoked, until all grants in the chain have been revoked.

INCLUDING DEPENDENT PRIVILEGES cannot be specified if the system parameter REVOKE_DEP_PRIVILEGES is set to NO, which enforces the behavior to not include the dependent privileges.

NOT INCLUDING DEPENDENT PRIVILEGES

Specifies that revoking a privilege or an authority from an authorization ID or a role does not cause the grants that were made by the user to be revoked. However, for the revoked privileges, all implications of the privilege being revoked are applied. For example, if the revoked privileges were required to bind a package successfully, that package would continue to be invalidated as a result of the package owner losing these privileges. An object might be dropped if a privilege is revoked that was used to create the object.

NOT INCLUDING DEPENDENT PRIVILEGES must be specified when ACCESSCTRL, DATAACCESS, or system DBADM authority is revoked.

NOT INCLUDING DEPENDENT PRIVILEGES cannot be specified if the system parameter REVOKE_DEP_PRIVILEGES is set to YES, which enforces the behavior to include dependent privileges in the revoke.

RESTRICT

Prevents the named privilege from being revoked when certain conditions apply. RESTRICT is the default only for the forms of the REVOKE statement that allow it. These forms are revoking the USAGE privilege on distinct types, the EXECUTE privilege on user-defined functions and stored procedures, the USAGE privilege on sequences, and READ or WRITE privileges for variables.

Notes for REVOKE

Revoked privileges

The privileges revoked from an authorization ID or a role are those that are identified in the statement and which were granted to the user by the grantor. Other privileges can be revoked as the result of revoking dependent privileges. For more on Db2 privileges, see [Privileges and authorities \(Managing Security\)](#).

Revoke dependent privileges

Revoking a privilege from a user can also cause that privilege to be revoked from other users. This was previously known as *cascade revoke*. When revoking a privilege from an authorization ID or a role, Db2 looks for and revokes any grants of the privilege where the grantor is the same as the authorization ID or role of the original revoke. The following rules must be true for privilege P' to be revoked from U3 when U1 revokes privilege P from U2:

- P and P' are the same privilege.
- U2 granted privilege P' to U3.
- No one granted privilege P to U2 prior to the grant by U1.
- U2 does not have installation SYSADM authority.

The rules also apply to the implicit grants that are made as a result of a CREATE VIEW statement.

Revoking dependent privileges does not occur under any of the following conditions:

- The privilege was granted by a current installation SYSADM user.
- The privilege is the USAGE privilege on a distinct type and the revokee owns any of these items:
 - A user-defined function or stored procedure that uses the distinct type
 - A table that has a column that uses the distinct type
 - A sequence whose data type is the distinct type
- The privilege is the USAGE privilege on a sequence and the revokee owns any of these items:
 - A trigger that has a NEXT VALUE or PREVIOUS VALUE expression that specifies the sequence
 - An inline SQL function that has a NEXT VALUE or PREVIOUS VALUE expression in the function body that specifies the sequence
- The privilege is the EXECUTE privilege on a user-defined function and the revokee owns any of these items:
 - A user-defined function that is sourced on the function
 - A view that uses the function
 - A trigger package that uses the function
 - A table that uses the function in a check constraint or a user-defined default type
- The privilege is the EXECUTE privilege on a stored procedure and the revokee owns any of these items:
 - A trigger package that refers to the stored procedure in a CALL statement.
- If the ACCESSCTRL administrative authority is revoked from a user, grants that are made by this ACCESSCTRL user are not revoked.

If this user revoked grants made by it, those revokes will continue to revoke the dependent privileges, unless the behavior to not include the dependent privileges was specified either by using the system parameter REVOKE_DEP_PRIVILEGES or by using the REVOKE statement if REVOKE_DEP_PRIVILEGES is set to SQLSTMT.

- If SECADM is removed from a user, grants that are made by this SECADM user are not revoked.

If this user revoked grants made by it, those revokes will continue to revoke the dependent privileges, unless the behavior to not include the dependent privileges was specified either by using the system parameter REVOKE_DEP_PRIVILEGES or by using the REVOKE statement if REVOKE_DEP_PRIVILEGES is set to SQLSTMT.

- If NOT INCLUDING DEPENDENT PRIVILEGES option is specified, the grants made by this user are not revoked.

Refer to the diagrams for the following example:

1. Suppose BOB grants SYSADM authority to WADE. Later, CLAIRE grants the SELECT privilege on a table with the WITH GRANT OPTION to WADE.

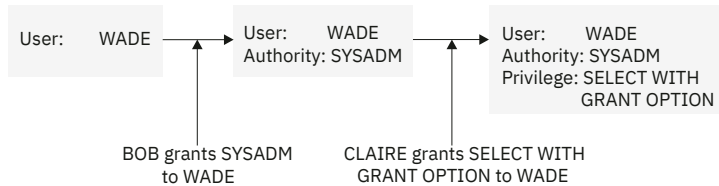

2. WADE grants the SELECT privilege to JOHN on the same table.

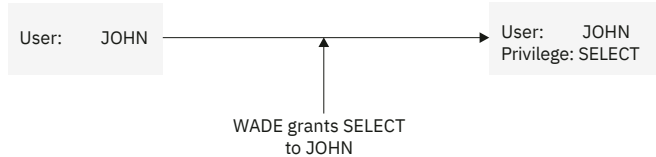

3. When CLAIRE revokes the SELECT privilege on the table from WADE, the SELECT privilege on that table is also revoked from JOHN.

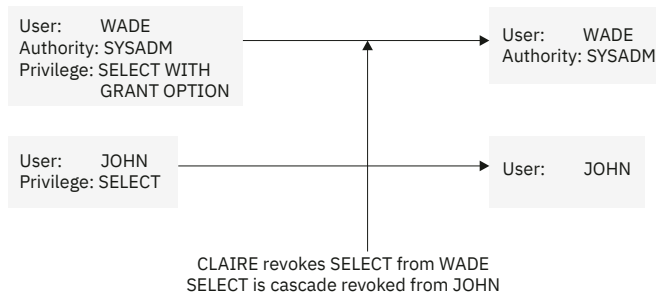

The grant from WADE to JOHN is removed because WADE had not been granted the SELECT privilege from any other source before CLAIRE made the grant. The SYSADM authority granted to WADE from BOB does not affect the cascade revoke. For more on SYSADM and installation SYSADM authority, see [Managing administrative authorities \(Managing Security\)](#). For another example of cascading revokes, see [Revoking privileges with the REVOKE statement \(Managing Security\)](#).

Revoking a SELECT privilege that was exercised to create a view or materialized query table causes the view to be dropped, unless the owner of the view was directly granted the SELECT privilege from another source before the view was created. Revoking a SYSADM privilege that was required to create a view causes the view to be dropped. For details on when SYSADM authority is required to create a view, see *Authorization* in [“CREATE VIEW statement”](#) on page 1812.

Invalidation of packages

A revoke or cascaded revoke of any privilege or role that was exercised to create a package makes the package invalid when the revokee no longer holds the privilege from any other source. Corresponding authorization caches are cleared even if the revokee has the privilege from any other source. For more information, see [Changes that invalidate packages \(Db2 Application programming and SQL\)](#).³⁷

Inoperative packages

A revoke or cascaded revoke of the EXECUTE privilege on a user-defined function that was exercised to create a package makes the package inoperative and causes the corresponding authorization caches to be cleared when the revokee no longer holds the privilege from any other source.³⁷

Privileges belonging to an authority

You can revoke an administrative authority, but you cannot separately revoke the specific privileges inherent in that administrative authority.

Let P be a privilege inherent in authority X. A user with authority X can also have privilege P as a result of an explicit grant of P. In this case:

- If X is revoked, the user still has privilege P.
- If P is revoked, the user still has the privilege because it is inherent in X.

Revoking of privileges in a trusted context

Revokes that are made in a trusted context that is defined with the `ROLE AS OBJECT OWNER` clause result in the revoker being the role in effect. If the statement is prepared dynamically, the revoker is the role that is associated with the user that is running the statement. If the statement is embedded in a program, the revoker is the owner of the plan or package. If the `ROLE AS OBJECT OWNER` clause is not specified for the trusted context, the revoker is the authorization ID of the process.

Ownership privileges

The privileges inherent in the ownership of an object cannot be revoked.

Revoke not including dependent privileges

When a privilege is revoked from a user by specifying `NOT INCLUDING DEPENDENT PRIVILEGES`, the grants that were made by this user are not revoked and the grantor remains unchanged. If that user is later granted the same privilege and then this privilege is revoked by specifying `INCLUDING DEPENDENT PRIVILEGES`, that would also revoke all the grants that were previously made by this user. Refer to the following examples:

User U1 is granted `SELECT` on table T1 with `GRANT OPTION`:

1. U1 grants this privilege to U2.
 2. `SELECT` privilege is revoked from U1 without including dependent privileges. As a result, the grant from U1 to U2 is not revoked.
 3. U1 is again granted `SELECT` on T1.
 4. `SELECT` is now revoked from U1 with including dependent privileges and the grant from U1 to U2 is now revoked.
- 1.

User U1 is granted `SYSADM` authority:

1. U1 grants privilege P1 to U2 and privilege P2 to U3.
 2. `SYSADM` is revoked from U1 without including dependent privileges. The grants of privileges P1 and P2 to U2 and U3 are not revoked.
 3. U1 is again granted `SYSADM`. U1 grants privilege P3 to U3.
 4. `SYSADM` is now revoked from U1 including dependent privileges. Now, P1 granted to U2 and P2 and P3 granted to U3 are also revoked.
- 1.

Related tasks

[Revoking privileges with the `REVOKE` statement \(Managing Security\)](#)

³⁷ Dependencies on stored procedures can be checked only if the procedure name is specified as a constant and not via a host variable in the `CALL` statement.

REVOKE statement (collection privileges)

This form of the REVOKE statement revokes privileges on collections.

Syntax for REVOKE (collection privileges)

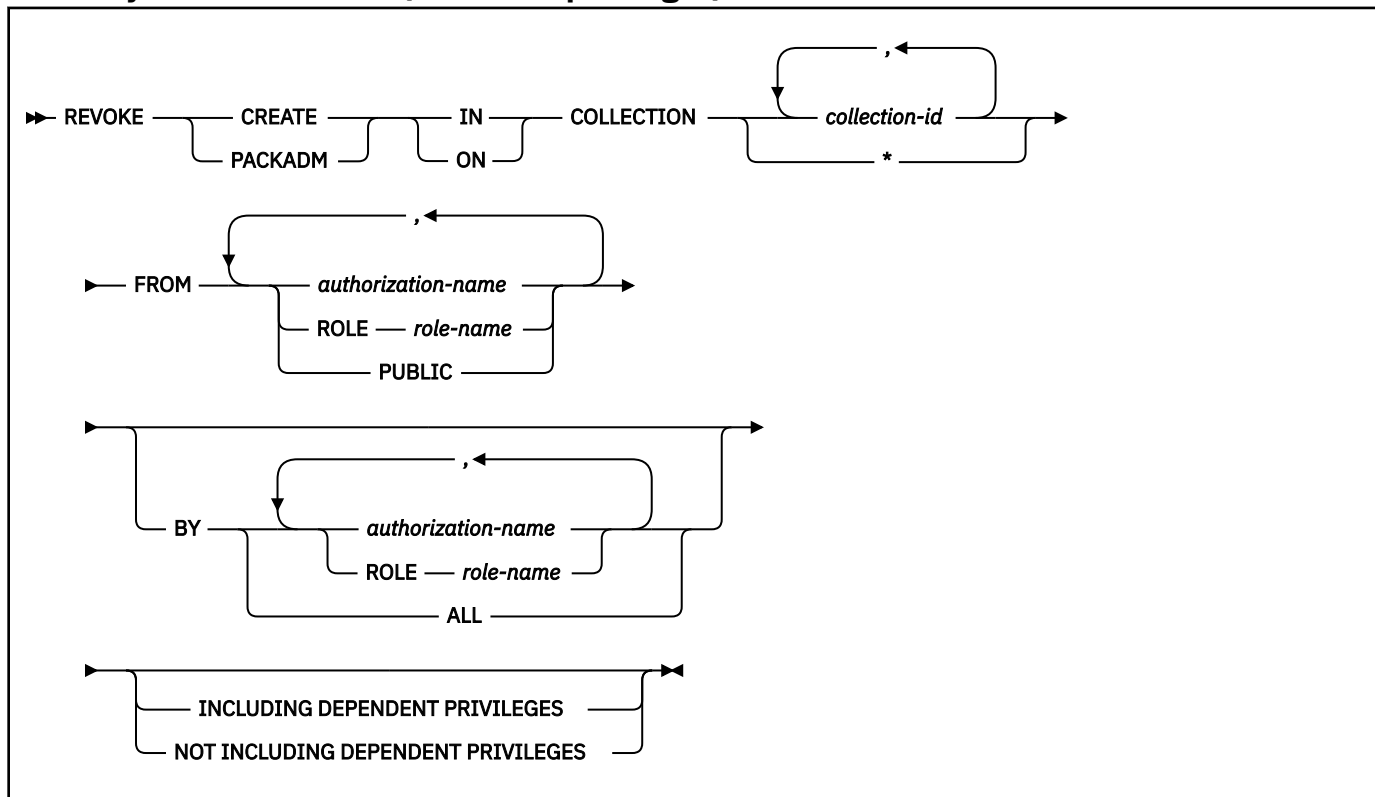

Description for REVOKE (collection privileges)

CREATE IN

Revokes the privilege to use the BIND subcommand to create packages in the designated collections.

The word ON can be used instead of IN.

PACKADM ON

Revokes the package administrator authority for the designated collections.

The word IN can be used instead of ON.

COLLECTION *collection-id*,...

Identifies the collections on which the specified privilege is revoked. For each identified collection, you (or the indicated grantors) must have granted the specified privilege on that collection to all identified users (including PUBLIC if specified). The same collection must not be identified more than once.

COLLECTION *

Indicates that the specified privilege on COLLECTION * is revoked. You (or the indicated grantors) must have granted the specified privilege on COLLECTION * to all identified users (including PUBLIC if specified). Privileges granted on specific collections are not affected.

FROM

Refer to [“REVOKE statement” on page 2070](#) for a description of the FROM clause.

BY

Refer to [“REVOKE statement” on page 2070](#) for a description of the BY clause.

INCLUDING DEPENDENT PRIVILEGES or NOT INCLUDING DEPENDENT PRIVILEGES

Specifies whether revoking a privilege or an authority from an authorization ID or a role also results in revoking the grants that were made by that user. The default value is based on the authority that is being revoked and the REVOKE_DEP_PRIVILEGES system parameter:

- When ACCESSCTRL, DATAACCESS, or system DBADM authority is revoked, NOT INCLUDING DEPENDENT PRIVILEGES is assumed and the clause must be specified on the REVOKE statement.
- When the REVOKE_DEP_PRIVILEGES system parameter is set to NO, NOT INCLUDING DEPENDENT PRIVILEGES is assumed and an error is returned if the statement includes INCLUDING DEPENDENT PRIVILEGES.
- Otherwise, INCLUDING DEPENDENT PRIVILEGES is assumed and the clause must be specified on the REVOKE statement.

INCLUDING DEPENDENT PRIVILEGES

Specifies that revoking a privilege or an authority from an authorization ID or a role also results in revoking dependent privileges. This means that any grants that were made by the user will continue to be revoked, until all grants in the chain have been revoked.

INCLUDING DEPENDENT PRIVILEGES cannot be specified if the system parameter REVOKE_DEP_PRIVILEGES is set to NO, which enforces the behavior to not include the dependent privileges.

NOT INCLUDING DEPENDENT PRIVILEGES

Specifies that revoking a privilege or an authority from an authorization ID or a role does not cause the grants that were made by the user to be revoked. However, for the revoked privileges, all implications of the privilege being revoked are applied. For example, if the revoked privileges were required to bind a package successfully, that package would continue to be invalidated as a result of the package owner losing these privileges. An object might be dropped if a privilege is revoked that was used to create the object.

NOT INCLUDING DEPENDENT PRIVILEGES must be specified when ACCESSCTRL, DATAACCESS, or system DBADM authority is revoked.

NOT INCLUDING DEPENDENT PRIVILEGES cannot be specified if the system parameter REVOKE_DEP_PRIVILEGES is set to YES, which enforces the behavior to include dependent privileges in the revoke.

Examples for REVOKE (collection privileges)

Example 1: Revoke the privilege to create new packages in collections QAACLONE and DSN8CC61 from CLARK.

```
REVOKE CREATE IN COLLECTION QAACLONE, DSN8CC61 FROM CLARK;
```

Example 2: Revoke the privilege to create new packages in collections DSN8CC91 from role ROLE1:

```
REVOKE CREATE IN COLLECTION DSN8CC91 FROM ROLE ROLE1;
```

REVOKE statement (database privileges)

This form of the REVOKE statement revokes database privileges.

Syntax for REVOKE (database privileges)

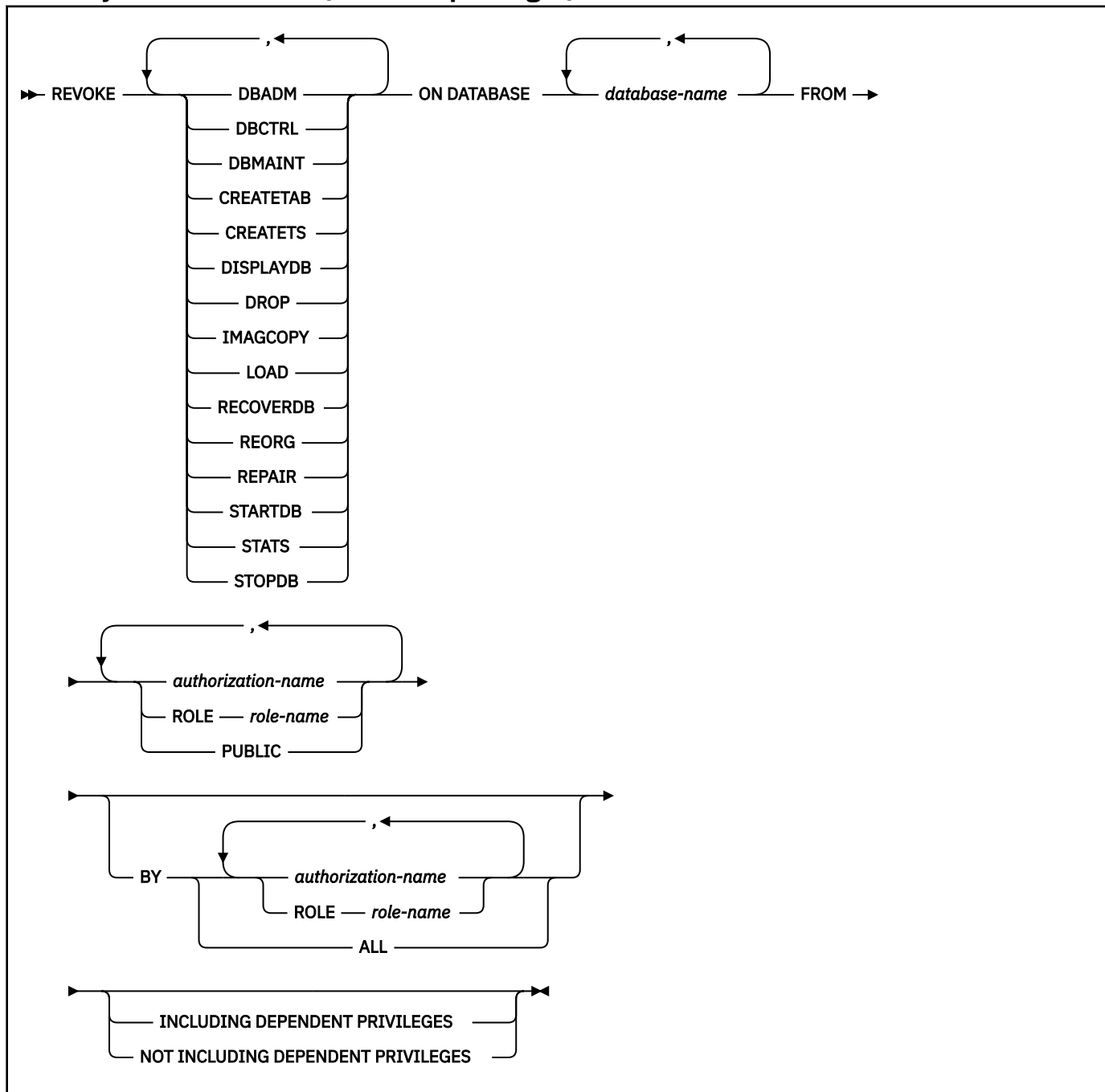

Description for REVOKE (database privileges)

Each keyword listed revokes the privilege described, but only as it applies to or within the databases named in the statement.

DBADM

Revokes the database administrator authority.

DBCTRL

Revokes the database control authority.

DBMAINT

Revokes the database maintenance authority.

CREATETAB

Revokes the privilege to create new tables. If CREATETAB privilege is revoked from DSNDB04, tables cannot be created in implicitly created databases. For a work file database, you cannot revoke the privilege from PUBLIC. When a work file database is created, PUBLIC implicitly receives the CREATETAB privilege (without GRANT authority); this privilege is not recorded in the Db2 catalog, and it cannot be revoked.

CREATETS

Revokes the privilege to create new table spaces.

DISPLAYDB

Revokes the privilege to issue the DISPLAY DATABASE command.

DROP

Revokes the privilege to issue the DROP or ALTER statements in the specified databases.

IMAGCOPY

Revokes the privilege to run the COPY, MERGECOPY, and QUIESCE utilities against table spaces of the specified databases, and to run the MODIFY RECOVERY utility.

LOAD

Revokes the privilege to use the LOAD utility to load tables.

RECOVERDB

Revokes the privilege to use the RECOVER and REPORT utilities to recover table spaces and indexes.

REORG

Revokes the privilege to use the REORG utility to reorganize table spaces and indexes.

REPAIR

Revokes the privilege to use the REPAIR and DIAGNOSE utilities.

STARTDB

Revokes the privilege to issue the START DATABASE command.

STATS

Revokes the privilege to use the RUNSTATS utility to update statistics, and the CHECK utility to test whether indexes are consistent with the data they index, and the MODIFY STATISTICS utility to delete unwanted statistics history records from the corresponding catalog tables.

STOPDB

Revokes the privilege to issue the STOP DATABASE command.

ON DATABASE *database-name*,...

Identifies databases on which you are revoking the privileges. For each database you identify, you (or the indicated grantors) must have granted at least one of the specified privileges on that database to all identified users (including PUBLIC, if specified). The same database must not be identified more than once.

FROM

Refer to [“REVOKE statement” on page 2070](#) for a description of the FROM clause.

BY

Refer to [“REVOKE statement” on page 2070](#) for a description of the BY clause.

INCLUDING DEPENDENT PRIVILEGES or NOT INCLUDING DEPENDENT PRIVILEGES

Specifies whether revoking a privilege or an authority from an authorization ID or a role also results in revoking the grants that were made by that user. The default value is based on the authority that is being revoked and the REVOKE_DEP_PRIVILEGES system parameter:

- When ACCESSCTRL, DATAACCESS, or system DBADM authority is revoked, NOT INCLUDING DEPENDENT PRIVILEGES is assumed and the clause must be specified on the REVOKE statement.
- When the REVOKE_DEP_PRIVILEGES system parameter is set to NO, NOT INCLUDING DEPENDENT PRIVILEGES is assumed and an error is returned if the statement includes INCLUDING DEPENDENT PRIVILEGES.

- Otherwise, `INCLUDING DEPENDENT PRIVILEGES` is assumed and the clause must be specified on the `REVOKE` statement.

INCLUDING DEPENDENT PRIVILEGES

Specifies that revoking a privilege or an authority from an authorization ID or a role also results in revoking dependent privileges. This means that any grants that were made by the user will continue to be revoked, until all grants in the chain have been revoked.

`INCLUDING DEPENDENT PRIVILEGES` cannot be specified if the system parameter `REVOKE_DEP_PRIVILEGES` is set to `NO`, which enforces the behavior to not include the dependent privileges.

NOT INCLUDING DEPENDENT PRIVILEGES

Specifies that revoking a privilege or an authority from an authorization ID or a role does not cause the grants that were made by the user to be revoked. However, for the revoked privileges, all implications of the privilege being revoked are applied. For example, if the revoked privileges were required to bind a package successfully, that package would continue to be invalidated as a result of the package owner losing these privileges. An object might be dropped if a privilege is revoked that was used to create the object.

`NOT INCLUDING DEPENDENT PRIVILEGES` must be specified when `ACCESSCTRL`, `DATAACCESS`, or system `DBADM` authority is revoked.

`NOT INCLUDING DEPENDENT PRIVILEGES` cannot be specified if the system parameter `REVOKE_DEP_PRIVILEGES` is set to `YES`, which enforces the behavior to include dependent privileges in the revoke.

Examples for REVOKE (database privileges)

Example 1: Revoke drop privileges on database DSN8D12A from user PEREZ.

```
REVOKE DROP
ON DATABASE DSN8D12A
FROM PEREZ;
```

Example 2: Revoke repair privileges on database DSN8D12A from all local users. (Grants to specific users will not be affected.)

```
REVOKE REPAIR
ON DATABASE DSN8D12A
FROM PUBLIC;
```

Example 3: Revoke authority to create new tables and load tables in database DSN8D12A from users WALKER, PIANKA, and FUJIMOTO.

```
REVOKE CREATETAB,LOAD
ON DATABASE DSN8D12A
FROM WALKER,PIANKA,FUJIMOTO;
```

Example 4: Revoke load privileges on database DSN8D12A from role ROLE1:

```
REVOKE LOAD
ON DATABASE DSN8D12A
FROM ROLE ROLE1;
```

REVOKE statement (function or procedure privileges)

This form of the REVOKE statement revokes privileges on user-defined functions, cast functions that were generated for distinct types, and stored procedures.

Syntax for REVOKE (function or procedure privileges)

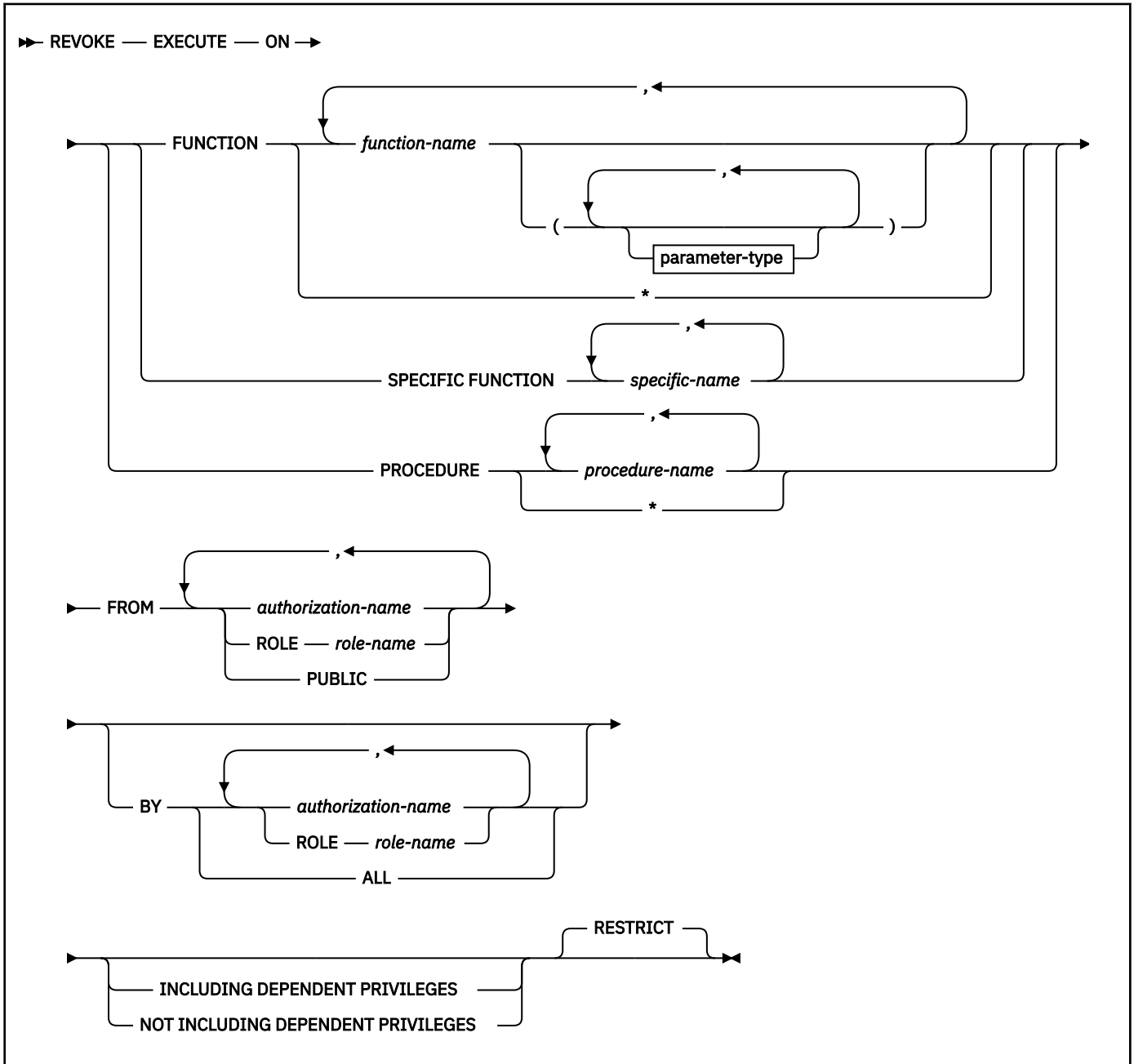

parameter-type:

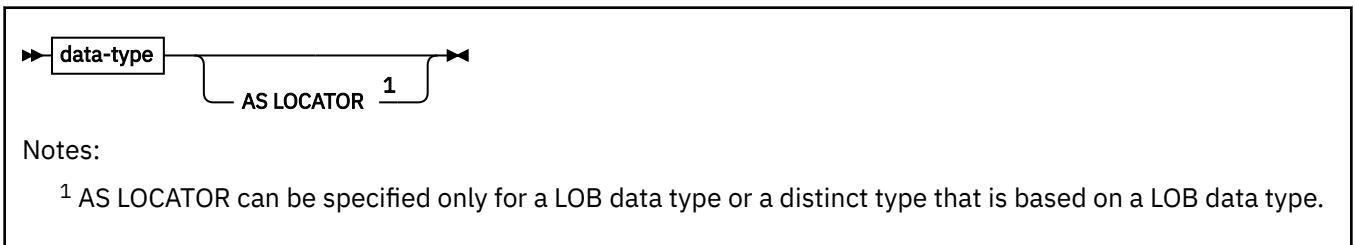

data-type:



built-in-type:

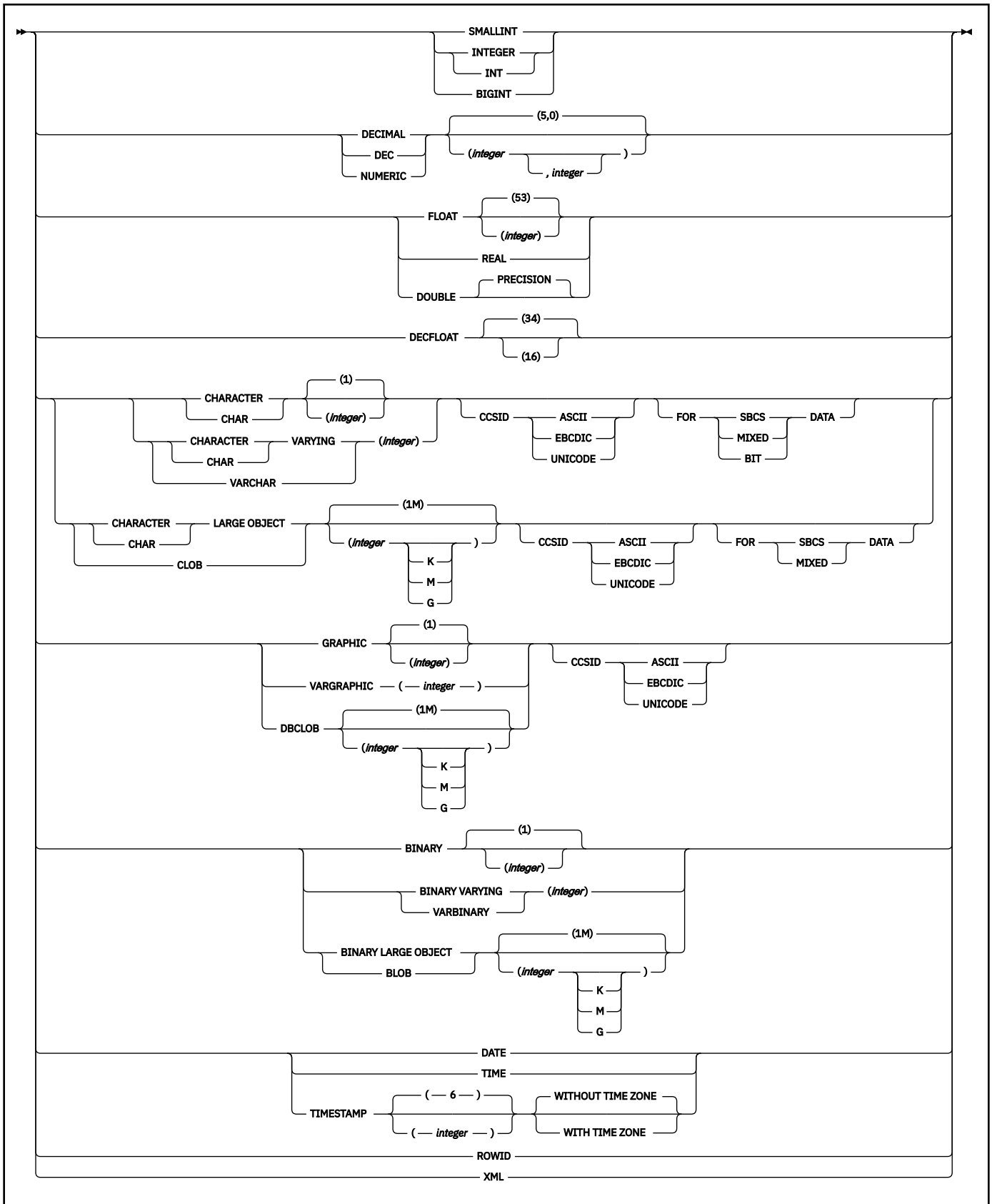

Description for REVOKE (function or procedure privileges)

EXECUTE

Revokes the privilege to run the identified user-defined function, cast function that was generated for a distinct type, or stored procedure.

FUNCTION or SPECIFIC FUNCTION

Identifies the function from which the privilege is revoked. The function must exist at the current server, and it must be a function that was defined with the CREATE FUNCTION statement or a cast function that was generated by a CREATE TYPE statement. The function can be identified by name, function signature, or specific name.

If the function was defined with a table parameter (the LIKE TABLE was specified in the CREATE FUNCTION statement to indicate that one of the input parameters is a transition table), the function signature cannot be used to identify the function. Instead, identify the function with its function name, if unique, or with its specific name.

FUNCTION *function-name*

Identifies the function by its name. The *function-name* must identify exactly one function. The function can have any number of parameters defined for it. If there is more than one function of the specified name in the specified or implicit schema, an error is returned.

An * can be specified for a qualified or unqualified *function-name*. An * (or *schema-name.**) indicates that the privilege is revoked for all the functions in the schema. You (or the indicated grantors) must have granted the privilege on FUNCTION * to all identified users (including PUBLIC if specified). Privileges granted on specific functions are not affected.

FUNCTION *function-name (parameter-type,...)*

Identifies the function by its function signature, which uniquely identifies the function. The *function-name (parameter-type, ...)* must identify a function with the specified function signature. The specified parameters must match the data types in the corresponding position that were specified when the function was created. The number of data types, and the logical concatenation of the data types is used to identify the specific function instance on which the privilege is to be granted. Synonyms for data types are considered a match.

If the function was defined with a table parameter (the LIKE TABLE *name* AS LOCATOR clause was specified in the CREATE FUNCTION statement to indicate that one of the input parameters is a transition table), the function signature cannot be used to uniquely identify the function. Instead, use one of the other syntax variations to identify the function with its function name, if unique, or its specific name.

If *function-name ()* is specified, the function identified must have zero parameters.

function-name

Identifies the name of the function. If you do not explicitly qualify the function name with a schema name, the function name is implicitly qualified with a schema name as described in the preceding description for FUNCTION *function-name*.

(parameter-type,...)

Identifies the parameters of the function.

If an unqualified distinct type name is specified, Db2 searches the SQL path to resolve the schema name for the distinct type.

For data types that have a length, precision, or scale attribute, use one of the following:

- Empty parentheses indicate that the database manager ignores the attribute when determining whether the data types match. For example, DEC() will be considered a match for a parameter of a function defined with a data type of DEC(7,2). Similarly DECFLOAT() will be considered a match for DECFLOAT(16) or DECFLOAT(34). However, FLOAT cannot be specified with empty parenthesis because its parameter value indicates a specific data type (REAL or DOUBLE).
- If a specific value for a length, precision, or scale attribute is specified, the value must exactly match the value that was specified (implicitly or explicitly) in the CREATE FUNCTION

statement. If the data type is FLOAT, the precision does not have to exactly match the value that was specified because matching is based on the data type (REAL or DOUBLE).

- If length, precision, or scale is not explicitly specified, and empty parentheses are not specified, the default attributes of the data type are implied. The implicit length must exactly match the value that was specified (implicitly or explicitly) in the CREATE FUNCTION statement.

For data types with a subtype or encoding scheme attribute, specifying the FOR *subtype* DATA clause or the CCSID clause is optional. Omission of either clause indicates that Db2 ignores the attribute when determining whether the data types match. If you specify either clause, it must match the value that was implicitly or explicitly specified in the CREATE FUNCTION statement.

AS LOCATOR

Specifies that the function is defined to receive a locator for this parameter. If AS LOCATOR is specified, the data type must be a LOB or a distinct type based on a LOB.

SPECIFIC FUNCTION *specific-name*

Identifies the function by its specific name. The *specific-name* must identify a specific function that exists at the current server.

PROCEDURE *procedure-name*

Identifies a stored procedure that is defined at the current server.

An * can be specified for a qualified or unqualified *procedure-name*. An * (or *schema-name.**) indicates that the privilege is revoked for all the procedures in the schema. You (or the indicated grantors) must have granted the privilege on PROCEDURE * to all identified users (including PUBLIC if specified). Privileges granted on specific procedures are not affected.

FROM

Refer to [“REVOKE statement” on page 2070](#) for a description of the FROM clause.

BY

Refer to [“REVOKE statement” on page 2070](#) for a description of the BY clause.

INCLUDING DEPENDENT PRIVILEGES or NOT INCLUDING DEPENDENT PRIVILEGES

Specifies whether revoking a privilege or an authority from an authorization ID or a role also results in revoking the grants that were made by that user. The default value is based on the authority that is being revoked and the REVOKE_DEP_PRIVILEGES system parameter:

- When ACCESSCTRL, DATAACCESS, or system DBADM authority is revoked, NOT INCLUDING DEPENDENT PRIVILEGES is assumed and the clause must be specified on the REVOKE statement.
- When the REVOKE_DEP_PRIVILEGES system parameter is set to NO, NOT INCLUDING DEPENDENT PRIVILEGES is assumed and an error is returned if the statement includes INCLUDING DEPENDENT PRIVILEGES.
- Otherwise, INCLUDING DEPENDENT PRIVILEGES is assumed and the clause must be specified on the REVOKE statement.

INCLUDING DEPENDENT PRIVILEGES

Specifies that revoking a privilege or an authority from an authorization ID or a role also results in revoking dependent privileges. This means that any grants that were made by the user will continue to be revoked, until all grants in the chain have been revoked.

INCLUDING DEPENDENT PRIVILEGES cannot be specified if the system parameter REVOKE_DEP_PRIVILEGES is set to NO, which enforces the behavior to not include the dependent privileges.

NOT INCLUDING DEPENDENT PRIVILEGES

Specifies that revoking a privilege or an authority from an authorization ID or a role does not cause the grants that were made by the user to be revoked. However, for the revoked privileges, all implications of the privilege being revoked are applied. For example, if the revoked privileges were required to bind a package successfully, that package would continue to be invalidated as a result

of the package owner losing these privileges. An object might be dropped if a privilege is revoked that was used to create the object.

NOT INCLUDING DEPENDENT PRIVILEGES must be specified when ACCESSCTRL, DATAACCESS, or system DBADM authority is revoked.

NOT INCLUDING DEPENDENT PRIVILEGES cannot be specified if the system parameter REVOKE_DEP_PRIVILEGES is set to YES, which enforces the behavior to include dependent privileges in the revoke.

RESTRICT

Prevents the EXECUTE privilege from being revoked on a user-defined function or stored procedure if the revokee owns any of the following objects and does not have the EXECUTE privilege from another source:

- A function that is sourced on the function
- A view that uses the function
- A trigger package that uses the function or stored procedure
- A table that uses the function in a check constraint or user-defined default clause
- A materialized query table whose fullselect uses the function
- An extended index that uses the function

Examples for REVOKE (function or procedure privileges)

Example 1: Revoke the EXECUTE privilege on function CALC_SALARY for user JONES. Assume that there is only one function in the schema with function CALC_SALARY.

```
REVOKE EXECUTE ON FUNCTION CALC_SALARY FROM JONES;
```

Example 2: Revoke the EXECUTE privilege on procedure VACATION_ACCR from all users at the current server.

```
REVOKE EXECUTE ON PROCEDURE VACATION_ACCR FROM PUBLIC;
```

Example 3: Revoke the privilege of the administrative assistant to grant EXECUTE privileges on function DEPT_TOTAL to other users. The administrative assistant will still have the EXECUTE privilege on function DEPT_TOTALS.

```
REVOKE EXECUTE ON FUNCTION DEPT_TOTALS  
FROM ADMIN_A;
```

Example 4: Revoke the EXECUTE privilege on function NEW_DEPT_HIRES for HR (Human Resources). The function has two input parameters with data types of INTEGER and CHAR(10), respectively. Assume that the schema has more than one function that is named NEW_DEPT_HIRES.

```
REVOKE EXECUTE ON FUNCTION NEW_DEPT_HIRES (INTEGER, CHAR(10))  
FROM HR;
```

You can also code the CHAR(10) data type as CHAR().

Example 5: Revoke the EXECUTE privilege on function FIND_EMPDEPT from role ROLE1:

```
REVOKE EXECUTE ON FUNCTION FIND_EMPDEPT  
FROM ROLE ROLE1;
```

REVOKE statement (package privileges)

This form of the REVOKE statement revokes privileges on packages.

Syntax for REVOKE (package privileges)

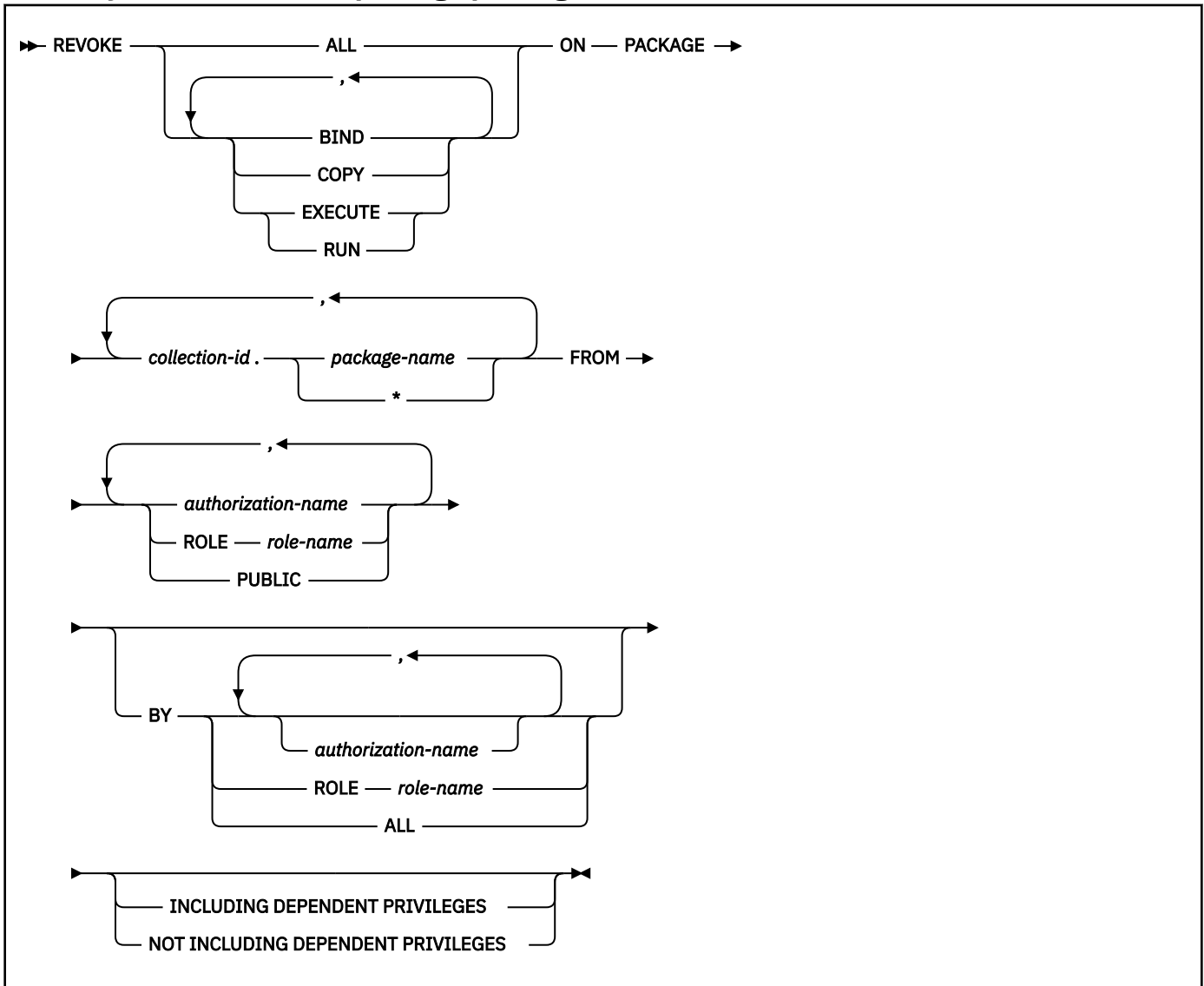

Description for REVOKE (package privileges)

BIND

Revokes the privilege to use the BIND and REBIND subcommands for the designated packages. In addition, if the value of field BIND NEW PACKAGE on installation panel DSNTIPP is BIND, the additional BIND privilege of adding new versions of packages is revoked. (For details, see [“GRANT statement \(package privileges\)”](#) on page 1975.)

COPY

Revokes the privilege to use the COPY option of the BIND subcommand for the designated packages.

EXECUTE

Revokes the privilege to run application programs that use the designated packages and to specify the packages following PKLIST for the BIND PLAN and REBIND PLAN commands. RUN is an alternate name for the same privilege.

ALL

Revokes all package privileges for which you have authority for the packages named in the ON clause.

ON PACKAGE *collection-id.package-name,...*

Identifies packages for which you are revoking privileges. The revoking of a package privilege applies to all versions of that package. For each package that you identify, you (or the indicated grantors) must have granted at least one of the specified privileges on that package to all identified users (including PUBLIC, if specified). An authorization ID with PACKADM authority over the collection or all collections, SYSADM, or SYSCTRL authority can specify all packages in the collection by using * for *package-name*. The same package must not be specified more than once.

FROM

Refer to [“REVOKE statement” on page 2070](#) for a description of the FROM clause.

BY

Refer to [“REVOKE statement” on page 2070](#) for a description of the BY clause.

INCLUDING DEPENDENT PRIVILEGES or NOT INCLUDING DEPENDENT PRIVILEGES

Specifies whether revoking a privilege or an authority from an authorization ID or a role also results in revoking the grants that were made by that user. The default value is based on the authority that is being revoked and the REVOKE_DEP_PRIVILEGES system parameter:

- When ACCESSCTRL, DATAACCESS, or system DBADM authority is revoked, NOT INCLUDING DEPENDENT PRIVILEGES is assumed and the clause must be specified on the REVOKE statement.
- When the REVOKE_DEP_PRIVILEGES system parameter is set to NO, NOT INCLUDING DEPENDENT PRIVILEGES is assumed and an error is returned if the statement includes INCLUDING DEPENDENT PRIVILEGES.
- Otherwise, INCLUDING DEPENDENT PRIVILEGES is assumed and the clause must be specified on the REVOKE statement.

INCLUDING DEPENDENT PRIVILEGES

Specifies that revoking a privilege or an authority from an authorization ID or a role also results in revoking dependent privileges. This means that any grants that were made by the user will continue to be revoked, until all grants in the chain have been revoked.

INCLUDING DEPENDENT PRIVILEGES cannot be specified if the system parameter REVOKE_DEP_PRIVILEGES is set to NO, which enforces the behavior to not include the dependent privileges.

NOT INCLUDING DEPENDENT PRIVILEGES

Specifies that revoking a privilege or an authority from an authorization ID or a role does not cause the grants that were made by the user to be revoked. However, for the revoked privileges, all implications of the privilege being revoked are applied. For example, if the revoked privileges were required to bind a package successfully, that package would continue to be invalidated as a result of the package owner losing these privileges. An object might be dropped if a privilege is revoked that was used to create the object.

NOT INCLUDING DEPENDENT PRIVILEGES must be specified when ACCESSCTRL, DATAACCESS, or system DBADM authority is revoked.

NOT INCLUDING DEPENDENT PRIVILEGES cannot be specified if the system parameter REVOKE_DEP_PRIVILEGES is set to YES, which enforces the behavior to include dependent privileges in the revoke.

Notes for REVOKE (package privileges)

Alternative syntax and synonyms: To provide compatibility with previous releases of Db2 or other products in the Db2 family, Db2 supports specifying PROGRAM as a synonym for PACKAGE.

Examples for REVOKE (package privileges)

Example 1: Revoke the privilege to copy all packages in collection DSN8CC61 from LEWIS.

```
REVOKE COPY ON PACKAGE DSN8CC61.* FROM LEWIS;
```

Example 2: Revoke the privilege to run all packages in collection DSN9CC13 from role ROLE1:

```
REVOKE EXECUTE ON PACKAGE DSN9CC13.* FROM ROLE ROLE1;
```

REVOKE statement (plan privileges)

This form of the REVOKE statement revokes privileges on application plans.

Syntax for REVOKE (plan privileges)

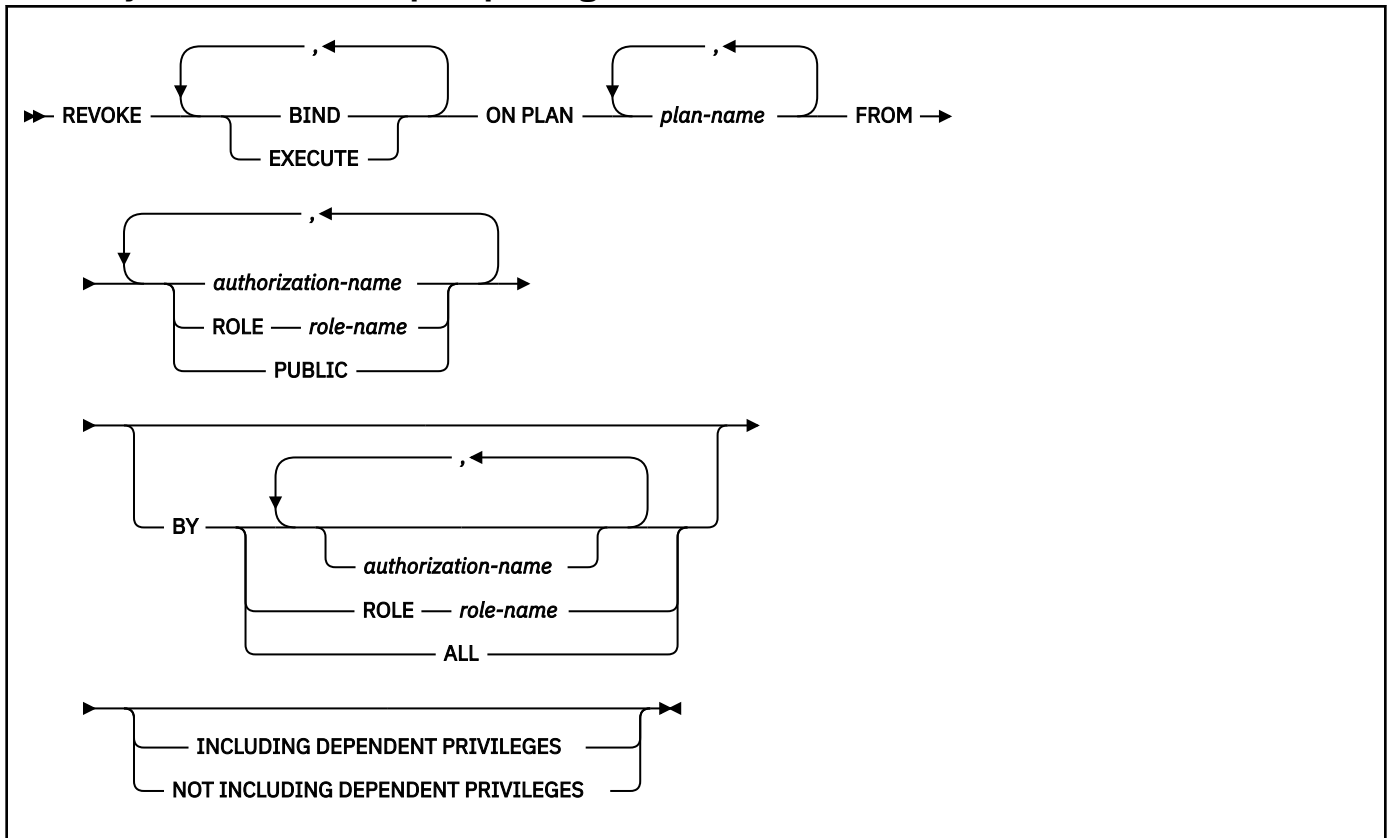

Description for REVOKE (plan privileges)

BIND

Revokes the privilege to use the BIND, REBIND, and FREE subcommands for the identified plans.

EXECUTE

Revokes the privilege to run application programs that use the identified plans.

ON PLAN *plan-name*,...

Identifies application plans for which you are revoking privileges. For each plan that you identify, you (or the indicated grantors) must have granted at least one of the specified privileges on that plan to all identified users (including PUBLIC, if specified). The same plan must not be specified more than once.

FROM

Refer to [“REVOKE statement” on page 2070](#) for a description of the FROM clause.

BY

Refer to [“REVOKE statement” on page 2070](#) for a description of the BY clause.

INCLUDING DEPENDENT PRIVILEGES or NOT INCLUDING DEPENDENT PRIVILEGES

Specifies whether revoking a privilege or an authority from an authorization ID or a role also results in revoking the grants that were made by that user. The default value is based on the authority that is being revoked and the REVOKE_DEP_PRIVILEGES system parameter:

- When ACCESSCTRL, DATAACCESS, or system DBADM authority is revoked, NOT INCLUDING DEPENDENT PRIVILEGES is assumed and the clause must be specified on the REVOKE statement.
- When the REVOKE_DEP_PRIVILEGES system parameter is set to NO, NOT INCLUDING DEPENDENT PRIVILEGES is assumed and an error is returned if the statement includes INCLUDING DEPENDENT PRIVILEGES.
- Otherwise, INCLUDING DEPENDENT PRIVILEGES is assumed and the clause must be specified on the REVOKE statement.

INCLUDING DEPENDENT PRIVILEGES

Specifies that revoking a privilege or an authority from an authorization ID or a role also results in revoking dependent privileges. This means that any grants that were made by the user will continue to be revoked, until all grants in the chain have been revoked.

INCLUDING DEPENDENT PRIVILEGES cannot be specified if the system parameter REVOKE_DEP_PRIVILEGES is set to NO, which enforces the behavior to not include the dependent privileges.

NOT INCLUDING DEPENDENT PRIVILEGES

Specifies that revoking a privilege or an authority from an authorization ID or a role does not cause the grants that were made by the user to be revoked. However, for the revoked privileges, all implications of the privilege being revoked are applied. For example, if the revoked privileges were required to bind a package successfully, that package would continue to be invalidated as a result of the package owner losing these privileges. An object might be dropped if a privilege is revoked that was used to create the object.

NOT INCLUDING DEPENDENT PRIVILEGES must be specified when ACCESSCTRL, DATAACCESS, or system DBADM authority is revoked.

NOT INCLUDING DEPENDENT PRIVILEGES cannot be specified if the system parameter REVOKE_DEP_PRIVILEGES is set to YES, which enforces the behavior to include dependent privileges in the revoke.

Examples for REVOKE (plan privileges)

Example 1: Revoke authority to bind plan DSN8IP12 from user JONES.

```
REVOKE BIND ON PLAN DSN8IP12 FROM JONES;
```

Example 2: Revoke authority previously granted to all users at the current server to bind and execute plan DSN8CP12. (Grants to specific users will not be affected.)

```
REVOKE BIND,EXECUTE ON PLAN DSN8CP12 FROM PUBLIC;
```

Example 3: Revoke authority to execute plan DSN8CP12 from users ADAMSON and BROWN.

```
REVOKE EXECUTE ON PLAN DSN8CP12 FROM ADAMSON,BROWN;
```

Example 4: Revoke authority to bind plan DSN91PLN from role ROLE1:

```
REVOKE BIND ON PLAN DSN91PLN FROM ROLE ROLE1;
```

REVOKE statement (schema privileges)

This form of the REVOKE statement revokes privileges on schemas.

Syntax for REVOKE (schema privileges)

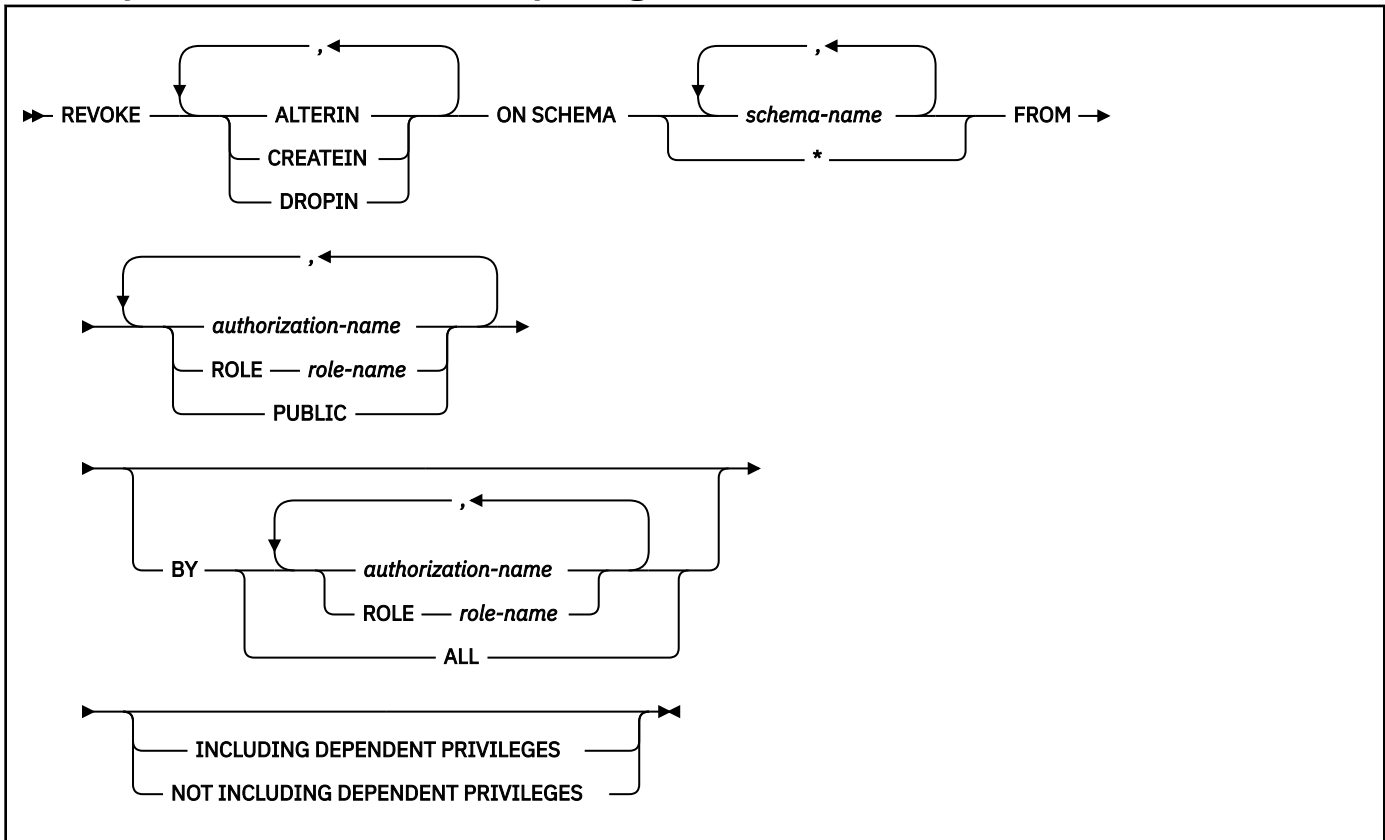

Description for REVOKE (schema privileges)

ALTERIN

Revokes the privilege to alter sequences, stored procedures, and user-defined functions, or specify a comment for distinct types, cast functions that are generated for distinct types, sequences, stored procedures, triggers, and user-defined functions in the designated schemas.

CREATEIN

Revokes the privilege to create distinct types, sequences, stored procedures, triggers, and user-defined functions in the designated schemas.

DROPIN

Revokes the privilege to drop distinct types, sequences, stored procedures, triggers, and user-defined functions in the designated schemas.

SCHEMA *schema-name*

Identifies the schema on which the privilege is revoked.

SCHEMA *

Indicates that the specified privilege on all schemas is revoked. You (or the indicated grantors) must have previously granted the specified privilege on SCHEMA * to all identified users (including PUBLIC if specified). Privileges granted on specific schemas are not affected.

FROM

Refer to [“REVOKE statement” on page 2070](#) for a description of the FROM clause.

BY

Refer to [“REVOKE statement” on page 2070](#) for a description of the BY clause.

INCLUDING DEPENDENT PRIVILEGES or NOT INCLUDING DEPENDENT PRIVILEGES

Specifies whether revoking a privilege or an authority from an authorization ID or a role also results in revoking the grants that were made by that user. The default value is based on the authority that is being revoked and the REVOKE_DEP_PRIVILEGES system parameter:

- When ACCESSCTRL, DATAACCESS, or system DBADM authority is revoked, NOT INCLUDING DEPENDENT PRIVILEGES is assumed and the clause must be specified on the REVOKE statement.
- When the REVOKE_DEP_PRIVILEGES system parameter is set to NO, NOT INCLUDING DEPENDENT PRIVILEGES is assumed and an error is returned if the statement includes INCLUDING DEPENDENT PRIVILEGES.
- Otherwise, INCLUDING DEPENDENT PRIVILEGES is assumed and the clause must be specified on the REVOKE statement.

INCLUDING DEPENDENT PRIVILEGES

Specifies that revoking a privilege or an authority from an authorization ID or a role also results in revoking dependent privileges. This means that any grants that were made by the user will continue to be revoked, until all grants in the chain have been revoked.

INCLUDING DEPENDENT PRIVILEGES cannot be specified if the system parameter REVOKE_DEP_PRIVILEGES is set to NO, which enforces the behavior to not include the dependent privileges.

NOT INCLUDING DEPENDENT PRIVILEGES

Specifies that revoking a privilege or an authority from an authorization ID or a role does not cause the grants that were made by the user to be revoked. However, for the revoked privileges, all implications of the privilege being revoked are applied. For example, if the revoked privileges were required to bind a package successfully, that package would continue to be invalidated as a result of the package owner losing these privileges. An object might be dropped if a privilege is revoked that was used to create the object.

NOT INCLUDING DEPENDENT PRIVILEGES must be specified when ACCESSCTRL, DATAACCESS, or system DBADM authority is revoked.

NOT INCLUDING DEPENDENT PRIVILEGES cannot be specified if the system parameter REVOKE_DEP_PRIVILEGES is set to YES, which enforces the behavior to include dependent privileges in the revoke.

Examples for REVOKE (schema privileges)

Example 1: Revoke the CREATEIN privilege on schema T_SCORES from user JONES.

```
REVOKE CREATEIN ON SCHEMA T_SCORES FROM JONES;
```

Example 2: Revoke the CREATEIN privilege on schema VAC from all users at the current server.

```
REVOKE CREATEIN ON SCHEMA VAC FROM PUBLIC;
```

Example 3: Revoke the ALTERIN privilege on schema DEPT from the administrative assistant.

```
REVOKE ALTERIN ON SCHEMA DEPT FROM ADMIN_A;
```

Example 4: Revoke the ALTERIN and DROPIN privileges on schemas NEW_HIRE, PROMO, and RESIGN from HR (Human Resources).

```
REVOKE ALTERIN, DROPIN ON SCHEMA NEW_HIRE, PROMO, RESIGN FROM HR;
```

Example 5: Revoke the ALTERIN privilege on schemas EMPLOYEE from role ROLE1:

```
REVOKE ALTERIN ON SCHEMA EMPLOYEE FROM ROLE ROLE1;
```

REVOKE statement (sequence privileges)

This form of the REVOKE statement revokes the privileges on a user-defined sequence.

Syntax for REVOKE (sequence privileges)

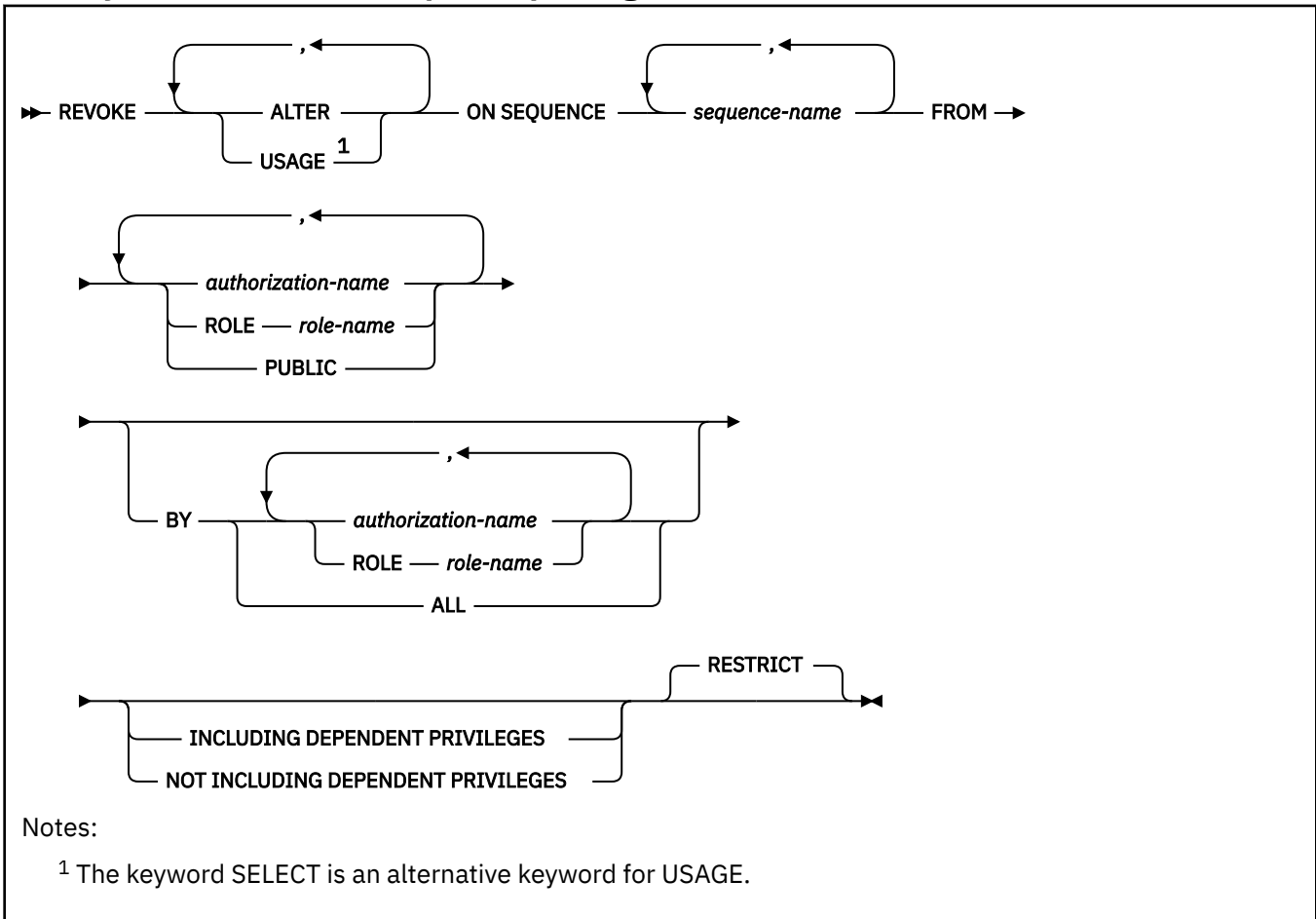

Description for REVOKE (sequence privileges)

ALTER

Revokes the privilege to alter a sequence or record a comment on a sequence.

USAGE

Revokes the USAGE privilege to use a sequence. This privilege is needed when the NEXT VALUE or PREVIOUS VALUE expression is invoked for a sequence name.

SEQUENCE *sequence-name*

Identifies the sequence. The name, including the implicit or explicit schema qualifier, must uniquely identify an existing sequence at the current server. If no sequence by this name exists in the explicitly or implicitly specified schema, an error occurs. *sequence-name* must not be the name of an internal sequence object that is generated by the system for an identity column.

FROM

Refer to “REVOKE statement” on page 2070 for a description of the FROM clause.

BY

Refer to “REVOKE statement” on page 2070 for a description of the BY clause.

INCLUDING DEPENDENT PRIVILEGES or NOT INCLUDING DEPENDENT PRIVILEGES

Specifies whether revoking a privilege or an authority from an authorization ID or a role also results in revoking the grants that were made by that user. The default value is based on the authority that is being revoked and the REVOKE_DEP_PRIVILEGES system parameter:

- When ACCESSCTRL, DATAACCESS, or system DBADM authority is revoked, NOT INCLUDING DEPENDENT PRIVILEGES is assumed and the clause must be specified on the REVOKE statement.
- When the REVOKE_DEP_PRIVILEGES system parameter is set to NO, NOT INCLUDING DEPENDENT PRIVILEGES is assumed and an error is returned if the statement includes INCLUDING DEPENDENT PRIVILEGES.
- Otherwise, INCLUDING DEPENDENT PRIVILEGES is assumed and the clause must be specified on the REVOKE statement.

INCLUDING DEPENDENT PRIVILEGES

Specifies that revoking a privilege or an authority from an authorization ID or a role also results in revoking dependent privileges. This means that any grants that were made by the user will continue to be revoked, until all grants in the chain have been revoked.

INCLUDING DEPENDENT PRIVILEGES cannot be specified if the system parameter REVOKE_DEP_PRIVILEGES is set to NO, which enforces the behavior to not include the dependent privileges.

NOT INCLUDING DEPENDENT PRIVILEGES

Specifies that revoking a privilege or an authority from an authorization ID or a role does not cause the grants that were made by the user to be revoked. However, for the revoked privileges, all implications of the privilege being revoked are applied. For example, if the revoked privileges were required to bind a package successfully, that package would continue to be invalidated as a result of the package owner losing these privileges. An object might be dropped if a privilege is revoked that was used to create the object.

NOT INCLUDING DEPENDENT PRIVILEGES must be specified when ACCESSCTRL, DATAACCESS, or system DBADM authority is revoked.

NOT INCLUDING DEPENDENT PRIVILEGES cannot be specified if the system parameter REVOKE_DEP_PRIVILEGES is set to YES, which enforces the behavior to include dependent privileges in the revoke.

RESTRICT

Prevents the USAGE privilege from being revoked on a sequence if the revokee owns one of the following objects and does not have the USAGE privilege from another source:

- A trigger that specifies the sequence in a NEXT VALUE or PREVIOUS VALUE expression
- An inline SQL function that specifies the sequence in a NEXT VALUE or PREVIOUS VALUE expression

Examples for REVOKE (sequence privileges)

Example 1: Revoke USAGE privilege on sequence MYNUM to user JONES.

```
REVOKE USAGE
ON SEQUENCE MYNUM
FROM JONES;
```

Example 2: Revoke the USAGE privilege on sequence ORDER_SEQ from role ROLE1:

```
REVOKE USAGE
ON SEQUENCE ORDER_SEQ
FROM ROLE ROLE1;
```

REVOKE statement (system privileges)

This form of the REVOKE statement revokes system privileges.

Syntax for REVOKE (system privileges)

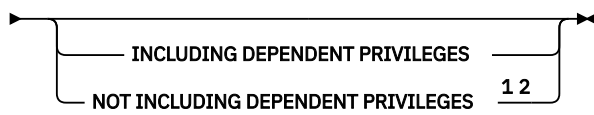
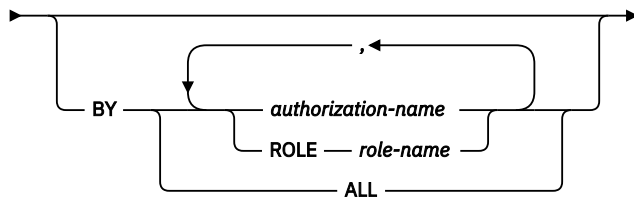
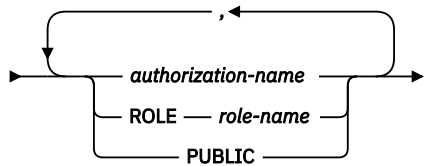
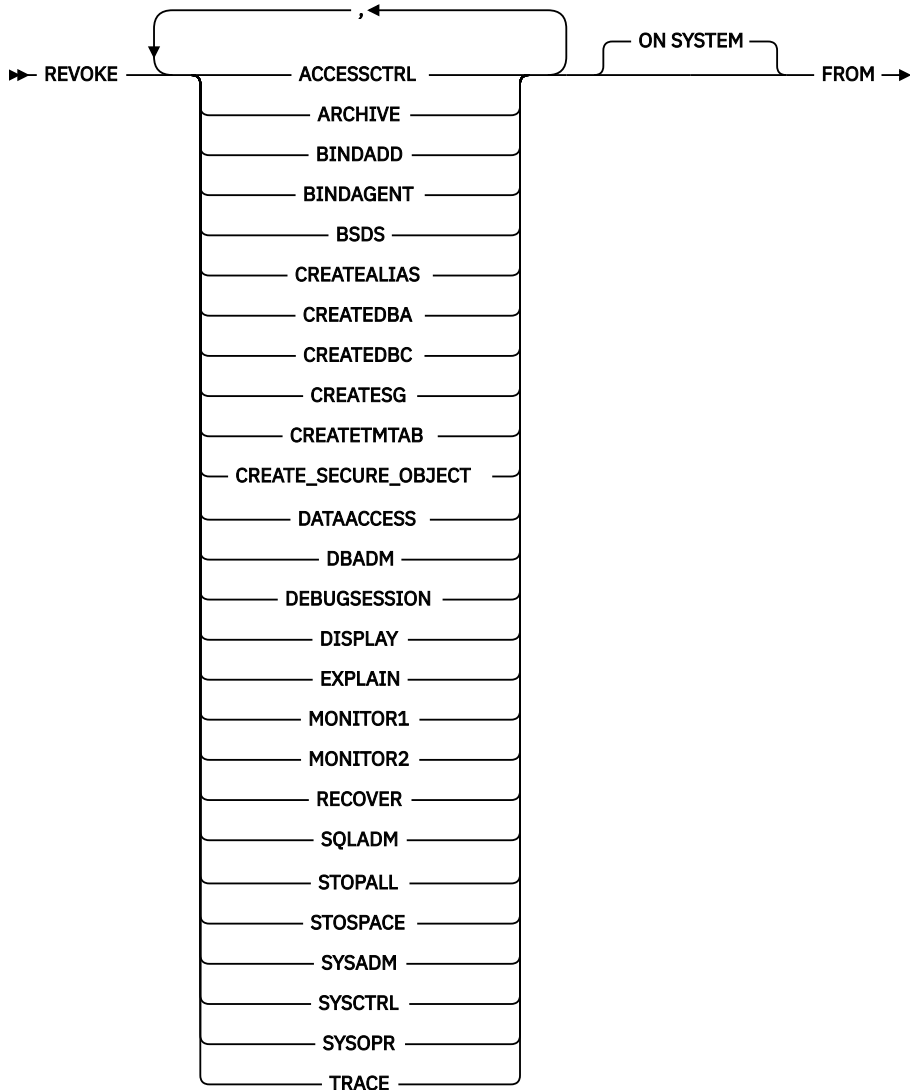

12

Notes:

¹ INCLUDING DEPENDENT PRIVILEGES must not be specified when ACCESSCTRL, DATAACCESS, or DBADM is specified.

² NOT INCLUDING DEPENDENT PRIVILEGES must be specified when ACCESSCTRL, DATAACCESS, or DBADM is specified

Description for REVOKE (system privileges)

ACCESSCTRL

Revokes the ACCESSCTRL authority, but does not revoke any privileges that are dependent on it.

ARCHIVE

Revokes the privilege to use the ARCHIVE LOG command.

BINDADD

Revokes the privilege to create plans and packages using the BIND subcommand with the ADD option.

BINDAGENT

Revokes the privilege to issue the BIND, FREE PACKAGE, or REBIND subcommands for plans and packages and the DROP PACKAGE statement on behalf of the grantor. The privilege also allows the holder to copy and replace plans and packages on behalf of the grantor.

A revoke of this privilege does not cascade.

BSDS

Revokes the privilege to issue the RECOVER BSDS command.

CREATEALIAS

Revokes the privilege to use the CREATE ALIAS statement.

CREATEDBA

Revokes the privilege to issue the CREATE DATABASE statement and acquire DBADM authority over those databases.

CREATEDBC

Revokes the privilege to issue the CREATE DATABASE statement and acquire DBCTRL authority over those databases.

CREATESG

Revokes the privilege to create new storage groups.

CREATETMTAB

Revokes the privilege to use the CREATE GLOBAL TEMPORARY TABLE statement.

CREATE_SECURE_OBJECT

Revokes the privilege to create a secure object.

DATAACCESS

Revokes the DATAACCESS authority, but does not revoke any privileges that are dependent on it. Revoking DATAACCESS can result in authorization cache entries (plan, package, routine, and dynamic statement) being updated if they were dependent on it. The RESTRICT semantics on objects prevents the DATAACCESS authority from being revoked if the revokee owns an object that was created with dependencies on the authority to be revoked.

Revoking DATAACCESS is similar to revoking the individual privileges that DATAACCESS includes. For example, if a view was created based on the view owner having the SELECT privilege as acquired through the DATAACCESS authority, revoking DATAACCESS would be the equivalent of revoking the SELECT privilege and the view would be dropped.

DBADM

Revokes the DBADM authority from the user. If this user was also granted DATAACCESS or ACCESSCTRL authority along with DBADM authority, DATAACCESS or ACCESSCTRL would not be revoked.

DISPLAY

Revokes the privilege to use the following commands:

- The DISPLAY ARCHIVE command for archive log information

- The DISPLAY BUFFERPOOL command for the status of buffer pools
- The DISPLAY DATABASE command for the status of all databases
- The DISPLAY FUNCTION SPECIFIC command for statistics about accessed external user-defined functions
- The DISPLAY LOCATION command for statistics about threads with a distributed relationship
- The DISPLAY PROCEDURE command for statistics about accessed stored procedures
- The DISPLAY THREAD command for information on active threads with in Db2
- The DISPLAY TRACE command for a list of active traces

DEBUGSESSION

Revokes the privilege to create a debug session, which prevents client application debugging of native SQL or Java procedures that are executed within the session.

EXPLAIN

Revokes the privilege to issue the following:

- The EXPLAIN statement with the following options:
 - PLAN
 - ALL
- The PREPARE statement
- The DESCRIBE TABLE statement
- The ability to explain dynamic SQL statements that are executing with the special register CURRENT EXPLAIN MODE = EXPLAIN
- The BIND options EXPLAIN(ONLY) and SQLERROR(CHECK)

EXPLAIN(ONLY) allows to explain the statements. SQLERROR(CHECK) performs all syntax and semantic checks on the SQL statements being bound.

MONITOR1

Revokes the privilege to obtain IFC data classified as serviceability data, statistics, accounting, and other performance data that does not contain potentially secure data.

MONITOR2

Revokes the privilege to obtain IFC data classified as containing potentially sensitive data such as SQL statement text and audit data. (Having the MONITOR2 privilege also implies having MONITOR1 privileges, however, revoking the MONITOR2 privilege does not cause the revoke of an explicitly granted MONITOR1 privilege.)

RECOVER

Revokes the privilege to issue the RECOVER INDOUBT command.

SQLADM

Revokes the privilege to issue the following:

- The DESCRIBE TABLE statement
- The EXPLAIN statement with the following options:
 - PLAN
 - ALL
 - STMTCACHE ALL
 - STMTID
 - STMTTOKEN
 - MONITORED STMTS
- The PREPARE statement
- The ability to explain dynamic SQL statements that are executing with the special register CURRENT EXPLAIN MODE = EXPLAIN

- The BIND options EXPLAIN(ONLY) and SQLERROR(CHECK)
EXPLAIN(ONLY) allows to explain the statements. SQLERROR(CHECK) performs all syntax and semantic checks on the SQL statements being bound.
- The START command
- The STOP command
- The DISPLAY PROFILE command
- The ability to execute the RUNSTATS utility and the MODIFY STATISTICS utility in any database
- MONITOR2 privilege, which allows users to obtain IFC data that is classified as containing potentially sensitive data, such as SQL statement text and audit data, as well as IFC data that is classified as serviceability data, statistics, accounting, and other performance data.

STOPALL

Revokes the privilege to use the STOP DB2 command.

STOSPACE

Revokes the privilege to use the STOSPACE utility.

SYSADM

Revokes the system administrator authority.

SYSCTRL

Revokes the system control authority.

SYSOPR

Revokes the system operator authority.

TRACE

Revokes the privilege to use the MODIFY TRACE, START TRACE, and STOP TRACE commands.

ON SYSTEM

Identifies that the system privilege is revoked for the entire Db2 subsystem.

FROM

Refer to [“REVOKE statement” on page 2070](#) for a description of the FROM clause.

BY

Refer to [“REVOKE statement” on page 2070](#) for a description of the BY clause.

INCLUDING DEPENDENT PRIVILEGES or NOT INCLUDING DEPENDENT PRIVILEGES

Specifies whether revoking a privilege or an authority from an authorization ID or a role also results in revoking the grants that were made by that user. The default value is based on the authority that is being revoked and the REVOKE_DEP_PRIVILEGES system parameter:

- When ACCESSCTRL, DATAACCESS, or system DBADM authority is revoked, NOT INCLUDING DEPENDENT PRIVILEGES is assumed and the clause must be specified on the REVOKE statement.
- When the REVOKE_DEP_PRIVILEGES system parameter is set to NO, NOT INCLUDING DEPENDENT PRIVILEGES is assumed and an error is returned if the statement includes INCLUDING DEPENDENT PRIVILEGES.
- Otherwise, INCLUDING DEPENDENT PRIVILEGES is assumed and the clause must be specified on the REVOKE statement.

INCLUDING DEPENDENT PRIVILEGES

Specifies that revoking a privilege or an authority from an authorization ID or a role also results in revoking dependent privileges. This means that any grants that were made by the user will continue to be revoked, until all grants in the chain have been revoked.

INCLUDING DEPENDENT PRIVILEGES cannot be specified if the system parameter REVOKE_DEP_PRIVILEGES is set to NO, which enforces the behavior to not include the dependent privileges.

NOT INCLUDING DEPENDENT PRIVILEGES

Specifies that revoking a privilege or an authority from an authorization ID or a role does not cause the grants that were made by the user to be revoked. However, for the revoked privileges, all

implications of the privilege being revoked are applied. For example, if the revoked privileges were required to bind a package successfully, that package would continue to be invalidated as a result of the package owner losing these privileges. An object might be dropped if a privilege is revoked that was used to create the object.

NOT INCLUDING DEPENDENT PRIVILEGES must be specified when ACCESSCTRL, DATAACCESS, or system DBADM authority is revoked.

NOT INCLUDING DEPENDENT PRIVILEGES cannot be specified if the system parameter REVOKE_DEP_PRIVILEGES is set to YES, which enforces the behavior to include dependent privileges in the revoke.

Examples for REVOKE (system privileges)

Example 1: Revoke DISPLAY privileges from user LUTZ.

```
REVOKE DISPLAY
FROM LUTZ;
```

Example 2: Revoke BSDS and RECOVER privileges from users PARKER and SETRIGHT.

```
REVOKE BSDS, RECOVER
FROM PARKER, SETRIGHT;
```

Example 3: Revoke TRACE privileges previously granted to all local users. (Grants to specific users will not be affected.)

```
REVOKE TRACE
FROM PUBLIC;
```

Example 4: Revoke ARCHIVE privileges from role ROLE1:

```
REVOKE ARCHIVE
FROM ROLE ROLE1;
```

Example 5: SECADM Mary revokes the privilege to create a secure object from Steve that was granted by another SECADM.

```
REVOKE CREATE_SECURE_OBJECT
FROM STEVE BY MARY;
```

Example 6: Revoke system DBADM from the role, ADMINROLE. This only revokes system DBADM authority from the role. If DATAACCESS and ACCESSCTRL authorities were granted during GRANT DBADM, those authorities are not revoked.

```
REVOKE DBADM ON SYSTEM
FROM ROLE ADMINROLE
NOT INCLUDING DEPENDENT PRIVILEGES;
```

Example 7: Revoke system DBADM, DATAACCESS, and ACCESSCTRL authorities from the role, ADMINROLE.

```
REVOKE DBADM, DATAACCESS, ACCESSCTRL ON SYSTEM
FROM ROLE ADMINROLE
NOT INCLUDING DEPENDENT PRIVILEGES;
```

REVOKE statement (table or view privileges)

This form of the REVOKE statement revokes privileges on one or more tables or views.

Syntax for REVOKE (table or view privileges)

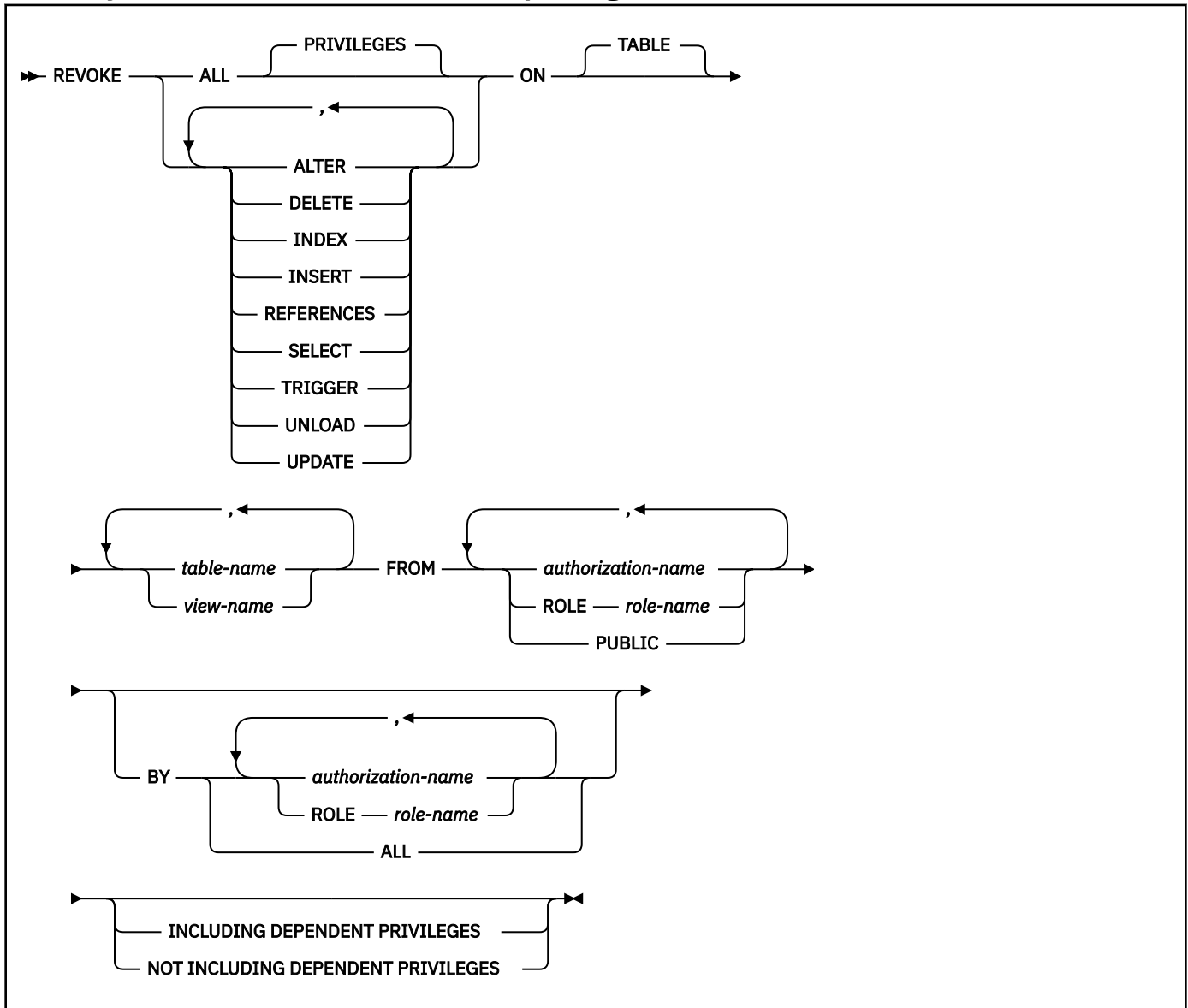

Description for REVOKE (table or view privileges)

ALL or ALL PRIVILEGES

If you specify ALL, the authorization ID of the statement must have granted a least one privilege on each identified table or view to each *authorization-name*. The privilege revoked from an authorization ID are those privileges on the table or view that the authorization ID of the statement granted to the authorization ID.

If you do not use ALL, you must use one or more of the keywords listed below. Each keyword revokes the privilege described, but only as it applies to the tables or views named in the ON clause.

ALTER

Revokes the privilege to alter the specified table or create a trigger on the specified table.

DELETE

Revokes the privilege to delete rows in the specified table or view.

INDEX

Revokes the privilege to create an index on the specified table.

INSERT

Revokes the privilege to insert rows into the specified table or view.

REFERENCES

Revokes the privilege to define and drop referential constraints. Although you can use a list of column names with the GRANT statement, you cannot use a list of column names with REVOKE; the privilege is revoked for all columns.

SELECT

Revokes the privilege to create a view or read data from the specified table or view. A view or a materialized query table is dropped when the SELECT privilege that was used to create it is revoked, unless the owner of the view or materialized query table was directly granted the SELECT privilege from another source before the view or materialized query table was created.

TRIGGER

Revokes the privilege to create a trigger on the specified table.

UNLOAD

Revokes the UNLOAD privilege to use the UNLOAD utility.

UPDATE

Revokes the privilege to update rows in the specified table or view. A list of column names can be used only with GRANT, not with REVOKE.

ON *table-name or view-name*

Names one or more tables or views on which you are revoking the privileges. The list can consist of table names, view names, or a combination of the two. A table or view must not be identified more than one time, and a declared temporary table and a table that is implicitly created for an XML column must not be identified.

FROM

Refer to [“REVOKE statement” on page 2070](#) for a description of the FROM clause.

BY

If you omit BY, you must have granted each named privilege to each of the named users. More precisely, each privilege must have been granted to each user by a GRANT statement whose authorization ID is also the authorization ID of your REVOKE statement. Each of these grants is then revoked. (No single privilege need be granted on all tables and views.)

If BY is specified, each named grantor must satisfy the above requirement. In that case, the authorization ID of the statement need not satisfy the requirement unless it is one of the named grantors.

Refer to [“REVOKE statement” on page 2070](#) for a description of the BY clause.

INCLUDING DEPENDENT PRIVILEGES or NOT INCLUDING DEPENDENT PRIVILEGES

Specifies whether revoking a privilege or an authority from an authorization ID or a role also results in revoking the grants that were made by that user. The default value is based on the authority that is being revoked and the REVOKE_DEP_PRIVILEGES system parameter:

- When ACCESSCTRL, DATAACCESS, or system DBADM authority is revoked, NOT INCLUDING DEPENDENT PRIVILEGES is assumed and the clause must be specified on the REVOKE statement.
- When the REVOKE_DEP_PRIVILEGES system parameter is set to NO, NOT INCLUDING DEPENDENT PRIVILEGES is assumed and an error is returned if the statement includes INCLUDING DEPENDENT PRIVILEGES.
- Otherwise, INCLUDING DEPENDENT PRIVILEGES is assumed and the clause must be specified on the REVOKE statement.

INCLUDING DEPENDENT PRIVILEGES

Specifies that revoking a privilege or an authority from an authorization ID or a role also results in revoking dependent privileges. This means that any grants that were made by the user will continue to be revoked, until all grants in the chain have been revoked.

INCLUDING DEPENDENT PRIVILEGES cannot be specified if the system parameter REVOKE_DEP_PRIVILEGES is set to NO, which enforces the behavior to not include the dependent privileges.

NOT INCLUDING DEPENDENT PRIVILEGES

Specifies that revoking a privilege or an authority from an authorization ID or a role does not cause the grants that were made by the user to be revoked. However, for the revoked privileges, all implications of the privilege being revoked are applied. For example, if the revoked privileges were required to bind a package successfully, that package would continue to be invalidated as a result of the package owner losing these privileges. An object might be dropped if a privilege is revoked that was used to create the object.

NOT INCLUDING DEPENDENT PRIVILEGES must be specified when ACCESSCTRL, DATAACCESS, or system DBADM authority is revoked.

NOT INCLUDING DEPENDENT PRIVILEGES cannot be specified if the system parameter REVOKE_DEP_PRIVILEGES is set to YES, which enforces the behavior to include dependent privileges in the revoke.

Notes for REVOKE (table or view privileges)

For a created temporary table, only ALL or ALL PRIVILEGES can be revoked. Specific table privileges cannot be revoked.

For a view of a created temporary table, either ALL or the specific UPDATE, DELETE, INSERT and SELECT privileges can be revoked.

For a declared temporary table, no privileges can be revoked because none can be granted. When a declared temporary table is defined, PUBLIC implicitly receives all table privileges (without GRANT authority) for the table. These privileges are not recorded in the Db2 catalog.

Examples for REVOKE (table or view privileges)

Example 1: Revoke SELECT privileges on table DSN8C10.EMP from user PULASKI.

```
REVOKE SELECT ON TABLE DSN8C10.EMP FROM PULASKI;
```

Example 2: Revoke update privileges on table DSN8C10.EMP previously granted to all local Db2 users. (Grants to specific users are not affected.)

```
REVOKE UPDATE ON TABLE DSN8C10.EMP FROM PUBLIC;
```

Example 3: Revoke all privileges on table DSN8C10.EMP from users KWAN and THOMPSON.

```
REVOKE ALL ON TABLE DSN8C10.EMP FROM KWAN,THOMPSON;
```

Example 4: Revoke the grant of SELECT and UPDATE privileges on the table DSN8C10.DEPT to every user in the network. Doing so does not affect users who obtained these privileges from some other grant.

```
REVOKE SELECT, UPDATE ON TABLE DSN8C10.DEPT  
FROM PUBLIC;
```

Example 5: Revoke the ALTER privileges on the table DSN8C10.EMP that were previously granted to role ROLE1:

```
REVOKE ALTER ON TABLE DSN8C10.EMP  
FROM ROLE ROLE1;
```

REVOKE (type or JAR file privileges)

This form of the REVOKE statement revokes the privilege to use distinct types, array types, or JAR files.

Syntax for REVOKE (type or JAR file privileges)

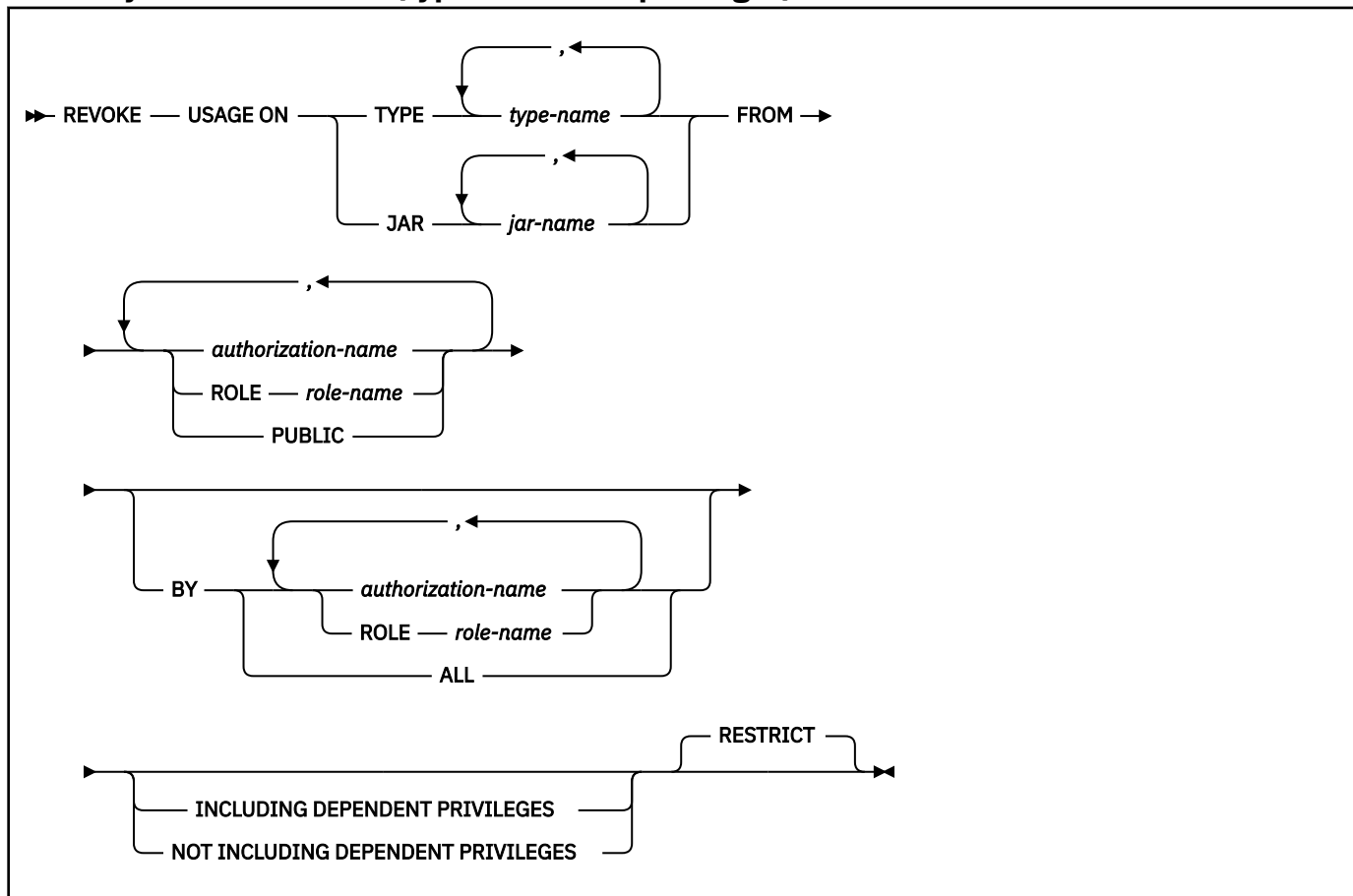

Description for REVOKE (type or JAR file privileges)

USAGE

Revokes the privilege to use the distinct type in tables, functions procedures, or the privilege to use the JAR file.

TYPE *type-name*

Identifies the user-defined type. The name, including the implicit or explicit schema name, must identify a unique user-defined type that exists at the current server.

JAR *jar-name*

Identifies the JAR file. The name, including the implicit or explicit schema name, must identify a unique JAR file that exists at the current server.

FROM

Refer to [“REVOKE statement” on page 2070](#) for a description of the FROM clause.

BY

Refer to [“REVOKE statement” on page 2070](#) for a description of the BY clause.

INCLUDING DEPENDENT PRIVILEGES or NOT INCLUDING DEPENDENT PRIVILEGES

Specifies whether revoking a privilege or an authority from an authorization ID or a role also results in revoking the grants that were made by that user. The default value is based on the authority that is being revoked and the REVOKE_DEP_PRIVILEGES system parameter:

- When ACCESSCTRL, DATAACCESS, or system DBADM authority is revoked, NOT INCLUDING DEPENDENT PRIVILEGES is assumed and the clause must be specified on the REVOKE statement.
- When the REVOKE_DEP_PRIVILEGES system parameter is set to NO, NOT INCLUDING DEPENDENT PRIVILEGES is assumed and an error is returned if the statement includes INCLUDING DEPENDENT PRIVILEGES.
- Otherwise, INCLUDING DEPENDENT PRIVILEGES is assumed and the clause must be specified on the REVOKE statement.

INCLUDING DEPENDENT PRIVILEGES

Specifies that revoking a privilege or an authority from an authorization ID or a role also results in revoking dependent privileges. This means that any grants that were made by the user will continue to be revoked, until all grants in the chain have been revoked.

INCLUDING DEPENDENT PRIVILEGES cannot be specified if the system parameter REVOKE_DEP_PRIVILEGES is set to NO, which enforces the behavior to not include the dependent privileges.

NOT INCLUDING DEPENDENT PRIVILEGES

Specifies that revoking a privilege or an authority from an authorization ID or a role does not cause the grants that were made by the user to be revoked. However, for the revoked privileges, all implications of the privilege being revoked are applied. For example, if the revoked privileges were required to bind a package successfully, that package would continue to be invalidated as a result of the package owner losing these privileges. An object might be dropped if a privilege is revoked that was used to create the object.

NOT INCLUDING DEPENDENT PRIVILEGES must be specified when ACCESSCTRL, DATAACCESS, or system DBADM authority is revoked.

NOT INCLUDING DEPENDENT PRIVILEGES cannot be specified if the system parameter REVOKE_DEP_PRIVILEGES is set to YES, which enforces the behavior to include dependent privileges in the revoke.

RESTRICT

Prevents the USAGE privilege from being revoked on a user-defined type or JAR file if any of the following conditions exist and the revokee does not have the USAGE privilege from another source:

- The revokee owns a function or stored procedure that uses the user-defined type or references the JAR file.
- The revokee owns a JAR file whose path references the JAR file for which USAGE is being revoked.
- The revokee owns a table that has a column that uses the user-defined type.
- A sequence exists for which the data type of the sequence is the user-defined type.

Notes for REVOKE (type or JAR file privileges)

Alternative syntax and synonyms: To provide compatibility with previous releases of Db2 or other products in the Db2 family, Db2 supports DATA TYPE or DISTINCT TYPE as a synonym for TYPE.

Examples for REVOKE (type or JAR file privileges)

Example 1: Revoke the USAGE privilege on distinct type SHOESIZE from user JONES.

```
REVOKE USAGE ON TYPE SHOESIZE FROM JONES;
```

Example 2: Revoke the USAGE privilege on distinct type US_DOLLAR from all users at the current server except for those who have been specifically granted USAGE and not through PUBLIC.

```
REVOKE USAGE ON TYPE US_DOLLAR FROM PUBLIC;
```

Example 3: Revoke the USAGE privilege on distinct type CANADIAN_DOLLARS from the administrative assistant (ADMIN_A).

```
REVOKE USAGE ON TYPE CANADIAN_DOLLARS
FROM ADMIN_A;
```

Example 4: Revoke the USAGE privilege on distinct type MILES from the role ROLE1:

```
REVOKE USAGE ON TYPE MILES
FROM ROLE ROLE1;
```

REVOKE (variable privileges)

This form of the REVOKE statement revokes privileges on global variables.

Syntax for REVOKE (variable privileges)

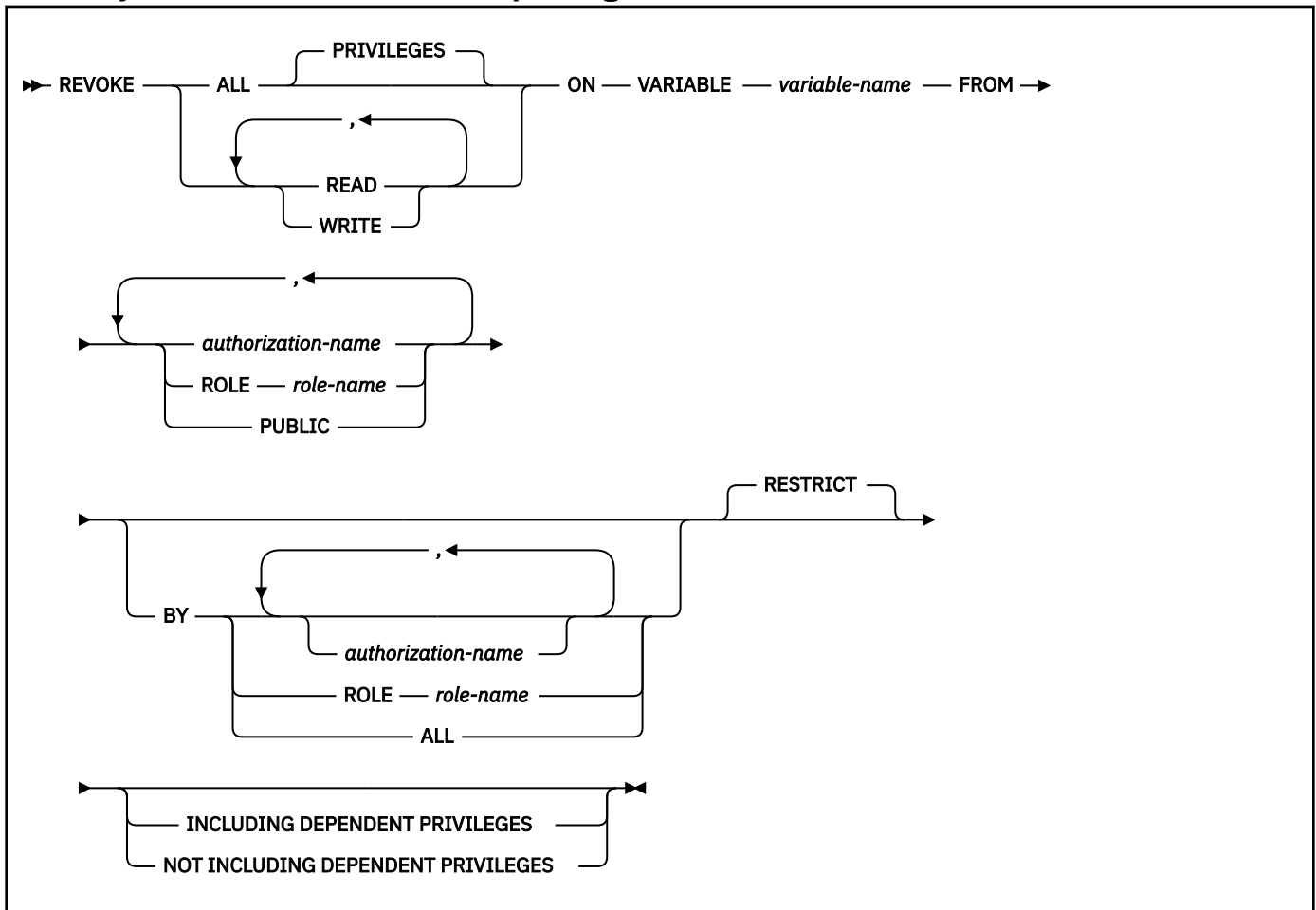

Description for REVOKE (variable privileges)

ALL PRIVILEGES

Revokes both READ and WRITE privileges on the specified global variable.

READ

Revokes the privilege to read the value of the specified global variable.

WRITE

Revokes the privilege to assign a value to the specified global variable.

ON VARIABLE *variable-name*

Identifies the global variable from which privileges are revoked. *variable-name* must identify a global variable that exists at the current server.

FROM

Refer to [“REVOKE statement” on page 2070](#) for a description of the FROM clause.

BY

Refer to [“REVOKE statement” on page 2070](#) for a description of the BY clause.

RESTRICT

Prevents the specified privileges from being revoked on a global variable if the following conditions exist:

- A function that is owned by the revokee references (READ or WRITE privilege) the specified global variable
- A view that is owned by the revokee references (READ or WRITE privilege) the specified global variable
- A trigger that is owned by the revokee references (READ or WRITE privilege) the specified global variable

INCLUDING DEPENDENT PRIVILEGES or NOT INCLUDING DEPENDENT PRIVILEGES

Specifies whether revoking a privilege or an authority from an authorization ID or a role also results in revoking the grants that were made by that user. The default value is based on the authority that is being revoked and the REVOKE_DEP_PRIVILEGES system parameter:

- When ACCESSCTRL, DATAACCESS, or system DBADM authority is revoked, NOT INCLUDING DEPENDENT PRIVILEGES is assumed and the clause must be specified on the REVOKE statement.
- When the REVOKE_DEP_PRIVILEGES system parameter is set to NO, NOT INCLUDING DEPENDENT PRIVILEGES is assumed and an error is returned if the statement includes INCLUDING DEPENDENT PRIVILEGES.
- Otherwise, INCLUDING DEPENDENT PRIVILEGES is assumed and the clause must be specified on the REVOKE statement.

INCLUDING DEPENDENT PRIVILEGES

Specifies that revoking a privilege or an authority from an authorization ID or a role also results in revoking dependent privileges. This means that any grants that were made by the user will continue to be revoked, until all grants in the chain have been revoked.

INCLUDING DEPENDENT PRIVILEGES cannot be specified if the system parameter REVOKE_DEP_PRIVILEGES is set to NO, which enforces the behavior to not include the dependent privileges.

NOT INCLUDING DEPENDENT PRIVILEGES

Specifies that revoking a privilege or an authority from an authorization ID or a role does not cause the grants that were made by the user to be revoked. However, for the revoked privileges, all implications of the privilege being revoked are applied. For example, if the revoked privileges were required to bind a package successfully, that package would continue to be invalidated as a result of the package owner losing these privileges. An object might be dropped if a privilege is revoked that was used to create the object.

NOT INCLUDING DEPENDENT PRIVILEGES must be specified when ACCESSCTRL, DATAACCESS, or system DBADM authority is revoked.

NOT INCLUDING DEPENDENT PRIVILEGES cannot be specified if the system parameter REVOKE_DEP_PRIVILEGES is set to YES, which enforces the behavior to include dependent privileges in the revoke.

Notes for REVOKE (variable privileges)

Global variables and statements in the dynamic statement cache: If a cached dynamic statement depends on the revoked authorization for the specified global variable and the cache statement is not in use, the cached dynamic statement will be invalidated.

REVOKE statement (use privileges)

This form of the REVOKE statement revokes authority to use particular buffer pools, storage groups, or table spaces.

Syntax for REVOKE (use privileges)

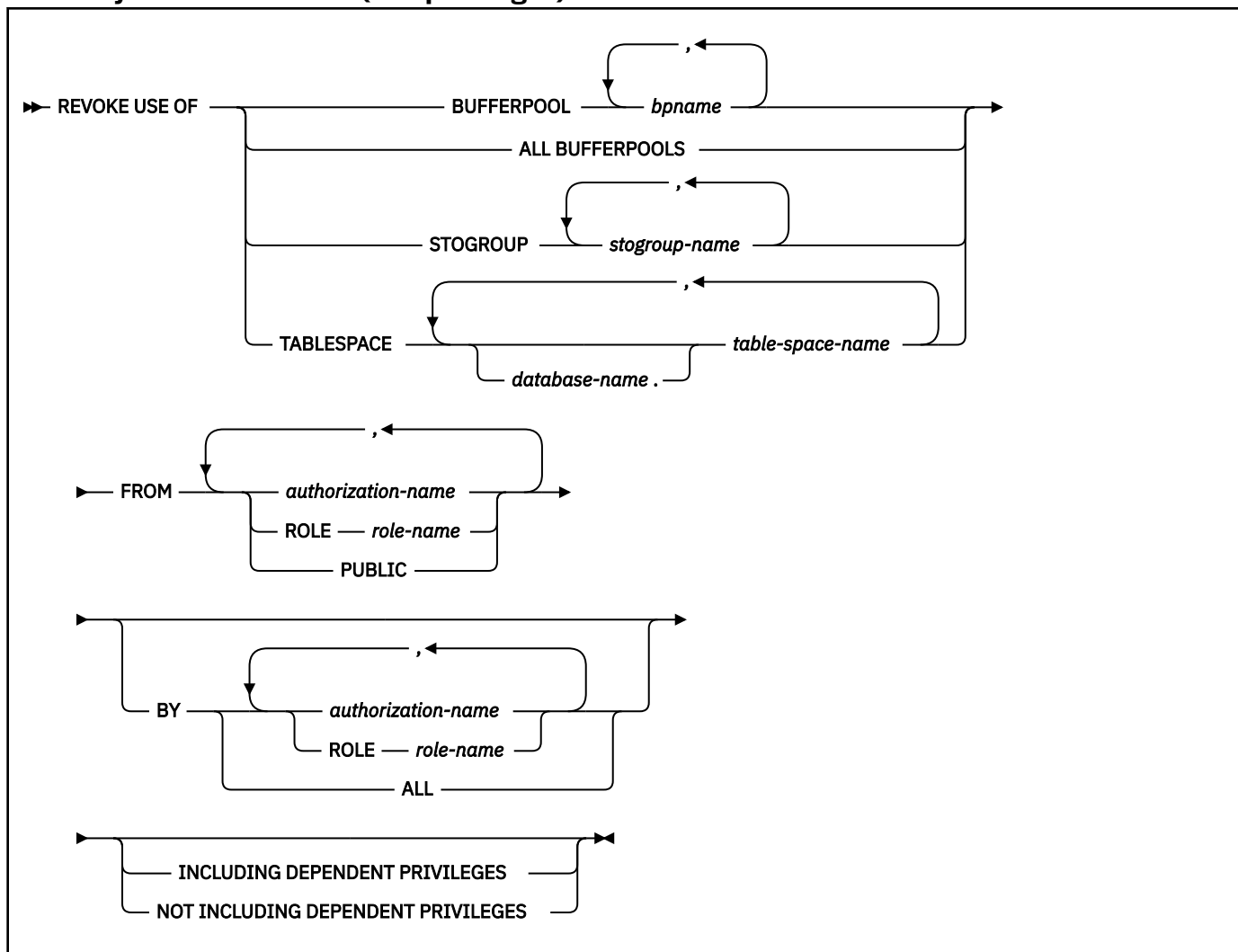

Description for REVOKE (use privileges)

BUFFERPOOL *bpname*,...

Revokes the privilege to refer to any of the identified buffer pools in a CREATE INDEX, CREATE TABLESPACE, ALTER INDEX, or ALTER TABLESPACE statement. See [“Naming conventions in SQL” on page 79](#) for more details about *bpname*.

ALL BUFFERPOOLS

Revokes the privilege to refer to any buffer pool in a CREATE INDEX, CREATE TABLESPACE, ALTER INDEX, or ALTER TABLESPACE statement.

STOGROUP *stogroup-name*,...

Revokes the privilege to refer to any of the identified storage groups in a CREATE INDEX, CREATE TABLESPACE, ALTER INDEX, or ALTER TABLESPACE statement.

TABLESPACE *database-name.table-space-name*,...

Revokes the privilege to refer to any of the specified table spaces in a CREATE TABLE statement. The default *database-name* is DSNDB04.

For table spaces in a work file database you cannot revoke the privilege from PUBLIC. When a table space is created in a work file database, PUBLIC implicitly receives the TABLESPACE privilege (without GRANT authority); this privilege is not recorded in the Db2 catalog, and it cannot be revoked.

FROM

Refer to [“REVOKE statement” on page 2070](#) for a description of the FROM clause.

BY

Refer to [“REVOKE statement” on page 2070](#) for a description of the BY clause.

INCLUDING DEPENDENT PRIVILEGES or NOT INCLUDING DEPENDENT PRIVILEGES

Specifies whether revoking a privilege or an authority from an authorization ID or a role also results in revoking the grants that were made by that user. The default value is based on the authority that is being revoked and the REVOKE_DEP_PRIVILEGES system parameter:

- When ACCESSCTRL, DATAACCESS, or system DBADM authority is revoked, NOT INCLUDING DEPENDENT PRIVILEGES is assumed and the clause must be specified on the REVOKE statement.
- When the REVOKE_DEP_PRIVILEGES system parameter is set to NO, NOT INCLUDING DEPENDENT PRIVILEGES is assumed and an error is returned if the statement includes INCLUDING DEPENDENT PRIVILEGES.
- Otherwise, INCLUDING DEPENDENT PRIVILEGES is assumed and the clause must be specified on the REVOKE statement.

INCLUDING DEPENDENT PRIVILEGES

Specifies that revoking a privilege or an authority from an authorization ID or a role also results in revoking dependent privileges. This means that any grants that were made by the user will continue to be revoked, until all grants in the chain have been revoked.

INCLUDING DEPENDENT PRIVILEGES cannot be specified if the system parameter REVOKE_DEP_PRIVILEGES is set to NO, which enforces the behavior to not include the dependent privileges.

NOT INCLUDING DEPENDENT PRIVILEGES

Specifies that revoking a privilege or an authority from an authorization ID or a role does not cause the grants that were made by the user to be revoked. However, for the revoked privileges, all implications of the privilege being revoked are applied. For example, if the revoked privileges were required to bind a package successfully, that package would continue to be invalidated as a result of the package owner losing these privileges. An object might be dropped if a privilege is revoked that was used to create the object.

NOT INCLUDING DEPENDENT PRIVILEGES must be specified when ACCESSCTRL, DATAACCESS, or system DBADM authority is revoked.

NOT INCLUDING DEPENDENT PRIVILEGES cannot be specified if the system parameter REVOKE_DEP_PRIVILEGES is set to YES, which enforces the behavior to include dependent privileges in the revoke.

Notes for REVOKE (use privileges)

You can revoke privileges for only one type of object with each statement. Thus you can revoke the use of several table spaces with one statement, but not the use of a table space and a storage group.

For each object you name, you (or the indicated grantors) must have granted the USE privilege on that object to all identified users (including PUBLIC, if specified). The same object must not be identified more than once.

Revoking the privilege USE OF ALL BUFFERPOOLS does not cascade to all other privileges that can be granted under that privilege. A user with the privilege USE OF ALL BUFFERPOOLS WITH GRANT OPTION can make two types of grants:

- GRANT USE OF ALL BUFFERPOOLS TO *userid*. This privilege is revoked when the original user's privilege is revoked.
- GRANT USE OF BUFFERPOOL BPn TO *userid*. This privilege is *not revoked* when the original user's privilege is revoked.

Examples for REVOKE (use privileges)

Example 1: Revoke authority to use buffer pool BP2 from user MARINO.

```
REVOKE USE OF BUFFERPOOL BP2
FROM MARINO;
```

Example 2: Revoke a grant of the USE privilege on the table space DSN8S12D in the database DSN8D12A. The grant is to PUBLIC, that is, to everyone at the local Db2 subsystem. (Grants to specific users are not affected.)

```
REVOKE USE OF TABLESPACE DSN8D12A.DSN8S12D
FROM PUBLIC;
```

Example 3: Revoke the authority to use storage group SG1 from role ROLE1:

```
REVOKE USE OF STOGROUP SG1
FROM ROLE ROLE1;
```

ROLLBACK statement

The ROLLBACK statement can be used to end a unit of recovery and back out all the relational database changes that were made by that unit of recovery. If relational databases are the only recoverable resources used by the application process, ROLLBACK also ends the unit of work. ROLLBACK can also be used to back out only the changes made after a savepoint was set within the unit of recovery without ending the unit of recovery. Rolling back to a savepoint enables selected changes to be undone.

Invocation for ROLLBACK

This statement can be embedded in an application program or issued interactively. It is an executable statement that can be dynamically prepared. It can be used in the IMS or CICS environment only if the TO SAVEPOINT clause is specified.

Authorization for ROLLBACK

None required.

Syntax for ROLLBACK

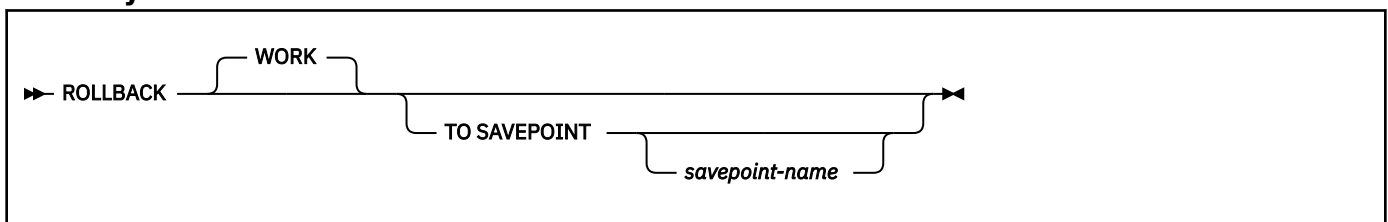

Description for ROLLBACK

When ROLLBACK is used without the SAVEPOINT clause, the unit of recovery in which the ROLLBACK statement is executed is ended and a new unit of recovery is started.

All changes that are made by the following statements during the unit of recovery are backed out:

- ALTER
- COMMENT
- CREATE
- DELETE
- DROP
- EXPLAIN
- GRANT
- INSERT
- LABEL
- MERGE
- REFRESH TABLE
- RENAME
- REVOKE
- SELECT INTO with an SQL data change statement
- select-statement with an SQL data change statement
- TRUNCATE when the IMMEDIATE clause is not specified
- UPDATE

ROLLBACK without the TO SAVEPOINT clause also causes the following actions to occur:

- All locks that are implicitly acquired during the unit of recovery are released. See [“LOCK TABLE statement” on page 2017](#) for an explanation of the duration of explicitly acquired locks.
- All cursors are closed, all prepared statements are destroyed, and any cursors that are associated with the prepared statements are invalidated.
- All rows and all logical work files of every created temporary table of the application process are deleted. (All the rows of a declared temporary table are not implicitly deleted. As with base tables, any changes that are made to a declared temporary table during the unit of recovery are undone to restore the table to its state at the last commit point.)
- All LOB locators, including those that are held, are freed.

TO SAVEPOINT

Specifies that the unit of recovery is not to be ended and that only a partial rollback (to a savepoint) is to be performed. If a savepoint name is not specified, rollback is to the last active savepoint. For example, if in a unit of recovery, savepoints A, B, and C are set in that order and then C is released, ROLLBACK TO SAVEPOINT causes a rollback to savepoint B.

savepoint-name

Identifies the savepoint to which to roll back. The name must identify a savepoint that exists at the current server.

All database changes (including changes made to a declared temporary tables but excluding changes made to created temporary tables) that were made after the savepoint was set are backed out. Changes that are made to created temporary tables are not logged and are not backed out; a warning is issued instead. (A warning is also issued when a created temporary table is changed and there is an active savepoint.)

In addition, none of the following items are backed out:

- The opening or closing of cursors
- Changes in cursor positioning
- The acquisition and release of locks
- The caching of the rolled back statements

Any savepoints that are set after the one to which rollback is performed are released. The savepoint to which rollback is performed is not released.

ROLLBACK with or without the TO SAVEPOINT clause has no effect on connections.

Notes for ROLLBACK

The following information applies only to rolling back all changes in the unit of recovery (the ROLLBACK statement without the TO SAVEPOINT clause):

- *Stored procedures.* The ROLLBACK statement cannot be used if the procedure is in the calling chain of a user-defined function or a trigger or if Db2 is not the commit coordinator.
- *IMS or CICS.* Using a ROLLBACK TO SAVEPOINT statement in an IMS or CICS environment only rolls back Db2 resources. Any other recoverable resources updated in the environment are not rolled back. To do a rollback operation in these environments, SQL programs must use the call prescribed by their transaction manager. The effect of these rollback operations on Db2 data is the same as that of the SQL ROLLBACK statement.

A rollback operation in an IMS or CICS environment might handle the closing of cursors that were declared with the WITH hold option differently than the SQL ROLLBACK statement does. If an application requests a rollback operation from CICS or IMS, but no work has been performed in Db2 since the last commit point, the rollback request will not be broadcast to Db2. If the application had opened cursors using the WITH HOLD option in a previous unit of work, the cursors will not be closed, and any prepared statements associated with those cursors will not be destroyed.

- *Implicit rollback operations:* In all Db2 environments, the abend of a process is an implicit rollback operation.

ROLLBACK and non-LOB table spaces that are not logged: If ROLLBACK is executed for a unit of work that includes changes to a non-LOB table space that is not logged (specifies the NOT LOGGED attribute), that table space is marked RECOVER-pending and the table space is placed in the logical page list. The table space is therefore not available after the rollback operation completes. For more information about the RECOVER utility, see [RECOVER \(Db2 Utilities\)](#).

ROLLBACK and declared global temporary tables that are not logged: When NOT LOGGED is specified on a declared global temporary table and Db2 must roll back because of an error such as a duplicate key error, rows are deleted or preserved depending on the option that was specified for ON ROLLBACK.

If the ON ROLLBACK DELETE ROWS option was specified for the table, insert, update, and delete activity is not logged. During a ROLLBACK or ROLLBACK TO SAVEPOINT operation, if the table was updated since the last COMMIT statement, all rows are deleted from the table. Any open cursors for the table do not have positions. If the declaration of the declared global temporary table was not committed, the declaration of the table is rolled back.

If the ON ROLLBACK PRESERVE ROWS option was specified for the table, insert, update, and delete activity is not logged. During a ROLLBACK or ROLLBACK TO SAVEPOINT operation, all rows in the table are preserved regardless of any updates to the table since the last COMMIT statement. Any open cursors for the table do not have positions. If the declaration of the declared global temporary table was not committed, the declaration of the table is rolled back.

Effect of ROLLBACK on global variables: Global variables are not controlled at the transaction level. Issuing a ROLLBACK statement does not affect the contents of a global variable.

Effect of ROLLBACK on insert operations: If execution of an INSERT statement results in creation of a data set in a table space, and the INSERT operation is rolled back, the inserted data is deleted, but the data set is not deleted.

Effect of ROLLBACK on prepared dynamic statements: All prepared dynamic statements in a package that is bound with KEEP DYNAMIC(YES) are kept past rollback points.

Examples for ROLLBACK

Example 1: Roll back all Db2 database changes made since the unit of recovery was started.

```
ROLLBACK WORK;
```

Example 2: After a unit of recovery started, assume that three savepoints A, B, and C were set and that C was released:

```
...  
SAVEPOINT A ON ROLLBACK RETAIN CURSORS;  
...  
SAVEPOINT B ON ROLLBACK RETAIN CURSORS;  
...  
SAVEPOINT C ON ROLLBACK RETAIN CURSORS;  
...  
RELEASE SAVEPOINT C;  
...
```

Roll back all Db2 database changes only to savepoint A:

```
ROLLBACK WORK TO SAVEPOINT A;
```

If a savepoint name was not specified (that is, `ROLLBACK WORK TO SAVEPOINT`), the rollback would be to the last active savepoint that was set, which is B.

SAVEPOINT statement

The `SAVEPOINT` statement sets a savepoint within a unit of recovery to identify a point in time within the unit of recovery to which relational database changes can be rolled back.

Invocation for `SAVEPOINT`

This statement can be imbedded in an application program or issued interactively. It is an executable statement that can be dynamically prepared.

Authorization for `SAVEPOINT`

None required.

Syntax for `SAVEPOINT`

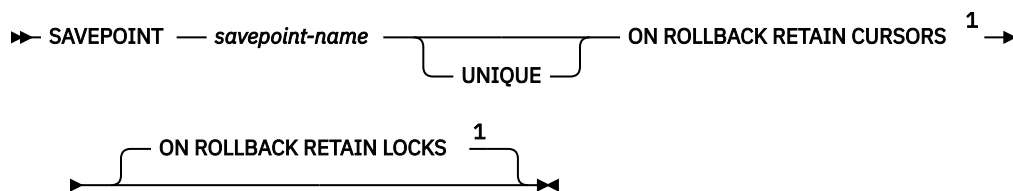

Notes:

¹ These clauses can be specified in either order.

Description for `SAVEPOINT`

savepoint-name

Names the savepoint. *savepoint-name* must not begin with 'SYS'.

UNIQUE

Specifies that the application program cannot reuse the savepoint name within the unit of recovery. An error occurs if a savepoint with the same name as *savepoint-name* already exists within the unit of recovery.

Omitting UNIQUE indicates that the application can reuse the savepoint name within the unit of recovery. If *svpt-name* identifies a savepoint that already exists within the unit of recovery and the savepoint was not created with the UNIQUE option, the existing savepoint is destroyed and a new savepoint is created. Destroying a savepoint to reuse its name for another savepoint is not the same as releasing the savepoint. Reusing a savepoint name destroys only one savepoint. Releasing a savepoint with the RELEASE SAVEPOINT statement releases the savepoint and all savepoints that have been subsequently set.

ON ROLLBACK RETAIN CURSORS

Specifies that any cursors that are opened after the savepoint is set are not tracked, and thus, are not closed upon rollback to the savepoint. Although these cursors remain open after rollback to the savepoint, they might not be usable. For example, if rolling back to the savepoint causes the insertion of a row on which the cursor is positioned to be rolled back, using the cursor to update or delete the row results in an error.

ON ROLLBACK RETAIN LOCKS

Specifies that any locks that are acquired after the savepoint is set are not tracked, and thus, are not released on rollback to the savepoint. ON ROLLBACK RETAIN LOCKS is the default behavior.

Example for SAVEPOINT

Assume that you want to set three savepoints at various points in a unit of recovery. Name the first savepoint A and allow the savepoint name to be reused. Name the second savepoint B and do not allow the name to be reused. Because you no longer need savepoint A when you are ready to set the third savepoint, reuse A as the name of the savepoint.

```
SAVEPOINT A ON ROLLBACK RETAIN CURSORS;  
:  
SAVEPOINT B UNIQUE ON ROLLBACK RETAIN CURSORS;  
:  
SAVEPOINT A ON ROLLBACK RETAIN CURSORS;
```

SELECT statement

The *select-statement* is the form of a query that can be directly specified in a DECLARE CURSOR statement, or prepared and then referenced in a DECLARE CURSOR statement. It can also be issued interactively using SPUFI or the command line processor which causes a result table to be displayed at your terminal. In any case, the table specified by *select-statement* is the result of the fullselect.

Authorization for SELECT

See [“Authorization for queries” on page 1007](#).

Syntax for *select-statement*

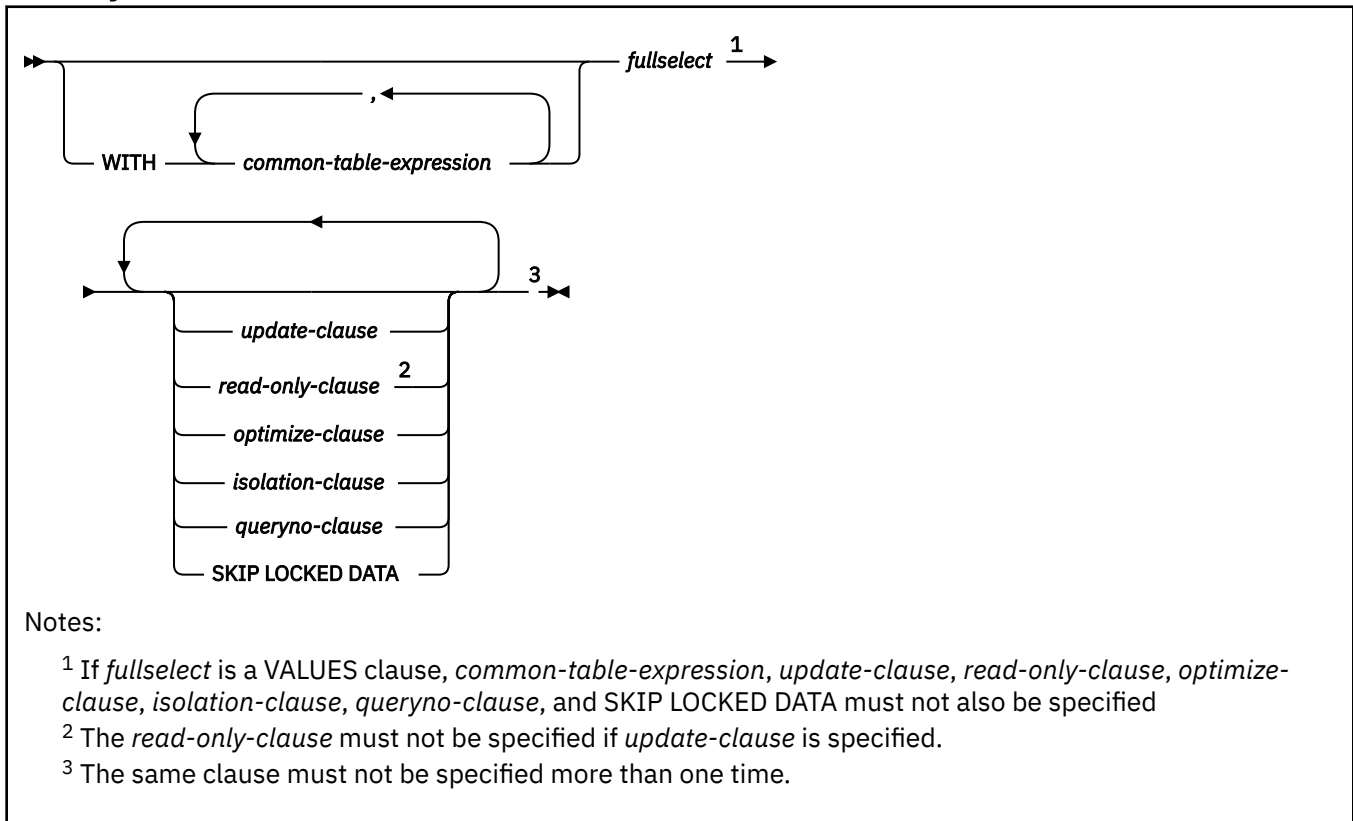

Description for *select-statement*

The *select-statement* is the form of a query that can be directly specified in a DECLARE CURSOR statement or FOR statement, prepared and then referenced in a DECLARE CURSOR statement, or directly specified in an SQLJ assignment clause. It can also be issued using SPUFI or the command line processor which causes a result table to be displayed at your terminal. In any case, the result table specified by a *select-statement* is the result of the *fullselect*. For more information, see [“select-statement” on page 1067](#).

The tables and view identified in a select statement can be at the current server or any Db2 subsystem with which the current server can establish a connection.

For local queries on Db2 for z/OS or remote queries in which the server and requester are Db2 for z/OS, if a table is encoded as ASCII or Unicode, the retrieved data is encoded in EBCDIC. For information on retrieving data encoded in ASCII or Unicode, see [Distributed queries against ASCII or Unicode tables \(Db2 Application programming and SQL\)](#).

A select statement can implicitly or explicitly invoke user-defined functions or implicitly invoke stored procedures. This technique is known as *nesting* of SQL statements. A function or procedure is implicitly invoked in a select statement when it is invoked at a lower level. For instance, if you invoke a user-defined function from a select statement and the user-defined function invokes a stored procedure, you are implicitly invoking the stored procedure.

Syntax for *fullselect*

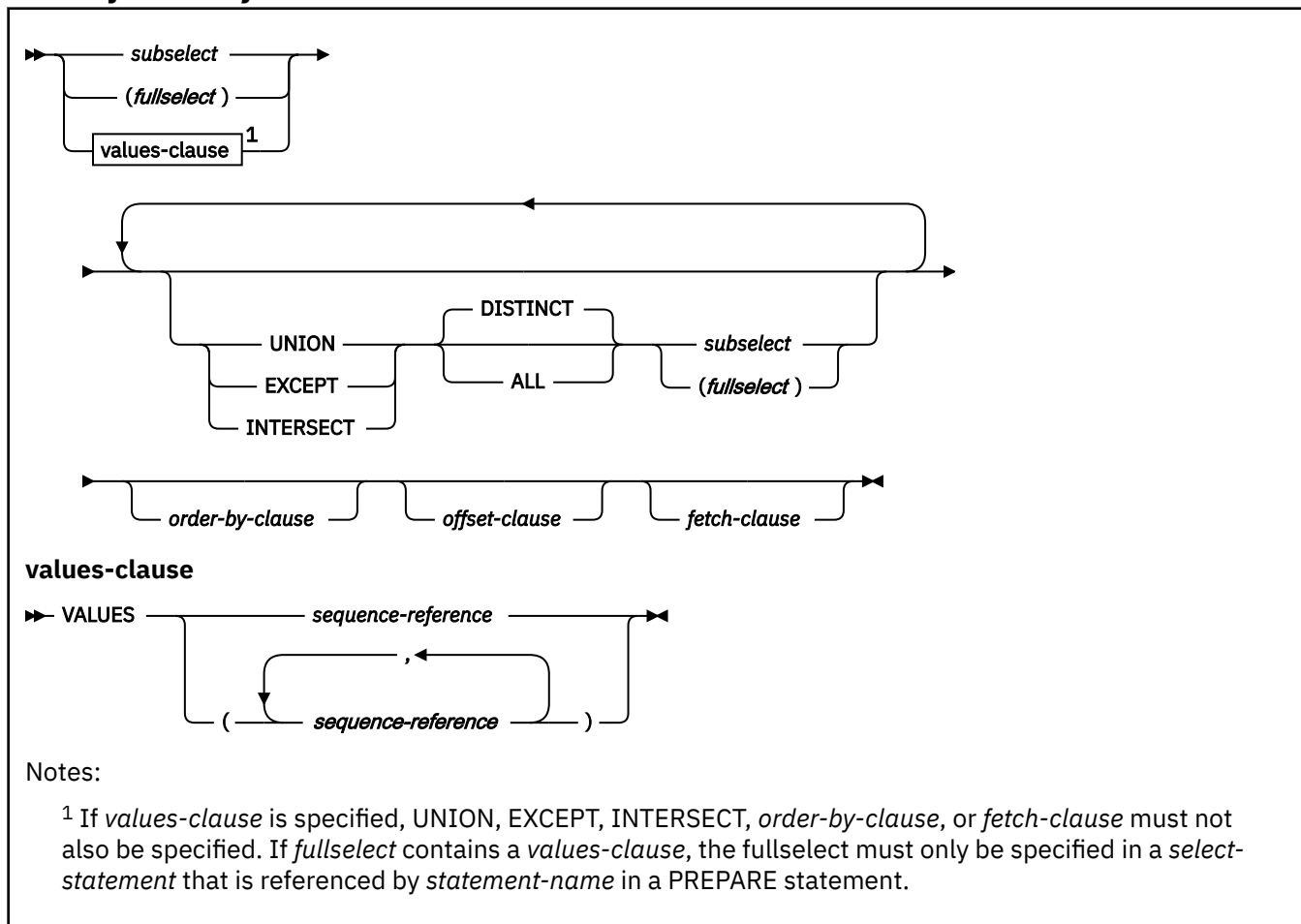

Description for *fullselect*

The *fullselect* is a component of the *select-statement*, *ALTER TABLE* statement for the definition of a materialized query table, *CREATE TABLE* statement, *CREATE VIEW* statement, *DECLARE GLOBAL TEMPORARY TABLE* statement, *INSERT* statement, *UPDATE* statement, and *MERGE* statement. For more information, see “[fullselect](#)” on page 1060

Syntax for *subselect*

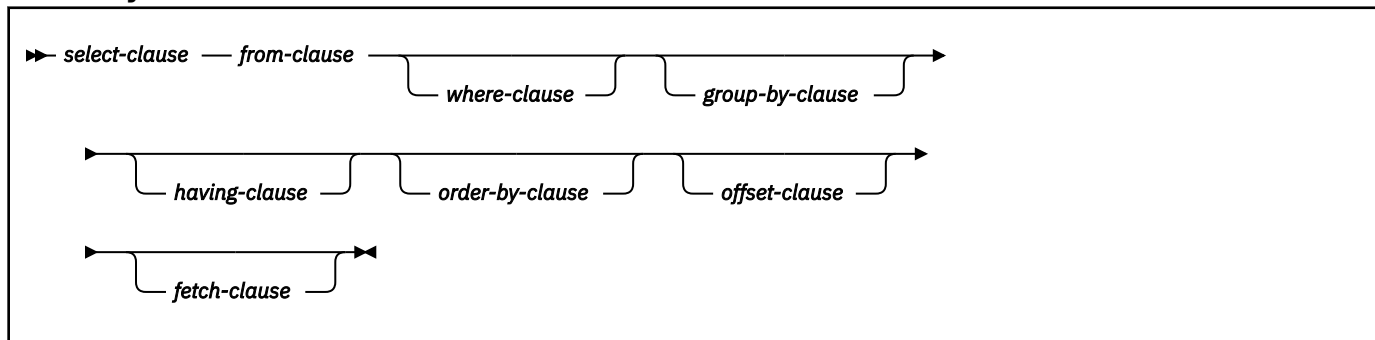

Description for *subselect*

The *subselect* is a component of the *fullselect*. A *subselect* specifies a result table that is derived from the tables or views that are identified in the *FROM* clause. For more information, see “[subselect](#)” on page 1009.

Related concepts

Queries

A *query* specifies a result table or an intermediate table. A query is a component of certain SQL statements.

SELECT INTO statement

The SELECT INTO statement produces a result table that contains at most one row. The statement assigns the values in that row to variables. If the table is empty, the statement does not assign values to the host variables or global variables.

Invocation for SELECT INTO

This statement can only be embedded in an application program. It is an executable statement that cannot be dynamically prepared.

Authorization for SELECT INTO

The privilege set that is defined below must include at least one of the following:

- The SELECT privilege on every table and view identified in the statement
- Ownership of every table and view identified in the statement
- READ privileges on any global variables that are identified in the statement
- Ownership of any global variables that are identified in the statement
- DBADM authority for the database (tables only)
- DATAACCESS authority
- SYSADM authority
- SYSCTRL authority (catalog tables only)

If the SELECT INTO statement includes an SQL data change statement, the privilege set must also include at least the privileges (INSERT, UPDATE, or DELETE) that are associated with that SQL data change statement on the table or view.

For an assignment to a global variable or an element of an array global variable, the privilege set must include at least one of the following:

- The WRITE privilege on the variable
- Ownership of the variable
- DATAACCESS authority
- SYSADM authority

For an assignment to a transition variable, the privilege set must include at least one of the following:

- The UPDATE privilege on the table or view on which the trigger that contains the assignment statement is defined
- The UPDATE privilege on the column corresponding to the transition variable to be assigned a value
- Ownership of the table or view on which the trigger that contains the assignment statement is defined
- DBADM authority on the database that contains the table on which the trigger that contains the assignment statement is defined
- DATAACCESS authority
- SYSADM authority

Privilege set: If the statement is embedded in an application program, the privilege set is the privileges that are held by the owner of the package. If the statement is dynamically prepared, the privilege set is determined by the DYNAMICRULES behavior in effect (run, bind, define, or invoke) and is summarized in [DYNAMICRULES behaviors and authorization checking](#). For more information on these behaviors,

including a list of the DYNAMICRULES bind option values that determine them, see [“Authorization IDs and dynamic SQL”](#) on page 94.

Syntax for SELECT INTO

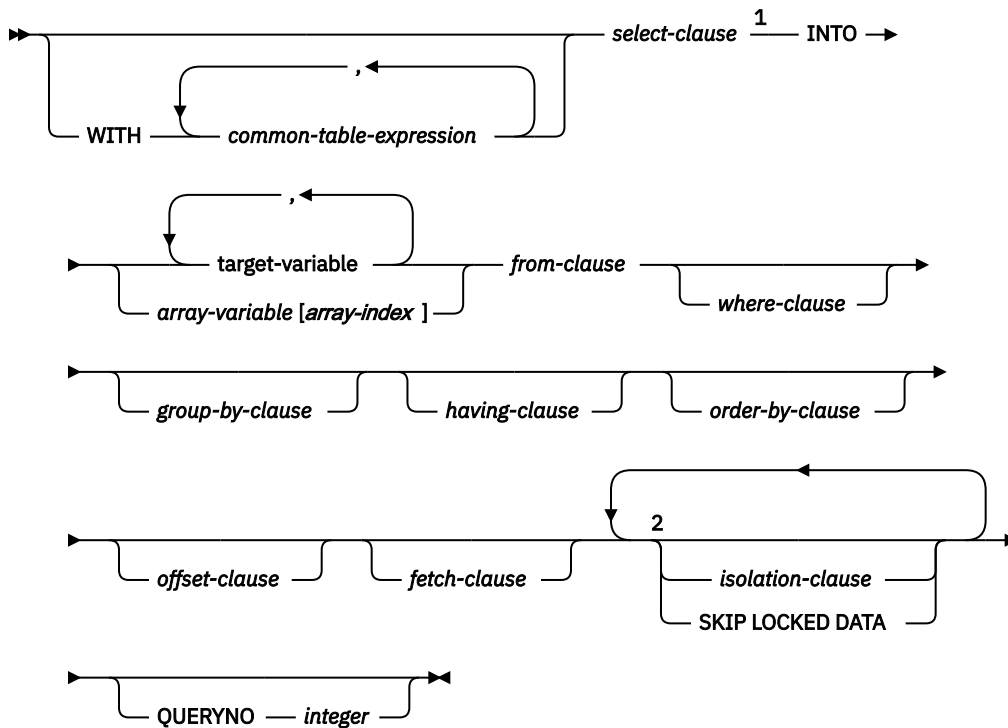

target-variable

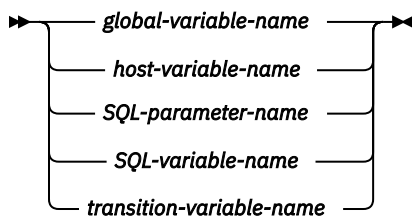

Notes:

- ¹ The `select-clause` cannot reference both a system-period temporal table and an archive-enabled table.
- ² The same clause must not be specified more than once.

Description for SELECT INTO

The result table is derived by logically evaluating the `isolation-clause`, `from-clause`, `where-clause`, `group-by-clause`, `having-clause`, `order-by-clause`, `offset-clause`, `fetch-clause`, and the `select-clause`, in this order. The actual order might be slightly different based on the plan that is chosen by the Db2 subsystem. See the topics under [Chapter 6, “Queries,”](#) on page 1007 for a description of these clauses.

The tables or views identified in the statement can exist at the current server or at any Db2 subsystem with which the current server can establish a connection.

WITH common-table-expression

Refer to [“common-table-expression”](#) on page 1069 for information about specifying a `common-table-expression`.

INTO target-variable or array-variable[array-index]

Identifies one or more targets for the assignment of output values. The number of targets in the INTO clause must equal the number of values that are to be assigned. The first value in the result row is assigned to the first target in the list, the second value to the second target, and so on. A target variable must not be specified more than once in the INTO clause. Each assignment to a target is made in sequence through the list, according to the rules described in [“Assignment and comparison” on page 143](#).

The value 'W' is assigned to the SQLWARN3 field of the SQLCA if the number of targets is less than the number of result column values.

If an error occurs on any assignment, the value is not assigned to the target, and no more values are assigned to the specified targets. Any values that have already been assigned remain assigned.

global-variable-name

Identifies the global variable that is the assignment target.

host-variable-name

Identifies the host variable that is the assignment target. For LOB output values, the target can be a regular host variable (if it is large enough), a LOB locator variable, or a LOB file reference variable.

SQL-parameter-name

Identifies the parameter that is the assignment target.

SQL-variable-name

Identifies the SQL variable that is the assignment target. SQL variables must be declared before they are used.

transition-variable-name

Identifies the column that is to be updated in the transition table. A *transition-variable-name* must identify a column in the subject table of a trigger, optionally qualified by a correlation name that identifies the new value.

array-variable [array-index]

Specifies an array element that is the target of the assignment.

An array element must not be specified as the target for an assignment if *common-table-expression* is also specified in the statement.

array-variable

Specifies an array variable.

[array-index]

An expression that specifies which element in the array is the target of the assignment.

For an ordinary array, the array index expression must be castable to INTEGER, and must not be the null value. The index value must be between 1 and the maximum cardinality that is defined for the array.

For an associative array, the array index expression must be castable to the index data type of the associative array, and must not be the null value.

array-index must not be:

- An expression that references the CURRENT DATE, CURRENT TIME, or CURRENT TIMESTAMP special register
- A nondeterministic function
- A function that is defined with EXTERNAL ACTION
- A function that is defined with MODIFIES SQL DATA
- A sequence expression
- A column that is not in a scalar fullselect.

The data type of a variable must be compatible with the value assigned to it. If the value is numeric, the variable must have the capacity to represent the integral part of the value. For a date or time

value, the variable must be a character string variable of a minimum length as defined in [“Assignment and comparison”](#) on page 143.

Each assignment to a variable is made according to the rules described in [“Assignment and comparison”](#) on page 143. Assignments are made in sequence through the list.

If an error occurs as the result of an arithmetic expression in the SELECT list of a SELECT INTO statement (division by zero or overflow) or a numeric conversion error occurs, the result is the null value. As in any other case of a null value, an indicator variable must be provided and the main variable is unchanged. In this case, however, the indicator variable is set to -2. Processing of the statement continues as if the error had not occurred. (However, this error causes a positive SQLCODE.) If you do not provide an indicator variable, a negative value is returned in the SQLCODE field of the SQLCA. Processing of the statement terminates when the error is encountered.

If an error occurs, no value is assigned to the variable or to later variables, though any values that have already been assigned to variables remain assigned.

If an error occurs because the result table has more than one row, values might be assigned to the variables. If values are assigned to the variables, the row that is the source of the values is undefined and not predictable.

SKIP LOCKED DATA

Specifies that rows are skipped when incompatible locks are held on the row by other transactions. These rows can belong to any accessed table that is specified in the statement. SKIP LOCKED DATA can be used only when isolation CS or RS is in effect and applies only to row level or page level locks.

SKIP LOCKED DATA is ignored if it is specified when the isolation level that is in effect is repeatable read (WITH RR) or uncommitted read (WITH UR).

QUERYNO *integer*

Specifies the number to be used for this SQL statement in EXPLAIN output and trace records. The number is used for the QUERYNO columns of the plan tables for the rows that contain information about this SQL statement. This number is also used in the QUERYNO column of the SYSIBM.SYSSTMT and SYSIBM.SYSPACKSTMT catalog tables.

If the clause is omitted, the number associated with the SQL statement is the statement number assigned during precompilation. Thus, if the application program is changed and then precompiled, that statement number might change.

Using the QUERYNO clause to assign unique numbers to the SQL statements in a program is helpful:

- For simplifying the use of optimization hints for access path selection
- For correlating SQL statement text with EXPLAIN output in the plan table

For more information about enabling and using optimization hints,, see [Influencing access path selection \(Db2 Performance\)](#).

Notes for SELECT INTO

Assignment to targets

The *n*th target identified by the INTO clause or described in the SQLDA corresponds to the *n*th column of the result table of the cursor. The data type of target must be compatible with its corresponding value. If the value is numeric, the target must have the capacity to represent the whole part of the value. For a datetime value, the target must be a character string variable of a minimum length as defined in [“String representations of datetime values”](#) on page 120. When the target is a host variable, if the value is null, an indicator variable must be specified.

Assignments are made in sequence through the list. Each assignment to a target is made according to the rules described in [Chapter 2, “Language elements in SQL,”](#) on page 75. If the number of targets is less than the number of values in the row, the SQLWARN3 field of the SQLCA is set to 'W'. There is no warning if there are more targets than the number of result columns. If the target is a host variable and the value is null, an indicator variable must be provided. If an assignment error occurs, the value

is not assigned to the target and no more values are assigned to targets. Any values that have already been assigned to targets remain assigned.

If more than one assignment is included in the same assignment statement, all expressions are evaluated before the assignments are performed. For example, a reference to a variable in an expression always uses the value of the variable prior to any assignment in the assignment statement.

Normally, you use LOB locators to assign and retrieve data from LOB columns. However, because of compatibility rules, you can also use LOB locators to assign data to targets with other data types. For more information on using locators, see [Saving storage when manipulating LOBs by using LOB locators \(Db2 Application programming and SQL\)](#).

A timestamp without time zone value must not be assigned to a timestamp with time zone target.

Default encoding scheme

The default encoding scheme for the data is the value in the bind option ENCODING, which is the option for application encoding. If this statement is used with functions such as LENGTH or SUBSTRING that are operating on LOB locators, and the LOB data that is specified by the locator is in a different encoding scheme from the ENCODING bind option, LOB materialization and character conversion occur. To avoid LOB materialization and character conversion, select the LOB data from the SYSIBM.SYSDUMMYA, SYSIBM.SYSDUMMYE, or SYSIBM.SYSDUMMYU sample table.

If the result table is empty

If the table is empty, the statement assigns +100 to SQLCODE, '02000' to SQLSTATE, and does not assign values to the host variables or global variables.

Number of rows inserted

If the SELECT INTO statement of the cursor contains an SQL data change statement, the SELECT INTO operation sets SQLERRD(3) to the number of rows inserted.

***offset-clause* considerations**

- The *offset-clause* can be used in the SELECT INTO statement when the query can result in more than a single row.
- To influence which row is returned, you can use the *order-by-clause*. When you specify the *order-by-clause*, the rows of the result are ordered, the specified number of rows are skipped, and the first row is returned. If the *fetch-clause* is not specified and the result table contains more than a single row, an error occurs.

***fetch-clause* considerations**

- The *fetch-clause* can be used in a SELECT INTO statement when the query can result in more than a single row. Specifying FETCH FIRST 1 ROW ONLY indicates that at most one row can be retrieved, regardless of how many rows are in the result table.
- Using the *fetch-clause* to explicitly limit the result table to a single row provides a way for a SELECT INTO statement to be used with a query that might return more than a single row. Using the clause helps you to avoid using a cursor when you know that you want to retrieve only one row. To influence which row is returned, you can use the *order-by-clause*. When you specify the *order-by-clause*, the rows of the result are ordered and then the first row is returned. If the *fetch-clause* is not specified and the result table contains more than a single row, an error occurs.

Examples for SELECT INTO

Example 1

Put the maximum salary in DSN8C10.EMP into the host variable MAXSALRY.

```
EXEC SQL SELECT MAX(SALARY)
        INTO :MAXSALRY
        FROM DSN8C10.EMP;
```

Example 2

Put the row for employee 528671, from DSN8C10.EMP, into the host structure EMPREC.

```
EXEC SQL SELECT * INTO :EMPREC
FROM DSN8C10.EMP
WHERE EMPNO = '528671'
END-EXEC.
```

Example 3

Put the row for employee 528671, from DSN8C10.EMP, into the host structure EMPREC. Assume that the row will be updated later and should be locked when the query executes.

```
EXEC SQL SELECT * INTO :EMPREC
FROM DSN8C10.EMP
WHERE EMPNO = '528671'
WITH RS USE AND KEEP EXCLUSIVE LOCKS
END-EXEC.
```

Example 4

Using a SELECT INTO statement, retrieve the value of INTCOL1 from table T1 into an element in array MYINTARRAY1, which is indexed by the value of the expression INTCOL2+MYINTVAR+1.

```
SELECT INTCOL1 INTO MYINTARRAY1[INTCOL2+MYINTVAR+1]
FROM T1
WHERE INTCOL1 = MYINTARRAY1[INTCOL2] ;
```

Related concepts

[Interaction between FETCH and OPTIMIZE FOR clauses \(Db2 Performance\)](#)

Related reference

[fetch-clause](#)

The *fetch-clause* limits the number of rows that can be fetched.

SET CONNECTION statement

The SET CONNECTION statement establishes the database server of the process by identifying one of its existing connections.

Invocation for SET CONNECTION

This statement can only be embedded in an application program. It is an executable statement that cannot be dynamically prepared. It must not be specified in Java.

Authorization for SET CONNECTION

None required.

Syntax for SET CONNECTION

```
►► SET CONNECTION location-name ►
                   └───┬───┘
                   └───┬───┘
                   host-variable
```

Description for SET CONNECTION

location-name or *host-variable*

Identifies the SQL connection by the specified location name or the location name contained in the host variable. If a host variable is specified:

- It must be a character string variable with a length attribute that is not greater than 16. (A C NUL-terminated character string can be up to 17 bytes.)

- It must not be followed by an indicator variable.
- The location name must be left-justified within the host variable and must conform to the rules for forming an ordinary location identifier.
- If the length of the location name is less than the length of the host variable, it must be padded on the right with blanks.

Let S denote the specified location name or the location name contained in the host variable. S must identify an existing SQL connection of the application process. If S identifies the current SQL connection, the state of S and all other connections of the application process are unchanged. The following rules apply when S identifies a dormant SQL connection.

If the SET CONNECTION statement is successful:

- SQL connection S is placed in the current state.
- S is placed in the CURRENT SERVER special register.
- Information about server S is placed in the SQLERRP field of the SQLCA. If the server is an IBM product, the information has the form *pppvrrm*.

The product identifier (PRDID) value is an 8-byte character value in *pppvrrm* format, where: *ppp* is a 3-letter product code; *vv* is the version; *rr* is the release; and *m* is the modification level. In Db2 12 for z/OS, the modification level indicates a range of function levels:

DSN12015 for V12R1M500 or higher.

DSN12010 for V12R1M100.

For more information, see [Product identifier \(PRDID\) values in Db2 for z/OS \(Db2 Administration Guide\)](#).

- Any previously current SQL connection is placed in the dormant state.

If the SET CONNECTION statement is unsuccessful, the connection state of the application process and the states of its SQL connections are unchanged.

Notes for SET CONNECTION

SET CONNECTION after CONNECT (Type 1): The use of CONNECT (Type 1) statements does not prevent the use of SET CONNECTION, but the statement either fails or does nothing because dormant SQL connections do not exist. The SQLRULES(DB2) bind option does not prevent the use of SET CONNECTION, but the statement is unnecessary because CONNECT (Type 2) statements can be used instead. Use the SET CONNECTION statement to conform to the SQL standard.

Status of locks, cursors, and prepared statements: When an SQL connection is used, made dormant, and then restored to the current state in the same unit of work, the status of locks, cursors, and prepared statements for that SQL connection reflects its last use by the application process.

Host variables: If the SET CONNECTION statement contains host variables, the contents of the host variables are assumed to be in the encoding scheme that was specified in the ENCODING parameter when the package or plan that contains the statement was bound.

Restrictions on array types and array variables: In any SQL statement other than a CALL statement, array types and array variables must not be referenced after a connection at a remote server has been established. This restriction includes an SQL statement that executes at a remote server as a result of a three-part name or alias that resolves to an object at a remote server. An exception is that an array element can be the target of a FETCH, SELECT INTO, SET *assignment-statement*, or VALUES INTO statement in an SQL routine even when the statement is executed at a remote server.

Example for SET CONNECTION

Execute SQL statements at TOROLAB1, execute SQL statements at TOROLAB2, and then execute more SQL statements at TOROLAB1.

```

EXEC SQL CONNECT TO TOROLAB1;
    -- execute statements referencing objects at TOROLAB1
EXEC SQL CONNECT TO TOROLAB2;
    -- execute statements referencing objects at TOROLAB2
EXEC SQL SET CONNECTION TOROLAB1;
    -- execute statements referencing objects at TOROLAB1

```

The first CONNECT statement creates the TOROLAB1 connection, the second CONNECT statement places it in the dormant state, and the SET CONNECTION statement returns it to the current state.

SET *assignment-statement* statement

The SET *assignment-statement* statement assigns values to variables and array elements.

Invocation for SET *assignment-statement*

This statement can be embedded in an application program or issued interactively. It is an executable statement that can be dynamically prepared if the targets of all assignments are global variables.

Authorization for SET *assignment-statement*

The privileges that are held by the privilege set must include those required to execute any of the expressions.

If a *row-subselect* is specified, see [Chapter 6, “Queries,” on page 1007](#) for an explanation of the authorization that is required for each subselect.

If a global variable or an element of an array global variable is referenced, the privilege set must include at least one of the following:

- The READ privilege on the variable
- Ownership of the variable
- DATAACCESS authority
- SYSADM authority

For an assignment to a global variable or an element of an array global variable, the privilege set must include at least one of the following:

- The WRITE privilege on the variable
- Ownership of the variable
- DATAACCESS authority
- SYSADM authority

For an assignment to a transition variable, the privilege set must include at least one of the following:

- The UPDATE privilege on the table or view on which the trigger that contains the assignment statement is defined
- The UPDATE privilege on the column corresponding to the transition variable to be assigned a value
- Ownership of the table or view on which the trigger that contains the assignment statement is defined
- DBADM authority on the database that contains the table on which the trigger that contains the assignment statement is defined
- DATAACCESS authority
- SYSADM authority

Privilege set: If the statement is embedded in an application program, the privilege set is the privileges that are held by the owner of the package. If the statement is dynamically prepared, the privilege set is

determined by the DYNAMICRULES behavior in effect (run, bind, define, or invoke) and is summarized in DYNAMICRULES behaviors and authorization checking. For more information on these behaviors, including a list of the DYNAMICRULES bind option values that determine them, see “Authorization IDs and dynamic SQL” on page 94.

Syntax for SET assignment-statement

► SET assignment-clause ◄

assignment-clause

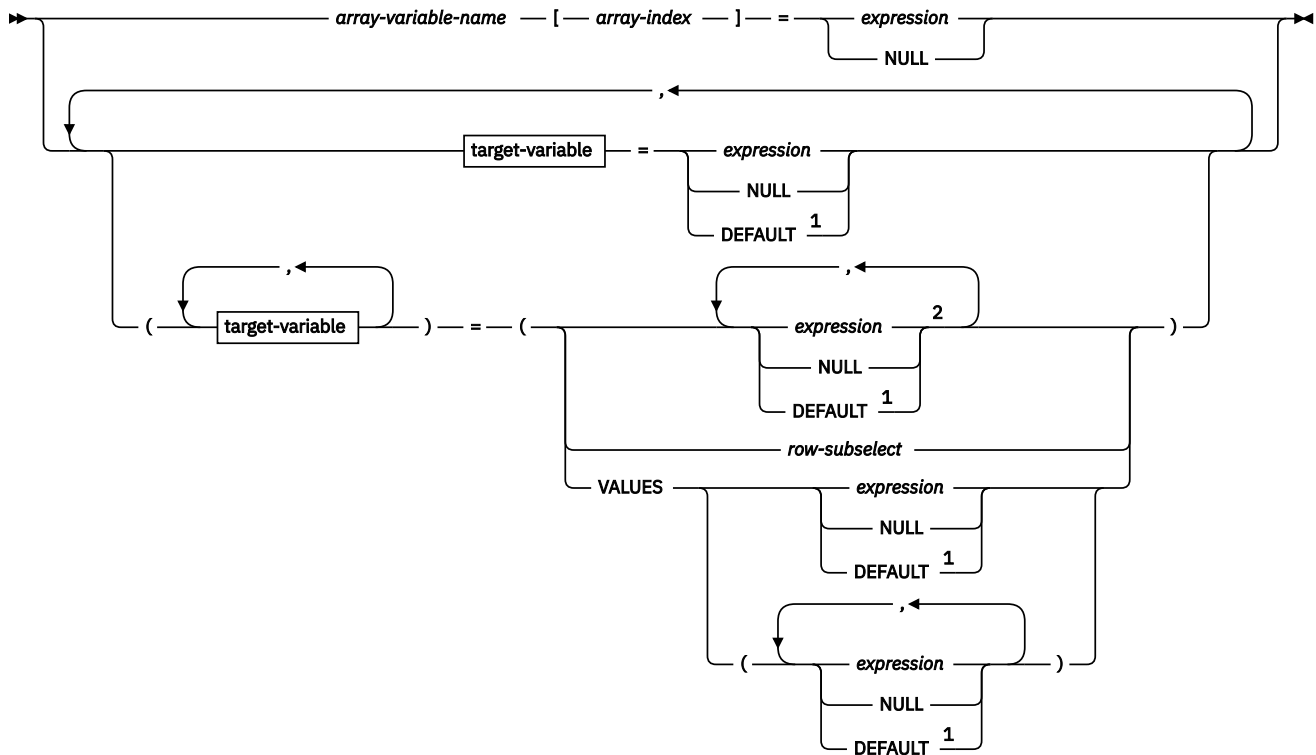

target-variable

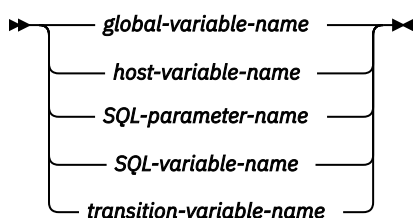

Notes:

¹ DEFAULT must only be specified when the corresponding target is a global variable or a transition variable. If DEFAULT is specified for a transition variable in an advanced trigger, then all target variables must be transition variables, and all source values must be specified with the DEFAULT keyword.

² The number of source value specifications (expression, NULL, or DEFAULT) on the right side of the equal sign must match the number of target specifications on the left side of the statement.

Description for SET assignment-statement

array-variable [*array-index*]

Specifies an array element that is the target of the assignment.

An array element must not be specified as the target for an assignment if *common-table-expression* is also specified in the statement.

array-variable

Specifies an array variable.

[array-index]

An expression that specifies which element in the array is the target of the assignment.

For an ordinary array, the array index expression must be castable to INTEGER, and must not be the null value. The index value must be between 1 and the maximum cardinality that is defined for the array.

For an associative array, the array index expression must be castable to the index data type of the associative array, and must not be the null value.

array-index must not be:

- An expression that references the CURRENT DATE, CURRENT TIME, or CURRENT TIMESTAMP special register
- A nondeterministic function
- A function that is defined with EXTERNAL ACTION
- A function that is defined with MODIFIES SQL DATA
- A sequence expression

The value that is to be assigned to an array element must be specified immediately following the array element. For example:

```
array-variable[array-index]=expression
```

expression

Specifies the value that is to be assigned to the corresponding assignment target. The expression is any expression of the type described in [“Expressions” on page 245](#). All expressions are evaluated before any result is assigned to a target. If an expression refers to a variable or array element that is used in the list of assignment targets, the value of the variable or array element in the expression is the value of the variable or array element prior to any assignments.

Each assignment to a target is made according to the assignment rules described in [“Assignment and comparison” on page 143](#). When the target variables and expressions are in the following form, the first value is assigned to the first target variable in the list, the second value is assigned to the second target variable in the list, and so on.

```
(target-variable, target-variable, ...) = (expression, expression, ...)
```

DEFAULT

Specifies that the new value for the variable is the initial default value for a global variable or the default value of a column that corresponds to a transition variable. DEFAULT can only be assigned to a global variable, or to a transition variable. If DEFAULT is specified for a transition variable in an advanced trigger, then all target variables must be transition variables, and all source values must be specified with the DEFAULT keyword.

A ROWID column must not be set to the DEFAULT keyword.

NULL

Specifies the null value and can only be specified for host variables that have an associated indicator variable.

VALUES

Specifies the values that are to be assigned to the corresponding assignment targets. When more than one value is specified, the values must be enclosed in parentheses. Each value can be an expression or NULL, as previously described. The following syntaxes are equivalent:

- (*target-variable*, *target-variable*) = (VALUES(*expression*, NULL))

- $(target\text{-}variable, target\text{-}variable) = (expression, NULL)$

A parameter marker must not be specified.

row-subselect

A subselect that returns a single row. The number of columns corresponds to the number of target variables that are specified for assignment. Each result column value is assigned to the corresponding variable. If the result of the row subselect is no rows, then null values are assigned. An error is returned if there is more than one row in the result. *row-subselect* can be specified only in the outermost subselect within SQL PL. *row-subselect* must not be specified in a basic trigger.

target-variable

Identifies one or more targets for the assignment of values. The number of targets must equal the number of values that are to be assigned.

If the statement is issued in a basic trigger, each target variable must be a transition variable.

The value that is to be assigned to each target variable can be specified immediately following the variable. For example:

```
variable=expression, variable=expression
```

Alternatively, sets of parentheses can be used to specify all of the target variables, and then all of the values. For example:

```
(variable,variable)=(expression,expression)
```

The data type of each variable in the variable list must be compatible with its corresponding result column. Each assignment to a *target-variable* is made in sequence through the list, according to the rules described in [“Assignment and comparison”](#) on page 143.

The value 'W' is assigned to the SQLWARN3 field of the SQLCA if the number of targets is less than the number of result column values.

If an error occurs on any assignment, the value is not assigned to the target, and no more values are assigned to the specified targets. Any values that have already been assigned remain assigned.

global-variable-name

Identifies the global variable that is the assignment target.

host-variable-name

Identifies the host variable that is the assignment target. For LOB output values, the target can be a regular host variable (if it is large enough), a LOB locator variable, or a LOB file reference variable.

SQL-parameter-name

Identifies the parameter that is the assignment target.

SQL-variable-name

Identifies the SQL variable that is the assignment target. SQL variables must be declared before they are used.

transition-variable-name

Identifies the column that is to be updated in the transition row. A transition variable name must identify a column in the subject table of a trigger, and is optionally qualified by a correlation name that identifies the new value.

transition-variable-name must not correspond to a begin column or end column of a BUSINESS_TIME period, and must not be specified if the statement contains a *period-clause*.

Notes for SET assignment-statement

Multiple assignments:

If more than one assignment is included in the same SET statement, all expressions and *row-subselects* are completely evaluated before the assignments are performed. Thus, references to a

target variable in an expression or *row-subselect* are always the value of the target variable prior to any assignment in the SET statement.

LOBs assignments:

Normally, you use LOB locators to assign and retrieve data from LOB columns. However, because of compatibility rules, you can also use LOB locators to assign data to targets with other data types. For more information on using locators, see [Saving storage when manipulating LOBs by using LOB locators \(Db2 Application programming and SQL\)](#).

Default encoding scheme:

The default encoding scheme for the data is the value in the bind option ENCODING, which is the option for application encoding. If this statement is used with functions such as LENGTH or SUBSTRING that are operating on LOB locators, and the LOB data that is specified by the locator is in a different encoding scheme from the ENCODING bind option, LOB materialization and character conversion occur. To avoid LOB materialization and character conversion, select the LOB data from the SYSIBM.SYSDUMMYA, SYSIBM.SYSDUMMYE, or SYSIBM.SYSDUMMYU sample table.

Examples for SET assignment-statement

Example 1: Set the host variable HVL to the value of the CURRENT PATH special register.

```
SET :HVL = CURRENT PATH;
```

Example 2: Set the host variable PATH to the contents of the SQL PATH special register, the host variable XTIME to the local time at the current server, and the host variable MEM to the current member of the data sharing environment.

```
SET :SERVER = CURRENT PATH,  
    :XTIME = CURRENT TIME,  
    :MEM = CURRENT MEMBER;
```

Example 3: Set the host variable DETAILS to a portion of a LOB value, using a LOB expression with a LOB locator to refer the extracted portion of the value.

```
SET :DETAILS = SUBSTR(:LOCATOR,1,35);
```

If the LOB data that is specified by the LOB locator LOCATOR is in a different encoding scheme from the value of the ENCODING bind option, and you want to avoid LOB materialization and character conversion, use the following statement instead of the SET statement:

```
SELECT SUBSTR(:LOCATOR,1,35)  
       INTO :DETAILS  
       FROM SYSIBM.SYSDUMMYU;
```

Example 4: Set host variable HV1 to the results of external function CALC_SALARY and host variable HV2 to the value of special register CURRENT PATH. Use an indicator value with HV1 in case CALC_SALARY returns a null value.

```
SET (:HV1:IND1, :HV2) =  
    (CALC_SALARY(:HV3, :HF4), CURRENT PATH);
```

Example 5: Assume that you want to create a before trigger that sets the salary and commission columns to default values for newly inserted rows in the EMPLOYEE table and that you will define the trigger only with NEW in the REFERENCING clause. Assign the default values to the SALARY and COMMISSION columns.

```
SET (SALARY, COMMISSION) = (50000, 8000);
```

Example 6: Assume that you want to create a before trigger that detects any commission increases greater than 10% for updated rows in the EMPLOYEE table and limits the commission increase to 10%.

You will define the trigger with both OLD and NEW in the REFERENCING clause. Limit an increase to the COMMISSION column to 10%.

```
SET NEWROW.COMMISSION = 1.1 * OLDROW.COMMISSION;
```

Example 7: Suppose that the associative array variable CANADACAPITALS has array type CAPITALSARRAY. Use SET *assignment-statement* statements to assign values to CANADACAPITALS.

```
SET CANADACAPITALS['British Columbia'] = 'Victoria';
SET CANADACAPITALS['Alberta'] = 'Edmonton';
SET CANADACAPITALS['Manitoba'] = 'Winnipeg';
SET CANADACAPITALS['Ontario'] = 'Toronto';
SET CANADACAPITALS['Nova Scotia'] = 'Halifax';
```

In the CANADACAPITALS array, the array index values are province names, and the associated array element values are the names of the corresponding capital cities. The order in which values are assigned to associative array elements does not matter. The elements of an associative array are stored in the array in ascending order of the associated array index values.

Example 8: Suppose that the associative array variables CANADACAPITALSA and CANADACAPITALSB have array type CAPITALSARRAY. The following SET *assignment-statement* statements have been used to assign values to CANADACAPITALSA.

```
SET CANADACAPITALSA['British Columbia'] = 'Victoria';
SET CANADACAPITALSA['Alberta'] = 'Edmonton';
SET CANADACAPITALSA['Manitoba'] = 'Winnipeg';
SET CANADACAPITALSA['Ontario'] = 'Toronto';
SET CANADACAPITALSA['Nova Scotia'] = 'Halifax';
```

Use a single SET *assignment-statement* statement to assign all of the values that are in CANADACAPITALSA to CANADACAPITALSB.

```
SET CANADACAPITALSB = CANADACAPITALSA;
```

Example 9: Suppose that P_PHONENUMBERS SQL array variable is defined as an ordinary array. Set P_PHONENUMBERS to an array of fixed numbers.

```
SET P_PHONENUMBERS = ARRAY[9055553907, 4165554213, 4085553678];
```

Example 10: Set the SQL array variable P_PHONENUMBERS to an array of numbers that are retrieved from the PHONENUMBER table.

```
SET P_PHONENUMBERS =
  ARRAY [SELECT NUMBER
        FROM PHONENUMBERS
        WHERE EMPID = 624];
```

Example 11: Suppose that no values have been assigned to SQL array variable P_PHONENUMBERS. Assign the value of SQL variable P_MYNUMBER to the first and tenth elements of P_PHONENUMBERS. After the first assignment, the cardinality of P_PHONENUMBERS is 1. After the second assignment, the cardinality is 10, and elements 2 to 9 have been implicitly assigned the null value.

```
SET P_PHONENUMBERS[1] = P_MYNUMBER;
SET P_PHONENUMBERS[10] = P_MYNUMBER;
```

SET CURRENT ACCELERATOR statement

The SET CURRENT ACCELERATOR statement changes the value of the CURRENT ACCELERATOR special register.

Invocation for SET CURRENT ACCELERATOR

This statement can be embedded in an application program, or it can be issued interactively. SET CURRENT ACCELERATOR is an executable statement that can be dynamically prepared.

Authorization for SET CURRENT ACCELERATOR

None required.

Syntax for SET CURRENT ACCELERATOR

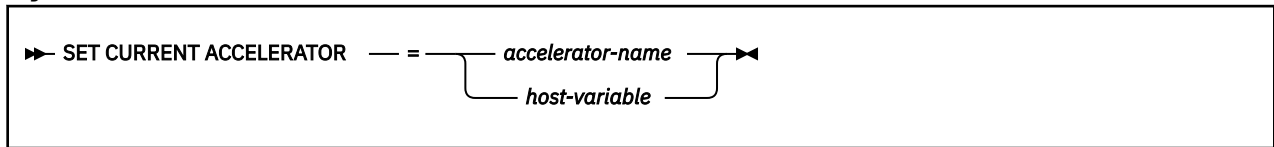

Description for SET CURRENT ACCELERATOR

accelerator-name

A character string constant that represents an accelerator name or an accelerator logical name that is recorded in SYSIBM.LOCATIONS.

host variable

A variable that represents an accelerator name or an accelerator logical name that is recorded in SYSIBM.LOCATIONS.

The accelerator name or host variable that you specify must meet these criteria:

- It must be unique within the Db2 subsystem or data sharing group.
- It must be 8 characters or fewer.
- It must consist of the characters A-Z and 0-9.

Examples for SET CURRENT ACCELERATOR

The following statement sets the CURRENT ACCELERATOR special register so that ACCEL1 is the preferred accelerator.

```
SET CURRENT ACCELERATOR = ACCEL1;
```

The following statement sets the CURRENT ACCELERATOR special register to an alias that includes two accelerators, ACCLPRO1 and ACCLPRO2.

```
INSERT INTO SYSIBM.LOCATIONS (LOCATION, LINKNAME, DBALIAS)  
VALUES ('IDAATEST', 'DSNACCELERATORALIAS', 'ACCLPRO1 ACCLPRO2');  
  
SET CURRENT ACCELERATOR = IDAATEST;
```

Related tasks

[Enabling acceleration of SQL queries \(Db2 Performance\)](#)

Related reference

[“CURRENT ACCELERATOR special register” on page 184](#)The CURRENT ACCELERATOR special register specifies a particular accelerator to which Db2 sends dynamic SQL. The CURRENT ACCELERATOR special register does not apply to static SQL.

SET CURRENT APPLICATION COMPATIBILITY statement

The SET CURRENT APPLICATION COMPATIBILITY statement assigns a value to the CURRENT APPLICATION COMPATIBILITY special register. This special register allows users to control the package compatibility level behavior for dynamic SQL.

Invocation for SET CURRENT APPLICATION COMPATIBILITY

This statement can be embedded in an application program or dynamically prepared.

Authorization for SET CURRENT APPLICATION COMPATIBILITY

None required.

Syntax for SET CURRENT APPLICATION COMPATIBILITY

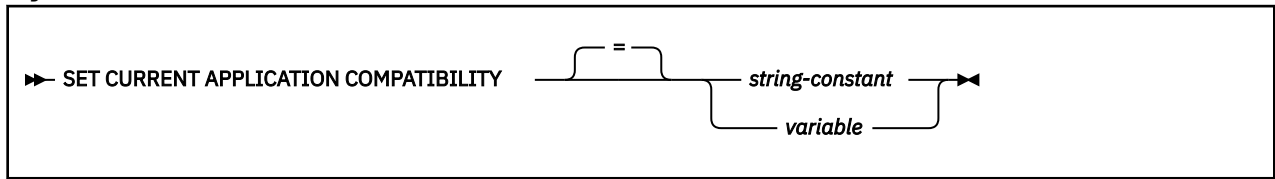

Description for SET CURRENT APPLICATION COMPATIBILITY

string-constant

Specifies a character string constant. The value must represent a valid release compatibility level, in uppercase.

variable

A variable with a data type of CHAR or VARCHAR. The value of *variable* must not be null and must represent a valid release compatibility level, in uppercase.

The value must:

- Be left-aligned within the *variable*
- Be padded on the right with blanks if its length is less than the *variable*

The following levels can be specified to set to specify the compatibility behavior of dynamic SQL statements in packages:

VvvRrMmmm

Compatibility with the behavior of the identified Db2 function level. For example, V12R1M510 specifies compatibility with the highest available Db2 12 function level. The equivalent function level or higher must be activated.

For the new capabilities that become available in each application compatibility level, see:

- [SQL changes in Db2 13 application compatibility levels](#)
- [SQL changes in Db2 12 application compatibility levels](#)

Tip: Extra program preparation steps might be required to increase the application compatibility level for applications that use data server clients or drivers to access Db2 for z/OS. For more information, see [Setting application compatibility levels for data server clients and drivers \(Db2 Application programming and SQL\)](#).

V12R1

Compatibility with the behavior of Db2 12 function level 500. This value has the same result as specifying V12R1M500.

V11R1

Compatibility with the behavior of Db2 11 new-function mode. After migration to Db2 12, this value has the same result as specifying V12R1M100. For more information, see [V11R1 application compatibility level \(Db2 Application programming and SQL\)](#)

V10R1

Compatibility with the behavior of DB2 10 new-function mode. For more information, see [V10R1 application compatibility level \(Db2 Application programming and SQL\)](#).

Notes:

- After the activation of function level 500 or higher, the source value for CURRENT APPLICATION COMPATIBILITY cannot be higher than the APPLCOMPAT bind option value.

- Function level V12R1M500 is the same as V12R1, and V12R1M100 is the same as V11R1.

Examples for SET CURRENT APPLICATION COMPATIBILITY

The following examples set the CURRENT APPLICATION COMPATIBILITY special register to 'V11R1' (in the second example, host variable HV1 = 'V11R1').

```
EXEC SQL SET CURRENT APPLICATION COMPATIBILITY = 'V11R1';
EXEC SQL SET CURRENT APPLICATION COMPATIBILITY = :HV1;
```

Related reference

[CURRENT APPLICATION COMPATIBILITY special register](#)

CURRENT APPLICATION COMPATIBILITY specifies the application compatibility level support for dynamic SQL statements in packages.

[-ACTIVATE command \(Db2\) \(Db2 Commands\)](#)

[Db2 12 function levels \(Db2 for z/OS What's New?\)](#)

SET CURRENT APPLICATION ENCODING SCHEME

The SET CURRENT APPLICATION ENCODING SCHEME statement assigns a value to the CURRENT APPLICATION ENCODING SCHEME special register. This special register allows users to control which encoding scheme will be used for dynamic SQL statements after the SET statement has been executed.

Invocation for SET CURRENT APPLICATION ENCODING SCHEME

This statement can be embedded only in an application program. It is an executable statement that cannot be dynamically prepared.

Authorization for SET CURRENT APPLICATION ENCODING SCHEME

None required.

Syntax for SET CURRENT APPLICATION ENCODING SCHEME

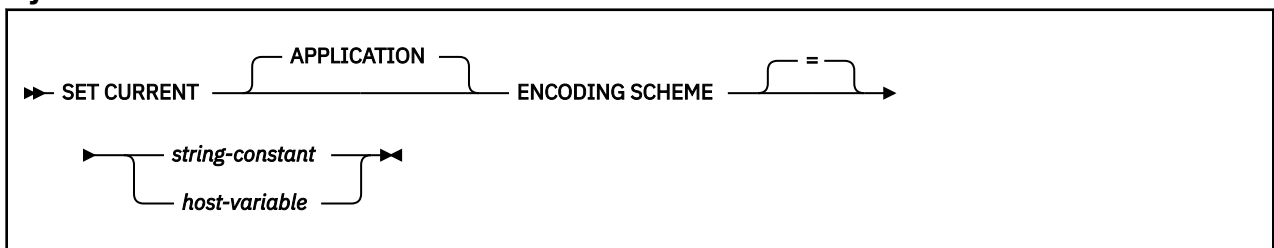

Description for SET CURRENT APPLICATION ENCODING SCHEME

string-constant

A character string constant that represents a valid encoding scheme (ASCII, EBCDIC, UNICODE, or a character representation of a number in the range 1–65533).

host variable

A variable with a data type of CHAR or VARCHAR. The value of *host-variable* must not be null and must represent a valid encoding scheme or a character representation of a number in the range 1–65533). An associated indicator variable must not be provided.

The value must:

- Be left justified within the host variable
- Be padded on the right with blanks if its length is less than that of the host variable

Examples for SET CURRENT APPLICATION ENCODING SCHEME

The following examples set the CURRENT APPLICATION ENCODING SCHEME special register to 'EBCDIC' (in the second example, Host variable HV1 = 'EBCDIC').

```
EXEC SQL SET CURRENT APPLICATION ENCODING SCHEME = 'EBCDIC';  
EXEC SQL SET CURRENT ENCODING SCHEME = :HV1;
```

Related reference

[CURRENT APPLICATION ENCODING SCHEME special register](#)

CURRENT APPLICATION ENCODING SCHEME specifies which encoding scheme is to be used for dynamic statements. It allows an application to indicate the encoding scheme that is used to process data. This register is not supported in REXX applications or in stored procedures written in REXX.

SET CURRENT DEBUG MODE statement

The SET CURRENT DEBUG MODE statement assigns a value to the CURRENT DEBUG MODE special register.

The special register sets the default value for the DEBUG MODE option for the following statements:

- CREATE FUNCTION statements that define an SQL scalar function
- ALTER FUNCTION statements that create or replace a version of an SQL scalar function
- CREATE PROCEDURE statements that define a native SQL or Java procedure
- ALTER PROCEDURE statements that create or replace a version of a native SQL procedure
- CREATE TRIGGER (advanced) statement that defines a trigger
- ALTER TRIGGER (advanced) statement that changes a trigger

Invocation for SET CURRENT DEBUG MODE

This statement can be embedded in an application program or issued interactively. It is an executable statement that can be dynamically prepared.

Authorization for SET CURRENT DEBUG MODE

None required.

Syntax for SET CURRENT DEBUG MODE

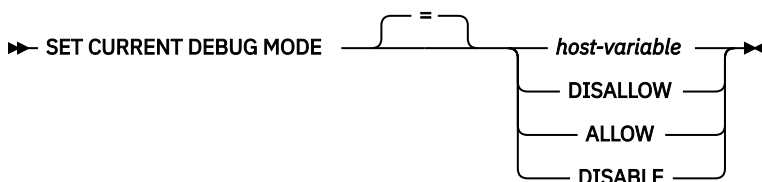

Description for SET CURRENT DEBUG MODE

host-variable

Specifies a host variable that contains the debugging option. The host variable must conform to the following rules:

- Be a CHAR, VARCHAR, GRAPHIC, or VARGRAPHIC variable. The actual length of the contents of the host variable must not exceed the length of the special register.
- Include a keyword value of DISALLOW, ALLOW, or DISABLE that is left justified
- Be padded on the right with blanks if the host variable is a fixed length character

- Not contain lowercase letters or characters that cannot be specified in an ordinary identifier
- Not be empty or contain only blanks
- Not be the null value

DISALLOW

Specifies that DISALLOW DEBUG MODE is the default option for CREATE statements when defining an SQL scalar function, native SQL procedure, Java procedure, or trigger, ALTER statements that create or replace a version of an SQL scalar function or native SQL procedure, or ALTER statements that change a trigger.

ALLOW

Specifies that ALLOW DEBUG MODE is the default option for CREATE statements when defining an SQL scalar function, native SQL procedure, Java procedure, or trigger, ALTER statements that create or replace a version of an SQL scalar function or native SQL procedure, or ALTER statements that change a trigger.

DISABLE

Specifies that DISABLE DEBUG MODE is the default option for CREATE statements when defining an SQL scalar function, native SQL procedure, Java procedure, or trigger, ALTER statements that add a version of an SQL scalar function or native SQL procedure, or ALTER statements that change a trigger.

Examples for SET CURRENT DEBUG MODE

Example: The following statement sets the CURRENT DEBUG MODE special register so that the default option for CREATE PROCEDURE statements will be ALLOW DEBUG MODE:

```
SET CURRENT DEBUG MODE = ALLOW;
```

Related reference

[CURRENT DEBUG MODE special register](#)

CURRENT DEBUG MODE specifies the default value for the DEBUG MODE option when advanced triggers and certain routines are created. The DEBUG MODE option specifies whether the trigger or routine should be built with the ability to run in debugging mode.

SET CURRENT DECFLOAT ROUNDING MODE statement

The SET CURRENT DECFLOAT ROUNDING MODE statement assigns a value to the CURRENT DECFLOAT ROUNDING MODE special register. The special register sets the default rounding mode that is used with decimal floating point values (DECFLOAT).

Invocation for SET CURRENT DECFLOAT ROUNDING MODE

This statement can be embedded in an application program or issued interactively. It is an executable statement that can be dynamically prepared.

Authorization for SET CURRENT DECFLOAT ROUNDING MODE

None required.

Syntax for SET CURRENT DECFLOAT ROUNDING MODE

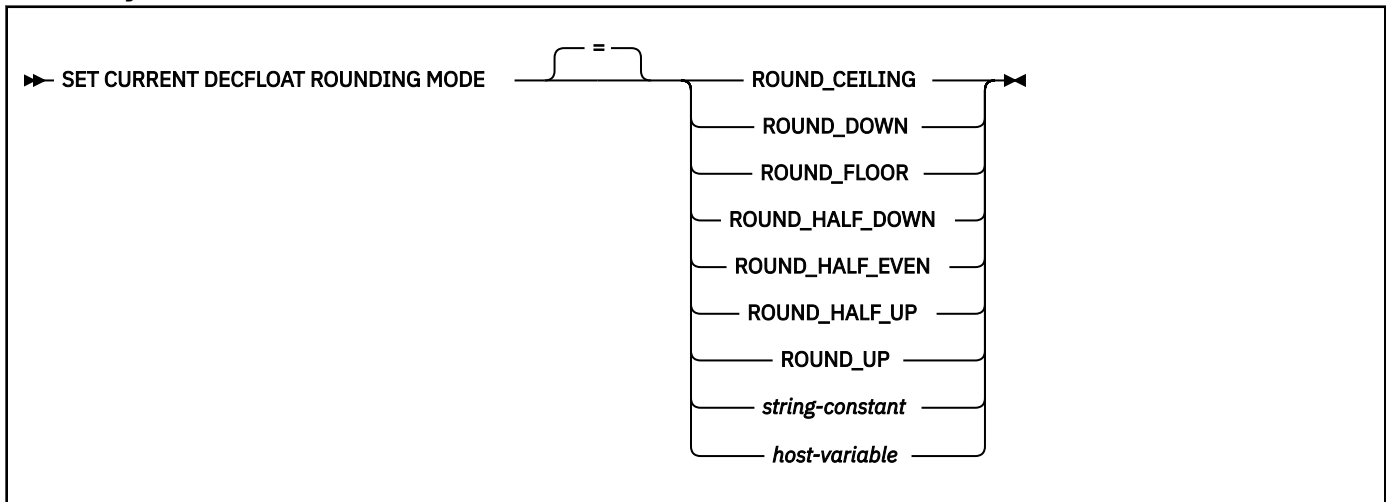

Description for SET CURRENT DECFLOAT ROUNDING MODE

ROUND_CEILING

Round towards positive infinity. If all of the discarded digits are zero or if the sign is negative, the result is unchanged other than the removal of discarded digits. Otherwise, the result coefficient is incremented by 1 (round up).

ROUND_DOWN

Round towards 0 (truncation). The discarded digits are ignored.

ROUND_FLOOR

Round towards negative infinity. If all of the discarded digits are zero or if the sign is positive, the result is unchanged other than the removal of discarded digits. Otherwise, the sign is negative and the result coefficient is incremented by 1 (round down).

ROUND_HALF_DOWN

Round to nearest value; if values are equidistant, rounds down. If the discarded digits represent greater than half (0.5) of the value of a number in the next left position, the result coefficient is incremented by 1 (round up). Otherwise, the discarded digits are ignored. This rounding mode is not recommended when creating a portable application because it is not supported by the IEEE draft standard for floating-point arithmetic.

ROUND_HALF_EVEN

Round to nearest value; if values are equidistant, round so that the final digit is even. If the discarded digits represent greater than half (0.5) of the value of a number in the next left position, the result coefficient is incremented by 1 (round up). If the discarded digits represent less than half of the value, the result coefficient is not adjusted (that is, the discarded digits are ignored). Otherwise, the result coefficient is unaltered if its rightmost digit is even, or is incremented by 1 (round up) if its rightmost digit is odd (to make an even digit).

ROUND_HALF_UP

Round to nearest value; if values are equidistant, round up. If the discarded digits represent greater than or equal to half (0.5) of the value of a number in the next left position, the result coefficient is incremented by 1 (round up). Otherwise the discarded digits are ignored.

ROUND_UP

Round away from 0. If all of the discarded digits are zero, the result is unchanged other than the removal of discarded digits. Otherwise, the result coefficient is incremented by 1 (round up). This rounding mode is not recommended when creating a portable application because it is not supported by the IEEE draft standard for floating-point arithmetic.

string-constant

Specifies a string constant that contains a specification of the rounding mode. The string-constant must have the following characteristics:

- Must be a string constant. The actual length of the contents of the string constant, after trailing blanks have been removed, must not exceed 19 characters.
- Must not be the null value.
- Must not contain lower case letters or characters that cannot be specified in an ordinary identifier.
- Must specify one of the seven rounding mode keywords as a string constant.

host-variable

Specifies a variable that contains a specification of the rounding mode. The variable must have the following characteristics:

- Must have a length, after trailing blanks have been removed, that does not exceed 19 bytes.
- Must not be followed by an indicator variable.
- Must not be a CLOB or DBCLOB.
- Must include a rounding mode that is left justified and conforms to the rules for forming an ordinary identifier.
- Must not contain lower case letters or characters that cannot be specified in an ordinary identifier.
- Must be padded on the right with blanks if the variable is a fixed length string.
- Must contain one of the seven rounding mode keywords.

Examples for SET CURRENT DECFLOAT ROUNDING MODE

Example: The following statement sets the CURRENT DECFLOAT ROUNDING MODE to ROUND_CEILING, using a string constant and a keyword.

```
SET CURRENT DECFLOAT ROUNDING MODE = ROUND_CEILING;
```

Related reference

CURRENT DECFLOAT ROUNDING MODE special register
 CURRENT DECFLOAT ROUNDING MODE specifies the default rounding mode that is used for DECFLOAT values.

SET CURRENT DEGREE statement

The SET CURRENT DEGREE statement assigns a value to the CURRENT DEGREE special register.

Invocation for SET CURRENT DEGREE

This statement can be embedded in an application program or issued interactively. It is an executable statement that can be dynamically prepared.

Authorization for SET CURRENT DEGREE

None required.

Syntax for SET CURRENT DEGREE

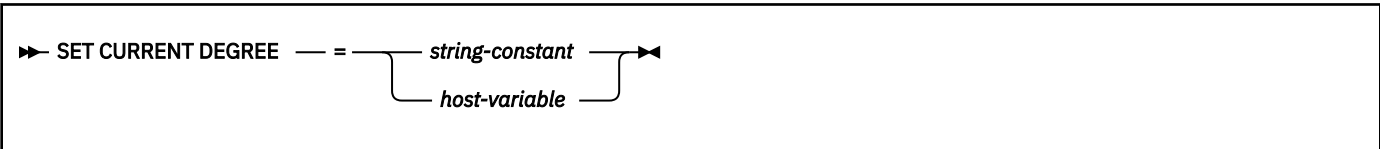

Description for SET CURRENT DEGREE

The value of CURRENT DEGREE is replaced by the value of the string constant or host variable. The value must be a character string that is not longer than 3 bytes and the value must be 'ANY', '1', or '1 '.

Notes for SET CURRENT DEGREE

If the value of CURRENT DEGREE is '1' when a query is dynamically prepared, the execution of that query will not use parallel operations. If the value of CURRENT DEGREE is 'ANY' when a query is dynamically prepared, the execution of that query can involve parallel operations.

For distributed applications, the default value at the server is used unless the requesting application issues the SQL statement SET CURRENT DEGREE. For requests using DRDA, the SET CURRENT DEGREE statement must be within the scope of the CONNECT statement.

The value specified in the SET CURRENT DEGREE statement remains in effect until it is changed by the execution of another SET CURRENT DEGREE statement or until deallocation of the application process. For applications that connect to Db2 using the call attachment facility, the value of register CURRENT DEGREE can be requested to remain in effect for a longer duration. For more information, see [CAF connection functions \(Db2 Application programming and SQL\)](#).

Examples for SET CURRENT DEGREE

Example 1: The following statement inhibits parallel operations:

```
SET CURRENT DEGREE = '1';
```

Example 2: The following statement allows parallel operations:

```
SET CURRENT DEGREE = 'ANY';
```

Related concepts

[Parallel processing \(Db2 Performance\)](#)

[Call attachment facility \(Db2 Application programming and SQL\)](#)

Related tasks

[Enabling parallel processing \(Db2 Performance\)](#)

[Disabling query parallelism \(Db2 Performance\)](#)

Related reference

[CURRENT DEGREE special register](#)

CURRENT DEGREE specifies the degree of parallelism for the execution of queries that are dynamically prepared by the application process.

[CURRENT DEGREE field \(CDSSRDEF subsystem parameter\) \(Db2 Installation and Migration\)](#)

[CONNECT statement](#)

The CONNECT statement connects an application process to a database server. This server becomes the *current server* for the process. The CONNECT statement of Db2 for z/OS is equivalent to *CONNECT (Type 2)*

in  [SQL Reference for Cross-Platform Development - Version 6](#).

SET CURRENT EXPLAIN MODE statement

The SET CURRENT EXPLAIN MODE statement assigns a value to the CURRENT EXPLAIN MODE special register.

Invocation for SET CURRENT EXPLAIN MODE

This statement can be embedded in an application program or issued interactively. It is an executable statement that can be dynamically prepared.

Authorization for SET CURRENT EXPLAIN MODE

None required.

Syntax for SET CURRENT EXPLAIN MODE

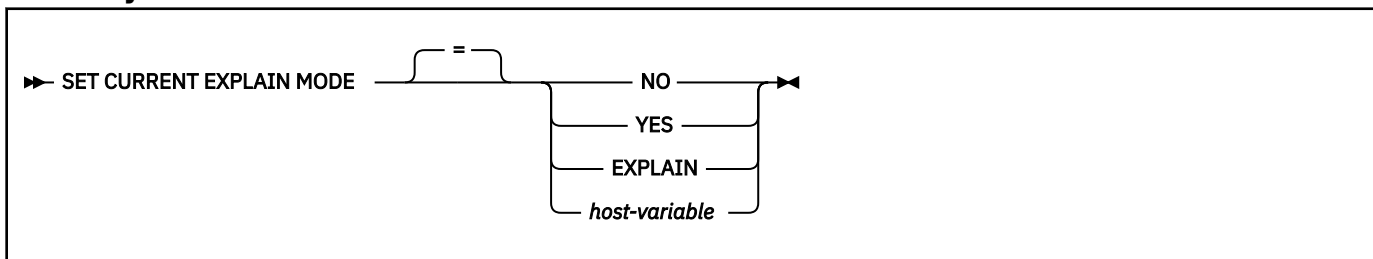

Description for SET CURRENT EXPLAIN MODE

This statement replaces the value of the CURRENT EXPLAIN MODE special register with the value of the specified keyword or host variable.

NO

Specifies that no EXPLAIN information is captured. NO is the initial value of the EXPLAIN MODE special register.

YES

Enables the EXPLAIN facility and causes EXPLAIN information to be inserted into the EXPLAIN tables for eligible dynamic SQL statements after the statement is prepared and executed. All dynamic SQL statements are compiled and executed normally.

EXPLAIN

Enables the EXPLAIN facility and causes EXPLAIN information to be captured for any eligible dynamic SQL statement after the statement is prepared. This setting behaves similarly to YES, however, dynamic statements, except for SET statements, are not executed.

host-variable

host-variable must be a CHAR or VARCHAR value and must be NO, YES, or EXPLAIN. Leading blanks are not allowed. All input values must be uppercase, must be left justified within the host variable, and must be padded on the right with blanks if the length of the value is less than the length of the host variable.

For values YES and EXPLAIN, prepared statements are not saved into the dynamic statement cache.

Examples for SET CURRENT EXPLAIN MODE

Example 1: The following statement sets the CURRENT EXPLAIN MODE special register, so that EXPLAIN information will be captured for any subsequent eligible dynamic SQL statements during execution.

```
SET CURRENT EXPLAIN MODE = YES;
```

Related reference

[CURRENT EXPLAIN MODE special register](#)

The CURRENT EXPLAIN MODE special register contains the values that control the EXPLAIN behavior in regards to eligible dynamic SQL statements.

SET CURRENT GET_ACCEL_ARCHIVE statement

The SET CURRENT GET_ACCEL_ARCHIVE statement changes the value of the CURRENT GET_ACCEL_ARCHIVE special register.

Invocation for SET CURRENT GET_ACCEL_ARCHIVE

This statement can be embedded in an application program or issued interactively. It is an executable statement that can be dynamically prepared.

Authorization for SET CURRENT GET_ACCEL_ARCHIVE

None required.

Syntax for SET CURRENT GET_ACCEL_ARCHIVE

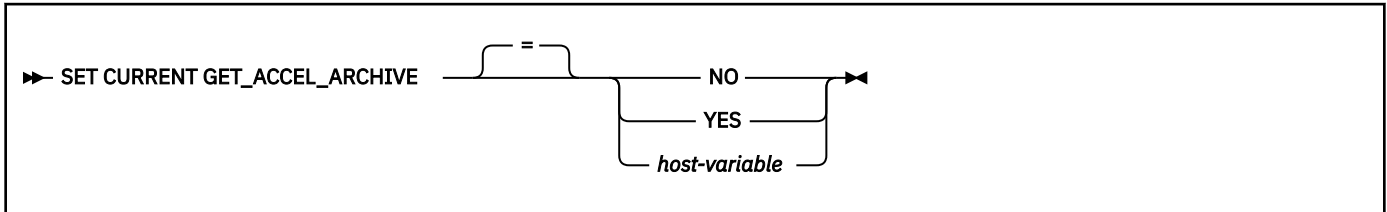

Description for SET CURRENT GET_ACCEL_ARCHIVE

NO

Specifies that if a table is archived in an accelerator server, and a query references that table, the query does not use the data that is archived.

YES

Specifies that if a table is archived in an accelerator server, and a query references that table, the query uses the data that is archived.

host-variable

A variable with a data type of CHAR or VARCHAR. The length must not exceed 255 bytes. Valid values are YES or NO. If *host-variable* has an associated indicator variable, the value of that indicator variable must not indicate a null value. The value of *host-variable* must be left justified and must be padded on the right with blanks.

Examples for SET CURRENT GET_ACCEL_ARCHIVE

The following statement sets the CURRENT GET_ACCEL_ARCHIVE special register to NO to indicate that when a table is archived in an accelerator server, the table reference does not include the archived data.

```
SET CURRENT GET_ACCEL_ARCHIVE=NO;
```

Related tasks

[Enabling acceleration of SQL queries \(Db2 Performance\)](#)

Related reference

[CURRENT GET_ACCEL_ARCHIVE special register](#)

The CURRENT GET_ACCEL_ARCHIVE special register specifies whether a dynamic SQL query that references a table that is archived on an accelerator server uses the archived data. The special register does not apply to static SQL queries.

SET CURRENT LOCALE LC_CTYPE statement

The SET CURRENT LOCALE LC_CTYPE statement assigns a value to the CURRENT LOCALE LC_CTYPE special register. The special register allows control over the LC_CTYPE locale for statements that use a built-in function that refers to a locale, such as LCASE, UCASE, and TRANSLATE (with a single argument).

Invocation for SET CURRENT LOCALE LC_CTYPE

This statement can be embedded in an application program or issued interactively. It is an executable statement that can be dynamically prepared.

Authorization for SET CURRENT LOCALE LC_CTYPE

None required.

Syntax for SET CURRENT LOCALE LC_CTYPE

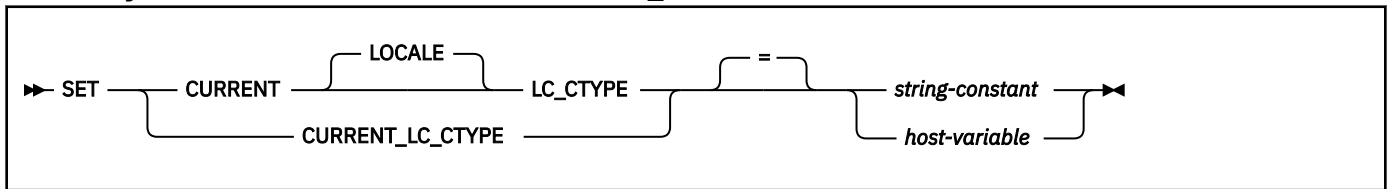

Description for SET CURRENT LOCALE LC_CTYPE

The value of CURRENT LOCALE LC_CTYPE is replaced by the value specified.

string-constant

A character string constant that must not be longer than 50 bytes and must represent a valid locale.

host-variable

A variable with a data type of CHAR or VARCHAR and a length that is not longer than 50 bytes. The value of *host-variable* must not be null and must represent a valid locale. If the host variable has an associated indicator variable, the value of the indicator variable must not indicate a null value.

The locale must:

- Be left justified within the host variable
- Be padded on the right with blanks if its length is less than that of the host variable

A locale can be specified in uppercase characters, lowercase characters, or a combination of the two. For more information, see [CURRENT LOCALE LC_CTYPE](#).

Note: The existence of a locale is not validated when the CURRENT LOCALE LC_CTYPE special register is set. For example, a locale name that is misspelled is not detected, which could affect the way subsequent SQL operates. When the special register value is used at execution time, an error is returned if the locale does not exist. For example, if the LOWER function is invoked without specifying a locale name, the special register determines the locale that is used.

Examples for SET CURRENT LOCALE LC_CTYPE

Example 1: Set the CURRENT LOCALE LC_CTYPE special register to the locale 'En_US'.

```
EXEC SQL SET CURRENT LOCALE LC_CTYPE = 'En_US';
```

Example 2: Set the CURRENT LOCALE LC_CTYPE special register to the value of host variable HV1, which contains 'Fr_FR@EURO'.

```
EXEC SQL SET CURRENT LOCALE LC_CTYPE = :HV1;
```

Related concepts

[z/OS Unicode Services User's Guide and Reference](#)

Related reference

[CURRENT LOCALE LC_CTYPE special register](#)

CURRENT LOCALE LC_CTYPE specifies the LC_CTYPE locale that will be used to execute SQL statements that use a built-in function that references a locale. Functions LCASE, UCASE, and TRANSLATE (with a single argument) refer to the locale when they are executed.

SET CURRENT MAINTAINED TABLE TYPES FOR OPTIMIZATION statement

The SET CURRENT MAINTAINED TABLE TYPES FOR OPTIMIZATION statement changes the value of the CURRENT MAINTAINED TABLE TYPES FOR OPTIMIZATION special register.

Invocation for SET CURRENT MAINTAINED TABLE TYPES FOR OPTIMIZATION

This statement can be embedded in an application program or issued interactively. It is an executable statement that can be dynamically prepared.

Authorization for SET CURRENT MAINTAINED TABLE TYPES FOR OPTIMIZATION

None required.

Syntax for SET CURRENT MAINTAINED TABLE TYPES FOR OPTIMIZATION

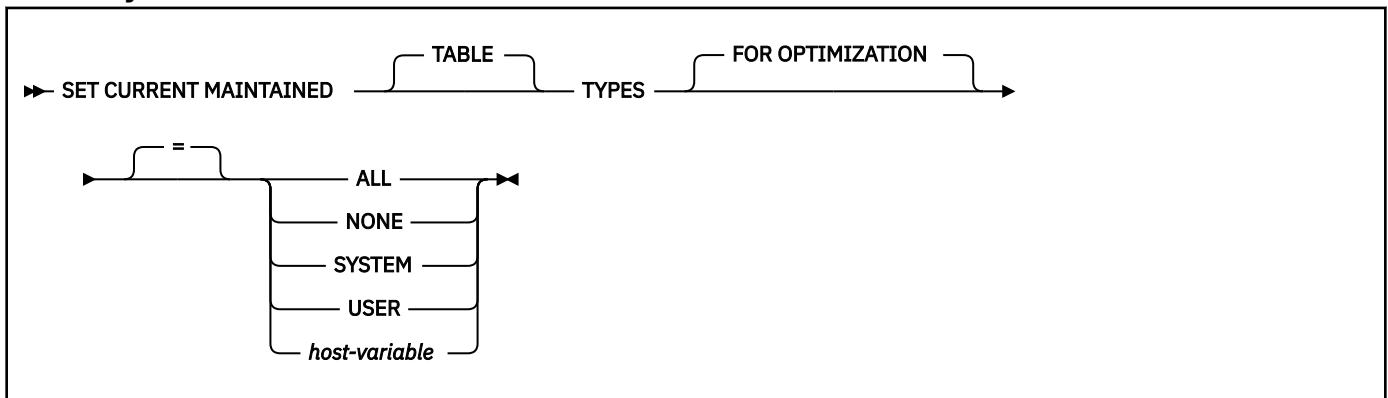

Description for SET CURRENT MAINTAINED TABLE TYPES FOR OPTIMIZATION

The value indicates which materialized query tables that are enabled for optimization are considered when optimizing the processing of dynamic SQL queries.

ALL

Indicates that all materialized query tables will be considered.

NONE

Indicates that no materialized query tables will be considered.

SYSTEM

Indicates that only system-maintained materialized query tables that are refresh deferred will be considered.

USER

Indicates that only user-maintained materialized query tables that are refresh deferred will be considered.

host-variable

A variable of type CHAR or VARCHAR. The length of the contents of *host-variable* must not exceed 255 bytes. It cannot be set to null. If *host-variable* has an associated indicator variable, the value of that indicator variable must not indicate a null value.

The characters of *host-variable* must be left justified. The content of the host variable must be a string that would match what can be specified as keywords for the special register in the exact case intended as there is no conversion to uppercase characters.

Notes for SET CURRENT MAINTAINED TABLE TYPES FOR OPTIMIZATION

The CURRENT REFRESH AGE special register needs to be set to a value other than zero in order for the specified types of objects to be considered for optimizing the processing of dynamic SQL queries.

The CURRENT MAINTAINED TABLE TYPES FOR OPTIMIZATION special register affects dynamic statement cache matching.

Examples for SET CURRENT MAINTAINED TABLE TYPES FOR OPTIMIZATION

Example 1: The following statement sets the CURRENT MAINTAINED TABLE TYPES FOR OPTIMIZATION special register:

```
SET CURRENT MAINTAINED TABLE TYPES ALL;
```

Example 2: The following example retrieves the current value of the CURRENT MAINTAINED TABLE TYPES FOR OPTIMIZATION special register into the host variable called CURMAINTYPES.

```
EXEC SQL VALUES (CURRENT MAINTAINED TABLE TYPES) INTO :CURMAINTYPES;
```

The value would be ALL if set by the previous example.

Example 3: The following example resets the CURRENT MAINTAINED TABLE TYPES FOR OPTIMIZATION special register so that no materialized query tables can be considered to optimize the processing of dynamic SQL queries.

```
SET CURRENT MAINTAINED TABLE TYPES NONE;
```

Related reference

[CURRENT MAINTAINED TABLE TYPES FOR OPTIMIZATION special register](#)

[CURRENT MAINTAINED TABLE TYPES FOR OPTIMIZATION](#) specifies a value that identifies the types of objects that can be considered to optimize the processing of dynamic SQL queries. This register contains a keyword representing table types.

SET CURRENT OPTIMIZATION HINT statement

The SET CURRENT OPTIMIZATION HINT statement assigns a value to the CURRENT OPTIMIZATION HINT special register.

Invocation for SET CURRENT OPTIMIZATION HINT

This statement can be embedded in an application program or issued interactively. It is an executable statement that can be dynamically prepared.

Authorization for SET CURRENT OPTIMIZATION HINT

None required.

Syntax for SET CURRENT OPTIMIZATION HINT

```
► SET CURRENT OPTIMIZATION HINT = string-constant | host-variable ◀
```

Description for SET CURRENT OPTIMIZATION HINT

The value of special register CURRENT OPTIMIZATION HINT is replaced by the value of the string constant or host variable. The value must be a character string that is not longer than 128 bytes.

Notes for SET CURRENT OPTIMIZATION HINT

Using the *OPTIMIZATION HINT special register*: The CURRENT OPTIMIZATION HINT special register specifies whether optimization hints are used in determining the access path of dynamic statements. An empty string or all blanks indicates that Db2 uses normal optimization techniques and ignores optimization hints.

Example for SET CURRENT OPTIMIZATION HINT

Example 1: Assume that string constant 'NOHYB' identifies a user-defined optimization hint in owner.PLAN_TABLE. Set the CURRENT OPTIMIZATION HINT special register so that Db2 uses this optimization hint to generate the access path for dynamic statements.

```
SET CURRENT OPTIMIZATION HINT = 'NOHYB';
```

If you set the register this way, Db2 validates and considers information in the rows in owner.PLAN_TABLE where the value in the OPTHINT column matches 'NOHYB' for dynamic SQL statements.

Example 2: Clear the CURRENT OPTIMIZATION HINT special register by specifying an empty string.

```
SET CURRENT OPTIMIZATION HINT = '';
```

Related reference

[CURRENT OPTIMIZATION HINT special register](#)

CURRENT OPTIMIZATION HINT specifies the user-defined optimization hint that Db2 should use to generate the access path for dynamic statements.

SET CURRENT PACKAGE PATH statement

The SET CURRENT PACKAGE PATH statement assigns a value to the CURRENT PACKAGE PATH special register.

Invocation for SET CURRENT PACKAGE PATH

This statement can be embedded only in an application program. It is an executable statement that cannot be dynamically prepared.

Authorization for SET CURRENT PACKAGE PATH

None required.

Syntax for SET CURRENT PACKAGE PATH

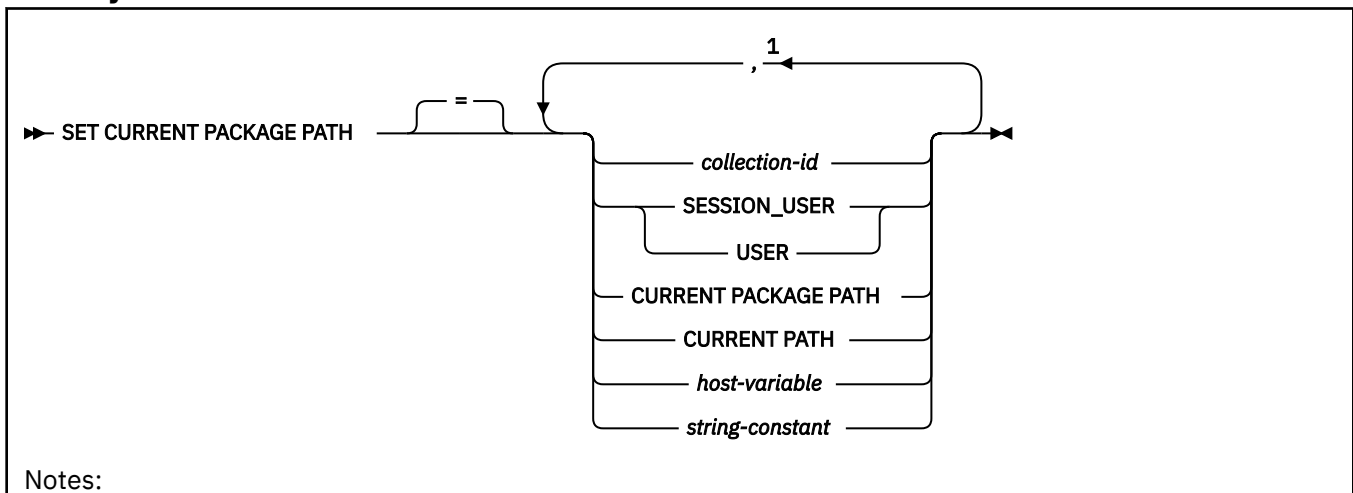

¹ SESSION_USER (or USER), CURRENT PACKAGE PATH, and CURRENT PATH can each be specified only once on the right side of the statement.

Description for SET CURRENT PACKAGE PATH

The value of CURRENT PACKAGE PATH is replaced by the values specified.

collection-id

Identifies a collection. *collection-id* must not be a delimited identifier that is empty or contains only blanks.

SESSION_USER or USER

Specifies the value of the SESSION_USER (USER) special register.

CURRENT PACKAGE PATH

Specifies the value of the CURRENT PACKAGE PATH special register before the execution of the SET CURRENT PACKAGE PATH statement.

CURRENT PATH

Specifies the value of the CURRENT PATH special register.

host-variable

Specifies a host variable that contains one or more collection IDs, separated by commas. The host variable must:

- Have a data type of CHAR or VARCHAR. The actual length of the contents of the host variable must not exceed the maximum length of the CURRENT PACKAGE PATH special register.
- Not be the null value if an indicator variable is provided.
- Contain an empty or blank string, or one or more collection IDs that are separated by commas.
- Be padded on the right with blanks if the host variable is fixed-length, or if the actual length of the host variable is longer than the content.
- Not contain a delimited identifier that is empty or contains only blanks.

string-constant

Specifies a string constant that contains one or more collection IDs, separated by commas. The string constant must:

- Have a length that does not exceed the maximum length of the CURRENT PACKAGE PATH special register.
- Contain an empty or blank string, or one or more collection IDs separated by commas.
- Not contain a delimited identifier that is empty or contains only blanks.

Notes for SET CURRENT PACKAGE PATH

Contents of host variable or string constant: The contents of a host variable or string constant are interpreted as a list of collection IDs if the value contains at least one comma. If multiple collection IDs are specified, they must be separated by commas. Each collection ID in the list must conform to the rules for forming an ordinary identifier or be specified as a delimited identifier.

Checking for the existence of collections: No validation that the collections exist is made at the time that the CURRENT PACKAGE PATH special register is set. For example, a collection ID that is misspelled is not detected, which could affect the way subsequent SQL operates. At package execution time, authorization to the specific package is checked, and if this authorization check fails, an error is issued.

Resulting contents of the special register: The special register string is built by taking each collection ID specified and removing trailing blanks, delimiting with double quotation marks, doubling any double quotation marks within the collection ID as necessary, and then separating each collection ID by a comma. If the same collection ID appears more than once in the list, the first occurrence of the collection

is used, and a warning is issued. The length of the resulting list cannot exceed the length of the special register. For example, assume that the following statements are issued:

```
SET CURRENT PACKAGE PATH = MYPKGS, "ABC E", SYSIBM  
SET :HVPKLIST = CURRENT PACKAGE PATH
```

These statements result in the value of the host variable being set to: "MYPKGS", "ABC E", "SYSIBM".

A collection ID that does not conform to the rules for an ordinary identifier must be specified as a delimited collection ID and must not be specified within a host variable or string constant.

Considerations for keywords: A difference exists between specifying a single keyword, such as SESSION_USER, as a single keyword or as a delimited identifier. To indicate that the current value of a special register that is specified as a single keyword should be used in the package path, specify the name of the special register as a keyword. If you specify the name of the special register as a delimited identifier, it is interpreted as a collection ID of that value. For example, assume that the current value of the SESSION_USER special register is SMITH and that the following statement is issued:

```
SET CURRENT PACKAGE PATH = SYSIBM, SESSION_USER, "USER"
```

The result is that the value of the CURRENT PACKAGE PATH special register is set to: "SYSIBM", "SMITH", "USER".

Specifying a collection ID in an SQL procedure: Because a host variable (SQL variable) in an SQL procedure does not begin with a colon, Db2 uses the following rules to determine whether a value that is specified in a SET PACKAGE PATH = *name* statement is a variable or a collection ID:

- If *name* is the same as a parameter or SQL variable in the SQL procedure, Db2 uses *name* as a parameter or SQL variable and assigns the value in *name* to the package path.
- If *name* is not the same as a parameter or SQL variable in the SQL procedure, Db2 uses *name* as a collection ID and assigns and the value in *name* is the package path.

DRDA classification: The SET CURRENT PACKAGE PATH statement is executed by the database server and, therefore, is classified as a non-local SET statement in DRDA. The SET CURRENT PACKAGE PATH statement requires a new level of DRDA support. If SET CURRENT PACKAGE PATH is issued when connected to the local server, the SET CURRENT PACKAGE PATH special register at the local server is set. Otherwise, when SET CURRENT PACKAGE PATH is issued when connected to a remote server, the SET CURRENT PACKAGE PATH special register at the remote server is set.

Examples for SET CURRENT PACKAGE PATH

Example 1: Set the CURRENT PACKAGE PATH special register to the list of collections COLL4 and COLL5, where :hvar1 contains the value COLL4,COLL5:

```
SET CURRENT PACKAGE PATH :hvar1;
```

The value of CURRENT PACKAGE PATH is set to the following two collection IDs: "COLL4","COLL5".

Example 2: Set the CURRENT PACKAGE PATH special register to the list of collections: COLL1, COLL#2, COLL3, COLL4, and COLL5, where :hvar1 contains the value COLL4,COLL5:

```
SET CURRENT PACKAGE PATH = "COLL1", "COLL#2", "COLL3", :hvar1;
```

The value of CURRENT PACKAGE PATH is set to the following five collection IDs: "COLL1","COLL#2","COLL3","COLL4","COLL5".

Example 3: Clear the CURRENT PACKAGE PATH special register.

```
SET CURRENT PACKAGE PATH = ' ';
```

Example 4: In preparation of calling a stored procedure that is named SUMARIZE, temporarily add two collections, COLL_PROD1" and "COLL_PROD2, to the end of the CURRENT PACKAGE PATH special

register (the values of the collections are in host variables :prodcoll1 and prodcoll2, respectively). Because the stored procedure SUMARIZE is not defined with a COLLID value and is defined with INHERIT SPECIAL REGISTERS, the stored procedure will inherit the value of CURRENT PACKAGE PATH. When the stored procedure returns, set the value of the CURRENT PACKAGE PATH special register back to its original value.

```
SET :oldCPP = CURRENT PACKAGE PATH;  
SET CURRENT PACKAGE PATH = CURRENT PACKAGE PATH, :prodcoll1, :prodcoll2;  
CALL SUMARIZE(:V1, :V2);  
SET CURRENT PACKAGE PATH = :oldCPP;
```

Related reference

[CURRENT PACKAGE PATH special register](#)

CURRENT PACKAGE PATH specifies a value that identifies the path used to resolve references to packages that are used to execute SQL statements. This special register applies to both static and dynamic statements.

SET CURRENT PACKAGESET statement

The SET CURRENT PACKAGESET statement assigns a value to the CURRENT PACKAGESET special register.

Invocation for SET CURRENT PACKAGESET

This statement can only be embedded in an application program. It is an executable statement that cannot be dynamically prepared.

Authorization for SET CURRENT PACKAGESET

None required.

Syntax for SET CURRENT PACKAGESET

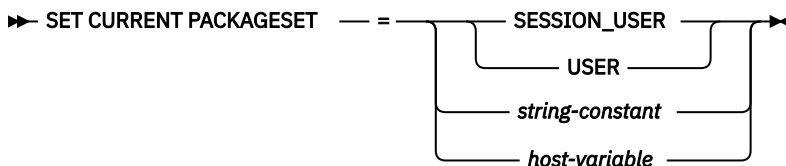

Description for SET CURRENT PACKAGESET

The value of CURRENT PACKAGESET is replaced by the value of the SESSION_USER special register, *string-constant*, or *host-variable*. The value specified by *string-constant* or *host-variable* must be a character string that is not longer than 128 bytes.

Notes for SET CURRENT PACKAGESET

Selection of plan elements: A *plan element* is a DBRM that has been bound into the plan or a package that is implicitly or explicitly identified in the package list of the plan. Plan elements contain the control structures used to execute certain SQL statements.

Since a plan can have many elements, one of the first steps involved in the execution of an SQL statement that requires a control structure is the selection of the plan element that contains its control structure. The information used by Db2 to select plan elements includes the value of CURRENT PACKAGESET.

SET CURRENT PACKAGESET is used to specify the collection ID of a package that exists at the current server. SET CURRENT PACKAGESET is optional and should not be used without an understanding of the following rules for selecting a plan element.

If the CURRENT PACKAGESET special register is an empty string, Db2 searches for a DBRM or a package in one of these sequences:

At the local location (if CURRENT SERVER is blank or explicitly names that location), the order is:

1. All DBRMs bound directly to the plan
2. All packages that have already been allocated for the application process
3. All unallocated packages explicitly named in, and all collections completely included in, the package list of the plan. The order of search is the order those packages are named in the package list.

At a remote location, the order is:

1. All packages that have already been allocated for the application process at that location
2. All unallocated packages explicitly named in, and all collections completely included in, the package list of the plan, whose locations match the value of CURRENT SERVER. The order of search is the order those packages are named in the package list.

If the special register CURRENT PACKAGESET is set, Db2 skips the check for programs that are part of the plan and uses the value of CURRENT PACKAGESET as the collection. For example, if CURRENT PACKAGESET contains COL5, then Db2 uses COL5.PROG1.*timestamp* for the search. For more information, see [Overriding the values that Db2 uses to resolve package lists \(Db2 Application programming and SQL\)](#).

DRDA classification: SET CURRENT PACKAGESET is executed by the requester and is therefore classified as a local SET statement in DRDA.

CURRENT PACKAGESET special register with stored procedures and user-defined functions: The initial value of the CURRENT PACKAGESET special register in a stored procedure or user-defined function is the value of the COLLID parameter with which the stored procedure or user-defined function was defined. If the routine was defined without a value for the COLLID parameter, the value of the special register is inherited from the calling program. A stored procedure or user-defined function can use the SET CURRENT PACKAGESET statement to change the value of the special register. This allows the routine to select the version of the Db2 package that is used to process the SQL statements in a called routine that is not defined with a COLLID value.

When control returns from the stored procedure to the calling program, the special register CURRENT PACKAGESET is restored to the value it contained before the stored procedure was called.

Examples for SET CURRENT PACKAGESET

Example 1: Limit the plan element selection to packages in the PERSONNEL collection at the current server.

```
EXEC SQL SET CURRENT PACKAGESET = 'PERSONNEL';
```

Example 2: Eliminate collections as a factor in plan element selection.

```
EXEC SQL SET CURRENT PACKAGESET = '';
```

Related reference

[CURRENT PACKAGESET special register](#)

CURRENT PACKAGESET specifies an empty string, a string of blanks, or the collection ID of the package that will be used to execute SQL statements.

SET CURRENT PRECISION statement

The SET CURRENT PRECISION statement assigns a value to the CURRENT PRECISION special register.

Invocation for SET CURRENT PRECISION

This statement can be embedded in an application program or issued interactively. It is an executable statement that can be dynamically prepared.

Authorization for SET CURRENT PRECISION

None required.

Syntax for SET CURRENT PRECISION

```
► SET CURRENT PRECISION = string-constant | host-variable ◀
```

Description for SET CURRENT PRECISION

This statement replaces the value of the CURRENT PRECISION special register with the value of the string constant or host variable. The value must be a character string 5 bytes in length. The value must be 'DEC15', 'DEC31', or 'Dpp.s', where 'pp' is either 15 or 31 and 's' is a number in the range 1–9. If the form 'Dpp.s' is used, 'pp' represents the precision that will be used with the rules that are used for DEC15 or DEC31, and 's' represents the minimum divide scale to use for division operations. The separator used in the form 'Dpp.s' can be either the '.' or the ',' character, regardless of the setting of the default decimal point.

Example for SET CURRENT PRECISION

Set the CURRENT PRECISION special register so that subsequent statements that are prepared use DEC15 rules for decimal arithmetic.

```
EXEC SQL SET CURRENT PRECISION = 'DEC15';
```

Related reference

[CURRENT PRECISION special register](#)

CURRENT PRECISION specifies the rules to be used when both operands in a decimal operation have precisions of 15 or less.

SET CURRENT QUERY ACCELERATION statement

The SET CURRENT QUERY ACCELERATION statement changes the value of the CURRENT QUERY ACCELERATION special register.

Invocation for SET CURRENT QUERY ACCELERATION

This statement can be embedded in an application program or issued interactively. It is an executable statement that can be dynamically prepared.

Authorization for SET CURRENT QUERY ACCELERATION

None required.

Syntax for SET CURRENT QUERY ACCELERATION

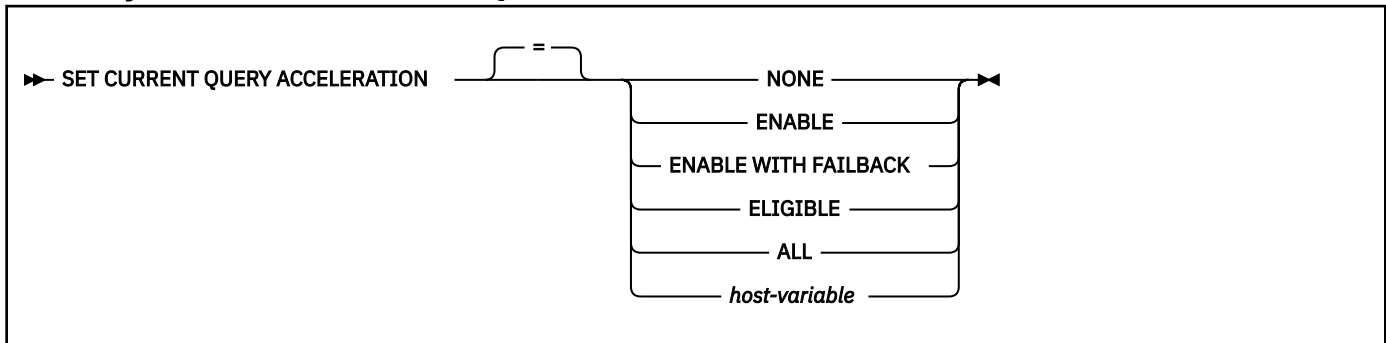

Description for SET CURRENT QUERY ACCELERATION

NONE

Specifies that no query acceleration is done.

ENABLE

Specifies that queries are accelerated only if Db2 determines that it is advantageous to do so. If an accelerator failure occurs while a query is running or if the accelerator returns an error, Db2 returns a negative SQLCODE to the application.

ENABLE WITH FAILBACK

Specifies that queries are accelerated only if Db2 determines that it is advantageous to do so. If the accelerator returns an error during the PREPARE or first OPEN for the query, Db2 executes the query without the accelerator. If the accelerator returns an error during a FETCH or a subsequent OPEN, Db2 returns the error to the user and does not execute the query.

Restriction: [FL 504](#) If the query contains a passthrough-only expression, Db2 returns an error and does not accelerate the query, even if a matching user-defined function exists. For more information about passthrough-only expressions, see [Accelerating queries with passthrough-only expressions](#).

ELIGIBLE

Specifies that queries are accelerated if they are eligible for acceleration. Db2 does not use cost information to determine whether to accelerate the queries. Queries that are not eligible for acceleration are executed by Db2. If an accelerator failure occurs while a query is running or if the accelerator returns an error, Db2 returns a negative SQLCODE to the application.

ALL

Specifies that queries are accelerated if they are eligible for acceleration. Db2 does not use cost information to determine whether to accelerate the queries. Queries that are not eligible for acceleration are not executed by Db2, and an SQL error is returned. If an accelerator failure occurs while a query is running or if the accelerator returns an error, Db2 returns a negative SQLCODE to the application.

Exceptions:

- If a dynamic query cannot be processed by IBM Db2 Analytics Accelerator because the tables do not exist on the accelerator, the query usually fails with an error message (-4742, reason code 12). However, such a query is processed by Db2 if it references tables with the following qualifiers only:
 - SYSIBM
 - SYSACCEL
 - DB2GSE
 - SYSXSR
 - DGT

- Dynamic queries whose top query block is pruned, and which therefore return an empty result set, are processed by Db2. To check whether a query falls into this category, follow these steps:
 1. Explain the query using the Db2 EXPLAIN function. Use the following special register setting in the SQL statement:

```
SET CURRENT QUERY ACCELERATION = NONE
```

2. Check the PLAN_TABLE. If the top query block has been pruned, the entry for the query block shows PRUNED in the QBLOCK_TYPE column and no value in the ACCESSTYPE column.

host-variable

A variable with a data type of CHAR or VARCHAR. The length must not exceed 255 bytes. Valid values are NONE, ENABLE, ENABLE WITH FAILBACK, ELIGIBLE, or ALL. If *host-variable* has an associated indicator variable, the value of that indicator variable must not indicate a null value. The value of *host-variable* must be left justified and must be padded on the right with blanks.

Notes for SET CURRENT QUERY ACCELERATION

The precedence order (lowest to highest) for setting the value of the special register is as follows:

- The QUERY_ACCELERATION subsystem parameter
- The QUERYACCELERATION bind option, if specified
- An explicit SET CURRENT QUERY ACCELERATION statement

Examples for SET CURRENT QUERY ACCELERATION

The following statement sets the CURRENT QUERY ACCELERATION special register to NONE to indicate that no acceleration is done.

```
SET CURRENT QUERY ACCELERATION NONE;
```

Related concepts

[How Db2 determines whether to accelerate eligible queries \(Db2 Performance\)](#)

Related tasks

[Enabling acceleration of SQL queries \(Db2 Performance\)](#)

Related reference

[CURRENT QUERY ACCELERATION special register](#)

The CURRENT QUERY ACCELERATION special register specifies a value that identifies when Db2 sends dynamic SQL queries to an accelerator server and what Db2 does if the accelerator server fails. The special register does not apply to static SQL queries.

SET CURRENT QUERY ACCELERATION WAITFORDATA statement

The SET CURRENT QUERY ACCELERATION WAITFORDATA statement assigns a value to the CURRENT QUERY ACCELERATION WAITFORDATA special register.

Invocation for SET CURRENT QUERY ACCELERATION WAITFORDATA

This statement can be embedded in an application program or issued interactively. It is an executable statement that can be dynamically prepared.

Authorization for SET CURRENT QUERY ACCELERATION WAITFORDATA

None required.

Syntax for SET CURRENT QUERY ACCELERATION WAITFORDATA

► SET CURRENT QUERY ACCELERATION WAITFORDATA = $\left[\begin{array}{c} \text{nnnn.m} \\ \text{variable} \end{array} \right]$

Description for SET CURRENT QUERY ACCELERATION WAITFORDATA

nnnn.m

Is a DECIMAL(5,1) numeric-constant value that specifies the maximum number of seconds that the accelerator will delay a query while the accelerator waits for the replication of committed Db2 data changes that occurred prior to Db2 running the query.

You can specify a value in the range of 0.0–3600.0 seconds. For example, a value of 20.0 represents 20.0 seconds (or 20000 milliseconds), and a value of 30.5 represents 30.5 seconds (or 30500 milliseconds). The maximum value of 3600.0 means that the query is delayed for 60 minutes.

The default value is 0.0, which means that the query is not delayed and is run immediately on the accelerator. Other WAITFORDATA behavior is not applied to the query.

The wait time value can also be specified as an INTEGER numeric constant value in the range 0–3600 seconds, which Db2 will convert to a DECIMAL (5,1) value.

variable

Is a language host-variable or SQL variable that has a data type of DECIMAL(5,1) or other data type that is assignable to DECIMAL(5,1). Any value that is specified for *variable* must conform to the specifications for *nnnn.m*. Additionally, *variable* cannot be a global variable.

Notes for SET CURRENT QUERY ACCELERATION WAITFORDATA

The precedence order (lowest to highest) for setting the value of the special register is as follows:

- The QUERY_ACCEL_WAITFORDATA subsystem parameter
- The ACCELERATIONWAITFORDATA bind option, if specified
- An explicit SET CURRENT QUERY ACCELERATION WAITFORDATA statement

The WAITFORDATA special register is used only for dynamic queries and applies only when query acceleration behavior is also requested by using the CURRENT QUERY ACCELERATION special register. The WAITFORDATA special register is not applied to accelerated queries that reference only accelerator-only tables (AOTs).

The delay wait time begins when the query reaches the accelerator, not when the query starts running in Db2. For more information about how to determine appropriate WAITFORDATA delay time values for query acceleration with replication in your environment, see the IBM Db2 Analytics Accelerator for z/OS documentation for Hybrid Transactional and Analytical Processing (HTAP) and the WAITFORDATA feature.

Setting CURRENT QUERY ACCELERATION WAITFORDATA to a value greater than 0 specifies that Db2 and the accelerator will apply WAITFORDATA delay behavior and restrictions to *all* dynamic queries to be accelerated afterward. The following behaviors, requirements, and restrictions apply to using WAITFORDATA to delay queries:

- When Db2 sends a query to the accelerator, Db2 also sends the specified WAITFORDATA delay wait time and an internal value that represents the latest committed Db2 data change on the entire Db2 subsystem (for a data sharing environment, across all the Db2 subsystems of the data sharing group) at the time Db2 sends the query to the accelerator. The committed data change might or might not be related to an accelerated table that is referenced in the query, but the internal value that represents this committed change is still used for the query that is accelerated.
- If the specified WAITFORDATA delay wait time expires before the expected committed Db2 data change is replicated to the accelerator, the accelerator will fail the query and issue SQLCODE -904 accompanied by additional message information.

If the delay wait time expires on the first OPEN for the query in the current Db2 unit of work, the failing query qualifies for failback to Db2 if CURRENT QUERY ACCELERATION has been set to ENABLE WITH FAILBACK.

This default WAITFORDATA delay wait time expiration behavior can be changed by modifying the accelerator configuration settings for replication. For information about changing the default WAITFORDATA delay wait time expiration behavior, see the WAITFORDATA information in the IBM Db2 Analytics Accelerator for z/OS documentation.

- All accelerated Db2 tables referenced in the query must be subscribed to and enabled for replication to the target accelerator. If all accelerated tables in the query do not meet this requirement, the accelerator will fail the query and issue SQLCODE -904 accompanied by additional message information.

If this failure occurs on the first OPEN for the query in the current Db2 unit of work, the failing query qualifies for failback to Db2 if CURRENT QUERY ACCELERATION has been set to ENABLE WITH FAILBACK.

This default WAITFORDATA behavior can be changed by modifying the accelerator configuration settings for replication. For information about changing this default WAITFORDATA behavior requirement, see the WAITFORDATA information in the IBM Db2 Analytics Accelerator for z/OS documentation.

- WAITFORDATA behavior is dependent on the replication process. Therefore, accelerated queries can be directly affected by current replication status, function, and performance, possibly resulting in the accelerated query failing on the accelerator with SQLCODE -904 if replication is not functioning or performing properly.
- In the following situations, Db2 changes that are committed before the query is sent to the accelerator will not be available to the query when it is run on the accelerator, even if WAITFORDATA delay behavior is requested for the query:
 - The query specifies a Db2 accelerated table, but the same Db2 unit of work includes a previous uncommitted Db2 change that will not be available to the query when it is run on the accelerator. In this situation, accelerator WAITFORDATA behavior cannot be achieved for the query, and the query will not be accelerated. The Db2 change might or might not be related to the Db2 accelerated table that is referenced in the query.
 - The query specifies a Db2 accelerated table, but the same Db2 unit of work includes a previous uncommitted accelerator-only table (AOT) change. This uncommitted change resulted in the creation of an accelerator database *snapshot isolation* (SI) for this unit of work before the query was run; therefore, accelerator WAITFORDATA behavior cannot be achieved for the query, and the query will not be accelerated. This accelerator database SI can prevent committed and replicated Db2 changes, made by either this transaction or by a different transaction, from being available to the accelerated query, even if the Db2 changes are replicated to the accelerator before the query is run there.

For these situations, Db2 will not accelerate the query but instead will run it only in Db2, if possible. If the QUERY ACCELERATION behavior requested does not allow the query to be run only in Db2 or if the query also references an AOT, then Db2 will fail the query and issue SQLCODE -4742. The default WAITFORDATA behavior for these situations can be changed only by modifying the transaction application with the changes that are described in the associated reason codes in SQLCODE -4742.

Examples for SET CURRENT QUERY ACCELERATION WAITFORDATA

The following statement sets the CURRENT QUERY ACCELERATION WAITFORDATA special register to 180 seconds, which specifies that the accelerator waits for the query to execute for as long as three minutes:

```
SET CURRENT QUERY ACCELERATION WAITFORDATA = 180.0;
```

The following statement sets the CURRENT QUERY ACCELERATION WAITFORDATA special register to 2.5 seconds:

```
SET CURRENT QUERY ACCELERATION WAITFORDATA = 2.5;
```

Related tasks

Enabling acceleration of SQL queries (Db2 Performance)

Related reference

[CURRENT QUERY ACCELERATION WAITFORDATA special register](#)

The CURRENT QUERY ACCELERATION WAITFORDATA special register specifies the maximum amount of time, if any, that the accelerator delays a dynamic SQL query while the accelerator waits for the replication of committed Db2 data changes that occurred prior to Db2 running the query. This special register does not apply to static SQL queries.

[WAIT FOR DATA field \(QUERY_ACCEL_WAITFORDATA subsystem parameter\) \(Db2 Installation and Migration\)](#)

[CURRENT QUERY ACCELERATION special register](#)

The CURRENT QUERY ACCELERATION special register specifies a value that identifies when Db2 sends dynamic SQL queries to an accelerator server and what Db2 does if the accelerator server fails. The special register does not apply to static SQL queries.

SET CURRENT REFRESH AGE statement

The SET CURRENT REFRESH AGE statement changes the value of the CURRENT REFRESH AGE special register.

The CURRENT REFRESH AGE value corresponding to ANY (99 999 999 999 999) cannot be used in timestamp arithmetic operations because the result would be outside the valid range of dates.

Invocation for SET CURRENT REFRESH AGE

This statement can be embedded in an application program or issued interactively. It is an executable statement that can be dynamically prepared.

Authorization for SET CURRENT REFRESH AGE

None required.

Syntax for SET CURRENT REFRESH AGE

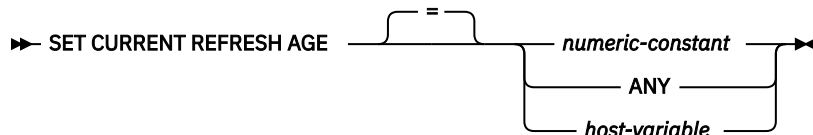

Description for SET CURRENT REFRESH AGE

numeric-constant

A DECIMAL(20,6) value representing a timestamp duration. The value must be 0 or 99 999 999 999 999, the partial seconds of which is ignored and thus can be any value.

0

Indicates that query optimization using materialized query tables will not be attempted.

9999999999999999

Indicates that any materialized query tables identified by the CURRENT MAINTAINED TABLE TYPES FOR OPTIMIZATION special register may be used to optimize the processing of a query. This value represents 9999 years, 99 months, 99 days, 99 hours, 99 minutes, and 99 seconds.

ANY

Shorthand for 9999999999999999.

host-variable

A variable of type DECIMAL(20,6) or other type that is assignable to DECIMAL(20,6). It cannot be set to null. If *host-variable* has an associated indicator variable, the value of that indicator variable must not indicate a null value. The value of *host-variable* must be 0 or 99 999 999 999 999, the partial seconds of which is ignored and thus can be any value.

Notes for SET CURRENT REFRESH AGE

Materialized query tables created or altered with DISABLE QUERY OPTIMIZATION specified are not eligible for automatic query rewrite. Thus, they are not affected by the setting of this special register.

Setting the CURRENT REFRESH AGE special register to a value other than zero should be done with caution. Allowing a materialized query table that may not represent the values of the underlying base table to be used to optimize the processing of a query may produce results that do not accurately represent the data in the underlying table. This situation may be acceptable when you know the underlying data has not changed or you are willing to accept the degree of error in the results based on your knowledge of the data.

Examples for SET CURRENT REFRESH AGE

Example: Set the CURRENT REFRESH AGE special register to 99 999 999 999 999 to indicate that any materialized query tables identified by the CURRENT MAINTAINED TABLE TYPES FOR OPTIMIZATION special register can be used to optimize the processing of a query.

```
SET CURRENT REFRESH AGE ANY;
```

Related reference

[CURRENT REFRESH AGE special register](#)

CURRENT REFRESH AGE specifies a timestamp duration value. This duration is the maximum duration since a REFRESH TABLE statement has been processed on a system-maintained REFRESH DEFERRED materialized query table such that the materialized query table can be used to optimize the processing of a query. This special register affects dynamic statement cache matching.

SET CURRENT ROUTINE VERSION statement

The SET CURRENT ROUTINE VERSION statement assigns a value to the CURRENT ROUTINE VERSION special register. The special register sets the override value for the version identifier of native SQL procedures when they are invoked.

Invocation for SET CURRENT ROUTINE VERSION

This statement can be embedded in an application program or issued interactively. It is an executable statement that can be dynamically prepared.

Authorization for SET CURRENT ROUTINE VERSION

None required.

Syntax for SET CURRENT ROUTINE VERSION

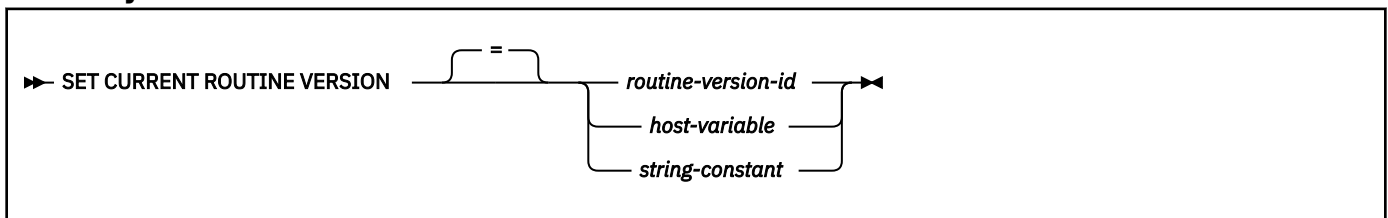

Description for SET CURRENT ROUTINE VERSION

routine-version-id

Specifies a routine version identifier.

host-variable

Specifies a host variable that contains a version identifier. The host variable must conform to the following rules:

- Be a CHAR, VARCHAR, GRAPHIC, or VARGRAPHIC variable. The actual length of the contents of the host variable must not exceed the length of a version identifier.
- Include a routine version identifier that is left justified and conforms to the rules for forming an ordinary identifier or a delimited identifier, or must be blank or empty.
- Be padded on the right with blanks if the host variable is a fixed length character.
- Not be empty or contain only blanks if the identifier is delimited.
- Not be the null value.

string-constant

Specifies a string constant that contains a version identifier. The string constant must conform to the following rules:

- Have a length that does not exceed the length of a *routine-version-id*.
- Include a routine version identifier that is left justified and conforms to the rules for forming an ordinary identifier or a delimited identifier, or must be blank or an empty string
- Not be empty or contain only blanks if the identifier is delimited

Notes for SET CURRENT ROUTINE VERSION

Resetting the special register: To reset the special register, specify an empty string constant, a string of blanks, or a host variable that is empty or contains only blanks. A routine version override is not in effect when the special register is reset.

Implications of using the special register: Setting the CURRENT ROUTINE VERSION special register to a version identifier will affect all SQL procedures that are subsequently invoked using CALL statements that specify the name of the procedure using a host variable, until the value of CURRENT ROUTINE VERSION is changed. If a version of the procedure that is identified by the version identifier in the special register exists for an SQL procedure that is being invoked, that version of the procedure is used. Otherwise, the currently active version of the procedure (as noted in the catalog) is used.

When you use the CURRENT ROUTINE VERSION special register to test a version of one or more native SQL procedures, you should use a routine version identifier that is a value other than the default value (V1) on the CREATE PROCEDURE statement. This will avoid having the special register affect more procedures that you intend when testing a new version of a procedure. For example, assume that you want to run version VER2 of procedure P1, and procedure P1 invokes another procedure, P2. If a version exists for both procedures P1 and P2 with the routine version identifier VER2, that version will be used for both procedures.

Examples for SET CURRENT ROUTINE VERSION

Example: The following statement sets the CURRENT ROUTINE VERSION special register so that the override value for the version identifier of native SQL procedures will be the value that is specified in the host variable *rvid*:

```
SET CURRENT ROUTINE VERSION = :rvid;
```

Related reference

[CURRENT ROUTINE VERSION special register](#)

CURRENT ROUTINE VERSION specifies the version identifier that is to be used when invoking a native SQL procedure. CURRENT ROUTINE VERSION is used for CALL statements that use a host variable to specify the procedure name.

SET CURRENT RULES statement

The SET CURRENT RULES statement assigns a value to the CURRENT RULES special register.

Invocation for SET CURRENT RULES

This statement can be embedded in an application program or issued interactively. It is an executable statement that can be dynamically prepared.

Authorization for SET CURRENT RULES

None required.

Syntax for SET CURRENT RULES

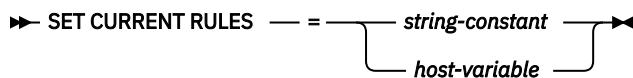

The diagram shows the syntax for the SET CURRENT RULES statement. It starts with a right-pointing arrow followed by the text 'SET CURRENT RULES'. This is followed by an equals sign. To the right of the equals sign, there are two options: 'string-constant' and 'host-variable'. Brackets connect the equals sign to each of these options, and a right-pointing arrow is at the end of the line.

Description for SET CURRENT RULES

This statement replaces the value of the CURRENT RULES special register with the value of the string constant or host variable. The value must be a character string that is 3 bytes in length, and the value must be 'DB2' or 'STD'.

Notes for SET CURRENT RULES

For the effect of the values 'DB2' and 'STD' on the execution of certain SQL statements, see [“CURRENT RULES special register”](#) on page 205.

Example for SET CURRENT RULES

Set the SQL rules to be followed to Db2 rules.

```
EXEC SQL SET CURRENT RULES = 'DB2' ;
```

Related reference

[CURRENT RULES special register](#)

CURRENT RULES specifies whether certain SQL statements are executed in accordance with Db2 rules or the rules of the SQL standard.

SET CURRENT SQLID statement

The SET CURRENT SQLID statement assigns a value to the CURRENT SQLID special register.

Invocation for SET CURRENT SQLID

This statement can be embedded in an application program or issued interactively. It is an executable statement that can be dynamically prepared. The value to which special register CURRENT SQLID is set is used as the SQL authorization ID for dynamic SQL statements only if DYNAMICRULES run behavior is in effect. The CURRENT SQLID value is ignored for the other DYNAMICRULES behaviors.

Authorization for SET CURRENT SQLID

The specified value must be equal to one of the authorization IDs of the application process. This rule always applies, even when SET CURRENT SQLID is issued as a static SQL statement.

Exceptions:

- If any of the authorization IDs of the process has SYSADM authority, CURRENT SQLID can be set to any value when the SEPARATE SECURITY system parameter is set to NO. Note that the SEPARATE_SECURITY subsystem parameter does not apply to or affect users with installation SYSADM authority.
- If any of the authorization IDs has the installation SYSOPR authority, CURRENT SQLID can be set to SYSINSTL, regardless of the SEPARATE_SECURITY value.

CURRENT SQLID cannot be set to the name of a role.

Syntax for SET CURRENT SQLID

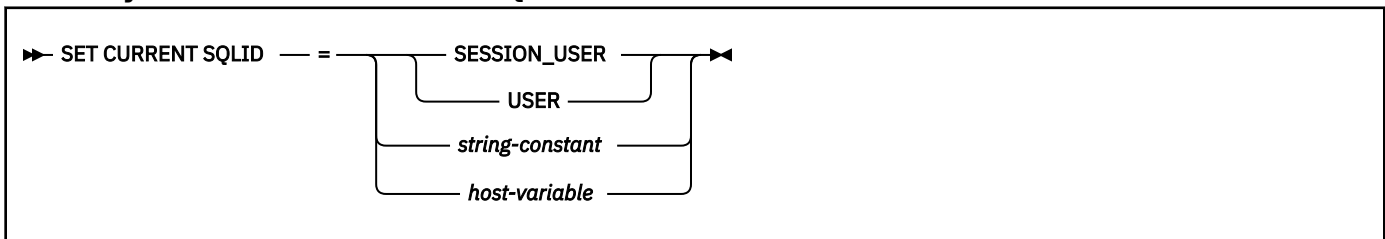

Description for SET CURRENT SQLID

The value of CURRENT SQLID is replaced based on the value that is specified. With certain exceptions, the specified value must be equal to one of the authorization IDs of the application process. For more information, see [“Authorization for SET CURRENT SQLID”](#) on page 2157.

SESSION_USER or USER

Specifies the value of the SESSION_USER (USER) special register.

string-constant

Specifies a character string constant of 8 characters or fewer that identifies an authorization ID. The content is not folded to uppercase.

host-variable

Specifies a character string constant of 8 characters or fewer that identifies a host variable that contains an authorization ID. The content is not folded to uppercase.

Notes for SET CURRENT SQLID

Effect on authorization IDs

SET CURRENT SQLID does not change the primary authorization ID of the process.

If the SET CURRENT SQLID statement is executed in a stored procedure or user-defined function package that has a dynamic SQL behavior other than run behavior, the SET CURRENT SQLID statement does not affect the authorization ID that is used for dynamic SQL statements in the package. The dynamic SQL behavior determines the authorization ID. For more information, see [DYNAMICRULES bind option \(Db2 Commands\)](#).

Effect on special register CURRENT PATH

When the value of the PATH special register depends on the value of the CURRENT SQLID special register, any changes to the CURRENT SQLID special register are not reflected in the value of the PATH special register until a commit operation is performed or a SET PATH statement is issued to change the SQL path to use the new value of the CURRENT SQLID.

DRDA classification

SET CURRENT SQLID is executed by the database server and is therefore classified as a non-local SET statement in DRDA.

Examples for SET CURRENT SQLID

Example 1

Set the CURRENT SQLID to the primary authorization ID.

```
SET CURRENT SQLID = SESSION_USER;
```

Example 2

Set the SQL authorization ID to 'GROUP34' (one of the authorization IDs of the process).

```
SET CURRENT SQLID = 'GROUP34';
```

Related reference

[CURRENT SQLID special register](#)

CURRENT SQLID specifies the SQL authorization ID of the process.

[SESSION_USER special register](#)

SESSION_USER specifies the primary authorization ID of the process.

SET CURRENT TEMPORAL BUSINESS_TIME statement

The SET CURRENT TEMPORAL BUSINESS_TIME statement changes the value of the CURRENT TEMPORAL BUSINESS_TIME special register.

Invocation for SET CURRENT TEMPORAL BUSINESS_TIME

This statement can be embedded in an application program or issued interactively. It is an executable statement that can be dynamically prepared.

Authorization for SET CURRENT TEMPORAL BUSINESS_TIME

None required.

Syntax for SET CURRENT TEMPORAL BUSINESS_TIME

```
► SET — CURRENT TEMPORAL BUSINESS_TIME — [ = ] — [ NULL ] — [ expression ] — ►
```

Description for SET CURRENT TEMPORAL BUSINESS_TIME

NULL

Specifies the null value.

expression

Specifies an expression that returns the null value or the value of one of the following built-in data types:

- Timestamp
- Character string
- Graphic string

If the expression is a character or graphic string, it must meet the following requirements:

- It must not be a CLOB or DBCLOB.
- The value of the expression must be a valid character-string or graphic-string representation of a timestamp.

- The result of the expression must be castable to `TIMESTAMP(12)`.

expression can contain any of the following supported operands:

- Constant
- Special register
- Variable (host variable, SQL parameter, SQL variable, or global variable)
- Scalar function whose arguments are supported operands
- `CAST` specification where the cast operand is a supported operand
- Expression that uses arithmetic operators and operands

For more information, see:

[“String representations of datetime values” on page 120](#)

[“Casting between data types” on page 130](#)

Notes for `SET CURRENT TEMPORAL BUSINESS_TIME`

Transactions

The `SET CURRENT TEMPORAL BUSINESS_TIME` statement is not a committable operation. The `ROLLBACK` statement has no effect on `CURRENT TEMPORAL BUSINESS_TIME`.

Effects on other special registers

The setting of the `CURRENT TEMPORAL BUSINESS_TIME` special register does not affect other special registers, such as the `CURRENT DATE` and `CURRENT TIMESTAMP` special registers.

Examples for `SET CURRENT TEMPORAL BUSINESS_TIME`

Example of setting the special register to a valid value

Both of the following statements set the `CURRENT TEMPORAL BUSINESS_TIME` special register to `'2008-01-06-00.00.00.000000000000'`.

```
SET CURRENT TEMPORAL BUSINESS_TIME = TIMESTAMP('2008-01-01') + 5 DAYS ;
SET CURRENT TEMPORAL BUSINESS_TIME = '2008-01-06-00.00.00.000000000000' ;
```

Example of how setting the special register affects subsequent SQL statements

In the following example, the first statement sets the `CURRENT TEMPORAL BUSINESS_TIME` special register to last month. Assume that table `att1` is an application-period temporal table. The setting of the `CURRENT TEMPORAL BUSINESS_TIME` special register affects the update of `att1`.

```
SET CURRENT TEMPORAL BUSINESS_TIME = CURRENT TIMESTAMP - 1 MONTH
UPDATE att1 SET c1 = 5 WHERE pk = 100
```

Assume that the `att1` table has columns `bt_begin` and `bt_end` to indicate the beginning and end of the `BUSINESS_TIME` period. In this example, Db2 interprets the `UPDATE` statement as follows:

```
UPDATE att1 SET c1 = 5 WHERE pk = 100
AND bt_begin <= CURRENT TEMPORAL BUSINESS_TIME
AND bt_end > CURRENT TEMPORAL BUSINESS_TIME
```

Example of setting the special register so that it does not affect subsequent SQL statements

The following statement sets the `CURRENT TEMPORAL BUSINESS_TIME` special register to the null value. Subsequent SQL statements that reference application-period temporal tables are not affected by the `CURRENT TEMPORAL BUSINESS_TIME` special register.

```
SET CURRENT TEMPORAL BUSINESS_TIME = NULL
```

Related concepts

[Data types](#)

Db2 supports both IBM-supplied data types (built-in data types) and user-defined data types (distinct types).

Related reference

[CURRENT TEMPORAL BUSINESS_TIME special register](#)

The CURRENT TEMPORAL BUSINESS_TIME special register specifies a TIMESTAMP(12) value that is used in the default BUSINESS_TIME period specification for references to application-period temporal tables.

SET CURRENT TEMPORAL SYSTEM_TIME statement

The SET CURRENT TEMPORAL SYSTEM_TIME statement changes the value of the CURRENT TEMPORAL SYSTEM_TIME special register.

Invocation for SET CURRENT TEMPORAL SYSTEM_TIME

This statement can be embedded in an application program or issued interactively. It is an executable statement that can be dynamically prepared.

Authorization for SET CURRENT TEMPORAL SYSTEM_TIME

None required.

Syntax for SET CURRENT TEMPORAL SYSTEM_TIME

```
►► SET — CURRENT TEMPORAL SYSTEM_TIME — [ = ] — NULL — expression ►►
```

Description for SET CURRENT TEMPORAL SYSTEM_TIME

NULL

Specifies the null value.

expression

Specifies an expression that returns the null value or the value of one of the following built-in data types:

- Timestamp
- Character string
- Graphic string

If the expression is a character or graphic string, it must meet the following requirements:

- It must not be a CLOB or DBCLOB.
- The value of the expression must be a valid character-string or graphic-string representation of a timestamp.
- The result of the expression must be castable to TIMESTAMP(12).

expression can contain any of the following supported operands:

- Constant
- Special register
- Variable (host variable, SQL parameter, SQL variable, or global variable)
- Scalar function whose arguments are supported operands
- CAST specification where the cast operand is a supported operand
- Expression that uses arithmetic operators and operands

For more information, see:

[“String representations of datetime values” on page 120](#)

[“Casting between data types” on page 130](#)

Notes for SET CURRENT TEMPORAL SYSTEM_TIME

Transactions

The SET CURRENT TEMPORAL SYSTEM_TIME statement is not a committable operation. The ROLLBACK statement has no effect on CURRENT TEMPORAL SYSTEM_TIME.

Effects on other special registers

The setting of the CURRENT TEMPORAL SYSTEM_TIME special register does not affect other special registers, such as the CURRENT DATE and CURRENT TIMESTAMP special registers.

Examples for SET CURRENT TEMPORAL SYSTEM_TIME

Example of setting the special register to a valid value

Both of the following statements set the CURRENT TEMPORAL SYSTEM_TIME special register to '2008-01-06-00.00.00.000000000000'.

```
SET CURRENT TEMPORAL SYSTEM_TIME = TIMESTAMP('2008-01-01') + 5 DAYS;  
SET CURRENT TEMPORAL SYSTEM_TIME = '2008-01-06-00.00.00.000000000000';
```

Example of setting the special register so that it does not affect subsequent SQL statements

The following statement sets the CURRENT TEMPORAL SYSTEM_TIME special register to the null value. Subsequent SQL statements that reference system-period temporal tables are not affected by the CURRENT TEMPORAL SYSTEM_TIME special register.

```
SET CURRENT TEMPORAL SYSTEM_TIME = NULL
```

Related concepts

Data types

Db2 supports both IBM-supplied data types (built-in data types) and user-defined data types (distinct types).

Related reference

[CURRENT TEMPORAL SYSTEM_TIME special register](#)

The CURRENT TEMPORAL SYSTEM_TIME special register specifies a TIMESTAMP(12) value that is used in the default SYSTEM_TIME period specification for references to system-period temporal tables.

SET ENCRYPTION PASSWORD statement

The SET ENCRYPTION PASSWORD statement sets the value of the encryption password and, optionally, the password hint. The ENCRYPT_TDES, DECRYPT_BIT, DECRYPT_CHAR, and DECRYPT_DB built-in functions use this password and password hint for data encryption unless the functions are invoked with an explicitly specified password and hint. The password is not tied to Db2 authentication and is used only for data encryption.

Invocation for SET ENCRYPTION PASSWORD

The statement can be embedded in an application program or issued interactively. It is an executable statement that can be dynamically prepared.

Authorization for SET ENCRYPTION PASSWORD

None required.

Syntax for SET ENCRYPTION PASSWORD

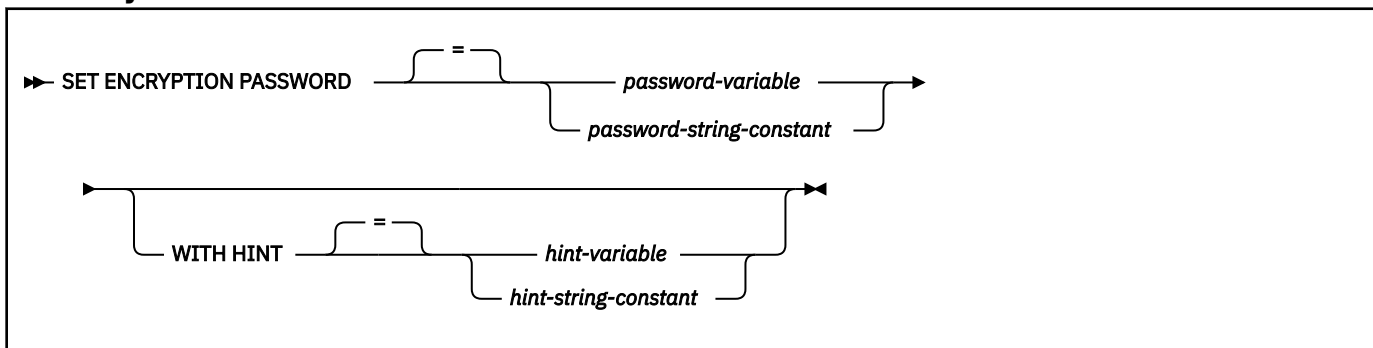

Description for SET ENCRYPTION PASSWORD

password-variable

Specifies a variable that contains an encryption password. The variable:

- Must be a CHAR or VARCHAR variable. The actual length of the contents of the variable must be in the range 6–127 inclusive or must be an empty string. If an empty string is specified, the default encryption password is set to no value.
- Must not be the null value.
- All characters are case-sensitive and are not converted to uppercase characters.

password-string-constant

A character constant that contains an encryption password. The length of the constant must be in the range 6–127 inclusive or must be an empty string. If an empty string is specified, the default encryption password is set to no value. All characters are case-sensitive and are not converted to uppercase characters.

WITH HINT

Indicates that a value is specified that will help you remember passwords (for example, 'Ocean' as a hint to remember 'Pacific'). If a hint value is specified, the hint is used as the default for encryption functions. The hint can subsequently be retrieved for an encrypted value using the GETHINT function. If this clause is not specified and a hint is not explicitly specified on the encryption function, no hint will be embedded in encrypted data result.

hint-variable

Specifies a variable that contains an encryption password hint. The variable:

- Must be a CHAR or VARCHAR variable. The actual length of the contents of the variable must not be greater than 32. If an empty string is specified, the default encryption password hint is set to an empty string.
- Must not be the null value.
- All characters are case-sensitive and are not converted to uppercase characters.

hint-string-constant

A character string constant that contains an encryption password hint. The length of the constant must not be greater than 32. If the value is an empty string, the default encryption password hint is set to an empty string.

Notes for SET ENCRYPTION PASSWORD

Normal Db2 mechanisms are used to transmit the host variable or constant to the database server.

Examples for SET ENCRYPTION PASSWORD

Example 1: Set the ENCRYPTION PASSWORD to the value in :hv1. Do not specify a hint for the password.

```
SET ENCRYPTION PASSWORD = :hv1
```

Example 2: Set the ENCRYPTION PASSWORD to the value in :hv1. Specify the value in :hv2 as the hint for the password.

```
SET ENCRYPTION PASSWORD = :hv1 WITH HINT :hv2
```

Related reference

ENCRYPTION PASSWORD special register

The ENCRYPTION PASSWORD special register specifies the encryption password and the password hint (if one exists) that are used by the ENCRYPT_TDES, DECRYPT_BIT, DECRYPT_CHAR, and DECRYPT_DB built-in functions.

ENCRYPT_TDES or ENCRYPT scalar function

The ENCRYPT_TDES function returns a value that is the result of encrypting the first argument by using the Triple DES encryption algorithm. The function can also set the password that is used for encryption.

DECRYPT_BINARY, DECRYPT_BIT, DECRYPT_CHAR, and DECRYPT_DB scalar functions

The decryption functions return a value that is the result of decrypting encrypted data. The decryption functions can decrypt only values that are encrypted by using the ENCRYPT_TDES function.

SET PATH statement

The SET PATH statement assigns a value to the CURRENT PATH special register.

Invocation for SET PATH

This statement can be embedded in an application program or issued interactively. It is an executable statement that can be dynamically prepared.

Authorization for SET PATH

None required.

Syntax for SET PATH

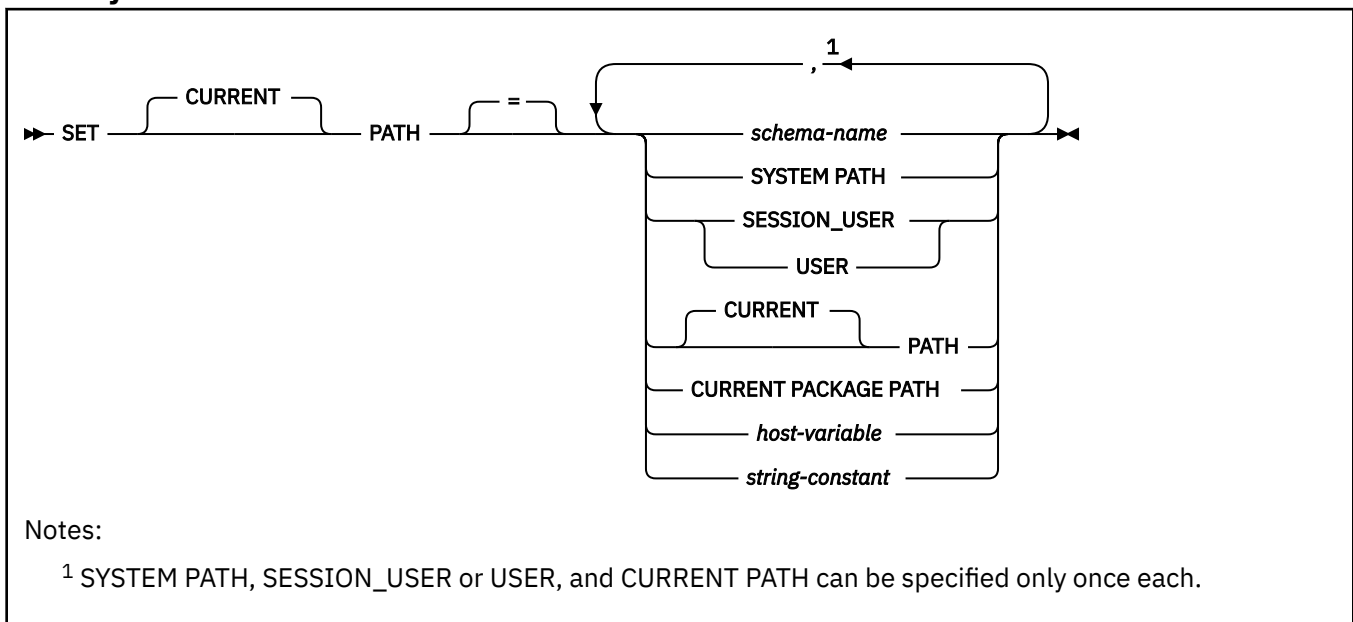

Description for SET PATH

The value of PATH is replaced by the values specified.

schema-name

Identifies a schema. Db2 does not verify that the schema exists. For example, a schema name that is misspelled is not detected, which could affect the way subsequent SQL operates.

SYSTEM PATH

Specifies the schema names "SYSIBM", "SYSFUN", "SYSPROC", "SYSIBMADM".

SESSION_USER or USER

Specifies the value of the SESSION_USER (USER) special register.

PATH

Specifies the value of the CURRENT PATH special register before the execution of this statement.

CURRENT PACKAGE PATH

Specifies the value of the CURRENT PACKAGE PATH special register.

host-variable

A variable with a data type of CHAR or VARCHAR. The value of *host-variable* must not be null and must represent a valid schema name.

The schema name must:

- Be left justified within the host variable
- Be padded on the right with blanks if its length is less than that of the host variable

string-constant

A character string constant that represents a valid schema name. The schema name must be left justified within the string constant.

If the schema name specified in *string-constant* will also be specified in other SQL statements and the schema name does not conform to the rules for ordinary identifiers, the schema name must be specified as a delimited identifier in the other SQL statements.

Notes for SET PATH**Restrictions on SET PATH:**

These restrictions apply to the SET PATH statement:

- If the same schema name appears more than one time in the path, the first occurrence of the name is used and a warning is issued.
- The length of the CURRENT PATH special register limits the number of schema names that can be specified. The special register string is built by taking each schema name that is specified and removing trailing blanks, delimiting with double quotes, changing each double quote character to two double quote characters within the schema name as necessary, and then separating each schema name with a comma. The length of the resulting string cannot exceed 2048 bytes.
- The schema name SYSPUBLIC cannot be specified in the SQL path, even if you specify the value as a delimited identifier.

Specifying "SYSIBM", "SYSFUN", "SYSPROC", "SYSIBMADM":

Schemas "SYSIBM", "SYSFUN", "SYSPROC", "SYSIBMADM" do not need to be specified in the special register. If these schemas are not explicitly specified in the CURRENT PATH special register, each schema is implicitly assumed at the front of the SQL path; if any of these schemas are not specified, they are assumed in the order of "SYSIBM", "SYSFUN", "SYSPROC", "SYSIBMADM" (see "SQL path" on page 85 for an example). Only the schemas that are explicitly specified in the CURRENT PATH register are included in the 2048 byte limit.

To avoid having "SYSIBM", "SYSFUN", "SYSPROC", "SYSIBMADM" implicitly added to the front of the SQL path, explicitly specify them in the path when setting the value of the register. If you specify them at the end of the path, Db2 will check all the other schemas in the path first.

Specifying keywords versus delimited identifiers:

There is a difference between specifying a keyword and specifying a delimited identifier. For example, specifying SESSION_USER with and without escape characters. To indicate that the value of the SESSION_USER special register should be used in the SQL path, specify the keyword SESSION_USER.

If you specify SESSION_USER is as a delimited identifier instead (for example, "SESSION_USER"), it is interpreted as a schema name of 'SESSION_USER'. For example, assume that the current value of the SESSION_USER special register is SMITH and that the following statement is issued:

```
SET PATH = SYSIBM, SYSPROC, SESSION_USER, "SESSION_USER"
```

The result is that the value of the SQL path is set to: "SYSIBM","SYSPROC","SMITH","SESSION_USER".

Specifying a schema name in an SQL procedure:

Because a host variable (SQL variable) in an SQL procedure does not begin with a colon, Db2 uses the following rules to determine whether a value that is specified in a SET PATH=*name* statement is a variable or a *schema-name*:

- If *name* is the same as a parameter or SQL variable in the SQL procedure, Db2 uses *name* as a parameter or SQL variable and assigns the value in *name* to PATH.
- If *name* is not the same as a parameter or SQL variable in the SQL procedure, Db2 uses *name* as a *schema-name* and assigns the value *name* to PATH.

The use of the path to resolve object names:

For information on when the SQL path is used to resolve unqualified data type, function, and procedure names and when the CURRENT PATH special register provides the SQL path, see [“SQL path” on page 85](#).

DRDA classification:

The SET PATH statement is executed by the database server and, therefore, is classified as a non-local SET statement in DRDA.

Alternative syntax and synonyms:

For compatibility with previous releases of Db2 or other products in the Db2 family, Db2 supports CURRENT FUNCTION PATH or CURRENT_PATH as a synonym for CURRENT PATH.

Examples for SET PATH

Example 1: Set the CURRENT PATH special register to the list of schemas: "SCHEMA1", "SCHEMA#2", "SYSIBM".

```
SET PATH = SCHEMA1, "SCHEMA#2", SYSIBM;
```

When the SQL path specified in the special register is used for name resolution the system schemas which were not explicitly specified in the special register are implicitly assumed at the front of the SQL path, making the effective value of the path:

```
SYSFUN, SYSPROC, SYSIBMADM, SCHEMA1, SCHEMA#2, SYSIBM
```

Example 2: Add schema SMITH and SYSPROC to the value of the CURRENT PATH special register that was set in Example 1.

```
SET PATH = CURRENT PATH, SMITH, SYSPROC;
```

The effective value of the SQL path specified by the special register becomes:

```
SYSFUN, SYSIBMADM, SCHEMA1, SCHEMA#2, SYSIBM, SMITH, SYSPROC
```

Related reference

[CURRENT PATH special register](#)

CURRENT PATH specifies the SQL path used to resolve unqualified data type names and function names in dynamically prepared SQL statements. It is also used to resolve unqualified procedure names that are specified as host variables in SQL CALL statements (CALL *host-variable*).

SET SCHEMA statement

The SET SCHEMA statement assigns a value to the CURRENT SCHEMA special register. If the package is bound with the DYNAMICRULES BIND option, this statement does not affect the qualifier that is used for unqualified database object references.

Invocation for SET SCHEMA

This statement can be embedded in an application program or issued interactively. It is an executable statement that can be dynamically prepared.

Authorization for SET SCHEMA

None required.

Syntax for SET SCHEMA

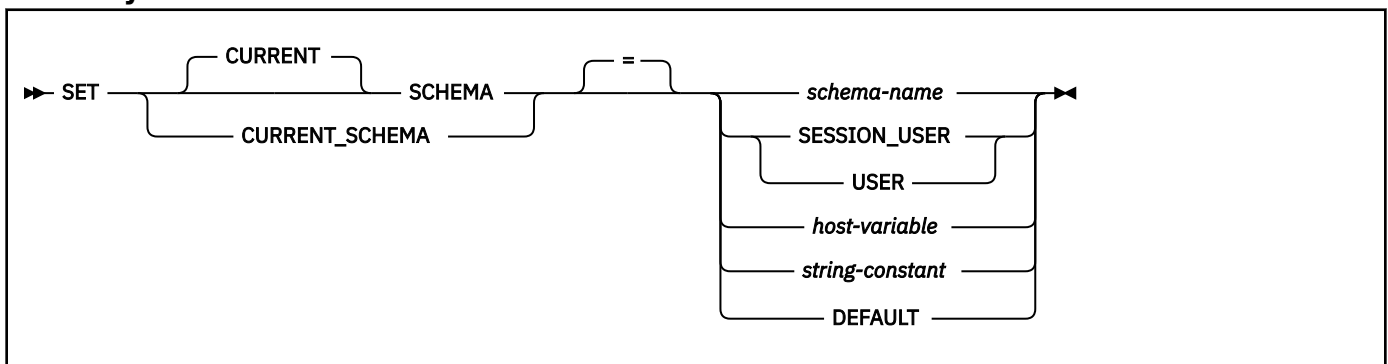

Description for SET SCHEMA

schema-name

Identifies a schema. No validation that the schema exists is made at the time the CURRENT SCHEMA is set. For example, if a schema name is misspelled, it could affect the way subsequent SQL operates.

SESSION_USER or USER

Specifies the value of the SESSION_USER (USER) special register.

host-variable

Specifies a host variable that contains a schema name. The content is not folded to uppercase.

The host variable must:

- Be a CHAR, VARCHAR, GRAPHIC, or VARGRAPHIC variable. The actual length of the contents of the *host-variable* must not exceed the length of a schema name.
- Not be set to null. If *host-variable* has an associated indicator variable, the value of that indicator variable must not indicate a null value.
- Include a schema name that is left justified and conforms to the rules for forming an ordinary identifier or delimited identifier. If the identifier is delimited, it must not be empty or contain only blanks.
- Be padded on the right with blanks if the host variable is fixed length.
- Not contain SESSION_USER, USER, or DEFAULT.

string-constant

Specifies a string constant that contains a schema name. The content is not folded to uppercase.

The string constant must:

- Have a length that does not exceed the maximum length of a schema name.
- Include a schema name that is left justified and conforms to the rules for forming an ordinary identifier or delimited identifier. If the identifier is delimited, it must not be empty or contain only blanks.
- Not contain SESSION_USER, USER, or DEFAULT.

DEFAULT

Specifies that CURRENT SCHEMA is to be set to its initial value, as if it had never been explicitly set during the application process. For information about the initial value of CURRENT SCHEMA, see [“CURRENT SCHEMA special register” on page 206](#).

Notes for SET SCHEMA

Considerations for keywords:

There is a difference between specifying a single keyword (such as SESSION_USER or DEFAULT) as a single keyword or as a delimited identifier. To indicate that the current value of the SESSION_USER special register should be used for setting the current schema, specify SESSION_USER as a keyword. To indicate that the special register should be set to its default value, specify DEFAULT as a keyword. If SESSION_USER or DEFAULT is specified as a delimited identifier instead (for example, "SESSION_USER"), it is interpreted as a schema name of that value ("SESSION_USER").

Transaction considerations:

The SET SCHEMA statement is not a committable operation. ROLLBACK has no effect on CURRENT SCHEMA.

Usage of the assigned value:

The value of the CURRENT SCHEMA special register, as set by this statement, is used as the schema name in all dynamic SQL statements. The QUALIFIER bind option specifies the schema name for use as the qualifier for unqualified database object names in static SQL statements.

Impact on other special registers:

Setting the CURRENT SCHEMA special register does not affect any other special register. Therefore, the CURRENT SCHEMA is not included in the SQL path that is used to resolve the schema name for unqualified references to function, procedures and user-defined types in dynamic SQL statements. To include the current schema value in the SQL path, whenever the SET SCHEMA statement is issued, also issue the SET PATH statement including the schema name from the SET SCHEMA statement.

Examples for SET SCHEMA

Example 1: The following statement sets the CURRENT SCHEMA special register.

```
EXEC SQL SET SCHEMA RICK;
```

Example 2: The following example retrieves the current value of the CURRENT SCHEMA special register into the host variable called CURSCHEMA.

```
EXEC SQL SELECT CURRENT SCHEMA INTO :CURSCHEMA
FROM SYSIBM.SYSDUMMY1;
```

The value of the host variable is RICK.

Example 3: Assume that the following statements are issued:

```
SET CURRENT SQLID = 'USRT001';
SET CURRENT SCHEMA = 'USRT002';
```

At this point, the two special registers contain different values. Any subsequent CREATE statements will use USRT002 as the implicit qualifier, but the owner of the newly created objects is USRT001.

Example 4: Assume that the value of CURRENT SCHEMA is 'Jane' and that the default value of the PATH special register was established using that value (that is, the value of PATH is "SYSIBM", "SYSFUN", "SYSPROC", "SYSIBMADM", "JANE"). Change the value of the CURRENT SCHEMA special register to 'John'.

```
SET CURRENT SCHEMA = 'JOHN';
```

To change the SQL path to use the updated CURRENT SCHEMA value of "JOHN", issue a SET PATH statement to change the value of the PATH special register to specify "JOHN" as the first schema to check:

```
SET PATH = 'JOHN', CURRENT PATH;
```

Alternatively, a commit would cause PATH to be re-initialized. Otherwise, the path remains "SYSIBM", "SYSFUN", "SYSPROC", "SYSIBMADM", "JANE"), which might cause unqualified object names to resolve to "JANE" when you want them to resolve to "JOHN".

SET SESSION TIME ZONE statement

The SET SESSION TIME ZONE statement assigns a value to the SESSION TIME ZONE special register.

Invocation for SET SESSION TIME ZONE

This statement can be embedded in an application program or issued interactively. It is an executable statement that can be dynamically prepared.

Authorization for SET SESSION TIME ZONE

None required.

Syntax for SET SESSION TIME ZONE

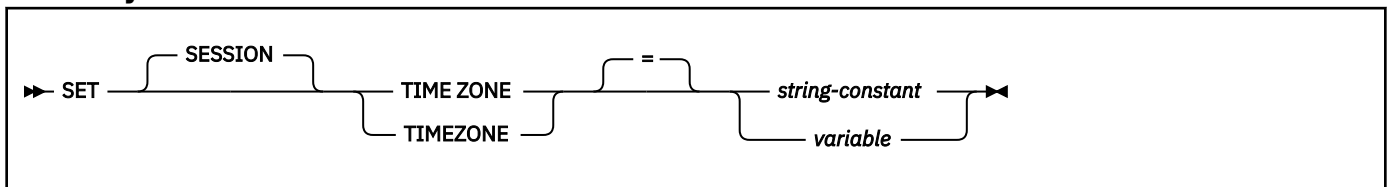

Description for SET SESSION TIME ZONE

string-constant

Identifies a time zone with a value of the form ' $\pm th:tm$ ', where *th* represents the time zone hour between -12 and +14, and *tm* represents the time zone minutes in the range 0–59, with values ranging from -12:59 to +14:00.

variable

Specifies a variable that contains a time zone. The variable must be a CHAR or VARCHAR variable that is not followed by an indicator variable. The variable must not be the null value. The value must be left justified and be of the form ' $\pm th:tm$ ', where *th* represents the time zone hour between -12 and +14, and *tm* represents the time zone minutes in the range 0–59, with values ranging from -12:59 to +14:00.

Notes for SET SESSION TIME ZONE

Impact on other special registers:

Setting the SESSION TIME ZONE special register does not affect the CURRENT TIMEZONE special register.

Syntax alternatives:

SESSIONTIMEZONE can be specified as an alternative to SESSION TIME ZONE or TIME ZONE.

Example for SET SESSION TIME ZONE

Set the SESSION TIME ZONE as -8:00:

```
SET SESSION TIME ZONE = '-8:00';
```

Related reference

[SESSION TIME ZONE special register](#)

The SESSION TIME ZONE special register specifies a value that identifies the time zone of the application process.

SIGNAL statement

The SIGNAL statement is used to signal an error. It causes an error to be returned with the specified SQLSTATE and error description.

Syntax

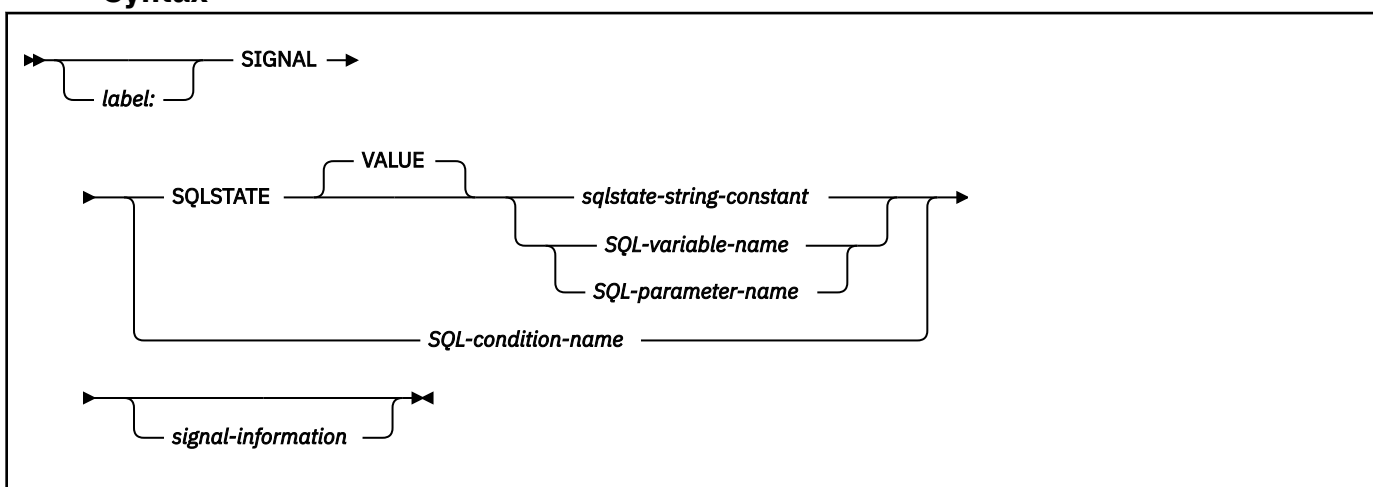

signal-information:

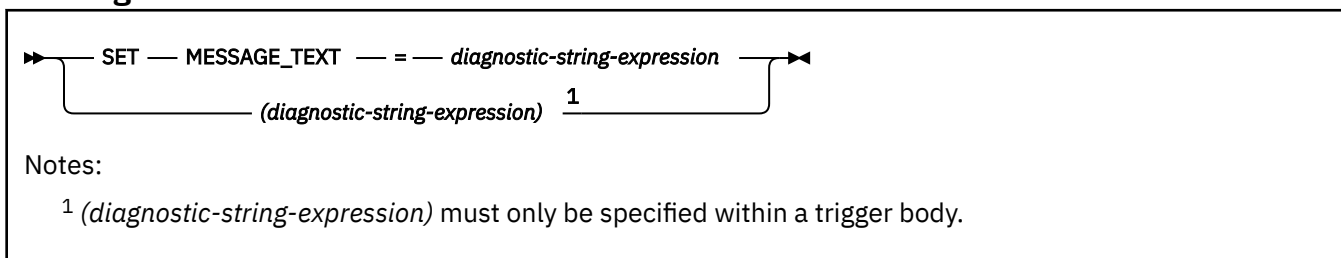

Description

label

Specifies the label for the SIGNAL statement. A label name cannot be the same as the routine name, advanced trigger name, or another label within the same scope. For additional information, see [“References to SQL labels”](#) on page 2210.

SQLSTATE VALUE

Specifies the SQLSTATE that will be returned. Any valid SQLSTATE value can be used. It must be a character string constant with exactly five characters that follow the rules for SQLSTATES:

- Each character must be from the set of digits ('0' through '9') or non-accented upper case letter ('A' through 'Z').

- The SQLSTATE class (the first two characters) cannot be '00' because it represents successful completion.

In the context of a MERGE statement, the following rules also apply:

- The SQLSTATE class (first two characters) cannot be '01' or '02', because these are not error classes.
- If the SQLSTATE class starts with the numbers '0' through '6' or the letters 'A' through 'H', the subclass (the last three characters) must start with a letter in the range of 'I' through 'Z'.
- If the SQLSTATE class starts with the numbers '7', '8', '9', or the letters 'I' through 'Z', the subclass can be any of '0' through '9' or 'A' through 'Z'.

If the SQLSTATE does not conform to these rules, an error occurs.

sqlstate-string-constant

A character string constant with an actual length of five bytes that is a valid SQLSTATE value.

SQL-variable-name or SQL-parameter-name

Specifies an SQL variable or SQL parameter that contains a valid SQLSTATE value.

SQL-variable-name

Specifies an SQL variable that is declared within the *compound-statement* that contains the SIGNAL statement, or within a compound statement in which that compound statement is nested. *SQL-variable-name* must be defined as a CHAR or VARCHAR data type with an actual length of five bytes, must not be null, and must contain a valid SQLSTATE value.

SQL-parameter-name

Specifies an SQL parameter that is defined for the routine and contains the SQLSTATE value. The SQL parameter must be defined as a CHAR or VARCHAR data type with an actual length of five bytes, must not be null, and must contain a valid SQLSTATE value.

SQL-condition-name

Specifies the name of the condition that will be returned. The *SQL-condition-name* must be declared within the compound statement that contains the SIGNAL statement, or within a compound statement in which that compound statement is nested.

SET MESSAGE_TEXT

Specifies a string that describes the error or warning. The string is returned in the SQLERRMC field of the SQLCA or with the GET DIAGNOSTICS statement.

diagnostic-string-expression

An expression with a data type of CHAR or VARCHAR that returns a character string of up to 1000 bytes that describes the error or warning condition. For information on how to obtain the complete message text, see [“GET DIAGNOSTICS statement” on page 1949](#).

(diagnostic-string-expression)

An expression with a data type of CHAR or VARCHAR that returns a character string of up to 1000 bytes that describes the error or warning condition. For information on how to obtain the complete message text, see [“GET DIAGNOSTICS statement” on page 1949](#).

This syntax variation is only provided within the scope of a CREATE TRIGGER statement for compatibility with previous versions of Db2. To conform with the ANS and ISO standards, this form should not be used.

Notes

While any valid SQLSTATE value can be used in the SIGNAL statement, programmers should define new SQLSTATES based on ranges reserved for applications. This practice prevents the unintentional use of an SQLSTATE value that might be defined by the database manager in a future release.

If the SQLSTATE or condition indicates that an exception is signaled:

- If a condition handler exists in the same compound statement as the SIGNAL statement, and the compound statement contains a condition handler for SQLEXCEPTION or the specified SQLSTATE or condition, the exception is handled and control is transferred to that condition handler.

- If the compound statement is nested and the outer level compound statement has a condition handler for `SQLWARNING` or the specified `SQLSTATE` or condition, the exception is handled and control is transferred to that condition handler.
- Otherwise, the exception is not handled and control is immediately returned to the end of the compound statement.

If the `SQLSTATE` or condition indicates that a warning or not found condition is signaled:

- If a condition handler exists in the same compound statement as the `SIGNAL` statement, and the compound statement contains a condition handler for `SQLWARNING`, `NOT FOUND`, or the specified `SQLSTATE` or condition, the warning or not found condition is handled and control is transferred to that condition handler.
- If the compound statement is nested and an outer level compound statement contains a condition handler for `SQLWARNING`, `NOT FOUND`, or the specified `SQLSTATE` or condition, the warning or not found condition is handled and control is transferred to that condition handler.
- Otherwise, the warning or not found condition is not handled and processing continues with the next statement.

Considerations for the diagnostics area: The `SIGNAL` statement starts with a clear diagnostics area and sets the `RETURNED_SQLSTATE` to reflect the specified `SQLSTATE` or *condition-name*. If message text is specified, the `MESSAGE_TEXT` item of the condition area is assigned the specified value. `DB2_RETURNED_SQLCODE` is set to +438 or -438 corresponding to the specified `SQLSTATE` or *condition-name*.

Examples

- The following example shows an SQL procedure for an order system that signals an application error when a customer number is not known to the application. The `ORDERS` table includes a foreign key to the `CUSTOMER` table, requiring that the `CUSTNO` exist before an order can be inserted.

```
CREATE PROCEDURE SUBMIT_ORDER
    (IN ONUM INTEGER, IN CNUM INTEGER,
     IN PNUM INTEGER, IN QNUM INTEGER)
LANGUAGE SQL
SPECIFIC SUBMIT_ORDER
MODIFIES SQL DATA
BEGIN
    DECLARE EXIT HANDLER FOR SQLSTATE VALUE '23503'
        SIGNAL SQLSTATE '75002'
            SET MESSAGE_TEXT = 'Customer number is not known';
    INSERT INTO ORDERS (ORDERNO, CUSTNO, PARTNO, QUANTITY)
        VALUES (ONUM, CNUM, PNUM, QNUM);
END
```

- The following example shows a trigger for an order system that allows orders to be recorded in an `ORDERS` table (`ORDERNO`, `CUSTNO`, `PARTNO`, `QUANTITY`) only if there is sufficient stock in the `PARTS` tables. When there is insufficient stock for an order, `SQLSTATE '75001'` is returned along with an appropriate error description.

```
CREATE TRIGGER CK_AVAIL
NO CASCADE BEFORE INSERT ON ORDERS
REFERENCING NEW AS NEW_ORDER
FOR EACH ROW MODE DB2SQL
WHEN (NEW_ORDER.QUANTITY > (SELECT ON_HAND FROM PARTS
                             WHERE NEW_ORDER.PARTNO = PARTS.PARTNO))
    BEGIN ATOMIC
        SIGNAL SQLSTATE '75001' ('Insufficient stock for order');
    END
```

Related concepts

[SQL procedural language \(SQL PL\)](#)

TRANSFER OWNERSHIP statement

The TRANSFER OWNERSHIP statement transfers the ownership of a database or system object from one owner to another. The new owner can be an authorization ID or a role.

Invocation for TRANSFER OWNERSHIP

This statement can be embedded in an application program or issued interactively. It is an executable statement that can be dynamically prepared only if DYNAMICRULES RUN behavior is in effect. For more information, see [“Authorization IDs and dynamic SQL”](#) on page 94.

Authorization for TRANSFER OWNERSHIP

Privilege set: If the statement is embedded in an application program, the privilege set is the privileges that are held by the owner of the package. If the owner of the package is a role, the role must hold the privileges for the privilege set.

If the statement is dynamically prepared, the privilege set is the privileges that are held by the SQL authorization ID of the process unless the process is within a trusted context and the ROLE AS OBJECT OWNER AND QUALIFIER clause is specified. If ROLE AS OBJECT OWNER is in effect, the role must hold the privileges for the privilege set.

The privilege set must include at least one of the following privileges:

- Ownership of the object
- SECADM authority

Explicit SECADM authority is always required regardless of the SEPARATE_SECURITY subsystem parameter setting. For more information, see [Separating the SYSADM authority \(Managing Security\)](#). If the Access Control Authorization exit is active, Db2 calls the exit to check for the SECADM authority. Only the SECADM authority is checked regardless of the SEPARATE_SECURITY system parameter value.

Syntax for TRANSFER OWNERSHIP

►► TRANSFER OWNERSHIP OF object TO new-owner REVOKE PRIVILEGES ◄◄

object:

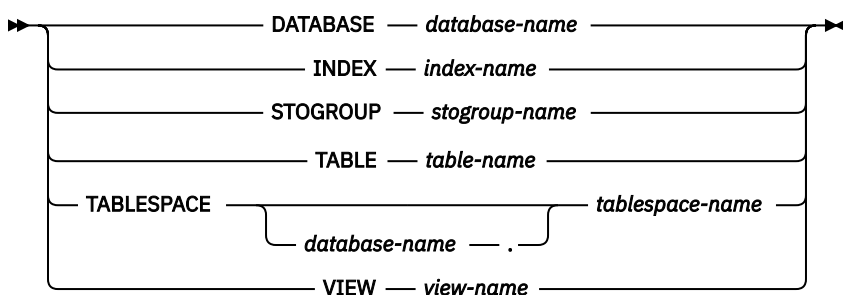

new-owner:

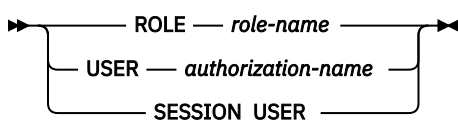

Description for TRANSFER OWNERSHIP

DATABASE *database-name*

Identifies the database for ownership transfer. The database must exist on the current server. The name of the database must not identify DSNDB01, DSNDB04, DSNDB06, or any implicitly created database owned by SYSIBM. When the ownership of the database is transferred, the CREATOR and CREATORTYPE values for the database in SYSIBM.SYSDATABASE are updated with the authorization ID or role and the type of the new owner. Transferring the ownership of a database does not transfer the ownership of any other object in the database that was created by the current owner.

INDEX *index-name*

Identifies the index for ownership transfer. The index must exist on the current server. The index must not be defined on a catalog table, a directory table or a declared temporary table. When the ownership of the index is transferred, the OWNER and OWNERTYPE values for the index in SYSIBM.SYSINDEXES are updated with the authorization ID or role and the type of the new owner.

STOGROUP *stogroup-name*

Identifies the storage group for ownership transfer. The storage group must exist the current server. When the ownership of the storage group is transferred, the CREATOR and CREATORTYPE values for the group in SYSIBM.SYSSTOGROUP are updated with the authorization ID or role and the type of the new owner.

TABLE *table-name*

Identifies the table for ownership transfer. The table must exist on the current server, and it must not be a view, a catalog table, a directory table, a table with the SECURITY LABEL column, or a table that is implicitly created for an XML column. If the table is referenced by a qualified name, the name can be a two-part or three-part name. If a three-part name is used, the first part must match the value of the field Db2 LOCATION NAME on installation panel DSNTIPR at the current server. If the current server is not the local Db2, this name is not necessarily the name in the CURRENT SERVER special register.

If *table-name* is an alias for a table and *alias-name* is specified, ownership of the table is transferred to the new owner and the alias is unchanged.

When the ownership of a table is transferred, the ownership of any implicitly created object, such as a table space, auxiliary table, auxiliary table space, XML table, XML table space, or index, is also transferred if the table and the implicitly created object have the same owner. In addition, the ownership of an explicitly created auxiliary table or auxiliary table space is also transferred if the table and the explicitly created object have the same owner.

When the ownership of the table is transferred, the OWNER and OWNERTYPE values for the table in SYSIBM.SYSTABLES are updated with the authorization ID or role and the type of the new owner.

TABLESPACE *tablespace-name*

Identifies the table space for ownership transfer. The table space must exist on the current server, but it must not have been implicitly created for an XML column. The database must not be DSNDB01, DSNDB06, or DSNDB04. Omitting a database name implicitly specifies DSNDB04. When the ownership of the table space is transferred, the CREATOR and CREATORTYPE values for the table space in SYSIBM.SYSTABLESPACE are updated with the authorization ID or role and the type of the new owner.

VIEW *view-name*

Identifies the view for ownership transfer. The view must exist on the current server. If the view is referenced by a qualified name, the name can be a two-part or three-part name. If a three-part name is used, the first part must match the value of the field Db2 LOCATION NAME on installation panel DSNTIPR at the current server. If the current server is not the local Db2, this name is not necessarily the name in the CURRENT SERVER special register.

If *view-name* is an alias for a view and *alias-name* is specified, ownership of the view is transferred to the new owner and the alias is unchanged.

When the ownership of the view is transferred, the OWNER and OWNERTYPE values for the view in SYSIBM.SYSTABLES and SYSIBM.SYSVIEWS are updated with the authorization ID or role and the type of the new owner.

TO

Specifies the authorization ID or the role to which the ownership of an object is transferred.

ROLE *role-name*

Specifies the role to which the ownership of an object is transferred. The new role must exist on the current server.

USER *authorization-name*

Specifies the authorization ID to which the ownership of the object is transferred.

SESSION_USER

Specifies that the value of the SESSION_USER special register is used as the authorization ID to which the ownership of an object is transferred.

REVOKE PRIVILEGES

Specifies that the current owner no longer has any implicit privileges on the object after the transfer is complete. The corresponding authorization cache entries for the current owner are cleared.

If any packages or objects are dependent on an implicit privilege that the current owner has on the object of the statement, a TRANSFER OWNERSHIP statement fails because existing privileges are revoked. For the current owner to maintain access to those dependent packages, authorization must be explicitly granted to the current owner from another source before the TRANSFER OWNERSHIP statement is executed. For example, assume that a user created a package that references one of their tables. The user implicitly has the SELECT privilege on tables they created. To transfer that table to another owner and still be able to use the package, the user must be explicitly granted the SELECT privilege on the table before the TRANSFER OWNERSHIP statement is executed.

Notes for TRANSFER OWNERSHIP

- The TRANSFER OWNERSHIP statement does not change the schema of the transferred object.
- The ownership of any system object whose OWNER is SYSIBM or whose schema begins with SYS cannot be transferred.
- The new owner is automatically granted the same privileges that the current owner holds on the object at the time of the object's creation. For example, if the current owner has the DBADM authority on the database when the database was created, the new owner is automatically granted the DBADM authority on the database.
- An authorization ID with the SECADM authority cannot transfer the ownership of an object to itself.
- Db2 issues a warning when the current owner of an object attempts to transfer the ownership to itself.
- If the current owner of an object is a role, the dependency record for that role in SYSIBM.SYSOBJROLEDEP is deleted when the object ownership is transferred. If the new owner is a role, the dependency record for that role is added to SYSIBM.SYSOBJROLEDEP.
- A SECADM or ACCESSCTRL authority can use the REVOKE statement with the BY clause to revoke any privilege that is granted on the object by the current owner.
- When the ownership of an object is transferred, the new owner must have the same set of privileges on the object as specified in the dependency record of the object. The privileges are required for the object to continue to exist. The new owner does not need additional privileges that are required for creating the object. Consider the following examples.
 - If a view has SELECT and INSERT dependencies on an underlying table and when the ownership is transferred, the new owner of the view must be granted the same SELECT and INSERT privileges. If the dependencies are SELECT WITH GRANT OPTION and INSERT WITH GRANT OPTION, the new owner must be granted the same SELECT WITH GRANT OPTION and INSERT WITH GRANT OPTION privileges.
 - If a view has a dependency on a routine and when the ownership of the view is transferred, the new owner must be granted the EXECUTE privilege on the dependent routine.
 - If a table has a distinct type column and when the ownership of the table is transferred, the new owner must be granted the USAGE privilege on the distinct type.

Examples for TRANSFER OWNERSHIP

Example 1: Transfer the ownership of database DBCC001 to user USRT001 and remove the current owner's privileges on the database:

```
TRANSFER OWNERSHIP OF DATABASE DBCC001 TO USER USRT001
REVOKE PRIVILEGES;
```

Example 2: Transfer the ownership of database DBCC002 to role OWNRROLE and remove the current owner's privileges on the database:

```
TRANSFER OWNERSHIP OF DATABASE DBCC002 TO ROLE OWNRROLE
REVOKE PRIVILEGES;
```

Example 3: Transfer the ownership of database DBCC003 to session user SESSION_USER and remove the current owner's privileges on the database:

```
TRANSFER OWNERSHIP OF DATABASE DBCC003 TO SESSION_USER
REVOKE PRIVILEGES;
```

Example 4: Transfer the ownership of table EMPLOYEE.DEPT to role TBOWNR_ROLE and remove the current owner's privileges on the table:

```
TRANSFER OWNERSHIP OF TABLE EMPLOYEE.DEPT TO ROLE TBOWNR_ROLE
REVOKE PRIVILEGES;
```

Example 5: Transfer the ownership of index EMPLOYEE.SALARYIX to user IXOWNER and remove the current owner's privileges on the index:

```
TRANSFER OWNERSHIP OF INDEX EMPLOYEE.SALARYIX TO USER IXOWNER
REVOKE PRIVILEGES;
```

TRUNCATE statement

The Db2 TRUNCATE statement deletes all rows for either base tables or declared global temporary tables. The base table can be in a simple table space, a segmented (non-UTS) table space, a partitioned (non-UTS) table space, or a universal table space. If the table contains LOB or XML columns, the corresponding table spaces and indexes are also truncated.

Invocation for TRUNCATE

This statement can be embedded in an application program or issued interactively. It is an executable statement that can be dynamically prepared.

Authorization for TRUNCATE

The privilege set that is defined below must include at least one of the following privileges:

- The DELETE privilege for the table
- Ownership of the table
- DBADM authority for the database
- DATAACCESS authority
- SYSADM authority

If the database is implicitly created, the database privileges must be on the implicit database or on DSNDBO4.

If the IGNORE DELETE TRIGGERS option is in effect, the privilege set must include at least one of the following privileges:

- The ALTER privilege for the table
- Ownership of the table
- DBADM authority for the database
- System DBADM authority
- SYSADM authority

If row access control is activated for the table, the privilege set must include at least one of the following privileges or authorities:

- Ownership of the table
- DBADM authority
- SYSADM authority
- SYSCTRL authority
- System DBADM authority

Privilege set: If the statement is embedded in an application program, the privilege set is the privileges that are held by the owner of the plan or package. If the statement is dynamically prepared, the privilege set is determined by the DYNAMICRULES behavior in effect (run, bind, define, or invoke) and is summarized in “Dynamic preparation and execution” on page 1088. (For more details on these behaviors, including a list of the DYNAMICRULES bind option values that determine them, see “Authorization IDs and dynamic SQL” on page 94.)

Syntax for TRUNCATE

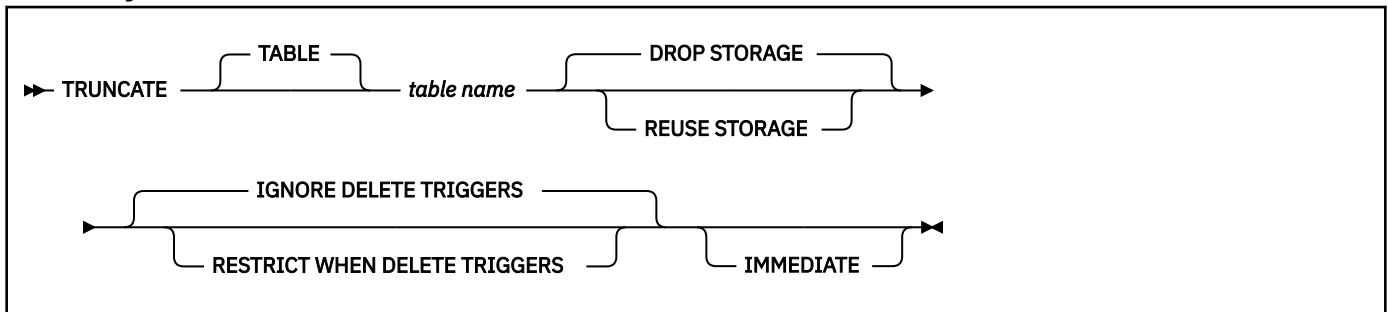

Description for TRUNCATE

table-name

Identifies the table that is to be truncated. The name must identify a table that exists at the current server. The name must not identify the following objects:

- a view
- an auxiliary table
- an XML table
- a catalog table
- a system-period temporal table
- an accelerator-only table

If *table-name* is a base table of a table space, all tables that are defined under the table will also be truncated (for example: auxiliary LOB table spaces and XML table spaces), and all of its associated indexes will also be truncated.

DROP STORAGE or REUSE STORAGE

Specifies whether to drop or reuse the existing storage that is allocated for the table.

DROP STORAGE

Specifies that all storage that is allocated for the table is released and made available for use for the same table or any other table that resides in the table space. The scope of DROP STORAGE

is always at the table space level and the deallocated space is always available for reuse by all tables in the table space.

DROP STORAGE is the default.

REUSE STORAGE

Specifies that all storage that is allocated for the table will be emptied, but will continue to be allocated for the table. REUSE STORAGE is ignored for a table in a simple table space and the statement is processed as if DROP STORAGE is specified.

RESTRICT WHEN DELETE TRIGGERS or IGNORE DELETE TRIGGERS

Specifies what to do when delete triggers are defined on the table.

RESTRICT WHEN DELETE TRIGGERS

Specifies that an error is returned if delete triggers are defined on the table.

IGNORE DELETE TRIGGERS

Specifies that any delete triggers that are defined for the table are not activated by the truncate operation. Additional authorization is required for this option; see [“Authorization for TRUNCATE”](#) on page 2175.

IGNORE DELETE TRIGGERS is the default.

IMMEDIATE

Specifies that the truncate operation is processed immediately and cannot be undone. If the IMMEDIATE option is specified, the table must not contain any uncommitted updates. In the case of a table in a multi-table table space, if there are any uncommitted updates to any table in the table space, the truncate operation will fail. Also, if there are any uncommitted CREATE, ALTER or DROP statements for any table in the table space, the truncate operation will fail.

The truncated table is immediately available for use in the same unit of work. Although a ROLLBACK statement is allowed to execute after a TRUNCATE statement, the truncate operation is not undone, and the table remains in a truncated state. For example, if another data change operation is done on the table after the TRUNCATE IMMEDIATE statement and then the ROLLBACK statement is executed, the truncate operation will not be undone, but all other data change operations are undone.

If IMMEDIATE is not specified, a ROLLBACK statement can undo the truncate operation.

The IMMEDIATE option can be specified for a table in a segmented (non-UTS) table space or a universal table space which allows deallocated spaces to be reclaimed immediately for subsequent insert operations in the same unit of work without committing the truncate operation.

Notes for TRUNCATE

Rules and restrictions:

The truncate operation cannot be executed if the table is a parent table in an enforced referential constraint. The Db2 subsystem issues an error when it detects the existence of rule violations. Therefore, if the referential integrity constraint exists, the TRUNCATE statement will be restricted regardless of whether the child table contains rows.

The TRUNCATE statement cannot be used if the table is a system-maintained temporal table.

If the TRUNCATE statement is used on a tables where any of the following conditions is true, the truncate operation will perform in a similar way to a mass delete operation:

- Tables with Change Data Capture (CDC) attribute

The Db2 subsystem allows a table with the CDC-enabled attribute to be truncated without imposing any new restrictions.

- Tables with multi-level security

If the table contains a column that is defined as a security label, the truncate operation needs to examine each row to determine if the security label of the authorization ID or role has the authority to delete that row. However, if the primary authorization ID or role has write-down privilege, verification of each row in the table is not necessary.

- Tables with a VALIDPROC attribute

If a VALIDPROC is defined for the table, the truncate operation needs to verify the validity of each row in the table.

TRUNCATE and table spaces that are not logged:

The TRUNCATE TABLE statement can be used to remove a table space from the logical page list and to reset recover-pending status. When the table space is a segmented (non-UTS) table space or universal table space, the table is the only table in the table space, and the table does not have a VALIDPROC, referential constraints, delete triggers, or a SECURITY LABEL column, use the TRUNCATE TABLE statement to empty the table and the table space will be removed from the LPL and recover-pending status will be reset.

Truncating rows from a table with activated row permissions or column access control:

Row permissions and column access control is not enforced for the TRUNCATE statement.

Examples for TRUNCATE

Example 1: Empty an unused inventory table regardless of any existing triggers and return its allocated space.

```
TRUNCATE TABLE INVENTORY
      DROP STORAGE
      IGNORE DELETE TRIGGERS;
```

Example 2: Empty an unused inventory table regardless of any existing delete triggers but preserve its allocated space for later reuse.

```
TRUNCATE TABLE INVENTORY
      REUSE STORAGE
      IGNORE DELETE TRIGGERS;
```

Example 3: Empty an unused inventory table permanently (a ROLLBACK statement cannot undo the truncate operation when the IMMEDIATE option is specified) regardless of any existing delete triggers and preserve its allocated space for immediate use.

```
TRUNCATE TABLE INVENTORY
      REUSE STORAGE
      IGNORE DELETE TRIGGERS
      IMMEDIATE;
```

UPDATE statement

The UPDATE statement updates the values of specified columns in rows of a table or view. Updating a row of a view updates a row of its base table if no INSTEAD OF UPDATE trigger is defined for this view. If such a trigger is defined, the trigger is activated instead.

The table or view can exist at the current server or at any Db2 subsystem with which the current server can establish a connection.

There are two forms of this statement:

- The *searched* UPDATE form is used to update one or more rows optionally determined by a search condition.
- The *positioned* UPDATE form specifies that one or more rows corresponding to the current cursor position are to be updated.

Invocation for UPDATE

This statement can be embedded in an application program or issued interactively. A positioned UPDATE can be embedded in an application program. Both forms are executable statements that can be dynamically prepared.

Authorization for UPDATE

Authority requirements depend on whether the object identified in the statement is a user-defined table, a catalog table for which updates are allowed, or a view, and whether SQL standard rules are in effect:

When a user-defined table is identified: The privilege set must include at least one of the following:

- DATAACCESS authority
- The UPDATE privilege on the table
- The UPDATE privilege on each column to be updated
- Ownership of the table
- DBADM authority on the database that contains the table
- SYSADM authority

If the database is implicitly created, the database privileges must be on the implicit database or on DSNDBO4.

When a catalog table is identified: The privilege set must include at least one of the following:

- ACCESSCTRL authority
- DATAACCESS authority
- The UPDATE privilege on each column to be updated
- DBADM authority on the catalog database
- Installation SYSOPR authority
- SYSCTRL authority
- SYSADM authority
- SYSADM authority
- System DBADM authority

When a view is identified: The privilege set must include at least one of the following:

- DATAACCESS authority
- SYSADM authority
- UPDATE privilege on the view
- UPDATE privilege on each column to be updated

If the *expression* in the *assignment-clause* contains a reference to a column of the table or view, or if the *search-condition* in a searched UPDATE contains a reference to a column of the table or view, the privilege set must include at least one of the following:

- The SELECT privilege on the table or view
- Ownership of the table or view
- DBADM authority on the database that contains the table, if the target is a table and that table that is not a catalog table
- DATAACCESS
- SYSADM authority

When FOR PORTION OF BUSINESS_TIME is specified: The privilege set must include at least one of the following:

- The UPDATE privilege on the columns of the BUSINESS_TIME period
- The UPDATE privilege on the table
- Ownership of the table or view
- DBADM authority on the database that contains the table, if the target is a table and that table that is not a catalog table

- DATAACCESS
- SYSADM authority

If the *search-condition* in a searched UPDATE includes a subquery, or if the *assignment-clause* includes a *scalar-fullselect* or a *row-fullselect*, see [“Authorization for queries” on page 1007](#) for an explanation of the authorization required.

The owner of a view, unlike the owner of a table, might not have UPDATE authority on the view (or might have UPDATE authority without being able to grant it to others). The nature of the view itself can preclude its use for UPDATE. For more information, see the discussion of authority in [“CREATE VIEW statement” on page 1812](#).

FL 509 If the statement attempts to update a row in the SYSIBM.SYSAUDITPOLICIES catalog table that is subject to a tamper-proof audit policy, additional RACF authorization is required. During statement execution, the primary authorization ID or one of the groups associated with the primary authorization ID must be authorized to access the tamper-proof audit policy profile in RACF. For more information on the authorization rules, see [Db2 audit policies \(Managing Security\)](#).

Privilege set: If the statement is embedded in an application program, the privilege set is the privileges that are held by the owner of the plan or package. If the statement is dynamically prepared, the privilege set is determined by the DYNAMICRULES behavior in effect (run, bind, define, or invoke) and is summarized in [“Dynamic preparation and execution” on page 1088](#). (For more information on these behaviors, including a list of the DYNAMICRULES bind option values that determine them, see [“Authorization IDs and dynamic SQL” on page 94](#)).

searched update:

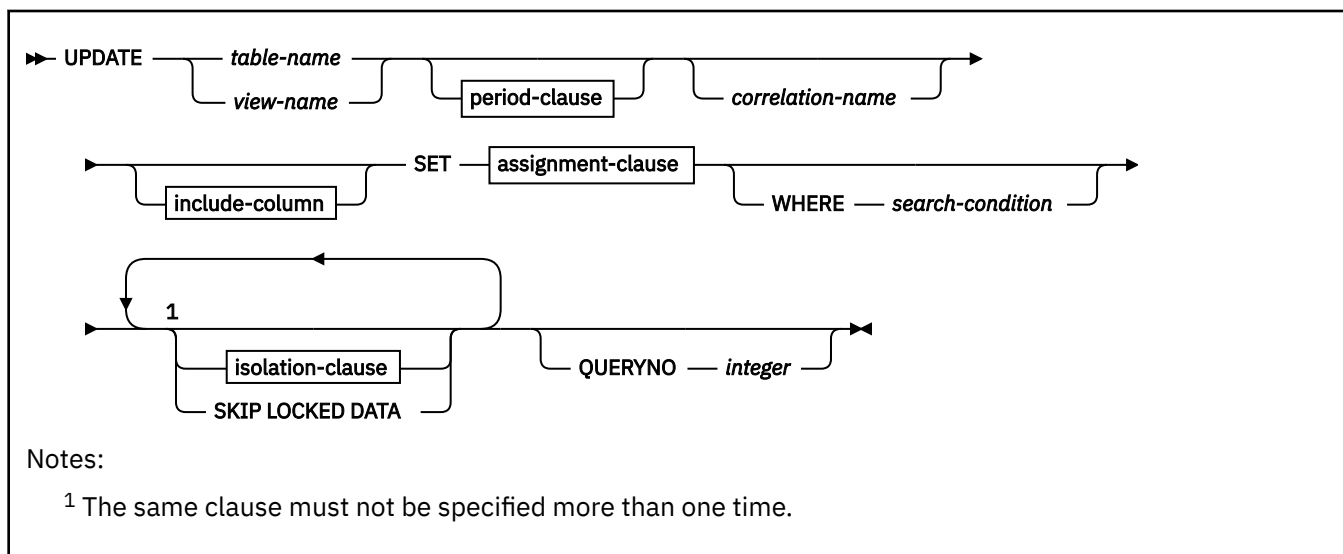

positioned update:

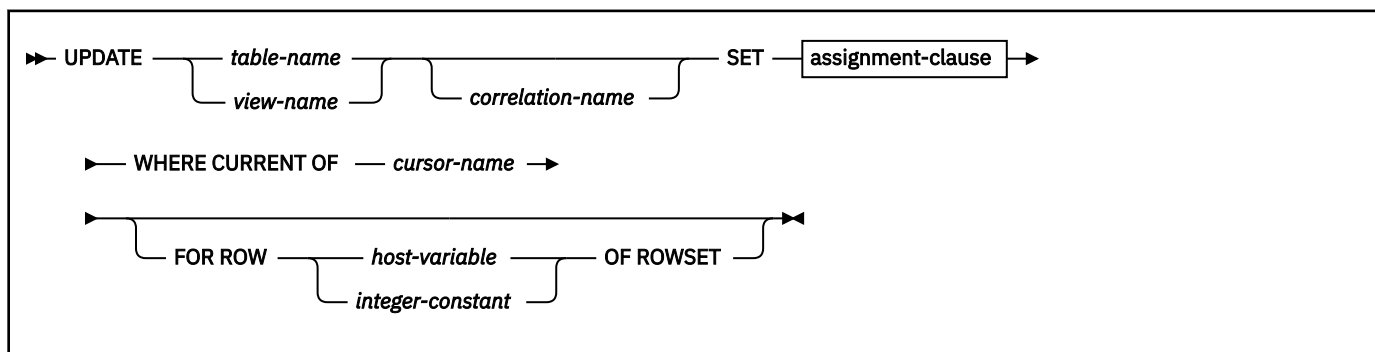

period-clause:

►► FOR PORTION OF BUSINESS_TIME — FROM — *value1* — TO — *value2* — ◄◄
BETWEEN — *value1* — AND — *value2* — ◄◄

include-column:

►► INCLUDE — (— *column-name* — data-type —) — ◄◄

data-type:

►► built-in-type — ◄◄
distinct-type — ◄◄

built-in-type:

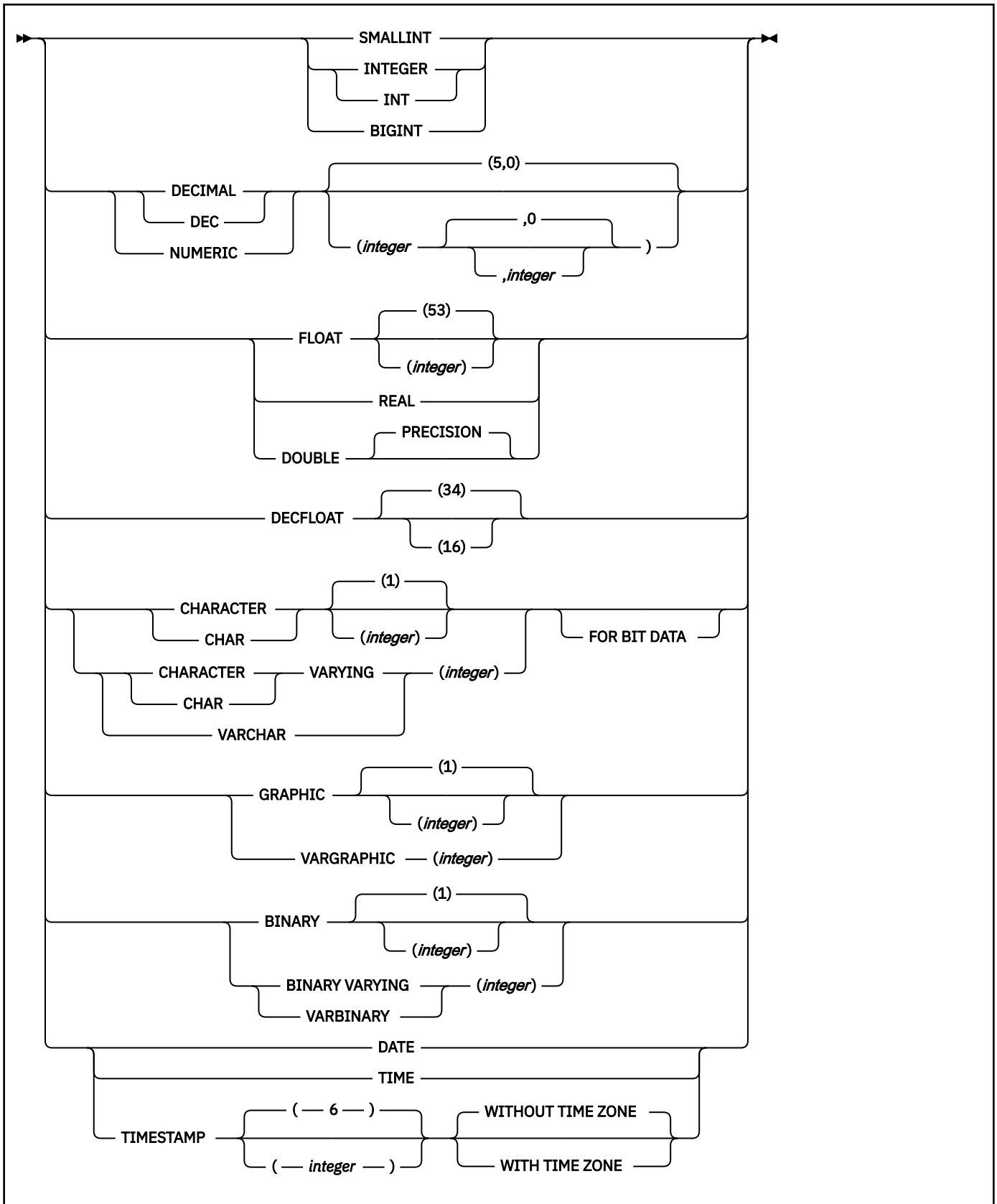

assignment clause:

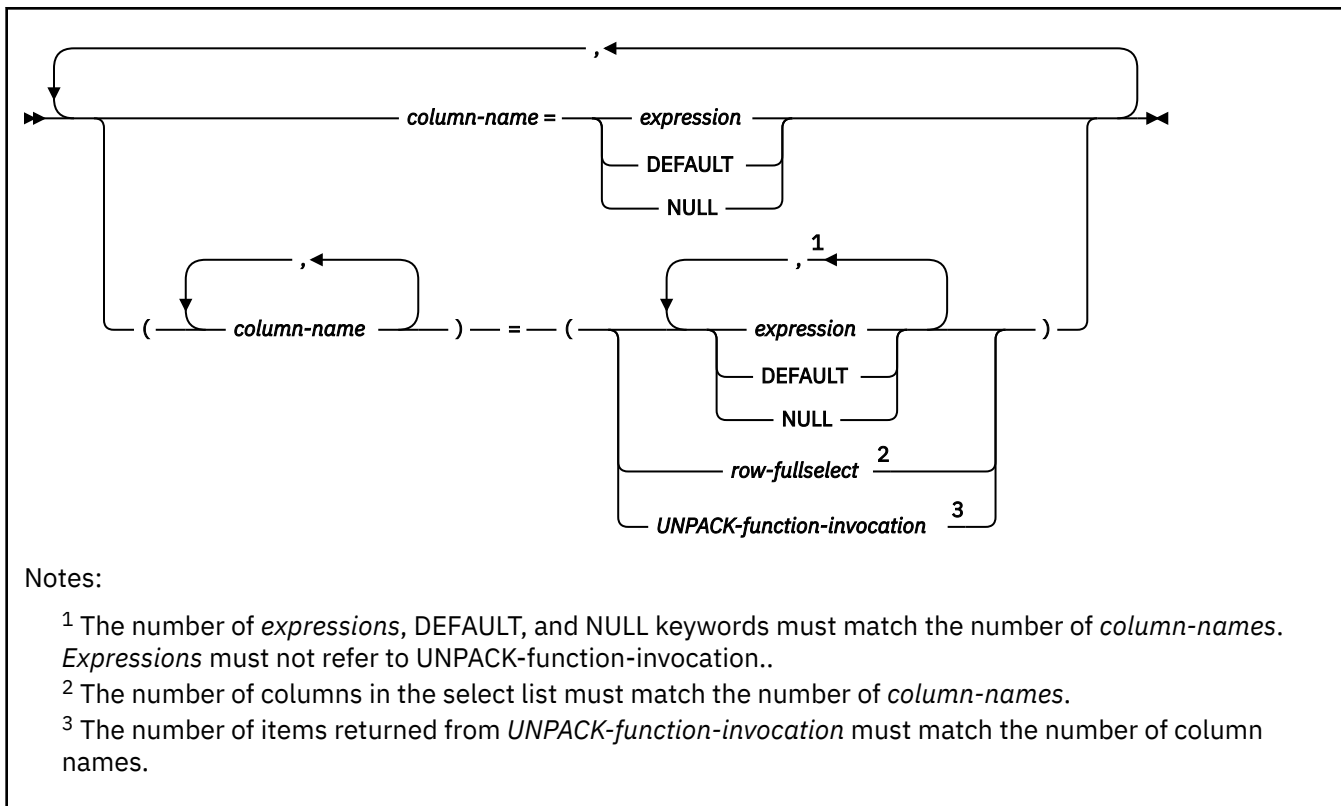

isolation-clause:



Description for UPDATE

table-name or view-name

Identifies the object of the UPDATE statement. The name must identify a table or view that exists at the Db2 subsystem that is identified by the implicitly or explicitly specified location name. The name must not identify one of the following tables:

- An auxiliary table
- A created temporary table or a view of a created temporary table
- A catalog table with no updatable columns or a view of a catalog table with no updatable columns
- A directory table
- A read-only view that has no INSTEAD OF trigger defined for its update operations. (For a description of a read-only view, see [“CREATE VIEW statement”](#) on page 1812.)
- A system-maintained materialized query table
- A table that is implicitly created for an XML column
- An archive-enabled table if any of the following conditions are true:
 - The SYSIBMADM.MOVE_TO_ARCHIVE global variable is set to Y.
 - The SYSIBMADM.GET_ARCHIVE global variable is set to Y, the ARCHIVESENSITIVE bind option is set to YES, and the operation is a positioned update.

In an IMS or CICS application, the Db2 subsystem that contains the identified table or view must be a remote server that supports two-phase commit.

A catalog table or a view of a catalog table can be identified if every column identified in the SET clause is an updatable column. If a column of a catalog table is updatable, its description in [Appendix H, "Db2 catalog tables,"](#) on page 2333 indicates that the column can be updated. If the object table is SYSIBM.SYSSTRINGS, any column other than IBMREQD can be updated, but the rows that are selected for update must be rows that are provided by the user (the value of the IBMREQD column is N) and only certain values can be specified as explained in [How an entry in SYSIBM.SYSSTRINGS works with character conversion \(Db2 Installation and Migration\)](#).

period-clause

Specifies that a period clause applies to the target of the update operation. The same period name must not be specified more than one time. If the target of the update operation is a view:

- The FROM clause of the outer fullselect of the view definition must include a reference, directly or indirectly, to an application-period temporal table.
- The result table of the outer fullselect of the view definition must include, explicitly or implicitly, the start and end columns of the BUSINESS_TIME period.
- An INSTEAD OF trigger must not be defined for the view.

FOR PORTION OF BUSINESS_TIME

Specifies that the update only applies to row values for the portion of the BUSINESS_TIME period in the row that is specified by the period clause. BUSINESS_TIME must be a period that is defined on the table.

FOR PORTION OF BUSINESS_TIME must not be specified if the value of the CURRENT TEMPORAL BUSINESS_TIME special register is not NULL when the BUSTIMESENSITIVE bind option is set to YES.

FROM *value1* TO *value2*

Specifies that the update applies to rows for the period that is specified from *value1* to *value2*. No rows are updated if *value1* is greater than or equal to *value2* or if *value1* or *value2* is the null value.

This clause must not be specified for an inclusive-inclusive period.

For the period condition that is specified with FROM *value1* TO *value2*, the period that is specified with *period-name* in a row of the target update:

- Overlaps the beginning of the specified period if the value of the begin column is less than *value1* and the value of the end column is greater than *value1*.
- Overlaps the end of the specified period if the value of the end column is greater than or equal to *value2* and the value of the begin column is less than *value2*.
- Is fully contained within the specified period if the value for the begin column is greater than or equal to *value1* and the value for the end column is less than or equal to *value2*.
- Is not contained in the period if both columns of *period-name* are less than *value1* or greater than or equal to *value2*.
- Is partially contained in the specified period if the period in the row overlaps the beginning of the specified period or the end of the specified period, but not both.
- Fully overlaps the specified period if the period in the row overlaps both the beginning and the end of the specified period.

If the period, *period-name* in a row is not contained in the specified period, the row is not updated. Otherwise, the update is applied based on the specification of PORTION OF and how the values in the columns of *period-name* overlap the specified period as follows:

- If the period, *period-name* in a row is fully contained within the specified period, the row is updated and the values of the begin column and end column of *period-name* are unchanged.
- If the period, *period-name* in a row is partially contained in the specified period and overlaps the beginning of the specified period:

- The row is updated. In the updated row, the value of the begin column is set to *value1* and the value of the end column is the original value of the end column.
- An additional row is inserted using the original values from the row, except that the end column is set to *value1*, and new values are used for other generated columns.
- If the period, *period-name* in a row is partially contained in the specified period and overlaps the end of the specified period:
 - The row is updated. In the updated row, the value of the begin column is the original value of the begin column and the end column is set to *value2*.
 - An additional row is inserted using the original values from the row, except that the begin column is set to *value2*, and new values are used for other generated columns.
- If the period, *period-name* in a row fully overlaps the specified period:
 - The row is updated. In the updated row, the value of the begin column is set to *value1* and the value of the end column is set to *value2*.
 - An additional row is inserted using the original values from the row, except that the end column is set to *value1*, a column defined as DATA CHANGE OPERATION is set to 'I', and new values are used for other generated columns.
 - An additional row is inserted using the original values from the row, except that the begin column is set to *value2*, a column defined as DATA CHANGE OPERATION is set to 'I', and new values are used for other generated columns.

Any existing update triggers are activated for the updated rows and any existing insert triggers are activated for rows that are implicitly inserted.

BETWEEN *value1* AND *value2*

Specifies that the update operation applies to rows for the period that is specified from *value1* up to and including *value2*. No rows are updated if *value1* is greater than *value2*, or if *value1* or *value2* is the null value. This clause must not be specified for an inclusive-exclusive period.

For the period clause that is specified with BETWEEN *value1* AND *value2*, period *period-name* in a row in the target of the update operation:

- Overlaps the beginning of the specified period if the value of the begin column is less than *value1* and the value of the end column is greater than *value1*.
- Overlaps the end of the specified period if the value of the end column is greater than or equal to *value2* and the value of the begin column is less than *value2*.
- Is fully contained within the specified period if the value for the begin column for *period-name* in the row is greater than or equal to *value1* and the value for the corresponding end column in the row is less than or equal to *value2*.
- Is partially contained in the specified period if the row overlaps the beginning of the specified period or the end of the specified period, but not both.
- Fully overlaps the specified period if the period in the row overlaps the beginning of the specified period and overlaps the end of the specified period.
- Is not contained in the period if both columns of *period-name* are less than *value1* or greater than *value2*.

If the period *period-name* in a row is not contained in the specified period, the row is not updated. Otherwise, the update operation is based on the following items:

- The specification of the PORTION OF clause.
- How the values in the columns of *period-name* overlap the specified period.
- *spu* (smallest period unit), which depends on the data type of the columns of the period as follows:
 - For a period containing DATE columns, *spu* is 1 day.
 - For a period containing TIMESTAMP(6) columns, *spu* is 1 microsecond.

Based on those items, the update operation is applied as follows:

- If the period *period-name* in a row is fully contained within the specified period, the row is updated and the values of the begin column and end column of *period-name* are unchanged.
- If the period *period-name* in a row is partially contained in the specified period and overlaps the beginning of the specified period:
 - The row is updated. In the updated row the value of the begin column is set to *value1* and the value of the end column is the original value of the end column.
 - A row is inserted using the original values from the row, except that the end column is set to *value1* - spu, and new values are used for other generated columns.
- If the period *period-name* in a row is partially contained in the specified period and overlaps the end of the specified period:
 - The row is updated. In the updated row the value of the begin column is the original value of the begin column and the end column is set to *value2*
 - A row is inserted using the original values from the row, except that the begin column is set to *value2* + spu, and new values are used for other generated columns.
- If the period *period-name* in a row fully overlaps the specified period:
 - The row is updated. In the updated row the value of the begin column is set to *value1* and the value of the end column is set to *value2*.
 - A row is inserted using the original values from the row, except that the end column is set to *value1* - spu, a column defined as DATA CHANGE OPERATION is set to 'I', and new values are used for other generated columns.
 - An additional row is inserted using the original values from the row, except that the begin column is set to *value2* + spu, a column defined as DATA CHANGE OPERATION is set to 'I', and new values are used for other generated columns.

value1, value2

Specifies expressions that return a value of a built-in data type. The result of each expression must be comparable to the data type of the columns of the specified period. See the comparison rules described in [“Assignment and comparison” on page 143](#). Each expression can contain any of the following supported operands:

- A constant
- A special register
- A variable
- An array element specification
- A built-in scalar function whose arguments are supported operands
- A CAST specification where the cast operand is a supported operand
- An expression that uses arithmetic operators and operands

Each expression must not have a timestamp precision that is greater than the precision of the columns for the period.

If the begin and end columns of the period are defined as `TIMESTAMP WITHOUT TIME ZONE`, each expression must not return a value of a timestamp with a time zone.

A period clause for a view must not contain an untyped parameter marker.

correlation-name

Can be used within *search-condition* or *assignment-clause* to designate the table or view. (For an explanation of *correlation-name*, see [“Correlation names” on page 220](#).)

include-column

Specifies a set of columns that are included, along with the columns of *table-name* or *view-name*, in the result table of the UPDATE statement when it is nested in the FROM clause of the outer fullselect that is used in a subselect, SELECT statement, or in a SELECT INTO statement. The included columns

are appended to the end of the list of columns that is identified by *table-name* or *view-name*. If no value is assigned to a column that is specified by an *include-column*, a NULL value is returned for that column.

INCLUDE

Introduces a list of columns that are to be included in the result table of the UPDATE statement. The included columns are only available if the UPDATE statement is nested in the FROM clause of a SELECT statement or a SELECT INTO statement.

column-name

Specifies the name for a column of the result table of the UPDATE statement that is not the same name as another included column nor a column in the table or view that is specified in *table-name* or *view-name*.

data-type

Specifies the data type of the included column. The included columns are nullable.

built-in-type

Specifies a built-in data type. See [“CREATE TABLE statement” on page 1650](#) for a description of each built-in type.

The CCSID 1208 and CCSID 1200 clauses must not be specified for an INCLUDE column.

distinct-type

Specifies a distinct type. Any length, precision, or scale attributes for the column are those of the source type of the distinct type as specified by using the CREATE TYPE statement.

SET

Introduces the assignment of values to column names.

assignment-clause

If *row-fullselect* is specified, the number of columns in the result of *row-fullselect* must match the number of *column-names* that are specified. If *row-fullselect* is not specified, the number of expressions, and NULL and DEFAULT keywords must match the number of *column-names* that are specified.

column-name

Identifies a column that is to be updated. *column-name* must identify a column of the specified table or view. If extended indicators are not enabled, that column must be an updatable column. The column must not identify a generated column or a view column where the column is derived from a scalar function, constant, or expression. *column-name* can also identify an INCLUDE column that must not be qualified. The same column name must not be specified more than once.

A column that is defined as part of a BUSINESS_TIME period must not be specified if the UPDATE statement contains a *period-clause*.

Assignments to included columns are only processed when the UPDATE statement is nested in the FROM clause of a SELECT statement or a SELECT INTO statement. There must be at least one assignment clause that specifies a *column-name* that is not an INCLUDE column. The null value is returned for an included column that is not set by using an explicit SET clause.

For a positioned update, allowable column names can be further restricted to those in a certain list. This list appears in the FOR UPDATE clause of the SELECT statement for the associated cursor. The clause can be omitted by using the conditions that are described in [“Positioned updates of columns” on page 326](#).

A view column that is derived from the same column as another column of the view can be updated, but both columns cannot be updated in the same UPDATE statement.

expression

Indicates the new value of the column. The *expression* is any expression of the type described in [“Expressions” on page 245](#). It must not include an aggregate function.

A *column-name* in an expression must identify a column of the table or view. For each row that is updated, the value of the column in the expression is the value of the column in the row before the row is updated.

If *expression* is a single host variable, the host variable can include an indicator with an extended indicator value. If extended indicators are enabled, and an expression in the assignment clause is not a single host variable, the extended indicator values of DEFAULT and UNASSIGNED must not be used.

A CAST specification can be used if either of the following is true:

- The target column is defined as nullable.
- The target column is defined as NOT NULL with a non-null default, the source of the CAST specification is a single host variable, and the data attributes (data type, length, precision, and scale) of the host variable are the same as the result of the cast specification.

DEFAULT

Specifies that the default value is used based on how the corresponding column is defined in the table. DEFAULT must not be specified for a ROWID column. The value that is assigned depends on how the column is defined.

- If the column is a generated expression, the column value will be generated by the Db2 subsystem based on the result of the expression.
- If the column is an identity column, row change timestamp column, row-begin column, row-end column, or transaction-start-ID column, the Db2 subsystem will generate a new value.
- If the column is defined using the WITH DEFAULT clause, the value is set to the default that is defined for the column.
- If the column is defined without specifying the WITH DEFAULT clause, the GENERATED clause, or the NOT NULL clause, the value is NULL.
- If the column is specified in the INCLUDE column list, the column value is set to null.

DEFAULT must be specified for a column that was defined as GENERATED ALWAYS. A valid value can be specified for a column that was defined as GENERATED BY DEFAULT.

If the column is defined using the NOT NULL clause and the GENERATED clause is not used, or the WITH DEFAULT clause is not used, the DEFAULT keyword cannot be specified for that column.

NULL

Specifies the null value as the new value of the column. Specify NULL only for nullable columns.

row-fullselect

Specifies a fullselect that returns a single row. The column values are assigned to each of the corresponding *column-names*. If the fullselect returns no rows, the null value is assigned to each column; an error occurs if any column to be updated is not nullable. An error also occurs if there is more than one row in the result.

For a positioned update, if the table or view that is the object of the UPDATE statement is used in the fullselect, a column from the instance of the table or view in the fullselect cannot be the same as *column-name*, a column being updated.

If the fullselect refers to columns to be updated, the value of such a column in the fullselect is the value of the column in the row before the row is updated.

UNPACK-function-invocation

Specifies an invocation of the UNPACK built-in function. The number of fields that are returned by the UNPACK function invocation must be the same as the number of *column-names*.

WHERE

Specifies the rows to be updated. You can omit the clause, give a search condition, or specify a cursor. If you omit the clause, all rows of the table or view are updated.

search-condition

Specifies any search condition described in [Chapter 2, “Language elements in SQL,” on page 75](#). Each *column-name* in the search condition, other than in a subquery, must identify a column of the table or view.

The *search-condition* is applied to each row of the table or view and the updated rows are those for which the result of the *search-condition* is true. If the unique key or primary key is a parent key, the constraints are effectively checked at the end of the operation.

If the search condition contains a subquery, the subquery can be thought of as being executed each time the search condition is applied to a row, and the results used in applying the search condition. In actuality, a subquery with no correlated references is executed just once, whereas it is possible that a subquery with a correlated reference must be executed once for each row.

WHERE CURRENT OF *cursor-name*

Identifies the cursor to be used in the update operation. *cursor-name* must identify a declared cursor as explained in the description of the DECLARE CURSOR statement in [“DECLARE CURSOR statement” on page 1819](#). If the UPDATE statement is embedded in a program, the DECLARE CURSOR statement must include *select-statement* rather than *statement-name*.

The object of the UPDATE statement must also be identified in the FROM clause of the SELECT statement of the cursor. The columns to be updated can be identified in the FOR UPDATE clause of that SELECT statement though they do not have to be identified. If the columns are not specified, the columns that can be updated include all the updatable columns of the table or view that is identified in the first FROM clause of the fullselect.

The result table of the cursor must not be read-only. For an explanation of read-only result tables, see [Read-only cursors](#). Note that the object of the UPDATE statement must not be identified as the object of the subquery in the WHERE clause of the SELECT statement of the cursor.

When the UPDATE statement is executed, the cursor must be open and positioned on a row or rowset of the result table.

- If the cursor is positioned on a single row, that row is the one updated.
- If the cursor is positioned on a rowset, all rows corresponding to the rows of the current rowset are updated.

A positioned UPDATE must not be specified for a cursor that references a view on which an instead of update trigger is defined, even if the view is an updatable view.

FOR ROW *n* OF ROWSET

Specifies which row of the current rowset is to be updated. The corresponding row of the rowset is updated, and the cursor remains positioned on the current rowset.

host-variable or *integer-constant* is assigned to an integral value *k*. If *host-variable* is specified, it must be an exact numeric type with scale zero, must not include an indicator variable, and *k* must be in the range 1–32767.

The cursor must be positioned on a rowset, and the specified value must be a valid value for the set of rows most recently retrieved for the cursor. If the specified row cannot be updated, an error is returned. It is possible that the specified row is within the bounds of the rowset most recently requested, but the current rowset contains less than the number of rows that were implicitly or explicitly requested when that rowset was established.

If this clause is not specified, the cursor position determines the rows that will be affected. If the cursor is positioned on a single row, that row is the one updated. In the case where the most recent FETCH statement returned multiple rows of data (but not as a rowset), this position would be on the last row of data that was returned. If the cursor is positioned on a rowset, all rows corresponding to the current rowset are updated. The cursor position remains unchanged.

It is possible for another application process to update a row in the base table of the SELECT statement so that the specified row of the cursor no longer has a corresponding row in the base table. An attempt to update such a row results in an error.

isolation-clause

Specifies the isolation level used when locating the rows to be updated by the statement.

WITH

Introduces the isolation level, which may be one of the following:

RR

Repeatable read

RS

Read stability

CS

Cursor stability

The default isolation level of the statement is the isolation level of the package or plan in which the statement is bound, with the package isolation taking precedence over the plan isolation. When a package isolation is not specified, the plan isolation is the default.

SKIP LOCKED DATA

Specifies that rows are skipped when incompatible locks are held on the row by other transactions. These rows can belong to any accessed table that is specified in the statement. `SKIP LOCKED DATA` can be used only when isolation `CS` or `RS` is in effect and applies only to row level or page level locks.

`SKIP LOCKED DATA` can be specified only in the searched `UPDATE` statement (or the searched update operation of a `MERGE` statement). `SKIP LOCKED DATA` is ignored if it is specified when the isolation level that is in effect is repeatable read (`WITH RR`) or uncommitted read (`WITH UR`). The default isolation level of the statement depends on the isolation level of the package or plan with which the statement is bound, with the package isolation taking precedence over the plan isolation. When a package isolation is not specified, the plan isolation is the default.

QUERYNO integer

Specifies the number to be used for this SQL statement in `EXPLAIN` output and trace records. The number is used for the `QUERYNO` column of the plan table for the rows that contain information about this SQL statement. This number is also used in the `QUERYNO` column of the `SYSIBM.SYSSTMT` and `SYSIBM.SYSPACKSTMT` catalog tables.

If the clause is omitted, the number associated with the SQL statement is the statement number assigned during precompilation. Thus, if the application program is changed and then precompiled, that statement number might change.

Using the `QUERYNO` clause to assign unique numbers to the SQL statements in a program is helpful:

- For simplifying the use of optimization hints for access path selection
- For correlating SQL statement text with `EXPLAIN` output in the plan table

For more information about enabling and using optimization hints, see [Influencing access path selection \(Db2 Performance\)](#)

For information on accessing the plan table, see [Investigating SQL performance by using EXPLAIN \(Db2 Performance\)](#).

Notes for UPDATE**Update rules:**

Update values must satisfy the following rules. If they do not, or if other errors occur during the execution of the `UPDATE` statement, no rows are updated and the position of the cursors are not changed.

- *Assignment.* Update values are assigned to columns using the assignment rules described in [Chapter 2, “Language elements in SQL,” on page 75.](#)
- *Validity.* Updates must obey the following rules. If they do not, or if any other errors occur during the execution of the `UPDATE` statement, no rows are updated.

- *Fullselects*: The row-fullselect and expressions that contain a *scalar-fullselect* must return no more than one row.
- *Unique constraints and unique indexes*: If the identified table (or base table of the identified view) has any unique indexes or unique constraints, each row that is updated in the table must conform to the limitations that are imposed by those indexes and constraints.

All uniqueness checks are effectively made at the end of the statement. In the case of a multi-row update, this validation occurs after all the rows are updated.

- *Check constraints*: If the identified table (or base table of the identified view) has any check constraints, each check constraint must be true or unknown for each row that is updated in the table.

All checks constraints are effectively validated at the end of the statement. In the case of a multi-row update, this validation occurs after all the rows are updated.

- *Views and the WITH CHECK OPTION*. For views defined with WITH CHECK OPTION, an updated row must conform to the definition of the view. If the view you name is dependent on other views whose definitions include WITH CHECK OPTION, the updated rows must also conform to the definitions of those views. For an explanation of the rules governing this situation, see [“CREATE VIEW statement” on page 1812](#).

For views that are not defined with WITH CHECK OPTION, you can change the rows so that they no longer conform to the definition of the view. Such rows are updated in the base table of the view and no longer appear in the view.

- *Field and validation procedures*. The updated rows must conform to any constraints imposed by any field or validation procedures on the identified table (or on the base table of the identified view).
- *Referential constraints*. The value of the parent key in a parent row must not be changed. If the update value produces a foreign key that is nonnull, the foreign key must be equal to some value of the parent key of the parent table of the relationship.

All referential constraints are effectively checked at the end of the statement. In the case of a multi-row update, this validation occurs after all the rows are updated.

- *Indexes with VARBINARY columns*. If the identified table has an index on a VARBINARY column or a column that is a distinct type that is based on VARBINARY data type, that index column cannot specify the DESC attribute. To use the SQL data change operation on the identified table, either drop the index or alter the data type of the column to BINARY and then rebuild the index.
- *Triggers*. An UPDATE statement might cause triggers to activate. A trigger might cause other statements to be executed or raise error conditions based on the update values. If an UPDATE statement for a view causes an instead of trigger to activate, validity, referential integrity, and check constraints are checked against the data changes that are performed in the trigger and not against the view that causes the trigger to activate or its underlying base tables.

Number of rows updated:

Normally, after an UPDATE statement completes execution, the value of SQLERRD(3) in the SQLCA is the number of rows updated. (For a complete description of the SQLCA, including exceptions to the preceding sentence, see [Appendix F, “SQL communication area \(SQLCA\),” on page 2303](#).)

Nesting user-defined functions or stored procedures:

An UPDATE statement can implicitly or explicitly refer to user-defined functions or stored procedures. This is known as *nesting* of SQL statements. A user-defined function or stored procedure that is nested within the UPDATE must not access the table being updated.

Locking:

Unless appropriate locks already exist, one or more exclusive locks are acquired by the execution of a successful update operation. Until a commit or rollback operation releases the locks, only the application process that performed the insert can access the updated row. If LOBs are not updated, application processes that are running with uncommitted read can also access the updated row. The locks can also prevent other application processes from performing operations on the table. However, application processes that are running with uncommitted read can access locked pages and rows.

Locks are not acquired on declared temporary tables.

Datetime representation when using datetime registers:

As explained under [Datetime special registers](#), when two or more datetime registers are implicitly or explicitly specified in a single SQL statement, they represent the same point in time. This is also true when multiple rows are updated.

Rules for positioned UPDATE with a SENSITIVE STATIC scrollable cursor:

When a SENSITIVE STATIC scrollable cursor has been declared, the following rules apply:

- *Update attempt of delete holes.* If, with a positioned update against a SENSITIVE STATIC scrollable cursor, an attempt is made to update a row that has been identified as a delete hole, an error occurs.
- *Update operations.* Positioned update operations with SENSITIVE STATIC scrollable cursors perform as follows:
 1. The SELECT list items in the target row of the base table of the cursor are compared with the values in the corresponding row of the result table (that is, the result table must still agree with the base table). If the values are not identical, then the update operation is rejected, and an error occurs. The operation may be attempted again after a successful FETCH SENSITIVE has occurred for the target row.
 2. The WHERE clause of the SELECT statement is re-evaluated to determine whether the current values in the base table still satisfy the search criteria. The values in the SELECT list are compared to determine that these values have not changed. If the WHERE clause evaluates as true, and the values in the SELECT have not changed, the update operation is allowed to proceed. Otherwise, the update operation is rejected, an error occurs, and an *update hole* appears in the cursor.
- *Update of update holes.* Update holes are not permanent. It is possible for another process, or a searched update in the same process, to update an update hole row so that it is no longer an update hole. Update holes become visible with a FETCH SENSITIVE for positioned updates and positioned deletes.
- *Result table.* After the base table is updated, the row is re-evaluated and updated in the temporary result table. At this time, it is possible that the positioned update changed the data such that the row does not qualify the search condition, in which case the row is marked as an update hole for subsequent FETCH operations.

Referencing columns that will be updated:

If a cursor uses FETCH statements to retrieve columns that will be updated later, specify FOR UPDATE OF when you select the columns. Then specify WHERE CURRENT OF in the subsequent UPDATE or DELETE statements. These clauses prevent Db2 from selecting access through an index on the columns that are being updated, which might otherwise cause Db2 to read the same row more than once.

For more information, see [Updating previously retrieved data \(Db2 Application programming and SQL\)](#).

Updating rows in a table with multilevel security:

When you update rows in a table with multilevel security, Db2 compares the security label of the user (the primary authorization ID) to the security label of the row. The update proceeds according to the following rules:

- If the security label of the user and the security label of the row are equivalent, the row is updated and the value of the security label is determined by whether the user has write-down privilege:
 - If the user has write-down privilege or write-down control is not enabled, the user can set the security label of the row to any valid security label. The value that is specified for the security label column must be assignable to a column that is defined as CHAR(8) FOR SBCS DATA NOT NULL.
 - If the user does not have write-down privilege and write-down control is enabled, the security label of the row is set to the value of the security label of the user.

- If the security label of the user dominates the security label of the row, the result of the UPDATE statement is determined by whether the user has write-down privilege:
 - If the user has write-down privilege or write-down control is not enabled, the row is updated and the user can set the security label of the row to any valid security label.
 - If the user does not have write-down privilege and write-down control is enabled, the row is not updated.
- If the security label of the row dominates the security label of the user, the row is not updated.

Updating rows in a table for which row or column access control is enforced:

When an UPDATE statement is issued for a table for which row or column access control is enforced, the rules specified in the enabled row permissions or column masks determine whether the row can be updated. Typically those rules are based on the authorization ID or role of the process. The following describes how enabled row permissions and column masks are used during UPDATE:

- Row permissions are used to identify the set of rows to be updated.

When multiple enabled row permissions are defined for a table, a row access control search condition is derived by application of the logical OR operator to the search condition in each enabled permission. This row access control search condition is applied to the table to determine which rows are accessible to the authorization ID or role of the UPDATE statement. If the WHERE clause is specified in the UPDATE statement, the user-specified predicates are applied on the accessible rows to determine the rows to be updated. If there is no WHERE clause, the accessible rows are the rows to be updated.

Column masks are not applicable in this step.

If the table is not enforced by row access control, the WHERE clause determines the rows to be updated, otherwise all rows in the table are to be updated.

- If there are rows to be updated, the following rules determine whether those rows can be updated:
 - For every column to be updated, the new value of the column must not be affected by enabled column masks whose columns are referenced when deriving the new value.

When a column is referenced while deriving the values of a new row, if the column has an enabled column mask, the masked value is used to derive the new values. If the object table is also column access control activated, the column mask applied to derive the new values must ensure the evaluation of the access control rules defined in the column mask resolves the column to itself, not to a constant or an expression. If the column mask does not mask the column to itself, the new value cannot be used for update and an error is returned at run time.

- If the rows are updatable, and there is a BEFORE UPDATE trigger for the table, the trigger is activated.

Within the trigger actions, the new values for update might be modified in transition variables. When the final values are returned from the trigger, the new values are used for the update.

- The rows that are to be updated must conform to the enabled row permissions:

For each row that is to be updated, the old values are replaced with the new values that were specified in the UPDATE statement. A row that conforms to the enabled row permissions is a row that, if updated, can be retrieved using the derived row access control search condition.

- If the rows are updatable, and there is an AFTER UPDATE trigger for the table, the trigger is activated.

The above rules are not applicable to the included columns. The included columns are subject to the rules for the select list because they are not the columns of the object table of the UPDATE statement.

Extended indicators usage:

When extended indicators are enabled, indicator values other than positive values and 0 (zero) through -7 must not be specified. The DEFAULT and UNASSIGNED extended indicator values must not appear in contexts where they are not supported.

Extended indicators:

Specifying an indicator value with the extended indicator value of UNASSIGNED has the same effect as if the column had not been specified in the statement. Assigning an extended indicator value of DEFAULT assigns the default value to the column, and must only be specified for a column that is defined with a default value.

If a target column is not updatable, such as an identity column that is defined as GENERATED ALWAYS, it must be assigned the extended indicator value of UNASSIGNED.

An UPDATE statement must not specify the extended indicator value of UNASSIGNED for all target columns.

Extended indicators and update triggers:

If the indicator value for a target column is UNASSIGNED, that column is not considered to have been updated. That column is treated as if it had not been specified in the OF *column-name* list of any update trigger that is defined on the target table or view.

Extended indicators and deferred error checks:

When extended indicators are enabled, validation that would normally be done during statement preparation to recognize an insert into a non-updatable column is deferred until the statement is executed.

Considerations for a generated column:

A generated column that is defined as GENERATED ALWAYS should not be specified as the target of an assignment clause unless the value that is to be assigned is specified with the DEFAULT keyword or an extended indicator that specifies that a default value is to be assigned.

Considerations for a system-period temporal table:

When a row of a system-period temporal table is updated, Db2 updates the values of the row-begin and transaction-start-ID columns as follows:

- A row-begin column is assigned a value for the data type of the column. If the value of the SYSIBM.TEMPORAL_LOGICAL_TRANSACTION_TIME built-in global variable at the time of the update is null, the value is generated using a reading of the time-of-day clock during execution of the first data change statement in the unit of work that requires a value to be assigned to a row-begin column or transaction-start-ID column in a table, or a row in a system-period temporal table is deleted. Otherwise, the row-begin column is assigned the value of the SYSIBM.TEMPORAL_LOGICAL_TRANSACTION_TIME built-in global variable at the time of the insert.
- A transaction-start-ID column is assigned a unique timestamp value per unit of work or the null value. The null value is assigned to the transaction-start-ID column if the column is nullable. Otherwise, the value is generated by using the time-of-day clock during execution of the first data change statement in the unit of work that requires a value to be assigned to a row-begin column or transaction-start-ID column in a table. This also occurs when a row in a system-period temporal table is deleted. If multiple rows are updated within a single SQL unit of work, the values for the transaction-start-ID column are the same for all the rows and are unique from the values that are generated for the column for another unit of work.

If the UPDATE statement has a search condition that contains a correlated subquery that references historical rows (explicitly referencing the name of the history table or implicitly referenced through the use of a period specification in the FROM clause), the old version of the updated rows that are inserted as historical rows (into the history table) are potentially visible to update operations for the rows that are subsequently processed for the statement.

If the CURRENT TEMPORAL SYSTEM_TIME special register is set to a non-null value, the underlying target of the UPDATE statement cannot be a system-period temporal table. This restriction applies regardless of whether the system-period temporal table is directly or indirectly referenced.

Considerations for a history table:

When a row of a system-period temporal table is updated, a historical copy of the row is inserted into the corresponding history table and the end timestamp of the historical row is captured in the form of a system determined value that corresponds to the time of the data change operation. Db2 generates the value by using the time-of-day clock during the execution of the first data change statement in the transaction that requires a value to be assigned to a row-begin or transaction-start-

ID column in a table. This also occurs when a row in a system-period temporal table is deleted. If the value of the SYSIBM. TEMPORAL_LOGICAL_TRANSACTION_TIME built-in global variable at the time of the data change operation is null, the value is generated using a reading of the time-of-day clock during execution of the first data change statement in the unit of work that requires a value to be assigned to a row-begin column or transaction-start-ID column in a table, or a row in a system-period temporal table is deleted. Otherwise, the value is assigned from the SYSIBM.TEMPORAL_LOGICAL_TRANSACTION_TIME built-in global variable at the time of the data change operation.

Considerations for an application-period temporal table:

An UPDATE statement that contains a FOR PORTION OF BUSINESS_TIME clause for an application-period temporal table indicates the two points in time between which the specified updates are effective.

Suppose that FOR PORTION OF BUSINESS_TIME is specified, and the period value for a row is only partially contained in the period that is specified from *value1* up to *value2* or between *value1* and *value2*. (The period value for a row is specified by the values of the begin column and end column for the BUSINESS_TIME period.) In this case, the row is updated and one or two rows are automatically inserted to represent the portion of the row that is not changed. For each row that is automatically inserted as a result of an update operation on the table, new values are generated for each generated column in the application-period temporal table. If a generated column is defined as part of a unique or primary key, parent key in a referential constraint, or unique index, an automatic insert might violate a constraint or index. In this case, an error is returned.

When an application-period table is the target of an UPDATE statement and the value in effect for the CURRENT TEMPORAL BUSINESS_TIME special register is not the null value, Db2 adds the following additional predicates to the statement:

- inclusive-exclusive period:

```
bt_begin <= CURRENT TEMPORAL BUSINESS_TIME AND  
bt_end > CURRENT TEMPORAL BUSINESS_TIME
```

- inclusive-inclusive period:

```
bt_begin <= CURRENT TEMPORAL BUSINESS_TIME AND  
bt_end >= CURRENT TEMPORAL BUSINESS_TIME
```

In the preceding code, bt_begin and bt_end are the begin and end columns of the BUSINESS_TIME period of the target table of the UPDATE statement.

Archive-enabled tables:

A reference to an archive-enabled table as the target of the UPDATE statement does not affect rows in the associated archive table.

A data change statement must not reference an archive-enabled table when a system-period temporal table or application-period temporal table is also referenced.

Other SQL statements in the same unit of work:

The following statements cannot follow an UPDATE statement in the same unit of work:

- An ALTER TABLE statement that changes the data type of a column (ALTER COLUMN SET DATA TYPE)
- An ALTER INDEX statement that changes the padding attribute of an index with varying-length columns (PADDED to NOT PADDED or vice versa)
- A CREATE TABLE statement that creates an accelerator-only table.
- An INSERT, UPDATE, or DELETE statement that updates accelerator-only tables from a different accelerator.

Using UPDATE to reset AREO* status on a table:

An UPDATE statement will reset the AREO* state of a table if all conditions are true:

- The statement is a searched UPDATE statement. An UPDATE statement within a SELECT statement will not reset the AREO* state.
- The expression in the SET clause is not a *scalar-fullselect* or *row-fullselect*
- The update operation is against a table in a universal table space
- The table does not have row access control activated
- The SKIP LOCKED DATA clause is not specified
- The WHERE clause is not specified
- A resource unavailable condition is not encountered.

No error or warning SQLCODE is returned if a resource unavailable condition is encountered. Only a resource unavailable console message will be displayed.

A DISPLAY DATABASE command can be used to determine if AREO* is reset.

Examples for UPDATE

Example 1

Change employee 000190's telephone number to 3565 in DSN8C10.EMP.

```
UPDATE DSN8C10.EMP
SET PHONENO='3565'
WHERE EMPNO='000190';
```

Example 2

Give each member of department D11 a 100-dollar raise.

```
UPDATE DSN8C10.EMP
SET SALARY = SALARY + 100
WHERE WORKDEPT = 'D11';
```

Example 3

Employee 000250 is going on a leave of absence. Set the employee's pay values (SALARY, BONUS, and COMMISSION) to null.

```
UPDATE DSN8C10.EMP
SET SALARY = NULL, BONUS = NULL, COMM = NULL
WHERE EMPNO='000250';
```

Alternatively, the statement could also be written as follows:

```
UPDATE DSN8C10.EMP
SET (SALARY, BONUS, COMM) = (NULL, NULL, NULL)
WHERE EMPNO='000250';
```

Example 4

Assume that a column named PROJSIZE has been added to DSN8C10.EMP. The column records the number of projects for which the employee's department has responsibility. For each employee in department E21, update PROJSIZE with the number of projects for which the department is responsible.

```
UPDATE DSN8C10.EMP
SET PROJSIZE = (SELECT COUNT(*)
                FROM DSN8C10.PROJ
                WHERE DEPTNO = 'E21')
WHERE WORKDEPT = 'E21';
```

Example 5

Double the salary of the employee represented by the row on which the cursor C1 is positioned.

```
EXEC SQL UPDATE DSN8C10.EMP
SET SALARY = 2 * SALARY
WHERE CURRENT OF C1;
```

Example 6

Assume that employee table EMP1 was created with the following statement:

```
CREATE TABLE EMP1
(EMP_ROWID    ROWID GENERATED ALWAYS,
 EMPNO       CHAR(6),
 NAME        CHAR(30),
 SALARY      DECIMAL(9,2),
 PICTURE     BLOB(250K),
 RESUME      CLOB(32K));
```

Assume that host variable *HV_EMP_ROWID* contains the value of the ROWID column for employee with employee number '350000'. Using that ROWID value to identify the employee and user-defined function UPDATE_RESUME, increase the employee's salary by \$1000 and update that employee's resume.

```
EXEC SQL UPDATE EMP1
  SET SALARY = SALARY + 1000,
      RESUME = UPDATE_RESUME(:HV_RESUME)
 WHERE EMP_ROWID = :HV_EMP_ROWID;
```

Example 7

In employee table X, give each employee whose salary is below average a salary increase of 10%.

```
EXEC SQL UPDATE EMP X
  SET SALARY = 1.10 * SALARY
 WHERE SALARY < (SELECT AVG(SALARY) FROM EMP Y
 WHERE X.JOBCODE = Y.JOBCODE);
```

Example 8

Raise the salary of the employees in department 'E11' whose salary is below average to the average salary.

```
EXEC SQL UPDATE EMP T1
  SET SALARY = (SELECT AVG(T2.SALARY) FROM EMP T2)
 WHERE WORKDEPT = 'E11' AND
      SALARY < (SELECT AVG(T3.SALARY) FROM EMP T3);
```

Example 9

Give the employees in department 'E11' a bonus equal to 10% of their salary.

```
EXEC SQL
  DECLARE C1 CURSOR FOR
  SELECT BONUS
  FROM DSN8710.EMP
  WHERE WORKDEPT = 'E12'
  FOR UPDATE OF BONUS;
EXEC SQL
  UPDATE DSN8710.EMP
  SET BONUS = ( SELECT .10 * SALARY FROM DSN8710.EMP Y
                WHERE EMPNO = Y.EMPNO )
  WHERE CURRENT OF C1;
```

Example 10

Assuming that cursor CS1 is positioned on a rowset consisting of 10 rows in table T1, update all 10 rows in the rowset.

```
EXEC SQL UPDATE T1 SET C1 = 5 WHERE CURRENT OF CS1;
```

Example 11

Assuming that cursor CS1 is positioned on a rowset consisting of 10 rows in table T1, update the fourth row of the rowset.

```
short ind1, ind2;
int n, updt_value;
stmt = 'UPDATE T1 SET C1 = ? WHERE CURRENT OF CS1 FOR ROW ? OF ROWSET'
```

```

ind1 = 0;
ind2 = 0;
n = 4;
updt_value = 5;
...
strcpy(my_sqlda.sqldaid,"SQLDA");

my_sqlda.sqln = 2;
my_sqlda.sqld = 2;

my_sqlda.sqlvar[0].sqltype = 497;
my_sqlda.sqlvar[0].sqllen = 4;
my_sqlda.sqlvar[0].sqldata = (int *) &updt_value;
my_sqlda.sqlvar[0].sqlind = (short *) &ind1;

my_sqlda.sqlvar[1].sqltype = 497;
my_sqlda.sqlvar[1].sqllen = 4;
my_sqlda.sqlvar[1].sqldata = (int *) &n;
my_sqlda.sqlvar[1].sqlind = (short *) &ind2;

EXEC SQL PREPARE S1 FROM :stmt;

EXEC SQL EXECUTE S1 USING DESCRIPTOR :my_sqlda;

```

Example 12

Assume that table POLICY exists and that it is defined with a single inclusive-exclusive period, BUSINESS_TIME. The table contains a row where column BK has a value of 'P138', column CLIENT has a value of 'C882', column TYPE has a value of 'PPO', and the period has value ('2013-01-01', '2020-12-31'). Update the portion of the row beginning from '2014-01-01' to set the TYPE column to 'HMO':

```

UPDATE POLICY
  FOR PORTION OF BUSINESS_TIME
  FROM '2014-01-01' TO '9999-12-31'
  SET TYPE='HMO'
  WHERE BK='P138', CLIENT='C882';

```

After the UPDATE statement is processed, the table contains 2 rows in place of the original row. One row with period value ('2013-01-01', '2014-01-01') represents a value of 'PPO' for the TYPE column (the value before the update) and the other row with period value ('2014-01-01', '2020-12-31') represents a value of 'HMO' for the TYPE column (that began with the UPDATE statement).

Example 13

Suppose that the INTARRAY and CHARARRAY array types, the INTA, CHARA, and SI variables, and the T1 table are defined as follows:

```

CREATE TYPE INTARRAY AS INTEGER ARRAY [6];
CREATE TYPE CHARARRAY AS CHAR(20) ARRAY [7];
CREATE VARIABLE INTA AS INTARRAY;
CREATE VARIABLE CHARA AS CHARARRAY;
CREATE VARIABLE SI INT;
CREATE TABLE T1 (COL1 CHAR(7), COL2 INT);

```

Assign values to CHARA, INTA, and SI.

```

SET CHARA = ARRAY [ 'a', 'b', 'c' ];
SET INTA = ARRAY [ 1, 2, 3, 4, 5 ];
SET SI = 1;

```

Insert a row into table T1, and then update the row values using values from the CHARA and INTA arrays, which are indexed by the value of variable SI.

```

INSERT INTO T1 VALUES ('abc', 10);
UPDATE T1
  SET COL1 = CHARA[SI],
      COL2 = INTA[SI];

```

In the table row, COL1 now contains 'a', and COL2 contains 1.

Set the value of column COL2 for all rows to the cardinality of array INTA.

```
UPDATE T1
SET COL2 = CARDINALITY(INTA);
```

In the table row, COL2 now contains 5.

Example 14

Assume that table POLICY exists and that it is defined with a single inclusive-inclusive period, BUSINESS_TIME. The table contains a row where column BK has a value of 'P138', column CLIENT has a value of 'C882', column TYPE has a value of 'PPO', and period has value ('2013-01-01', '2020-12-31'). Suppose that you issue the following UPDATE statement:

```
UPDATE POLICY
FOR PORTION OF BUSINESS_TIME
BETWEEN '2014-01-01' AND '9999-12-31'
SET TYPE='HMO'
WHERE BK='P138', CLIENT='C882';
```

After the UPDATE statement is processed, the table contains 2 rows in place of the original row. One row with period value ('2013-01-01', '2013-12-31') has a value of 'PPO' for the TYPE column (the value before the update) and the other row with period value ('2014-01-01', '2020-12-31') has a value of 'HMO' for the TYPE column.

VALUES statement

The VALUES statement provides a method for invoking a user-defined function from a trigger. Transition variables and transition tables can be passed to the user-defined function.

Invocation for VALUES

This statement can only be used in the triggered action of a basic trigger.

VALUES followed by a *sequence-reference* is a *values-clause*, which is a form of *fullselect*. For information about invocation of the *values-clause*, see [“fullselect”](#) on page 1060.

Authorization for VALUES

Authorization is required for any expressions that are used in the statement. For more information, see [“Expressions”](#) on page 245.

Syntax for VALUES

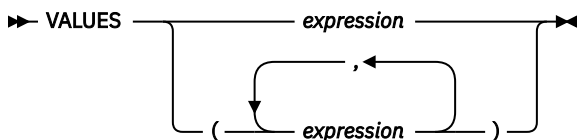

Description for VALUES

VALUES

Specifies one or more expressions. If more than one expression is specified, the expressions must be enclosed within parentheses.

expression

Any expression of the type described in [“Expressions”](#) on page 245. The expression must not contain a host variable.

The expressions are evaluated, but the resulting values are discarded and are not assigned to any output variables.

If a user-defined function is specified as part of an expression, the user-defined function is invoked. If a negative SQLCODE is returned when the function is invoked, Db2 stops executing the trigger and rolls back any triggered actions that were performed.

Example for VALUES

Example: Create an after trigger EMPISRT1 that invokes user-defined function NEWEMP when the trigger is activated. An insert operation on table EMP activates the trigger. Pass transition variables for the new employee number, last name, and first name to the user-defined function.

```
CREATE TRIGGER EMPISRT1
  AFTER INSERT ON EMP
  REFERENCING NEW AS N
  FOR EACH ROW
  MODE DB2SQL
  BEGIN ATOMIC
    VALUES(NEWEMP(N.EMPNO, N.LASTNAME, N.FIRSTNAME));
  END
```

VALUES INTO statement

The VALUES INTO statement assigns one or more values to variables.

Invocation for VALUES INTO

This statement can only be embedded in an application program. It is an executable statement that cannot be dynamically prepared.

Authorization for VALUES INTO

The privileges that are held by the authorization ID of the statement must include at least one of the following privileges or authorities:

- The SELECT privilege on every table and view identified in the statement
- Ownership of every table and view identified in the statement
- READ and WRITE privileges on any global variables that are identified in the statement
- Ownership of any global variables that are identified in the statement
- DBADM authority for the database (tables only)
- DATAACCESS authority
- SYSADM authority
- SYSCTRL authority (catalog tables only)

For an assignment to a global variable or an element of an array global variable, the privilege set must include at least one of the following:

- The WRITE privilege on the variable
- Ownership of the variable
- DATAACCESS authority
- SYSADM authority

For an assignment to a transition variable, the privilege set must include at least one of the following:

- The UPDATE privilege on the table or view on which the trigger that contains the assignment statement is defined
- The UPDATE privilege on the column corresponding to the transition variable to be assigned a value

- Ownership of the table or view on which the trigger that contains the assignment statement is defined
- DBADM authority on the database that contains the table on which the trigger that contains the assignment statement is defined
- DATAACCESS authority
- SYSADM authority

Privilege set: The privilege set is the privileges that are held by the owner of the package.

Authorization is required for any expressions that are used in the statement. For more information, see [“Expressions” on page 245](#).

Syntax for VALUES INTO

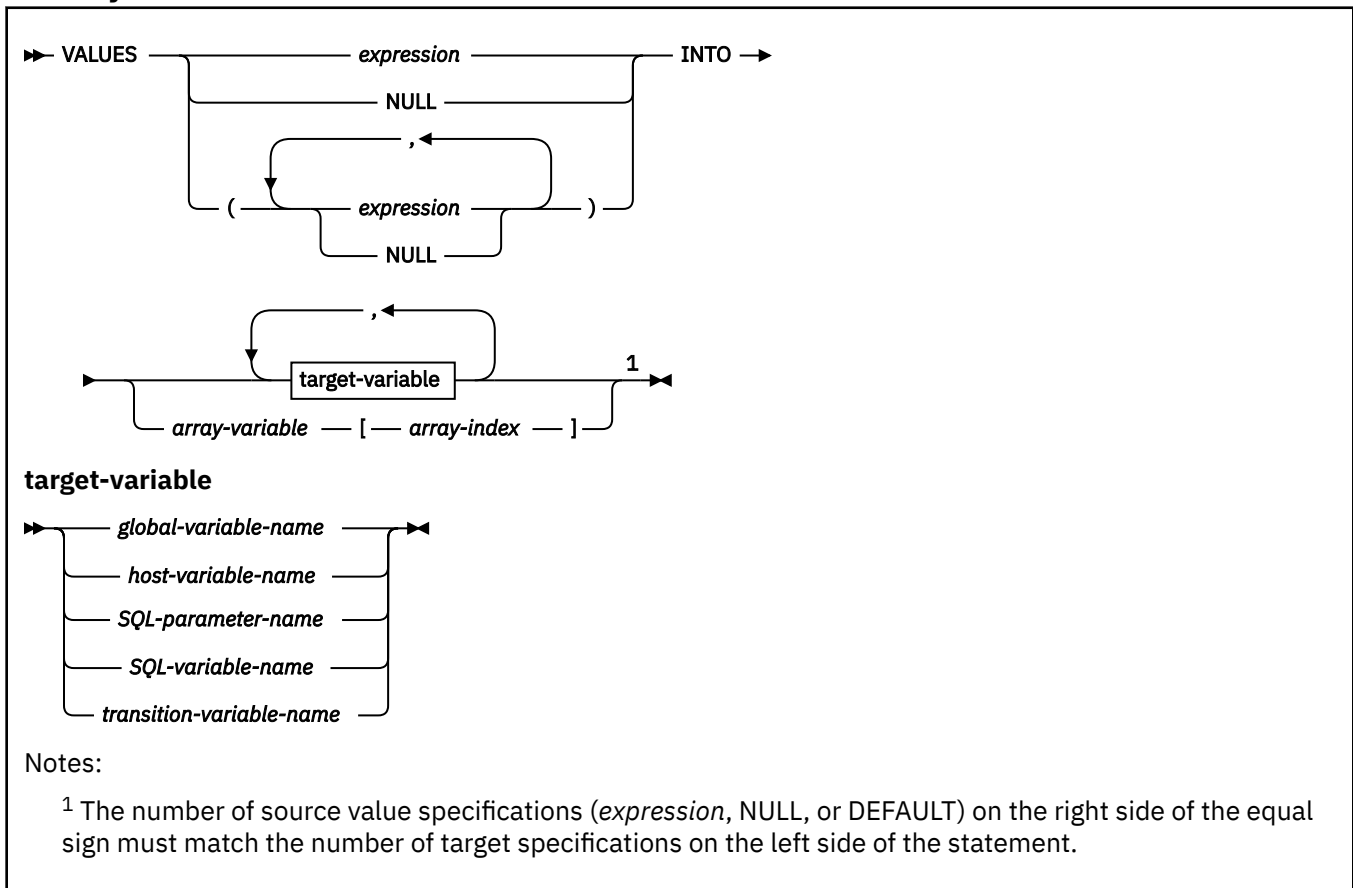

Description for VALUES INTO

VALUES

Introduces a single row that consists of one or more columns. If more than one value is specified, the list of values must be enclosed within parentheses.

expression

The expression is any expression of the type described in [“Expressions” on page 245](#). The expression must not include a column name.

NULL

The null value. NULL can only be specified for host variables that have an associated indicator variable.

INTO *target-variable* or *array-variable*[*array-index*]

Identifies one or more targets for the assignment of output values. The number of targets in the INTO clause must equal the number of values that are to be assigned. The first value in the result row is assigned to the first target in the list, the second value to the second target, and so on. A target

variable must not be specified more than once in the INTO clause. Each assignment to a target is made in sequence through the list, according to the rules described in [“Assignment and comparison”](#) on page 143.

The value 'W' is assigned to the SQLWARN3 field of the SQLCA if the number of targets is less than the number of result column values.

If an error occurs on any assignment, the value is not assigned to the target, and no more values are assigned to the specified targets. Any values that have already been assigned remain assigned.

global-variable-name

Identifies the global variable that is the assignment target.

host-variable-name

Identifies the host variable that is the assignment target. For LOB output values, the target can be a regular host variable (if it is large enough), a LOB locator variable, or a LOB file reference variable.

SQL-parameter-name

Identifies the parameter that is the assignment target.

SQL-variable-name

Identifies the SQL variable that is the assignment target. SQL variables must be declared before they are used.

transition-variable-name

Identifies the column that is to be updated in the transition table. A *transition-variable-name* must identify a column in the subject table of a trigger, optionally qualified by a correlation name, that identifies the new value.

array-variable [array-index]

Specifies an array element that is the target of the assignment.

An array element must not be specified as the target for an assignment if *common-table-expression* is also specified in the statement.

array-variable

Specifies an array variable.

[array-index]

An expression that specifies which element in the array is the target of the assignment.

For an ordinary array, the array index expression must be castable to INTEGER, and must not be the null value. The index value must be between 1 and the maximum cardinality that is defined for the array.

For an associative array, the array index expression must be castable to the index data type of the associative array, and must not be the null value.

array-index must not be:

- An expression that references the CURRENT DATE, CURRENT TIME, or CURRENT TIMESTAMP special register
- A nondeterministic function
- A function that is defined with EXTERNAL ACTION
- A function that is defined with MODIFIES SQL DATA
- A sequence expression

Notes for VALUES INTO

Assignment to targets:

The *n*th target identified by the INTO clause corresponds to the *n*th column of the result table of the cursor. The data type of the target must be compatible with its corresponding value. If the value is numeric, the target must have the capacity to represent the whole part of the value. For a datetime value, the target must be a character string variable of a minimum length as defined in [“String](#)

representations of datetime values” on page 120. When the value that is to be assigned is null, an indicator variable must be specified for the target variable.

Assignments are made in sequence through the list. Each assignment to a target is made according to the rules described in Chapter 2, “Language elements in SQL,” on page 75. If the number of targets is less than the number of values in the row, the SQLWARN3 field of the SQLCA is set to 'W'. There is no warning if there are more targets than the number of result columns. If a null value is assigned to a target variable, an indicator variable must be provided. If an assignment error occurs, the value is not assigned to the target and no more values are assigned to targets. Any values that have already been assigned to targets remain assigned. However, if LOB values are involved, there is a possibility that the corresponding target was modified, but the variable's contents are unpredictable.

If more than one assignment is included in the same assignment statement, all expressions are evaluated before the assignments are performed. For example, a reference to a variable in an expression always uses the value of the variable prior to any assignment in the assignment statement.

Normally, you use LOB locators to assign and retrieve data from LOB columns. However, because of compatibility rules, you can also use LOB locators to assign data to targets with other data types. For more information on using locators, see [Saving storage when manipulating LOBs by using LOB locators \(Db2 Application programming and SQL\)](#).

Default encoding scheme:

The default encoding scheme for the data is the value in the bind option ENCODING, which is the option for application encoding. If this statement is used with functions such as LENGTH or SUBSTRING that are operating on LOB locators, and the LOB data that is specified by the locator is in a different encoding scheme from the ENCODING bind option, LOB materialization and character conversion occur. To avoid LOB materialization and character conversion, select the LOB data from the SYSIBM.SYSDUMMYA, SYSIBM.SYSDUMMYE, or SYSIBM.SYSDUMMYU sample table.

Examples for VALUES INTO

Example 1: Assign the value of the CURRENT PATH special register to host variable *HV1*.

```
EXEC SQL VALUES(CURRENT PATH)
        INTO :HV1;
```

Example 2: Assign the value of the CURRENT MEMBER special register to host variable *MEM*.

```
EXEC SQL VALUES(CURRENT MEMBER)
        INTO :MEM;
```

Example 3: Assume that LOB locator *LOB1* is associated with a CLOB value. Assign a portion of the CLOB value to host variable *DETAILS* using the LOB locator.

```
EXEC SQL VALUES (SUBSTR(:LOB1,1,35))
        INTO :DETAILS;
```

If the LOB data that is specified by the LOB locator *LOB1* is in a different encoding scheme from the value of the ENCODING bind option, and you want to avoid LOB materialization and character conversion, use the following statement instead of the VALUES INTO statement:

```
EXEC SQL SELECT SUBSTR(:LOB1,1,35)
        INTO :DETAILS
        FROM SYSIBM.SYSDUMMYU;
```

Example 4: Using a VALUES INTO statement, retrieve the value of INTVAR1 into an element in array MYINTARRAY1, which is indexed by the value of the expression INTCOL2+MYINTVAR+1.

```
VALUES INTVAR1 INTO MYINTARRAY1[INTCOL2+MYINTVAR+1];
```

WHENEVER statement

The WHENEVER statement specifies the host language statement to be executed when a specified exception condition occurs.

Invocation for WHENEVER

This statement can only be embedded in an application program. It is not an executable statement. It must not be specified in Java or REXX.

Authorization for WHENEVER

None required.

Syntax for WHENEVER

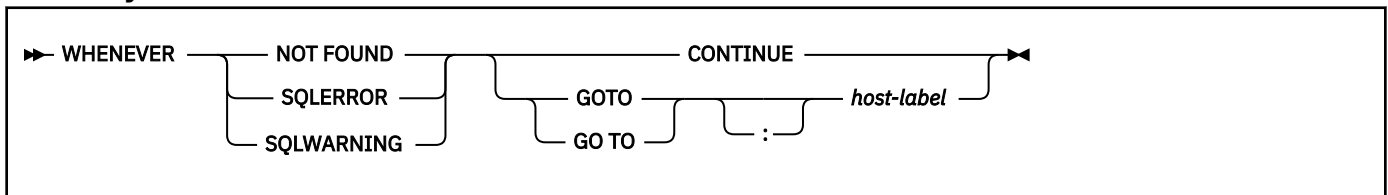

Description for WHENEVER

The NOT FOUND, SQLERROR, or SQLWARNING clause is used to identify the type of exception condition.

NOT FOUND

Identifies any condition that results in an SQLCODE of +100 (equivalently, an SQLSTATE code of '02000').

SQLERROR

Identifies any condition that results in a negative SQLCODE.

SQLWARNING

Identifies any condition that results in a warning condition (SQLWARN0 is W), or that results in a positive SQLCODE other than +100.

The CONTINUE or GO TO clause specifies the next statement to be executed when the identified type of exception condition exists.

CONTINUE

Specifies the next sequential statement of the source program.

GOTO or GOTO *host-label*

Specifies the statement identified by *host-label*. For *host-label*, substitute a single token, optionally preceded by a colon. The form of the token depends on the host language. In COBOL, for example, it can be *section-name* or an unqualified *paragraph-name*.

Notes for WHENEVER

There are three types of WHENEVER statements:

- WHENEVER NOT FOUND
- WHENEVER SQLERROR
- WHENEVER SQLWARNING

Every executable SQL statement in an application program is within the scope of one implicit or explicit WHENEVER statement of each type. The scope of a WHENEVER statement is related to the listing sequence of the statements in the application program, not their execution sequence.

An SQL statement is within the scope of the last WHENEVER statement of each type that is specified before that SQL statement in the source program. If a WHENEVER statement of some type is not specified

before an SQL statement, that SQL statement is within the scope of an implicit WHENEVER statement of that type in which CONTINUE is specified. If a WHENEVER statement is specified in a Fortran subprogram, its scope is that subprogram, not the source program.

The GET DIAGNOSTICS statement can be used to provide additional information.

Examples for WHENEVER

The following statements can be embedded in a COBOL program.

Example 1: Go to the label HANDLER for any statement that produces an error.

```
EXEC SQL WHENEVER SQLERROR GOTO HANDLER END-EXEC.
```

Example 2: Continue processing for any statement that produces a warning.

```
EXEC SQL WHENEVER SQLWARNING CONTINUE END-EXEC.
```

Example 3: Go to the label ENDDATA for any statement that does not return.

```
EXEC SQL WHENEVER NOT FOUND GO TO ENDDATA END-EXEC.
```

Chapter 8. SQL procedural language (SQL PL)

SQL can be used as a structured programming language to write the body for SQL functions, native SQL procedures, and advanced triggers. This is known as the SQL procedural language (SQL PL). SQL PL includes a set of SQL control statements.

SQL procedures and SQL functions are collectively referred to as SQL routines. SQL procedures are created by specifying an SQL routine body on the CREATE PROCEDURE statement. SQL functions are created by specifying an SQL routine body on the CREATE FUNCTION statement. Triggers are created by specifying an SQL trigger body on the CREATE TRIGGER statement.

SQL control statements

SQL control statements are SQL statements that allow SQL to be used as a structured programming language. SQL control statements provide the capability to control the logic flow, declare and set variables, and handle warnings and exceptions. Some SQL control statements include other nested SQL statements.

SQL-control-statement:

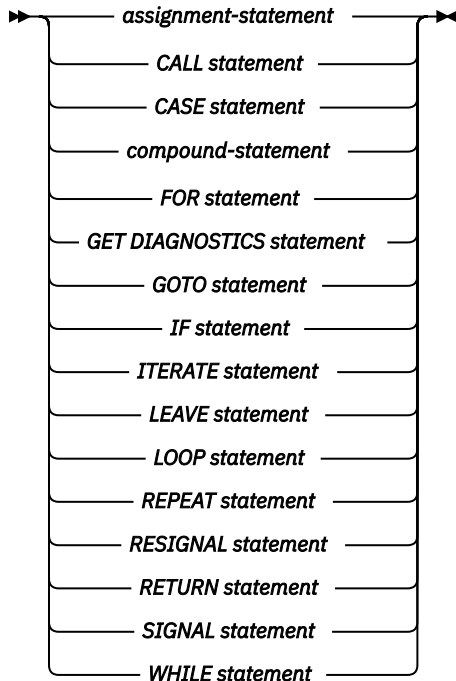

Control statements are supported in native SQL procedures, compiled SQL functions, and advanced triggers.

- SQL functions are created by specifying LANGUAGE SQL and an SQL routine body in a CREATE FUNCTION (compiled SQL) statement. An SQL function can be changed. A new SQL routine body can be specified in an ALTER FUNCTION (compiled SQL) statement.
- SQL procedures are created by specifying LANGUAGE SQL and an SQL routine body in a CREATE PROCEDURE (SQL - native) statement. An SQL procedure can be changed. A new SQL routine body can be specified in an ALTER PROCEDURE (SQL - native) statement.
- Triggers are created by specifying a trigger body on the CREATE TRIGGER (advanced) statement. See [“CREATE TRIGGER statement \(advanced trigger\)”](#) on page 1740. Advanced triggers can be changed. The body of a trigger can be changed by specifying the OR REPLACE clause on a CREATE TRIGGER (advanced) statement, or with an ALTER TRIGGER (advanced) statement.

The SQL routine body or trigger body is the executable part of the routine or trigger and is transformed by Db2 into a program. The body must be a single SQL statement, which might be an SQL control statement.

The remainder of this section contains a description of the control statements that are supported by SQL routines and advanced triggers, and includes syntax diagrams, semantic descriptions, usage notes, and examples of the use of the statements that constitute the SQL routine body or trigger body. In addition, you can find information about referencing SQL parameters and variables in [“References to SQL parameters and variables in SQL PL”](#) on page 2208.

The two common elements that are used in describing specific SQL control statements are:

- SQL control statements as described above
- [“SQL-procedure-statement \(SQL PL\)”](#) on page 2212

Related reference

[CREATE PROCEDURE statement \(SQL - native procedure\)](#)

The CREATE PROCEDURE statement defines an SQL procedure, or a version of a procedure, at the current server and specifies the source statements for the procedure.

[CREATE FUNCTION statement \(compiled SQL scalar function\)](#)

The CREATE FUNCTION (compiled SQL scalar) statement defines a compiled SQL scalar function at the current server and specifies the source statements for the function. The body of the function is written in the SQL procedural language. The function returns a single value each time it is invoked.

[CREATE TRIGGER statement \(advanced trigger\)](#)

References to SQL parameters and variables in SQL PL

Variables can be referenced in SQL statements in SQL functions, SQL procedures, and triggers. However, host variables cannot be specified in these objects. Instead, depending on the context, SQL variables, SQL parameters, transition variables, and global variables can be referenced anywhere in an SQL statement where an expression or variable can be specified in SQL functions, SQL procedures, and triggers. SQL variables can be referenced anywhere in the compound statement in which they are declared, including any SQL statement that is directly or indirectly nested within that compound statement. SQL parameters can be referenced in an SQL function or SQL procedure body. Transition variables can be referenced in a trigger body.

Ambiguity can arise in an SQL statement with variables, particularly when two or more variables have the same name or when a variable and another object have the same name. In such situations, it might be confusing to determine which variable is referenced and whether the identifier is the name of a variable or another object, such as a column. If the identifier is the name of a variable, it might be difficult to determine whether the reference is intended for an SQL variable, SQL parameter, transition variable, or global variable.

The name of an SQL variable, SQL parameter, or global variable in an SQL function or SQL procedure can be the same as the name of a column in a table or view referenced in the function or procedure. The name of an SQL variable, transition variable, or global variable in a trigger can be the same as the name of a column in a table or view that is referenced in the trigger. The name of an SQL variable can also be the same as the name of another SQL variable declared in the same function, procedure, or trigger. This can occur when the two SQL variables are declared in different compound statements. The *compound-statement* that contains the declaration of an SQL variable determines the scope of that variable. See [“compound-statement”](#) on page 2221 for additional information.

Names that are the same should be explicitly qualified. Qualifying a name can clarify whether the name refers to a column, global variable, SQL variable, SQL parameter, or transition variable:

- An SQL parameter can be qualified with the name of the SQL function or SQL procedure.
- An SQL variable can be qualified with the label of the compound statement where an SQL variable is declared.
- A transition variable can be qualified with the correlation name specified in the CREATE TRIGGER or ALTER TRIGGER statement.

- A global variable can be qualified with the schema implicitly or explicitly specified when the global variable is created.

If the name is not qualified, or qualified but still ambiguous, the following rules describe how the name is resolved. The name is resolved by checking for a match in the following order:

- If the tables and views specified in an SQL function or SQL procedure at the time the function or procedure is created, the name is first checked as a column.
- If not found as a column, the name is checked as an SQL variable, SQL parameter, or transition variable. An SQL variable can be declared within the *compound-statement* that contains the reference, or within a compound statement in which that compound statement is nested. If two SQL variables, an SQL variable and an SQL parameter, or an SQL variable and a transition variable, have the same name, the SQL variable that is declared in the innermost compound statement is used.
- If not found as an SQL variable name, the name is checked as an SQL parameter name or transition variable.
- If not found as an SQL parameter or transition variable, the name is checked as a global variable.

If the name is still not resolved as a column, SQL variable, SQL parameter, global variable, or transition variable and the scope of the name included a table or view that does not exist at the current server, it is assumed to be a column. If all the tables and views exist at the current server, it is assumed to be a global variable. Otherwise, an error is returned.

The name of an SQL variable, SQL parameter, transition variable, or global variable in an SQL function, SQL procedure, or trigger can be the same as an identifier used as a name in certain SQL statements. Qualified names for SQL variables, SQL parameters, or transition variables are not supported in these statements. The following rules describe how the name is resolved in these statements.

- In the SET PATH or SET SCHEMA statements, the name is checked as an SQL variable, SQL parameter, transition variable, or global variable. If an SQL variable, SQL parameter, transition variable, or global variable by that name is not found, the name is assumed to be a schema name.
- In the CONNECT, RELEASE, and SET CONNECTION statements, the name is used as a server name.
- In the CALL statement, the name is used as the procedure name.
- In the ASSOCIATE LOCATORS, or DESCRIBE PROCEDURE statement, the name is used as the procedure name.

Related concepts

Variables

A *variable* in an SQL statement specifies a value that can be changed when the SQL statement is executed. There are several types of variables used in SQL statements.

References to SQL condition names

A condition name can only be referenced within the compound statement in which it is declared, including any compound statements that are nested within that compound statement. When there is a reference to a condition name, the condition that is declared in the innermost compound statement is the condition that is used.

The name of an SQL condition can be the same as the name of another SQL condition that is declared in the same routine or advanced trigger. This can occur when the two SQL conditions are declared in different *compound-statements*. The *compound-statement* that contains the declaration of an SQL condition name determines the scope of that condition name. A condition name must be unique within the compound statement in which it is declared, excluding any declarations in compound statements that are nested within that compound statement. A condition name can only be referenced within the compound statement in which it is declared, including any compound statements that are nested within that compound statement. When there is a reference to a condition name, the condition that is declared in the innermost compound statement is the condition that is used. See [“compound-statement” on page 2221](#) for additional information.

References to SQL cursor names

A cursor name can only be referenced within the compound statement in which it is declared, including any compound statements that are nested within that compound statement.

The name of an SQL cursor can be the same as the name of another SQL cursor that is declared in the same routine or advanced trigger. This can occur when the two SQL cursors are declared in different compound statements. The compound statement that contains the declaration of an SQL cursor determines the scope of that cursor name. A cursor name must be unique within the compound statement in which it is declared, excluding any declarations in compound statements that are nested within that compound statement. A cursor name can only be referenced within the compound statement in which it is declared, including any compound statements that are nested within that compound statement. When there is a reference to a cursor name, the cursor that is declared in the innermost compound statement is the cursor that is used. See [“compound-statement” on page 2221](#) for additional information.

References to SQL labels

Labels can be specified on most SQL procedure statements in an SQL function, SQL procedure, or advanced trigger. If a label is specified on an SQL procedure statement, it must be unique from other labels within the same scope. A label must not be the same as any other label within the same compound statement, must not be the same as a label specified on the compound statement itself, and if the compound statement is nested within another compound statement, the label must not be the same as the label specified on any higher level compound statement. The label must not be the same as the name of the SQL function or SQL procedure.

Specifying a label for an SQL procedure statement defines that label and determines the scope of that label. A label name can only be referenced within the compound statement in which it is defined, including a reference from any statement that is directly or indirectly nested within that compound statement. The FOR statement is considered the same as a compound statement with respect to defining and referencing labels. A label can be specified as the target of a GOTO, LEAVE, or ITERATE statement, subject to the rules for the statement that references the label as a target.

References to SQL statement names

The name of an SQL statement can be the same as the name of another SQL statement declared in the same routine or advanced trigger.

This can occur when the two SQL statements are declared in different compound statements. The compound statement that contains the declaration of an SQL statement name determines the scope of that statement name. A statement name must be unique within the compound statement in which it is declared, excluding any declarations in compound statements that are nested within that compound statement. A statement name can only be referenced within the compound statement in which it is declared, including any compound statements that are nested within that compound statement. When there is a reference to a statement name, the statement that is declared in the innermost compound statement is the statement that is used.

Summary of name scoping in nested compound statements

Nested compound statements can be used within an SQL routine or advanced trigger to define the scope of SQL variable declarations, cursors, condition names, and condition handlers.

In addition, labels have a defined scope in the context of nested compound statements. However, the rules for name spaces and how non-unique names can be referenced, differs depending on the type of name. The following table summarizes these differences:

Table 241. Scope and qualification of names within nested compound statements

Type of name	Name can be qualified	Name must be unique within	Name can be referenced within
SQL variable	Yes. The name can be qualified with the label of the compound statement in which the variable is declared	the compound statement in which it is declared, excluding any declarations in compound statements that are nested within that compound statement	<p>The compound statement in which it is declared, including any compound statements that are nested within that compound statement.</p> <p>When multiple SQL variables are defined with the same name, a label can be used to explicitly refer to a specific variable that is not the most local in scope</p>
condition name	No	the compound statement in which it is declared, excluding any declarations in compound statements that are nested within that compound statement	<p>The compound statement in which it is declared, including any compound statements that are nested within that compound statement.</p> <p>Condition names can be used in the declaration of a condition handler, or in a SIGNAL or RESIGNAL statement.</p> <p>If multiple conditions are defined with the same name, there is no way to explicitly refer to the condition that is not the most local in scope.</p>
cursor name	No	the routine	<p>The compound statement in which it is declared, including any compound statements that are nested within that compound statement.</p> <p>If the cursor is defined as a result set cursor, the invoking application can access the result set.</p>
label	No	the compound statement that defined the label, including any definitions in compound statements that are nested within that compound statement	<p>The compound statement in which it is defined, including any compound statements that are nested within that compound statement.</p> <p>Use a label to qualify the name of an SQL variable or as the target of a GOTO, LEAVE, or ITERATE statement, subject to the rules for these statements.</p>

SQL-procedure-statement (SQL PL)

An SQL control statement can allow multiple SQL statements to be specified within the SQL control statement. These statements are defined as SQL procedure statements.

Syntax

SQL-control-statement	
ALLOCATE CURSOR statement	
ALTER DATABASE statement	(1, 2)
ALTER FUNCTION statement (external scalar, external table, sourced, SQL scalar, or SQL table)	(2, 3)
ALTER INDEX statement	(1, 2)
ALTER MASK statement	(1, 2)
ALTER PERMISSION statement	(1, 2)
ALTER PROCEDURE statement (external SQL - external, or SQL - native)	(2)
ALTER SEQUENCE statement	(1, 2)
ALTER STOGROUP statement	(1, 2)
ALTER TABLE statement	(1, 2)
ALTER TABLESPACE statement	(1, 2)
ALTER TRIGGER statement	(1, 2)
ALTER TRUSTED CONTEXT statement	(1, 2)
ALTER VIEW statement	(1, 2)
ASSOCIATE LOCATORS statement	
CALL statement	
CLOSE statement	
COMMENT statement	(1, 3)
COMMIT statement	(6)
CONNECT statement	(7)
CREATE ALIAS statement	(1, 2)
CREATE DATABASE statement	(1, 2)
CREATE FUNCTION statement (external scalar, external table, or sourced)	(1, 2)
CREATE GLOBAL TEMPORARY TABLE statement	(1, 2)
CREATE INDEX statement	(1,3)
CREATE PROCEDURE statement (external)	(1, 2)
CREATE ROLE statement	(1, 2)
CREATE SEQUENCE statement	(1, 2)
CREATE STOGROUP statement	(1, 2)
CREATE SYNONYM statement	(1, 2)
CREATE TABLE statement	(9)
CREATE TABLESPACE statement	(1, 2)
CREATE TRUSTED CONTEXT statement	(1, 2)
CREATE TYPE (array) statement	(1, 2)
CREATE TYPE (distinct) statement	(1, 2)
CREATE VARIABLE statement	(1, 2)
CREATE VIEW statement	(1, 3)

Syntax (continued)

DECLARE CURSOR statement
DECLARE GLOBAL TEMPORARY TABLE statement (1, 2)
DELETE statement (3)
DROP statement (4)
EXCHANGE statement (1, 2)
EXECUTE statement
EXECUTE IMMEDIATE statement
FETCH statement (5)
GET DIAGNOSTICS statement
GRANT statement (1, 2)
INSERT statement (3)
LABEL statement (1,3)
LOCK TABLE statement (1,3)
MERGE statement (3)
OPEN statement
PREPARE statement
REFRESH TABLE statement (3)
RELEASE statement (7)
RELEASE SAVEPOINT statement
RENAME statement
REVOKE statement
ROLLBACK statement (with TO SAVEPOINT clause) (1, 2)
ROLLBACK statement (without TO SAVEPOINT clause) (6)
SAVEPOINT statement (1, 3)
SELECT INTO statement
SET assignment-statement statement
SET CONNECTION statement (7)
SET special-register statement (8)
TRUNCATE statement (3)
UPDATE statement (3)
VALUES INTO statement

Notes:

The following notes are used both in the preceding syntax diagram and sometimes also in the following table.

1. The statement is not allowed in an *SQL-routine-body* for an SQL function.
2. The statement is not allowed in an *SQL-trigger-body* for a trigger, and a procedure containing the statement must not be invoked directly, or indirectly, from the body of a BEFORE trigger.
3. The statement is not allowed in an *SQL-trigger-body* for a BEFORE trigger, and a procedure containing the statement must not be invoked directly, or indirectly, from the body of a BEFORE trigger.
4. The only DROP statements that are allowed are DROP TABLE, DROP VIEW, and DROP INDEX.
5. A FETCH statement must not specify a *fetch-orientation* clause, *multiple-row-fetch* clause, the WITH CONTINUE or the CURRENT CONTINUE clauses.
6. The COMMIT and ROLLBACK (without the TO SAVEPOINT clause) statements must only be specified within the body of an SQL procedure.
7. The CONNECT, RELEASE *connection*, and SET CONNECTION statements must only be specified within the body of an SQL procedure.
8. SET *special-register* statements are allowed in an *SQL-trigger-body* for a trigger, except for SET CURRENT PACKAGE PATH and SET CURRENT PACKAGESET.
9. A CREATE TABLE statement must not include a column defined as a LOB or XML column.

The following table summarizes which SQL statements can be used in *SQL-procedure-body*, *SQL-function-body*, or in a *SQL-trigger-body* or procedure referenced in a BEFORE trigger. (That is, it corresponds to notes “1” on page 2213, “2” on page 2213, and “3” on page 2213 in the syntax diagram.)

Statement	Allowed in SQL procedure body?	Allowed in SQL function body?	Allowed in SQL trigger body or procedure invoked by a BEFORE trigger?
<i>SQL-control-statement</i>	Yes	Yes	Yes

Statement	Allowed in SQL procedure body?	Allowed in SQL function body?	Allowed in SQL trigger body or procedure invoked by a BEFORE trigger?
ALLOCATE CURSOR	Yes	Yes	Yes
ALTER DATABASE	Yes	No	No
ALTER FUNCTION (external scalar, external table, sourced, SQL scalar, or SQL table)	Yes “3” on page 2213	Yes “3” on page 2213,	No
ALTER MASK	Yes	No	No
ALTER PERMISSION	Yes	No	No
ALTER PROCEDURE (external, SQL - external, or SQL - native)	Yes	Yes	No
ALTER SEQUENCE	Yes	No	No
ALTER STOGROUP	Yes	No	No
ALTER TABLE	Yes	No	No
ALTER TABLESPACE	Yes	No	No
ALTER TRIGGER	Yes	No	No
ALTER TRUSTED CONTEXT	Yes	No	No
ALTER VIEW	Yes	No	No
ASSOCIATE LOCATORS	Yes	Yes	Yes
CALL	Yes	Yes	Yes
CLOSE	Yes	Yes	Yes
COMMENT	Yes	No	Yes “3” on page 2213
COMMIT	No	No	Yes
CONNECT	Yes	Yes	No
CREATE ALIAS	Yes	No	No
CREATE DATABASE	Yes	No	No
CREATE FUNCTION	Yes	No	No
CREATE GLOBAL TEMPORARY TABLE	Yes	No	No
CREATE INDEX	Yes	No	No
CREATE PROCEDURE (external)	Yes	No	No
CREATE ROLE	Yes	No	No
CREATE SEQUENCE	Yes	No	No
CREATE STOGROUP	Yes	No	No
CREATE SYNONYM	Yes	No	No
CREATE TABLE	Yes “9” on page 2213	Yes “9” on page 2213	Yes “3” on page 2213, “9” on page 2213

Statement	Allowed in SQL procedure body?	Allowed in SQL function body?	Allowed in SQL trigger body or procedure invoked by a BEFORE trigger?
CREATE TABLESPACE	Yes	No	No
CREATE TRUSTED CONTEXT	Yes	No	No
CREATE TYPE (array)	Yes	No	No
CREATE TYPE (distinct)	Yes	No	No
CREATE VARIABLE	Yes	No	No
CREATE VIEW	Yes	No	Yes “3” on page 2213
DECLARE CURSOR	Yes	Yes	Yes
DELETE	Yes	No	Yes “3” on page 2213
DROP	Yes	No	Yes
EXCHANGE	Yes	No	No
EXECUTE	Yes	Yes	Yes
EXECUTE IMMEDIATE	Yes	Yes	Yes
FETCH	Yes “4” on page 2213	Yes “4” on page 2213	Yes “4” on page 2213
GET DIAGNOSTICS	Yes	Yes	Yes
GRANT	Yes	No	No
INSERT	Yes	Yes	Yes “3” on page 2213
LABEL	Yes	No	Yes “3” on page 2213
LOCK TABLE	Yes	No	Yes “3” on page 2213
MERGE	Yes	Yes	Yes “3” on page 2213
OPEN	Yes	Yes	Yes
PREPARE	Yes	Yes	Yes
REFRESH TABLE	Yes	Yes	Yes “3” on page 2213
RELEASE <i>connection</i>	Yes	No	No
RELEASE SAVEPOINT	Yes	No	No
RENAME	Yes	No	No
REVOKE	Yes	No	No
ROLLBACK (with TO SAVEPOINT clause)	Yes	No	No
ROLLBACK (without TO SAVEPOINT clause)	Yes	Yes	No
SAVEPOINT	Yes	No	No
SELECT INTO	Yes	Yes	Yes
SET <i>assignment-statement</i>	Yes	Yes	Yes “8” on page 2213
SET CONNECTION	Yes	No	No

Statement	Allowed in SQL procedure body?	Allowed in SQL function body?	Allowed in SQL trigger body or procedure invoked by a BEFORE trigger?
SET <i>special-register</i>	Yes	Yes “8” on page 2213	Yes
TRUNCATE	Yes	Yes	Yes “3” on page 2213
UPDATE	Yes	Yes	Yes “3” on page 2213
VALUES INTO	Yes	Yes	Yes

Description

SQL-control-statement

Specifies an SQL statement that provides the capability to control logic flow, declare and set variables, and handle warnings and exceptions, as defined in this section. Control statements are supported in SQL routines.

SQL-statement

Specifies an SQL statement. These statements are described in [Chapter 7, “Statements,” on page 1079](#).

Notes

Comments

Comments can be included within the body of an SQL routine. In addition to the double-dash form of comments (--), a comment can begin with /* and end with */. The following rules apply to this form of comment:

- The beginning characters /* must be adjacent and on the same line.
- The ending characters */ must be adjacent and on the same line.
- Comments can be started wherever a space is valid.
- Comments can be continued to the next line.

Detecting and processing error and warning conditions

As an SQL statement is executed, Db2 stores information about the processing of the statement in a diagnostics area (including the SQLSTATE and SQLCODE), unless otherwise noted in the description of the SQL statement. A completion condition can indicate that the SQL statement completed successfully, completed with a warning condition, or completed with a not found condition. An exception condition indicates that the SQL statement was not successful.

A condition handler can be defined to execute when an exception condition, a warning condition, or a not found condition occurs in a compound statement. The declaration of a condition handler includes the code that is executed when the condition handler is activated. When a condition other than a successful completion occurs in the processing of *SQL-procedure-statement* and a condition handler that can handle the condition is within scope, one such condition handler will be activated to process the condition. See [“compound-statement” on page 2221](#) for information about defining condition handlers. The code in the condition handler can check for a warning condition, a not found condition, or an exception condition and can take the appropriate action. Use one of the following methods at the beginning of the body of a condition handler to check the condition in the diagnostics area that caused the handler to be activated.

- Issue a GET DIAGNOSTICS statement to request the information from the diagnostics area. See [“GET DIAGNOSTICS statement” on page 1949](#).
- Test the SQLSTATE and SQLCODE SQL variables.

If the condition is a warning and no handler exists for the condition, the previous two methods can be used outside of the body of a condition handler, if they are used immediately following the statement for which the condition is wanted. If the condition is an error and no handler exists for the condition, the routine terminates with the error condition.

assignment-statement

The assignment statement assigns a value to variables or array elements. For example, the target value can be an SQL parameter or an SQL variable.

Syntax

```
label: SET — assignment-clause
```

Description

label

Specifies the label for *assignment-statement*. The label name cannot be the same as the routine name, advanced trigger name, or another label within the same scope. For additional information, see “References to SQL labels” on page 2210.

See “SET assignment-statement statement” on page 2124 for details.

Notes

Assignment rules: Assignment statements in SQL routines and triggers must conform to the SQL assignment rules. For example, the data type of the target and source must be compatible. See “Assignment and comparison” on page 143 for assignment rules.

When a string is assigned to a fixed-length variable and the length of the string is less than the length attribute of the target, the string is padded on the right with the necessary number of single-byte or double-byte blanks. When a string is assigned to a variable and the string is longer than the length attribute of the variable, the value is truncated and a warning is returned.

If truncation of the whole part of a number occurs on assignment to a numeric variable, the value is truncated and a warning is returned.

Assignments involving SQL parameters for SQL procedures: An IN parameter can appear on the left or right side in an assignment statement. When control returns to the caller, the original value of the IN parameter is retained. An OUT parameter can also appear on the left or right side in an assignment statement. If used without first being assigned a value, the value is undefined. When control returns to the caller, the last value that is assigned to an OUT parameter is returned to the caller. For an INOUT parameter, the first value of the parameter is determined by the caller, and the last value that is assigned to the parameter is returned to the caller.

Multiple assignments: If more than one assignment is included in the same assignment statement, all *expressions* are evaluated before the assignments are performed. Thus, references to an SQL variable or SQL parameter in an expression always use the value of the SQL variable or SQL parameter prior to any assignment in the assignment statement.

Considerations for SQLSTATE and SQLCODE SQL variables: Assignment to these variables is not prohibited. However, it is not recommended as assignment does not affect the diagnostic area or result in the activation of condition handlers. Furthermore, processing an assignment to these SQL variables causes the specified values for the assignment to be overlaid with the SQL return codes returned from executing the statement that does the assignment.

CALL statement

The CALL statement invokes a stored procedure.

Syntax

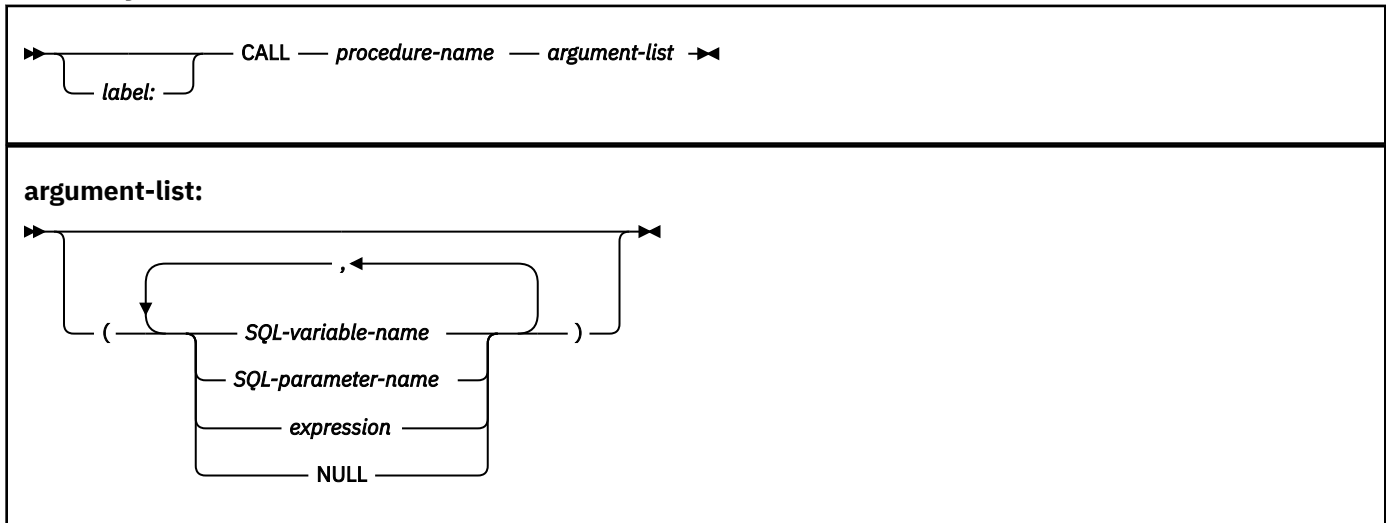

Description

label

Specifies the label for the CALL statement. The label name cannot be the same as the routine name, advanced trigger name, or another label within the same scope. For additional information, see [“References to SQL labels” on page 2210](#).

procedure-name

Identifies the stored procedure to call. The procedure name must identify a stored procedure that exists at the current server.

argument-list

Identifies a list of values to be passed as parameters to the stored procedure. The *n*th value corresponds to the *n*th parameter in the procedure. The number of parameters must be the same as the number of parameters defined for the stored procedure. See [“CALL statement” on page 1384](#) for more information.

Control is passed to the stored procedure according to the calling conventions for SQL routines. When execution of the stored procedure is complete, the value of each parameter of the stored procedure is assigned to the corresponding parameter of the CALL statement defined as OUT or INOUT.

SQL-variable-name

Specifies an SQL variable as an argument to the stored procedure. For an explanation of references to SQL variables, see [“References to SQL parameters and variables in SQL PL” on page 2208](#).

SQL-parameter-name

Specifies an SQL parameter as an argument to the stored procedure. For an explanation of references to SQL parameters, see [“References to SQL parameters and variables in SQL PL” on page 2208](#).

expression

The parameter is the result of the specified *expression*, which is evaluated before the stored procedure is invoked. If *expression* is a single *SQL-parameter-name* or *SQL-variable-name*, the corresponding parameter of the procedure can be defined as IN, INOUT, or OUT. Otherwise, the corresponding parameter of the procedure must be defined as IN. If the result of the *expression* can be the null value, either the description of the procedure must allow for null parameters or the corresponding parameter of the stored procedure must be defined as OUT.

The following additional rules apply depending on how the corresponding parameter was defined in the CREATE PROCEDURE statement for the procedure:

- IN *expression* can contain references to multiple SQL parameters or variables. In addition to the rules stated in “Expressions” on page 245 for *expression*, *expression* cannot include a column name, an aggregate function, or a user-defined function that is sourced on an aggregate function.
- INOUT or OUT *expression* can only be a single SQL parameter or variable.

NULL

The parameter is a null value. The corresponding parameter of the procedure must be defined as IN and the description of the procedure must allow for null parameters.

Notes

See “CALL statement” on page 1384 for more information on the SQL CALL statement.

Examples

Call stored procedure proc1 and pass SQL variables as parameters.

```
CALL proc1(v_empno, v_salary)
```

CASE statement

The CASE statement selects an execution path based on multiple conditions. A CASE statement operates in the same way as a CASE expression.

Syntax

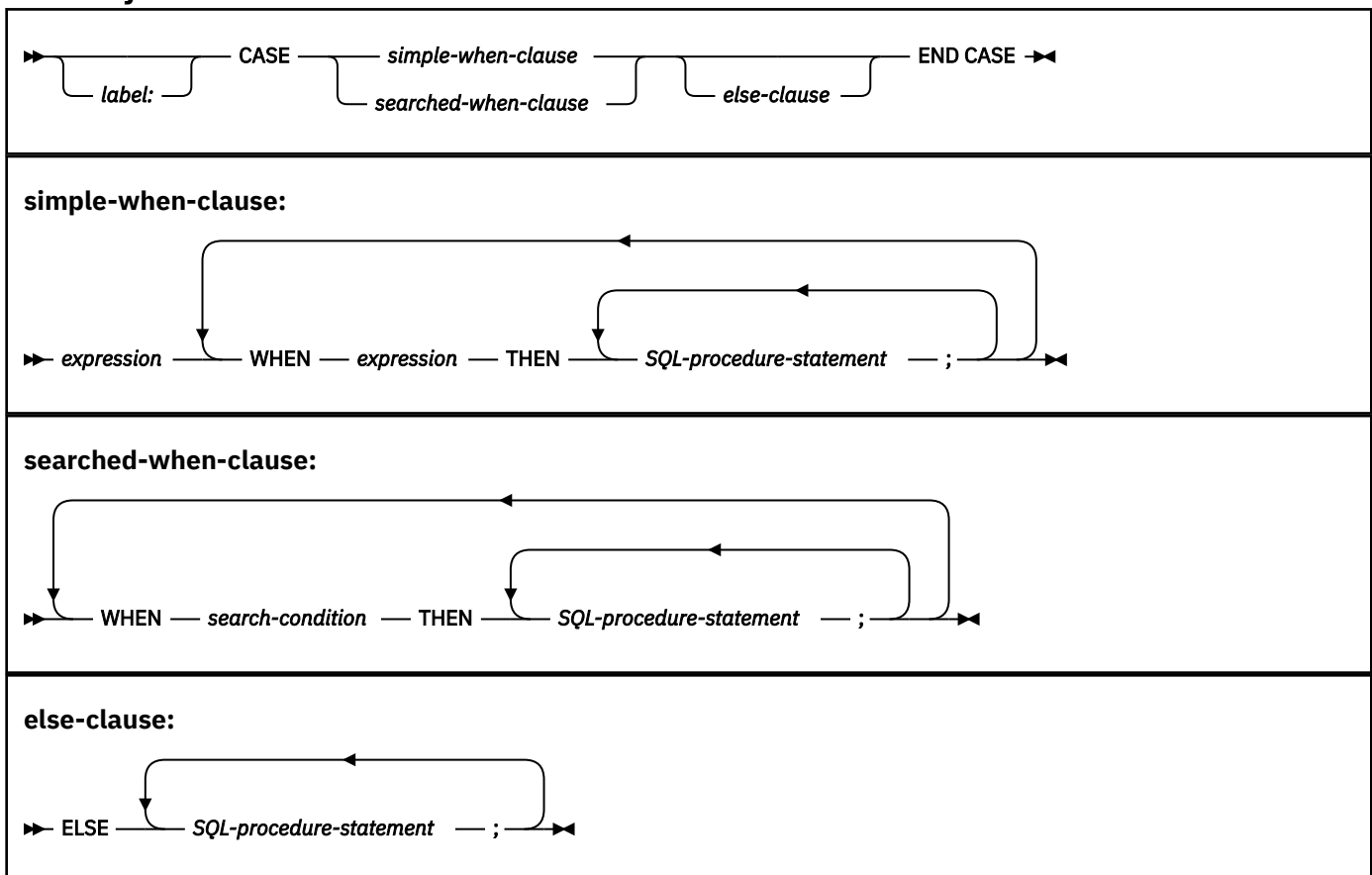

Description

label

Specifies the label for the CASE statement. The label name cannot be the same as the routine name, advanced trigger name, or another label within the same scope. For additional information, see [“References to SQL labels” on page 2210.](#)

CASE

Begins a *case-expression*.

simple-when-clause

The value of the *expression* prior to the first WHEN keyword is tested for equality with the value of the *expression* that follows each WHEN keyword. If the comparison is true, the statements in the associated THEN clause are executed and processing of the CASE statement ends. If the result is unknown or false, processing continues to the next comparison. If the result does not match any of the comparisons, and an ELSE clause is present, the statements in the ELSE clause are executed.

searched-when-clause

The *search-condition* following the WHEN keyword is evaluated. If it evaluates to true, the statements in the associated THEN clause are executed and processing of the CASE statement ends. If it evaluates to false, or unknown, the next *search-condition* is evaluated. If no *search-condition* evaluates to true and an ELSE clause is present, the statements in the ELSE clause are executed.

When *searched-when-clause* is used, *search-condition* cannot contain a *fullselect*.

SQL-procedure-statement

Specifies a statement to execute. See [“SQL-procedure-statement \(SQL PL\)” on page 2212.](#)

search-condition

Specifies a condition that is true, false, or unknown about a row or group of table data.

ELSE SQL-procedure-statement

If none of the conditions specified in the *simple-when-clause* or *searched-when-clause* are true, the statements specified in *SQL-procedure-statement* are executed.

If none of the conditions specified in the WHEN clauses are true and an ELSE is not specified, an error is issued when the statement executes, and the execution of the CASE statement is terminated.

END CASE

Ends a *case-statement*.

Examples

Example 1: Use a simple case statement WHEN clause to update column DEPTNAME in table DEPT, depending on the value of SQL variable *v_workdept*.

```
CASE v_workdept
  WHEN 'A00'
    THEN UPDATE DEPT SET
      DEPTNAME = 'DATA ACCESS 1';
  WHEN 'B01'
    THEN UPDATE DEPT SET
      DEPTNAME = 'DATA ACCESS 2';
  ELSE UPDATE DEPT SET
      DEPTNAME = 'DATA ACCESS 3';
END CASE
```

Example 2: Use a searched case statement WHEN clause to update column DEPTNAME in table DEPT, depending on the value of SQL variable *v_workdept*.

```
CASE
  WHEN v_workdept < 'B01'
    THEN UPDATE DEPT SET
      DEPTNAME = 'DATA ACCESS 1';
  WHEN v_workdept < 'C01'
    THEN UPDATE DEPT SET
      DEPTNAME = 'DATA ACCESS 2';
  ELSE UPDATE DEPT SET
```



```
DEPTNAME = 'DATA ACCESS 3';
END CASE
```

compound-statement

A compound statement groups other statements together in an SQL routine or advanced trigger. A compound statement allows the declaration of SQL variables, cursors, and condition handlers.

Syntax

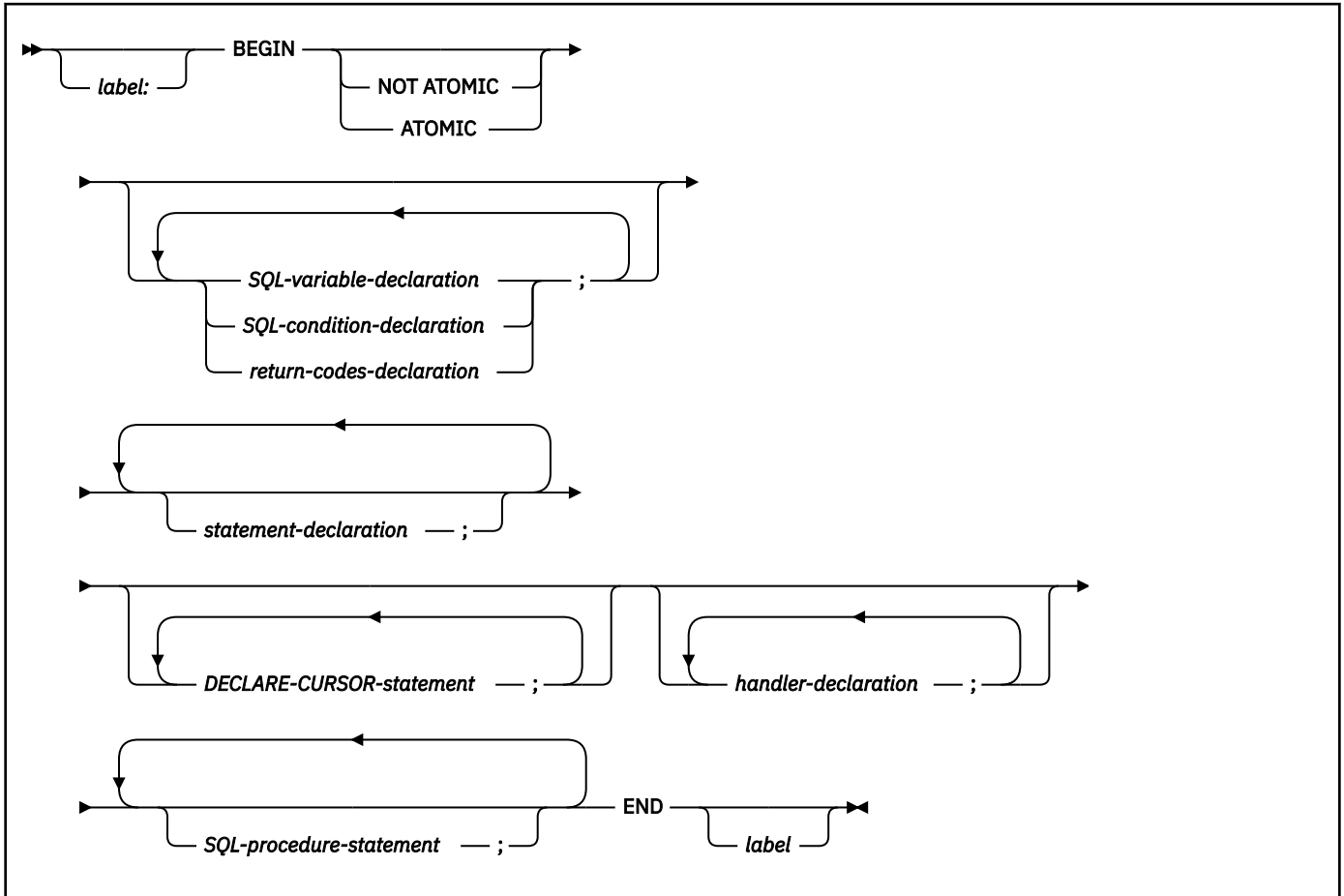

SQL-variable-declaration:

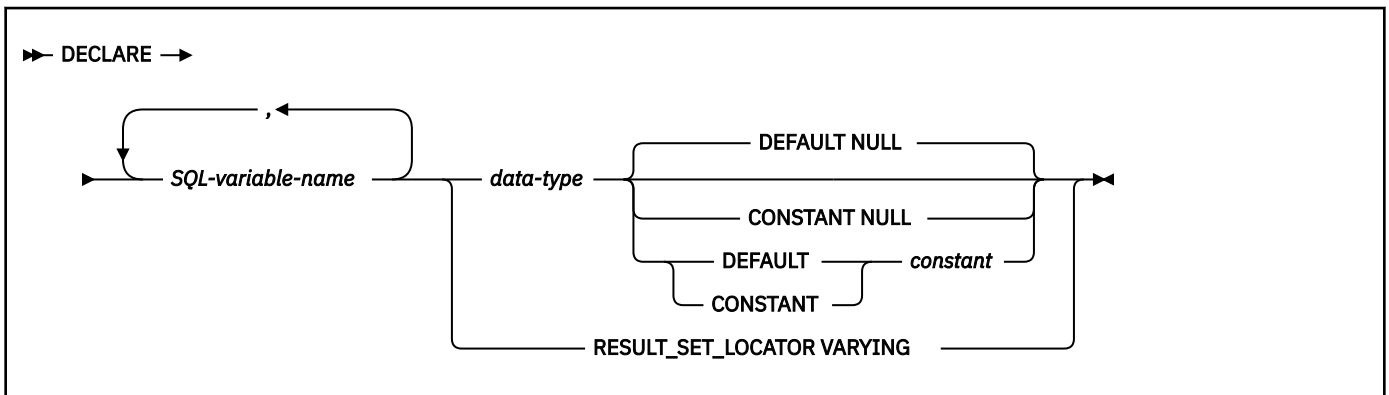

SQL-condition-declaration:

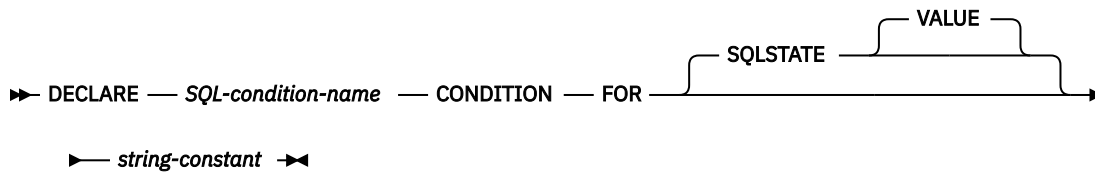

return-codes-declaration:

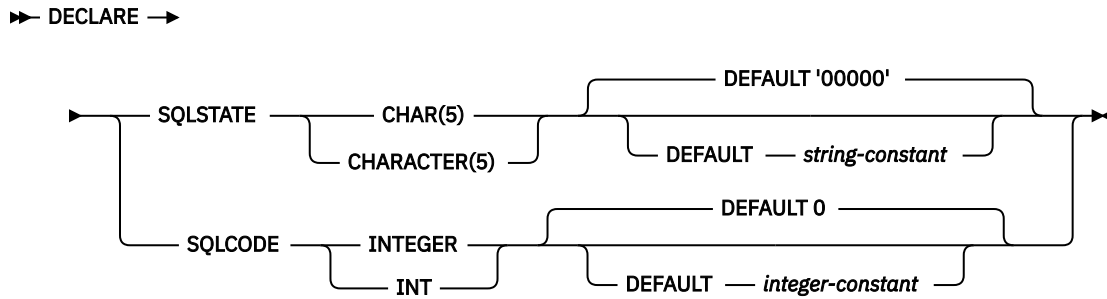

statement-declaration:

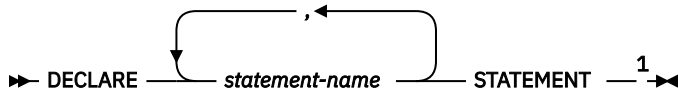

Notes:

¹ The statement is not allowed in an *SQL-routine-body* for an SQL function.

handler-declaration:

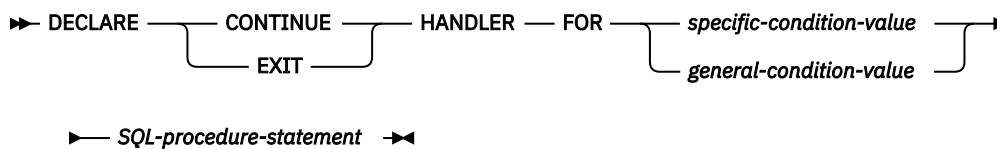

specific-condition-value:

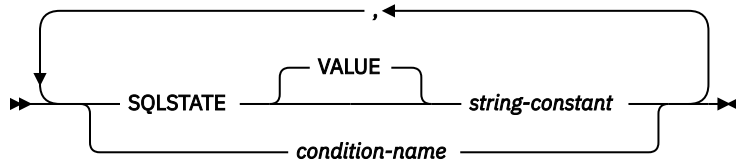

general-condition-value:



Description

label

Specifies the label for the compound-statement. If the beginning label is specified, it can be used to qualify SQL variables declared in the compound statement and can also be specified as the target on a LEAVE statement. If the ending label is specified, it must be the same as beginning label. The label name cannot be the same as the routine name, trigger name, or another label within the same scope.

ATOMIC or NOT ATOMIC

Specifies whether an unhandled exception condition within a compound-statement causes that compound statement to be rolled back. The default for the outermost compound statement in an advanced trigger is ATOMIC; otherwise the default is NOT ATOMIC.

ATOMIC

ATOMIC indicates that an unhandled exception condition within the compound-statement causes the compound-statement to be rolled back. ATOMIC must not be specified in a compound statement in an SQL scalar function, in an SQL procedure, or in a compound statement that is nested within another compound statement that is defined as ATOMIC.

NOT ATOMIC

NOT ATOMIC indicates that an unhandled exception condition within the compound-statement does not cause the compound-statement to be rolled back. NOT ATOMIC must not be specified in the outermost compound statement of an advanced trigger.

SQL-variable-declaration

Declares a variable that is local to the compound statement.

SQL-variable-name

Defines the name of a variable. Db2 converts all SBCS SQL variable names that are not delimited to uppercase. *SQL-variable-name* must be unique within the compound statement in which it is declared, excluding any declarations in compound statements that are nested within that compound statement. *SQL-variable-name* must not be the same as a parameter name. See [“References to SQL parameters and variables in SQL PL”](#) on page 2208 for information about how SQL variable names are resolved when there are columns with the same name as an SQL variable involved in a statement, or when multiple SQL variables exist with the same name in the routine body.

SQL-variable-name can only be referenced within the compound statement in which it is declared, including any compound statement that is nested within that compound statement. If the compound statement where the variable is declared has a label, references to the variable name can be qualified with that label. For example, an SQL variable V that is declared in a compound statement that is labeled C can be referenced as C.V.

data-type

Specifies the data type and length of the variable. SQL variables follow the same rules for default lengths and maximum lengths as SQL routine parameters. See [“CREATE FUNCTION statement \(compiled SQL scalar function\)”](#) on page 1428 for descriptions of SQL data types and lengths.

DEFAULT or CONSTANT

Specifies a value for the SQL variable when the compound statement in which it is declared is entered. If neither DEFAULT nor CONSTANT is specified, the default for the SQL variable is the null value. Only DEFAULT NULL can be explicitly specified if *array-type-name* is specified. Only DEFAULT NULL or CONSTANT NULL can be specified for an SQL variable with the XML data type.

DEFAULT

Defines the default for the SQL variable. The specified constant must represent a value that could be assigned to the variable in accordance with the rules of assignment as described in [“Assignment and comparison” on page 143](#).

CONSTANT

Specifies that the SQL variable has a fixed value that cannot be changed. An SQL variable that is defined using CONSTANT cannot be used as the target of any assignment operation. The specified constant must represent a value that could be assigned to the variable in accordance with the rules of assignment as described in [“Assignment and comparison” on page 143](#).

Variables that are named SQLCODE and SQLSTATE cannot be defined using CONSTANT.

NULL

Specifies NULL as the default for the SQL variable.

constant

Specifies a constant as the default for the SQL variable.

RESULT_SET_LOCATOR VARYING

Specifies the data type for a result set locator variable.

SQL-condition-declaration

Declares a condition name and corresponding SQLSTATE value.

SQL-condition-name

Specifies the name of the condition. The condition name must be unique within the compound statement in which it is declared, excluding any declarations that are in compound statements that are nested within that compound statement. A condition name can only be referenced within the compound statement in which it is declared, including any compound statements that are nested within that compound statement.

FOR SQLSTATE *string-constant*

Specifies the SQLSTATE that is associated with the condition. The string must be specified as five characters enclosed in single quotes, and the SQLSTATE class (the first two characters) must not be '00'.

return-codes-declaration

Declares special variables named SQLSTATE and SQLCODE. These variables are automatically set to the SQLSTATE and SQLCODE values for the first condition in the diagnostics area after executing an SQL statement other than GET DIAGNOSTICS or an empty compound statement.

The SQLSTATE and SQLCODE SQL variables are only intended to be used as a means of obtaining the SQL return codes that resulted from processing the previous SQL statement other than GET DIAGNOSTICS. If there is any intention to use the SQLSTATE and SQLCODE values, save the values immediately to other SQL variables to avoid having the values replaced by the SQL return codes returned after executing the next SQL statement. If a handler is defined that handles an SQLSTATE, you can use an assignment statement to save that SQLSTATE (or the associated SQLCODE) value in another SQL variable, if the assignment is the first statement in the handler.

Assignment to these variables is not prohibited; however, it is not recommended. Assignment to these variables is ignored by condition handlers, and processing an assignment to these special variables causes the specified values for the assignment to be overlaid with the SQL return codes returned from executing the statement that does the assignment. The SQLSTATE and SQLCODE SQL variables cannot be set to NULL.

statement-declaration

Declares a list of one or more names that are local to the compound statement. A statement name cannot be the same as another statement name within the same compound statement.

DECLARE-CURSOR-statement

Declares a cursor in the procedure body. Each cursor must have a unique name within the routine. The cursor can only be referenced from within the compound statement in which it is declared, including any compound statements that are nested within that compound statement. Use an OPEN statement

to open the cursor, a FETCH statement to read a row using the cursor, and a CLOSE statement to close the cursor. If the cursor is intended for use as a result set cursor:

- Specify WITH RETURN when the cursor is declared
- Create the procedure using the DYNAMIC RESULT SETS clause with a non-zero value
- Do not specify a CLOSE statement for the cursor in the compound statement

For additional information about declaring a cursor, see [“DECLARE CURSOR statement”](#) on page 1819.

handler-declaration

Specifies a condition handler, an *SQL-procedure-statement* to execute when an exception or completion condition occurs in the compound-statement. The *SQL-procedure-statement* executes when a condition handler receives control.

A condition handler declaration cannot reference the same condition value or SQLSTATE value more than one time. It cannot reference an SQLSTATE value and a condition name that represent the same SQLSTATE value.

When two or more condition handlers are declared in a compound statement, no two condition handler declarations can specify the same:

- general condition category
- specific condition, either as an SQLSTATE value or as a condition name that represents the same value

A condition handler is active for the set of *SQL-procedure-statements* that follow the condition handler declarations within the compound statement in which the condition handler is declared, including any nested compound statements.

CONTINUE

Specifies that after the condition handler is activated and completes successfully, control is returned to the SQL statement that follows the statement that raised the condition. However, if the condition is an error condition and it was encountered while evaluating a search condition, as in a CASE, FOR, IF, REPEAT or WHILE statement, control returns to the statement that follows the corresponding END CASE, END FOR, END IF, END REPEAT, or END WHILE.

EXIT

Specifies that after the condition handler is activated and completes successfully, control is returned to the end of the compound statement that declared the condition handler.

The conditions that can cause the handler to gain control are:

SQLSTATE string-constant

Specifies that the handler is invoked when the specific SQLSTATE occurs. The first two characters of the SQLSTATE value must not be '00'.

SQL-condition-name

Specifies that the handler is invoked when the specific SQLSTATE that is associated with the condition name occurs. The *SQL-condition-name* must be declared within the compound statement that contains the handler declarations, or within a compound statement in which that compound statement is nested.

SQLEXCEPTION

Specifies that the handler is invoked when an SQLEXCEPTION occurs. An SQLEXCEPTION is an SQLSTATE in which the class code is a value other than '00', '01', or '02'. For more information on SQLSTATE values, see [SQLSTATE values and common error codes \(Db2 Codes\)](#).

SQLWARNING

Specifies that the handler is invoked when an SQLWARNING occurs. An SQLWARNING is an SQLSTATE value with a class code of '01'.

NOT FOUND

Specifies that the handler is invoked when a NOT FOUND condition occurs. NOT FOUND corresponds to an SQLSTATE value with a class code of '02'.

Notes

Unlike host variables, SQL variables are not preceded by colons when they are used in SQL statements.

Nesting compound statements: Compound statements can be nested. Nested compound statements can be used to scope variable definitions, condition names, condition handlers, and cursors to a subset of the statements in a routine. This can simplify the processing that is done for each SQL routine statement. Nested compound statements enable the use of a compound statement within the declaration of a condition handler.

The scope of a cursor: The scope of a cursor name is the compound statement in which it is declared, including any compound statements that are nested within that compound statement. A cursor name can only be referenced within the compound statement in which it is declared, including any compound statements that are nested within that compound statement.

Considerations for statement-name: The scope of a *statement-name* that is declared in a compound statement is the compound statement and any nested compound statements (unless the same *statement-name* is declared in a nested compound statement). If a *statement-name* is used in a DECLARE CURSOR statement or a PREPARE statement and has not been declared in the compound statement where it is used or any outer compound statements in which it is nested, the *statement-name* is assumed to be declared globally for the routine.

Condition handlers: Condition handlers in SQL routines and advanced triggers are similar to WHENEVER statements that are used in external SQL application programs. A condition handler can be defined to automatically get control when an exception, warning, or not found condition occurs. The body of a condition handler contains code that is executed when the condition handler is activated. A condition handler can be activated as the result of an exception, a warning, or a not found condition that is returned by Db2 for the processing of an SQL statement. Or the condition that activates the handler can be the result of a SIGNAL or RESIGNAL statement that is issued within the SQL routine or trigger body.

A condition handler is declared within a compound statement, and it is active for the set of *SQL-procedure-statements* that follow all of the condition handler declarations within the compound statement in which the condition handler is declared. For example, the scope of a condition handler declaration H is the list of *SQL-procedure-statements* that follow the condition handler declarations that are contained within the compound statement in which H appears. This means that the scope of H does not include the statements that are contained in the body of the condition handler H, implying that a condition handler cannot handle conditions that arise inside its own body. Similarly, for any two condition handlers H1 and H2 that are declared in the same compound statement, H1 will not handle conditions that arise in the body of H2, and H2 will not handle conditions that arise in the body of H1.

The declaration of a condition handler specifies the condition that activates it, the type of condition handler (CONTINUE or EXIT), and the handler action. The type of condition handler determines to where control is returned after the handler action successfully completes.

Condition handler activation: When a condition other than a successful completion occurs in the processing of *SQL-procedure-statement*, if a condition handler that could handle the condition is within scope, one such condition handler will be activated to process the condition.

In a routine with nested compound statements, condition handlers that could handle a specific condition might exist at several levels of the nested compound statements. The condition handler that is activated is a condition handler that is declared innermost to the scope in which the condition was encountered. If more than one condition handler at the nesting level could handle the condition, the condition handler that is activated is the most appropriate handler that is declared in that compound statement.

The most appropriate handler is the condition handler that most closely matches the SQLSTATE or the exception or completion condition. For a given compound statement, when both a specific handler for a condition and a general handler are declared that address the same condition, the specific handler takes precedence over the general handler.

For example, if the innermost compound statement declares a specific handler for SQLSTATE '22001', as well as a general handler for SQLEXCEPTION, the specific handler for SQLSTATE '22001' is the most appropriate handler when SQLSTATE '22001' is encountered. In this case, the specific handler is activated.

When a condition handler is activated, the condition handler action is executed. If the handler action completes successfully or with an unhandled warning, the diagnostics area is cleared, and the type of the condition handler (CONTINUE or EXIT handler) determines to where control is returned. Additionally, the SQLSTATE and SQLCODE SQL variables are cleared when a handler completes successfully or with an unhandled warning.

If the handler action does not complete successfully and an appropriate handler exists for the condition that is encountered in the handler action, that condition handler is activated. Otherwise, the condition that is encountered within the condition handler is unhandled.

Unhandled conditions: If a condition is encountered and an appropriate handler does not exist for that condition, the condition is unhandled.

- If the unhandled condition is an exception, the SQL routine or advanced trigger that contains the failing statement is terminated with an unhandled exception condition.
- If the unhandled condition is a warning or is a not found condition, processing continues with the next statement. Note that the processing of the next SQL statement will cause information about the unhandled condition in the diagnostics area to be overwritten, and evidence of the unhandled condition will no longer exist.

If an SQL routine or advanced trigger completes with an unhandled warning or not found condition, the condition is returned to the invoking statement. If a basic trigger completes with an unhandled warning or not found condition, the condition is not returned to the invoking statement.

Considerations for using SIGNAL and RESIGNAL statements with nested compound statements: If an SQL-procedure-statement that is specified in the condition handler is either a SIGNAL or RESIGNAL statement with an exception SQLSTATE, the compound statement terminates with the specified exception. This happens even when this condition handler or another condition handler in the same compound statement specifies CONTINUE, since these condition handlers are not in the scope of this exception. If a compound statement is nested in another compound statement, condition handlers in the higher level compound statement can handle the exception because those condition handlers are within the scope of the exception.

SQLSTATE and SQLCODE variables in SQL routines and advanced triggers: To help debug your SQL routines and advanced triggers, you might find it useful to check the SQLSTATE and SQLCODE value after executing a statement. An SQLCODE or SQLSTATE variable can be declared and subsequently referenced in an SQL routine or advanced trigger. You could insert the value of the SQLCODE and SQLSTATE into a table at various points in the SQL routine or advanced trigger, or return the SQLCODE and SQLSTATE values in a diagnostics string as an OUT parameter for an SQL procedure. To use the SQLCODE and SQLSTATE values, you must declare the following SQL variables in the SQL routine or advanced trigger body:

When you reference the SQLCODE or SQLSTATE variables in an SQL routine or advanced trigger, Db2 sets the value of SQLCODE to 0 and SQLSTATE to '00000' for the subsequent statement. You can also use CONTINUE condition handlers to assign the value of the SQLSTATE and SQLCODE variables to variables in your SQL routine or advanced trigger body. You can then use these SQL variables to control your routine or trigger logic, or pass the value back as an output parameter. In the following example, the SQL routine returns control to the statement following each SQL statement with the SQLCODE set in a SQL variable called RETCODE:

```
DECLARE SQLCODE INTEGER DEFAULT 0;
DECLARE retcode INTEGER DEFAULT 0;
DECLARE CONTINUE HANDLER FOR SQLEXCEPTION SET retcode = SQLCODE;
DECLARE CONTINUE HANDLER FOR SQLWARNING SET retcode = SQLCODE;
DECLARE CONTINUE HANDLER FOR NOT FOUND SET retcode = SQLCODE;
```

The compound statement itself does not affect the SQLSTATE and SQLCODE SQL variables. However, SQL statements contained within the compound statement can affect the SQLSTATE and SQLCODE SQL variables. At the end of the compound statement, the SQLSTATE and SQLCODE SQL variables reflect the result of the last SQL statement executed within the compound statement that caused a change to the SQLSTATE and SQLCODE SQL variables. If the SQLSTATE and SQLCODE SQL variables were not changed

within the compound statement, they contain the same values as when the compound statement was entered.

Null values in SQL parameters and SQL variables: If the value of an SQL parameter or SQL variable is null and it is used in an SQL statement that does not allow an indicator variable, an error is returned.

Effect on open cursors: At the end of the compound statement, all open cursors that are declared in that compound statement, except cursors that are used to return result sets, are closed.

Atomic processing of a compound statement: Atomic processing is not supported for a compound statement. If atomic behavior is needed for a block of code in a compound statement, set a savepoint before the nested compound statement is entered. This will allow changes to be undone with a ROLLBACK TO SAVEPOINT statement.

Examples

Example 1: Create a procedure body with a compound statement that performs the following actions:

1. Declares SQL variables.
2. Declares a cursor to return the salary of employees in a department determined by an IN parameter.
3. Declares an EXIT handler for the condition NOT FOUND (end of file). The SQL procedure statement of the handler assigns the value 6666 to the OUT parameter *medianSalary*.
4. Selects the number of employees in the given department into the SQL variable *v_numRecords*.
5. Fetches rows from the cursor in a WHILE loop until the salary records for 50% + 1 of the employees in the department have been retrieved.
6. Returns the median salary.

```
CREATE PROCEDURE DEPT_MEDIAN
  (IN deptNumber SMALLINT,
   OUT medianSalary DOUBLE)
LANGUAGE SQL
BEGIN
  DECLARE v_numRecords INTEGER DEFAULT 1;
  DECLARE v_counter INTEGER DEFAULT 0;
  DECLARE c1 CURSOR FOR
    SELECT salary FROM staff
      WHERE DEPT = deptNumber
      ORDER BY salary;
  DECLARE EXIT HANDLER FOR NOT FOUND
    SET medianSalary = 6666;

  /* initialize OUT parameter */
  SET medianSalary = 0;
  SELECT COUNT(*) INTO v_numRecords FROM staff
    WHERE DEPT = deptNumber;
  OPEN c1;
  WHILE v_counter < (v_numRecords / 2 + 1) DO
    FETCH c1 INTO medianSalary;
    SET v_counter = v_counter + 1;
  END WHILE;
  CLOSE c1;
END
```

Example 2: Define an exit handler for any error, warning, or case of end of data. When this procedure is invoked successfully, the value 45000 is returned for the output parameter:

```
CREATE PROCEDURE JMBLIB.PROCL(OUT MEDIANSALARY INT)
LANGUAGE SQL
BEGIN
  DECLARE CHAR1 CHAR;
  DECLARE C1 CURSOR FOR SELECT *
    FROM SYSIBM.SYSDUMMY1;
  DECLARE EXIT HANDLER FOR NOT FOUND,
    SQLEXCEPTION,
    SQLWARNING
    RETURN;
  OPEN C1;
  FETCH C1 INTO CHAR1;
  SET MEDIANSALARY = 45000;
  FETCH C1 INTO CHAR1;
```



```
SET MEDIAN_SALARY = 50000;  
END
```

FOR statement

The FOR statement executes a statement for each row of a table. An implicit compound statement is generated to implement the FOR statement.

Syntax

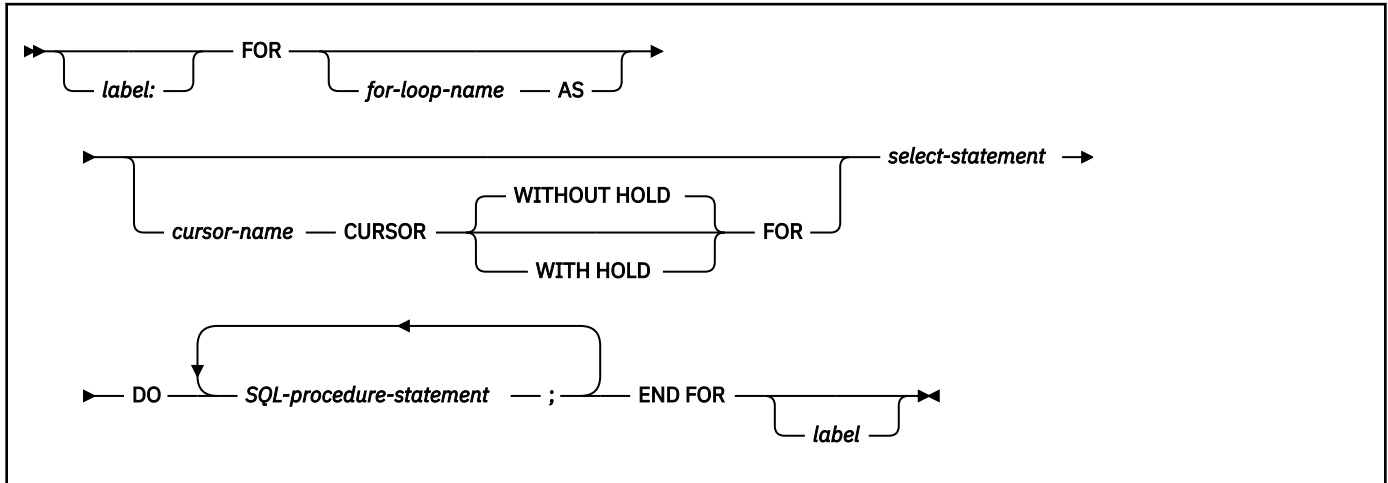

Description

label

Specifies the label for the FOR statement. If the ending label is specified, it must be the same as the beginning label. The label name cannot be the same as the routine name, advanced trigger name, or another label within the same scope. For more information, see [“References to SQL labels”](#) on page 2210.

for-loop-name

Specifies the label for the implicit compound statement that is generated to implement the FOR statement. *for-loop-name* follows the rules for the label of a compound statement except that it cannot be used with an ITERATE, GOTO, or LEAVE statement within the FOR statement. *for-loop-name* must not be the same as any label within the same scope.

for-loop-name can be used to qualify generated SQL variables that correspond to the columns that are returned by *select-statement*.

cursor-name

Names a cursor that is generated to select rows from the result table of *select-statement*. If *cursor-name* is not specified, a unique cursor name is generated.

cursor-name cannot be referenced outside of the FOR statement and cannot be specified on an OPEN, FETCH, or CLOSE statement.

WITH HOLD or **WITHOUT HOLD**

Specifies whether the cursor should be prevented from being closed as a consequence of a commit operation.

WITHOUT HOLD

Specifies that the cursor is not prevented from being closed as a consequence of a commit operation. WITHOUT HOLD is the default.

WITH HOLD

Specifies that the cursor should not be closed as a consequence of a commit operation. A cursor that is declared using the WITH HOLD clause is implicitly closed at commit time only if the

connection that is associated with the cursor is ended during the commit operation. For more information, see [“DECLARE CURSOR statement” on page 1819](#).

select-statement

Specifies the select statement of the cursor. Each expression in the SELECT list must have a name. If an expression is not a simple column name, the AS clause must be used to name the expression. If the AS clause is specified, that name is used for the variable and must be unique.

select-statement must not include a *values-clause*.

The SELECT list must not include an untyped array value.

SQL-procedure-statement

Specifies the SQL statements to be executed for each row of the table. The SQL statements must not include an OPEN, FETCH, or CLOSE statement that specifies the cursor name of the FOR statement.

Notes

FOR statement rules: The FOR statement executes one or multiple statements for each row in the result table of the cursor. The cursor is defined by specifying a SELECT list that describes the columns and rows selected. The statements within the FOR statement are executed for each row selected.

The SELECT list must consist of unique column names, and the objects referenced in the *select-statement* must exist at the current server when the routine or trigger is created. If the FOR statement is contained in a routine or trigger that is defined with the WITH EXPLAIN attribute, the PLAN_TABLE must exist when the routine or trigger is created.

The cursor specified in a FOR statement cannot be referenced outside the FOR statement and cannot be specified on an OPEN, FETCH, or CLOSE statement.

Handler warning: Handlers can be used to handle errors that might occur on the open of the cursor or fetch of a row using the cursor in the FOR statement. Handlers defined to handle these open or fetch conditions should not be CONTINUE handlers as they might cause the FOR statement to loop indefinitely.

Examples

In the following example, the FOR statement is used to specify a cursor that selects three columns from the employee table. For every row selected, SQL variable *fullname* is set to the last name followed by a comma, the first name, a blank, and the middle initial. Each value for *fullname* is inserted into table TNAMES.

```
BEGIN
  DECLARE fullname CHAR(40);
  FOR v1 AS
    c1 CURSOR FOR
    SELECT firstname, midinit, lastname FROM employee
  DO
    SET fullname =
      lastname CONCAT ', '
      CONCAT firstname
      CONCAT ' '
      CONCAT midinit;
    INSERT INTO TNAMES VALUES ( fullname );
  END FOR;
END;
```

GET DIAGNOSTICS statement

The GET DIAGNOSTICS statement obtains information about the previous SQL statement that was executed.

See [“GET DIAGNOSTICS statement” on page 1949](#).

When you need to specify a variable in a GET DIAGNOSTICS statement that is used within an SQL routine, you would use either *SQL-variable-name* or *SQL-parameter-name*. In an embedded GET DIAGNOSTICS statement, you would use a *host-variable*. You can replace the instances of *host-variable* in the

description of [“GET DIAGNOSTICS statement”](#) on page 1949 with *SQL-variable-name* or *SQL-parameter-name*.

Effects of the statement: The GET DIAGNOSTICS statement does not change the contents of the diagnostics area except for DB2_GET_DIAGNOSTICS_DIAGNOSTICS.

Considerations for the SQLSTATE and SQLCODE SQL variables: The GET DIAGNOSTICS statement does not change the value of the SQLSTATE and SQLCODE SQL variables.

The stacked diagnostics area: The stacked diagnostics area is only available within a handler in a native SQL procedure and non-inline SQL functions.

GOTO statement

Syntax



Description

label

Specifies the label for the GOTO statement. The label name cannot be the same as the routine name or advanced trigger name in which the label is used or another label in the same scope.

target-label

Specifies a label of the statement where processing is to continue. *target-label* must be defined as a label for an SQL procedure statement. The target label must be accessible to the GOTO statement as defined in [“References to SQL labels”](#) on page 2210, subject to the following restrictions:

- If the GOTO statement is in a condition handler, *target-label* must be defined in that condition handler.
- If the GOTO statement is not defined in a condition handler, *target-label* must not be defined in a condition handler.

Notes

Using a GOTO statement: It is recommended that the GOTO statement be used sparingly. This statement interferes with the normal sequence of processing SQL statements, thus making a routine more difficult to read and maintain. Before using a GOTO statement, determine whether another statement, such as IF or LEAVE, can be used in place, to eliminate the need for a GOTO statement.

Effect on open cursors: When a GOTO statement transfers control out of a compound statement, all open cursors that are declared in the compound statement that contains the GOTO statement are closed, except cursors that are used to return result sets.

Examples

Example 1: In the following procedure, the GOTO statement branches outside of the current compound statement to a higher level:

```
CREATE PROCEDURE TESTGOT05 ( )  
P1: BEGIN  
  DECLARE I ,A INTEGER;  
  SET I = 1;  
  LAB1: SET A = 1;  
  BEGIN  
    LAB2: SET A = 2;  
    BEGIN  
      SET I = I+1;  
      IF I<3 THEN GOTO LAB1;
```

```

        END IF;
      END;
    END;
  END P1

```

Example 2: In the following example, cursors are declared at multiple levels. The GOTO statement that specified TargLabel as the target label, results in the closing of cursors C1, C2, and C3. This is because cursors C1, C2, and C3 are all declared directly or indirectly in the compound statement with the label L1. The GOTO statement causes control to transfer out of the compound statement with label L1, so the cursors that are defined within that compound statement (at any level) are closed.

```

L0: BEGIN
  DECLARE CURSOR C0 ...
  ...
  TARGLABEL: ...
  ...
  L1: BEGIN
    DECLARE CURSOR C1 ...
    ...
    L2: BEGIN
      DECLARE CURSOR C2 ...
      ...
      GOTO TARGLABEL;
      ...
      L3: BEGIN
        DECALUE CURSOR C3 ...
        ...
      END L3;
    END L2;
  END L1;
END L0

```

IF statement

The IF statement executes different sets of SQL statements based on the result of search conditions.

Syntax

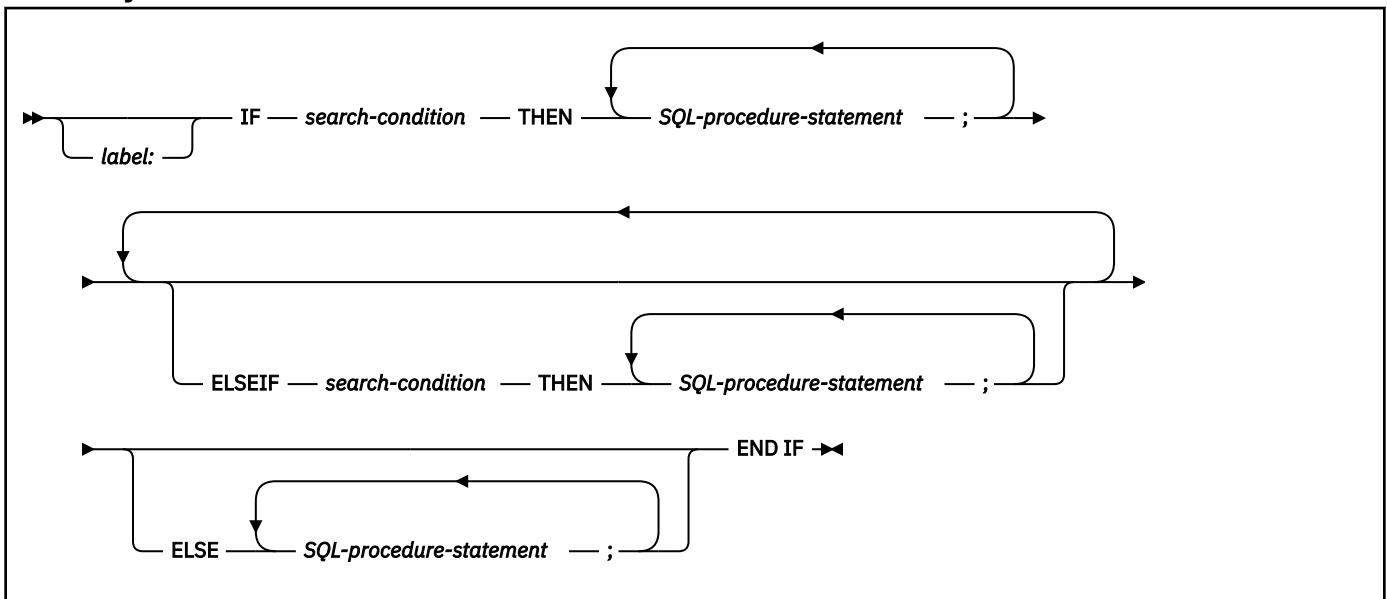

Description

label

Specifies the label for the IF statement. The label name cannot be the same as the routine name, advanced trigger name, or another label name within the same scope. For additional information, see [“References to SQL labels”](#) on page 2210.

search-condition

Specifies the *search-condition* for which an SQL statement should be executed. If the condition is unknown or false, processing continues to the next search condition, until either a condition is true or processing reaches the ELSE clause.

SQL-procedure-statement

Specifies an SQL statement to be executed if the preceding *search-condition* is true. See [“SQL-procedure-statement \(SQL PL\)”](#) on page 2212.

Examples

Assign a value to the SQL variable *new_salary* based on the value of SQL variable *rating*.

```
IF rating = 1
  THEN SET new_salary =
    new_salary + (new_salary * .10);
ELSEIF rating = 2
  THEN SET new_salary =
    new_salary + (new_salary * .05);
ELSE SET new_salary =
    new_salary + (new_salary * .02);
END IF;
```

ITERATE statement

The ITERATE statement causes the flow of control to return to the beginning of a labeled loop.

Syntax



Description

label

Specifies the label for the ITERATE statement. The label name cannot be the same as the routine name, advanced trigger name, or another label within the same scope. For additional information, see [“References to SQL labels”](#) on page 2210.

target-label

Specifies the label of the FOR, LOOP, REPEAT, or WHILE statement to which the flow of control is passed. *target-label* must be defined as a label for a FOR, LOOP, REPEAT, or WHILE statement. The ITERATE statement must be in that FOR, LOOP, REPEAT, or WHILE statement, or in the block of code that is directly or indirectly nested within that statement, subject to the following restrictions:

- If the ITERATE statement is in a condition handler, *target-label* must be defined in that condition handler.
- If the ITERATE statement is not in a condition handler, *target-label* must not be defined in a condition handler.

Examples

Example 1: This example uses a cursor to return information for a new department. If the *not_found* condition handler is invoked, the flow of control passes out of the loop. If the value of *v_dept* is 'D11', an ITERATE statement causes the flow of control to be passed back to the top of the LOOP statement. Otherwise, a new row is inserted into the table.

```
CREATE PROCEDURE ITERATOR ()
  LANGUAGE SQL
  MODIFIES SQL DATA
  BEGIN
```

```

DECLARE v_dept CHAR(3);
DECLARE v_deptname VARCHAR(29);
DECLARE v_admdept CHAR(3);
DECLARE at_end INTEGER DEFAULT 0;
DECLARE not_found CONDITION FOR SQLSTATE '02000';
DECLARE c1 CURSOR FOR
    SELECT deptno,deptname,admdept
    FROM department
    ORDER BY deptno;
DECLARE CONTINUE HANDLER FOR not_found
    SET at_end = 1;
OPEN c1;
ins_loop:
LOOP
    FETCH c1 INTO v_dept, v_deptname, v_admdept;
    IF at_end = 1 THEN
        LEAVE ins_loop;
    ELSEIF v_dept = 'D11' THEN
        ITERATE ins_loop;
    END IF;
    INSERT INTO department (deptno,deptname,admdept)
        VALUES('NEW', v_deptname, v_admdept);
END LOOP;
CLOSE c1;
END

```

Example 2: An ITERATE statement can be issued from a nested block to cause that flow of control to return to the beginning of a loop at a higher level. In the following example, the ITERATE statement within the LAB2 compound statement causes the flow of control to return to the beginning of the LAB1 LOOP statement:

```

LAB1: LOOP
    SET A = 0;
    LAB2: BEGIN
        ...
        LAB3: BEGIN
            ...
            ITERATE LAB1; -- Multilevel ITERATE
            ...
        END LAB3;
        ...
        ITERATE LAB1; -- Multilevel ITERATE
        ...
    END LAB2;
END LOOP;S

```

LEAVE statement

The LEAVE statement transfers program control out of a FOR, LOOP, REPEAT, WHILE, or compound statement.

Syntax



Description

label

Specifies the label for the LEAVE statement. The label name cannot be the same as the routine name, advanced trigger name, or the same as another label that is within the same scope. For additional information, see [“References to SQL labels”](#) on page 2210.

target-label

Specifies the label of the compound, FOR, LOOP, REPEAT, or WHILE statement to exit. *target-label* must be defined as a label for a compound, FOR, LOOP, REPEAT, or WHILE statement, or in a block of code that is directly or indirectly nested within that statement, subject to the following rules:

- If the LEAVE statement is in a condition handler, *target-label* must be defined in that condition handler.
- If the LEAVE statement is not in a condition handler, *target-label* must not be defined in a condition handler.

Notes

Effect on open cursors: When a LEAVE statement transfers control out of a compound statement, all open cursors in the compound statement, except cursors that are used to return result sets, are closed.

Examples

Example 1: The example contains a loop that fetches data for cursor c1. If the value of SQL variable *at_end* is not zero, the LEAVE statement transfers control out of the loop.

```
CREATE PROCEDURE LEAVE_LOOP (OUT COUNTER INTEGER)
LANGUAGE SQL
BEGIN
  DECLARE v_counter INTEGER;
  DECLARE v_firstname VARCHAR(12);
  DECLARE v_midinit CHAR(1);
  DECLARE v_lastname VARCHAR(15);
  DECLARE at_end SMALLINT DEFAULT 0;
  DECLARE not_found CONDITION FOR SQLSTATE '02000';
  DECLARE c1 CURSOR FOR
    SELECT firstname, midinit, lastname
    FROM employee;
  DECLARE CONTINUE HANDLER FOR not_found
    SET at_end = 1;
  SET v_counter = 0;
  OPEN c1;
fetch_loop:
  LOOP
    FETCH c1 INTO v_firstname, v_midinit, v_lastname;
    IF at_end <> 0 THEN
      LEAVE fetch_loop;
    END IF;
    SET v_counter = v_counter + 1;
  END LOOP fetch_loop;
  SET counter = v_counter;
  CLOSE c1;
END
```

Example 2: A LEAVE statement can be issued from a nested block to leave a statement at a higher level. In the following example, the LEAVE statement within the LAB2 compound statement causes the LAB1 LOOP statement to terminate:

```
LAB1: LOOP
  ...
  LAB2: BEGIN
    SET A = 0;
    ...
    LAB3: BEGIN
      ...
      LEAVE LAB1; -- Multilevel LEAVE
      ...
    END LAB3;
    ...
    LEAVE LAB1; -- Multilevel LEAVE
    ...
  END LAB2;
END LOOP;S
```

LOOP statement

The LOOP statement executes a statement or group of statements multiple times.

Syntax

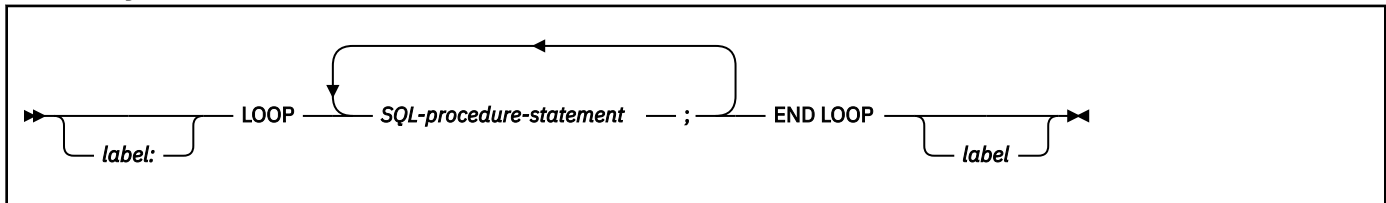

Description

label

Specifies the label for the LOOP statement. If the ending label is specified, a matching beginning label must be specified. A label name cannot be the same as the routine name, advanced trigger name, or another label within the same scope. For additional information, see [“References to SQL labels” on page 2210](#).

SQL-procedure-statement

Specifies an SQL statement to be executed in the loop. The statement must be one of the statements listed under [“SQL-procedure-statement \(SQL PL\)” on page 2212](#).

Notes

Considerations for the diagnostics area: At the beginning of the first iteration of the LOOP statement, and with every subsequent iteration, the diagnostics area is cleared.

Considerations for the *SQLSTATE* and *SQLCODE* SQL variables: Prior to executing the first SQL-procedure-statement within that LOOP statement, the *SQLSTATE* and *SQLCODE* values reflect the last values that were set prior to the LOOP statement. If the loop is terminated with a GOTO or a LEAVE statement, the *SQLSTATE* and *SQLCODE* values reflect successful completion of that statement. When the LOOP statement iterates, the *SQLSTATE* and *SQLCODE* values reflect the result of the last SQL statement that is executed within the LOOP statement.

Examples

This procedure uses a LOOP statement to fetch values from the employee table. Each time the loop iterates, the OUT parameter counter is incremented and the value of *v_midinit* is checked to ensure that the value is not a single space (' '). If *v_midinit* is a single space, the LEAVE statement passes the flow of control outside of the loop.

```
CREATE PROCEDURE LOOP_UNTIL_SPACE(OUT counter INTEGER)
LANGUAGE SQL
BEGIN
    DECLARE v_counter INTEGER DEFAULT 0;
    DECLARE v_firstnme VARCHAR(12);
    DECLARE v_midinit CHAR(1);
    DECLARE v_lastname VARCHAR(15);
    DECLARE c1 CURSOR FOR
        SELECT firstnme, midinit, lastname
        FROM employee;
    DECLARE EXIT HANDLER FOR NOT FOUND
        SET counter = -1;
    OPEN c1;
    fetch_loop:
    LOOP
        FETCH c1 INTO v_firstnme, v_midinit, v_lastname;
        IF v_midinit = ' ' THEN
            LEAVE fetch_loop;
        END IF;
        SET v_counter = v_counter + 1;
    END LOOP fetch_loop;
    SET counter = v_counter;
```



```
CLOSE c1;
END
```

REPEAT statement

The REPEAT statement executes a statement or group of statements until a search condition is true.

Syntax

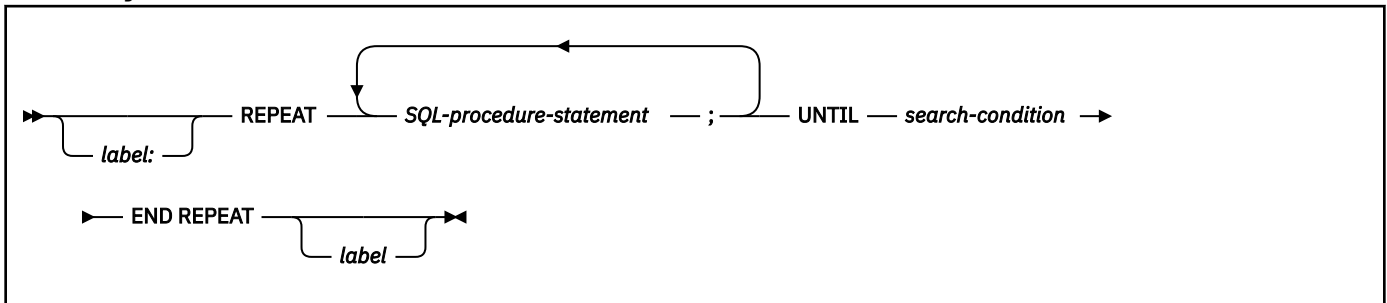

Description

label

Specifies the label for the REPEAT statement. If an ending label is specified, a matching beginning label must be specified. A label name cannot be the same as the routine name, advanced trigger name, or another label within the same scope. For additional information, see [“References to SQL labels”](#) on page 2210.

SQL-procedure-statement

Specifies an SQL statement to be executed within the REPEAT loop. The statement must be one of the statements listed under [“SQL-procedure-statement \(SQL PL\)”](#) on page 2212.

search-condition

Specifies a condition that is evaluated after each execution of the REPEAT loop. If the condition is true, the REPEAT loop will exit. If the condition is unknown or false, the looping continues.

Notes

Considerations for the diagnostics area: At the beginning of the first iteration of the REPEAT statement, and with every subsequent iteration, the diagnostics area is cleared.

Considerations for the SQLSTATE and SQLCODE SQL variables: At the beginning of the first iteration of the REPEAT statement, the SQLSTATE and SQLCODE values reflect the values that were set prior to the REPEAT statement. At the beginning of iterations 2 through n of the REPEAT statement, the SQLSTATE and SQLCODE SQL values reflect the result of evaluating the search condition in the UNTIL clause of that REPEAT. If the loop is terminated with a GOTO, ITERATE, or LEAVE statement, the SQLSTATE and SQLCODE values reflect the successful completion of that statement. Otherwise, after the END REPEAT of the REPEAT statement completes, the SQLSTATE and SQLCODE reflect the result of evaluating the search condition in the UNTIL clause of that REPEAT statement.

Examples

Use a REPEAT statement to fetch rows from a table.

```
fetch_loop:
REPEAT
  FETCH c1 INTO
  v_firstname, v_midinit, v_lastname;
UNTIL
  SQLCODE <> 0
END REPEAT fetch_loop
```

RESIGNAL statement

The RESIGNAL statement is used within a condition handler to resignal the condition that activated the handler, or to raise an alternate condition so that it can be processed at a higher level. It causes an exception, warning, or not found condition to be returned along with optional message text.

Syntax

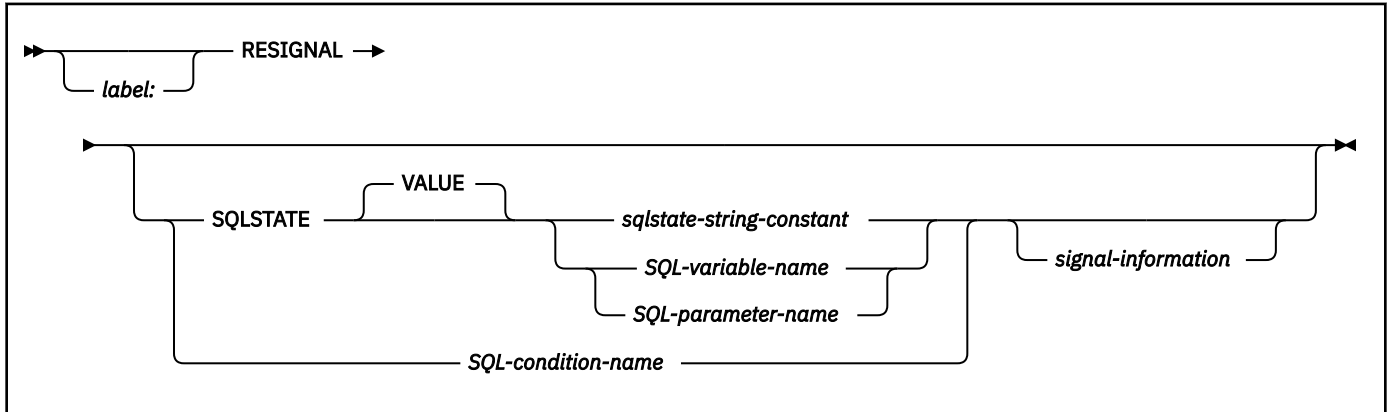

signal-information:

```
SET MESSAGE_TEXT = diagnostic-string-expression
```

Description

label

Specifies the label for the RESIGNAL statement. A label name cannot be the same as the routine name, advanced trigger name, or another label within the same scope. For additional information, see [“References to SQL labels”](#) on page 2210.

SQLSTATE VALUE

Specifies the SQLSTATE that will be returned. Any valid SQLSTATE value can be used. It must be a character string constant with exactly five characters that follow the rules for SQLSTATE values:

- Each character must be from the set of digits ('0' through '9') or non-accented upper case letter ('A' through 'Z').
- The SQLSTATE class (the first two characters) cannot be '00' because it represents successful completion.

If the SQLSTATE does not conform to these rules, an error occurs.

sqlstate-string-constant

A character string constant with an actual length of five bytes that is a valid SQLSTATE value.

SQL-variable-name or SQL-parameter-name

Specifies an SQL variable or SQL parameter that is defined for the routine.

SQL-variable-name

Specifies an SQL variable that is declared within the *compound-statement* that contains the RESIGNAL statement or within a compound statement in which that compound statement is nested. *SQL-variable-name* must be defined as CHAR or VARCHAR data type with an actual length of five bytes, must not be null, and must contain a valid SQLSTATE value.

SQL_parameter-name

Specifies an SQL parameter that is defined for the routine that contains the SQLSTATE value. The SQL parameter must be defined as CHAR or VARCHAR data type with an actual length of five bytes, must not be null, and must contain a valid SQLSTATE value.

SQL-condition-name

Specifies the name of the condition that will be returned. *SQL-condition-name* must be declared within the *compound-statement* that contains the RESIGNAL statement, or within a compound statement in which that compound statement is nested.

SET MESSAGE_TEXT

Specifies a string that describes the error or warning. The string is returned in the SQLERRMC field of the SQLCA or with the GET DIAGNOSTICS statement.

diagnostic-string-expression

An expression with a data type of CHAR or VARCHAR that returns a character string of up to 1000 bytes that describes the error or warning condition. For information on how to obtain the complete message text, see [“GET DIAGNOSTICS statement” on page 1949](#).

Notes

While any valid SQLSTATE value can be used in the RESIGNAL statement, programmers should define new SQLSTATEs based on ranges reserved for applications. This practice prevents the unintentional use of an SQLSTATE value that might be defined by the database manager in a future release.

If the SQLSTATE or condition indicates that an exception is signaled (SQLSTATE class other than '01' or '02'):

- If a condition handler exists in the same compound statement as the RESIGNAL statement, and the compound statement contains a condition handler for SQLEXCEPTION or the specified SQLSTATE or condition, the exception is handled and control is transferred to that condition handler.
- If the compound statement is nested and an outer level compound statement has a condition handler for SQLEXCEPTION or the specified SQLSTATE or condition, the exception is handled and control is transferred to that condition handler.
- Otherwise, the exception is not handled and control is immediately returned to the end of the compound statement.

If an SQLSTATE or a condition indicates that a warning or a not found condition is signaled:

- If a condition handler exists in the same compound statement as the RESIGNAL statement, and the compound statement contains a condition handler for SQLWARNING, NOT FOUND, or the specified SQLSTATE or condition, the warning or not found condition is handled and control is transferred to that condition handler.
- If the compound statement is nested and an outer level compound statement contains a condition handler for SQLWARNING, NOT FOUND, or the specified SQLSTATE or condition, the warning or not found condition is handled and control is returned to that condition handler.
- Otherwise, the warning is not handled and processing continues with the next statement.

Considerations for the diagnostics area: The RESIGNAL statement might modify the contents of the current diagnostics area. If an SQLSTATE or *condition-name* is specified as part of the RESIGNAL statement, the RESIGNAL statement starts with a clear diagnostics area and sets the RETURNED_SQLSTATE to reflect the specified SQLSTATE or *condition-name*. If message text is specified, the MESSAGE_TEXT item of the condition area is assigned the specified value. DB2_RETURNED_SQLCODE is set to +438 or -438 corresponding to the specified SQLSTATE or *condition-name*.

Processing a RESIGNAL statement: If the RESIGNAL statement is specified without an SQLSTATE clause or a *condition-name*, the SQL routine resignals the identical condition that invoked the handler and the SQLCODE is not changed.

When a RESIGNAL statement is issued and an SQLSTATE or *condition-name* is specified, the SQLCODE is based on the SQLSTATE value as follows:

- If the specified SQLSTATE class is either '01' or '02', a warning or not found is signaled and the SQLCODE is set to +438.
- Otherwise, an exception is returned and the SQLCODE is set to -438.

Examples

The following example detects a division by zero error. The IF statement uses a SIGNAL statement to invoke the overflow condition handler. The condition handler uses a RESIGNAL statement to return a different SQLSTATE to the client application.

```
CREATE PROCEDURE divide (IN numerator INTEGER,
                        IN denominator INTEGER,
                        OUT divide_result INTEGER)
LANGUAGE SQL
CONTAINS SQL
BEGIN
  DECLARE overflow CONDITION FOR SQLSTATE '22003';
  DECLARE CONTINUE HANDLER FOR overflow
    RESIGNAL SQLSTATE '22375';
  IF denominator = 0 THEN
    SIGNAL overflow;
  ELSE
    SET divide_result = numerator / denominator;
  END IF;
END
```

RETURN statement

The RETURN statement is used to return from the routine.

- For an SQL scalar function, the scalar result of the function is returned. The body of an SQL scalar function must contain at least one RETURN statement and a RETURN statement must be executed when the function is invoked.
- For an SQL table function, the result table of the function is returned. A RETURN statement must be specified in the body of an SQL table function.
- For an SQL procedure, the RETURNS statement optionally returns an integer status value.

Syntax

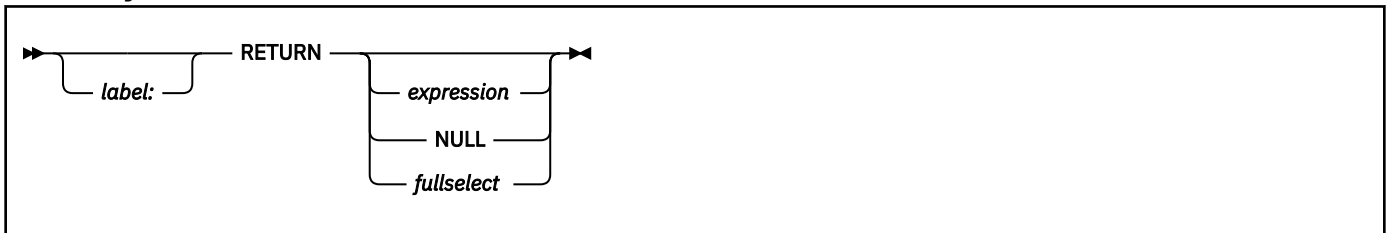

Description

label

Specifies the label for the RETURN statement. A label name cannot be the same as the routine name or another label within the same scope. For additional information, see [“References to SQL labels”](#) on page 2210.

expression

Specifies a value that is returned from the routine.

- If the routine is a scalar function, the data type of the result must be assignable to the data type that is defined for the function result, using the storage assignment rules as described in [“Assignment and comparison”](#) on page 143. The RETURN statement must not contain a period specification.

The body of any SQL function must not contain a reference to an aggregate function, or a reference to a user-defined function that is sourced on an aggregate function, or an OLAP specification.

In the body of an inlined SQL function, the RETURN statement must not contain a scalar fullselect. If the expression does not conform to this rule, Db2 attempts to define a compiled function.

To determine what type of SQL scalar function is created, refer to the INLINE column of the SYSIBM.SYSROUTINES catalog table. For more information about creating the two types of SQL

scalar functions, see [“CREATE FUNCTION statement \(inlined SQL scalar function\)”](#) on page 1489 and [“CREATE FUNCTION statement \(compiled SQL scalar function\)”](#) on page 1428.

- If the routine is a table function, a scalar expression (other than a scalar fullselect) cannot be specified. The data type of the result column of the fullselect must be assignable to the data type that is defined for the function result, using the storage assignment rules as described in [“Assignment and comparison”](#) on page 143. The outer fullselect in the RETURN statement of an SQL table function must not contain an *offset-clause* or *fetch-clause*, and the RETURN statement must not contain a period specification.
- If the routine is a procedure, the data type of *expression* must be INTEGER.

NULL

The null value is returned from the SQL routine.

- If the routine is a scalar function, the null value is returned.
- If the routine is a table function, NULL must not be specified.
- If the routine is a procedure, NULL must not be specified.

fullselect

Specifies the row or rows that are returned from the routine.

- If the routine is a scalar function, the function is a compiled function and the fullselect must return one column and, at most, one row. The data type of the result column must be assignable to the data type that is defined for the function result, using the storage assignment rules as described in [“Assignment and comparison”](#) on page 143.
- If the routine is a table function, the fullselect can return zero or more rows with one or more columns. The number of columns in the fullselect must match the number of columns in the function result. In addition, the data types of the result table columns of the fullselect must be assignable to the data types of the columns that are defined for the function result, using the storage assignment rules as described in [“Assignment and comparison”](#) on page 143.
- If the routine is a procedure, fullselect must not be specified.

Notes

Considerations for SQL functions: A RETURN statement in an SQL function must specify *expression*, NULL, or *fullselect*. For an inlined SQL scalar function, only a single *expression* can be specified in the RETURN statement, and the *expression* must not include a scalar fullselect. Only a single RETURN statement can be specified in the routine body of an SQL table function. The execution of an SQL function must end with a RETURN statement.

A data change table reference is not allowed in a RETURN statement in an SQL function.

Considerations for SQL procedures:

- **When a RETURN statement is used within an SQL procedure:** If a RETURN statement with a specified return value was used to return from a procedure, the SQLCODE, SQLSTATE, and message length in the SQLCA are initialized to zeros and the message text is set to blanks. An error is not returned to the caller.
- **When a RETURN statement is not used within an SQL procedure or when no value is specified:** If a RETURN statement was not used to return from a procedure or if a value is not specified on the RETURN statement, one of the following values is set:
 - If the procedure returns with an SQLCODE that is greater or equal to zero, the specified target for DB2_RETURN_STATUS in a GET DIAGNOSTICS statement will be set to a value of zero.
 - If the procedure returns with an SQLCODE that is less than zero, the specified target for DB2_RETURN_STATUS in a GET DIAGNOSTICS statement will be set to a value of '-1'.
- **When the value is returned from an SQL procedure:** When a value is returned from a procedure, the caller may access the value using one of the following methods:
 - The GET DIAGNOSTICS statement to retrieve the RETURN_STATUS when the SQL procedure was called from another SQL procedure.

- The parameter bound for the return value parameter marker in the escape clause CALL syntax (?=CALL...) in a CLI application.
- Directly from the SQLCA returned from processing the CALL of an SQL procedure by retrieving the value of sqlerrd[0]. When the SQLCODE is less than zero, the sqlerrd[0] value is not set. The application should assume a return status value of '-1'.

Restrictions:

- The RETURN statement must not be specified in a trigger.
- An SQL table function must contain a single RETURN statement.

Examples

Example 1: Use a RETURN statement to return from an SQL procedure with a status value of zero if successful or '-200' if not successful.

```
BEGIN
    . . .
    GOTO FAIL;
SUCCESS: RETURN 0;
FAIL: RETURN -200;
END
```

Example 2: Define a scalar function that returns the tangent of a value using the existing sine and cosine functions:

```
CREATE FUNCTION TAN (X DOUBLE)
RETURNS DOUBLE
LANGUAGE SQL CONTAINS SQL NO EXTERNAL ACTION
DETERMINISTIC
RETURN SIN(x)/COS(x)
```

SIGNAL statement

The SIGNAL statement is used to return an exception or warning condition. It causes an error or warning to be returned with the specified SQLSTATE, along with optional message text. The SIGNAL statement places the specified condition information in the cleared diagnostics area.

Syntax

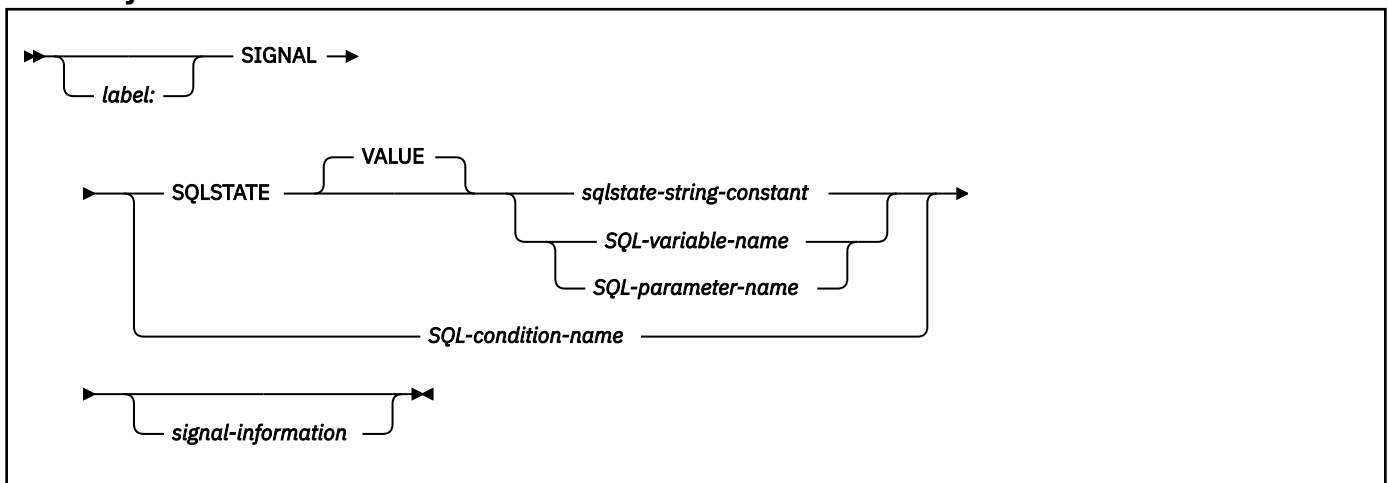

signal-information:

SET MESSAGE_TEXT = diagnostic-string-expression
(diagnostic-string-expression) 1

Notes:

¹ (diagnostic-string-expression) must only be specified within a trigger body.

Description

label

Specifies the label for the SIGNAL statement. A label name cannot be the same as the routine name, advanced trigger name, or another label within the same scope. For additional information, see [“References to SQL labels”](#) on page 2210.

SQLSTATE VALUE

Specifies the SQLSTATE that will be returned. Any valid SQLSTATE value can be used. It must be a character string constant with exactly five characters that follow the rules for SQLSTATES:

- Each character must be from the set of digits ('0' through '9') or non-accented upper case letter ('A' through 'Z').
- The SQLSTATE class (the first two characters) cannot be '00' because it represents successful completion.

In the context of a MERGE statement, the following rules also apply:

- The SQLSTATE class (first two characters) cannot be '01' or '02', because these are not error classes.
- If the SQLSTATE class starts with the numbers '0' through '6' or the letters 'A' through 'H', the subclass (the last three characters) must start with a letter in the range of 'I' through 'Z'.
- If the SQLSTATE class starts with the numbers '7', '8', '9', or the letters 'I' through 'Z', the subclass can be any of '0' through '9' or 'A' through 'Z'.

If the SQLSTATE does not conform to these rules, an error occurs.

sqlstate-string-constant

A character string constant with an actual length of five bytes that is a valid SQLSTATE value.

SQL-variable-name or *SQL-parameter-name*

Specifies an SQL variable or SQL parameter that contains a valid SQLSTATE value.

SQL-variable-name

Specifies an SQL variable that is declared within the *compound-statement* that contains the SIGNAL statement, or within a compound statement in which that compound statement is nested. *SQL-variable-name* must be defined as a CHAR or VARCHAR data type with an actual length of five bytes, must not be null, and must contain a valid SQLSTATE value.

SQL-parameter-name

Specifies an SQL parameter that is defined for the routine and contains the SQLSTATE value. The SQL parameter must be defined as a CHAR or VARCHAR data type with an actual length of five bytes, must not be null, and must contain a valid SQLSTATE value.

SQL-condition-name

Specifies the name of the condition that will be returned. The *SQL-condition-name* must be declared within the compound statement that contains the SIGNAL statement, or within a compound statement in which that compound statement is nested.

SET MESSAGE_TEXT

Specifies a string that describes the error or warning. The string is returned in the SQLERRMC field of the SQLCA or with the GET DIAGNOSTICS statement.

diagnostic-string-expression

An expression with a data type of CHAR or VARCHAR that returns a character string of up to 1000 bytes that describes the error or warning condition. For information on how to obtain the complete message text, see [“GET DIAGNOSTICS statement” on page 1949](#).

(*diagnostic-string-expression*)

An expression with a data type of CHAR or VARCHAR that returns a character string of up to 1000 bytes that describes the error or warning condition. For information on how to obtain the complete message text, see [“GET DIAGNOSTICS statement” on page 1949](#).

This syntax variation is only provided within the scope of a CREATE TRIGGER statement for compatibility with previous versions of Db2. To conform with the ANS and ISO standards, this form should not be used.

Notes

While any valid SQLSTATE value can be used in the SIGNAL statement, programmers should define new SQLSTATES based on ranges reserved for applications. This practice prevents the unintentional use of an SQLSTATE value that might be defined by the database manager in a future release.

If the SQLSTATE or condition indicates that an exception is signaled:

- If a condition handler exists in the same compound statement as the SIGNAL statement, and the compound statement contains a condition handler for SQLEXCEPTION or the specified SQLSTATE or condition, the exception is handled and control is transferred to that condition handler.
- If the compound statement is nested and the outer level compound statement has a condition handler for SQLEXCEPTION or the specified SQLSTATE or condition, the exception is handled and control is transferred to that condition handler.
- Otherwise, the exception is not handled and control is immediately returned to the end of the compound statement.

If the SQLSTATE or condition indicates that a warning or not found condition is signaled:

- If a condition handler exists in the same compound statement as the SIGNAL statement, and the compound statement contains a condition handler for SQLWARNING, NOT FOUND, or the specified SQLSTATE or condition, the warning or not found condition is handled and control is transferred to that condition handler.
- If the compound statement is nested and an outer level compound statement contains a condition handler for SQLWARNING, NOT FOUND, or the specified SQLSTATE or condition, the warning or not found condition is handled and control is transferred to that condition handler.
- Otherwise, the warning or not found condition is not handled and processing continues with the next statement.

Considerations for the diagnostics area: The SIGNAL statement starts with a clear diagnostics area and sets the RETURNED_SQLSTATE to reflect the specified SQLSTATE or *condition-name*. If message text is specified, the MESSAGE_TEXT item of the condition area is assigned the specified value. DB2_RETURNED_SQLCODE is set to +438 or -438 corresponding to the specified SQLSTATE or *condition-name*.

Examples

- The following example shows an SQL procedure for an order system that signals an application error when a customer number is not known to the application. The ORDERS table includes a foreign key to the CUSTOMER table, requiring that the CUSTNO exist before an order can be inserted.

```
CREATE PROCEDURE SUBMIT_ORDER
    (IN ONUM INTEGER, IN CNUM INTEGER,
     IN PNUM INTEGER, IN QNUM INTEGER)
LANGUAGE SQL
SPECIFIC SUBMIT_ORDER
MODIFIES SQL DATA
BEGIN
```



```

DECLARE EXIT HANDLER FOR SQLSTATE VALUE '23503'
  SIGNAL SQLSTATE '75002'
    SET MESSAGE_TEXT = 'Customer number is not known';
INSERT INTO ORDERS (ORDERNO, CUSTNO, PARTNO, QUANTITY)
  VALUES (ONUM, CNUM, PNUM, QNUM);
END

```

- The following example shows a trigger for an order system that allows orders to be recorded in an ORDERS table (ORDERNO, CUSTNO, PARTNO, QUANTITY) only if there is sufficient stock in the PARTS tables. When there is insufficient stock for an order, SQLSTATE '75001' is returned along with an appropriate error description.

```

CREATE TRIGGER CK_AVAIL
NO CASCADE BEFORE INSERT ON ORDERS
REFERENCING NEW AS NEW_ORDER
FOR EACH ROW MODE DB2SQL
WHEN (NEW_ORDER.QUANTITY > (SELECT ON_HAND FROM PARTS
  WHERE NEW_ORDER.PARTNO = PARTS.PARTNO))
  BEGIN ATOMIC
    SIGNAL SQLSTATE '75001' ('Insufficient stock for order');
  END

```

WHILE statement

The WHILE statement repeats the execution of a statement or group of statements while a specified condition is true.

Syntax

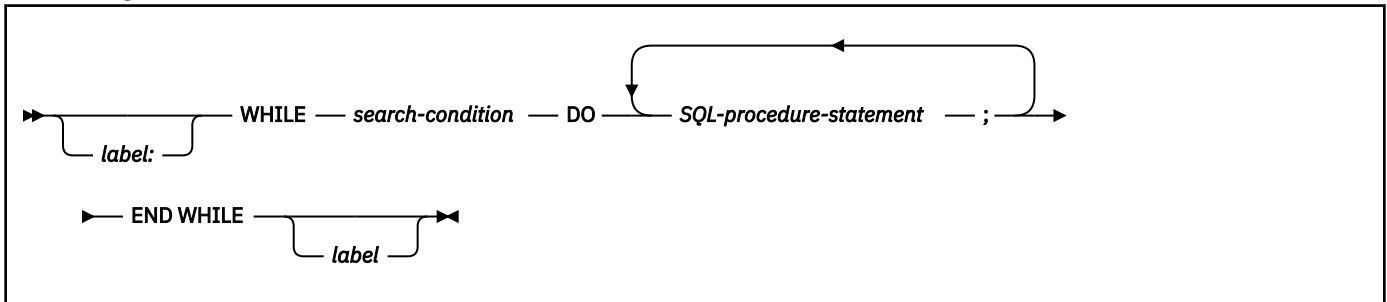

Description

label

Specifies the label for the WHILE statement. If the ending label is specified, it must be the same as the beginning label. A label name cannot be the same as the routine name, advanced trigger name, or another label within the same scope. For additional information, see [“References to SQL labels”](#) on page 2210.

search-condition

Specifies a condition that is evaluated before each execution of the loop. If the condition is true, the SQL procedure statements in the loop are executed.

SQL-procedure-statement

Specifies a statement to be run within the WHILE loop. The statement must be one of the statements listed under [“SQL-procedure-statement \(SQL PL\)”](#) on page 2212.

Notes

Considerations for the diagnostics area: At the beginning of the first iteration of the WHILE statement, and with every subsequent iteration, the diagnostics area is cleared.

Considerations for the SQLSTATE and SQLCODE SQL variables: With each iteration of the WHILE statement, when the first SQL-procedure-statement is executed, the SQLSTATE and SQLCODE SQL variables reflect the result of evaluating the search condition of that WHILE statement. If the loop is

terminated with a GOTO, ITERATE, or LEAVE statement, the SQLSTATE and SQLCODE values reflect the successful completion of that statement. Otherwise, after the END WHILE of the WHILE statement completes, the SQLSTATE and SQLCODE reflect the result of evaluating that search condition of that WHILE statement.

Examples

Use a WHILE statement to fetch rows from a table while SQL variable *at_end*, which indicates whether the end of the table has been reached, is 0.

```
WHILE at_end = 0 DO
  FETCH c1 INTO
    v_firstname, v_midinit,
    v_lastname, v_edlevel, v_salary;
  IF SQLCODE=100 THEN SET at_end=1;
END IF;
END WHILE;
```

Appendix A. Limits in Db2 for z/OS

Db2 for z/OS has system limits, object and SQL limits, length limits for identifiers and strings, and limits for certain data type values.

System storage limits might preclude the limits specified in this section. The limit for items not that are not specified below is limited by system storage.

The following table shows the length limits for identifiers.

Table 242. Identifier length limits. The term *byte(s)* in this table means the number of bytes for the UTF-8 representation unless noted otherwise.

Item	Limit
External-java-routine-name	1305 bytes
Name of an alias “1” on page 2248 , auxiliary table, collection, clone table, constraint, correlation, cursor (except for DECLARE CURSOR WITH RETURN or the EXEC SQL utility), distinct type (both parts of two-part name), function (both parts of two-part name), host identifier, index, JARs, parameter, procedure, role, schema, sequence, specific, statement, storage group, savepoint, SQL condition, SQL label, SQL parameter, SQL variable, synonym, table, trigger, view, XML attribute name, XML element name	128 bytes
Name of an authorization ID or name of a security label.	8 bytes
Routine version identifier	64 EBCDIC bytes, and the UTF-8 representation of the name must not exceed 122 bytes.
Name of a column	30 bytes “1” on page 2248
Name of cursor that is created with DECLARE CURSOR WITH RETURN	30 bytes
Name of cursor that is created with the EXEC SQL utility	8 bytes
Name of a location	16 bytes
Name of a database, table space, or buffer pool	8 bytes
Name of a plan or program	8 bytes
Name of a package	8 bytes (Only 8 EBCDIC characters are used for packages that are created with the BIND PACKAGE command. 128 bytes can be used for packages that are created as a result of the CREATE FUNCTION (SQL scalar) statement, the CREATE PROCEDURE (SQL - native) statement, the CREATE TRIGGER statement, or a BIND command that specifies a zFS file as DBRM library.)
Name of a profile that is created with CREATE TRUSTED CONTEXT or ALTER TRUSTED CONTEXT	127 bytes
Name of an ICF catalog.	8 bytes

Table 243. Numeric limits (continued)

Item	Limit
Maximum Exponent (E_{\max}) for DECFLOAT values	DECFLOAT(16) is 384; DECFLOAT(34) is 6144
Minimum Exponent (E_{\min}) for DECFLOAT values	DECFLOAT(16) is -383; DECFLOAT(34) is -6143
Bias for DECFLOAT values	DECFLOAT(16) is 398; DECFLOAT(34) is 6176

Note:

1. These are the limits for normal numbers in DECFLOAT. DECFLOAT also contains special values such as NaN and Infinity that are also valid. DECFLOAT also supports subnormal numbers that are outside of the documented range.

The following table shows the length limits for strings.

Table 244. String length limits

Item	Limit
Maximum length of CHAR	255 bytes
Maximum length of GRAPHIC	127 double-byte characters
Maximum length of BINARY	255 bytes
Maximum length ^{"1"} on page 2250 of VARCHAR	<ul style="list-style-type: none"> • 4046 bytes for a column in a table in a table space with 4 KB pages • 8128 bytes for a column in a table in a table space with 8 KB pages • 16320 bytes for a column in a table in a table space with 16 KB pages • 32704 bytes for a column in a table in a table space with 32 KB pages Otherwise, 32704 bytes
Maximum length of VARCHAR that can be indexed by an XML index	1000 bytes after conversion to UTF-8
Maximum length ^{"1"} on page 2250 of VARGRAPHIC	<ul style="list-style-type: none"> • 2023 double-byte characters for a column in a table in a table space with 4 KB pages • 4064 double-byte characters for a column in a table in a table space with 8 KB pages • 8160 double-byte characters for a column in a table in a table space with 16 KB pages • 16352 double-byte characters for a column in a table in a table space with 32 KB pages Otherwise, 16352 double-byte characters

Table 244. String length limits (continued)

Item	Limit
Maximum length ¹ of VARBINARY	<ul style="list-style-type: none"> • 4046 bytes for a column in a table in a table space with 4 KB pages • 8128 bytes for a column in a table in a table space with 8 KB pages • 16320 bytes for a column in a table in a table space with 16 KB pages • 32704 bytes for a column in a table in a table space with 32 KB pages Otherwise, 32704 bytes
Maximum length of CLOB	2147483647 bytes (2 GB - 1 byte)
Maximum length of DBCLOB	1073741823 double-byte characters
Maximum length of BLOB	2147483647 bytes (2 GB - 1 byte)
Maximum length of a character constant	32704 UTF-8 bytes
Maximum length of a hexadecimal character constant	32704 hexadecimal digits
Maximum length of a graphic string constant	16352 double-byte characters (32704 bytes when expressed in UTF-8)
Maximum length of a hexadecimal graphic string constant	32704 hexadecimal digits
Maximum length of a text string used for a scalar expression	4000 UTF-8 bytes
Maximum length of a concatenated character string	2147483647 bytes (2 GB - 1 byte)
Maximum length of a concatenated graphic string	1073741824 double-byte characters
Maximum length of a concatenated binary string	2147483647 bytes (2 GB - 1 byte)
Maximum length of XML pattern text	4000 bytes after conversion to UTF-8
Maximum length of an XML element or attribute name in an XML document	1000 bytes
Maximum length of a namespace uri	1000 bytes
Maximum length of a namespace prefix	998 bytes
Largest depth of an internal XML tree	128 levels

Note:

1. The maximum length can be achieved only if the column is the only column in the table. Otherwise, the maximum length depends on the amount of space remaining on a page.

The following table shows the minimum and maximum limits for datetime values.

Table 245. Datetime limits

Item	Limit
Smallest DATE value (shown in ISO format)	0001-01-01
Largest DATE value (shown in ISO format)	9999-12-31

Table 245. Datetime limits (continued)

Item	Limit
Smallest TIME value (shown in ISO format)	00.00.00
Largest TIME value (shown in ISO format)	24.00.00
Smallest TIMESTAMP WITHOUT TIME ZONE value	0001-01-01-00.00.00.000000000000
Largest TIMESTAMP WITHOUT TIME ZONE value	9999-12-31-24.00.00.000000000000 “1” on page 2251
Smallest TIMESTAMP WITH TIME ZONE value	0001-01-01-00.00.00.000000000000 +00:00
Largest TIMESTAMP WITH TIME ZONE value	9999-12-31-24.00.00.000000000000 +00:00 “1” on page 2251
TIMESTAMP precision range	0 to 12
TIME ZONE hour range	-24 to 24
TIME ZONE minute range	0 to 59

Note:

1. The maximum value is stated as a UTC value. When a timestamp without a time zone is compared to a timestamp with time zone, a necessary adjustment is made using the implicit time zone. During that adjustment, the timestamp without time zone could be converted to a value that is greater than the maximum value for a timestamp with time zone value (this could occur on operations such as comparison and assignment). This situation can be avoided by using '9999-12-30-00.00.00.000000000000' as the maximum value for timestamp without time zone and '9999-12-30-00.00.00.000000000000 +00:00' as the maximum value for timestamp with time zone columns.

The following table shows the Db2 limits on SQL statements.

Table 246. Db2 limits on SQL statements

Item	Limit
Maximum number of columns that are in a table or view (the value depends on the complexity of the CREATE VIEW statement) or columns returned by a table function.	750 or fewer (including hidden columns) 749 if the table is a dependent
Maximum number of columns that can be referenced in the target of MERGE statement.	749
Maximum number of expressions that can be referenced in the source of a MERGE statement.	750
Approximate maximum number of base tables in a SELECT, UPDATE, INSERT, MERGE, or DELETE statement or view	1024
Maximum number of tables in a FROM clause	225 or fewer, depending on the complexity of the statement
Maximum number of rows inserted with a single MERGE statement or FOR <i>n</i> ROWS form of INSERT statement	32767
Maximum row and record sizes for a table	See the maximum record size table under CREATE TABLE.
Maximum number of volume IDs in a storage group	133

Table 246. Db2 limits on SQL statements (continued)

Item	Limit
Maximum number of partitions in a partitioned table space or partitioned index	<p>4096 for most table space types, depending on the DSSIZE value and buffer pool page size.</p> <p>64 for table spaces not defined with a DSSIZE greater than 2GB (or the LARGE clause "1" on page 2254).</p>
Maximum sum of the lengths of limit key values of a partition boundary	765 UTF-8 bytes
Maximum size of a partition (table space or index)	<p>For partition-by-range table spaces with relative numbering:</p> <p>1 TB</p> <p>For table spaces that are defined with a DSSIZE greater than 4 GB:</p> <p>256 GB, depending on the page size (for 1 to 64 partitions for 4 KB pages, for 1 to 128 partitions for 8 KB pages, for 1–256 partitions for 16 KB pages, and 1–512 partitions for 32 KB pages)</p> <p>For table spaces that are defined with a DSSIZE of 4 GB (or the LARGE clause "1" on page 2254):</p> <p>4 GB, for 1–4096 partitions</p> <p>For table spaces with a DSSIZE not greater than 2 GB (and not defined with the LARGE clause "1" on page 2254):</p> <p>4 GB, for 1–16 partitions 2 GB, for 17–32 partitions 1 GB, for 33–64 partitions</p>
Maximum size of a non-partitioned index for a partitioned table space	<p>For 5-byte EA table spaces:</p> <p>16 TB for 4 KB pages 32 TB for 8 KB pages 64 TB for 16 KB pages 128 TB for 32 KB pages</p> <p>For table spaces that are defined with the LARGE clause "1" on page 2254:</p> <p>16 TB</p>
Maximum length of an index key	<ul style="list-style-type: none"> • Partitioning index: 255-<i>n</i> • Nonpartitioning index that is padded: 2000-<i>n</i> • Nonpartitioning index that is not padded: 2000 - <i>n</i> - 2<i>m</i> - 3<i>d</i> <p>n Number of columns in the key that allow nulls</p> <p>m Number of varying-length columns in the key</p> <p>d Number of DECFLOAT columns in the key</p>

Table 246. Db2 limits on SQL statements (continued)

Item	Limit
Maximum number of bytes used in the partitioning of a partitioned index	255 (This maximum limit is subject to additional limitations, depending on the number of partitions in the table space. The number of partitions * (106 + limit key size) must be less than 65394.)
Maximum number of columns in an index key	64
Maximum number of expressions in an index key	64
Maximum number of subqueries in a statement	224
Maximum total length of host and indicator variables pointed to in an SQLDA	32767 bytes 2147483647 bytes (2 GB - 1 byte) for a LOB, subject to the limitations that are imposed by the application environment and host language
Maximum size of application SQLDA for any statement that references host variables or parameter markers	99016 bytes
Maximum length of host variable used for insert or update operation	32704 bytes for a non-LOB 2147483647 bytes (2 GB - 1 byte) for a LOB, subject to the limitations that are imposed by the application environment and host language
Maximum number of host variables or parameter markers in a statement	16000 for a distributed application that originated from a client other than z/OS. Otherwise: <ul style="list-style-type: none"> • 2205 for an application without any LOB or distinct type host variables or parameter markers • 750 for an application with one or more LOB or distinct type host variables or parameter markers
Maximum length of an SQL statement	2097152 bytes
Maximum number of elements in a select list	750 or fewer, depending on whether the select list is for the result table of static scrollable cursor " 2 " on page 2254
Maximum number of elements in an IN list	32767
Maximum number of predicates in a WHERE or HAVING clause	Limited by storage
Maximum number of elements in a CUBE grouping	16
Maximum total length of columns of a query operation requiring sort and evaluating aggregate functions (MULTIPLE DISTINCT and GROUP BY)	65529 bytes
Maximum length of a sort key	32707 bytes
Maximum length of a check constraint	3800 bytes
Maximum number of bytes that can be passed in a single parameter of an SQL CALL statement	32765 bytes for a non-LOB 2147483647 bytes (2 GB - 1 byte) for a LOB, subject to the limitations imposed by the application environment and host language

Table 246. Db2 limits on SQL statements (continued)

Item	Limit
Maximum number of stored procedures, triggers, and user-defined functions that an SQL statement can implicitly or explicitly reference	64 nesting levels
Maximum number of parameters in a procedure or function	The SQL statement that contains the parameter list cannot exceed the maximum length of an SQL statement.
Maximum length of the SQL path	2048 bytes
Maximum length of a WLM environment name in a CREATE PROCEDURE, CREATE FUNCTION, ALTER PROCEDURE, or ALTER FUNCTION statement.	32 bytes
Maximum number of XPath level in the XMLPATTERN clause of the CREATE INDEX statement.	50 nesting levels

Note:

1. CREATE TABLESPACE statements support the LARGE clause for compatibility with earlier releases of Db2 for z/OS. However, the DSSIZE clause is the preferred method for specifying maximum partition size of 4 GB or larger. Do not specify LARGE if a DSSIZE clause is specified. For more information, see "Non-large table spaces (deprecated)" in [Table space types and characteristics in Db2 for z/OS \(Db2 Administration Guide\)](#).
2. If the scrollable cursor is read-only, the maximum number is 749 less the number of columns in the ORDER BY that are not in the select list. If the scrollable cursor is not read-only, the maximum number is 747.

The following table shows the Db2 system limits.

Table 247. Db2 system limits

Item	Limit
Maximum number of concurrent Db2 or application agents	Limited by the EDM pool size, buffer pool size, and the amount of storage that is used by each Db2 or application agent
Maximum number of concurrently active audit policies	32
Maximum size of a non-LOB table or table space	128 terabytes (TB)
Maximum size of a simple or segmented table space	64 GB
Maximum size of a physical log record	36,000 bytes
Maximum size of a log space	6-byte format: 2 ⁴⁸ bytes 10-byte format: 2 ⁸⁰ bytes
Maximum size of an active log data set	768 GB minus 1 byte
Maximum size of an archive log data set	768 GB minus 1 byte
Maximum number of active log copies	2
Maximum number of archive log copies	2
Maximum number of active log data sets (each copy)	93
Maximum number of archive log volumes (each copy)	10000
Maximum number of databases accessible to an application or user	Limited by system storage and EDM pool size

Table 247. Db2 system limits (continued)

Item	Limit
Maximum number of databases	65217
Maximum number of implicitly created databases	Maximum value of the sequence SYSIBM.DSNSEQ_IMPLICITDB, with a default of 10000
Maximum number of internal objects for each database ¹	32767
Maximum number of indexes on declared global temporary tables	10000
Maximum size of an EDM pool	The installation parameter maximum depends on available space
Maximum number of rows per page	255 for all table spaces except catalog and directory tables spaces, which have a maximum of 127
Maximum simple or segmented data set size	2 GB
Maximum partitioned data set size	See item "maximum size of a partition" in Table 246 on page 2251
Maximum LOB data set size	256 GB
Maximum number of data sets for a LOB table space	254
Maximum storage per thread for LOB data	2 GB
Maximum number of table spaces that can be defined in a work file database	500
Maximum number of tables and triggers that can be defined in a work file database	11767
Maximum number of active profiles in DSN_PROFILE_TABLE profile table	4096

Note:

1. The number of internal object descriptors (OBDs) for external objects are as follows:

- Table space: 2
- Table: 1
- Index: 2
- Check constraint: 1
- Referential integrity relationship: 2
- Auxiliary relationship for each LOB column: 1
- XML relationship for each XML column: 1
- Trigger: 1
- View that has an INSTEAD OF trigger: 1

Appendix B. Reserved schema names and reserved words in Db2 for z/OS

Restrictions exist on the use of certain words that are used by Db2 for z/OS. In some cases, these names are reserved and cannot be used by application programs. In other cases, certain names are not recommended for use by application programs though not prevented from being used by the database manager.

Reserved schema names in Db2 for z/OS

In general, for certain objects, schema names that begin with the prefix SYS are reserved. The schema name for these objects cannot begin with SYS except for certain exceptions.

The schema name for the objects listed in the following table must follow the restrictions listed in the table.

Recommendations:

- Do not to use SESSION as a schema name.
- Do not use SYSPUBLIC as a schema name for a table or view.

Object	Schema name restriction	Schema name exceptions
Distinct types	Cannot begin with SYS	The schema name can be: <ul style="list-style-type: none">• SYSADM• SYSTOOLS¹
User-defined functions	Cannot begin with SYS	The schema name can be: <ul style="list-style-type: none">• SYSADM• SYSTOOLS¹• SYSFUN²
Stored procedures	Cannot begin with SYS	The schema name can be: <ul style="list-style-type: none">• SYSADM• SYSFUN²• SYSIBM• SYSIBMADM• SYSPROC• SYSTOOLS¹
Sequences	Cannot begin with SYS	The schema name can be: <ul style="list-style-type: none">• SYSADM
Triggers	Cannot begin with SYS	The schema name can be: <ul style="list-style-type: none">• SYSADM• SYSTOOLS¹

Table 248. Objects with schema name restrictions and exceptions. (continued)

Object	Schema name restriction	Schema name exceptions
Column masks	Cannot begin with SYS	The schema name can be: <ul style="list-style-type: none"> • SYSADM
Row permissions	Cannot begin with SYS	The schema name can be: <ul style="list-style-type: none"> • SYSADM
<p>Notes:</p> <ol style="list-style-type: none"> 1. If the user who executes the CREATE statement has the SYSADM or SYSCTRL privilege. 2. For external user-defined scalar functions or external user-defined table functions if the user who executes the CREATE statement has the SYSADM or SYSCTRL privilege. 		

Related reference

[Reserved words in Db2 for z/OS](#)

Reserved words in Db2 for z/OS

Keywords can be used as ordinary identifiers, except in a context where they could also be interpreted as SQL syntax. When a keyword can be interpreted as SQL syntax the keyword is considered a *reserved word* in that context, which means that it cannot be used as an ordinary identifier. However, a keyword can be used as an identifier in a context where it is a reserved word, by specifying it as a delimited identifier. For example:

- ALL cannot be a column name in a SELECT statement, unless it is delimited. However, if the quotation mark (") is the escape character that begins and ends delimited identifiers, "ALL" can be used as a column name in a SELECT statement.
- COUNT cannot be used as a column name in a SELECT statement, unless it is also specified as delimited.

New reserved words for Db2 12 are identified by note ["1" on page 2267](#) in the following table. Some topics in this information might also indicate words that cannot be used in the specific context that is being described.

IBM SQL has additional reserved words that Db2 for z/OS does not enforce. Therefore, you should not use these additional reserved words as ordinary identifiers in names that have a continuing use. For a list of the reserved words, see [PDF SQL Reference for Cross-Platform Development - Version 6](#) for a list of the words.



Table 249. Reserved words in Db2 for z/OS

First letter	Reserved words
A	ADD AFTER ALL ALLOCATE ALLOW ALTER AND ANY AS ARRAY ARRAY_EXISTS ASENSITIVE ASSOCIATE ASUTIME AT AUDIT AUX AUXILIARY
B	BEFORE BEGIN BETWEEN BUFFERPOOL BY

Table 249. Reserved words in Db2 for z/OS (continued)

First letter	Reserved words
C	CALL CAPTURE CASCADED CASE CAST CCSID CHAR CHARACTER CHECK CLONE CLOSE CLUSTER COLLECTION COLLID COLUMN COMMENT COMMIT CONCAT CONDITION CONNECT CONNECTION CONSTRAINT CONTAINS CONTENT CONTINUE CREATE CUBE CURRENT CURRENT_DATE CURRENT_LC_CTYPE CURRENT_PATH CURRENT_SCHEMA FL 504 CURRENT_SERVER ^{“1”} on page 2267 CURRENT_TIME CURRENT_TIMESTAMP FL 504 CURRENT_TIMEZONE ^{“1”} on page 2267 CURRVAL CURSOR

Table 249. Reserved words in Db2 for z/OS (continued)

First letter	Reserved words
D	DATA DATABASE DAY DAYS DBINFO DECLARE DEFAULT DELETE DESCRIPTOR DETERMINISTIC DISABLE DISALLOW DISTINCT DO DOCUMENT DOUBLE DROP DSSIZE DYNAMIC
E	EDITPROC ELSE ELSEIF ENCODING ENCRYPTION END ENDING END-EXEC ^{“2” on page 2267} ERASE ESCAPE EXCEPT EXCEPTION EXECUTE EXISTS EXIT EXPLAIN EXTERNAL
F	FENCED FETCH FIELDPROC FINAL FIRST FOR FREE FROM FULL FUNCTION

Table 249. Reserved words in Db2 for z/OS (continued)

First letter	Reserved words
G	GENERATED GET GLOBAL GO GOTO GRANT GROUP
H	HANDLER HAVING HOLD HOUR HOURS
I	IF IMMEDIATE IN INCLUSIVE INDEX INHERIT INNER INOUT INSENSITIVE INSERT INTERSECT INTO IS ISOBID ITERATE
J	JAR JOIN
K	KEEP KEY

Table 249. Reserved words in Db2 for z/OS (continued)

First letter	Reserved words
L	LABEL LANGUAGE LAST LC_CTYPE LEAVE LEFT LIKE LIMIT ¹ on page 2267 LOCAL LOCALE LOCATOR LOCATORS LOCK LOCKMAX LOCKSIZE LONG LOOP
M	MAINTAINED MATERIALIZED MICROSECOND MICROSECONDS MINUTES MODIFIES MONTH MONTHS
N	NEXT NEXTVAL NO NONE NOT NULL NULLS NUMPARTS

Table 249. Reserved words in Db2 for z/OS (continued)

First letter	Reserved words
O	OBID OF OFFSET “1” on page 2267 OLD ON OPEN OPTIMIZATION OPTIMIZE OR ORDER ORGANIZATION OUT OUTER
P	PACKAGE PADDED PARAMETER PART PARTITION PARTITIONED PARTITIONING PATH PIECESIZE PERIOD PLAN PRECISION PREPARE PREVVAL PRIOR PRIQTY PRIVILEGES PROCEDURE PROGRAM PSID PUBLIC
Q	QUERY QUERYNO

Table 249. Reserved words in Db2 for z/OS (continued)

First letter	Reserved words
R	READS REFERENCES REFRESH RELEASE RENAME RESIGNAL REPEAT RESTRICT RESULT RESULT_SET_LOCATOR RETURN RETURNS REVOKE RIGHT ROLE ROLLBACK ROLLUP ROUND_CEILING ROUND_DOWN ROUND_FLOOR ROUND_HALF_DOWN ROUND_HALF_EVEN ROUND_HALF_UP ROUND_UP ROW ROWSET RUN

Table 249. Reserved words in Db2 for z/OS (continued)

First letter	Reserved words
S	SAVEPOINT SCHEMA SCRATCHPAD SECOND SECONDS SECQTY SECURITY SEQUENCE SELECT SENSITIVE SESSION_USER SET SIGNAL SIMPLE SOME SOURCE SPECIFIC STANDARD STATIC STATEMENT STAY STOGROUP STORES STYLE SUMMARY SYNONYM SYSDATE SYSTEM SYSTIMESTAMP
T	TABLE TABLESPACE THEN TO TRIGGER TRUNCATE TYPE
U	UNDO UNION UNIQUE UNTIL UPDATE USER USING

Table 249. Reserved words in Db2 for z/OS (continued)

First letter	Reserved words
V	VALIDPROC VALUE VALUES VARIABLE VARIANT VCAT VERSIONING VIEW VOLATILE VOLUMES
W	WHEN WHENEVER WHERE WHILE WITH WLM
X	XMLCAST XMLEXISTS XMLNAMESPACES
Y	YEAR YEARS
Z	ZONE

Notes:

1. New reserved word for Db2 12.
2. COBOL only



Related reference

[Reserved schema names in Db2 for z/OS](#)

In general, for certain objects, schema names that begin with the prefix SYS are reserved. The schema name for these objects cannot begin with SYS except for certain exceptions.

Appendix C. Actions allowed on SQL statements

Specific Db2 statements can be executed, prepared interactively or dynamically, or processed by the requester, the server, or the precompiler or coprocessor.

The following table shows whether a specific Db2 statement can be executed, prepared interactively or dynamically, or processed by the requester, the server, or the precompiler or coprocessor. The letter **Y** means yes.

Table 250. Actions allowed on SQL statements in Db2 for z/OS

SQL statement	Executable	Interactively or dynamically prepared	Processed by		
			Requesting system	Server	Precompiler or coprocessor
ALLOCATE CURSOR ¹	Y	Y	Y		
ALTER ²	Y	Y		Y	
ASSOCIATE LOCATORS ¹	Y	Y	Y		
BEGIN DECLARE SECTION					Y
CALL ¹	Y			Y	
CLOSE	Y			Y	
COMMENT	Y	Y		Y	
COMMIT ⁸	Y	Y		Y	
CONNECT	Y		Y		
CREATE ²	Y	Y		Y	
DECLARE CURSOR					Y
DECLARE GLOBAL TEMPORARY TABLE	Y	Y		Y	
DECLARE STATEMENT					Y
DECLARE TABLE					Y
DECLARE VARIABLE					Y
DELETE	Y	Y		Y	
DESCRIBE prepared statement or table	Y			Y	
DESCRIBE CURSOR	Y		Y		
DESCRIBE INPUT	Y			Y	
DESCRIBE PROCEDURE	Y		Y		
DROP ²	Y	Y		Y	
END DECLARE SECTION					Y
EXECUTE	Y			Y	
EXECUTE IMMEDIATE	Y			Y	

Table 250. Actions allowed on SQL statements in Db2 for z/OS (continued)

SQL statement	Executable	Interactively or dynamically prepared	Processed by		
			Requesting system	Server	Precompiler or coprocessor
EXPLAIN	Y	Y		Y	
FETCH	Y			Y	
FREE LOCATOR ¹	Y	Y		Y	
GET DIAGNOSTICS	Y			Y	
GRANT ²	Y	Y		Y	
HOLD LOCATOR ¹	Y	Y		Y	
INCLUDE					Y
INSERT	Y	Y		Y	
LABEL	Y	Y		Y	
LOCK TABLE	Y	Y		Y	
MERGE	Y	Y		Y	
OPEN	Y			Y	
PREPARE	Y			Y ⁴	
REFRESH TABLE	Y	Y		Y	
RELEASE connection	Y		Y		
RELEASE SAVEPOINT	Y	Y		Y	
RENAME ²	Y	Y		Y	
REVOKE ²	Y	Y		Y	
ROLLBACK ⁸	Y	Y		Y	
SAVEPOINT	Y	Y		Y	
SELECT INTO	Y			Y	
SET CONNECTION	Y		Y		
SET CURRENT APPLICATION ENCODING SCHEME	Y		Y		
SET CURRENT DEBUG MODE	Y	Y		Y	
SET CURRENT DECFLOAT ROUNDING MODE	Y	Y		Y	
SET CURRENT DEGREE	Y	Y		Y	
SET CURRENT GET_ACCEL_ARCHIVE	Y	Y		Y	
SET CURRENT LC_CTYPE	Y	Y		Y	
SET CURRENT MAINTAINED TABLE TYPES FOR OPTIMIZATION	Y	Y		Y	

Table 250. Actions allowed on SQL statements in Db2 for z/OS (continued)

SQL statement	Executable	Interactively or dynamically prepared	Processed by		
			Requesting system	Server	Precompiler or coprocessor
SET CURRENT OPTIMIZATION HINT	Y	Y		Y	
SET CURRENT PACKAGE PATH	Y		Y		
SET CURRENT PACKAGESET	Y			Y	
SET CURRENT PRECISION	Y	Y		Y	
SET CURRENT QUERY ACCELERATION	Y	Y		Y	
SET CURRENT REFRESH AGE	Y	Y		Y	
SET CURRENT ROUTINE VERSION	Y	Y		Y	
SET CURRENT RULES	Y	Y		Y	
SET CURRENT SQLID ⁵	Y	Y		Y	
SET <i>host-variable</i> = CURRENT APPLICATION ENCODING SCHEME	Y		Y		
SET <i>host-variable</i> = CURRENT DATE	Y			Y	
SET <i>host-variable</i> = CURRENT DEGREE	Y			Y	
SET <i>host-variable</i> = CURRENT MEMBER	Y			Y	
SET <i>host-variable</i> = CURRENT PACKAGESET	Y		Y		
SET <i>host-variable</i> = CURRENT PATH	Y			Y	
SET <i>host-variable</i> = CURRENT QUERY OPTIMIZATION LEVEL	Y			Y	
SET <i>host-variable</i> = CURRENT SERVER	Y		Y		
SET <i>host-variable</i> = CURRENT SQLID	Y			Y	
SET <i>host-variable</i> = CURRENT TIME	Y			Y	
SET <i>host-variable</i> = CURRENT TIMESTAMP	Y			Y	
SET <i>host-variable</i> = CURRENT TIMEZONE	Y			Y	
SET PATH	Y	Y		Y	

Table 250. Actions allowed on SQL statements in Db2 for z/OS (continued)

SQL statement	Executable	Interactively or dynamically prepared	Processed by		
			Requesting system	Server	Precompiler or coprocessor
SET SCHEMA	Y	Y		Y	
SET <i>transition-variable</i> = CURRENT DATE	Y			Y	
SET <i>transition-variable</i> = CURRENT DEGREE	Y			Y	
SET <i>transition-variable</i> = CURRENT PATH	Y			Y	
SET <i>transition-variable</i> = CURRENT QUERY OPTIMIZATION LEVEL	Y			Y	
SET <i>transition-variable</i> = CURRENT SQLID	Y			Y	
SET <i>transition-variable</i> = CURRENT TIME	Y			Y	
SET <i>transition-variable</i> = CURRENT TIMESTAMP	Y			Y	
SET <i>transition-variable</i> = CURRENT TIMEZONE	Y			Y	
SIGNAL ⁶	Y			Y	
TRUNCATE	Y	Y		Y	
UPDATE	Y	Y		Y	
VALUES ⁶	Y			Y	
VALUES INTO ⁷	Y			Y	
WHENEVER					Y

Table 250. Actions allowed on SQL statements in Db2 for z/OS (continued)

SQL statement	Executable	Interactively or dynamically prepared	Processed by		
			Requesting system	Server	Precompiler or coprocessor

Note:

1. The statement can be dynamically prepared. It cannot be issued dynamically.
2. The statement can be dynamically prepared only if DYNAMICRULES run behavior is implicitly or explicitly specified.
3. The statement can be dynamically prepared, but only from an ODBC or CLI driver that supports dynamic CALL statements.
4. The requesting system processes the PREPARE statement when the statement being prepared is ALLOCATE CURSOR or ASSOCIATE LOCATORS.
5. The value to which special register CURRENT SQLID is set is used as the SQL authorization ID for dynamic SQL statements only when DYNAMICRULES run behavior is in effect. The CURRENT SQLID value is ignored for the other DYNAMICRULES behaviors.
6. This statement can be used only in the triggered action of a trigger.
7. Local special registers can be referenced in a VALUES INTO statement if it results in the assignment of a single host-variable, not if it results in setting more than one value.
8. Some processing also occurs at the requester.

Related reference

Statements

This section contains syntax diagrams, semantic descriptions, rules, and examples of the use of the SQL statements.

SQL statement data access classification for routines

Certain SQL statements can be executed in a stored procedure or in a user-defined function. Whether the statements can be executed depends on the level of SQL data access with which the routine is defined.

Appendix D. SQL statement data access classification for routines

Certain SQL statements can be executed in a stored procedure or in a user-defined function. Whether the statements can be executed depends on the level of SQL data access with which the routine is defined.

The following table indicates whether an SQL statement (specified in the first column) is allowed to execute in a routine with the specified SQL data access classification. The letter **Y** means yes.

In general, if an executable SQL statement is encountered in a routine defined as NO SQL, SQLSTATE 38001 is returned. If the routine is defined to allow some level of SQL access, SQL statements that are not supported in any context return SQLSTATE 38003. SQL statements not allowed for routines defined as CONTAINS SQL return SQLSTATE 38004, and SQL statements not allowed for READS SQL DATA return SQLSTATE 38002.

Table 251. SQL data access classification for routines

SQL statement	Level of SQL data access			
	NO SQL	CONTAINS SQL	READS SQL DATA	MODIFIES SQL DATA
ALLOCATE CURSOR			Y	Y
ALTER				Y
ASSOCIATE LOCATORS			Y	Y
BEGIN DECLARE SECTION	Y ^{"1"} on page 2277	Y	Y	Y
CALL		Y ^{"2"} on page 2277	Y ^{"2"} on page 2277	Y ^{"2"} on page 2277
CLOSE			Y	Y
COMMENT				Y
COMMIT		Y	Y	Y
CONNECT		Y	Y	Y
CREATE				Y
DECLARE CURSOR	Y ^{"1"} on page 2277	Y	Y	Y
DECLARE GLOBAL TEMPORARY TABLE				Y
DECLARE STATEMENT	Y ^{"1"} on page 2277	Y	Y	Y
DECLARE TABLE	Y ^{"1"} on page 2277	Y	Y	Y
DECLARE VARIABLE	Y ^{"1"} on page 2277	Y	Y	Y
DELETE				Y
DESCRIBE			Y	Y
DESCRIBE CURSOR			Y	Y

Table 251. SQL data access classification for routines (continued)

SQL statement	Level of SQL data access			
	NO SQL	CONTAINS SQL	READS SQL DATA	MODIFIES SQL DATA
DESCRIBE INPUT			Y	Y
DESCRIBE OUTPUT			Y	Y
DESCRIBE PROCEDURE			Y	Y
DESCRIBE TABLE			Y	Y
DROP				Y
END DECLARE SECTION	Y ^{"1"} on page 2277	Y	Y	Y
EXCHANGE				Y
EXECUTE		Y ^{"3"} on page 2277	Y ^{"3"} on page 2277	Y
EXECUTE IMMEDIATE		Y ^{"3"} on page 2277	Y ^{"3"} on page 2277	Y
EXPLAIN				Y
FETCH			Y	Y
FREE LOCATOR		Y	Y	Y
GET DIAGNOSTICS		Y	Y	Y
GRANT				Y
HOLD LOCATOR		Y	Y	Y
INCLUDE	Y ^{"1"} on page 2277	Y	Y	Y
INSERT				Y
LABEL				Y
LOCK TABLE		Y	Y	Y
MERGE				Y
OPEN			Y	Y
PREPARE		Y	Y	Y
REFRESH TABLE				Y
RELEASE connection		Y	Y	Y
RELEASE SAVEPOINT				Y
RENAME				Y
REVOKE				Y
ROLLBACK		Y	Y	Y
ROLLBACK TO SAVEPOINT				Y
SAVEPOINT				Y
SELECT INTO			Y	Y

Table 251. SQL data access classification for routines (continued)

SQL statement	Level of SQL data access			
	NO SQL	CONTAINS SQL	READS SQL DATA	MODIFIES SQL DATA
SET CONNECTION		Y	Y	Y
SET assignment-statement		Y ^{"4"} on page 2277	Y	Y
SET special register		Y	Y	Y
SIGNAL		Y	Y	Y
TRUNCATE				Y
UPDATE				Y
VALUES			Y	Y
VALUES INTO		Y ^{"4"} on page 2277	Y	Y
WHENEVER	Y ^{"1"} on page 2277	Y	Y	Y

Notes:

1. Although the SQL option implies that no SQL statements can be specified, non-executable statements are not restricted.
2. The stored procedure that is called must have the same or more restrictive level of SQL data access than the current level in effect. For example, a routine defined as MODIFIES SQL DATA can call a stored procedure defined as MODIFIES SQL DATA, READS SQL DATA, CONTAINS SQL, or NO SQL. A routine defined as CONTAINS SQL can call a procedure defined as CONTAINS SQL or NO SQL.
3. The statement specified for the EXECUTE statement must be a statement that is allowed for the particular level of SQL data access in effect. For example, if the level in effect is READS SQL DATA, the statement must not be an INSERT, UPDATE, MERGE, or DELETE statement.
4. The statement is supported only if it does not contain a subquery or query-expression.

Related reference

Statements

This section contains syntax diagrams, semantic descriptions, rules, and examples of the use of the SQL statements.

Actions allowed on SQL statements

Specific Db2 statements can be executed, prepared interactively or dynamically, or processed by the requester, the server, or the precompiler or coprocessor.

Appendix E. SQL control statements for external SQL procedures

SQL control statements for external SQL procedures can be used only with SQL procedures that are created with the FENCED or EXTERNAL clause. *SQL control statements* provide the capability to control the logic flow, declare and set variables, and handle warnings and exceptions. Some SQL control statements include other nested SQL statements.

Deprecated function: External SQL procedures are deprecated and not as fully supported as native SQL procedures. For best results, create native SQL procedures instead. For more information, see [Creating native SQL procedures \(Db2 Application programming and SQL\)](#) and [Migrating an external SQL procedure to a native SQL procedure \(Db2 Application programming and SQL\)](#).

SQL-control-statement:

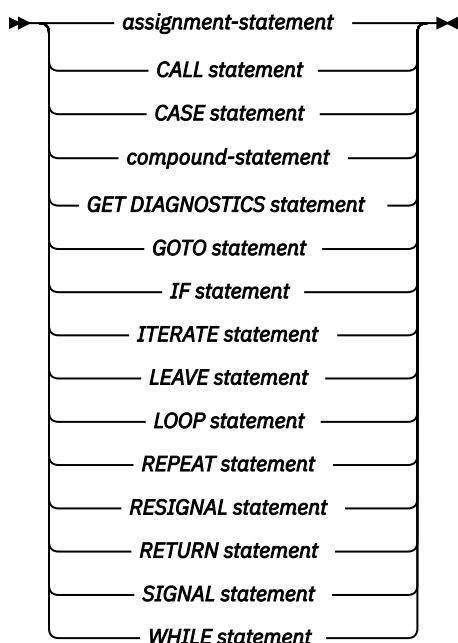

Control statements are supported in SQL procedures. External SQL procedures are created by specifying either FENCED or EXTERNAL, LANGUAGE SQL, and an SQL routine body on the “CREATE PROCEDURE statement (SQL - external procedure) (deprecated)” on page 1597 statement. The SQL routine body must be a single SQL statement which may be an SQL control statement.

The remainder of this section contains a description of the control statements that are supported for external SQL procedures, and includes syntax diagrams, semantic descriptions, usage notes, and examples of the use of the statements that constitute the SQL routine body. In addition, you can find information about referencing SQL parameters and variables in [“References to SQL parameters and SQL variables in external SQL procedures”](#) on page 2280.

The two common elements that are used in describing specific SQL control statements are:

- SQL control statements as described above
- [“SQL-procedure-statement \(external\)”](#) on page 2280

References to SQL parameters and SQL variables in external SQL procedures

SQL parameters, SQL variables, and transition variables can be referenced anywhere in the statement where an expression or a host variable can be specified. SQL parameters and SQL variables can be referenced anywhere in the compound statement in which they are declared and can be qualified with the label name that is specified at the beginning of the compound statement. Host variables cannot be specified in SQL routines. Use SQL variables, SQL parameters, and global variables instead of host variables in SQL routines. Use SQL variables, transition variables, and global variables in triggers.

All SQL parameters and SQL variables are considered nullable. The name of an SQL parameter or SQL variable in an SQL routine can be the same as the name of a column in a table or view that the SQL routine references. Names that are the same should be explicitly qualified. Qualifying a name clearly indicates whether the name refers to a column, SQL variable, or SQL parameter.

If the name is not qualified, the following rules describe whether the name refers to the column, the SQL variable, or the SQL parameter:

- The name is checked first as an SQL variable name and then as an SQL parameter name.
- If an SQL variable or SQL parameter by that name is not found, the name is assumed to be a column name.

The name of an SQL variable or SQL parameter in an SQL routine can be the name of an identifier that is used in certain SQL statements. If the name is not qualified, the following rules describe whether the name refers to the identifier, the SQL variable, or the SQL parameter:

- In the SET PATH and SET SCHEMA statements, the name is checked as an SQL variable name or an SQL parameter name. If an SQL variable or SQL parameter by that name is not found, the name is assumed to be an identifier.
- In the ASSOCIATE LOCATORS, CONNECT statement, the SET CONNECTION statement, and the RELEASE (connection) statement the name is used as an identifier.

Related concepts

Variables

A *variable* in an SQL statement specifies a value that can be changed when the SQL statement is executed. There are several types of variables used in SQL statements.

SQL-procedure-statement (external)

An SQL control statement may allow multiple SQL statements to be specified within the SQL control statement. These statements are defined as SQL procedure statements.

Syntax



Description

SQL-label

Specifies a label for the statement. *SQL-label* must not be a delimited identifier that includes lowercase letters or special characters. The label must be unique within the procedure.

SQL-control-statement

Specifies an SQL statement that provides the capability to control logic flow, declare and set variables, and handle warnings and exceptions, as defined in this section. Control statements are supported in SQL procedures.

SQL-statement

Specifies an SQL statement. These statements are described in [Chapter 7, “Statements,”](#) on page 1079.

Notes

Comments: Comments can be included within the body of an SQL procedure. In addition to the double-dash form of comments (--), a comment can begin with /* and end with */. The following rules apply to this form of comment:

- The beginning characters /* must be adjacent and on the same line.
- The ending characters */ must be adjacent and on the same line.
- Comments can be started wherever a space is valid.
- Comments can be continued to the next line.

Handling errors and warnings: Conditions can be detected within an SQL procedure by using the following methods:

- Test the special SQL variables SQLSTATE and SQLCODE.
- Issue a GET DIAGNOSTICS statement to request the condition information. See [“GET DIAGNOSTICS statement”](#) on page 1949.
- Define condition handlers to detect and process conditions. See [“compound-statement”](#) on page 2286 for information about defining condition handlers.

assignment-statement (SQL control statements for external routines)

The assignment statement assigns a value to an SQL parameter or to an SQL variable.

Syntax

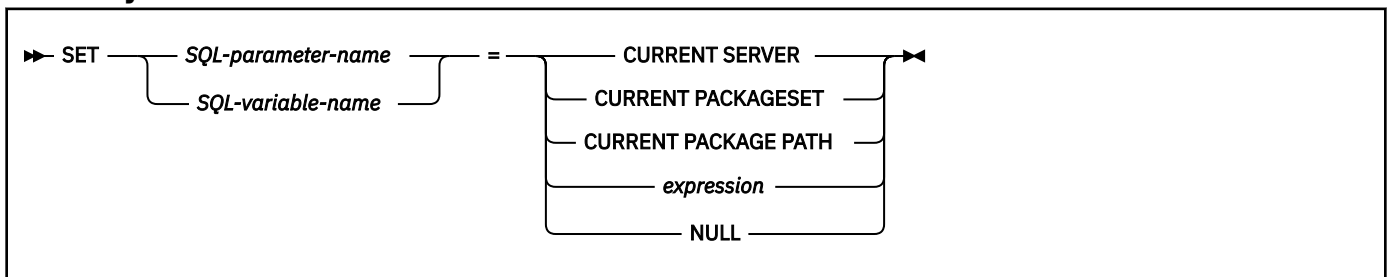

Description

SQL-parameter-name

Identifies the parameter that is the assignment target. The parameter must be specified in *parameter-declaration* in the CREATE PROCEDURE statement and must be defined as OUT or INOUT.

SQL-variable-name

Identifies the SQL variable that is the assignment target. SQL variables can be declared in a compound-statement and must be declared before it is used. For information on declaring SQL variables, see [“compound-statement”](#) on page 2286.

expression or NULL

Specifies the expression or value that is the assignment source. The expression can be any expression of the type described in [“Expressions”](#) on page 245 except it cannot contain a reference to local special registers (CURRENT SERVER, CURRENT PACKAGESET, or CURRENT PACKAGE PATH).

Notes

Assignment rules: Assignment statements in SQL procedures must conform to the SQL assignment rules. For example, the data type of the target and source must be compatible. See [“Assignment and comparison”](#) on page 143 for assignment rules.

When a string is assigned to a fixed-length variable and the length of the string is less than the length attribute of the target, the string is padded on the right with the necessary number of single-byte or double-byte blanks. When a string is assigned to a variable and the string is longer than the length attribute of the variable, the value is truncated and a warning is returned.

The ENCODING bind option is not used during processing of assignments to string variables. For example, assume that the system does not use mixed or DBCS, and the system EBCDIC SBCS CCSID is 37. Character conversion will not occur on assignment even if CCSID 500 is specified for the ENCODING bind parameter for the package for the procedure.

If truncation of the whole part of a number occurs on assignment to a numeric variable, the value is truncated and a warning is returned.

Assignments involving SQL parameters:

- An IN parameter can appear on the left side of an assignment statement. When control returns to the caller, the original value of an IN parameter is passed to the caller.
- An OUT parameter can appear on the left or right side of an assignment statement. When control returns to the caller, the last value that is assigned to an OUT parameter is returned to the caller.
- An INOUT parameter can appear on the left or right side of an assignment statement. The first value of the parameter is determined by the caller, and the last value that is assigned to the parameter is returned to the caller.
- A LOB parameter can not be used as an output value in an SQL statement in an SQL procedure when connected to a remote site. To circumvent the restriction, use a LOB SQL variable instead of a LOB parameter.

Considerations for SQLSTATE and SQLCODE SQL variables: Assignment to these variables is not prohibited. However, it is not recommended as assignment does not affect the diagnostic area or result in the activation of condition handlers. Furthermore, processing an assignment to these SQL variables causes the specified values for the assignment to be overlaid with the SQL return codes returned from executing the statement that does the assignment.

Examples

Increase the SQL variable *p_salary* by 10 percent.

```
SET p_salary = p_salary + (p_salary * .10)
```

Set SQL variable *p_salary* to the null value.

```
SET p_salary = NULL
```

Set SQL variable *midinit* to the first character of SQL variable *midname*.

```
SET midinit = SUBSTR(midname,1,1)
```

CALL statement

The CALL statement invokes a stored procedure.

Syntax

```
► CALL — procedure-name — argument-list ◄
```

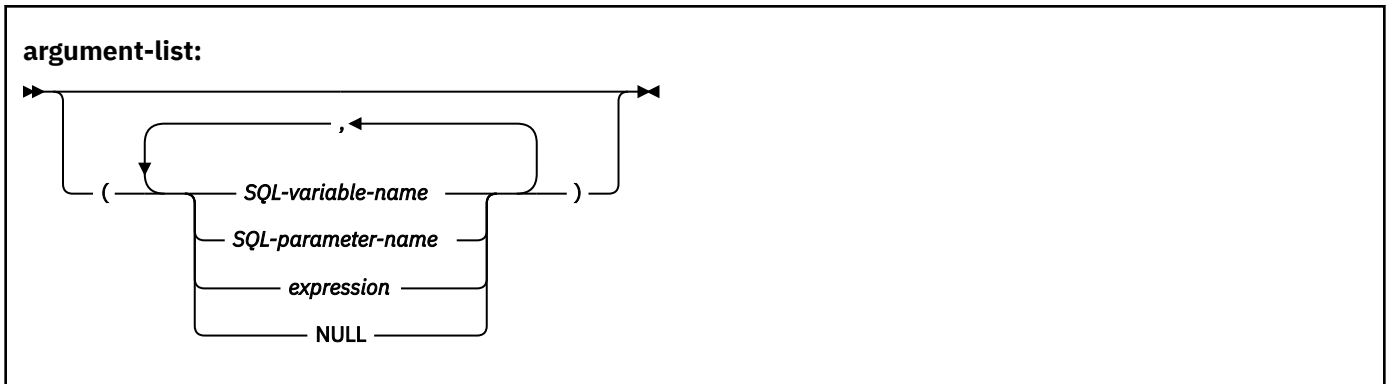

Description

procedure-name

Identifies the stored procedure to call. The procedure name must identify a stored procedure that exists at the current server.

argument-list

Identifies a list of values to be passed as parameters to the stored procedure. The number of parameters must be the same as the number of parameters defined for the stored procedure. See [“CALL statement”](#) on page 1384 for more information.

Control is passed to the stored procedure according to the calling conventions for SQL procedures. When execution of the stored procedure is complete, the value of each parameter of the stored procedure is assigned to the corresponding parameter of the CALL statement defined as OUT or INOUT.

SQL-variable-name

Specifies an SQL variable as an argument to the stored procedure. For an explanation of references to SQL variables, see [“References to SQL parameters and SQL variables in external SQL procedures”](#) on page 2280.

SQL-parameter-name

Specifies an SQL parameter as an argument to the stored procedure. For an explanation of references to SQL parameters, see [“References to SQL parameters and SQL variables in external SQL procedures”](#) on page 2280.

expression

The parameter is the result of the specified *expression*, which is evaluated before the stored procedure is invoked. If *expression* is a single *SQL-parameter-name* or *SQL-variable-name*, the corresponding parameter of the procedure can be defined as IN, INOUT, or OUT. Otherwise, the corresponding parameter of the procedure must be defined as IN. If the result of the *expression* can be the null value, either the description of the procedure must allow for null parameters or the corresponding parameter of the stored procedure must be defined as OUT.

The following additional rules apply depending on how the corresponding parameter was defined in the CREATE PROCEDURE statement for the procedure:

- IN *expression* can contain references to multiple SQL parameters or variables. In addition to the rules stated in [“Expressions”](#) on page 245 for *expression*, *expression* cannot include a column name, an aggregate function, or a user-defined function that is sourced on an aggregate function.
- INOUT or OUT *expression* can only be a single SQL parameter or variable.

NULL

The parameter is a null value. The corresponding parameter of the procedure must be defined as IN and the description of the procedure must allow for null parameters.

Notes

See “CALL statement” on page 1384 for more information on the SQL CALL statement.

Examples

Call stored procedure proc1 and pass SQL variables as parameters.

```
CALL proc1(v_empno, v_salary)
```

CASE statement

The CASE statement selects an execution path based on the evaluation of one or more conditions. A CASE statement operates in the same way as a CASE expression.

Syntax

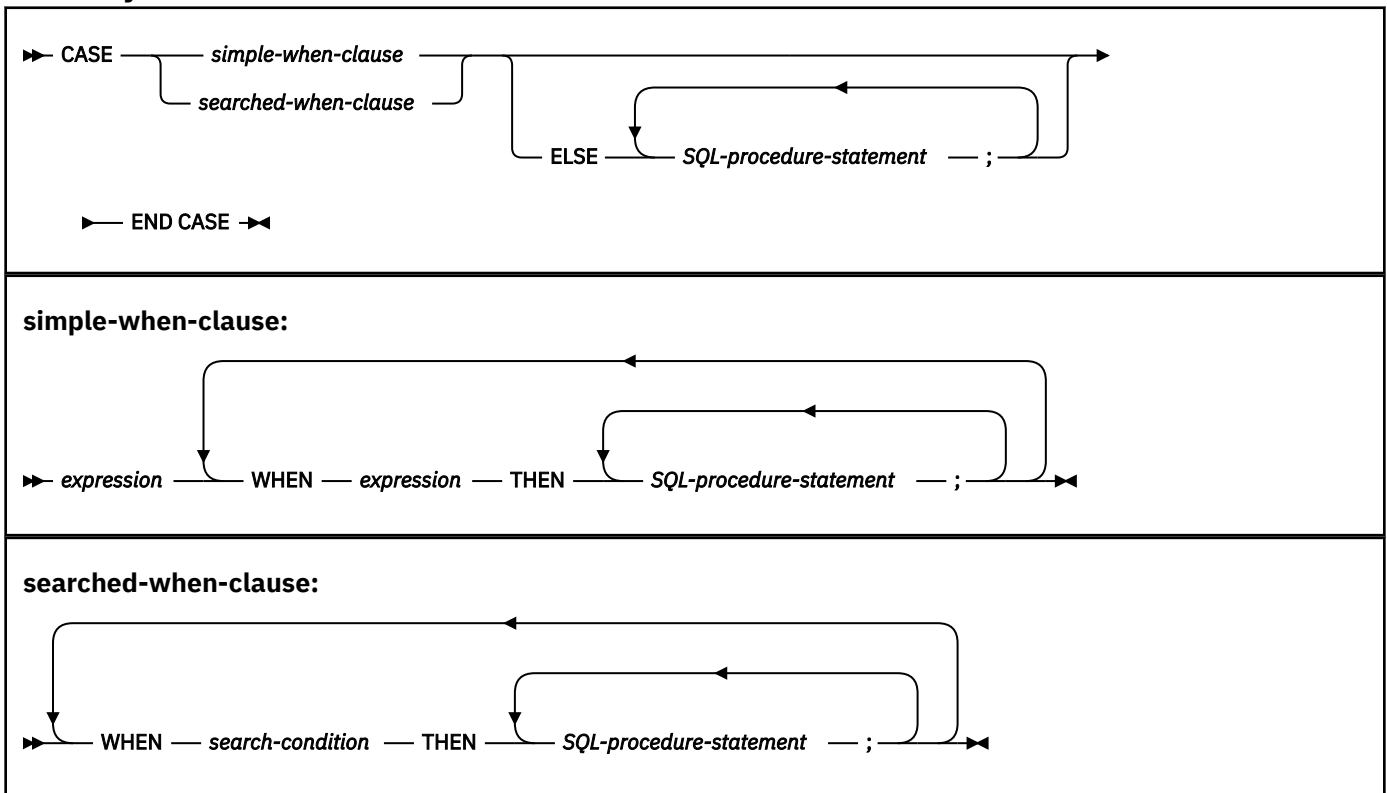

Description

CASE

Begins a *case-expression*.

simple-when-clause

Specifies the *expression* prior to the first WHEN keyword that is tested for equality with the value of each *expression* that follows the WHEN keyword, and the result to be executed when those expressions are equal. If the comparison is true, the THEN statement is executed. If the result is unknown or false, processing continues to the next expression or the ELSE statement.

The data type of the *expression* prior to the first WHEN keyword must be comparable to the data types of each *expression* that follows the WHEN keywords.

searched-when-clause

Specifies the *search-condition* that is applied to each row or group of table data presented for evaluation, and the result when that condition is true. *search-condition* cannot contain a *fullselect*. If

the search condition is true, the THEN statement is executed. If the condition is unknown or false, processing continues to the next search condition or the ELSE statement.

SQL-procedure-statement

Specifies a statement that follows the THEN and ELSE keyword. The statement specifies the result of a *searched-when-clause* or a *simple-when-clause* that is true, or the result if no case is true. The statement must be one of the statements listed under [“SQL-procedure-statement \(external\)”](#) on page 2280.

search-condition

Specifies a condition that is true, false, or unknown about a row or group of table data.

ELSE SQL-procedure-statement

If none of the conditions specified in the *simple-when-clause* or *searched-when-clause* are true, the statements in the *else-clause* are executed.

If none of the conditions specified in the WHEN clause are true and an ELSE clause is not specified, an error is returned at run time, and the execution of the CASE statement is terminated.

END CASE

Ends a *case-statement*.

Notes

If none of the conditions specified in the WHEN clause are true and an ELSE clause is not specified, an error is returned at run time, and the execution of the CASE statement is terminated.

CASE statements that use a simple case statement WHEN clause can be nested up to three levels. CASE statements that use a searched statement WHEN clause have no limit to the number of nesting levels.

Considerations for the SQLSTATE and SQLCODE SQL variables: When the first SQL-procedure-statement in the CASE statement is executed, the SQLSTATE and SQLCODE SQL variables reflect the result of evaluating the expression or search conditions of that CASE statement. If a CASE statement does not include an ELSE clause and none of the search conditions evaluate to true, an error is returned.

Examples

Example 1: Use a simple case statement WHEN clause to update column DEPTNAME in table DEPT, depending on the value of SQL variable *v_workdept*.

```
CASE v_workdept
  WHEN 'A00'
    THEN UPDATE DEPT SET
      DEPTNAME = 'DATA ACCESS 1';
  WHEN 'B01'
    THEN UPDATE DEPT SET
      DEPTNAME = 'DATA ACCESS 2';
  ELSE UPDATE DEPT SET
      DEPTNAME = 'DATA ACCESS 3';
END CASE
```

Example 2: Use a searched case statement WHEN clause to update column DEPTNAME in table DEPT, depending on the value of SQL variable *v_workdept*.

```
CASE
  WHEN v_workdept < 'B01'
    THEN UPDATE DEPT SET
      DEPTNAME = 'DATA ACCESS 1';
  WHEN v_workdept < 'C01'
    THEN UPDATE DEPT SET
      DEPTNAME = 'DATA ACCESS 2';
  ELSE UPDATE DEPT SET
      DEPTNAME = 'DATA ACCESS 3';
END CASE
```

compound-statement

A compound statement contains a group of statements and declarations for SQL variables, cursors, and condition handlers.

Syntax

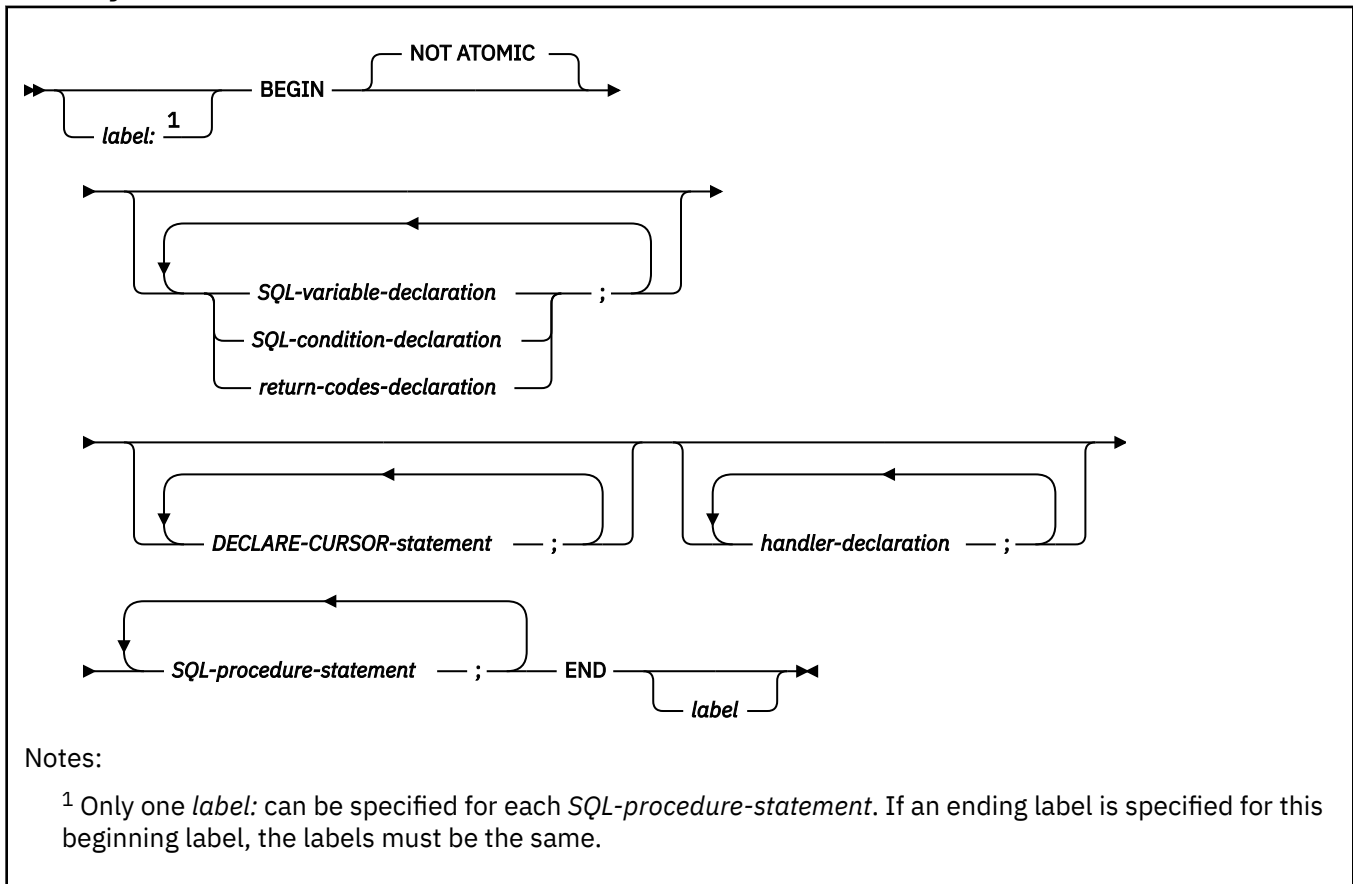

SQL-variable-declaration:

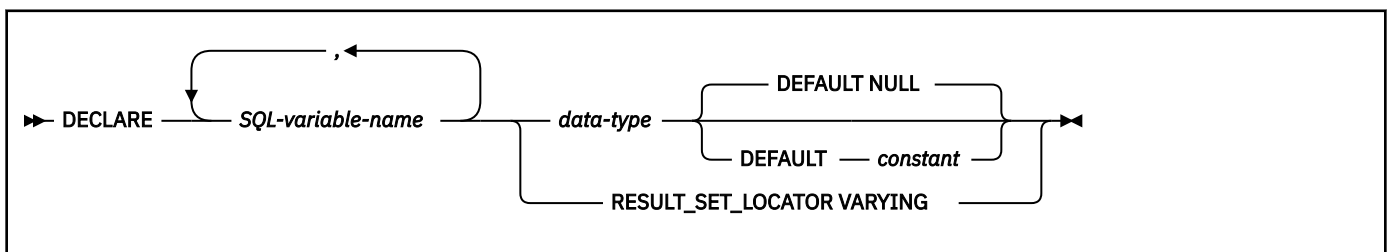

SQL-condition-declaration:

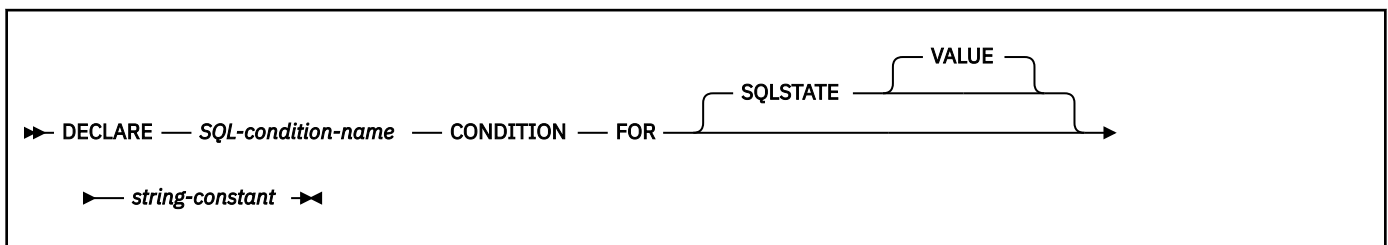

return-codes-declaration:

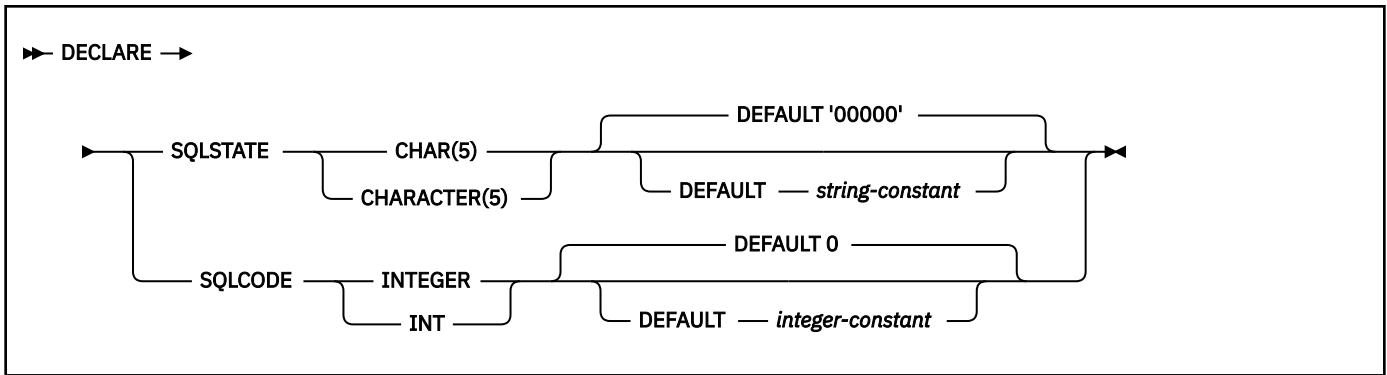

handler-declaration:

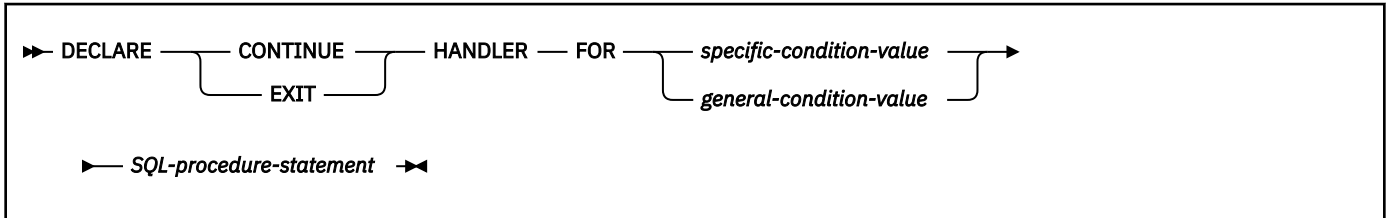

specific-condition-value:

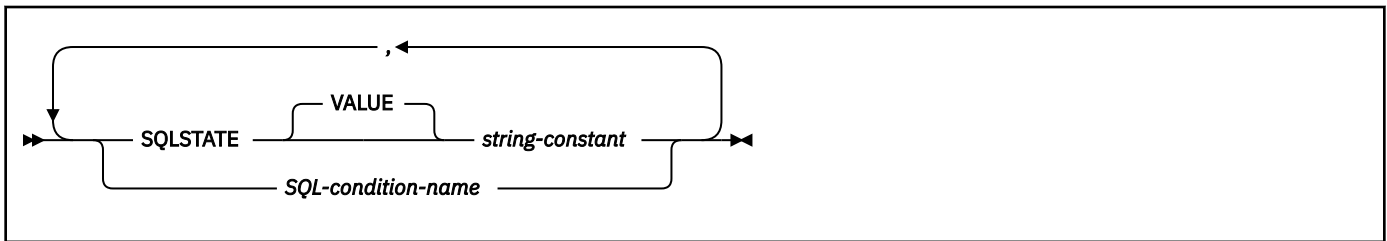

general-condition-value:



Description

label

Defines the label for the code block. If the beginning label is specified, it can be used to qualify SQL variables declared in the compound statement and can also be specified on a LEAVE statement. If the ending label is specified, it must be the same as the beginning label.

NOT ATOMIC

NOT ATOMIC indicates that an error within the compound statement does not cause the compound statement to be rolled back.

SQL-variable-declaration

Declares a variable that is local to the compound statement.

SQL-variable-name

A qualified or unqualified name that designates a variable in an SQL procedure body. The unqualified form of *SQL-variable-name* is an SQL identifier and must not be a delimited identifier that contains lowercase letters or special characters. The qualified form is an SQL procedure statement label followed by a period (.) and an SQL identifier.

Db2 folds all SBCS SQL variable names to uppercase. SQL variable names should not be the same as column names. If an SQL statement contains an SQL variable or parameter and a column reference with the same name, Db2 interprets the name as an SQL variable or parameter name. To refer to the column, qualify the column name with the table name. Further, to avoid ambiguous variable references and to ensure compatibility with other Db2 platforms, qualify the SQL variable or parameter name with the label of the SQL procedure statement.

data-type

Specifies the data type and length of the variable. SQL variables follow the same rules for default lengths and maximum lengths as SQL procedure parameters. See [“CREATE PROCEDURE statement \(SQL - external procedure\) \(deprecated\)”](#) on page 1597 for a description of SQL data types and lengths.

DEFAULT *constant* or NULL

Defines the default for the SQL variable. The variable is initialized when the SQL procedure is called. If a default value is not specified, the variable is initialized to NULL.

RESULT_SET_LOCATOR VARYING

Specifies the data type for a result set locator variable.

SQL-condition-declaration

Declares a condition name and corresponding SQLSTATE value.

SQL-condition-name

Specifies the name of the condition. The condition name is an SQL identifier and must not be a delimited identifier that includes lowercase letters or special characters. *SQL-condition-name* must be unique within the procedure body and can be referenced only within the compound statement in which it is declared.

FOR SQLSTATE *string-constant*

Specifies the SQLSTATE that is associated with the condition. The string must be specified as five characters enclosed in single quotes, and cannot be '00000'.

return-codes-declaration

Declares special variables called SQLSTATE and SQLCODE that are set automatically to the value returned after processing an SQL statement. Both the SQLSTATE and SQLCODE variables can be declared only in the outermost compound statement of the SQL procedure. Assignment to these variables is not prohibited; however, assignment is ignored by exception handlers, and processing the next SQL statement replaces the assigned value.

DECLARE-CURSOR-statement

Declares a cursor. Each cursor in the procedure body must have a unique name. An OPEN statement must be specified to open the cursor, and a FETCH statement can be specified to read rows. The cursor can be referenced only from within the compound statement. For more information on declaring a cursor, see [“DECLARE CURSOR statement”](#) on page 1819.

handler-declaration

Specifies a set of statements to execute when an exception or completion condition occurs in the compound statement. *SQL-procedure-statement* is the set of statements that execute when the handler receives control. See [“SQL-procedure-statement \(external\)”](#) on page 2280 for information on *SQL-procedure-statement*.

A handler is active only within the compound statement in which it is declared.

The actions that a handler can perform are:

CONTINUE

Specifies that after the condition handler is activated and completes successfully, control is returned to the SQL statement that follows the statement that raised the condition. However, if the condition is an error condition and it was encountered while evaluating a search condition, as in a CASE, IF, REPEAT or WHILE statement, control returns to the statement that follows the corresponding END CASE, END IF, END REPEAT, or END WHILE.

EXIT

After the handler is invoked successfully, control is returned to the end of the compound statement.

The conditions that can cause the handler to gain control are:

SQLSTATE *string-constant*

Specifies an SQLSTATE for which the handler is invoked. The SQLSTATE cannot be '00000'.

SQL-condition-name

Specifies a condition name for which the handler is invoked. The condition name must be previously defined in a condition declaration.

SQLEXCEPTION

Specifies that the handler is invoked when an SQLEXCEPTION occurs. An SQLEXCEPTION is an SQLSTATE in which the class code is a value other than '00', '01', or '02'. For more information on SQLSTATE values, see [SQLSTATE values and common error codes \(Db2 Codes\)](#).

SQLWARNING

Specifies that the handler is invoked when an SQLWARNING occurs. An SQLWARNING is an SQLSTATE value with a class code of '01'.

NOT FOUND

Specifies that the handler is invoked when a NOT FOUND condition occurs. NOT FOUND corresponds to an SQLSTATE value with a class code of '02'.

Notes

The order of statements in a compound statement must be:

1. SQL variable, condition declarations, and return codes declarations
2. Cursor declarations
3. Handler declarations
4. SQL procedure statements

Compound statements cannot be nested.

Unlike host variables, SQL variables are not preceded by colons when they are used in SQL statements.

The following rules apply to handlers:

- A handler declaration that contains SQLEXCEPTION, SQLWARNING, or NOT FOUND cannot contain additional SQLSTATE or condition names.
- Handler declarations within the same compound statement cannot contain duplicate conditions.
- A handler declaration cannot contain the same condition code or SQLSTATE value more than once, and cannot contain an SQLSTATE value and a condition name that represent the same SQLSTATE value.
- A handler is activated when it is the most appropriate handler for an exception or completion condition.
- If there is no handler for an SQL error, the error is passed to the caller in the SQLCA.
- A handler cannot be activated by an assignment statement that assigns a value to SQLSTATE.

The following rules and recommendations apply to the SQLCODE and SQLSTATE SQL variables:

- A null value cannot be assigned to SQLSTATE or SQLCODE.
- The SQLSTATE and SQLCODE variable values should be saved immediately to temporary variables if there is any intention to use the values. If a handler exists for SQLSTATE, this assignment must be done as the first statement to be processed in the handler to avoid having the value replaced by the next SQL procedure statement. If the condition raised by the SQL statement is handled, the value is changed by the first SQL statement contained in the handler.

Considerations for the SQLSTATE and SQLCODE SQL variables: The compound statement itself does not affect the SQLSTATE and SQLCODE SQL variables. However, SQL statements contained within the compound statement can affect the SQLSTATE and SQLCODE SQL variables. At the end of the compound

statement, the SQLSTATE and SQLCODE SQL variables reflect the result of the last SQL statement executed within the compound statement that caused a change to the SQLSTATE and SQLCODE SQL variables. If the SQLSTATE and SQLCODE SQL variables were not changed within the compound statement, they contain the same values as when the compound statement was entered.

Examples

Create a procedure body with a compound statement that performs the following actions:

- Declares SQL variables, a condition for SQLSTATE '02000', a handler for the condition, and a cursor
- Opens the cursor, fetches a row, and closes the cursor

```
CREATE PROCEDURE PROC1(OUT NOROWS INT) LANGUAGE SQL
BEGIN
  DECLARE v_firstnme VARCHAR(12);
  DECLARE v_midinit CHAR(1);
  DECLARE v_lastname VARCHAR(15);
  DECLARE v_edlevel SMALLINT;
  DECLARE v_salary DECIMAL(9,2);
  DECLARE at_end INT DEFAULT 0;
  DECLARE not_found
    CONDITION FOR '02000';
  DECLARE c1 CURSOR FOR
    SELECT FIRSTNME, MIDINIT, LASTNAME,
      EDLEVEL, SALARY
    FROM EMP;
  DECLARE CONTINUE HANDLER FOR not_found SET NOROWS=1;
  OPEN c1;
  FETCH c1 INTO v_firstnme, v_midinit,
    v_lastname, v_edlevel, v_salary;
END
```

GET DIAGNOSTICS statement

The GET DIAGNOSTICS statement obtains information about the previous SQL statement that was executed.

See [“GET DIAGNOSTICS statement” on page 1949](#).

When you need to specify a variable in a GET DIAGNOSTICS statement that is used within an SQL procedure, you would use either *SQL-variable-name* or *SQL-parameter-name*. In an embedded GET DIAGNOSTICS statement, you would use a *host-variable*. You can replace the instances of *host-variable* in the description of [“GET DIAGNOSTICS statement” on page 1949](#) with *SQL-variable-name* or *SQL-parameter-name*.

GOTO statement

The GOTO statement is used to branch to a user-defined label within an SQL procedure.

Syntax

```
►► GOTO — label ◀◀
```

Description

label

Specifies a labeled statement at which processing is to continue.

The labeled statement and the GOTO statement must be in the same scope. The following rules apply to the scope:

- If the GOTO statement is defined in a compound statement, *label* must be defined inside the same compound statement.

- If the GOTO statement is defined in a handler, *label* must be defined in the same handler and follow the other scope rules.
- If the GOTO statement is defined outside of a handler, *label* must not be defined within a handler.

If *label* is not defined within a scope that the GOTO statement can reach, an error is returned.

A label name cannot be the same as the name of the SQL procedure in which the label is used.

Notes

Use the GOTO statement sparingly. Because the GOTO statement interferes with the normal sequence of processing, it makes an SQL procedure more difficult to read and maintain. Before using a GOTO statement, determine whether some other statement, such as an IF statement or LEAVE statement, can be used instead.

Examples

Use a GOTO statement to transfer control to the end of a compound statement if the value of an SQL variable is less than 600.

```
BEGIN
  DECLARE new_salary DECIMAL(9,2);
  DECLARE service DECIMAL(8,2);
  SELECT SALARY, CURRENT_DATE - HIREDATE
     INTO new_salary, service
    FROM EMP
   WHERE EMPNO = v_empno;
  IF service < 600
    THEN GOTO EXIT;
  END IF;
  IF rating = 1
    THEN SET new_salary =
      new_salary + (new_salary * .10);
  ELSEIF rating = 2
    THEN SET new_salary =
      new_salary + (new_salary * .05);
  END IF;
  UPDATE EMP
   SET SALARY = new_salary
  WHERE EMPNO = v_empno;
EXIT: SET return_parm = service;
END
```

IF statement

The IF statement selects an execution path based on the evaluation of a condition.

Syntax

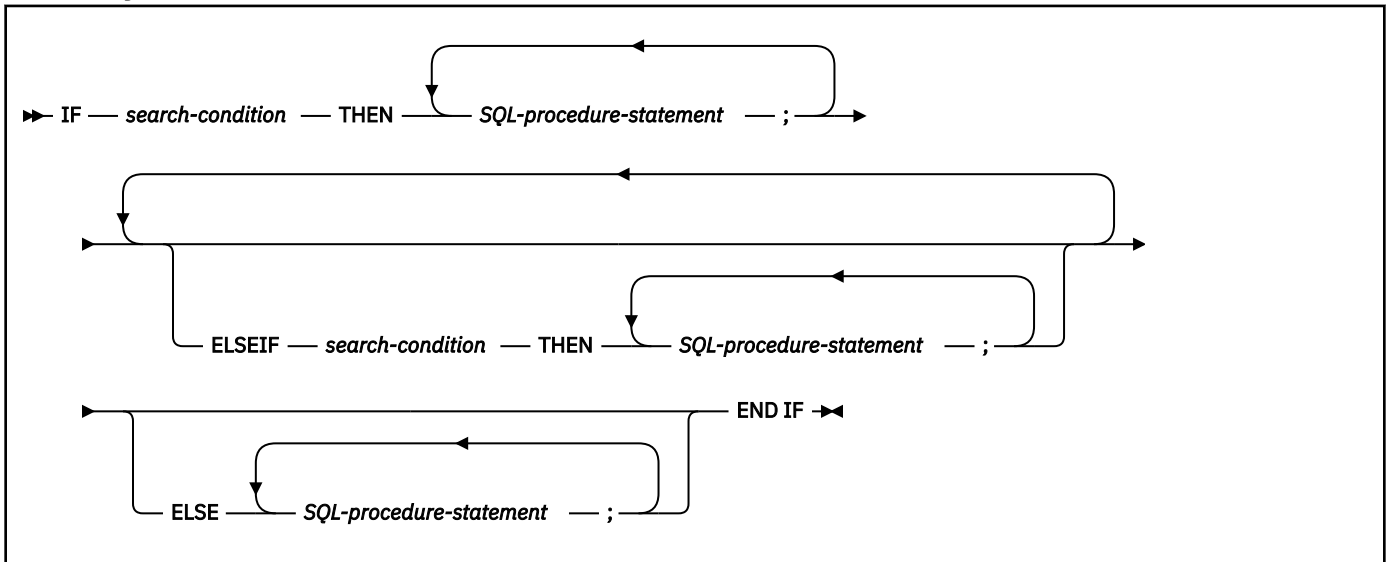

Description

search-condition

Specifies the condition for which an SQL statement should be invoked. If the condition is unknown or false, processing continues to the next search condition until either a condition is true or processing reaches the ELSE clause.

SQL-procedure-statement

Specifies the statement to be invoked if the preceding *search-condition* is true. If no *search-condition* evaluates to true, then the *SQL-procedure-statement* following the ELSE keyword is invoked. The statement must be one of the statements listed under [“SQL-procedure-statement \(external\)”](#) on page 2280.

Notes

Considerations for the SQLSTATE and SQLCODE SQL variables: When the first SQL-procedure-statement in the IF statement is executed, the SQLSTATE and SQLCODE SQL variables reflect the result of evaluating the search conditions of that IF statement. If an IF statement does not include an ELSE clause and none of the search conditions evaluate to true, then when the statement that follows that IF statement is executed, the SQLSTATE and SQLCODE SQL variables reflect the result of evaluating the search conditions of that IF statement.

Examples

Assign a value to the SQL variable *new_salary* based on the value of SQL variable *rating*.

```
IF rating = 1
  THEN SET new_salary =
    new_salary + (new_salary * .10);
  ELSEIF rating = 2
    THEN SET new_salary =
      new_salary + (new_salary * .05);
  ELSE SET new_salary =
    new_salary + (new_salary * .02);
END IF
```

ITERATE statement

The ITERATE statement causes the flow of control to return to the beginning of a labeled loop.

Syntax

```
▶▶ ITERATE — label ◀◀
```

Description

label

Specifies the label of the LOOP, REPEAT, or WHILE statement to which the flow of control is passed.

Examples

This example uses a cursor to return information for a new department. If the `not_found` condition handler is invoked, the flow of control passes out of the loop. If the value of `v_dept` is 'D11', an ITERATE statement causes the flow of control to be passed back to the top of the LOOP statement. Otherwise, a new row is inserted into the table.

```
CREATE PROCEDURE ITERATOR ()
LANGUAGE SQL
MODIFIES SQL DATA
BEGIN
  DECLARE v_dept CHAR(3);
  DECLARE v_deptname VARCHAR(29);
  DECLARE v_admdept CHAR(3);
  DECLARE at_end INTEGER DEFAULT 0;
  DECLARE not_found CONDITION FOR SQLSTATE '02000';
  DECLARE c1 CURSOR FOR
    SELECT deptno,deptname,admdept
      FROM department
     ORDER BY deptno;
  DECLARE CONTINUE HANDLER FOR not_found
  SET at_end = 1;
  OPEN c1;
  ins_loop:
  LOOP
    FETCH c1 INTO v_dept, v_deptname, v_admdept;
    IF at_end = 1 THEN
      LEAVE ins_loop;
    ELSEIF v_dept = 'D11' THEN
      ITERATE ins_loop;
    END IF;
    INSERT INTO department (deptno,deptname,admdept)
      VALUES('NEW', v_deptname, v_admdept);
  END LOOP;
  CLOSE c1;
END
```

LEAVE statement

The LEAVE statement transfers program control out of a loop or a compound statement.

Syntax

```
▶▶ LEAVE — label ◀◀
```

Description

label

Specifies the label of the compound statement or loop to exit.

A label name cannot be the same as the name of the SQL procedure in which the label is used.

Notes

When a LEAVE statement transfers control out of a compound statement, all open cursors in the compound statement, except cursors that are used to return result sets, are closed.

Examples

Use a LEAVE statement to transfer control out of a LOOP statement when a negative SQLCODE occurs.

```
ftch_loop: LOOP
  FETCH c1 INTO
    v_firstname, v_midinit,
    v_lastname, v_edlevel, v_salary;
  IF SQLCODE=100 THEN LEAVE ftch_loop;
END IF;
END LOOP
```

LOOP statement

The LOOP statement executes a statement or group of statements multiple times.

Syntax



Notes:

¹ Only one *label:* can be specified for each *SQL-procedure-statement*.

Description

label

Specifies the label for the LOOP statement. If the ending label is specified, the beginning label must be specified, and the two must match.

A label name cannot be the same as the name of the SQL procedure in which the label is used.

SQL-procedure-statement

Specifies the statements to be executed in the loop. The statement must be one of the statements listed under [“SQL-procedure-statement \(external\)”](#) on page 2280.

Examples

This procedure uses a LOOP statement to fetch values from the employee table. Each time the loop iterates, the OUT parameter counter is incremented and the value of *v_midinit* is checked to ensure that the value is not a single space (' '). If *v_midinit* is a single space, the LEAVE statement passes the flow of control outside of the loop.

```
CREATE PROCEDURE LOOP_UNTIL_SPACE(OUT counter INTEGER)
LANGUAGE SQL
BEGIN
  DECLARE v_counter INTEGER DEFAULT 0;
  DECLARE v_firstname VARCHAR(12);
  DECLARE v_midinit CHAR(1);
  DECLARE v_lastname VARCHAR(15);
  DECLARE c1 CURSOR FOR
    SELECT firstname, midinit, lastname
    FROM employee;
```

```

DECLARE EXIT HANDLER FOR NOT FOUND
  SET counter = -1;
OPEN c1;
fetch_loop:
LOOP
  FETCH c1 INTO v_firstname, v_midinit, v_lastname;
  IF v_midinit = ' ' THEN
    LEAVE fetch_loop;
  END IF;
  SET v_counter = v_counter + 1;
END LOOP fetch_loop;
SET counter = v_counter;
CLOSE c1;
END

```

REPEAT statement

The REPEAT statement executes a statement or group of statements until a search condition is true.

Syntax

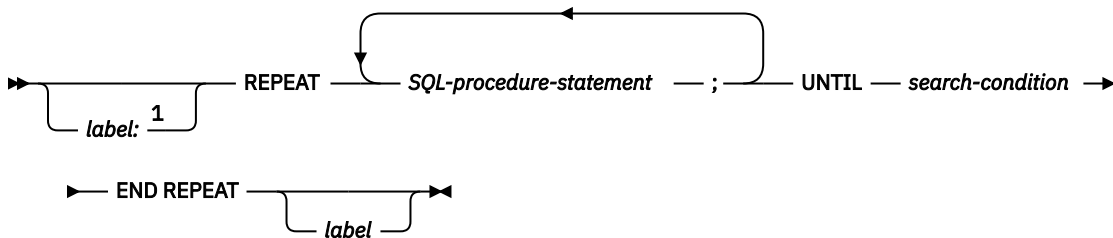

Notes:

¹ Only one *label:* can be specified for each *SQL-procedure-statement*.

Description

label

Specifies the label for the REPEAT statement. If the ending label is specified, the beginning label must be specified, and the two must match.

A label name cannot be the same as the name of the SQL procedure in which the label is used.

SQL-procedure-statement

Specifies the statements to be executed. The statement must be one of the statements listed under [“SQL-procedure-statement \(external\)”](#) on page 2280.

search-condition

Specifies a condition that is evaluated after each execution of the REPEAT statement. If the condition is true, the REPEAT loop will exit. If the condition is unknown or false, the REPEAT loop continues.

Examples

Use a REPEAT statement to fetch rows from a table.

```

fetch_loop:
REPEAT
  FETCH c1 INTO
    v_firstname, v_midinit, v_lastname;
UNTIL
  SQLCODE <> 0
END REPEAT fetch_loop

```

RESIGNAL statement

The RESIGNAL statement is used within a condition handler to re-raise the current condition, or to raise an alternate condition so that it can be processed at a higher level. It causes an exception, warning, or not found condition to be returned along with optional message text.

Issuing the RESIGNAL statement without an operand causes the current condition to be passed upwards.

Syntax

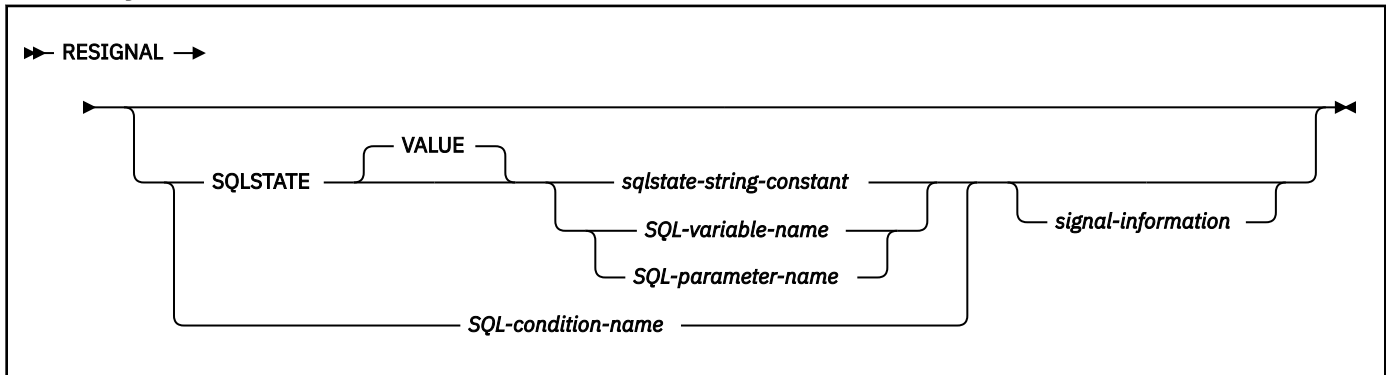

signal-information:

```
SET MESSAGE_TEXT = diagnostic-string-expression
```

Description

SQLSTATE VALUE

Specifies the SQLSTATE that will be returned. Any valid SQLSTATE value can be used. It must be a character string constant with exactly five characters that follow the rules for SQLSTATE values:

- Each character must be from the set of digits ('0' through '9') or non-accented upper case letter ('A' through 'Z').
- The SQLSTATE class (the first two characters) cannot be '00' because it represents successful completion.

If the SQLSTATE does not conform to these rules, an error occurs.

sqlstate-string-constant

A character string constant with a length of five bytes that is a valid SQLSTATE value.

SQL-variable-name or *SQL-parameter-name*

Specifies an SQL variable or SQL parameter that is defined for the procedure.

SQL-variable-name

Specifies an SQL variable that is declared within the *compound-statement* that contains the RESIGNAL statement. *SQL-variable-name* must be defined as CHAR or VARCHAR data type with a length of five bytes, must not be null, and must contain a valid SQLSTATE value.

SQL_parameter-name

Specifies an SQL parameter that is defined for the procedure that contains the SQLSTATE value. The SQL parameter must be defined as a CHAR or VARCHAR value and have a length of five bytes and must not be null. The SQL parameter must contain a valid SQLSTATE value.

SQL-condition-name

Specifies the name of the condition that will be returned. *condition-name* must be declared within the *compound-statement*.

SET MESSAGE_TEXT

Specifies a string that describes the error or warning. The string is returned in the SQLERRMC field of the SQLCA or with the GET DIAGNOSTICS statement.

diagnostic-string-expression

An expression with a data type of CHAR or VARCHAR that returns a character string of up to 1000 bytes that describes the error or warning condition. For information on how to obtain the complete message text, see [“GET DIAGNOSTICS statement” on page 1949](#).

Notes

While any valid SQLSTATE value can be used in the RESIGNAL statement, programmers should define new SQLSTATE values based on ranges reserved for applications. This practice prevents the unintentional use of an SQLSTATE value that might be defined by the database manager in a future release.

If the RESIGNAL statement is issued without an SQLSTATE clause or a *condition-name*, the RESIGNAL statement must be in a handler and the identical condition that activated the handler is returned. The SQLSTATE, SQLCODE, and the SQLCA associated with the condition are unchanged.

If an SQLSTATE clause or a *condition-name* was specified, the SQLCODE returned is based on the SQLSTATE value as follows:

- If the specified SQLSTATE class is either '01' or '02', a warning or not-found message is returned, and the SQLCODE is set to +438.
- Otherwise, an exception is returned and the SQLCODE is set to -438.

The other fields of the SQLCA are set as follows:

- SQLERRDx fields are set to zero.
- SQLWARNx fields are set to blank.
- SQLERRMC is set to the first 70 bytes of MESSAGE_TEXT.
- SQLERRML is set to the length of SQLERRMC.
- SQLERRP is set to ROUTINE.

When the SQLSTATE or condition indicates that an exception is returned (an SQLSTATE class other than '01' or '02'), the exception is not handled, and control is immediately returned to the end of the compound statement.

When the SQLSTATE or condition indicates that a warning (SQLSTATE class '02') is returned, the warning is not handled, and processing continues with the next statement.

When the SQLSTATE or condition indicates that a not-found condition (SQLSTATE class '02') is returned, the not-found condition is not handled, and processing continues with the next statement.

Examples

The following example detects a division by zero error. The IF statement uses a SIGNAL statement to invoke the overflow condition handler. The condition handler uses a RESIGNAL statement to return a different SQLSTATE to the client application.

```
CREATE PROCEDURE divide ( IN numerator INTEGER,
                        IN denominator INTEGER,
                        OUT divide_result INTEGER)
LANGUAGE SQL
CONTAINS SQL
BEGIN
  DECLARE overflow CONDITION for SQLSTATE '22003' ;
  DECLARE CONTINUE HANDLER FOR overflow
    RESIGNAL SQLSTATE '22375';
  IF denominator = 0 THEN
    SIGNAL overflow;
  ELSE
    SET divide_result = numerator / denominator;
  END IF;
END
```

RETURN statement

The RETURN statement is used to return from the routine. For SQL functions, it returns the result of the function. For an SQL procedure, it optionally returns an integer status value.

Syntax



Description

expression

Specifies a value that is returned from the routine.

- If the routine is a function, *expression* must be specified and the value of *expression* must conform to the SQL assignment rules as described in [“Assignment and comparison”](#) on page 143. If the value is being assigned to a string variable, storage assignment rules apply.
- If the routine is a procedure, the data type of *expression* must be INTEGER. If *expression* evaluates to the null value, a value of 0 is returned.

The *expression* cannot include a column name or a host variable. See [“Expressions”](#) on page 245 for information on expressions. The *expression* cannot contain a scalar fullselect.

NULL

The null value is returned from the SQL function. NULL is not allowed in SQL procedures.

Notes

When a RETURN statement is not used within an SQL procedure or when no value is specified: If a RETURN statement was not used to return from a procedure or if a value is not specified on the RETURN statement, one of the following values is set:

- If the procedure returns with an SQLCODE that is greater or equal to zero, the return status is set to a value of '0'.
- If the procedure returns with an SQLCODE that is less than zero, the return status is set to a value of '-1'.

When a RETURN statement is used within an SQL procedure: If a RETURN statement with a specified return value was used to return from a procedure, the SQLCODE, SQLSTATE, and message length in the SQLCA are initialized to zeros and the message text is set to blanks. An error is not returned to the caller.

When the value is returned: When a value is returned from a procedure, the caller may access the value using one of the following methods:

- The GET DIAGNOSTICS statement to retrieve the RETURN_STATUS when the SQL procedure was called from another SQL procedure.
- The parameter bound for the return value parameter marker in the escape clause CALL syntax (? =CALL...) in a CLI application.
- Directly from the SQLCA returned from processing the CALL of an SQL procedure by retrieving the value of sqlerrd[0]. When the SQLCODE is less than zero, the sqlerrd[0] value is not set. The application should assume a return status value of '-1'.

Examples

Use a RETURN statement to return from an SQL procedure with a status value of zero if successful or '-200' if not successful.

```
BEGIN
    . . . GOTO FAIL;
    SUCCESS: RETURN 0;
    FAIL: RETURN -200;
END
```

SIGNAL statement

The SIGNAL statement is used to return an error or warning condition. It causes an error or warning to be returned with the specified SQLSTATE, along with optional message text.

Syntax

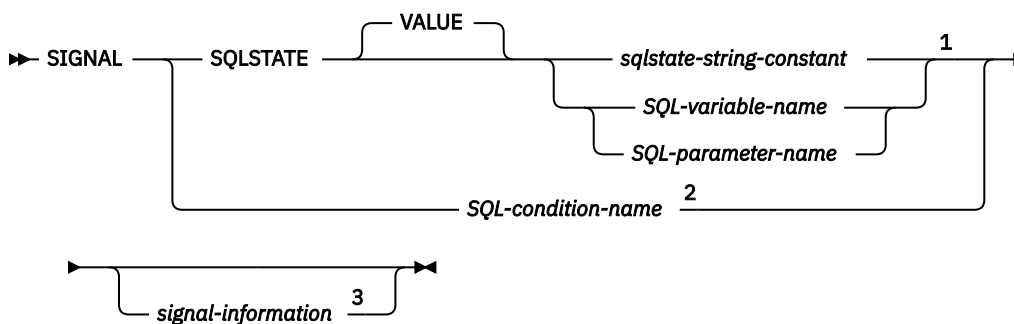

Notes:

- ¹ The SQLSTATE variation must be used within a trigger body.
- ² *SQL-condition-name* must not be specified within a trigger body.
- ³ *signal-information* must be specified within a trigger body

signal-information:

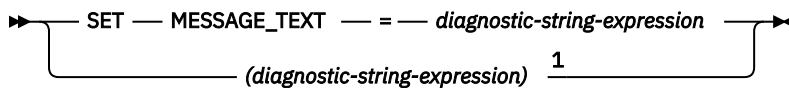

Notes:

- ¹ (*diagnostic-string-expression*) must only be specified within a trigger body.

Description

SQLSTATE VALUE

Specifies the SQLSTATE that will be returned. Any valid SQLSTATE value can be used. It must be a character string constant with exactly five characters that follow the rules for SQLSTATES:

- Each character must be from the set of digits ('0' through '9') or non-accented upper case letter ('A' through 'Z').
- The SQLSTATE class (the first two characters) cannot be '00' because it represents successful completion.

If the SQLSTATE does not conform to these rules, an error occurs.

sqlstate-string-constant

A character string constant with a length of five bytes that is a valid SQLSTATE value.

SQL-variable-name or SQL-parameter-name

Specifies an SQL variable or SQL parameter that contains a valid SQLSTATE value.

SQL-variable-name

Specifies an SQL variable that is declared within the *compound-statement*. *SQL-variable-name* must be defined as a CHAR or VARCHAR data type, have a length of five bytes, must not be null, and must contain a valid SQLSTATE value.

SQL-parameter-name

Specifies an SQL parameter that is defined for the procedure and contains the SQLSTATE value. The SQL parameter must be defined as a CHAR or VARCHAR value, have a length of five bytes, must not be null, and must contain a valid SQLSTATE value.

SQL-condition-name

Specifies the name of the condition that will be returned. *condition-name* must be declared within the *compound-statement*.

SET MESSAGE_TEXT

Specifies a string that describes the error or warning. The string is returned in the SQLERRMC field of the SQLCA or with the GET DIAGNOSTICS statement.

diagnostic-string-expression

An expression with a data type of CHAR or VARCHAR that returns a character string of up to 1000 bytes that describes the error or warning condition. For information on how to obtain the complete message text, see [“GET DIAGNOSTICS statement” on page 1949](#).

(diagnostic-string-expression)

An expression with a data type of CHAR or VARCHAR that returns a character string of up to 1000 bytes that describes the error or warning condition. For information on how to obtain the complete message text, see [“GET DIAGNOSTICS statement” on page 1949](#).

This syntax variation is only provided within the scope of a CREATE TRIGGER statement for compatibility with previous versions of Db2. To conform with the ANS and ISO standards, this form should not be used.

Notes

While any valid SQLSTATE value can be used in the SIGNAL statement, programmers should define new SQLSTATEs based on ranges reserved for applications. This practice prevents the unintentional use of an SQLSTATE value that might be defined by the database manager in a future release.

If a SIGNAL statement is issued, the SQLCODE that is returned is based on the SQLSTATE as follows:

- If the specified SQLSTATE class is either '01' or '02', a warning or not-found message is returned, and the SQLCODE is set to +438.
- Otherwise, an exception is returned and the SQLCODE is set to -438.

The other fields of the SQLCA are set as follows:

- SQLERRDx fields are set to zero.
- SQLWARNx fields are set to blank.
- SQLERRMC is set to the first 70 bytes of MESSAGE_TEXT.
- SQLERRML is set to the length of SQLERRMC.
- SQLERRP is set to ROUTINE.

When the SQLSTATE or condition indicates that an exception (an SQLSTATE class other than '01' or '02') is returned, one of the following actions occurs:

- If a handler exists for the specified SQLSTATE, condition, or SQLEXCEPTION, the exception is handled, and control is transferred to that handler.

- Otherwise, the exception is not handled, and control is immediately returned to the end of the compound statement.

When the SQLSTATE or condition indicates that a warning (SQLSTATE class '01') is returned, one of the following actions occurs:

- If an active handler exists for the specified SQLSTATE, condition, or SQLWARNING, the warning is handled, and control is transferred to that handler.
- Otherwise, the warning is not handled, and processing continues with the next statement.

When the SQLSTATE or condition indicates that a not-found condition (SQLSTATE class '02') is returned, one of the following actions occurs:

- If an active handler exists for the specified SQLSTATE, condition, or not-found condition, the not-found condition is handled, and control is transferred to that handler.
- Otherwise, the not-found condition is not handled, and processing continues with the next statement.

When the SIGNAL statement is issued in a handler, no active handler exists.

Using a SIGNAL statement in the body of a trigger: Within the triggered action of a CREATE TRIGGER statement, the message text can be specified using only these variations:

```
SIGNAL SQLSTATE sqlstate-string-constant
      SET MESSAGE_TEXT = diagnostic-string-expression
SIGNAL SQLSTATE sqlstate-string-constant
      (diagnostic-string-expression)
```

Examples

Example 1: The following example shows an SQL procedure for an order system that signals an application error when a customer number is not known to the application. The ORDERS table includes a foreign key to the CUSTOMER table, requiring that the CUSTNO exist before an order can be inserted.

```
CREATE PROCEDURE SUBMIT_ORDER
      (IN ONUM INTEGER, IN CNUM INTEGER,
      IN PNUM INTEGER, IN QNUM INTEGER)
LANGUAGE SQL
SPECIFIC SUBMIT_ORDER
MODIFIES SQL DATA
BEGIN
  DECLARE EXIT HANDLER FOR SQLSTATE VALUE '23503'
    SIGNAL SQLSTATE '75002'
      SET MESSAGE_TEXT = 'Customer number is not known';
  INSERT INTO ORDERS (ORDERNO, CUSTNO, PARTNO, QUANTITY)
    VALUES (ONUM, CNUM, PNUM, QNUM);
END
```

Example 2: The following example shows a trigger for an order system that allows orders to be recorded in an ORDERS table (ORDERNO, CUSTNO, PARTNO, QUANTITY) only if there is sufficient stock in the PARTS tables. When there is insufficient stock for an order, SQLSTATE '75001' is returned along with an appropriate error description.

```
CREATE TRIGGER CK_AVAIL
NO CASCADE BEFORE INSERT ON ORDERS
REFERENCING NEW AS NEW_ORDER
FOR EACH ROW MODE DB2SQL
WHEN (NEW_ORDER.QUANTITY > (SELECT ON_HAND FROM PARTS
      WHERE NEW_ORDER.PARTNO = PARTS.PARTNO))
  BEGIN ATOMIC
    SIGNAL SQLSTATE '75001' ('Insufficient stock for order');
  END
```

WHILE statement

The WHILE statement repeats the execution of a statement or group of statements while a specified condition is true.

Syntax

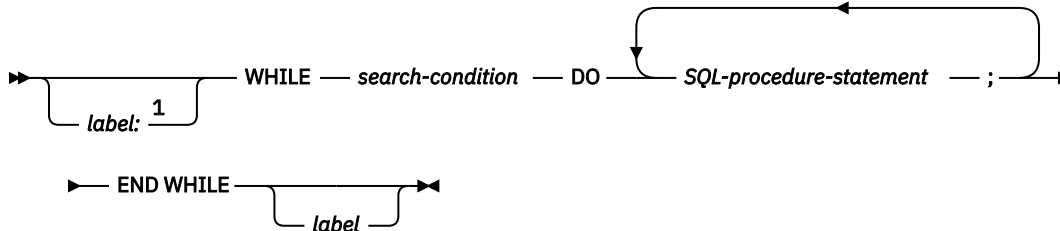

Notes:

¹ Only one *label*: can be specified for each *SQL-procedure-statement*. If an ending label is specified for this beginning label, the labels must be the same.

Description

label

Specifies the label for the WHILE statement. If the ending label is specified, it must be the same as the beginning label.

A label name cannot be the same as the name of the SQL procedure in which the label is used.

search-condition

Specifies a condition that is evaluated before each execution of the loop. If the condition is true, the SQL procedure statement in the loop is executed.

SQL-procedure-statement

Specifies the statements to be executed in the loop. The statement must be one of the statements listed under [“SQL-procedure-statement \(external\)”](#) on page 2280.

Examples

Use a WHILE statement to fetch rows from a table while SQL variable `at_end`, which indicates whether the end of the table has been reached, is 0.

```
WHILE at_end = 0 DO
  FETCH c1 INTO
    v_firstname, v_midinit,
    v_lastname, v_edlevel, v_salary;
  IF SQLCODE=100 THEN SET at_end=1;
END IF;
END WHILE
```

Appendix F. SQL communication area (SQLCA)

An SQLCA is a structure or collection of variables that is updated after each SQL statement executes. An application program that contains executable SQL statements must provide exactly one SQLCA, with a few exceptions.

The following exceptions exist:

- A program that is precompiled with the STDSQL(YES) option must not provide an SQLCA
- In some cases a Fortran program must provide more than one SQLCA.

In all host languages except REXX, the SQL INCLUDE statement can be used to provide the declaration of the SQLCA.

In COBOL and assembler:

The name of the storage area must be SQLCA.

In PL/I, and C:

The name of the structure must be SQLCA. Every executable SQL statement must be within the scope of its declaration.

Unless noted otherwise, C is used to represent C/370 and C/C++ programming languages.

In Fortran:

The name of the COMMON area for the INTEGER variables of the SQLCA must be SQLCA1; the name of the COMMON area for the CHARACTER variables must be SQLCA2. An SQLCA definition is required for every subprogram that contains SQL statements. One is also needed for the main program if it contains SQL statements.

In Java:

The DB2Sqlca class, which is an encapsulation of the SQLCA, should be used.

In REXX:

Db2 generates the SQLCA automatically. A REXX procedure cannot use the INCLUDE statement. The REXX SQLCA has a somewhat different format from SQLCAs for the other languages.

Related reference

[DB2Sqlca class \(Db2 Application Programming for Java\)](#)

[The REXX SQLCA](#)

The REXX SQLCA consists of a set of variables, rather than a structure. Db2 makes the SQLCA available to your application automatically.

Description of SQLCA fields

For the most part, COBOL, C, PL/I, and assembler use the same names for the SQLCA fields, and Fortran uses different names. However, there is one instance where C, PL/I, and assembler names differ from COBOL.

The names in the following table are those provided by the SQL INCLUDE statement.

Table 252. Fields of SQLCA

assembler, COBOL, or PL/I Name	C Name	Fortran Name	Data type	Purpose
SQLCAID	sqlcaid	Not used.	CHAR(8)	An "eye catcher" for storage dumps, containing the text 'SQLCA'. The sixth byte is 'L' if line number information is returned from parsing a dynamic statement or a native SQL procedure. The sixth byte is not set when processing an external SQL procedure.
SQLCABC	sqlcabc	Not used.	INTEGER	Contains the length of the SQLCA: 136.
SQLCODE (See note 1)	SQLCODE	SQLCOD	INTEGER	Contains the SQL return code. (See note 2) Code Means 0 Successful execution (though there might have been warning messages). positive Successful execution, but with a warning condition or other information. negative Error condition.
SQLERRML (See note 3)	sqlerrml (See note 3)	SQLTXL	SMALLINT	Length indicator for SQLERRMC, in the range 0 through 70. 0 means that the value of SQLERRMC is not pertinent.
SQLERRMC (See note 3)	sqlerrmc (See note 3)	SQLTXT	VARCHAR(70)	Contains one or more tokens, separated by X'FF', that are substituted for variables in the descriptions of error conditions. It may contain truncated tokens. A message length of 70 bytes indicates a possible truncation.
SQLERRP	sqlerrp	SQLERP	CHAR(8)	Provides a product signature and, in the case of an error, diagnostic information such as the name of the module that detected the error. In all cases, the first three characters are 'DSN' for Db2 for z/OS.
SQLERRD(1)	sqlerrd[0]	SQLERR(1)	INTEGER	For a sensitive static cursor, contains the number of rows in a result table when the cursor position is after the last row (that is, when SQLCODE is equal to +100). On successful return from an SQL procedure, contains the return status value from the SQL procedure. SQLERRD(1) can also contain an internal error code.

Table 252. Fields of SQLCA (continued)

assembler, COBOL, or PL/I Name	C Name	Fortran Name	Data type	Purpose
SQLERRD(2)	sqlerrd[1]	SQLERR(2)	INTEGER	<p>For a sensitive static cursor, contains the number of rows in a result table when the cursor position is after the last row (that is, when SQLCODE is equal to +100).</p> <p>SQLERRD(2) can also contain an internal error code.</p>
SQLERRD(3)	sqlerrd[2]	SQLERR(3)	INTEGER	<p>Contains the number of rows that qualified to be deleted, inserted, or updated after a DELETE, INSERT, UPDATE, or MERGE statement. The number excludes rows affected by triggers, referential integrity constraints, or inserted rows that are the result of processing a FOR PORTION OF clause for a BUSINESS_TIME period. For the OPEN of a cursor for a SELECT with a data change statement or for a SELECT INTO, SQLERRD(3) contains the number of rows affected by the embedded data change statement. The value is 0 if the SQL statement fails, indicating that all changes made in executing the statement canceled.</p> <p>For a DELETE statement the value will be -1 if the operation is a mass delete from a table in a segmented table space and the DELETE statement did not include selection criteria. If the delete was against a view, neither the DELETE statement nor the definition of the view included selection criteria.</p> <p>For a TRUNCATE statement, the value will be -1.</p> <p>For a PREPARE statement, contains the estimated number of rows selected. If the number of rows is greater than 2,147,483,647, a value of 2,147,483,647 is returned.</p> <p>For a REFRESH TABLE statement, SQLERRD(3) contains the number of rows inserted into the materialized query table.</p> <p>For a rowset-oriented FETCH, contains the number of rows fetched.</p>

Table 252. Fields of SQLCA (continued)

assembler, COBOL, or PL/I Name	C Name	Fortran Name	Data type	Purpose
SQLERRD(3) (continued)				<p>For SQLCODES -911 and -913, SQLERRD(3) contains the reason code for the timeout or deadlock.</p> <p>When an error is encountered in parsing a dynamic statement, or when parsing, binding, or executing a native SQL procedure, SQLERRD(3) will contain the line number where the error was encountered. The sixth byte of SQLCAID must be 'L' for this to be a valid line number. This value will be meaningful only if the statement source contains new line control characters. This information is not returned for an external SQL procedure.</p>
SQLERRD(4)	sqlerrd[3]	SQLERR(4)	INTEGER	<p>Generally, contains timerons, a short floating-point value that indicates a rough relative estimate of resources required (See note 4). It does not reflect an estimate of the time required. When preparing a dynamically defined SQL statement, you can use this field as an indicator of the relative cost of the prepared SQL statement. For a particular statement, this number can vary with changes to the statistics in the catalog. It is also subject to change between releases of Db2 for z/OS.</p>
SQLERRD(5)	sqlerrd[4]	SQLERR(5)	INTEGER	<p>Contains the position or column of a syntax error for a PREPARE or EXECUTE IMMEDIATE statement.</p>
SQLERRD(6)	sqlerrd[5]	SQLERR(6)	INTEGER	<p>Contains an internal error code.</p>
SQLWARN0	SQLWARN0	SQLWRN(0)	CHAR(1)	<p>Contains a blank if no other indicator is set to a warning condition (that is, no other indicator contains a W or Z). Contains a W if at least one other indicator contains a W or Z.</p>
SQLWARN1	SQLWARN1	SQLWRN(1)	CHAR(1)	<p>Contains a W if the value of a string column was truncated when assigned to a host variable. Contains an N for non-scrollable cursors and S for scrollable cursors after the OPEN CURSOR or ALLOCATE CURSOR statement.</p>
SQLWARN2	SQLWARN2	SQLWRN(2)	CHAR(1)	<p>Contains a W if null values were eliminated from the argument of an aggregate function; not necessarily set to W for the MIN function because its results are not dependent on the elimination of null values.</p>

Table 252. Fields of SQLCA (continued)

assembler, COBOL, or PL/I Name	C Name	Fortran Name	Data type	Purpose
SQLWARN3	SQLWARN3	SQLWRN(3)	CHAR(1)	Contains a W if the number of result columns is larger than the number of host variables. Contains a Z if fewer locators were provided in the ASSOCIATE LOCATORS statement than the stored procedure returned.
SQLWARN4	SQLWARN4	SQLWRN(4)	CHAR(1)	Contains a W if a prepared UPDATE or DELETE statement does not include a WHERE clause. For a scrollable cursor, contains a D for sensitive dynamic cursors, I for insensitive cursors, and S for sensitive static cursors after the OPEN CURSOR or ALLOCATE CURSOR statement; blank if cursor is not scrollable.
SQLWARN5	SQLWARN5	SQLWRN(5)	CHAR(1)	Contains a W if the SQL statement was not executed because it is not a valid SQL statement in Db2 for z/OS. Contains a character value of 1 (read only), 2 (read and delete), or 4 (read, delete, and update) to reflect capability of the cursor after the OPEN CURSOR or ALLOCATE CURSOR statement.
SQLWARN6	SQLWARN6	SQLWRN(6)	CHAR(1)	Contains a W if the addition of a month or year duration to a DATE or TIMESTAMP value results in an invalid day (for example, June 31). Indicates that the value of the day was changed to the last day of the month to make the result valid.
SQLWARN7	SQLWARN7	SQLWRN(7)	CHAR(1)	Contains a W if one or more nonzero digits were eliminated from the fractional part of a number used as the operand of a decimal multiply or divide operation.
SQLWARN8	SQLWARN8	SQLWRX(1)	CHAR(1)	Contains a W if a character that could not be converted was replaced with a substitute character. Contains a Y if there was an unsuccessful attempt to establish a trusted connection.
SQLWARN9	SQLWARN9	SQLWRX(2)	CHAR(1)	Contains a W if arithmetic exceptions were ignored during COUNT or COUNT_BIG processing. Contains a Z if the stored procedure returned multiple result sets.
SQLWARNA	SQLWARNA	SQLWRX(3)	CHAR(1)	Contains a W if at least one character field of the SQLCA or the SQLDA names or labels is invalid due to a character conversion error.
SQLSTATE	sqlstate	SQLSTT	CHAR(5)	Contains a return code for the outcome of the most recent execution of an SQL statement (See note 5).

Table 252. Fields of SQLCA (continued)

assembler, COBOL, or PL/I Name	C Name	Fortran Name	Data type	Purpose
--------------------------------------	-----------	-----------------	--------------	---------

Notes:

1. With the precompiler option STDSQL(YES) in effect, SQLCODE is replaced by SQLCADE in SQLCA.
2. For the specific meanings of SQL return codes, see [SQL codes \(Db2 Codes\)](#).
3. In COBOL, SQLERRM includes SQLERRML and SQLERRMC. In PL/I and C, the varying-length string SQLERRM is equivalent to SQLERRML prefixed to SQLERRMC. In assembler, the storage area SQLERRM is equivalent to SQLERRML and SQLERRMC. See the examples for the various host languages in [“The included SQLCA”](#) on page 2308.
4. The use of timerons may require special handling because they are floating-point values in an INTEGER array. In PL/I, for example, you could first copy the value into a BIN FIXED(31) based variable that coincides with a BIN FLOAT(24) variable.
5. For a description of SQLSTATE values, see [SQLSTATE values and common error codes \(Db2 Codes\)](#).

The included SQLCA

The description of the SQLCA that is given by INCLUDE SQLCA is shown for each of the host languages.

assembler:

```
SQLCA      DS      0F
SQLCAID   DS      CL8      ID
SQLCABC   DS      F        BYTE COUNT
SQLCODE   DS      F        RETURN CODE
SQLERRM   DS      H,CL70   ERR MSG PARMS
SQLERRP   DS      CL8      IMPL-DEPENDENT
SQLERRD   DS      6F
SQLWARN   DS      0C        WARNING FLAGS
SQLWARN0  DS      C'W'    IF ANY
SQLWARN1  DS      C'W'    = WARNING
SQLWARN2  DS      C'W'    = WARNING
SQLWARN3  DS      C'W'    = WARNING
SQLWARN4  DS      C'W'    = WARNING
SQLWARN5  DS      C'W'    = WARNING
SQLWARN6  DS      C'W'    = WARNING
SQLWARN7  DS      C'W'    = WARNING
SQLEXT   DS      0CL8
SQLWARN8  DS      C
SQLWARN9  DS      C
SQLWARNA  DS      C
SQLSTATE  DS      CL5
```

C:

```
#ifndef SQLCODE
struct sqlca
{
    unsigned char  sqlcaid[8];
    long           sqlcabc;
    long           sqlcode;
    short          sqlerrml;
    unsigned char  sqlerrmc[70];
    unsigned char  sqlerrp[8];
    long           sqlerrd[6];
    unsigned char  sqlwarn[11];
    unsigned char  sqlstate[5];
};
#define SQLCODE    sqlca.sqlcode
#define SQLWARN0   sqlca.sqlwarn[0]
#define SQLWARN1   sqlca.sqlwarn[1]
#define SQLWARN2   sqlca.sqlwarn[2]
```



```

#define SQLWARN3 sqlca.sqlwarn[3]
#define SQLWARN4 sqlca.sqlwarn[4]
#define SQLWARN5 sqlca.sqlwarn[5]
#define SQLWARN6 sqlca.sqlwarn[6]
#define SQLWARN7 sqlca.sqlwarn[7]
#define SQLWARN8 sqlca.sqlwarn[8]
#define SQLWARN9 sqlca.sqlwarn[9]
#define SQLWARNA sqlca.sqlwarn[10]
#define SQLSTATE sqlca.sqlstate
#endif
struct sqlca sqlca;

```

COBOL:

```

01 SQLCA.
  05 SQLCAID      PIC X(8).
  05 SQLCABC      PIC S9(9) COMP-5.
  05 SQLCODE      PIC S9(9) COMP-5.
  05 SQLERRM.
    49 SQLERRML   PIC S9(4) COMP-5.
    49 SQLERRMC   PIC X(70).
  05 SQLERRP      PIC X(8).
  05 SQLERRD      OCCURS 6 TIMES
                  PIC S9(9) COMP-5.
  05 SQLWARN.
    10 SQLWARN0   PIC X.
    10 SQLWARN1   PIC X.
    10 SQLWARN2   PIC X.
    10 SQLWARN3   PIC X.
    10 SQLWARN4   PIC X.
    10 SQLWARN5   PIC X.
    10 SQLWARN6   PIC X.
    10 SQLWARN7   PIC X.
  05 SQLEXT.
    10 SQLWARN8   PIC X.
    10 SQLWARN9   PIC X.
    10 SQLWARNA   PIC X.
    10 SQLSTATE   PIC X(5).

```

Fortran:

```

*
*   THE SQL COMMUNICATIONS AREA
*
  INTEGER      SQLCOD,
  C            SQLERR(6),
  C            SQLTXL*2
  COMMON /SQLCA1/SQLCOD, SQLERR,SQLTXL
  CHARACTER    SQLERP*8,
  C            SQLWRN(0:7)*1,
  C            SQLTXT*70,
  C            SQLEXT*8,
  C            SQLWRX(1:3)*1,
  C            SQLSTT*5
  COMMON /SQLCA2/SQLERP,SQLWRN,SQLTXT,SQLWRX,
  C            SQLSTT
  EQUIVALENCE (SQLWRX,SQLEXT)
*

```

PL/I:

```

DECLARE
  1 SQLCA,
  2 SQLCAID CHAR(8),
  2 SQLCABC FIXED(31) BINARY,
  2 SQLCODE FIXED(31) BINARY,
  2 SQLERRM CHAR(70) VAR,
  2 SQLERRP CHAR(8),
  2 SQLERRD(6) FIXED(31) BINARY,
  2 SQLWARN,
  3 SQLWARN0 CHAR(1),
  3 SQLWARN1 CHAR(1),
  3 SQLWARN2 CHAR(1),
  3 SQLWARN3 CHAR(1),
  3 SQLWARN4 CHAR(1),

```

```

3 SQLWARN5 CHAR(1),
3 SQLWARN6 CHAR(1),
3 SQLWARN7 CHAR(1),
2 SQLTEXT,
3 SQLWARN8 CHAR(1),
3 SQLWARN9 CHAR(1),
3 SQLWARNA CHAR(1),
3 SQLSTATE CHAR(5);

```

The REXX SQLCA

The REXX SQLCA consists of a set of variables, rather than a structure. Db2 makes the SQLCA available to your application automatically.

The following table lists the variables in a REXX SQLCA.

Table 253. Variables in a REXX SQLCA

Variable	Contents
SQLCODE	Contains the SQL return code.
SQLERRMC	Contains one or more tokens, separated by X'FF', that are substituted for variables in the descriptions of error conditions. It might contain truncated tokens. A message length of 70 bytes indicates a possible truncation.
SQLERRP	Provides a product signature and, in the case of an error, diagnostic information such as the name of the module that detected the error. For Db2 for z/OS, the product signature is 'DSN'.
SQLERRD.1	For a sensitive static cursor, contains the number of rows in a result table when the cursor position is after the last row (that is, when SQLCODE is equal to +100). SQLERRD(1) can also contain an internal error code.
SQLERRD.2	For a sensitive static cursor, contains the number of rows in a result table when the cursor position is after the last row (that is, when SQLCODE is equal to +100). SQLERRD(2) can also contain an internal error code.
SQLERRD.3	<p>Contains the number of rows that qualified for the operation after an SQL data change statement (but not rows deleted as a result of CASCADE delete). For the OPEN of a cursor for a SELECT with an SQL data change statement or for a SELECT INTO, SQLERRD(3) contains the number of rows affected by the embedded data change statement. Set to 0 if the SQL statement fails, indicating that all changes made in executing the statement were canceled. Set to -1 for a mass delete from a table in a segmented table space, for a truncate operation, or a delete from a view when neither the DELETE statement nor the definition of the view included selection criteria.</p> <p>For rowset-oriented FETCH statements, contains the number of rows returned in the rowset.</p> <p>For SQLCODES -911 and -913, SQLERRD(3) contains the reason code for the timeout or deadlock.</p> <p>After successful execution of the REFRESH TABLE statement, SQLERRD(3) contains the number of rows inserted into the materialized query table.</p> <p>When an error is encountered in parsing a dynamic statement, or when parsing, binding, or executing a native SQL procedure, SQLERRD(3) will contain the line number where the error was encountered. The sixth byte of SQLCAID must be 'L' for this to be a valid line number. This value will be meaningful only if the statement source contains new line control characters. This information is not returned for an external SQL procedure.</p>

Table 253. Variables in a REXX SQLCA (continued)

Variable	Contents
SQLERRD.4	Generally, contains timerons, a short floating-point value that indicates a rough relative estimate of resources required. This value does not reflect an estimate of the time required to execute the SQL statement. After you prepare an SQL statement, you can use this field as an indicator of the relative cost of the prepared SQL statement. For a particular statement, this number can vary with changes to the statistics in the catalog. This value is subject to change between releases of Db2 for z/OS.
SQLERRD.5	Contains the position or column of a syntax error for a PREPARE or EXECUTE IMMEDIATE statement.
SQLERRD.6	Contains an internal error code.
SQLWARN.0	Contains a blank if no other indicator is set to a warning condition (that is, no other indicator contains a W or Z). Contains a W if at least one other indicator contains a W or Z.
SQLWARN.1	Contains a W if the value of a string column was truncated when assigned to a host variable. Contains an N for non-scrollable cursors and S for scrollable cursors after the OPEN CURSOR or ALLOCATE CURSOR statement.
SQLWARN.2	Contains a W if null values were eliminated from the argument of an aggregate function; not necessarily set to W for the MIN function because its results are not dependent on the elimination of null values.
SQLWARN.3	Contains a W if the number of result columns is larger than the number of host variables. Contains Z if the ASSOCIATE LOCATORS statement contains fewer locators than the stored procedure returned.
SQLWARN.4	Contains a W if a prepared UPDATE or DELETE statement does not include a WHERE clause. For a scrollable cursor, contains a D for sensitive dynamic cursors, I for insensitive cursors, and S for sensitive static cursors after the OPEN CURSOR or ALLOCATE CURSOR statement; otherwise, blank if cursor is not scrollable.
SQLWARN.5	Contains a W if the SQL statement was not executed because it is not a valid SQL statement in Db2 for z/OS. Contains a character value of 1 (read only), 2 (read and delete), or 4 (read, delete, and update) to reflect capability of the cursor after the OPEN CURSOR or ALLOCATE CURSOR statement.
SQLWARN.6	Contains a W if the addition of a month or year duration to a DATE or TIMESTAMP value results in an invalid day (for example, June 31). Indicates that the value of the day was changed to the last day of the month to make the result valid.
SQLWARN.7	Contains a W if one or more nonzero digits were eliminated from the fractional part of a number that was used as the operand of a decimal multiply or divide operation.
SQLWARN.8	Contains a W if a character that could not be converted was replaced with a substitute character.
SQLWARN.9	Contains a W if arithmetic exceptions were ignored during COUNT or COUNT_BIG processing. Contains a Z if the stored procedure returned multiple result sets.
SQLWARN.10	Contains a W if at least one character field of the SQLCA is invalid due to a character conversion error.
SQLSTATE	Contains a return code for the outcome of the most recent execution of an SQL statement.

Appendix G. SQL descriptor area (SQLDA)

An SQLDA is a collection of variables that is required for execution of the SQL DESCRIBE statement, and can be optionally used by the PREPARE, OPEN, FETCH, EXECUTE, and CALL statements. An SQLDA can be used in a DESCRIBE or PREPARE INTO statement, modified with the addresses of host variables, and then reused in a FETCH statement.

The meaning of the information in an SQLDA depends on the context in which it is used. For DESCRIBE and PREPARE INTO, Db2 sets the fields in the SQLDA to provide information to the application program. For OPEN, EXECUTE, FETCH, and CALL, the application program sets the fields in the SQLDA to provide Db2 with information:

DESCRIBE *statement-name* or PREPARE INTO

With the exception of SQLN, Db2 sets fields of the SQLDA to provide information to an application program about a prepared statement. Each SQLVAR occurrence describes a column of the result table.

DESCRIBE TABLE

With the exception of SQLN, Db2 sets fields of the SQLDA to provide information to an application program about the columns of a table or view. Each SQLVAR occurrence describes a column of the specified table or view.

DESCRIBE CURSOR

With the exception of SQLN, Db2 sets fields of the SQLDA to provide information to an application program about the result set that is associated with the specified cursor. Each SQLVAR occurrence describes a column of the result set.

DESCRIBE INPUT

With the exception of SQLN, Db2 sets fields of the SQLDA to provide information to an application program about the input parameter markers of a prepared statement. Each SQLVAR occurrence describes an input parameter marker.

DESCRIBE PROCEDURE

With the exception of SQLN, Db2 sets fields of the SQLDA to provide information to an application program about the result sets returned by the specified stored procedure. Each SQLVAR occurrence describes a returned result set.

OPEN, EXECUTE, FETCH, and CALL

The application program sets fields of the SQLDA to provide information about host variables or output buffers in the application program to Db2. Each SQLVAR occurrence describes a host variable or output buffer.

- For OPEN and EXECUTE, each SQLVAR occurrence describes an input value that is substituted for a parameter marker in the associated SQL statement that was previously prepared.
- For FETCH, each SQLVAR occurrence describes a host variable or buffer in the application program that is to be used to contain an output value from a row of the result.
- For CALL, each SQLVAR occurrence describes a host variable that corresponds to a parameter in the parameter list for the stored procedure.

For information on the way to use the SQLDA, see [Defining SQL descriptor areas \(SQLDA\) \(Db2 Application programming and SQL\)](#).

Description of SQLDA fields

An SQLDA consists of four variables, a header, and an arbitrary number of occurrences of a sequence of variables collectively named SQLVAR.

In DESCRIBE and PREPARE INTO, each occurrence of the SQLVAR describes the column of a table. In FETCH, OPEN, EXECUTE, and CALL, each occurrence describes a host variable.

The order of the SQLVAR entries matches the order of the columns in the table or the order of the parameter markers in the SQL statement.

The SQLDA Header

The fields in the SQLDA header have different usage depending on whether the SQLDA is being used in a DESCRIBE or PREPARE INTO statement or the SQLDA is being used in a FETCH, INSERT, OPEN, EXECUTE, or CALL statement.

The following table describes the fields in the SQLDA header.

Table 254. Fields of the SQLDA header

C name assembler, COBOL or PL/I name	Data type	Usage in DESCRIBE ¹ and PREPARE INTO	Usage in FETCH,INSERT, OPEN, EXECUTE, and CALL
sqldaid SQLDAID	CHAR(8)	<p>An "eye catcher" for storage dumps, containing the text 'SQLDA '.</p> <p>The 7th byte of the field is a flag that can be used to determine if more than one SQLVAR entry is needed for each column. For details, see “Determining how many SQLVAR occurrences are needed” on page 2316.</p> <p>For DESCRIBE CURSOR, the field is set to 'SQLRS'. If the cursor is declared WITH HOLD in a stored procedure, the high-order bit of the 8th byte is set to 1.</p> <p>For DESCRIBE PROCEDURE, it is set to 'SQLPR'.</p>	<p>A plus sign (+) in the 6th byte indicates that SQLNAME contains an overriding CCSID.</p> <p>A '2' in the 7th byte indicates the two SQLVAR entries were allocated for each column or parameter.</p> <p>A '3' in the 7th byte indicates that three SQLVAR entries were allocated for each column or parameter. Although three entries are never needed on input to Db2, an SQLDA with three entries might be used when the SQLDA was initialized by a DESCRIBE or PREPARE INTO with a USING BOTH clause.</p> <p>Otherwise, SQLDAID is not used.</p>
sqldabc SQLDABC	INTEGER	Length of the SQLDA, equal to $SQLN \times 44 + 16$.	Length of the SQLDA, greater than or equal to $SQLN \times 44 + 16$.
sqln SQLN	SMALLINT	<p>Unchanged by Db2. The field must be set to a value greater than or equal to zero before the statement is executed. The field indicates the total number of occurrences of SQLVAR. At the very least, the number should be:</p> <ul style="list-style-type: none"> • For DESCRIBE INPUT, the number of parameter markers to be described. • For other DESCRIBEs or PREPARE INTO: the number of columns of the result, or a multiple of the columns of the result when there are multiple sets of SQLVAR entries because column labels are returned in addition to column names. 	Total number of occurrences of SQLVAR provided in the SQLDA. SQLN must be set to a value greater than or equal to zero.

Table 254. Fields of the SQLDA header (continued)

C name assembler, COBOL or PL/I name	Data type	Usage in DESCRIBE ¹ and PREPARE INTO	Usage in FETCH,INSERT, OPEN, EXECUTE, and CALL
sqlld SQLD	SMALLINT	<p>The number of columns described by occurrences of SQLVAR. Double that number if USING BOTH appears in the DESCRIBE or PREPARE INTO statement. Contains a 0 if the statement string is not a query.</p> <p>For DESCRIBE PROCEDURE, the number of result sets returned by the stored procedure. Contains a 0 if no result sets are returned.</p>	The number of host variables described by occurrences of SQLVAR.

Note:

- The third column of this table represents several forms of the DESCRIBE statement:
 - For DESCRIBE *output* and PREPARE INTO, the column pertains to columns of the result table.
 - For DESCRIBE CURSOR, the column pertains to a result set associated with a cursor.
 - For DESCRIBE INPUT, the column pertains to parameter markers.
 - For DESCRIBE PROCEDURE, the column pertains to the result sets returned by the stored procedure.

SQLVAR entries

For each column or host variable described by the SQLDA, there are both base SQLVAR entries and extended SQLVAR entries.

Base SQLVAR entry

The base SQLVAR entry is always present. The fields of this entry contain the base information about the column or host variable such as data type code, length attribute (except for LOBs), column name (or label), host variable address, and indicator variable address.

Extended SQLVAR entry

The extended SQLVAR entry is needed (for each column) if the result includes any LOB or distinct type³⁸ columns. For distinct types, the extended SQLVAR contains the distinct type name. For LOBs, the extended SQLVAR contains the length attribute of the host variable and a pointer to the buffer that contains the actual length. If locators are used to represent LOBs, an extended SQLVAR is not necessary.

The extended SQLVAR entry is also needed for each column when the USING BOTH clause was specified, which indicates that both columns names and labels are returned. The DESCRIBE *output* and PREPARE statements can include the USING BOTH clause.

The fields in the extended SQLVAR that return LOB and distinct type information do not overlap, and the fields that return LOB and label information do not overlap. Depending on the combination of labels, LOBs and distinct types, more than one extended SQLVAR entry per column may be required to return the information. See [“Determining how many SQLVAR occurrences are needed” on page 2316](#).

The following table shows how to map the base and extended SQLVAR entries. For an SQLDA that contains both base and extended SQLVAR entries, the base SQLVAR entries are in the first block, followed by a block of extended SQLVAR entries, which if necessary, are followed by a second block of extended

³⁸ DESCRIBE INPUT does not return information about distinct types.

SQLVAR entries. In each block, the number of occurrences of the SQLVAR entry is equal to the value in SQLD³⁹ even though many of the extended SQLVAR entries might be unused.

Table 255. Contents of SQLVAR arrays

LOBs	Distinct types ¹	7th byte of SQLDAID	SQLD	Minimum for SQLN ²	Set of SQLVAR entries		
					First set (Base)	Second set (Extended)	Third set (Extended)
USING BOTH clause not specified:							
No	No	Space	n	n	Column names, labels	Not Used	Not Used
Yes ³	Yes ³	2	n	$2n$	Column names, labels	LOBs, distinct types, or both	Not used
USING BOTH clause was specified:							
No	No	Space	$2n$	$2n$	Column names	Labels	Not used
Yes	No	2	n	$2n$	Column names	LOBs and labels	Not used
No	Yes	3	n	$3n$	Column names	Distinct types	Labels
Yes	Yes	3	n	$3n$	Column names	LOBs and distinct types	Labels

Notes:

1. DESCRIBE INPUT does not return information about distinct types.
2. The number of columns or host variables that the SQLDA describes.
3. Either LOBs, distinct types, or both are present.
4. Here, the 7th byte is set to a space and SQLD is set to two times the number of columns in the result. For all other values of the 7th byte for USING BOTH, SQLD is set to the number of columns in the result, and the 7th byte can be used to determine how many SQLVAR entries are needed for each column of the result.

Determining how many SQLVAR occurrences are needed

The number of SQLVAR occurrences needed depends on the statement that the SQLDA was provided for and the data types of the columns or parameters being described.

If the USING BOTH clause was not specified for the statement and neither LOBs nor distinct types are present in the result, only one SQLVAR entry (a base entry) is needed for each column. The 7th byte of SQLDAID is set to a space. The SQLD is set to the number of columns in the result and represents the number of SQLVAR occurrences needed. If an insufficient number of SQLVAR occurrences were provided, Db2 returns a +236 warning in SQLCODE if the standards option was set. Otherwise, SQLCODE is zero.

If USING BOTH is specified and neither LOBs nor distinct types are present in the result, an extended SQLVAR entry per column is needed for the labels in addition to the base SQLVAR entry. The 7th byte of the SQLDAID is set to space. SQLD is set to the twice the number of columns in the result and represents the combined number of base and extended SQLVAR occurrences needed.

³⁹ When an extended SQLVAR entry is present for each column for *labels* (and there are no LOB or distinct type columns in the result),

If LOBs, distinct types, or both are present in the results, one extended SQLVAR entry is needed per column in addition to the base SQLVAR entry with one exception. The exception is that when the USING BOTH clause is specified and distinct types are present in the results, two extended SQLVAR entries per column are needed. When a sufficient number of SQLVAR entries are provided in the SQLDA for both the base and extended SQLVARs, information for the LOBs and distinct types is returned. The 7th byte of SQLDAID is set to the number of SQLVAR entries that were used for each column:

2

Two SQLVAR entries per column (a base and an extended)

3

Three SQLVAR entries per column (a base and two extended)

SQLD is set to the number of columns in the result. Therefore, the value of the 7th byte of SQLDAID multiplied by the value of SQLD is the total number SQLVAR entries that were provided.

Otherwise, when an insufficient number of SQLVAR entries have been provided when LOBs or distinct types are present, Db2 indicates that by returning one of the following warnings in SQLCODE. Db2 also sets the 7th byte of SQLDAID to indicate how many SQLVAR entries are needed for each column of the result.

+237

There are insufficient SQLVAR entries to describe the data, and the data includes distinct types. In this case, there were enough base SQLVAR entries to describe the data, so the base SQLVAR entries are set. However, sufficient extended SQLVAR entries were not provided so the distinct type names are not returned.

+238

There are insufficient SQLVAR entries to describe the data, and the data includes LOBs. In this case no information is returned in the SQLVAR entries.

+239

There are insufficient SQLVAR entries to describe the data, and the data includes distinct types. There weren't even enough base SQLVAR entries. In this case no information is returned in the SQLVAR entries.

Field descriptions of an occurrence of a base SQLVAR

The fields of a base SQLVAR have different uses depending on the SQL statement.

The following table describes the contents of the fields of a base SQLVAR.

Table 256. Fields in an occurrence of a base SQLVAR

C name assembler COBOL, or PL/I name	Data type	Usage in DESCRIBE¹ and PREPARE INTO	Usage in FETCH, OPEN, EXECUTE, and CALL
sqltype SQLTYPE	SMALLINT	Indicates the data type of the column or parameter and whether it can contain null values. For a description of the type codes, see Table 258 on page 2323 . For a distinct type, the data type on which the distinct type was based is placed in this field. The base SQLVAR provides no indication that this is part of the description of a distinct type.	Indicates the data type of the host variable and whether an indicator variable is provided. Host variables for datetime values must be character string variables. For FETCH, a datetime type code means a fixed-length character string. For a description of the type codes, see “SQLTYPE and SQLLEN” on page 2322 .

Table 256. Fields in an occurrence of a base SQLVAR (continued)

C name assembler COBOL, or PL/I name	Data type	Usage in DESCRIBE ¹ and PREPARE INTO	Usage in FETCH, OPEN, EXECUTE, and CALL
sqllen SQLLEN	SMALLINT	<p>The length attribute of the column or parameter. For datetime data, the length of the string representation of the value. See “SQLTYPE and SQLLEN” on page 2322 for a description of allowable values.</p> <p>For LOBs, the value is 0 regardless of the length attribute of the LOB. For XML, the value is 0. Field SQLLONGLEN in the extended SQLVAR contains the length attribute.</p>	<p>The length attribute of the host variable. See “SQLTYPE and SQLLEN” on page 2322 for a description of allowable values.</p> <p>For LOBs, the value is 0 regardless of the length attribute of the LOB. Field SQLLONGLEN in the extended SQLVAR contains the length attribute.</p> <p>For XML AS BLOB, CLOB, or DBCLOB, sqllen is 0 as for LOB types.</p>
sqldata SQLDATA	Pointer	<p>For string columns or parameters, SQLDATA contains X'0000zzzz', where zzzz is the associated CCSID. For character strings, SQLDATA can alternatively contain X'FFFF', which indicates bit data. Not used for other types of data.</p> <p>For datetime columns, SQLDATA can contain the CCSID of the string representation of the datetime value.</p> <p>For DESCRIBE PROCEDURE, the result set locator value associated with the result set.</p>	Contains the address of the host variable.
sqlind SQLIND	Pointer	<p>Reserved</p> <p>For DESCRIBE PROCEDURE, it is set to -1.</p>	Contains the address of an associated indicator variable, if SQLTYPE is odd. Otherwise, the field is not used.

Table 256. Fields in an occurrence of a base SQLVAR (continued)

C name assembler COBOL, or PL/I name	Data type	Usage in DESCRIBE ¹ and PREPARE INTO	Usage in FETCH, OPEN, EXECUTE, and CALL
sqlname SQLNAME	VARCHAR(30)	<p>Contains the unqualified name or label of the column, or a string of length zero if the name or label does not exist. If the name is longer than 30 bytes, it is truncated at a byte boundary. For more information about column names, see Names of result columns.</p> <p>For DESCRIBE PROCEDURE, SQLNAME contains the cursor name used by the stored procedure to return the result set. The values for SQLNAME appear in the order the cursors were opened by the stored procedure.</p> <p>For DESCRIBE INPUT, SQLNAME is not used.</p>	<p>Can contain CCSID and/or host-variable-array dimension information. Db2 interprets the third and fourth byte of the data portion of SQLNAME as the CCSID of the host variable if all of the following are true and the third and fourth byte are not X'0000':</p> <ul style="list-style-type: none"> • The sixth byte of SQLDAID is '+' (x'4E'). • SQLTYPE indicates the host variable is a string variable. • The length of SQLNAME is 8. • The first two bytes of the data portion of SQLNAME are X'0000'. <p>If the third and fourth byte of the data portion of SQLNAME are X'0000', Db2 uses the appropriate default CCSID.</p> <p>For FETCH, OPEN, INSERT, and EXECUTE, if the length of SQLNAME is 8, and the first two bytes of the data portion of SQLNAME are X'0000', Db2 interprets the fifth through eighth bytes of the data portion of the SQLNAME field as follows:</p>

Table 256. Fields in an occurrence of a base SQLVAR (continued)

C name assembler COBOL, or PL/I name	Data type	Usage in DESCRIBE ¹ and PREPARE INTO	Usage in FETCH, OPEN, EXECUTE, and CALL
(cont.) sqlname SQLNAME			<ul style="list-style-type: none"> • Fifth and sixth bytes: A flag field that indicates the type of host variable that is being described by the current SQLDA entry. The values of this field are as follows: <ul style="list-style-type: none"> – X'0000' - host variable – X'0100' - XML host variable (XML AS BLOB, XML AS CLOB, XML AS DBCLOB) – X'0001' - host-variable array – X'0101' - XML host-variable array – X'0002' - special host variable that represents the value for 'n' in a multiple-row INSERT statement • Seventh and eighth bytes: If the sixth byte is X'01', a binary small integer (halfword) that represents the dimension of the host-variable-array, and the corresponding indicator-array if one is specified.

Notes:

1. The third column of this table represents several forms of the DESCRIBE statement.
 - For DESCRIBE *output* and PREPARE INTO, the column pertains to columns of the result table.
 - For DESCRIBE CURSOR, the column pertains to a result set associated with a cursor.
 - For DESCRIBE INPUT, the column pertains to parameter markers.
 - For DESCRIBE PROCEDURE, the column pertains to the result sets returned by the stored procedure.

Field descriptions of an occurrence of an extended SQLVAR

The fields of an extended SQLVAR have different uses depending on the SQL statement.

The following table describes the contents of the fields of an extended SQLVAR entry.

Table 257. Fields in an occurrence of an extended SQLVAR

C name assembler, COBOL, or PL/I name	Data type	Usage in DESCRIBE ¹ and PREPARE INTO	Usage in FETCH, OPEN, EXECUTE, and CALL
len.sqllonglen SQLLONGL SQLLONGLEN	INTEGER	The length attribute of a LOB (BLOB, CLOB, or DBCLOB) column	The length attribute of a LOB (BLOB, CLOB, or DBCLOB) host variable. Db2 ignores the SQLLEN field in the base SQLVAR for these data types. The length attribute indicates the number of bytes for a BLOB or CLOB, and the number of characters for a DBCLOB.
*	INTEGER	Reserved	Reserved.
sqldataalen SQLDATA SQLDATALEN	Pointer	Not used	<p>Used only for LOB (BLOB, CLOB, and DBCLOB) host variables.</p> <p>If the value of the field is null, the actual length of the LOB is stored in the 4 bytes immediately before the start of the data, and SQLDATA points to the first byte of the field length. The actual length indicates the number of bytes for a BLOB or CLOB, and the number of characters for a DBCLOB.</p> <p>If the value of the field is not null, the field contains a pointer to a 4-byte long buffer that contains the actual length <i>in bytes</i> (even for DBCLOBs) of the data in the buffer pointed to from the SQLDATA field in the matching base SQLVAR.</p> <p>Regardless of whether this field is used, field SQLLONGLEN must be set.</p>

Table 257. Fields in an occurrence of an extended SQLVAR (continued)

C name assembler, COBOL, or PL/I name	Data type	Usage in DESCRIBE ¹ and PREPARE INTO	Usage in FETCH, OPEN, EXECUTE, and CALL
sqldatatype_name e SQLNAME SQLDATATYPE- NAME	VARCHAR(30)	<p>A SQLTNAME field of the extended SQLVAR is set to one of the following:</p> <ul style="list-style-type: none"> • For a distinct type column, the database manager sets this field to the fully qualified distinct type name. If the qualified name is longer than 30 bytes, it is truncated. • For a label, the database manager sets this field to label. <p>In the case that both a distinct type name and a label need to be returned in extended SQLVAR entries (USING BOTH has been specified), the distinct type name is returned in the first extended SQLVAR entry and the label in the second extended SQLVAR entry.</p>	Not used.

Note:

1. The third column of this table represents several forms of the DESCRIBE statement.
 - For DESCRIBE *output* and PREPARE INTO, the column pertains to columns of the result table.
 - For DESCRIBE CURSOR, the column pertains to a result set associated with a cursor.
 - For DESCRIBE INPUT, the column pertains to parameter markers.
 - For DESCRIBE PROCEDURE, the column pertains to the result sets returned by the stored procedure.

SQLTYPE and SQLLEN

The contents of the SQLTYPE and SQLLEN fields of the SQLDA depends on the SQL statement that is returning the value.

The following table shows the values that can appear in the SQLTYPE and SQLLEN fields of the SQLDA. In DESCRIBE and PREPARE INTO, an even value of SQLTYPE means the column does not allow nulls, and an odd value means the column does allow nulls. In DESCRIBE INPUT statements, only odd values are returned for SQLTYPE. In FETCH, OPEN, EXECUTE, and CALL, an even value of SQLTYPE means no indicator variable is provided, and an odd value means that SQLIND contains the address of an indicator variable.

Table 258. *SQLTYPE* and *SQLLEN* values for *DESCRIBE*, *PREPARE INTO*, *FETCH*, *OPEN*, *EXECUTE*, and *CALL*

SQLTYPE	For DESCRIBE and PREPARE INTO		For FETCH, OPEN, EXECUTE, and CALL	
	Column or parameter data type	SQLLEN	Host variable data type	SQLLEN
384/385	Date	10 ¹	Fixed-length character string representation of a date	Length attribute of the host variable
388/389	Time	8 ²	Fixed-length character string representation of a time	Length attribute of the host variable
392/393	Timestamp without time zone	19 for <i>TIMESTAMP(0)</i> otherwise $20+p$ for <i>TIMESTAMP(p)</i> ⁵	fixed-length Character string representation of a timestamp	Length attribute of the host variable
400/401	N/A	N/A	NUL-terminated graphic string	Length attribute of the host variable
404/405	BLOB	0 ³	BLOB or XML AS BLOB	Not used. ³
408/409	CLOB	0 ³	CLOB or XML AS CLOB	Not used. ³
412/413	DBCLOB	0 ³	DBCLOB or XML AS DBCLOB	Not used. ³
448/449	Varying-length character string	Length attribute of the column	Varying-length character string	Length attribute of the host variable
452/453	Fixed-length character string	Length attribute of the column	Fixed-length character string	Length attribute of the host variable
456/457	Long varying-length character string SQLTYPE values 448/449 are returned instead of 456/457 for statements that are bound in Version 9 or later.	Length attribute of the column	Long varying-length character string	Length attribute of the host variable
460/461	N/A	N/A	NUL-terminated character string	Length attribute of the host variable
464/465	Varying-length graphic string	Length attribute of the column	Varying-length graphic string	Length attribute of the host variable
468/469	Fixed-length graphic string	Length attribute of the column	Fixed-length graphic string	Length attribute of the host variable
472/473	Long graphic string SQLTYPE values 464/465 are returned instead of 472/473 for statements that are bound in Version 9 or later.	Length attribute of the column	Long graphic string	Length attribute of the host variable

Table 258. *SQLTYPE* and *SQLLEN* values for *DESCRIBE*, *PREPARE INTO*, *FETCH*, *OPEN*, *EXECUTE*, and *CALL* (continued)

SQLTYPE	For DESCRIBE and PREPARE INTO		For FETCH, OPEN, EXECUTE, and CALL	
	Column or parameter data type	SQLLEN	Host variable data type	SQLLEN
480/481	Floating point	4 for single precision, 8 for double precision	Floating point	4 for single precision, 8 for double precision
484/485	Packed decimal	Precision in byte 1; scale in byte 2	Packed decimal	Precision in byte 1; scale in byte 2
492/493	Big integer ⁴	8	Big integer	8
496/497	Large integer	4	Large integer	4
500/501	Small integer	2	Small integer	2
504/505	N/A	N/A	DISPLAY SIGN LEADING SEPARATE, NATIONAL SIGN LEADING SEPARATE	Precision in byte 1; scale in byte 2
904/905	ROWID	40	ROWID	40
908/909	Varying-length binary string	Length attribute of the column	Varying-length binary string	Length attribute of the host variable
912/913	Fixed-length binary string	Length attribute of the column	Fixed-length binary string	Length attribute of the host variable
916/917	BLOB_FILE	267		
920/921	CLOB_FILE	267		
924/925	DBCLOB_FILE	267		
960/961	BLOB locator	4	BLOB_LOCATOR	4
964/965	CLOB locator	4	CLOB_LOCATOR	4
968/969	DBCLOB locator	4	DBCLOB_LOCATOR	4
972	Not applicable	Not applicable	Result set locator	4
988/989	XML	0	Invalid. Instead, use one of the following: XML AS BLOB, XML AS CLOB, XML AS DBCLOB	Not used
996/997	DECFLOAT(16) DECFLOAT(34)	8 16	DECFLOAT(16) DECFLOAT(34)	8 16
2448/2449	Timestamp with time zone	147 for TIMESTAMP(0) WITH TIME ZONE otherwise 148+p for TIMESTAMP(p) WITH TIME ZONE ⁵	Varying-length character string representation of a timestamp with time zone	Length attribute of the host variable

Table 258. *SQLTYPE* and *SQLLEN* values for *DESCRIBE*, *PREPARE INTO*, *FETCH*, *OPEN*, *EXECUTE*, and *CALL* (continued)

SQLTYPE	For DESCRIBE and PREPARE INTO		For FETCH, OPEN, EXECUTE, and CALL	
	Column or parameter data type	SQLLEN	Host variable data type	SQLLEN

Note:

1. *SQLLEN* might be different if a date installation exit is specified.
2. *SQLLEN* might be different if a time installation exit is specified.
3. Field *SQLLONGLEN* in the extended *SQLVAR* contains the length attribute of the column. In *REXX*, the *SQLVAR* length attribute field name is *SQLLONGL* and *SQLLEN* is not used.
4. *BIGINT* is supported by other Db2 platforms.
5. *p* is the timestamp precision.

SQLDATA

Depending on the data type of the string column that the *SQLVAR* is describing, the *SQLDATA* field can contain different *CCSID* values.

The following table identifies the *CCSID* values that appear in the *SQLDATA* field when the *SQLVAR* element describes a string column.

Table 259. *CCSID* values for *SQLDATA*

Data type	Subtype	Bytes 1 and 2	Bytes 3 and 4
Character	SBCS data	X'0000'	CCSID
Character	Mixed data	X'0000'	CCSID
Character	BIT data	X'0000'	X'FFFF'
Graphic	N/A	X'0000'	CCSID
Any other data type	N/A	N/A	N/A

Unrecognized and unsupported SQLTYPES

The values that appear in the *SQLTYPE* field of the *SQLDA* are dependent on the level of data type support available at the sender as well as at the receiver of the data. This support is particularly important as new data types are added to the product.

New data types might not be supported by the sender or receiver of the data and might not be recognized by the sender or receiver of the data. Depending on the situation, the new data type might be returned, a compatible data type that is agreed to by both the sender and the receiver of the data might be returned, or an error might occur.

When the sender and receiver agree to use a compatible data type, the following table indicates the mapping that takes place. This mapping takes place when at least one of the sender or receiver does not support the data type provided. The unsupported data type can be provided by either the application or the database manager.

Table 260. *Compatible data types for unsupported data types*

Data type	Compatible data type
ROWID	VARCHAR(40) FOR BIT DATA

No indication is given in the *SQLDA* that the data type is substituted.

The included SQLDA

Only assembler, C, C++, COBOL, and PL/I C are supported for the SQLDA that is given by INCLUDE SQLDA.

assembler:

```
SQLTRIPL EQU    C'3'  
SQLDOUBL EQU    C'2'  
SQLSINGL EQU    C' '  
*  
        SQLSECT SAVE  
*  
SQLDA   DSECT  
SQLDAID DS      CL8      ID  
SQLDABC DS      F        BYTE COUNT  
SQLN    DS      H        COUNT SQLVAR/SQLVAR2 ENTRIES  
SQLD    DS      H        COUNT VARS (TWICE IF USING BOTH)  
*  
SQLVAR  DS      0F       BEGIN VARS  
SQLVARN DSECT  ,        NTH VARIABLE  
SQLTYPE DS      H        DATA TYPE CODE  
SQLLEN  DS      0H       LENGTH  
SQLPRCSN DS     X        DEC PRECISION  
SQLSCALE DS     X        DEC SCALE  
SQLDATA DS      A        ADDR OF VAR  
SQLIND  DS      A        ADDR OF IND  
SQLNAME DS      H,CL30   DESCRIBE NAME  
SQLVSIZ EQU    *-SQLDATA  
SQLSIZV EQU    *-SQLVARN  
*  
SQLDA   DSECT  
SQLVAR2 DS      0F       BEGIN EXTENDED FIELDS OF VARS  
SQLVAR2N DSECT ,        EXTENDED FIELDS OF NTH VARIABLE  
SQLLONGL DS     F        LENGTH  
SQLRSVDL DS     F        RESERVED  
SQLDATAL DS     A        ADDR OF LENGTH IN BYTES  
SQLTNAME DS     H,CL30   DESCRIBE NAME  
*  
        SQLSECT RESTORE
```

In the above declaration, SQLSECT SAVE is a macro invocation that remembers the current CSECT name. SQLSECT RESTORE is a macro invocation that continues that CSECT.

C and C++:

```
#ifndef SQLDASIZE /* Permit duplicate Includes */  
/**/  
struct sqlvar  
{ short sqltype;  
  short sqllen;  
  char *sqldata;  
  short *sqlind;  
  struct sqlname  
  { short length;  
    char data[30];  
  } sqlname;  
};  
/**/  
struct sqlvar2  
{ struct  
  { long sqllonglen;  
    unsigned long reserved;  
  } len;  
  char *sqldatalen;  
  struct sqldistinct_type  
  { short length;  
    char data[30];  
  } sqldatatype_name;  
};  
/**/  
struct sqlda  
{ char sqldaaid[8];  
  long sqldabc;  
  short sqln;  
  short sqld;  
  struct sqlvar sqlvar[1];
```



```

/* pointer field returns a pointer to a long (4 byte) integer. */
/* If the SQLDATALEN pointer is zero, a NULL pointer is be returned. */
/*
/* NOTE: Use this only if the sqlda has been doubled or tripled. */
/*****
#define GETSQLDALENPTR(daptr,n) ( \
    ((struct sqlvar2 *) &(daptr);->sqlvar[(n) + (daptr)->sqld] \
    ->sqldataalen == NULL) ? \
    ((long *) NULL) : \
    ((long *) ((struct sqlvar2 *) \
    &(daptr);->sqlvar[(n) + (daptr)->sqld] \
    ->sqldataalen) ) )
/****/
/*****
/* SETSQLDALENPTR(daptr,n,ptr) sets a pointer to the data length for */
/* the nth entry in the sqlda pointed to by daptr. */
/* Use this only if the sqlda has been doubled or tripled. */
/*****
#define SETSQLDALENPTR(daptr,n,ptr) { \
    struct sqlvar2 *var2ptr; \
    var2ptr = (struct sqlvar2 *) \
    &((daptr);->sqlvar[(n) + ((daptr)->sqld)]); \
    var2ptr->sqldataalen = (char *) ptr; \
}
/****/
#define SQLDASIZE(n) \
    ( sizeof(struct sqlda) + ((n)-1) * sizeof(struct sqlvar) )
#endif /* SQLDASIZE */

```

COBOL (IBM COBOL only):

```

01 SQLDA.
  05 SQLDAID PIC X(8).
  05 SQLDABC PIC S9(9) BINARY.
  05 SQLN PIC S9(4) BINARY.
  05 SQLD PIC S9(4) BINARY.
  05 SQLVAR OCCURS 0 TO 750 TIMES DEPENDING ON SQLN.
    10 SQLVAR1.
      15 SQLTYPE PIC S9(4) BINARY.
      15 SQLLEN PIC S9(4) BINARY.
      15 FILLER REDEFINES SQLLEN.
        20 SQLPRECISION PIC X.
        20 SQLSCALE PIC X.
      15 SQLDATA POINTER.
      15 SQLIND POINTER.
      15 SQLNAME.
        49 SQLNAME1 PIC S9(4) BINARY.
        49 SQLNAMEC PIC X(30).
    10 SQLVAR2 REDEFINES SQLVAR1.
      15 SQLVAR2-RESERVED-1 PIC S9(9) BINARY.
      15 SQLLONGLEN REDEFINES SQLVAR2-RESERVED-1
        PIC S9(9) BINARY.
      15 SQLVAR2-RESERVED-2 PIC S9(9) BINARY.
      15 SQLDATALEN POINTER.
      15 SQLDATATYPE-NAME.
        20 SQLDATATYPE-NAME1 PIC S9(4) BINARY.
        20 SQLDATATYPE-NAMEC PIC X(30).

```

PL/I:

```

DECLARE
  1 SQLDA BASED(SQLDAPTR),
  2 SQLDAID CHAR(8),
  2 SQLDABC FIXED(31) BINARY,
  2 SQLN FIXED(15) BINARY,
  2 SQLD FIXED(15) BINARY,
  2 SQLVAR(SQLSIZE REFER(SQLN)),
  3 SQLTYPE FIXED(15) BINARY,
  3 SQLLEN FIXED(15) BINARY,
  3 SQLDATA POINTER,
  3 SQLIND POINTER,
  3 SQLNAME CHAR(30) VAR;
/* */
DECLARE
  1 SQLDA2 BASED(SQLDAPTR),
  2 SQLDAID2 CHAR(8),
  2 SQLDABC2 FIXED(31) BINARY,

```

```

2 SQLN2     FIXED(15) BINARY,
2 SQLD2     FIXED(15) BINARY,
2 SQLVAR2(SQLSIZE REFER(SQLN2)),
3  SQLBIGLEN,
4  SQLLONGL FIXED(31) BINARY,
4  SQLRSVDL FIXED(31) BINARY,
3  SQLDATAL POINTER,
3  SQLTNAME CHAR(30) VAR;
/* */
DECLARE SQLSIZE     FIXED(15) BINARY;
DECLARE SQLDAPTR   POINTER;
DECLARE SQLTRIPLED CHAR(1)   INITIAL('3');
DECLARE SQLDOUBLED CHAR(1)   INITIAL('2');
DECLARE SQLSINGLED CHAR(1)   INITIAL(' ');

```

Identifying an SQLDA in C or C++

A *descriptor-name* can be specified in the CALL, DESCRIBE, EXECUTE, FETCH, and OPEN statements. When the host application is written in C or C++, *descriptor-name* can be a pointer variable with pointer notation.

For example, *descriptor-name* could be declared as

```
sqlda *outsqlda;
```

Afterwards, it could be used in a statement like the following:

```
EXEC SQL DESCRIBE STMT1 INTO DESCRIPTOR :*outsqlda;
```

The REXX SQLDA

A REXX SQLDA consists of a set of REXX variables with a common stem. The stem must be a REXX variable name that contains no periods and is the same as the value of *descriptor-name* that you specify when you use the SQLDA in an SQL statement. Db2 does not support the INCLUDE SQLDA statement in REXX.

The following table shows the variable names in a REXX SQLDA. The values in the second column of the table are values that Db2 inserts into the SQLDA when the statement executes. Except where noted otherwise, the values in the third column of the table are values that the application must put in the SQLDA before the statement executes.

Table 261. Fields of a REXX SQLDA

Variable name	Usage in DESCRIBE and PREPARE INTO	Usage in FETCH, OPEN, EXECUTE, and CALL
<i>stem</i> .SQLD	The number of columns that are described in the SQLDA. Double that number if USING BOTH appears in the DESCRIBE or PREPARE INTO statement. Contains a 0 if the statement string is not a query. For DESCRIBE PROCEDURE, the number of result sets returned by the stored procedure. Contains a 0 if no result sets are returned.	The number of host variables that are used by the SQL statement.

Each SQLDA contains *stem*.SQLD of the following variables. Therefore, $1 \leq n \leq \text{stem}.SQLD$. There is one occurrence of each variable for each column of the result table or host variable that is described by the SQLDA.

Table 261. Fields of a REXX SQLDA (continued)

Variable name	Usage in DESCRIBE and PREPARE INTO	Usage in FETCH, OPEN, EXECUTE, and CALL
<i>stem.n</i> .SQLTYPE	<p>Indicates the data type of the column or parameter and whether it can contain null values. For a description of the type codes, see “SQLTYPE and SQLLEN” on page 2322.</p> <p>For a distinct type, the data type on which the distinct type was based is placed in this field. The base SQLVAR provides no indication that this is part of the description of a distinct type.</p>	<p>Indicates the data type of the host variable and whether an indicator variable is provided. Host variables for datetime values must be character string variables. For FETCH, a datetime type code means a fixed-length character string. For a description of the type codes, see “SQLTYPE and SQLLEN” on page 2322.</p> <p>The data type of the host variable cannot be BLOB locator, CLOB locator, or DBCLOB locator.</p>
<i>stem.n</i> .SQLLONGL	<p>For a LOB column, the length of the string representation of the value or parameter.</p>	<p>For a host variable that has a LOB data type, the length attribute of the host variable. For a description of supported values, see “SQLTYPE and SQLLEN” on page 2322.</p>
<i>stem.n</i> .SQLLEN	<p>For a column other than a DECIMAL, NUMERIC, or LOB column, the length attribute of the column or parameter. For datetime data, the length of the string representation of the value. See “SQLTYPE and SQLLEN” on page 2322 for a description of allowable values.</p>	<p>For a host variable that does not have a decimal or LOB data type, the length attribute of the host variable. See “SQLTYPE and SQLLEN” on page 2322 for a description of allowable values.</p>
<i>stem.n</i> .SQLLEN.SQLPRECISION	<p>For a DECIMAL or NUMERIC column, the precision of the column or parameter.</p>	<p>For a host variable with a decimal data type, the precision of the host variable.</p>
<i>stem.n</i> .SQLLEN.SQLSCALE	<p>For a DECIMAL or NUMERIC column, the scale of the column or parameter.</p>	<p>For a host variable with a decimal data type, the scale of the host variable.</p>
<i>stem.n</i> .SQLCCSID	<p>For a string column or parameter, the CCSID of the column or parameter.</p>	<p>For a string host variable, the CCSID of the host variable.</p>
<i>stem.n</i> .SQLUSECCSID	<p>Not used.</p>	<p>Set to a new CCSID. If set, REXX will change the CCSID of the SQLDATA.</p>
<i>stem.n</i> .SQLLOCATOR	<p>For DESCRIBE PROCEDURE, the value of a result set locator.</p>	<p>Not used.</p>

Table 261. Fields of a REXX SQLDA (continued)

Variable name	Usage in DESCRIBE and PREPARE INTO	Usage in FETCH, OPEN, EXECUTE, and CALL
<i>stem.n</i> .SQLDATA	Not used.	<p>Before EXECUTE or OPEN, contains the value of an input host variable. The application must supply this value.</p> <p>After FETCH, contains the values of an output host variable.</p>
<i>stem.n</i> .SQLIND	Not used.	<p>Before EXECUTE or OPEN, contains a negative number to indicate that the input host variable in <i>stem.n</i>.SQLDATA is null. The application must supply this value.</p> <p>After FETCH, contains a negative number if the value of the output host variable in <i>stem.n</i>.SQLDATA is null.</p>
<i>stem.n</i> .SQLNAME	<p>The name of the <i>n</i>th column in the result table. For DESCRIBE PROCEDURE, contains the cursor name that is used by the stored procedure to return the result set. The values for SQLNAME appear in the order that the cursors were opened by the stored procedure.</p>	Not used.
<i>stem.n</i> .SQLTNAME	<p>The fully qualified distinct type name of the <i>n</i>th column in the result table. If the qualified name is longer than 30 bytes, it is truncated.</p>	Not used.

Appendix H. Db2 catalog tables

Db2 for z/OS maintains a set of tables (in database DSNDB06) called the Db2 catalog.

About these topics

These topics describe that catalog by describing the columns of each catalog table.

The catalog tables describe such things as table spaces, tables, columns, indexes, privileges, application plans, and packages. Authorized users can query the catalog; however, it is primarily intended for use by Db2 and is therefore subject to change. All catalog tables are qualified by SYSIBM. Do not use this qualifier for user-defined tables.

The catalog tables are updated by Db2 during normal operations in response to certain SQL statements, commands, and utilities.

Db2 12 catalog levels

The *catalog level* of a data sharing group or subsystem indicates that a particular CATMAINT utility UPDATE LEVEL job was run on the Db2 catalog, and the data sharing group or Db2 subsystem is ready for the activation of certain function levels.

Db2 12 function levels use the following Db2 catalog levels:

- V12R1M509
- V12R1M507
- V12R1M505
- V12R1M503
- V12R1M502
- V12R1M500

Tip: When you update the Db2 catalog level, you can specify either the target function level or the catalog level. If you specify the function level, Db2 determines the appropriate target catalog level, and the CATMAINT utility completes any required catalog level updates in sequential order. For more information, see [CATMAINT \(Db2 Utilities\)](#).

For a summary of the changes, see [Catalog changes in Db2 12 \(Db2 for z/OS What's New?\)](#).

Trailing blanks in converted catalog columns

Db2 subsystems that were migrated from earlier releases might have trailing blanks in catalog table columns that were converted from fixed to varying length data types. You might need to make adjustments in applications that use these columns in comparisons. For more information, see [Trailing blanks in Db2 catalog columns \(Db2 Administration Guide\)](#).

Release indicators in the Db2 catalog

Some objects depend on functions in particular releases of Db2. If you are running on a release of Db2 and fall back to a previous release, an object that depends on the more recent release becomes frozen. The object is marked with a release dependency indicator and is unavailable until remigration.

The release dependency indicator, which is listed in the IBMREQD, RELCREATED, and RELBOUND columns of the catalog tables, shows the release of Db2 upon which the objects depend.

Important: The IBMREQD column is not a reliable indicator for indicating release dependencies. Where possible, the RELCREATED and RELBOUND columns should be used instead.

Db2 release dependency indicators in the IBMREQD, RELCREATED, and RELBOUND columns might use the following values:

Values	Meanings for IBMREQD, RELCREATED, and RELBOUND columns
R	Db2 13
Q	Db2 12
P	Db2 11
O	DB2 10
M	DB2 9
L	DB2 version 8
K	DB2 version 7
J	DB2 version 6
I	DB2 version 6
H	DB2 version 5
G	DB2 version 4
F	DB2 version 3R1
E	DB2 version 2R3
D	DB2 version 2R2
C	DB2 version 2R1
B	DB2 version 1R3
Y	Rows with IBMREQD='Y' were provided with the Db2 for z/OS product code
N	Rows with IBMREQD='N' have no release dependency and were not provided with the Db2 for z/OS product code

Programming interface information

Not all catalog table columns are part of the general-use programming interface. Whether a column is part of this interface is indicated in a column labeled "Use" in the table that describes the column. The meanings of the Use column values are shown in the following table.

Use column value	Meaning
G	Column is part of the general-use programming interface
S	Column is part of the product-sensitive interface
I	Column is for internal use only
N	Column is not used

For columns with N or I in the Use column, the name of the column and its description might not appear in the explanation of the column.

For more information about programming interface information, see [Programming interface information \(Introduction to Db2 for z/OS\)](#).

Table 262. Db2 catalog tables. The qualifier for all catalog table names is SYSIBM.

Table	Table space	Indexes (Type "2" on page 2347)	Description
<u>IPLIST</u>	SYSDDF	DSNDUX01 (U)	Contains a row for each IP address that corresponds to a remote DRDA server
<u>IPNAMES</u>	SYSDDF	DSNFPX01 (UC)	Contains a row for each remote DRDA server that Db2 can access using TCP/IP
<u>LOCATIONS</u>	SYSDDF	DSNFCX01 (UC)	Contains a row for every accessible remote server
<u>LULIST</u>	SYSDDF	DSNFLX01 DSNFLX02	Contains a row for each real LU name that is associated with the dummy LU name for a data sharing group
<u>LUMODES</u>	SYSDDF	DSNFMX01 (UC)	Contains a row for the conversation limit for each combination of LU name and VTAM logon mode description
<u>LUNAMES</u>	SYSDDF	DSNFX01 (UC)	Contains a row for each remote SNA client or server
<u>MODESELECT</u>	SYSDDF	DSNFDX01 (UC)	Contains a row for each VTAM logon mode and combination of authorization ID, plan name, and LU name
<u>SYSAUDITPOLICIES</u>	SYSTSADT	DSNAPX03 (UC)	Each row represents an audit policy.
<u>SYSAUDITPOLICIES_H</u>	SYSTSADH	—	Not used
<u>SYSAUTOALERTS</u>	SYSTSATS	DSNALX01 (UC) DSNALX02 (N) DSNALX03 (N) DSNALX04 (N) DSNALX05 (N) DSNALX06 (N)	Contains a row for each recommendation from the autonomic procedures
<u>SYSAUTOALERTS_OUT</u>	SYSTSATX	DSNALX07 (A)	Contains the LOB data for the OUTPUT column of SYSIBM.SYSAUTOALERTS
<u>SYSAUTORUNS_HIST</u>	SYTSPRH	DSNPHX01 (UC) DSNPHX02 (N) DSNPHX03 (N)	Contains a row for each execution of an autonomic procedure.
<u>SYSAUTORUNS_HISTOU</u>	SYTSPHX	DSNPHX04 (A)	Contains the LOB data for the OUTPUT column of SYSIBM.SYSAUTORUNS_HIST
<u>SYSAUTOTIMEWINDOWS</u>	SYTSATW	DSNTWX01 (UC)	Contains a row for each time period during which autonomic procedures can be run

Table 262. Db2 catalog tables. The qualifier for all catalog table names is SYSIBM. (continued)

Table	Table space	Indexes (Type "2" on page 2347)	Description
SYSAUXRELS	SYSTSAUX	DSNOXX01 (NC) DSNOXX02 (N)	Contains one row for each auxiliary table for a LOB column
SYSCHECKDEP	SYSTSCKD	DSNSDX01 (UC)	Contains one row for each reference to a column in a table check constraint
SYSCHECKS2	SYSTSCHX	DSNCHX01 (UC)	Contains one row for each table check constraint
SYSCHECKS	SYSTSCKS	DSNSCX01 (UC)	Contains one row for each table check constraint
SYSCOLAUTH	SYSTSFAU	DSNACX01 (N) DSNACX02 (N) DSNACX03 (N) DSNACX04 (N)	Records the UPDATE privileges that are held by users on individual columns of a table or view
SYSCOLAUTH_H	SYSTSFAH	—	Not used
SYSCOLDIST	SYSSTATS	DSNTNX01 (NC)	Contains cardinality, frequency, and histogram statistics for a single column or a column group.
SYSCOLDIST_HIST	SYSHIST	DSNHFX01 (N)	Contains accumulated rows from SYSCOLDIST
SYSCOLDISTSTATS	SYSSTATS	DSNTPX01 (NC)	Contains cardinality, frequency, and histogram statistics for a single column or a column group. Each partition can have 0 or more rows.
SYSCOLSTATS	SYSSTATS	DSNTCX01 (NC)	Contains partition statistics for selected columns. Each column contains a row for each partition in the table
SYSCOLUMNS	SYTSCOL	DSNDCX01 (U) DSNDCX02 (N) DSNDCX05 (N) DSNDCX06 (N)	Contains one row for every column of each table and view
SYSCOLUMNS_HIST	SYSHIST	DSNHEX01 (N)	Contains accumulated rows from SYSCOLUMNS
SYSCONSTDEP	SYTSCON	DSNCCX01 (N) DSNCCX02 (N)	Records dependencies on check constraints or user-defined defaults for a column
SYSCONTEXTAUTHIDS	SYSCTX	DSNCDX01 (UC) DSNCDX02 (N)	Contains the authorization ID under which a trusted context can be used.
SYSCONTEXTAUTHID_H	SYTSCXH	—	Not used

Table 262. Db2 catalog tables. The qualifier for all catalog table names is SYSIBM. (continued)

Table	Table space	Indexes (Type "2" on page 2347)	Description
<u>SYSCONTEXT</u>	SYSCONTX	DSNCTX01 (UC) DSNCTX02 (U) DSNCTX03 (U) DSNCTX04 (N)	Contains one row for each trusted context.
<u>SYSCONTEXT_H</u>	SYSTSCNH	—	Not used
<u>SYSCONTROLS</u>	SYSTSTCL	DSNCLX01 (U) DSNCLX02 (U) DSNCLX03 (N) DSNCLX04 (N) DSNCLX05 (N)	Contains one row for each row permission and column mask.
<u>SYSCONTROLS_DESC</u>	SYSTSTCD	DSNTRX02 (A)	Contains the LOB data for the DESCRIPTOR column of SYSIBM.SYSCONTROLS
<u>SYSCONTROLS_DESC_H</u>	SYSTSCHD	DSNTRX04 (A)	Contains the LOB data for the DESCRIPTOR column of SYSIBM.SYSCONTROLS_H
<u>SYSCONTROLS_RTXT</u>	SYSTSCTR	DSNTRX01 (A)	Contains the LOB data for the RULETEXT column of SYSIBM.SYSCONTROLS.
<u>SYSCONTROLS_RTXT_H</u>	SYSTSCHR	DSNTRX03 (A)	Contains the LOB data for the RULETEXT column of SYSIBM.SYSCONTROLS_H
<u>SYSCOPY</u>	SYTSCPY	DSNUCH01 (N) DSNUCX01 (N)	Contains information that is needed for recovery
<u>SYSCTXTTRUSTATTRS</u>	SYSCONTX	DSNCAX01 (UC)	Contains the attributes for a given trusted context
<u>SYSCTXTTRUSTATTR_H</u>	SYSTSTAH		Not used
<u>SYSDATABASE</u>	SYTSDBA	DSNDDH01 (U) DSNDDX02 (N)	Contains one row for each database, except for database DSNDDB01
<u>SYSDATATYPES</u>	SYTSDAT	DSNODX01 (U) DSNODX02 (U)	Contains one row for each distinct data type
<u>SYSDBAUTH</u>	SYTSDBU	DSNADH01 (N) DSNADX01 (N) DSNADH02 (N)	Records the privileges held by users over databases
<u>SYSDBAUTH_H</u>	SYTSDBH	—	Not used
<u>SYSDBRM</u>	SYTSDBR	DSNDBX01 (N) DSNDBX02 (U)	Contains one row for each DBRM of each application plan

Table 262. Db2 catalog tables. The qualifier for all catalog table names is SYSIBM. (continued)

Table	Table space	Indexes (Type "2" on page 2347)	Description
<u>SYSDEPENDENCIES</u>	SYSTSDEP	DSNONX01 (U) DSNONX02 (N)	Records the dependencies between objects
<u>SYSDUMMY1</u>	SYSEBCDC	—	Contains one row. This table is used by SQL statements that do not use any tables but must specify a table name.
<u>SYSDUMMYA</u>	SYSTSASC	—	Contains one row and is used for SQL statements in which a table reference is required, but the contents of the table are not important. SYSTSASC is an ASCII table space.
<u>SYSDUMMYE</u>	SYSEBCDC	—	Contains one row and is used for SQL statements in which a table reference is required, but the contents of the table are not important. SYSEBCDIC is an EBCDIC table space.
<u>SYSDUMMYU</u>	SYSTSUNI	—	Contains one row and is used for SQL statements in which a table reference is required, but the contents of the table are not important. SYSTSUNI is a UNICODE table space.
<u>SYSDYNQRY</u>	SYTSDQY	DSNDQX01 (U) DSNDQX02 (UC) DSNDQX11 (U)	Contains one row for each stabilized dynamic query.
<u>SYSDYNQRYDEP</u>	SYTSDQD	DSNDQX03 (N) DSNDQX04 (N) DSNDQX05 (N) DSNDQX12 (N)	Records the dependencies of stabilized dynamic queries.
<u>SYSDYNQRY_EXPL</u>	SYTSDQE	DSNDQX08 (A)	Internal use for stabilized dynamic queries.
<u>SYSDYNQRY_OPL</u>	SYTSDQO	DSNDQX10 (A)	Internal use for stabilized dynamic queries.
<u>SYSDYNQRY_SHTEL</u>	SYTSDQH	DSNDQX09 (A)	Internal use for stabilized dynamic queries.
<u>SYSDYNQRY_SPAL</u>	SYTSDQS	DSNDQX07 (A)	Internal use for stabilized dynamic queries.
<u>SYSDYNQRY_TXTL</u>	SYTSDQT	DSNDQX06 (A)	Internal use for stabilized dynamic queries.

Table 262. Db2 catalog tables. The qualifier for all catalog table names is SYSIBM. (continued)

Table	Table space	Indexes (Type "2" on page 2347)	Description
<u>SYSENVIRONMENT</u>	SYSTSENV	DSNOEX01 (U)	Records the environment variables when an object is created
<u>SYSFIELDS</u>	SYSTSFLD	DSNDFX01 (N)	Contains one row for every column that has a field procedure
<u>SYSFOREIGNKEYS</u>	SYSTSFOR	DSNDRH01 (N)	Contains one row for every column of every foreign key
<u>SYSINDEXCLEANUP</u>	SYSTSIXC	DSNICX01 (N)	Contains time window data to control index cleanup processing.
<u>SYSINDEXCONTROL</u>	SYSTSICO		Contains rows that specify time windows to control the use of memory allocated for an index.
<u>SYSINDEXES</u>	SYSTSIXS	DSNDXX01 (U) DSNDXX02 (U) DSNDXX03 (U) DSNDXX04 (N) DSNDXX07	Contains one row for every index
<u>SYSINDEXES_RTSECT</u>	SYSTSIXR	DSNDXX06 (A)	Contains the LOB data for the RTSECTION column of SYSIBM.SYSINDEXES.
<u>SYSINDEXES_TREE</u>	SYSTSIXT	DSNDXX05 (A)	Contains the LOB data for the PARSETREE column of SYSIBM.SYSINDEXES.
<u>SYSINDEXES_HIST</u>	SYSHIST	DSNHHX01 (NC) DSNHHX02 (N)	Contains accumulated rows from SYSINDEXES
<u>SYSINDEXPART</u>	SYSTSIPT	DSNDRX01 (U) DSNDRX02 (N) DSNDRX03 (N)	Contains one row for each nonpartitioned index and one row for each partition of a partitioning index or DPSI
<u>SYSINDEXPART_HIST</u>	SYSHIST	DSNHGX01 (N)	Contains accumulated rows from SYSINDEXPART
<u>SYSINDEXSPACESTATS</u>	SYSTSISS	DSNRTX02 (U) DSNRTX03 (N)	Contains Real-time Statistics for index spaces.
<u>SYSIXSPACESTATS_H</u>	SYSTSISH		A history table for temporal versioning of the " <u>SYSINDEXSPACESTATS catalog table</u> " on page 2482 table. For more information, see " <u>Temporal versioning for Db2 statistics-related catalog tables</u> " on page 2742.
<u>SYSINDEXSTATS</u>	SYSSTATS	DSNTXX01 (UC)	Contains one row for each partition of a partitioning index or data-partitioned secondary index (DPSI)

Table 262. Db2 catalog tables. The qualifier for all catalog table names is SYSIBM. (continued)

Table	Table space	Indexes (Type "2" on page 2347)	Description
<u>SYSINDEXSTATS_HIST</u>	SYSHIST	DSNHIX01 (NC)	Contains accumulated rows from SYSINDEXSTATS
<u>SYSJARCLASS_SOURCE</u>	SYSJAUXB	DSNJSX01 (A)	Contains the source code for a Java stored procedure
<u>SYSJARCONTENTS</u>	SYSJAVA	DSNJCX01 (NC)	Records the classes for each JAR file for a Java stored procedure
<u>SYSJARDATA</u>	SYSJAUXA	DSNJDX01 (A)	Contains the contents of the JAR file for each Java stored procedure
<u>SYSJAROBJECTS</u>	SYSJAVA	DSNJOX01 (UC)	Records the contents of each JAR file for a Java stored procedure
<u>SYSJAVAOPTS</u>	SYSJAVA	DSNJVX01 (UC)	Records the build options for a Java stored procedure
<u>SYSJAVAPATHS</u>	SYSJAVA	DSNJPX01 (U) DSNJPX02 (N)	Contains the complete JAR class resolution path, and records the dependencies that one JAR has on the JARs in its Java path.
<u>SYSKEYS</u>	SYSTSKEY	DSNDKX01 (U) DSNDKX02 (N) DSNDKX03 (U)	Contains one row for each column of an index key
<u>SYSKEYCOLUSE</u>	SYTSKYC	DSNCUX01 (N)	Contains a row for every column in a unique constraint (primary key or unique key)
<u>SYSKEYTARGETS</u>	SYSTARG	DSNRKX01 (UC) DSNRKX02 (N)	Contains one row for each key-target participating in an extended index definition
<u>SYSKEYTARGETS_HIST</u>	SYSHIST	DSNHKX01 (N)	Contains accumulated rows from SYSKEYTARGETS
<u>SYSKEYTARGETSTATS</u>	SYSSTATS	DSNTKX01 (U)	Contains partition statistics for selected key-targets
<u>SYSKEYTGTDIST</u>	SYSSTATS	DSNTDX01 (N)	Contains one or more rows for the first key-target of an extended index key
<u>SYSKEYTGTDIST_HIST</u>	SYSHIST	DSNTDX02 (N)	Contains accumulated rows from SYSKEYTGTDIST
<u>SYSKEYTGTDISTSTATS</u>	SYSSTATS	DSNTSX01 (N)	Contains zero or more rows per partition for the first key-target of a data-partitioned secondary index (DPSI)
<u>SYSLEVELUPDATES</u>	SYSTSLVH	DSNLVX01 (N) DSNLVX02 (N)	Contains information about the function levels, catalog levels, and code levels of the Db2 subsystem or data sharing group.

Table 262. Db2 catalog tables. The qualifier for all catalog table names is SYSIBM. (continued)

Table	Table space	Indexes (Type "2" on page 2347)	Description
<u>SYSLOBSTATS</u>	SYSSTATS	DSNLNK01 (UC)	Contains one row for each LOB table space
<u>SYSLOBSTATS_HIST</u>	SYSHIST	DSNHJX01 (NC)	Contains accumulated rows from SYSLOBSTATS
<u>SYSOBDS</u> "1" on page 2347	SYSALTER	DSNDOB01 (N) DSNDOB02 (N)	Contains one row for each table space or index that can be recovered to an image copy that was made before the first version was generated. Important: Do not manipulate data in the SYSIBM.SYSOBDS catalog table, except at the direction of IBM Support.
<u>SYSOBD_AUX</u> "1" on page 2347	SYTSOBX	DSNOB03 (A)	Contains the LOB data for the OBD_IMAGE column of SYSIBM.SYSOBDS.
<u>SYSOBJROLEDEP</u>	SYSROLES	DSNRDX01 (UC) DSNRDX02 (N)	Contains one row for each dependent role
<u>SYSPACKAGE</u>	SYTSPKG	DSNKKX01 (U) DSNKKX02 (U)	Contains one row for each package
<u>SYSPACKAUTH</u>	SYTSPKA	DSNKAX01 (N) DSNKAX02 (N) DSNKAX03 (N)	Contains the privileges that are held by users over packages
<u>SYSPACKAUTH_H</u>	SYTSPKH	—	Not used
<u>SYSPACKCOPY</u>	SYTSPKC	DSNPCX01 (UC)	
<u>SYSPACKDEP</u>	SYTSPKD	DSNKDX01 (N) DSNKDX02 (N) DSNKDX03 (N)	Records the dependencies of packages on local tables, views, synonyms, table spaces, indexes, aliases, and triggers
<u>SYSPACKLIST</u>	SYTSPKL	DSNKLX01 (N) DSNKLX02 (U)	Contains one row for every package list entry for a plan
<u>SYSPACKSTMT</u>	SYTSPKS	DSNKSX01 (UC)	Contains one row for every SQL statement that belongs to a package
<u>SYSPACKSTMT_STMB</u>	SYTSPVR	DSNKSX02 (A)	Contains the LOB data for the STMTBLOB column of SYSIBM.SYSPACKSTMT.
<u>SYSPACKSTMT_STMT</u>	SYTSPKX	DSNPKX01 (A)	Contains the LOB data for the STATEMENT column of SYSIBM.SYSPACKSTMT.

Table 262. Db2 catalog tables. The qualifier for all catalog table names is SYSIBM. (continued)

Table	Table space	Indexes (Type "2" on page 2347)	Description
<u>SYSPARMS</u>	SYSTSPRM	DSNOPX01 (U) DSNOPX02 (N) DSNOPX03 (N) DSNOPX04 (N)	Contains a row for each parameter of a routine or a row for each column of a table that is passed as a parameter to a routine
<u>SYSPENDINGDDL</u>	SYSTSPEN	DSNPDX01 (N) DSNPDX02 (N)	Contains information about which objects have pending definition changes. The entries exist only during the window between when the pending option is run and when the utility materializes these pending options.
<u>SYSPENDINGDDLTEXT</u>	SYSTSPDT	DSNPDX03 (A)	Contains the LOB data for the STATEMENT_TEXT column of SYSIBM.SYSPENDINGDDL.
<u>SYSPENDINGOBJECTS</u>	SYTSPDO	DSNPOX01 (N) DSNPOX02 (N) DSNPOX03 (N)	Contains name and OBID information about the pending-CREATE objects, whose data sets are created but object definitions have not been materialized to the real catalog.
<u>SYSPKSYSTEM</u>	SYTSPKY	DSNKYX01 (N)	Contain one row of system information for each package
<u>SYSPLAN</u>	SYTSPLN	DSNPPH01 (U)	Contains one row for each application plan
<u>SYSPLANAUTH</u>	SYTSPLA	DSNAPH01 (N) DSNAPX01 (N) DSNAPX02 (N)	Records the privileges that are held by users over application plans
<u>SYSPLANAUTH_H</u>	SYTSPLH	—	Not used
<u>SYSPLANDEP</u>	SYTSPLD	DSNGGX01 (N) DSNGGX05 (N)	Records the dependencies of plans on tables, views, aliases, synonyms, table spaces, and indexes
<u>SYSPLSYSTEM</u>	SYTSPLY	DSNKPX01 (N)	Contains one row of system information for each plan
<u>SYSQUERY</u>	SYTSQLRY	DSNQYX01 (N) DSNQYX02 (U) DSNQYX03 (N) DSNQYX04 (N)	Contains a set of queries
<u>SYSQUERY_AUX</u>	SYTSQLRA	DSNQSX01 (A)	Contains the LOB data for the STMTTEXT column of SYSIBM.SYSQUERY
<u>SYSQUERYOPTS</u>	SYTSQLRO	DSNQPX01 (N)	Contains optimization parameters for the queries in SYSIBM.SYSQUERY.

Table 262. Db2 catalog tables. The qualifier for all catalog table names is SYSIBM. (continued)

Table	Table space	Indexes (Type "2" on page 2347)	Description
<u>SYSQUERYPLAN</u>	SYSTSQRP	DSNQNX01 (N)	Contains the plan hint information for the queries in the SYSIBM.SYSQUERY table
<u>SYSQUERYPREDICATE</u>	SYSTSQRE	DSNQEX01 (UC) DSNQEX02 (N)	Contains rows that describe the predicates within a query. Rows are added to this table by using the BIND QUERY command. Rows are removed from this table by using the FREE QUERY command.
<u>SYSQUERYSEL</u>	SYSTSQRS	—	Contains rows that describe the selectivity of predicates. Rows are added to this table by using the BIND QUERY command. Rows are removed from this table by using the FREE QUERY command.
<u>SYSRELS</u>	SYSTSREL	DSNDLX01 (N) DSNDLX02 (N) DSNDLX03 (N) DSNDLX04 (U)	Contains one row for every relationship
<u>SYSRESAUTH</u>	SYSGPAUT	DSNAGH01 (N) DSNAGX01 (N)	Records the privileges that are held by users over buffer pools, storage groups, table spaces, and collections
<u>SYSRESAUTH_H</u>	SYSTSAAUH	—	Not used
<u>SYSROLES</u>	SYSROLES	DSNRLX01 (UC)	Contains one row for each role
<u>SYSROUTINES</u>	SYSTSROU	DSNOFX01 (U) DSNOFX02 (U) DSNOFX03 (N) DSNOFX04 (U) DSNOFX05 (N) DSNOFX06 (N) DSNOFX07 (U) DSNOFX08 (N)	Contains a row for every routine
<u>SYSROUTINESTEXT</u>	SYSPLUXA	DSNPLX01 (A)	Contains LOB data for the column SYSIBM.SYSROUTINES.TEXT
<u>SYSROUTINES_TREE</u>	SYSPLUXB	DSNPLX02 (A)	Contains the LOB data for the PARSETREE column of SYSIBM.SYSROUTINES.
<u>SYSROUTINEAUTH</u>	SYSTSRAU	DSNOAX01 (N) DSNOAX02 (U) DSNOAX03 (N)	Records the privileges that users hold on routines
<u>SYSROUTINEAUTH_H</u>	SYSTSRAH	—	Not used

Table 262. Db2 catalog tables. The qualifier for all catalog table names is SYSIBM. (continued)

Table	Table space	Indexes (Type "2" on page 2347)	Description
<u>SYSROUTINES_OPTS</u>	SYSGRTNS	DSNROX01 (UC)	Contains one row to record the build options for each generated routine
<u>SYSROUTINES_SRC</u>	SYSGRTNS	DSNRSX01 (N) DSNRSX02 (U)	Contains one or more rows for the source code for each generated routine
<u>SYSSCHEMAAUTH</u>	SYSTSSCM	DSNSKX01 (N) DSNSKX02 (N)	Contains one or more rows for each grantee of a privilege on a schema
<u>SYSSCHEMAAUTH_H</u>	SYSTSSCH	—	Not used
<u>SYSSEQUENCEAUTH</u>	SYSSEQ2	DSNWCX01 (N) DSNWCX02 (N) DSNWCX03 (N)	Records the privileges that users hold on sequences
<u>SYSSEQUENCEAUTH_H</u>	SYTSSAH	—	Not used
<u>SYSSEQUENCES</u>	SYSSEQ	DSNSQX01 (U) DSNSQX02 (UD) DSNSQX03 (N)	Contains one row for each identity column or user-defined sequence.
<u>SYSSEQUENCESDEP</u>	SYSSEQ2	DSNSRX01 (N) DSNSRX02 (N)	Records the dependencies of identity columns on the corresponding entries in SYSIBM.SYSSEQUENCES
<u>SYSSESSION</u>	SYTSSSES	DSNSNX02 (N)	Contains session tokens that are generated by the server and associated session data.
<u>SYSSESSION_EX</u>	SYTSSSNX	DSNSNX04 (U) DSNSNX05 (U)	Contains the global variable data of LOB or array type that corresponds to the locator stored in the GLOBAL_VARIABLES column of SYSSESSION table.
<u>SYSSESSION_GV</u>	SYTSSNL	DSNSNX01 (U)	Contains the LOB data for the GLOBAL_VARIABLES column of SYSIBM.SYSSESSION table.
<u>SYSSESSION_DATA</u>	SYTSSXL	DSNSNX03 (U)	Contains LOB data for the DATA column of the SYSSESSION_EX table.
<u>SYSSESSION_STATUS</u>	SYTSSSTA	DSNSNX06 (U)	Contains the session token and timestamp value when the corresponding session data was last referenced.
<u>SYSSTATFEEDBACK</u>	SYTSSFB	DSNSFX01 (UC)	Contains one row for every missing or conflicting statistic that is identified during query optimization.
<u>SYSSTMT</u>	SYTSSSTM	DSNPSX01 (N) DSNPSX02 (N)	Contains one or more rows for each SQL statement of each DBRM

Table 262. Db2 catalog tables. The qualifier for all catalog table names is SYSIBM. (continued)

Table	Table space	Indexes (Type "2" on page 2347)	Description
<u>SYSSTOGROUP</u>	SYSTSSTG	DSNSSH01 (U)	Contains one row for each storage group
<u>SYSSTRINGS</u>	SYTSSRG	DSNSSX01 (U)	Contains information necessary to perform string translations
<u>SYSSYNONYMS</u>	SYTSSYN	DSNDYX01 (U) DSNDYX02 (N)	Contains one row for each synonym of a table or view
<u>SYSTABAUTH</u>	SYSTSTAU	DSNATX01 (N) DSNATX02 (N) DSNATX03 (N) DSNATX04 (N) DSNATX05 (U)	Records the privileges that are held by users on tables, views, and triggers
<u>SYSTABAUTH_H</u>	SYSTSTBH	—	Not used
<u>SYSTABCONST</u>	SYSTSTBC	DSNCNX01 (U) DSNCNX02 (N)	Contains one row for each unique constraint that was created in Db2 for z/OS DB2 version 7 or later
<u>SYSTABLES</u>	SYSTSTAB	DSNDTX01 (U) DSNDTX02 (N) DSNDTX03 (N) DSNDTX05	Contains one row for each table, view, and alias
<u>SYSTABLES_HIST</u>	SYSHIST	DSNHDX01 (N)	Contains accumulated rows from SYSTABLES
<u>SYSTABLES_PROFILES</u>	SYSTSTPF	DSNPRX01 (UC)	Contains a row for each profile that is associated with a table in SYSIBM.SYSTABLES
<u>SYSTABLES_PROFILE_TEXT</u>	SYSTSPTX	DSNPRX02 (UC)	Contains the LOB data for the PROFILE_TEXT column of SYSIBM.SYSTABLES_PROFILES
<u>SYSTABLEPART</u>	SYSTSTPT	DSNDPX01 (U) DSNDPX02 (N) DSNDPX03 (N) DSNDPX04 (N) DSNDPX05 (N)	Contains one row for each nonpartitioned table space and one row for each partition of a partitioned table space
<u>SYSTABLEPART_HIST</u>	SYSHIST	DSNHDX01 (N)	Contains accumulated rows from SYSTABLEPART
<u>SYSTABLESPACE</u>	SYSTSTSP	DSNDSX01 (U)	Contains one row for each table space
<u>SYSTABLESPACESTATS</u>	SYSTSTSS	DSNRTX01 (U)	Contains Real Time Statistics for table spaces.

Table 262. Db2 catalog tables. The qualifier for all catalog table names is SYSIBM. (continued)

Table	Table space	Indexes (Type "2" on page 2347)	Description
<u>SYSTABSPACESTATS_H</u>	SYSTSTSH		A history table for temporal versioning of the " <u>SYSTABLESPACESTATS catalog table</u> " on page 2699 table. For more information, see " <u>Temporal versioning for Db2 statistics-related catalog tables</u> " on page 2742.
<u>SYSTABSTATS</u>	SYSSTATS	DSNTTX01 (U) DSNTTX02 (N)	Contains one row for each partition of a partitioned table space and no rows for nonpartitioned table spaces
<u>SYSTABSTATS_HIST</u>	SYSHIST	DSNHXB01 (NC)	Contains accumulated rows from SYSTABSTATS
<u>SYSTRIGGERS</u>	SYSTSTRG	DSNOTX01 (UC) DSNOTX02 (N) DSNOTX03 (N)	Contains one row for each trigger
<u>SYSTRIGGERS_STMT</u>	SYSTSTRT	DSNOTX04 (A)	Contains the LOB data for the STATEMENT column of SYSIBM.SYSTRIGGERS
<u>SYSUSERAUTH</u>	SYSUSER	DSNAUH01 (N) DSNAUX02 (N)	Records the system privileges that are held by users
<u>SYSUSERAUTH_H</u>	SYSTSUAH	—	Not used
<u>SYSVARIABLEAUTH</u>	SYSTSVAU	DSNVAX01 (N) DSNVAX02 (N) DSNVAX03 (N)	Contains one row for each authorization ID that has privileges for each global variable.
<u>SYSVARIABLES</u>	SYSTSVAR	DSNOVX01 (U)	Contains one row for each global variable that has been created.
<u>SYSVARIABLES_DESC</u>	SYTSVAD	DSNOVX03 (A)	Contains the LOB data for the DESCRIPTOR column of SYSIBM.SYSVARIABLES.
<u>SYSVARIABLES_TEXT</u>	SYTSVAT	DSNOVX02 (A)	Contains the LOB data for the DEFAULTTEXT column of SYSIBM.SYSVARIABLES.
<u>SYSVIEWS</u>	SYSTSVEW	DSNVVX01 (U)	Contains one or more rows for each view
<u>SYSVIEWS_STMT</u>	SYTSVWT	DSNVWX01 (A)	Contains the LOB data for the STATEMENT column of SYSIBM.SYSVIEWS
<u>SYSVIEWS_TREE</u>	SYTSVTR	DSNVWX02 (A)	Contains the LOB data for the PARSETREE column of SYSIBM.SYSVIEWS

Table 262. Db2 catalog tables. The qualifier for all catalog table names is SYSIBM. (continued)

Table	Table space	Indexes (Type "2" on page 2347)	Description
<u>SYSVIEWDEP</u>	SYSTSVWD	DSNGGX02 (N) DSNGGX03 (N) DSNGGX04 (N) DSNGGX06	Records the dependencies of views on tables and other views
<u>SYSVIEWDEP_H</u>	SYSTSVDH	—	Not used.
<u>SYSVOLUMES</u>	SYSTSVOL	DSNSSH02 (N)	Contains one row for each volume of each storage group
<u>SYSXMLRELS</u>	SYSXML	DSNXRX01 (N) DSNXRX02 (N)	Contains one row for each XML table that is created for an XML column
<u>SYSXMLSTRINGS</u>	SYSXML	DSNXSX01 (UC) DSNXSX02 (U)	Each row holds a single string and its unique ID. They are used to condense XML data. The string can be an element name, attribute name, name space prefix, or a name space URI.
<u>SYSXMLTYPMOD</u>	SYSTSXTM	DSNTMX01 (U)	Contains rows about the XML type modifiers of XML columns. Rows in this table can be inserted, updated, and deleted.
<u>SYSXMLTYPMSHEMA</u>	SYSTSXTS	DSNMSX01 (U) DSNMSX02 (N)	Contain rows about XML schemas for the XML type modifiers that are stored in SYSXMLTYPMOD. Each row contains one XML schema specification for one XML type modifier. Rows in this table can be inserted, updated, and deleted.
<u>USERNAMES</u>	SYSDDF	DSNFEX01 (U)	Contains a row for each authorization ID to be translated or checked as it is sent to or from this Db2

Notes:

1. Descriptions of the SYSIBM.SYSOBDS and SYSIBM.SYSOBD_AUX catalog tables are available only to users who work in enterprises with a Db2 12 license. For more information see "Internal catalog table formats" in Advanced diagnostic information for Db2 12 for z/OS.
2. The following index types are indicated:
 - A** Auxiliary
 - N** Nonunique
 - U** Unique
 - UC** Unique clustering

UD

Unique descending

Related concepts

[Reorganizing the catalog](#)

The REORG TABLESPACE utility can be run on all the table spaces in the catalog database (DSNDB06) to reclaim unused or wasted space, which can affect performance.

Related reference

[SQL statements allowed on the catalog](#)

Certain SQL statements can be used to change the value of certain options for existing catalog indexes, sequences, and table spaces, or to add indexes to any of the catalog tables.

IPLIST catalog table

The IPLIST table allows multiple IP addresses to be specified for a given LOCATION. The schema is SYSIBM.

Insert rows into this table when you want to define a remote Db2 data sharing group. The same value for the IPADDR column cannot appear in both the IPNAMES table and the IPLIST table. Rows in this table can be inserted, updated, and deleted.

Table 263. SYSIBM.IPLIST table column descriptions

Column name	Data type	Description	Use
LINKNAME	VARCHAR(24) NOT NULL	This column is associated with the value specified in the LINKNAME column in the SYSIBM.LOCATIONS table and the SYSIBM.IPNAMES table. The values of the other columns in the SYSIBM.IPNAMES table apply to the server identified by the LINKNAME column in this row.	G
IPADDR	VARCHAR(254) NOT NULL	This column contains an IPv4 or IPv6 address, or fully qualified domain name of a remote TCP/IP host of the server. If WLM Domain Name Server workload balancing is used, this column must contain the member specific domain name. If Dynamic VIPA workload balancing is used, this column must contain the member specific Dynamic VIPA address. The IPADDR column must be specified as follows: <ul style="list-style-type: none">An IPv4 address must be left justified and is represented as a dotted decimal address. For example, '123.456.78.912' would be interpreted as an IPv4 address.An IPv6 address must be left justified and is represented as a colon hexadecimal address. An example of an IPv6 address is '2001:0DB8:0000:0000:0008:0800:200C:417A', which can also be expressed in compressed form as '2001:DB8::8:800:200C:417A'.A domain name is converted to an IP address by the domain name server where a resulting IPv4 or IPv6 address is determined. An example fully qualified domain name is 'stlmvs1.svl.example.com'.	G

Table 263. SYSIBM.IPLIST table column descriptions (continued)

Column name	Data type	Description	Use
IBMREQD	CHAR(1) NOT NULL WITH DEFAULT 'N'	A value of Y indicates that the row was provided with the Db2 product code. For all other values, see Release dependency indicators . The value in this field is not a reliable indicator of release dependencies.	G

IPNAMES catalog table

The IPNAMES catalog table defines the remote DRDA servers Db2 can access using TCP/IP. The schema is SYSIBM.

Rows in this table can be inserted, updated, and deleted.

Table 264. SYSIBM.IPNAMES table column descriptions

Column name	Data type	Description	Use
LINKNAME	VARCHAR(24) NOT NULL	The value specified in this column must match the value specified in the LINKNAME column of the associated row in SYSIBM.LOCATIONS.	G
SECURITY_OUT	CHAR(1) NOT NULL WITH DEFAULT 'A'	This column defines the DRDA security option used for outbound connections when local Db2 SQL applications connect to any remote server associated with this TCP/IP host. For more information about the meanings of these options, see SYSIBM.IPNAMES columns (Managing Security) . A Already verified D User ID with security-sensitive data encryption E Userid, password, and security-sensitive data encryption P Password R RACF PassTicket <i>Security-sensitive data</i> is any input or output data. Examples are rows that are retrieved from a remote server, rows that are sent to the remote server, and SQL statement text.	G

Table 264. SYSIBM.IPNAMES table column descriptions (continued)

Column name	Data type	Description	Use
USERNAMES	CHAR(1) NOT NULL WITH DEFAULT	<p>This column controls outbound authorization ID translation. Outbound translation is performed when an authorization ID is sent by Db2 to a remote server.</p> <p>O An outbound ID is subject to translation. Rows in the SYSIBM.USERNAMES table are used to perform ID translation.</p> <p>No translation or "come from" checking is performed on inbound IDs.</p> <p>S Row in the SYSIBM.USERNAMES table is used to obtain the system AUTHID used to establish a trusted connection.</p> <p>blank No translation occurs.</p> <p>The supported values depend on the IPNAMES, SECURITY_OUT and LOCATIONS.TRUSTED column values. For more information, see "Supported combinations for SECURITY_OUT and USERNAMES column values" in SYSIBM.IPNAMES columns (Managing Security).</p>	G
IBMREQD	CHAR(1) NOT NULL WITH DEFAULT 'N'	<p>A value of Y indicates that the row was provided with the Db2 product code. For all other values, see Release dependency indicators.</p> <p>The value in this field is not a reliable indicator of release dependencies.</p>	G
IPADDR	VARCHAR(254) NOT NULL WITH DEFAULT	<p>This column contains an IPv4 or IPv6 address, or fully qualified domain name of a remote TCP/IP host. The IPADDR column must be specified as follows:</p> <ul style="list-style-type: none"> An IPv4 address must be left justified and is represented as a dotted decimal address. For example, '123.456.78.91' would be interpreted as an IPv4 address. An IPv6 address must be left justified and is represented as a colon hexadecimal address. An example of an IPv6 address is '2001:0DB8:0000:0000:0008:0800:200C:417A', which can also be expressed in compressed form as '2001:DB8::8:800:200C:417A'. A domain name is converted to an IP address by the domain name server where a resulting IPv4 or IPv6 address is determined. An example fully qualified domain name is 'stlmvs1.svl.example.com'. 	G

Related concepts

[SYSIBM.IPNAMES \(Db2 Data Sharing Planning and Administration\)](#)

Related tasks

Establishing remote trusted connections by Db2 for z/OS requesters (Managing Security)

Related reference

[SYSIBM.IPNAMES columns \(Managing Security\)](#)

LOCATIONS catalog table

The LOCATIONS catalog table contains a row for every accessible remote server. The schema is SYSIBM. The row associates a LOCATION name with the TCP/IP or SNA network attributes for the remote server. Requesters are not defined in this table.

Rows in this table can be inserted, updated, and deleted.

Table 265. SYSIBM.LOCATIONS table column descriptions

Column name	Data type	Description	Use
LOCATION	VARCHAR(128) NOT NULL	A unique location name for the accessible server. This is the name by which the remote server is known to local Db2 SQL applications.	G
LINKNAME	VARCHAR(24) NOT NULL	Identifies the VTAM or TCP/IP attributes associated with this location. For any LINKNAME specified, one or both of the following statements must be true: <ul style="list-style-type: none"> A row exists in SYSIBM.LUNAMES whose LUNAME matches the value specified in the SYSIBM.LOCATIONS LINKNAME column. This row specifies the VTAM communication attributes for the remote location. A row exists in SYSIBM.IPNAMES whose LINKNAME matches the value specified in the SYSIBM.LOCATIONS LINKNAME column. This row specifies the TCP/IP communication attributes for the remote location. <p>For accelerators that are defined with an alias (logical name), specify a LINKNAME value of DSNACCELERATORALIAS.</p>	G
IBMREQD	CHAR(1) NOT NULL WITH DEFAULT 'N'	A value of Y indicates that the row was provided with the Db2 product code. For all other values, see Release dependency indicators . The value in this field is not a reliable indicator of release dependencies.	G

Table 265. SYSIBM.LOCATIONS table column descriptions (continued)

Column name	Data type	Description	Use
PORT	VARCHAR(96) NOT NULL WITH DEFAULT	<p>TCP/IP is used for outbound DRDA connections when the following statement is true:</p> <ul style="list-style-type: none"> A row exists in SYSIBM.IPNAMES, where the LINKNAME column matches the value specified in the SYSIBM.LOCATIONS LINKNAME column. <p>If the above mentioned row is found, the value of the PORT column is interpreted as follows:</p> <ul style="list-style-type: none"> If PORT is blank, the default DRDA port (446) is used. If PORT is nonblank, the value specified for PORT can take one of two forms: <ul style="list-style-type: none"> If the value in PORT is left justified with 1-5 numeric characters, the value is assumed to be the TCP/IP port number of the remote database server. Any other value is assumed to be a TCP/IP service name, which can be converted to a TCP/IP port number using the TCP/IP <code>getservbyname</code> socket call. TCP/IP service names are not case sensitive. 	G
TPN	VARCHAR(192) NOT NULL WITH DEFAULT	<p>Used only when the local Db2 begins an SNA conversation with another server. When used, TPN indicates the SNA LU 6.2 transaction program name (TPN) that will allocate the conversation. A length of zero for the column indicates the default TPN. For DRDA conversations, this is the DRDA default, which is X'07F6C4C2'. For Db2 private protocol conversations, this column is not used.</p> <p>When the server is Db2 Server for VSE & VM, TPN should contain the resource ID of that machine.</p>	G
DBALIAS	VARCHAR(128) NOT NULL	<p>Database alias. The name associated with the server. This name is used to access a remote database server. If DBALIAS is blank, the location name is used to access the remote database server. This column does not change the name of any database objects sent to the remote site that contains the location qualifier.</p> <p>This column applies only to DRDA connections.</p> <p>For information about accelerators that are defined with an alias, see Using an alias for an accelerator (Db2 Performance).</p>	G
TRUSTED	CHAR(1) NOT NULL WITH DEFAULT 'N'	<p>Indicates whether the connection to the remote server can be trusted. This is restricted to TCP/IP only. This column is ignored for connections using SNA.</p> <p>Y Location is trusted. Access to the remote location requires trusted context defined at the remote location.</p> <p>N Location is not trusted.</p>	G

Table 265. SYSIBM.LOCATIONS table column descriptions (continued)

Column name	Data type	Description	Use
SECURE	CHAR(1) NOT NULL WITH DEFAULT 'N'	Indicates the use of the Secure Socket Layer (SSL) protocol for outbound DRDA connections when local Db2 applications connects to the remote database server using TCP/IP. Y Indicates a secure connection using SSL is required for the outbound DRDA connection. N Indicates a secure connection is not required for the outbound DRDA connection.	G

LULIST catalog table

The LULIST catalog table allows multiple LU names to be specified for a given LOCATION. The schema is SYSIBM.

Insert rows into this table when you want to define a remote Db2 data sharing group. The same value for LUNAME column cannot appear in both the SYSIBM.LUNAMES table and the SYSIBM.LULIST table. Rows in this table can be inserted, updated, and deleted.

Table 266. SYSIBM.LULIST table column descriptions

Column name	Data type	Description	Use
LINKNAME	VARCHAR(24) NOT NULL	The value of the LINKNAME column in the SYSIBM.LOCATIONS table with which this row is associated. This is also the value of the LUNAME column in the SYSIBM.LUNAMES table. The values of the other columns in the SYSIBM.LUNAMES row apply to the LU identified by the LUNAME column in this row of SYSIBM.LULIST.	G
LUNAME	VARCHAR(24) NOT NULL	The VTAM logical unit name (LUNAME) of the remote database system. This LUNAME must not exist in the LUNAME column of SYSIBM.LUNAMES.	G
IBMREQD	CHAR(1) NOT NULL WITH DEFAULT 'N'	A value of Y indicates that the row was provided with the Db2 product code. For all other values, see Release dependency indicators . The value in this field is not a reliable indicator of release dependencies.	G

LUMODES catalog table

Each row of the LUMODES table provides VTAM with conversation limits for a specific combination of LUNAME and MODENAME. The schema is SYSIBM. The table is accessed only during the initial conversation limit negotiation between Db2 and a remote LU. This negotiation is called *change-number-of-sessions* (CNOS) processing.

Rows in this table can be inserted, updated, and deleted.

Table 267. SYSIBM.LUMODES table column descriptions

Column name	Data type	Description	Use
LUNAME	VARCHAR(24) NOT NULL	LU name of the server involved in the CNOS processing.	G
MODENAME	VARCHAR(24) NOT NULL	Name of a logon mode description in the VTAM logon mode table.	G
CONVLIMIT	SMALLINT NOT NULL	Maximum number of active conversations between the local Db2 and the other system for this mode. Used to override the number in the DSESLIM parameter of the VTAM APPL definition statement for this mode.	G
IBMREQD	CHAR(1) NOT NULL WITH DEFAULT 'N'	A value of Y indicates that the row was provided with the Db2 product code. For all other values, see Release dependency indicators . The value in this field is not a reliable indicator of release dependencies.	G

LUNAMES catalog table

The LUNAMES table must contain a row for each remote SNA client or server that communicates with Db2. The schema is SYSIBM.

Rows in this table can be inserted, updated, and deleted.

Table 268. SYSIBM.LUNAMES table column descriptions

Column name	Data type	Description	Use
LUNAME	VARCHAR(24) NOT NULL	Name of the LU for one or more accessible systems. A blank string indicates the row applies to clients whose LU name is not specifically defined in this table. All other column values for a given row in this table are for clients and servers associated with the row's LU name.	G
SYSMODENAME	VARCHAR(24) NOT NULL WITH DEFAULT	Mode used to establish inter-system conversations. A blank indicates the default mode IBMDB2LM (Db2 private protocol access and for collecting sysplex balancing information from remote data sharing groups). If private protocols are used to access a remote Db2 LU or if the remote LU is a member of a Db2 data sharing group, use a separate mode other than the default mode.	G

Table 268. SYSIBM.LUNAMES table column descriptions (continued)

Column name	Data type	Description	Use
SECURITY_IN	CHAR(1) NOT NULL WITH DEFAULT 'A'	<p>This column defines the security options that are accepted by this Db2 when an SNA client connects to Db2:</p> <p>V</p> <p>The option is "verify". An incoming connection request must include one of the following: a userid and password, a userid and RACF PasSTicket, or a Kerberos security ticket.</p> <p>A</p> <p>The option is "already verified". A request does not need a password, although a password is checked if it is sent.</p> <p>With this option, an incoming connection request is accepted if it includes any of the following: a userid, a userid and password, a userid and RACF PasSTicket, or a Kerberos security ticket.</p> <p>If the USERNAMES column contains 'I' or 'B', RACF is not invoked to validate incoming connection requests that contain only a userid unless one of the following situations is true:</p> <ul style="list-style-type: none"> • The RACF access control authorization exit (DSNX@XAC) is enabled • The IBM supplied RACF SECLABEL resource class is active. 	G

Table 268. SYSIBM.LUNAMES table column descriptions (continued)

Column name	Data type	Description	Use
SECURITY_OUT	CHAR(1) NOT NULL WITH DEFAULT 'A'	<p>This column defines the security option that is used when local Db2 SQL applications connect to any remote server associated with this LUNAME:</p> <p>A</p> <p>The option is "already verified". Outbound connection requests contain an authorization ID and no password.</p> <p>The authorization ID used for an outbound request is either the Db2 user's authorization ID or a translated ID, depending upon the value of the USERNAMES column.</p> <p>R</p> <p>The option is "RACF PassTicket". Outbound connection requests contain a userid and a RACF PassTicket. The server's LU name is used as the RACF PassTicket application name.</p> <p>The authorization ID used for an outbound request is either the Db2 user's authorization ID or a translated ID, depending upon the value of the USERNAMES column.</p> <p>P</p> <p>The option is "password". Outbound connection requests contain an authorization ID and a password. The password is obtained from the SYSIBM.USERNAMES table or RACF, depending upon the value specified in the ENCRYPTPSWDS column.</p> <p>The USERNAMES column must specify 'B' or 'O'.</p>	G
ENCRYPTPSWDS	CHAR(1) NOT NULL WITH DEFAULT 'N'	<p>This column only applies to Db2 for z/OS partners. It is provided to support connectivity to prior releases of Db2 that are unable to support RACF PassTickets.</p> <p>For connections between Version 5 and later, use the SECURITY_OUT='R' option instead of the ENCRYPTPSWDS='Y' option.</p> <p>N</p> <p>No, passwords are not in internal RACF encrypted format. This is the default.</p> <p>Y</p> <p>Yes for outbound requests, the encrypted password is extracted from RACF and sent to the server. For inbound requests, the password is treated as encrypted.</p>	G

Table 268. SYSIBM.LUNAMES table column descriptions (continued)

Column name	Data type	Description	Use
MODESELECT	CHAR(1) NOT NULL WITH DEFAULT 'N'	<p>Whether to use the SYBIBM.MODESELECT table:</p> <p>N Use default modes: IBMDB2LM (for Db2 private protocol) and IBMRDB (for DRDA).</p> <p>Y Searches SYSIBM.MODESELECT for appropriate mode name.</p>	G
USERNAMES	CHAR(1) NOT NULL WITH DEFAULT	<p>This column controls inbound and outbound authorization ID translation, and "come from" checking.</p> <p>Inbound translation and "come from" checking are performed when an authorization ID is received from a remote client.</p> <p>Outbound translation is performed when an authorization ID is sent by Db2 to a remote server.</p> <p>When 'I', 'O', or 'B' is specified in this column, rows in the SYSIBM.USERNAMES table are used to perform ID translation.</p> <p>I An inbound ID is subject to translation and "come from" checking. No translation is performed on outbound IDs.</p> <p>O No translation or "come from" checking is performed on inbound IDs. An outbound ID is subject to translation.</p> <p>B An inbound ID is subject to translation and "come from" checking. An outbound ID is subject to translation.</p> <p>blank No translation occurs.</p>	G
GENERIC	CHAR(1) NOT NULL WITH DEFAULT 'N'	<p>Indicates whether Db2 should use its real LU name or generic LU name to identify itself to the partner LU, which is identified by this row.</p> <p>N The real VTAM LU name of this Db2 subsystem</p> <p>Y The VTAM generic LU name of this Db2 subsystem</p>	G
IBMREQD	CHAR(1) NOT NULL WITH DEFAULT 'N'	<p>A value of Y indicates that the row was provided with the Db2 product code. For all other values, see Release dependency indicators.</p> <p>The value in this field is not a reliable indicator of release dependencies.</p>	G

MODESELECT catalog table

The MODESELECT catalog table associates a mode name with any conversation created to support an outgoing SQL request. The schema is SYSIBM. Each row represents one or more combinations of LUNAME, authorization ID, and application plan name.

Rows in this table can be inserted, updated, and deleted.

Table 269. SYSIBM.MODESELECT table column descriptions

Column name	Data type	Description	Use
AUTHID	VARCHAR(128) NOT NULL WITH DEFAULT	Authorization ID of the SQL request. Blank (the default) indicates that the MODENAME specified for the row is to apply to all authorization IDs.	G
PLANNAME	VARCHAR(24) NOT NULL WITH DEFAULT	Plan name associated with the SQL request. Blank (the default) indicates that the MODENAME specified for the row is to apply to all plan names.	G
LUNAME	VARCHAR(24) NOT NULL	LU name associated with the SQL request.	G
MODENAME	VARCHAR(24) NOT NULL	Name of the logon mode in the VTAM logon mode table to be used in support of the outgoing SQL request. If blank, IBMDB2LM is used for Db2 private protocol connections and IBMRDB is used for DRDA connections.	G
IBMREQD	CHAR(1) NOT NULL WITH DEFAULT 'N'	A value of Y indicates that the row was provided with the Db2 product code. For all other values, see Release dependency indicators . The value in this field is not a reliable indicator of release dependencies.	G

SYSAUDITPOLICIES catalog table

The SYSAUDITPOLICIES table contains one row for each audit policy. The schema is SYSIBM.

A user with SECADM authority has the privilege to select from, insert, update, or delete from this catalog table. A user with SQLADM, system DBADM, DATAACCESS, ACCESSCTRL, SYSCTRL or SYSADM authority has the privilege to select from this catalog table.

If a view is created on this catalog table, the DATAACCESS authority can perform insert, update, and delete on the view to indirectly insert, update, and delete on the catalog table.

Table 270. SYSIBM.SYSAUDITPOLICIES table column descriptions

Column name	Data type	Description	Use
AUDITPOLICYNAME	VARCHAR(128) NOT NULL	Name of the audit policy. The name must be an identifier of 1 to 128 characters and must begin with a letter. Any other values result in an error being returned when audit policy is started.	G
OBJECTSCHEMA	VARCHAR(128) NOT NULL WITH DEFAULT	Schema of the audited object. The object schema only applies to categories, OBJMAINT and EXECUTE.	G

Table 270. SYSIBM.SYSAUDITPOLICIES table column descriptions (continued)

Column name	Data type	Description	Use
OBJECTNAME	VARCHAR(128) NOT NULL WITH DEFAULT	Name of the object. The object name only applies to categories, OBJMAINT and EXECUTE. Object name can be specified using an SQL LIKE predicate. If the object name is specified using an SQL LIKE predicate, it has to be specified as a delimited identifier. The escape character to be used for the SQL LIKE predicate is obtained from RGFESCP subsystem parameter. If not specified, the default escape character is '+'.	G
OBJECTTYPE	CHAR(1) NOT NULL WITH DEFAULT	Type of the object. C Clone table P Implicit table created for XML columns T Table blank All of the above object types All other values Error when audit policy is started The object type only applies to categories, OBJMAINT and EXECUTE	G
CREATEDTS	TIMESTAMP NOT NULL WITH DEFAULT	The time when the row was inserted.	G
ALTEREDTS	TIMESTAMP NOT NULL WITH DEFAULT	The time when the row was last updated.	G
CHECKING	CHAR(1) NOT NULL WITH DEFAULT	Indicates if authorization and authentication failures are audited: A Audit all failures (Authorization and authentication failures) blank Audit none All other values Error when audit policy is started	G

Table 270. SYSIBM.SYSAUDITPOLICIES table column descriptions (continued)

Column name	Data type	Description	Use
VALIDATE	CHAR(1) NOT NULL WITH DEFAULT	Indicates if auditing is enabled for when a trusted connection is established or used by a different user: A Audit all blank Audit none All other values Error when audit policy is started	G
OBJMAINT	CHAR(1) NOT NULL WITH DEFAULT	Indicates if auditing is enabled for when the table that is identified by OBJECTSCHEMA, OBJECTNAME, and OBJECTTYPE columns is altered or dropped: A Audit when the specified table is altered or dropped blank Audit none All other values Error when audit policy is started	G
EXECUTE	CHAR(1) NOT NULL WITH DEFAULT	Indicates the type of auditing that is performed. Auditing is done for every unique operation on a table by an SQL statement with a unique statement ID. The table on which the SQL statement operates is identified by the OBJECTSCHEMA, OBJECTNAME, and OBJECTTYPE columns. A Audit when an operation of any kind is performed on the table during a utility or application process. C Audit when an insert, update, or delete operation is performed on the table during a utility or application process. blank No auditing is done. All other values An error occurs when the audit policy is started.	G
CONTEXT	CHAR(1) NOT NULL WITH DEFAULT	Indicates if auditing is enabled for the start of a utility, a change to a utility object or phase, and the end of utility: A Audit all utilities blank Audit none All other values Error when audit policy is started	G

Table 270. SYSIBM.SYSAUDITPOLICIES table column descriptions (continued)

Column name	Data type	Description	Use
SECMAINT	CHAR(1) NOT NULL WITH DEFAULT	<p>Indicates if auditing is enabled for when a grant or revoke is made or a trusted context is created or altered:</p> <p>A Audit all</p> <p>blank Audit none</p> <p>All other values Error when audit policy is started</p>	G
SYSADMIN	VARCHAR(128) NOT NULL WITH DEFAULT	<p>Indicates if auditing is enabled for when an operation is performed using an administrative authority to perform system administration tasks:</p> <p>blank Audit none</p> <p>* Audit all the authorities</p> <p>I Installation SYSADM</p> <p>L SYSCTRL</p> <p>O SYSOPR</p> <p>R Installation SYSOPR</p> <p>S SYSADM</p> <p>All other values Error when audit policy is started</p> <p>The value of SYSADMIN can be a concatenated string of all supported values. For example, 'LOS' would indicate auditing of any operation that is performed using the administrative authorities: SYSCTRL, SYSOPR, and SYSADM. Multiple occurrences of a value are ignored.</p>	G

Table 270. SYSIBM.SYSAUDITPOLICIES table column descriptions (continued)

Column name	Data type	Description	Use
DBADMIN	VARCHAR(128) NOT NULL WITH DEFAULT	<p>Indicates if auditing is enabled for when an operation is performed using an administrative authority to perform database administration tasks:</p> <p>blank Audit none</p> <p>* Audit all the authorities</p> <p>B System DBADM</p> <p>C DBCTRL</p> <p>D DBADM</p> <p>E SECADM</p> <p>G ACCESSCTRL</p> <p>K SQLADM</p> <p>M DBMAINT</p> <p>P PACKADM</p> <p>T DATAACCESS</p> <p>All other values Error when audit policy is started</p> <p>The value of DBADMIN can be a concatenated string of all supported values. For example, 'BMP' would indicate auditing of any operation that is performed using the administrative authorities: System DBADM, DBMAINT, and PACKADM. Multiple occurrences of a value are ignored.</p>	G
DBNAME	VARCHAR(24) NOT NULL WITH DEFAULT	<p>Database name. The database name can be used to specify the database for auditing DBADM, DBCTRL, and DBMAINT authorities. If the database name is not specified, then all the databases, including implicit databases are audited. If the database name is specified, it only applies to DBADM, DBCTRL, and DBMAINT authorities in category, DBADMIN.</p>	G
COLLID	VARCHAR(128) NOT NULL WITH DEFAULT	<p>Name of the package collection. The package collection can be used to specify the collection name for auditing PACKADM authority. If specified, all packages in that collection are audited. If the collection name is not specified, packages in all collections are audited. If the package collection is specified, it only applies to PACKADM authority in category, DBADMIN.</p>	G

Table 270. SYSIBM.SYSAUDITPOLICIES table column descriptions (continued)

Column name	Data type	Description	Use
DB2START	CHAR(1) NOT NULL WITH DEFAULT	<p>Indicates if audit policies are to be started automatically during Db2 start up. Up to 8 audit policies can be specified.</p> <p>Y Audit policy will be started automatically during Db2 startup.</p> <p>S Audit policy will be started automatically during Db2 startup. The audit policy can be stopped only by a user with SECADM authority.</p> <p>T FL 509 Audit policy will be started automatically during Db2 startup. The audit policy can be modified or stopped only by a user with the required permit to the audit policy profile in an external security product, such as RACF.</p> <p>N Audit policy will not be started automatically during Db2 startup.</p> <p>All other values Error when audit policy is started</p>	G
IBMREQD	CHAR(1) NOT NULL	<p>A value of Y indicates that the row was provided with the Db2 product code. For all other values, see Release dependency indicators.</p> <p>The value in this field is not a reliable indicator of release dependencies.</p>	G
SYS_START	TIMESTAMP(12) NOT NULL GENERATED ALWAYS AS ROW BEGIN	Reserved for future IBM use.The row-begin column of the SYSTEM_TIME period, for system-period data versioning.	G
SYS_END	TIMESTAMP(12) NOT NULL GENERATED ALWAYS AS ROW END	Reserved for future IBM use.The row-end column of the SYSTEM_TIME period, for system-period data versioning.	G
TRANS_START	TIMESTAMP(12) NOT NULL GENERATED ALWAYS AS TRANSACTION START ID	Reserved for future IBM use.	G

SYSAUTOALERTS catalog table

The SYSAUTOALERTS table contains one row for each recommendation from autonomic procedures. The schema is SYSIBM.

Table 271. SYSIBM.SYSAUTOALERTS table column descriptions

Column name	Data type	Description	Use
ALERT_ID	BIGINT NOT NULL GENERATED ALWAYS AS IDENTITY	The ID of the alert described in this row.	G
HISTORY_ENTRY_ID	BIGINT NOT NULL	The ID of the entry in the ADMIN_UTLPROCEDURES_HIST procedure that produced this alert.	G
ACTION	VARCHAR(32) NOT NULL	The type of action requested by this alert.	G
TARGET_QUALIFIER	VARCHAR(128) NOT NULL	The qualifier name of the Db2 object (the database name) to which this alert applies.	G
TARGET_OBJECT	VARCHAR(128) NOT NULL	The name of the Db2 object (the table space name) to which this alert applies.	G
TARGET_PARTITION	SMALLINT NOT NULL	The partition number of the Db2 object to which this alert applies. Zero, if this alert applies to all partitions or if the object is not partitioned.	G
OPTIONS	VARCHAR(4000)	The options that should be specified when the corresponding action is run: USE PROFILE Use the options specified in the profile TABLE Options only apply for this table COLUMNS Options only apply for these columns SAMPLE The table space is too big and sampling is allowed	G
CREATEDTS	TIMESTAMP NOT NULL WITH DEFAULT	The timestamp when the alert was issued.	G
DURATION	INTEGER	An estimate of the time, in seconds, that would be needed to run the corresponding action. If this column contains NULL, the execution plan might overwrite the time window.	G

Table 271. SYSIBM.SYSAUTOALERTS table column descriptions (continued)

Column name	Data type	Description	Use
STATUS	VARCHAR(32)	The status of the actual planned task. Valid values are: OPEN The alert is not yet resolved INPROGRESS The alert execution is in progress COMPLETED The alert execution is complete	G
STARTTS	TIMESTAMP	The timestamp for when the alert execution started. This column contains NULL if the task execution has not yet started.	G
ENDTS	TIMESTAMP	The timestamp for when the alert execution ended. This column contains NULL if the task execution has not yet ended.	G
RETURN_CODE	INTEGER	The return code that is written directly by the autonomic stored procedure that resolved the alert. This column contains NULL if the alert is not yet resolved, if the autonomic stored procedure failed, or if the autonomic stored procedure does not write any return code. A RETURN_CODE of 0 is expected in case of a successful execution.	G
ERROR_MESSAGE	VARCHAR(1331)	An error message that indicates why the alert was not resolved successfully. This column contains NULL if the alert is not yet resolved, or if the autonomic stored procedure that executes the alert does not write any error message. No ERROR_MESSAGE text is expected in case of a successful execution.	G
OUTPUT	CLOB(2M)	The output that is written directly by the autonomic stored procedure that executes the planned task. This column contains NULL if the task is not yet executed, if the execution failed, or if the autonomic stored procedure does not write any output.	G
ROWID	ROWID NOT NULL GENERATED ALWAYS	The ROWID value for the CLOB column of this table.	G

SYSAUTOALERTS_OUT catalog table

The SYSAUTOALERTS_OUT catalog table is an auxiliary table for the OUTPUT column of the SYSAUTOALERTS catalog table. The schema is SYSIBM.

Table 272. SYSIBM.SYSAUTOALERTS_OUT table column descriptions

Column name	Data type	Description	Use
OUTPUT	CLOB(2M)	The output of the autonomic stored procedure.	G

SYSAUTORUNS_HIST catalog table

The SYSAUTORUNS_HIST table contains one row for each time an autonomic procedures has been run. The schema is SYSIBM.

Table 273. SYSIBM.SYSAUTORUNS_HIST table column descriptions

Column name	Data type	Description	Use
HISTORY_ENTRY_ID	BIGINT NOT NULL GENERATED ALWAYS AS IDENTITY	The ID of the entry in the history table.	G
PROC_NAME	VARCHAR(128) NOT NULL	The name of the autonomic stored procedure that produced this entry.	G
STARTTS	TIMESTAMP	The timestamp when the autonomic stored procedure started.	G
ENDTS	TIMESTAMP	The timestamp when the autonomic stored procedure ended.	G
OUTPUT	CLOB(2M)	The output of the autonomic stored procedure.	G
ERROR_MESSAGE	VARCHAR(1331)	An error message that indicates why the autonomic stored procedure was not successful. No ERROR_MESSAGE text is expected in case of a successful execution.	G
RETURN_CODE	INTEGER	The return code written directly by the autonomic stored procedure. This column contains NULL if the autonomic stored procedure execution failed, or if the autonomic stored procedure does not write any return code. A RETURN_CODE of 0 is expected in case of a successful execution.	G
ROWID	ROWID NOT NULL GENERATED ALWAYS	The ROWID value for the OUTPUT column of this table.	G

SYSAUTORUNS_HISTOU catalog table

The SYSAUTORUNS_HISTOU catalog table is an auxiliary table for the OUTPUT column of the SYSIBM.SYSAUTORUNS_HIST table. The schema is SYSIBM.

Table 274. SYSIBM.SYSAUTORUNS_HISTOU table column descriptions

Column name	Data type	Description	Use
OUTPUT	CLOB(2M)	The output of the autonomic stored procedure.	G

SYSAUTOTIMEWINDOWS catalog table

The SYSAUTOTIMEWINDOWS table contains one row for each time period during which autonomic procedures can be run. The schema is SYSIBM.

Table 275. SYSIBM.SYSAUTOTIMEWINDOWS table column descriptions

Column name	Data type	Description	Use
WINDOW_ID	BIGINT NOT NULL GENERATED ALWAYS AS IDENTITY	The ID of the time window described in this row.	G
DB2_SSID	CHAR(4)	The Db2 member name on which the planned tasks have to be run. If this column contains NULL, the tasks in this time window can be run on any Db2 member.	G
MONTH_WEEK	CHAR(1) NOT NULL	Indicates how the value of the DAY column is interpreted: M The value of the DAY column is interpreted as a day of the month W The value of the DAY column is interpreted as a day of the week	G
MONTH	INTEGER	Month in which the time window applies. The value will be from 1 (January) to 12 (December). If this column contains NULL, the time window applies to all months. If MONTH_WEEK is 'W', this column must be NULL.	G
DAY	INTEGER	Day of the month or day of the week for which the time window applies. If this column contains NULL, the time window applies to every day of the month or to every day of the week (depending on the value of the MONTH_WEEK column).	G
FROM_TIME	TIME	The time of day at which the time window begins. If this column contains NULL, no limitation on the time exists. This column will contain NULL if the TO_TIME column contains NULL.	G
TO_TIME	TIME	The time of day at which the time window ends. If this column contains NULL, no limitation on the time exists. This column will contain NULL if the FROM_TIME column contains NULL.	G
ACTION	VARCHAR(256)	The comma-separated list of actions that are allowed during this time window. If this column contains NULL, all actions are allowed.	G

Table 275. SYSIBM.SYSAUTOTIMEWINDOWS table column descriptions (continued)

Column name	Data type	Description	Use
MAX_TASKS	INTEGER	The number of concurrent actions that are allowed during this time window. If this column contains NULL, any number of actions are allowed concurrently.	G

SYSAUXRELS catalog table

The SYSAUXRELS table contains one row for each auxiliary table created for a LOB column. A base table space that is partitioned must have one auxiliary table for each partition of each LOB column. The schema is SYSIBM.

Table 276. SYSIBM.SYSAUXRELS table column descriptions

Column name	Data type	Description	Use
TBOWNER	VARCHAR(128) NOT NULL	The schema of the base table.	G
TBNAME	VARCHAR(128) NOT NULL	Name of the base table.	G
COLNAME	VARCHAR(128) NOT NULL	Name of the LOB column in the base table.	G
PARTITION	SMALLINT NOT NULL	Partition number if the base table space is partitioned. Otherwise, the value is 0.	G
AUXTBOWNER	VARCHAR(128) NOT NULL	The schema of the auxiliary table.	G
AUXTBNAME	VARCHAR(128) NOT NULL	Name of the auxiliary table.	G
AUXRELOBID	INTEGER NOT NULL	Internal identifier of the relationship between the base table and the auxiliary table.	S
IBMREQD	CHAR(1) NOT NULL	A value of Y indicates that the row was provided with the Db2 product code. For all other values, see Release dependency indicators . The value in this field is not a reliable indicator of release dependencies. RELCREATED should be used instead.	G
RELCREATED	CHAR(1) NOT NULL	The release of Db2 that is used to create the object. Blank if created prior to Version 9. See Release dependency indicators for all other values.	G

SYSCHECKDEP catalog table

The SYSCHECKDEP table contains one row for each reference to a column in a check constraint. The schema is SYSIBM.

Table 277. SYSIBM.SYSCHECKDEP table column descriptions

Column name	Data type	Description	Use
TBOWNER	VARCHAR(128) NOT NULL	The schema of the table on which the check constraint is defined.	G
TBNAME	VARCHAR(128) NOT NULL	Name of the table on which the check constraint is defined.	G
CHECKNAME	VARCHAR(128) NOT NULL	Name of the check constraint.	G
COLNAME	VARCHAR(128) NOT NULL	Name of the column that the check constraint refers to.	G
IBMREQD	CHAR(1) NOT NULL	A value of Y indicates that the row was provided with the Db2 product code. For all other values, see Release dependency indicators . The value in this field is not a reliable indicator of release dependencies.	G

SYSCHECKS catalog table

The SYSIBM.SYSCHECKS table contains one row for each check constraint. The schema is SYSIBM.

Table 278. SYSIBM.SYSCHECKS table column descriptions

Column name	Data type	Description	Use
TBOWNER	VARCHAR(128) NOT NULL	The schema of the table on which the check constraint is defined.	G
CREATOR	VARCHAR(128) NOT NULL	Authorization ID of the creator of the check constraint.	G
DBID	SMALLINT NOT NULL	Internal identifier of the database for the check constraint.	S
OBID	SMALLINT NOT NULL	Internal identifier of the check constraint.	S
TIMESTAMP	TIMESTAMP NOT NULL	Time when the check constraint was created.	G
RBA	CHAR(10) NOT NULL FOR BIT DATA	The log RBA when the check constraint was created.	G

Table 278. SYSIBM.SYSCHECKS table column descriptions (continued)

Column name	Data type	Description	Use
IBMREQD	CHAR(1) NOT NULL	A value of Y indicates that the row was provided with the Db2 product code. For all other values, see Release dependency indicators .	G
TBNAME	VARCHAR(128) NOT NULL	Name of the table on which the check constraint is defined.	G
CHECKNAME	VARCHAR(128) NOT NULL	Check constraint name.	G
CHECKCONDITION	VARCHAR(7400) NOT NULL	Text of the check constraint.	G
RELCREATED	CHAR(1) NOT NULL	The release of Db2 that is used to create the object. Blank if created prior to Version 9. See Release dependency indicators for all other values. The value in this field is not a reliable indicator of release dependencies. RELCREATED should be used instead.	G
ENVID	INTEGER NOT NULL WITH DEFAULT	Internal environment identifier.	G
PERIOD	CHAR(1) NOT NULL WITH DEFAULT	The type of period associated with the check constraint: B BUSINESS_TIME check constraint blank Not applicable	G

SYSCHECKS2 catalog table

The SYSCHECKS2 table contains one row for each check constraint for catalog tables created in or after Version 7. The schema is SYSIBM. Check constraints for catalog tables created before Version 7 are not included in this table.

Table 279. SYSIBM.SYSCHECKS2 table column descriptions

Column name	Data type	Description	Use
TBOWNER	VARCHAR(128) NOT NULL	The schema of the table on which the check constraint is defined.	G
TBNAME	VARCHAR(128) NOT NULL	Name of the table on which the check constraint is defined.	G
CHECKNAME	VARCHAR(128) NOT NULL	Check constraint name.	G

Table 279. SYSIBM.SYSCHECKS2 table column descriptions (continued)

Column name	Data type	Description	Use
PATHSCHEMAS	VARCHAR(2048) NOT NULL	SQL path at the time the check constraint was created. The path is used to resolve unqualified cast function names that are used in the constraint definition.	G
IBMREQD	CHAR(1) NOT NULL	A value of Y indicates that the row was provided with the Db2 product code. For all other values, see Release dependency indicators . The value in this field is not a reliable indicator of release dependencies. RELCREATED should be used instead.	G
RELCREATED	CHAR(1) NOT NULL	The release of Db2 that is used to create the object. Blank if created prior to Version 9. See Release dependency indicators for all other values.	G

SYSCOLAUTH catalog table

The SYSCOLAUTH table records the UPDATE or REFERENCES privileges that are held by users on individual columns of a table or view. The schema is SYSIBM.

Column name	Data type	Description	Use
GRANTOR	VARCHAR(128) NOT NULL	Authorization ID or role of the user who granted the privileges. Could also be PUBLIC.	G
GRANTEE	VARCHAR(128) NOT NULL	Authorization ID or role of the user who holds the privilege or the name of an application plan or package that uses the privilege. PUBLIC for a grant to PUBLIC.	G
GRANTEETYPE	CHAR(1) NOT NULL	Type of grantee: blank An authorization ID L Role P An application plan or a package. The grantee is a package if COLLID is not blank.	G
CREATOR	VARCHAR(128) NOT NULL	The schema of the table or view on which the update privilege is held.	G
TNAME	VARCHAR(128) NOT NULL	Name of the table or view.	G
—	CHAR(12) NOT NULL	Internal use only.	I
DATEGRANTED	CHAR(6) NOT NULL	Not used.	N

Column name	Data type	Description	Use
TIMEGRANTED	CHAR(8) NOT NULL	Not used.	N
COLNAME	VARCHAR(128) NOT NULL	Name of the column to which the UPDATE privilege applies.	G
IBMREQD	CHAR(1) NOT NULL	A value of Y indicates that the row was provided with the Db2 product code. For all other values, see Release dependency indicators . The value in this field is not a reliable indicator of release dependencies.	G
LOCATION	VARCHAR(128) NOT NULL WITH DEFAULT	Not used.	N
COLLID	VARCHAR(128) NOT NULL WITH DEFAULT	If GRANTEE is a package, its collection name. Otherwise, the value is blank.	G
CONTOKEN	CHAR(8) NOT NULL WITH DEFAULT FOR BIT DATA	If GRANTEE is a package, the consistency token of the DBRM from which the package was derived. Otherwise, the value is blank.	S
PRIVILEGE	CHAR(1) NOT NULL WITH DEFAULT	Indicates which privilege this row describes: R Row pertains to the REFERENCES privilege. blank Row pertains to the UPDATE privilege.	G
GRANTEDTS	TIMESTAMP NOT NULL WITH DEFAULT	Time when the GRANT statement was executed.	G
GRANTORTYPE	CHAR(1) NOT NULL WITH DEFAULT	Indicates the type of grantor: L Role blank Authorization ID that is not a role	G
SYS_START	TIMESTAMP(12) NOT NULL GENERATED ALWAYS AS ROW BEGIN	Reserved for future IBM use. The row-begin column of the SYSTEM_TIME period, for system-period data versioning.	G
SYS_END	TIMESTAMP(12) NOT NULL GENERATED ALWAYS AS ROW END	Reserved for future IBM use. The row-end column of the SYSTEM_TIME period, for system-period data versioning.	G

Column name	Data type	Description	Use
TRANS_START	TIMESTAMP(12) NOT NULL GENERATED ALWAYS AS TRANSACTION START ID	Reserved for future IBM use.	G

SYSCOLDIST catalog table

The SYSCOLDIST catalog table contains one or more rows for the cardinality, frequency, and histogram statistics for a single column or a column group. The schema is SYSIBM.

Rows in this table can be inserted, updated, and deleted.

Important: Use care when issuing SQL statements or using tools to update statistics values in catalog tables. If such updates introduce invalid data, unpredictable results can occur, including abends for RUNSTATS and other utilities. If such problems occur, you can run the RUNSTATS utility and collect statistics at the table space level to resolve the problems, in most cases.

Column name	Data type	Description	Use
FREQUENCY	SMALLINT NOT NULL	Not used.	N
STATSTIME	TIMESTAMP NOT NULL WITH DEFAULT	If RUNSTATS or another utility with inline statistics updated the statistics, the date and time when the last utility invocation updated the statistics. The default value is '0001-01-01-00.00.00.000000'. The default value indicates that statistics were not collected. This column can be updated.	G
IBMREQD	CHAR(1) NOT NULL	A value of Y indicates that the row was provided with the Db2 product code. For all other values, see Release dependency indicators . The value in this field is not a reliable indicator of release dependencies.	G
TBOWNER	VARCHAR(128) NOT NULL	The schema of the table that contains the column.	G
TBNAME	VARCHAR(128) NOT NULL	Name of the table that contains the column.	G
NAME	VARCHAR(128) NOT NULL	Name of the column. If NUMCOLUMNS is greater than 1, this name identifies the first column name of the set of columns associated with the statistics.	G
COLVALUE	VARCHAR(2000) NOT NULL FOR BIT DATA	Contains the data of a frequently occurring value. Statistics are not collected for an index on a ROWID column. If the value has a non-character data type, the data might not be printable.	S

Column name	Data type	Description	Use
TYPE	CHAR(1) NOT NULL WITH DEFAULT 'F'	The type of statistics gathered: C Cardinality F Frequent value H Histogram Statistics N Non-padded frequent value	G
CARDF	FLOAT NOT NULL WITH DEFAULT -1	For TYPE='C', the number of distinct values for the column group. For TYPE='H', the number of distinct values for the column group in a quantile indicated by QUANTILENO.	S
COLGROUPCOLNO	VARCHAR(254) NOT NULL WITH DEFAULT FOR BIT DATA	Identifies the set of columns associated with the statistics. If the statistics are only associated with a single column, the field contains a zero length. Otherwise, the field is an array of SMALLINT column numbers with a dimension equal to the value in NUMCOLUMNS. This is an updatable column.	S
NUMCOLUMNS	SMALLINT NOT NULL WITH DEFAULT 1	Identifies the number of columns associated with the statistics.	G
FREQUENCYF	FLOAT NOT NULL WITH DEFAULT -1	Gives the percentage of rows in the table with the value specified in COLVALUE when the number is multiplied by 100. For example, a value of '1' indicates 100%. A value of '.153' indicates 15.3%. When TYPE='H', this is the percentage of rows in table which falls at the quantile indicated by QUANTILENO whose range is limited by [LOWVALUE, HIGHVALUE]. Statistics are not collected for an index on a ROWID column.	G
QUANTILENO	SMALLINT NOT NULL WITH DEFAULT -1	Ordinary sequence number of a quantile in the whole consecutive value range, from low to high. This column is not updatable.	G
LOWVALUE	VARCHAR(2000) NOT NULL WITH DEFAULT FOR BIT DATA	For TYPE='H', this is the lower bound for the quantile indicated by QUANTILENO. Not used if TYPE is not 'H'. This column is not updatable.	G
HIGHVALUE	VARCHAR(2000) NOT NULL WITH DEFAULT FOR BIT DATA	For TYPE='H', this is the higher bound for the quantile indicated by QUANTILENO. Not used if TYPE is not 'H'. This column is not updatable.	G

SYSCOLDISTSTATS catalog table

The SYSCOLDISTSTATS catalog table contains zero or more rows per partition for the cardinality, frequency, and histogram statistics for a single column or a column group. The schema is SYSIBM.

No row is inserted if the index is a non-partitioned index. Rows in this table can be inserted, updated, and deleted.

Important: Use care when issuing SQL statements or using tools to update statistics values in catalog tables. If such updates introduce invalid data, unpredictable results can occur, including abends for RUNSTATS and other utilities. If such problems occur, you can run the RUNSTATS utility and collect statistics at the table space level to resolve the problems, in most cases.

Table 280. SYSIBM.SYSCOLDISTSTATS table column descriptions

Column name	Data type	Description	Use
FREQUENCY	SMALLINT NOT NULL	Not used.	N
STATSTIME	TIMESTAMP NOT NULL WITH DEFAULT	If RUNSTATS or another utility with inline statistics updated the statistics, the date and time when the last utility invocation updated the statistics. The default value is '0001-01-01-00.00.00.000000'. The default value indicates that statistics were not collected. This column can be updated.	G
IBMREQD	CHAR(1) NOT NULL	A value of Y indicates that the row was provided with the Db2 product code. For all other values, see Release dependency indicators . The value in this field is not a reliable indicator of release dependencies.	G
PARTITION	SMALLINT NOT NULL	Partition number for the table space that contains the table in which the column is defined.	G
TBOWNER	VARCHAR(128) NOT NULL	The schema of the table that contains the column.	G
TBNAME	VARCHAR(128) NOT NULL	Name of the table that contains the column.	G
NAME	VARCHAR(128) NOT NULL	Name of the column. If NUMCOLUMNS is greater than 1, this name identifies the first column name of the set of columns associated with the statistics.	G
COLVALUE	VARCHAR(2000) NOT NULL FOR BIT DATA	Contains the data of a frequently occurring value. Statistics are not collected for an index on a ROWID column. If the value has a non-character data type, the data might not be printable.	S

Table 280. SYSIBM.SYSCOLDISTSTATS table column descriptions (continued)

Column name	Data type	Description	Use
TYPE	CHAR(1) NOT NULL WITH DEFAULT 'F'	The type of statistics gathered: C Cardinality F Frequent value H Histogram statistics N Non-padded frequent value	G
CARDF	FLOAT NOT NULL WITH DEFAULT -1	If TYPE is C, the value is the number of distinct values for the column group. If TYPE is N or TYPE is F, the value is the number of rows or keys in the partition for which the FREQUENCYF value applies. If TYPE is H, the number of distinct values for the column group in a quantile indicated by QUANTILENO.	S
COLGROUPCOLNO	VARCHAR(254) NOT NULL WITH DEFAULT FOR BIT DATA	Identifies the set of columns associated with the statistics. If the statistics are only associated with a single column, the field contains a zero length. Otherwise, the field is an array of SMALLINT column numbers with a dimension equal to the value in NUMCOLUMNS. This is an updatable column.	S
NUMCOLUMNS	SMALLINT NOT NULL WITH DEFAULT 1	Identifies the number of columns associated with the statistics.	G
FREQUENCYF	FLOAT NOT NULL WITH DEFAULT -1	Gives the percentage of rows in the table with the value specified in COLVALUE when the number is multiplied by 100. For example, a value of '1' indicates 100%. A value of '.153' indicates 15.3%. When TYPE='H', this is the percentage of rows in table which falls in the quantile indicated by QUANTILENO whose range is limited by [LOWVALUE, HIGHVALUE]. Statistics are not collected for an index on a ROWID column.	G
—	VARCHAR(1000) NOT NULL WITH DEFAULT FOR BIT DATA	Internal use only.	I
QUANTILENO	SMALLINT NOT NULL WITH DEFAULT -1	Ordinary sequence number of a quantile in the whole consecutive value range, from low to high. This column is not updatable.	G

Table 280. SYSIBM.SYSCOLDISTSTATS table column descriptions (continued)

Column name	Data type	Description	Use
LOWVALUE	VARCHAR(2000) NOT NULL WITH DEFAULT FOR BIT DATA	For TYPE='H', this is the lower bound for the quantile indicated by QUANTILENO. Not used if TYPE is not 'H'. This column is not updatable.	G
HIGHVALUE	VARCHAR(2000) NOT NULL WITH DEFAULT FOR BIT DATA	For TYPE='H', this is the higher bound for the quantile indicated by QUANTILENO. Not used if TYPE is not 'H'. This column is not updatable.	G

SYSCOLDIST_HIST catalog table

The SYSCOLDIST_HIST catalog table contains rows from the SYSCOLDIST catalog table. The schema is SYSIBM.

Rows are added or changed in this table when RUNSTATS collects history statistics. Rows in this table can also be inserted, updated, and deleted.

Table 281. SYSIBM.SYSCOLDIST_HIST table column descriptions

Column name	Data type	Description	Use
STATSTIME	TIMESTAMP NOT NULL	If RUNSTATS or another utility with inline statistics updated the statistics, the date and time when the last utility invocation updated the statistics. The default value is '0001-01-01-00.00.00.000000'. The default value indicates that statistics were not collected. This column can be updated.	G
TBOWNER	VARCHAR(128) NOT NULL	The schema of the table that contains the column.	G
TBNAME	VARCHAR(128) NOT NULL	Name of the table that contains the column.	G
NAME	VARCHAR(128) NOT NULL	Name of the column. If NUMCOLUMNS is greater than 1, this name identifies the first column name of the set of columns associated with the statistics.	G
COLVALUE	VARCHAR(2000) NOT NULL FOR BIT DATA	Contains the data of a frequently occurring value. Statistics are not collected for an index on a ROWID column. If the value has a non-character data type, the data might not be printable.	S

Table 281. SYSIBM.SYSCOLDIST_HIST table column descriptions (continued)

Column name	Data type	Description	Use
TYPE	CHAR(1) NOT NULL WITH DEFAULT 'F'	The type of statistics gathered: C Cardinality F Frequent value H Histogram Statistics N Non-padded frequent value	G
CARDF	FLOAT(8) NOT NULL WITH DEFAULT -1	When TYPE='C', this is the number of distinct values for the column group. When TYPE='H', this is the number of distinct values for the column group in a quantile indicated by QUANTILENO. The value is -1 if statistics have not been gathered.	S
COLGROUPCOLNO	VARCHAR(254) NOT NULL FOR BIT DATA	Identifies the set of columns associated with the statistics. If the statistics are only associated with a single column, the field contains a zero length. Otherwise, the field is an array of SMALLINT column numbers with a dimension equal to the value in NUMCOLUMNS.	S
NUMCOLUMNS	SMALLINT NOT NULL WITH DEFAULT 1	Identifies the number of columns associated with the statistics.	G
FREQUENCYF	FLOAT(8) NOT NULL DEFAULT -1	Gives the percentage of rows in the table with the value specified in COLVALUE when the number is multiplied by 100. For example, a value of '1' indicates 100%. A value of '.153' indicates 15.3%. When TYPE='H', this is the percentage of rows in table which falls in the quantile indicated by QUANTILENO whose range is limited by [LOWVALUE, HIGHVALUE]. Statistics are not collected for an index on a ROWID column. The value is -1 if statistics have not been gathered.	G
IBMREQD	CHAR(1) NOT NULL DEFAULT 'N'	A value of Y indicates that the row was provided with the Db2 product code. For all other values, see Release dependency indicators . The value in this field is not a reliable indicator of release dependencies.	G
QUANTILENO	SMALLINT NOT NULL WITH DEFAULT -1	Ordinary sequence number of a quantile in the whole consecutive value range, from low to high. This column is not updatable.	G

Table 281. SYSIBM.SYSCOLDIST_HIST table column descriptions (continued)

Column name	Data type	Description	Use
LOWVALUE	VARCHAR(2000) NOT NULL WITH DEFAULT FOR BIT DATA	For TYPE='H', this is the lower bound for the quantile indicated by QUANTILENO. Not used if TYPE is not 'H'. This column is not updatable.	G
HIGHVALUE	VARCHAR(2000) NOT NULL WITH DEFAULT FOR BIT DATA	For TYPE='H', this is the higher bound for the quantile indicated by QUANTILENO. Not used if TYPE is not 'H'. This column is not updatable.	G

SYSCOLSTATS catalog table

The SYSCOLSTATS table contains partition statistics for selected columns. The schema is SYSIBM. For each column, a row exists for each partition in the table.

Rows are inserted when RUNSTATS collects either indexed column statistics or non-indexed column statistics for a partitioned table space. No row is inserted if the table space is nonpartitioned. Rows in this table can be inserted, updated, and deleted.

Important: Use care when issuing SQL statements or using tools to update statistics values in catalog tables. If such updates introduce invalid data, unpredictable results can occur, including abends for RUNSTATS and other utilities. If such problems occur, you can run the RUNSTATS utility and collect statistics at the table space level to resolve the problems, in most cases.

Table 282. SYSIBM.SYSCOLSTATS table column descriptions

Column name	Data type	Description	Use
HIGHKEY	VARCHAR(2000) NOT NULL FOR BIT DATA	Highest value of the column within the partition. Blank if statistics have not been gathered or the column is an indicator column, a node ID column, or a column of an XML table. If the column has a non-character data type, the data might not be printable. If the partition is empty, the value is a string of length 0.	S
HIGH2KEY	VARCHAR(2000) NOT NULL FOR BIT DATA	Second highest value of the column within the partition. Blank if statistics have not been gathered or the column is an indicator column, a node ID column, or a column of an XML table. If the column has a non-character data type, the data might not be printable. If the partition is empty, the value is a string of length 0.	S
LOWKEY	VARCHAR(2000) NOT NULL FOR BIT DATA	Lowest value of the column within the partition. Blank if statistics have not been gathered or the column is an indicator column, a node ID column, or a column of an XML table. If the column has a non-character data type, the data might not be printable. If the partition is empty, the value is a string of length 0.	S
LOW2KEY	VARCHAR(2000) NOT NULL FOR BIT DATA	Second lowest value of the column within the partition. Blank if statistics have not been gathered or the column is an indicator column, a node ID column, or a column of an XML table. If the column has a non-character data type, the data might not be printable. If the partition is empty, the value is a string of length 0.	S

Table 282. SYSIBM.SYSCOLSTATS table column descriptions (continued)

Column name	Data type	Description	Use
COLCARD	INTEGER NOT NULL	Number of distinct column values in the partition.	S
STATSTIME	TIMESTAMP NOT NULL	<p>If RUNSTATS or another utility with inline statistics updated the statistics, the date and time when the last utility invocation updated the statistics. The default value is '0001-01-01-00.00.00.000000'. The default value indicates that statistics were not collected. This column can be updated.</p> <p>The value '0001-01-02-00.00.00.000000' indicates that an ALTER TABLE statement was executed to change the length of a VARCHAR column and RUNSTATS should be run to update the statistics before they are used.</p>	G
IBMREQD	CHAR(1) NOT NULL	<p>A value of Y indicates that the row was provided with the Db2 product code. For all other values, see Release dependency indicators.</p> <p>The value in this field is not a reliable indicator of release dependencies.</p>	G
PARTITION	SMALLINT NOT NULL	Partition number for the table space that contains the table in which the column is defined.	G
TBOWNER	VARCHAR(128) NOT NULL	Schema or qualifier of the table that contains the column.	G
TBNAME	VARCHAR(128) NOT NULL	Name of the table that contains the column.	G
NAME	VARCHAR(128) NOT NULL	Name of the column.	G
—	VARCHAR(1000) NOT NULL FOR BIT DATA	Internal use only.	I
STATS_FORMAT	CHAR(1) NOT NULL WITH DEFAULT	<p>The type of statistics gathered:</p> <p>blank Statistics have not been collected or varchar column statistical values are padded.</p> <p>N Varchar column statistical values are not padded.</p> <p>This is an updatable column.</p>	G

SYSCOLUMNS catalog table

The SYSCOLUMNS table contains one row for every column of each table and view. The schema is SYSIBM.

Table 283. SYSIBM.SYSCOLUMNS table column descriptions

Column name	Data type	Description	Use
NAME	VARCHAR(128) NOT NULL	Name of the column.	G
TBNAME	VARCHAR(128) NOT NULL	Name of the table or view which contains the column.	G
TBCREATOR	VARCHAR(128) NOT NULL	The schema of the table or view that contains the column.	G
COLNO	SMALLINT NOT NULL	Numeric place of the column in the table or view; for example 4 (out of 10).	G

Table 283. SYSIBM.SYSCOLUMNS table column descriptions (continued)

Column name	Data type	Description	Use
COLTYPE	CHAR(8) NOT NULL	<p>The type of the column specified in the definition of the column:</p> <p>INTEGER Large integer</p> <p>SMALLINT Small integer</p> <p>FLOAT Floating-point</p> <p>CHAR Fixed-length character string</p> <p>VARCHAR Varying-length character string</p> <p>LONGVAR Varying-length character string (for columns that were added before Version 9)</p> <p>DECIMAL Decimal</p> <p>GRAPHIC Fixed-length graphic string</p> <p>VARG Varying-length graphic string</p> <p>LONGVARG Varying-length graphic string (for columns that were added before Version 9)</p> <p>DATE Date</p> <p>TIME Time</p> <p>TIMESTAMP Timestamp</p> <p>TIMESTZ Timestamp with time zone</p> <p>BLOB Binary large object</p> <p>CLOB Character large object</p> <p>DBCLOB Double-byte character large object</p> <p>ROWID Row ID data type</p>	G

Table 283. SYSIBM.SYSCOLUMNS table column descriptions (continued)

Column name	Data type	Description	Use
COLTYPE (continued)		<p>DISTINCT Distinct type</p> <p>XML XML data type</p> <p>BIGINT Big integer</p> <p>BINARY Fixed-length binary string</p> <p>VARBIN Varying-length binary string, or a Db2 11 VARCHAR or VARGRAPHIC Unicode column in an EBCDIC table</p> <p>DECFLOAT Decimal floating point</p>	

Table 283. SYSIBM.SYSCOLUMNS table column descriptions (continued)

Column name	Data type	Description	Use
LENGTH	SMALLINT NOT NULL	<p>Length attribute of the column or, in the case of a decimal column, its precision. The number does not include the internal prefixes that are used to record the actual length and null state, where applicable.</p> <p>INTEGER 4</p> <p>SMALLINT 2</p> <p>BIGINT 8</p> <p>FLOAT 4 or 8</p> <p>CHAR Length of string</p> <p>VARCHAR Maximum length of string</p> <p>LONGVAR Maximum length of string (for columns that were added before Version 9)</p> <p>DECIMAL Precision of number</p> <p>DECFLOAT 8 or 16</p> <p>GRAPHIC Number of DBCS characters</p> <p>VARGRAPHIC Maximum number of DBCS characters. For a Db2 11 VARGRAPHIC Unicode column in an EBCDIC table, this value is the maximum number of bytes.</p> <p>LONGVARG Maximum number of DBCS characters (for columns that were added before Version 9)</p> <p>BINARY Length of string</p> <p>VARBINARY Maximum length of string</p> <p>DATE 4</p> <p>TIME 3</p> <p>TIMESTAMP WITHOUT TIME ZONE The integral part of $((p+1)/2) + 7$ where p is the precision of the timestamp</p> <p>TIMESTAMP WITH TIME ZONE The integral part of $((p+1)/2) + 9$ where p is the precision of the timestamp</p>	G

Table 283. SYSIBM.SYSCOLUMNS table column descriptions (continued)

Column name	Data type	Description	Use
LENGTH (continued)	SMALLINT NOT NULL	<p>LOB 4 - For a table, a field of length of 4 is stored in the base table. The maximum length of the LOB column is found in LENGTH2.</p> <p>INLINE LOB Greater than 4 - For a table, a field of length 4 plus the inline length (in byte) is stored in the base table. The maximum length of the LOB column is found in LENGTH2.</p> <p>BLOB 4 - For a table, a field of length of 4 is stored in the base table. The maximum length of the LOB column is found in LENGTH2.</p> <p>CLOB 4 - For a table, a field of length of 4 is stored in the base table. The maximum length of the CLOB column is found in LENGTH2.</p> <p>DBCLOB 4 - For a table, a field of length of 4 is stored in the base table. The maximum length of the DBCLOB column is found in LENGTH2.</p> <p>ROWID 17 - The maximum length of the stored portion of the identifier.</p> <p>XML 6 - If column cannot contain multiple versions of an XML document. 14 - If column can contain multiple versions of an XML document. For more information, see How Db2 uses XML versions (Db2 Programming for XML).</p> <p>DISTINCT The length of the source data type.</p>	G
SCALE	SMALLINT NOT NULL	<p>If the column type is DECIMAL, this value represents the scale. If the column type is timestamp or timestamp with time zone, this value represents the number of fractional second digits. Otherwise the value is 0.</p> <p>If the column is a timestamp type, the LENGTH is 10 and the SCALE is 0, the number of fractional second digits is 6.</p>	G

Table 283. SYSIBM.SYSCOLUMNS table column descriptions (continued)

Column name	Data type	Description	Use
NULLS	CHAR(1) NOT NULL	Whether the column can contain null values: N No Y Yes The value can be N for a view column that is derived from an expression that is not a simple column name or constant, or from a function. Nevertheless, such a column allows nulls when an outer select list refers to it.	G
COLCARD	INTEGER NOT NULL	Not used	N
HIGH2KEY	VARCHAR(2000) NOT NULL FOR BIT DATA	Second highest value of the column. Blank if statistics have not been gathered, or the column is an indicator column or a column of an auxiliary table. If the column has a non-character data type, the data might not be printable. If the table is empty, the value is a string of length 0. This is an updatable column.	S
LOW2KEY	VARCHAR(2000) NOT NULL FOR BIT DATA	Second lowest value of the column. Blank if statistics have not been gathered, or the column is an indicator column or a column of an auxiliary table. If the column has a non-character data type, the data might not be printable. If the table is empty, the value is a string of length 0. This is an updatable column.	S
UPDATES	CHAR(1) NOT NULL	Whether the column can be updated: N No Y Yes The value is N if the column is: <ul style="list-style-type: none"> • Derived from a function or expression • A column with a row ID data type (or a distinct type based on a row ID type) • A read-only view 	G
IBMREQD	CHAR(1) NOT NULL	A value of Y indicates that the row was provided with the Db2 product code. For all other values, see Release dependency indicators . The value in this field is not a reliable indicator of release dependencies.	G
REMARKS	VARCHAR(762) NOT NULL	A character string provided by the user with the COMMENT statement.	G

Table 283. SYSIBM.SYSCOLUMNS table column descriptions (continued)

Column name	Data type	Description	Use
DEFAULT	CHAR(1) NOT NULL	<p>The contents of this column are meaningful only if the TYPE column for the associated SYSTABLES row indicates that this is for a table (T) or a created temporary table (G).</p> <p>Default indicator:</p> <p>A The column is defined as a ROWID with the GENERATED ALWAYS attribute.</p> <p>B The column is defined as a built-in data type with a default value that depends on the data type of the column.</p> <p>D The column is defined as a ROWID with the GENERATED BY DEFAULT attribute.</p> <p>E The column is defined with the FOR EACH ROW ON UPDATE and GENERATED ALWAYS attributes.</p> <p>F The column is defined with the FOR EACH ROW ON UPDATE and GENERATED BY DEFAULT attributes.</p> <p>I The column is defined with the AS IDENTITY and GENERATED ALWAYS attributes.</p> <p>J The column is defined with the AS IDENTITY and GENERATED BY DEFAULT attributes.</p> <p>K The column is defined for the implicit DOCID column for a base table that contains XML data.</p> <p>L The column is defined with the AS SECURITY LABEL attribute.</p> <p>N The column has no default value.</p> <p>Q The column is defined with the AS ROW BEGIN attribute.</p> <p>R The column is defined with the AS ROW END attribute.</p>	G

Table 283. SYSIBM.SYSCOLUMNS table column descriptions (continued)

Column name	Data type	Description	Use
DEFAULT (continued)	CHAR(1) NOT NULL	<p>Default indicator:</p> <p>S The column has a default value that is the value of the SQL authorization ID of the process at the time a default value is used.</p> <p>U The column has a default value that is the value of the SESSION_USER special register at the time a default value is used.</p> <p>X The column is defined with the AS TRANSACTION START ID attribute.</p> <p>Y If the NULLS column is Y, the column has a default value of null. If the NULLS column is N, the default value depends on the data type of the column.</p> <p>Data type Default Value</p> <p>Numeric 0</p> <p>Fixed-length character string Blanks</p> <p>Fixed-length graphic string Blanks</p> <p>Fixed-length binary string Hexadecimal blanks</p> <p>Varying-length string A string length of 0</p> <p>Date The current date</p> <p>Time The current time</p> <p>Timestamp The current timestamp</p> <p>Timestamp with time zone The current timestamp with time zone</p> <p>1 The column has a default value that is the string constant found in the DEFAULTVALUE column of this table row. The column has a graphic data type and has a default value that is the graphic string found in the DEFAULTVALUE column of this table row.</p>	G

Table 283. SYSIBM.SYSCOLUMNS table column descriptions (continued)

Column name	Data type	Description	Use
DEFAULT (continued)	CHAR(1) NOT NULL	<p>Default indicator:</p> <p>2 The column has a default value that is the floating-point constant found in the DEFAULTVALUE column of this table row.</p> <p>3 The column has a default value that is the decimal constant found in the DEFAULTVALUE column of this table row.</p> <p>4 The column has a default value that is the integer constant found in the DEFAULTVALUE column of this table row.</p> <p>5 The column has a default value that is the hexadecimal character string found in the DEFAULTVALUE column of this table row.</p> <p>6 The column has a default value that is the UX string found in the DEFAULTVALUE column of this table row.</p> <p>7 The column has a graphic data type and has a default value that is the character string constant found in the DEFAULTVALUE column of this table row.</p> <p>8 The column has a character data type and has a default value that is the graphic string constant found in the DEFAULTVALUE column of this table row.</p> <p>9 The column has a default value that is the DECFLOAT constant found in the DEFAULTVALUE column of this table row.</p> <p>a The column is defined with an expression that specifies a special register. The default value is the value of the special register.</p> <p>b The column is defined with an expression that specifies a built-in session variable. The default value is the value of the built-in session variable.</p> <p>d The column is defined with the DATA CHANGE OPERATION clause. The default value is an I, U, or D character indicating which data change operation the row represents.</p>	G

Table 283. SYSIBM.SYSCOLUMNS table column descriptions (continued)

Column name	Data type	Description	Use
KEYSEQ	SMALLINT NOT NULL	The numeric position of the column within the primary key of the table. The value is 0 if it is not part of a primary key.	G
FOREIGNKEY	CHAR(1) NOT NULL	Applies to character or CLOB columns, where it indicates the subtype of the data: B BIT data M MIXED data S SBCS data blank Indicates one of the following subtypes: <ul style="list-style-type: none"> MIXED data if the encoding scheme is Unicode, or if the encoding scheme is not Unicode and the value of MIXED DATA on installation panel DSNTIPS is YES SBCS data if the encoding scheme is not Unicode and the value of MIXED DATA on the installation panel DSNTIPS is NO. For views defined prior to Version 7, subtype information is not available and the default (MIXED or SBCS) is used.	G
FLDPROC	CHAR(1) NOT NULL	Whether the column has a field procedure: N No Y Yes blank The column is for a view defined prior to Version 7. Views defined after Version 7 contain Y or N.	G
LABEL	VARCHAR(90) NOT NULL	The column label provided by the user with a LABEL statement; otherwise, the value is an empty string.	G
STATSTIME	TIMESTAMP NOT NULL WITH DEFAULT	If RUNSTATS or another utility with inline statistics updated the statistics, the date and time when the last utility invocation updated the statistics. The default value is '0001-01-01-00.00.00.000000'. The default value indicates that statistics were not collected. This column can be updated. The value '0001-01-02-00.00.00.000000' indicates that an ALTER TABLE statement was executed to change the length of a VARCHAR column and RUNSTATS should be run to update the statistics before they are used.	G

Table 283. SYSIBM.SYSCOLUMNS table column descriptions (continued)

Column name	Data type	Description	Use
DEFAULTVALUE	VARCHAR(1536) NOT NULL WITH DEFAULT	<p>This field is meaningful only if the column being described is for a table (the TYPE column of the associated SYSTABLES row is T for table or G for created temporary table).</p> <p>When the DEFAULT column is 1, 2, 3, 4, 5, 6, 7, 8, or 9, this field contains the default value of the column.</p> <p>If the default value is a string constant or a hexadecimal constant (DEFAULT is 1, 5, 6, 7, or 8 respectively), the value is stored without delimiters.</p> <p>If the default value is a numeric constant (DEFAULT is 2, 3, 4, or 9), the value is stored as specified by the user, including sign and decimal point representation, or special constant values, as appropriate for the constant.</p> <p>When the DEFAULT column is S or U and the default value was specified when a new column was defined with the ALTER TABLE statement, this field contains the value of the CURRENT SQLID or SESSION_USER special register at the time the ALTER TABLE statement was executed. This default value applies only to rows that existed before the ALTER TABLE statement was executed.</p> <p>When the DEFAULT column is L and the column was added as a new column with the ALTER TABLE statement, this field contains the security label of the user at the time the ALTER TABLE statement was executed. This default value applies only to rows that existed before the ALTER TABLE statement was executed.</p> <p>When the DEFAULT column contains a, this field contains the name of the special register.</p> <p>When the DEFAULT column contains b, this field contains the qualified name of the session variable.</p> <p>When the DEFAULT column contains d, this field contains DATA CHANGE OPERATION.</p>	G
COLCARDF	FLOAT NOT NULL WITH DEFAULT	Estimated number of distinct values in the column. For an indicator column, this is the number of LOBs that are not null and have a length greater than zero. The value is -1 if statistics have not been gathered. The value is -2 if the column is a LOB column. This is an updatable column.	S
COLSTATUS	CHAR(1) NOT NULL WITH DEFAULT	<p>Indicates the status of the definition of a column:</p> <p>I The definition is incomplete because a LOB table space, auxiliary table, or index on an auxiliary table has not been created for the column.</p> <p>blank The definition is complete.</p>	G

Table 283. SYSIBM.SYSCOLUMNS table column descriptions (continued)

Column name	Data type	Description	Use
LENGTH2	INTEGER NOT NULL WITH DEFAULT	Maximum length of the data retrieved from the column. Possible values are: 0 Column is not a LOB or ROWID column 40 For a ROWID column, the length of the returned value 1 to 2,147,483,647 bytes For a LOB column, the maximum length	G
DATATYPEID	INTEGER NOT NULL WITH DEFAULT	For a built-in data type, the internal ID of the built-in type. For a distinct type, the internal ID of the distinct type. The DATATYPEID value corresponds to one of the SQLTYPE values in “SQLTYPE and SQLLEN” on page 2322. However, the DATATYPEID value is not a reliable indicator of the nullability of the column. A column with an even DATATYPEID value might allow nulls, and a column with an odd DATATYPEID value might not allow nulls. To determine the nullability of the column, use the NULLS column value. If the column was created prior to DB2 version 6, the value is 0.	S
SOURCETYPEID	INTEGER NOT NULL WITH DEFAULT	For a built-in data type, 0. For a distinct type, the internal ID of the built-in data type upon which the distinct type is based. If the column was created prior to DB2 version 6, the value is 0.	S
TYPESHEMA	VARCHAR(128) NOT NULL WITH DEFAULT 'SYSIBM'	If COLTYPE is 'DISTINCT', the schema of the distinct type. Otherwise, the value is 'SYSIBM'.	G
TYPENAME	VARCHAR(128) NOT NULL WITH DEFAULT	If COLTYPE is 'DISTINCT', the name of the distinct type. Otherwise, the value is the same as the value of the COLTYPE column. TYPENAME is set only for columns created in DB2 version 6 or later. The value for columns created earlier is not filled in.	G
CREATEDTS	TIMESTAMP NOT NULL WITH DEFAULT	Timestamp when the column was created. The value is '0001-01-01.00.00.00.000000' if the column was created prior to migration to DB2 version 6 or if the column is in a catalog table.	G

Table 283. SYSIBM.SYSCOLUMNS table column descriptions (continued)

Column name	Data type	Description	Use
STATS_FORMAT	CHAR(1) NOT NULL WITH DEFAULT	The type of statistics gathered: blank Statistics have not been collected or varchar column statistical values are padded. N Varchar column statistical values are not padded. This is an updatable column.	G
PARTKEY_COLSEQ	SMALLINT NOT NULL WITH DEFAULT	The numeric position of the column within the partitioning key of the table. The value is 0 if it is not part of the partitioning key. This column is applicable only if the table uses table-controlled partitioning.	G
PARTKEY_ORDERING	CHAR(1) NOT NULL WITH DEFAULT	Order of the column in the partitioning key: A Ascending D Descending blank Column is not used as part of a partitioning key This column is applicable only if the table uses table-controlled partitioning.	G
ALTEREDTS	TIMESTAMP NOT NULL WITH DEFAULT	Timestamp when alter occurred.	G
CCSID	INTEGER NOT NULL WITH DEFAULT	CCSID of the column. 0 if the object was created prior to Version 8, or is not a character of graphic string column. CCSID is not 0 if COLTYPE is VARBINARY because the object is a Db2 11 Unicode column in an EBCDIC table.	G
HIDDEN	CHAR(1) NOT NULL WITH DEFAULT 'N'	Indicates whether the column is implicitly hidden: P Partially hidden. The column is implicitly hidden from SELECT *. R Partially hidden. The column is a ROWID column that was explicitly defined with the IMPLICITLY HIDDEN attribute. N Not hidden. The column is visible to all SQL statements.	G
RELCREATED	CHAR(1) NOT NULL	The release of Db2 that is used to create the object. See Release dependency indicators for the values.	G

Table 283. SYSIBM.SYSCOLUMNS table column descriptions (continued)

Column name	Data type	Description	Use
CONTROL_ID	INTEGER NOT NULL WITH DEFAULT	Internal identifier of the column access control mask defined for this column. 0 if no column access control mask is defined for the column.	S
XML_TYPEMOD_ID	INTEGER NOT NULL WITH DEFAULT	The ID of the XML type modifier. It is set to 0 if the column is not an XML column or has no XML type modifier.	G
PERIOD	CHAR(1) NOT NULL WITH DEFAULT	Indicates whether the column is the start or the end of the period for a SYSTEM_TIME or BUSINESS_TIME period: B Column is the start of period BUSINESS_TIME. C Column is the end of period BUSINESS_TIME with an exclusive end point. I Column is the end of period BUSINESS_TIME with an inclusive end point. S Column is the start of period SYSTEM_TIME. T Column is the end of period SYSTEM_TIME. blank Column is not used as either the start or the end of a period.	G
GENERATED_ATTR	CHAR(1) NOT NULL WITH DEFAULT	Indicates the columns generated attribute: A Column is defined as GENERATED_ALWAYS. D Column is defined as GENERATED BY DEFAULT. blank Not applicable or the value of the DEFAULT column is A, D, E, F, I, or J or defined from a prior release of Db2.	G
HASHKEY_COLSEQ	SMALLINT NOT NULL WITH DEFAULT	The column's numeric position within the table's hash key. The value is 0 if the column is not part of the hash key. This column is applicable only if the table that use hash organization.	G

Table 283. SYSIBM.SYSCOLUMNS table column descriptions (continued)

Column name	Data type	Description	Use
ENCODING_SCHEME	CHAR(1) NOT NULL WITH DEFAULT 'E'	Encoding scheme of the column: blank The column has a data type that does not have an encoding scheme, or the column was created prior to Db2 12. A ASCII E EBCDIC U Unicode	G

SYSCOLUMNS_HIST catalog table

The SYSCOLUMNS_HIST catalog table contains rows from SYSCOLUMNS. The schema is SYSIBM.

Rows are added or changed in this table when RUNSTATS collects history statistics. Rows in this table can also be inserted, updated, and deleted.

Table 284. SYSIBM.SYSCOLUMNS_HIST table column descriptions

Column name	Data type	Description	Use
NAME	VARCHAR(128) NOT NULL	Name of the column.	G
TBNAME	VARCHAR(128) NOT NULL	Name of the table or view that contains the column.	G
TBCREATOR	VARCHAR(128) NOT NULL	Schema or qualifier of the table or view that contains the column.	G
COLNO	SMALLINT NOT NULL	Numeric place of the column in the table or view. For example 4 (out of 10).	G

Table 284. SYSIBM.SYSCOLUMNS_HIST table column descriptions (continued)

Column name	Data type	Description	Use
COLTYPE	CHAR(8) NOT NULL	<p>The type of the column specified in the definition of the column:</p> <p>INTEGER Large integer</p> <p>SMALLINT Small integer</p> <p>FLOAT Floating-point</p> <p>CHAR Fixed-length character string</p> <p>VARCHAR Varying-length character string</p> <p>LONGVAR Varying-length character string (for columns that were added before Version 9)</p> <p>DECIMAL Decimal</p> <p>GRAPHIC Fixed-length graphic string</p> <p>VARG Varying-length graphic string</p> <p>LONGVARG Varying-length graphic string (for columns that were added before Version 9)</p> <p>DATE Date</p> <p>TIME Time</p> <p>TIMESTAMP Timestamp</p> <p>TIMESTZ Timestamp with time zone</p> <p>BLOB Binary large object</p> <p>CLOB Character large object</p> <p>DBCLOB Double-byte character large object</p> <p>ROWID Row ID data type</p>	G

Table 284. SYSIBM.SYSCOLUMNS_HIST table column descriptions (continued)

Column name	Data type	Description	Use
COLTYPE (continued)		DISTINCT Distinct type XML XML data type BIGINT Big integer BINARY Fixed-length binary string VARBIN Varying-length binary string DECFLOAT Decimal floating point	

Table 284. SYSIBM.SYSCOLUMNS_HIST table column descriptions (continued)

Column name	Data type	Description	Use
LENGTH	SMALLINT NOT NULL	<p>Length attribute of the column or, in the case of a decimal column, its precision. The number does not include the internal prefixes that are used to record the actual length and null state, where applicable.</p> <p>INTEGER 4</p> <p>SMALLINT 2</p> <p>FLOAT 4 or 8</p> <p>CHAR Length of string</p> <p>VARCHAR Maximum length of string</p> <p>LONGVAR Maximum length of string (for columns that were added before Version 9)</p> <p>DECIMAL Precision of number</p> <p>GRAPHIC Number of DBCS characters</p> <p>VARGRAPHIC Maximum number of DBCS characters</p> <p>LONGVARG Maximum number of DBCS characters (for columns that were added before Version 9)</p> <p>DATE 4</p> <p>TIME 3</p> <p>TIMESTAMP WITHOUT TIME ZONE The integral part of $((p+1)/2) + 7$ where p is the precision of the timestamp</p> <p>TIMESTAMP WITH TIME ZONE The integral part of $((p+1)/2) + 9$ where p is the precision of the timestamp</p> <p>BLOB 4 - The length of the field that is stored in the base table. The maximum length of the LOB column is found in LENGTH2.</p> <p>CLOB 4 - The length of the field that is stored in the base table. The maximum length of the CLOB</p>	G

Table 284. SYSIBM.SYSCOLUMNS_HIST table column descriptions (continued)

Column name	Data type	Description	Use
LENGTH (continued)		<p>DBCLOB 4 - The length of the field that is stored in the base table. The maximum length of the DBCLOB column is found in LENGTH2.</p> <p>ROWID 17 - The maximum length of the stored portion of the identifier.</p> <p>DISTINCT The length of the source data type.</p> <p>XML 6</p> <p>BIGINT 8</p> <p>BINARY The length of the string</p> <p>VARBINARY The maximum length of string</p> <p>DECFLOAT 8 or 16</p>	
LENGTH2	INTEGER NOT NULL	<p>Maximum length of the data retrieved from the column. Possible values are:</p> <p>0 Column is not a LOB or ROWID column</p> <p>40 For a ROWID column, the length of the returned value</p> <p>1–2,147,483,647 bytes For a LOB column, the maximum length</p>	G
NULLS	CHAR(1) NOT NULL	<p>Whether the column can contain null values:</p> <p>N No</p> <p>Y Yes</p>	G
HIGH2KEY	VARCHAR(2000) NOT NULL FOR BIT DATA	Second highest value of the column. Blank if statistics have not been gathered, or the column is an indicator column or a column of an auxiliary table. If the column has a non-character data type, the data might not be printable.	S
LOW2KEY	VARCHAR(2000) NOT NULL FOR BIT DATA	Second lowest value of the column. Blank if statistics have not been gathered, or the column is an indicator column or a column of an auxiliary table. If the column has a non-character data type, the data might not be printable.	S

Table 284. SYSIBM.SYSCOLUMNS_HIST table column descriptions (continued)

Column name	Data type	Description	Use
STATSTIME	TIMESTAMP NOT NULL	If RUNSTATS or another utility with inline statistics updated the statistics, the date and time when the last utility invocation updated the statistics. The default value is '0001-01-01-00.00.00.000000'. The default value indicates that statistics were not collected. This column can be updated. The value '0001-01-02-00.00.00.000000' indicates that an ALTER TABLE statement was executed to change the length of a VARCHAR column and RUNSTATS should be run to update the statistics before they are used.	G
COLCARDF	FLOAT(8) NOT NULL WITH DEFAULT -1	Estimated number of distinct values in the column. For an indicator column, this is the number of LOBs that are not null and have a length greater than zero. The value is -1 if statistics have not been gathered. The value is -2 if the column is a LOB column.	S
IBMREQD	CHAR(1) NOT NULL DEFAULT 'N'	A value of Y indicates that the row was provided with the Db2 product code. For all other values, see Release dependency indicators . The value in this field is not a reliable indicator of release dependencies.	G
STATS_FORMAT	CHAR(1) NOT NULL WITH DEFAULT	The type of statistics gathered: blank Statistics have not been collected or varchar column statistical values are padded. N Varchar column statistical values are not padded. This is an updatable column.	G

SYSCONSTDEP catalog table

The SYSCONSTDEP table records dependencies on check constraints or user-defined defaults for a column. The schema is SYSIBM.

Table 285. SYSIBM.SYSCONSTDEP table column descriptions

Column name	Data type	Description	Use
BNAME	VARCHAR(128) NOT NULL	Name of the object on which the dependency exists.	G
BSCHEMA	VARCHAR(128) NOT NULL	Schema of the object on which the dependency exists.	G
BTYPE	CHAR(1) NOT NULL	Type of object on which the dependency exists: F Function instance	G

Table 285. SYSIBM.SYSCONSTDEP table column descriptions (continued)

Column name	Data type	Description	Use
DTBNAME	VARCHAR(128) NOT NULL	Name of the table to which the dependency applies.	G
DTBCREATOR	VARCHAR(128) NOT NULL	The schema of the table to which the dependency applies.	G
DCONSTNAME	VARCHAR(128) NOT NULL	If DTYPE = 'C', the unqualified name of the check constraint. If DTYPE = 'D', a column name.	G
DTYPE	CHAR(1) NOT NULL	Type of object: C Check constraint D User-defined default constant	G
IBMREQD	CHAR(1) NOT NULL	A value of Y indicates that the row was provided with the Db2 product code. For all other values, see Release dependency indicators . The value in this field is not a reliable indicator of release dependencies.	G
DTBOWNER	VARCHAR(128) NOT NULL WITH DEFAULT	Authorization ID of the owner of the table or a zero length string for tables that were created in a Db2 release prior to Version 9.	G
OWNERTYPE	CHAR(1) NOT NULL WITH DEFAULT	Indicates the type of owner: blank Authorization ID R Role	G

SYSCONTEXT catalog table

The SYSCONTEXT table contains one row for each trusted context. The schema is SYSIBM.

Table 286. SYSIBM.SYSCONTEXT table column descriptions

Column name	Data type	Description	Use
NAME	VARCHAR(128) NOT NULL	Name of the trusted context.	G
CONTEXTID	INTEGER NOT NULL GENERATED ALWAYS AS IDENTITY	Internal context ID.	G

Table 286. SYSIBM.SYSCONTEXT table column descriptions (continued)

Column name	Data type	Description	Use
DEFINER	VARCHAR(128) NOT NULL	Authorization ID or role that defined the trusted context.	G
DEFINERTYPE	CHAR(1) NOT NULL	The type of the definer: L Role blank Authorization ID	G
SYSTEMAUTHID	VARCHAR(128) NOT NULL	The Db2 primary authorization ID that is used to establish the connection. For remote requests, SYSTEMAUTHID is derived from the system user ID that is provided by an external entity, such as a middleware server. For local requests, SYSTEMAUTHID depends on one of the following sources of the address space: BATCH USER parameter on JOB statement RRSAF USER parameter on JOB statement or RACF user TSO TSO logon ID	G
DEFAULTROLE	VARCHAR(128) NOT NULL	Name of the trusted context default role.	G
OBJECTOWNERTYPE	CHAR(1) NOT NULL	Whether the ROLE AS OBJECT OWNER AND QUALIFIER clause is specified in the definition of this trusted context: L ROLE AS OBJECT OWNER AND QUALIFIER is specified. A role owns any object created in the trusted context. The role is used as the default for the CURRENT SCHEMA special register. The role is included in the SQL PATH. blank ROLE AS OBJECT OWNER is not specified. An authorization ID owns any object created in the trusted context.	G
CREATEDTS	TIMESTAMP NOT NULL	The time when the trusted context is created.	G
ALTEREDTS	TIMESTAMP NOT NULL	The time when the trusted context is last altered.	G

Table 286. SYSIBM.SYSCONTEXT table column descriptions (continued)

Column name	Data type	Description	Use
ENABLED	CHAR(1) NOT NULL	The status of the trusted context: Y Enabled N Disabled	G
ALLOWPUBLIC	CHAR(1) NOT NULL	Whether the connection is allowed to be reused for PUBLIC: Y Connection reuse is allowed N Connection reuse is not allowed	G
AUTHENTICATEPUBLIC	CHAR(1) NOT NULL	Whether authentication is required for PUBLIC when ALLOWPUBLIC is Y: Y Authentication token is required for PUBLIC. For local requests, the token is the password. For remote requests, the token can be a password, a RACF passticket, or a KERBEROS token N Authentication is not required	G
RELCREATED	CHAR(1) NOT NULL	The release of Db2 that is used to create the object. See Release dependency indicators for the values.	G
IBMREQD	CHAR(1) NOT NULL	A value of Y indicates that the row was provided with the Db2 product code. For all other values, see Release dependency indicators . The value in this field is not a reliable indicator of release dependencies. RELCREATED should be used instead.	G
REMARKS	VARCHAR(762) NOT NULL	A character string that is provided using the COMMENT statement.	G
DEFAULTSECURITYLABEL	VARCHAR(24) NOT NULL	Name of the context default RACF security label.	G
SYS_START	TIMESTAMP(12) NOT NULL GENERATED ALWAYS AS ROW BEGIN	Reserved for future IBM use.The row-begin column of the SYSTEM_TIME period, for system-period data versioning.	G
SYS_END	TIMESTAMP(12) NOT NULL GENERATED ALWAYS AS ROW END	Reserved for future IBM use.The row-end column of the SYSTEM_TIME period, for system-period data versioning.	G

Table 286. SYSIBM.SYSCONTEXT table column descriptions (continued)

Column name	Data type	Description	Use
TRANS_START	TIMESTAMP(12) NOT NULL GENERATED ALWAYS AS TRANSACTION START ID	Reserved for future IBM use.	G

SYSCONTEXTAUTHIDS catalog table

The SYSCONTEXTAUTHIDS table contains one row for each authorization ID with which the trusted context can be used. The schema is SYSIBM.

Table 287. SYSIBM.SYSCONTEXTAUTHIDS table column descriptions

Column name	Data type	Description	Use
CONTEXTID	INTEGER NOT NULL	The internal trusted context ID.	G
AUTHID	VARCHAR(128) NOT NULL	The primary authorization ID that can reuse a connection. When RACF is used, this is a RACF profile name that contains the primary authorization IDs that are permitted to use the connection in the identified trusted context. A RACF profile name in this column has an ampersand (&) sign as the first character, to distinguish it from an authorization ID.	G
AUTHENTICATE	CHAR(1) NOT NULL	Whether authentication is required for the authorization ID in the AUTHID column: Y Authentication token is required for the authorization ID. For local requests, the token is the password. For remote requests, the token can be a password, a RACF passticket, or a Kerberos token N Authentication is not required	G
ROLE	VARCHAR(128) NOT NULL	The role for the authorization ID in the AUTHID column. The role supersedes the default role that is defined for the trusted context.	G
CREATEDTS	TIMESTAMP NOT NULL	The time when the authorization ID is added to the trusted context.	G
IBMREQD	CHAR(1) NOT NULL	A value of Y indicates that the row was provided with the Db2 product code. For all other values, see Release dependency indicators . The value in this field is not a reliable indicator of release dependencies.	G

Table 287. SYSIBM.SYSCONTEXTAUTHIDS table column descriptions (continued)

Column name	Data type	Description	Use
SECURITYLABEL	VARCHAR(24) NOT NULL	RACF security label for AUTHID. The security label supersedes the default security label, if any, that is defined for the context.	G
SYS_START	TIMESTAMP(12) NOT NULL GENERATED ALWAYS AS ROW BEGIN	Reserved for future IBM use.The row-begin column of the SYSTEM_TIME period, for system-period data versioning.	G
SYS_END	TIMESTAMP(12) NOT NULL GENERATED ALWAYS AS ROW END	Reserved for future IBM use.The row-end column of the SYSTEM_TIME period, for system-period data versioning.	G
TRANS_START	TIMESTAMP(12) NOT NULL GENERATED ALWAYS AS TRANSACTION START ID	Reserved for future IBM use.	G

SYSCONTROLS catalog table

The SYSCONTROLS table contains one row for each row permission and column mask. The schema is SYSIBM.

Table 288. SYSIBM.SYSCONTROLS table column descriptions

Column name	Data type	Description	Use
SCHEMA	VARCHAR(128) NOT NULL	Schema of the row permission or column mask.	G
NAME	VARCHAR(128) NOT NULL	Name of the row permission or column mask.	G
OWNER	VARCHAR(128) NOT NULL	Owner of the row permission or column mask.	G
OWNERTYPE	CHAR(1) NOT NULL	Indicates the type of the owner: blank An authorization ID L Role	G
TBSHEMA	VARCHAR(128) NOT NULL	Schema of the table for which the row permission or column mask is defined.	G
TBNAME	VARCHAR(128) NOT NULL	Name of the table for which the row permission or column mask is defined.	G

Table 288. SYSIBM.SYSCONTROLS table column descriptions (continued)

Column name	Data type	Description	Use
TBCORRELATION	VARCHAR(128) NOT NULL WITH DEFAULT	If specified, the correlation name of the table for which the row permission or column mask is defined. Otherwise, the value is an empty string.	G
COLNAME	VARCHAR(128) NOT NULL	Column name for which the column mask is defined. Blank if this is a row permission.	G
COLNO	SMALLINT NOT NULL	Column number for which the column mask is defined. 0 if this is a row permission.	G
CONTROL_ID	INTEGER NOT NULL GENERATED ALWAYS AS IDENTITY	Internal access control ID.	S
CONTROL_TYPE	CHAR(1) NOT NULL	Indicates the type of the access control object: R Row permission M Column mask	G
ENFORCED	CHAR(1) NOT NULL	Indicates the type of the access enforced by the row permission. Column mask always has a value of 'A'. A All access	G
IMPLICIT	CHAR(1) NOT NULL	Indicates whether the row permission was implicitly created: N The row permission was explicitly created or this is a column mask Y The row permission was implicitly created	G
ENABLE	CHAR(1) NOT NULL	Indicates whether the row permission or the column mask is enabled for access control: N Not enabled Y Enabled	G
STATUS	CHAR(1) NOT NULL	Indicates the status of the row permission or column mask definition: blank The definition of the row permission or column mask is complete. R An error occurred when an attempt was made to regenerate the row permission or column mask.	G

Table 288. SYSIBM.SYSCONROLS table column descriptions (continued)

Column name	Data type	Description	Use
CREATEDTS	TIMESTAMP NOT NULL	The timestamp when the row permission or column mask was created.	G
RELCREATED	CHAR(1) NOT NULL	The release of Db2 in which the row permission or column mask was created. See Release dependency indicators for values.	G
ALTEREDTS	TIMESTAMP NOT NULL	The timestamp when the row permission or column mask was last changed.	G
REMARKS	VARCHAR(762) NOT NULL	A character string provided by using the COMMENT ON statement.	G
IBMREQD	CHAR(1) NOT NULL	A value of Y indicates that the row was provided with the Db2 product code. For all other values, see Release dependency indicators . The value in this field is not a reliable indicator of release dependencies. RELCREATED should be used instead.	G
ENVID	INTEGER NOT NULL	Internal identifier of the environment.	G
ROWID	ROWID	Row identifier to support LOB columns in the table.	G
RULETEXT	CLOB(2MB) NOT NULL	The source text of the search condition or expression portion of the CREATE PERMISSION or CREATE MASK statement. Note: The lowercase letters in ordinary tokens are folded to uppercase in the text. However, lowercase letters in ordinary tokens are folded to uppercase in a C or Java program only if the appropriate precompiler option is specified.	G
DESCRIPTOR	BLOB(2MB) NOT NULL	Internal description of the row permission or column mask	S
SYS_START	TIMESTAMP(12) NOT NULL GENERATED ALWAYS AS ROW BEGIN	Reserved for future IBM use. The row-begin column of the SYSTEM_TIME period, for system-period data versioning.	G
SYS_END	TIMESTAMP(12) NOT NULL GENERATED ALWAYS AS ROW END	Reserved for future IBM use. The row-end column of the SYSTEM_TIME period, for system-period data versioning.	G

Table 288. SYSIBM.SYSCONTROLS table column descriptions (continued)

Column name	Data type	Description	Use
TRANS_START	TIMESTAMP(12) NOT NULL GENERATED ALWAYS AS TRANSACTION START ID	Reserved for future IBM use.	G
REGENERATETS	TIMESTAMP(12) NOT NULL	The time when the object was regenerated. The value is valid only for objects that can be regenerated. If no regeneration has occurred, this column contains the same value as the CREATEDTS column.	G

SYSCOPY catalog table

The SYSCOPY table contains information needed for recovery. The schema is SYSIBM.

Column name	Data type	Description	Use
DBNAME	CHAR(8) NOT NULL	Name of the database.	G
TSNAME	CHAR(8) NOT NULL	Name of the target table space or index space.	G
DSNUM	INTEGER NOT NULL	Data set number within the table space. For partitioned table spaces, this value corresponds to the partition number for a single partition copy, or 0 for a copy of an entire partitioned table space or index space.	G

Column name	Data type	Description	Use
ICTYPE	CHAR(1) NOT NULL	Type of operation: A ALTER B REBUILD INDEX C CREATE D CHECK DATA LOG(NO) (no log records for the range are available for RECOVER utility) E RECOVER (to current point) F COPY FULL YES I COPY FULL NO J REORG TABLESPACE or LOAD REPLACE compression dictionary write to log L SQL (type of operation) M MODIFY RECOVERY utility P RECOVER TOCOPY, RECOVER TOLOGPOINT, or RECOVER TORBA (to a point in time) Q QUIESCE R LOAD REPLACE LOG(YES) S LOAD REPLACE LOG(NO) T TERM UTILITY command V REPAIR CATALOG utility W REORG LOG(NO) X REORG LOG(YES) Y LOAD LOG(NO) Z LOAD LOG(YES)	G
ICDATE	CHAR(6) NOT NULL	Date of the last image copy	N

Column name	Data type	Description	Use
START_RBA	CHAR(10) NOT NULL FOR BIT DATA	<p>An 80-bit positive integer that contains the RBA/LRSN of a point in the Db2 recovery log. (The LRSN is the RBA in a data-sharing environment.)</p> <ul style="list-style-type: none"> For ICTYPE I or F, the starting point for all updates since the image copy was taken For ICTYPE J, the RBA/LRSN of the compression dictionary For ICTYPE M, the RBA of the highest deleted SYSCOPY or SYSLGRNX record For ICTYPE P, the point after the log-apply phase of point-in-time recovery For ICTYPE Q, the point after all data sets have been successfully quiesced For ICTYPE R or S, the end of the log before the start of the LOAD utility and before any data is changed For ICTYPE T, the end of the log when the utility is terminated For other values of ICTYPE, the end of the log before the start of the RELOAD phase of the LOAD or REORG utility. 	G
FILESEQNO	INTEGER NOT NULL	Tape file sequence number of the copy.	G
DEVTYPE	CHAR(8) NOT NULL	Device type the copy is on.	G
IBMREQD	CHAR(1) NOT NULL	<p>A value of Y indicates that the row was provided with the Db2 product code. For all other values, see Release dependency indicators.</p> <p>The value in this field is not a reliable indicator of release dependencies. RELCREATED should be used instead.</p>	G

Column name	Data type	Description	Use
DSNAME	CHAR(44) NOT NULL	<p>For ICTYPE='P' (RECOVER TOCOPY only), 'I', or 'F', DSNAME contains the data set name. Otherwise, DSNAME contains the name of the database and table space or index space in the form, <i>database-name.space-name</i>, or DSNAME is blank for any row migrated from a release prior to Version 4. For redirected recoveries, DSNAME contains the source table space or index space name, in the form, <i>database-name.space-name</i>.</p> <p>FL 508 A SYSCOPY record with ICTYPE='W' and STYPE='M' for the target table space indicates that a REORG moved a table into the target table space. In this case, the DSNAME column contains the name of the source table space, <i>database-name.tablespace-name</i>. The DBNAME column contains the name of the target database, <i>database-name</i>, and the TSNAME column contains the name of the target table space, <i>tablespace-name</i>.</p>	G
ICTIME	CHAR(6) NOT NULL	Time of the last image copy.	N
SHRLEVEL	CHAR(1) NOT NULL	<p>SHRLEVEL parameter value on COPY (for ICTYPE F or I only):</p> <p>C CHANGE</p> <p>R REFERENCE</p> <p>blank Does not describe an image copy or was migrated from Version 1 Release 1 of Db2.</p>	G

Column name	Data type	Description	Use
DSVOLSER	VARCHAR(1784) NOT NULL	<p>If the operation is not an image copy operation that creates a FlashCopy image copy with consistency (an image copy operation with the FLASHCOPY CONSISTENT option), this value is:</p> <ul style="list-style-type: none"> • A comma-separated list of 6-byte volume serial numbers of the data set, if the data set is not cataloged. • Blank if the data set is cataloged. <p>If the operation is a FlashCopy image copy with consistency that had uncommitted units of work backed out or a sequential image copy that was created from such a FlashCopy image copy by COPY or COPYTOCOPY, this value is a comma-separated list of values in one of the following forms:</p> <p><i>memberID-ckptrba</i> This format is used for SYSCOPY records that were inserted before SYSCOPY was converted to the Db2 11 enabling-new-function mode format. <i>ckptrba</i> is the 12-byte hexadecimal checkpoint RBA for the member.</p> <p><i>memberID+ckptrba</i> This format is used for SYSCOPY records that were inserted after SYSCOPY was converted to the Db2 11 new-function mode format or later.</p> <p><i>ckptrba</i> is the 20-byte hexadecimal checkpoint RBA for the member.</p> <p><i>memberID</i> is a 3-digit ID for a member of a data sharing group. For a non-data sharing environment, <i>memberID</i> is 000.</p>	G
TIMESTAMP	TIMESTAMP NOT NULL WITH DEFAULT	The date and time when the row was inserted. For the COPYTOCOPY utility, this value is the date and time when the row was inserted for the primary local site or primary recovery site copy. For an EXCHANGE DATA statement, this is the time that the statement is run.	G

Column name	Data type	Description	Use
ICBACKUP	CHAR(2) NOT NULL WITH DEFAULT	<p>Specifies the type of image copy contained in the data set:</p> <p>blank LOCALSITE primary copy (first data set named with COPYDDN)</p> <p>FC FlashCopy copy</p> <p>LB LOCALSITE backup copy (second data set named with COPYDDN)</p> <p>RP RECOVERYSITE primary copy (first data set named with RECOVERYDDN)</p> <p>RB RECOVERYSITE backup copy (second data set named with RECOVERYDDN)</p>	G
ICUNIT	CHAR(1) NOT NULL WITH DEFAULT	<p>Indicates the media that the image copy data set is stored on:</p> <p>D DASD</p> <p>T Tape</p> <p>blank Medium is neither tape nor DASD, the image copy is from a Db2 release prior to Version 2 Release 3, or ICTYPE is not 'I' or 'F'.</p>	G

Column name	Data type	Description	Use
STYPE	CHAR(1) NOT NULL WITH DEFAULT	<p>When ICTYPE=A, the values are:</p> <p>A A partition was added or inserted to a table.</p> <p>B The MEMBER CLUSTER value was changed.</p> <p>C A column was added to a table and an index in different commit scopes, index compression was activated or deactivated, or a column was dropped from a table.</p> <p>A column was added to a table and an index in different commit scopes, or a column was dropped from a table.</p> <p>D Either the DSSIZE attribute of the table space was altered or the default value of a column of a table was altered.</p> <p>E The data set numbers of a base table and its associated clone table are exchanged.</p> <p>F The page size attribute of the table space or index was altered.</p> <p>G An index was regenerated</p> <p>H The table was altered to hash organization, the size of the hash space was changed, or the hash organization was dropped. The value of the TTYPE column indicates the action taken.</p> <p>I The inline length attribute of the LOB column was altered by REORG.</p> <p>L The logging attribute of the table space was altered to LOGGED.</p> <p>M The MAXPARTITIONS attribute of the table space was altered.</p> <p>N An index was altered to not padded</p> <p>O The logging attribute of the table space was altered to NOT LOGGED.</p> <p>P An index was altered to padded</p> <p>R A table was altered to rotate partitions.</p>	G

Column name	Data type	Description	Use
STYPE (continued)		<p>When ICTYPE=A, the values are (continued):</p> <p>S The SEGSIZE attribute of the table space was altered.</p> <p>T <u>FL 508 A</u> table space attribute was altered.</p> <p>U An ALTER TABLE ALTER COLUMN DROP DEFAULT statement was executed on a column that was previously added with an ALTER TABLE ADD COLUMN statement.</p> <p>V A column in a table was altered for a numeric data type change and the column is in an index.</p> <p>X A REORG dropped one or more empty partitions from the related table space.</p> <p>Y An index was altered to COPY YES</p> <p>Z A column that is in the key of an index that was versioned prior to DB2 version 8 was altered.</p> <p>When ICTYPE=C, the values are:</p> <p>L The logging attribute of the table space was LOGGED.</p> <p>O The logging attribute of the table space was NOT LOGGED.</p> <p>When ICTYPE=E, the values are:</p> <p>B RECOVER utility with the BACKOUT keyword.</p> <p>blank RECOVER utility without the BACKOUT keyword.</p> <p>When ICTYPE=F, the values are:</p> <p>C DFSMS concurrent copy ("I" instance of the table space)</p> <p>J DFSMS concurrent copy ("J" instance of the table space)</p> <p>N A FlashCopy copy is not consistent.</p> <p>Q Sequential copy is consistent</p>	

Column name	Data type	Description	Use
STYPE (continued)		<p>When ICTYPE=F, the values are (continued):</p> <p>R LOAD REPLACE(YES)</p> <p>S LOAD REPLACE(NO)</p> <p>T FlashCopy copy is consistent.</p> <p>U Sequential copy is not consistent</p> <p>V ALTER INDEX NOT PADDED</p> <p>W REORG LOG(NO)</p> <p>X REORG LOG(YES)</p> <p>Y LOAD RESUME YES LOG(NO)</p> <p>Z LOAD RESUME YES LOG(YES)</p> <p>blank Db2 image copy</p> <p>When ICTYPE=L, the value is:</p> <p>M Mass DELETE, TRUNCATE TABLE, DROP TABLE, or ALTER TABLE ROTATE PARTITION. The LOWDSNUM column contains the table OBID of the affected table.</p> <p>The MERGECOPY utility, when used to merge an embedded copy with subsequent incremental copies, also produces a record that contains ICTYPE=F and the STYPE of the original image copy (R, S, W, or X).</p> <p>When ICTYPE = M and the MODIFY RECOVERY utility was executed to delete SYSCOPY and/or SYSLGRNX records, the value is R.</p> <p>When ICTYPE=O, the values are:</p> <p>B A table space or partition that was in reordered row format was recovered to a point in time when it was in basic row format.</p> <p>R A table space or partition was converted to reordered row format as a result of REORG or LOAD REPLACE.</p>	

Column name	Data type	Description	Use
STYPE (continued)		<p>When ICTYPE=P, the values are:</p> <p>B RECOVER with the BACKOUT YES option.</p> <p>C RECOVER without using LOGONLY with consistency.</p> <p>F Indicates RECOVER using FROM , where the table space was recovered using recovery resources from a different source table space.</p> <p>J RECOVER using LOGONLY without consistency and using the ENFORCE NO option.</p> <p>K RECOVER without using LOGONLY or the BACKOUT YES and the ENFORCE NO options.</p> <p>L RECOVER using LOGONLY without consistency.</p> <p>M RECOVER using LOGONLY with consistency.</p> <p>blank RECOVER without using LOGONLY without consistency.</p> <p>When ICTYPE=Q and option WRITE(YES) is in effect when the quiesce point is taken, the value is W.</p> <p>When ICTYPE=R or S, the values are:</p> <p>A Resetting REORG pending status</p> <p>T First materializing the default value for a row change timestamp column</p> <p>When ICTYPE=T, this field indicates which COPY utility was terminated by the TERM UTILITY command or the START DATABASE command with the ACCESS(FORCE) option. The values are:</p> <p>F COPY FULL YES</p> <p>When ICTYPE=T, the values are (continued):</p> <p>I COPY FULL NO</p>	

Column name	Data type	Description	Use
SType (continued)		<p>When ICTYPE=W, the values are:</p> <p>M FL 508 REORG on the source table space materialized an ALTER TABLESPACE MOVE TABLE statement</p> <p>When ICTYPE=W or X, the values are:</p> <p>A Resetting REORG pending status or REBALANCE</p> <p>T First materializing the default value for a row change timestamp column</p> <p>For other values of ICTYPE, the value is blank.</p>	
PIT_RBA	CHAR(10) NOT NULL WITH DEFAULT FOR BIT DATA	<p>The meaning of the value depends on the value of the ICTYPE column:</p> <p>ICTYPE='P' The LRSN for the point in the Db2 log. (The LRSN is the RBA in a non-data-sharing environment) The value indicates the stop location of a point-in-time recovery.</p> <p>If a record contains ICTYPE='P' and PIT_RBA=X'000000000000', the copy pending status is active and a full image copy is required. If such a record is encountered during fallback processing of RECOVER, the recover job fails, and a point-in-time recovery is required. PIT_RBA can be zero if the point-in-time recovery is completed by the fall-back processing of RECOVER, or if ICTYPE=P from a prior release of Db2.</p> <p>ICTYPE='F' or 'I' and SHRLEVEL='C' The current RBA or LRSN that corresponds to the point in the Db2 log when the SHRLEVEL CHANGE copy completes.</p> <p>ICTYPE='F', SHRLEVEL='R' or 'C', and ICBACKUP='FC' The RBA or LRSN that corresponds to the point in the Db2 log when the FlashCopy completes.</p> <p>CTYPE='F' and SHRLEVEL 'R' or 'C', STYPE= 'T', 'N', 'Q', or 'U' The RBA or LRSN that corresponds to the point in the Db2 log when the FlashCopy completes.</p> <p>ICTYPE=J The RBA where the compression dictionary is written to the log. In data sharing environments, it is the RBA of the member writing to the log.</p> <p>ICTYPE='M' The RBA/LRSN for the end of the log when the utility completes.</p> <p>For other all other ICTYPE values, this field contains X'00000000000000000000'.</p>	G

Column name	Data type	Description	Use
GROUP_MEMBER	CHAR(8) NOT NULL WITH DEFAULT	The Db2 data sharing member name of the Db2 subsystem that performed the operation. This column is blank if the Db2 subsystem was not in a Db2 data sharing environment at the time the operation was performed.	G
OTYPE	CHAR(1) NOT NULL WITH DEFAULT 'T'	Type of object that the recovery information is for: I Index space T Table space	G
LOWDSNUM	INTEGER NOT NULL WITH DEFAULT	Partition number of the lowest partition in the range for SYSCOPY records created for REORG and LOAD REPLACE for resetting a REORG pending status. Version number of an index for SYSCOPY records created for a COPY (ICTYPE=F) of an index space (OTYPE=I). (An index is versioned when a VARCHAR column in the index key is lengthened.) <ul style="list-style-type: none"> When ICTYPE = F or I, DSNUM = 0 and OTYPE is not equal to I, LOWDSNUM = 1. When ICTYPE=A and STYPE=X, this value is the lowest partition number that was dropped by REORG. 	G
HIGHDSNUM	INTEGER NOT NULL WITH DEFAULT	Partition number of the highest partition in the range. This column is valid only for SYSCOPY records created for REORG and LOAD REPLACE for resetting REORG pending status. <ul style="list-style-type: none"> When ICTYPE = F or I, DSNUM = 0 and OTYPE is not equal to I, this value is the number of the highest partition that is copied. When ICTYPE=A and STYPE=X, this value is the highest partition number that was dropped by REORG. 	G
COPYPAGESF	FLOAT(8) NOT NULL WITH DEFAULT -1	Number of pages written to the copy data set. For inline copies, this number might include pages appearing more than once in the copy data set.	G
NPAGESF	FLOAT(8) NOT NULL WITH DEFAULT -1	The number of pages in the table space or index at the time of COPY. This number might include pre-formatted pages that are not actually copied. When ICTYPE=A, SYTPE=H, and TTYPE=S or D , this column contains the previous HASHDATAPAGES value. When ICTYPE=A, SYTPE=H, and TTYPE=A this column contains zero.	G
CPAGESF	FLOAT(8) NOT NULL WITH DEFAULT -1	Total number of changed pages since last copy.	G

Column name	Data type	Description	Use
JOBNAME	CHAR(8) NOT NULL WITH DEFAULT	Job name of the utility. For changes that cause pending definition changes to object, this column might not be accurate.	G
AUTHID	CHAR(8) NOT NULL WITH DEFAULT	Authorization ID of the utility. For changes that cause pending definition changes to object, this column might not be accurate.	G
OLDEST_VERSION	SMALLINT NOT NULL WITH DEFAULT	<p>When ICTYPE= B, F, I, R, S, W, or X:</p> <ul style="list-style-type: none"> • For a single-table table space, this value is the version number of the oldest format of data for an object. • For a multiple-table table space: <ul style="list-style-type: none"> – A value of zero indicates that there is a least one table in the table space that has data rows in version 0 format. – When ICTYPE=B, F, I, W, or X, a value greater than 0 is the oldest version for tables that are not at version 0. Any tables that are at version 0 have system pages for a version 0 format. – When ICTYPE=R or S: <ul style="list-style-type: none"> - A value greater than 0 is the oldest version for tables that are not at version 0. Any tables that are at version 0 have system pages for a version 0 format. - A value of -1 means that the oldest version number cannot be determined. <p>For other values of ICTYPE, the value is -1. The default value of this column is 0.</p>	G
LOGICAL_PART	INTEGER NOT NULL WITH DEFAULT	Logical partition number.	G
LOGGED	CHAR(1) NOT NULL WITH DEFAULT	<p>Indicates the logging attribute of the table space at the time the SYSCOPY record is written:</p> <ul style="list-style-type: none"> • Y – indicates that the logging attribute of the table space is LOGGED • N – indicates that the logging attribute of the table spaces is NOT LOGGED • blank – indicates that the row was inserted prior to DB2 9 or is not specified. For non-LOB table spaces or an index space, blank indicates that the logging attribute is LOGGED. 	G

Column name	Data type	Description	Use
TTYPE	CHAR(8) NOT NULL WITH DEFAULT	<p>The value of TTYPE column indicates different information depending on the values of the ICTYPE, STYPE, and in some cases, OTYPE column.</p> <p>When ICTYPE=A and STYPE=B:</p> <p>Y The previous member cluster attribute of the table space is being used.</p> <p>N The previous member cluster attribute of the table space is not being used.</p> <p>When ICTYPE=A and STYPE=C:</p> <p>blank A column was added to a table.</p> <p>D A column was dropped from a table.</p> <p>CMP=N Index compression was activated with the ALTER INDEX COMPRESS YES statement.</p> <p>CMP=Y Index compression was deactivated with the ALTER INDEX COMPRESS NO statement.</p> <p>When ICTYPE=A and STYPE=D:</p> <p>x The previous DSSIZE attribute value for the table space in units of G, M, or K.</p> <p>blank The default value of a column of a table was altered.</p> <p>When ICTYPE=A and STYPE=F:</p> <p>x The previous page size attribute value for the table space in units of K.</p> <p>When ICTYPE=A and STYPE=H:</p> <p>A Hash organization was added. The record is written when the hash space is materialized at REORG.</p> <p>D Hash organization was dropped. The record is written immediately when the ALTER statement is issued.</p> <p>S The size of the hash space was changed. The value of the NAPGESF column contains the previous HASHDATAPAGES value. The record is written when the hash space is materialized at REORG.</p>	G

Column name	Data type	Description	Use
TTYPE (continued)		<p>When ICTYPE=A and STYPE=I:</p> <p>D REORG decremented the inline length of the LOB column</p> <p>I REORG incremented the inline length of the LOB column</p> <p>When ICTYPE=A and STYPE=M:</p> <p>I The table space was converted from a single-table simple table space to a partition-by-growth table space.</p> <p>n The previous value of the MAXPARTITIONS attribute for the table space.</p> <p>S The table space was converted from single-table segmented table space to a partition-by-growth table space.</p> <p>When ICTYPE=A and STYPE=P:</p> <p>ABSOLUTE The table space was converted from absolute to relative page numbering.</p> <p>When ICTYPE=A and STYPE=S:</p> <p>n The previous value of the SEGSIZE attribute for the table space.</p> <p>P The table space was converted from a partitioned (non-UTS) table space to a partition-by-range table space.</p> <p><u>FL 508</u> When ICTYPE=A and STYPE=T:</p> <p>M One or more tables were moved by the ALTER TABLESPACE MOVE TABLE statement</p> <p>When ICTYPE=E:</p> <p>blank The full recovery reset the object</p> <p>N The full recovery did not reset the object</p>	

Column name	Data type	Description	Use
TTYPE (continued)		<p>When ICTYPE=F and OTYPE=I:</p> <p>S indicates that the directory pages for the index image copy are at the front of each partition and are indicated with a 'V' or '8'.</p> <p>When ICTYPE=F and STYPE=N, Q, T, or U, this column indicates the utility that made the FlashCopy:</p> <p>A LOAD RESUME LOG NO</p> <p>B REBUILD</p> <p>C COPY</p> <p>D LOAD RESUME LOG YES</p> <p>E LOAD SHRLEVEL CHANGE</p> <p>L LOAD</p> <p>P REPAIR</p> <p>R LOAD REPLACE LOG YES</p> <p>S LOAD REPLACE LOG NO</p> <p>T COPYTOCOPY</p> <p>W REORG TABLESPACE LOG NO</p> <p>X REORG TABLESPACE LOG YES</p> <p>When ICTYPE=F and STYPE=R, S, Y, or Z:</p> <p>V This inline sequential image copy created by LOAD contains pages updated during the INDEXVAL and ENFORCE phases. Rows that were loaded with unique index violations, referential constraint violations, or index evaluation errors were removed from pages in the image copy.</p>	

Column name	Data type	Description	Use
TTYPE (continued)		<p>When ICTYPE=I:</p> <p>N Indicates that no system pages are in this incremental image copy.</p> <p>blank Indicates that system pages are in this incremental image copy.</p> <p>I Indicates that the incremental copy was created for a table space or partition with the TRACKMOD YES attribute using the RBA or LRSN in each page instead of the modified page indicator bits in the space map pages.</p> <p>When ICTYPE=P, R, S, W, X, this column provides additional diagnostic information:</p> <p>B Indicates that the RBA or LRSN format changed to basic 6-byte format.</p> <p>BRF Indicates that the row format is the basic row format.</p> <p>BRF I Indicates that the row format is the basic row format, and the FORMAT INTERNAL option was specified.</p> <p>E Indicates that the RBA or LRSN format changed to extended 10-byte format.</p> <p>F Indicates that the REORG utility was run with the FASTSWITCH YES option.</p> <p>RRF I Indicates that the row format is the reordered row format, and the FORMAT INTERNAL option was specified.</p> <p>S Indicates that the REORG utility was run with the FASTSWITCH NO option.</p> <p>When ICTYPE=M and STYPE=R:</p> <p>blank MODIFY RECOVERY deleted rows from SYSIBM.SYSLGRNX.</p> <p>N MODIFY RECOVERY did not delete rows from SYSIBM.SYSLGRNX.</p>	

Column name	Data type	Description	Use
TTYPE (continued)		<p>When ICTYPE=T:</p> <p>B Indicates that a broken page was detected during copy.</p> <p>When ICTYPE=W or X and STYPE=H:</p> <p>n the previous value of HASHDATAPAGES</p> <p>When ICTYPE=Y or Z:</p> <p>blank Indicates that the FORMAT INTERNAL option was not specified during LOAD.</p> <p>I Indicates that the FORMAT INTERNAL option was specified during LOAD.</p> <p>When ICTYPE=A-A, A-R, B, C, P, R, S, W, or X, indicates that the page format was changed by the ALTER ADD PARTITION, ALTER ROTATE PARTITION, or CREATE statement, or by the LOAD REPLACE, REBUILD, REORG, or RECOVER utilities:</p> <p>B Indicates that the page format was created or converted to basic page format with 6-byte RBA or LRSN values</p> <p>E Indicates that the page format was created or converted to extended page format with 10-byte RBA or LRSN values.</p> <p>When ICTYPE=A and STYPE=A or R:</p> <p>B Indicates that the page format was converted to basic page format with 6-byte RBA or LRSN values.</p> <p>E Indicates that the page format was converted to extended page format with 10-byte RBA or LRSN values.</p>	
INSTANCE	SMALLINT NOT NULL WITH DEFAULT 1	<p>When STYPE = E and ICTYPE = A, INSTANCE indicates the data set instance number of a base object after an EXCHANGE statement completes. The value of the INSTANCE column for the last data exchange will match the value of the INSTANCE column for the SYSIBM.SYSTABLESPACE table.</p> <p>For an image copy, INSTANCE indicates the instance number of the current base objects (table and index).</p>	G
RELCREATED	CHAR(1) NOT NULL WITH DEFAULT	The Db2 release that created the object. Blank if created prior to DB2 9. For other values, see "Release dependency indicators" in Appendix H, "Db2 catalog tables," on page 2333.	G

Column name	Data type	Description	Use
MODECREATED	CHAR(2) NOT NULL WITH DEFAULT	The latest mode to which the Db2 subsystem had been migrated when the SYSCOPY record was written: C Conversion mode or CM* E Enabling-new-function mode or ENFM* N New-function mode blank Prior to Db2 11	G

SYSTXTTRUSTATTRS catalog table

The SYSTXTTRUSTATTRS table contains one row for each list of attributes for a given trusted context. The schema is SYSIBM.

Table 289. SYSIBM.SYSTXTTRUSTATTRS table column descriptions

Column name	Data type	Description	Use
CONTEXTID	INTEGER NOT NULL	The internal trusted context ID.	G
NAME	VARCHAR(128) NOT NULL	Name of the trust attribute. Possible values including the following attributes: <ul style="list-style-type: none"> An IPv4 address is represented as a dotted decimal IP address. An example of an IPv4 address is '9.112.46.111'. An IPv6 address is represented as a colon hexadecimal address. An example of an IPv6 address is '2001:0DB8:0000:0000:0008:0800:200C:417A', which can also be expressed in a compressed form as '2001:DB8::8:800:200C:417A'. A domain name which is converted to an IP address by the domain name server where a resulting IPv4 or IPv6 address is determined. A job or started task name for local applications. If the job name ends with *, any job name that matches the characters prior to * in the specified job name are considered for establishing the trusted connection. A network access security zone name in the RACF SERVAUTH class. 	G
VALUE	VARCHAR(254) NOT NULL	The value of the trust attribute.	G
CREATEDTS	TIMESTAMP NOT NULL	The time when the attribute is created.	G

Table 289. SYSIBM.SYSCTXTTRUSTATTRS table column descriptions (continued)

Column name	Data type	Description	Use
IBMREQD	CHAR(1) NOT NULL	A value of Y indicates that the row was provided with the Db2 product code. For all other values, see Release dependency indicators . The value in this field is not a reliable indicator of release dependencies.	G
SYS_START	TIMESTAMP(12) NOT NULL GENERATED ALWAYS AS ROW BEGIN	Reserved for future IBM use.The row-begin column of the SYSTEM_TIME period, for system-period data versioning.	G
SYS_END	TIMESTAMP(12) NOT NULL GENERATED ALWAYS AS ROW END	Reserved for future IBM use.The row-end column of the SYSTEM_TIME period, for system-period data versioning.	G
TRANS_START	TIMESTAMP(12) NOT NULL GENERATED ALWAYS AS TRANSACTION START ID	Reserved for future IBM use.	G

SYSDATABASE catalog table

The SYSDATABASE table contains one row for each database. The schema is SYSIBM.

Column name	Data type	Description	Use
NAME	VARCHAR(24) NOT NULL	Database name.	G
CREATOR	VARCHAR(128) NOT NULL	Authorization ID of the owner of the database.	G
STGROUP	VARCHAR(128) NOT NULL	Name of the default storage group of the database; blank for a system database.	G
BPOOL	CHAR(8) NOT NULL	Name of the default buffer pool of the table space; blank for a system table space.	G
DBID	SMALLINT NOT NULL	Internal identifier of the database. If there were 32511 databases or more when this database was created, the DBID is a negative number.	S
IBMREQD	CHAR(1) NOT NULL	A value of Y indicates that the row was provided with the Db2 product code. For all other values, see Release dependency indicators . The value in this field is not a reliable indicator of release dependencies. RELCREATED should be used instead.	G

Column name	Data type	Description	Use
CREATEDBY	VARCHAR(128) NOT NULL WITH DEFAULT	Primary authorization ID of the user who created the database.	G
ROSHARE	CHAR(1) NOT NULL WITH DEFAULT	Not used.	N
TIMESTAMP	TIMESTAMP NOT NULL WITH DEFAULT	Not used.	N
TYPE	CHAR(1) NOT NULL WITH DEFAULT	Type of database: blank Not a work file database or a TEMP database. T A TEMP file database. W A work file database. The database is DSNDB07, or it was created with the WORKFILE clause and used as a work file database by a member of a Db2 data sharing group.	G
GROUP_MEMBER	VARCHAR(24) NOT NULL WITH DEFAULT	The Db2 data sharing member name of the Db2 subsystem that uses this work file database. This column is blank if the work file database was not created in a Db2 data sharing environment, or if the database is not a work file database as indicated by the TYPE column.	G
CREATEDTS	TIMESTAMP NOT NULL WITH DEFAULT	Time when the CREATE statement was executed for the database. For DSNDB04 and DSNDB06, the value is '1985-04-01.00.00.00.000000'.	G
ALTEREDTS	TIMESTAMP NOT NULL WITH DEFAULT	Time when the most recent ALTER DATABASE statement was applied. If no ALTER DATABASE statement has been applied, ALTEREDTS has the value of CREATEDTS.	G
ENCODING_SCHEME	CHAR(1) NOT NULL WITH DEFAULT 'E'	Default encoding scheme for the database: E EBCDIC A ASCII U Unicode blank For DSNDB04, a work file database, and a TEMP database.	G

Column name	Data type	Description	Use
SBCS_CCSID	INTEGER NOT NULL WITH DEFAULT	Default SBCS CCSID for the database. For a TEMP database, a work file database, or a database created in a Db2 release prior to Version 5, the value is 0.	G
DBCS_CCSID	INTEGER NOT NULL WITH DEFAULT	Default DBCS CCSID for the database. If mixed data is not used and the CCSID for the database is defined as EBCDIC or ASCII, the default value is 0. For a TEMP database, a work file database, or a database created in a Db2 release prior to Version 5, the value is 0.	G
MIXED_CCSID	INTEGER NOT NULL WITH DEFAULT	Default mixed CCSID for the database. If mixed data is not used and the CCSID for the database is defined as EBCDIC or ASCII, the default value is 0. For a TEMP database, a work file database, or a database created in a Db2 release prior to Version 5, the value is 0.	G
INDEXBP	CHAR(8) NOT NULL WITH DEFAULT 'BPO'	Name of the default buffer pool for indexes.	G
IMPLICIT	CHAR(1) NOT NULL WITH DEFAULT 'N'	Indicates whether the database was implicitly created: Y The database was implicitly created N The database was explicitly created	G
CREATORTYPE	CHAR(1) NOT NULL WITH DEFAULT	Indicates the type of creator: blank Authorization ID L Role	G
RELCREATED	CHAR(1) NOT NULL	The release of Db2 that is used to create the object. See Release dependency indicators for the values.	G

SYSDATATYPES catalog table

The SYSDATATYPES table contains one row for each user-defined type defined to the system. The schema is SYSIBM.

Table 290. SYSIBM.SYSDATATYPES table column descriptions

Column name	Data type	Description	Use
SCHEMA	VARCHAR(128) NOT NULL	Schema of the data type.	G
OWNER	VARCHAR(128) NOT NULL	Owner of the data type.	G

Table 290. SYSIBM.SYSDATATYPES table column descriptions (continued)

Column name	Data type	Description	Use
NAME	VARCHAR(128) NOT NULL	Name of the data type.	G
CREATEDBY	VARCHAR(128) NOT NULL	Primary authorization ID of the user who created the data type.	G
SOURCESHEMA	VARCHAR(128) NOT NULL	Schema of the source data type.	G
SOURCETYPE	VARCHAR(128) NOT NULL	Name of the source type.	G
METATYPE	CHAR(1) NOT NULL	The class of data type: A User-defined ordinary array type L User-defined associative array type T Distinct type	G
DATATYPEID	INTEGER NOT NULL	Internal identifier of the data type.	S
SOURCETYPEID	INTEGER NOT NULL	Internal ID of the built-in data type on which the distinct type or array elements are based.	S
LENGTH	INTEGER NOT NULL	Maximum length or precision for a data type that is based on the IBM-defined DECIMAL data type. The data type can be a distinct type or an array type.	G
SCALE	SMALLINT NOT NULL	One of the following values: <ul style="list-style-type: none"> For a data type that is based on the IBM-defined DECIMAL data type, the scale. The data type can be a distinct type or an array type. Number of fractional second digits for a data type that is based on the IBM-defined timestamp or timestamp with time zone type. For a data type that is based on the IBM-defined TIMESTAMP or TIMESTAMP WITH TIME ZONE type, the number of fractional-second digits. For any other data type, the value is 0. If the value is a timestamp, the LENGTH is 10 and the SCALE is 0, the number of fractional second digits is 6.	G

Table 290. SYSIBM.SYSDATATYPES table column descriptions (continued)

Column name	Data type	Description	Use
SUBTYPE	CHAR(1) NOT NULL	<p>Subtype of the data type, if the source type is one of the character types. The data type can be a distinct type or an array type. Possible values are:</p> <p>B The subtype is FOR BIT DATA.</p> <p>S The subtype is FOR SBCS DATA.</p> <p>M The subtype is FOR MIXED DATA.</p> <p>blank The source type is not a character type.</p>	G
CREATEDTS	TIMESTAMP NOT NULL	Time when the data type was created.	G
ENCODING_SCHEME	CHAR(1) NOT NULL	<p>Encoding scheme of the data type:</p> <p>A ASCII</p> <p>E EBCDIC</p> <p>U Unicode</p>	G
IBMREQD	CHAR(1) NOT NULL	<p>A value of Y indicates that the row was provided with the Db2 product code. For all other values, see Release dependency indicators.</p> <p>The value in this field is not a reliable indicator of release dependencies. RELCREATED should be used instead.</p>	G
REMARKS	VARCHAR(762) NOT NULL	A character string provided by the user with the COMMENT statement.	G
OWNERTYPE	CHAR(1) NOT NULL WITH DEFAULT	<p>Indicates the type of owner:</p> <p>blank Authorization ID</p> <p>L Role</p>	G
RELCREATED	CHAR(1) NOT NULL	The release of Db2 that is used to create the object. See Release dependency indicators for the values.	G

Table 290. SYSIBM.SYSDATATYPES table column descriptions (continued)

Column name	Data type	Description	Use
INLINE_LENGTH	INTEGER NOT NULL WITH DEFAULT -1	The inline length attribute of the type if it is based on a LOB source type: -1 This type does not specify INLINE LENGTH greater than or equal to 0 The inline length attribute (in byte) of the type if it is based on a LOB source type	G
ARRAYLENGTH	BIGINT NOT NULL WITH DEFAULT	Maximum cardinality, if the data type is an ordinary array type. For all other data types, the value is 0.	G
ARRAYINDEXTYPEID	INTEGER NOT NULL WITH DEFAULT	Data type of the index, if the data types is an associative array type. For all other data types, the value is 0.	G
ARRAYINDEXTYPELEN	BIGINT NOT NULL WITH DEFAULT	Maximum length of the array index, if the data types is an associative array type. For all other data types, the value is 0.	G
ARRAYINDEXSUBTYPE	CHAR(1) NOT NULL WITH DEFAULT	Subtype of the array index: B The subtype is FOR BIT DATA. S The subtype is FOR SBCS DATA. M The subtype is FOR MIXED DATA. blank The array index is not a character type.	G

SYSDBAUTH catalog table

The SYSDBAUTH table records the privileges that are held by users over databases. The schema is SYSIBM.

Table 291. SYSIBM.SYSDBAUTH table column descriptions

Column name	Data type	Description	Use
GRANTOR	VARCHAR(128) NOT NULL	Authorization ID or role of the user who granted the privileges. Could also be PUBLIC.	G
GRANTEE	VARCHAR(128) NOT NULL	Application ID of the user who holds the privilege. Could also be PUBLIC for a grant to PUBLIC.	G
NAME	VARCHAR(24) NOT NULL	Database name.	G

Table 291. SYSIBM.SYSDBAUTH table column descriptions (continued)

Column name	Data type	Description	Use
—	CHAR(12) NOT NULL	Internal use only.	I
DATEGRANTED	CHAR(6) NOT NULL	Not used.	N
TIMEGRANTED	CHAR(8) NOT NULL	Not used.	N
GRANTEETYPE	CHAR(1) NOT NULL WITH DEFAULT	Indicates the type of grantee: blank Authorization ID L Role	G
AUTHHOWGOT	CHAR(1) NOT NULL	Authorization level of the user from whom the privileges were received. This authorization level is not necessarily the highest authorization level of the grantor. blank Not applicable C DBCTRL D DBADM E SECADM G ACCESSCTRL L SYSCTRL M DBMAINT S SYSADM	G
CREATETABAUTH	CHAR(1) NOT NULL	Whether the GRANTEE can create tables within the database: blank Privilege is not held G Privilege held with the GRANT option Y Privilege is held without the GRANT option	G

Table 291. SYSIBM.SYSDBAUTH table column descriptions (continued)

Column name	Data type	Description	Use
CREATETSAUTH	CHAR(1) NOT NULL	Whether the GRANTEE can create table spaces within the database: blank Privilege is not held G Privilege held with the GRANT option Y Privilege is held without the GRANT option	G
DBADMAUTH	CHAR(1) NOT NULL	Whether the GRANTEE has DBADM authority over the database: blank Privilege is not held G Privilege held with the GRANT option Y Privilege is held without the GRANT option	G
DBCTRLAUTH	CHAR(1) NOT NULL	Whether the GRANTEE has DBCTRL authority over the database: blank Privilege is not held G Privilege held with the GRANT option Y Privilege is held without the GRANT option	G
DBMAINTAUTH	CHAR(1) NOT NULL	Whether the GRANTEE has DBMAINT authority over the database: blank Privilege is not held G Privilege held with the GRANT option Y Privilege is held without the GRANT option	G
DISPLAYDBAUTH	CHAR(1) NOT NULL	Whether the GRANTEE can issue the DISPLAY command for the database: blank Privilege is not held G Privilege held with the GRANT option Y Privilege is held without the GRANT option	G

Table 291. SYSIBM.SYSDBAUTH table column descriptions (continued)

Column name	Data type	Description	Use
DROPAUTH	CHAR(1) NOT NULL	Whether the GRANTEE can issue the ALTER DATABASE and DROP DATABASE statement: blank Privilege is not held G Privilege held with the GRANT option Y Privilege is held without the GRANT option	G
IMAGCOPYAUTH	CHAR(1) NOT NULL	Whether the GRANTEE can use the COPY, MERGECOPY, MODIFY, and QUIESCE utilities on the database: blank Privilege is not held G Privilege held with the GRANT option Y Privilege is held without the GRANT option	G
LOADAUTH	CHAR(1) NOT NULL	Whether the GRANTEE can use the LOAD utility to load tables in the database: blank Privilege is not held G Privilege held with the GRANT option Y Privilege is held without the GRANT option	G
REORGAUTH	CHAR(1) NOT NULL	Whether the GRANTEE can use the REORG utility to reorganize table spaces and indexes in the database: blank Privilege is not held G Privilege held with the GRANT option Y Privilege is held without the GRANT option	G
RECOVERDBAUTH	CHAR(1) NOT NULL	Whether the GRANTEE can use the RECOVER and REPORT utilities on table spaces in the database: blank Privilege is not held G Privilege held with the GRANT option Y Privilege is held without the GRANT option	G

Table 291. SYSIBM.SYSDBAUTH table column descriptions (continued)

Column name	Data type	Description	Use
REPAIRAUTH	CHAR(1) NOT NULL	Whether the GRANTEE can use the DIAGNOSE and REPAIR utilities on table spaces and indexes in the database: blank Privilege is not held G Privilege held with the GRANT option Y Privilege is held without the GRANT option	G
STARTDBAUTH	CHAR(1) NOT NULL	Whether the GRANTEE can use the START command against the database: blank Privilege is not held G Privilege held with the GRANT option Y Privilege is held without the GRANT option	G
STATSAUTH	CHAR(1) NOT NULL	Whether the GRANTEE can use the CHECK and RUNSTATS utilities against the database: blank Privilege is not held G Privilege held with the GRANT option Y Privilege is held without the GRANT option	G
STOPAUTH	CHAR(1) NOT NULL	Whether the GRANTEE can issue the STOP command against the database: blank Privilege is not held G Privilege held with the GRANT option Y Privilege is held without the GRANT option	G
IBMREQD	CHAR(1) NOT NULL	A value of Y indicates that the row was provided with the Db2 product code. For all other values, see Release dependency indicators . The value in this field is not a reliable indicator of release dependencies.	G
GRANTEDTS	TIMESTAMP NOT NULL WITH DEFAULT	Time when the GRANT statement was executed.	G

Table 291. SYSIBM.SYSDBAUTH table column descriptions (continued)

Column name	Data type	Description	Use
GRANTORTYPE	CHAR(1) NOT NULL WITH DEFAULT	Indicates the type of grantor: blank Authorization ID L Role	G
SYS_START	TIMESTAMP(12) NOT NULL GENERATED ALWAYS AS ROW BEGIN	Reserved for future IBM use.The row-begin column of the SYSTEM_TIME period, for system-period data versioning.	G
SYS_END	TIMESTAMP(12) NOT NULL GENERATED ALWAYS AS ROW END	Reserved for future IBM use.The row-end column of the SYSTEM_TIME period, for system-period data versioning.	G
TRANS_START	TIMESTAMP(12) NOT NULL GENERATED ALWAYS AS TRANSACTION START ID	Reserved for future IBM use.	G

SYSDBRM catalog table

The SYSDBRM table contains one row for each DBRM of each application plan. The schema is SYSIBM.

Column name	Data type	Description	Use
NAME	VARCHAR(24) NOT NULL	Name of the DBRM.	G
TIMESTAMP	CHAR(8) NOT NULL FOR BIT DATA	Consistency token.	S
PDSNAME	VARCHAR(132) NOT NULL	Name of the partitioned data set of which the DBRM is a member.	G
PLNAME	VARCHAR(24) NOT NULL	Name of the application plan of which this DBRM is a part.	G
PLCREATOR	VARCHAR(128) NOT NULL	Authorization ID of the owner of the application plan.	G
PRECOMPTIME	CHAR(8) NOT NULL	Not used.	N
PRECOMPDATE	CHAR(6) NOT NULL	Not used.	N

Column name	Data type	Description	Use
QUOTE	CHAR(1) NOT NULL	SQL string delimiter for the SQL statements in the DBRM: N Apostrophe Y Quotation mark	G
COMMA	CHAR(1) NOT NULL	Decimal point representation for SQL statements in the DBRM: N Period Y Comma	G
HOSTLANG	CHAR(1) NOT NULL	The host language used: B Assembler language C OS/VS COBOL D C F Fortran P PL/I 2 VS COBOL II or IBM COBOL Release 1 (formerly called COBOL/370) 3 IBM COBOL (Release 2 or subsequent releases) 4 C++	G
IBMREQD	CHAR(1) NOT NULL	A value of Y indicates that the row was provided with the Db2 product code. For all other values, see Release dependency indicators . The value in this field is not a reliable indicator of release dependencies. RELCREATED should be used instead.	G
CHARSET	CHAR(1) NOT NULL WITH DEFAULT	Indicates whether the system CCSID for SBCS data was 290 (Katakana) when the program was precompiled: A No K Yes	G

Column name	Data type	Description	Use
MIXED	CHAR(1) NOT NULL WITH DEFAULT	Indicates if mixed data was in effect when the application program was precompiled (for more on when mixed data is in effect, see “Character strings” on page 102): N No Y Yes	G
DEC31	CHAR(1) NOT NULL WITH DEFAULT	Indicates whether DEC31 was in effect when the program was precompiled: blank No Y Yes For more information, see “Arithmetic operators in expressions” on page 250 .	G
VERSION	VARCHAR(122) NOT NULL WITH DEFAULT	Version identifier for the DBRM.	G
PRECOMPTS	TIMESTAMP NOT NULL WITH DEFAULT	Time when the DBRM was precompiled.	G
PLCREATOR TYPE	CHAR(1) NOT NULL WITH DEFAULT	Indicates the type of creator: blank Authorization ID L Role	G
RELCREATED	CHAR(1) NOT NULL	The release of Db2 that is used to create the object. See Release dependency indicators for the values.	G

SYSDEPENDENCIES catalog table

The SYSDEPENDENCIES table records the dependencies between objects. The schema is SYSIBM.

Table 292. SYSIBM.SYSDEPENDENCIES table column descriptions

Column name	Data type	Description	Use
BNAME	VARCHAR(128) NOT NULL	Name of the object on which another object is dependent. If BTYPE is F, the name is the specific name of the function. If BTYPE is W or Z, the name is the name of the table for which the period is defined.	G

Table 292. SYSIBM.SYSDEPENDENCIES table column descriptions (continued)

Column name	Data type	Description	Use
BSCHEMA	VARCHAR(128) NOT NULL	Schema or qualifier of the object on which another object is dependent.	G
BCOLNAME	VARCHAR(128) NOT NULL WITH DEFAULT	Column name of the object on which another object is dependent.	G
BCOLNO	SMALLINT NOT NULL WITH DEFAULT	Column number of the object on which another object is dependent.	G

Table 292. SYSIBM.SYSDEPENDENCIES table column descriptions (continued)

Column name	Data type	Description	Use
BTYPE	CHAR(1) NOT NULL	<p>The type of object that is identified by BNAME, BSCHEMA, and BCOLNAME:</p> <p>C Column</p> <p>E INSTEAD OF trigger</p> <p>F Function</p> <p>G Global temporary table</p> <p>H Global variable</p> <p>I Index</p> <p>M Materialized query table</p> <p>O Procedure</p> <p>P Partitioned table space</p> <p>Q Sequence</p> <p>R Table space</p> <p>S Synonym</p> <p>T Table</p> <p>U User-defined type, which is a distinct type or an array type.</p> <p>V View</p> <p>W SYSTEM_TIME period</p> <p>Z BUSINESS_TIME period</p> <p>0 (zero) Alias</p>	G
BOWNER	VARCHAR(128) NOT NULL WITH DEFAULT	Authorization ID of the owner of the object on which another object is dependent.	G

Table 292. SYSIBM.SYSDEPENDENCIES table column descriptions (continued)

Column name	Data type	Description	Use
BOWNERTYPE	CHAR(1) NOT NULL	Type of creator of the object on which another object is dependent: L Role blank Authorization ID that is not a role	G
DNAME	VARCHAR(128) NOT NULL	Name of the object that has dependencies on another object.	G
DSHEMA	VARCHAR(128) NOT NULL	Schema or qualifier of the object that has dependencies on another object.	G
DCOLNAME	VARCHAR(128) NOT NULL	Column name of the object that has dependencies on another object.	G
DCOLNO	SMALLINT NOT NULL WITH DEFAULT	Column number of the object that has dependencies on another object.	G
DTYPE	CHAR(1) NOT NULL	The type of the object that is identified by DSHEMA, DNAME, DCOLNAME, and DVERSION: B Trigger package for basic trigger C Generated column F Function I Index M Materialized query table O Procedure V View X Row permission Y Column mask 1 Trigger package for an advanced trigger	G
DOWNER	VARCHAR(128) NOT NULL	Authorization ID of the owner of the object that has dependencies on another object.	G

Table 292. SYSIBM.SYSDEPENDENCIES table column descriptions (continued)

Column name	Data type	Description	Use
DOWNERTYPE	CHAR(1) NOT NULL	Type of creator of the object that has dependencies on another object: L Role blank Authorization ID if not a role	G
IBMREQD	CHAR(1) NOT NULL	A value of Y indicates that the row was provided with the Db2 product code. For all other values, see Release dependency indicators . The value in this field is not a reliable indicator of release dependencies.	G
BAUTH	SMALLINT NOT NULL WITH DEFAULT	The privilege that is held on the object on which another object is dependent.	G
DVERSION	VARCHAR(122) NOT NULL WITH DEFAULT	The version identifier of the object that is identified by DSCHEMA and DNAME if the object has a version. This column contains a zero length string for the objects that are created prior to Version 10 and for the rows that correspond to objects without versions.	G

SYSDDUMMY1 catalog table

The SYSDDUMMY1 catalog table contains one row. It is used for SQL statements in which a table reference is required, but the contents of the table are not important. The schema is SYSIBM.

Unlike the other catalog tables, which reside in Unicode table spaces, SYSIBM.SYSDDUMMY1 resides in table space SYSEBCDC, which is an EBCDIC table space.

Table 293. SYSIBM.SYSDDUMMY1 table column descriptions

Column name	Data type	Description	Use
IBMREQD	CHAR(1) NOT NULL	A value of Y indicates that the row was provided with the Db2 product code. For all other values, see Release dependency indicators . The value in this field is not a reliable indicator of release dependencies.	G

SYSDDUMMYA catalog table

The SYSDDUMMYA table contains one row. It is used for SQL statements in which a table reference is required, but the contents of the table are not important. The schema is SYSIBM.

SYSIBM.SYSDDUMMYA resides in table space SYSTSASC, which is a ASCII table space.

Table 294. SYSIBM.SYSDUMMYA table column descriptions

Column name	Data type	Description	Use
IBMREQD	CHAR(1) NOT NULL	A value of Y indicates that the row was provided with the Db2 product code. For all other values, see Release dependency indicators . The value in this field is not a reliable indicator of release dependencies.	G

SYSDUMMYE catalog table

The SYSDUMMYE table contains one row. It is used for SQL statements in which a table reference is required, but the contents of the table are not important. The schema is SYSIBM.

SYSIBM.SYSDUMMYE resides in table space SYSEBCDC, which is a EBCDIC table space.

Table 295. SYSIBM.SYSDUMMYE table column descriptions

Column name	Data type	Description	Use
IBMREQD	CHAR(1) NOT NULL	A value of Y indicates that the row was provided with the Db2 product code. For all other values, see Release dependency indicators . The value in this field is not a reliable indicator of release dependencies.	G

SYSDUMMYU catalog table

The SYSDUMMYU table contains one row. It is used for SQL statements in which a table reference is required, but the contents of the table are not important. The schema is SYSIBM.

SYSIBM.SYSDUMMYU resides in table space SYSTSUNI, which is a Unicode table space.

Table 296. SYSIBM.SYSDUMMYU table column descriptions

Column name	Data type	Description	Use
IBMREQD	CHAR(1) NOT NULL	A value of Y indicates that the row was provided with the Db2 product code. For all other values, see Release dependency indicators . The value in this field is not a reliable indicator of release dependencies.	G

SYSDYNQRY catalog table

The SYSDYNQRY table contains information for the stabilization of access paths for dynamic SQL statements. The schema is SYSIBM.

Column name	Data type	Description	Use
SDQ_STMT_ID	BIGINT NOT NULL GENERATED BY DEFAULT AS IDENTITY	The identifier of the stabilized dynamic query.	

Column name	Data type	Description	Use
STBLGRP	VARCHAR(128) NOT NULL	The name of the stabilization group.	
COPYID	SMALLINT NOT NULL WITH DEFAULT	The copy type of the stabilized runtime structures for the query in this row: 0 The current copy. 4 An invalid copy.	
CURSQLID	VARCHAR (128) NOT NULL	The current SQLID for the stabilized dynamic query.	
CURSCHEMA	VARCHAR (128) NOT NULL	Current schema for stabilized dynamic query.	
CURAPPLCOMPAT	VARCHAR (10) NOT NULL	Current application compatibility for stabilized dynamic query.	
QUERY_HASH	CHAR(16) NOT NULL FOR BIT DATA	The hash key generated by the SQL statement text of the stabilized dynamic query.	
QUERY_HASH_VERSION	INTEGER NOT NULL	The version of the query hash.	
VALID	CHAR(1) NOT NULL	Whether the stabilized dynamic query is valid. 'A' An ALTER statement changed the description of the table or base table of a view referred to by the query. For a CREATE INDEX statement involving data sharing, VALID is also marked as 'A'. The changes do not invalidate the query. 'H' An ALTER TABLE statement changed the description of the table or base table of a view referred to by the query. For objects that were created in Db2 releases prior to Version 5, the change invalidates the query. 'N' The stabilized access path is not valid. 'Y' The stabilized access path for the dynamic query is valid.	
LASTUSED	DATE WITH DEFAULT	The date on which the query that uses the stabilized runtime structures was last run.	
RELBOUND	CHAR(1) NOT NULL	The Db2 release in which the query was stabilized. See Release dependency indicators .	
GROUP_MEMBER	VARCHAR(24) NOT NULL	The data sharing member name that updates the row.	

Column name	Data type	Description	Use
UPDATEDTS	TIMESTAMP NOT NULL	Timestamp when statement was stabilized.	
ROWID	ROWID NOT NULL GENERATED ALWAYS	Internal use only.	
STMTTEXT	CLOB (2M) NOT NULL	The text of the SQL statement and any attribute string.	
DATA1	BLOB(2G) INLINE LENGTH (32329)	Internal use only.	
DATA2	BLOB(2G) NOT NULL	Internal use only.	
DATA3	BLOB(2G) NOT NULL	Internal use only.	
DATA4	BLOB(2G) NOT NULL	Internal use only.	
DATA5	VARCHAR(128) NOT NULL	Internal use only.	
DATA6	CHAR(8) NOT NULL FOR BIT DATA	Internal use only.	
FUNCTION_LVL	VARCHAR(10)	The function level of the query.	G

Related concepts

[Dynamic SQL plan stability \(Db2 Performance\)](#)

Related tasks

[Stabilizing access paths for dynamic SQL statements \(Db2 Performance\)](#)

SYSDYNQRYDEP catalog table

The SYSDYNQRYDEP table contains information about dependencies for dynamic query packages. The schema is SYSIBM.

Access paths for SQL statements might depend on objects that Db2 does not actually use when it processes the selected access paths. Such dependencies are recorded in the SYSDYNQRYDEP catalog table, but they are not be shown in EXPLAIN output.

Column name	Data type	Description	Use
SDQ_STMT_ID	BIGINT NOT NULL	The identifier of the stabilized dynamic SQL statement.	G

Column name	Data type	Description	Use
COPYID	SMALLINT NOT NULL	<p>The copy type of the stabilized runtime structures for the query in this row:</p> <p>0 The current copy.</p> <p>1 The previous copy.</p> <p>2 The original copy.</p>	G
BQUALIFIER	VARCHAR(128) NOT NULL	<p>The value of the column depends on the type of object:</p> <ul style="list-style-type: none"> • If BNAME identifies a table space (BTYPE is 'R'), the value is the name of its database. • If BNAME identifies a table on which a period is defined (BTYPE is 'W' or 'Z'), the value is the qualifier of that table. • If BNAME identifies user-defined function, a cast function, a stored procedure, or a sequence (BTYPE is 'F', 'O', or 'Q'), the value is the schema name. • If BNAME identifies a role, the value is blank. • Otherwise, the value is the schema of BNAME. 	G
BNAME	VARCHAR(128) NOT NULL	The name of the object that the query depends on.	G

Column name	Data type	Description	Use
BTYPE	CHAR(1) NOT NULL	Type of object identified by BNAME and BQUALIFIER: ' E ' INSTEAD OF trigger ' F ' User-defined function or cast function ' G ' Global temporary table. ' I ' Index. ' M ' Materialized query table ' O ' Stored procedure ' P ' Partitioned table space if it is defined as LARGE or with the DSSIZE parameter ' Q ' Sequence object ' R ' Table space ' S ' Synonym ' T ' Table ' U ' Distinct type ' V ' View ' W ' SYSTEM_TIME period ' Z ' BUSINESS_TIME period ' 0 (zero) Alias	G
CLASS	CHAR(1) NOT NULL	' A ' Authorization dependency ' D ' Data Definition Language dependency	G

Column name	Data type	Description	Use
BAUTH	SMALLINT NOT NULL WITH DEFAULT	<p>The privilege that is held on the object on which the query depends. The privilege applies only when CLASS is 'A'.</p> <p>50 SELECTAUTH</p> <p>51 INSERTAUTH</p> <p>52 DELETEAUTH</p> <p>53 UDPATEAUTH</p> <p>64 EXECUTEAUTH</p> <p>263 USAGEAUTH</p> <p>291 READAUTH</p> <p>292 WRITEAUTH</p> <p>0 The column is not used. CLASS is 'D'.</p>	G
AUTHID_TYPE	CHAR(1) NOT NULL WITH DEFAULT	<p>The type of authorization indicated by AUTHID.</p> <p>" (blank) The value of CLASS is 'D', or the value of CLASS is 'A' and AUTHID contains the name of an authorization ID.</p> <p>'L' AUTHID contains the name of a role.</p>	G
AUTHID	VARCHAR(128) NOT NULL WITH DEFAULT	The owner of the privilege on the object on which the query is dependent, or a zero-length string if the value of CLASS is 'D'.	G
DBNAME	VARCHAR(128) NOT NULL WITH DEFAULT	If the value of SDBADMAUTH is 'Y', DBNAME contains the name of the database on which the user or role indicated by AUTHID holds DBADM authority. Otherwise the value is blank.	G

Column name	Data type	Description	Use
BADMINAUTH	CHAR(1) NOT NULL	The authority that allowed access to the object on which the query is dependent. The admin authority only applies when CLASS is 'A'. 'B' SDBADMAUTH 'D' DBADMAUTH 'G' ACCESSCTRLAUTH 'K' SQLADMAUTH 'L' SYSCTRLAUTH 'S' SYSADMAUTH 'T' DATAACCESSAUTH " Authority not held	G
PUBLICAUTH	CHAR(1) NOT NULL WITH DEFAULT	'Y' This privilege is held by PUBLIC by the user or role indicated in AUTHID. '' (blank) This privilege is not held by PUBLIC, or the value of CLASS is 'D'.	G
ALLOBJAUTH	CHAR(1) NOT NULL WITH DEFAULT	'Y' The privilege is held on all objects within the schema by the user or role indicated in AUTHID. '' (blank) This privilege is not held on all objects within the schema, or the value of CLASS is 'D'.	G
QUERYHASH	BINARY(16) WITH DEFAULT	The hash key of the statement text if the value of CLASS is 'D', otherwise hexadecimal zeros.	G
—	CLOB(2M) NOT NULL WITH DEFAULT	Internal use only.	I
—	CHAR(8) NOT NULL FOR BIT DATA	Internal use only.	I

Related concepts

[Dynamic SQL plan stability \(Db2 Performance\)](#)

Related tasks

[Stabilizing access paths for dynamic SQL statements \(Db2 Performance\)](#)

Related reference

[SYSPACKDEP catalog table](#)

The SYSPACKDEP table records the dependencies of packages on local tables, views, synonyms, table spaces, indexes, aliases, functions, and stored procedures. The schema is SYSIBM.

SYSDYNQRY_EXPL catalog table

The SYSDYNQRY_EXPL catalog table contains internal use information for stabilized dynamic queries. The schema is SYSIBM.

Table 297. SYSIBM.SYSDYNQRY_EXPL table column descriptions

Column name	Data type	Description	Use
DATA2	BLOB(2G) NOT NULL WITH	Internal use only.	I

SYSDYNQRY_OPL catalog table

The SYSDYNQRY_OPL catalog table contains internal use information for stabilized dynamic queries. The schema is SYSIBM.

Table 298. SYSIBM.SYSDYNQRY_EPXL table column descriptions

Column name	Data type	Description	Use
DATA4	BLOB(2G) NOT NULL WITH	Internal use only.	I

SYSDYNQRY_SHTEL catalog table

The SYSDYNQRY_SHTEL table contains internal use information for stabilized dynamic queries. The schema is SYSIBM.

Table 299. SYSIBM.SYSDYNQRY_EPXL table column descriptions

Column name	Data type	Description	Use
DATA3	BLOB(2G) NOT NULL	Internal use only.	I

SYSDYNQRY_SPAL catalog table

The SYSDYNQRY_SPAL catalog table contains internal use information for stabilized dynamic queries. The schema is SYSIBM.

Table 300. SYSIBM.SYSDYNQRY_SPA table column descriptions

Column name	Data type	Description	Use
DATA1	BLOB(2G) NOT NULL WITH	Internal use only.	I

SYSDYNQRY_TXTL catalog table

The SYSDYNQRY_TXTL catalog table contains internal use information for stabilized dynamic queries. The schema is SYSIBM.

Table 301. SYSIBM.SYSDYNQRY_TEXTL table column descriptions

Column name	Data type	Description	Use
STMTTEXT	CLOB(2M) NOT NULL	Text of the SQL statement	I

SYSENVIRONMENT catalog table

The SYSENVIRONMENT table records the environment variables when an object is created. The schema is SYSIBM.

Table 302. SYSIBM.SYSENVIRONMENT table column descriptions

Column name	Data type	Description	Use
ENVID	INTEGER NOT NULL	Internal identifier of the environment.	G
CURRENT_SCHEMA	VARCHAR(128) NOT NULL	The current schema.	G
RELCREATED	CHAR(1) NOT NULL	The release when the environment information is created. See Release dependency indicators for values.	G
PATHSCHEMAS	VARCHAR(2048) NOT NULL	The schema path.	G
APPLICATION_ENCODING_CCSID	INTEGER NOT NULL	The CCSID of the application environment.	G
ORIGINAL_ENCODING_CCSID	INTEGER NOT NULL	The original CCSID of the statement text string.	G
DECIMAL_POINT	CHAR(1) NOT NULL	The decimal point indicator: C Comma P Period	G
MIN_DIVIDE_SCALE	CHAR(1) NOT NULL	The minimum divide scale: N The usual rules apply for decimal division in SQL Y Retain at least three digits to the right of the decimal point after any decimal division.	G
STRING_DELIMITER	CHAR(1) NOT NULL	The string delimiter that is used in COBOL string constants: A Apostrophe (') Q Quote (")	G
SQL_STRING_DELIMITER	CHAR(1) NOT NULL	The SQL string delimiter that is used in string constants: A Apostrophe (') Q Quote (")	G

Table 302. SYSIBM.SYSENVIRONMENT table column descriptions (continued)

Column name	Data type	Description	Use
MIXED_DATA	CHAR(1) NOT NULL	Uses mixed DBCS data: N No mixed data Y Mixed data	G
DECIMAL_ ARITHMETIC	CHAR(1) NOT NULL	The rules that are to be used for CURRENT PRECISION and when both operands in a decimal operation have a precision of 15 or less: 1 DEC15 specifies that the rules do not allow a precision greater than 15 digits 2 DEC31 specifies that the rules allow a precision of up to 31 digits	G
DATE_FORMAT	CHAR(1) NOT NULL	The date format: I ISO - yyyy-mm-dd J JIS - yyyy-mm-dd U USA - mm/dd/yyyy E EUR - dd.mm.yyyy L Locally defined by an installation exit routine	G
TIME_FORMAT	CHAR(1) NOT NULL	The time format: I ISO - hh.mm.ss J JIS - hh.mm.ss U USA - hh:mm AM or hh:mm PM E EUR - hh.mm.ss L Locally defined by an installation exit routine	G
FLOAT_FORMAT	CHAR(1) NOT NULL	The floating point format: I IEEE floating point format S System/390 floating point format	G

Table 302. SYSIBM.SYSENVIRONMENT table column descriptions (continued)

Column name	Data type	Description	Use
HOST_LANGUAGE	CHAR(8) NOT NULL	The host language: <ul style="list-style-type: none"> • ASM • C • CPP • IBMCOB • JAVA • PLI • FORTRAN 	G
CHARSET	CHAR(1) NOT NULL	The character set: A Alphanumeric	G
FOLD	CHAR(1) NOT NULL	FOLD is only applicable when HOST_LANGUAGE is C or CPP. Otherwise FOLD is blank. N Lower case letters in SBCS ordinary identifiers are not folded to uppercase Y Lower case letters in SBCS ordinary identifiers are folded to uppercase blank Not applicable	G
IBMREQD	CHAR(1) NOT NULL	A value of Y indicates that the row was provided with the Db2 product code. For all other values, see Release dependency indicators . The value in this field is not a reliable indicator of release dependencies.	G
ROUNDING	CHAR(1) NOT NULL WITH DEFAULT	The rounding mode that is used when arithmetic and casting operations are performed on DECFLOAT data: C ROUND_CEILING D ROUND_DOWN F ROUND_FLOOR G ROUND_HALF_DOWN E ROUND_HALF_EVEN H ROUND_HALF_UP U ROUND_UP	G

Table 302. SYSIBM.SYSENVIRONMENT table column descriptions (continued)

Column name	Data type	Description	Use
CREATEDTS	TIMESTAMP(12) NOT NULL	The time when the row was inserted.	G
APPLCOMPAT	VARCHAR(10) NOT NULL WITH DEFAULT	<p>The application compatibility level that is associated with this environment.</p> <p>VvvRrMmmm</p> <p>Compatibility with the behavior of the identified Db2 function level. For example, V12R1M510 specifies compatibility with the highest available Db2 12 function level. The equivalent function level or higher must be activated.</p> <p>For the new capabilities that become available in each application compatibility level, see:</p> <ul style="list-style-type: none"> • SQL changes in Db2 13 application compatibility levels • SQL changes in Db2 12 application compatibility levels <p>Tip: Extra program preparation steps might be required to increase the application compatibility level for applications that use data server clients or drivers to access Db2 for z/OS. For more information, see Setting application compatibility levels for data server clients and drivers (Db2 Application programming and SQL).</p> <p>V12R1</p> <p>Compatibility with the behavior of Db2 12 function level 500. This value has the same result as specifying V12R1M500.</p> <p>V11R1</p> <p>Compatibility with the behavior of Db2 11 new-function mode. After migration to Db2 12, this value has the same result as specifying V12R1M100. For more information, see V11R1 application compatibility level (Db2 Application programming and SQL)</p> <p>V10R1</p> <p>Compatibility with the behavior of DB2 10 new-function mode. For more information, see V10R1 application compatibility level (Db2 Application programming and SQL).</p>	G

SYSFIELDS catalog table

The SYSFIELDS table contains one row for every column that has a field procedure. The schema is SYSIBM.

Table 303. SYSIBM.SYSFIELDS table column descriptions

Column name	Data type	Description	Use
TBCREATOR	VARCHAR(128) NOT NULL	Schema or qualifier of the table that contains the column.	G
TBNAME	VARCHAR(128) NOT NULL	Name of the table that contains the column.	G
COLNO	SMALLINT NOT NULL	Numeric place of this column in the table.	G
NAME	VARCHAR(128) NOT NULL	Name of the column.	G
FLDTYPE	VARCHAR(24) NOT NULL	Data type of the encoded values in the field (This column might contain statistical values from a prior release.): INTEGER Large integer SMALLINT Small integer FLOAT Floating-point CHAR Fixed-length character string VARCHAR Varying-length character string DECIMAL Decimal GRAPHIC Fixed-length graphic string VARG Varying-length graphic string	G

Table 303. SYSIBM.SYSFIELDS table column descriptions (continued)

Column name	Data type	Description	Use
LENGTH	SMALLINT NOT NULL	The length attribute of the field; or, for a decimal field, its precision.(This column might contain statistical values from a prior release.) The number does not include the internal prefixes that can be used to record actual length and null state. INTEGER 4 SMALLINT 2 FLOAT 8 CHAR Length of string VARCHAR Maximum length of string DECIMAL Precision of number GRAPHIC Number of DBCS characters VARG Maximum number of DBCS characters	G
SCALE	SMALLINT NOT NULL	Scale if FLDTYPE is DECIMAL; otherwise, the value is 0.	G
FLDPROC	VARCHAR(24) NOT NULL	For a row describing a field procedure, the name of the procedure. (This column might contain statistical values from a prior release.)	G
WORKAREA	SMALLINT NOT NULL	For a row describing a field procedure, the size, in bytes, of the work area required for the encoding and decoding of the procedure. (This column might contain statistical values from a prior release.)	G
IBMREQD	CHAR(1) NOT NULL	A value of Y indicates that the row was provided with the Db2 product code. For all other values, see Release dependency indicators . The value in this field is not a reliable indicator of release dependencies.	G
EXITPARML	SMALLINT NOT NULL	For a row describing a field procedure, the length of the field procedure parameter value block. (This column might contain statistical values from a prior release.)	G
PARMLIST	VARCHAR(735) NOT NULL	For a row describing a field procedure, the parameter list following FLDPROC in the statement that created the column, with insignificant blanks removed. (This column might contain statistical values from a prior release.)	G

Table 303. SYSIBM.SYSFIELDS table column descriptions (continued)

Column name	Data type	Description	Use
EXITPARM	VARCHAR(1530) NOT NULL FOR BIT DATA	For a row describing a field procedure, the parameter value block of the field procedure (the control block passed to the field procedure when it is invoked). (This column might contain statistical values from a prior release.)	G

SYSFOREIGNKEYS catalog table

The SYSFOREIGNKEYS table contains one row for every column of every foreign key. The schema is SYSIBM.

Table 304. SYSIBM.SYSFOREIGNKEYS table column descriptions

Column name	Data type	Description	Use
CREATOR	VARCHAR(128) NOT NULL	Schema or qualifier of the table that contains the column.	G
TBNAME	VARCHAR(128) NOT NULL	Name of the table that contains the column.	G
RELNAME	VARCHAR(128) NOT NULL	Constraint name for the constraint for which the column is part of the foreign key.	G
COLNAME	VARCHAR(128) NOT NULL	Name of the column.	G
COLNO	SMALLINT NOT NULL	Numeric place of the column in its table.	G
COLSEQ	SMALLINT NOT NULL	Numeric place of the column in the foreign key.	G
IBMREQD	CHAR(1) NOT NULL	A value of Y indicates that the row was provided with the Db2 product code. For all other values, see Release dependency indicators . The value in this field is not a reliable indicator of release dependencies.	G

SYSINDEXCLEANUP catalog table

The rows in the SYSIBM.SYSINDEXCLEANUP table specify time windows to control index cleanup processing. Each row specifies a time window to enable or disable the cleanup of pseudo-deleted index entries for specific database objects. The schema is SYSIBM.

Table 305. SYSIBM.SYSINDEXCLEANUP table column descriptions

Column name	Data type	Description	Use
DBNAME	VARCHAR(24)	The name of the database that contains the index space.	G
INDEXSPACE	VARCHAR(24)	The name of the index space.	G

Table 305. SYSIBM.SYSINDEXCLEANUP table column descriptions (continued)

Column name	Data type	Description	Use
ENABLE_DISABLE	CHAR(1) NOT NULL	Specifies whether the row enables or disables cleanup for the specified index space. 'E' Enabled 'D' Disabled	G
MONTH_WEEK	CHAR(1) NOT NULL	Indicates the meaning of the value of the DAY column: 'M' The value indicates the day of the month. 'W' The value indicates a day of the week.	G
MONTH	SMALLINT	The month in which the time window applies. For example a 1 value indicates January and a 12 value indicates December. If this column contains NULL, the time window applies to all months. If the value of the MONTH_WEEK column is 'W', this value must be NULL.	G
DAY	SMALLINT	The day of the month or the day of the week for which the time window applies, as specified by the value of the MONTH_WEEK column. For example, if MONTH_WEEK='W', a 1 value indicates Monday and 7 indicates Sunday. If the value of this column is NULL, the time window applies to every day of the month or every day of the week.	G
START_TIME	TIME	The local time at the beginning of the time window specified by the row. When this column contains a null value, the row applies at all times on the specified days. This column must contain NULL if the END_TIME column contains NULL.	G
END_TIME	TIME	The local time at the end of the time window specified by the row. When this column contains a null value, the row applies at all times on the specified days. This column must contain NULL if the START_TIME column contains NULL.	G

Related tasks

[Controlling index cleanup processing \(Db2 Performance\)](#)

Related reference

[INDEX CLEANUP THREADS field \(INDEX_CLEANUP_THREADS subsystem parameter\) \(Db2 Installation and Migration\)](#)

SYSINDEXCONTROL catalog table

The SYSINDEXCONTROL table contains rows that specify time windows to control the use of memory allocated for an index. Each row specifies a time window for enabling or disabling the use of memory for a specific index object. The schema is SYSIBM.

Tip: Fast index traversal is intended to be automatically controlled by Db2. Use the SYSIBM.SYSINDEXCONTROL catalog table only to define exceptions, when the automatic processing is unacceptable. Index performance optimization might be impeded if the number of rows in this catalog table becomes too large.

Table 306. SYSIBM.SYSINDEXCONTROL table column descriptions

Column name	Data type	Description	Use
SSID	CHAR(4)	The name of a Db2 subsystem. In data sharing, if this column is NULL, this row applies to all members of the data sharing group.	G
PARTITION	SMALLINT	Partition number. If this column is NULL, then the action is applicable to all partitions of the specified index.	G
IXNAME	VARCHAR(128) NOT NULL	The name of the index.	G
IXCREATOR	VARCHAR(128) NOT NULL	The schema of the index.	G
TYPE	CHAR(1) NOT NULL WITH DEFAULT 'F'	The purpose for which memory is being used: F A structure for fast index traversal (FTB)	G
ACTION	CHAR(1) NOT NULL WITH DEFAULT 'A'	The action that is being performed: A The index is candidate for FTB creation when the INDEX_MEMORY_CONTROL subsystem parameter setting is (SELECTED,n) D Disable FTB creation F Force FTB creation	G
MONTH_WEEK	CHAR(1)	The meaning of the value in the DAY column. M A day of the month W A day of the week	G
MONTH	SMALLINT	Month during which the time window applies. Valid values are 1 (January) to 12 (December), or NULL. If this column contains NULL, the time window applies to all months. If MONTH_WEEK is 'W', this column value must be NULL.	G

Table 306. SYSIBM.SYSINDEXCONTROL table column descriptions (continued)

Column name	Data type	Description	Use
DAY	SMALLINT	Day of the month or day of the week for which the time window applies. <ul style="list-style-type: none"> • If MONTH_WEEK='M', valid values are 1 (first day of the month) to the number of the last day of the month, or NULL. • If MONTH_WEEK='W', valid values are 1 (Monday) to 7 (Sunday), or NULL. If this column contains NULL, the time window applies to every day of the month, or to every day of the week, depending on the value of the MONTH_WEEK column.	G
FROM_TIME	TIME	The time of day at which the time window begins. If this column contains NULL, no limitation on the time exists. This column contains NULL if the TO_TIME column contains NULL.	G
TO_TIME	TIME	The time of day at which the time window ends. If this column contains NULL, no limitation on the time exists. This column contains NULL if the FROM_TIME column contains NULL.	G

Related concepts

[Fast index traversal \(Db2 Performance\)](#)

Related tasks

[Enabling or disabling fast index traversal at the index level \(Db2 Performance\)](#)

Related reference

[INDEX MEMORY CONTROL field \(INDEX_MEMORY_CONTROL subsystem parameter\) \(Db2 Installation and Migration\)](#)

SYSINDEXES catalog table

The SYSINDEXES table contains one row for every index. The schema is SYSIBM.

Table 307. SYSIBM.SYSINDEXES table column descriptions

Column name	Data type	Description	Use
NAME	VARCHAR(128) NOT NULL	Name of the index.	G
CREATOR	VARCHAR(128) NOT NULL	The schema of the index.	G
TBNAME	VARCHAR(128) NOT NULL	Name of the table on which the index is defined.	G
TBCREATOR	VARCHAR(128) NOT NULL	The schema of the table.	G

Table 307. SYSIBM.SYSINDEXES table column descriptions (continued)

Column name	Data type	Description	Use
UNIQUERULE	CHAR(1) NOT NULL	<p>Whether the index is unique:</p> <p>C Yes, and it is used to enforce the uniqueness of a UNIQUE constraint or hash key columns.</p> <p>D No (duplicates are allowed)</p> <p>U Yes</p> <p>P Yes, and it is a primary index (As in prior releases of Db2, a value of P is used for primary keys that are used to enforce a referential constraint.)</p> <p>N Yes, and it is defined with UNIQUE WHERE NOT NULL</p> <p>R Yes, and it is an index used to enforce the uniqueness of a non-primary parent key</p> <p>G Yes, and it is an index used to enforce the uniqueness of values in a column defined as ROWID GENERATED BY DEFAULT</p> <p>X Yes, and it is an index used to enforce the uniqueness of values in a column that is used to identify or find XML values associated with a specific row.</p>	G
COLCOUNT	SMALLINT NOT NULL	The number of columns in the key.	G
CLUSTERING	CHAR(1) NOT NULL	<p>Whether CLUSTER was specified for the index:</p> <p>N No</p> <p>Y Yes</p>	G

Table 307. SYSIBM.SYSINDEXES table column descriptions (continued)

Column name	Data type	Description	Use
CLUSTERED	CHAR(1) NOT NULL	Whether the table is actually clustered by the index: N A significant number of rows are not in clustering order, or statistics have not been gathered. Y Most of the rows are in clustering order. blank Not applicable. This is an updatable column that can also be changed by the RUNSTATS utility. For a sparse index, the statistic is based on the actual contents of the index.	G
DBID	SMALLINT NOT NULL	Internal identifier of the database.	S
OBID	SMALLINT NOT NULL	Internal identifier of the index fan set descriptor.	S
ISOBID	SMALLINT NOT NULL	Internal identifier of the index page set descriptor.	S
DBNAME	VARCHAR(24) NOT NULL	Name of the database that contains the index.	G
INDEXSPACE	VARCHAR(24) NOT NULL	Name of the index space.	G
FIRSTKEYCARD	INTEGER NOT NULL	Not used	N
FULLKEYCARD	INTEGER NOT NULL	Not used	N
NLEAF	INTEGER NOT NULL	Number of active leaf pages in the index. The value is -1 if statistics have not been gathered. This is an updatable column.	S
NLEVELS	SMALLINT NOT NULL	Number of levels in the index tree. If the index is partitioned, it is the maximum of the number of levels in the index tree for all the partitions. The value is -1 if statistics have not been gathered. This is an updatable column.	S
BPOOL	CHAR(8) NOT NULL	Name of the buffer pool used for the index.	G

Table 307. SYSIBM.SYSINDEXES table column descriptions (continued)

Column name	Data type	Description	Use
PGSIZE	SMALLINT NOT NULL	Contains the value 4, 8, 16, or 32 which indicates the size, in KB, of the leaf pages in the index. If the index was created prior to DB2 9, the value will be 4096 for a 4 KB page size.	G
ERASERULE	CHAR(1) NOT NULL	Whether the data sets are erased when dropped. The value is meaningless if the index is partitioned: N No Y Yes	G
DSETPASS	VARCHAR(24) NOT NULL	Not used	N
CLOSERULE	CHAR(1) NOT NULL	Whether the data sets are candidates for closure when the limit on the number of open data sets is reached: N No Y Yes	G
SPACE	INTEGER NOT NULL	Number of kilobytes of DASD storage allocated to the index, as determined by the last execution of the STOSPACE utility. The value is 0 if the index is not related to a storage group, or if STOSPACE has not been run. If the index space is partitioned, the value is the total kilobytes of DASD storage allocated to all partitions that are defined in a storage group.	G
IBMREQD	CHAR(1) NOT NULL	A value of Y indicates that the row was provided with the Db2 product code. For all other values, see Release dependency indicators . The value in this field is not a reliable indicator of release dependencies. RELCREATED should be used instead.	G
CLUSTERRATIO	SMALLINT NOT NULL WITH DEFAULT	Percentage of rows that are in clustering order. For a partitioning index, it is the weighted average of all index partitions in terms of the number of rows in the partition. The value is 0 if statistics have not been gathered. The value is -2 if the index is for an auxiliary table. This is an updatable column. For a sparse index, the statistic is based on the actual contents of the index.	S
CREATEDBY	VARCHAR(128) NOT NULL WITH DEFAULT	Primary authorization ID of the user who created the index.	G

Table 307. SYSIBM.SYSINDEXES table column descriptions (continued)

Column name	Data type	Description	Use
IOFACTOR	SMALLINT NOT NULL	Internal use only.	I
PREFETCHFACTOR	SMALLINT NOT NULL	Not used	N
STATSTIME	TIMESTAMP NOT NULL WITH DEFAULT	If RUNSTATS or another utility with inline statistics updated the statistics, the date and time when the last utility invocation updated the statistics. The default value is '0001-01-01-00.00.00.000000'. The default value indicates that statistics were not collected. This column can be updated.	G
INDEXTYPE	CHAR(1) NOT NULL WITH DEFAULT	The index type: 2 Type 2 index or a hash overflow index on non-partitioned tables. blank Type 1 index D Data-partitioned secondary index P An index that is both partitioned and is a partitioning index (index that is on a table that uses table-controlled partitioning).	G
FIRSTKEYCARDF	FLOAT NOT NULL WITH DEFAULT -1	Number of distinct values of the first key column. This number is an estimate if updated while collecting statistics on a single partition. The value is -1 if statistics have not been gathered. This is an updatable column. For a sparse index, the statistic is based on the actual contents of the index.	S
FULLKEYCARDF	FLOAT NOT NULL WITH DEFAULT -1	Number of distinct values of the key. The value is -1 if statistics have not been gathered. This is an updatable column. For a sparse index, the statistic is based on the actual contents of the index.	S
CREATEDTS	TIMESTAMP NOT NULL WITH DEFAULT	Time when the CREATE statement was executed for the index. If the index was created in a Db2 release prior to Version 5, the value is '0001-01-01.00.00.00.000000'.	G
ALTEREDTS	TIMESTAMP NOT NULL WITH DEFAULT	Time when the most recent ALTER INDEX statement was executed for the index. If no ALTER INDEX statement has been applied, ALTEREDTS has the value of CREATEDTS. If the index was created in a Db2 release prior to Version 5, the value is '0001-01-01.00.00.00.000000'.	G

Table 307. SYSIBM.SYSINDEXES table column descriptions (continued)

Column name	Data type	Description	Use
PIECESIZE	INTEGER NOT NULL WITH DEFAULT	Maximum size of a data set in kilobytes for non-partitioned indexes. A value of zero (0) indicates that the index is a partitioned index or that the index was created in a Db2 release prior to Version 5.	G
COPY	CHAR(1) NOT NULL WITH DEFAULT 'N'	Whether COPY YES was specified for the index, which indicates if the index can be copied and if SYSIBM.SYSLGRNX recording is enabled for the index. N No Y Yes	G
COPYLRSN	CHAR(10) NOT NULL WITH DEFAULT X'00000000000000 00000000' FOR BIT DATA	The value can be either an RBA or LRSN. (LRSN is only for data sharing.) If the index is currently defined as COPY YES, the value is the RBA or LRSN when the index was created with COPY YES or altered to COPY YES, not the current RBA or LRSN. If the index is currently defined as COPY NO, the value is set to X'00000000000000000000' if the index was created with COPY NO; otherwise, if the index was altered to COPY NO, the value in COPYLRSN is not changed when the index is altered to COPY NO.	G
CLUSTERRATIOF	FLOAT NOT NULL WITH DEFAULT	When multiplied by 100, the value of the column is the percentage of rows that are in clustering order. For example, a value of '.9125' indicates 91.25%. For a partitioning index, it is the weighted average of all index partitions in terms of the number of rows in the partition. The value is 0 if statistics have not been gathered. The value is -2 if the index is for an auxiliary table, a node ID index or an XML index. This is an updatable column. For a sparse index, the statistic is based on the actual contents of the index.	G
SPACEF	FLOAT(8) NOT NULL WITH DEFAULT -1	Kilobytes of DASD storage. The value is -1 if statistics have not been gathered. This is an updatable column.	G
REMARKS	VARCHAR(762) NOT NULL WITH DEFAULT	A character field string provided by the user with the COMMENT statement.	G

Table 307. SYSIBM.SYSINDEXES table column descriptions (continued)

Column name	Data type	Description	Use
PADDED	CHAR(1) NOT NULL WITH DEFAULT	Indicates whether keys within the index are padded for varying-length column data: Y The index contains varying-length character or graphic data and is PADDED (the varying-length columns are padded to their maximum length). N The index contains varying-length character or graphic data and is NOT PADDED (the varying-length columns are not padded to their maximum length). Index-only access to all column data is possible. blank The index does not contain varying-length character or graphic data, or the index was created or altered prior to DB2 version 8.	G
VERSION	SMALLINT NOT NULL WITH DEFAULT	The version of the data row format for this index. A value of zero indicates that a version-creating alter has never occurred against this index.	G
OLDEST_VERSION	SMALLINT NOT NULL WITH DEFAULT	The version number describing the oldest format of data in the index space and any image copies of the index.	G
CURRENT_VERSION	SMALLINT NOT NULL WITH DEFAULT	The version number describing the newest format of data in the index space. A zero indicates that the index space has never had been versioned. After the version number reaches the maximum value, the number will wrap back to one.	G
RELCREATED	CHAR(1) NOT NULL WITH DEFAULT	Release of Db2 that was used to create the object, blank for indexes created before Version 8. For all other values, see Release dependency indicators .	G
AVGKEYLEN	INTEGER NOT NULL WITH DEFAULT -1	Average length of keys within the index. The value is -1 if statistics have not been gathered. For a sparse index, the statistic is based on the actual contents of the index.	G
KEYTARGET_COUNT	SMALLINT NOT NULL WITH DEFAULT	The number of key-targets for an extended index. The value is 0 for a simple index.	G
UNIQUE_COUNT	SMALLINT NOT NULL WITH DEFAULT	The number of columns or key-targets that make up the unique constraint of an index, when other non-constraint enforcing columns or key-targets exist. Otherwise the value is 0.	G

Table 307. SYSIBM.SYSINDEXES table column descriptions (continued)

Column name	Data type	Description	Use
IX_EXTENSION_T E	CHAR(1) NOT NULL WITH DEFAULT	Identifies the type of extended index: N Node ID index S Index on a scalar expression T Spatial index V XML index blank Simple index	G
COMPRESS	CHAR(1) NOT NULL WITH DEFAULT ' N'	Indicates whether index compression is active: N Index compression is not active Y Index compression is active	G
OWNER	VARCHAR(128) NOT NULL WITH DEFAULT	Authorization ID of the owner of the index. The value is an empty string for indexes created in a Db2 release prior to DB2 9.	G
OWNERTYPE	CHAR(1) NOT NULL WITH DEFAULT	Indicates the type of owner: blank Authorization ID L Role	G
DATAREPEATFA CTOR F	FLOAT NOT NULL WITH DEFAULT -1	The anticipated number of data pages that will be touched following an index key order. This number is -1 if statistics have not been collected. This is an updatable column. For a sparse index, the statistic is based on the actual contents of the index.	G
ENVID	INTEGER NOT NULL WITH DEFAULT	Internal environment identifier.	G
ROWID	ROWID NOT NULL GENERATED ALWAYS	ROWID column, created for the lob columns in this table.	G

Table 307. SYSIBM.SYSINDEXES table column descriptions (continued)

Column name	Data type	Description	Use
HASH	CHAR(1) NOT NULL WITH DEFAULT N	Whether the index is the hash overflow index for a hash table. N No. N is the default. Y Yes	G
SPARSE	CHAR(1) NOT NULL WITH DEFAULT N	Whether the index is sparse or not. N No. N is the default. Every data row has an index entry. Y Yes. This index might not have an entry for each data row in the table. X Excluded. This index will not have an index entry when every data row for a key column contains the NULL value.	G
PARSETREE	BLOB(1G) NOT NULL WITH DEFAULT	Internal use only.	I
RTSECTION	BLOB(1G) NOT NULL WITH DEFAULT	Internal use only.	I
DSSIZE	INTEGER WITH DEFAULT NULL	The maximum size in KB of a partitioned index data set for a table space with relative page numbers. 0 for nonpartitioned indexes or partitioned indexes for table spaces with absolute page numbers. NULL for indexes that were created before Db2 12.	G
PAGENUM	CHAR(1) NOT NULL WITH DEFAULT 'A'	Format of page numbers for the index, indicating absolute or relative page numbering. A Indicates absolute addressing. The page number is an absolute number from the first page of the index. If the index is partitioned, the partition number is embedded in the page number. R Indicates relative addressing for partitioned indexes. The page number is relative to the start of the partition. NULL for objects that were created before Db2 12	G
PARTKEYCOLNUM	SMALLINT NOT NULL WITH DEFAULT	Reserved for future IBM use.	I

Table 307. SYSIBM.SYSINDEXES table column descriptions (continued)

Column name	Data type	Description	Use
STATUS	CHAR(1) NOT NULL WITH DEFAULT	Reserved for future IBM use.	I
INDEXSTATUS	VARCHAR(30) NOT NULL WITH DEFAULT	Reserved for future IBM use.	I
PARTITIONS	SMALLINT	Reserved for future IBM use.	I
PQTY	INTEGER WITH DEFAULT NULL	<p>For user-managed data sets, the value is the primary space allocation in units of 4 KB storage blocks or -1.</p> <p>PQTY is based on a value of PRIQTY in the appropriate CREATE or ALTER TABLESPACE statement. Unlike PQTY, however, PRIQTY accepts space in 1 KB units.</p> <p>A value of -1 indicates that one of the following cases is true:</p> <ul style="list-style-type: none"> • PRIQTY was not specified for a CREATE TABLESPACE statement or for any subsequent ALTER TABLESPACE statements. • -1 was the most recently specified value for PRIQTY, either on the CREATE TABLESPACE statement or a subsequent ALTER TABLESPACE statement. <p>This column contains the null value when the value is unknown for objects created prior to Db2 12.</p>	
STORATYPE	CHAR(1) WITH DEFAULT NULL	<p>Type of storage allocation:</p> <p>E Explicit (storage group not used)</p> <p>I Implicit (storage group used)</p> <p>This column is not used for rows representing catalog indexes. Catalog data sets are managed by Db2</p> <p>This column contains the null value when the value is unknown for objects created prior to Db2 12.</p>	
STORNAME	VARCHAR(128) WITH DEFAULT NULL	<p>Name of storage group used for space allocation. Blank if storage group not used.</p> <p>This column is not used for rows representing catalog indexes. Catalog data sets are managed by Db2</p> <p>This column contains the null value when the value is unknown for objects created prior to Db2 12.</p>	

Table 307. SYSIBM.SYSINDEXES table column descriptions (continued)

Column name	Data type	Description	Use
VCATNAME	VARCHAR(24) WITH DEFAULT NULL	Name of integrated catalog facility catalog used for space allocation. This column is not used for rows representing catalog indexes. Catalog data sets are managed by Db2 This column contains the null value when the value is unknown for objects created prior to Db2 12.	
FREEPAGE	SMALLINT WITH DEFAULT NULL	Number of pages loaded before a page is left as free space. This column contains the null value when the value is unknown for objects created prior to Db2 12.	
PCTFREE	SMALLINT WITH DEFAULT NULL	Percentage of each page left as free space. This column contains the null value when the value is unknown for objects created prior to Db2 12.	
GBPCACHE	CHAR(1) WITH DEFAULT NULL	Group buffer pool cache option specified for this index or index partition. Blank Only changed pages are cached in the group buffer pool. A Changed and unchanged pages are cached in the group buffer pool. N No data is cached in the group buffer pool. This column contains the null value when the value is unknown for objects created prior to Db2 12.	
SECQTYI	INTEGER WITH DEFAULT NULL	Secondary space allocation in units of 4 KB storage. For user-managed data sets, the value is the secondary space allocation in units of 4 KB blocks. This column contains the null value when the value is unknown for objects created prior to Db2 12.	
ENFORCED_CONS	CHAR(1) NOT NULL WITH DEFAULT	Whether the index is an enforcing non-unique constraint. Blank The index does not enforce a non-unique constraint. F The index enforces a foreign key for a temporal referential constraint.	

Table 307. SYSIBM.SYSINDEXES table column descriptions (continued)

Column name	Data type	Description	Use
IMPLICIT	CHAR(1) NOT NULL WITH DEFAULT	Whether the index was implicitly created. Possible values are: Blank n/a N The index was explicitly created. Y The index was implicitly created.	
REGENERATETS	TIMESTAMP(12) NOT NULL	The time when the object was regenerated. The value is valid only for objects that can be regenerated. If no regeneration has occurred, this column contains the same value as the CREATEDTS column.	G
<u>FL 502</u> KEYLABEL	VARCHAR(192) NOT NULL WITH DEFAULT	The key label that is specified at the table level. Otherwise, the value is an empty string.	

SYSINDEXES_HIST catalog table

The SYSINDEXES_HIST catalog table contains rows from SYSINDEXES. The schema is SYSIBM.

Rows are added or changed in this table when RUNSTATS collects history statistics. Rows in this table can also be inserted, updated, and deleted.

Table 308. SYSIBM.SYSINDEXES_HIST table column descriptions

Column name	Data type	Description	Use
NAME	VARCHAR(128) NOT NULL	Name of the index.	G
CREATOR	VARCHAR(128) NOT NULL	The schema of the index.	G
TBNAME	VARCHAR(128) NOT NULL	Name of the table on which the index is defined.	G
TBCREATOR	VARCHAR(128) NOT NULL	The schema of the table.	G
CLUSTERING	CHAR(1) NOT NULL	Whether CLUSTER was specified when the index was created: N No Y Yes	G
NLEAF	INTEGER NOT NULL WITH DEFAULT -1	Number of active leaf pages in the index. The value is -1 if statistics have not been gathered.	S

Table 308. SYSIBM.SYSINDEXES_HIST table column descriptions (continued)

Column name	Data type	Description	Use
NLEVELS	SMALLINT NOT NULL WITH DEFAULT -1	Number of levels in the index tree. If the index is partitioned, it is the maximum of the number of levels in the index tree for all the partitions. The value is -1 if statistics have not been gathered.	S
STATSTIME	TIMESTAMP NOT NULL	If RUNSTATS or another utility with inline statistics updated the statistics, the date and time when the last utility invocation updated the statistics. The default value is '0001-01-01-00.00.00.000000'. The default value indicates that statistics were not collected. This column can be updated.	G
FIRSTKEYCARD	FLOAT(8) NOT NULL WITH DEFAULT -1	Number of distinct values of the first key column. This number is an estimate if updated while collecting statistics on a single partition. The value is -1 if statistics have not been gathered.	S
FULLKEYCARD	FLOAT(8) NOT NULL WITH DEFAULT -1	Number of distinct values of the key. The value is -1 if statistics have not been gathered.	S
CLUSTERRATIO	FLOAT(8) NOT NULL	Percentage of rows that are in clustering order. For a partitioning index, it is the weighted average of all index partitions in terms of the number of rows in the partition. The value is 0 if statistics have not been gathered. The value is -2 if the index is for an auxiliary table. For a sparse index, the statistic is based on the actual contents of the index.	G
SPACE	FLOAT(8) NOT NULL WITH DEFAULT -1	Number of kilobytes of DASD storage allocated to the index space partition. The value is -1 if statistics have not been gathered.	G
IBMREQD	CHAR(1) NOT NULL WITH DEFAULT 'N'	A value of Y indicates that the row was provided with the Db2 product code. For all other values, see Release dependency indicators . The value in this field is not a reliable indicator of release dependencies.	G
AVGKEYLEN	INTEGER NOT NULL WITH DEFAULT -1	Average length of keys within the index. The value is -1 if statistics have not been gathered. For a sparse index, the statistic is based on the actual contents of the index.	G
DATAREPEAT	FLOAT NOT NULL WITH DEFAULT -1	The anticipated number of data pages that will be touched following an index key order. This number is -1 if statistics have not been collected. This is an updatable column. For a sparse index, the statistic is based on the actual contents of the index.	G

SYSINDEXES_RTSECT catalog table

The SYSINDEXES_RTSECT catalog table is an auxiliary table for the RTSECTION column of the SYSIBM.SYSINDEXES table and is required to hold LOB data. The schema is SYSIBM.

Table 309. SYSIBM.SYSINDEXES_RTSECT table column descriptions

Column name	Data type	Description	Use
—	BLOB(1G) NOT NULL WITH DEFAULT	Internal use only.	I

SYSINDEXES_TREE catalog table

The SYSINDEXES_TREE catalog table is an auxiliary table for the PARSETREE column of the SYSINDEXES table and is required to hold LOB data. The schema is SYSIBM.

Table 310. SYSIBM.SYSINDEXES_TREE table column descriptions

Column name	Data type	Description	Use
—	BLOB(1G) NOT NULL WITH DEFAULT	Internal use only.	I

SYSINDEXPART catalog table

The SYSINDEXPART table contains one row for each nonpartitioned secondary index (NPSI) and one row for each partition of a partitioning index or a data-partitioned secondary index. The schema is SYSIBM.

Column name	Data type	Description	Use
PARTITION	SMALLINT NOT NULL	Partition number; Zero if index is not partitioned.	G
IXNAME	VARCHAR(128) NOT NULL	Name of the index.	G
IXCREATOR	VARCHAR(128) NOT NULL	The schema of the index.	G

Column name	Data type	Description	Use
PQTY	INTEGER NOT NULL	<p>For user-managed data sets, the value is the primary space allocation in units of 4KB storage blocks or -1.</p> <p>PQTY is based on a value of PRIQTY in the appropriate CREATE or ALTER INDEX statement. Unlike PQTY, however, PRIQTY asks for space in 1KB units.</p> <p>A value of -1 indicates that either of the following cases is true:</p> <ul style="list-style-type: none"> • PRIQTY was not specified for a CREATE INDEX statement or for any subsequent ALTER INDEX statements. • -1 was the most recently specified value for PRIQTY, either on the CREATE INDEX statement or a subsequent ALTER INDEX statement. 	G
SQTY	SMALLINT NOT NULL	<p>For user-managed data sets, the value is the secondary space allocation in units of 4KB storage blocks or -1.</p> <p>SQTY is based on a value of SECQTY in the appropriate CREATE or ALTER INDEX statement. Unlike SQTY, however, SECQTY asks for space in 1KB units.</p> <p>A value of -1 indicates that either of the following cases is true:</p> <ul style="list-style-type: none"> • SECQTY was not specified for a CREATE INDEX statement or for any subsequent ALTER INDEX statements. • -1 was the most recently specified value for SECQTY, either on the CREATE INDEX statement or a subsequent ALTER INDEX statement. <p>If the value does not fit into the column, the value of the column is 32767. See the description of column SECQTYI.</p>	G
STORATYPE	CHAR(1) NOT NULL	<p>Type of storage allocation:</p> <p>E Explicit, and STORNAME names an integrated catalog facility catalog</p> <p>I Implicit, and STORNAME names a storage group</p> <p>This column is not used for rows representing catalog indexes. Catalog data sets are managed by Db2</p>	G
STORNAME	VARCHAR(128) NOT NULL	<p>Name of storage group or integrated catalog facility catalog used for space allocation.</p> <p>This column is not used for rows representing catalog indexes. Catalog data sets are managed by Db2</p>	G

Column name	Data type	Description	Use
VCATNAME	VARCHAR(24) NOT NULL	Name of integrated catalog facility catalog used for space allocation. This column is not used for rows representing catalog indexes. Catalog data sets are managed by Db2	G
CARD	INTEGER NOT NULL	Not used	N
FAROFFPOS	INTEGER NOT NULL	Not used	N
LEAFDIST	INTEGER NOT NULL	100 times the average number of leaf pages between successive active leaf pages of the index. The value is -1 if statistics have not been gathered. The value is -2 if the index is an auxiliary index, a node ID index, or an XML index.	S
NEAROFFPOS	INTEGER NOT NULL	Not used	S
IBMREQD	CHAR(1) NOT NULL	A value of Y indicates that the row was provided with the Db2 product code. For all other values, see Release dependency indicators . The value in this field is not a reliable indicator of release dependencies.	G
LIMITKEY	VARCHAR(512) NOT NULL FOR BIT DATA	The high value of the limit key of the partition in an internal format. An empty string if the index is not partitioned or for a data-partitioned secondary index (DPSI). If any column of the key has a field procedure, the internal format is the encoded form of the value.	S
FREEPAGE	SMALLINT NOT NULL	Number of pages that are loaded before a page is left as free space.	G
PCTFREE	SMALLINT NOT NULL	Percentage of each leaf or nonleaf page that is left as free space.	G

Column name	Data type	Description	Use
SPACE	INTEGER NOT NULL WITH DEFAULT	<p>Number of kilobytes of DASD storage allocated to the index space partition, as determined by the last execution of the STOSPACE utility.</p> <p>0 The STOSPACE or RUNSTATS utility has not been run or the data set for the index has been created during the first insert operation or when the LOAD utility was run.</p> <p>-1 The index was defined with the DEFINE NO clause, which defers the physical creation of the data sets until data is first inserted into the index, and data has yet to be inserted into the index.</p> <p>-2 The value exceeds the maximum size for an integer value. See the SPACEF column value.</p> <p>A non-negative value Indicates that the data sets for the index space are defined with the underlying data sets allocated.</p> <p>The STOSPACE utility updates this value if the index is related to a storage group. The RUNSTATS utility updates this value if run with RUNSTATS INDEX and UPDATE(ALL) or UPDATE(SPACE).</p>	G
STATSTIME	TIMESTAMP NOT NULL WITH DEFAULT	<p>If RUNSTATS or another utility with inline statistics updated the statistics, the date and time when the last utility invocation updated the statistics. The default value is '0001-01-01-00.00.00.000000'. The default value indicates that statistics were not collected. This column can be updated.</p>	G
INDEXTYPE	CHAR(1) NOT NULL	Not used.	N
GBPCACHE	CHAR(1) NOT NULL WITH DEFAULT	<p>Group buffer pool cache option specified for this index or index partition.</p> <p>blank Only changed pages are cached in the group buffer pool.</p> <p>A Changed and unchanged pages are cached in the group buffer pool.</p> <p>N No data is cached in the group buffer pool.</p>	G

Column name	Data type	Description	Use
FAROFFPOSF	FLOAT NOT NULL WITH DEFAULT -1	Number of referred to rows far from optimal position because of an insert into a full page. The value is -1 if statistics have not been gathered. The value is -2 if the index is an auxiliary index, a node ID index, or an XML index. The column is not applicable for an index on an auxiliary table. For a sparse index, the statistic is based on the actual contents of the index.	S
NEAROFFPOSF	FLOAT NOT NULL WITH DEFAULT -1	Number of referred to rows near, but not at optimal position, because of an insert into a full page. The value is -2 if the index is an auxiliary index, a node ID index, or an XML index. Not applicable for an index on an auxiliary table. For a sparse index, the statistic is based on the actual contents of the index.	S
CARDF	FLOAT NOT NULL WITH DEFAULT -1	Number of RIDs in the index that refer to data rows or LOBs. The value is -1 if statistics have not been gathered. For a sparse index, the statistic is based on the actual contents of the index.	S
SECQTYI	INTEGER NOT NULL WITH DEFAULT	Secondary space allocation in units of 4KB storage. For user-managed data sets, the value is the secondary space allocation in units of 4KB blocks.	G
IPREFIX	CHAR(1) NOT NULL WITH DEFAULT 'I'	The first character of the instance qualifier for this index's data set name. 'I' or 'J' are the only valid characters for this field. The default is 'I'.	G
ALTEREDTS	TIMESTAMP NOT NULL WITH DEFAULT	Time when the most recent ALTER INDEX statement was executed for the index. If no ALTER INDEX statement has been applied, the value is '0001-01-01.00.00.00.000000'.	G
SPACEF	FLOAT(8) NOT NULL WITH DEFAULT -1	Kilobytes of DASD storage. The value is -1 if statistics have not been gathered. This is an updatable column.	G
DSNUM	INTEGER NOT NULL WITH DEFAULT -1	Number of data sets. The value is -1 if statistics have not been gathered. This is an updatable column.	G
EXTENTS	INTEGER NOT NULL WITH DEFAULT -1	Number of data set extents. The value is -1 if statistics have not been gathered. This is an updatable column. This value is only for the last DSNUM for the object.	G

Column name	Data type	Description	Use
PSEUDO_DEL_ENTRIES	INTEGER NOT NULL WITH DEFAULT -1	Number of pseudo deleted entries (entries that are logically deleted but still physically present in the index). For a non-unique index, value is the number of RIDs that are pseudo deleted. For a unique index, the value is the number of keys and RIDs that are pseudo deleted. The value is -1 if statistics have not been gathered. This is an updatable column.	G
LEAFNEAR	INTEGER NOT NULL WITH DEFAULT -1	Number of leaf pages physically near previous leaf page for successive active leaf pages. The value is -1 if statistics have not been gathered. This is an updatable column.	S
LEAFFAR	INTEGER NOT NULL WITH DEFAULT -1	Number of leaf pages located physically far away from previous leaf pages for successive (active leaf) pages accessed in an index scan. The value is -1 if statistics have not been gathered. This is an updatable column.	S
OLDEST_VERSION	SMALLINT NOT NULL WITH DEFAULT	The version number describing the oldest format of data in the index part and any image copies of the index part.	G
CREATEDTS	TIMESTAMP NOT NULL WITH DEFAULT -1	Time when the partition was created.	G
AVGKEYLEN	INTEGER NOT NULL WITH DEFAULT -1	Average length of keys within the index. The value is -1 if statistics have not been gathered. For a sparse index, the statistic is based on the actual contents of the index.	G
RBA_FORMAT	CHAR(1) NOT NULL WITH DEFAULT	The RBA and LRSN format for the page sets of the index partition: B The page sets are still in the basic 6-byte format. E The page sets are converted to the extended 10-byte format. U The format is undefined because DEFINE NO was specified when the index was created. blank The page sets are still in the basic 6-byte format, the index was created before Db2 11 new-function mode (NFM), and no utility that sets the RBA_FORMAT value has run for the index partition in Db2 11 NFM or higher.	G
DSSIZE	INTEGER WITH DEFAULT NULL	The maximum size in KB of a partitioned index data set for a table space with relative page numbers. 0 for nonpartitioned indexes or partitioned indexes for table spaces with absolute page numbers. NULL for indexes that were created before Db2 12.	G

Column name	Data type	Description	Use
PAGENUM	CHAR(1) NOT NULL WITH DEFAULT 'A'	Format of pages for the index, indicating absolute or relative page numbering. A Indicates absolute addressing so that PAGENUM contains the embedded partition number. R Indicates relative addressing so that PAGENUM contains only the relative page number. NULL for objects that were created before Db2 12.	G
LIMITKEY_EXTERNAL	VARCHAR(765) NOT NULL	Reserved for future IBM use.	I

SYSINDEXPART_HIST catalog table

The SYSINDEXPART_HIST catalog table contains rows from SYSINDEXPART. The schema is SYSIBM.

Rows are added or changed in this table when RUNSTATS collects history statistics. Rows in this table can also be inserted, updated, and deleted.

Table 311. SYSIBM.SYSINDEXPART_HIST table column descriptions

Column name	Data type	Description	Use
PARTITION	SMALLINT NOT NULL	Partition number. Zero if index is not partitioned.	G
IXNAME	VARCHAR(128) NOT NULL	Name of the index.	G
IXCREATOR	VARCHAR(128) NOT NULL	The schema of the index.	G
PQTY	INTEGER NOT NULL	For user-managed data sets, the value is the primary space allocation in units of 4KB storage blocks or -1. For user-specified values of PRIQTY other than -1, the value is set to the primary space allocation only if RUNSTATS INDEX with UPDATE(ALL) or UPDATE(SPACE) is executed; otherwise, the value is zero. PQTY is based on a value of PRIQTY in the appropriate CREATE or ALTER INDEX statement. Unlike PQTY, however, PRIQTY asks for space in 1KB units. A value of -1 indicates that either of the following cases is true: <ul style="list-style-type: none"> • PRIQTY was not specified for a CREATE INDEX statement or for any subsequent ALTER INDEX statements. • -1 was the most recently specified value for PRIQTY, either on the CREATE INDEX statement or a subsequent ALTER INDEX statement. If a storage group is not used, the value is 0.	G

Table 311. SYSIBM.SYSINDEXPART_HIST table column descriptions (continued)

Column name	Data type	Description	Use
SECQTYI	INTEGER NOT NULL	<p>For user-managed data sets, the value is the secondary space allocation in units of 4KB storage blocks or -1.</p> <p>For user-specified values of SECQTY other than -1, the value is set to the secondary space allocation only if RUNSTATS INDEX with UPDATE(ALL) or UPDATE(SPACE) is executed; otherwise, the value is zero. SQTY is based on a value of SECQTY in the appropriate CREATE or ALTER INDEX statement. Unlike SQTY, however, SECQTY asks for space in 1KB units.</p> <p>A value of -1 indicates that either of the following cases is true:</p> <ul style="list-style-type: none"> SECQTY was not specified for a CREATE INDEX statement or for any subsequent ALTER INDEX statements. -1 was the most recently specified value for SECQTY, either on the CREATE INDEX statement or a subsequent ALTER INDEX statement. <p>If a storage group is not used, the value is 0.</p>	G
LEAFDIST	INTEGER NOT NULL WITH DEFAULT -1	100 times the average number of leaf pages between successive active leaf pages of the index. The value is -1 if statistics have not been gathered.	S
SPACEF	FLOAT(8) NOT NULL WITH DEFAULT -1	Number of kilobytes of DASD storage allocated to the index space partition. The value is -1 if statistics have not been gathered.	G
STATSTIME	TIMESTAMP NOT NULL	If RUNSTATS or another utility with inline statistics updated the statistics, the date and time when the last utility invocation updated the statistics. The default value is '0001-01-01-00.00.00.000000'. The default value indicates that statistics were not collected. This column can be updated.	G
FAROFFPOSF	FLOAT(8) NOT NULL WITH DEFAULT -1	<p>Number of referred to rows far from optimal position because of an insert into a full page. The value is -1 if statistics have not been gathered. The column is not applicable for an index on an auxiliary table.</p> <p>For a sparse index, the statistic is based on the actual contents of the index.</p>	S
NEAROFFPOSF	FLOAT(8) NOT NULL WITH DEFAULT -1	<p>Number of referred to rows near, but not at optimal position, because of an insert into a full page. Not applicable for an index on an auxiliary table. The value is -1 if statistics have not been gathered.</p> <p>For a sparse index, the statistic is based on the actual contents of the index.</p>	S

Table 311. SYSIBM.SYSINDEXPART_HIST table column descriptions (continued)

Column name	Data type	Description	Use
CARDF	FLOAT(8) NOT NULL WITH DEFAULT -1	Number of RIDs in the index that refer to data rows or LOBs. The value is -1 if statistics have not been gathered. For a sparse index, the statistic is based on the actual contents of the index.	S
EXTENTS	INTEGER NOT NULL WITH DEFAULT -1	Number of data set extents. The value is -1 if statistics have not been gathered. This value is only for the last DSNUM for the object.	G
PSEUDO_DEL_ENTRIES	INTEGER NOT NULL WITH DEFAULT -1	Number of pseudo deleted entries. The value is -1 if statistics have not been gathered.	G
DSNUM	INTEGER NOT NULL WITH DEFAULT -1	Data set number within the table space. For partitioned index spaces, this value corresponds to the partition number for a single partition copy, or 0 for a copy of an entire partitioned index space. The value is -1 if statistics have not been gathered.	G
IBMREQD	CHAR(1) NOT NULL WITH DEFAULT 'N'	A value of Y indicates that the row was provided with the Db2 product code. For all other values, see Release dependency indicators . The value in this field is not a reliable indicator of release dependencies.	G
LEAFNEAR	INTEGER NOT NULL WITH DEFAULT -1	Number of leaf pages physically near previous leaf page for successive active leaf pages. The value is -1 if statistics have not been gathered. This is an updatable column.	S
LEAFFAR	INTEGER NOT NULL WITH DEFAULT -1	Number of leaf pages located physically far away from previous leaf pages for successive (active leaf) pages accessed in an index scan. The value is -1 if statistics have not been gathered. This is an updatable column.	S
AVGKEYLEN	INTEGER NOT NULL WITH DEFAULT -1	Average length of keys within the index. The value is -1 if statistics have not been gathered. For a sparse index, the statistic is based on the actual contents of the index.	G

SYSINDEXSPACESTATS catalog table

The SYSINDEXSPACESTATS table contains real time statistics for index spaces. The schema is SYSIBM.

Rows in this table can be inserted, updated, and deleted. However, the following columns cannot be updated: SYS_START, SYS_END, and TRANS_START.

In data sharing environments, the values in SYSIBM.SYSINDEXSPACESTATS can be negative for short periods of time for certain situations.

SYSIBM.SYSINDEXSPACESTATS has an associated history table, SYSIBM.SYSIXSPACESTATS_H, which provides temporal versioning of the catalog table. Both tables contain the same columns, with the same data types. The temporal relationship must be enabled before the history table can be used. Rows in

the history table can be inserted, updated, and deleted with proper authorization. For information about enabling the temporal relationship, see [“Temporal versioning for Db2 catalog tables”](#) on page 2742.

Column name	Data type	Description	Use
UPDATESTATSTIME	TIMESTAMP NOT NULL WITH DEFAULT	The timestamp that the row in the SYSINDEXSPACESTATS table is inserted or last updated.	G
NLEVELS	SMALLINT	The number of levels in the index tree. A null value indicates that the number of levels is unknown.	G
NPAGES	INTEGER	The number of pages in the index tree that contain only pseudo-deleted index entries. This is an updatable column.	G
NLEAF	INTEGER	The number of leaf pages in the index. This is an updatable column.	G
NACTIVE	INTEGER	The number of active pages in the index space or partition. This value is equivalent to the number of pre-formatted pages. A null value indicates that the number of active pages is unknown.	G
SPACE	INTEGER	The amount of space, in KB, that is allocated to the index space or partition. For multi-piece, linear page sets, this value is the amount of space in all data sets. A null value indicates the amount of space is unknown.	G
EXTENTS	SMALLINT	The number of extents in the index space or partition. For multi-piece index spaces, this value is the number of extents for the last data sets. For a data set that is stripped across multiple volumes, the value is the number of logical extents. A null value indicates the number of extents is unknown.	G
LOADRLASTTIME	TIMESTAMP	The timestamp that the LOAD REPLACE utility was last run on the index space or partition. A null value indicates that the LOAD REPLACE utility has never been run on the index space or partition or that the timestamp is unknown.	G
REBUILDLASTTIME	TIMESTAMP	The timestamp that the REBUILD INDEX utility was last run on the index space or partition. A null value indicates that the timestamp that the REBUILD INDEX was last run is unknown.	G
REORGLASTTIME	TIMESTAMP	The timestamp when the REORG INDEX utility was last run on the index space or partition, or if the REORG INDEX utility has not been run, the time when the index space or partition was created. A null value indicates that the timestamp is unknown.	G

Column name	Data type	Description	Use
REORGINSERTS	INTEGER	The number of index entries that have been inserted into the index space or partition since the last time the REORG, REBUILD INDEX, or LOAD REPLACE utilities were run, or since the object was created. A null value indicates that the number of inserted index entries is unknown.	G
REORGDELETES	INTEGER	The number of index entries that have been deleted from the index space or partition since the last time the REORG, REBUILD INDEX, or LOAD REPLACE utilities were run, or since the object was created. A null value indicates that the number of deleted index entries is unknown.	G
REORGAPPENDINSERT	INTEGER	The number of index entries that have a key value that is greater than the maximum key value in the index or partition that have been inserted into the index space or partition since the last time the REORG, REBUILD INDEX, or LOAD REPLACE utilities were run, or since the object was created. A null value indicates that the number of inserted index entries is unknown.	G
REORGPSEUDODELETES	INTEGER	The number of pseudo-deleted index entries stored in the index space or partition. A pseudo-delete is a RID entry that has been marked as deleted. A null value indicates that the number of pseudo-deleted index entries is unknown.	G
REORGMASSDELETE	INTEGER	The number of mass deletes from a segmented or LOB table space, or the number of dropped tables from a segmented table space since the last time the REORG or LOAD REPLACE utilities were run, or since the object was created. A null value indicates that the number of mass deletes is unknown.	G

Column name	Data type	Description	Use
REORGLAUFNEAR	INTEGER	<p>The net number of leaf pages located physically near (within 2–16 pages) previous pages for successive active leaf pages since the object was created.</p> <p>A null value means that the value is unknown. A negative value is possible in some cases.</p> <p>Two index leaf pages are considered near if the distance is within 2–16 pages. (The optimal distance is 1 page.)</p> <p>Conditions that can increase the value of this counter</p> <ul style="list-style-type: none"> • A leaf page is added during a page split and the distance between the predecessor page and new page, or between the new page and the successor page, is near. • An index page is deleted and the distance between the new predecessor and successor pages is near <p>Conditions that can decrease the value of this counter</p> <ul style="list-style-type: none"> • A leaf page is deleted the distance between the predecessor page and the deleted page, or between the successor page and the deleted page, was near. • An index page is added during a page split and the distance between the original predecessor and successor pages was near. 	G

Column name	Data type	Description	Use
REORGLAFFAR	INTEGER	<p>The net number of leaf pages located physically far away (more than 16 pages away) from previous leaf pages for successive active leaf pages since the object was created.</p> <p>A null value means that the value is unknown.</p> <p>Two index leaf pages are considered <i>far</i> apart if the distance is greater than 16 pages.</p> <p>Conditions that can increase the value of this counter</p> <ul style="list-style-type: none"> • A leaf page is added during a page split and the distance between the predecessor page and new page, or between the new page and successor page, is far. • An index page is deleted the distance between the new predecessor and successor pages is far. <p>Conditions that can decrease the value of this counter</p> <ul style="list-style-type: none"> • A leaf page is deleted and the distance between the predecessor page and the deleted page, or between the successor page and the deleted page, was far. • An index page is added during a page split and the distance between the predecessor and successor pages was far. 	G
REORGNUMLEVELS	INTEGER	<p>The number of levels in the index tree that were added or removed since the last REORG, REBUILD INDEX, or LOAD REPLACE, or the object was created.</p> <p>A null value means that the number of added or deleted levels is unknown.</p>	G
STATSLASTTIME	TIMESTAMP	<p>The timestamp of the last time that the RUNSTATS utility is run on the index space or partition, or the time when the index space or partition was created.</p>	G
STATSINSERTS	INTEGER	<p>The number of index entries that have been inserted into the index space or partition since the last time that the RUNSTATS utility was run, or since the object was created.</p> <p>A null value indicates that the number of inserted index entries is unknown.</p>	G
STATSDELETES	INTEGER	<p>The number of index entries that have been deleted since the last RUNSTATS on the index space or partition, or since the object was created.</p> <p>A null value means that the number of deleted index entries is unknown.</p>	G

Column name	Data type	Description	Use
STATSMASDELETE	INTEGER	The number of times that the index or index space partition was mass deleted since the last RUNSTATS, or the object was created. A null value indicates that the number of mass deletes is unknown.	G
COPYLASTTIME	TIMESTAMP	The timestamp of the last full image copy on the index space or partition. A null value means that COPY has never been run on the index space or partition, or that the timestamp of the last full image copy is unknown.	G
COPYUPDATEDPAGES	INTEGER	If the COPY utility was run with a SHRLEVEL value other than CHANGE, this value is the number of distinct pages that have been updated since the last time that the COPY utility was run. If the COPY utility was run with SHRLEVEL CHANGE, this value is the total number of distinct pages that were updated during the time that the last COPY utility was run, and since the last time that the COPY utility was run. A null value indicates that the number of updated pages is unknown.	G
COPYCHANGES	INTEGER	If the COPY utility was run with a SHRLEVEL value other than CHANGE, this value is the number of insert, update, and delete operations since the last time that the COPY utility was run. If the COPY utility was run with SHRLEVEL CHANGE, this value is the total number of insert, update, and delete operations, or the number of rows loaded, during the time that the last COPY utility was run, and since the last time that the COPY utility was run. A null value indicates that the number of insert, update, and delete operations is unknown.	G
COPYUPDATELRSN	CHAR(10) FOR BIT DATA	The LRSN or RBA of the first update that occurs after the last time the COPY utility was run. A null value indicates that the LRSN or RBA is unknown.	G

Column name	Data type	Description	Use
COPYUPDATETIME	TIMESTAMP	<p>If the COPY utility was run with a SHRLEVEL value other than CHANGE, this value is the timestamp of the first update that occurred after the last time that the COPY utility was run.</p> <p>If the COPY utility was run with SHRLEVEL CHANGE, this value is the timestamp of the first update that occurred during the time that the last COPY utility was run, or since the last time that the COPY utility was run.</p> <p>A null value indicates that the timestamp is unknown.</p>	G
IBMREQD	CHAR(1) NOT NULL	<p>A value of Y indicates that the row was provided with the Db2 product code. For all other values, see Release dependency indicators.</p> <p>The value in this field is not a reliable indicator of release dependencies.</p>	G
DBID	SMALLINT NOT NULL	The internal identifier of the database.	G
ISOBID	SMALLINT NOT NULL	The internal identifier of the index space page set descriptor.	I
PSID	SMALLINT NOT NULL	The internal identifier of the table space page set descriptor for the table space that is associated with the index.	G
PARTITION	SMALLINT NOT NULL	The data set number within the index space. For partitioned index spaces, this value corresponds to the partition number for a single partition. For non-partitioned index spaces, this value is 0.	G
INSTANCE	SMALLINT NOT NULL WITH DEFAULT 1	Indicates if the object is associated with data set 1 or 2. This is an updatable column.	G
TOTALENTRIES	BIGINT	<p>The number of entries, including duplicate entries, in the index space or partition.</p> <p>A null value indicates that the number of entries is unknown.</p>	G
DBNAME	VARCHAR(24) NOT NULL	The name of the database.	G
NAME	VARCHAR(128) NOT NULL	The name of the index.	G
CREATOR	VARCHAR(128) NOT NULL	The schema of the index.	G

Column name	Data type	Description	Use
INDEXSPACE	VARCHAR(24) NOT NULL	The name of the index space.	G
LASTUSED	DATE	<p>The date when the index was last used in an access path for a SELECT, FETCH, searched UPDATE, or searched DELETE statement, or was used to enforce referential integrity constraints. If this field value indicates that an index has not been used for an extended period of time, consider dropping the index.</p> <p>For a data-partitioned secondary index, this column is only updated for one partition, even though more than one partition is accessed.</p> <p>The default value is NULL.</p>	G
REORGINDEXACCESS	BIGINT	<p>The number of times since the object was created, or since the last REORG, REBUILD INDEX, or LOAD REPLACE, that the index was used in one of the following situations:</p> <ul style="list-style-type: none"> • In an access path for a SELECT, FETCH, searched UPDATE, or searched DELETE statement • For enforcement of referential integrity constraints <p>For hash overflow indexes, this value is the number of times that Db2 used the hash overflow index.</p> <p>Use this value with other recommendations to determine when to run REORG INDEX. For example, when the ratio of SYSTABLESPACESTATS.TOTALROWS to SYSINDEXSPACESTATS.TOTALENTRIES indicates that REORG INDEX needs to be run, but this value is very low, REORG INDEX might not yet be necessary.</p> <p>A null value indicates that the number of times the index was used is unknown.</p>	G
DRIVETYPE	CHAR(3) NOT NULL WITH DEFAULT	<p>The drive type on which the index or index partition data set is defined.</p> <p>HDD Hard Disk Drive</p> <p>SSD Solid State Drive</p> <p>For multi-volume data sets, the drive type is set to SSD if any volume is SSD. For multi-piece linear page sets, the drive type of the first data set is used.</p>	G
—	BIGINT	Reserved for future IBM use.	R

Column name	Data type	Description	Use
GETPAGES	BIGINT	The number of getpage requests for the index space since the object was created, or since the last REORG, LOAD RELACE, or REBUILD INDEX was run. The value wraps if it exceeds the largest possible BIGINT value, which is 9223372036854775807.	G
SYS_START	TIMESTAMP(12) NOT NULL GENERATED ALWAYS AS ROW BEGIN	The row-begin column of the SYSTEM_TIME period, for system-period data versioning.	G
SYS_END	TIMESTAMP(12) NOT NULL GENERATED ALWAYS AS ROW END	The row-end column of the SYSTEM_TIME period, for system-period data versioning.	G
TRANS_START	TIMESTAMP(12) NOT NULL GENERATED ALWAYS AS TRANSACTION START ID	The transaction-start-ID column, for system-period data versioning.	G

Related concepts

How Db2 maintains in-memory statistics in data sharing ([Db2 Data Sharing Planning and Administration](#))

Related tasks

[Setting up your system for real-time statistics \(Db2 Performance\)](#)

SYSINDEXSTATS catalog table

The SYSINDEXSTATS table contains one row for each partition of a partitioning index or a data-partitioned secondary index. The schema is SYSIBM.

Rows in this table can be inserted, updated, and deleted.

Important: Use care when issuing SQL statements or using tools to update statistics values in catalog tables. If such updates introduce invalid data, unpredictable results can occur, including abends for RUNSTATS and other utilities. If such problems occur, you can run the RUNSTATS utility and collect statistics at the table space level to resolve the problems, in most cases.

Column name	Data type	Description	Use
FIRSTKEYCARD	INTEGER NOT NULL	For the index partition, number of distinct values of the first key column. For a sparse index, the statistic is based on the actual contents of the index.	S
FULLKEYCARD	INTEGER NOT NULL	For the index partition, number of distinct values of the key. For a sparse index, the statistic is based on the actual contents of the index.	S

Column name	Data type	Description	Use
NLEAF	INTEGER NOT NULL	Number of active leaf pages in the index partition.	S
NLEVELS	SMALLINT NOT NULL	Number of levels in the index tree.	S
IOFACTOR	SMALLINT NOT NULL	Not used.	N
PREFETCHFACTOR	SMALLINT NOT NULL	Not used.	N
CLUSTERRATIO	SMALLINT NOT NULL	For the index partition, the percentage of rows that are in clustering order. The value is 0 if statistics have not been gathered. For a sparse index, the statistic is based on the actual contents of the index.	N
STATSTIME	TIMESTAMP NOT NULL	If RUNSTATS or another utility with inline statistics updated the statistics, the date and time when the last utility invocation updated the statistics. The default value is '0001-01-01-00.00.00.000000'. The default value indicates that statistics were not collected. This column can be updated.	G
IBMREQD	CHAR(1) NOT NULL	A value of Y indicates that the row was provided with the Db2 product code. For all other values, see Release dependency indicators . The value in this field is not a reliable indicator of release dependencies.	G
PARTITION	SMALLINT NOT NULL	Partition number of the index.	G
OWNER	VARCHAR(128) NOT NULL	The schema of the index.	G
NAME	VARCHAR(128) NOT NULL	Name of the index.	G
KEYCOUNT	INTEGER NOT NULL	Total number of RIDs in the index partition. The value is -1 if statistics have not been gathered. Total number of rows in the partition. For a sparse index, the statistic is based on the actual contents of the index.	S
FIRSTKEYCARDF	FLOAT NOT NULL WITH DEFAULT -1	For the index partition, number of distinct values of the first key column. For a sparse index, the statistic is based on the actual contents of the index.	S

Column name	Data type	Description	Use
FULLKEYCARDF	FLOAT NOT NULL WITH DEFAULT -1	For the index partition, number of distinct values of the key. For a sparse index, the statistic is based on the actual contents of the index.	S
KEYCOUNTF	FLOAT WITH DEFAULT -1	Total number of RIDs in the index partition. The value is -1 if statistics have not been gathered.Total number of rows in the partition. For a sparse index, the statistic is based on the actual contents of the index.	S
CLUSTERRATIOF	FLOAT NOT NULL WITH DEFAULT	For the index partition, the value, when multiplied by 100, is the percentage of rows that are in clustering order. For example, a value of '.9125' indicates 91.25%. The value is 0 if statistics have not been gathered. For a sparse index, the statistic is based on the actual contents of the index.	G
—	VARCHAR(1000) NOT NULL WITH DEFAULT FOR BIT DATA	Internal use only.	I
DATAREPEATFACTORF	FLOAT NOT NULL WITH DEFAULT -1	The anticipated number of data pages that will be touched following an index key order. This number is -1 if statistics have not been collected. This is an updatable column. For a sparse index, the statistic is based on the actual contents of the index.	G

SYSINDEXSTATS_HIST catalog table

The SYSINDEXSTATS_HIST catalog table contains rows from the SYSINDEXSTATS table. The schema is SYSIBM.

Rows are added or changed in this table when RUNSTATS collects history statistics. Rows in this table can also be inserted, updated, and deleted.

Table 312. SYSIBM.SYSINDEXSTATS_HIST table column descriptions

Column name	Data type	Description	Use
NLEAF	INTEGER NOT NULL WITH DEFAULT -1	Number of active leaf pages in the index partition. The value is -1 if statistics have not been gathered.	S
NLEVELS	SMALLINT NOT NULL WITH DEFAULT -1	Number of levels in the index tree. The value is -1 if statistics have not been gathered.	S

Table 312. SYSIBM.SYSINDEXSTATS_HIST table column descriptions (continued)

Column name	Data type	Description	Use
STATSTIME	TIMESTAMP NOT NULL	If RUNSTATS or another utility with inline statistics updated the statistics, the date and time when the last utility invocation updated the statistics. The default value is '0001-01-01-00.00.00.000000'. The default value indicates that statistics were not collected. This column can be updated.	G
PARTITION	SMALLINT NOT NULL	Partition number of the index.	G
OWNER	VARCHAR(128) NOT NULL	The schema of the index.	G
NAME	VARCHAR(128) NOT NULL	Name of the index.	G
FIRSTKEYCARDF	FLOAT(8) NOT NULL WITH DEFAULT -1	For the index partition, number of distinct values of the first key column. The value is -1 if statistics have not been gathered.	S
FULLKEYCARDF	FLOAT(8) NOT NULL WITH DEFAULT -1	For the index partition, number of distinct values of the key. The value is -1 if statistics have not been gathered.	S
KEYCOUNTF	FLOAT(8) NOT NULL WITH DEFAULT -1	Total number of RIDs in the index partition. The value is -1 if statistics have not been gathered. Total number of rows in the partition. The value is -1 if statistics have not been gathered. For a sparse index, the statistic is based on the actual contents of the index.	S
CLUSTERRATIOF	FLOAT(8) NOT NULL	For the index partition, the value, when multiplied by 100, is the percentage of rows that are in clustering order. For example, a value of '0.9125' indicates 91.25%. The value is 0 if statistics have not been gathered. For a sparse index, the statistic is based on the actual contents of the index.	G
IBMREQD	CHAR(1) NOT NULL WITH DEFAULT 'N'	A value of Y indicates that the row was provided with the Db2 product code. For all other values, see Release dependency indicators . The value in this field is not a reliable indicator of release dependencies.	G

Table 312. SYSIBM.SYSINDEXSTATS_HIST table column descriptions (continued)

Column name	Data type	Description	Use
DATAREPEATFACTORF	FLOAT NOT NULL WITH DEFAULT -1	The anticipated number of data pages that will be touched following an index key order. This number is -1 if statistics have not been collected. This is an updatable column. For a sparse index, the statistic is based on the actual contents of the index.	G

SYSJARCLASS_SOURCE catalog table

The SYSJARCLASS_SOURCE catalog table is an auxiliary table for SYSIBM.SYSJARCONTENTS. The schema is SYSIBM.

Table 313. SYSIBM.SYSJARCONTENTS table column descriptions

Column name	Data type	Description	Use
CLASS_SOURCE	CLOB(10M) NOT NULL	The contents of the class in the JAR file.	G

SYSJARCONTENTS catalog table

The SYSJARCONTENTS table contains Java class source for an installed JAR file. The schema is SYSIBM.

Table 314. SYSIBM.SYSJARCONTENTS table column descriptions

Column name	Data type	Description	Use
JARSCHEMA	VARCHAR(128) NOT NULL	The schema of the JAR file.	G
JAR_ID	VARCHAR(128) NOT NULL	The name of the JAR file.	G
CLASS	VARCHAR(384) NOT NULL	The class name contained in the JAR file.	G
CLASS_SOURCE_ROWID	ROWID NOT NULL GENERATED ALWAYS	ID used to support CLOB data type.	G
CLASS_SOURCE	CLOB(10M) NOT NULL	The contents of the class in the JAR file.	G
IBMREQD	CHAR(1) NOT NULL WITH DEFAULT 'N'	A value of Y indicates that the row was provided with the Db2 product code. For all other values, see Release dependency indicators . The value in this field is not a reliable indicator of release dependencies.	G

SYSJARDATA catalog table

The SYSJARDATA table is an auxiliary table for SYSIBM.SYSJAROBJECTS. The schema is SYSIBM.

Table 315. SYSIBM.SYSJARDATA table column descriptions

Column name	Data type	Description	Use
JAR_DATA	BLOB(100M) NOT NULL	The contents of the JAR file.	G

SYSJAROBJECTS catalog table

The SYSJAROBJECTS table contains binary large object representing the installed JAR file. The schema is SYSIBM.

Table 316. SYSIBM.SYSJAROBJECTS table column descriptions

Column name	Data type	Description	Use
JARSCHEMA	VARCHAR(128) NOT NULL	The schema of the JAR file.	G
JAR_ID	VARCHAR(128) NOT NULL	The name of the JAR file.	G
OWNER	VARCHAR(128) NOT NULL	Authorization ID of the owner of the JAR object.	G
JAR_DATA_ROWID	ROWID NOT NULL GENERATED ALWAYS	ID used to support BLOB data type.	G
JAR_DATA	BLOB(100M) NOT NULL	The contents of the JAR file. This is an updatable column.	G
PATH	VARCHAR(2048) NOT NULL	The class resolution path of the JAR file. This is an updatable column.	G
CREATEDTS	TIMESTAMP NOT NULL	Time when the JAR object was created.	G
ALTEREDTS	TIMESTAMP NOT NULL	Time when the JAR object was altered.	G
IBMREQD	CHAR(1) NOT NULL WITH DEFAULT 'N'	A value of Y indicates that the row was provided with the Db2 product code. For all other values, see Release dependency indicators . The value in this field is not a reliable indicator of release dependencies.	G

Table 316. SYSIBM.SYSJAROBJECTS table column descriptions (continued)

Column name	Data type	Description	Use
OWNERTYPE	CHAR(1) NOT NULL WITH DEFAULT	Indicates the type of owner: blank Authorization ID L Role	G

SYSJAVAOPTS catalog table

The SYSJAVAOPTS table contains build options used during INSTALL_JAR. The schema is SYSIBM.

Table 317. SYSIBM.SYSJAVAOPTS table column descriptions

Column name	Data type	Description	Use
JARSCHEMA	VARCHAR(128) NOT NULL	The schema of the JAR file.	G
JAR_ID	VARCHAR(128) NOT NULL	The name of the JAR file.	G
BUILDSHEMA	VARCHAR(128) NOT NULL	Schema name for BUILDNAME.	G
BUILDNAME	VARCHAR(128) NOT NULL	Procedure used to create the routine.	G
BUILDOWNER	VARCHAR(128) NOT NULL	Authorization ID used to create the routine.	G
DBRMLIB	VARCHAR(256) NOT NULL	PDS name where DBRM is located.	G
HPJCOMPILE_OPTS	VARCHAR(512) NOT NULL	HPJ compile options used to install the routine.	G
BIND_OPTS	VARCHAR(2048) NOT NULL	Bind options used to install the routine.	G
POBJECT_LIB	VARCHAR(256) NOT NULL	PDSE name where program object is located.	G
IBMREQD	CHAR(1) NOT NULL WITH DEFAULT 'N'	A value of Y indicates that the row was provided with the Db2 product code. For all other values, see Release dependency indicators . The value in this field is not a reliable indicator of release dependencies.	G

SYSJAVAPATHS catalog table

The SYSJAVAPATHS table contains the complete class resolution path of a JAR file, and records the dependencies that one JAR file has on the JAR files in its Java path. The schema is SYSIBM.

Table 318. SYSIBM.SYSJAVAPATHS table column descriptions

Column name	Data type	Description	Use
JARSCHEMA	VARCHAR(128) NOT NULL	The schema of the JAR file.	G
JAR_ID	VARCHAR(128) NOT NULL	The name of the JAR file.	G
OWNER	VARCHAR(128) NOT NULL	Authorization ID of the owner of the JAR object.	G
ORDINAL	SMALLINT NOT NULL	The ordinal number of the path element within the JAR file's Java path.	G
PE_CLASS_PATTERN	VARCHAR(2048) NOT NULL	The pattern for the names of the classes that are to be searched for in this path element's JAR file.	G
PE_JARSCHEMA	VARCHAR(128) NOT NULL	The schema of this path element's JAR file.	G
PE_JAR_ID	VARCHAR(128) NOT NULL	The name of this path element's JAR file.	G
IBMREQD	CHAR(1) NOT NULL WITH DEFAULT 'N'	A value of Y indicates that the row was provided with the Db2 product code. For all other values, see Release dependency indicators . The value in this field is not a reliable indicator of release dependencies.	G

SYSKEYCOLUSE catalog table

The SYSKEYCOLUSE table contains a row for every column in a unique constraint (primary key or unique key) from the SYSIBM.SYSTABCONST table. The schema is SYSIBM.

Table 319. SYSIBM.SYSKEYCOLUSE table column descriptions

Column name	Data type	Description	Use
CONSTNAME	VARCHAR(128) NOT NULL	Name of the constraint.	G
TBCREATOR	VARCHAR(128) NOT NULL	Schema or qualifier of the table on which the constraint is defined.	G
TBNAME	VARCHAR(128) NOT NULL	Name of the table on which the constraint is defined.	G

Table 319. SYSIBM.SYSKEYCOLUSE table column descriptions (continued)

Column name	Data type	Description	Use
COLNAME	VARCHAR(128) NOT NULL	Name of the column	G
COLSEQ	SMALLINT NOT NULL	Numeric position of the column in the key (the first position in the key is 1).	G
COLNO	SMALLINT NOT NULL	Numeric position of the column in the table on which the constraint is defined.	G
IBMREQD	CHAR(1) NOT NULL WITH DEFAULT 'N'	A value of Y indicates that the row was provided with the Db2 product code. For all other values, see Release dependency indicators . The value in this field is not a reliable indicator of release dependencies.	G
PERIOD	CHAR(1) NOT NULL WITH DEFAULT	Indicates whether the column is the start or end column for the BUSINESS_TIME period: B The column is the start of the period BUSINESS_TIME. C Column is the end of period BUSINESS_TIME with an exclusive end point. I Column is the end of period BUSINESS_TIME with an inclusive end point. blank Column is not used as either the start or the end of a BUSINESS_TIME period.	G

SYSKEYS catalog table

The SYSKEYS table contains one row for each column of an index key. The schema is SYSIBM.

Table 320. SYSIBM.SYSKEYS table column descriptions

Column name	Data type	Description	Use
IXNAME	VARCHAR(128) NOT NULL	Name of the index.	G
IXCREATOR	VARCHAR(128) NOT NULL	Schema or qualifier of the index.	G
COLNAME	VARCHAR(128) NOT NULL	Name of the column of the key.	G
COLNO	SMALLINT NOT NULL	Numeric position of the column in the table. For example, 4 (out of 10).	G

Table 320. SYSIBM.SYSKEYS table column descriptions (continued)

Column name	Data type	Description	Use
COLSEQ	SMALLINT NOT NULL	Numeric position of the column in the key for an index on columns. For example, 4 (out of 4). The value is meaningless for an expression-based index.	G
ORDERING	CHAR(1) NOT NULL	Order of the column in the key: blank Index is an expression-based index or the column is specified for the index using the INCLUDE clause A Ascending order D Descending order R Random order	G
IBMREQD	CHAR(1) NOT NULL	A value of Y indicates that the row was provided with the Db2 product code. For all other values, see Release dependency indicators . The value in this field is not a reliable indicator of release dependencies.	G
PERIOD	CHAR(1) NOT NULL WITH DEFAULT	Indicates whether the column is the start or end column for the BUSINESS_TIME period: B The column is the start of the period BUSINESS_TIME. C Column is the end of period BUSINESS_TIME with an exclusive end point. I Column is the end of period BUSINESS_TIME with an inclusive end point. blank Column is not used as either the start or the end of a BUSINESS_TIME period, or the index is not used as an enforcing index.	G
CREATEDTS	TIMESTAMP(12) NOT NULL WITH DEFAULT	Time when the CREATE statement was executed for the index.	G

Related concepts

[Index keys \(Db2 Administration Guide\)](#)

SYSKEYTARGETS catalog table

The SYSKEYTARGETS table contains one row for each key-target that is participating in an extended index definition. The schema is SYSIBM.

Table 321. SYSIBM.SYSKEYTARGETS table column descriptions

Column name	Data type	Description	Use
IXNAME	VARCHAR(128) NOT NULL	Name of the index.	G
IXSCHEMA	VARCHAR(128) NOT NULL	Qualifier of the index.	G
KEYSEQ	SMALLINT NOT NULL	Numeric position of the key-target in the index.	G
COLNO	SMALLINT NOT NULL	Numeric position of the column in the table if the expression is a single column. Otherwise the value is 0. For XML indexes, this field is also 0.	G
ORDERING	CHAR(1) NOT NULL	Order of the key: A Ascending	G
TYPESHEMA	VARCHAR(128) NOT NULL	Schema of the data type.	G
TYPENAME	VARCHAR(128) NOT NULL	Name of the data type.	G
DATATYPEID	INTEGER NOT NULL	The internal ID of the data type. The DATATYPEID value corresponds to one of the SQLTYPE values in “SQLTYPE and SQLLEN” on page 2322. However, the DATATYPEID value is not a reliable indicator of the nullability of the column. A column with an even DATATYPEID value might allow nulls, and a column with an odd DATATYPEID value might not allow nulls. To determine the nullability of the column, use the NULLS column value.	G
SOURCETYPEID	INTEGER NOT NULL	For a built-in data type, this column contains 0. For a distinct type, this column contains the internal ID of the built-in type on which the distinct type is based.	G

Table 321. SYSIBM.SYSKEYTARGETS table column descriptions (continued)

Column name	Data type	Description	Use
LENGTH	SMALLINT NOT NULL	<p>The length attribute of the key-target or its precision for a decimal key-target. The number does not include the internal prefixes that are used to record the actual length and null states, when applicable.</p> <p>data type value of the LENGTH column</p> <p>INTEGER 4</p> <p>SMALLINT 2</p> <p>FLOAT 4 or 8</p> <p>CHAR The length of the string</p> <p>VARCHAR The maximum length of the string</p> <p>DECIMAL The precision of the number</p> <p>GRAPHIC The number of DBCS characters</p> <p>VARGRAPHIC The maximum number of DBCS characters</p> <p>DATE 4</p> <p>TIME 3</p> <p>TIMESTAMP WITHOUT TIME ZONE The integral part of $((p+1)/2) + 7$ where p is the precision of the timestamp</p> <p>TIMESTAMP WITH TIME ZONE The integral part of $((p+1)/2) + 9$ where p is the precision of the timestamp</p> <p>BIGINT 8</p> <p>BINARY The length of the string</p> <p>VARBINARY The maximum length of the string</p> <p>DECFLOAT 8 or 16</p>	G

Table 321. SYSIBM.SYSKEYTARGETS table column descriptions (continued)

Column name	Data type	Description	Use
LENGTH2	INTEGER NOT NULL	The maximum length of the data that is retrieved from the column. Possible values include the following values: 0 Not a ROWID column 40 For a ROWID column, the length of the value that is returned	G
SCALE	SMALLINT NOT NULL	The scale of decimal data or number of fractional second digits of timestamp or timestamp with time zone data. Otherwise the value is 0. If the column is a timestamp type, the LENGTH is 10 and the SCALE is 0, the number of fractional second digits is 6.	G
NULLS	CHAR(1) NOT NULL	Whether the key can contain null values: N No Y Yes. Y also indicates that the index is an XML index.	G
CCSID	INTEGER NOT NULL	The CCSID of the key. CCSID contains 0 if the key is a non-character type key.	G
SUBTYPE	CHAR(1) NOT NULL	SUBTYPE applies to character keys only and indicated the subtype of the data: B BIT data M MIXED data S SBCS data blank non-character data	G
—	VARCHAR(512) NOT NULL FOR BIT DATA	Internal use only.	I
CREATEDTS	TIMESTAMP NOT NULL	The timestamp for when the key-target is created.	G
RELCREATED	CHAR(1) NOT NULL	The release of Db2 in which the key-target is created. See Release dependency indicators for values.	G

Table 321. SYSIBM.SYSKEYTARGETS table column descriptions (continued)

Column name	Data type	Description	Use
IBMREQD	CHAR(1) NOT NULL	A value of Y indicates that the row was provided with the Db2 product code. For all other values, see Release dependency indicators . The value in this field is not a reliable indicator of release dependencies. RELCREATED should be used instead.	G
DERIVED_FROM	VARCHAR(4000) NOT NULL	For an index on a scalar expression, DERIVED_FROM contains the text of the scalar expression that is used to generated the key-target value. For an XML index, this is the XML pattern that is used to generate the key-target value. Otherwise DERIVED_FROM contains an empty string.	G
STATSTIME	TIMESTAMP NOT NULL WITH DEFAULT	If RUNSTATS or another utility with inline statistics updated the statistics, the date and time when the last utility invocation updated the statistics. The default value is '0001-01-01-00.00.00.000000'. The default value indicates that statistics were not collected. This column can be updated.	G
CARDF	FLOAT NOT NULL WITH DEFAULT -1	The estimated number of distinct values for the key-target. The value is -2 if the index is a node ID index. For an XML value index, the statistic is collected for the second key target (the DOCID column). For all other key targets of the XML value index, a value of -2 is set.	S
HIGH2KEY	VARCHAR(2000) NOT NULL WITH DEFAULT FOR BIT DATA	The second highest key-value. HIGH2KEY is an updatable column.	S
LOW2KEY	VARCHAR(2000) NOT NULL WITH DEFAULT FOR BIT DATA	The second lowest key-value. LOW2KEY is an updatable column.	S
STATS_FORMAT	CHAR(1) NOT NULL WITH DEFAULT	The type of statistics that are gathered: N VARCHAR column statistical values are not padded blank Statistics have not been collects or VARCHAR column statistical values are padded STATS_FORMAT is an updatable column.	G

SYSKEYTARGETSTATS catalog table

The SYSKEYTARGETSTATS table contains partition statistics for selected key-targets. For each key-target, a row exists for each partition in the table.

Rows are inserted when RUNSTATS collects indexed key statistics or non-indexed key statistics for a partitioned table space. No row is inserted if the table space is nonpartitioned. Rows in this table can be inserted, updated, and deleted.

Important: Use care when issuing SQL statements or using tools to update statistics values in catalog tables. If such updates introduce invalid data, unpredictable results can occur, including abends for RUNSTATS and other utilities. If such problems occur, you can run the RUNSTATS utility and collect statistics at the table space level to resolve the problems, in most cases.

Table 322. SYSIBM.SYSKEYTARGETSTATS table column descriptions

Column name	Data type	Description	Use
IXSCHEMA	VARCHAR(128) NOT NULL	The qualifier of the index.	G
IXNAME	VARCHAR(128) NOT NULL	The name of the index.	G
KEYSEQ	SMALLINT NOT NULL	Numeric position of the key-target in the index.	G
HIGHKEY	VARCHAR(2000) NOT NULL WITH DEFAULT FOR BIT DATA	The highest key value.	S
HIGH2KEY	VARCHAR(2000) NOT NULL WITH DEFAULT FOR BIT DATA	The second highest key-value.	S
LOWKEY	VARCHAR(2000) NOT NULL WITH DEFAULT FOR BIT DATA	The lowest key value.	S
LOW2KEY	VARCHAR(2000) NOT NULL WITH DEFAULT FOR BIT DATA	The second lowest key-value.	S
PARTITION	SMALLINT NOT NULL	The partition number of the table space.	G
—	VARCHAR(1000) NOT NULL WITH DEFAULT FOR BIT DATA	Internal use only.	I
STATSTIME	TIMESTAMP NOT NULL WITH DEFAULT	If RUNSTATS or another utility with inline statistics updated the statistics, the date and time when the last utility invocation updated the statistics. The default value is '0001-01-01-00.00.00.000000'. The default value indicates that statistics were not collected. This column can be updated.	G

Table 322. SYSIBM.SYSKEYTARGETSTATS table column descriptions (continued)

Column name	Data type	Description	Use
IBMREQD	CHAR(1) NOT NULL	A value of Y indicates that the row was provided with the Db2 product code. For all other values, see Release dependency indicators . The value in this field is not a reliable indicator of release dependencies.	G
STATS_FORMAT	CHAR(1) NOT NULL WITH DEFAULT	The type of statistics that are gathered: N VARCHAR column statistical values are not padded blank Statistics have not been collected or VARCHAR column statistical values are padded	G
CARDF	FLOAT NOT NULL WITH DEFAULT -1	Number of distinct values for the key target.	S

SYSKEYTARGETS_HIST catalog table

The SYSKEYTARGETS_HIST table contains rows from the SYSKEYTARGETS table. The schema is SYSIBM.

Whenever rows are added or changed in SYSKEYTARGETS, the rows are also written to this table. Rows in this table can be inserted, updated, and deleted.

Table 323. SYSIBM.SYSKEYTARGETS_HIST table column descriptions

Column name	Data type	Description	Use
IXNAME	VARCHAR(128) NOT NULL	Name of the index.	G
IXSCHEMA	VARCHAR(128) NOT NULL	Qualifier of the index.	G
KEYSEQ	SMALLINT NOT NULL	Numeric position of the key-target in the index.	G
TYPESCHEMA	VARCHAR(128) NOT NULL	Schema of the data type.	G
TYPENAME	VARCHAR(128) NOT NULL	Name of the data type.	G

Table 323. SYSIBM.SYSKEYTARGETS_HIST table column descriptions (continued)

Column name	Data type	Description	Use
DATATYPEID	INTEGER NOT NULL	The internal ID of the data type. The DATATYPEID value corresponds to one of the SQLTYPE values in “SQLTYPE and SQLLEN” on page 2322. However, the DATATYPEID value is not a reliable indicator of the nullability of the column. A column with an even DATATYPEID value might allow nulls, and a column with an odd DATATYPEID value might not allow nulls. To determine the nullability of the column, use the NULLS column value.	G
SOURCETYPEID	INTEGER NOT NULL	For a built-in data type, this field contains 0. For a distinct type, this field contains the internal ID of the built-in type on which the distinct type is based.	G

Table 323. SYSIBM.SYSKEYTARGETS_HIST table column descriptions (continued)

Column name	Data type	Description	Use
LENGTH	SMALLINT NOT NULL	<p>The length attribute of the key-target or its precision for a decimal key-target. The number does not include the internal prefixes that are used to record the actual length and null states, when applicable.</p> <p>data type value of the LENGTH column</p> <p>INTEGER 4</p> <p>SMALLINT 2</p> <p>FLOAT 4 or 8</p> <p>CHAR The length of the string</p> <p>VARCHAR The maximum length of the string</p> <p>DECIMAL The precision of the number</p> <p>GRAPHIC The number of DBCS characters</p> <p>VARGRAPHIC The maximum number of DBCS characters</p> <p>DATE 4</p> <p>TIME 3</p> <p>TIMESTAMP WITHOUT TIME ZONE The integral part of $((p+1)/2) + 7$ where p is the precision of the timestamp</p> <p>TIMESTAMP WITH TIME ZONE The integral part of $((p+1)/2) + 9$ where p is the precision of the timestamp</p> <p>BIGINT 8</p> <p>BINARY The length of the string</p> <p>VARBINARY The maximum length of the string</p> <p>DECFLOAT 8 or 16</p>	G

Table 323. SYSIBM.SYSKEYTARGETS_HIST table column descriptions (continued)

Column name	Data type	Description	Use
LENGTH2	INTEGER NOT NULL	The maximum length of the data that is retrieved from the column. Possible values include the following values: 0 Not a ROWID column 40 For a ROWID column, the length of the value that is returned	G
SCALE	SMALLINT NOT NULL	The scale of decimal data or number of fractional second digits of timestamp or timestamp with time zone data. Otherwise the value is 0. If the column is a timestamp type, the LENGTH is 10 and the SCALE is 0, the number of fractional second digits is 6.	G
NULLS	CHAR(1) NOT NULL	Whether the key can contain null values: N No Y Yes	G
IBMREQD	CHAR(1) NOT NULL	A value of Y indicates that the row was provided with the Db2 product code. For all other values, see Release dependency indicators . The value in this field is not a reliable indicator of release dependencies.	G
STATSTIME	TIMESTAMP NOT NULL WITH DEFAULT	If RUNSTATS or another utility with inline statistics updated the statistics, the date and time when the last utility invocation updated the statistics. The default value is '0001-01-01-00.00.00.000000'. The default value indicates that statistics were not collected. This column can be updated.	G
CARDF	FLOAT NOT NULL WITH DEFAULT -1	The estimated number of distinct values for the key-target. The value is -2 if the index is a node ID index. For an XML value index, the statistic is collected for the second key target (the DOCID column). For all other key targets of the XML value index, a value of -2 is set.	G
HIGH2KEY	VARCHAR(2000) NOT NULL WITH DEFAULT FOR BIT DATA	The second highest key-value.	G
LOW2KEY	VARCHAR(2000) NOT NULL WITH DEFAULT FOR BIT DATA	The second lowest key-value.	G

Table 323. SYSIBM.SYSKEYTARGETS_HIST table column descriptions (continued)

Column name	Data type	Description	Use
STATS_FORMAT	CHAR(1) NOT NULL WITH DEFAULT	The type of statistics that are gathered: N VARCHAR column statistical values are not padded blank Statistics have not been collected or VARCHAR column statistical values are padded	G

SYSKEYTGTDIST catalog table

The SYSKEYTGTDIST table contains one or more rows for the first key-target of an extended index key. The schema is SYSIBM.

Rows in this table can be inserted, updated, and deleted.

Important: Use care when issuing SQL statements or using tools to update statistics values in catalog tables. If such updates introduce invalid data, unpredictable results can occur, including abends for RUNSTATS and other utilities. If such problems occur, you can run the RUNSTATS utility and collect statistics at the table space level to resolve the problems, in most cases.

Table 324. SYSIBM.SYSKEYTGTDIST table column descriptions

Column name	Data type	Description	Use
STATSTIME	TIMESTAMP NOT NULL WITH DEFAULT	If RUNSTATS or another utility with inline statistics updated the statistics, the date and time when the last utility invocation updated the statistics. The default value is '0001-01-01-00.00.00.000000'. The default value indicates that statistics were not collected. This column can be updated.	G
IBMREQD	CHAR(1) NOT NULL	A value of Y indicates that the row was provided with the Db2 product code. For all other values, see Release dependency indicators . The value in this field is not a reliable indicator of release dependencies.	G
IXSCHEMA	VARCHAR(128) NOT NULL	The qualifier of the index.	G
IXNAME	VARCHAR(128) NOT NULL	The name of the index.	G
KEYSEQ	SMALLINT NOT NULL	The numeric position of the key-target in the index.	G
KEYVALUE	VARCHAR(2000) NOT NULL WITH DEFAULT FOR BIT DATA	KEYVALUE contains the data of a frequently occurring value. If the value has a non-character data type, the data might not be printable.	S

Table 324. SYSIBM.SYSKEYTGTDIST table column descriptions (continued)

Column name	Data type	Description	Use
TYPE	CHAR(1) NOT NULL WITH DEFAULT 'F'	The type of statistics that are gathered: C Cardinality F Frequent value N Non-padded frequent value H Histogram statistics	G
CARDF	FLOAT NOT NULL WITH DEFAULT -1	When TYPE='C', CARDF contains the number of distinct values for the key group. When TYPE='H', CARDF contains the number of distinct values for the key group in a quantile indicated by QUANTILENO.	S
KEYGROUPKEYNO	VARCHAR(254) NOT NULL WITH DEFAULT FOR BIT DATA	KEYGROUPKEYNO contains a value that identifies the set of keys that are associated with the statistics. KEYGROUPKEYNO contains 0 if the statistics are only associated with a single key. If the statistics are associated with more than a single key, KEYGROUPKEYNO contains an array of SMALLINT key numbers with a dimension that is equal to the value in NUMKEYS.	S
NUMKEYS	SMALLINT NOT NULL WITH DEFAULT -1	The number of keys that are associated with the statistics. The value is always 1 when the object is an XML index.	G
FREQUENCYF	FLOAT NOT NULL WITH DEFAULT -1	When TYPE='F' or 'N', FREQUENCYF contains a value that indicates the percentage of entries in the index that have the value that is contained in the KEYVALUE column. When TYPE='H', FREQUENCYF contains a value that indicates the percentage of entries in the index that have a value that is in the range of the quantile that is indicated in the QUANTILENO column. To determine the percentage from the value of FREQUENCYF, multiply the value by 100. For example, a value of '1' indicates 100 percent. A value of '.153' indicates '15.3' percent.	G
QUANTILENO	SMALLINT NOT NULL WITH DEFAULT -1	QUANTILENO contains an ordinary sequence number of a quantile in the whole consecutive value range, from low to high.	G

Table 324. SYSIBM.SYSKEYTGTDIST table column descriptions (continued)

Column name	Data type	Description	Use
LOWVALUE	VARCHAR(2000) NOT NULL WITH DEFAULT FOR BIT DATA	When TYPE='H', LOWVALUE contains the lower bound for the quantile that is in QUANTILENO. LOWVALUE is not used if TYPE does not equal 'H'.	G
HIGHVALUE	VARCHAR(2000) NOT NULL WITH DEFAULT FOR BIT DATA	When TYPE='H', HIGHVALUE contains the upper bound for the quantile that is in QUANTILENO. HIGHVALUE is not used if TYPE does not equal 'H'.	G

SYSKEYTGTDISTSTATS catalog table

The SYSKEYTGTDISTSTATS table contains zero or more rows per partition for the first key-target of a data-partitioned secondary index.

Rows are inserted when RUNSTATS scans a data-partitioned secondary index. No row is inserted if the index is a secondary index. Rows in this table can be inserted, updated, and deleted.

Important: Use care when issuing SQL statements or using tools to update statistics values in catalog tables. If such updates introduce invalid data, unpredictable results can occur, including abends for RUNSTATS and other utilities. If such problems occur, you can run the RUNSTATS utility and collect statistics at the table space level to resolve the problems, in most cases.

Table 325. SYSIBM.SYSKEYTGTDISTSTATS table column descriptions

Column name	Data type	Description	Use
STATSTIME	TIMESTAMP NOT NULL WITH DEFAULT	If RUNSTATS or another utility with inline statistics updated the statistics, the date and time when the last utility invocation updated the statistics. The default value is '0001-01-01-00.00.00.000000'. The default value indicates that statistics were not collected. This column can be updated.	G
IBMREQD	CHAR(1) NOT NULL	A value of Y indicates that the row was provided with the Db2 product code. For all other values, see Release dependency indicators . The value in this field is not a reliable indicator of release dependencies.	G
PARTITION	SMALLINT NOT NULL	The partition number of the table space that contains the index in which the key is defined.	G
IXSCHEMA	VARCHAR(128) NOT NULL	The qualifier of the index.	G
IXNAME	VARCHAR(128) NOT NULL	The name of the index.	G
KEYSEQ	SMALLINT NOT NULL	Numeric position of the key-target in the index.	G

Table 325. SYSIBM.SYSKEYTGTDISTSTATS table column descriptions (continued)

Column name	Data type	Description	Use
KEYVALUE	VARCHAR(2000) NOT NULL WITH DEFAULT FOR BIT DATA	KEYVALUE contains the data of a frequently occurring value. If the value has a non-character data type, the data might not be printable.	S
TYPE	CHAR(1) NOT NULL WITH DEFAULT 'F'	The type of statistics that are gathered: C Cardinality F Frequent value N Non-padded frequent value H Histogram statistics	G
CARDF	FLOAT NOT NULL WITH DEFAULT -1	When TYPE='C', CARDF contains the number of distinct values for the key group. When TYPE='H', CARDF contains the number of distinct values for the key group in the quantile that is in QUANTILENO.	S
KEYGROUPKEYNO	VARCHAR(254) NOT NULL WITH DEFAULT	Identifies the set of keys that are associated with the statistics. If the statistics are only associated with a single key, KEYGROUPKEYNO contains a zero length value. Otherwise, KEYGROUPKEYNO contains an array of SMALLINT key numbers that have a dimension that is equal to the value in NUMKEYS.	S
NUMKEYS	SMALLINT NOT NULL WITH DEFAULT	Identifies the number of keys that are associated with the statistics.	G
FREQUENCYF	FLOAT NOT NULL WITH DEFAULT -1	When TYPE='F' or 'N', FREQUENCYF contains the percentage of entries in the index that have the value that is specified in KEYVALUE when the number of entries is multiplied by 100. For example, a value of '1' indicates 100 percent. A value of '.153' indicates 15.3 percent. When TYPE='H', FREQUENCYF contains the percentage of entries in the index that have a value that is in the range of the quantile that is indicated in QUANTILENO.	G
QUANTILENO	SMALLINT NOT NULL WITH DEFAULT -1	QUANTILENO contains an ordinary sequence number of a quantile in the whole consecutive value range, from low to high.	G
LOWVALUE	VARCHAR(2000) NOT NULL WITH DEFAULT FOR BIT DATA	When TYPE='H', LOWVALUE is the lower bound for the quantile that is indicated in QUANTILENO. LOWVALUE is not used if TYPE does not equal 'H'.	G

Table 325. SYSIBM.SYSKEYTGTDISTSTATS table column descriptions (continued)

Column name	Data type	Description	Use
HIGHVALUE	VARCHAR(2000) NOT NULL WITH DEFAULT FOR BIT DATA	When TYPE='H', HIGHVALUE is the upper bound for the quantile that is indicated in QUANTILENO. HIGHVALUE is not used if TYPE does not equal 'H'.	G
—	VARCHAR(1000)	Internal use only.	I

SYSKEYTGTDIST_HIST catalog table

The SYSKEYTGTDIST_HIST table contains rows from the SYSKEYTGTDIST table. Whenever rows are added or changed in SYSKEYTGTDIST, the rows are also written to this table.

Rows in this table can be inserted, updated, and deleted.

Table 326. SYSIBM.SYSKEYTGTDIST_HIST table column descriptions

Column name	Data type	Description	Use
STATSTIME	TIMESTAMP NOT NULL WITH DEFAULT	If RUNSTATS or another utility with inline statistics updated the statistics, the date and time when the last utility invocation updated the statistics. The default value is '0001-01-01-00.00.00.000000'. The default value indicates that statistics were not collected. This column can be updated.	G
IBMREQD	CHAR(1) NOT NULL	A value of Y indicates that the row was provided with the Db2 product code. For all other values, see Release dependency indicators . The value in this field is not a reliable indicator of release dependencies.	G
IXSCHEMA	VARCHAR(128) NOT NULL	The qualifier of the index.	G
IXNAME	VARCHAR(128) NOT NULL	The name of the index.	G
KEYSEQ	SMALLINT NOT NULL	The numeric position of the key-target in the index.	G
KEYVALUE	VARCHAR(2000) NOT NULL WITH DEFAULT FOR BIT DATA	KEYVALUE contains the data of a frequently occurring value. If the value has a non-character data type, the data might not be printable.	G

Table 326. SYSIBM.SYSKEYTGTDIST_HIST table column descriptions (continued)

Column name	Data type	Description	Use
TYPE	CHAR(1) NOT NULL WITH DEFAULT 'F'	The type of statistics that are gathered: C Cardinality F Frequent value N Non-padded frequent value H Histogram statistics	G
CARDF	FLOAT NOT NULL WITH DEFAULT -1	When TYPE='C', CARDF contains the number of distinct values for the key group. When TYPE='H', CARDF contains the number of distinct values for the key group in a quantile indicated by QUANTILENO.	G
KEYGROUPKEYNO	VARCHAR(254) NOT NULL WITH DEFAULT FOR BIT DATA	KEYGROUPKEYNO contains a value that identifies the set of keys that are associated with the statistics. KEYGROUPKEYNO contains 0 if the statistics are only associated with a single key. If the statistics are associated with more than a single key, KEYGROUPKEYNO contains an array of SMALLINT key numbers with a dimension that is equal to the value in NUMKEYS.	G
NUMKEYS	SMALLINT NOT NULL WITH DEFAULT -1	The number of keys that are associated with the statistics.	G
FREQUENCYF	FLOAT NOT NULL WITH DEFAULT -1	When TYPE='F' or 'N', FREQUENCYF contains the percentage of entries in the index that have the value that is specified in KEYVALUE when the number of entries is multiplied by 100. For example, a value of '1' indicates 100 percent. A value of '.153' indicates 15.3 percent. When TYPE='H', FREQUENCYF contains the percentage of entries in the index that have a value that is in the range of the quantile that is indicated in QUANTILENO.	G
QUANTILENO	SMALLINT NOT NULL WITH DEFAULT -1	QUANTILENO contains an ordinary sequence number of a quantile in the whole consecutive value range, from low to high.	G
LOWVALUE	VARCHAR(2000) NOT NULL WITH DEFAULT FOR BIT DATA	When TYPE='H', LOWVALUE contains the lower bound for the quantile that is in QUANTILENO. LOWVALUE is not used if TYPE does not equal 'H'.	G

Table 326. SYSIBM.SYSKEYTGTDIST_HIST table column descriptions (continued)

Column name	Data type	Description	Use
HIGHVALUE	VARCHAR(2000) NOT NULL WITH DEFAULT FOR BIT DATA	When TYPE='H', HIGHVALUE contains the upper bound for the quantile that is in QUANTILENO. HIGHVALUE is not used if TYPE does not equal 'H'.	G

SYSLEVELUPDATES catalog table

The SYSLEVELUPDATES table contains information about the catalog level and function level of the Db2 subsystem or data sharing group. The schema is SYSIBM.

Column name	Data type	Description	Use
FUNCTION_LVL	VARCHAR(10)	Function level in effect when this record was inserted.	G
PREV_FUNCTION_LVL	VARCHAR(10)	Previous function level.	G
HIGH_FUNCTION_LVL	VARCHAR(10)	Highest activated function level.	G
CATALOG_LVL	VARCHAR(10)	The catalog level.	G
OPERATION_TYPE	CHAR(1)	Type of operation: 'C' Catalog level change. 'F' Function level change. 'M' Code level change.	G
EFFECTIVE_TIME	TIMESTAMP(12)	Time when the operation completed.	G
EFFECTIVE_LRSN		RBA (or LRSN for data sharing) depicting the time that an operation completed.	G
OPERATION_TEXT	VARCHAR(256)	The text of the operation.	G
GROUP_MEMBER	VARCHAR(24)	Name of the group member on which the operation was run.	G

Related concepts

[Function levels and related levels in Db2 12 \(Db2 for z/OS What's New?\)](#)

Related tasks

[Activating Db2 12 function levels \(Db2 for z/OS What's New?\)](#)

Related information

[DSNG014I \(Db2 Messages\)](#)

SYSLOBSTATS catalog table

The SYSLOBSTATS table contains one row for each LOB table space. The schema is SYSIBM.

Table 327. SYSIBM.SYSLOBSTATS table column descriptions

Column name	Data type	Description	Use
STATSTIME	TIMESTAMP NOT NULL	If RUNSTATS or another utility with inline statistics updated the statistics, the date and time when the last utility invocation updated the statistics. The default value is '0001-01-01-00.00.00.000000'. The default value indicates that statistics were not collected. This column can be updated.	G
AVGSIZE	INTEGER NOT NULL	Average size of a LOB, measured in bytes, in the LOB table space.	S
FREESPACE	INTEGER NOT NULL	Number of kilobytes of available space in the LOB table space.	S
ORGRATIO	DECIMAL(5,2) NOT NULL	The percentage of organization in the LOB table space. A value of '100' indicates perfect organization of the LOB table space. A value of '1' indicates that the LOB table space is disorganized. A value of '0' indicates that the LOB table space is totally disorganized.	S
DBNAME	VARCHAR(24) NOT NULL	Name of the database that contains the LOB table space named in NAME.	G
NAME	VARCHAR(24) NOT NULL	Name of the LOB table space.	G
IBMREQD	CHAR(1) NOT NULL	A value of Y indicates that the row was provided with the Db2 product code. For all other values, see Release dependency indicators . The value in this field is not a reliable indicator of release dependencies.	G

SYSLOBSTATS_HIST catalog table

The SYSLOBSTATS_HIST table contains rows from SYSIBM.SYSLOBSTATS. The schema is SYSIBM.

Rows are added or changed in this table when RUNSTATS collects history statistics. Rows in this table can also be inserted, updated, and deleted.

Table 328. SYSIBM.SYSLOBSTATS_HIST table column descriptions

Column name	Data type	Description	Use
STATSTIME	TIMESTAMP NOT NULL	If RUNSTATS or another utility with inline statistics updated the statistics, the date and time when the last utility invocation updated the statistics. The default value is '0001-01-01-00.00.00.000000'. The default value indicates that statistics were not collected. This column can be updated.	G
FREESPACE	INTEGER NOT NULL	Number of pages of free space in the LOB table space.	S
ORGRATIO	DECIMAL(5,2) NOT NULL	The percentage of organization in the LOB table space. A S value of '100' indicates perfect organization of the LOB table space. A value of '1' indicates that the LOB table space is disorganized. A value of '0' indicates that the LOB table space is totally disorganized.	S
DBNAME	VARCHAR(24) NOT NULL	Name of the database that contains the LOB table space named in NAME.	G
NAME	VARCHAR(24) NOT NULL	Name of the LOB table space.	G
IBMREQD	CHAR(1) NOT NULL WITH DEFAULT 'N'	A value of Y indicates that the row was provided with the Db2 product code. For all other values, see Release dependency indicators . The value in this field is not a reliable indicator of release dependencies.	G

SYSOBJROLEDEP catalog table

The SYSOBJROLEDEP table lists the dependent objects for each role. The schema is SYSIBM.

Table 329. SYSIBM.SYSOBJROLEDEP table column descriptions

Column name	Data type	Description	Use
DEFINER	VARCHAR(128) NOT NULL	The authorization ID or role that created the object.	G
DEFINERTYPE	CHAR(1) NOT NULL	The type of definer: L Role blank Authorization ID	G
ROLENAME	VARCHAR(128) NOT NULL	Name of the role on which there is a dependency.	G

Table 329. SYSIBM.SYSOBJROLEDEP table column descriptions (continued)

Column name	Data type	Description	Use
DSHEMA	VARCHAR(128) NOT NULL	Name of the schema of the dependent object.	G
DNAME	VARCHAR(762) NOT NULL	Name of the dependent object.	G
DTYPE	CHAR(1) NOT NULL	The type of the dependent object in DNAME: B Trigger D Database E Distinct type F User-defined function H Global variable I Index J JAR file L Role M Materialized query table N Trusted context O Stored procedure Q Sequence R Table space S Storage group T Table V View X Row permission Y Column mask 0 (zero) Alias	G

Table 329. SYSIBM.SYSOBJROLEDEP table column descriptions (continued)

Column name	Data type	Description	Use
IBMREQD	CHAR(1) NOT NULL	A value of Y indicates that the row was provided with the Db2 product code. For all other values, see Release dependency indicators . The value in this field is not a reliable indicator of release dependencies.	G

SYSPACKAGE catalog table

The SYSPACKAGE table contains a row for every package. The schema is SYSIBM.

Column name	Data type	Description	Use
LOCATION	VARCHAR(128) NOT NULL	Always contains blanks	S
COLLID	VARCHAR(128) NOT NULL	Name of the package collection. For a trigger package, it is the schema name of the trigger.	G
NAME	VARCHAR(128) NOT NULL	Name of the package.	G
CONTOKEN	CHAR(8) NOT NULL FOR BIT DATA	Consistency token for the package. For a package derived from a Db2 DBRM, it is one of the following values: <ul style="list-style-type: none"> The "level" as specified by the LEVEL option when the package's program was precompiled The timestamp indicating when the package's program was precompiled, in an internal format. 	S
OWNER	VARCHAR(128) NOT NULL	Authorization ID of the package owner. For a trigger package, the value is the authorization ID of the owner of the trigger, which is set to the current authorization ID (the plan or package owner for static CREATE TRIGGER statement; the CURRENT SQLID for a dynamic CREATE TRIGGER statement).	G
CREATOR	VARCHAR(128) NOT NULL	Authorization ID of the creator of the package. The creator is the authorization ID under which the package was bound or rebound. For a trigger package, the value is determined differently. For dynamic SQL, it is the primary authorization ID of the user who issued the CREATE TRIGGER statement. For static SQL, it is the authorization ID of the plan or package owner.	G

⁴⁰ Packages are divided into *sections*. The base section of the package must be in the EDM pool during the entire time the package is executing. Other sections of the package, corresponding roughly to sets of related SQL statements, are brought into the pool as needed.

⁴¹ The value is not updated instantly. There might be a delay of several days before the value is updated.

Column name	Data type	Description	Use
TIMESTAMP	TIMESTAMP NOT NULL	Timestamp indicating when the package was created.	G
BINDTIME	TIMESTAMP NOT NULL	Timestamp indicating when the package was last bound.	G
QUALIFIER	VARCHAR(128) NOT NULL	Implicit qualifier for the unqualified table, view, index, and alias names in the static SQL statements of the package.	G
PKSIZE	INTEGER NOT NULL	Size of the base section ⁴⁰ of the package, in bytes.	G
AVGSIZE	INTEGER NOT NULL	Average size, in bytes, of those sections ⁴⁰ of the plan that contain SQL statements processed at bind time.	G
SYSENTRIES	SMALLINT NOT NULL	Number of enabled or disabled entries for this package in SYSIBM.SYSPKSYSTEM. A value of 0 if all types of connections are enabled.	G
VALID	CHAR(1) NOT NULL	Whether the package is valid: A An ALTER statement changed the description of the table or base table of a view referred to by the package. The changes do not invalidate the package. However, a rebind might be required for the package to pick up the changes from the ALTER statement. H An ALTER TABLE statement changed the description of the table or base table of a view referred to by the package. For releases of Db2 prior to Version 5, the change invalidates the package. N No Y Yes	G
OPERATIVE	CHAR(1) NOT NULL	Whether the package can be allocated: N A package with package-level dependency cannot be allocated. An explicit BIND or REBIND is required before the package can be allocated. Y Yes	G

Column name	Data type	Description	Use
VALIDATE	CHAR(1) NOT NULL	Whether validity checking can be deferred until run time: B All checking must be performed at bind time. R Validation is done at run time for tables, views, and privileges that do not exist at bind time.	G
ISOLATION	CHAR(1) NOT NULL	Isolation level when the package was last bound or rebound R RR (repeatable read) S CS (cursor stability) T RS (read stability) U UR (uncommitted read) blank Not specified, and therefore at the level specified for the plan executing the package	G
RELEASE	CHAR(1) NOT NULL	The value used for RELEASE when the package was last bound or rebound: C Value used was COMMIT. D Value used was DEALLOCATE. I The local package is inheriting the value from the plan blank Not specified, and therefore the value specified for the plan executing the package.	G
EXPLAIN	CHAR(1) NOT NULL	EXPLAIN option specified for the package; that is, whether information on the package's statements was added to the owner of the PLAN_TABLE table: N No Y Yes	G
QUOTE	CHAR(1) NOT NULL	SQL string delimiter for SQL statements in the package: N Apostrophe Y Quotation mark	G

Column name	Data type	Description	Use
COMMA	CHAR(1) NOT NULL	Decimal point representation for SQL statements in package: N Period Y Comma	G
HOSTLANG	CHAR(1) NOT NULL	Host language, or a value set by the program preparation process: B Assembler language C OS/VS COBOL D C F Fortran J Java P PL/I R REST 2 VS COBOL II or IBM COBOL Release 1 (formerly called COBOL/370) 3 IBM COBOL (Release 2 or subsequent releases) 4 C++ blank For remotely bound packages, trigger packages (TYPE='T' or '1'), SQL procedure packages (TYPE='N'), or non-inline SQL scalar function packages (TYPE='F').	G
CHARSET	CHAR(1) NOT NULL	Indicates whether the system CCSID for SBCS data was 290 (Katakana) when the program was precompiled: K Yes A No	G

Column name	Data type	Description	Use
MIXED	CHAR(1) NOT NULL	Indicates if mixed data was in effect when the package's program was precompiled (for more on when mixed data is in effect, see "Character strings" on page 102): N No Y Yes	G
DEC31	CHAR(1) NOT NULL	Indicates whether DEC31 was in effect when the package's program was precompiled (for more on when DEC31 is in effect, see "Arithmetic with two decimal operands" on page 251): N No Y Yes	G
DEFERPREP	CHAR(1) NOT NULL	Indicates the CURRENTDATA option when the package was bound or rebound: A Data currency is required for all cursors. Inhibit blocking for all cursors. B Data currency is not required for ambiguous cursors. C Data currency is required for ambiguous cursors. blank The package was created before the CURRENTDATA option was available.	G
SQLERROR	CHAR(1) NOT NULL	Indicates the SQLERROR option on the most recent subcommand that bound or rebound the package: C CONTINUE N NOPACKAGE	G

Column name	Data type	Description	Use
REMOTE	CHAR(1) NOT NULL	<p>Source of the package:</p> <p>C Package was created by BIND COPY.</p> <p>D Package was created by BIND COPY with the OPTIONS(COMMAND) option.</p> <p>K The package was copied from a package that was originally bound on behalf of a remote requester.</p> <p>L The package was copied with the OPTIONS(COMMAND) option from a package that was originally bound on behalf of a remote requester.</p> <p>N Package was locally bound from a DBRM.</p> <p>Y Package was bound on behalf of a remote requester.</p>	G
PCTIMESTAMP	TIMESTAMP NOT NULL	Date and time the application program was precompiled, or '0001-01-01-00.00.00.000000' if the LEVEL precompiler option was used, or if the package came from a non-Db2 location.	G
IBMREQD	CHAR(1) NOT NULL	<p>A value of Y indicates that the row was provided with the Db2 product code. For all other values, see Release dependency indicators.</p> <p>The value in this field is not a reliable indicator of release dependencies. RELBOUND should be used instead.</p>	G
VERSION	VARCHAR(122) NOT NULL	<p>Version identifier for the package.</p> <p>The value is an empty string for:</p> <ul style="list-style-type: none"> A package for a basic trigger (TYPE='T'). A package for an application that was precompiled without SQL processing option VERSION, or was precompiled with an empty string for the VERSION value. (TYPE=blank). 	G

Column name	Data type	Description	Use
PDSNAME	VARCHAR(132) NOT NULL	<p>For a locally bound package, the name of the PDS (library) in which the package's DBRM is a member. For a locally copied package, the value in SYSPACKAGE.PDSNAME for the source package. Otherwise, the product signature of the bind requester followed by one of the following:</p> <ul style="list-style-type: none"> • For Db2 for z/OS remote requesters, the requester's location name, or IP address, or LU name enclosed in angle brackets (for example, "<LUSQLDS>"). • For non-Db2 for z/OS remote requesters, the requester's IP address or LU name enclosed in angle brackets. 	G
DEGREE	CHAR(3) NOT NULL WITH DEFAULT	<p>The DEGREE option used when the package was last bound:</p> <p>ANY DEGREE(ANY)</p> <p>1 or blank DEGREE(1). Blank if the package was migrated.</p>	G
GROUP_MEMBER	VARCHAR(24) NOT NULL WITH DEFAULT	<p>The Db2 data sharing member name of the Db2 subsystem that performed the most recent bind. This column is blank if the Db2 subsystem was not in a Db2 data sharing environment when the bind was performed.</p>	G

Column name	Data type	Description	Use
DYNAMICRULES	CHAR(1) NOT NULL WITH DEFAULT	<p>The DYNAMICRULES option used when the package was last bound: ^G</p> <p>B BIND. Dynamic SQL statements are executed with DYNAMICRULES bind behavior.</p> <p>D DEFINEBIND. When the package is run under an active stored procedure or user-defined function, dynamic SQL statements in the package are executed with DYNAMICRULES define behavior.</p> <p>When the package is not run under an active stored procedure or user-defined function, dynamic SQL statements in the package are executed with DYNAMICRULES bind behavior.</p> <p>E DEFINERUN. When the package is run under an active stored procedure or user-defined function, dynamic SQL statements in the package are executed with DYNAMICRULES define behavior.</p> <p>When the package is not run under an active stored procedure or user-defined function, dynamic SQL statements in the package are executed with DYNAMICRULES run behavior.</p> <p>H INVOKEBIND. When the package is run under an active stored procedure or user-defined function, dynamic SQL statements in the package are executed with DYNAMICRULES invoke behavior.</p> <p>When the package is not run under an active stored procedure or user-defined function, dynamic SQL statements in the package are executed with DYNAMICRULES bind behavior.</p>	

Column name	Data type	Description	Use
DYNAMICRULES (continued)		<p>I INVOKERUN. When the package is run under an active stored procedure or user-defined function, dynamic SQL statements in the package are executed with DYNAMICRULES invoke behavior.</p> <p>When the package is not run under an active stored procedure or user-defined function, dynamic SQL statements in the package are executed with DYNAMICRULES run behavior.</p> <p>R RUN. Dynamic SQL statements are executed with DYNAMICRULES run behavior.</p> <p>blank DYNAMICRULES is not specified for the package. The package uses the DYNAMICRULES value of the plan to which the package is appended at execution time.</p> <p>For a description of the DYNAMICRULES behaviors, see “Authorization IDs and dynamic SQL” on page 94.</p>	
REOPTVAR	CHAR(1) NOT NULL WITH DEFAULT 'N'	<p>Whether the access path is determined again at execution time using input variable values:</p> <p>A Bind option REOPT(AUTO) indicates that the access path is determined multiple times at execution time depending on the parameter value.</p> <p>N Bind option REOPT(NONE) indicates that the access path is determined at bind time.</p> <p>Y Bind option REOPT(ALWAYS) indicates that the access path is determined at execution time for SQL statements with variable values.</p> <p>1 Bind option REOPT(ONCE) indicates that the access path is determined only once at execution time, using the first set of input variable values, regardless of how many times the same statement is executed.</p>	G

Column name	Data type	Description	Use
DEFERPREPARE	CHAR(1) NOT NULL WITH DEFAULT	<p>Whether PREPARE processing is deferred until OPEN is executed:</p> <p>N Bind option NODEFER(PREPARE) indicates that PREPARE processing is not deferred until OPEN is executed.</p> <p>Y Bind option DEFER(PREPARE) indicates that PREPARE processing is deferred until OPEN is executed.</p> <p>I The local package is inheriting the value from the plan</p> <p>blank Blank for a trigger package. Otherwise, the bind option was not specified for the package and is inherited from the plan.</p>	G
KEEPDYNAMIC	CHAR(1) NOT NULL WITH DEFAULT 'N'	<p>Whether prepared dynamic statements are to be purged at each commit point:</p> <p>N The bind option is KEEPDYNAMIC(NO). Prepared dynamic SQL statements are destroyed at each commit point or rollback operation.</p> <p>Y The bind option is KEEPDYNAMIC(YES). Prepared dynamic SQL statements are kept past each commit point or rollback operation.</p>	G
PATHSCHEMAS	VARCHAR(2048) NOT NULL WITH DEFAULT	SQL path specified on the BIND or REBIND command that bound the package. The path is used to resolve unqualified data type, function, and stored procedure names used in certain contexts. If the PATH bind option was not specified, the value in the column is a zero length string; however, Db2 uses the default SQL path.	G

Column name	Data type	Description	Use
TYPE	CHAR(1) NOT NULL WITH DEFAULT	Type of package. Identifies how the package is created: F A CREATE FUNCTION or ALTER FUNCTION statement, or a BIND PACKAGE DEPLOY command created the package, and this package is a compiled SQL scalar function package. N A CREATE PROCEDURE or ALTER PROCEDURE statement, or BIND PACKAGE DEPLOY command created the package, and this package is a native SQL routine package. T A CREATE TRIGGER or ALTER TRIGGER statement for a basic trigger created the package. blank BIND PACKAGE command created the package. 1 A CREATE TRIGGER or ALTER TRIGGER statement for an advanced trigger created the package.	G
DBPROTOCOL	CHAR(1) NOT NULL WITH DEFAULT 'D'	Whether remote access for SQL is implemented with DRDA access or DRDA access with the capability for package-based continuous block fetch: D DRDA C DRDA access with package-based continuous block fetch enabled.	G
FUNCTIONTS	TIMESTAMP NOT NULL WITH DEFAULT	Timestamp when the function was resolved. This value is set by the BIND and REBIND commands, but not by automatic rebinds (autobind).	G
OPTHINT	VARCHAR(128) NOT NULL WITH DEFAULT	Value of the OPTHINT bind option. Identifies rows in owner.PLAN_TABLE that are to be used as input to Db2. Refer to the ACCESSPATH column in the “SYSPACKSTMT catalog table” on page 2558 for information about which statements are using the specified hints.	G

Column name	Data type	Description	Use
ENCODING_CCSID	INTEGER NOT NULL WITH DEFAULT	The CCSID corresponding to the encoding scheme or CCSID as specified for the bind option ENCODING. The Encoding Scheme specified on the bind command: ccsid The specified or derived CCSID. 0 The default CCSID as specified on panel DSNTIPF at installation time. Used when the package was bound prior to Version 7.	G
IMMEDWRITE	CHAR(1) NOT NULL WITH DEFAULT	Indicates when writes of updated group buffer pool dependent pages are to be done. This option is only applicable for data sharing environments. I The local package is inheriting the value from the plan N Bind option IMMEDIATEWRITE(NO) indicates normal write activity is done. Y Bind option IMMEDIATEWRITE(YES) indicates that immediate writes are done for updated group buffer pool dependent pages. 1 Bind option IMMEDIATEWRITE(PH1) indicates that updated group buffer pool dependent pages are written at or before phase 1 commit. blank A migrated package.	G
RELBOUND	CHAR(1) NOT NULL WITH DEFAULT	The release when the package was bound or rebound. blank Bound prior to Version 7 For all other values, see Release dependency indicators	G
CATENCODE	CHAR(1)	Not used.	N
REMARKS	VARCHAR(550) NOT NULL WITH DEFAULT	A character string provided by the user with the COMMENT statement.	G
OWNERTYPE	CHAR(1) NOT NULL WITH DEFAULT	Indicates the type of owner blank Authorization ID L Role	G

Column name	Data type	Description	Use
ROUNDING	CHAR(1) NOT NULL WITH DEFAULT	<p>The ROUNDING option used when the package was last bound:</p> <p>C ROUND_CEILING</p> <p>D ROUND_DOWN</p> <p>F ROUND_FLOOR</p> <p>G ROUND_HALF_DOWN</p> <p>E ROUND_HALF_EVEN</p> <p>H ROUND_HALF_UP</p> <p>U ROUND_UP</p> <p>blank The package created in a Db2 release prior to Version 9.</p>	G
DISTRIBUTE	CHAR(1) NOT NULL WITH DEFAULT 'N'	<p>Determines if Db2 should gather location names from SQL statements, and create remote packages for the user (This only has effect during local bind):</p> <p>A Db2 will collect remote location names from SQL statements during local bind, and automatically create remote packages at those sites. The site names are gathered from object names in static SQL statements and literals on CONNECT statements. The sites at which the package is remotely bound can be determined by the location (BTYPE='X') records in SYSIBM.SYSPACKDEP for this package.</p> <p>L Db2 will automatically create remote packages at the sites specified in the list of location-names. The sites at which the package is remotely bound can be determined by the location (BTYPE='X') records in SYSIBM.SYSPACKDEP for this package.</p>	G
LASTUSED	DATE NOT NULL WITH DEFAULT	<p>The last date that the package was used. The LASTUSED value is set to '0001-01-01' when the package is created, and the value is updated whenever the package is used.⁴¹ The following commands preserve the existing value:</p> <ul style="list-style-type: none"> • BIND REPLACE of the same package version • REBIND 	G

Column name	Data type	Description	Use
CONCUR_ACC_RES	CHAR(1) NOT NULL	Indicates the CONCURRENTACCESSRESOLUTION option when the package was bound or rebound: blank Not specified U USECURRENTLYCOMMITTED W WAITFOROUTCOME	G
EXTENDEDINDICATOR	CHAR(1) NOT NULL WITH DEFAULT	The value of the EXTENDEDINDICATOR bind option: blank Not specified N EXTENDEDINDICATOR NO Y EXTENDEDINDICATOR YES	G
COPYID	INTEGER NOT NULL	The current copy of the package.	G
PLANMGMT	CHAR(1) NOT NULL WITH DEFAULT	The value of the PLANMGMT bind option: E PLANMGMT EXTENDED B PLANMGMT BASIC blank PLANMGMT OFF	G
PLANMGMTSCOPE	CHAR(1) NOT NULL WITH DEFAULT	The value of the PLANMGMTSCOPE bind option: S PLANMGMTSCOPE STATIC	G
APREUSE	CHAR(1) NOT NULL WITH DEFAULT	The value of the APREUSE bind option at the conclusion of a successful bind operation. N NO or NONE: Access paths were not reused. W WARN: Db2 attempted to reuse access paths. If an access path could not be reused, Db2 generated a new access path. E ERROR: Access paths were successfully reused. No error condition prevented Db2 from reusing access paths.	G

Column name	Data type	Description	Use
APRETAINDUP	CHAR(1) NOT NULL WITH DEFAULT	<p>The value of the APRETAINDUP bind option:</p> <p>Y APRETAINDUP YES specified. All copies were retained.</p> <p>0 APRETAINDUP NO specified; however, the previous or original package copy is still retained due to access path differences.</p> <p>1 APRETAINDUP NO specified, and the previous package copy is not retained as the access paths are identical to the current copy.</p> <p>2 APRETAINDUP NO specified, and the previous and original package copies are not retained as the access paths are identical to the current copy.</p>	G
SYSTIMESENSITIVE	CHAR(1) NOT NULL WITH DEFAULT 'N'	<p>The value of the SYSTIMESENSITIVE bind option:</p> <p>Y References to system-period temporal tables are affected by the value of the CURRENT TEMPORAL SYSTEM_TIME special register.</p> <p>N References to system-period temporal tables are not affected by the value of the CURRENT TEMPORAL SYSTEM_TIME special register.</p>	G
RECORDTEMPORALHIST	CHAR(1) NOT NULL WITH DEFAULT 'Y'	Not used.	N
BUSTIMESENSITIVE	CHAR(1) NOT NULL WITH DEFAULT 'N'	<p>The value of the BUSTIMESENSITIVE bind option:</p> <p>Y References to application-period temporal tables are affected by the value of the CURRENT TEMPORAL BUSINESS_TIME special register.</p> <p>N References to application-period temporal tables are not affected by the value of the CURRENT TEMPORAL BUSINESS_TIME special register.</p>	G

Column name	Data type	Description	Use
APPLCOMPAT	VARCHAR(10) NOT NULL WITH DEFAULT	<p>The application compatibility level of the package, or blank if the package was bound before Db2 11, or not determined.</p> <p>VvvRrMmmm</p> <p>Compatibility with the behavior of the identified Db2 function level. For example, V12R1M510 specifies compatibility with the highest available Db2 12 function level. The equivalent function level or higher must be activated.</p> <p>For the new capabilities that become available in each application compatibility level, see:</p> <ul style="list-style-type: none"> • SQL changes in Db2 13 application compatibility levels • SQL changes in Db2 12 application compatibility levels <p>Tip: Extra program preparation steps might be required to increase the application compatibility level for applications that use data server clients or drivers to access Db2 for z/OS. For more information, see Setting application compatibility levels for data server clients and drivers (Db2 Application programming and SQL).</p> <p>V12R1</p> <p>Compatibility with the behavior of Db2 12 function level 500. This value has the same result as specifying V12R1M500.</p> <p>V11R1</p> <p>Compatibility with the behavior of Db2 11 new-function mode. After migration to Db2 12, this value has the same result as specifying V12R1M100. For more information, see V11R1 application compatibility level (Db2 Application programming and SQL)</p> <p>V10R1</p> <p>Compatibility with the behavior of DB2 10 new-function mode. For more information, see V10R1 application compatibility level (Db2 Application programming and SQL).</p>	G

Column name	Data type	Description	Use
ARCHIVESENSITIVE	CHAR(1) NOT NULL WITH DEFAULT 'N'	The value of the ARCHIVESENSITIVE bind option. Y References to archive-enabled tables are affected by the value of the SYSIBMADM.GET_ARCHIVE built-in global variable. Y is the default value. N References to archive-enabled tables are not affected by the value of the SYSIBMADM.GET_ARCHIVE built-in global variable.	G
EXTSEQNO	INTEGER NOT NULL WITH DEFAULT 0	Internal use only.	I
DESCSTAT	CHAR(1) NOT NULL WITH DEFAULT	The value of the DESCSTAT bind option. Y The Db2 database manager generates a DESCRIBE SQLDA at bind time so that DESCRIBE requests for static SQL can be satisfied during execution. N The Db2 database manager does not generate a DESCRIBE SQLDA at bind time for static SQL statements. blank The package was bound before Db2 11, or not determined.	G
ORIGIN	CHAR(1) NOT NULL WITH DEFAULT	The origin of the EXPLAIN records: A Automatic bind B BIND command G Implicit automatic regeneration of the SQL routine or trigger for changed options, or an explicit ALTER REGENERATE of the SQL routine or trigger for the package I Implicit automatic regeneration of the SQL routine or trigger for the package because of fallback, coexistence, or deployment to a different release where the routines or triggers are incompatible. R REBIND command blank The row existed before Db2 12. This is the default value.	G

Column name	Data type	Description	Use
APREUSE_NO_FL	VARCHAR(10) NOT NULL WITH DEFAULT	The function level when the package was bound with APREUSE(NO), or blank if the package was bound before Db2 12, or not determined. This is the default value.	G
APREUSE_NO_TS	TIMESTAMP NOT NULL WITH DEFAULT	The bind time when the package was bound with APREUSE(NO): 0001-01-01-00.00.00.000000 The package was bound before Db2 12. This is the default value.	G
CONC_STMT	CHAR(1) NOT NULL WITH DEFAULT 'N'	Whether statement concentration is enabled: N No. This is the default value. Y Yes	G
FUNCTION_LVL	VARCHAR(10) NOT NULL WITH DEFAULT	The function level of the package, or blank if the package was bound before Db2 12, or not determined.	G

SYSPACKAUTH catalog table

The SYSPACKAUTH table records the privileges that are held by users over packages. The schema is SYSIBM.

Column name	Data type	Description	Use
GRANTOR	VARCHAR(128) NOT NULL	Authorization ID of the user who granted the privilege. Could also be PUBLIC.	G
GRANTEE	VARCHAR(128) NOT NULL	Authorization ID of the user who holds the privileges, the name of a plan that uses the privileges or PUBLIC for a grant to PUBLIC.	G
LOCATION	VARCHAR(128) NOT NULL	Always contains blanks	S
COLLID	VARCHAR(128) NOT NULL	Collection name for the package or packages on which the privilege was granted.	G
NAME	VARCHAR(128) NOT NULL	Name of the package on which the privileges are held. An asterisk (*) if the privileges are held on all packages in a collection.	G
CONTOKEN	CHAR(8) NOT NULL FOR BIT DATA	Consistency token for the package, as stored in the SYSPACKAGE catalog table. The value can also be blank. Db2 does not use this value to determine authorization for package operations such as bind, copy, or execution.	S

Column name	Data type	Description	Use
TIMESTAMP	TIMESTAMP NOT NULL	Timestamp indicating when the privilege was granted.	G
GRANTEETYPE	CHAR(1) NOT NULL	Type of grantee: blank An authorization ID L Role P An application plan	G
AUTHHOWGOT	CHAR(1) NOT NULL	Authorization level of the user from whom the privileges were received. This authorization level is not necessarily the highest authorization level of the grantor. blank Not applicable A PACKADM (on collection *) C DBCTRL D DBADM E SECADM G ACCESSCTRL L SYSCTRL M DBMAINT P PACKADM (on a specific collection) S SYSADM T DATAACCESS	G
BINDAUTH	CHAR(1) NOT NULL	Whether GRANTEE can use the BIND and REBIND subcommands on the package: blank Privilege is not held G Privilege is held with the GRANT option Y Privilege is held without the GRANT option	G

Column name	Data type	Description	Use
COPYAUTH	CHAR(1) NOT NULL	Whether GRANTEE can COPY the package: blank Privilege is not held G Privilege is held with the GRANT option Y Privilege is held without the GRANT option	G
EXECUTEAUTH	CHAR(1) NOT NULL	Whether GRANTEE can execute the package: blank Privilege is not held G Privilege is held with the GRANT option Y Privilege is held without the GRANT option	G
IBMREQD	CHAR(1) NOT NULL	A value of Y indicates that the row was provided with the Db2 product code. For all other values, see Release dependency indicators . The value in this field is not a reliable indicator of release dependencies.	G
GRANTORTYPE	CHAR(1) NOT NULL WITH DEFAULT	Indicates the type of grantor: blank Authorization ID L Role	G
SYS_START	TIMESTAMP(12) NOT NULL GENERATED ALWAYS AS ROW BEGIN	Reserved for future IBM use.The row-begin column of the SYSTEM_TIME period, for system-period data versioning.	G
SYS_END	TIMESTAMP(12) NOT NULL GENERATED ALWAYS AS ROW END	Reserved for future IBM use.The row-end column of the SYSTEM_TIME period, for system-period data versioning.	G
TRANS_START	TIMESTAMP(12) NOT NULL GENERATED ALWAYS AS TRANSACTION START ID	Reserved for future IBM use.	G

SYSPACKCOPY catalog table

The SYSPACKCOPY table contains one row for the previous version of each package and one row for the original version of each package. The schema is SYSIBM.

Table 330. SYSIBM.SYSPACKCOPY table column descriptions

Column name	Data type	Description	Use
LOCATION	VARCHAR(128) NOT NULL	Always contains blanks	S
COLLID	VARCHAR(128) NOT NULL	Name of the package collection. For a trigger package, it is the schema name of the trigger.	G
NAME	VARCHAR(128) NOT NULL	Name of the package.	G
CONTOKEN	CHAR(8) NOT NULL WITH DEFAULT FOR BIT DATA	Consistency token for the package. For a package derived from a Db2 DBRM, this is either: <ul style="list-style-type: none"> • The "level" as specified by the LEVEL option when the package's program was precompiled • The timestamp indicating when the package's program was precompiled, in an internal format. 	S
OWNER	VARCHAR(128) NOT NULL	Authorization ID of the package owner. For a trigger package, the value is the authorization ID of the owner of the trigger, which is set to the current authorization ID (the plan or package owner for static CREATE TRIGGER statement; the CURRENT SQLID for a dynamic CREATE TRIGGER statement).	G
CREATOR	VARCHAR(128) NOT NULL	Authorization ID of the creator of the package. The creator is the authorization ID under which the package was bound or rebound. For a trigger package, the value is determined differently. For dynamic SQL, it is the primary authorization ID of the user who issued the CREATE TRIGGER statement. For static SQL, it is the authorization ID of the plan or package owner.	G
TIMESTAMP	TIMESTAMP NOT NULL	Timestamp indicating when the package was created. For the previous or original copy, this is the timestamp that indicates when the package was created. For the phased-out copy, this is the timestamp indicating when the copy became phased-out.	G
BINDTIME	TIMESTAMP NOT NULL	Timestamp indicating when the package was last bound.	G
QUALIFIER	VARCHAR(128) NOT NULL	Implicit qualifier for the unqualified table, view, index, and alias names in the static SQL statements of the package.	G

⁴² Packages are divided into *sections*. The base section of the package must be in the EDM pool during the entire time the package is executing. Other sections of the package, corresponding roughly to sets of related SQL statements, are brought into the pool as needed.

Table 330. SYSIBM.SYSPACKCOPY table column descriptions (continued)

Column name	Data type	Description	Use
PKSIZE	INTEGER NOT NULL	Size of the base section ⁴² of the package, in bytes.	G
AVGSIZE	INTEGER NOT NULL	Average size, in bytes, of those sections ⁴² of the plan that contain SQL statements processed at bind time.	G
SYSENTRIES	SMALLINT NOT NULL	Number of enabled or disabled entries for this package in SYSIBM.SYSPKSYSTEM. A value of 0 if all types of connections are enabled.	G
VALID	CHAR(1) NOT NULL	Whether the package is valid: A An ALTER statement changed the description of the table or base table of a view referred to by the package. For a CREATE INDEX statement involving data sharing, VALID is also marked as "A". The changes do not invalidate the package. H An ALTER TABLE statement changed the description of the table or base table of a view referred to by the package. For releases of Db2 prior to Version 5, the change invalidates the package. N No Y Yes	G
OPERATIVE	CHAR(1) NOT NULL	Whether the package can be allocated: N No; an explicit BIND or REBIND is required before the package can be allocated. Y Yes	G
VALIDATE	CHAR(1) NOT NULL	Whether validity checking can be deferred until run time: B All checking must be performed at bind time. R Validation is done at run time for tables, views, and privileges that do not exist at bind time.	G

Table 330. SYSIBM.SYSPACKCOPY table column descriptions (continued)

Column name	Data type	Description	Use
ISOLATION	CHAR(1) NOT NULL	Isolation level when the package was last bound or rebound R RR (repeatable read) S CS (cursor stability) T RS (read stability) U UR (uncommitted read) blank Not specified, and therefore at the level specified for the plan executing the package	G
RELEASE	CHAR(1) NOT NULL	The value used for RELEASE when the package was last bound or rebound: C Value used was COMMIT. D Value used was DEALLOCATE. blank Not specified, and therefore the value specified for the plan executing the package.	G
EXPLAIN	CHAR(1) NOT NULL	EXPLAIN option specified for the package; that is, whether information on the package's statements was added to the owner of the PLAN_TABLE table: N No Y Yes	G
QUOTE	CHAR(1) NOT NULL	SQL string delimiter for SQL statements in the package: N Apostrophe Y Quotation mark	G
COMMA	CHAR(1) NOT NULL	Decimal point representation for SQL statements in package: N Period Y Comma	G

Table 330. SYSIBM.SYSPACKCOPY table column descriptions (continued)

Column name	Data type	Description	Use
HOSTLANG	CHAR(1) NOT NULL	<p>Host language, or a value set by the program preparation process:</p> <p>B Assembler language</p> <p>C OS/VS COBOL</p> <p>D C</p> <p>F Fortran</p> <p>J Java</p> <p>P PL/I</p> <p>R REST</p> <p>2 VS COBOL II or IBM COBOL Release 1 (formerly called COBOL/370)</p> <p>3 IBM COBOL (Release 2 or subsequent releases)</p> <p>4 C++</p> <p>blank For remotely bound packages, trigger packages (TYPE='T'), SQL procedure packages (TYPE='N'), or non-inline SQL scalar function packages (TYPE='F').</p>	G
CHARSET	CHAR(1) NOT NULL	<p>Indicates whether the system CCSID for SBCS data was 290 (Katakana) when the program was precompiled:</p> <p>K Yes</p> <p>A No</p>	G
MIXED	CHAR(1) NOT NULL	<p>Indicates if mixed data was in effect when the package's program was precompiled (for more on when mixed data is in effect, see "Character strings" on page 102):</p> <p>N No</p> <p>Y Yes</p>	G

Table 330. SYSIBM.SYSPACKCOPY table column descriptions (continued)

Column name	Data type	Description	Use
DEC31	CHAR(1) NOT NULL	Indicates whether DEC31 was in effect when the package's program was precompiled (for more on when DEC31 is in effect, see "Arithmetic with two decimal operands" on page 251): N No Y Yes	G
DEFERPREP	CHAR(1) NOT NULL	Indicates the CURRENTDATA option when the package was bound or rebound: A Data currency is required for all cursors. Inhibit blocking for all cursors. B Data currency is not required for ambiguous cursors. C Data currency is required for ambiguous cursors. blank The package was created before the CURRENTDATA option was available.	G
SQLERROR	CHAR(1) NOT NULL	Indicates the SQLERROR option on the most recent subcommand that bound or rebound the package: C CONTINUE N NOPACKAGE	G

Table 330. SYSIBM.SYSPACKCOPY table column descriptions (continued)

Column name	Data type	Description	Use
REMOTE	CHAR(1) NOT NULL	Source of the package: C Package was created by BIND COPY. D Package was created by BIND COPY with the OPTIONS(COMMAND) option. K The package was copied from a package that was originally bound on behalf of a remote requester. L The package was copied with the OPTIONS(COMMAND) option from a package that was originally bound on behalf of a remote requester. N Package was locally bound from a DBRM. Y Package was bound on behalf of a remote requester.	G
PCTIMESTAMP	TIMESTAMP NOT NULL	Date and time the application program was precompiled, or '0001-01-01-00.00.000000' if the LEVEL precompiler option was used, or if the package came from a non-Db2 location.	G
IBMREQD	CHAR(1) NOT NULL	A value of Y indicates that the row was provided with the Db2 product code. For all other values, see Release dependency indicators . The value in this field is not a reliable indicator of release dependencies. RELBOUND should be used instead.	G
VERSION	VARCHAR(122) NOT NULL	Version identifier for the package. The value is blank for a trigger package (TYPE='T').	G
PDSNAME	VARCHAR(132) NOT NULL	For a locally bound package, the name of the PDS (library) in which the package's DBRM is a member. For a locally copied package, the value in SYSPACKAGE.PDSNAME for the source package. Otherwise, the product signature of the bind requester followed by one of the following: <ul style="list-style-type: none"> • For Db2 for z/OS remote requesters, the requester's location name, or IP address, or LU name enclosed in angle brackets (for example, "<LUSQLDS>"). • For non-Db2 for z/OS remote requesters, the requester's IP address or LU name enclosed in angle brackets. 	G

Table 330. SYSIBM.SYSPACKCOPY table column descriptions (continued)

Column name	Data type	Description	Use
DEGREE	CHAR(3) NOT NULL WITH DEFAULT	The DEGREE option used when the package was last bound: ANY DEGREE(ANY) 1 or blank DEGREE(1). Blank if the package was migrated.	G
GROUP_MEMBER	VARCHAR(24) NOT NULL WITH DEFAULT	The Db2 data sharing member name of the Db2 subsystem that performed the most recent bind. This column is blank if the Db2 subsystem was not in a Db2 data sharing environment when the bind was performed.	G
DYNAMICRULES	CHAR(1) NOT NULL WITH DEFAULT	The DYNAMICRULES option used when the package was last bound: B BIND. Dynamic SQL statements are executed with DYNAMICRULES bind behavior. D DEFINEBIND. When the package is run under an active stored procedure or user-defined function, dynamic SQL statements in the package are executed with DYNAMICRULES define behavior. When the package is not run under an active stored procedure or user-defined function, dynamic SQL statements in the package are executed with DYNAMICRULES bind behavior. E DEFINERUN. When the package is run under an active stored procedure or user-defined function, dynamic SQL statements in the package are executed with DYNAMICRULES define behavior. When the package is not run under an active stored procedure or user-defined function, dynamic SQL statements in the package are executed with DYNAMICRULES run behavior. H INVOKEBIND. When the package is run under an active stored procedure or user-defined function, dynamic SQL statements in the package are executed with DYNAMICRULES invoke behavior. When the package is not run under an active stored procedure or user-defined function, dynamic SQL statements in the package are executed with DYNAMICRULES bind behavior.	G

Table 330. SYSIBM.SYSPACKCOPY table column descriptions (continued)

Column name	Data type	Description	Use
DYNAMICRULES (cont.)		<p>I INVOKERUN. When the package is run under an active stored procedure or user-defined function, dynamic SQL statements in the package are executed with DYNAMICRULES invoke behavior.</p> <p>When the package is not run under an active stored procedure or user-defined function, dynamic SQL statements in the package are executed with DYNAMICRULES run behavior.</p> <p>R RUN. Dynamic SQL statements are executed with DYNAMICRULES run behavior.</p> <p>blank DYNAMICRULES is not specified for the package. The package uses the DYNAMICRULES value of the plan to which the package is appended at execution time.</p> <p>For a description of the DYNAMICRULES behaviors, see “Authorization IDs and dynamic SQL” on page 94.</p>	
REOPTVAR	CHAR(1) NOT NULL WITH DEFAULT 'N'	<p>Whether the access path is determined again at execution time using input variable values:</p> <p>A Bind option REOPT(AUTO) indicates that the access path is determined multiple times at execution time depending on the parameter value.</p> <p>N Bind option REOPT(NONE) indicates that the access path is determined at bind time.</p> <p>Y Bind option REOPT(ALWAYS) indicates that the access path is determined at execution time for SQL statements with variable values.</p> <p>1 Bind option REOPT(ONCE) indicates that the access path is determined only once at execution time, using the first set of input variable values, regardless of how many times the same statement is executed.</p>	G

Table 330. SYSIBM.SYSPACKCOPY table column descriptions (continued)

Column name	Data type	Description	Use
DEFERPREPARE	CHAR(1) NOT NULL WITH DEFAULT	<p>Whether PREPARE processing is deferred until OPEN is executed:</p> <p>N Bind option NODEFER(PREPARE) indicates that PREPARE processing is not deferred until OPEN is executed.</p> <p>Y Bind option DEFER(PREPARE) indicates that PREPARE processing is deferred until OPEN is executed.</p> <p>blank Bind option not specified for the package. It is inherited from the plan.</p>	G
KEEPDYNAMIC	CHAR(1) NOT NULL WITH DEFAULT 'N'	<p>Whether prepared dynamic statements are to be purged at each commit point:</p> <p>N The bind option is KEEPDYNAMIC(NO). Prepared dynamic SQL statements are destroyed at each commit point.</p> <p>Y The bind option is KEEPDYNAMIC(YES). Prepared dynamic SQL statements are kept past each commit point.</p>	G
PATHSCHEMAS	VARCHAR(2048) NOT NULL WITH DEFAULT	SQL path specified on the BIND or REBIND command that bound the package. The path is used to resolve unqualified data type, function, and stored procedure names used in certain contexts. If the PATH bind option was not specified, the value in the column is a zero length string; however, Db2 uses the default SQL path.	G

Table 330. SYSIBM.SYSPACKCOPY table column descriptions (continued)

Column name	Data type	Description	Use
TYPE	CHAR(1) NOT NULL WITH DEFAULT	Type of package. Identifies how the package is created: F CREATE FUNCTION or ALTER FUNCTION statement, or a BIND PACKAGE DEPLOY command created the package, and this package is a non-inline SQL scalar function package. N CREATE PROCEDURE or ALTER PROCEDURE statement, or BIND PACKAGE DEPLOY command created the package, and this package is a native SQL routine package. R CREATE TRIGGER or ALTER TRIGGER statement created the package, and the package is a trigger package that has been created or regenerated in Db2 11 new-function mode or later. T CREATE TRIGGER statement prior to Db2 11 new-function mode has created the package, and the package is a trigger package. CREATE TRIGGER statement created the package, and the package is a trigger package. blank BIND PACKAGE command created the package.	G
DBPROTOCOL	CHAR(1) NOT NULL WITH DEFAULT 'P'	Whether remote access for SQL is implemented with DRDA access or DRDA access with the capability for package-based continuous block fetch: D DRDA C DRDA access with the capability for package-based continuous block fetch.	G
FUNCTIONTS	TIMESTAMP NOT NULL WITH DEFAULT	Timestamp when the function was resolved. This value is set by the BIND and REBIND commands, but not by automatic rebinds (autobind).	G
OPTHINT	VARCHAR(128) NOT NULL WITH DEFAULT	Value of the OPTHINT bind option. Identifies rows in owner.PLAN_TABLE that are to be used as input to Db2. Refer to the ACCESSPATH column in the “SYSPACKSTMT catalog table” on page 2558 for information about which statements are using the specified hints.	G

Table 330. SYSIBM.SYSPACKCOPY table column descriptions (continued)

Column name	Data type	Description	Use
ENCODING_CCSID	INTEGER NOT NULL WITH DEFAULT	The CCSID corresponding to the encoding scheme or CCSID as specified for the bind option ENCODING. The Encoding Scheme specified on the bind command: ccsid The specified or derived CCSID. 0 The default CCSID as specified on panel DSNTIPF at installation time. Used when the package was bound prior to Version 7.	G
IMMEDWRITE	CHAR(1) NOT NULL WITH DEFAULT	Indicates when writes of updated group buffer pool dependent pages are to be done. This option is only applicable for data sharing environments. N Bind option IMMEDIATEWRITE(NO) indicates normal write activity is done. Y Bind option IMMEDIATEWRITE(YES) indicates that immediate writes are done for updated group buffer pool dependent pages. 1 Bind option IMMEDIATEWRITE(PH1) indicates that updated group buffer pool dependent pages are written at or before phase 1 commit. blank A migrated package.	G
RELBOUND	CHAR(1) NOT NULL WITH DEFAULT	The release when the package was bound or rebound. blank Bound prior to Version 7 For all other values, see Release dependency indicators	G
CATENCODE	CHAR(1)	Not used.	N
REMARKS	VARCHAR(550) NOT NULL WITH DEFAULT	A character string provided by the user with the COMMENT statement.	G
OWNERTYPE	CHAR(1) NOT NULL WITH DEFAULT	Indicates the type of owner blank Authorization ID L Role	G

Table 330. SYSIBM.SYSPACKCOPY table column descriptions (continued)

Column name	Data type	Description	Use
ROUNDING	CHAR(1) NOT NULL WITH DEFAULT	<p>The ROUNDING option used when the package was last bound:</p> <p>C ROUND_CEILING</p> <p>D ROUND_DOWN</p> <p>F ROUND_FLOOR</p> <p>G ROUND_HALF_DOWN</p> <p>E ROUND_HALF_EVEN</p> <p>H ROUND_HALF_UP</p> <p>U ROUND_UP</p> <p>blank The package created in a Db2 release prior to Version 9.</p>	G
DISTRIBUTE	CHAR(1) NOT NULL WITH DEFAULT 'N'	<p>Determines if Db2 should gather location names from SQL statements, and create remote packages for the user (This only has effect during local bind):</p> <p>A Db2 will collect remote location names from SQL statements during local bind, and automatically create remote packages at those sites. The site names are gathered from object names in static SQL statements and literals on CONNECT statements. The sites at which the package is remotely bound can be determined by the location (BTYPE='X') records in SYSIBM.SYSPACKDEP for this package.</p> <p>L Db2 will automatically create remote packages at the sites specified in the list of location-names. The sites at which the package is remotely bound can be determined by the location (BTYPE='X') records in SYSIBM.SYSPACKDEP for this package.</p>	G
LASTUSED	DATE NOT NULL WITH DEFAULT	The last date that the corresponding objects are used.	G

Table 330. SYSIBM.SYSPACKCOPY table column descriptions (continued)

Column name	Data type	Description	Use
CONCUR_ACC_RES	CHAR(1) NOT NULL	Indicates the CONCURRENTACCESSRESOLUTION option when the package was bound or rebound: blank Not specified U USECURRENTLYCOMMITTED W WAITFOROUTCOME	G
EXTENDEDINDICATOR	CHAR(1) NOT NULL WITH DEFAULT	The value of the EXTENDEDINDICATOR bind option: N EXTENDEDINDICATOR NO Y EXTENDEDINDICATOR YES	G
COPYID	INTEGER NOT NULL	The version of the copy of the package that this row explains: 0 or 4 through 16 The phased-out copy of the package 1 The previous copy of the package 2 The original copy of the package	G
PLANMGMT	CHAR(1) NOT NULL WITH DEFAULT	The value of the PLANMGMT bind option: E PLANMGMT EXTENDED B PLANMGMT BASIC blank PLANMGMT OFF	G
PLANMGMTSCOPE	CHAR(1) NOT NULL WITH DEFAULT	The value of the PLANMGMTSCOPE bind option: S PLANMGMTSCOPE STATIC	G
APREUSE	CHAR(1) NOT NULL WITH DEFAULT	The value of the APREUSE bind option: N NO or NONE: Access paths are not reused. E ERROR: Db2 tries to reuse access paths. Processing ends when an access path cannot be reused.	I

Table 330. SYSIBM.SYSPACKCOPY table column descriptions (continued)

Column name	Data type	Description	Use
APRETAINDUP	CHAR(1) NOT NULL WITH DEFAULT	The value of the APRETAINDUP bind option: Y APRETAINDUP YES specified. All copies were retained. 0 APRETAINDUP NO specified; however, the previous or original package copy is still retained due to access path differences. 1 APRETAINDUP NO specified, and the previous package copy is not retained as the access paths are identical to the current copy. 2 APRETAINDUP NO specified, and the previous and original package copies are not retained as the access paths are identical to the current copy.	G
SYSTIMESENSITIVE	CHAR(1) NOT NULL WITH DEFAULT 'N'	The value of the SYSTIMESENSITIVE bind option: Y References to system-period temporal tables are affected by the value of the CURRENT TEMPORAL SYSTEM_TIME special register. N References to system-period temporal tables are not affected by the value of the CURRENT TEMPORAL SYSTEM_TIME special register.	G
RECORDTEMPORALHIST	CHAR(1) NOT NULL WITH DEFAULT 'Y'	Not used.	N
BUSTIMESENSITIVE	CHAR(1) NOT NULL WITH DEFAULT 'N'	The value of the BUSTIMESENSITIVE bind option: Y References to application-period temporal tables are affected by the value of the CURRENT TEMPORAL BUSINESS_TIME special register. N References to application-period temporal tables are not affected by the value of the CURRENT TEMPORAL BUSINESS_TIME special register.	G

Table 330. SYSIBM.SYSPACKCOPY table column descriptions (continued)

Column name	Data type	Description	Use
APPLCOMPAT	VARCHAR(10) NOT NULL WITH DEFAULT 'Y'	The value of the APPLCOMPAT bind option: V10R1 SQL statements in the package have V10R1 compatibility behavior. V11R1 SQL statements in the package have V11R1 compatibility behavior.	G
ARCHIVESENSITIVE	CHAR(1) NOT NULL WITH DEFAULT 'N'	The value of the ARCHIVESENSITIVE bind option. Y References to archive-enabled tables are affected by the value of the SYSIBMADM.GET_ARCHIVE built-in global variable. Y is the default value. N References to archive-enabled tables are not affected by the value of the SYSIBMADM.GET_ARCHIVE built-in global variable.	G
EXTSEQNO	INTEGER NOT NULL WITH DEFAULT 0	Internal use only.	I
DESCSTAT	CHAR(1) NOT NULL WITH DEFAULT	The value of the DESCSTAT bind option. Y The Db2 database manager generates a DESCRIBE SQLDA at bind time so that DESCRIBE requests for static SQL can be satisfied during execution. N The Db2 database manager does not generate a DESCRIBE SQLDA at bind time for static SQL statements.	G

Table 330. SYSIBM.SYSPACKCOPY table column descriptions (continued)

Column name	Data type	Description	Use
ORIGIN	CHAR(1) NOT NULL WITH DEFAULT	The origin of the EXPLAIN records: A Automatic bind B BIND command G Explicit ALTER REGENERATE of the SQL procedure for the package I Implicit automatic regeneration of the SQL procedure for the package R REBIND command blank The row existed before Db2 12. This is the default value.	G
APREUSE_NO_FL	VARCHAR(10) NOT NULL WITH DEFAULT	The function level when the package was bound with APREUSE(NO), or blank if the package was bound before Db2 12, or not determined. This is the default value.	G
APREUSE_NO_TS	TIMESTAMP NOT NULL WITH DEFAULT	The bind time when the package was bound with APREUSE(NO): 0001-01-01-00.00.00.000000 The package was bound before Db2 12. This is the default value.	G
CONC_STMT	CHAR(1) NOT NULL WITH DEFAULT 'N'	Whether statement concentration is enabled: N No. This is the default value. Y Yes	G
FUNCTION_LVL	VARCHAR(10)	The function level of the package.	G

SYSPACKDEP catalog table

The SYSPACKDEP table records the dependencies of packages on local tables, views, synonyms, table spaces, indexes, aliases, functions, and stored procedures. The schema is SYSIBM.

Access paths for SQL statements might depend on objects that Db2 does not actually use when it processes the selected access paths. Such dependencies are recorded in the SYSPACKDEP catalog table, but they are not shown in EXPLAIN output.

Table 331. SYSIBM.SYSPACKDEP table column descriptions

Column name	Data type	Description	Use
BNAME	VARCHAR(128) NOT NULL	The name of an object that a package depends on. If BTYPE is W or Z, the value is the name of the table on which the period is defined.	G

Table 331. SYSIBM.SYSPACKDEP table column descriptions (continued)

Column name	Data type	Description	Use
BQUALIFIER	VARCHAR(128) NOT NULL	The value of the column depends on the type of object: <ul style="list-style-type: none">• If BNAME identifies a table space (BTYPE is R), the value is the name of its database.• If BNAME identifies a table on which a period is defined (BTYPE is W or Z), the value is the qualifier of that table.• If BNAME identifies user-defined function, a cast function, a stored procedure, or a sequence (BTYPE is F, O, or Q), the value is the schema name.• If BNAME identifies a role, the value is blank.• Otherwise, the value is the schema of BNAME.	G

Table 331. SYSIBM.SYSPACKDEP table column descriptions (continued)

Column name	Data type	Description	Use
BTYPE	CHAR(1) NOT NULL	Type of object identified by BNAME and BQUALIFIER: A Alias E INSTEAD OF trigger F User-defined function or cast function H Global variable G Global temporary table I Index M Materialized query table O Stored procedure P Partitioned table space if it is defined as LARGE or with the DSSIZE parm Q Sequence object R Table space S Synonym T Table U User-defined type, which is a distinct type or an array type. V View W SYSTEM_TIME period Z BUSINESS_TIME period 0 (zero) Sequence alias	G
DLOCATION	VARCHAR(128) NOT NULL	Always contains blanks	S
DCOLLID	VARCHAR(128) NOT NULL	Name of the package collection.	G

Table 331. SYSIBM.SYSPACKDEP table column descriptions (continued)

Column name	Data type	Description	Use
DNAME	VARCHAR(128) NOT NULL	Name of the package.	G
DCONTOKEN	CHAR(8) NOT NULL FOR BIT DATA	Consistency token for the package. This is either: <ul style="list-style-type: none"> The "level" as specified by the LEVEL option when the package's program was precompiled The timestamp indicating when the package's program was precompiled, in an internal format. 	S
IBMREQD	CHAR(1) NOT NULL	A value of Y indicates that the row was provided with the Db2 product code. For all other values, see Release dependency indicators . The value in this field is not a reliable indicator of release dependencies.	G
DOWNER	VARCHAR(128) NOT NULL WITH DEFAULT	Owner of the package:	G
DTYPE	CHAR(1) NOT NULL WITH DEFAULT	Type of package: <p>F Compiled SQL scalar function</p> <p>N Native SQL routine package</p> <p>O Original copy of a package</p> <p>P Previous copy of a package</p> <p>R Reserved for IBM use</p> <p>T Trigger package for a basic trigger</p> <p>blank Not a trigger package or a native SQL routine package</p> <p>1 Trigger package for an advanced trigger</p>	G
DOWNERTYPE	CHAR(1) NOT NULL WITH DEFAULT	Indicates the type of owner of the package: <p>blank Authorization ID</p> <p>L Role</p>	G
COPYID	INTEGER NULLABLE	The copy ID of the package.	G

Related reference

[SYSDYNQRYDEP catalog table](#)

The SYSDYNQRYDEP table contains information about dependencies for dynamic query packages. The schema is SYSIBM.

SYSPACKLIST catalog table

The SYSPACKLIST table contains one or more rows for every local application plan bound with a package list. Each row represents a unique entry in the plan's package list. The schema is SYSIBM.

Table 332. SYSIBM.SYSPACKLIST table column descriptions

Column name	Data type	Description	Use
PLANNAME	VARCHAR(24) NOT NULL	Name of the application plan.	G
SEQNO	SMALLINT NOT NULL	Sequence number of the entry in the package list.	G
LOCATION	VARCHAR(128) NOT NULL	Location of the package. Blank if this is local. An asterisk (*) indicates location to be determined at run time.	G
COLLID	VARCHAR(128) NOT NULL	Collection name for the package. An asterisk (*) indicates that the collection name is determined at run time.	G
NAME	VARCHAR(128) NOT NULL	Name of the package. An asterisk (*) indicates an entire collection.	G
TIMESTAMP	TIMESTAMP NOT NULL	Timestamp indicating when the row was created.	G
IBMREQD	CHAR(1) NOT NULL	A value of Y indicates that the row was provided with the Db2 product code. For all other values, see Release dependency indicators . The value in this field is not a reliable indicator of release dependencies.	G

SYSPACKSTMT catalog table

The SYSPACKSTMT table contains one or more rows for each SQL statement in a package that is bound locally, and one or more rows for a subset of the SQL statements in a package that is bound remotely. The schema is SYSIBM.

Table 333. table column descriptions

Column name	Data type	Description	Use
LOCATION	VARCHAR(128) NOT NULL	Always contains blanks	S
COLLID	VARCHAR(128) NOT NULL	Name of the package collection.	G

Table 333. table column descriptions (continued)

Column name	Data type	Description	Use
NAME	VARCHAR(128) NOT NULL	Name of the package.	G
CONTOKEN	CHAR(8) NOT NULL FOR BIT DATA	Consistency token for the package. This is either: <ul style="list-style-type: none"> The "level" as specified by the LEVEL option when the package's program was precompiled The timestamp indicating when the package's program was precompiled, in an internal format 	S
SEQNO	INTEGER NOT NULL	Sequence number of the statement. Rows that contain zero in the SEQNO, STMTNO, and SECTNO column values are for IBM internal use only.	G
STMTNO	SMALLINT NOT NULL	The statement number of the statement in the source program. If the STMTNO value is zero, the statement number is greater 32767 and the STMTNOI column contains the statement number. A negative value indicates a statement number greater than 32767 in a DRBM created in DB2 version 2.2 or earlier. To convert a negative value to a meaningful statement number, add 65536 to the negative STMTNO value. For example, -26472 is equivalent to +39064 (-26472 + 65536). Rows that contain zero in the SEQNO, STMTNO, and SECTNO column values are for IBM internal use only.	G
SECTNO	SMALLINT NOT NULL	The section number of the statement. For generated packages for SQL routines, such as procedures and user-defined functions, and advanced triggers, a value of 1 indicates the control statement for the routine or advanced trigger. For basic trigger packages, a value of 1 indicates the WHEN clause for activating the trigger. Rows that contain zero in the SEQNO, STMTNO, and SECTNO column values are for IBM internal use only.	G
BINDERROR	CHAR(1) NOT NULL	Whether an SQL error was detected at bind time: N No Y Yes	G
IBMREQD	CHAR(1) NOT NULL	A value of Y indicates that the row was provided with the Db2 product code. For all other values, see Release dependency indicators . The value in this field is not a reliable indicator of release dependencies.	G

Table 333. table column descriptions (continued)

Column name	Data type	Description	Use
VERSION	VARCHAR(122) NOT NULL	Version identifier for the package.	G
–	VARCHAR(3500) NOT NULL WITH DEFAULT FOR BIT DATA	Internal use only.	I
ISOLATION	CHAR(1) NOT NULL WITH DEFAULT	Isolation level for the SQL statement: R RR (repeatable read) T RS (read stability) S CS (cursor stability) U UR (uncommitted read) L RS isolation, with a <i>lock-clause</i> X RR isolation, with a <i>lock-clause</i> blank The WITH clause was not specified on this statement. The isolation level is recorded in SYSPACKAGE.ISOLATION and in SYSPLAN.ISOLATION.	G

Table 333. table column descriptions (continued)

Column name	Data type	Description	Use
STATUS	CHAR(1) NOT NULL WITH DEFAULT	<p>Status of binding the statement:</p> <p>A Distributed - statement uses Db2 private protocol access. The statement will be parsed and executed at the server using defaults for input variables during access path selection.</p> <p>B Distributed - statement uses Db2 private protocol access. The statement will be parsed and executed at the server using values for input variables during access path selection.</p> <p>C Compiled - statement was bound successfully using defaults for input variables during access path selection.</p> <p>D Distributed - statement references a remote object using a three-part name. Db2 will implicitly use DRDA access either because the DBPROTOCOL bind option was not specified (defaults to DRDA), or the bind option DBPROTOCOL(DRDA) was explicitly specified. This option allows the use of three-part names with DRDA access but it requires that the package be bound at the target remote site.</p> <p>E Explain - statement is an SQL EXPLAIN statement. The explain is done at bind time using defaults for input variables during access path selection.</p> <p>F Parsed - statement did not bind successfully and VALIDATE(RUN) was used. The statement will be rebound at execution time using values for input variables during access path selection.</p> <p>G Compiled - statement bound successfully, but REOPT is specified. The statement will be rebound at execution time using values for input variables during access path selection.</p> <p>H Parsed - statement is either a data definition statement or a statement that did not bind successfully and VALIDATE(RUN) was used. The statement will be rebound at execution time using defaults for input variables during access path selection. Data manipulation statements use defaults for input variables during access path selection.</p> <p>I Indefinite - statement is dynamic. The statement will be bound at execution time using defaults for input variables during access path selection.</p>	S

Table 333. table column descriptions (continued)

Column name	Data type	Description	Use
STATUS (cont.)		<p>J Indefinite - statement is dynamic. The statement will be bound at execution time using values for input variables during access path selection.</p> <p>K Control - CALL statement.</p> <p>L Bad - the statement has some allowable error. The bind continues but the statement cannot be executed.</p> <p>M Parsed - statement references a table that is qualified with SESSION and was not bound because the table reference could be for a declared temporary table that will not be defined until the package or plan is run. The SQL statement will be rebound at execution time using values for input variables during access path selection.</p> <p>O Compiled for acceleration. The static query was bound successfully for acceleration and will be routed to an accelerator when executed.</p> <p>blank The statement is non-executable, or was bound in a Db2 release prior to Version 5.</p>	
ACCESSPATH	CHAR(1) NOT NULL WITH DEFAULT	<p>For static statements, indicates if the access path for the statement is based on user-specified optimization hints:</p> <p>H Optimization hints were used.</p> <p>A The access path was reused because of the APREUSE bind option.</p> <p>blank One of the following situations:</p> <ul style="list-style-type: none"> • The access path was determined without the use of hints, and a previous access path was not reused. • No access path is associated with the statement. • The statement is a dynamic SQL statement 	G
STMTNOI	INTEGER NOT NULL WITH DEFAULT	<p>The statement number of the statement in the source program.</p> <p>A negative value indicates a statement number greater than 32767 in a DRBM created in DB2 version 2.2 or earlier. To convert a negative value to a meaningful statement number, add 65536 to the negative STMTNOI value. For example, -26472 is equivalent to +39064 (-26472 + 65536).</p>	G

Table 333. table column descriptions (continued)

Column name	Data type	Description	Use
SECTNOI	INTEGER NOT NULL WITH DEFAULT	The section number of the statement. For generated packages for SQL routines, such as procedures and user-defined functions, and advanced triggers, a value of 1 indicates the control statement for the routine or advanced trigger. For basic trigger packages, a value of 1 indicates the WHEN clause for activating the trigger.	G
EXPLAINABLE	CHAR(1) NOT NULL WITH DEFAULT	Contains one of the following values: Y Indicates that the SQL statement can be used with the EXPLAIN function and might have rows describing its access path in the owner.PLAN_TABLE. N Indicates that the SQL statement does not have any rows describing its access path in the owner.PLAN_TABLE. blank Indicates that the SQL statement was bound prior to Version 7.	G
QUERYNO	INTEGER NOT NULL WITH DEFAULT -1	The query number of the SQL statement in the source program. SQL statements bound prior to Version 7 have a default value of -1. Statements bound in Version 7 or later use the value specified on the QUERYNO clause on SELECT, UPDATE, INSERT, DELETE, EXPLAIN, DECLARE CURSOR, or REFRESH TABLE statements. If the QUERYNO clause is not specified, the query number is set to the statement number.	G
ROWID	ROWID NULL GENERATED ALWAYS	ROWID column, created for the lob columns in this table.	G
STMT_ID	BIGINT NOT NULL	A unique statement identifier.	G
STATEMENT	CLOB(2M) NOT NULL WITH DEFAULT	The complete text for the SQL statement that the row represents.	G
-	BLOB(2M) NOT NULL WITH DEFAULT	Internal use only.	I

Table 333. table column descriptions (continued)

Column name	Data type	Description	Use
EXPANSION_REASON	CHAR(2) NOT NULL	<p>For dynamic statements, this column is blank. For static statements, one of the following values to indicate the reason that an implicit query transformation occurred when the package was bound:</p> <p>A The statement was bound with implicit query transformation as a result of the SYSIBMADM.GET_ARCHIVE built-in global variable.</p> <p>B The statement was bound with implicit query transformation as a result of the CURRENT TEMPORAL BUSINESS_TIME special register.</p> <p>S The statement was bound with implicit query transformation as a result of the CURRENT TEMPORAL SYSTEM_TIME special register.</p> <p>SB The statement was bound with implicit query transformation as a result of the CURRENT TEMPORAL SYSTEM_TIME special register and the CURRENT TEMPORAL BUSINESS_TIME special register.</p> <p>blank One of the following occurred:</p> <ul style="list-style-type: none"> The statement did not bind successfully and the VALIDATE(RUN) bind option was used. The statement was bound without implicit query transformation. 	G
QUERYID	BIGINT NOT NULL WITH DEFAULT -1	The unique identifier for locating records in the SYSIBM.SYSQUERY catalog table. The default value is -1 indicates that no QUERYID value was found for the SQL statement when the package was bound.	G
QUERY_HASH	CHAR(16) NOT NULL WITH DEFAULT FOR BIT DATA	<p>The hash key for locating records in the SYSIBM.SYSQUERY catalog table. This value is not unique for each statement. Other columns for the collection ID, package name, section number, and query number can be used with the hash key for uniqueness.</p> <p>The '00'x default value indicates that no hash key was generated for the SQL statement when the package was bound.</p>	G
QUERY_HASH_VERSION	INTEGER NOT NULL WITH DEFAULT -1	The hash version for locating records in the SYSIBM.SYSQUERY catalog table. The -1 default value indicates that no hash version was generated for the SQL statement when the package was bound.	G
COPYID	INTEGER NULLABLE	The copy ID of the package.	G

SYSPACKSTMT_STMB catalog table

The SYSPACKSTMT_STMB table is an auxiliary table for the STMTBLOB column of the SYSPACKSTMT table and is required to hold LOB data. The schema is SYSIBM.

Table 334. SYSIBM.SYSPACKSTMT_STMB table column descriptions

Column name	Data type	Description	Use
—	BLOB(2M) NOT NULL WITH DEFAULT	Internal use only.	I

SYSPACKSTMT_STMT catalog table

The SYSPACKSTMT_STMT table is an auxiliary table for the STATEMENT column of the SYSPACKSTMT table and contains the LOB data. The schema is SYSIBM.

Table 335. SYSIBM.SYSPACKSTMT_STMT table column descriptions

Column name	Data type	Description	Use
STATEMENT	CLOB(2M) NOT NULL WITH DEFAULT	The complete text for the SQL statement that the row represents.	G

SYSPARMS catalog table

The SYSPARMS table contains a row for each parameter of a routine or multiple rows for table parameters (one for each column of the table). The schema is SYSIBM.

Table 336. SYSIBM.SYSPARMS table column descriptions

Column name	Data type	Description	Use
SCHEMA	VARCHAR(128) NOT NULL	Schema of the routine.	G
OWNER	VARCHAR(128) NOT NULL	Owner of the routine.	G
NAME	VARCHAR(128) NOT NULL	Name of the routine.	G
SPECIFICNAME	VARCHAR(128) NOT NULL	Specific name of the routine.	G
ROUTINETYPE	CHAR(1) NOT NULL	Type of routine: F User-defined function or cast function P Stored procedure	G

Table 336. SYSIBM.SYSPARMS table column descriptions (continued)

Column name	Data type	Description	Use
CAST_FUNCTION	CHAR(1) NOT NULL	Whether the routine is a cast function: N Not a cast function Y A cast function The only way to get a value of Y is if a user creates a distinct type when Db2 implicitly generates cast functions for the distinct type.	G
PARAMNAME	VARCHAR(128) NOT NULL	Name of the parameter. For a table parameter, the parameter name in the row corresponding to the first column of the table is the parameter name specified on CREATE; an empty string or blanks are stored for the parameter name for the rows corresponding to the remaining columns.	G
ROUTINEID	INTEGER NOT NULL	Internal identifier of the routine.	S

Table 336. SYSIBM.SYSPARMS table column descriptions (continued)

Column name	Data type	Description	Use
ROWTYPE	CHAR(1) NOT NULL	<p>The following values indicate the type of parameter described by this row:</p> <p>P Input parameter.</p> <p>O Output parameter; not applicable for functions</p> <p>B Both an input and an output parameter; not applicable for functions</p> <p>R Result before casting; not applicable for stored procedures</p> <p>C Result after casting; not applicable for stored procedures</p> <p>S Input parameter of the underlying built-in source function. For a sourced function and a given ORDINAL value:</p> <ul style="list-style-type: none"> • The row with ROWTYPE = P describes the input parameter of the user-defined function (identified by ROUTINEID). • The row with ROWTYPE = S describes the corresponding input parameter of the built-in function that is the underlying source function (identified by the SOURCESHEMA and SOURCESPECIFIC values). <p>A value of 'X' indicates that the row is not used to describe a particular parameter of the routine. Instead, for a routine that was created prior to Version 9, the row is used to record a CCSID for the encoding scheme specified in a PARAMETER CCSID clause, or a DATATYPEID for the representation of the variable length character string parameters of a LANGUAGE C routine, as specified in a PARAMETER VARCHAR clause. For routines created with Version 8 (new function mode) or later releases, the CCSID is recorded in the PARAMETER_CCSID column of SYSROUTINES. For routines created with Version 9 or later releases, the DATATYPEID information to support PARAMETER VARCHAR is recorded in the PARAMETER_VARCHARFORM column of SYSIBM.SYSROUTINES.</p>	G

Table 336. SYSIBM.SYSPARMS table column descriptions (continued)

Column name	Data type	Description	Use
ORDINAL	SMALLINT NOT NULL	<p>If ROWTYPE is B, O, P, or S, the value is the ordinal number of the parameter within the routine signature.</p> <p>If ROWTYPE is C or R, the value depends on the type of function:</p> <ul style="list-style-type: none"> • For a scalar function, the value is 0. • For a table function, the value is the ordinal number of the column of the output table. <p>If ROWTYPE is X, the value is 0.</p>	G
TYPESHEMA	VARCHAR(128) NOT NULL	Schema of the data type of the parameter.	G
TYPENAME	VARCHAR(128) NOT NULL	Name of the data type of the parameter.	G
DATATYPEID	INTEGER NOT NULL	<p>For a built-in data type, the internal ID of the built-in type. For a distinct type, the internal ID of the distinct type.</p> <p>When ROWTYPE is X and ORDINAL is 0, a non-zero DATATYPEID indicates that actual representation, for a LANGUAGE C routine, of any varying length string parameters that appear in the routine's parameter list ot in the RETURNS clause.</p>	S
SOURCETYPEID	INTEGER NOT NULL	For a built-in data type, 0. For a distinct type, the internal ID of the built-in data type upon which the distinct type is based.	S
LOCATOR	CHAR(1) NOT NULL	<p>Indicates whether a locator to a value, instead of the actual value, is to be passed or returned when the routine is called:</p> <p>N The actual value is to be passed.</p> <p>Y A locator to a value is to be passed</p>	G
TABLE	CHAR(1) NOT NULL	<p>The data type of a column for a table parameter:</p> <p>N This is not a table parameter.</p> <p>Y This is a table parameter.</p>	G
TABLE_COLNO	SMALLINT NOT NULL	For table parameters, the column number of the table. Otherwise, the value is 0.	G

Table 336. SYSIBM.SYSPARMS table column descriptions (continued)

Column name	Data type	Description	Use
LENGTH	INTEGER NOT NULL	Length attribute of the parameter or result; If the parameter or result length is determined during function resolution, the length attribute can also be 0. In the case of a decimal parameter or result this is the precision. If the parameter is an array, the value is 0.	G
SCALE	SMALLINT NOT NULL	Scale of the data type of the parameter or number of fractional second digits of timestamp or timestamp with time zone parameter. If it is TIMESTAMP parameter where LENGTH is 10 and SCALE is 0, the number of fractional second digits is 6.	G
SUBTYPE	CHAR(1) NOT NULL	If the data type is a distinct type, the subtype of the distinct type, which is based on the subtype of its source type: B The subtype is FOR BIT DATA. S The subtype is FOR SBCS DATA. M The subtype is FOR MIXED DATA. blank The source type is not a character type. If the parameter is an array type, the value is blank.	G
CCSID	INTEGER NOT NULL	CCSID of the data type for a character, date, time, timestamp or graphic data type. If the parameter is a datetime array, the value is 0. (not null) When ROWTYPE is X and ORDINAL is 0, the CCSID column is the CCSID for all character and graphic string parameters.	G
CAST_FUNCTION_ID	INTEGER NOT NULL	Internal function ID of the function used to cast the argument, if this function is sourced on another function, or result. Otherwise, the value is 0. Not applicable for stored procedures.	S
ENCODING_SCHEME	CHAR(1) NOT NULL	Encoding scheme of the parameter: A ASCII E EBCDIC U Unicode blank The source type is not a character, graphic, or datetime type. If the parameter is an array type, the value is blank.	G

Table 336. SYSIBM.SYSPARMS table column descriptions (continued)

Column name	Data type	Description	Use
IBMREQD	CHAR(1) NOT NULL	A value of Y indicates that the row was provided with the Db2 product code. For all other values, see Release dependency indicators . The value in this field is not a reliable indicator of release dependencies.	G
VERSION	VARCHAR(122) NOT NULL WITH DEFAULT	The version identifier for the routine. The column is a zero-length string if the value of ORIGIN is not 'I' or if the rows were created prior to Version 9.	G
OWNERTYPE	CHAR(1) NOT NULL WITH DEFAULT	Indicates the type of owner: blank Authorization ID L Role	G

SYSPENDINGDDL catalog table

The SYSPENDINGDDL table contains information about which objects have pending definition changes. The entries only exist during the window between when the pending option is executed and when the utility applies these pending changes to the object. The schema is SYSIBM.

Table 337. SYSIBM.SYSPENDINGDDL table column descriptions

Column name	Data type	Description	Use
DBNAME	VARCHAR(24) NOT NULL	Name of the database for the pending option.	G
TSNAME	VARCHAR(24) NOT NULL	Name of the table space for the pending option.	G
DBID	SMALLINT NOT NULL	Internal identifier of the database.	S
PSID	SMALLINT NOT NULL	Internal identifier of the table space page set descriptor.	S
OBJSHEMA	VARCHAR(128) NOT NULL	The qualifier of the object that contains the pending option.	G
OBJNAME	VARCHAR(128) NOT NULL	Name of the object that contains the pending option.	G
OBJJOBID	SMALLINT NOT NULL	Internal identifier of the object.	S

Table 337. SYSIBM.SYSPENDINGDDL table column descriptions (continued)

Column name	Data type	Description	Use
OBJTYPE	CHAR(1) NOT NULL	Type of object that is identified by OBJSCHEMA and OBJNAME. I The object is an index S The object is a table space T The object is a table	G
STATEMENT_TYPE	CHAR(1) NOT NULL	The type of the statement for the pending option. A An ALTER statement R A RECOVER statement	G
OPTION_ENVID	INTEGER NOT NULL	Internal identifier of the environment for the pending option.	G
OPTION_KEYWORD	VARCHAR(128) NOT NULL	If the row is inserted into this table during execution of a data definition statement, this value is the name of the pending option. If the row is inserted into this table during recovery to a prior point in time, this value is the name of the RECOVER option.	G
OPTION_VALUE	VARCHAR(4000) NOT NULL	If the row is inserted into this table during execution of a data definition statement, this value is the value of the pending option. If the row is inserted into this table during recovery to a prior point in time, this value is the value of the RECOVER option.	G
OPTION_SEQNO	SMALLINT NOT NULL	The sequence of the pending option within the statement.	G
CREATEDTS	TIMESTAMP(12) NOT NULL	Timestamp when the pending option was created.	G
RELCREATED	CHAR(1) NOT NULL	The release of Db2 that is used to create the object. See Release dependency indicators for the values.	G
IBMREQD	CHAR(1) NOT NULL	A value of Y indicates that the row was provided with the Db2 product code. For all other values, see Release dependency indicators . The value in this field is not a reliable indicator of release dependencies. RELCREATED should be used instead.	G
ROWID	ROWID	ID to support LOB columns for source text	G
STATEMENT_TEXT	CLOB(2M) NOT NULL	The source text of the original statement for the pending option.	G

Table 337. SYSIBM.SYSPENDINGDDL table column descriptions (continued)

Column name	Data type	Description	Use
COLNAME	VARCHAR(128) NOT NULL WITH DEFAULT	The name of the column with a pending definition change.	G
PARTITION	SMALLINT NOT NULL	The physical partition number that was specified in the alter statement. The value is 0 if no physical partition number was specified.	G
PARTITION_ KEYWORD	VARCHAR(18) NOT NULL WITH DEFAULT	This column is populated if the PARTITION column has a non-zero value. The keyword that is associated with the PARTITION clause of the ALTER TABLE statement. For example, suppose that you issued the following statement: <pre>ALTER TABLE ALTER PARTITION</pre> In that case, this column contains ALTER.	G
COLUMN_ KEYWORD	VARCHAR(18) NOT NULL WITH DEFAULT	This column contains the keyword that corresponds to the column that is listed in COLNAME.	G
REORG_SCOPE_ LOWPART	SMALLINT	Logical partition number of the lowest partition in the range for REORG to materialize pending definition changes. Adjacent logical partitions must be reorganized together to materialize pending definition changes. The value is 0 if the range is the entire partitioned table space or index space, or if the record is generated by the RECOVER utility. This column contains the null value when the value is unknown for pending definition changes executed prior to Db2 12.	
REORG_SCOPE_ HIGHPART	SMALLINT	Logical partition number of the highest partition in the range for REORG to materialize pending definition changes. Adjacent logical partitions must be reorganized together to materialize pending definition changes. The value is 0 if the range is the entire partitioned table space or index space, or if the record is generated by the RECOVER utility. This column contains the null value when the value is unknown for pending definition changes executed prior to Db2 12.	

SYSPENDINGOBJECTS catalog table

The SYSPENDINGOBJECTS table contains the name of and OBID information about objects that are the pending creation. The data sets for these objects are created but the object definition have not been materialized to the catalog. The entries in this table only exist during the time between when the names

of the new objects are generated and when the catalog definition of the new objects are materialized. The schema is SYSIBM.

Table 338. SYSIBM.SYSPENDINGOBJECTS table column descriptions

Column name	Data type	Description	Use
DBNAME	VARCHAR(24) NOT NULL	Name of the database.	G
TSNAME	VARCHAR(24) NOT NULL	Name of the base table space.	G
DBID	SMALLINT NOT NULL	Internal identifier of the database.	S
PSID	SMALLINT NOT NULL	Internal identifier of the base table space page set descriptor.	S
PARTITION	SMALLINT NOT NULL	Partition number with which the object is associated.	G
COLNAME	VARCHAR(128) NOT NULL	Name of the column contained in the base table space with which the object is associated.	G
OBJSCHEMA	VARCHAR(128) NOT NULL	The qualifier of the object.	G
OBJNAME	VARCHAR(128) NOT NULL	Name of the object.	G
OBJTYPE	CHAR(1) NOT NULL	Type of object identified by OBJSCHEMA and OBJNAME. I The object is an index S The object is a table space T The object is a table	G
INDEXSPACE	VARCHAR(24) NOT NULL	Name of the index space. An empty string if the object is not an index.	G
OBJJOBID	SMALLINT NOT NULL	Internal identifier of the object.	S
OBJPSID	SMALLINT NOT NULL	Internal identifier of the object page set descriptor, or 0 if the object does not have a page set descriptor.	S

SYSPKSYSTEM catalog table

The SYSPKSYSTEM table contains zero or more rows for each package. Each row for a given package represents one or more connections to an environment where the package can be executed. The schema is SYSIBM.

Table 339. SYSIBM.SYSPKSYSTEM table column descriptions

Column name	Data type	Description	Use
LOCATION	VARCHAR(128) NOT NULL	Always contains blanks	S
COLLID	VARCHAR(128) NOT NULL	Name of the package collection.	G
NAME	VARCHAR(128) NOT NULL	Name of the package.	G
CONTOKEN	CHAR(8) NOT NULL FOR BIT DATA	Consistency token for the package. This is either: <ul style="list-style-type: none"> The "level" as specified by the LEVEL option when the package's program was precompiled The timestamp indicating when the package's program was precompiled, in an internal format. 	S
SYSTEM	VARCHAR(24) NOT NULL	Environment. Values can be: <p>BATCH TSO batch</p> <p>CICS Customer Information Control System</p> <p>DB2CALL Db2 call attachment facility</p> <p>DLIBATCH DLI batch support facility</p> <p>IMSBMP IMS BMP region</p> <p>IMSMPP IMS MPP and IFP region</p> <p>REMOTE remote server</p>	G
ENABLE	CHAR(1) NOT NULL	Indicates whether the connections represented by the row are enabled or disabled: <p>N Disabled</p> <p>Y Enabled</p>	G

Table 339. SYSIBM.SYSPKSYSTEM table column descriptions (continued)

Column name	Data type	Description	Use
CNAME	VARCHAR(60) NOT NULL	Identifies the connection or connections to which the row applies. Interpretation depends on the environment specified by SYSTEM. Values can be: <ul style="list-style-type: none"> • Blank if SYSTEM=BATCH or SYSTEM=DB2CALL • The LU name for a database server if SYSTEM=REMOTE • Either the requester's location (if the product is Db2) or the requester's LU name enclosed in angle brackets if SYSTEM=REMOTE. • The name of a single connection if SYSTEM has any other value. <p>CNAME can also be blank when SYSTEM is not equal to BATCH or DB2CALL. When this is so, the row applies to all servers or connections for the indicated environment.</p>	G
IBMREQD	CHAR(1) NOT NULL	A value of Y indicates that the row was provided with the Db2 product code. For all other values, see Release dependency indicators . The value in this field is not a reliable indicator of release dependencies.	G

SYSPLAN catalog table

The SYSPLAN table contains one row for each application plan. The schema is SYSIBM.

Column name	Data type	Description	Use
NAME	VARCHAR(24) NOT NULL	Name of the application plan.	G
CREATOR	VARCHAR(128) NOT NULL	Authorization ID of the owner of the application plan.	G
BINDDATE	CHAR(6) NOT NULL	Not used.	N
VALIDATE	CHAR(1) NOT NULL	Whether validity checking can be deferred until run time: <p>B All checking must be performed during BIND.</p> <p>R Validation is done at run time for tables, views, and privileges that do not exist at bind time.</p>	G

⁴³ Plans are divided into *sections*. The base section of the plan must be in the EDM pool during the entire time the application program is executing. Other sections of the plan, corresponding roughly to sets of related SQL statements, are brought into the pool as needed.

Column name	Data type	Description	Use
ISOLATION	CHAR(1) NOT NULL	Isolation level for the plan: R RR (repeatable read) T RS (read stability) S CS (cursor stability) U UR (uncommitted read)	G
VALID	CHAR(1) NOT NULL	Whether the application plan is valid: A An ALTER TABLE statement changed the description of the table or base table of a view that is referred to by the application plan. For a CREATE INDEX statement involving data sharing, VALID is also marked as "A". H An ALTER TABLE statement changed the description of the table or base table of a view that is referred to by the application plan. N No Y Yes	G
OPERATIVE	CHAR(1) NOT NULL	Whether the application plan can be allocated: N No; an explicit BIND or REBIND is required before the plan can be allocated Y Yes	G
BINDTIME	CHAR(8) NOT NULL	Not used.	N
PLSIZE	INTEGER NOT NULL	Size of the base section ⁴³ of the plan, in bytes.	G
IBMREQD	CHAR(1) NOT NULL	A value of Y indicates that the row was provided with the Db2 product code. For all other values, see Release dependency indicators . The value in this field is not a reliable indicator of release dependencies. RELBOUND should be used instead.	G
AVGSIZE	INTEGER NOT NULL	Average size, in bytes, of those sections ⁴³ of the plan that contain SQL statements processed at bind time.	G

Column name	Data type	Description	Use
ACQUIRE	CHAR(1) NOT NULL	When resources are acquired: A At allocation U At first use	G
RELEASE	CHAR(1) NOT NULL	When resources are released: C At commit D At deallocation	G
EXREFERENCE	CHAR(1) NOT NULL	Not used.	N
EXSTRUCTURE	CHAR(1) NOT NULL	Not used.	N
EXCOST	CHAR(1) NOT NULL	Not used.	N
EXPLAN	CHAR(1) NOT NULL	EXPLAIN option specified for the plan; that is, whether information on the plan's statements was added to the owner's PLAN_TABLE table: N No Y Yes	G
EXPREDICATE	CHAR(1) NOT NULL	Indicates the CURRENTDATA option when the plan was bound or rebound: B Data currency is not required for ambiguous cursors. Allow blocking for ambiguous cursors. C Data currency is required for ambiguous cursors. Inhibit blocking for ambiguous cursors. N Blocking is inhibited for ambiguous cursors, but the plan was created before the CURRENTDATA option was available.	G
BOUNDBY	VARCHAR(128) NOT NULL WITH DEFAULT	Primary authorization ID of the binder of the plan.	G
QUALIFIER	VARCHAR(128) NOT NULL WITH DEFAULT	Implicit qualifier for the unqualified table, view, index, and alias names in the static SQL statements of the plan.	G

Column name	Data type	Description	Use
CACHESIZE	SMALLINT NOT NULL WITH DEFAULT	Size, in bytes, of the cache to be acquired for the plan. A value of zero indicates that no cache is used.	G
PLENTRIES	SMALLINT NOT NULL WITH DEFAULT	Number of package list entries for the plan. The negative of that number if there are rows for the plan in SYSIBM.SYSPACKLIST but the plan was bound in a prior release after fall back.	G
DEFERPREP	CHAR(1) NOT NULL WITH DEFAULT	Whether the package was last bound with the DEFER(PREPARE) option: N No Y Yes	G
CURRENTSERVER	VARCHAR(128) NOT NULL WITH DEFAULT	Location name specified with the CURRENTSERVER option when the plan was last bound. Blank if none was specified, implying that the first server is the local Db2 subsystem.	G
SYSENTRIES	SMALLINT NOT NULL WITH DEFAULT	Number of rows associated with the plan in SYSIBM.SYSPSYSTEM. The negative of that number if such rows exist but the plan was bound in a prior release after fall back. A negative value or zero means that all connections are enabled.	G
DEGREE	CHAR(3) NOT NULL WITH DEFAULT	The DEGREE option used when the plan was last bound: ANY DEGREE(ANY) 1 or blank DEGREE(1). Blank if the plan was migrated.	G
SQLRULES	CHAR(1) NOT NULL WITH DEFAULT	The SQLRULES option used when the plan was last bound: D or blank SQLRULES(DB2) S SQLRULES(STD) blank A migrated plan	G
DISCONNECT	CHAR(1) NOT NULL WITH DEFAULT	The DISCONNECT option used when the plan was last bound: E or blank DISCONNECT(EXPLICIT) A DISCONNECT(AUTOMATIC) C DISCONNECT(CONDITIONAL) blank A migrated plan	G

Column name	Data type	Description	Use
GROUP_MEMBER	VARCHAR(24) NOT NULL WITH DEFAULT	The Db2 data sharing member name of the Db2 subsystem that performed the most recent bind. This column is blank if the Db2 subsystem was not in a Db2 data sharing environment when the bind was performed.	G
DYNAMICRULES	CHAR(1) NOT NULL WITH DEFAULT	The DYNAMICRULES option used when the plan was last bound: B BIND. Dynamic SQL statements are executed with DYNAMICRULES bind behavior. blank RUN. Dynamic SQL statements in the plan are executed with DYNAMICRULES run behavior.	G
BOUNDTS	TIMESTAMP NOT NULL WITH DEFAULT	Time when the plan was bound.	G
REOPTVAR	CHAR(1) NOT NULL WITH DEFAULT 'N'	Whether the access path is determined again at execution time using input variable values: A Bind option REOPT(AUTO) indicates that the access path is determined multiple times at execution time depending on the parameter value. N Bind option REOPT(NONE) indicates that the access path is determined at bind time. Y Bind option REOPT(ALWAYS) indicates that the access path is determined at execution time for SQL statements with variable values. 1 Bind option REOPT(ONCE) indicates that the access path is determined only once at execution time, using the first set of input variable values, regardless of how many times the same statement is executed.	G
KEEPDYNAMIC	CHAR(1) NOT NULL WITH DEFAULT 'N'	Whether prepared dynamic statements are to be purged at each commit point: N The bind option is KEEPDYNAMIC(NO). Prepared dynamic SQL statements are destroyed at commit or rollback. Y The bind option is KEEPDYNAMIC(YES). Prepared dynamic SQL statements are kept past commit or rollback.	G

Column name	Data type	Description	Use
PATHSCHEMAS	VARCHAR(2048) NOT NULL WITH DEFAULT	SQL path specified on the BIND or REBIND command that bound the plan. The path is used to resolve unqualified data type, function, and stored procedure names used in certain contexts. If the PATH bind option was not specified, the value in the column is a zero length string; however, Db2 uses a default SQL path of: SYSIBM, SYSFUN, SYSPROC, <i>plan qualifier</i> .	G
DBPROTOCOL	CHAR(1) NOT NULL WITH DEFAULT 'P'	Whether remote access for SQL with three-part names is implemented with DRDA or Db2 private protocol access: D DRDA P Db2 private protocol	G
FUNCTIONTS	TIMESTAMP NOT NULL WITH DEFAULT	Timestamp when the function was resolved. This value is set by the BIND and REBIND commands, but not by automatic rebinds (autobind).	G
OPTHINT	VARCHAR(128) NOT NULL WITH DEFAULT	Value of the OPTHINT bind option. Identifies rows in the <i>owner.PLAN_TABLE</i> to be used as input to Db2. Contains blanks if no rows in the <i>owner.PLAN_TABLE</i> are to be used as input.	G
ENCODING_CCSID	INTEGER NOT NULL WITH DEFAULT	The CCSID corresponding to the encoding scheme or CCSID as specified for the bind option ENCODING. The Encoding Scheme specified on the bind command: ccsid The specified or derived CCSID. 0 The default CCSID as specified on panel DSNTIPF at installation time. Used when the plan was bound prior to Version 7	G
IMMEDWRITE	CHAR(1) NOT NULL WITH DEFAULT	Indicates when writes of updated group buffer pool dependent pages are to be done. This option is only applicable for data sharing environments. N Bind option IMMEDIATEWRITE(NO) indicates normal write activity is done. Y Bind option IMMEDIATEWRITE(YES) indicates that immediate writes are done for updated group buffer pool dependent pages. 1 Bind option IMMEDIATEWRITE(PH1) indicates that updated group buffer pool dependent pages are written at or before phase 1 commit. blank A migrated package.	G

Column name	Data type	Description	Use
RELBOUND	CHAR(1) NOT NULL WITH DEFAULT	The release when the package was bound or rebound. blank Bound prior to Version 7 For all other values, see Release dependency indicators	G
CATENCODE	CHAR(1)	Not used.	N
REMARKS	VARCHAR(762) NOT NULL WITH DEFAULT	A character string provided by the user with the COMMENT statement.	G
CREATORTYPE	CHAR(1) NOT NULL WITH DEFAULT	Indicates the type of creator: blank Authorization ID L Role	G
ROUNDING	CHAR(1) NOT NULL WITH DEFAULT	The ROUNDING option used when the plan was last bound: C ROUND_CEILING D ROUND_DOWN F ROUND_FLOOR G ROUND_HALF_DOWN E ROUND_HALF_EVEN H ROUND_HALF_UP U ROUND_UP blank The plan was created in a Db2 release prior to Version 9.	G
LASTUSED	DATE NOT NULL WITH DEFAULT	Not used.	N
CONCUR_ACC_RES	CHAR(1) NOT NULL	Indicates the CONCURRENTACCESSRESOLUTION option when the package was bound or rebound: blank Not specified U USECURRENTLYCOMMITTED W WAITFOROUTCOME	G

Column name	Data type	Description	Use
PROGAUTH	CHAR(1) NOT NULL WITH DEFAULT 'D'	Indicates whether Db2 checks if a program is authorized to run a plan: D DISABLE E ENABLE	G

SYSPLANAUTH catalog table

The SYSPLANAUTH table records the privileges that are held by users over application plans. The schema is SYSIBM.

Column name	Data type	Description	Use
GRANTOR	VARCHAR(128) NOT NULL	Authorization ID of the user who granted the privileges.	G
GRANTEE	VARCHAR(128) NOT NULL	Authorization ID of the user who holds the privileges. Could also be PUBLIC for a grant to PUBLIC.	G
NAME	VARCHAR(24) NOT NULL	Name of the application plan on which the privileges are held.	G
—	CHAR(12) NOT NULL	Internal use only.	I
DATEGRANTED	CHAR(6) NOT NULL	Not used.	N
TIMEGRANTED	CHAR(8) NOT NULL	Not used.	N
GRANTEETYPE	CHAR(1) NOT NULL	Not used.	N

Column name	Data type	Description	Use
AUTHHOWGOT	CHAR(1) NOT NULL	<p>Authorization level of the user from whom the privileges were received. This authorization level is not necessarily the highest authorization level of the grantor.</p> <p>blank Not applicable</p> <p>C DBCTRL</p> <p>D DBADM</p> <p>E SECADM</p> <p>G ACCESSCTRL</p> <p>L SYSCTRL</p> <p>M DBMAINT</p> <p>S SYSADM</p>	G
BINDAUTH	CHAR(1) NOT NULL	<p>Whether the GRANTEE can use the BIND, REBIND, or FREE subcommands against the plan:</p> <p>blank Privilege is not held</p> <p>G Privilege is held with the GRANT option</p> <p>Y Privilege is held without the GRANT option</p>	G
EXECUTEAUTH	CHAR(1) NOT NULL	<p>Whether the GRANTEE can run application programs that use the application plan:</p> <p>blank Privilege is not held</p> <p>G Privilege is held with the GRANT option</p> <p>Y Privilege is held without the GRANT option</p>	G
IBMREQD	CHAR(1) NOT NULL	<p>A value of Y indicates that the row was provided with the Db2 product code. For all other values, see Release dependency indicators.</p> <p>The value in this field is not a reliable indicator of release dependencies.</p>	G
GRANTEDTS	TIMESTAMP NOT NULL WITH DEFAULT	Time when the GRANT statement was executed.	G

Column name	Data type	Description	Use
GRANTEETYPE	CHAR(1) NOT NULL WITH DEFAULT	Indicates the type of grantee: blank Authorization ID L Role	G
GRANTORTYPE	CHAR(1) NOT NULL WITH DEFAULT	Indicates the type of grantor: blank Authorization ID L Role	G
SYS_START	TIMESTAMP(12) NOT NULL GENERATED ALWAYS AS ROW BEGIN	Reserved for future IBM use.The row-begin column of the SYSTEM_TIME period, for system-period data versioning.	G
SYS_END	TIMESTAMP(12) NOT NULL GENERATED ALWAYS AS ROW END	Reserved for future IBM use.The row-end column of the SYSTEM_TIME period, for system-period data versioning.	G
TRANS_START	TIMESTAMP(12) NOT NULL GENERATED ALWAYS AS TRANSACTION START ID	Reserved for future IBM use.	G

SYSPLANDEP catalog table

The SYSPLANDEP table records the dependencies of plans on tables, views, aliases, synonyms, table spaces, indexes, functions, and stored procedures. The schema is SYSIBM.

Table 340. SYSIBM.SYSPLANDEP table column descriptions

Column name	Data type	Description	Use
BNAME	VARCHAR(128) NOT NULL	The name of an object the plan depends on.	G
BCREATOR	VARCHAR(128) NOT NULL	If BNAME is a table space, its database. Otherwise, the schema of BNAME. If BNAME is a role, the value is blank.	G

Table 340. SYSIBM.SYSPLANDEP table column descriptions (continued)

Column name	Data type	Description	Use
BTYPE	CHAR(1) NOT NULL	Type of object identified by BNAME: A Alias E INSTEAD OF trigger F User-defined function or cast function H Global variable G Global temporary table I Index M Materialized query table O Stored procedure P Partitioned table space if it is defined as LARGE or with the DSSIZE parm Q Sequence object R Table space S Synonym T Table V View	G
DNAME	VARCHAR(24) NOT NULL	Name of the plan.	G
IBMREQD	CHAR(1) NOT NULL	A value of Y indicates that the row was provided with the Db2 product code. For all other values, see Release dependency indicators . The value in this field is not a reliable indicator of release dependencies.	G

SYSPLSYSTEM catalog table

The SYSPLSYSTEM table contains zero or more rows for every plan. Each row for a given plan represents one or more connections to an environment in which the plan could be used. The schema is SYSIBM.

Table 341. SYSIBM.SYSPLSYSTEM table column descriptions

Column name	Data type	Description	Use
NAME	VARCHAR(24) NOT NULL	Name of the plan.	G
SYSTEM	VARCHAR(24) NOT NULL	Environment. Values can be: BATCH TSO batch DB2CALL Db2 call attachment facility CICS Customer Information Control System DLIBATCH DLI batch support facility IMSBMP IMS BMP region IMSMPP IMS MPP or IFP region	G
ENABLE	CHAR(1) NOT NULL	Indicates whether the connections represented by the row are enabled or disabled: N Disabled Y Enabled	G
CNAME	VARCHAR(60) NOT NULL	Identifies the connection or connections to which the row applies. Interpretation depends on the environment specified by SYSTEM. Values can be: <ul style="list-style-type: none">Blank if SYSTEM=BATCH or SYSTEM=DB2CALLThe name of a single connection if SYSTEM has any other value CNAME can also be blank when SYSTEM is not equal to BATCH or DB2CALL. When this is so, the row applies to all connections for the indicated environment.	G
IBMREQD	CHAR(1) NOT NULL	A value of Y indicates that the row was provided with the Db2 product code. For all other values, see Release dependency indicators . The value in this field is not a reliable indicator of release dependencies.	G

SYSQUERY catalog table

Each SYSIBM.SYSQUERY table row identifies a SQL statement. The information is used to influence access path selection when matching statements are optimized. The schema is SYSIBM.

Column name	Data type	Description	Use
QUERYID	BIGINT NOT NULL GENERATED BY DEFAULT AS IDENTITY	Unique identifier for the query.	G
QUERY_HASH	CHAR(16) NOT NULL FOR BIT DATA	The hash key generated by statement text.	G
SCHEMA	VARCHAR(128) NOT NULL	The default schema name for unqualified objects in the query or blank. If the query contains unqualified objects and access path hints exist for the query, the access path hints are applied only if the default schema matches the schema in the access path hint.	G
QUERY_SEC_HASH	CHAR(16) NOT NULL FOR BIT DATA	The hash key generated by the modified statement text.	G
QUERY_HASH_VERSION	INTEGER NOT NULL	The version of the query hash.	G
SOURCE	SMALLINT NOT NULL	The source of the row: 0 Statement-level optimization hints.	G
USERFILTER	CHAR(8) NOT NULL	Filter name that is used to group a set of queries or blank.	G
—	CHAR(128) NOT NULL	Internal use only.	I
PLAN_VALID	CHAR(1) NOT NULL	Whether plan hints are valid: blank No access path is specified for the statement, but optimization parameters exist in SYSQUERYOPTS Y An access path is specified in SYSQUERYPLAN for the statement. The access path is also valid if the statement has already been executed and the access path was used. N An access path is specified in SYSQUERYPLAN, but the access path is invalid and not used.	G

Column name	Data type	Description	Use
INVALID_REASON	INTEGER NOT NULL	When PLAN_VALID is N, this column contains the reason that the access path is invalid. If PLAN_VALID is Y or blank, this column contains -1. For descriptions of the reason code values, see: +395 (Db2 Codes) .	S
LOCATION	VARCHAR(128) NOT NULL	Not used.	N
COLLECTION	VARCHAR(128) NOT NULL	Name of the collection of the originating query or blank.	G
PACKAGE	VARCHAR(128) NOT NULL	Name of the package of the originating query or blank.	G
VERSION	VARCHAR(128) NOT NULL	Version of the package or blank.	G
AUTHID	VARCHAR(128) NOT NULL	Authorization ID this was in effect when the query was captured or blank.	G
BINDTIME	TIMESTAMP NOT NULL	Timestamp when the package was bound or when BIND QUERY was run	G
RELBOUND	CHAR(1) NOT NULL	The release of Db2 in which the package was bound, or blank. See Release dependency indicators for values.	G
IBMREQD	CHAR(1) NOT NULL	A value of Y indicates that the row was provided with the Db2 product code. For all other values, see Release dependency indicators . The value in this field is not a reliable indicator of release dependencies. RELBOUND should be used instead.	G
STMTNO	INTEGER NOT NULL	The statement number in the package. -1 when not applicable.	G
SECTNO	INTEGER NOT NULL	The section number in the package. -1 when not applicable.	G
STMTTEXT	CLOB(2M) INLINE LENGTH 2048	The text of the matching SQL statement. The value is populated from the value of the QUERY_TEXT column of the DSN_USERQUERY_TABLE table, with the following items removed: <ul style="list-style-type: none"> • Blanks including leading and trailing blanks, and embedded blanks that are not within literal strings between pairs of quotation mark symbols • White space, including leading and trailing white space, and white space that is not within a literal string between a pair of quotation mark symbols • SQL comments • EXPLAIN clauses 	G

Column name	Data type	Description	Use
QUERYNO	INTEGER NOT NULL WITH DEFAULT '-1'	The query number.	G
CLIENT_USERID	VARCHAR(255)	User ID of the client.	G
CLIENT_WRKSTNNAME	VARCHAR(255)	Name of the client workstation.	G
CLIENT_APPLNAME	VARCHAR(255)	Name of the client application.	G
SELECTVTY_OVERRIDE	CHAR(1) NOT NULL	Whether selectivity overrides are in effect for the query: 'Y' Selectivity overrides are in effect 'N' Selectivity overrides are not in effect.	G
ACCESSPATH_HINT	CHAR(1) NOT NULL	Whether access paths are specified for the matching statements: 'Y' An access paths is specified and in effect 'N' An access path hints is specified and in effect blank An access path might be specified. When the value is blank you must query the SYSIBM.SYSQUERYPLAN catalog table to determine whether an access path is specified	G
OPTION_OVERRIDE	CHAR(1) NOT NULL	Whether statement-level optimization parameters are in effect for matching statements: 'Y' Optimization parameters are in effect. 'N' Optimization parameters are not in effect. blank Optimization parameters might be in effect. When the value is blank you must query the SYSIBM.SYSQUERYOPTS catalog table to determine whether option overrides are in effect.	G

Column name	Data type	Description	Use
SELECTIVITY_VALID	CHAR(1) NOT NULL	Whether selectivity overrides are valid: blank No selectivity overrides exist for the statement. 'Y' Selectivity overrides exist for the query. The overrides are valid if the statement has already been executed and the overrides were used. 'N' Selectivity overrides exist but the overrides are invalid and not used.	G
FUNCTION_LVL	VARCHAR(10)	The function level of the query.	G

Related tasks

[Influencing access path selection \(Db2 Performance\)](#)

Related reference

[Tables for influencing access path selection \(Db2 Performance\)](#)

SYSQUERYOPTS catalog table

The SYSQUERYOPTS table contains optimization parameters for the queries that are in the SYSQUERY table. The schema is SYSIBM.

Table 342. SYSIBM.SYSQUERYOPTS table column descriptions

Column name	Data type	Description	Use
QUERYID	BIGINT NOT NULL ON DELETE CASCADE	Unique identifier for the query. This column corresponds to the QUERYID column in the SYSIBM.SYSQUERY table.	G
COPYID	SMALLINT NOT NULL	The version of the plan hints for the query in this row. 0 Current version of the plan hints. 1 Previous version of the plan hints used by PLAN STABILITY 2 Original version of the plan hints used by PLAN STABILITY	G

Table 342. SYSIBM.SYSQUERYOPTS table column descriptions (continued)

Column name	Data type	Description	Use
REOPT	CHAR(1) NOT NULL	The value of the REOPT bind option that is in effect for the plan: 1 REOPT(ONCE) A REOPT(AUTO) N REOPT(NONE) Y REOPT(ALWAYS) blank REOPT is not specified	G
STARJOIN	CHAR(1) NOT NULL	Whether star join is enabled: Y Star join is enabled N Star join is disabled blank Star join is not specified	G
MAX_PAR_DEGREE	INTEGER NOT NULL	The maximum parallel degree. This column will contain a value in the range 0–254. If the value of the column is -1, the maximum parallel degree is not specified.	G
DEF_CURR_DEGREE	CHAR(3) NOT NULL	Whether query parallelism is enabled: ONE Query parallelism is disabled ANY Query parallelism is enabled blank Query parallelism is disabled	G
SJTABLES	INTEGER NOT NULL	The number of tables specified in a query to qualify for star join processing. If this column contains -1, star join processing is not specified.	G
—	VARCHAR(128) NOT NULL	Internal use only.	I
GROUP_MEMBER	VARCHAR(24) NOT NULL	The group member name to which the parameters are to be applied. This column contains blank if the group member name is not specified.	G
IBMREQD	CHAR(1) NOT NULL	A value of Y indicates that the row was provided with the Db2 product code. For all other values, see Release dependency indicators . The value in this field is not a reliable indicator of release dependencies.	G

Related tasks

[Specifying optimization parameters at the statement level \(Db2 Performance\)](#)

Related reference

[Tables for influencing access path selection \(Db2 Performance\)](#)

[DSN_USERQUERY_TABLE \(Db2 Performance\)](#)

SYSQUERYPLAN catalog table

The SYSQUERYPLAN table contains the plan hint information for the queries in the SYSIBM.SYSQUERY table. It correlates to the SYSQUERY table by the QUERYID column. For a query, there can be up to 3 copies of plan hints stored in the SYSQUERYPLAN table, distinguished by the value of the COPYID column. The schema is SYSIBM.

Table 343. SYSIBM.SYSQUERYPLAN table column descriptions

Column name	Data type	Description	Use
QUERYID	BIGINT NOT NULL ON DELETE CASCADE	Unique identifier for the query. The value of QUERYID corresponds to the value of the QUERYID column in the SYSIBM.SYSQUERY column.	G
COPYID	SMALLINT NOT NULL	The version of the plan hints for the query in this row. 0 Current version of the plan hints. 1 Previous version of the plan hints used by PLAN STABILITY 2 Original version of the plan hints used by PLAN STABILITY	G
PLAN_VALID	CHAR(1) NOT NULL	Whether the plan hints are valid: N The plan hints are invalid Y The plan hints are valid	G
IBMREQD	CHAR(1) NOT NULL	A value of Y indicates that the row was provided with the Db2 product code. For all other values, see Release dependency indicators . The value in this field is not a reliable indicator of release dependencies.	G
QBLOCKNO	SMALLINT NOT NULL	A number that identifies each query block within a query. The value of the numbers are not in any particular order, nor are they necessarily consecutive.	G
PLANNO	SMALLINT NOT NULL	The number of the step in which the query that is indicated in QBLOCKNO was processed. This column indicates the order in which the steps were executed.	G

Table 343. SYSIBM.SYSQUERYPLAN table column descriptions (continued)

Column name	Data type	Description	Use
METHOD	SMALLINT NOT NULL	<p>A number that indicates the join method that is used for the step:</p> <p>0 The table in this step is the first table that is accessed, a continuation of a previous table that was accessed, or a table that is not used.</p> <p>1 A nested loop join is used. For each row of the current composite table, matching rows of a new table are found and joined.</p> <p>2 A merge scan join is used. The current composite table and the new table are scanned in the order of the join columns, and matching rows are joined.</p> <p>3 Sorts are needed by ORDER BY, GROUP BY, SELECT DISTINCT, UNION, INTERSECT, EXCEPT, a quantified predicate, or an IN predicate. This step does not access a new table.</p> <p>4 A hybrid join was used. The current composite table is scanned in the order of the join-column rows of the new table. The new table is accessed using list prefetch.</p>	G
CREATOR	VARCHAR(128) NOT NULL	The creator of the new table that is accessed in this step, blank if METHOD is 3.	G
TNAME	VARCHAR(128) NOT NULL	<p>The name of one of the following objects:</p> <ul style="list-style-type: none"> • Materialized query table • Created or declared temporary table • Materialized view • materialized table expression <p>The value is blank if METHOD is 3. The column can also contain the name of a table in the form DSNWFQB(<i>qblockno</i>). DSNWFQB(<i>qblockno</i>) is used to represent the intermediate result of a UNION ALL, INTERSECT ALL, EXCEPT ALL, or an outer join that is materialized. If a view is merged, the name of the view does not appear. DSN_DIM_TBLX(<i>qblockno</i>) is used to represent the work file of a star join dimension table.</p>	G
—	SMALLINT NOT NULL	Internal use only.	I

Table 343. SYSIBM.SYSQUERYPLAN table column descriptions (continued)

Column name	Data type	Description	Use
ACCESSTYPE	CHAR(2) NOT NULL	<p>The method of accessing the new table:</p> <p>A Accelerated query table access.</p> <p>DI By an intersection of multiple DOCID lists to return the final DOCID list</p> <p>DU By a union of multiple DOCID lists to return the final DOCID list</p> <p>DX By an XML index scan on the index that is named in ACCESSNAME to return a DOCID list</p> <p>E By direct row access using a row change timestamp column.</p> <p>H By hash overflow index (identified in ACCESSCREATOR and ACCESSNAME)</p> <p>I By an index (identified in ACCESSCREATOR and ACCESSNAME)</p> <p>IN By an index scan when the matching predicate contains an IN predicate and the IN-list is accessed through an in-memory table.</p> <p>I1 By a one-fetch index scan</p> <p>M By a multiple index scan (followed by MX, MI, MU, or MH)</p> <p>MH By the hash overflow index named in ACCESSNAME</p> <p>MI By an intersection of multiple indexes</p> <p>MU By a union of multiple indexes</p> <p>MX By an index scan on the index named in ACCESSNAME. When the access method MX follows the access method DX, DI, or DU, the table is accessed by the DOCID index by using the DOCID list that is returned by DX, DI, or DU.</p>	G

Table 343. SYSIBM.SYSQUERYPLAN table column descriptions (continued)

Column name	Data type	Description	Use
ACCESSTYPE (continued)		<p>N</p> <ul style="list-style-type: none"> By an index scan when the matching predicate contains the IN keyword By an index scan when Db2 rewrites a query using the IN keyword By hash access with the IN keyword By hash access when Db2 rewrites a query using the IN keyword <p>NR Range list access.</p> <p>P By a dynamic pair-wise index scan</p> <p>R By a table space scan</p> <p>RW By a work file scan of the result of a materialized user-defined table function</p> <p>V By buffers for an INSERT statement within a SELECT</p> <p>blank Not applicable to the current row</p>	
MATCHCOLS	SMALLINT NOT NULL	For ACCESSTYPE I, I1, N, NR, MX, or DX, the number of index keys that are used in an index scan; otherwise, 0.	G
ACCESSCREATOR	VARCHAR(128) NOT NULL	For ACCESSTYPE I, I1, N, NR, MX, or DX, the creator of the index; otherwise, blank.	G
ACCESSNAME	VARCHAR(128) NOT NULL	For ACCESSTYPE I, I1, H, MH, N, NR, MX, or DX, the name of the index; for ACCESSTYPE P, DSNPJW(<i>mixopseqno</i>) is the starting pair-wise join leg in MIXOPSEQNO; otherwise, blank.	G
INDEXONLY	CHAR(1) NOT NULL	<p>Indication of whether access to an index alone is enough to perform the step, or Indication of whether data too must be accessed.</p> <p>Y Yes</p> <p>N No</p>	G
SORTN_UNIQ	CHAR(1) NOT NULL	<p>Indication of whether the new table is sorted to remove duplicate rows.</p> <p>Y Yes</p> <p>N No</p>	G

Table 343. SYSIBM.SYSQUERYPLAN table column descriptions (continued)

Column name	Data type	Description	Use
SORTN_JOIN	CHAR(1) NOT NULL	Indication of whether the new table is sorted for join method 2 or 4. Y Yes N No	G
SORTN_ORDERBY	CHAR(1) NOT NULL	Indication of whether the new table is sorted for ORDER BY. Y Yes N No	G
SORTN_GROUPBY	CHAR(1) NOT NULL	Indication of whether the new table is sorted for GROUP BY. Y Yes N No	G
SORTC_UNIQ	CHAR(1) NOT NULL	Indication of whether the composite table is sorted to remove duplicate rows. Y Yes N No	G
SORTC_JOIN	CHAR(1) NOT NULL	Indication of whether the composite table is sorted for join method 1, 2 or 4. Y Yes N No	G
SORTC_ORDERBY	CHAR(1) NOT NULL	Indication of whether the composite table is sorted for an ORDER BY clause or a quantified predicate. Y Yes N No	G
SORTC_GROUPBY	CHAR(1) NOT NULL	Indication of whether the composite table is sorted for a GROUP BY clause. Y Yes N No	G

Table 343. SYSIBM.SYSQUERYPLAN table column descriptions (continued)

Column name	Data type	Description	Use
TSLOCKMOD	CHAR(3) NOT NULL	<p>An indication of the mode of lock that is acquired on either the new table, or its table space or table space partitions. If the isolation can be determined at bind time, the values are:</p> <p>IS Intent share lock</p> <p>IX Intent exclusive lock</p> <p>S Share lock</p> <p>U Update lock</p> <p>X Exclusive lock</p> <p>SIX Share with intent exclusive lock</p> <p>N UR isolation; no lock</p> <p>If the isolation level cannot be determined at bind time, the lock mode is determined by the isolation level at run time is shown by the following values.</p> <p>NS For UR isolation, no lock; for CS, RS, or RR, an S lock.</p> <p>NIS For UR isolation, no lock; for CS, RS, or RR, an IS lock.</p> <p>NSS For UR isolation, no lock; for CS or RS, an IS lock; for RR, an S lock.</p> <p>SS For UR, CS, or RS isolation, an IS lock; for RR, an S lock.</p> <p>The data in this column is right justified. For example, IX appears as a blank, followed by I, followed by X. If the column contains a blank, then no lock is acquired.</p> <p>If the access method in the ACCESTYPE column is DX, DI, or DU, no latches are acquired on the XML index page and no lock is acquired on the new base table data page or row, nor on the XML table and the corresponding table spaces. The value of TSLOCKMODE is a blank in this case.</p>	G

Table 343. SYSIBM.SYSQUERYPLAN table column descriptions (continued)

Column name	Data type	Description	Use
PREFETCH	CHAR(1) NOT NULL	Indication of whether data pages are to be read in advance by prefetch: D Optimizer expects dynamic prefetch S Pure sequential prefetch L Prefetch through a page list blank Unknown or no prefetch	G
COLUMN_FN_EVAL	CHAR(1) NOT NULL	When an SQL aggregate function is evaluated: R While the data is being read from the table or index S While performing a sort to satisfy a GROUP BY clause blank After data retrieval and after any sorts	G
MIXOPSEQ	SMALLINT NOT NULL	The sequence number of a step in a multiple index operation. 1, 2, ... n For the steps of the multiple index procedure (ACCESSTYPE is MX, MI, MU, DX, DI, or DU), or the sequence number of range list access (ACCESSTYPE is 'NR'). 0 For any other rows.	G
ACCESS_DEGREE	SMALLINT	The number of parallel tasks or operations that are activated by a query. This value is determined at bind time; the actual number of parallel operations that are used at execution time could be different. This column contains 0 if a host variable is used. This column contains the null value if the plan or package was bound using a plan table with fewer than 43 columns. Otherwise, it can contain null if the method that it refers to does not apply.	G
ACCESS_PGROUP_ID	SMALLINT	The identifier of the parallel group for accessing the new table. A parallel group is a set of consecutive operations, executed in parallel, that have the same number of parallel tasks. This value is determined at bind time; it could change at execution time. This column contains the null value if the plan or package was bound using a plan table with fewer than 43 columns. Otherwise, it can contain null if the method that it refers to does not apply.	G

Table 343. SYSIBM.SYSQUERYPLAN table column descriptions (continued)

Column name	Data type	Description	Use
JOIN_DEGREE	SMALLINT	The number of parallel operations or tasks that are used in joining the composite table with the new table. This value is determined at bind time and can be 0 if a host variable is used. The actual number of parallel operations or tasks used at execution time could be different. This column contains the null value if the plan or package was bound using a plan table with fewer than 43 columns. Otherwise, it can contain null if the method that it refers to does not apply.	G
JOIN_PGROUP_ID	SMALLINT	The identifier of the parallel group for joining the composite table with the new table. This value is determined at bind time; it could change at execution time. This column contains the null value if the plan or package was bound using a plan table with fewer than 43 columns. Otherwise, it can contain null if the method that it refers to does not apply.	G
SORTC_PGROUP_ID	SMALLINT	The parallel group identifier for the parallel sort of the composite table. This column contains the null value if the plan or package was bound using a plan table with fewer than 43 columns. Otherwise, it can contain null if the method that it refers to does not apply.	G
SORTN_PGROUP_ID	SMALLINT	The parallel group identifier for the parallel sort of the new table. This column contains the null value if the plan or package was bound using a plan table with fewer than 43 columns. Otherwise, it can contain null if the method that it refers to does not apply.	G
PARALLELISM_MODE	CHAR(1)	The kind of parallelism, if any, that is used at bind time: I Query I/O parallelism C Query CP parallelism This column contains the null value if the plan or package was bound using a plan table with fewer than 43 columns. Otherwise, it can contain null if the method that it refers to does not apply.	G
MERGE_JOIN_COLS	SMALLINT	The number of columns that are joined during a merge scan join (Method=2). This column contains the null value if the plan or package was bound using a plan table with fewer than 43 columns. Otherwise, it can contain null if the method that it refers to does not apply.	G
CORRELATION_NAME	VARCHAR(128)	The correlation name of a table or view that is specified in the statement. If no correlation name exists, then the column is null. This column contains the null value if the plan or package was bound using a plan table with fewer than 43 columns. Otherwise, it can contain null if the method that it refers to does not apply.	G

Table 343. SYSIBM.SYSQUERYPLAN table column descriptions (continued)

Column name	Data type	Description	Use
PAGE_RANGE	CHAR(1) NOT NULL WITH DEFAULT	Indication of whether the table qualifies for page range screening, so that plans scan only the partitions that are needed. Y Yes blank No	G
JOIN_TYPE	CHAR(1) NOT NULL WITH DEFAULT	The type of join: F FULL OUTER JOIN L LEFT OUTER JOIN P Pair-wise join S Star join blank INNER JOIN or no join RIGHT OUTER JOIN converts to a LEFT OUTER JOIN when you use it, so that JOIN_TYPE contains L.	G

Table 343. SYSIBM.SYSQUERYPLAN table column descriptions (continued)

Column name	Data type	Description	Use
QBLOCK_TYPE	CHAR(6) NOT NULL WITH DEFAULT	<p>For each query block, an indication of the type of SQL operation that is performed. For the outermost query, this column identifies the statement type. Possible values include:</p> <p>SELECT SELECT</p> <p>INSERT INSERT</p> <p>UPDATE UPDATE</p> <p>MERGE MERGE</p> <p>DELETE DELETE</p> <p>SELUPD SELECT with FOR UPDATE OF</p> <p>DELCUR DELETE WHERE CURRENT OF CURSOR</p> <p>UPDCUR UPDATE WHERE CURRENT OF CURSOR</p> <p>CORSUB Correlated subselect or fullselect</p> <p>TRUNCA TRUNCATE</p> <p>NCOSUB Noncorrelated subselect or fullselect</p> <p>TABLEX Table expression</p> <p>TRIGGR WHEN clause on CREATE TRIGGER</p> <p>UNION UNION</p> <p>UNIONA UNION ALL</p> <p>INTERS INTERSECT</p> <p>INTERA INTERSECT ALL</p> <p>EXCEPT EXCEPT</p> <p>EXCEPTA EXCEPT ALL</p>	G

Table 343. SYSIBM.SYSQUERYPLAN table column descriptions (continued)

Column name	Data type	Description	Use
PRIMARY_ ACCESSTYPE	CHAR(1) NOT NULL WITH DEFAULT	<p>Indicates Indication of whether direct row access is attempted first:</p> <p>D Db2 tries to use direct row access with a rowid column. If Db2 cannot use direct row access with a rowid column at run time, it uses the access path that is described in the ACCESSTYPE column of PLAN_TABLE.</p> <p>T The base table or result file is materialized into a work file, and the work file is accessed via sparse index access. If a base table is involved, then ACCESSTYPE indicates how the base table is accessed.</p> <p>blank Db2 does not try to use direct row access by using a rowid column or sparse index access for a work file. The value of the ACCESSTYPE column of PLAN_TABLE provides information on the method of accessing the table.</p>	G
PARENT_QBLOCKNO	SMALLINT NOT NULL	A number that indicates the QBLOCKNO of the parent query block.	G

Table 343. SYSIBM.SYSQUERYPLAN table column descriptions (continued)

Column name	Data type	Description	Use
TABLE_TYPE	CHAR(1)	<p>The type of new table:</p> <p>B Buffers for SELECT from INSERT, SELECT from UPDATE, SELECT from MERGE, or SELECT from DELETE statement.</p> <p>C Common table expression</p> <p>F Table function</p> <p>I The new table is generated from an IN-LIST predicate. If the IN-LIST predicate is selected as the matching predicate, it will be accessed as an in-memory table.</p> <p>M Materialized query table</p> <p>Q Temporary intermediate result table (not materialized). For the name of a view or nested table expression, a value of Q indicates that the materialization was virtual and not actual. Materialization can be virtual when the view or nested table expression definition contains a UNION ALL that is not distributed.</p> <p>R Recursive common table expression</p> <p>S Subquery (correlated or non-correlated)</p> <p>T Table</p> <p>W Work file</p> <p>The value of the column is null if the query uses GROUP BY, ORDER BY, or DISTINCT, which requires an implicit sort.</p>	G
TABLE_ENCODE	CHAR(1)	<p>The encoding scheme of the table. The possible values are:</p> <p>A ASCII</p> <p>E EBCDIC</p> <p>U Unicode</p> <p>M The table contains multiple CCSID sets</p>	G

Table 343. SYSIBM.SYSQUERYPLAN table column descriptions (continued)

Column name	Data type	Description	Use
TABLE_SCCSID	SMALLINT NOT NULL WITH DEFAULT	The SBCS CCSID value of the table. If column TABLE_ENCODE is M, the value is 0.	G
TABLE_MCCSID	SMALLINT NOT NULL WITH DEFAULT	The mixed CCSID value of the table. If the value of the TABLE_ENCODE column is M, the value is 0. If MIXED=NO in the DSNHDECP module, the value is -2.	G
TABLE_DCCSID	SMALLINT NOT NULL WITH DEFAULT	The DBCS CCSID value of the table. If the value of the TABLE_ENCODE column is M, the value is 0. If MIXED=NO in the DSNHDECP module, the value is -2.	G
	INTEGER NOT NULL WITH DEFAULT	The values in this column are for IBM use only.	I
CTEREF	SMALLINT NOT NULL WITH DEFAULT	If the referenced table is a common table expression, the value is the top-level query block number.	G
PARENT_PLANNO	SMALLINT NOT NULL	Corresponds to the plan number in the parent query block where a correlated subquery is invoked. Or, for non-correlated subqueries, corresponds to the plan number in the parent query block that represents the work file for the subquery.	G

Table 343. SYSIBM.SYSQUERYPLAN table column descriptions (continued)

Column name	Data type	Description	Use
EXPANSION_REASON	CHAR(2) NOT NULL	<p>This column applies to only static statements that reference archive tables or temporal tables. For other statements, this column is blank.</p> <p>Indicates the effect of the CURRENT TEMPORAL BUSINESS_TIME special register, the CURRENT TEMPORAL SYSTEM_TIME special register, and the SYSIBMADM.GET_ARCHIVE built-in global variable. These items are controlled by the BUSTIMESENSITIVE, SYSTIMESENSITIVE, and ARCHIVESENSITIVE bind options.</p> <p>If one of these special registers or the global variable is set to Y and the corresponding bind option is set to YES, Db2 implicitly adds certain syntax to the statement. This column indicates whether the query contains this implicit query transformation and why.</p> <p>This column can have one of the following values:</p> <p>A The query contains implicit query transformation as a result of the SYSIBMADM.GET_ARCHIVE built-in global variable.</p> <p>B The query contains implicit query transformation as a result of the CURRENT TEMPORAL BUSINESS_TIME special register.</p> <p>S The query contains implicit query transformation as a result of the CURRENT TEMPORAL SYSTEM_TIME special register.</p> <p>SB The query contains implicit query transformation as a result of the CURRENT TEMPORAL SYSTEM_TIME special register and the CURRENT TEMPORAL BUSINESS_TIME special register.</p> <p>blank The query does not contain implicit query transformation.</p> <p>Related information</p> <p>“GET_ARCHIVE” on page 330</p> <p>“CURRENT TEMPORAL BUSINESS_TIME special register” on page 208</p> <p>“CURRENT TEMPORAL SYSTEM_TIME special register” on page 210</p> <p>BIND and REBIND options for packages, plans, and services (Db2 Commands)</p>	G

Related tasks

[Specifying access paths at the statement level \(Db2 Performance\)](#)

Related reference

Tables for influencing access path selection (Db2 Performance)

PLAN_TABLE (Db2 Performance)

SYSQUERYPREDICATE catalog table

The SYSQUERYPREDICATE table contains information about predicates for queries in the SYSQUERY table that have been identified for extended optimization. It correlates to the SYSQUERY table by the QUERYID column. The schema is SYSIBM.

Table 344. SYSIBM.SYSQUERYPREDICATE table column descriptions

Column name	Data type	Description	Use
QUERYID	BIGINT	Identifier of the query.	S
QUERYNO	INTEGER NOT NULL	<p>A number that identifies the statement that is being explained. The origin of the value depends on the context of the row:</p> <p>For rows produced by EXPLAIN statements The number specified in the QUERYNO clause, which is an optional part of the SELECT, INSERT, UPDATE, MERGE, and DELETE statement syntax.</p> <p>For rows not produced by EXPLAIN statements Db2 assigns a number that is based on the line number of the SQL statement in the source program.</p> <p>When the values of QUERYNO are based on the statement number in the source program, values that exceed 32767 are reported as 0. However, in certain rare cases, the value is not guaranteed to be unique.</p>	S
QBLOCKNO	SMALLINT NOT NULL	A number that identifies each query block within a query. The value of the numbers are not in any particular order, nor are they necessarily consecutive.	S
APPLNAME	VARCHAR(24) NOT NULL	The name of the application plan for the row. Applies only to embedded EXPLAIN statements that are executed from a plan or to statements that are explained when binding a plan. A blank indicates that the column is not applicable.	S
PROGNAME	VARCHAR(128) NOT NULL	The name of the program or package containing the statement being explained. Applies only to embedded EXPLAIN statements and to statements explained as the result of binding a plan or package. A blank indicates that the column is not applicable.	S
PREDNO	INTEGER NOT NULL	The predicate number, a number used to identify a predicate within a query.	S

Table 344. SYSIBM.SYSQUERYPREDICATE table column descriptions (continued)

Column name	Data type	Description	Use
TYPE	CHAR(8) NOT NULL	<p>A string used to indicate the type or the operation of the predicate. The possible values are:</p> <ul style="list-style-type: none"> • 'AND' • 'OR' • 'EQUAL' • 'RANGE' • 'BETWEEN' • 'IN' • 'LIKE' • 'NOT LIKE' • 'EXISTS' • 'NOTEXIST' • 'SUBQUERY' • 'HAVING' • 'OTHERS' 	S
LEFT_HAND_SIDE	VARCHAR(128) NOT NULL	<p>If the LHS of the predicate is a table column (LHS_TABNO > 0), then this column indicates the column name. Other possible values are:</p> <ul style="list-style-type: none"> • 'VALUE' • 'COLEXP' • 'NONCOLEXP' • 'CORSUB' • 'NONCORSUB' • 'SUBQUERY' • 'EXPRESSION' • Blanks 	S
LEFT_HAND_PNO	INTEGER NOT NULL	<p>If the LHS of the predicate is a table column (LHS_TABNO > 0), then this column indicates the column name. Other possible values are:</p> <ul style="list-style-type: none"> • 'VALUE' • 'COLEXP' • 'NONCOLEXP' • 'CORSUB' • 'NONCORSUB' • 'SUBQUERY' • 'EXPRESSION' • Blanks 	S
LHS_TABNO	SMALLINT NOT NULL	<p>If the LHS of the predicate is a table column, then this column indicates a number which uniquely identifies the corresponding table reference within a query.</p>	S

Table 344. SYSIBM.SYSQUERYPREDICATE table column descriptions (continued)

Column name	Data type	Description	Use
LHS_QBNO	SMALLINT NOT NULL	If the LHS of the predicate is a table column, then this column indicates a number which uniquely identifies the corresponding table reference within a query.	S
RIGHT_HAND_SIDE	VARCHAR(128) NOT NULL	If the RHS of the predicate is a table column (RHS_TABNO > 0), then this column indicates the column name. Other possible values are: <ul style="list-style-type: none"> • 'VALUE' • 'COLEXP' • 'NONCOLEXP' • 'CORSUB' • 'NONCORSUB' • 'SUBQUERY' • 'EXPRESSION' • Blanks 	S
RIGHT_HAND_PNO	INTEGER NOT NULL	If the predicate is a compound predicate (AND/OR), then this column indicates the second child predicate. However, this column is not reliable when the predicate tree consolidation happens. Use PARENT_PNO instead to reconstruct the predicate tree.	S
RHS_TABNO	SMALLINT NOT NULL	If the RHS of the predicate is a table column, then this column indicates a number which uniquely identifies the corresponding table reference within a query.	S
RHS_QBNO	SMALLINT NOT NULL	If the RHS of the predicate is a subquery, then this column indicates a number which uniquely identifies the corresponding query block within a query.	S
FILTER_FACTOR	FLOAT NOT NULL	The estimated filter factor.	S
BOOLEAN_TERM	CHAR(1) NOT NULL	Whether this predicate can be used to determine the truth value of the whole WHERE clause.	S
SEARCHARG	CHAR(1) NOT NULL	Whether this predicate can be processed by data manager (DM). If it is not, then the relational data service (RDS) needs to be used to take care of it, which is more costly.	S
JOIN	CHAR(1) NOT NULL	Whether the predicate can be used as a simple join predicate between two tables.	S
AFTER_JOIN	CHAR(1) NOT NULL	Indicates the predicate evaluation phase: <ul style="list-style-type: none"> 'A' After join 'D' During join blank Not applicable 	S

Table 344. SYSIBM.SYSQUERYPREDICATE table column descriptions (continued)

Column name	Data type	Description	Use
ADDED_PRED	CHAR(1) NOT NULL	Whether it is generated by transitive closure, which means Db2 can generate additional predicates to provide more information for access path selection, when the set of predicates that belong to a query logically imply other predicates.	S
REDUNDANT_PRED	CHAR(1) NOT NULL	Whether it is a redundant predicate, which means evaluation of other predicates in the query already determines the result that the predicate provides.	S
DIRECT_ACCESS	CHAR(1) NOT NULL	Whether the predicate is direct access, which means one can navigate directly to the row through ROWID.	S
KEYFIELD	CHAR(1) NOT NULL	Whether the predicate includes the index key column of the involved table for all applicable indexes considered by Db2.	S
EXPLAIN_TIME	TIMESTAMP NOT NULL	The time when the EXPLAIN information was captured: All cached statements When the statement entered the cache, in the form of a full-precision timestamp value. Non-cached static statements When the statement was bound, in the form of a full precision timestamp value. Non-cached dynamic statements When EXPLAIN was executed, in the form of a value equivalent to a CHAR(16) representation of the time appended by 4 zeros.	S
CATEGORY	SMALLINT NOT NULL,	IBM internal use only.	S
CATEGORY_B	SMALLINT NOT NULL	IBM internal use only.	S
TEXT	VARCHAR(2000) NOT NULL	The transformed predicate text; truncated if exceeds 2000 characters.	S
PRED_ENCODE	CHAR(1) NOT NULL WITH DEFAULT	IBM internal use only.	S
PRED_CCsid	SMALLINT NOT NULL WITH DEFAULT	IBM internal use only.	S
PRED_MCCsid	SMALLINT NOT NULL WITH DEFAULT	IBM internal use only.	S
MARKER	CHAR(1) NOT NULL WITH DEFAULT	Whether this predicate includes host variables, parameter markers, or special registers.	S
PARENT_PNO	INTEGER NOT NULL	The parent predicate number. If this predicate is a root predicate within a query block, then this column is 0.	S
NEGATION	CHAR(1) NOT NULL	Whether this predicate is negated via NOT.	S
LITERALS	VARCHAR(128) NOT NULL	This column indicates the literal value or literal values separated by colon symbols.	S

Table 344. SYSIBM.SYSQUERYPREDICATE table column descriptions (continued)

Column name	Data type	Description	Use
CLAUSE	CHAR(8) NOT NULL	The clause where the predicate exists: 'HAVING ' The HAVING clause 'ON ' The ON clause 'WHERE ' The WHERE clause SELECT The SELECT clause	S
GROUP_MEMBER	VARCHAR(24) NOT NULL	The member name of the Db2 that executed EXPLAIN. The column is blank if the Db2 subsystem was not in a data sharing environment when EXPLAIN was executed.	S
ORIGIN	CHAR(1) NOT NULL WITH DEFAULT	Indicates the origin of the predicate. Blank Generated by Db2 C Column mask R Row permission U Specified by the user	S
UNCERTAINTY	FLOAT(4) NOT NULL WITH DEFAULT	Describes the uncertainty factor of a predicate's estimated filter factor. A bigger value indicates a higher degree of uncertainty. Value zero indicates no uncertainty or uncertainty not considered.	S
SECTNOI	INTEGER NOT NULL WITH DEFAULT	The section number of the statement. The value is taken from the same column in SYSPACKSTMT or SYSSTMT tables and can be used to join tables to reconstruct the access path for the statement. This column is applicable only for static statements.	S
COLLID	VARCHAR(128) NOT NULL WITH DEFAULT	The collection ID: DSNDYNAMICSQLCACHE The row originates from the dynamic statement cache DSNEXPLAINMODEYES The row originates from an application that specifies YES for the value of the CURRENT EXPLAIN MODE special register. DSNEXPLAINMODEEXPLAIN The row originates from an application that specifies EXPLAIN for the value of the CURRENT EXPLAIN MODE special register.	S
VERSION	VARCHAR(122) NOT NULL WITH DEFAULT	The version identifier for the package. Applies only to an embedded EXPLAIN statement executed from a package or to a statement that is explained when binding a package. A blank indicates that the column is not applicable.	S

Related tasks

[Overriding predicate selectivities at the statement level \(Db2 Performance\)](#)

Related reference

[Tables for influencing access path selection \(Db2 Performance\)](#)

[DSN_PREDICAT_TABLE \(Db2 Performance\)](#)

SYSQUERYSEL catalog table

The SYSQUERYSEL table contains information about the selectivity of predicates for queries in the SYSQUERY table that have been identified for extended optimization. It correlates to the SYSQUERY table by the QUERYID column. The schema is SYSIBM.

Table 345. SYSIBM.SYSQUERYSEL table column descriptions

Column name	Data type	Description	Use
QUERYID	BIGINT NOT NULL	The identifier of the query.	S
QUERYNO	INTEGER NOT NULL	<p>A number that identifies the statement that is being explained. The origin of the value depends on the context of the row:</p> <p>For rows produced by EXPLAIN statements The number specified in the QUERYNO clause, which is an optional part of the SELECT, INSERT, UPDATE, MERGE, and DELETE statement syntax.</p> <p>For rows not produced by EXPLAIN statements Db2 assigns a number that is based on the line number of the SQL statement in the source program.</p> <p>When the values of QUERYNO are based on the statement number in the source program, values that exceed 32767 are reported as 0. However, in certain rare cases, the value is not guaranteed to be unique.</p>	S
QBLOCKNO	SMALLINT NOT NULL	A number that identifies each query block within a query. The value of the numbers are not in any particular order, nor are they necessarily consecutive.	S
APPLNAME	VARCHAR(24) NOT NULL	The name of the application plan for the row. Applies only to embedded EXPLAIN statements that are executed from a plan or to statements that are explained when binding a plan. A blank indicates that the column is not applicable.	S
PROGNAME	VARCHAR(128) NOT NULL	The name of the program or package containing the statement being explained. Applies only to embedded EXPLAIN statements and to statements explained as the result of binding a plan or package. A blank indicates that the column is not applicable.	S
SECTNOI	INTEGER NOT NULL	The section number of the statement. The value is taken from the same column in SYSPACKSTMT or SYSSTMT tables and can be used to join tables to reconstruct the access path for the statement. This column is applicable only for static statements.	S

Table 345. SYSIBM.SYSQUERYSEL table column descriptions (continued)

Column name	Data type	Description	Use
COLLID	VARCHAR(128) NOT NULL	The collection ID: DSNDYNAMICSQLCACHE The row originates from the dynamic statement cache DSNEXPLAINMODEYES The row originates from an application that specifies YES for the value of the CURRENT EXPLAIN MODE special register. DSNEXPLAINMODEEXPLAIN The row originates from an application that specifies EXPLAIN for the value of the CURRENT EXPLAIN MODE special register. When the SQL statement is embedded in a non-inline SQL function or native SQL procedure, this column is not used and is blank.	S
VERSION	VARCHAR(122) NOT NULL	The version identifier for the package. Applies only to an embedded EXPLAIN statement executed from a package or to a statement that is explained when binding a package. A blank indicates that the column is not applicable. When the SQL statement is embedded in a non-inline SQL function or native SQL procedure, this column is not used and is blank.	S
PREDNO	INTEGER NOT NULL	Identifies the predicate	S
INSTANCE	SMALLINT NOT NULL	The selectivity instance, which is used to group related selectivities.	S
SELECTIVITY	FLOAT NOT NULL	The selectivity of the predicate.	S
WEIGHT	FLOAT (4) NOT NULL	The weight of the selectivity instance. For example, a value of .25 means that 25% of the time when a query is executed the predicate will have this selectivity.	S
ASSUMPTION	VARCHAR(128) NOT NULL	Indicates how the selectivity was estimated, or will be used: One of the following values: 'NORMAL' Estimated using the normal selectivity assumptions. 'OVERRIDE' To be used as input to the Optimizer and override it's selectivity estimation.	S

Table 345. SYSIBM.SYSQUERYSEL table column descriptions (continued)

Column name	Data type	Description	Use
INSERT_TIME	TIMESTAMP NOT NULL GENERATED ALWAYS AS ROW CHANGE TIMESTAMP	The time when the row was inserted.	S
EXPLAIN_TIME	TIMESTAMP	The time when the EXPLAIN information was captured: All cached statements When the statement entered the cache, in the form of a full-precision timestamp value. Non-cached static statements When the statement was bound, in the form of a full precision timestamp value. Non-cached dynamic statements When EXPLAIN was executed, in the form of a value equivalent to a CHAR(16) representation of the time appended by 4 zeros.	S
REMARKS	VARCHAR(762)	Internal use only.	S

Related tasks

[Overriding predicate selectivities at the statement level \(Db2 Performance\)](#)

Related reference

[Tables for influencing access path selection \(Db2 Performance\)](#)

[DSN_PREDICATE_SELECTIVITY table \(Db2 Performance\)](#)

SYSQUERY_AUX catalog table

The SYSQUERY_AUX table is an auxiliary table for the STMTTEXT column of the SYSQUERY table. The schema is SYSIBM.

Table 346. SYSIBM.SYSQUERY_AUX table column descriptions

Column name	Data type	Description	Use
STMTTEXT	CLOB(2M)	The full text of the query.	G

SYSRELS catalog table

The SYSRELS table contains one row for every referential constraint. The schema is SYSIBM.

Table 347. SYSIBM.SYSRELS table column descriptions

Column name	Data type	Description	Use
CREATOR	VARCHAR(128) NOT NULL	The schema of the dependent table of the referential constraint.	G
TBNAME	VARCHAR(128) NOT NULL	Name of the dependent table of the referential constraint.	G

Table 347. SYSIBM.SYSRELS table column descriptions (continued)

Column name	Data type	Description	Use
RELNAME	VARCHAR(128) NOT NULL	Constraint name.	G
REFTBNAME	VARCHAR(128) NOT NULL	Name of the parent table of the referential constraint.	G
REFTBCREATOR	VARCHAR(128) NOT NULL	The schema of the parent table.	G
COLCOUNT	SMALLINT NOT NULL	Number of columns in the foreign key.	G
DELETERULE	CHAR(1) NOT NULL	Type of delete rule for the referential constraint: A NO ACTION C CASCADE N SET NULL R RESTRICT	G
IBMREQD	CHAR(1) NOT NULL	A value of Y indicates that the row was provided with the Db2 product code. For all other values, see Release dependency indicators . The value in this field is not a reliable indicator of release dependencies. RELCREATED should be used instead.	G
RELOBID1	SMALLINT NOT NULL WITH DEFAULT	Internal identifier of the constraint with respect to the database that contains the parent table.	S
RELOBID2	SMALLINT NOT NULL WITH DEFAULT	Internal identifier of the constraint with respect to the database that contains the dependent table.	S
TIMESTAMP	TIMESTAMP NOT NULL WITH DEFAULT	Date and time the constraint was defined. If the constraint is between catalog tables prior to Version 2 Release 3, the value is '1985-04-01-00.00.00.000000!'.	G
IXOWNER	VARCHAR(128) NOT NULL WITH DEFAULT	Schema for a unique non-primary index used to enforce the parent key of a referential constraint. Blank or empty string for a primary key used to enforce the parent key of a referential constraint which is a primary key.	G

Table 347. SYSIBM.SYSRELS table column descriptions (continued)

Column name	Data type	Description	Use
IXNAME	VARCHAR(128) NOT NULL WITH DEFAULT	Name of a unique non-primary index used to enforce the parent key of a referential constraint. Empty string for a primary index used to enforce the parent key of a referential constraint which is a primary key.	G
ENFORCED	CHAR(1) NOT NULL WITH DEFAULT 'Y'	Enforced by the system or not: Y Enforced by the system N Not enforced by the system (trusted)	G
CHECKEXISTINGDATA	CHAR(1) NOT NULL WITH DEFAULT	Option for checking existing data: I Immediately check existing data. If ENFORCED = 'Y' and this is not a temporal referential constraint, this column will have a value of 'I'. N Never check existing data. If ENFORCED = 'N', this column will have a value of 'N'. T Immediately check existing data for a temporal referential constraint.	G
RELCREATED	CHAR(1) NOT NULL	The release of Db2 that is used to create the object. See Release dependency indicators for the values.	G

SYSRESAUTH catalog table

The SYSRESAUTH table records CREATE IN and PACKADM ON privileges for collections; USAGE privileges for distinct types; USE privileges for buffer pools, storage groups, and table spaces; and REVOVKE privileges for Java archive (JAR) files. The schema is SYSIBM.

Column name	Data type	Description	Use
GRANTOR	VARCHAR(128) NOT NULL	Authorization ID of the user who granted the privilege.	G
GRANTEE	VARCHAR(128) NOT NULL	Authorization ID of the user who holds the privilege. Could also be PUBLIC for a grant to PUBLIC.	G
QUALIFIER	VARCHAR(128) NOT NULL	Qualifier of the table space (the database name) if the privilege is for a table space (OBTYP='R'). The schema name of the user-defined data type if the privilege is for a distinct type (OBTYP='D'). The schema name of the JAR file if the privilege is for a JAR file (OBTYP='J'). The value is PACKADM if the privilege is for a collection (OBTYP='C') and the authority held is PACKADM. Otherwise, the value is blank.	G

Column name	Data type	Description	Use
NAME	VARCHAR(128) NOT NULL	Name of the buffer pool, collection, Db2 storage group, G distinct type, or table space. Could also be ALL when USE OF ALL BUFFERPOOLS is granted.	G
—	CHAR(1) NOT NULL	Internal use only.	I
AUTHHOWGOT	CHAR(1) NOT NULL	Authorization level of the user from whom the privileges were received. This authorization level is not necessarily the highest authorization level of the grantor. blank Not applicable A PACKADM (on collection *) C DBCTRL D DBADM E SECADM G ACCESSCTRL L SYSCTRL M DBMAINT P PACKADM (on a specific collection) S SYSADM T DATAACCESS	G
OBTYPE	CHAR(1) NOT NULL	Type of object: B Buffer pool C Collection D Distinct type R Table space S Storage group J JAR file (Java archive file)	G

Column name	Data type	Description	Use
–	CHAR(12) NOT NULL	Internal use only.	I
DATEGRANTED	CHAR(6) NOT NULL	Not used.	N
TIMEGRANTED	CHAR(8) NOT NULL	Not used.	N
USEAUTH	CHAR(1) NOT NULL	Whether the privilege is held with the GRANT option: G Privilege is held with the GRANT option Y Privilege is held without the GRANT option The authority held is PACKADM when the OBTYPE is C (a collection) and QUALIFIER is PACKADM. The authority held is CREATE IN when the OBTYPE is C and QUALIFIER is blank.	G
IBMREQD	CHAR(1) NOT NULL	A value of Y indicates that the row was provided with the Db2 product code. For all other values, see Release dependency indicators . The value in this field is not a reliable indicator of release dependencies.	G
GRANTEDTS	TIMESTAMP NOT NULL WITH DEFAULT	Time when the GRANT statement was executed.	G
GRANTEETYPE	CHAR(1) NOT NULL WITH DEFAULT	Indicates the type of grantee: blank Authorization ID L Role R Internal use only	G
GRANTORTYPE	CHAR(1) NOT NULL WITH DEFAULT	Indicates the type of grantor: blank Authorization ID L Role	G
SYS_START	TIMESTAMP(12) NOT NULL GENERATED ALWAYS AS ROW BEGIN	Reserved for future IBM use. The row-begin column of the SYSTEM_TIME period, for system-period data versioning.	G

Column name	Data type	Description	Use
SYS_END	TIMESTAMP(12) NOT NULL GENERATED ALWAYS AS ROW END	Reserved for future IBM use.The row-end column of the SYSTEM_TIME period, for system-period data versioning.	G
TRANS_START	TIMESTAMP(12) NOT NULL GENERATED ALWAYS AS TRANSACTION START ID	Reserved for future IBM use.	G

SYSROLES catalog table

The SYSROLES table contains one row for each role. The schema is SYSIBM.

Table 348. SYSIBM.SYSROLES table column descriptions

Column name	Data type	Description	Use
NAME	VARCHAR(128) NOT NULL	The name of the role.	G
DEFINER	VARCHAR(128) NOT NULL	The authorization ID or role that defined this role listed in the NAME column.	G
DEFINERTYPE	CHAR(1) NOT NULL	The type of definer: L Role blank Authorization ID	G
CREATEDTS	TIMESTAMP NOT NULL	The time when the role is created.	G
RELCREATED	CHAR(1) NOT NULL	The release of Db2 that is used to create the role. See Release dependency indicators for the values.	G
REMARKS	VARCHAR(762) NOT NULL	A character string that is provided using the COMMENT statement.	G
IBMREQD	CHAR(1) NOT NULL	A value of Y indicates that the row was provided with the Db2 product code. For all other values, see Release dependency indicators . The value in this field is not a reliable indicator of release dependencies. RELCREATED should be used instead.	G

SYSROUTINEAUTH catalog table

The SYSROUTINEAUTH table records the privileges that are held by users on routines. (A routine can be a user-defined function, cast function, or stored procedure.) The schema is SYSIBM.

Table 349. SYSIBM.SYSROUTINEAUTH table column descriptions

Column name	Data type	Description	Use
GRANTOR	VARCHAR(128) NOT NULL	Authorization ID of the user who granted the privilege.	G
GRANTEE	VARCHAR(128) NOT NULL	Authorization ID of the user who holds the privilege or the name of a plan or package that uses the privilege. Can also be PUBLIC for a grant to PUBLIC.	G
SCHEMA	VARCHAR(128) NOT NULL	Schema of the routine	G
SPECIFICNAME	VARCHAR(128) NOT NULL	Specific name of the routine. An asterisk (*) if the privilege is held on all routines in the schema.	G
GRANTEDTS	TIMESTAMP NOT NULL	Time when the GRANT statement was executed.	G
ROUTINETYPE	CHAR(1) NOT NULL	Type of routine: F User-defined function or cast function P Stored procedure	G
GRANTEETYPE	CHAR(1) NOT NULL	Type of grantee: blank An authorization ID L Role P An application plan or package. The grantee is a package if COLLID is not blank. R Internal use only	G

Table 349. SYSIBM.SYSROUTINEAUTH table column descriptions (continued)

Column name	Data type	Description	Use
AUTHHOWGOT	CHAR(1) NOT NULL	<p>Authorization level of the user from whom the privileges were received. This authorization level is not necessarily the highest authorization level of the grantor.</p> <p>This field is also used to indicate that the privilege was held on all schemas by the grantor.</p> <p>blank Not applicable</p> <p>1 Grantor had privilege on schema.* at time of grant</p> <p>E SECADM</p> <p>G ACCESSCTRL</p> <p>L SYSCTRL</p> <p>S SYSADM</p> <p>T DATAACCESS</p>	G
EXECUTEAUTH	CHAR(1) NOT NULL	<p>Whether GRANTEE can execute the routine:</p> <p>Y Privilege is held without GRANT option.</p> <p>G Privilege is held with GRANT option.</p>	G
COLLID	VARCHAR(128) NOT NULL	<p>If the GRANTEE is a package, its collection name. Otherwise, the value is blank.</p>	G
CONTOKEN	CHAR(8) NOT NULL FOR BIT DATA	<p>If the GRANTEE is a package, the consistency token of the DBRM from which the package was derived. Otherwise, the value is blank.</p>	G
IBMREQD	CHAR(1) NOT NULL	<p>A value of Y indicates that the row was provided with the Db2 product code. For all other values, see Release dependency indicators.</p> <p>The value in this field is not a reliable indicator of release dependencies.</p>	G
GRANTORTYPE	CHAR(1) NOT NULL WITH DEFAULT	<p>Indicates the type of grantor:</p> <p>blank Authorization ID</p> <p>L Role</p>	G

Table 349. SYSIBM.SYSROUTINEAUTH table column descriptions (continued)

Column name	Data type	Description	Use
SYS_START	TIMESTAMP(12) NOT NULL GENERATED ALWAYS AS ROW BEGIN	Reserved for future IBM use.The row-begin column of the SYSTEM_TIME period, for system-period data versioning.	G
SYS_END	TIMESTAMP(12) NOT NULL GENERATED ALWAYS AS ROW END	Reserved for future IBM use.The row-end column of the SYSTEM_TIME period, for system-period data versioning.	G
TRANS_START	TIMESTAMP(12) NOT NULL GENERATED ALWAYS AS TRANSACTION START ID	Reserved for future IBM use.	G

SYSROUTINES catalog table

The SYSROUTINES table contains a row for every routine. (A routine can be a user-defined function, cast function, or stored procedure.) The schema is SYSIBM.

Table 350. SYSIBM.SYSROUTINES table column descriptions

Column name	Data type	Description	Use
SCHEMA	VARCHAR(128) NOT NULL	Schema of the routine.	G
OWNER	VARCHAR(128) NOT NULL	Owner of the routine.	G
NAME	VARCHAR(128) NOT NULL	Name of the routine.	G
ROUTINETYPE	CHAR(1) NOT NULL	Type of routine: F User-defined function or cast function P Stored procedure	G
CREATEDBY	VARCHAR(128) NOT NULL	Primary authorization ID of the user who created the routine.	G
SPECIFICNAME	VARCHAR(128) NOT NULL	Specific name of the routine.	G
ROUTINEID	INTEGER NOT NULL	Internal identifier of the routine.	S

Table 350. SYSIBM.SYSROUTINES table column descriptions (continued)

Column name	Data type	Description	Use
RETURN_TYPE	INTEGER NOT NULL	Internal identifier of the result data type of the function. The column contains a -2 if the function is a table function.	S
ORIGIN	CHAR(1) NOT NULL	Origin of the routine: E External routine or external SQL procedure N Native SQL procedure Q SQL function S System-generated function U Sourced on user-defined function or built-in function	G
FUNCTION_TYPE	CHAR(1) NOT NULL	Type of function: C Aggregate function S Scalar function T Table function blank For a stored procedure (ROUTINETYPE = 'P')	G
PARAM_COUNT	SMALLINT NOT NULL	Number of parameters for the routine.	G
LANGUAGE	VARCHAR(24) NOT NULL	Implementation language of the routine: <ul style="list-style-type: none"> • ASSEMBLE • C • COBOL • COMPJAVA • JAVA • PLI • REXX • SQL The value is blank if ROUTINETYPE = 'F' and ORIGIN is not 'E' or not 'Q'.	G
COLLID	VARCHAR(128) NOT NULL	Name of the package collection to be used when the routine is executed. A blank value indicates the package collection is the same as the package collection of the program that invoked the routine.	G

Table 350. SYSIBM.SYSROUTINES table column descriptions (continued)

Column name	Data type	Description	Use
SOURCESHEMA	VARCHAR(128) NOT NULL	If ORIGIN is 'U' and ROUTINETYPE is 'F', the schema of the source user-defined function ('SYSIBM' for a source built-in function). Otherwise, the value is blank.	G
SOURCESPECIFIC	VARCHAR(128) NOT NULL	If ORIGIN is 'U' and ROUTINETYPE is 'F', the specific name of the source user-defined function or source built-in function name. Otherwise, the value is blank.	G
DETERMINISTIC	CHAR(1) NOT NULL	The deterministic option of an external function or a stored procedure: N Indeterminate (results might differ with a given set of input values). Y Deterministic (results are consistent). blank ROUTINETYPE='F' and ORIGIN is not 'E' or not 'Q' (the routine is a function, but not an external function or an SQL function).	G
EXTERNAL_ACTION	CHAR(1) NOT NULL	The external action option of an external function or SQL function: N Function has no side effects. E Function has external side effects so that the number of invocations is important. blank ORIGIN is not 'E' or 'Q' for the function (ROUTINETYPE='F'), or it is a stored procedure (ROUTINETYPE='P').	G
NULL_CALL	CHAR(1) NOT NULL	The CALLED ON NOT NULL INPUT option of an external function or stored procedure: N The routine is not called if any parameter has a NULL value. Y The routine is called if any parameter has a NULL value. blank ROUTINETYPE='F' and ORIGIN is not 'E' (the routine is a function, but not an external function).	G

Table 350. SYSIBM.SYSROUTINES table column descriptions (continued)

Column name	Data type	Description	Use
CAST_FUNCTION	CHAR(1) NOT NULL	Whether the routine is a cast function: N The routine is not a cast function. Y The routine is a cast function. blank ORIGIN is not 'E' for the function (ROUTINETYPE='F'), or it is a stored procedure (ROUTINETYPE='P'). A cast function is generated by Db2 for a CREATE TYPE statement.	G
SCRATCHPAD	CHAR(1) NOT NULL	The SCRATCHPAD option of an external function: N This function does not have a SCRATCHPAD. Y This function has a SCRATCHPAD. blank ORIGIN is not 'E' for the function (ROUTINETYPE='F'), or it is a stored procedure (ROUTINETYPE='P').	G
SCRATCHPAD_LENGTH	INTEGER NOT NULL	Length of the scratchpad if the ORIGIN is 'E' for the function (ROUTINETYPE='F') and NO SCRATCHPAD is not specified. Otherwise, the value is 0.	G
FINAL_CALL	CHAR(1) NOT NULL	The FINAL CALL option of an external function: N A final call will not be made to the function. Y A final call will be made to the function. blank ORIGIN is not 'E' for the function (ROUTINETYPE='F'), or it is a stored procedure (ROUTINETYPE='P').	G
PARALLEL	CHAR(1) NOT NULL	The PARALLEL option of an external function: A This function can be invoked by parallel tasks. D This function cannot be invoked by parallel tasks. blank ORIGIN is not 'E' for the function (ROUTINETYPE='F'), or it is a stored procedure (ROUTINETYPE='P').	G

Table 350. SYSIBM.SYSROUTINES table column descriptions (continued)

Column name	Data type	Description	Use
PARAMETER_STYLE	CHAR(1) NOT NULL	<p>The PARAMETER STYLE option of an external function or stored procedure:</p> <p>D DB2SQL. All parameters are passed to the external function or stored procedure according to the DB2SQL standard convention.</p> <p>G GENERAL. All parameters are passed to the stored procedure according to the GENERAL standard convention.</p> <p>N GENERAL CALL WITH NULLS. All parameters are passed to the stored procedure according to the GENERAL WITH NULLS convention.</p> <p>J JAVA. All parameters are passed to the function or procedure according to the conventions for JAVA and SQLJ specifications.</p> <p>blank The column is blank if the ORIGIN is not 'E' or if LANGUAGE is SQL.</p>	G
FENCED	CHAR(1) NOT NULL	<p>Y Indicates that this routine runs separately from the Db2 address space in a WLM managed Db2 address space. All user-defined routines that are not marked with Y in this column run in the Db2 address space.</p> <p>blank ORIGIN is 'Q' or ORIGIN is 'N'.</p>	G
SQL_DATA_ACCESS	CHAR(1) NOT NULL	<p>The SQL statements that are allowed in an external function, SQL function, or stored procedure:</p> <p>C CONTAINS SQL - Only SQL that does not read or modify data is allowed.</p> <p>M MODIFIES SQL DATA - All SQL is allowed, including SQL that reads or modifies data.</p> <p>N NO SQL - SQL is not allowed.</p> <p>R READS SQL DATA - Only SQL that reads data is allowed.</p> <p>blank Not applicable.</p>	G

Table 350. SYSIBM.SYSROUTINES table column descriptions (continued)

Column name	Data type	Description	Use
DBINFO	CHAR(1) NOT NULL	<p>The DBINFO option of an external function or stored procedure:</p> <p>N No, the DBINFO parameter will not be passed to the external function or stored procedure.</p> <p>Y Yes, the DBINFO parameter will be passed to the external function or stored procedure.</p> <p>blank ORIGIN is not 'E'.</p>	G
STAYRESIDENT	CHAR(1) NOT NULL	<p>The STAYRESIDENT option of the routine, which determines whether the routine is to be deleted from memory when the routine ends.</p> <p>N The load module is to be deleted from memory after the routine terminates.</p> <p>Y The load module is to remain resident in memory after the routine terminates.</p> <p>blank ORIGIN is not 'E'.</p>	G
ASUTIME	INTEGER NOT NULL	<p>Number of CPU service units permitted for any single invocation of this routine. If ASUTIME is zero, the number of CPU service units is unlimited. The value is 0 if ROUTINETYPE = 'F' and ORIGIN is not 'E'.</p> <p>If a routine consumes more CPU service units than the ASUTIME value allows, Db2 cancels the routine.</p>	G
WLM_ENVIRONMENT	VARCHAR(96) NOT NULL	<p>Name of the WLM environment to be used to run this routine.</p> <p>When ORIGIN = 'N', this is the name of the WLM ENVIRONMENT FOR DEBUG MODE that is to be used when debugging a native SQL procedure.</p> <p>The column is blank if ROUTINETYPE = 'F' and ORIGIN is not 'E'. If the ROUTINETYPE = 'P', the value might be blank. If this value is blank the stored procedure cannot be run.</p>	G

Table 350. SYSIBM.SYSROUTINES table column descriptions (continued)

Column name	Data type	Description	Use
WLM_ENV_FOR_NESTED	CHAR(1) NOT NULL	<p>For nested routine calls, indicates whether the address space of the calling stored procedure or user-defined function is used to run the nested stored procedure or user-defined function:</p> <p>N The nested stored procedure or user-defined function runs in an address space other than the specified WLM environment if the calling stored procedure or user-defined function is not running in the specified WLM environment. 'WLM ENVIRONMENT name' was specified.</p> <p>Y The nested stored procedure or user-defined function runs in the environment used by the calling stored procedure or user-defined function. 'WLM ENVIRONMENT(name,*)' was specified.</p> <p>blank WLM_ENVIRONMENT is blank. The column is blank if ROUTINETYPE = 'F' and ORIGIN is not 'E'.</p>	G
PROGRAM_TYPE	CHAR(1) NOT NULL	<p>Indicates whether the routine runs as a Language Environment main routine or a subroutine:</p> <p>M The routine runs as a main routine.</p> <p>S The routine runs as a subroutine.</p> <p>blank ORIGIN is not 'E'.</p>	G
EXTERNAL_SECURITY	CHAR(1) NOT NULL	<p>Specifies the authorization ID to be used if the routine accesses resources protected by an external security product:</p> <p>D Db2 - The authorization ID associated with the WLM-established stored procedure address space.</p> <p>U SESSION_USER - The authorization ID of the SQL user that invoked the routine.</p> <p>C DEFINER - The authorization ID of the owner of the routine.</p> <p>blank ORIGIN is not 'E'.</p>	G

Table 350. SYSIBM.SYSROUTINES table column descriptions (continued)

Column name	Data type	Description	Use
COMMIT_ON_RETURN	CHAR(1) NOT NULL	If ROUTINETYPE = 'P', whether the transaction is always to be committed immediately on successful return (non-negative SQLCODE) from this stored procedure: N The unit of work is to continue. Y The unit of work is to be committed immediately. A The unit of work of the autonomous procedure is committed immediately, but other work of the calling application is not committed. If ROUTINETYPE = 'F', the value is blank.	G
RESULT_SETS	SMALLINT NOT NULL	If ROUTINETYPE = 'P', the maximum number of ad hoc result sets that this stored procedure can return. If no ad hoc result sets exist or ROUTINETYPE = 'F', the value is zero.	G
LOBCOLUMNS	SMALLINT NOT NULL	If ORIGIN = 'E' or 'Q', the number of LOB columns found in the parameter list for this user-defined function. If no LOB columns are found in the parameter list or ORIGIN is not 'E' or not 'Q', the value is 0.	S
CREATEDTS	TIMESTAMP NOT NULL	Time when the routine was created or re-created.	G
ALTEREDTS	TIMESTAMP NOT NULL	Time when the last ALTER statement was executed for this routine.	G
IBMREQD	CHAR(1) NOT NULL	A value of Y indicates that the row was provided with the Db2 product code. For all other values, see <u>Release dependency indicators</u> . The value in this field is not a reliable indicator of release dependencies. RELCREATED should be used instead.	G
PARM1	SMALLINT NOT NULL	Internal use only.	I
PARM2	SMALLINT NOT NULL	Internal use only.	I
PARM3	SMALLINT NOT NULL	Internal use only.	I
PARM4	SMALLINT NOT NULL	Internal use only.	I

Table 350. SYSIBM.SYSROUTINES table column descriptions (continued)

Column name	Data type	Description	Use
PARM5	SMALLINT NOT NULL	Internal use only.	I
PARM6	SMALLINT NOT NULL	Internal use only.	I
PARM7	SMALLINT NOT NULL	Internal use only.	I
PARM8	SMALLINT NOT NULL	Internal use only.	I
PARM9	SMALLINT NOT NULL	Internal use only.	I
PARM10	SMALLINT NOT NULL	Internal use only.	I
PARM11	SMALLINT NOT NULL	Internal use only.	I
PARM12	SMALLINT NOT NULL	Internal use only.	I
PARM13	SMALLINT NOT NULL	Internal use only.	I
PARM14	SMALLINT NOT NULL	Internal use only.	I
PARM15	SMALLINT NOT NULL	Internal use only.	I
PARM16	SMALLINT NOT NULL	Internal use only.	I
PARM17	SMALLINT NOT NULL	Internal use only.	I
PARM18	SMALLINT NOT NULL	Internal use only.	I
PARM19	SMALLINT NOT NULL	Internal use only.	I
PARM20	SMALLINT NOT NULL	Internal use only.	I

Table 350. SYSIBM.SYSROUTINES table column descriptions (continued)

Column name	Data type	Description	Use
PARM21	SMALLINT NOT NULL	Internal use only.	I
PARM22	SMALLINT NOT NULL	Internal use only.	I
PARM23	SMALLINT NOT NULL	Internal use only.	I
PARM24	SMALLINT NOT NULL	Internal use only.	I
PARM25	SMALLINT NOT NULL	Internal use only.	I
PARM26	SMALLINT NOT NULL	Internal use only.	I
PARM27	SMALLINT NOT NULL	Internal use only.	I
PARM28	SMALLINT NOT NULL	Internal use only.	I
PARM29	SMALLINT NOT NULL	Internal use only.	I
PARM30	SMALLINT NOT NULL	Internal use only.	I
IOS_PER_INVOC	FLOAT NOT NULL WITH DEFAULT -1	Estimated number of I/Os that required to execute the routine. The value is -1 if the estimated number is not known.	S
INSTS_PER_INVOC	FLOAT NOT NULL WITH DEFAULT -1	Estimated number of machine instructions that required to execute the routine. The value is -1 if the estimated number is not known.	S
INITIAL_IOS	FLOAT NOT NULL WITH DEFAULT -1	Estimated number of I/O's that are performed the first time or the last time the routine is invoked. The value is -1 if the estimated number is not known.	S
INITIAL_INSTS	FLOAT NOT NULL WITH DEFAULT -1	Estimated number of machine instructions that are performed the first time or the last time the routine is invoked. The value is -1 if the estimated number is not known.	S

Table 350. SYSIBM.SYSROUTINES table column descriptions (continued)

Column name	Data type	Description	Use
CARDINALITY	FLOAT NOT NULL WITH DEFAULT -1	The predicted cardinality of the routine, -1 to trigger the use of the default value (10,000).	S
RESULT_COLS	SMALLINT NOT NULL DEFAULT 1	For a table function, the number of columns in the result table. Otherwise, the value is 1.	S
EXTERNAL_NAME	VARCHAR(762) NOT NULL	The path/module/function that Db2 should load to execute the routine. The column is blank if ROUTINETYPE = 'F' and ORIGIN is not 'E'.	G
—	VARCHAR(150) NOT NULL FOR BIT DATA	Internal use only.	I
RUNOPTS	VARCHAR(762) NOT NULL	The Language Environment run time options to be used for this routine. An empty string indicates that the installation default Language Environment run time options are to be used. The column is blank if ROUTINETYPE = 'F' and ORIGIN is not 'E'.	G
REMARKS	VARCHAR(762) NOT NULL	A character string provided by the user with the COMMENT statement.	G
JAVA_SIGNATURE	VARCHAR(3072) NOT NULL WITH DEFAULT	The signature of the JAR file. blank When PARAMETER STYLE is not JAVA. The column is also blank if ROUTINETYPE = 'F' and ORIGIN is not 'E'.	G
CLASS	VARCHAR(384) NOT NULL WITH DEFAULT	The class name contained in the JAR file. blank When PARAMETER STYLE is not JAVA. The column is also blank if ROUTINETYPE = 'F' and ORIGIN is not 'E'.	G
JARSCHEMA	VARCHAR(128) NOT NULL WITH DEFAULT	The schema of the JAR file. blank When PARAMETER STYLE is not JAVA. The column is also blank if ROUTINETYPE = 'F' and ORIGIN is not 'E'.	G
JAR_ID	VARCHAR(128) NOT NULL WITH DEFAULT	The name of the JAR file. blank When PARAMETER STYLE is not JAVA. The column is also blank if ROUTINETYPE = 'F' and ORIGIN is not 'E'.	G

Table 350. SYSIBM.SYSROUTINES table column descriptions (continued)

Column name	Data type	Description	Use
SPECIAL_REGS	CHAR(1) NOT NULL WITH DEFAULT 'I'	The SPECIAL REGISTER option for a routine. I INHERIT SPECIAL REGISTERS D DEFAULT SPECIAL REGISTERS blank ROUTINETYPE = 'F' and ORIGIN is not 'E' or not 'Q'.	G
NUM_DEP_MQTS	SMALLINT NOT NULL WITH DEFAULT	Number of dependent materialized query tables. The value is 0 if the row does not describe a user-defined table function, or if no materialized query tables are defined on the table function.	G
MAX_FAILURE	SMALLINT NOT NULL WITH DEFAULT -1	Allowable failures for this routine (0-32767). If zero is specified, the routine will never be stopped. If no value is specified for this routine, the default will be -1 to indicate that the Db2 installation parameter (STORMXAB) will be used.	G
PARAMETER_CCSID	INTEGER NOT NULL WITH DEFAULT	A CCSID that specifies how character, graphic, date, time, and timestamp data types for system generated parameters to the routine such as message tokens and DBINFO should be passed. The value is dependent on the encoding scheme specified implicitly or explicitly for the PARAMETER CCSID clause defined at the system for that encoding scheme. The following list describes the CCSID for each encoding scheme: ASCII If mixed data is allowed, this CCSID is for mixed ASCII data, SBCS data uses the corresponding SBCS CCSID, and graphic data uses the corresponding DBCS CCSID. Otherwise, this CCSID is for SBCS ASCII data. EBCDIC If mixed data is allowed, this CCSID is for mixed EBCDIC data, SBCS data uses the corresponding SBCS CCSID, and graphic data uses the corresponding DBCS CCSID. Otherwise, this is the CCSID for SBCS EBCDIC data. Unicode This CCSID is for mixed data (1208). A value of zero means that the CCSIDs used are those CCSIDs for the encoding scheme of other string or datetime parameters in the parameter list or RETURNS clause CCSID clauses, or the value in the DEF ENCODING SCHEME on installation panel DSNTIPF.	G

Table 350. SYSIBM.SYSROUTINES table column descriptions (continued)

Column name	Data type	Description	Use
VERSION	VARCHAR(122) NOT NULL WITH DEFAULT	The version identifier for a native SQL procedure (indicated by the value 'N' in the column ORIGIN) or a non-inline SQL scalar function (indicated by the value 'Q' in the column ORIGIN and 'N' in the column INLINE). A zero length string for the rows that are created prior to Version 9 and for the rows that correspond to neither native SQL procedures or non-inline SQL scalar functions.	G
CONTOKEN	CHAR(8) NOT NULL WITH DEFAULT FOR BIT DATA	The consistency token for the routine. The column is set to X'20' if the value of ORIGIN is not 'N'	G
ACTIVE	CHAR(1) NOT NULL WITH DEFAULT	Identifies the active version of the routine: Y This version is active. N This version is not active. blank The value of ORIGIN is not 'N' or the row was created prior to Version 9.	G
DEBUG_MODE	CHAR(1) NOT NULL WITH DEFAULT	Identifies whether or not this routine is enabled for debugging: 1 This routine is enabled for debugging and can be debugged in a client debug session using the Db2 Unified Debugger. 0 This routine is not enabled for debugging. N This routine can never be enabled for debugging. blank The LANGUAGE is not specified as JAVA, the value of ORIGIN is not 'N', or the row was created prior to Version 9.	G
TEXT_ENVID	INTEGER NOT NULL WITH DEFAULT	Internal identifier of the environment. The column value is 0 if the value of ORIGIN is not 'N' or 'Q', or if the row was created prior to Version 9.	G
TEXT_ROWID	ROWID NOT NULL GENERATED ALWAYS	ID to support LOB columns for source text.	G

Table 350. SYSIBM.SYSROUTINES table column descriptions (continued)

Column name	Data type	Description	Use
TEXT	CLOB(2M) NOT NULL WITH DEFAULT	The text of the statement that created the SQL routine, including the body of the routine. In some cases, this column might instead contain the text of a statement that altered the SQL routine. In many cases, changes to routines or to objects on which routines are dependent do not update this value. The value is a zero-length string if the value of ORIGIN is not 'N' or if the row was created prior to Version 9.	G
OWNERTYPE	CHAR(1) NOT NULL WITH DEFAULT	Indicates the type of owner: blank Authorization ID L Role	G
PARAMETER_ VARCHARFORM	INTEGER NOT NULL WITH DEFAULT	A non-zero value that indicates the actual representation, to a LANGUAGE C routine, of any varying length string parameter that appears in the parameter list or RETURNS clause for that routine.	G
RELCREATED	CHAR(1) NOT NULL	The release of Db2 that is used to create the object. Blank if created prior to Version 9. See Release dependency indicators for all other values.	G
PACKAGEPATH	VARCHAR(4096)	The value of the PACKAGE PATH option of the CREATE FUNCTION, CREATE PROCEDURE, ALTER FUNCTION, or ALTER PROCEDURE statement that created or last changed the routine. PACKAGE PATH identifies the package path to use when the routine is executed. A blank value indicates the package path is the same as the package path of the program that invoked the routine.	G
SECURE	CHAR(1) NOT NULL WITH DEFAULT 'N'	Indicates if the routine is secured: N The routine is not secured Y The routine is secured	G
INLINE	CHAR(1) NOT NULL WITH DEFAULT	Specifies if the SQL function is inline: Y The SQL function is inline when referenced. No package is associated with this type of routine. N The SQL function has an associated package. blank Not an SQL function (the ORIGIN column has a value other than 'Q')	G

Table 350. SYSIBM.SYSROUTINES table column descriptions (continued)

Column name	Data type	Description	Use
—	BLOB(1G) NOT NULL WITH DEFAULT	Internal use only.	I
SYSTEM_DEFINED	CHAR(1) NOT NULL WITH DEFAULT	Identifies whether this routine is system defined: blank This routine is not system defined S This routine is system defined	G
WRAPPED	CHAR(1)	'Y' The routine text is obfuscated. Obfuscating source code of SQL procedures, SQL functions, and triggers (Db2 Administration Guide) . blank The routine text is not obfuscated.	G
REGENERATEDTS	TIMESTAMP(12) NOT NULL	The time when the object was regenerated. The value is valid only for objects that can be regenerated. If no regeneration has occurred, this column contains the same value as the CREATEDTS column.	G

SYSROUTINESTEXT catalog table

The SYSROUTINESTEXT is an auxiliary table for the TEXT column of SYSIBM.SYSROUTINES and is required to hold the LOB data. The schema is SYSIBM.

Table 351. SYSIBM.SYSROUTINESTEXT table column descriptions

Column name	Data type	Description	Use
TEXT	CLOB(2M) NOT NULL WITH DEFAULT	See the description of the TEXT column in “SYSROUTINES catalog table” on page 2621 .	G

SYSROUTINES_OPTS catalog table (deprecated)

The SYSROUTINES_OPTS table Contains a row for each generated routine, such as one created by Db2 for z/OS Procedure Processor DSNTPSMP, that records the build options for the routine. The schema is SYSIBM.

Deprecated function: External SQL procedures are deprecated and not as fully supported as native SQL procedures. For best results, create native SQL procedures instead. For more information, see [Creating native SQL procedures \(Db2 Application programming and SQL\)](#) and [Migrating an external SQL procedure to a native SQL procedure \(Db2 Application programming and SQL\)](#).

Rows in this table can be inserted, updated, and deleted.

Table 352. SYSIBM.SYSROUTINES_OPTS table column descriptions

Column name	Data type	Description	Use
SCHEMA	VARCHAR(128) NOT NULL	Schema of the routine.	G
ROUTINENAME	VARCHAR(128) NOT NULL	Name of the routine.	G
BUILDDATE	DATE NOT NULL WITH DEFAULT	Date the routine was built.	G
BUILDTIME	TIME NOT NULL WITH DEFAULT	Time the routine was built.	G
BUILDSTATUS	CHAR(1) NOT NULL WITH DEFAULT 'C'	Whether this version of the routine's options is the current version.	G
BUILDSHEMA	VARCHAR(128) NOT NULL	Schema name for BUILDNAME.	G
BUILDNAME	VARCHAR(128) NOT NULL	Procedure used to create the routine.	G
BUILDOWNER	VARCHAR(128) NOT NULL	Authorization ID used to create the routine.	G
IBMREQD	CHAR(1) NOT NULL WITH DEFAULT 'N'	A value of Y indicates that the row was provided with the Db2 product code. For all other values, see Release dependency indicators . The value in this field is not a reliable indicator of release dependencies.	G
PRECOMPILE_OPTS	VARCHAR(765) NOT NULL WITH DEFAULT	SQL processing (precompiler or coprocessor) options used to build the routine.	G
COMPILE_OPTS	VARCHAR(765) NOT NULL WITH DEFAULT	Compiler options used to build the routine.	G
PRELINK_OPTS	VARCHAR(765) NOT NULL WITH DEFAULT	Prelink-edit options used to build the routine.	G
LINK_OPTS	VARCHAR(765) NOT NULL WITH DEFAULT	Link-edit options used to build the routine.	G

Table 352. SYSIBM.SYSROUTINES_OPTS table column descriptions (continued)

Column name	Data type	Description	Use
BIND_OPTS	VARCHAR(3072) NOT NULL WITH DEFAULT	Bind options used to build the routine.	G
SOURCEDSN	VARCHAR(765) NOT NULL WITH DEFAULT	Name of the source data set.	G
DEBUG_MODE	CHAR(1) NOT NULL	Debugging is on or off for this object. 0 Debugging is off. Default and value on migration are both 0. 1 Debugging is on.	G

SYSROUTINES_TREE catalog table

The SYSROUTINES_TREE table is an auxiliary table for the PTREE column of the SYSROUTINES table. The schema is SYSIBM.

Table 353. SYSIBM.SYSROUTINES_TREE table column descriptions

Column name	Data type	Description	Use
PTREE	BLOB(1G) NOT NULL WITH DEFAULT	Internal use only.	I

SYSROUTINES_SRC catalog table (deprecated)

The SYSROUTINES_SRC table contains source for generated routines, such as those created by Db2 for z/OS Procedure Processor DSNTPSMP. The schema is SYSIBM.

Deprecated function: External SQL procedures are deprecated and not as fully supported as native SQL procedures. For best results, create native SQL procedures instead. For more information, see [Creating native SQL procedures \(Db2 Application programming and SQL\)](#) and [Migrating an external SQL procedure to a native SQL procedure \(Db2 Application programming and SQL\)](#).

Rows in this table can be inserted, updated, and deleted.

Table 354. SYSIBM.SYSROUTINES_SRC table column descriptions

Column name	Data type	Description	Use
SCHEMA	VARCHAR(128) NOT NULL	Schema of the routine.	G
ROUTINENAME	VARCHAR(128) NOT NULL	Name of the routine.	G

Table 354. SYSIBM.SYSROUTINES_SRC table column descriptions (continued)

Column name	Data type	Description	Use
BUILDDATE	DATE NOT NULL WITH DEFAULT	Date the routine was built.	G
BUILDTIME	TIME NOT NULL WITH DEFAULT	Time the routine was built.	G
BUILDSTATUS	CHAR(1) NOT NULL WITH DEFAULT 'C'	Whether this version of the routine's source is the current version.	G
SEQNO	INTEGER NOT NULL	Number of the source statement piece in CREATESTMT.	G
IBMREQD	CHAR(1) NOT NULL WITH DEFAULT 'N'	A value of Y indicates that the row was provided with the Db2 product code. For all other values, see Release dependency indicators . The value in this field is not a reliable indicator of release dependencies.	G
CREATESTMT	VARCHAR(7500) NOT NULL	Routine source statement.	G

SYSSCHEMAAUTH catalog table

The SYSSCHEMAAUTH table contains one or more rows for each user that is granted a privilege on a particular schema in the database. The schema is SYSIBM.

Table 355. SYSIBM.SYSSCHEMAAUTH table column descriptions

Column name	Data type	Description	Use
GRANTOR	VARCHAR(128) NOT NULL	Authorization ID of the user who granted the privileges or SYSADM.	G
GRANTEE	VARCHAR(128) NOT NULL	Authorization ID of the user or group who holds the privileges. Can also be PUBLIC for a grant to PUBLIC.	G
SCHEMANAME	VARCHAR(128) NOT NULL	Name of the schema or '*' for all schemas.	G

Table 355. SYSIBM.SYSSCHEMAAUTH table column descriptions (continued)

Column name	Data type	Description	Use
AUTHHOWGOT	CHAR(1) NOT NULL	<p>Authorization level of the user from whom the privileges were received. This authorization level is not necessarily the highest authorization level of the grantor.</p> <p>This field is also used to indicate that the privilege was held on all schemas by the grantor.</p> <p>1 Grantor had privilege on all schemas at time of grant</p> <p>E SECADM</p> <p>G ACCESSCTRL</p> <p>L SYSCTRL</p> <p>S SYSADM</p>	G
CREATEINAUTH	CHAR(1) NOT NULL	<p>Indicates whether grantee holds CREATEIN privilege on the schema:</p> <p>blank Privilege is not held</p> <p>G Privilege is held with the GRANT option</p> <p>Y Privilege is held without the GRANT option</p>	G
ALTERINAUTH	CHAR(1) NOT NULL	<p>Indicates whether grantee holds ALTERIN privilege on the schema:</p> <p>blank Privilege is not held</p> <p>G Privilege is held with the GRANT option</p> <p>Y Privilege is held without the GRANT option</p>	G
DROPINAUTH	CHAR(1) NOT NULL	<p>Indicates whether grantee holds DROPIN privilege on the schema:</p> <p>blank Privilege is not held</p> <p>G Privilege is held with the GRANT option</p> <p>Y Privilege is held without the GRANT option</p>	G
GRANTEDTS	TIMESTAMP NOT NULL	Time when the GRANT statement was executed.	G

Table 355. SYSIBM.SYSSCHEMAAUTH table column descriptions (continued)

Column name	Data type	Description	Use
IBMREQD	CHAR(1) NOT NULL	A value of Y indicates that the row was provided with the Db2 product code. For all other values, see Release dependency indicators . The value in this field is not a reliable indicator of release dependencies.	G
GRANTEETYPE	CHAR(1) NOT NULL WITH DEFAULT	Indicates the type of grantee: blank Authorization ID L Role	G
GRANTORTYPE	CHAR(1) NOT NULL WITH DEFAULT	Indicates the type of grantor: blank Authorization ID L Role	G
SYS_START	TIMESTAMP(12) NOT NULL GENERATED ALWAYS AS ROW BEGIN	Reserved for future IBM use.The row-begin column of the SYSTEM_TIME period, for system-period data versioning.	G
SYS_END	TIMESTAMP(12) NOT NULL GENERATED ALWAYS AS ROW END	Reserved for future IBM use.The row-end column of the SYSTEM_TIME period, for system-period data versioning.	G
TRANS_START	TIMESTAMP(12) NOT NULL GENERATED ALWAYS AS TRANSACTION START ID	Reserved for future IBM use.	G

SYSSEQUENCEAUTH catalog table

The SYSSEQUENCEAUTH table records the privileges that are held by users over sequences. The schema is SYSIBM.

Table 356. SYSIBM.SYSSEQUENCEAUTH table column descriptions

Column name	Data type	Description	Use
GRANTOR	VARCHAR(128) NOT NULL	Authorization ID of the user who granted the privileges.	G
GRANTEE	VARCHAR(128) NOT NULL	Authorization ID of the user or group that holds the privileges or the name of an application plan or package that uses the privileges. PUBLIC for a grant to PUBLIC.	G

Table 356. SYSIBM.SYSSEQUENCEAUTH table column descriptions (continued)

Column name	Data type	Description	Use
SCHEMA	VARCHAR(128) NOT NULL	Schema of the sequence.	G
NAME	VARCHAR(128) NOT NULL	Name of the sequence.	G
GRANTEETYPE	CHAR(1) NOT NULL	Type of grantee: blank An authorization ID. L Role P An application plan or package. The grantee is a package if COLLID is not blank. R Internal use only.	G
AUTHHOWGOT	CHAR(1) NOT NULL	Authorization level of the user from whom the privileges were received. This authorization level is not necessarily the highest authorization level of the grantor: blank Not applicable E SECADM G ACCESSCTRL L SYSCTRL S SYSADM T DATAACCESS	G
ALTERAUTH	CHAR(1) NOT NULL	Indicates whether grantee holds ALTER privilege on the sequence: blank Privilege is not held. G Privilege is held with the GRANT option. Y Privilege is held without the GRANT option.	G

Table 356. SYSIBM.SYSSEQUENCEAUTH table column descriptions (continued)

Column name	Data type	Description	Use
USEAUTH	CHAR(1) NOT NULL	Indicates whether grantee holds USAGE privilege on the sequence: blank Privilege is not held. G Privilege is held with the GRANT option. Y Privilege is held without the GRANT option.	G
COLLID	VARCHAR(128) NOT NULL	If the GRANTEE is a package, its collection name. Otherwise, a string of length zero.	G
CONTOKEN	CHAR(8) NOT NULL FOR BIT DATA	If the GRANTEE is a package, the consistency token of the DBRM from which the package was derived. Otherwise, blank.	G
GRANTEDTS	TIMESTAMP NOT NULL	Time when the GRANT statement was executed.	G
IBMREQD	CHAR(1) NOT NULL	A value of Y indicates that the row was provided with the Db2 product code. For all other values, see Release dependency indicators . The value in this field is not a reliable indicator of release dependencies.	G
GRANTORTYPE	CHAR(1) NOT NULL WITH DEFAULT	Indicates the type of grantor: blank Authorization ID L Role	G
SYS_START	TIMESTAMP(12) NOT NULL GENERATED ALWAYS AS ROW BEGIN	Reserved for future IBM use.The row-begin column of the SYSTEM_TIME period, for system-period data versioning.	G
SYS_END	TIMESTAMP(12) NOT NULL GENERATED ALWAYS AS ROW END	Reserved for future IBM use.The row-end column of the SYSTEM_TIME period, for system-period data versioning.	G
TRANS_START	TIMESTAMP(12) NOT NULL GENERATED ALWAYS AS TRANSACTION START ID	Reserved for future IBM use.	G

SYSSEQUENCES catalog table

The SYSSEQUENCES table contains one row for each identity column or user-defined sequence. The schema is SYSIBM.

Table 357. SYSIBM.SYSSEQUENCES table column descriptions

Column name	Data type	Description	Use
SCHEMA	VARCHAR(128) NOT NULL	Schema of the alias or sequence. For an identity column, the value of TBCREATOR from the SYSCOLUMNS entry for the column.	G
OWNER	VARCHAR(128) NOT NULL	Owner of the alias or sequence. For an identity column, the value of TBCREATOR from the SYSCOLUMNS entry for the column.	G
NAME	VARCHAR(128) NOT NULL	Name of the alias, identity column, or sequence. The name for an identity column is generated by Db2.	G
SEQTYPE	CHAR(1) NOT NULL	Type of sequence object: A Alias for a sequence I An identity column S A user-defined sequence X An implicitly created DOCID column for a base table that contains XML data.	G
SEQUENCEID	INTEGER NOT NULL	Internal identifier of the alias, identity column, or sequence.	G
CREATEDBY	VARCHAR(128) NOT NULL	Primary authorization ID of the user who created the alias, identity column, or sequence.	G
INCREMENT	DECIMAL(31,0) NOT NULL	Increment value (positive or negative, within INTEGER scope). The value is 0 if the row describes an alias.	G
START	DECIMAL(31,0) NOT NULL	Start value. The value is 0 if the row describes an alias.	G
MAXVALUE	DECIMAL(31,0) NOT NULL	Maximum value allowed for the identity column or sequence. The value is 0 if the row describes an alias.	G
MINVALUE	DECIMAL(31,0) NOT NULL	Minimum value allowed for the identity column or sequence. The value is 0 if the row describes an alias.	G

Table 357. SYSIBM.SYSSEQUENCES table column descriptions (continued)

Column name	Data type	Description	Use
CYCLE	CHAR(1) NOT NULL	Whether cycling will occur when a boundary is reached: N No Y Yes, cycling will occur blank The row describes an alias	G
CACHE	INTEGER NOT NULL	Number of sequence values to preallocate in memory for faster access. A value of 0 indicates that values are not to be preallocated. The value is 0 if the row describes an alias.	G
ORDER	CHAR(1) NOT NULL	Whether the values must be generated in order: Y Yes N No R The values must be generated in pseudo-random order for an XML document ID column that was created when subsystem parameter XML_RANDOMIZE_DOCID was set to YES. blank The row describes an alias	G
DATATYPEID	INTEGER NOT NULL	For a built-in data type, the internal ID of the built-in type. For a distinct type, the internal ID of the distinct type. The value is 0 if the row describes an alias.	S
SOURCETYPEID	INTEGER NOT NULL	For a built-in data type, 0. For a distinct type, the internal ID of the built-in data type upon which the distinct type is based. The value is 0 if the row describes an alias.	S
CREATEDTS	TIMESTAMP NOT NULL	Timestamp of the creation of the alias, identity column, or sequence.	G
ALTEREDTS	TIMESTAMP NOT NULL	Timestamp when the last ALTER statement was executed for this alias, identity column, or sequence.	G

Table 357. SYSIBM.SYSSEQUENCES table column descriptions (continued)

Column name	Data type	Description	Use
MAXASSIGNEDVAL	DECIMAL(31,0)	<p>Last possible assigned value. MAXASSIGNEDVAL is updated each time that the next chunk of <i>n</i> values is cached. <i>n</i> is the CACHE column value. MAXASSIGNEDVAL is initialized to null when the object is created or when it is altered to restart the sequence. The value is also null when the object is an alias.</p> <p>The LOAD utility updates MAXASSIGNEDVAL for identity columns in the following ways:</p> <ul style="list-style-type: none"> • For sequence or identity column values that are generated by the Db2 database manager, LOAD updates MAXASSIGNEDVAL each time that the next chunk of <i>n</i> values is cached. <i>n</i> is the CACHE column value. • For identity column values that are generated by the user, LOAD updates MAXASSIGNEDVAL with the MAXVALUE column value or MINVALUE column value. MAXVALUE is used if the INCREMENT column value is positive. MINVALUE is used if the INCREMENT column value is negative. • LOAD with REPLACE sets MAXASSIGNEDVAL to null before loading any data. • LOAD with FORMAT INTERNAL does not update MAXASSIGNEDVAL if the data that is being loaded is in basic row format. <p>The value is 0 if the row describes an alias.</p>	G
IBMREQD	CHAR(1) NOT NULL	<p>A value of Y indicates that the row was provided with the Db2 product code. For all other values, see Release dependency indicators.</p> <p>The value in this field is not a reliable indicator of release dependencies. RELCREATED should be used instead.</p>	G
REMARKS	VARCHAR(762) NOT NULL	Character string provided by user with the COMMENT statement. The value is blank for an identity column.	G
PRECISION	SMALLINT NOT NULL WITH DEFAULT	<p>The precision defined for a sequence with a decimal or numeric type. The value is 5 for SMALLINT, 10 for INTEGER, 19 for BIGINT, or the actual precision specified by the user for the decimal data type. The value is 0 for rows created prior to Version 8.</p> <p>The value is 0 if the row describes an alias.</p>	G
RESTARTWITH	DECIMAL(31,0) NULLABLE WITH DEFAULT	<p>The sequence RESTART value for an ALTER SEQUENCE statement.</p> <p>The value is NULL for the following:</p> <ul style="list-style-type: none"> • There have been no ALTER statements with the RESTART option. • The row describes an alias 	G

Table 357. SYSIBM.SYSSEQUENCES table column descriptions (continued)

Column name	Data type	Description	Use
OWNERTYPE	CHAR(1) NOT NULL WITH DEFAULT	Indicates the type of owner: blank Authorization ID L Role	G
RELCREATED	CHAR(1) NOT NULL	The release of Db2 that is used to create the object. Blank if created prior to Version 9. See Release dependency indicators for all other values.	G
SEQSCHEMA	VARCHAR(128) NOT NULL WITH DEFAULT	For a sequence alias, identifies the schema of the sequence for which the alias is defined. Otherwise, the value is blank.	G
SEQNAME	VARCHAR(128) NOT NULL WITH DEFAULT	For a sequence alias, identifies the name of the sequence for which the alias is defined. Otherwise, the value is blank.	G

SYSSEQUENCESDEP catalog table

The SYSSEQUENCESDEP table records the dependencies of identity columns and sequences. The schema is SYSIBM.

Table 358. SYSIBM.SYSSEQUENCEDEP table column descriptions

Column name	Data type	Description	Use
BSEQUENCEID	INTEGER NOT NULL	Internal identifier of the identity column or sequence.	G
DCREATOR	VARCHAR(128) NOT NULL	The owner of the object that is dependent on this identity column or sequence.	G
IBMREQD	CHAR(1) NOT NULL	A value of Y indicates that the row was provided with the Db2 product code. For all other values, see Release dependency indicators . The value in this field is not a reliable indicator of release dependencies.	G
DNAME	VARCHAR(128) NOT NULL	Name of the object that is dependent on this identity column or sequence.	G
DCOLNAME	VARCHAR(128) NOT NULL	Name of the identity column. Blank for SQL function rows.	G

Table 358. SYSIBM.SYSSEQUENCEDEP table column descriptions (continued)

Column name	Data type	Description	Use
DTYPE	CHAR(1) NOT NULL WITH DEFAULT 'I'	The type of object that is dependent on this sequence: F SQL function I Identity column X Implicit DOCID column that is created on a base table with XML blank Represents an identity column created prior to Version 8	G
BSCHEMA	VARCHAR(128) NOT NULL WITH DEFAULT	The schema name of the sequence, will be a string of length zero for an object created prior to Version 8.	G
BNAME	VARCHAR(128) NOT NULL WITH DEFAULT	The sequence name (generated by Db2 for an identity column), will be a string of length zero for an object created prior to Version 8.	G
DSHEMA	VARCHAR(128) NOT NULL WITH DEFAULT	The qualifier of the object that is dependent on this sequence, will be a string of length zero for an object created prior to Version 8.	G
DOWNER	VARCHAR(128) NOT NULL WITH DEFAULT	The owner of the object that is dependent on this sequence. This will be a string of length zero for an object that was created prior to Version 9.	G
DOWNERTYPE	CHAR(1) NOT NULL WITH DEFAULT	The type of owner: Blank An authorization ID L A role	G

SYSSESSION catalog table

The SYSSESSION table stores the session token that generated by the server and associated session data. The schema is SYSIBM.

Column name	Data type	Description	Use
TOKEN	CHAR(40) FOR BIT DATA NOT NULL	Session token for the session.	
CORRTKN	VARCHAR(256) FOR BIT DATA	Extended client correlation token in use.	
GV_FLAGS	CHAR(2) FOR BIT DATA	Flags for internal classification of global variables (such as whether it contains arrays or LOBs.)	

Column name	Data type	Description	Use
TOTAL	CHAR(4) FOR BIT DATA NOT NULL	The number of entries in the SYSIBM.SYSSESSION_EX table that correspond to the session token.	
SPECIAL_REGISTERS	VARCHAR(16000) FOR BIT DATA NOT NULL	Special register values (as chained SQLSTTs).	
GLOBAL_VARIABLES	BLOB(2G)	global variable values(as GLBVRB). Arrays/lobs are stores as locator values that reference a row in the SYSIBM.SYSSESSION_EX table.	
ROWID	ROWID NOT NULL GENERATED ALWAYS	Generated ROWID.	

SYSSESSION_EX catalog table

The SYSSESSION_EX table contains global variable data of LOB or array type that corresponds to the locator stored in the GLOBAL_VARIABLES column of the SYSSESSION table. The schema is SYSIBM.

Column name	Data type	Description	Use
TOKEN	CHAR(40) FOR BIT DATA NOT NULL	Session token representing the session.	
LOCATOR	CHAR(8) FOR BIT DATA NOT NULL	Locator value corresponding to one of the global variables with DATATYPE as array of lobes.	
HEADER	CHAR(89) FOR BIT DATA NOT NULL	Array static descriptor header when locator value corresponds to array type.	
GVID	CHAR(8) FOR BIT DATA NOT NULL	Global variable identifier.	
DATATYPE	CHAR(2) FOR BIT DATA NOT NULL	Data type of the global variable.	
CCSID	CHAR(2) FOR BIT DATA NOT NULL	CCSID of the global variable.	
GVSHEMA	VARCHAR(130) FOR BIT DATA	Schema name of the global variable.	
GVNAME	VARCHAR(130) FOR BIT DATA	Name of the global variable.	
DATA	BLOB(2G)	Data value stored in the global variable.	

SYSSESSION_STATUS catalog table

The SYSSESSION_STATUS table contains session token and timestamp values for when the corresponding session data was last referenced. The schema is SYSIBM.

Column name	Data type	Description	Use
TOKEN	CHAR(40) FOR BIT DATA NOT NULL	Session token representing the session.	
TOKEN_TS	CHAR(16) FOR BIT DATA NOT NULL	Timestamp value when row was last referenced.	

Column name	Data type	Description	Use
TOKEN_MEMBER	CHAR(16) FOR BIT DATA	Member where row was last accessed.	
STATUS	CHAR(2) FOR BIT DATA	Status of session corresponding to the token (such as timed-out/clean disconnect).	

SYSSTATFEEDBACK catalog table

The SYSSTATFEEDBACK table contains information about missing or conflicting catalog statistics for SQL statements. The schema is SYSIBM.

The following values control the collection of statistics feedback data in the SYSSTATFEEDBACK catalog table:

- The STATFDBK_SCOPE subsystem parameter controls whether the data is collected, and whether it is collected only for static SQL statements, only for dynamic SQL statements, or for both.
- The STATSINT subsystem parameter controls when and how frequently the data is externalized.
- The STATS_FEEDBACK column of the SYSTABLES catalog table controls whether the data is collected for a particular table.

The RUNSTATS utility removes data from the SYSSTATFEEDBACK catalog table when the recommended statistics are collected.

Tip: The SYSSTATFEEDBACK table might contain rows that recommend collection of statistics for DEFINE NO objects, or empty table space partitions. However, statistics cannot be collected for such objects until after data is inserted and the underlying data sets are created. For more information, see [Effect of utilities on objects that have the DEFINE NO attribute \(Db2 Utilities\)](#).

Table 359. SYSIBM.SYSSTATFEEDBACK table column descriptions

Column name	Data type	Description	Use
TBCREATOR	VARCHAR(128)	The creator of the table.	S
TBNAME	VARCHAR(128)	The name of the table.	S
IXCREATOR	VARCHAR(128)	The creator of the index.	S
IXNAME	VARCHAR(128)	The name of the index.	S
COLNAME	VARCHAR(128)	The name of the column.	S
NUMCOLUMNS	SMALLINT	The number of columns in the column group.	S
COLGROUPCOLNO	VARCHAR(254) FOR BIT DATA	A hex representation that identifies the set of columns associated with the statistics. If the statistics are only associated with a single column, the field contains a zero length. Otherwise, the field is an array of SMALLINT column numbers with a dimension equal to the value in NUMCOLUMNS.	S

Table 359. SYSIBM.SYSSTATFEEDBACK table column descriptions (continued)

Column name	Data type	Description	Use
TYPE	CHAR(1)	The type of statistic to collect: 'C' Cardinality. 'F' Frequency. 'H' Histogram. 'I' Index. 'T' Table.	I
DBNAME	VARCHAR(24)	The name of the database.	S
TSNAME	VARCHAR(24)	The name of the table space.	S
REASON	CHAR(8)	The reason for the statistics collection recommendation: 'BASIC' A basic statistical value for a column table or index is missing. 'CONFLICT' Another statistic conflicts with this statistic. 'COMPFFIX' Multi-column cardinality statistics are needed for an index compound filter factor. 'DEFAULT' A predicate references a value that is probably a default value. 'KEYCARD' The cardinalities of index key columns are missing. 'LOWCARD' The cardinality of the column is a low value, which indicates that data skew is likely. 'NULLABLE' Distribution statistics are not available for a nullable column. 'RNGPRED' Histogram statistics are not available for a range predicate. 'PARALLEL' Parallelism could be improved by uniform partitioning of key ranges. 'STALE' A statistic appears likely to be out of sync with other statistics, based on comparison of the time that it was collected to statistics collection times for related objects.	S

Table 359. SYSIBM.SYSSTATFEEDBACK table column descriptions (continued)

Column name	Data type	Description	Use
BLOCK_RUNSTATS	CHAR(1)	Whether the row is used when optimization tools collect statistics based on the recommendations. Db2 inserts a blank value in this column for all new rows. Db2 does not refer to or change the value of this column. This is an updatable column.	S
REMARKS	VARCHAR(254)	Free form text for extensibility.	S
LASTDATE	DATE	The last date that this statistics recommendation was updated by Db2.	S

Related tasks

[Applying statistics recommendations to statistics profiles automatically \(Db2 Performance\)](#)

[Controlling the collection of statistics feedback \(Db2 Performance\)](#)

[Maintaining Db2 database statistics \(Db2 Performance\)](#)

Related reference

[DSN_STAT_FEEDBACK \(Db2 Performance\)](#)

[Statistics used for access path selection \(Db2 Performance\)](#)

[STATISTICS FEEDBACK field \(STATFDBK_SCOPE subsystem parameter\) \(Db2 Installation and Migration\)](#)

[REAL TIME STATS field \(STATSINT subsystem parameter\) \(Db2 Installation and Migration\)](#)

[SYSTABLES catalog table](#)

The SYSTABLES table contains one row for each table, view, or alias. The schema is SYSIBM. Each SYSTABLES table row indicates whether the object that it describes is a table, view, or alias, its name, who created it, the database that it belongs to, the table space it belongs to, and other information. The SYSTABLES table also has a REMARKS column in which you can store your own information about the table in question.

[RUNSTATS \(Db2 Utilities\)](#)

SYSSTMT catalog table

The SYSSTMT table contains one or more rows for each SQL statement of each DBRM. The schema is SYSIBM.

Table 360. SYSIBM.SYSSTMT table column descriptions

Column name	Data type	Description	Use
NAME	VARCHAR(24) NOT NULL	Name of the DBRM.	G
PLNAME	VARCHAR(24) NOT NULL	Name of the application plan.	G
PLCREATOR	VARCHAR(128) NOT NULL	Authorization ID of the owner of the application plan.	G
SEQNO	INTEGER NOT NULL	Sequence number of this row with respect to a statement of the plan. Rows in which the values of SEQNO, STMTNO, and SECTNO are zero are for internal use. The numbering starts with zero.	G

Table 360. SYSIBM.SYSSTMT table column descriptions (continued)

Column name	Data type	Description	Use
STMTNO	SMALLINT NOT NULL	The statement number of the statement in the source program. A statement number greater than 32767 is stored as zero. If the value is zero, see STMTNOI for the statement number. Rows in which the values of SEQNO, STMTNO, and SECTNO are zero are for internal use.	G
SECTNO	SMALLINT NOT NULL	The section number of the statement. Rows in which the values of SEQNO, STMTNO, and SECTNO are zero are for internal use.	G
IBMREQD	CHAR(1) NOT NULL	A value of Y indicates that the row was provided with the Db2 product code. For all other values, see Release dependency indicators . The value in this field is not a reliable indicator of release dependencies.	G
TEXT	VARCHAR(3800) NOT NULL FOR BIT DATA	Text or portion of the text of the SQL statement.	S
ISOLATION	CHAR(1) NOT NULL WITH DEFAULT	Isolation level for the SQL statement: R RR (repeatable read) T RS (read stability) S CS (cursor stability) U UR (uncommitted read) L RS isolation, with a <i>lock-clause</i> X RR isolation, with a <i>lock-clause</i> blank The WITH clause was not specified on this statement. The isolation level is recorded in SYSPACKAGE.ISOLATION and in SYSPLAN.ISOLATION.	G

Table 360. SYSIBM.SYSSTMT table column descriptions (continued)

Column name	Data type	Description	Use
STATUS	CHAR(1) NOT NULL WITH DEFAULT	<p>Status of binding the statement:</p> <p>A Distributed - statement uses Db2 private protocol access. The statement will be parsed and executed at the server using defaults for input variables during access path selection.</p> <p>B Distributed - statement uses Db2 private protocol access. The statement will be parsed and executed at the server using values for input variables during access path selection.</p> <p>C Compiled - statement was bound successfully using defaults for input variables during access path selection.</p> <p>D Distributed - statement references a remote object using a three-part name. Db2 will implicitly use DRDA access either because the DBPROTOCOL bind option was not specified (defaults to DRDA), or the bind option DBPROTOCOL(DRDA) was explicitly specified. This option allows the use of three-part names with DRDA access but it requires that the package be bound at the target remote site.</p> <p>E Explain - statement is an SQL EXPLAIN statement. The explain is done at bind time using defaults for input variables during access path selection.</p> <p>F Parsed - statement did not bind successfully and VALIDATE(RUN) was used. The statement will be rebound at execution time using values for input variables during access path selection.</p> <p>G Compiled - statement bound successfully, but REOPT is specified. The statement will be rebound at execution time using values for input variables during access path selection.</p> <p>H Parsed - statement is either a data definition statement or a statement that did not bind successfully and VALIDATE(RUN) was used. The statement will be rebound at execution time using defaults for input variables during access path selection. Data manipulation statements use defaults for input variables during access path selection.</p> <p>I Indefinite - statement is dynamic. The statement will be bound at execution time using defaults for input variables during access path selection.</p>	S

Table 360. SYSIBM.SYSSTMT table column descriptions (continued)

Column name	Data type	Description	Use
STATUS		<p>J Indefinite - statement is dynamic. The statement will be bound at execution time using values for input variables during access path selection.</p> <p>K Control - CALL statement.</p> <p>L Bad - the statement has some allowable error. The bind continues but the statement cannot be executed.</p> <p>M Parsed - statement references a table that is qualified with SESSION and was not bound because the table reference could be for a declared temporary table that will not be defined until the package or plan is run. The SQL statement will be rebound at execution time using values for input variables during access path selection.</p> <p>blank The statement is non-executable, or was bound in a Db2 release prior to Version 5.</p>	
ACCESSPATH	CHAR(1) NOT NULL WITH DEFAULT	<p>For static statements, indicates if the access path for the statement is based on user-specified optimization hints. A value of 'H' indicates that optimization hints were used. A blank value indicates that the access path was determined without the use of optimization hints, or that there is no access path associated with the statement.</p> <p>For dynamic statements, the value is blank.</p>	G
STMTNOI	INTEGER NOT NULL WITH DEFAULT	If the value of STMTNOI is not zero, the column contains the statement number of the statement in the source program.	G
SECTNOI	INTEGER NOT NULL WITH DEFAULT	The section number of the statement.	G
EXPLAINABLE	CHAR(1) NOT NULL WITH DEFAULT	<p>Contains one of the following values:</p> <p>Y Indicates that the SQL statement can be used with the EXPLAIN function and might have rows describing its access path in the owner.PLAN_TABLE.</p> <p>N Indicates that the SQL statement does not have any rows describing its access path in the owner.PLAN_TABLE.</p> <p>blank Indicates that the SQL statement was bound prior to Version 7.</p>	G

Table 360. SYSIBM.SYSSTMT table column descriptions (continued)

Column name	Data type	Description	Use
QUERYNO	INTEGER NOT NULL WITH DEFAULT -1	The query number of the SQL statement in the source program. SQL statements bound prior to Version 7 have a default value of -1. Statements bound in Version 7 or later use the value specified on the QUERYNO clause on SELECT, UPDATE, INSERT, DELETE, EXPLAIN, and DECLARE CURSOR statements. If the QUERYNO clause is not specified, the query number is set to the statement number.	G
PLCREATORTYPE	CHAR(1) NOT NULL WITH DEFAULT	Indicates the type of creator: blank Authorization ID L Role	G

SYSSTOGROUP catalog table

The SYSSTOGROUP table contains one row for each storage group. The schema is SYSIBM.

Column name	Data type	Description	Use
NAME	VARCHAR(128) NOT NULL	Name of the storage group.	G
CREATOR	VARCHAR(128) NOT NULL	Authorization ID of the owner of the storage group.	G
VCATNAME	VARCHAR(24) NOT NULL	Name of the integrated catalog facility catalog.	G
VPASSWORD	VARCHAR(24) NOT NULL	Not used.	N
SPACE	INTEGER NOT NULL	Number of kilobytes of DASD storage allocated to the storage group as determined by the last execution of the STOSPACE utility.	G
SPCDATE	CHAR(5) NOT NULL	Not used.	N
IBMREQD	CHAR(1) NOT NULL	A value of Y indicates that the row was provided with the Db2 product code. For all other values, see Release dependency indicators . The value in this field is not a reliable indicator of release dependencies. RELCREATED should be used instead.	G
CREATEDBY	VARCHAR(128) NOT NULL WITH DEFAULT	Primary authorization ID of the user who created the storage group.	G

Column name	Data type	Description	Use
STATSTIME	TIMESTAMP NOT NULL WITH DEFAULT	If the STOSPACE utility was executed for the storage group, date and time when STOSPACE was last executed.	G
CREATEDTS	TIMESTAMP NOT NULL WITH DEFAULT	Time when the CREATE statement was executed for the storage group.	G
ALTEREDTS	TIMESTAMP NOT NULL WITH DEFAULT	Time when the most recent ALTER STOGROUP statement was executed for the storage group. If no ALTER STOGROUP statement has been applied, ALTEREDTS has the value of CREATEDTS.	G
SPACEF	FLOAT NOT NULL WITH DEFAULT	Kilobytes of DASD storage for the storage group. The value is -1 if statistics have not been gathered. This is an updatable column.	G
DATACLAS	VARCHAR(24) NOT NULL	Name of the SMS data class. Blank if data class is not used.	G
MGMTCLAS	VARCHAR(24) NOT NULL	Name of the SMS management class. Blank if management class is not used.	G
STORCLAS	VARCHAR(24) NOT NULL	Name of the SMS storage class. Blank if storage class is not used.	G
CREATORTYPE	CHAR(1) NOT NULL WITH DEFAULT	Indicates the type of creator: blank Authorization ID L Role	G
RELCREATED	CHAR(1) NOT NULL	The release of Db2 that is used to create the object. Blank if created prior to Version 9. See Release dependency indicators for all other values.	G
<u>FL 502</u> KEYLABEL	VARCHAR(192) NOT NULL WITH DEFAULT	The default key label that is used for encrypting all the table spaces and index spaces using the storage group. Otherwise the value is an empty string	

SYSSTRINGS catalog table

The SYSSTRINGS table contains information about character conversion. Each row describes a conversion from one coded character set to another. The schema is SYSIBM.

Also refer to [Building and using Dynamic Link Libraries \(DLLs\) \(XL C/C++ Programming Guide\)](#) for information on the additional conversions that are supported.

Each row in the table must have a unique combination of values for its INCCSID, OUTCCSID, and IBMREQD columns. Rows for which the value of IBMREQD is N can be deleted, inserted, and updated subject to this uniqueness constraint and to the constraints imposed by a VALIDPROC defined on the table. An inserted row could have values for the INCCSID and OUTCCSID columns that match those of a row for which the value of IBMREQD is Y. Db2 then uses the information in the inserted row instead of the information in the IBM-supplied row. Rows for which the value of IBMREQD is Y cannot be deleted,

inserted, or updated. For information about the use of inserted rows for character conversion, see [How an entry in SYSIBM.SYSSTRINGS works with character conversion \(Db2 Installation and Migration\)](#).

Db2 has two methods for character conversions and applies them in the following order:

1. Conversions specified by the various combinations of the INCCSID and OUTCCSID columns in the SYSIBM.SYSSTRINGS catalog table.
2. Conversions provided by z/OS support for Unicode. For more information, see [z/OS Unicode Services User's Guide and Reference](#).

If neither of these methods can be used for a particular character conversion, Db2 returns an error.

Table 361. SYSIBM.SYSSTRINGS table column descriptions

Column name	Data type	Description	Use
INCCSID	INTEGER NOT NULL	The source CCSID for the character conversion represented by this row. The value of the source CCSID must be in the range of 1 to 65533 and must not be the same as the value for the OUTCCSID column.	G
OUTCCSID	INTEGER NOT NULL	The target CCSID for the character conversion represented by this row. The value of the target CCSID must be in the range of 1 to 65533 and must not be the same as the value for the INCCSID column.	G
TRANSTYPE	CHAR(2) NOT NULL	Indicates the nature of the conversion. Values can be: GG GRAPHIC to GRAPHIC MM EBCDIC MIXED to EBCDIC MIXED MS EBCDIC MIXED to SBCS PM ASCII MIXED to EBCDIC MIXED PS ASCII MIXED to SBCS SM SBCS to EBCDIC MIXED SS SBCS to SBCS MP EBCDIC MIXED to ASCII MIXED PP ASCII MIXED to ASCII MIXED SP SBCS to ASCII MIXED	G
ERRORBYTE	CHAR(1) FOR BIT DATA (Nulls are allowed)	The byte used in the conversion table as an error byte. Any non-null value that is specified for the ERRORBYTE column must not be the same as the value that is specified for the SUBBYTE column. Null indicates the absence of an error byte.	S

Table 361. SYSIBM.SYSSTRINGS table column descriptions (continued)

Column name	Data type	Description	Use
SUBBYTE	CHAR(1) FOR BIT DATA (Nulls are allowed)	The byte used in the conversion table as a substitution character. Any non-null value that is specified for the SUBBYTE column must not be the same as the value that is specified for the ERRORBYTE column. Null indicates the absence of a substitution character.	S
TRANSPROC	VARCHAR(24) NOT NULL WITH DEFAULT	The name of a module or blanks. A nonblank value must conform to the rules for z/OS program names. If IBMREQD is 'N', a nonblank value is the name of a conversion procedure provided by the user. The first five characters of the name of a user-provided conversion procedure must not be 'DSNXV'; these characters are used to distinguish user-provided conversion procedures from Db2 modules that contain DBCS conversion tables. If IBMREQD is 'Y', a nonblank value is the name of a Db2 module that contains DBCS conversion tables.	G
IBMREQD	CHAR(1) NOT NULL	A value of Y indicates that the row was provided with the Db2 product code. For all other values, see Release dependency indicators . The value in this field is not a reliable indicator of release dependencies.	G
TRANSTAB	VARCHAR(256) FOR BIT DATA NOT NULL WITH DEFAULT	Either a 256-byte conversion table or an empty (0 length) string.	S

SYSSYNONYMS catalog table

The SYSSYNONYMS table contains one row for each synonym of a table or view. The schema is SYSIBM.

Table 362. SYSIBM.SYSSYNONYMS table column descriptions

Column name	Data type	Description	Use
NAME	VARCHAR(128) NOT NULL	Synonym for the table or view.	G
CREATOR	VARCHAR(128) NOT NULL	Authorization ID of the owner of the synonym.	G
TBNAME	VARCHAR(128) NOT NULL	Name of the table or view.	G
TBCREATOR	VARCHAR(128) NOT NULL	The schema of the table or view.	G

Table 362. SYSIBM.SYSSYNONYMS table column descriptions (continued)

Column name	Data type	Description	Use
IBMREQD	CHAR(1) NOT NULL	A value of Y indicates that the row was provided with the Db2 product code. For all other values, see Release dependency indicators . The value in this field is not a reliable indicator of release dependencies. RELCREATED should be used instead.	G
CREATEDBY	VARCHAR(128) NOT NULL WITH DEFAULT	Primary authorization ID of the user who created the synonym.	G
CREATEDTS	TIMESTAMP NOT NULL WITH DEFAULT	Time when the CREATE statement was executed for the synonym. The value is '0001-01.01.00.00.000000' for synonyms created in a Db2 release prior to Version 5.	G
CREATORTYPE	CHAR(1) NOT NULL WITH DEFAULT	Indicates the type of creator: blank Authorization ID L Role	G
RELCREATED	CHAR(1) NOT NULL	The release of Db2 that is used to create the object. Blank if created prior to Version 9. See Release dependency indicators for all other values.	G

SYSTABAUTH catalog table

The SYSTABAUTH table records the privileges that users hold on tables and views. The schema is SYSIBM.

Column name	Data type	Description	Use
GRANTOR	VARCHAR(128) NOT NULL	Authorization ID or role of the user who granted the privileges. Could also be PUBLIC.	G
GRANTEE	VARCHAR(128) NOT NULL	Authorization ID or role of the user who holds the privileges or the name of an application plan or package that uses the privileges. PUBLIC for a grant to PUBLIC.	G
GRANTEETYPE	CHAR(1) NOT NULL	Type of grantee: blank An authorization ID L Role P An application plan or a package. The grantee is a package if COLLID is not blank.	G

Column name	Data type	Description	Use
DBNAME	VARCHAR(24) NOT NULL	If the privileges were received from a user with DBADM, DBCTRL, or DBMAINT authority, DBNAME is the name of the database on which the GRANTOR has that authority. Otherwise, DBNAME is blank.	G
SCREATOR	VARCHAR(128) NOT NULL	If the row of SYSIBM.SYSTABAUTH was created as a result of a CREATE VIEW statement, SCREATOR is the schema of a table or view referred to in the CREATE VIEW statement. Otherwise, SCREATOR is the same as TCREATOR.	G
STNAME	VARCHAR(128) NOT NULL	If the row of SYSIBM.SYSTABAUTH was created as a result of a CREATE TABLE statement or a materialized query table, STNAME is the name of a table or view referred to in the fullselect of the CREATE TABLE statement.	G
TCREATOR	VARCHAR(128) NOT NULL	The schema of the table or view.	G
TTNAME	VARCHAR(128) NOT NULL	Name of the table or view.	G
AUTHHOWGOT	CHAR(1) NOT NULL WITH DEFAULT	Authorization level of the user from whom the privileges were received. This authorization level is not necessarily the highest authorization level of the grantor. blank Not applicable B System DBADM C DBCTRL D DBADM E SECADM G ACCESSCTRL K SQLADM L SYSCTRL M DBMAINT S SYSADM T DATAACCESS	G

Column name	Data type	Description	Use
—	CHAR(12) NOT NULL	Internal use only.	I
DATEGRANTED	CHAR(6) NOT NULL	Not used.	N
TIMEGRANTED	CHAR(8) NOT NULL	Not used.	N
UPDATECOLS	CHAR(1) NOT NULL	The value of this column is blank if the value of UPDATEAUTH applies uniformly to all columns of the table or view. The value is an asterisk (*) if the value of UPDATEAUTH applies to some columns but not to others. In this case, rows will exist in SYSIBM.SYSCOLAUTH with matching timestamps and PRIVILEGE = blank. These rows list the columns on which update privileges have been granted.	G
ALTERAUTH	CHAR(1) NOT NULL	Whether the GRANTEE can alter the table: blank Privilege is not held G Privilege is held with the GRANT option Y Privilege is held without the GRANT option	G
DELETEAUTH	CHAR(1) NOT NULL	Whether the GRANTEE can delete rows from the table or view: blank Privilege is not held G Privilege is held with the GRANT option Y Privilege is held without the GRANT option	G
INDEXAUTH	CHAR(1) NOT NULL	Whether the GRANTEE can create indexes on the table: blank Privilege is not held G Privilege is held with the GRANT option Y Privilege is held without the GRANT option	G

Column name	Data type	Description	Use
INSERTAUTH	CHAR(1) NOT NULL	Whether the GRANTEE can insert rows into the table or view: blank Privilege is not held G Privilege is held with the GRANT option Y Privilege is held without the GRANT option	G
SELECTAUTH	CHAR(1) NOT NULL	Whether the GRANTEE can select rows from the table or view: blank Privilege is not held G Privilege is held with the GRANT option Y Privilege is held without the GRANT option	G
UPDATEAUTH	CHAR(1) NOT NULL	Whether the GRANTEE can update rows of the table or view: blank Privilege is not held G Privilege is held with the GRANT option Y Privilege is held without the GRANT option	G
IBMREQD	CHAR(1) NOT NULL	A value of Y indicates that the row was provided with the Db2 product code. For all other values, see Release dependency indicators . The value in this field is not a reliable indicator of release dependencies.	G
GRANTEELLOCATION	VARCHAR(128) NOT NULL WITH DEFAULT	Not used.	N
LOCATION	VARCHAR(128) NOT NULL WITH DEFAULT	Not used.	N
COLLID	VARCHAR(128) NOT NULL WITH DEFAULT	If the GRANTEE is a package, its collection name. Otherwise, the value is blank.	G
CONTOKEN	CHAR(8) NOT NULL WITH DEFAULT FOR BIT DATA	If the GRANTEE is a package, the consistency token of the DBRM from which the package was derived. Otherwise, the value is blank.	S

Column name	Data type	Description	Use
CAPTUREAUTH	CHAR(1) NOT NULL WITH DEFAULT	Not used.	N
REFERENCESAUTH	CHAR(1) NOT NULL WITH DEFAULT	Whether the GRANTEE can create or drop referential constraints in which the table is a parent. blank Privilege is not held G Privilege held with the GRANT option Y Privilege held without the GRANT option	G
REFCOLS	CHAR(1) NOT NULL WITH DEFAULT	The value of this column is blank if the value of REFERENCESAUTH applies uniformly to all columns of the table. The value is an asterisk(*) if the value of REFERENCESAUTH applies to some columns but not to others. In this case, rows will exist in SYSIBM.SYSCOLAUTH with PRIVILEGE = R and matching timestamps that list the columns on which reference privileges have been granted.	G
GRANTEDTS	TIMESTAMP NOT NULL WITH DEFAULT	Time when the GRANT statement was executed.	G
TRIGGERAUTH	CHAR(1) NOT NULL WITH DEFAULT	Whether the GRANTEE can create triggers in which the table is named as the subject table: blank Privilege is not held G Privilege is held with the GRANT option Y Privilege is held without the GRANT option	G
GRANTORTYPE	CHAR(1) NOT NULL WITH DEFAULT	Indicates the type of grantor: blank Authorization ID L Role	G
SYS_START	TIMESTAMP(12) NOT NULL GENERATED ALWAYS AS ROW BEGIN	Reserved for future IBM use.The row-begin column of the SYSTEM_TIME period, for system-period data versioning.	G
SYS_END	TIMESTAMP(12) NOT NULL GENERATED ALWAYS AS ROW END	Reserved for future IBM use.The row-end column of the SYSTEM_TIME period, for system-period data versioning.	G

Column name	Data type	Description	Use
TRANS_START	TIMESTAMP(12) NOT NULL GENERATED ALWAYS AS TRANSACTION START ID	Reserved for future IBM use.	G
UNLOADAUTH	CHAR(1) NOT NULL WITH DEFAULT	Whether the GRANTEE can use the UNLOAD utility to unload data: blank Privilege is not held G Privilege is held with the GRANT option Y Privilege is held without the GRANT option	G

SYSTABCONST catalog table

The SYSTABCONST table contains one row for each unique constraint (primary key or unique key) created in DB2 version 7 or later. The schema is SYSIBM.

Table 363. SYSIBM.SYSTABCONST table column descriptions

Column name	Data type	Description	Use
CONSTNAME	VARCHAR(128) NOT NULL	Name of the constraint.	G
TBCREATOR	VARCHAR(128) NOT NULL	The schema of the table on which the constraint is defined.	G
TBNAME	VARCHAR(128) NOT NULL	Name of the table on which the constraint is defined.	G
CREATOR	VARCHAR(128) NOT NULL	Authorization ID under which the constraint was created.	G
TYPE	CHAR(1) NOT NULL	Type of constraint: F Foreign key P Primary key U Unique key	G
IXOWNER	VARCHAR(128) NOT NULL	The schema of the index enforcing the constraint or blank if index has not been created yet.	G
IXNAME	VARCHAR(128) NOT NULL	Name of the index enforcing the constraint or blank if index has not been created yet.	G

Table 363. SYSIBM.SYSTABCONST table column descriptions (continued)

Column name	Data type	Description	Use
CREATEDTS	TIMESTAMP NOT NULL	Time when the statement to create the constraint was executed.	G
IBMREQD	CHAR(1) NOT NULL WITH DEFAULT 'N'	A value of Y indicates that the row was provided with the Db2 product code. For all other values, see Release dependency indicators . The value in this field is not a reliable indicator of release dependencies. RELCREATED should be used instead.	G
COLCOUNT	SMALLINT NOT NULL	Number of columns in the constraint.	G
RELCREATED	CHAR(1) NOT NULL	The release of Db2 that is used to create the object. Blank if created prior to DB2 9. See Release dependency indicators for all other values.	G

SYSTABLEPART catalog table

The SYSTABLEPART table contains one row for each nonpartitioned table space and one row for each partition of a partitioned table space. The schema is SYSIBM.

Column name	Data type	Description	Use
PARTITION	SMALLINT NOT NULL	Partition number; 0 if table space is not partitioned.	G
TSNAME	VARCHAR(24) NOT NULL	Name of the table space.	G
DBNAME	VARCHAR(24) NOT NULL	Name of the database that contains the table space.	G
IXNAME	VARCHAR(128) NOT NULL	Name of the partitioning index. This column is blank unless the table uses index-controlled partitioning.	G
IXCREATOR	VARCHAR(128) NOT NULL	The schema of the partitioning index. This column is blank unless the table uses index-controlled partitioning.	G

Column name	Data type	Description	Use
PQTY	INTEGER NOT NULL	<p>For user-managed data sets, the value is the primary space allocation in units of 4 KB storage blocks or -1.</p> <p>PQTY is based on a value of PRIQTY in the appropriate CREATE or ALTER TABLESPACE statement. However, unlike PQTY, PRIQTY asks for space in 1 KB units.</p> <p>A value of -1 indicates that either of the following cases is true:</p> <ul style="list-style-type: none"> • PRIQTY was not specified for a CREATE TABLESPACE statement or for any subsequent ALTER TABLESPACE statements. • -1 was the most recently specified value for PRIQTY, either on the CREATE TABLESPACE statement or a subsequent ALTER TABLESPACE statement. 	G
SQTY	SMALLINT NOT NULL	<p>For user-managed data sets, the value is the secondary space allocation in units of 4 KB storage blocks or -1.</p> <p>SQTY is based on a value of SECQTY in the appropriate CREATE or ALTER TABLESPACE statement. Unlike SQTY, however, SECQTY asks for space in 1 KB units.</p> <p>A value of -1 indicates that either of the following cases is true:</p> <ul style="list-style-type: none"> • SECQTY was not specified for a CREATE TABLESPACE statement or for any subsequent ALTER TABLESPACE statements. • -1 was the most recently specified value for SECQTY, either on the CREATE TABLESPACE statement or a subsequent ALTER TABLESPACE statement. <p>If the value does not fit into the column, the value of the column is 32767. See the description of column SECQTYI.</p>	G
STORATYPE	CHAR(1) NOT NULL	<p>Type of storage allocation:</p> <p>E Explicit (storage group not used)</p> <p>I Implicit (storage group used)</p> <p>This column is not used for rows that represent catalog table spaces. Catalog data sets are managed by Db2</p>	G
STORNAME	VARCHAR(128) NOT NULL	<p>Name of storage group used for space allocation. Blank if storage group not used.</p> <p>This column is not used for rows that represent catalog table spaces. Catalog data sets are managed by Db2</p>	G
VCATNAME	VARCHAR(24) NOT NULL	<p>Name of integrated catalog facility catalog used for space allocation.</p> <p>This column is not used for rows that represent catalog table spaces. Catalog data sets are managed by Db2</p>	G

Column name	Data type	Description	Use
CARD	INTEGER NOT NULL	Number of rows in the table space or partition or, if the table space is a LOB table space, the number of LOBs in the table space. The value is '2147483647' if the number of rows is greater than or equal to '2147483647'. The value is -1 if statistics were not gathered.	G
FARINDREF	INTEGER NOT NULL	Number of rows that are relocated far from their original page. The value is -1 if statistics were not gathered. Not applicable if the table space is a LOB table space.	S
NEARINDREF	INTEGER NOT NULL	Number of rows that are relocated near their original page. The value is -1 if statistics were not gathered. Not applicable if the table space is a LOB table space.	S
PERCACTIVE	SMALLINT NOT NULL	Percentage of space occupied by rows of data from active tables. The value is -1 if statistics were not gathered. The value is -2 if the table space is a LOB table space. This value is not applicable for understanding data distribution in tables that are organized for hash access.	S
PERCDROP	SMALLINT NOT NULL	Percentage of space that rows of dropped tables occupy. The value is -1 if statistics were not gathered. The value is 0 for segmented table spaces. Not applicable if the table is an auxiliary table.	S
IBMREQD	CHAR(1) NOT NULL	A value of Y indicates that the row was provided with the Db2 product code. For all other values, see Release dependency indicators . The value in this field is not a reliable indicator of release dependencies. RELCREATED should be used instead.	G
LIMITKEY	VARCHAR(765) NOT NULL	The high value of the partition in external format. If the table space was converted from index-controlled partitioning to table-controlled partitioning, the value is the highest possible value for an ascending key, or the lowest possible value for a descending key. If the table is not in a partition-by-range table space, the value is an empty string. This column can contain a mixture of values with differing formats: <ul style="list-style-type: none"> • Date and time values are delimited by single quotation marks (for example, '2001-01-01'). However, values that were added before Db2 11 do not contain these delimiters. • When comma decimal point indicators are used, a space follows any comma delimiter in the value. The comma decimal point indicator is used when the DECIMAL POINT IS field setting is , (comma) or a COBOL program that executes the ALTER statement uses the COMMA processing option. No spaces follow comma delimiters when period decimal point indicators are used, or for values added before Db2 11. 	S

Column name	Data type	Description	Use
FREEPAGE	SMALLINT NOT NULL	Number of pages loaded before a page is left as free space.	G
PCTFREE	SMALLINT NOT NULL	Percentage of each page that is left as free space.	G
CHECKFLAG	CHAR(1) NOT NULL WITH DEFAULT	<p>blank The table space is not a partition, or does not contain rows that might violate referential constraints, check constraints, or both.</p> <p>C The table space partition is in a check-pending status and the table contains rows that can violate referential constraints, check constraints, or both.</p> <p>D The inline length of the LOB column that is associated with this LOB table space was decremented when the inline length was altered.</p> <p>I The inline length of the LOB column that is associated with this LOB table space was incremented when the inline length was altered.</p>	G
CHECKRID	CHAR(4) NOT NULL WITH DEFAULT FOR BIT DATA	Not used.	N
SPACE	INTEGER NOT NULL WITH DEFAULT	<p>Number of kilobytes of DASD storage that is allocated to the table space partition, as determined by the last execution of the STOSPACE utility or RUNSTATS utility.</p> <p>0 The STOSPACE or RUNSTATS utility was not run.</p> <p>-1 The table space was defined with the DEFINE NO clause, which defers the physical creation of the data sets until data is first inserted into one of the partitions, and data has yet to be inserted.</p> <p>-2 The value exceeds the maximum size for an integer value. See the SPACEF column value.</p> <p>Nonzero or nonnegative value An auxiliary table in the LOB table space.</p> <p>The STOSPACE utility updates this value if the table space is related to a storage group. The RUNSTATS utility updates this value when RUNSTATS TABLESPACE is run with UPDATE(ALL) or UPDATE(SPACE).</p>	G

Column name	Data type	Description	Use
COMPRESS	CHAR(1) NOT NULL WITH DEFAULT	<ul style="list-style-type: none"> For a table space partition, indicates the COMPRESS attribute for the partition. For a nonpartitioned table space, indicates the COMPRESS attribute for the table space. <p>Values for the column can be:</p> <p>Y The table space or partition is defined to use compression. If the table space is not a LOB table space, the compression algorithm is determined by the TS_COMPRESSION_TYPE subsystem parameter.</p> <p>F FL 509The table space or partition is defined to use fixed-length compression.</p> <p>H FL 509The table space or partition is defined to use Huffman compression.</p> <p>blank The table space or partition is not defined to use compression.</p>	G
PAGESAVE	SMALLINT NOT NULL WITH DEFAULT	<p>Percentage of pages that are saved in the table space or partition as a result of defining the table space with compression. For example, a value of 25 indicates a savings of 25 percent, so that the pages required are only 75 percent of what would be required without data compression. The calculation includes overhead bytes for each row, the bytes required for dictionary, and the bytes required for the current FREEPAGE and PCTFREE specification for the table space or partition. This calculation is based on an average row length, and the result varies depending on the actual lengths of the rows. The value is 0 if there are no savings from using data compression, or if statistics were not gathered. The value can be negative, if for example, data compression causes an increase in the number of pages in the data set.</p>	S
STATSTIME	TIMESTAMP NOT NULL WITH DEFAULT	<p>If RUNSTATS or another utility with inline statistics updated the statistics, the date and time when the last utility invocation updated the statistics. The default value is '0001-01-01-00.00.00.000000'. The default value indicates that statistics were not collected. This column can be updated.</p>	G

Column name	Data type	Description	Use
GBPCACHE	CHAR(1) NOT NULL WITH DEFAULT	Group buffer pool cache option that is specified for this table space or table space partition. A Changed and unchanged pages are cached in the group buffer pool. N No data is cached in the group buffer pool. S Only changed system pages, such as space map pages that do not contain actual data values, are cached in the group buffer pool. blank Only changed pages are cached in the group buffer pool.	G
CHECKRID5B	CHAR(5) NOT NULL WITH DEFAULT FOR BIT DATA	Blank if the table or partition is not in a check-pending status (CHECKFLAG is blank), or if the table space is not partitioned. Otherwise, the RID of the first row of the table space partition that can violate referential constraints, check constraints, or both; or the value is X'0000000000', indicating that any row can violate referential constraints.	S
TRACKMOD	CHAR(1) NOT NULL WITH DEFAULT	Whether to track the page modifications in the space map pages: N No blank Yes This column is not applicable for LOB table spaces.	G
EPOCH	INTEGER NOT NULL WITH DEFAULT	A number that increments whenever a utility operation that changes the location of rows in a table occurs.	G
SECQTYI	INTEGER NOT NULL WITH DEFAULT	Secondary space allocation in units of 4KB storage. For user-managed data sets, the value is the secondary space allocation in units of 4KB blocks.	G
CARDF	FLOAT NOT NULL WITH DEFAULT -1	Number of rows in the table space or partition, or if the table space is a LOB table space, the number of LOBs in the table space. The value is -1 if statistics were not gathered.	G
IPREFIX	CHAR(1) NOT NULL WITH DEFAULT 'I'	The first character of the instance qualifier for the data set name for the table space or partition. 'I' or 'J' are the only valid characters for this field. The default is 'I'.	G
ALTEREDTS	TIMESTAMP NOT NULL WITH DEFAULT	Time when the most recent ALTER TABLESPACE statement was executed for the table space or partition. If no ALTER TABLESPACE statement was applied, the value is '0001-01-01.00.00.00.000000'.	G

Column name	Data type	Description	Use
SPACEF	FLOAT(8) NOT NULL WITH DEFAULT -1	DASD storage in KB. The value is -1 if statistics were not gathered. The value might be nonzero for an auxiliary table in the LOB table space. This column can be updated.	G
DSNUM	INTEGER NOT NULL WITH DEFAULT -1	Number of data sets. The value is -1 if statistics were not gathered. This column can be updated.	G
EXTENTS	INTEGER NOT NULL WITH DEFAULT -1	Number of data set extents. The value is -1 if statistics were not gathered. This column can be updated. This value is only for the last DSNUM for the object.	G
LOGICAL_PART	SMALLINT NOT NULL WITH DEFAULT	The logical partition number (logical ascending or descending order) for partitioned table spaces. The physical partition number is kept in column PARTITION. LOGICAL_PART is 0 for nonpartitioned table spaces. For partitioned table spaces that were created before Version 8, LOGICAL_PART is originally 0, but might be changed later to a nonzero value by processes such as conversion to table-controlled partitioning.	G
LIMITKEY_INTERNAL	VARCHAR(512) NOT NULL WITH DEFAULT FOR BIT DATA	The highest value of the limit key of the partition in an internal format. If the table uses index-controlled partitioning instead of table-controlled partitioning or the table is not partitioned, the value is an empty string. If the table space was converted from index-controlled partitioning to table-controlled partitioning, the value is the highest possible value for an ascending key, or the lowest possible value for a descending key. If any column of the key has a field procedure, the internal format is the encoded form of the value.	S
OLDEST_VERSION	SMALLINT NOT NULL WITH DEFAULT	The version number of the oldest format of data in the table part and any image copies at the part level.	G
CREATEDTS	TIMESTAMP NOT NULL WITH DEFAULT	Time when the partition was created.	G
AVGROWLEN	INTEGER NOT NULL WITH DEFAULT -1	Average length of rows for the tables in the table space or part. If the table space or part is compressed, the value is the compressed row length. If the table space or part is not compressed, the value is the uncompressed row length. The value is -1 if statistics were not gathered.	G
FORMAT	CHAR(1) NOT NULL WITH DEFAULT	Indicates the format of the rows in the table space or partition: R Indicates reordered row format. blank Indicates basic row format or a LOB table space.	G

Column name	Data type	Description	Use
RELCREATED	CHAR(1) NOT NULL	The release of Db2 that is used to create the object. Blank if created before Version 9. See Release dependency indicators for all other values.	G
REORG_LR_TS	TIMESTAMP NOT NULL WITH DEFAULT	The time when the REORG or LOAD REPLACE utility last occurred. The default value is '0001-01-01.00.00.00.000000'.	G
HASHSPACE	BIGINT NOT NULL WITH DEFAULT	For partition-by-range (UTS) table spaces, the amount of space, in KB, specified at the partition level to override the space specification at the table level. If no override is provided it is the same as the value of HASHSPACE in the SYSIBM.SYSTABLESPACE catalog table. For partition-by-growth table spaces, this value is zero.	G
HASHDATAPAGES	BIGINT NOT NULL WITH DEFAULT	For partition-by-range table spaces, the number of hash data pages that correspond to the value of the HASHSPACE column for each partition. The value is 0 for table spaces that are changed to use hash access but not reorganized. For partition-by-growth table spaces, the value is zero.	G
RBA_FORMAT	CHAR(1) NOT NULL WITH DEFAULT	The RBA and LRSN format for the page sets of the table partition: B The page sets are still in the basic 6-byte format. E The page sets are converted to the extended 10-byte format. U The format is undefined because DEFINE NO was specified when the table space was created. blank The page sets are still in the basic 6-byte format, the table partition was created before Db2 11 new-function mode (NFM), and no utility that sets the RBA_FORMAT value was run for the table partition in Db2 11 NFM or higher.	G
PCTFREE_UPD	SMALLINT NOT NULL WITH DEFAULT	The percentage of free space that is reserved for updates to variable length records, as defined when the object as created or altered.	G
PCTFREE_UPD_CALC	SMALLINT NOT NULL WITH DEFAULT	The percentage of free space that is reserved for updates to variable length records, which are calculated by Db2 or utilities.	G

Column name	Data type	Description	Use
TYPE	CHAR(1) WITH DEFAULT NULL	<p>The type of partition.</p> <p>blank The table space was created without the LOB or MEMBER CLUSTER options. If the DSSIZE column is zero, the table space is not greater than 64 gigabytes.</p> <p>G The table space was defined with the MAXPARTITIONS option (a partitioned-by-growth table space) with the underlying structure of a universal table space.</p> <p>L The table space can be greater than 64 gigabytes.</p> <p>O The table space was defined with the LOB option (the table space is a LOB table space).</p> <p>P Implicit table space created for XML columns.</p> <p>R partition-by-range table space.</p> <p>This value might be NULL for table spaces that were created before Db2 12. In that case, Db2 uses the value from the SYSTABLESPACE.TYPE column.</p>	G
PAGENUM	CHAR(1) NOT NULL WITH DEFAULT 'A'	<p>Format of pages for the table space and indexes created on tables in the table space, indicating absolute or relative page numbering.</p> <p>A Indicates absolute addressing so that PAGENUM contains the embedded partition number.</p> <p>R Indicates relative addressing so that PAGENUM contains only the relative page number.</p>	G
BPOOL	CHAR(8) WITH DEFAULT NULL	<p>Name of the buffer pool used for the partition.</p> <p>The value might be NULL for table spaces that were created before Db2 12. In that case, Db2 uses the value in the SYSTABLESPACE.BPOOL column.</p>	G
PGSIZE	SMALLINT WITH DEFAULT NULL	<p>Size of pages in the table space in kilobytes.</p> <p>The value might be NULL for table spaces that were created before Db2 12. In that case, Db2 uses the value in the SYSTABLESPACE.PGSIZE column.</p>	G
DSSIZE	INTEGER WITH DEFAULT NULL	<p>Maximum size on a partitioned table space data set. 0 for a nonpartitioned table space.</p> <p>The value might be NULL for table spaces that were created before Db2 12. In that case, Db2 uses the value in SYSTABLESPACE.DSSIZE column.</p>	G

Column name	Data type	Description	Use
MEMBER_CLUSTER	CHAR(1) WITH DEFAULT NULL	<p>Indicates whether MEMBER CLUSTER is specified for the table space.</p> <p>Y MEMBER CLUSTER is specified for the table space.</p> <p>blank MEMBER CLUSTER is not specified for the table space.</p> <p>The value might be NULL for table spaces that were created before Db2 12. In that case, Db2 uses the value in the SYSTABLESPACE.MEMBER_CLUSTER column.</p>	G
COMPRESSRATIO	SMALLINT NOT NULL WITH DEFAULT	<p>Average percentage of bytes saved by compression on each compressed data record in the partition when the table space is defined with compression. This calculation includes overhead bytes for each row. The value is based on an average row length and varies depending on the actual length of the data rows.</p> <p>For example, a value of 25 indicates that the average compressed record size is approximately 75% the size of the uncompressed record.</p> <p>The value is -1 or 0 in the following cases:</p> <p>-1 This value is not collected.</p> <p>0 No compression exists or the average compressed record length is the same as or longer than the uncompressed record length.</p>	G

Column name	Data type	Description	Use
FL 509 COMPRESS_USED	CHAR(1) WITH DEFAULT NULL	<p>For a partitioned table space, this column indicates whether the partition is compressed. If the partition is compressed, the column indicates which compression algorithm is used.</p> <p>For a nonpartitioned table space, this column indicates whether the table space is compressed. If the table space is compressed, the column indicates which compression algorithm is used.</p> <p>In rare cases, this column is not updated when compression occurs. For more information, see Determining the effectiveness of compression (Db2 Performance).</p> <p>F Indicates that the table space or partition is compressed with fixed-length compression</p> <p>H Indicates that the table space or partition is compressed with Huffman compression</p> <p>blank If the table space is a LOB table space and COMPRESS is Y, zEnterprise data compression (zEDC) hardware manages compression, if the hardware is available. Otherwise the table space or partition is not compressed.</p> <p>See Support for compressing LOB data (Db2 for z/OS What's New?).</p> <p>NULL The object was created before catalog level V12R1M509, and the value is unknown. The LOAD, REORG, RUNSTATS, RECOVER, or REPAIR CATALOG utility can be used to update this column for objects with a COMPRESS_USED value of NULL.</p>	G

SYSTABLEPART_HIST catalog table

The SYSTABLEPART_HIST table contains rows from the SYSTABLEPART table. The schema is SYSIBM.

Rows are added or changed in this table when RUNSTATS collects history statistics. Rows in this table can also be inserted, updated, and deleted.

Table 364. SYSIBM.SYSTABLEPART_HIST table column descriptions

Column name	Data type	Description	Use
PARTITION	SMALLINT NOT NULL	Partition number. 0 if table space is not partitioned.	G
TSNAME	VARCHAR(24) NOT NULL	Name of the table space.	G

Table 364. SYSIBM.SYSTABLEPART_HIST table column descriptions (continued)

Column name	Data type	Description	Use
DBNAME	VARCHAR(24) NOT NULL	Name of the database that contains the table space.	G
PQTY	INTEGER NOT NULL	<p>For user-managed data sets, the value is the primary space allocation in units of 4 KB storage blocks or -1.</p> <p>For user-specified values of PRIQTY other than -1, the value is set to the primary space allocation only if RUNSTATS TABLESPACE with UPDATE(ALL) or UPDATE(SPACE) is executed; otherwise, the value is zero. PQTY is based on a value of PRIQTY in the appropriate CREATE or ALTER TABLESPACE statement. Unlike PQTY, however, PRIQTY asks for space in 1 KB units.</p> <p>A value of -1 indicates that either of the following cases is true:</p> <ul style="list-style-type: none"> • PRIQTY was not specified for a CREATE TABLESPACE statement or for any subsequent ALTER TABLESPACE statements. • -1 was the most recently specified value for PRIQTY, either on the CREATE TABLESPACE statement or a subsequent ALTER TABLESPACE statement. <p>If a storage group is not used, the value is 0.</p>	G
SECQTYI	INTEGER NOT NULL	<p>For user-managed data sets, the value is the secondary space allocation in units of 4 KB storage blocks or -1.</p> <p>For user-specified values of SECQTY other than -1, the value is set to the secondary space allocation only if RUNSTATS TABLESPACE with UPDATE(ALL) or UPDATE(SPACE) is executed; otherwise, the value is zero. SQTY is based on a value of SECQTY in the appropriate CREATE or ALTER TABLESPACE statement. Unlike SQTY, however, SECQTY asks for space in 1 KB units.</p> <p>A value of -1 indicates that either of the following cases is true:</p> <ul style="list-style-type: none"> • SECQTY was not specified for a CREATE TABLESPACE statement or for any subsequent ALTER TABLESPACE statements. • -1 was the most recently specified value for SECQTY, either on the CREATE TABLESPACE statement or a subsequent ALTER TABLESPACE statement. <p>If a storage group is not used, the value is 0.</p>	G
FARINDREF	INTEGER NOT NULL WITH DEFAULT -1	Number of rows that have been relocated far from their original page. The value is -1 if statistics have not been gathered. Not applicable if the table space is a LOB table space.	S

Table 364. SYSIBM.SYSTABLEPART_HIST table column descriptions (continued)

Column name	Data type	Description	Use
NEARINDREF	INTEGER NOT NULL WITH DEFAULT -1	Number of rows that have been relocated near their original page. The value is -1 if statistics have not been gathered. Not applicable if the table space is a LOB table space.	S
PERCACTIVE	SMALLINT NOT NULL WITH DEFAULT -1	Percentage of space occupied by rows of data from active tables. The value is -1 if statistics have not been gathered. The value is -2 if the table space is a LOB table space.	S
PERCDROP	SMALLINT NOT NULL WITH DEFAULT -1	Percentage of space occupied by rows of dropped tables. The value is -1 if statistics have not been gathered. The value is 0 for segmented table spaces. Not applicable if the table is an auxiliary table.	S
SPACEF	FLOAT(8) NOT NULL WITH DEFAULT -1	Number of kilobytes of DASD storage allocated to the table space partition. The value is -1 if statistics have not been gathered.	G
PAGESAVE	SMALLINT NOT NULL	<p>Percentage of pages saved in the table space or partition as a result of defining the table space with compression. For example, a value of 25 indicates a savings of 25 percent, so that the pages required are only 75 percent of what would be required without data compression.</p> <p>The calculation includes overhead bytes for each row, the bytes required for dictionary, and the bytes required for the current FREEPAGE and PCTFREE specification for the table space or partition. This calculation is based on an average row length, and the result varies depending on the actual lengths of the rows.</p> <p>The value is 0 if there are no savings from using data compression, or if statistics have not been gathered. The value can be negative, if for example, data compression causes an increase in the number of pages in the data set.</p>	S
STATSTIME	TIMESTAMP NOT NULL	If RUNSTATS or another utility with inline statistics updated the statistics, the date and time when the last utility invocation updated the statistics. The default value is '0001-01-01-00.00.00.000000'. The default value indicates that statistics were not collected. This column can be updated.	G
CARDF	FLOAT(8) NOT NULL WITH DEFAULT -1	Number of rows in the table space or partition, or if the table space is a LOB table space, the number of LOBS in the table space. The value is '-1' if statistics have not been gathered.	S
EXTENTS	INTEGER NOT NULL WITH DEFAULT -1	Number of data set extents. The value is '-1' if statistics have not been gathered. This value is only for the last DSNUM for the object.	G

Table 364. SYSIBM.SYSTABLEPART_HIST table column descriptions (continued)

Column name	Data type	Description	Use
DSNUM	INTEGER NOT NULL WITH DEFAULT -1	Data set number within the table space. For partitioned table spaces, this value corresponds to the partition number for a single partition copy, or 0 for a copy of an entire partitioned table space or index space. The value is '-1' if statistics have not been gathered.	G
IBMREQD	CHAR(1) NOT NULL WITH DEFAULT 'N'	A value of Y indicates that the row was provided with the Db2 product code. For all other values, see Release dependency indicators . The value in this field is not a reliable indicator of release dependencies.	G
AVGROWLEN	INTEGER NOT NULL WITH DEFAULT -1	Average length of rows for the tables in the table space or part. If the table space or part is compressed, the value is the compressed row length. If the table space or part is not compressed, the value is the uncompressed row length. The value is '-1' if statistics have not been gathered.	G

SYSTABLES catalog table

The SYSTABLES table contains one row for each table, view, or alias. The schema is SYSIBM. Each SYSTABLES table row indicates whether the object that it describes is a table, view, or alias, its name, who created it, the database that it belongs to, the table space it belongs to, and other information. The SYSTABLES table also has a REMARKS column in which you can store your own information about the table in question.

For an example query for the SYSTABLES catalog table, see [Retrieving catalog information about a table \(Db2 Administration Guide\)](#).

Table 365. SYSIBM.SYSTABLES table column descriptions

Column name	Data type	Description	Use
NAME	VARCHAR(128) NOT NULL	Name of the table, view, or alias.	G
CREATOR	VARCHAR(128) NOT NULL	The schema of the table, view, or alias.	G

Table 365. SYSIBM.SYSTABLES table column descriptions (continued)

Column name	Data type	Description	Use
TYPE	CHAR(1) NOT NULL	Type of object: A Alias C Clone table D Accelerator-only table G Created global temporary table H History table M Materialized query table P Table that was implicitly created for XML columns R Archive table T Table V View X Auxiliary table	G
DBNAME	VARCHAR(24) NOT NULL	For a table, or a view of tables, the name of the database that contains the table space that is named in TSNAME. For a created temporary table, an alias, or a view of a view, the value is DSNDB06.	G
TSNAME	VARCHAR(24) NOT NULL	For a table, or a view of one table, the name of the table space that contains the table. For a view of more than one table, the name of a table space that contains one of the tables. For a created temporary table, a view of a view, or an alias, it is SYSTSTAB.	G
DBID	SMALLINT NOT NULL	Internal identifier of the database; 0 if the row describes a view, alias, or created temporary table. Non-zero if the view has an INSTEAD OF trigger defined.	S
OBID	SMALLINT NOT NULL	Internal identifier of the table; 0 if the row describes a view, an alias, or a created temporary table. Non-zero if the view has an INSTEAD OF trigger defined.	S
COLCOUNT	SMALLINT NOT NULL	Number of columns in the table or view. The value is 0 if the row describes an alias.	G
EDPROC	VARCHAR(24) NOT NULL	Name of the edit procedure; blank if the row describes a view or alias or a table without an edit procedure.	G

Table 365. SYSIBM.SYSTABLES table column descriptions (continued)

Column name	Data type	Description	Use
VALPROC	VARCHAR(24) NOT NULL	Name of the validation procedure; blank if the row describes a view or alias or a table without a validation procedure.	G
CLUSTERTYPE	CHAR(1) NOT NULL	Whether RESTRICT ON DROP applies: blank No Y Yes. You cannot drop the table or any table space or database that contains the table.	G
CLUSTERRID	INTEGER NOT NULL	1 The table is a system-period temporal table with versioning, and the table is defined with the ON DELETE ADD EXTRA ROW clause. 0 All other tables.	N
CARD	INTEGER NOT NULL	Not used	N
NPAGES	INTEGER NOT NULL	Total number of pages that include rows of the table. The value is -1 if statistics have not been gathered, or the row describes a view, an alias, a created temporary table, an accelerator-only table, or an auxiliary table. This column can be updated.	S
PCTPAGES	SMALLINT NOT NULL	Percentage of active table space pages that contain rows of the table. A page is termed active if it is formatted for rows, regardless of whether it contains any. If the table space is segmented, the percentage is based on the number of active pages in the set of segments that are assigned to the table. The value is -1 if statistics have not been gathered, or the row describes a view, alias, created temporary table, an accelerator-only table, or auxiliary table. This column can be updated.	S
IBMREQD	CHAR(1) NOT NULL	A value of Y indicates that the row was provided with the Db2 product code. For all other values, see Release dependency indicators . The value in this field is not a reliable indicator of release dependencies. RELCREATED should be used instead.	G
REMARKS	VARCHAR(762) NOT NULL	A character string that is provided by the user with the COMMENT statement.	G
PARENTS	SMALLINT NOT NULL	Number of relationships in which the table is a dependent. The value is 0 if the row describes a view, an alias, a created temporary table, or a materialized query table.	G

Table 365. SYSIBM.SYSTABLES table column descriptions (continued)

Column name	Data type	Description	Use
CHILDREN	SMALLINT NOT NULL	Number of relationships in which the table is a parent. The value is 0 if the row describes a view, an alias, a created temporary table, or a materialized query table.	G
KEYCOLUMNS	SMALLINT NOT NULL	Number of columns in the primary key of the table. The value is 0 if the row describes a view, an alias, or a created temporary table.	G
RECLENGTH	SMALLINT NOT NULL	<p>For user tables, the maximum length of any record in the table. Length is $8+N+L$, where:</p> <ul style="list-style-type: none"> • The number 8 accounts for the header (6 bytes) and the ID map entry (2 bytes). • N is 10 if the table has an edit procedure, or 0 otherwise. • L is the sum of the maximum column lengths. In determining the maximum length of a column, take into account whether the column allows nulls and the data type of the column. If the column can contain nulls and is not a LOB or ROWID column, add 1 byte for a null indicator. Use 4 bytes for the length of a LOB column and 19 bytes for the length of a ROWID column. If the column has a varying-length data type (for example, VARCHAR, CLOB, or BLOB), add 2 bytes for a length indicator. For more information about column lengths, see “Data types” on page 98. <p>The value is 0 if the row describes a view, alias, or auxiliary table. For maximum row and record sizes, see the note on the maximum record size in “CREATE TABLE statement” on page 1650.</p>	G
STATUS	CHAR(1) NOT NULL	<p>Indicates the status of the table definition:</p> <p>I The definition of the table is incomplete. The TABLESTATUS column indicates the reason why the table definition is incomplete.</p> <p>R An error occurred when an attempt was made to regenerate the internal representation of the view.</p> <p>X The table has a unique constraint (primary key or unique key) and the table definition is complete.</p> <p>blank The table has no unique constraint (primary key or unique key), the table is a catalog table, or the row describes a view or alias. The definition of the table, view, or alias is complete.</p>	G
KEYOBID	SMALLINT NOT NULL	Internal Db2 identifier of the index that enforces uniqueness of the primary key of the table; 0 if not applicable.	S

Table 365. SYSIBM.SYSTABLES table column descriptions (continued)

Column name	Data type	Description	Use
LABEL	VARCHAR(90) NOT NULL	The label as given by a LABEL statement; otherwise, the value is an empty string.	G
CHECKFLAG	CHAR(1) NOT NULL WITH DEFAULT	<p>C</p> <p>The table space that contains the table is in CHECK-pending status. One of the following conditions is true:</p> <ul style="list-style-type: none"> • There are rows in the table that violate referential constraints, check constraints, or both • The table is a materialized query table that might contain inconsistent data <p>blank</p> <p>Indicates one of the following conditions:</p> <ul style="list-style-type: none"> • The table contains no rows that violate referential constraints, check constraints, or both • The table is a materialized query table that contains consistent data • The row describes a view, an alias, or a temporary table 	G
CHECKRID	CHAR(4) NOT NULL WITH DEFAULT FOR BIT DATA	A value of 'FFFFFF00' in this column indicates that the edit procedure on this table is defined without row attribute sensitivity. Any other value indicates that the edit procedure is defined with row attribute sensitivity.	G
AUDITING	CHAR(1) NOT NULL WITH DEFAULT	<p>Value of the audit option:</p> <p>A</p> <p>AUDIT ALL</p> <p>C</p> <p>AUDIT CHANGE</p> <p>blank</p> <p>AUDIT NONE, or the row describes a view, an alias, or a created temporary table.</p>	G
CREATEDBY	VARCHAR(128) NOT NULL WITH DEFAULT	Primary authorization ID of the user who created the table, view, or alias.	G
LOCATION	VARCHAR(128) NOT NULL WITH DEFAULT	Location name of the object of an alias. The value is blank for a table, a view, an alias that was not defined with a three-part object name, or a materialized query table.	G

Table 365. SYSIBM.SYSTABLES table column descriptions (continued)

Column name	Data type	Description	Use
TBCREATOR	VARCHAR(128) NOT NULL WITH DEFAULT	<ul style="list-style-type: none"> For an alias, the schema of the referenced table or view For a base table that is involved in a clone relationship, the name of the creator of the clone table For a clone table that is involved in a clone relationship, the name of the creator of the base table Otherwise, TBCREATOR is blank 	G
TBNAME	VARCHAR(128) NOT NULL WITH DEFAULT	<ul style="list-style-type: none"> For an alias, the name for the referenced table or view For a base table that is involved in a clone relationship, the name of the clone table For a clone table that is involved in a clone relationship, the name of the base table Otherwise, TBNAME is blank 	G
CREATEDTS	TIMESTAMP NOT NULL WITH DEFAULT	Time when the CREATE statement was executed for the table, view, or alias	G
ALTEREDTS	TIMESTAMP NOT NULL WITH DEFAULT	For a table, the time when the latest ALTER TABLE statement was applied. If no ALTER TABLE statement was applied, or if the row is for an alias, ALTEREDTS has the value of CREATEDTS. For a view, the time when the last ALTER VIEW REGENERATE statement was applied.	G
DATA_CAPTURE	CHAR(1) NOT NULL WITH DEFAULT	<p>Records the value of the DATA CAPTURE option for a table:</p> <p>blank No</p> <p>Y Yes</p> <p>For a created temporary table, DATA_CAPTURE is always blank.</p>	G
RBA1	CHAR(10) NOT NULL WITH DEFAULT FOR BIT DATA	The log RBA when the table was created. Otherwise, RBA1 is X'00000000000000000000', indicating that the log RBA is not known, or that the object is a view, an alias, or a created temporary table. In a data sharing environment, RBA1 is the LRSN (Log Record Sequence Number) value.	S
RBA2	CHAR(10) NOT NULL WITH DEFAULT FOR BIT DATA	The log RBA when the table was last altered. Otherwise, RBA2 is X'00000000000000000000' indicating that the log RBA is not known, or that the object is a view, an alias, or a created temporary table. RBA1 equals RBA2 if the table has not been altered. In a data sharing environment, RBA2 is the LRSN (Log Record Sequence Number) value.	S

Table 365. SYSIBM.SYSTABLES table column descriptions (continued)

Column name	Data type	Description	Use
PCTROWCOMP	SMALLINT NOT NULL WITH DEFAULT	Percentage of rows that are compressed within the total number of active rows in the table. This number includes any row in a table space that is defined with compression. The value is -1 if statistics have not been gathered, or the row describes a view, alias, created temporary table, an accelerator-only table, or auxiliary table. This column can be updated.	S
STATSTIME	TIMESTAMP NOT NULL WITH DEFAULT	If RUNSTATS or another utility with inline statistics updated the statistics, the date and time when the last utility invocation updated the statistics. The default value is '0001-01-01-00.00.00.000000'. The default value indicates that statistics were not collected. This column can be updated. For a created temporary table, the value of STATSTIME is always the default value.	G
CHECKS	SMALLINT NOT NULL WITH DEFAULT	Number of check constraints that are defined on the table. The value is 0 if either of the following conditions are true: <ul style="list-style-type: none"> The row describes a view, an alias, a created temporary table, or a materialized query table. No constraints are defined on the table. 	G
CARDF	FLOAT NOT NULL WITH DEFAULT -1	Total number of rows in the table or total number of LOBs in an auxiliary table. The value is -1 if statistics have not been gathered or the row describes a view, alias, accelerator-only table, or created temporary table. This column can be updated.	S
CHECKRID5B	CHAR(5) NOT NULL WITH DEFAULT FOR BIT DATA	RID of the first row of the table space partition that can violate referential constraints, check constraints, or both. The value of X'0000000000' indicates that any row can violate referential constraints. The value is blank if any of the following conditions are true: <ul style="list-style-type: none"> The table or partition is not in CHECK-pending status (CHECKFLAG is blank) The table space is not partitioned The table is a created temporary table 	S

Table 365. SYSIBM.SYSTABLES table column descriptions (continued)

Column name	Data type	Description	Use
ENCODING_SCHEME	CHAR(1) NOT NULL WITH DEFAULT 'E'	<p>Encoding scheme for a table, view, or the table or view that is referred to by a local alias:</p> <p>E EBCDIC. This value is 'E' even if the table contains a Unicode column.</p> <p>A ASCII</p> <p>M Multiple CCSID set or multiple encoding schemes</p> <p>U Unicode</p> <p>blank For remote aliases</p> <p>The value is 'E' for tables in non-work file databases. The value is blank for tables in work file databases that were created before Version 5 or in the default database, DSNDB04.</p> <p>This column is not applicable for objects that were created before Db2 for z/OS Version 5.</p> <p>This field contains the default encoding scheme for table columns for which a CCSID is not explicitly defined. The ENCODING_SCHEME column in SYSIBM.SYSCOLUMNS table contains the encoding schemes for columns for which a CCSID is explicitly defined.</p>	G
TABLESTATUS	VARCHAR(30) NOT NULL WITH DEFAULT	<p>Indicates the reason for an incomplete table definition:</p> <p>F The table lacks a required BUSINESS_TIME WITHOUT OVERLAPS index on a foreign key.</p> <p>L An auxiliary table or auxiliary index has not been defined for a LOB column.</p> <p>P The table lacks a primary index.</p> <p>R The table lacks a required index on a row ID.</p> <p>U The table lacks a required index on a unique key.</p> <p>V An error occurred when an attempt was made to regenerate the internal representation of the view.</p> <p>blank Definition is complete.</p>	G
NPAGESF	FLOAT(8) NOT NULL WITH DEFAULT -1	<p>Number of pages that are used by the table. The value is -1 if statistics have not been gathered or the table is an auxiliary table or accelerator-only table. This column can be updated.</p>	G

Table 365. SYSIBM.SYSTABLES table column descriptions (continued)

Column name	Data type	Description	Use
SPACEF	FLOAT(8) NOT NULL WITH DEFAULT -1	Kilobytes of DASD storage. The value is -1 if statistics have not been gathered. The value might be non-zero for an auxiliary table in the LOB table space. This column can be updated.	G
AVGROWLEN	INTEGER NOT NULL WITH DEFAULT -1	Average length of rows for the tables in the table space. If the table space is compressed, the value is the compressed row length. If the table space is not compressed, the value is the uncompressed row length. The value is -1 if statistics have not been gathered.	G
RELCREATED	CHAR(1) NOT NULL	The release of Db2 that is used to create the object. See Release dependency indicators for the values.	G
NUM_DEP_MQTS	SMALLINT NOT NULL WITH DEFAULT	Number of dependent materialized query tables. The value is zero if the row describes an alias or a created temporary table, or if no materialized query tables are defined on the table.	G
VERSION	SMALLINT NOT NULL WITH DEFAULT	The version of the data row format for this table. <ul style="list-style-type: none"> • A value of zero indicates that an alter operation that creates a new version has never occurred for this table. • A value of -1 indicates that the view has been regenerated because a column of the base table has been altered. • A value of 800 indicates that a successful CREATE VIEW or ALTER VIEW statement has occurred against this view in Version 8 or later. • A value of 900 indicates that a successful ALTER TABLE statement with a DROP COLUMN clause has occurred against this view. 	G
PARTKEYCOLNUM	SMALLINT NOT NULL WITH DEFAULT	The number of columns in the partitioning key. This value is zero for tables that do not have partitioning or use index-controlled partitioning. The value is non-zero for tables that use table-controlled partitioning.	G
SPLIT_ROWS	CHAR(1) NOT NULL WITH DEFAULT	This column is blank except for volatile tables. For volatile table, this column contains 'Y' to indicate to Db2 to use index access on this table whenever possible.	G
SECURITY_LABEL	CHAR(1) NOT NULL	This column is only meaningful if the TYPE column is a T (for table) or M (for materialized query table). The value indicates whether the table has multilevel security: <p>Blank The table does not have multilevel security.</p> <p>R The table has multilevel security with row granularity.</p>	G

Table 365. SYSIBM.SYSTABLES table column descriptions (continued)

Column name	Data type	Description	Use
OWNER	VARCHAR(128) NOT NULL WITH DEFAULT	Authorization ID of the owner of the table, view, or alias. This column is blank for tables, views, or aliases that were created before Db2 for z/OSDB2 9.	G
APPEND	CHAR(1) NOT NULL WITH DEFAULT	Indicates whether the APPEND option is specified for the table. Y The APPEND option is specified. N The APPEND option is not specified.	G
OWNERTYPE	CHAR(1) NOT NULL WITH DEFAULT	Indicates the type of owner: blank Authorization ID L Role	G
CONTROL	CHAR(1) NOT NULL WITH DEFAULT	Indicates whether access to the table is enforced by using row or column access control: blank No access control enforcement B The table is enforced by using both row and column access control C The table is enforced by using column access control R The table is enforced by using row access control	G
VERSIONING_SCHEMA	VARCHAR(128) NOT NULL WITH DEFAULT	Indicates the schema name of the history table if the table is a system-period temporal table with versioning. Indicates the schema name of the system-period temporal table if the table is a history table. Otherwise, the value is blank.	G
VERSIONING_TABLE	VARCHAR(128) NOT NULL WITH DEFAULT	Indicates the table name of the history table if the table is a system-period temporal table with versioning. Indicates the table name of system-period temporal table if the table is a history table. Otherwise, the value is blank.	G
HASHKEYCOLUMNS	SMALLINT NOT NULL WITH DEFAULT	The number of columns in the hash key of the table. The value is 0 if the row describes a view, an alias, or a created temporary table.	G

Table 365. SYSIBM.SYSTABLES table column descriptions (continued)

Column name	Data type	Description	Use
ARCHIVING_SCHEMA	VARCHAR(128) NOT NULL WITH DEFAULT	Contains a schema name as follows: <ul style="list-style-type: none"> If the table is an archive-enabled table, this column contains the schema name of the archive table. If the table is an archive table, this column contains the schema name of the archive-enabled table. If the table is not an archive-enabled table or an archive table, the value is blank. 	G
ARCHIVING_TABLE	VARCHAR(128) NOT NULL WITH DEFAULT	Contains a table name as follows: <ul style="list-style-type: none"> If the table is an archive-enabled table, this column contains the table name of the archive table. If the table is an archive table, this column contains the table name of the archive-enabled table. If the table is not an archive-enabled table or an archive table, the value is blank. 	G
STATS_FEEDBACK	CHAR (1) NOT NULL WITH DEFAULT	When a query qualifies for statistics collection based on DSNZPARM STATFDBK_SCOPE, this column controls whether statistics recommendations for this table are placed in SYSIBM.SYSSTATFEEDBACK. You can update this flag to 'Y' or 'N' to enable or disable collection for the table. The default value is 'Y'.	G
REGENERATEDTS	TIMESTAMP(12) NOT NULL	The time when the object was regenerated. The value is valid only for objects that can be regenerated. If no regeneration has occurred, this column contains the same value as the CREATEDTS column.	G
FL 502 KEYLABEL	VARCHAR(192) NOT NULL WITH DEFAULT	The key label that is specified at the table level. Otherwise, the value is an empty string.	

SYSTABLESPACE catalog table

The SYSTABLESPACE table contains one row for each table space. The schema is SYSIBM.

Column name	Data type	Description	Use
NAME	VARCHAR(24) NOT NULL	Name of the table space.	G
CREATOR	VARCHAR(128) NOT NULL	Authorization ID of the owner of the table space.	G
DBNAME	VARCHAR(24) NOT NULL	Name of the database that contains the table space.	G
DBID	SMALLINT NOT NULL	Internal identifier of the database which contains the table space.	S

Column name	Data type	Description	Use
OBID	SMALLINT NOT NULL	Internal identifier of the table space file descriptor.	S
PSID	SMALLINT NOT NULL	Internal identifier of the table space page set descriptor.	S
BPOOL	CHAR(8) NOT NULL	Name of the buffer pool used for the table space.	G
PARTITIONS	SMALLINT NOT NULL	Number of partitions of the table space; 0 if the table space is not partitioned.	G
LOCKRULE	CHAR(1) NOT NULL	Lock size of the table space: A Any L Large object (LOB) P Page R Row S Table space T Table X implicitly created XML table space	G
PGSIZE	SMALLINT NOT NULL	Size of pages in the table space in kilobytes.	G
ERASERULE	CHAR(1) NOT NULL	Whether the data sets are to be erased when dropped. The value is meaningless if the table space is a partition-by-range table space. N No erase Y Erase	G

Column name	Data type	Description	Use
STATUS	CHAR(1) NOT NULL	Availability status of the table space: A Available C Definition is incomplete because the table space does not use table-controlled partitioning and a partitioning index has not been created. P Table space is in a check pending status. S Table space is in a check pending status with the scope less than the entire table space. T Definition is incomplete because no table has been created.	G
IMPLICIT	CHAR(1) NOT NULL	Whether the table space was created implicitly: N No Y Yes	G
NTABLES	SMALLINT NOT NULL	Number of tables defined in the table space.	G
NACTIVE	INTEGER NOT NULL	Number of active pages in the table space. A page is termed active if it is formatted for rows, even if it currently contains none. The value is 0 if statistics have not been gathered. This is an updatable column.	S
	VARCHAR(24) NOT NULL	Not used	N
CLOSERULE	CHAR(1) NOT NULL	Whether the data sets are candidates for closure when the limit on the number of open data sets is reached. N No Y Yes	G
SPACE	INTEGER NOT NULL	Number of kilobytes of DASD storage allocated to the table space, as determined by the last execution of the STOSPACE utility. The value is 0 if the table space is not related to a storage group, or if STOSPACE has not been run. If the table space is partitioned, the value is the total kilobytes of DASD storage allocated to all partitions that are storage group defined.	G

Column name	Data type	Description	Use
IBMREQD	CHAR(1) NOT NULL	A value of Y indicates that the row was provided with the Db2 product code. For all other values, see Release dependency indicators . If ALTER TABLESPACE changes the DSSIZE value to 128G or 256G, this column value is changed to O, which is the release dependency indicator for Version 10. The value in this field is not a reliable indicator of release dependencies. RELCREATED should be used instead.	G
—	VARCHAR(54) NOT NULL	Internal use only.	I
—	VARCHAR(24) NOT NULL	Internal use only.	I
SEGSIZE	SMALLINT NOT NULL WITH DEFAULT	Number of pages in each segment of a segmented table space. The value is 0 if the table space is not segmented.	G
CREATEDBY	VARCHAR(128) NOT NULL WITH DEFAULT	Primary authorization ID of the user who created the table space.	G
STATSTIME	TIMESTAMP NOT NULL WITH DEFAULT	If RUNSTATS or another utility with inline statistics updated the statistics, the date and time when the last utility invocation updated the statistics. The default value is '0001-01-01-00.00.00.000000'. The default value indicates that statistics were not collected. This column can be updated.	G
LOCKMAX	INTEGER	The maximum number of locks per user to acquire for the table or table space before escalating to the next locking level. 0 Lock escalation does not occur. n <i>n</i> , where <i>n</i> > 0, is the maximum number of locks (row, page, or LOB locks for the table or table space) an application process can acquire before lock escalation occurs. -1 FL 507 Indicates that LOCKMAX SYSTEM is in effect for the table space.	G

Column name	Data type	Description	Use
TYPE	CHAR(1) NOT NULL WITH DEFAULT	The type of table space: G Partition-by-growth table space (PBG UTS) R Partition-by-range table space (PBR UTS) O LOB table space P XML table space L Partitioned (non-UTS) table space created with the LARGE option (deprecated) blank One of the following deprecated types: <ul style="list-style-type: none"> • Partitioned (non-UTS) table space • Segmented (non-UTS) table space • Simple table space 	G
CREATEDTS	TIMESTAMP NOT NULL WITH DEFAULT	Time when the CREATE statement was executed for the table space. If the table space was created in a Db2 release prior to Version 5, the value is '0001-01-01.00.00.00.000000'.	G
ALTEREDTS	TIMESTAMP NOT NULL WITH DEFAULT	Time when the most recent ALTER TABLESPACE statement was executed for the table space. If no ALTER TABLESPACE statement has been applied, ALTEREDTS has the value of CREATEDTS. If the index was created in a Db2 release prior to Version 5, the value is '0001-01-01.00.00.00.000000'.	G
ENCODING_SCHEME	CHAR(1) NOT NULL WITH DEFAULT 'E'	Default encoding scheme for the table space: E EBCDIC A ASCII U Unicode blank For table spaces in a work file database or a TEMP database (a database that was created AS TEMP, which is for declared temporary tables.) The value is 'E' for tables in non work file databases and blank for tables in work file databases created prior to Version 5 or the default database, DSNDB04.	G
SBCS_CCSID	INTEGER NOT NULL WITH DEFAULT	Default SBCS CCSID for the table space. For a table space in a work file database, a TEMP database, or a database created in a Db2 release prior to Version 5, the value is 0.	G

Column name	Data type	Description	Use
DBCS_CCSID	INTEGER NOT NULL WITH DEFAULT	Default DBCS CCSID for the table space. For a table space in a work file database, a TEMP database, or a database created in a Db2 release prior to Version 5, the value is 0.	G
MIXED_CCSID	INTEGER NOT NULL WITH DEFAULT	Default mixed CCSID for the table space. For a table space in a work file database, a TEMP database, or a database created in a Db2 release prior to Version 5, the value is 0.	G
MAXROWS	SMALLINT NOT NULL DEFAULT 255	The maximum number of rows that Db2 will place on a data page. The default value is 255. For a LOB table space, the value is 0 to indicate that the column is not applicable.	G
LOCKPART	CHAR(1) NOT NULL WITH DEFAULT	Not used.	N
LOG	CHAR(1) NOT NULL WITH DEFAULT 'Y'	Whether the changes to a table space are to be logged. N This table space has the NOT LOGGED attribute. Undo and redo logging for the table space and all indexes for tables in the table space is suppressed. Logging is also suppressed for the auxiliary indexes for all auxiliary tables associated with tables in the table space. Y This table space has the LOGGED attribute. Normal logging is associated with modifications to this table space, all indexes for tables in this table space, and all auxiliary indexes for all auxiliary tables associated with tables in the table space. X This LOB or XML table space has the NOT LOGGED attribute. Undo and redo logging for the table space is suppressed. Also, the logging attribute for this LOB or XML table space is linked to the logging attribute of the associated base table space and might not be able to be altered independently. If the logging attribute of the base table space is altered to LOGGED, the logging attribute of the LOB or XML table space will also be altered to LOGGED.	G
NACTIVEF	FLOAT NOT NULL WITH DEFAULT -1	Number of active pages in the table space. A page is termed active if it is formatted for rows, even if it currently contains none. The value is -1 if statistics have not been gathered. This is an updatable column.	S
DSSIZE	INTEGER NOT NULL WITH DEFAULT	Maximum size of a data set in kilobytes. The value might be 0 if the table space was created prior to DB2 10, but will contain the actual value after the table space is converted to a partitioned by growth table space.	G

Column name	Data type	Description	Use
OLDEST_VERSION	SMALLINT NOT NULL WITH DEFAULT	The version number of the oldest format of data in the table space and any image copies.	G
CURRENT_VERSION	SMALLINT NOT NULL WITH DEFAULT	The version number describing the newest format of data in the table space. A zero indicates that the table space has never had versioning. After the version number reaches the maximum value, the number wraps back to one.	G
AVGROWLEN	INTEGER NOT NULL WITH DEFAULT -1	Average length of rows for the tables in the table space or part. If the table space or part is compressed, the value is the compressed row length. If the table space or part is not compressed, the value is the uncompressed row length. The value is -1 if statistics have not been gathered.	G
SPACEF	FLOAT NOT NULL WITH DEFAULT	Kilobytes of DASD storage for the storage group. The value is -1 if statistics have not been gathered. This is an updatable column.	G
CREORTYPE	CHAR(1) NOT NULL WITH DEFAULT	Indicates the type of creator: blank Authorization ID L Role	G
RELCREATED	CHAR(1) NOT NULL	The release of Db2 that is used to create the object. Blank if created prior to DB2 9. See Release dependency indicators for all other values.	G
INSTANCE	SMALLINT NOT NULL WITH DEFAULT	INSTANCE indicates the data set instance number of the current base object (table and index).	G
CLONE	CHAR(1) NOT NULL WITH DEFAULT	Indicates whether the table space contains any objects that are involved in a clone relationship: Y Table space contains objects that are involved in a clone relationship N Table space does not contain any objects that are involved in a clone relationship	G
MAXPARTITIONS	SMALLINT NOT NULL WITH DEFAULT	Identifies the maximum number of partitions to which the table space can grow. 0 if the table space is not a partition-by-growth table space.	G

Column name	Data type	Description	Use
MEMBER_CLUSTER	CHAR(1) NOT NULL WITH DEFAULT	Whether MEMBER CLUSTER is specified for the table space: Y MEMBER CLUSTER is specified for the table space blank MEMBER CLUSTER is not specified for the table space	G
ORGANIZATIONTYPE	CHAR(1) NOT NULL WITH DEFAULT	Type of table space organization: blank Not known. Blank is the default. H Hash organization	G
HASHSPACE	BIGINT NOT NULL WITH DEFAULT	The amount of space, in KB, that is to be allocated to the table space or partition as hash space. For partition-by-growth table spaces, the space applies to the whole table space. For partition-by-range table spaces, the space is applicable for each partition.	G
HASHDATAPAGES	BIGINT NOT NULL WITH DEFAULT	The total number of hash data pages to preallocate for hash space. For partition-by-growth table spaces, this includes all pages in the fixed part of the table space. For partition-by-range table spaces, this is the number of pages in the fixed hash space in each partition unless it is overridden by providing hash space at the partition level. This is calculated by Db2 from the value specified with the HASH SPACE option or when the REORG utility is run with automatic estimation of space. The calculated value is used in the hash algorithm. The value is 0 for non-hash table spaces. The value is also 0 for table spaces which have been changed to use hash access but have not been reorganized.	G
PAGENUM	CHAR(1) NOT NULL WITH DEFAULT 'A'	Format of pages for the table space and indexes created on tables in the table space, indicating absolute or relative page numbering. A Indicates absolute addressing so that PAGENUM contains the embedded partition number. R Indicates relative addressing so that PAGENUM contains only the relative page number.	G

Column name	Data type	Description	Use
INSERTALG	SMALLINT NOT NULL WITH DEFAULT	<p>The insert algorithm level for tables in this table space.</p> <p>0 The insert algorithm level for tables in this table space is determined by the DEFAULT_INSERT_ALGORITHM subsystem parameter. 0 is the default value.</p> <p>1 The insert algorithm level for tables in this table space is the basic insert algorithm.</p> <p>2 The insert algorithm level for tables in this table space is the fast insert algorithm when the MEMBER CLUSTER option is specified.</p>	
PQTY	INTEGER WITH DEFAULT NULL	<p>For user-managed data sets, the value is the primary space allocation in units of 4 KB storage blocks or -1.</p> <p>PQTY is based on a value of PRIQTY in the appropriate CREATE or ALTER TABLESPACE statement. Unlike PQTY, however, PRIQTY accepts space in 1 KB units.</p> <p>A value of -1 indicates that one of the following cases is true:</p> <ul style="list-style-type: none"> • PRIQTY was not specified for a CREATE TABLESPACE statement or for any subsequent ALTER TABLESPACE statements. • -1 was the most recently specified value for PRIQTY, either on the CREATE TABLESPACE statement or a subsequent ALTER TABLESPACE statement. <p>This column contains the null value when the value is unknown for objects created prior to Db2 12.</p>	
STORATYPE	CHAR(1) WITH DEFAULT NULL	<p>Type of storage allocation:</p> <p>E Explicit (storage group not used)</p> <p>I Implicit (storage group used)</p> <p>This column is not used for rows representing catalog table spaces. Catalog data sets are managed by Db2</p> <p>This column contains the null value when the value is unknown for objects created prior to Db2 12.</p>	
STORNAME	VARCHAR(128) WITH DEFAULT NULL	<p>Name of storage group used for space allocation. Blank if storage group not used.</p> <p>This column is not used for rows representing catalog table spaces. Catalog data sets are managed by Db2</p> <p>This column contains the null value when the value is unknown for objects created prior to Db2 12.</p>	

Column name	Data type	Description	Use
VCATNAME	VARCHAR(24) WITH DEFAULT NULL	Name of integrated catalog facility catalog used for space allocation. This column is not used for rows representing catalog table spaces. Catalog data sets are managed by Db2 This column contains the null value when the value is unknown for objects created prior to Db2 12.	
FREEPAGE	SMALLINT WITH DEFAULT NULL	Number of pages loaded before a page is left as free space. This column contains the null value when the value is unknown for objects created prior to Db2 12.	
PCTFREE	SMALLINT WITH DEFAULT NULL	Percentage of each page left as free space. This column contains the null value when the value is unknown for objects created prior to Db2 12.	
COMPRESS	CHAR(1) WITH DEFAULT NULL	Indicates the COMPRESS attribute for the table space. The following values are valid for the column: Y The table space is defined to use compression. If the table space is not a LOB table space, the compression algorithm is determined by the TS_COMPRESSION_TYPE subsystem parameter. F FL 509The table space or partition is defined to use fixed-length compression H FL 509The table space or partition is defined to use Huffman compression blank The table space or partition is not defined to use compression. This column contains the null value when the value is unknown for objects created prior to Db2 12.	G

Column name	Data type	Description	Use
GBPCACHE	CHAR(1) WITH DEFAULT NULL	<p>Group buffer pool cache option specified for this table space or table space partition.</p> <p>A Changed and unchanged pages are cached in the group buffer pool.</p> <p>N No data is cached in the group buffer pool.</p> <p>S Only changed system pages, such as space map pages that do not contain actual data values, are cached in the group buffer pool.</p> <p>Blank Only changed pages are cached in the group buffer pool.</p> <p>This column contains the null value when the value is unknown for objects created prior to Db2 12.</p>	
TRACKMOD	CHAR(1) WITH DEFAULT NULL	<p>Whether to track the page modifications in the space map pages:</p> <p>N No</p> <p>blank Yes</p> <p>This column contains the null value when the value is unknown for objects created prior to Db2 12.</p> <p>This column is not applicable for LOB table spaces.</p>	
SECQTYI	INTEGER WITH DEFAULT NULL	<p>Secondary space allocation in units of 4 KB storage. For user-managed data sets, the value is the secondary space allocation in units of 4 KB blocks.</p> <p>This column contains the null value when the value is unknown for objects created prior to Db2 12.</p>	
PCTFREE_UPD	SMALLINT WITH DEFAULT NULL	<p>The percentage of free space that is reserved for updates to variable length records, as defined when the object as created or altered.</p> <p>This column contains the null value when the value is unknown for objects created prior to Db2 12.</p>	
PCTFREE_UPD_CALC	SMALLINT WITH DEFAULT NULL	<p>The percentage of free space that is reserved for updates to variable length records, calculated by Db2 or utilities.</p> <p>This column contains the null value when the value is unknown for objects created prior to Db2 12.</p>	

Column name	Data type	Description	Use
COMPRESSRATIO	SMALLINT NOT NULL WITH DEFAULT	<p>Average percentage of bytes saved by compression on each compressed data record in the table space when the table space is defined with compression. This calculation includes overhead bytes for each row. The value is based on an average row length and varies depending on the actual length of the data rows.</p> <p>For example, a value of 25 indicates that the average compressed record size is approximately 75% the size of the uncompressed record.</p> <p>The value is -1 or 0 in the following cases:</p> <p>-1 This value has not been collected</p> <p>0 No compression exists or the average compressed record length is the same as or longer than the uncompressed record length.</p>	G
FL 502 KEYLABEL	VARCHAR(192) NOT NULL WITH DEFAULT	The key label that is specified at the table level. Otherwise, the value is an empty string.	

SYSTABLESPACESTATS catalog table

The SYSTABLESPACESTATS table contains real time statistics for table spaces. The schema is SYSIBM.

Rows in this table can be inserted, updated, and deleted. However, the following columns cannot be updated: SYS_START, SYS_END, and TRANS_START.

Important: Use care when issuing SQL statements or using tools to update statistics values in catalog tables. If such updates introduce invalid data, unpredictable results can occur, including abends for RUNSTATS and other utilities. If such problems occur, you can run the RUNSTATS utility and collect statistics at the table space level to resolve the problems, in most cases.

In data sharing environments, the values in SYSIBM.SYSTABLESPACESTATS can be negative for short periods of time for certain situations.

Column name	Data type	Description	Use
UPDATESTATSTIME	TIMESTAMP NOT NULL WITH DEFAULT	The timestamp that the row in the SYSTABLESPACESTATS table is inserted or updated.	G
NACTIVE	INTEGER	The number of active pages in the table space or partition.	G
NPAGES	INTEGER	<p>The number of distinct pages with active rows in the partition or table space. This is an updatable column.</p> <p>This column can be used to calculate an estimate of the size of LOB data in a table space. To produce an estimate, use the following formula:</p>	G
		$\text{value of NPAGES} * \text{page size} = \text{approximate size of LOB data}$	

Column name	Data type	Description	Use
EXTENTS	SMALLINT	The number of extents in the table space. For multi-piece table spaces, this value is the number of extents for the last data set. For a data set that is striped across multiple volumes, the value is the number of logical extents. A null value indicates the number of extents is unknown.	G
LOADRLASTTIME	TIMESTAMP	The timestamp that the LOAD REPLACE utility was last run on the table space or partition. A null value indicates that the LOAD REPLACE utility has never been run on the table space or partition or that the timestamp is unknown.	G
REORGLASTTIME	TIMESTAMP	The timestamp the REORG utility was last run on the table space or partition, or when the REORG utility has not been run, the time when the table space or partition was created. A null value indicates that the timestamp is unknown.	G
REORGINSERTS	INTEGER	The number of rows or LOBs that have been inserted into the table space or partition or loaded into the table space or partition using the LOAD utility specified without the REPLACE option since the last time the REORG or LOAD REPLACE utilities were run, or since the object was created. A null value indicates that the number of inserted rows or LOBs is unknown. If the value is 2147483647, the actual number of inserted rows or LOBs might be greater than this value.	G
REORGDELETES	INTEGER	The number of rows or LOBs that have been deleted from the table space or partition since the last time the REORG or LOAD REPLACE utilities were run, or since the object was created. A null value indicates that the number of deleted rows or LOBs is unknown. If the value is 2147483647, the actual number of deleted rows or LOBs might be greater than this value.	G
REORGUPDATES	INTEGER	The number of rows that have been updated in the table space or partition since the last time the REORG or LOAD REPLACE utilities were run, or since the object was created. A null value indicates that the number of updated rows is unknown. If the value is 2147483647, the actual number of updated rows or LOBs might be greater than this value.	G

Column name	Data type	Description	Use
REORGUNCLUSTINS	INTEGER	<p>The number of rows that were inserted that are not well-clustered with respect to the clustering index since the last REORG or LOAD REPLACE, or since the object was created. A record is well-clustered if the record is inserted into a page that is within 16 pages of the ideal candidate page. The clustering index determines the ideal candidate page.</p> <p>A null value indicates that the number of pages that are not well clustered is unknown.</p> <p>For a table space that has the MEMBER CLUSTER attribute, the clustering index is not used to identify the ideal candidate page. Therefore, this value is not updated.</p>	G
REORGDISORGLOB	INTEGER	<p>The number of LOBs that were inserted that are not perfectly chunked since the last REORG or LOAD REPLACE, or since the object was created. A LOB is perfectly chunked if the allocated pages are in the minimum number of chunks.</p> <p>A null value indicates that the number of not perfectly chunked LOBs is unknown.</p>	G
REORGMASDELETE	INTEGER	<p>The number of mass deletes from a segmented or LOB table space, or the number of dropped tables from a segmented table space since the last time the REORG or LOAD REPLACE utilities were run, or since the object was created.</p> <p>A null value indicates that the number of mass deletes is unknown.</p>	G
REORGNEARINDREF	INTEGER	<p>The number of overflow rows that are created and relocated near the pointer record since the last time the REORG and LOAD REPLACE utilities were run, or since the object was created. For non-segmented table spaces, a page is near the present page if the two page numbers differ by 16 or less. For segmented table spaces, a page is near the present page if the two page numbers differ by SEGSIZE*2 or less.</p> <p>A null value indicates that the number of overflow rows that are near the pointer record is unknown.</p>	G

Column name	Data type	Description	Use
REORGFARINDREF	INTEGER	<p>The number of overflow rows that are created and relocated far from the pointer record since the last time the REORG and LOAD REPLACE utilities were run, or since the object was created. For non-segmented table spaces, a page is far from the present page if the two page numbers differ by more than 16. For segmented table spaces, a page is far from the present page if the two page numbers differ by at least (SEGSIZE*2)+1.</p> <p>A null value indicates that the number of overflow rows that are near the pointer record is unknown.</p>	G
STATSLASTTIME	TIMESTAMP	<p>The timestamp of the last time that the RUNSTATS utility is run on the table space or partition, or the time that table space or partition was created.</p>	G
STATSINSERTS	INTEGER	<p>The number of rows or LOBs that have been inserted into the table space or partition or loaded into the table space or partition using the LOAD utility specified without the REPLACE option since the last time that the RUNSTATS utility was run, or since the object was created.</p> <p>A null value indicates that the number of inserted rows or LOBs is unknown.</p> <p>If the value is 2147483647, the actual number of inserted rows or LOBs might be greater than this value.</p>	G
STATSDELETES	INTEGER	<p>The number of rows or LOBs that have been deleted from the table space or partition since the last time that the RUNSTATS utility was run, or since the object was created.</p> <p>A null value indicates that the number of deleted rows or LOBs is unknown.</p> <p>If the value is 2147483647, the actual number of deleted rows or LOBs might be greater than this value.</p>	G
STATSUPDATES	INTEGER	<p>The number of rows that have been updated in the table space or partition since the last time that the RUNSTATS utility was run, or since the object was created.</p> <p>A null value indicates that the number of updated rows is unknown.</p> <p>If the value is 2147483647, the actual number of updated rows or LOBs might be greater than this value.</p>	G

Column name	Data type	Description	Use
STATSMASDELETE	INTEGER	<p>The number of mass deletes from a segmented or LOB table space, or the number of tables that are dropped from a segmented table space, since the last time the RUNSTATS utility was run, or since the object was created.</p> <p>A null value indicates that the number of mass deletes is unknown.</p>	G
COPYLASTTIME	TIMESTAMP	<p>The timestamp of the last full or incremental image copy of the table space or partition.</p> <p>A null value indicates that the COPY utility has never been run on the table space or partition. A null value can also indicate that the timestamp of the last image copy is unknown.</p>	G
COPYUPDATEDPAGES	INTEGER	<p>If the COPY utility was run with a SHRLEVEL value other than CHANGE, this value is the number of distinct pages that have been updated since the last time that the COPY utility was run.</p> <p>If the COPY utility was run with SHRLEVEL CHANGE, this value is the total number of distinct pages that were updated during the time that the last COPY utility was run, and since the last time that the COPY utility was run.</p> <p>A null value indicates that the number of updated pages is unknown.</p>	G
COPYCHANGES	INTEGER	<p>If the COPY utility was run with a SHRLEVEL value other than CHANGE, this value is the number of insert, update, and delete operations, or the number of rows loaded, since the last time that the COPY utility was run.</p> <p>If the COPY utility was run with SHRLEVEL CHANGE, this value is the total number of insert, update, and delete operations, or the number of rows loaded, during the time that the last COPY utility was run, and since the last time that the COPY utility was run.</p> <p>This value does not include operations that result in no change to the data, such as an update that sets the value of a column to its existing value.</p> <p>A null value indicates that the number of insert, update, and delete operations or the number of rows loaded is unknown.</p>	G
COPYUPDATELRSN	CHAR(10) FOR BIT DATA	<p>The LRSN or RBA of the first update that occurs after the last time the COPY utility was run.</p> <p>A null value indicates that the LRSN or RBA is unknown.</p>	G

Column name	Data type	Description	Use
COPYUPDATETIME	TIMESTAMP	<p>If the COPY utility was run with a SHRLEVEL value other than CHANGE, this value is the timestamp of the first update that occurred after the last time that the COPY utility was run.</p> <p>If the COPY utility was run with SHRLEVEL CHANGE, this value is the timestamp of the first update that occurred during the time that the last COPY utility was run, or since the last time that the COPY utility was run.</p> <p>A null value indicates that the timestamp is unknown.</p>	G
IBMREQD	CHAR(1) NOT NULL	<p>A value of Y indicates that the row was provided with the Db2 product code. For all other values, see Release dependency indicators.</p> <p>The value in this field is not a reliable indicator of release dependencies.</p>	G
DBID	SMALLINT NOT NULL	The internal identifier of the database. This column is used to map a DBID to its statistics.	G
PSID	SMALLINT NOT NULL	The internal identifier of the table space page set descriptor. This column is used to map a PSID to its statistics.	G
PARTITION	SMALLINT NOT NULL	The data set number within the table space. This column is used to map a data set number in a table space to its statistics. For partitioned table spaces, this value corresponds to the partition number for a single partition. For non-partitioned table spaces, this value is 0.	G
INSTANCE	SMALLINT NOT NULL WITH DEFAULT 1	Indicates if the object is associated with data set instance 1 or 2. This is an updatable column.	G
SPACE	BIGINT	The amount of space, in KB, that is allocated to the table space or partition. For multi-piece, linear page sets, this value is the amount of space in all data sets. A null value indicates the amount of space is unknown.	G
TOTALROWS	BIGINT	<p>The number of rows or LOBs that are in the table space or partition, calculated from the in-memory counters for inserts and deletes.</p> <p>For XML, this column contains the number of physical rows in the table space or partition. Each XML document might have more than one physical record in a table space or partition.</p>	G
DATASIZE	BIGINT	The total number of bytes that row data occupy. For LOB table spaces this column is always 0. This is an updatable column.	G

Column name	Data type	Description	Use
UNCOMPRESSED DATASIZE	BIGINT	This column is not used. The value is always set to 0.	G
DBNAME	VARCHAR(24) NOT NULL	The name of the database. This column is used to map a database to its statistics.	G
NAME	VARCHAR(24) NOT NULL	The name of the table space. This column is used to map a table space to its statistics.	G
REORGSCANACCESS	BIGINT	The number of times data is accessed for SELECT, FETCH, searched UPDATE, or searched DELETE since the last CREATE, LOAD REPLACE or REORG, or since the object was created. A null value indicates that the number of times data is accessed is unknown.	G
REORGHASHACCESS	BIGINT	The number of times data is accessed using hash access for SELECT, FETCH, searched UPDATE, searched DELETE, or used to enforce referential integrity constraints since the last CREATE, LOAD REPLACE or REORG, or since the object was created. A null value indicates that the number of times data is accessed is unknown.	G
HASHLASTUSED	DATE	The date when hash access was last used for SELECT, FETCH, searched UPDATE, searched DELETE, or used to enforce referential integrity constraints.	G
REORGCLUSTERSENS	BIGINT	The number of times that data has been read by SQL statements that are sensitive to the clustering sequence of the data since the last REORG or LOAD REPLACE, or since the object was created. For a table space that has the MEMBER CLUSTER attribute, when records are inserted, the clustering index is not used. Therefore, this value is not updated.	G
DRIVETYPE	CHAR(3) NOT NULL WITH DEFAULT	The drive type on which the table space or table space partition data set is defined. HDD Hard Disk Drive SSD Solid State Drive For multi-volume data sets, the drive type is set to SSD if any volume is SSD. For multi-piece linear page sets, the drive type of the first data set is used. This is an updatable column.	G

Column name	Data type	Description	Use
LPFACILITY	CHAR(1)	<p>Whether the disk control unit has the high performance list prefetch facility.</p> <p>N No</p> <p>Y Yes</p> <p>A NULL value indicates that it is unknown whether the disk control unit has the high performance list prefetch facility. This is an updatable column.</p>	G
	BIGINT	Reserved for future IBM use.	R
UPDATESIZE	BIGINT	The net number of bytes that were added or removed by UPDATE operations since the object was created, or since the last REORG or LOAD REPLACE operation. Valid values can be positive or negative.	G
LASTDATACHANGE	TIMESTAMP	<p>The timestamp when one of the following events occurred:</p> <ul style="list-style-type: none"> The last utility operation affected the data in a table space or partition, and Db2 did not log the changes. <p>Some utility operations that update this column are REORG with the DISCARD option, REORG with the REBALANCE option, or a REORG operation that moves data in a partition-by-growth table space across partitions. A REORG operation that reorders data within the same partition does not result in an update of this column.</p> <ul style="list-style-type: none"> An SQL statement affected the data in a table space or partition. <p>SQL statements that update this column are INSERT, UPDATE, DELETE, MERGE, and TRUNCATE.</p> <p>The timestamp reflects the time at which the real-time statistics table was updated, and not the time at which the data in the table space or partition was modified.</p> <p>This value can also be updated when an -ACCESS DATABASE command is issued with the MODE(STATS) keyword, but an object in UTRO or UTRW state prevents the externalization of real-time statistics. In such cases, Db2 preserves the in-memory statistics until next possible externalization cycle.</p>	G

Column name	Data type	Description	Use
GETPAGES	BIGINT	The number of getpage requests for the table space since the object was created, or since the last REORG or LOAD REPLACE was run. The value wraps if it exceeds the largest possible BIGINT value, 9223372036854775807.	G
SYS_START	TIMESTAMP(12) NOT NULL GENERATED ALWAYS AS ROW BEGIN	The row-begin column of the SYSTEM_TIME period, for system-period data versioning.	G
SYS_END	TIMESTAMP(12) NOT NULL GENERATED ALWAYS AS ROW END	The row-end column of the SYSTEM_TIME period, for system-period data versioning.	G
TRANS_START	TIMESTAMP(12) NOT NULL GENERATED ALWAYS AS TRANSACTION START ID	The transaction-start-ID column, for system-period data versioning.	G

Related concepts

How Db2 maintains in-memory statistics in data sharing (Db2 Data Sharing Planning and Administration)

Related tasks

[Setting up your system for real-time statistics \(Db2 Performance\)](#)

SYSTABLES_HIST catalog table

The SYSTABLES_HIST table contains rows from the SYSTABLES table. The schema is SYSIBM.

Rows are added or changed in this table when RUNSTATS collects history statistics. Rows in this table can also be inserted, updated, and deleted.

Table 366. SYSIBM.SYSTABLES_HIST table column descriptions

Column name	Data type	Description	Use
NAME	VARCHAR(128) NOT NULL	Name of the table, view, or alias.	G
CREATOR	VARCHAR(128) NOT NULL	The schema of the table, view, or alias.	G
DBNAME	VARCHAR(24) NOT NULL	For a table, or a view of tables, the name of the database that contains the table space named in TSNAME. For a temporary table, an alias, or a view of a view, the value is DSNDB06.	G

Table 366. SYSIBM.SYSTABLES_HIST table column descriptions (continued)

Column name	Data type	Description	Use
TSNAME	VARCHAR(24) NOT NULL	For a table, or a view of one table, the name of the table space that contains the table. For a view of more than one table, the name of a table space that contains one of the tables. For a temporary table, a view of a view, or an alias, it is SYSTSTAB.	G
COLCOUNT	SMALLINT NOT NULL	Number of columns in the table or view. The value is 0 if the row describes an alias.	G
PCTPAGES	SMALLINT NOT NULL WITH DEFAULT -1	Percentage of active table space pages that contain rows of the table. A page is termed active if it is formatted for rows, regardless of whether it contains any. If the table space is segmented, the percentage is based on the number of active pages in the set of segments assigned to the table. The value is -1 if statistics have not been gathered, or the row describes a view, alias, temporary table, accelerator-only table, or auxiliary table.	S
PCTROWCOMP	SMALLINT NOT NULL WITH DEFAULT -1	Percentage of rows compressed within the total number of active rows in the table. This includes any row in a table space that is defined with compression. The value is -1 if statistics have not been gathered, or the row describes a view, alias, temporary table, accelerator-only table, or auxiliary table.	G
STATSTIME	TIMESTAMP NOT NULL	If RUNSTATS or another utility with inline statistics updated the statistics, the date and time when the last utility invocation updated the statistics. The default value is '0001-01-01-00.00.00.000000'. The default value indicates that statistics were not collected. This column can be updated. For a temporary table, the value of STATSTIME is always the default value.	G
CARDF	FLOAT(8) NOT NULL WITH DEFAULT -1	Total number of rows in the table or total number of LOBs in an auxiliary table. The value is -1 if statistics have not been gathered or the row describes a view, alias, accelerator-only table, or temporary table.	S
NPAGESF	FLOAT(8) NOT NULL WITH DEFAULT -1	Total number of pages on which rows of the partition appear. The value is -1 if statistics have not been gathered.	S
AVGROWLEN	INTEGER NOT NULL WITH DEFAULT -1	Average row length of the table specified in the table space. The value is -1 if statistics have not been gathered.	G
SPACEF	FLOAT(8) NOT NULL WITH DEFAULT -1	Kilobytes of DASD storage. The value is -1 if statistics have not been gathered. This is an updatable column.	G

Table 366. SYSIBM.SYSTABLES_HIST table column descriptions (continued)

Column name	Data type	Description	Use
IBMREQD	CHAR(1) NOT NULL WITH DEFAULT 'N'	A value of Y indicates that the row was provided with the Db2 product code. For all other values, see Release dependency indicators . The value in this field is not a reliable indicator of release dependencies.	G

SYSTABLES_PROFILES catalog table

The SYSTABLES_PROFILES table contains one row for each profile that is associated with a table in SYSIBM.SYSTABLES. The schema is SYSIBM.

Rows in this table can be inserted, updated, and deleted.

Table 367. SYSIBM.SYSTABLES_PROFILES table column descriptions

Column name	Data type	Description	Use
SCHEMA	VARCHAR(128) NOT NULL	The schema (qualifier) for the table.	G
TBNAME	VARCHAR(128) NOT NULL	The table name.	G
PROFILE_TYPE	VARCHAR(32) NOT NULL	The type of profile. Allowed values are 'RUNSTATS'.	G
—	VARCHAR(32)	Internal use only.	I
PROFILE_TEXT	CLOB(1M)	The text of the profile.	G
ROWID	ROWID NOT NULL GENERATED ALWAYS	The ROWID value for the LOB column of this table.	G
PROFILE_UPDATE	TIMESTAMP NOT NULL	The last time the profile was updated, or the timestamp for when the profile was inserted into the table.	G
—	TIMESTAMP	Internal use only.	I

Related concepts

[Statistics profiles \(Db2 Performance\)](#)

Related tasks

[Automating statistics maintenance \(Db2 Performance\)](#)

SYSTABLES_PROFILE_TEXT catalog table

The SYSTABLES_PROFILE_TEXT table is an auxiliary table for the PROFILE_TEXT column of the SYSIBM.SYSTABLES_PROFILES table and is required to hold LOB data. The schema is SYSIBM.

Table 368. SYSIBM.SYSTABLES_PROFILE_TEXT table column descriptions

Column name	Data type	Description	Use
PROFILE_TEXT	CLOB(2M) NOT NULL WITH DEFAULT	The complete text for the profile that the row represents.	G

SYSTABSTATS catalog table

The SYSTABSTATS table contains one row for each partition of a partitioned table space. The schema is SYSIBM.

Rows in this table can be inserted, updated, and deleted.

Important: Use care when issuing SQL statements or using tools to update statistics values in catalog tables. If such updates introduce invalid data, unpredictable results can occur, including abends for RUNSTATS and other utilities. If such problems occur, you can run the RUNSTATS utility and collect statistics at the table space level to resolve the problems, in most cases.

Table 369. SYSIBM.SYSTABSTATS table column descriptions

Column name	Data type	Description	Use
CARD	INTEGER NOT NULL	Total number of rows in the partition.	S
NPAGES	INTEGER NOT NULL	Total number of pages on which rows of the partition appear.	S
PCTPAGES	SMALLINT NOT NULL	Percentage of total active pages in the partition that contain rows of the table.	S
NACTIVE	INTEGER NOT NULL	Number of active pages in the partition.	S
PCTROWCOMP	SMALLINT NOT NULL	Percentage of rows compressed within the total number of active rows in the partition. This includes any row in a table space that is defined with compression.	S
STATSTIME	TIMESTAMP NOT NULL	If RUNSTATS or another utility with inline statistics updated the statistics, the date and time when the last utility invocation updated the statistics. The default value is '0001-01-01-00.00.00.000000'. The default value indicates that statistics were not collected. This column can be updated.	G
IBMREQD	CHAR(1) NOT NULL	A value of Y indicates that the row was provided with the Db2 product code. For all other values, see Release dependency indicators . The value in this field is not a reliable indicator of release dependencies.	G

Table 369. SYSIBM.SYSTABSTATS table column descriptions (continued)

Column name	Data type	Description	Use
DBNAME	VARCHAR(24) NOT NULL	Database that contains the table space named in TSNAME.	G
TSNAME	VARCHAR(24) NOT NULL	Table space that contains the table.	G
PARTITION	SMALLINT NOT NULL	Partition number of the table space that contains the table.	G
OWNER	VARCHAR(128) NOT NULL	The schema of the table.	G
NAME	VARCHAR(128) NOT NULL	Name of the table.	G
CARDF	FLOAT NOT NULL WITH DEFAULT -1	Total number of rows in the partition.	S

SYSTABSTATS_HIST catalog table

The SYSTABSTATS_HIST table contains rows from the SYSTABSTATS table.

Rows are added or changed in this table when RUNSTATS collects history statistics. Rows in this table can also be inserted, updated, and deleted.

Table 370. SYSIBM.SYSTABSTATS_HIST table column descriptions

Column name	Data type	Description	Use
NPAGES	INTEGER NOT NULL	Total number of pages on which rows of the partition appear.	S
STATSTIME	TIMESTAMP NOT NULL	If RUNSTATS or another utility with inline statistics updated the statistics, the date and time when the last utility invocation updated the statistics. The default value is '0001-01-01-00.00.00.000000'. The default value indicates that statistics were not collected. This column can be updated.	G
DBNAME	VARCHAR(24) NOT NULL	Database that contains the table space named in TSNAME.	G
TSNAME	VARCHAR(24) NOT NULL	Table space that contains the table.	G
PARTITION	SMALLINT NOT NULL	Partition number of the table space that contains the table.	G

Table 370. SYSIBM.SYSTABSTATS_HIST table column descriptions (continued)

Column name	Data type	Description	Use
OWNER	VARCHAR(128) NOT NULL	The schema of the table.	G
NAME	VARCHAR(128) NOT NULL	Name of the table.	G
CARDF	FLOAT(8) NOT NULL WITH DEFAULT -1	Total number of rows in the partition. The value is -1 if statistics have not been gathered.	S
IBMREQD	CHAR(1) NOT NULL WITH DEFAULT 'N'	A value of Y indicates that the row was provided with the Db2 product code. For all other values, see Release dependency indicators . The value in this field is not a reliable indicator of release dependencies.	G

SYSTRIGGERS catalog table

The SYSTRIGGERS table contains one row for each trigger. The schema is SYSIBM.

Column name	Data type	Description	Use
NAME	VARCHAR(128) NOT NULL	Name of the trigger and trigger package.	G
SCHEMA	VARCHAR(128) NOT NULL	Schema of the trigger. This implicit or explicit qualifier for the trigger name is also used for the collection ID of the trigger package.	G
SEQNO	SMALLINT NOT NULL	Not used.	N
DBID	SMALLINT NOT NULL	Internal identifier of the database for the trigger.	G
OBID	SMALLINT NOT NULL	Internal identifier of the trigger.	G
OWNER	VARCHAR(128) NOT NULL	Owner of the trigger.	G
CREATEDBY	VARCHAR(128) NOT NULL	Primary authorization ID of the user who created the trigger.	G
TBNAME	VARCHAR(128) NOT NULL	Name of the table or view.	G
TBOWNER	VARCHAR(128) NOT NULL	Qualifier of the name of the table or view to which this trigger applies.	G

Column name	Data type	Description	Use
TRIGTIME	CHAR(1) NOT NULL	Time when triggered actions are applied to the base table, relative to the event that activated the trigger: A Trigger is applied after the event. B Trigger is applied before the event. I Trigger is applied instead of the event	G
TRIGEVENT	CHAR(1) NOT NULL	Operation that activates the trigger: I Insert D Delete U Update	G
GRANULARITY	CHAR(1) NOT NULL	Trigger is executed once per: S Statement R Row	G
CREATEDTS	TIMESTAMP NOT NULL	Time when the trigger was created or recreated.	G
IBMREQD	CHAR(1) NOT NULL	A value of Y indicates that the row was provided with the Db2 product code. For all other values, see Release dependency indicators . The value in this field is not a reliable indicator of release dependencies. RELCREATED should be used instead.	G
TEXT	VARCHAR(6000) NOT NULL	Not used.	N
REMARKS	VARCHAR(762) NOT NULL	A character string provided by the user with the COMMENT statement.	G
TRIGNAME	VARCHAR(128) NOT NULL	Not used.	G
OWNERTYPE	CHAR(1) NOT NULL WITH DEFAULT	Indicates the type of creator: blank Authorization ID L Role	G

Column name	Data type	Description	Use
ENVID	INTEGER NOT NULL WITH DEFAULT	Internal environment identifier.	G
RELCREATED	CHAR(1) NOT NULL	The release of Db2 that is used to create the object. Blank if created prior to Version 9. See Release dependency indicators for all other values.	G
SECURE	CHAR(1) NOT NULL WITH DEFAULT 'N'	Indicates if the trigger is secured: N The trigger is not secured Y The trigger is secured	G
ALTEREDTS	TIMESTAMP NOT NULL	Indicates when the trigger was last changed.	G
ROWID	ROWID NULL GENERATED ALWAYS	ROWID column, created for the lob columns in this table.	G
SQLPL	CHAR(1) NOT NULL WITH DEFAULT	Indicates whether the trigger supports SQL PL: Y Advanced trigger that supports SQL PL. blank Basic trigger that does not support SQL PL.	G
DEBUG_MODE	CHAR(1) NOT NULL WITH DEFAULT	Indicates whether the trigger is enabled for debugging: 1 This trigger is enabled for debugging, and can be debugged in a client debug session using the Db2 Unified Debugger. 0 This trigger is not enabled for debugging. N This trigger can never be enabled for debugging. blank This trigger is a basic trigger that cannot be debugged.	G
ASUTIME	INTEGER NOT NULL	Number of CPU service units that are allowed for a single invocation of this trigger. If ASUTIME is zero, the number of CPU service units is unlimited. If the trigger consumes more CPU service units than the ASUTIME value allows, Db2 cancels the trigger.	G
WLM_ENVIRONMENT	VARCHAR(96) NOT NULL	The WLM ENVIRONMENT FOR DEBUG MODE value in the trigger definition. This value is the name of the WLM environment that is used when a trigger is debugged. If this value is blank, the trigger cannot be debugged.	G

Column name	Data type	Description	Use
STATEMENT	CLOB(2M) NOT NULL WITH DEFAULT	The text of the entire CREATE TRIGGER statement that was used to create the object.	G
VERSION	VARCHAR(122) NOT NULL	The version identifier for a trigger. A zero length string for a basic trigger.	G
ORIGINAL_CONTOK	CHAR(8) NOT NULL FOR BIT DATA	The consistency token for the trigger. The column is set to X'20' if the value of VERSION is a zero length string.	G
REGENERATETS	TIMESTAMP NOT NULL	The time when the object was regenerated. The value is valid only for objects that can be regenerated. If no regeneration has occurred, this column contains the same value as the CREATEDTS column.	G
ACTIVE	CHAR(1) NOT NULL	Identifies the active version of the trigger: Y The version is the active version. N The version is not the active version. blank The value of VERSION is a zero length string.	G
WRAPPED	CHAR(1) NOT NULL	'Y' The trigger text is obfuscated. blank The trigger text is not obfuscated.	G

SYSTRIGGERS_STMT catalog table

The SYSTRIGGERS_STMT table is an auxiliary table for the STATEMENT column of the SYSTRIGGERS table and contains LOB data. The schema is SYSIBM.

Table 371. SYSIBM.SYSTRIGGERS_STMT table column descriptions

Column name	Data type	Description	Use
STATEMENT	CLOB(2M) NOT NULL WITH DEFAULT	The text of the entire CREATE TRIGGER statement that was used to create the object.	G

SYSUSERAUTH catalog table

The SYSUSERAUTH table records the system privileges that are held by users. The schema is SYSIBM.

Column name	Data type	Description	Use
GRANTOR	VARCHAR(128) NOT NULL	Authorization ID of the user who granted the privileges.	G

Column name	Data type	Description	Use
GRANTEE	VARCHAR(128) NOT NULL	Authorization ID of the user that holds the privilege. Could also be PUBLIC for a grant to PUBLIC.	G
—	CHAR(12) NOT NULL	Internal use only.	I
DATEGRANTED	CHAR(6) NOT NULL	Not used.	N
TIMEGRANTED	CHAR(8) NOT NULL	Not used.	N
GRANTEETYPE	CHAR(1) NOT NULL	Not used.	N
AUTHHOWGOT	CHAR(1) NOT NULL WITH DEFAULT	<p>Authorization level of the user from whom the privileges were received. This authorization level is not necessarily the highest authorization level of the grantor.</p> <p>blank Not applicable. AUTHHOWGOT is also blank when the privilege that is held is BINDAGENT.</p> <p>C DBCTRL</p> <p>D DBADM</p> <p>E SECADM</p> <p>G ACCESSCTRL</p> <p>K SQLADM</p> <p>L SYSCTRL</p> <p>M DBMAINT</p> <p>O SYSOPR</p> <p>S SYSADM</p>	G
ALTERBPAUTH	CHAR(1) NOT NULL	Not used.	N

Column name	Data type	Description	Use
BINDADDAUTH	CHAR(1) NOT NULL	Whether the GRANTEE can use the BIND subcommand with the ADD option: blank Privilege is not held G Privilege is held with the GRANT option Y Privilege is held without the GRANT option	G
BSDSAUTH	CHAR(1) NOT NULL	Whether the GRANTEE can issue the RECOVER BSDS command: blank Privilege is not held G Privilege is held with the GRANT option Y Privilege is held without the GRANT option	G
CREATEDBAAUTH	CHAR(1) NOT NULL	Whether the GRANTEE can create databases and automatically receive DBADM authority over the new databases: blank Privilege is not held G Privilege is held with the GRANT option Y Privilege is held without the GRANT option	G
CREATEDBCAUTH	CHAR(1) NOT NULL	Whether the GRANTEE can execute the CREATE DATABASE statement to create new databases and automatically receive DBCTRL authority over the new databases: blank Privilege is not held G Privilege is held with the GRANT option Y Privilege is held without the GRANT option	G
CREATESGAUTH	CHAR(1) NOT NULL	Whether the GRANTEE can execute the CREATE STOGROUP statement to create new storage groups: blank Privilege is not held G Privilege is held with the GRANT option Y Privilege is held without the GRANT option	G

Column name	Data type	Description	Use
DISPLAYAUTH	CHAR(1) NOT NULL	Whether the GRANTEE can use the DISPLAY commands: blank Privilege is not held G Privilege is held with the GRANT option Y Privilege is held without the GRANT option	G
RECOVERAUTH	CHAR(1) NOT NULL	Whether the GRANTEE can use the RECOVER INDOUBT command: blank Privilege is not held G Privilege is held with the GRANT option Y Privilege is held without the GRANT option	G
STOPALLAUTH	CHAR(1) NOT NULL	Whether the GRANTEE can use the STOP command: blank Privilege is not held G Privilege is held with the GRANT option Y Privilege is held without the GRANT option	G
STOSPACEAUTH	CHAR(1) NOT NULL	Whether the GRANTEE can use the STOSPACE utility: blank Privilege is not held G Privilege is held with the GRANT option Y Privilege is held without the GRANT option	G
SYSADMAUTH	CHAR(1) NOT NULL	Whether the GRANTEE has system administration authority: blank Privilege is not held G Privilege was granted with the GRANT option Y Privilege was granted without the GRANT option GRANTEE has the privilege with the GRANT option for a value of either Y or G.	G

Column name	Data type	Description	Use
SYSOPRAUTH	CHAR(1) NOT NULL	Whether the GRANTEE has system operator authority: blank Privilege is not held G Privilege is held with the GRANT option Y Privilege is held without the GRANT option	G
TRACEAUTH	CHAR(1) NOT NULL	Whether the GRANTEE can issue the START TRACE and STOP TRACE commands: blank Privilege is not held G Privilege is held with the GRANT option Y Privilege is held without the GRANT option	G
IBMREQD	CHAR(1) NOT NULL	A value of Y indicates that the row was provided with the Db2 product code. For all other values, see Release dependency indicators . The value in this field is not a reliable indicator of release dependencies.	G
MON1AUTH	CHAR(1) NOT NULL WITH DEFAULT	Whether the GRANTEE can obtain IFC serviceability data: blank Privilege is not held G Privilege is held with the GRANT option Y Privilege is held without the GRANT option	G
MON2AUTH	CHAR(1) NOT NULL WITH DEFAULT	Whether the GRANTEE can obtain IFC data: blank Privilege is not held G Privilege is held with the GRANT option Y Privilege is held without the GRANT option	G
CREATEALIASAUTH	CHAR(1) NOT NULL WITH DEFAULT	Whether the GRANTEE can execute the CREATE ALIAS statement: blank Privilege is not held G Privilege held with the GRANT option Y Privilege held without the GRANT option	G

Column name	Data type	Description	Use
SYSCTRLAUTH	CHAR(1) NOT NULL WITH DEFAULT	Whether the GRANTEE has SYSCTRL authority: blank Privilege is not held G Privilege is held with the GRANT option Y Privilege is held without the GRANT option GRANTEE has the privilege with the GRANT option for a value of either Y or G.	G
BINDAGENTAUTH	CHAR(1) NOT NULL WITH DEFAULT	Whether the GRANTEE has BINDAGENT privilege: blank Privilege is not held G Privilege is held with the GRANT option Y Privilege is held without the GRANT option	G
ARCHIVEAUTH	CHAR(1) NOT NULL WITH DEFAULT	Whether the GRANTEE is privileged to use the ARCHIVE LOG command: blank Privilege is not held G Privilege is held with the GRANT option Y Privilege is held without the GRANT option	G
CAPTURE1AUTH	CHAR(1) NOT NULL WITH DEFAULT	Not used.	N
CAPTURE2AUTH	CHAR(1) NOT NULL WITH DEFAULT	Not used.	N
GRANTEDTS	TIMESTAMP NOT NULL WITH DEFAULT	Time when the GRANT statement was executed. The value is '1985-04-01.00.00.00.000000' for the one installation row.	G
CREATETMTABAUTH	CHAR(1) NOT NULL WITH DEFAULT	Whether the GRANTEE has CREATETMTABAUTH privilege: blank Privilege is not held G Privilege is held with the GRANT option Y Privilege is held without the GRANT option	G

Column name	Data type	Description	Use
GRANTEETYPE	CHAR(1) NOT NULL WITH DEFAULT	Indicates the type of grantee: blank Authorization ID L Role	G
GRANTORTYPE	CHAR(1) NOT NULL WITH DEFAULT	Indicates the type of grantor: blank Authorization ID L Role	G
DEBUGSESSIONAUTH	CHAR(1) NOT NULL WITH DEFAULT	Whether the GRANTEE has DEBUGSESSION privilege: blank Privilege is not held G Privilege is held with the GRANT option Y Privilege is held without the GRANT option	G
EXPLAINAUTH	CHAR(1) NOT NULL WITH DEFAULT	Whether the GRANTEE can explain and prepare statements: blank Privilege is not held G Privilege is held with the GRANT option Y Privilege is held without the GRANT option	G
SQLADMAUTH	CHAR(1) NOT NULL WITH DEFAULT	Whether the GRANTEE has SQLADM authority: blank Privilege is not held G Privilege is held with the GRANT option Y Privilege is held without the GRANT option	G
SDBADMAUTH	CHAR(1) NOT NULL WITH DEFAULT	Whether the GRANTEE has system DBADM authority: blank Privilege is not held Y Privilege is held without the GRANT option	G

Column name	Data type	Description	Use
DATAACCESSAUTH	CHAR(1) NOT NULL WITH DEFAULT	Whether the GRANTEE has DATAACCESS authority: blank Privilege is not held Y Privilege is held without the GRANT option	G
ACCESSCTRLAUTH	CHAR(1) NOT NULL WITH DEFAULT	Whether the GRANTEE has ACCESSCTRL authority: blank Privilege is not held Y Privilege is held without the GRANT option	G
CREATESECUREAUTH	CHAR(1) NOT NULL WITH DEFAULT	Whether the GRANTEE can create secured objects (triggers and user-defined functions): blank Privilege is not held Y Privilege is held without the GRANT option	G
SYS_START	TIMESTAMP(12) NOT NULL GENERATED ALWAYS AS ROW BEGIN	Reserved for future IBM use.The row-begin column of the SYSTEM_TIME period, for system-period data versioning.	G
SYS_END	TIMESTAMP(12) NOT NULL GENERATED ALWAYS AS ROW END	Reserved for future IBM use.The row-end column of the SYSTEM_TIME period, for system-period data versioning.	G
TRANS_START	TIMESTAMP(12) NOT NULL GENERATED ALWAYS AS TRANSACTION START ID	Reserved for future IBM use.	G

SYSVARIABLEAUTH catalog table

The SYSVARIABLEAUTH table contains one row for each privilege of each authorization ID that has privileges on a global variable. The schema is SYSIBM.

Table 372. SYSIBM.SYSVARIABLEAUTH table column descriptions

Column name	Data type	Description	Use
GRANTOR	VARCHAR(128) NOT NULL	The grantor of the privilege.	G

Table 372. SYSIBM.SYSVARIABLEAUTH table column descriptions (continued)

Column name	Data type	Description	Use
GRANTORTYPE	CHAR(1) NOT NULL	The type of grantor: blank Grantor is an authorization ID L Grantor is a role	G
GRANTEE	VARCHAR(128) NOT NULL	The holder of the privilege.	G
GRANTEETYPE	CHAR(1) NOT NULL	The type of grantee: blank Grantee is an authorization ID L Grantee is a role P Grantee is a package. The grantee is a package if COLLID is a value other than blank. R Internal use only	G
SCHEMA	VARCHAR(128) NOT NULL	The schema name of the global variable.	G
NAME	VARCHAR(128) NOT NULL	The unqualified name of the global variable.	G
COLLID	VARCHAR(128) NOT NULL	If the grantee is a package, this value is the COLLID of the package.	G
CONTOKEN	CHAR(8) NOT NULL FOR BIT DATA	If the grantee is a package, this value is the consistency token of the DBRM from which the package is derived. Otherwise, this value is blank.	G
READAUTH	CHAR(1) NOT NULL	The privilege to read the global variable: blank The READ privilege is not held G The READ privilege is held with the GRANT option Y The READ privilege is held without the GRANT option	G

Table 372. SYSIBM.SYSVARIABLEAUTH table column descriptions (continued)

Column name	Data type	Description	Use
WRITEAUTH	CHAR(1) NOT NULL	The privilege to write to the global variable: blank The WRITE privilege is not held G The WRITE privilege is held with the GRANT option Y The WRITE privilege is held without the GRANT option	G
AUTHHOWGOT	CHAR(1) NOT NULL	The authorization level of the user who granted the privileges: blank Not applicable E SECADM G ACCESSCTRL S SYSADM T DATAACCESS This authorization level is not necessarily the highest authority level of the grantor.	G
GRANTEDTS	TIMESTAMP NOT NULL	The time when the GRANT statement was executed.	G
IBMREQD	CHAR(1) NOT NULL	A value of Y indicates that the row was provided with the Db2 product code. For all other values, see Release dependency indicators . The value in this field is not a reliable indicator of release dependencies.	G

SYSVARIABLES catalog table

The SYSVARIABLES table contains one row for each global variable that is created. The schema is SYSIBM.

Table 373. SYSIBM.SYSVARIABLES table column descriptions

Column name	Data type	Description	Use
VARID	BIGINT NOT NULL GENERATED ALWAYS AS IDENTITY	The identifier of the global variable.	G
SCHEMA	VARCHAR(128) NOT NULL	The schema name of the global variable.	G

Table 373. SYSIBM.SYSVARIABLES table column descriptions (continued)

Column name	Data type	Description	Use
NAME	VARCHAR(128) NOT NULL	The unqualified name of the global variable.	G
OWNER	VARCHAR(128) NOT NULL	The authorization ID of the owner of the global variable.	G
OWNERTYPE	CHAR(1) NOT NULL	The type of owner of the global variable: L The owner is a role blank The owner is an authorization ID	G
RELCREATED	CHAR(1) NOT NULL	The release of Db2 that is used to create the object. See Release dependency indicators for all other values.	G
CREATEDTS	TIMESTAMP NOT NULL	Time at which the global variable was created.	G
TYPESHEMA	VARCHAR(128) NOT NULL	The schema name of the data type. For built-in data types, this value is SYSIBM.	G
TYPENAME	VARCHAR(128) NOT NULL	The unqualified name of the data type.	G
DATATYPEID	INTEGER NOT NULL	For a built-in data type, the internal ID of the built-in type. For a user-defined type, the internal ID of the user-defined type.	S
SOURCETYPEID	INTEGER NOT NULL	For a built-in data type, 0. For a user-defined type, the internal ID of the built-in data type on which the user-defined type is based.	S
LENGTH	INTEGER NOT NULL	The maximum length of the global variable. If the variable is an array type, the value is 0.	G
SCALE	SMALLINT NOT NULL	The scale of the global variable.	G
CCSID	INTEGER NOT NULL	If the variable is an array type, the value is 0. Otherwise, the CCSID of the global variable.	G

Table 373. SYSIBM.SYSVARIABLES table column descriptions (continued)

Column name	Data type	Description	Use
DEFAULT	CHAR(3) NOT NULL	<p>The default value of the global variable.</p> <p>This column can contain one of the following values:</p> <p>N The global variable does not have a default value. If the variable is an array type, the value is N.</p> <p>S The default value is the value of the SQL authorization ID of the process at the time that a default value is used.</p> <p>1 The default value is a string constant.</p> <p>2 The default value is a floating-point constant.</p> <p>3 The default value is a decimal constant.</p> <p>4 The default value is an integer constant.</p> <p>5 The default value is a hexadecimal character string.</p> <p>6 The default value is a UX string.</p> <p>7 The global variable has a graphic data type and has a default value that is a character string constant.</p> <p>8 The global variable has a character data type and has a default value that is a character string constant.</p> <p>9 The default value is a DECFLOAT constant</p> <p>If this column contains one of the following values, the default value of the global variable is the value of the indicated special register at the time that a default value is used:</p> <p>AES <u>CURRENT APPLICATION ENCODING SCHEME</u></p> <p>ACT <u>CURRENT CLIENT_ACCTNG</u></p> <p>APN <u>CURRENT CLIENT_APPLNAME</u></p> <p>CID <u>CURRENT CLIENT_USERID</u></p>	G

Table 373. SYSIBM.SYSVARIABLES table column descriptions (continued)

Column name	Data type	Description	Use
DEFAULT (continued)		WSN <u>CURRENT CLIENT_WRKSTNNAME</u>	
		DAT <u>CURRENT DATE</u>	
		DBG <u>CURRENT DEBUG MODE</u>	
		DEC <u>CURRENT DECFLOAT ROUNDING MODE</u>	
		DEG <u>CURRENT DEGREE</u>	
		EXP <u>CURRENT EXPLAIN MODE</u>	
		LCT <u>CURRENT LOCALE LC_CTYPE</u>	
		MTT <u>CURRENT MAINTAINED TABLE TYPES FOR OPTIMIZATION</u>	
		MEM <u>CURRENT MEMBER</u>	
		HNT <u>CURRENT OPTIMIZATION HINT</u>	
		CPP <u>CURRENT PACKAGE PATH</u>	
		CPS <u>CURRENT PACKAGESET</u>	
		PTH <u>CURRENT PATH</u>	
		PRC <u>CURRENT PRECISION</u>	
		RFA <u>CURRENT REFRESH AGE</u>	
		RVS <u>CURRENT ROUTINE VERSION</u>	
		RUL <u>CURRENT RULES</u>	
		SCH <u>CURRENT SCHEMA</u>	
		SVR <u>CURRENT SERVER</u>	
		TIM <u>CURRENT TIME</u>	
		TST <u>CURRENT TIMESTAMP</u>	
		STZ <u>SESSION TIME ZONE</u>	
		U <u>SESSION_USER</u>	

Table 373. SYSIBM.SYSVARIABLES table column descriptions (continued)

Column name	Data type	Description	Use
ROWID	ROWID NOT NULL GENERATED ALWAYS	The ROWID value for the lob columns in this table.	G
DEFAULTTEXT	CLOB(2M) NOT NULL WITH DEFAULT	The text of the default value of the global variable.	G
—	BLOB(2M) NOT NULL	Reserved for future IBM use.	I
ENVID	INTEGER NOT NULL	Internal environment identifier.	G
REMARKS	VARCHAR(762) NOT NULL	A character string about this global variable that is provided by using the COMMENT statement.	G
IBMREQD	CHAR(1) NOT NULL	A value of Y indicates that the row was provided with the Db2 product code. For all other values, see Release dependency indicators . The value in this field is not a reliable indicator of release dependencies. RELCREATED should be used instead.	G

SYSVARIABLES_DESC catalog table

The SYSVARIABLES_DESC table is an auxiliary table for the SYSIBM.SYSVARIABLES table. The schema is SYSIBM.

Table 374. SYSIBM.SYSVARIABLES table column descriptions

Column name	Data type	Description	Use
—	BLOB(2M)	Internal use only.	I

SYSVARIABLES_TEXT catalog table

The SYSVARIABLES_TEXT table is an auxiliary table for the DEFAULTTEXT column of the SYSVARIABLES table. The schema is SYSIBM.

Table 375. SYSIBM.SYSVARIABLES_TEXT table column descriptions

Column name	Data type	Description	Use
DEFAULTTEXT	CLOB(2M)	The text of the default value of the global variable.	G

SYSVIEWDEP catalog table

The SYSVIEWDEP table records the dependencies of views, SQL function tables, and materialized query tables on other objects. The schema is SYSIBM.

Table 376. SYSIBM.SYSVIEWDEP table column descriptions

Column name	Data type	Description	Use
BNAME	VARCHAR(128) NOT NULL	Name of the object on which the view, SQL function, or materialized query table is dependent. If the object type is a function (BTYPE='F'), the name is the specific name of the function.	G
BCREATOR	VARCHAR(128) NOT NULL	Authorization ID of the owner of BNAME.	G
BTYPE	CHAR(1) NOT NULL	Type of object: F Function G Created global temporary table M Materialized query table T Table V View W SYSTEM_TIME period Z BUSINESS_TIME period	G
DNAME	VARCHAR(128) NOT NULL	Name of the view.	G
DCREATOR	VARCHAR(128) NOT NULL	The schema of the view.	G
IBMREQD	CHAR(1) NOT NULL	A value of Y indicates that the row was provided with the Db2 product code. For all other values, see Release dependency indicators . The value in this field is not a reliable indicator of release dependencies.	G
BSCHEMA	VARCHAR(128) NOT NULL WITH DEFAULT	Schema of BNAME.	G

Table 376. SYSIBM.SYSVIEWDEP table column descriptions (continued)

Column name	Data type	Description	Use
DTYPE	CHAR(1) NOT NULL	Type of dependent object: F SQL function M Materialized query table V View	G
DOWNER	VARCHAR(128) NOT NULL WITH DEFAULT	Authorization ID of the dependent object. Blank for views that were created in a Db2 release prior to Version 9.	G
OWNERTYPE	CHAR(1) NOT NULL WITH DEFAULT	Indicates the type of owner: blank Authorization ID L Role	G
SYS_START	TIMESTAMP(12) NOT NULL GENERATED ALWAYS AS ROW BEGIN	Reserved for future IBM use.	G
SYS_END	TIMESTAMP(12) NOT NULL GENERATED ALWAYS AS ROW END	Reserved for future IBM use.	G
TRANS_START	TIMESTAMP(12) NOT NULL GENERATED ALWAYS AS TRANSACTION START ID	Reserved for future IBM use.	G

SYSVIEWS catalog table

The SYSVIEWS table contains one or more rows for each view, materialized query table, or user-defined SQL function. The schema is SYSIBM.

Column name	Data type	Description	Use
NAME	VARCHAR(128) NOT NULL	Name of the object.	G
CREATOR	VARCHAR(128) NOT NULL	The schema of the object.	G
SEQNO	SMALLINT NOT NULL	Not used.	N

Column name	Data type	Description	Use
CHECK	CHAR(1) NOT NULL	Whether the WITH CHECK OPTION clause was specified in the CREATE VIEW statement: N No C Yes with the <i>cascaded</i> semantic Y Yes with the <i>local</i> semantic The value is N if the view has no WHERE clause, or the object is not a view.	G
IBMREQD	CHAR(1) NOT NULL	A value of Y indicates that the row was provided with the Db2 product code. For all other values, see Release dependency indicators . The value in this field is not a reliable indicator of release dependencies. RELCREATED should be used instead.	G
TEXT	VARCHAR(1500) NOT NULL	Not used.	N
PATHSCHEMAS	VARCHAR(2048) NOT NULL WITH DEFAULT	SQL path at the time the object was defined. The path is used to resolve unqualified data type and function names used in the object definition.	G
RELCREATED	CHAR(1) NOT NULL	The release of Db2 that is used to create the object. Blank if created prior to Version 9. See Release dependency indicators for all other values.	G
TYPE	CHAR(1) NOT NULL	Type of table: F SQL function M Materialized query table V View	G
REFRESH	CHAR(1) NOT NULL WITH DEFAULT	Refresh mode: D A materialized query table with a deferred refresh mode blank Not a materialized query table	G
ENABLE	CHAR(1) NOT NULL WITH DEFAULT	Indicates whether query optimization is enabled: Y Enabled N Disabled blank Not a materialized query table	G

Column name	Data type	Description	Use
MAINTENANCE	CHAR(1) NOT NULL WITH DEFAULT	Maintenance mode: S For a REFRESH = 'D', a materialized query table that is maintained by the system. U For a REFRESH = 'D', a materialized query table that is maintained by the user. blank Not a materialized query table.	G
REFRESH_TIME	TIMESTAMP NOT NULL WITH DEFAULT	For REFRESH = 'D' and MAINTENANCE = 'S', the timestamp of the REFRESH TABLE statement that last refreshed the data. Otherwise, this is the default timestamp ('0001-01-01.00.00.000000').	G
ISOLATION	CHAR(1) NOT NULL WITH DEFAULT	Isolation level when the materialized query table is created or altered from a base table: R RR (repeatable read) S CS (cursor stability) T RS (read stability) U UR (uncommitted read) blank Not a materialized query table	G
SIGNATURE	VARCHAR(1024) NOT NULL WITH DEFAULT FOR BIT DATA	Contains an internal description. Used for materialized query tables.	G
APP_ENCODING_CCSID	INTEGER NOT NULL WITH DEFAULT	CCSID of the current application encoding scheme at the time the object was created. For objects created prior to Version 8 of Db2, the value is 0.	G
OWNER	VARCHAR(128) NOT NULL WITH DEFAULT	Authorization ID of the owner of the view, blank for views that were created in a Db2 release prior to Version 9.	G
OWNERTYPE	CHAR(1) NOT NULL WITH DEFAULT	Indicates the type of owner: blank Authorization ID L Role	G
ENVID	INTEGER NOT NULL WITH DEFAULT	Internal environment identifier.	G

Column name	Data type	Description	Use
ROWID	ROWID NULL GENERATED ALWAYS	ROWID column, created for the lob columns in this table	G
STATEMENT	CLOB(2M) NOT NULL WITH DEFAULT	The text of the statement that created the view. In some cases, this column might instead contain the text of a statement that altered the view. In many cases, changes to views or to objects on which views are dependent do not update this value.	G
—	BLOB(1G) NOT NULL WITH DEFAULT	Internal use only.	I

SYSVIEWS_STMT catalog table

The SYSVIEWS_STMT table is an auxiliary table for the STATEMENT column of the SYSIBM.SYSVIEWS table and is required to hold LOB data. The schema is SYSIBM.

Table 377. SYSIBM.SYSVIEWS_STMT table column descriptions

Column name	Data type	Description	Use
STATEMENT	CLOB(2M) NOT NULL WITH DEFAULT	See the description of the STATEMENT column in “SYSVIEWS catalog table” on page 2730	G

SYSVIEWS_TREE catalog table

The SYSVIEWS_TREE table is an auxiliary table for the PARSETREE column of the SYSVIEWS table and is required to hold LOB data. The schema is SYSIBM.

Table 378. SYSIBM.SYSVIEWS_TREE table column descriptions

Column name	Data type	Description	Use
—	BLOB(1G) NOT NULL WITH DEFAULT	Internal use only.	I

SYSVOLUMES catalog table

The SYSVOLUMES table contains one row for each volume of each storage group. The schema is SYSIBM.

Table 379. SYSIBM.SYSVOLUMES table column descriptions

Column name	Data type	Description	Use
SGNAME	VARCHAR(128) NOT NULL	Name of the storage group.	G

Table 379. SYSIBM.SYSVOLUMES table column descriptions (continued)

Column name	Data type	Description	Use
SGCREATOR	VARCHAR(128) NOT NULL	Authorization ID of the owner of the storage group. To determine the type of authorization ID for the storage group creator, see the CREATORTYPE column of the SYSIBM.SYSSTOGROUP catalog table.	G
VOLID	VARCHAR(18) NOT NULL	Serial number of the volume or * if SMS-managed.	G
IBMREQD	CHAR(1) NOT NULL	A value of Y indicates that the row was provided with the Db2 product code. For all other values, see Release dependency indicators . The value in this field is not a reliable indicator of release dependencies. RELCREATED should be used instead.	G
RELCREATED	CHAR(1) NOT NULL	The release of Db2 that is used to create the object. Blank if created prior to Version 9. See Release dependency indicators for all other values.	G

SYSXMLRELS catalog table

The SYSXMLRELS table contains one row for each XML table that is created for an XML column. The schema is SYSIBM.

Table 380. SYSIBM.SYSXMLRELS table column descriptions

Column name	Data type	Description	Use
TBOWNER	VARCHAR(128) NOT NULL	Schema or qualifier of the base table.	G
TBNAME	VARCHAR(128) NOT NULL	Name of the base table.	G
COLNAME	VARCHAR(128) NOT NULL	Name of the XML column in the base table.	G
XMLTBOWNER	VARCHAR(128) NOT NULL	Schema or qualifier of the XML table.	G
XMLTBNAME	VARCHAR(128) NOT NULL	Name of the XML table.	G
XMLRELOBID	INTEGER NOT NULL	Internal identifier of the relationship between the base table and the XML table.	G

Table 380. SYSIBM.SYSXMLRELS table column descriptions (continued)

Column name	Data type	Description	Use
IBMREQD	CHAR(1) NOT NULL	A value of Y indicates that the row was provided with the Db2 product code. For all other values, see Release dependency indicators . The value in this field is not a reliable indicator of release dependencies. RELCREATED should be used instead.	G
CREATEDTS	TIMESTAMP NOT NULL	Time when the XML table was created.	G
RELCREATED	CHAR(1) NOT NULL	The release of Db2 that is used to create the object. See Release dependency indicators for the values.	G

SYSXMLSTRINGS catalog table

Each row of the SYSXMLSTRINGS table contains a single string and its unique ID that are used to condense XML data. The string can be an element name, attribute name, name space prefix, or a namespace URI. The schema is SYSIBM.

Table 381. SYSIBM.SYSXMLSTRINGS table column descriptions

Column name	Data type	Description	Use
STRINGID	INTEGER NOT NULL GENERATED ALWAYS AS IDENTITY	Unique ID for the string.	G
STRING	VARCHAR(1000) NOT NULL	The string data.	G
IBMREQD	CHAR(1) NOT NULL	A value of Y indicates that the row was provided with the Db2 product code. For all other values, see Release dependency indicators . The value in this field is not a reliable indicator of release dependencies.	G

SYSXMLTYPMOD catalog table

The SYSXMLTYPMOD table contains rows about the XML type modifiers of XML columns. Rows in this table can be inserted, updated and deleted. The schema is SYSIBM.

Table 382. SYSIBM.SYSXMLTYPMOD table column descriptions

Column name	Data type	Description	Use
XML_TYPMOD_ID	INTEGER NOT NULL GENERATED ALWAYS AS IDENTITY	An id generated for the XML type modifier, it is an identity column and primary key.	G

Table 382. SYSIBM.SYSXMLTYPMOD table column descriptions (continued)

Column name	Data type	Description	Use
TYPE_ANNOTATION	CHAR(1) NOT NULL	Indicate whether there is type annotation. Y WITH type annotation N with no type annotation.	G
CREATEDTS	TIMESTAMP NOT NULL	The timestamp when this type modifier is created.	G
ALTEREDTS	TIMESTAMP NOT NULL	The timestamp when this type modifier is altered	G
RELCREATED	CHAR(1) NOT NULL	The release of Db2 that is used to create the object. See Release dependency indicators for the values.	G
IBMREQD	CHAR(1) NOT NULL	A value of Y indicates that the row was provided with the Db2 product code. For all other values, see Release dependency indicators . The value in this field is not a reliable indicator of release dependencies. RELCREATED should be used instead.	G
CREATEDBY	VARCHAR(128) NOT NULL	Primary authorization ID of the user who created the database.	G

SYSXMLTYPMSCHEMA catalog table

The SYSXMLTYPMSCHEMA table contains the XML schema information for an XML type modifier. It contains one row per XML schema for an XML type modifier. The schema is SYSIBM.

Table 383. SYSIBM.SYSXMLTYPMSCHEMA table column descriptions

Column name	Data type	Description	Use
XML_TYPMOD_ID	INTEGER NOT NULL	The id for the XML type modifier.	G
XSROBJECTID	INTEGER NOT NULL	The id for an XML schema registered in XSR.	G
ELEMENT_NAMESPACE	INTEGER NOT NULL	String id for the namespace name of the root element node. By default, it is the TARGETNAMESPACE of the XML schema. It would be 0 if it is NO NAMESPACE.	G
ELEMENT_NAME	INTEGER NOT NULL	String id for the local name of the root element node. It would be 0 if it is not specified.	G
CREATEDTS	TIMESTAMP NOT NULL	The timestamp when this type modifier is created.	G

Table 383. SYSIBM.SYSXMLTYPMSHEMA table column descriptions (continued)

Column name	Data type	Description	Use
ALTEREDTS	TIMESTAMP NOT NULL	The timestamp when this type modifier is altered	G
RELCREATED	CHAR(1) NOT NULL	The release of Db2 that is used to create the object. See Release dependency indicators for the values.	G
IBMREQD	CHAR(1) NOT NULL	A value of Y indicates that the row was provided with the Db2 product code. For all other values, see Release dependency indicators . The value in this field is not a reliable indicator of release dependencies. RELCREATED should be used instead.	G

USERNAMES table

Each row in the USERNAMES table is used to carry out one outbound ID translation or inbound ID translation and "come from" checking. The schema is SYSIBM.

Rows in this table can be inserted, updated, and deleted.

Table 384. SYSIBM.USERNAMES table column descriptions

Column name	Data type	Description	Use
TYPE	CHAR(1) NOT NULL	How the row is to be used: I For inbound translation and "come from" checking. O For outbound translation. S For outbound system AUTHID to establish a trusted connection.	G
AUTHID	VARCHAR(128) NOT NULL WITH DEFAULT	Authorization ID to be translated. Applies to any authorization ID if blank.	G

Table 384. SYSIBM.USERNAMES table column descriptions (continued)

Column name	Data type	Description	Use
LINKNAME	VARCHAR(24) NOT NULL	<p>Identifies the VTAM or TCP/IP network locations associated with this row. A blank value in this column indicates this name translation rule applies to any TCP/IP or SNA partner.</p> <p>If a non-blank LINKNAME is specified, one or both of the following statements must be true:</p> <ul style="list-style-type: none"> • A row exists in SYSIBM.LUNAMES whose LUNAME matches the value specified in the SYSIBM.USERNAMES LINKNAME column. This row specifies the VTAM site associated with this name translation rule. • A row exists in SYSIBM.IPNAMES whose LINKNAME matches the value specified in the SYSIBM.USERNAMES LINKNAME column. This row specifies the TCP/IP host associated with this name translation rule. <p>Inbound name translation and "come from" checking are not performed for TCP/IP clients.</p>	G
NEWAUTHID	VARCHAR(128) NOT NULL WITH DEFAULT	Translated value of AUTHID. Blank specifies no translation. NEWAUTHID can be stored as encrypted data by calling the DSNLEUSR stored procedure. To send the encrypted value of AUTHID across a network, one of the encryption security options in the SYSIBM.IPNAMES table should be specified.	G
PASSWORD	VARCHAR(255) NOT NULL WITH DEFAULT	Password to accompany an outbound request, if passwords are not encrypted by RACF. If passwords are encrypted, or the row is for inbound requests, the column is not used. PASSWORD can be stored as encrypted data by calling the DSNLEUSR stored procedure. To send the encrypted value of PASSWORD across a network, one of the encryption security options in the SYSIBM.IPNAMES table should be specified.	G
IBMREQD	CHAR(1) NOT NULL WITH DEFAULT 'N'	<p>A value of Y indicates that the row was provided with the Db2 product code. For all other values, see Release dependency indicators.</p> <p>The value in this field is not a reliable indicator of release dependencies.</p>	G

Reorganizing the catalog

The REORG TABLESPACE utility can be run on all the table spaces in the catalog database (DSNDB06) to reclaim unused or wasted space, which can affect performance.

For best results, also run the REORG TABLESPACE utility for any altered Db2 catalog objects that a CATMAINT utility job places in REORG-pending (AREO*) advisory status.

The REORG TABLESPACE utility observes the PCTFREE and FREEPAGE values specified in the ALTER INDEX statement for all the catalog indexes and the following table spaces:

- DSNDB06.SYSDDF

- DSNDB06.SYSGPAUT
- DSNDB06.SYSGRTNS
- DSNDB06.SYSHIST
- DSNDB06.SYSJAVA
- DSNDB06.SYSJAUXA
- DSNDB06.SYSJAUXB
- DSNDB06.SYSSEQ
- DSNDB06.SYSSEQ2
- DSNDB06.SYSSTATS
- DSNDB06.SYSTSCHX
- DSNDB06.SYSTSCKD
- DSNDB06.SYSTSCKS
- DSNDB06.SYSTSCPY
- DSNDB06.SYSTSSRG
- DSNDB06.SYSUSER
- DSNDB01.SCT02
- DSNDB01.SPT01

Related tasks

[Reserving free space in table spaces \(Db2 Performance\)](#)

Related reference

[REORG TABLESPACE \(Db2 Utilities\)](#)

[ALTER INDEX statement](#)

The ALTER INDEX statement changes the description of an index at the current server.

SQL statements allowed on the catalog

Certain SQL statements can be used to change the value of certain options for existing catalog indexes, sequences, and table spaces, or to add indexes to any of the catalog tables.

Table 385. SQL statements that can be used to change existing catalog indexes, sequences, and table spaces, or to add indexes to any of the catalog tables

SQL statement	Index	Allowable clauses and usage notes
ALTER INDEX	IBM-defined	<p>Only these clauses are allowed:</p> <p>CLOSE COPY FREEPAGE GBPCACHE NOT PADDED PADDED PCTFREE PIECESIZE</p> <p>You cannot alter the GBPCACHE value for indexes DSNDX01, DSNDX02, and DSNDX03, which are on catalog table SYSIBM.SYSINDEXES.</p>

Table 385. SQL statements that can be used to change existing catalog indexes, sequences, and table spaces, or to add indexes to any of the catalog tables (continued)

SQL statement	Index	Allowable clauses and usage notes
ALTER INDEX	User-created	All clauses are allowed, except for the following: BUFFERPOOL REGENERATE COMPRESS YES Any partitioning clause
ALTER SEQUENCE		The only clause allowed is MAXVALUE. You can only change the MAXVALUE value of the catalog sequence DSNSEQ_IMPLICITDB. The only value specific must be an integer in the range 1–60000, inclusive.
ALTER TABLE		Only these clauses are allowed: DATA CAPTURE CHANGES ADD VERSIONING DROP VERSIONING ADD PERIOD The ADD VERSIONING, DROP VERSIONING, and ADD PERIOD clauses can be specified on only the following tables: <ul style="list-style-type: none"> • SYSIBM.SYSTABLESPACESTATS • SYSIBM.SYSINDEXSPACESTATS

Table 385. SQL statements that can be used to change existing catalog indexes, sequences, and table spaces, or to add indexes to any of the catalog tables (continued)

SQL statement	Index	Allowable clauses and usage notes																																		
ALTER TABLESPACE		<p>Only these clauses are allowed:</p> <ul style="list-style-type: none"> • CLOSE • FREEPAGE • GBPCACHE • LOCKMAX • MAXROWS • PCTFREE • TRACKMOD <p>For DSNDB06.SYSSEQ, MAXROW can be specified only with a value of 1.</p> <p>You can specify the LOCKSIZE keyword on the ALTER TABLESPACE statement for any catalog table spaces that are not LOB table spaces.</p> <p>You cannot alter the GBPCACHE or MAXROWS value of some catalog table spaces. Do not specify GBPCACHE for the following table spaces:</p>																																		
		<table style="width: 100%; border: none;"> <thead> <tr> <th style="text-align: left; border: none;">Table spaces</th> <th style="text-align: left; border: none;">Table spaces</th> </tr> </thead> <tbody> <tr><td style="border: none;">• DSNDB06.SYSTSCOL</td><td style="border: none;">• DSNDB06.SYSTSPKS</td></tr> <tr><td style="border: none;">• DSNDB06.SYSTSDBA</td><td style="border: none;">• DSNDB06.SYSTSPKX</td></tr> <tr><td style="border: none;">• DSNDB06.SYSTSDBR</td><td style="border: none;">• DSNDB06.SYSTSPKY</td></tr> <tr><td style="border: none;">• DSNDB06.SYSTSDBU</td><td style="border: none;">• DSNDB06.SYSTSPLA</td></tr> <tr><td style="border: none;">• DSNDB06.SYSTSFAU</td><td style="border: none;">• DSNDB06.SYSTSPLD</td></tr> <tr><td style="border: none;">• DSNDB06.SYSTSFLD</td><td style="border: none;">• DSNDB06.SYSTSPLN</td></tr> <tr><td style="border: none;">• DSNDB06.SYSTSFOR</td><td style="border: none;">• DSNDB06.SYSTSPLY</td></tr> <tr><td style="border: none;">• DSNDB06.SYSTSIPT</td><td style="border: none;">• DSNDB06.SYSTSPVR</td></tr> <tr><td style="border: none;">• DSNDB06.SYSTSIXR</td><td style="border: none;">• DSNDB06.SYSTSREL</td></tr> <tr><td style="border: none;">• DSNDB06.SYSTSIXS</td><td style="border: none;">• DSNDB06.SYSTSSTM</td></tr> <tr><td style="border: none;">• DSNDB06.SYSTSIXT</td><td style="border: none;">• DSNDB06.SYSTSSYN</td></tr> <tr><td style="border: none;">• DSNDB06.SYSTSKEY</td><td style="border: none;">• DSNDB06.SYSTSTAB</td></tr> <tr><td style="border: none;">• DSNDB06.SYSTSPKA</td><td style="border: none;">• DSNDB06.SYSTSTAU</td></tr> <tr><td style="border: none;">• DSNDB06.SYSTSPKD</td><td style="border: none;">• DSNDB06.SYSTSTPT</td></tr> <tr><td style="border: none;">• DSNDB06.SYSTSPKG</td><td style="border: none;">• DSNDB06.SYSTSTSP</td></tr> <tr><td style="border: none;">• DSNDB06.SYSTSPKL</td><td></td></tr> </tbody> </table>	Table spaces	Table spaces	• DSNDB06.SYSTSCOL	• DSNDB06.SYSTSPKS	• DSNDB06.SYSTSDBA	• DSNDB06.SYSTSPKX	• DSNDB06.SYSTSDBR	• DSNDB06.SYSTSPKY	• DSNDB06.SYSTSDBU	• DSNDB06.SYSTSPLA	• DSNDB06.SYSTSFAU	• DSNDB06.SYSTSPLD	• DSNDB06.SYSTSFLD	• DSNDB06.SYSTSPLN	• DSNDB06.SYSTSFOR	• DSNDB06.SYSTSPLY	• DSNDB06.SYSTSIPT	• DSNDB06.SYSTSPVR	• DSNDB06.SYSTSIXR	• DSNDB06.SYSTSREL	• DSNDB06.SYSTSIXS	• DSNDB06.SYSTSSTM	• DSNDB06.SYSTSIXT	• DSNDB06.SYSTSSYN	• DSNDB06.SYSTSKEY	• DSNDB06.SYSTSTAB	• DSNDB06.SYSTSPKA	• DSNDB06.SYSTSTAU	• DSNDB06.SYSTSPKD	• DSNDB06.SYSTSTPT	• DSNDB06.SYSTSPKG	• DSNDB06.SYSTSTSP	• DSNDB06.SYSTSPKL	
Table spaces	Table spaces																																			
• DSNDB06.SYSTSCOL	• DSNDB06.SYSTSPKS																																			
• DSNDB06.SYSTSDBA	• DSNDB06.SYSTSPKX																																			
• DSNDB06.SYSTSDBR	• DSNDB06.SYSTSPKY																																			
• DSNDB06.SYSTSDBU	• DSNDB06.SYSTSPLA																																			
• DSNDB06.SYSTSFAU	• DSNDB06.SYSTSPLD																																			
• DSNDB06.SYSTSFLD	• DSNDB06.SYSTSPLN																																			
• DSNDB06.SYSTSFOR	• DSNDB06.SYSTSPLY																																			
• DSNDB06.SYSTSIPT	• DSNDB06.SYSTSPVR																																			
• DSNDB06.SYSTSIXR	• DSNDB06.SYSTSREL																																			
• DSNDB06.SYSTSIXS	• DSNDB06.SYSTSSTM																																			
• DSNDB06.SYSTSIXT	• DSNDB06.SYSTSSYN																																			
• DSNDB06.SYSTSKEY	• DSNDB06.SYSTSTAB																																			
• DSNDB06.SYSTSPKA	• DSNDB06.SYSTSTAU																																			
• DSNDB06.SYSTSPKD	• DSNDB06.SYSTSTPT																																			
• DSNDB06.SYSTSPKG	• DSNDB06.SYSTSTSP																																			
• DSNDB06.SYSTSPKL																																				

Table 385. SQL statements that can be used to change existing catalog indexes, sequences, and table spaces, or to add indexes to any of the catalog tables (continued)

SQL statement	Index	Allowable clauses and usage notes
CREATE INDEX	User-created	<p>All clauses are allowed, except for:</p> <ul style="list-style-type: none"> CLOSE YES CLUSTER UNIQUE DEFER YES (only on tables SYSINDEXES, SYSINDEXPART, and SYSKEYS) COMPRESS YES Any partitioning clause <p>The USING clause is ignored.</p> <p>Indexes that are created with <i>key-expressions</i> are not allowed on the catalog.</p> <p>The only value allowed for BUFFERPOOL is BP0.</p> <p>You can create up to 500 indexes on the catalog.</p>
DROP INDEX	User-created	The statement has no clauses.

Temporal versioning for Db2 catalog tables

Db2 12 can use temporal versioning to record historical information for certain catalog tables. You can use the historical information in statistics-related catalog tables to analyze, predict, and help prevent specific conditions in a subsystem.

[FL 500](#)

Related concepts

[Temporal tables and data versioning \(Db2 Administration Guide\)](#)

[Recovery of temporal tables with system-period data versioning \(Db2 Administration Guide\)](#)

[When Db2 externalizes real-time statistics \(Db2 Performance\)](#)

Related tasks

[Creating a system-period temporal table \(Db2 Administration Guide\)](#)

[Querying temporal tables \(Db2 Administration Guide\)](#)

[Collecting history statistics \(Db2 Performance\)](#)

Temporal versioning for Db2 statistics-related catalog tables

You can use the historical information in Db2 12 statistics-related catalog tables to analyze, predict, and help prevent specific conditions in a subsystem.

[FL 500](#)

The historical information for real-time statistics catalog tables can be used to analyze the rate of change in size, organization, and activity for table space and index space partitions. This information can then be used to develop an automated response to conditions such as table spaces and index spaces running out of space or becoming too disorganized.

The following table lists the statistics-related catalog tables that have an associated history table for system-period temporal versioning.

Catalog table	History table
SYSINDEXSPACESTATS	SYSIBM.SYSIXSPACESTATS_H

Catalog table	History table
SYSTABLESPACESTATS	SYSIBM.SYSTABSPACESTATS_H

Enabling the temporal relationship

The temporal relationship between a history table and its associated catalog table must be enabled before the history table can be used to record historical information. Each member Db2 externalizes rows whenever the interval specified by the STATSINT subsystem parameter is reached.

Tip: It is best to develop and test an aggregation and purge strategy before enabling the temporal relationship.

To enable the temporal relationship for SYSIBM.SYSINDEXSPACESTATS and its associated history table, SYSIBM.SYSIXSPACESTATS_H, issue the following statement:

```
ALTER TABLE SYSIBM.SYSINDEXSPACESTATS
ADD VERSIONING
USE HISTORY TABLE SYSIBM.SYSIXSPACESTATS_H;
```

To enable the temporal relationship for SYSIBM.SYSTABLESPACESTATS and its associated history table, SYSIBM.SYSTABSPACESTATS_H, issue the following statement:

```
ALTER TABLE SYSIBM.SYSTABLESPACESTATS
ADD VERSIONING
USE HISTORY TABLE SYSIBM.SYSTABSPACESTATS_H;
```

If the temporal relationship between a catalog table and its associated history table later needs to be removed, you can issue the ALTER TABLE statement with the DROP VERSIONING clause on the catalog table.

Multiple inserts into a temporal history table for one insert into a real-time statistics table

In rare cases, statistics-related catalog history tables might contain multiple rows that correspond to a single insert into a real-time statistics table. This can happen when real-time statistics are externalized to one of the real-time statistics tables, and the real-time statistics table is unavailable.

When temporal versioning is enabled, and Db2 inserts a row into a real-time statistics table, Db2 also inserts a row into the corresponding temporal history table. If the insert operation for the real-time statistics table fails because the table is unavailable, Db2 does not delete the row from the temporal history table. Db2 makes additional attempts to insert the row into the real-time statistics table, and with the each attempt, Db2 inserts another row into the temporal history table. When the real-time statistics table becomes available, and the insert into the real-time statistics table is successful, Db2 writes another row into the temporal history table.

The following example shows the contents of the SYS_START and SYS_END columns in system-period temporal table SYSIBM.SYSTABSPACESTATS_H when two unsuccessful attempts and one successful attempt are made to insert rows into a real-time statistics table. All column values other than SYS_END are the same. The first row corresponds to the successful attempt to insert into SYSIBM.SYSTABLESPACESTATS, and the second and third rows correspond to the unsuccessful attempts.

```
SYS_START          SYS_END
-----
2020-05-13-13.03.42.279115 2020-05-13-13.39.04.139589
2020-05-13-13.03.42.279115 2020-05-13-13.21.57.603570
2020-05-13-13.03.42.279115 2020-05-13-13.13.14.991616
```

Related concepts

[Temporal tables and data versioning \(Db2 Administration Guide\)](#)

[Recovery of temporal tables with system-period data versioning \(Db2 Administration Guide\)](#)

[When Db2 externalizes real-time statistics \(Db2 Performance\)](#)

Related tasks

[Creating a system-period temporal table \(Db2 Administration Guide\)](#)

[Querying temporal tables \(Db2 Administration Guide\)](#)

[Collecting history statistics \(Db2 Performance\)](#)

Catalog indexes

Indexes are defined on most catalog tables to improve catalog access.

The following table identifies the Db2 catalog tables on which indexes are defined, the columns that are in each of the indexes, and the data types of those columns.

Table 386. Indexes on Db2 catalog tables

Table	Index (type ^{"1"} on page 2767)	Columns (data type)
IPLIST	DSNDUX01 (U)	LINKNAME (CHAR(8)) IPADDR (VARCHAR(254))
IPNAMES	DSNFPX01 (UC)	LINKNAME (CHAR(8))
LOCATIONS	DSNFCX01 (UC)	LOCATION (VARCHAR(128))
LULIST	DSNFLX01 (UC)	LINKNAME (CHAR(8)) LUNAME (VARCHAR(24))
	DSNFLX02 (U)	LINKNAME (CHAR(8))
LUNAMES	DSNFNX01 (UC)	LUNAME (VARCHAR(24))
LUMODES	DSNFMX01 (UC)	LUNAME (VARCHAR(24)) MODENAME (VARCHAR(24))
MODESELECT	DSNFDX01 (UC)	LUNAME (VARCHAR(24)) AUTHID (VARCHAR(128)) PLANNAME (CHAR(8))
SYSAUDITPOLICIES	DSNAPX03 (UC)	AUDITPOLICYNAME (VARCHAR(128))
SYSAUTOALERTS	DSNALX01 (UC)	ALERT_ID (BIGINT)
	DSNALX02 (N)	HISTORY_ENTRY_ID (BIGINT)
	DSNALX03 (N)	RETURN_CODE (INTEGER) ACTION (VARCHAR(32))
	DSNALX04 (N)	TARGET_QUALIFIER (VARCHAR(128)) TARGET_OBJECT (VARCHAR(128)) TARGET_PARTITION (SMALLINT)
	DSNALX05 (N)	CREATEDTS (TIMESTAMP)

Table 386. Indexes on Db2 catalog tables (continued)

Table	Index (type "1" on page 2767)	Columns (data type)
	DSNALX06 (N)	STARTTS (TIMESTAMP) RETURN_CODE (INTEGER) ACTION (VARCHAR(32))
SYSAUTOALERTS_OUT	DSNALX07 (A)	OUTPUT (CLOB(2M))
SYSAUTORUNS_HIST	DSNPXH01 (UC)	HISTORY_ENTRY_ID (BIGINT)
	DSNPXH03	STARTTS (TIMESTAMP)
SYSAUTORUNS_HISTOU	DSNPXH04 (A)	OUTPUT (CLOB(2M))
SYSAUTOTIMEWINDOWS	DSNTWX01 (UC)	WINDOW_ID (BIGINT)
SYSAUXRELS	DSNOXX01 (NC)	TBOWNER (VARCHAR(128)) TBNAME (VARCHAR(128))
	DSNOXX02 (N)	AUXTBOWNER (VARCHAR(128)) AUXTBNAME (VARCHAR(128))
SYSCHECKDEP	DSNSDX01 (UC)	TBOWNER (VARCHAR(128)) TBNAME (VARCHAR(128)) CHECKNAME (VARCHAR(128)) COLNAME (VARCHAR(128))
SYSCHECKS	DSNSCX01 (UC)	TBOWNER (VARCHAR(128)) TBNAME (VARCHAR(128)) CHECKNAME (VARCHAR(128))
SYSCHECKS2	DSNCHX01 (UC)	TBOWNER (VARCHAR(128)) TBNAME (VARCHAR(128)) CHECKNAME (VARCHAR(128))
SYSCOLAUTH	DSNACX01 (N)	CREATOR (VARCHAR(128)) TNAME (VARCHAR(128)) COLNAME (VARCHAR(128))
	DSNACX02 (N)	CREATOR (VARCHAR(128)) TNAME (VARCHAR(128)) TIMESTAMP (TIMESTAMP)
	DSNACX03 (N)	GRANTOR (VARCHAR(128)) GRANTORTYPE (CHAR(1)) CREATOR (VARCHAR(128)) TNAME (VARCHAR(128)) TIMESTAMP (CHAR(12))

Table 386. Indexes on Db2 catalog tables (continued)

Table	Index (type "1" on page 2767)	Columns (data type)
	DSNACX04 (N)	GRANTEE (VARCHAR(128)) GRANTEETYPE (CHAR(1)) CREATOR (VARCHAR(128)) TNAME (VARCHAR(128)) TIMESTAMP (CHAR(12))
SYSCOLDIST	DSNTNX01 (NC)	TBOWNER (VARCHAR(128)) TBNAME (VARCHAR(128)) NAME (VARCHAR(128))
SYSCOLDISTSTATS	DSNTPX01 (NC)	TBOWNER (VARCHAR(128)) TBNAME (VARCHAR(128)) NAME (VARCHAR(128)) PARTITION (SMALLINT)
SYSCOLDIST_HIST	DSNHFX01 (N)	TBOWNER (VARCHAR(128)) TBNAME (VARCHAR(128)) NAME (VARCHAR(128)) STATTIME (TIMESTAMP)
SYSCOLSTATS	DSNTCX01 (NC)	TBOWNER (VARCHAR(128)) TBNAME (VARCHAR(128)) NAME (VARCHAR(128)) PARTITION (SMALLINT)
SYSCOLUMNS	DSNDCX01 (U)	TBCREATOR (VARCHAR(128)) TBNAME (VARCHAR(128)) NAME (VARCHAR(128))
	DSNDCX02 (N)	TYPESHEMA (VARCHAR(128)) TYPENAME (VARCHAR(128))
	DSNDCX05 (N)	TBCREATOR (VARCHAR(128)) TBNAME (VARCHAR(128))
	DSNDCX06 (N)	TBCREATOR (VARCHAR(128)) TBNAME (VARCHAR(128)) COLNO (SMALLINT)
SYSCOLUMNS_HIST	DSNHEX01 (N)	TBCREATOR (VARCHAR(128)) TBNAME (VARCHAR(128)) NAME (VARCHAR(128)) STATTIME (TIMESTAMP)
SYSCONSTDEP	DSNCCX01 (N)	BSHEMA (VARCHAR(128)) BNAME (VARCHAR(128)) BTYPE (CHAR(1))

Table 386. Indexes on Db2 catalog tables (continued)

Table	Index (type "1" on page 2767)	Columns (data type)
	DSNCCX02 (N)	DTBSHEMA (VARCHAR(128)) DTBNAME (VARCHAR(128))
SYSCONTEXT	DSNCTX01 (UC)	NAME (VARCHAR(128))
	DSNCTX02 (U)	SYSTEMAUTHID (VARCHAR(128))
	DSNCTX03 (U)	CONTEXTID (INTEGER)
	DSNCTX04 (N)	DEFAULTROLE (VARCHAR(128))
SYSCONTEXTAUTHIDS	DSNCDX01 (UC)	CONTEXTID (INTEGER) AUTHID (VARCHAR(128))
	DSNCDX02 (N)	ROLE (VARCHAR(128))
SYSCONTROLS	DSNCLX01 (U)	SCHEMA (VARCHAR(128)) NAME (VARCHAR(128))
	DSNCLX02 (U)	CONTROL_ID (INTEGER)
	DSNCLX03 (N)	TBSHEMA (VARCHAR(128)) TBNAME (VARCHAR(128))
	DSNCLX04 (N)	TBSHEMA (VARCHAR(128)) TBNAME (VARCHAR(128)) ENABLE (CHAR(1))
	DSNCLX05 (N)	TBSHEMA (VARCHAR(128)) TBNAME (VARCHAR(128)) ENABLE (CHAR(1)) CONTROL_TYPE (CHAR(1))
SYSCONTROLS_DESC	DSNTRX02 (A)	DESCRIPTOR (BLOB(2M))
SYSCONTROLS_DESC_H	DSNTRX04 (A)	DESCRIPTOR (BLOB(2M))
SYSCONTROLS_RTXT	DSNTRX01 (A)	RULETEXT (CLOB(2M))
SYSCONTROLS_RTXT_H	DSNTRX03 (A)	RULETEXT (CLOB(2M))

Table 386. Indexes on Db2 catalog tables (continued)

Table	Index (type "1" on page 2767)	Columns (data type)
SYSCOPY	DSNUCH01 (N)	DBNAME (CHAR(8)) TSNAME (CHAR(8)) START_RBA (CHAR(6)) TIMESTAMP (TIMESTAMP)
	DSNUCX01 (U)	DSNAME (CHAR(44))
SYSCTXTTRUSTATTRS	DSNCAX01 (UC)	CONTEXTID (INTEGER) NAME (VARCHAR(128)) VALUE (VARCHAR(256))
SYSDATABASE	DSNDDH01 (U)	NAME (VARCHAR(24))
	DSNDDX02 (N)	GROUP_MEMBER (VARCHAR(24))
SYSDATATYPES	DSNODX01 (U)	SCHEMA (VARCHAR(128)) NAME (VARCHAR(128))
	DSNODX02 (U)	DATATYPEID (INTEGER)
SYSDBAUTH	DSNADH01 (N)	GRANTEE (VARCHAR(128)) NAME (VARCHAR(24)) GRANTEETYPE (CHAR(1))
	DSNADX01 (N)	GRANTOR (VARCHAR(128)) NAME (VARCHAR(24)) GRANTORTYPE (CHAR(1))
	DSNADH02 (N)	NAME (VARCHAR(24))
SYSDBRM	DSNDBX01 (N)	PLNAME (VARCHAR(24))
	DSNDBX02 (U)	PLNAME (VARCHAR(24)) NAME (VARCHAR(24))
SYSDEPENDENCIES	DSNONX01 (U)	BSHEMA (VARCHAR(128)) BNAME (VARCHAR(128)) BTYPE (CHAR(1)) BCOLNAME (VARCHAR(128))
	DSNONX02 (N)	DSHEMA (VARCHAR(128)) DNAME (VARCHAR(128)) DTYPE (CHAR(1)) DCOLNAME (VARCHAR(128))

Table 386. Indexes on Db2 catalog tables (continued)

Table	Index (type "1" on page 2767)	Columns (data type)
SYSDYNQRY	DSNDQX01 (PU)	SDQ_STMT_ID (BIGINT) COPYID (SMALLINT)
	DSNDQX02 (N)	SCHEMA CURSCHEMA (VARCHAR(128)) QUERY_HASH (CHAR(16)) COPYID (SMALLINT) RELBOUND (CHAR(1))
SYSDYNQRYDEP	DSNDQX11 (U)	STBLGRP (VARCHAR(128)) SDQ_STMT_ID (BIGINT) COPYID (SMALLINT)
	DSNDQX03 (N)	SDQ_STMT_ID (BIGINT) COPYID (SMALLINT)
	DSNDQX04 (N)	BQUALIFIER (VARCHAR(128)) BNAME (VARCHAR(128)) BTYPE (CHAR(1)) SDQ_STMT_ID (BIGINT) COPYID (SMALLINT)
	DSNDQX05 (N)	CLASS (CHAR(1)) AUTHID (VARCHAR(128)) AUTHID_TYPE (CHAR(1))
	DSNDQX12 (N)	CLASS (CHAR(1)) BTYPE (CHAR(1)) BAUTH (SMALLINT) AUTHID_TYPE (CHAR(1)) AUTHID (VARCHAR(128)) BQUALIFIER (VARCHAR(128)) BNAME (VARCHAR(128))
SYSDYNQRY_EXPL	DSNDQX08 (A)	DATA2 (BLOB(2147483647))
SYSDYNQRY_OPL	DSNDQX10 (A)	DATA4 (BLOB(2147483647))
SYSDYNQRY_SHTEL	DSNDQX09 (A)	DATA3 (BLOB(2147483647))
SYSDYNQRY_SPAL	DSNDQX07 (A)	DATA1 (BLOB(2147483647))
SYSDYNQRY_TXTL	DSNDQX06 (A)	STMTTEXT (CLOB(2M))
SYSENVIRONMENT	DSNOEX01 (U)	ENVID (INTEGER)

Table 386. Indexes on Db2 catalog tables (continued)

Table	Index (type "1" on page 2767)	Columns (data type)
SYSFIELDS	DSNDFX01 (N)	TBCREATOR (VARCHAR(128)) TBNAME (VARCHAR(128)) NAME (VARCHAR(128))
SYSFOREIGNKEYS	DSNDRH01 (N)	CREATOR (VARCHAR(128)) TBNAME (VARCHAR(128)) RELNAME (VARCHAR(128))
SYSINDEXCLEANUP	DSNICX01 (N)	DBNAME (VARCHAR(24)) INDEXSPACE (VARCHAR(24))
SYSINDEXES	DSNDXX01 (U)	CREATOR (VARCHAR(128)) NAME (VARCHAR(128))
	DSNDXX02 (U)	DBNAME (VARCHAR(24)) INDEXSPACE (VARCHAR(24))
	DSNDXX03 (U)	TBCREATOR (VARCHAR(128)) TBNAME (VARCHAR(128)) CREATOR (VARCHAR(128)) NAME (VARCHAR(128))
	DSNDXX04 (N)	INDEXTYPE (CHAR(1))
SYSINDEXES_HIST	DSNDXX07 (N)	TBCREATOR (VARCHAR(128)) TBNAME (VARCHAR(128))
	DSNHHX01 (NC)	TBCREATOR (VARCHAR(128)) TBNAME (VARCHAR(128)) NAME (VARCHAR(128)) STATSTIME (TIMESTAMP)
	DSNHHX02 (N)	CREATOR (VARCHAR(128)) NAME (VARCHAR(128))
SYSINDEXES_RTSECT	DSNDXX06 (A)	RTSECTION (BLOB(1G))
SYSINDEXES_TREE	DSNDXX05 (A)	PARSETREE (BLOB(1G))
SYSINDEXPART	DSNDRX01 (U)	IXCREATOR (VARCHAR(128)) IXNAME (VARCHAR(128)) PARTITION (SMALLINT)
	DSNDRX02 (N)	STORNAME (VARCHAR(128))

Table 386. Indexes on Db2 catalog tables (continued)

Table	Index (type "1" on page 2767)	Columns (data type)
	DSNDRX03 (N)	IXCREATOR (VARCHAR(128)) IXNAME (VARCHAR(128))
SYSINDEXPART_HIST	DSNHGX01 (N)	IXCREATOR (VARCHAR(128)) IXNAME (VARCHAR(128)) PARTITION (SMALLINT) STATSTIME (TIMESTAMP)
SYSINDEXSPACESTATS	DSNRTX02 (U)	DBID (SMALLINT) ISOBID (SMALLINT) PARTITION (SMALLINT) INSTANCE (SMALLINT)
	DSNRTX03 (N)	CREATOR (VARCHAR(128)) NAME (VARCHAR(128))
SYSINDEXSTATS	DSNTXX01 (UC)	OWNER (VARCHAR(128)) NAME (VARCHAR(128)) PARTITION (SMALLINT)
SYSINDEXSTATS_HIST	DSNHIX01 (NC)	IXCREATOR (VARCHAR(128)) IXNAME (VARCHAR(128)) PARTITION (SMALLINT) STATSTIME (TIMESTAMP)
SYSJARDATA	DSNJDX01 (A)	JARDATA (BLOB(100M))
SYSJARCLASS_SOURCE	DSNJSX01 (A)	CLASS_SOURCE (CLOB(10M))
SYSJARCONTENTS	DSNJCX01 (NC)	JARSCHEMA (VARCHAR(128)) JAR_ID (VARCHAR(128))
SYSJAROBJECTS	DSNJOX01 (UC)	JARSCHEMA (VARCHAR(128)) JAR_ID (VARCHAR(128))
SYSJAVA_OPTS	DSNJVX01 (UC)	JARSCHEMA (VARCHAR(128)) JAR_ID (VARCHAR(128))
SYSJAVAPATHS	DSNJPX01 (U)	JARSCHEMA (VARCHAR(128)) JAR_ID (VARCHAR(128)) ORDINAL (SMALLINT)
	DSNJPX02 (N)	PE_JARSCHEMA (VARCHAR(128)) PE_JAR_ID (VARCHAR(128))

Table 386. Indexes on Db2 catalog tables (continued)

Table	Index (type "1" on page 2767)	Columns (data type)
SYSKEYCOLUSE	DSNCUX01 (N)	TBCREATOR (VARCHAR(128)) TBNAME (VARCHAR(128)) CONSTNAME (VARCHAR(128)) COLSEQ (SMALLINT)
SYSKEYS	DSNDKX01 (U)	IXCREATOR (VARCHAR(128)) IXNAME (VARCHAR(128)) COLNAME (VARCHAR(128))
	DSNDKX02 (N)	IXCREATOR (VARCHAR(128)) IXNAME (VARCHAR(128))
	DSNDKX03 (U)	IXCREATOR (VARCHAR(128)) IXNAME (VARCHAR(128)) COLSEQ (SMALLINT)
SYSKEYTARGETS	DSNRKX01 (UC)	IXSCHEMA (VARCHAR(128)) IXNAME (VARCHAR(128)) KEYSEQ (SMALLINT)
	DSNRKX02 (N)	DATATYPEID (INTEGER) KEYSPEC_INTERNAL (VARCHAR(512))
SYSKEYTARGETSTATS	DSNTKX01 (U)	IXSCHEMA (VARCHAR(128)) IXNAME (VARCHAR(128)) KEYSEQ (SMALLINT) PARTITION (SMALLINT)
SYSKEYTARGETS_HIST	DSNHKX01 (N)	IXSCHEMA (VARCHAR(128)) IXNAME (VARCHAR(128)) KEYSEQ (SMALLINT) STATSTIME (TIMESTAMP)
SYSKEYTGTDIST	DSNTDX01 (N)	IXSCHEMA (VARCHAR(128)) IXNAME (VARCHAR(128)) KEYSEQ (SMALLINT)
SYSKEYTGTDISTSTATS	DSNTSX01 (N)	IXSCHEMA (VARCHAR(128)) IXNAME (VARCHAR(128)) KEYSEQ (SMALLINT) PARTITION (SMALLINT)
SYSKEYTGTDIST_HIST	DSNTDX02 (N)	IXSCHEMA (VARCHAR(128)) IXNAME (VARCHAR(128)) KEYSEQ (SMALLINT) STATSTIME (TIMESTAMP)

Table 386. Indexes on Db2 catalog tables (continued)

Table	Index (type "1" on page 2767)	Columns (data type)
SYSLOBSTATS	DSNLNX01 (UC)	DBNAME (VARCHAR(24)) NAME (VARCHAR(24))
SYSLEVELSUPDATED	DSNLVX01 (N)	OPERATION_TYPE (CHAR(1)), EFFECTIVE_TIME (TIMESTAMP(12))
	DSNLVX02 (N)	EFFECTIVE TIME (TIMESTAMP(12))
SYSLOBSTATS_HIST	DSNHJX01 (NC)	DBNAME (CHAR(8)) NAME (CHAR(8)) STATSTIME (TIMESTAMP)
SYSOBDS	DSNDOB01 (N)	CREATOR (VARCHAR(128)) NAME (VARCHAR(128)) OBDTYPE (CHAR(1))
	DSNDOB02 (N)	CREATOR (VARCHAR(128)) NAME (VARCHAR(128)) OBDTYPE (CHAR(1))
SYSOBD_AUX	DSNOB03 (A)	OBD_IMAGE (BLOB(1G))
SYSOBJROLEDEP	DSNRDX01 (UC)	DSCHEMA (VARCHAR(128)) DNAME (VARCHAR(128)) DTYPE (CHAR(1))
	DSNRDX02 (N)	ROLENAME (VARCHAR(128))
SYSPACKAUTH	DSNKAX01 (N)	GRANTOR (VARCHAR(128)) LOCATION (VARCHAR(128)) COLLID (VARCHAR(128)) NAME (VARCHAR(128)) GRANTORTYPE (CHAR(1))
	DSNKAX02 (N)	GRANTEE (VARCHAR(128)) LOCATION (VARCHAR(128)) COLLID (VARCHAR(128)) NAME (VARCHAR(128)) BINDAUTH (CHAR(1)) COPYAUTH (CHAR(1)) EXECUTEAUTH (CHAR(1)) GRANTEETYPE (CHAR(1))
	DSNKAX03 (N)	LOCATION (VARCHAR(128)) COLLID (VARCHAR(128)) NAME (VARCHAR(128))

Table 386. Indexes on Db2 catalog tables (continued)

Table	Index (type "1" on page 2767)	Columns (data type)
SYSPACKAGE	DSNKKX01 (U)	LOCATION (VARCHAR(128)) COLLID (VARCHAR(128)) NAME (VARCHAR(128)) VERSION (VARCHAR(122))
	DSNKKX02 (U)	LOCATION (VARCHAR(128)) COLLID (VARCHAR(128)) NAME (VARCHAR(128)) CONTOKEN (CHAR(8))
SYSPACKCOPY	DSNPCX01 (UC)	LOCATION (VARCHAR(128)) COLLID (VARCHAR(128)) NAME (VARCHAR(128)) CONTOKEN (CHAR(8)) COPYID (INTEGER)
SYSPACKDEP	DSNKDX01 (N)	DLOCATION (VARCHAR(128)) DCOLLID (VARCHAR(128)) DNAME (VARCHAR(128)) DCONTOKEN (CHAR(8))
	DSNKDX02 (N)	BQUALIFIER (VARCHAR(128)) BNAME (VARCHAR(128)) BTYPE (CHAR(1))
	DSNKDX03 (N)	BQUALIFIER (VARCHAR(128)) BNAME (VARCHAR(128)) BTYPE (CHAR(1)) DTYPE (CHAR(1))
SYSPACKLIST	DSNKLX01 (N)	LOCATION (VARCHAR(128)) COLLID (VARCHAR(128)) NAME (VARCHAR(128))
	DSNKLX02 (U)	PLANNAME (VARCHAR(24)) SEQNO (SMALLINT) LOCATION (VARCHAR(128)) COLLID (VARCHAR(128)) NAME (VARCHAR(128))
SYSPACKSTMT	DSNKSX01 (UC)	LOCATION (VARCHAR(128)) COLLID (VARCHAR(128)) NAME (VARCHAR(128)) CONTOKEN (CHAR(8)) SEQNO (INTEGER)
SYSPACKSTMT_STMB	DSNKSX02 (A)	STMTBLOB (BLOB(2M))

Table 386. Indexes on Db2 catalog tables (continued)

Table	Index (type "1" on page 2767)	Columns (data type)
SYSPACKSTMT_STMT	DSNPX01 (A)	STATEMENT (CLOB(2M))
SYSPARMS	DSNOPX01 (U)	SCHEMA (VARCHAR(128)) SPECIFICNAME (VARCHAR(128)) ROUTINETYPE (CHAR(1)) ROWTYPE (CHAR(1)) ORDINAL (SMALLINT) VERSION (VARCHAR(122))
	DSNOPX02 (N)	TYPESCHEMA (VARCHAR(128)) TYPENAME (VARCHAR(128)) ROUTINETYPE (CHAR(1)) CAST_FUNCTION (CHAR(1)) OWNER (VARCHAR(128)) SCHEMA (VARCHAR(128)) SPECIFICNAME (VARCHAR(128))
	DSNOPX03 (N)	TYPESCHEMA (VARCHAR(128)) TYPENAME (VARCHAR(128))
	DSNOPX04 (N)	SCHEMA (VARCHAR(128)) SPECIFICNAME (VARCHAR(128)) ROUTINETYPE (CHAR(1)) VERSION (VARCHAR(122))
SYSPENDINGDDL	DSNPDX01 (N)	DBNAME (VARCHAR(24)) TSNAME (VARCHAR(24)) CREATEDTS (TIMESTAMP) OPTION_SEQNO (SMALLINT)
	DSNPDX02 (N)	OBJSHEMA (VARCHAR(128)) OBJNAME (VARCHAR(128)) OBJTYPE (CHAR(1)) CREATEDTS (TIMESTAMP) OPTION_SEQNO (SMALLINT)
SYSPENDINGDDLTEXT	DSNPDX03 (A)	STATEMENT_TEXT (CLOB(2M))
SYSPENDINGOBJECTS	DSNPOX01 (N)	DBNAME (VARCHAR(24)) TSNAME (VARCHAR(24)) PARTITION (SMALLINT) COLNAME (VARCHAR(128))
	DSNPOX02 (N)	OBJSHEMA (VARCHAR(128)) OBJNAME (VARCHAR(128)) OBJTYPE (CHAR(1))

Table 386. Indexes on Db2 catalog tables (continued)

Table	Index (type "1" on page 2767)	Columns (data type)
	DSNPOX03 (N)	DBNAME (VARCHAR(24)) INDEXSPACE (CHAR(8))
SYSPKSYSTEM	DSNKYX01 (N)	LOCATION (VARCHAR(128)) COLLID (VARCHAR(128)) NAME (VARCHAR(128)) CONTOKEN (CHAR(8)) SYSTEM (VARCHAR(24)) ENABLE (CHAR(1))
SYSPLAN	DSNPPH01 (U)	NAME (VARCHAR(24))
SYSPLANAUTH	DSNAPH01 (N)	GRANTEE (VARCHAR(128)) NAME (VARCHAR(24)) EXECUTEAUTH (CHAR(1)) GRANTEETYPE (CHAR(1))
	DSNAPX01 (N)	GRANTOR (VARCHAR(128)) GRANTORTYPE (CHAR(1))
	DSNAPX02 (N)	NAME (VARCHAR(24))
SYSPLANDEP	DSNGGX01 (N)	BCREATOR (VARCHAR(128)) BNAME (VARCHAR(128)) BTYPE (CHAR(1))
	DSNGGX05 (N)	DNAME (VARCHAR(24))
SYSPLSYSTEM	DSNKPX01 (N)	NAME (VARCHAR(24)) SYSTEM (VARCHAR(24)) ENABLE (CHAR(1))
SYSPROFILE_TEXT	DSNPRX02 (A)	PROFILE_TEXT (CLOB(1M))
SYSQUERY	DSNQYX01 (N)	QUERY_HASH (CHAR(16)) SCHEMA (VARCHAR(128)) SOURCE (SMALLINT) QUERY_SEC_HASH (CHAR(16))
	DSNQYX02 (U)	QUERYID (BIGINT)
	DSNQYX03 (N)	LOCATION (VARCHAR(128)) COLLECTION (VARCHAR(128)) PACKAGE (VARCHAR(128)) VERSION (VARCHAR(128)) SECTNO (INTEGER)

Table 386. Indexes on Db2 catalog tables (continued)

Table	Index (type "1" on page 2767)	Columns (data type)
	DSNQYX04 (N)	QUERY_SEC_HASH (CHAR(16)) SCHEMA (VARCHAR(128)) SOURCE (SMALLINT)
SYSQUERYPRDICTATE	DSNQEX01 (UC)	QUERYID (BIGINT) PREDNO (INTEGER)
	DSNQEX02 (N)	QUERYID (BIGINT)
SYSQUERYOPTS	DSNQPX01 (N)	QUERYID (BIGINT) COPYID (SMALLINT)
SYSQUERYPLAN	DSNQNX01 (N)	QUERYID (BIGINT) COPYID (SMALLINT)
SYSQUERYSEL	DSNQLX01 (PU)	QUERYID (BIGINT) PREDNO (INTEGER) INSTANCE (SMALLINT)
	DSNQLX02 (N)	QUERYID (BIGINT) PREDNO (INTEGER)
SYSQUERY_AUX	DSNQSX01 (A)	STMTTEXT (CLOB(2M))
SYSRELS	DSNDLX01 (N)	REFTBCREATOR (VARCHAR(128)) REFTBNAME (VARCHAR(128))
	DSNDLX02 (N)	CREATOR (VARCHAR(128)) TBNAME (VARCHAR(128))
	DSNDLX03 (N)	IXOWNER (VARCHAR(128)) IXNAME (VARCHAR(128))
	DSNDLX04 (U)	CREATOR (VARCHAR(128)) TBNAME (VARCHAR(128)) RELNAME (VARCHAR(128))
SYSRESAUTH	DSNAGH01 (N)	GRANTEE (VARCHAR(128)) QUALIFIER (VARCHAR(128)) NAME (VARCHAR(128)) OBTYP (CHAR(1)) GRANTEETYPE (CHAR(1))

Table 386. Indexes on Db2 catalog tables (continued)

Table	Index (type "1" on page 2767)	Columns (data type)
	DSNAGX01 (N)	GRANTOR (VARCHAR(128)) QUALIFIER (VARCHAR(128)) NAME (VARCHAR(128)) OBTYPE (CHAR(1)) GRANTORTYPE (CHAR(1))
SYSROLES	DSNRLX01 (UC)	NAME (VARCHAR(128))
SYSROUTINEAUTH	DSNOAX01 (N)	GRANTOR (VARCHAR(128)) SCHEMA (VARCHAR(128)) SPECIFICNAME (VARCHAR(128)) ROUTINETYPE (CHAR(1)) GRANTEETYPE (CHAR(1)) EXECUTEAUTH (CHAR(1)) GRANTORTYPE (CHAR(1))
	DSNOAX02 (U)	GRANTEE (VARCHAR(128)) SCHEMA (VARCHAR(128)) SPECIFICNAME (VARCHAR(128)) ROUTINETYPE (CHAR(1)) GRANTEETYPE (CHAR(1)) EXECUTEAUTH (CHAR(1)) GRANTEDTS (TIMESTAMP)
	DSNOAX03 (N)	SCHEMA (VARCHAR(128)) SPECIFICNAME (VARCHAR(128)) ROUTINETYPE (CHAR(1))

Table 386. Indexes on Db2 catalog tables (continued)

Table	Index (type "1" on page 2767)	Columns (data type)
SYSROUTINES	DSNOFX01 (UC)	NAME (VARCHAR(128)) PARM_COUNT (SMALLINT) PARM_SIGNATURE (VARCHAR(150)) ROUTINETYPE (CHAR(1)) SCHEMA (VARCHAR(128)) PARM1 (SMALLINT) PARM2 (SMALLINT) PARM3 (SMALLINT) PARM4 (SMALLINT) PARM5 (SMALLINT) PARM6 (SMALLINT) PARM7 (SMALLINT) PARM8 (SMALLINT) PARM9 (SMALLINT) PARM10 (SMALLINT) PARM11 (SMALLINT) PARM12 (SMALLINT) PARM13 (SMALLINT) PARM14 (SMALLINT) PARM15 (SMALLINT) PARM16 (SMALLINT) PARM17 (SMALLINT) PARM18 (SMALLINT) PARM19 (SMALLINT) PARM20 (SMALLINT) PARM21 (SMALLINT) PARM22 (SMALLINT) PARM23 (SMALLINT) PARM24 (SMALLINT) PARM25 (SMALLINT) PARM26 (SMALLINT) PARM27 (SMALLINT) PARM28 (SMALLINT) PARM29 (SMALLINT) PARM30 (SMALLINT) VERSION (VARCHAR(122))
	DSNOFX02 (PU)	SCHEMA (VARCHAR(128)) SPECIFICNAME (VARCHAR(128)) ROUTINETYPE (CHAR(1)) VERSION (VARCHAR(122))
	DSNOFX03 (N)	NAME (VARCHAR(128)) SCHEMA (VARCHAR(128)) CAST_FUNCTION (CHAR(1)) PARM_COUNT (SMALLINT) PARM_SIGNATURE (VARCHAR(150)) PARM1 (SMALLINT)
	DSNOFX04 (U)	ROUTINE_ID (INTEGER)

Table 386. Indexes on Db2 catalog tables (continued)

Table	Index (type "1" on page 2767)	Columns (data type)
	DSNOFX05 (N)	SOURCESCHEMA (VARCHAR(128)) SOURCESPECIFIC (VARCHAR(128)) ROUTINETYPE (CHAR(1))
	DSNOFX06 (N)	SCHEMA (VARCHAR(128)) NAME (VARCHAR(128)) ROUTINETYPE (CHAR(1)) PARAM_COUNT (SMALLINT)
	DSNOFX07 (U)	NAME (VARCHAR(128)) PARAM_COUNT (SMALLINT) ROUTINETYPE (CHAR(1)) SCHEMA (VARCHAR(128)) PARAM_SIGNATURE (VARCHAR(150)) PARAM1 (SMALLINT) PARAM2 (SMALLINT) PARAM3 (SMALLINT) PARAM4 (SMALLINT) PARAM5 (SMALLINT) PARAM6 (SMALLINT) PARAM7 (SMALLINT) PARAM8 (SMALLINT) PARAM9 (SMALLINT) PARAM10 (SMALLINT) PARAM11 (SMALLINT) PARAM12 (SMALLINT) PARAM13 (SMALLINT) PARAM14 (SMALLINT) PARAM15 (SMALLINT) PARAM16 (SMALLINT) PARAM17 (SMALLINT) PARAM18 (SMALLINT) PARAM19 (SMALLINT) PARAM20 (SMALLINT) PARAM21 (SMALLINT) PARAM22 (SMALLINT) PARAM23 (SMALLINT) PARAM24 (SMALLINT) PARAM25 (SMALLINT) PARAM26 (SMALLINT) PARAM27 (SMALLINT) PARAM28 (SMALLINT) PARAM29 (SMALLINT) PARAM30 (SMALLINT) VERSION (VARCHAR(122))
	DSNOFX08 (N)	JARSCHEMA (VARCHAR(128)) JAR_ID (VARCHAR(128))
SYSROUTINESTEXT	DSNPLX01 (A)	TEXT (CLOB(2M))

Table 386. Indexes on Db2 catalog tables (continued)

Table	Index (type "1" on page 2767)	Columns (data type)
SYSROUTINES_OPTS	DSNROX01 (UC)	SCHEMA (VARCHAR(128)) ROUTINENAME (VARCHAR(128)) BUILDDATE (DATE) BUILDTIME (TIME)
SYSROUTINES_SRC	DSNRSX01 (N)	ROUTINENAME (VARCHAR(128))
	DSNRSX02 (UC)	SCHEMA (VARCHAR(128)) ROUTINENAME (VARCHAR(128)) BUILDDATE (DATE) SEQNO (INTEGER)
SYSROUTINES_TREE	DSNPLX02 (A)	PTREE (BLOB(1G))
SYSSCHEMAAUTH	DSNSKX01 (N)	GRANTEE (VARCHAR(128)) SCHEMANAME (VARCHAR(128)) GRANTEETYPE (CHAR(1))
	DSNSKX02 (N)	GRANTOR (VARCHAR(128)) GRANTORTYPE (CHAR(1))
SYSSEQUENCEAUTH	DSNWCX01 (N)	SCHEMA (VARCHAR(128)) NAME (VARCHAR(128))
	DSNWCX02 (N)	GRANTOR (VARCHAR(128)) SCHEMA (VARCHAR(128)) NAME (VARCHAR(128)) GRANTORTYPE (VARCHAR(128))
	DSNWCX03 (N)	GRANTEE (VARCHAR(128)) SCHEMA (VARCHAR(128)) NAME (VARCHAR(128)) GRANTEETYPE (VARCHAR(128))
SYSSEQUENCES	DSNSQX01 (U)	SCHEMA (VARCHAR(128)) NAME (VARCHAR(128))
	DSNSQX02 (UD)	SEQUENCEID (INTEGER)
	DSNSQX03 (N)	SEQSCHEMA (VARCHAR(128)) SEQNAME (VARCHAR(128))
SYSSEQUENCESDEP	DSNSRX01 (N)	DCREATOR (VARCHAR(128)) DNAME (VARCHAR(128)) DCOLNAME (VARCHAR(128))

Table 386. Indexes on Db2 catalog tables (continued)

Table	Index (type "1" on page 2767)	Columns (data type)
	DSNSRX02 (N)	BSCHEMA (VARCHAR(128)) BNAME (VARCHAR(128)) DTYPE (CHAR(1))
SYSSSESSION	DSNSNX02 (PU)	TOKEN (CHAR(40))
SYSSSESSION_DATA	DSNSNX03 (A)	DATA (BLOB(2147483647))
SYSSSESSION_EX	DSNSNX04 (N)	TOKEN (CHAR(40))
	DSNSNX05 (U)	TOKEN (CHAR(40)) GVID (CHAR(8)) LOCATOR (CHAR(8))
SYSSSESSION_GV	DSNSNX01 (A)	GLOBAL_VARIABLES (BLOB(2147483647)))
SYSSSESSION_STATUS	DSNSNX06 (U)	TOKEN (CHAR(40))
SYSSTATFEEDBACK	DSNSFX01 (N)	TBCREATOR (VARCHAR(128)) TBNAME (VARCHAR(128)) IXCREATOR (VARCHAR(128)) IXNAME (VARCHAR(128)) COLNAME (VARCHAR(128)) COLGROUPNO (VARCHAR(254)) NUMCOLUMNS (SMALLINT) TYPE (CHAR(1))
	DSNSFX02 (N)	TBCREATOR (VARCHAR(128)) TBNAME (VARCHAR(128))
	DSNSFX03 (N)	IXCREATOR (VARCHAR(128)) IXNAME (VARCHAR(128))
SYSSTOGROUP	DSNSSH01 (U)	NAME (VARCHAR(128))
SYSSTMT	DSNPSX01 (N)	PLNAME (VARCHAR(24)) NAME (VARCHAR(24))
	DSNPSX02 (N)	PLNAME (VARCHAR(24)) NAME (VARCHAR(24)) SEQNO (INTEGER)
SYSSTRINGS	DSNSSX01 (U)	OUTCCSID (INTEGER) INCCSID (INTEGER) IBMREQD (CHAR(1))

Table 386. Indexes on Db2 catalog tables (continued)

Table	Index (type "1" on page 2767)	Columns (data type)
SYSSYNONYMS	DSNDYX01 (U)	CREATOR (VARCHAR(128)) NAME (VARCHAR(128))
	DSNDYX02 (N)	TBCREATOR (VARCHAR(128)) TBNAME (VARCHAR(128))
SYSTABAUTH	DSNATX01 (N)	GRANTOR (VARCHAR(128)) GRANTORTYPE (CHAR(1))
	DSNATX02 (N)	GRANTEE (VARCHAR(128)) TCREATOR (VARCHAR(128)) TTNAME (VARCHAR(128)) GRANTEETYPE (CHAR(1)) UPDATECOLS (CHAR(1)) ALTERAUTH (CHAR(1)) DELETEAUTH (CHAR(1)) INDEXAUTH (CHAR(1)) INSERTAUTH (CHAR(1)) SELECTAUTH (CHAR(1)) UPDATEAUTH (CHAR(1)) CAPTUREAUTH (CHAR(1)) REFERENCESAUTH (CHAR(1)) REFCOLS (CHAR(1)) TRIGGERAUTH (CHAR(1)) UNLOADAUTH (CHAR(1))
	DSNATX03 (N)	GRANTEE (VARCHAR(128)) GRANTEETYPE (CHAR(1)) COLLID (VARCHAR(128)) CONTOKEN (CHAR(8))
	DSNATX04 (N)	TCREATOR (VARCHAR(128)) TTNAME (VARCHAR(8))
	DSNATX05 (PU)	TCREATOR (VARCHAR(128)) TTNAME (VARCHAR(128)) TIMESTAMP (CHAR(12))
SYSTABCONST	DSNCNX01 (U)	TBCREATOR (VARCHAR(128)) TBNAME (VARCHAR(128)) CONSTNAME (VARCHAR(128))
	DSNCNX02 (N)	IXOWNER (VARCHAR(128)) IXNAME (VARCHAR(128))
SYSTABLEPART	DSNDPX01 (U)	DBNAME (VARCHAR(24)) TSNAME (VARCHAR(24)) PARTITION (SMALLINT)

Table 386. Indexes on Db2 catalog tables (continued)

Table	Index (type "1" on page 2767)	Columns (data type)
	DSNDPX02 (N)	STORNAME (VARCHAR(128))
	DSNDPX03 (N)	DBNAME (VARCHAR(24)) TSNAME (VARCHAR(24)) LOGICAL_PART (SMALLINT)
	DSNDPX04 (N)	IXCREATOR (VARCHAR(128)) IXNAME (VARCHAR(128))
	DSNDPX05 (N)	DBNAME (VARCHAR(24)) TSNAME (VARCHAR(24))
SYSTABLEPART_HIST	DSNHXC01 (N)	DBNAME (CHAR(8)) TSNAME (CHAR(8)) PARTITION (SMALLINT) STATTIME (TIMESTAMP)
SYSTABLES	DSNDTX01 (PU)	CREATOR (VARCHAR(128)) NAME (VARCHAR(128))
	DSNDTX02 (U)	DBID (SMALLINT) OBID (SMALLINT) CREATOR (VARCHAR(128)) NAME (VARCHAR(128))
	DSNDTX03 (N)	TBCREATOR (VARCHAR(128)) TBNAME (VARCHAR(128))
	DSNDTX05 (N)	DBNAME (VARCHAR(24)) TSNAME (VARCHAR(24))
SYSTABLESPACE	DSNDSX01 (U)	DBNAME (VARCHAR(24)) NAME (VARCHAR(24))
SYSTABLESPACESTATS	DSNRTX01 (U)	DBID (SMALLINT) PSID (SMALLINT) PARTITION (SMALLINT) INSTANCE (SMALLINT)
SYSTABLES_HIST	DSNHDX01 (N)	CREATOR (VARCHAR(128)) NAME (VARCHAR(128)) STATTIME (TIMESTAMP)
SYSTABLES_PROFILES	DSNPRX01 (UC)	SCHEMA (VARCHAR(128)) TBNAME (VARCHAR(128)) PROFILE_TYPE (VARCHAR(32))

Table 386. Indexes on Db2 catalog tables (continued)

Table	Index (type "1" on page 2767)	Columns (data type)
SYSTABSTATS	DSNTTX01 (U)	OWNER (VARCHAR(128)) NAME (VARCHAR(128)) PARTITION (SMALLINT)
	DSNTTX02 (N)	DBNAME (VARCHAR(24)) NAME (VARCHAR(128))
SYSTABSTATS_HIST	DSNHXB01 (NC)	OWNER (VARCHAR(128)) NAME (VARCHAR(128)) PARTITION (SMALLINT) STATSTIME (TIMESTAMP)
SYSTRIGGERS	DSNOTX01 (UC)	SCHEMA (VARCHAR(128)) NAME (VARCHAR(128)) SEQNO (SMALLINT) VERSION
	DSNOTX02 (N)	TBOWNER (VARCHAR(128)) TBNAME (VARCHAR(128))
	DSNOTX03 (N)	SCHEMA (VARCHAR(128)) TRIGNAME (VARCHAR(128))
SYSTRIGGERS_STMT	DSNOTX04 (A)	STATEMENT (CLOB(2M))
SYSUSERAUTH	DSNAUH01 (N)	GRANTEE (VARCHAR(128)) GRANTEDTS (TIMESTAMP) GRANTEETYPE (CHAR(1))
	DSNAUX02 (N)	GRANTOR (VARCHAR(128)) GRANTORTYPE (CHAR(1))
SYSVARIABLEAUTH	DSNVAX01 (N)	GRANTEE (VARCHAR(128)) GRANTEETYPE (CHAR(1)) SCHEMA (VARCHAR(128)) NAME (VARCHAR(128))
	DSNVAX02 (N)	GRANTOR (VARCHAR(128)) GRANTORTYPE (CHAR(1)) SCHEMA (VARCHAR(128)) NAME (VARCHAR(128))
	DSNVAX03 (N)	SCHEMA (VARCHAR(128)) NAME (VARCHAR(128))
SYSVARIABLES	DSNOVX01 (PU)	SCHEMA (VARCHAR(128)) NAME (VARCHAR(128))

Table 386. Indexes on Db2 catalog tables (continued)

Table	Index (type "1" on page 2767)	Columns (data type)
	DSNOVX04 (N)	TYPESHEMA (VARCHAR(128)) TYPENAME (VARCHAR(128))
SYSVARIABLES_DESC	DSNOVX03 (A)	DESCRIPTOR (CLOB(2M))
SYSVARIABLES_TEXT	DSNOVX02 (A)	DEFAULTTEXT (CLOB(2M))
SYSVIEWDEP	DSNGGX02 (N)	BCREATOR (VARCHAR(128)) BNAME (VARCHAR(128)) BTYPE (CHAR(1))
	DSNGGX03 (N)	BSCHEMA (VARCHAR(128)) BNAME (VARCHAR(128)) BTYPE (CHAR(1))
	DSNGGX04 (N)	BCREATOR (VARCHAR(128)) BNAME (VARCHAR(128)) BTYPE (CHAR(1)) DTYPE (CHAR(1))
	DSNGGX06	DCREATOR (VARCHAR(128)) DNAME (VARCHAR(128)) DTYPE (CHAR(1))
SYSVIEWS	DSNVVX01 (U)	CREATOR (VARCHAR(128)) NAME (VARCHAR(128)) SEQNO (SMALLINT) TYPE (CHAR(1))
SYSVIEWS_STMT	DSNVWX01 (A)	STATEMENT (CLOB(2M))
SYSVIEWS_TREE	DSNVWX02 (A)	PARSETREE (BLOB(1G))
SYSVOLUMES	DSNSSH02 (N)	SGNAME (VARCHAR(128))
SYSXMLRELS	DSNXRX01 (N)	TBOWNER (VARCHAR(128)) TBNAME (VARCHAR(128)) COLNAME (VARCHAR(128))
	DSNXRX02 (N)	XMLTBOWNER (VARCHAR(128)) XMLTBNAME (VARCHAR(128))
SYSXMLSTRINGS	DSNXSX01 (UC)	STRINGID (INTEGER)
	DSNXSX02 (U)	STRING (VARCHAR(1000))

Table 386. Indexes on Db2 catalog tables (continued)

Table	Index (type “1” on page 2767)	Columns (data type)
SYSXMLTYPMOD	DSNTMX01 (PU)	XML_TYPMODE_ID (INTEGER)
SYSXMLTYPMSHEMA	DSNMSX01 (U)	XML_TYPMODE_ID (INTEGER) XSROBJECTID (INTEGER)
	DSNMSX02 (N)	XSROBJECTID (INTEGER)
USERNAMES	DSNFEX01 (U)	TYPE (CHAR(1)) AUTHID (VARCHAR(128)) LINKNAME (CHAR(8))

Notes:

1. The following index types are indicated:

- A**
Auxiliary
 - N**
Nonunique
 - PU**
Primary unique
 - U**
Unique
 - UC**
Unique clustering
 - UD**
Unique descending
-

Related concepts

[Index page set data pages \(Diagnosing Db2 problems\)](#)

Related reference

[Index Page Set Formats \(Diagnosing Db2 problems\)](#)

Appendix I. Db2 directory tables

Db2 for z/OS maintains a set of tables (in database DSNDB01) called the Db2 directory. Authorized users can query the directory; however, it is primarily intended for use by Db2 and is therefore subject to change.

About these topics

These topics describe the directory tables that allow SELECT operations by describing the columns of those tables.

Authorization for SELECT for Db2 directory tables

Users must have one of the following privileges to execute SELECT statements on the directory tables:

- Installation SYSADM
- SYSADM
- SYSCTRL
- ACCESSCTRL
- DATAACCESS
- SECADM
- SQLADM
- System DBADM
- DBADM on DSNDB01
- The SELECT privilege on a specific table

All directory tables are qualified by SYSIBM. Do not use this qualifier for user-defined tables.

The directory tables are not, in most cases, updated as part of Db2 operations.

The following table lists restrictions on SQL statements that reference directory tables:

SQL statement	Restriction
ALTER TABLE	<i>table-name</i> cannot specify a directory table.
ALTER TABLESPACE	The table space cannot be altered if it is associated with a directory table.
CREATE INDEX	ON <i>table-name</i> or <i>aux-table-name</i> cannot specify a directory table.
CREATE TRIGGER (basic)	ON <i>table-name</i> cannot specify a directory table.
CREATE TRIGGER (advanced)	ON <i>table-name</i> cannot specify a directory table.
DELETE	FROM <i>table-name</i> cannot specify a directory table.
DROP	<i>table-name</i> cannot specify a directory table.
INSERT	INTO <i>table-name</i> cannot specify a directory table.
MERGE	INTO <i>table-name</i> cannot specify a directory table.
RENAME	<i>source-table-name</i> cannot specify a directory table.
TRANSFER OWNERSHIP	TABLE <i>table-name</i> cannot specify a directory table.
UPDATE	<i>table-name</i> cannot specify a directory table.

Programming interface information

None of the directory table columns are part of the general-use programming interface. The column labeled "Use" in the table that describes the column indicates whether the column is part of the product-sensitive interface or is for internal, IBM use, only. The values that "Use" can assume are as follows:

Value

Meaning

S

Column is part of the product-sensitive interface

I

Column is for internal use only

For columns for which "Use" is I, the name of the column and its description do not appear in the explanation of the column.

Db2 directory table spaces and indexes

The following table lists the table space and indexes for each directory table and lists the index fields for each index. The indexes are in ascending order.

The directory table space, tables, and indexes are primarily intended for use by Db2 and are therefore subject to change.

Table 387. Table spaces and indexes for the directory tables

TABLE SPACE DSNDB01. ...	TABLE SYSIBM. ...	INDEX SYSIBM. ...	INDEX FIELDS
DBD01	<u>DBDR</u>	DSNDB01X	DBID.SECTION
SYSDBDXA	<u>SYSDBD_DATA</u>	DSNDB1XA	DBD_DATA
SCT02	<u>SCTR</u>	DSNSCT02	SCTNAME.SCTSEC. SPTSEQ
SPT01	<u>SPTR</u>	DSNSPT01	SPTPID.SPTSEC. SPTSEQ
		DSNSPT02	version.SPTID. SPTSEC.SPTSEQ
SYSSPUXA	<u>SYSSPTSEC_DATA</u>	DSNSPDXA	SPTSEC_DATA
SYSSPUXB	<u>SYSSPTSEC_EXPL</u>	DSNSPEXA	SPTSEC_EXPL
SYSLGRNX	<u>SYSLGRNX</u>	DSNLLX01	LGRDBID.LGRPSID. LGRPART.LGRMEMB. LGRSLRSN
		DSNLLX02	LGRDBID.LGRPSID. LGRSLRSN
SYSUTILX	<u>SYSUTIL</u>	DSNLUX01	USUID
	<u>SYSUTILX</u>	DSNLUX02	UTILID.SEQNO

SYSIBM.DBDR table

The DBDR table stores one row for each DBD section. The schema is SYSIBM.

Table 388. SYSIBM.SYSDBDR table column descriptions

Column name	Data type	Description	Use
	INTEGER	Not used	S
DBID	SMALLINT	DBID of the database	S
SECTION	SMALLINT	DBD section number	S
DBD_ROWID	ROWID	ID that is used to support the DBD_DATA column	S
DBD_DATA	BLOB(2G)	DBD data for the section	I

SYSIBM.SYSDBD_DATA table

The SYSDBD_DATA table is an auxiliary table for the SYSIBM.DBDR table. The schema is SYSIBM.

Column name	Data type	Description	Use
DBD_DATA	BLOB(2G)	Contents of the DBD section.	I

SYSIBM.SCTR table

The SCTR table stores Skeleton Cursor Tables (SKCT) information. The schema is SYSIBM.

Table 389. SYSIBM.SCTR table column descriptions

Column name	Data type	Description	Use
SCTLL	CHAR (4) FOR BIT DATA	The length of the record.	S
SCTNAME	CHAR (14) FOR BIT DATA	The plan name, section number, and sequence number.	S
SCTDAT	VARCHAR(4028)	SKCT data.	I

SYSIBM.SPTR table

The SPTR table stores skeleton package table (SKPT) information. The schema is SYSIBM.

Table 390. SYSIBM.SPTR table column descriptions

Column name	Data type	Description	Use
SPTLL	INTEGER	The length of the record.	S
SPTLOCID	VARCHAR(128)	Package location.	S
SPTCOLID	VARCHAR(128)	Package collection ID.	S
SPTNAME	VARCHAR(128)	Package name.	S

Table 390. SYSIBM.SPTR table column descriptions (continued)

Column name	Data type	Description	Use
SPTCONID	CHAR(8) FOR BIT DATA	Package consistency token.	S
SPTRESV	CHAR(2) FOR BIT DATA	Internal use only.	I
SPTSEC	CHAR(4) FOR BIT DATA	Section number.	S
SPTSEQ	CHAR(2) FOR BIT DATA	Sequence number within the section.	S
SPTBODY	VARCHAR(1)	Reserved for future IBM use.	I
SPTVER	VARCHAR(64)	Package version.	S
SPT_ROWID	ROWID	ROWID that Db2 creates for the LOB columns in this table.	S
SPT_DATA	BLOB(2G)	Internal use only.	I
SPT_EXPLAIN	BLOB(2G)	Internal use only.	I

SYSIBM.SYSSPTSEC_DATA table

The SYSSPTSEC_DATA table is an auxiliary table that contains package data for the SPTR table. The schema is SYSIBM.

Table 391. SYSIBM.SYSSPTSEC_DATA table column descriptions

Column name	Data type	Description	Use
SPT_DATA	BLOB(2G)	Contents of the SKPT section	I

SYSIBM.SYSSPTSEC_EXPL table

The SYSSPTSEC_EXPL table is an auxiliary table that contains static package explain data for the SPTR table. The schema is SYSIBM.

Column name	Data type	Description	Use
SPT_EXPLAIN	BLOB(2G)	Contents of the SKPT section explain block	I

SYSIBM.SYSLGRNX table

The SYSLGRNX table stores recovery log ranges that record the time an index space defined with COPY YES or a table space was open for updates. This provides an efficient way for Db2 to access the appropriate log records for recovery, rather than having to scan every record in the recovery log for a particular table. The schema is SYSIBM.

Table 392. SYSIBM.SYSLGRNX table column descriptions

Column name	Data type	Description	Use
LGRDBID	CHAR(2) FOR BIT DATA	DBID of the modified object	S
LGRPSID	CHAR(2) FOR BIT DATA	OBID of the modified object	S
LGRUCDT	CHAR(6)	Modification date in the form <i>mmdyy</i>	S
LGRUCTM	CHAR(8)	Modification time in the form <i>hhmmssst</i>	S
LGRSRBA	CHAR(10) FOR BIT DATA	Starting RBA	S
LGRSPBA	CHAR(10) FOR BIT DATA	Stopping RBA	S
LGRPRT	SMALLINT	Partition number in the table space or index space	S
LGRSLRSN	CHAR(10) FOR BIT DATA	Starting LRSN of update log records for data sharing. Otherwise, the system clock value that corresponds to the first update log record.	S
LGRELRSN	CHAR(10) FOR BIT DATA	Ending LRSN of update log records for data sharing. Otherwise, the system clock value that corresponds to the last update log record.	S
LGRMEMB	CHAR(2)	Data sharing member ID of the modifying Db2 subsystem. X'0000' for a non-data-sharing environment.	S

SYSIBM.SYSUTIL table

The SYSUTIL table stores status information about Db2 utilities that are active or stopped. Each record is uniquely identified by the utility identifier. Each row of the table contains the information for one utility execution step. When the utility completes, the corresponding entries in the SYSUTIL table are deleted. The schema is SYSIBM.

Table 393. SYSIBM.SYSUTIL table column descriptions

Name	Data type	Description	Use
USUUID	CHAR(16)	UTILID value that was passed in a JOB statement parameter	S
USUJOBNM	CHAR(8)	Job name from the JOB statement	S
USUAUID	CHAR(8)	Authorization ID of the invoker	S
USURDATE	CHAR(4) FOR BIT DATA	Date of the utility	S
USUREL	CHAR(3)	Utility release level at restart time	S
USUIRQD	CHAR(1)	IBM required field	S

Table 393. SYSIBM.SYSUTIL table column descriptions (continued)

Name	Data type	Description	Use
USULSIZE	CHAR(4) FOR BIT DATA	List size	S
USULCUR	CHAR(4) FOR BIT DATA	The object that is currently being processed or was last processed	S
USUUTNAM	CHAR(8)	Name of the currently executing utility	S
USUPHASE	CHAR(8)	Current phase of the currently executing utility	S
USUDSNU	CHAR(2) FOR BIT DATA	Data set or piece number	S
USUDSNU2	CHAR(2) FOR BIT DATA	Ending number of the partition range	S
USUSTATU	CHAR(1)	Reserved	I
USUTREQ	CHAR(1)	Termination requested (Y or N)	S
USUFORCE	CHAR(1)	Element of USO forced (Y or N)	S
USURLOK	CHAR(1)	Reload was successful (Y or N)	S
USUCMPOK	CHAR(1)	Compatibility check passed (Y or N)	S
USURSFLG	BIT(8)	Utility restriction flags	S
USURTF LG	BIT(8)	Term settings	S
USURSFLG2	BIT(8)	Utility flags	S
USUPOS	CHAR(4) FOR BIT DATA	Relative USM position in the SYSIN DD statement	S
USUDONE	CHAR(8) FOR BIT DATA	Number of objects processed	S
USUCKSUM	CHAR(4) FOR BIT DATA	USU checksum	S
USUDBOB	CHAR(2) FOR BIT DATA	DBID for the table space	S
USUPSID	CHAR(2) FOR BIT DATA	PSID for the table space or index space	S
USUPSDD	CHAR(2) FOR BIT DATA	Secondary PSID for RECOVER INDEX data page set	S
USUCATMGFRM	CHAR(1) FOR BIT DATA	Saved catalog level for the release from which migration is done, from the DBD01 header page	S

Table 393. SYSIBM.SYSUTIL table column descriptions (continued)

Name	Data type	Description	Use
USUOFLAG	CHAR(1) FOR BIT DATA	Flags for object properties	S
USUDBNAM	CHAR(8)	Database name	S
USUSPNAM	CHAR(8)	Table space or index space name	S
USUMEMBR	CHAR(8)	Member name	S
USUOCATR	CHAR(1) FOR BIT DATA	Saved catalog release level, from the DBD01 header page	S
USUOCATV	CHAR(1) FOR BIT DATA	Saved catalog version level, from the DBD01 header page	S
USUOCATCV	CHAR(1) FOR BIT DATA	Saved migration mode, from the DBD01 header page	S
USUOCATH	CHAR(1) FOR BIT DATA	Saved highest version of the catalog	S
USUUDA	CHAR(150) FOR BIT DATA	Utility-dependent data	S
USURTIME	CHAR(4) FOR BIT DATA	Latest utility start time	S
USURLSN	CHAR(6) FOR BIT DATA	Latest utility start LRSN	S
USURDATO	CHAR(4) FOR BIT DATA	Original utility start date	S
USURTIMO	CHAR(4) FOR BIT DATA	Original utility start time	S
USURLSNO	CHAR(4) FOR BIT DATA	Original utility start LRSN	S
USUR5	CHAR(10) FOR BIT DATA	Reserved	I
USURCNTR	CHAR(31) FOR BIT DATA	Generic counter or value holder	S
USURLSNX	CHAR(10) FOR BIT DATA	Latest utility start LRSN value	S

Table 393. SYSIBM.SYSUTIL table column descriptions (continued)

Name	Data type	Description	Use
USURLSOX	CHAR(10) FOR BIT DATA	Original utility start LRSN value	S
USUR6		Reserved	I
USUWSTRN	CHAR(27000) FOR BIT DATA	Utility-dependent restart information	S

SYSIBM.SYSUTILX table

The SYSUTILX table is a dependent of the SYSUTIL table. A record is created in the SYSUTILX table when the amount of information in the parent record exceeds the record size of SYSUTIL. The rows in SYSUTILX are uniquely identified by the utility identifier and sequence number.

Table 394. SYSIBM.SYSUTILX table column descriptions

Column name	Data type	Description	Use
UTILID	CHAR(16)	The utility ID that identifies the parent record in SYSIBM.SYSUTIL	S
SEQNO	SMALLINT	The sequence number of this row	S
	CHAR(12)	Reserved	I
CHECKPOINT	VARCHAR(32000)	The overflow checkpoint/restart information	S

Related concepts

[Db2 directory \(Introduction to Db2 for z/OS\)](#)

Appendix J. Performance information for SQL application programming

Efficient applications are an important first step to good system and application performance. As you code applications that access data in Db2, consider performance objectives in your application design.

The following topics can help you understand how application programmers can consider performance as they write applications that access data in Db2 for z/OS.

Concurrency and programming

The goal is to program and prepare applications in a way that:

- Protects the integrity of the data that is being read or updated from being changed by other applications.
- Minimizes the length of time that other access to the data is prevented.

For more information about data concurrency in Db2 and recommendations for improving concurrency in your application programs, see the following topics:

- [Programming for concurrency \(Db2 Performance\)](#)
- [Designing databases for concurrency \(Db2 Performance\)](#)
- [Concurrency and locks \(Db2 Performance\)](#)
- [Improving concurrency \(Db2 Performance\)](#)
- [Improving concurrency in data sharing environments \(Db2 Data Sharing Planning and Administration\)](#)

Writing efficient queries

The predicates, subqueries, and other structures in SQL statements affect the access paths that Db2 uses to access the data.

For information about how to write SQL statements that access data efficiently, see the following topics:

- [Ways to improve query performance \(Introduction to Db2 for z/OS\)](#)
- [Writing efficient SQL queries \(Db2 Performance\)](#)

Analyzing access paths

By analyzing the access path that Db2 uses to access the data for an SQL statement, you can discover potential problems. You can use this information to modify your statement to perform better.

Tip: Query tuning capabilities that can help you with this task, such as *visual explain* and *statistics advisor*, are available in [IBM Db2 Administration Foundation for z/OS](#) and [IBM Db2 for z/OS Developer Extension](#).

For information about how you can use EXPLAIN tables to analyze the access paths for your SQL statements, see the following topics:

- [Investigating access path problems \(Db2 Performance\)](#)
- [00C200A4 \(Db2 Codes\)](#)
- [Investigating SQL performance by using EXPLAIN \(Db2 Performance\)](#)
- [Interpreting data access by using EXPLAIN \(Db2 Performance\)](#)
- [EXPLAIN tables \(Db2 Performance\)](#)
- [“EXPLAIN statement” on page 1917](#)

Distributed data access performance

The goal is to reduce the amount of network traffic that is required to access the distributed data, and to manage the use of system resources such as distributed database access threads and connections.

For information about improving the performance of applications that access distributed data, see the following topics:

- [Ways to reduce network traffic \(Introduction to Db2 for z/OS\)](#)
- [Managing Db2 threads \(Db2 Performance\)](#)
- [Improving performance for applications that access distributed data \(Db2 Performance\)](#)
- [Improving performance for SQL statements in distributed applications \(Db2 Performance\)](#)

Stored procedures performance

For information about stored procedures and Db2 performance, see the following topics:

- [Implementing Db2 stored procedures \(Stored procedures provided by Db2\)](#)
- [Improving the performance of stored procedures and user-defined functions \(Db2 Performance\)](#)

Related concepts

[Programming for Db2 for z/OS \(Introduction to Db2 for z/OS\)](#)

Related tasks

[Programming applications for performance \(Db2 Performance\)](#)

[Planning for and designing Db2 applications \(Db2 Application programming and SQL\)](#)

Appendix K. Db2 XML schema repository tables

The Db2 for z/OS XML schema repository (XSR) is a set of Db2 tables where you can store XML schemas.

Db2 creates the XSR tables during installation or migration. After you add XML schemas to the Db2 XSR, you can use them to validate XML documents before you store them in XML columns.

An XML schema consists of a set of XML schema documents. To add an XML schema to the Db2 XSR, you register XML schema documents to Db2. The XML schema documents must be in the Unicode encoding scheme.

Programming interface information

Not all XSR table columns are part of the general-use programming interface. Whether a column is part of this interface is indicated in a column labeled "Use" in the row that describes the table column. The meaning of the values for the "Use" column is indicated in the following table.

Table 395. Meaning of values in the "Use" column if table descriptions

Value	Meaning
G	Column is part of the general-use programming interface
S	Column is part of the product-sensitive interface
I	Column is for IBM use only
N	Column is not used

For columns for which "Use" is N or I, the name of the column and its description do not appear in the explanation of the column.

Related concepts

[XML schema management with the XML schema repository \(XSR\) \(Db2 Programming for XML\)](#)

Related tasks

[Additional steps for enabling the stored procedures and objects for XML schema support \(Db2 Installation and Migration\)](#)

Related information

[Procedures for XML schema registration and removal that are supplied with Db2 \(Db2 Programming for XML\)](#)

XML schema repository (XSR) table spaces and indexes

Db2 XSR tables are contained in certain table spaces and have indexes.

The following tables list the table space and indexes for each XRS table and lists the index fields for each index. The indexes are in ascending order, except where noted.

Table 396. Table spaces and indexes for the DSNXSR database tables

Table space DSNXSR. ...	Table SYSIBM. ...	Index SYSIBM. ...	Index fields
SYSXSR	XSROBJECTS	XSROBJ01	XSROBJECTID
		XSROBJ02	XSROBJECTSCHEMA.XSROBJECTNAME
		XSROBJ03	TARGETNAMESPACE.SCHEMALOCATION

Table 396. Table spaces and indexes for the DSNXSR database tables (continued)

Table space DSNXSR. ...	Table SYSIBM. ...	Index SYSIBM. ...	Index fields
		XSRBJ04	SCHEMALOCATION
	XSROBJECT- COMPONENTS	XSRCOMP01	XSRCOMPONENTID
		XSRCOMP02	TARGETNAMESPACE.SCHEMALOCATION
	XSROBJECT- HIERARCHIES	XSRHIER01	XSROBJECTID.TARGETNAMESPACE. SCHEMALOCATION
		XSRHIER02	XSROBJECTID.TARGETNAMESPACE
SYSXSRA1	XSROBJECTGRAMMAR	XSRXOG01	GRAMMAR
SYSXSRA2	XSROBJECTPROPERTY	XSRXOP01	PROPERTIES
SYSXSRA3	XSRCOMPONENT	XSRXCC01	COMPONENT
SYSXSRA4	XSRPROPERTY	XSRXCP01	PROPERTIES

Note: Index field is in descending order

XSRANNOTATIONINFO table

The XSRANNOTATIONINFO table contains one row for each annotation in an XML schema to record the table and column information for the annotation.

Table 397. SYSIBM.XSRANNOTATIONINFO table column descriptions

Column name	Data type	Description	Use
XSROBJECTID	INTEGER	Internal identifier of the XML schema	G
ANNID	INTEGER	Internal identifier of the XML schema annotation	G
TABSCHEMA	VARCHAR(128)	Schema of the table for which annotation information is recorded	G
TABNAME	VARCHAR(128)	Name of the table for which annotation information is recorded	G
ROWSET	INTEGER	Name of the rowset for this annotation	G
COLNAME	VARCHAR(30)	Name of the column for this annotation	G
COLTYPE	INTEGER	Data type of the column for this annotation	G

Table 397. SYSIBM.XSRANNOTATIONINFO table column descriptions (continued)

Column name	Data type	Description	Use
INSTANCETYPE	INTEGER	Type of data that is provided by the parser during decomposition: 2 Decimal 4 Long integer 5 Integer 6 Short integer 16 String 30 Datetime 41 Float 42 Double	G
TRUNCATE	INTEGER	Indication of whether data can be truncated: 0 Data cannot be truncated 1 Data can be truncated	G
EXPRESSION	VARCHAR(1024)	Expression to be applied to data on insert by Db2	G
CONDITION	VARCHAR(1024)	Condition to be applied before any data is inserted by Db2	G
CASTEXPRESSION	VARCHAR(20)	Cast expression to be applied when the column data is inserted by Db2 during decomposition.	G
RELCREATED	CHAR(1) NOT NULL	The release of Db2 that is used to create the object. See the information on release dependency indicators in Db2 catalog tables for the values.	G

XSRCOMPONENT table

The SYSIBM.XSRCOMPONENT table is an auxiliary table for the BLOB column COMPONENT in the SYSXSROBJECTCOMPONENTS table. It is in LOB table space SYSXSRA3. The schema is SYSIBM.

Table 398. SYSIBM.XSRCOMPONENT table column descriptions

Column name	Data type	Description	Use
COMPONENT	BLOB(30M)	Contents of the XML schema document	G

XSROBJECTS table

The SYSIBM.XSROBJECTS table contains one row for each registered XML schema. The schema is SYSIBM.

Rows in this table can only be changed using static SQL statements issued by the Db2-supplied XSR stored procedures.

Table 399. SYSIBM.XSROBJECTS table column descriptions

Column name	Data type	Description	Use
XSROBJECTID	INTEGER NOT NULL	Internal identifier of the XML schema. XSROBJECTID is generated as an identity column.	G
XSROBJECTSCHEMA	VARCHAR(128) NOT NULL	Qualifier of the XML schema name. This is always set to 'SYSXSR'.	G
XSROBJECTNAME	VARCHAR(128) NOT NULL	Name of the XML schema.	G
TARGETNAMESPACE	INTEGER	The value of the STRINGID column in SYSIBM.SYSXMLSTRINGS when the target namespace URI of the primary XML schema document is stored in SYSIBM.SYSXMLSTRINGS	G
SCHEMALOCATION	INTEGER	The value of the STRINGID column in SYSIBM.SYSXMLSTRINGS when the schema location URI of the primary XML schema document is stored in SYSIBM.SYSXMLSTRINGS	G
ROWID	ROWID NOT NULL GENERATED ALWAYS	The ID that is used to support BLOB data type values.	G
GRAMMAR	BLOB(250M)	The internal binary representation of the XML schema.	G
PROPERTIES	BLOB(5M)	Additional property information of the entire XML schema.	G
CREATEDBY	VARCHAR(128) NOT NULL	Authorization ID under which the XML schema was created.	G
CREATEDTS	TIMESTAMP NOT NULL	The time that the Db2-supplied stored procedure XSR_REGISTER was executed for the XML schema.	G
STATUS	CHAR(1) NOT NULL WITH DEFAULT	Registration status of the XML schema: C Complete I Incomplete T Temporary	G

Table 399. SYSIBM.XSROBJECTS table column descriptions (continued)

Column name	Data type	Description	Use
RELCREATED	CHAR(1) NOT NULL	The release of Db2 that is used to create the object. See Release dependency indicators for the values.	G
	CHAR(1)	Not used.	N
	VARCHAR(128)	Not used.	N
REMARKS	VARCHAR(762)	Character string that contains comments about this XML schema.	G

XSROBJECTCOMPONENTS table

The XSROBJECTCOMPONENTS table contains one row for each component (document) in an XML schema. The schema is SYIBM.

Rows in this table can only be changed using static SQL statements issued by the Db2-supplied XSR stored procedures.

Table 400. SYSIBM.XSROBJECTCOMPONENTS table column descriptions

Column name	Data type	Description	Use
XSRCOMPONENTID	INTEGER NOT NULL	Internal identifier of the XML schema document. XSRCOMPONENTID is generated as an identity column.	G
TARGETNAMESPACE	INTEGER	The value of the STRINGID column in SYSIBM.SYSXMLSTRINGS when the target namespace URI of the primary XML schema document is stored in SYSIBM.SYSXMLSTRINGS.	G
SCHEMALOCATION	INTEGER	The value of the STRINGID column in SYSIBM.SYSXMLSTRINGS when the schema location URI of the primary XML schema document is stored in SYSIBM.SYSXMLSTRINGS.	G
ROWID	ROWID NOT NULL GENERATED ALWAYS	The ID that is used to support BLOB data type values.	G
COMPONENT	BLOB(30M) NOT NULL	Contents of the XML schema document.	G
PROPERTIES	BLOB(5M)	If available, additional property information of the XML schema document	G
CREATEDTS	TIMESTAMP NOT NULL	The time that the XML schema document was registered.	G

Table 400. SYSIBM.XSROBJECTCOMPONENTS table column descriptions (continued)

Column name	Data type	Description	Use
STATUS	CHAR(1) NOT NULL WITH DEFAULT	Registration status of the XML schema: C Complete I Incomplete	G
RELCREATED	CHAR(1) NOT NULL	The release of Db2 that is used to create the object. See Release dependency indicators for the values.	G

XSROBJECTGRAMMAR table

SYSIBM.XSROBJECTGRAMMAR is an auxiliary table for the BLOB column GRAMMAR in SYSIBM.SYSXSROBJECTS. It is in LOB table space SYSXSRA1. The schema is SYSIBM.

Table 401. SYSIBM.XSROBJECTGRAMMAR table column descriptions

Column name	Data type	Description	Use
GRAMMAR	BLOB(250M)	Internal binary representation of the XML schema	G

XSROBJECTHIERARCHIES table

The XSROBJECTHIERARCHIES table contains one row for each component (document) in an XML schema to record the XML schema document hierarchy relationship. The schema is SYSIBM.

Rows in this table can only be changed using static SQL statements issued by the Db2-supplied XSR stored procedures.

Table 402. SYSIBM.XSROBJECTHIERARCHIES table column descriptions

Column name	Data type	Description	Use
XSROBJECTID	INTEGER	Internal identifier of the XML schema.	G
XSRCOMPONENTID	INTEGER	Internal identifier of the XML schema document.	G
HTYPE	CHAR(1)	Hierarchy type: D Document P Primary document	G
TARGETNAMESPACE	INTEGER	The value of the STRINGID column in SYSIBM.SYSXMLSTRINGS when the target namespace URI of the primary XML schema document is stored in SYSIBM.SYSXMLSTRINGS.	G
SCHEMALOCATION	INTEGER	The value of the STRINGID column in SYSIBM.SYSXMLSTRINGS when the schema location URI of the primary XML schema document is stored in SYSIBM.SYSXMLSTRINGS.	G

Table 402. SYSIBM.XSROBJECTHIERARCHIES table column descriptions (continued)

Column name	Data type	Description	Use
RELCREATED	CHAR(1) NOT NULL	The release of Db2 that is used to create the object. See Release dependency indicators for the values.	G

XSROBJECTPROPERTY table

The XSROBJECTPROPERTY table is an auxiliary table for the BLOB column PROPERTIES in SYSIBM.SYSXSROBJECTS. It is in LOB table space SYSXSRA2. The schema is SYSIBM.

Table 403. SYSIBM.XSROBJECTPROPERTY table column descriptions

Column name	Data type	Description	Use
PROPERTIES	BLOB(5M)	Contents of the additional property information of the entire XML schema.	G

XSRPROPERTY table

The XSRPROPERTY table is an auxiliary table for the BLOB column COMPONENT in XSROBJECTCOMPONENTS. It is in LOB table space SYSXSRA3. The schema is SYSIBM.

Table 404. SYSIBM.XSRPROPERTY table column descriptions

Column name	Data type	Description	Use
COMPONENT	BLOB(5M)	Contents of the additional property information of the XML schema document.	G

Appendix L. EXPLAIN tables

EXPLAIN tables contain information about SQL statements and functions that run on Db2 for z/OS.

You can create and maintain a set of *EXPLAIN tables* to capture and analyze information about the performance of SQL statements and functions that run on Db2 for z/OS. Each row in an EXPLAIN table describes some aspect of a step in the execution of a query or subquery in an explainable statement. The column values for the row identify, among other things, the query or subquery, the tables and other objects involved, the methods used to carry out each step, and cost information about those methods. Db2 creates EXPLAIN output and populates EXPLAIN tables in the following situations:

- When an EXPLAIN statement is executed.
- At BIND or REBIND with the EXPLAIN(YES) or (ONLY) bind options. Rows are added for every explainable statement in the plan or package being bound. For a plan, these do not include statements in the packages that can be used with the plan. For either a package or plan, they do not include explainable statements within EXPLAIN statements nor do they include explainable statements that refer to declared temporary tables, which are incrementally bound at run time.
- When an explainable dynamic statement is executed and the value of the CURRENT EXPLAIN MODE special register is set to YES or EXPLAIN.

Important: It is best to convert EXPLAIN tables to Db2 12 format during migration, or soon after migration. In Db2 12, the EXPLAIN function supports tables in Db2 12 or Db2 11 formats only. However, Db2 11 format EXPLAIN tables are deprecated. If you invoke EXPLAIN and Db2 11 tables are used, Db2 issues SQL code +20520. If tables of an unsupported format are found, Db2 issues SQL code -20008 and the EXPLAIN operation fails. You can call the ADMIN_EXPLAIN_MAINT stored procedure to create EXPLAIN tables, upgrade them to the format for the current Db2 release, or complete other maintenance tasks. See “ADMIN_EXPLAIN_MAINT stored procedure” on [page 751](#) for information about using the *action* input parameter to request each of these tasks.

Related concepts

[Interpreting data access by using EXPLAIN \(Db2 Performance\)](#)

[Investigating SQL performance by using EXPLAIN \(Db2 Performance\)](#)

Related tasks

[Capturing access path information in EXPLAIN tables \(Db2 Performance\)](#)

[Migration step 25: Convert EXPLAIN tables to the current format \(Db2 Installation and Migration\)](#)

Related reference

[BIND and REBIND options for packages, plans, and services \(Db2 Commands\)](#)

[EXPLAIN statement](#)

[ADMIN_EXPLAIN_MAINT stored procedure](#)

You can use the ADMIN_EXPLAIN_MAINT stored procedure to create EXPLAIN tables, upgrade the tables to the format for the current Db2 version, and complete other administrative tasks.

PLAN_TABLE

The plan table, PLAN_TABLE, contains information about access paths that is collected from the results of EXPLAIN statements.

Tip: You can generate diagrams of the access paths used for your SQL statements by using the *visual explain* capability in tools such as [IBM Db2 Administration Foundation for z/OS](#) and [IBM Db2 for z/OS Developer Extension](#).

PSPI

Recommendation: Do not manually insert data into system-maintained EXPLAIN tables, and use care when deleting obsolete EXPLAIN table data. The data is intended to be manipulated only by the Db2 EXPLAIN function and optimization tools. Certain optimization tools depend on instances of the various

EXPLAIN tables. Be careful not to delete data from or drop instances EXPLAIN tables that are created for these tools.

Qualifiers

Your subsystem or data sharing group can contain multiple instances of these tables that are qualified by user ID. These tables are populated with statement cost information when you issue the EXPLAIN statement or bind. They are also populated when you specify EXPLAIN(YES) or EXPLAIN(ONLY) in a BIND or REBIND command. SQL optimization tools might also create EXPLAIN tables that are qualified by a user ID. You can find the SQL statement for creating an instance of these tables in member DSNTESC of the SDSNSAMP library.

Sample CREATE TABLE statement

You can find a sample CREATE TABLE statement for each EXPLAIN table in member DSNTESC of the *prefix*.SDSNSAMP library. You can call the ADMIN_EXPLAIN_MAINT stored procedure to create EXPLAIN tables, upgrade them to the format for the current Db2 release, or complete other maintenance tasks. See [“ADMIN_EXPLAIN_MAINT stored procedure” on page 751](#) for information about using the *action* input parameter to request each of these tasks.

Optional PLAN_TABLE formats

A PLAN_TABLE instance can have a format with fewer columns than those shown in the sample CREATE TABLE statement. However instances of PLAN_TABLE must have one of the following formats:

Db2 12 format

All columns shown in the sample CREATE TABLE statement, up to and including the PER_STMT_ID column (COLCOUNT=67).

Db2 11 format

All columns shown in the sample CREATE TABLE statement, up to and including the EXPANSION_REASON column (COLCOUNT=66). This format is deprecated in Db2 12.

Important: If the EXPLAIN tables have any format older than the Db2 11 format, Db2 returns an error for any operation that tries to insert rows in the EXPLAIN tables. You can call the ADMIN_EXPLAIN_MAINT stored procedure to create EXPLAIN tables, upgrade them to the format for the current Db2 release, or complete other maintenance tasks. See [“ADMIN_EXPLAIN_MAINT stored procedure” on page 751](#) for information about using the *action* input parameter to request each of these tasks.

Column descriptions

Your subsystem or data sharing group can contain more than one of these tables, including a table with the qualifier SYSIBM, a table with the qualifier DB2OSCA, and additional tables that are qualified by user IDs.

The following table shows the descriptions of the columns in PLAN_TABLE.

Table 405. Descriptions of columns in PLAN_TABLE

Column name	Data Type	Description
QUERYNO	INTEGER NOT NULL	<p>A number that identifies the statement that is being explained. The origin of the value depends on the context of the row:</p> <p>For rows produced by EXPLAIN statements The number specified in the QUERYNO clause, which is an optional part of the SELECT, INSERT, UPDATE, MERGE, and DELETE statement syntax.</p> <p>For rows not produced by EXPLAIN statements Db2 assigns a number that is based on the line number of the SQL statement in the source program.</p> <p>When the values of QUERYNO are based on the statement number in the source program, values that exceed 32767 are reported as 0. However, in certain rare cases, the value is not guaranteed to be unique.</p> <p>When the SQL statement is embedded in a compiled SQL function, native SQL procedure, or advanced trigger, if the QUERYNO clause is specified, its value is used by Db2. Otherwise Db2 assigns a number based on the line number of the SQL statement in the compiled SQL function, native SQL procedure, or advanced trigger.</p>
QBLOCKNO	SMALLINT NOT NULL	<p>A number that identifies each query block within a query. The value of the numbers are not in any particular order, nor are they necessarily consecutive.</p>
APPLNAME	VARCHAR(24) NOT NULL	<p>The name of the application plan for the row. Applies only to embedded EXPLAIN statements that are executed from a plan or to statements that are explained when binding a plan. A blank indicates that the column is not applicable.</p> <p>When the SQL statement is embedded in a compiled SQL function, native SQL procedure, or advanced trigger, this column is not used, and is blank.</p>

Table 405. Descriptions of columns in PLAN_TABLE (continued)

Column name	Data Type	Description
PROGNAME	VARCHAR(128) NOT NULL	<p>The name of the program or package containing the statement being explained. Applies only to embedded EXPLAIN statements and to statements explained as the result of binding a plan or package. A blank indicates that the column is not applicable.</p> <p>When the SQL statement is embedded in a compiled SQL function or native SQL procedure, this column indicates the specific name of the compiled SQL function or native SQL procedure. When the SQL statement is embedded in an advanced trigger, this column contains the name of the trigger.</p>
PLANNO	SMALLINT NOT NULL	The number of the step in which the query that is indicated in QBLOCKNO was processed. This column indicates the order in which the steps were executed.
METHOD	SMALLINT NOT NULL	<p>A number that indicates the join method that is used for the step:</p> <p>0 The table in this step is the first table that is accessed, a continuation of a previous table that was accessed, or a table that is not used.</p> <p>1 A nested loop join is used. For each row of the current composite table, matching rows of a new table are found and joined.</p> <p>2 A merge scan join is used. The current composite table and the new table are scanned in the order of the join columns, and matching rows are joined.</p> <p>3 Sorts are needed by ORDER BY, GROUP BY, SELECT DISTINCT, UNION, INTERSECT, EXCEPT, a quantified predicate, or an IN predicate. This step does not access a new table.</p> <p>4 A hybrid join was used. The current composite table is scanned in the order of the join-column rows of the new table. The new table is accessed using list prefetch.</p>
CREATOR	VARCHAR(128) NOT NULL	The creator of the new table that is accessed in this step, blank if METHOD is 3.

Table 405. Descriptions of columns in PLAN_TABLE (continued)

Column name	Data Type	Description
TNAME	VARCHAR(128) NOT NULL	<p>The name of one of the following objects:</p> <ul style="list-style-type: none"> • Table • Materialized query table • Created or declared temporary table • Materialized view • Materialized table expression • Any of the following object names that identify intermediate results: <p>'DSNWFQB(qblockno)' The intermediate result of a UNION ALL, INTERSECT ALL, EXCEPT ALL, or an outer join that is materialized. If a view is merged, the name of the view does not appear.</p> <p>'DSN_DIM_TBLX(qblockno)' The work file of a star join dimension table.</p> <p>'DSN_SPIX_TBLX(qblockno)' A sparse index used for a sideways table reference.</p> <p>The value is blank if METHOD is 3.</p>
TABNO	SMALLINT NOT NULL	Values are for IBM use only.
ACCESSTYPE ^{"1" on page 2806}	CHAR(2) NOT NULL	The method of accessing the new table. ^{"4" on page 2806}
MATCHCOLS	SMALLINT NOT NULL	For ACCESSTYPE I, IN, I1, N, NR, MX, or DX, the number of index keys that are used in an index scan; otherwise, 0.
ACCESSCREATOR	VARCHAR(128) NOT NULL	For ACCESSTYPE I, I1, N, NR, MX, or DX, the creator of the index; otherwise, blank.
ACCESSNAME	VARCHAR(128) NOT NULL	For ACCESSTYPE I, I1, H, MH, N, NR, MX, or DX, the name of the index; for ACCESSTYPE P, DSNPJW(<i>mixopseqno</i>) is the starting pair-wise join leg in MIXOPSEQ; otherwise, blank.
INDEXONLY	CHAR(1) NOT NULL	<p>Indication of whether access to an index alone is enough to perform the step, or Indication of whether data too must be accessed.</p> <p>Y Yes</p> <p>N No</p>

Table 405. Descriptions of columns in PLAN_TABLE (continued)

Column name	Data Type	Description
SORTN_UNIQ	CHAR(1) NOT NULL	Indication of whether the new table is sorted to remove duplicate rows. Y Yes N No
SORTN_JOIN	CHAR(1) NOT NULL	Indication of whether the new table is sorted for join method 2 or 4. Y Yes N No
SORTN_ORDERBY	CHAR(1) NOT NULL	Indication of whether the new table is sorted for ORDER BY. Y Yes N No
SORTN_GROUPBY	CHAR(1) NOT NULL	Indication of whether the new table is sorted for GROUP BY. Y Yes N No
SORTC_UNIQ	CHAR(1) NOT NULL	Indication of whether the composite table is sorted to remove duplicate rows. Y Yes N No
SORTC_JOIN	CHAR(1) NOT NULL	Indication of whether the composite table is sorted for join method 1, 2 or 4. Y Yes N No
SORTC_ORDERBY	CHAR(1) NOT NULL	Indication of whether the composite table is sorted for an ORDER BY clause or a quantified predicate. Y Yes N No

Table 405. Descriptions of columns in PLAN_TABLE (continued)

Column name	Data Type	Description
SORTC_GROUPBY	CHAR(1) NOT NULL	<p>Indication of whether the composite table is sorted for a GROUP BY clause.</p> <p>Y Yes</p> <p>N No</p>
TSLOCKMODE	CHAR(3) NOT NULL	<p>An indication of the mode of lock that is acquired on either the new table, or its table space or table space partitions. If the isolation can be determined at bind time, the values are:</p> <p>IS Intent share lock</p> <p>IX Intent exclusive lock</p> <p>S Share lock</p> <p>U Update lock</p> <p>X Exclusive lock</p> <p>SIX Share with intent exclusive lock</p> <p>N UR isolation; no lock</p> <p>If the isolation level cannot be determined at bind time, the lock mode is determined by the isolation level at run time is shown by the following values.</p> <p>NS For UR isolation, no lock; for CS, RS, or RR, an S lock.</p> <p>NIS For UR isolation, no lock; for CS, RS, or RR, an IS lock.</p> <p>NSS For UR isolation, no lock; for CS or RS, an IS lock; for RR, an S lock.</p> <p>SS For UR, CS, or RS isolation, an IS lock; for RR, an S lock.</p> <p>Continues in next row.</p>

Table 405. Descriptions of columns in PLAN_TABLE (continued)

Column name	Data Type	Description
TSLOCKMODE (continued)		Continued from previous row. The data in this column is right justified. For example, IX appears as a blank, followed by I, followed by X. If the column contains a blank, then no lock is acquired. If the access method in the ACESSTYPE column is DX, DI, or DU, no latches are acquired on the XML index page and no lock is acquired on the new base table data page or row, nor on the XML table and the corresponding table spaces. The value of TSLOCKMODE is a blank in this case.
TIMESTAMP	CHAR(16) NOT NULL	This column is deprecated. Use EXPLAIN_TIME instead.
REMARKS	VARCHAR(762) NOT NULL	A field into which you can insert any character string of 762 or fewer characters. Db2 inserts a value into this column in certain situations. “6” on page 2808 , “7” on page 2809
PREFETCH	CHAR(1) NOT NULL WITH DEFAULT	Indication of whether data pages are to be read in advance by prefetch: 'D' Optimizer expects dynamic prefetch 'S' Pure sequential prefetch 'L' Prefetch through a page list 'U' List prefetch with an unsorted RID list blank Unknown or no prefetch

Table 405. Descriptions of columns in PLAN_TABLE (continued)

Column name	Data Type	Description
COLUMN_FN_EVAL	CHAR(1) NOT NULL WITH DEFAULT	<p>When an SQL aggregate function is evaluated:</p> <p>'R' While the data is being read from the table or index</p> <p>'S' While performing a sort to satisfy a GROUP BY clause</p> <p>'X' While data is read from a table or index, for aggregate functions when an OFFSET clause is specified</p> <p>'Y' While performing a sort, for aggregate functions when an OFFSET clause is specified</p> <p>blank After data retrieval and after any sorts</p>
MIXOPSEQ	SMALLINT NOT NULL WITH DEFAULT	<p>The sequence number of a step in a multiple index operation.</p> <p>1, 2, ... n For the steps of the multiple index procedure (ACCESSTYPE is MX, MI, MU, DX, DI, or DU), the sequence number of the OR predicate in the SQL statement. (ACCESSTYPE is 'NR').</p> <p>0 For any other rows.</p>

Table 405. Descriptions of columns in PLAN_TABLE (continued)

Column name	Data Type	Description
VERSION	VARCHAR(122) NOT NULL WITH DEFAULT	<p>The version identifier for the package. Applies only to an embedded EXPLAIN statement executed from a package, to a statement that is explained when binding a package, or to a manually created PLAN_TABLE row for an optimization hint.</p> <p>If the value is not blank, the value is the same as one of the following:</p> <ul style="list-style-type: none"> • The VERSION value for the package that was used to create this EXPLAIN table row. • For a manually created EXPLAIN table row, the VERSION value that identifies the statement for which the hint is used. <p>For a row that is created by execution of an EXPLAIN statement or by binding a package with the EXPLAIN option, the version is blank for a statement in:</p> <ul style="list-style-type: none"> • A package for a basic trigger (TYPE='T') • A package for an application that was precompiled without SQL processing option VERSION • A package that was precompiled with an empty string for the VERSION value (TYPE=blank) <p>When the SQL statement is embedded in a compiled SQL function or native SQL procedure, this column indicates the version identifier of the function or procedure. When the SQL statement is embedded in an advanced trigger body, this column is not used and will be blank.</p>
COLLID	VARCHAR(128) NOT NULL WITH DEFAULT	<p>The collection ID:</p> <p>'DSNDYNAMICSQLCACHE' The row originates from the dynamic statement cache.</p> <p>'DSNEXPLAINMODEYES' The row originates from an application that specifies YES for the value of the CURRENT EXPLAIN MODE special register.</p> <p>'DSNEXPLAINMODEEXPLAIN' The row originates from an application that specifies EXPLAIN for the value of the CURRENT EXPLAIN MODE special register.</p> <p>When the SQL statement is embedded in a compiled SQL function, native SQL procedure, or advanced trigger, this column indicates the schema name of the compiled SQL function, native SQL procedure, or advanced trigger.</p>

Table 405. Descriptions of columns in PLAN_TABLE (continued)

Column name	Data Type	Description
ACCESS_DEGREE	SMALLINT	The number of parallel tasks or operations that are activated by a query. This value is determined at bind time; the actual number of parallel operations that are used at execution time could be different. This column contains 0 if a host variable is used. This column contains the null value if the plan or package was bound using a plan table with fewer than 43 columns. Otherwise, it can contain null if the method that it refers to does not apply.
ACCESS_PGROUP_ID ^{"2"} on page 2806	SMALLINT	The identifier of the parallel group for accessing the new table. A parallel group is a set of consecutive operations, executed in parallel, that have the same number of parallel tasks. This value is determined at bind time; it could change at execution time. This column contains the null value if the plan or package was bound using a plan table with fewer than 43 columns. Otherwise, it can contain null if the method that it refers to does not apply.
JOIN_DEGREE	SMALLINT	The number of parallel operations or tasks that are used in joining the composite table with the new table. This value is determined at bind time and can be 0 if a host variable is used. The actual number of parallel operations or tasks used at execution time could be different. This column contains the null value if the plan or package was bound using a plan table with fewer than 43 columns. Otherwise, it can contain null if the method that it refers to does not apply.
JOIN_PGROUP_ID ^{"2"} on page 2806	SMALLINT	The identifier of the parallel group for joining the composite table with the new table. This value is determined at bind time; it could change at execution time. This column contains the null value if the plan or package was bound using a plan table with fewer than 43 columns. Otherwise, it can contain null if the method that it refers to does not apply.
SORTC_PGROUP_ID ^{"3"} on page 2806	SMALLINT	The parallel group identifier for the parallel sort of the composite table. This column contains the null value if the plan or package was bound using a plan table with fewer than 43 columns. Otherwise, it can contain null if the method that it refers to does not apply.
SORTN_PGROUP_ID ^{"3"} on page 2806	SMALLINT	The parallel group identifier for the parallel sort of the new table. This column contains the null value if the plan or package was bound using a plan table with fewer than 43 columns. Otherwise, it can contain null if the method that it refers to does not apply.

Table 405. Descriptions of columns in PLAN_TABLE (continued)

Column name	Data Type	Description
PARALLELISM_ MODE“2” on page 2806	CHAR(1)	The kind of parallelism, if any, that is used at bind time: C Query CP parallelism. This column contains the null value if the plan or package was bound using a plan table with fewer than 43 columns, if the method that it refers to does not apply, or if the plan or package was bound prior to DB2 10.
MERGE_ JOIN_ COLS	SMALLINT	The number of columns that are joined during a merge scan join (Method=2). This column contains the null value if the plan or package was bound using a plan table with fewer than 43 columns. Otherwise, it can contain null if the method that it refers to does not apply.
CORRELATION_ NAME	VARCHAR(128)	The correlation name of a table or view that is specified in the statement. If no correlation name exists, then the column is null. This column contains the null value if the plan or package was bound using a plan table with fewer than 43 columns. Otherwise, it can contain null if the method that it refers to does not apply.
PAGE_RANGE	CHAR(1) NOT NULL WITH DEFAULT	Indication of whether the table qualifies for page range screening, so that plans scan only the partitions that are needed. Y Yes blank No
JOIN_TYPE	CHAR(1) NOT NULL WITH DEFAULT	The type of join: F FULL OUTER JOIN L LEFT OUTER JOIN P Pair-wise join S Star join blank INNER JOIN or no join RIGHT OUTER JOIN converts to a LEFT OUTER JOIN when you use it, so that JOIN_TYPE contains L.

Table 405. Descriptions of columns in PLAN_TABLE (continued)

Column name	Data Type	Description
GROUP_MEMBER	VARCHAR(24) NOT NULL WITH DEFAULT	The member name of the Db2 that executed EXPLAIN. The column is blank if the Db2 subsystem was not in a data sharing environment when EXPLAIN was executed.
IBM_SERVICE_DATA	VARCHAR(254) FOR BIT DATA	This column contains values that are for IBM use only.
WHEN_OPTIMIZE	CHAR(1) NOT NULL WITH DEFAULT	When the access path was determined: blank At bind time, using a default filter factor for any host variables, parameter markers, or special registers. B At bind time, using a default filter factor for any host variables, parameter markers, or special registers; however, the statement is re-optimized at run time using input variable values for input host variables, parameter markers, or special registers. The bind option REOPT(ALWAYS), REOPT(AUTO), or REOPT(ONCE) must be specified for reoptimization to occur. R At run time, using input variables for any host variables, parameter markers, or special registers. The bind option REOPT(ALWAYS), REOPT(AUTO), or REOPT(ONCE) must be specified for this to occur.
QBLOCK_TYPE ^{“1” on page 2806}	CHAR(6) NOT NULL WITH DEFAULT	For each query block, an indication of the type of SQL operation that is performed. For the outermost query, this column identifies the statement type. ^{“5” on page 2807}
BIND_TIME	TIMESTAMP NOT NULL WITH DEFAULT	This column is deprecated. Use EXPLAIN_TIME instead.
OPTHINT	VARCHAR(128) NOT NULL WITH DEFAULT	A string that you use to identify this row as an optimization hint for Db2. Db2 uses this row as input when choosing an access path.

Table 405. Descriptions of columns in PLAN_TABLE (continued)

Column name	Data Type	Description
HINT_USED	VARCHAR(128) NOT NULL WITH DEFAULT	<p>One of the following values:</p> <p>'APREUSE' When an access path was successfully reused because the APREUSE option was specified at bind or rebind.</p> <p>'opthint-value' When PLAN_TABLE access path hints are used. <i>opthint-value</i> is the value of the OPTHINT column for the hint that was used.</p> <p>'SYSQUERYPLAN query-id' When statement-level access path hints are used. <i>query-id</i> is the value of the QUERYID column in the SYSQUERYPLAN catalog table for the hint.</p> <p>'SYSQUERYSEL query-id' When a predicate selectivity override is used. <i>query-id</i> is the value of the QUERYID column of the SYSQUERYSEL catalog table row for the hint.</p> <p>'EXPLAIN PACKAGE: COPY copy-id' When the row is the result of an EXPLAIN PACKAGE statement. <i>copy-id</i> is one of the following values:</p> <p>CURRENT The current copy of the package.</p> <p>PREVIOUS The previous copy of the package.</p> <p>ORIGINAL The original copy of the package.</p> <p>'EXPLAIN SDQ: copy-id-number' The string <i>copy-id-number</i> can have one of the following values:</p> <p>CURRENT The current copy.</p> <p>INVALID The invalid copy.</p>

Table 405. Descriptions of columns in PLAN_TABLE (continued)

Column name	Data Type	Description
PRIMARY_ ACCESSTYPE	CHAR(1) NOT NULL WITH DEFAULT	<p>Indicates whether direct row access is attempted first:</p> <p>'D' Db2 tries to use direct row access with a rowid column. If Db2 cannot use direct row access with a rowid column at run time, it uses the access path that is described in the ACCESSTYPE column of PLAN_TABLE.</p> <p>'P' Db2 used data partitioned secondary index and a part-level operation to access the data.</p> <p>'S' Db2 used sparse index access for a sideways table reference.</p> <p>'T' The base table or result file is materialized into a work file, and the work file is accessed via sparse index access. If a base table is involved, then ACCESSTYPE indicates how the base table is accessed.</p> <p>blank Db2 does not try to use direct row access by using a rowid column or sparse index access for a work file. The value of the ACCESSTYPE column of PLAN_TABLE provides information on the method of accessing the table.</p>
PARENT_QBLOCKNO	SMALLINT NOT NULL WITH DEFAULT	A number that indicates the QBLOCKNO of the parent query block.

Table 405. Descriptions of columns in PLAN_TABLE (continued)

Column name	Data Type	Description
TABLE_TYPE	CHAR(1)	<p>The type of new table:</p> <p>'B' Buffers for SELECT from INSERT, SELECT from UPDATE, SELECT from MERGE, or SELECT from DELETE statement.</p> <p>'C' Common table expression</p> <p>'F' Table function</p> <p>'I' The new table is generated from an IN-LIST predicate. If the IN-LIST predicate is selected as the matching predicate, it will be accessed as an in-memory table.</p> <p>'M' Materialized query table</p> <p>'Q' Temporary intermediate result table (not materialized). For the name of a view or nested table expression, a value of Q indicates that the materialization was virtual and not actual. Materialization can be virtual when the view or nested table expression definition contains a UNION ALL that is not distributed.</p> <p>'R' Recursive common table expression</p> <p>'S' Subquery (correlated or non-correlated)</p> <p>'T' Table</p> <p>'W' Work file</p> <p>The value of the column is null if the query uses GROUP BY, ORDER BY, or DISTINCT, which requires an implicit sort.</p>
TABLE_ENCODE	CHAR(1) NOT NULL WITH DEFAULT	<p>The encoding scheme of the table. The possible values are:</p> <p>'A' ASCII</p> <p>'E' EBCDIC</p> <p>'U' Unicode</p> <p>'M' The table contains multiple CCSID sets</p>

Table 405. Descriptions of columns in PLAN_TABLE (continued)

Column name	Data Type	Description
TABLE_SCCSID	SMALLINT NOT NULL WITH DEFAULT	The SBCS CCSID value of the table. If column TABLE_ENCODE is M, the value is 0.
TABLE_MCCSID	SMALLINT NOT NULL WITH DEFAULT	The mixed CCSID value of the table. If the value of the TABLE_ENCODE column is M, the value is 0. If MIXED=NO in the application defaults module, the value is -2.
TABLE_DCCSID	SMALLINT NOT NULL WITH DEFAULT	The DBCS CCSID value of the table. If the value of the TABLE_ENCODE column is M, the value is 0. If MIXED=NO in the application defaults module, the value is -2.
ROUTINE_ID	INTEGER NOT NULL WITH DEFAULT	The values in this column are for IBM use only.
CTEREF	SMALLINT NOT NULL WITH DEFAULT	If the referenced table is a common table expression, the value is the top-level query block number.
STMTTOKEN	VARCHAR(240)	User-specified statement token.
PARENT_PLANNO	SMALLINT NOT NULL	Corresponds to the plan number in the parent query block where a correlated subquery is invoked. Or, for non-correlated subqueries, corresponds to the plan number in the parent query block that represents the work file for the subquery.
BIND_EXPLAIN_ONLY	CHAR(1) NOT NULL WITH DEFAULT	Identifies whether the row was inserted because a command specified the EXPLAIN(ONLY) option.
SECTNOI	INTEGER NOT NULL WITH DEFAULT	The section number of the statement. The value is taken from the same column in SYSPACKSTMT or SYSSTMT tables and can be used to join tables to reconstruct the access path for the statement. This column is applicable only for static statements. The default value of -1 indicates EXPLAIN information that was captured in DB2 9 or earlier.

Table 405. Descriptions of columns in PLAN_TABLE (continued)

Column name	Data Type	Description
EXPLAIN_TIME	TIMESTAMP NOT NULL WITH DEFAULT	<p>The time when the EXPLAIN information was captured:</p> <p>All cached statements When the statement entered the cache, in the form of a full-precision timestamp value.</p> <p>Non-cached static statements When the statement was bound, in the form of a full precision timestamp value.</p> <p>Non-cached dynamic statements When EXPLAIN was executed, in the form of a value equivalent to a CHAR(16) representation of the time appended by 4 zeros.</p>
MERGC	CHAR(1) NOT NULL WITH DEFAULT	<p>Indicates whether the composite table is consolidated before the join.</p> <p>'Y' Yes</p> <p>'N' No</p>
MERGN	CHAR(1) NOT NULL WITH DEFAULT	<p>Indicates whether the new table is consolidated before the join, or whether access that used a data partitioned secondary index (DPSI) involved a merge operation.</p> <p>'Y' Yes, the new table is consolidated before the join.</p> <p>'N' No, the new table is not consolidated before the join</p> <p>'D' Access through a DPSI involved a merge operation.</p> <p>'U' Access through a DPSI that did not involve a merge operation.</p>
SCAN_DIRECTION	CHAR(1)	<p>For index access, the direction of the index scan:</p> <p>'F' Forward</p> <p>'R' Reverse</p> <p>blank Index scan is not used</p>

Table 405. Descriptions of columns in PLAN_TABLE (continued)

Column name	Data Type	Description
EXPANSION_REASON	CHAR(2) NOT NULL WITH DEFAULT	<p>This column applies only to statements that reference archive tables or temporal tables. For other statements, this column is blank.</p> <p>Indicates the effect of the CURRENT TEMPORAL BUSINESS_TIME special register, the CURRENT TEMPORAL SYSTEM_TIME special register, and the SYSIBMADM.GET_ARCHIVE built-in global variable. These items are controlled by the BUSTIMESENSITIVE, SYSTIMESENSITIVE, and ARCHIVESENSITIVE bind options.</p> <p>Db2 implicitly adds certain syntax to the query if one of the following conditions are true:</p> <ul style="list-style-type: none"> • The SYSIBMADM.GET_ARCHIVE global variable is set to Y and the ARCHIVESENSITIVE bind option is set to YES • The CURRENT TEMPORAL BUSINESS_TIME special register is not null and the BUSTIMESENSITIVE bind option is set to YES • The CURRENT TEMPORAL SYSTEM_TIME special register is not null and the SYSTIMESENSITIVE bind option is set to YES
EXPANSION_REASON (continued)		<p>This column can have one of the following values:</p> <p>'A' The query contains implicit query transformation as a result of the SYSIBMADM.GET_ARCHIVE built-in global variable.</p> <p>'B' The query contains implicit query transformation as a result of the CURRENT TEMPORAL BUSINESS_TIME special register.</p> <p>'S' The query contains implicit query transformation as a result of the CURRENT TEMPORAL SYSTEM_TIME special register.</p> <p>'SB' The query contains implicit query transformation as a result of the CURRENT TEMPORAL SYSTEM_TIME special register and the CURRENT TEMPORAL BUSINESS_TIME special register.</p> <p>blank The query does not contain implicit query transformation.</p>

Table 405. Descriptions of columns in PLAN_TABLE (continued)

Column name	Data Type	Description
PER_STMT_ID	BIGINT NOT NULL	<p>The persistent statement identifier for SQL statements in Db2 catalog tables.</p> <p>For example, this column corresponds to the following catalog table columns that identify SQL statements:</p> <ul style="list-style-type: none"> • STMT_ID in SYSIBM.SYSPACKSTMT, for SQL statements in packages. • SDQ_STMT_ID in SYSIBM.SYSDYNQUERY, for stabilized dynamic SQL statements.
AP_PLANID	CHAR(16) FOR BIT DATA	A unique identifier for BIND or PREPARE optimizations for an SQL statement, in the form of an extended timestamp value.

Notes:

1. For PLAN_TABLE rows in which ACESSTYPE='A' and QBLOCK_TYPE='SELECT', the values of all other columns except QUERYNO, APPLNAME, and PROGRAM are the default values for those columns.
2. In rows that are used for optimization hints, NULL values in the following columns indicate a hint for no parallelism:
 - PARALLELISM_MODE
 - ACCESS_PGROUP_ID
 - JOIN_PGROUP_ID
3. In rows that are used for optimization hints, NULL values in the following columns indicate a hint for no parallel sort:
 - SORTN_PGROUP_ID
 - SORTC_PGROUP_ID
4. The ACESSTYPE column contains the following values:
 - 'A'
The query is sent to an accelerator server.
 - 'DI'
By an intersection of multiple DOCID lists to return the final DOCID list
 - 'DU'
By a union of multiple DOCID lists to return the final DOCID list
 - 'DX'
By an XML index scan on the index that is named in ACCESSNAME to return a DOCID list
 - 'E'
By direct row access using a row change timestamp column.
 - 'H'
By hash access. IF an overflow condition occurs, the hash overflow index that is identified by ACCESSCREATOR and ACCESSNAME is used.
 - 'HN'
By hash access using an IN predicate, or an IN predicate that Db2 generates. If a hash overflow condition occurs, the hash overflow index that is identified in ACCESSCREATOR and ACCESSNAME is used.
 - 'I'
By an index (identified in ACCESSCREATOR and ACCESSNAME)

'IN'

By an index scan when the matching predicate contains an IN predicate and the IN-list is accessed through an in-memory table.

'I1'

By a one-fetch index scan

'M'

By a multiple index scan. A row that contains this value might be followed by a row that contains one of the following values:

- 'DI'
- 'DU'
- 'MH'
- 'MI'
- 'MU'
- 'MX'

'MH'

By the hash overflow index named in ACCESSNAME. A row that contains this value always follows a row that contains M.

'MI'

By an intersection of multiple indexes. A row that contains this value always follows a row that contains M.

'MU'

By a union of multiple indexes. A row that contains this value always follows a row that contains M.

'MX'

By an index scan on the index named in ACCESSNAME. When the access method MX follows the access method DX, DI, or DU, the table is accessed by the DOCID index by using the DOCID list that is returned by DX, DI, or DU. A row that contains this value always follows a row that contains M.

'N'

One of the following types:

- By an index scan when the matching predicate contains the IN keyword
- By an index scan when Db2 rewrites a query using the IN keyword

'O'

Use of a work file was avoided when processing the result of a subquery, table expression, view, or intermediate result table.

'NR'

Range list access.

'P'

By a dynamic pair-wise index scan

'R'

By a table space scan

'RW'

By a work file scan of the result of a materialized user-defined table function

'V'

By buffers for an INSERT statement within a SELECT

blank

Not applicable to the current row

5. The QBLOCK_TYPE column contains the following values:

'SELECT'

SELECT

'INSERT'

INSERT

'UPDATE'

UPDATE

'MERGE'

MERGE

'DELETE'

DELETE

'SELUPD'

SELECT with FOR UPDATE OF

'DELCUR'

DELETE WHERE CURRENT OF CURSOR

'UPDCUR'

UPDATE WHERE CURRENT OF CURSOR

'CORSUB'

Correlated subselect or fullselect

'COTBLX'

A table expression with a sideways reference.

'TRUNCA'

TRUNCATE

'NCOSUB'

Noncorrelated subselect or fullselect

'TABLEX'

Table expression

'TRIGGR'

WHEN clause on CREATE TRIGGER

'UNION'

UNION

'UNIONA'

UNION ALL

'INTERS'

INTERSECT

'INTERA'

INTERSECT ALL

'EXCEPT'

EXCEPT

'EXCPTA'

EXCEPT ALL

'PRUNED'

Db2 does not generate an access path for the query because the query is guaranteed to qualify zero rows, such as the case of an always-false WHERE clause. For example: WHERE 0=1

6. Db2 inserts a value into the REMARKS column at bind or rebind when the EXPLAIN(ONLY) option is specified and reuse or comparison fails for an access path. The value might include the following information:

- A reason code that corresponds to the reason codes in [SQLCODE +395](#) when reuse fails
- The name of the unmatched PLAN_TABLE column for which comparison failed
- The string 'UNMATCHED ROW(S)', which indicates that there are extra rows in addition to the rows in the original access path, or there are fewer rows than in the original access path.

The values that are in the REMARKS column as a result of a reuse or comparison failure do not describe all the access path differences. The REMARKS values are not sufficient to determine if an access path change is acceptable. They are an indication that further analysis might be necessary to determine how the access path has changed, and whether the changes warrant any further action.

7. Db2 inserts a value into the REMARKS column when selectivity overrides cannot be used for a statement. The value contains a reason code that indicates why the selectivity override was not used. The value might also contain additional diagnostic information.

The reason code values correspond to [SQLCODE +395](#) reason codes:

'1'-'41'

Indicate that an optimization hint that was generated as part of the extended optimization process cannot be applied. Use only a single selectivity instance.

'42'

Indicates that the structure of the selectivity override is not valid. Generate the selectivity override again.

'43'

The selectivity override cannot be applied because of an unexpected error. If the problem persists, you might need to contact IBM Support.

'44'-'99'

Indicate that an optimization hint that was generated as part of the extended optimization process cannot be applied. Use only a single selectivity instance.

The PLAN_TABLE_HINT_IX index

The PLAN_TABLE_HINT_IX index improves prepare performance when access path hints are used. This index is required for statement-level access paths and optimization parameters. The PLAN_TABLE_HINT_IX index is optional, although strongly recommended, for PLAN_TABLE access path hints.

The statement that creates the PLAN_TABLE_HINT_IX index is included as part of the DSNTEESC member of the SDSNSAMP library. 

Related concepts

[Interpreting data access by using EXPLAIN \(Db2 Performance\)](#)

Related tasks

[Preparing to influence access paths \(Db2 Performance\)](#)

Related reference

[EXPLAIN statement](#)

Related information

[IBM Db2 Analytics Accelerator for z/OS documentation](#)

DSN_COLDIST_TABLE

The column distribution table contains non-uniform column group statistics that are obtained dynamically by Db2 from non-index leaf pages.



Recommendation: Do not manually insert data into system-maintained EXPLAIN tables, and use care when deleting obsolete EXPLAIN table data. The data is intended to be manipulated only by the Db2 EXPLAIN function and optimization tools. Certain optimization tools depend on instances of the various EXPLAIN tables. Be careful not to delete data from or drop instances EXPLAIN tables that are created for these tools.

Qualifiers

Your subsystem or data sharing group can contain multiple instances of these tables that are qualified by user ID. These tables are populated with statement cost information when you issue the EXPLAIN statement or bind. They are also populated when you specify EXPLAIN(YES) or EXPLAIN(ONLY) in a BIND or REBIND command. SQL optimization tools might also create EXPLAIN tables that are qualified by a user ID. You can find the SQL statement for creating an instance of these tables in member DSNTESC of the SDSNSAMP library.

Sample CREATE TABLE statement

You can find a sample CREATE TABLE statement for each EXPLAIN table in member DSNTESC of the *prefix*.SDSNSAMP library. You can call the ADMIN_EXPLAIN_MAINT stored procedure to create EXPLAIN tables, upgrade them to the format for the current Db2 release, or complete other maintenance tasks. See “ADMIN_EXPLAIN_MAINT stored procedure” on page 751 for information about using the *action* input parameter to request each of these tasks.

Column descriptions

PSPI

The following table shows the descriptions of the columns in the DSN_COLDIST_TABLE table.

Table 406. Descriptions of columns in DSN_COLDIST_TABLE

Column name	Data Type	Description
QUERYNO	INTEGER NOT NULL	<p>A number that identifies the statement that is being explained. The origin of the value depends on the context of the row:</p> <p>For rows produced by EXPLAIN statements The number specified in the QUERYNO clause, which is an optional part of the SELECT, INSERT, UPDATE, MERGE, and DELETE statement syntax.</p> <p>For rows not produced by EXPLAIN statements Db2 assigns a number that is based on the line number of the SQL statement in the source program.</p> <p>When the values of QUERYNO are based on the statement number in the source program, values that exceed 32767 are reported as 0. However, in certain rare cases, the value is not guaranteed to be unique.</p> <p>When the SQL statement is embedded in a compiled SQL function, native SQL procedure, or advanced trigger, if the QUERYNO clause is specified, its value is used by Db2. Otherwise Db2 assigns a number based on the line number of the SQL statement in the compiled SQL function, native SQL procedure, or advanced trigger.</p>

Table 406. Descriptions of columns in DSN_COLDIST_TABLE (continued)

Column name	Data Type	Description
APPLNAME	VARCHAR(128) NOT NULL	<p>The name of the application plan for the row. Applies only to embedded EXPLAIN statements that are executed from a plan or to statements that are explained when binding a plan. A blank indicates that the column is not applicable.</p> <p>When the SQL statement is embedded in a compiled SQL function, native SQL procedure, or advanced trigger, this column is not used, and is blank.</p>
PROGNAME	VARCHAR(128) NOT NULL	<p>The name of the program or package containing the statement being explained. Applies only to embedded EXPLAIN statements and to statements explained as the result of binding a plan or package. A blank indicates that the column is not applicable.</p> <p>When the SQL statement is embedded in a compiled SQL function or native SQL procedure, this column indicates the specific name of the compiled SQL function or native SQL procedure. When the SQL statement is embedded in an advanced trigger, this column contains the name of the trigger.</p>
COLLID	VARCHAR(128) NOT NULL	<p>The collection ID:</p> <p>'DSNEXPLAINMODEYES' The row originates from an application that specifies YES for the value of the CURRENT EXPLAIN MODE special register.</p> <p>'DSNEXPLAINMODEEXPLAIN' The row originates from an application that specifies EXPLAIN for the value of the CURRENT EXPLAIN MODE special register.</p> <p>When the SQL statement is embedded in a compiled SQL function, native SQL procedure, or advanced trigger, this column indicates the schema name of the compiled SQL function, native SQL procedure, or advanced trigger.</p>
GROUP_MEMBER	VARCHAR(128) NOT NULL	<p>The member name of the Db2 that executed EXPLAIN. The column is blank if the Db2 subsystem was not in a data sharing environment when EXPLAIN was executed.</p>

Table 406. Descriptions of columns in DSN_COLDIST_TABLE (continued)

Column name	Data Type	Description
SECTNOI	INTEGER NOT NULL	The section number of the statement. The value is taken from the same column in SYSPACKSTMT or SYSSTMT tables and can be used to join tables to reconstruct the access path for the statement. This column is applicable only for static statements. The default value of -1 indicates EXPLAIN information that was captured in DB2 9 or earlier.
VERSION	VARCHAR(122) NOT NULL	<p>The version identifier for the package. Applies only to an embedded EXPLAIN statement executed from a package or to a statement that is explained when binding a package.</p> <p>If the value is not blank, the value is the same as the VERSION value for the package that was used to create this EXPLAIN table row.</p> <p>The value is blank for a statement in:</p> <ul style="list-style-type: none"> • A package for a basic trigger (TYPE='T') • A package for an application that was precompiled without SQL processing option VERSION • A package that was precompiled with an empty string for the VERSION value (TYPE=blank) <p>When the SQL statement is embedded in a compiled SQL function or native SQL procedure, this column indicates the version identifier of the function or procedure. When the SQL statement is embedded in an advanced trigger body, this column is not used and will be blank.</p>
EXPLAIN_TIME	TIMESTAMP NOT NULL	<p>The time when the EXPLAIN information was captured:</p> <p>All cached statements When the statement entered the cache, in the form of a full-precision timestamp value.</p> <p>Non-cached static statements When the statement was bound, in the form of a full precision timestamp value.</p> <p>Non-cached dynamic statements When EXPLAIN was executed, in the form of a value equivalent to a CHAR(16) representation of the time appended by 4 zeros.</p>
SCHEMA	VARCHAR(128) NOT NULL	The schema of the table that contains the column.

Table 406. Descriptions of columns in DSN_COLDIST_TABLE (continued)

Column name	Data Type	Description
TBNAME	VARCHAR(128) NOT NULL	The name of the table that contains the column.
NAME	VARCHAR(128) NOT NULL	Name of the column. If the value of NUMCOLUMNS is greater than 1, this name identifies the first column name of the set of columns associated with the statistics.
COLVALUE	VARCHAR(2000) NOT NULL FOR BIT DATA	<p>Contains the data of a frequently occurring value in the column. Statistics are not collected for an index on a ROWID column. If the value has a non-character data type, the data might not be printable.</p> <p>This column might contain values that depend on the value of the type column:</p> <p>TYPE='T' One of the following values:</p> <ul style="list-style-type: none"> • 'E3C2C1C3C1D9C4C6' for TBACARDF • 'E3C2C1D5C1C3E3C6' for TBANPAGF • 'E3C2C1D5D7C1C7C6' for TBANACTF <p>TYPE='L' 'C3C1E3C6D3C4C3C6' for CATFLDCF</p> <p>TYPE='P' One of the following values:</p> <ul style="list-style-type: none"> • 'D7C3C1D7D5D9E6C6' for PCAPNRWF • 'D7C3C1D7D5D7C7C6' for PCAPNPGF
TYPE	CHAR(1) NOT NULL	<p>The type of statistics:</p> <p>C Cardinality</p> <p>F Frequent value</p> <p>H Histogram</p> <p>T Real-time table cardinality</p> <p>L Real-time column cardinality (unique index only)</p> <p>P real-time partition cardinality</p>

Table 406. Descriptions of columns in DSN_COLDIST_TABLE (continued)

Column name	Data Type	Description
CARDF	FLOAT NOT NULL	<p>For TYPE='C', the number of distinct values for the column group. For TYPE='H', the number of distinct values for the column group in a quantile indicated by the value of the QUANTILENO column.</p> <p>For TYPE='T', a value related to real-time statistics table values that are determined by the COLVALUE column.</p> <p>For TYPE='L', a value related to a real-time statistics column value that is determined by the COLVALUE column. The QUANTILENO column contains the column number. The NAME column contains the column name.</p> <p>For TYPE='P' a value related to real-time statistics partition value that is determined by the COLVALUE column. The QUANTILENO column contains the partition number.</p>
COLGROUPCOLNO	VARCHAR(254) NOT NULL FOR BIT DATA	The identity of the set of columns associated with the statistics. If the statistics are only associated with a single column, the field contains a zero length. Otherwise, the field is an array of SMALLINT column numbers with a dimension equal to the value in the NUMCOLUMNS column. This is an updatable column.
NUMCOLUMNS	SMALLINT NOT NULL	Identifies the number of columns associated with the statistics.
FREQUENCYF	FLOAT NOT NULL	The percentage of rows in the table with the value that is specified in the COLVALUE column when the number is multiplied by 100. For example, a value of '1' indicates 100%. A value of '.153' indicates 15.3%.
QUANTILENO	SMALLINT NOT NULL	<p>The ordinary sequence number of a quantile in the whole consecutive value range, from low to high. This column is not updatable.</p> <p>For TYPE='L', this column contains the column number.</p> <p>For TYPE='P', the column contains the partition number.</p>
LOWVALUE	VARCHAR(2000) NOT NULL FOR BIT DATA	For TYPE='H', this is the lower bound for the quantile indicated by the value of the QUANTILENO column. Not used if the value of the TYPE column is not 'H'. This column is not updatable.

Table 406. Descriptions of columns in DSN_COLDIST_TABLE (continued)

Column name	Data Type	Description
HIGHVALUE	VARCHAR(2000) NOT NULL FOR BIT DATA	For TYPE='H', this is the higher bound for the quantile indicated by the value of the QUANTILENO column. This column is not used if the value of the TYPE column is not 'H'. This column is not updatable.
EXPANSION_REASON	CHAR(2) NOT NULL WITH DEFAULT	<p>This column applies only to statements that reference archive tables or temporal tables. For other statements, this column is blank.</p> <p>Indicates the effect of the CURRENT TEMPORAL BUSINESS_TIME special register, the CURRENT TEMPORAL SYSTEM_TIME special register, and the SYSIBMADM.GET_ARCHIVE built-in global variable. These items are controlled by the BUSTIMESENSITIVE, SYSTIMESENSITIVE, and ARCHIVESENSITIVE bind options.</p> <p>Db2 implicitly adds certain syntax to the query if one of the following conditions are true:</p> <ul style="list-style-type: none"> • The SYSIBMADM.GET_ARCHIVE global variable is set to Y and the ARCHIVESENSITIVE bind option is set to YES • The CURRENT TEMPORAL BUSINESS_TIME special register is not null and the BUSTIMESENSITIVE bind option is set to YES • The CURRENT TEMPORAL SYSTEM_TIME special register is not null and the SYSTIMESENSITIVE bind option is set to YES

Table 406. Descriptions of columns in DSN_COLDIST_TABLE (continued)

Column name	Data Type	Description
EXPANSION_REASON (continued)		<p>This column can have one of the following values:</p> <p>'A' The query contains implicit query transformation as a result of the SYSIBMADM.GET_ARCHIVE built-in global variable.</p> <p>'B' The query contains implicit query transformation as a result of the CURRENT TEMPORAL BUSINESS_TIME special register.</p> <p>'S' The query contains implicit query transformation as a result of the CURRENT TEMPORAL SYSTEM_TIME special register.</p> <p>'SB' The query contains implicit query transformation as a result of the CURRENT TEMPORAL SYSTEM_TIME special register and the CURRENT TEMPORAL BUSINESS_TIME special register.</p> <p>blank The query does not contain implicit query transformation.</p>
PER_STMT_ID	BIGINT NOT NULL	<p>The persistent statement identifier for SQL statements in Db2 catalog tables.</p> <p>For example, this column corresponds to the following catalog table columns that identify SQL statements:</p> <ul style="list-style-type: none"> • STMT_ID in SYSIBM.SYSPACKSTMT, for SQL statements in packages. • SDQ_STMT_ID in SYSIBM.SYSDYNQUERY, for stabilized dynamic SQL statements.
AP_PLANID	CHAR(16) FOR BIT DATA	A unique identifier for BIND or PREPARE optimizations for an SQL statement, in the form of an extended timestamp value.

◀ PSPI

Related concepts

[Dynamic collection of index filtering estimates \(Db2 Performance\)](#)

DSN_DETCOST_TABLE

The detailed cost table, DSN_DETCOST_TABLE, contains information about detailed cost estimation of the mini-plans in a query.

PSPi

Recommendation: Do not manually insert data into system-maintained EXPLAIN tables, and use care when deleting obsolete EXPLAIN table data. The data is intended to be manipulated only by the Db2 EXPLAIN function and optimization tools. Certain optimization tools depend on instances of the various EXPLAIN tables. Be careful not to delete data from or drop instances EXPLAIN tables that are created for these tools.

Qualifiers

Your subsystem or data sharing group can contain multiple instances of these tables that are qualified by user ID. These tables are populated with statement cost information when you issue the EXPLAIN statement or bind. They are also populated when you specify EXPLAIN(YES) or EXPLAIN(ONLY) in a BIND or REBIND command. SQL optimization tools might also create EXPLAIN tables that are qualified by a user ID. You can find the SQL statement for creating an instance of these tables in member DSNTESC of the SDSNSAMP library.

Sample CREATE TABLE statement

You can find a sample CREATE TABLE statement for each EXPLAIN table in member DSNTESC of the *prefix*.SDSNSAMP library. You can call the ADMIN_EXPLAIN_MAINT stored procedure to create EXPLAIN tables, upgrade them to the format for the current Db2 release, or complete other maintenance tasks. See [“ADMIN_EXPLAIN_MAINT stored procedure” on page 751](#) for information about using the *action* input parameter to request each of these tasks.

Column descriptions

The following table describes the columns of DSN_DETCOST_TABLE.

Table 407. DSN_DETCOST_TABLE description

Column name	Data type	Description
QUERYNO	INTEGER NOT NULL	<p>A number that identifies the statement that is being explained. The origin of the value depends on the context of the row:</p> <p>For rows produced by EXPLAIN statements The number specified in the QUERYNO clause, which is an optional part of the SELECT, INSERT, UPDATE, MERGE, and DELETE statement syntax.</p> <p>For rows not produced by EXPLAIN statements Db2 assigns a number that is based on the line number of the SQL statement in the source program.</p> <p>When the values of QUERYNO are based on the statement number in the source program, values that exceed 32767 are reported as 0. However, in certain rare cases, the value is not guaranteed to be unique.</p> <p>When the SQL statement is embedded in a compiled SQL function, native SQL procedure, or advanced trigger, if the QUERYNO clause is specified, its value is used by Db2. Otherwise Db2 assigns a number based on the line number of the SQL statement in the compiled SQL function, native SQL procedure, or advanced trigger.</p>

Table 407. DSN_DETCOST_TABLE description (continued)

Column name	Data type	Description
QBLOCKNO	SMALLINT NOT NULL	A number that identifies each query block within a query. The value of the numbers are not in any particular order, nor are they necessarily consecutive.
APPLNAME	VARCHAR(24) NOT NULL	The name of the application plan for the row. Applies only to embedded EXPLAIN statements that are executed from a plan or to statements that are explained when binding a plan. A blank indicates that the column is not applicable. When the SQL statement is embedded in a compiled SQL function, native SQL procedure, or advanced trigger, this column is not used, and is blank.
PROGNAME	VARCHAR(128) NOT NULL	The name of the program or package containing the statement being explained. Applies only to embedded EXPLAIN statements and to statements explained as the result of binding a plan or package. A blank indicates that the column is not applicable. When the SQL statement is embedded in a compiled SQL function or native SQL procedure, this column indicates the specific name of the compiled SQL function or native SQL procedure. When the SQL statement is embedded in an advanced trigger, this column contains the name of the trigger.
PLANNO	SMALLINT NOT NULL	The plan number, a number used to identify each mini-plan with a query block.
OPENIO	FLOAT(4) NOT NULL	The Do-at-open IO cost for non-correlated subquery.
OPENCPU	FLOAT(4) NOT NULL	The Do-at-open CPU cost for non-correlated subquery.
OPENCOST	FLOAT(4) NOT NULL	The Do-at-open total cost for non-correlated subquery.
DMIO	FLOAT(4) NOT NULL	IBM internal use only.
DMCPU	FLOAT(4) NOT NULL	IBM internal use only.
DMTOT	FLOAT(4) NOT NULL	IBM internal use only.
SUBQIO	FLOAT(4) NOT NULL	IBM internal use only.
SUBQCOST	FLOAT(4) NOT NULL	IBM internal use only.
BASEIO	FLOAT(4) NOT NULL	IBM internal use only.
BASECPU	FLOAT(4) NOT NULL	IBM internal use only.
BASETOT	FLOAT(4) NOT NULL	IBM internal use only.

Table 407. DSN_DETCOST_TABLE description (continued)

Column name	Data type	Description
ONECOMPROWS	FLOAT(4) NOT NULL	The number of rows qualified after applying local predicates.
IMLEAF	FLOAT(4) NOT NULL	The number of index leaf pages scanned by Data Manager.
IMIO	FLOAT(4) NOT NULL	IBM internal use only.
IMPREFH	CHAR(2) NOT NULL	IBM internal use only.
IMMPRED	INTEGER NOT NULL	IBM internal use only.
IMFF	FLOAT(4) NOT NULL	The filter factor of matching predicates only.
IMSRPRED	INTEGER NOT NULL	IBM internal use only.
IMFFADJ	FLOAT(4) NOT NULL	The filter factor of matching and screening predicates.
IMSCANCST	FLOAT(4) NOT NULL	IBM internal use only.
IMROWCST	FLOAT(4) NOT NULL	IBM internal use only.
IMPAGECST	FLOAT(4) NOT NULL	IBM internal use only.
IMRIDSORT	FLOAT(4) NOT NULL	IBM internal use only.
IMMERCST	FLOAT(4) NOT NULL	IBM internal use only.
IMCPU	FLOAT(4) NOT NULL	IBM internal use only.
IMTOT	FLOAT(4) NOT NULL	IBM internal use only.
IMSEQNO	SMALLINT NOT NULL	IBM internal use only.
DMPEREFH	FLOAT(4) NOT NULL	IBM internal use only.
DMCLUDIO	FLOAT(4) NOT NULL	IBM internal use only.
DMPREDS	INTEGER NOT NULL	IBM internal use only.
DMSROWS	FLOAT(4) NOT NULL	IBM internal use only.
DMSCANCST	FLOAT(4) NOT NULL	IBM internal use only.

Table 407. DSN_DETCOST_TABLE description (continued)

Column name	Data type	Description
DMCOLS	FLOAT(4) NOT NULL	The number of data manager columns.
DMROWS	FLOAT(4) NOT NULL	The number of data manager rows returned (after all stage 1 predicates are applied).
RDSROWCST	FLOAT(4) NOT NULL	IBM internal use only.
DMPAGECST	FLOAT(4) NOT NULL	IBM internal use only.
DMDATAIO	FLOAT(4) NOT NULL	IBM internal use only.
DMDATAIO	FLOAT(4) NOT NULL	IBM internal use only.
DMDATACPU	FLOAT(4) NOT NULL	IBM internal use only.
DMDATACPU	FLOAT(4) NOT NULL	IBM internal use only.
RDSROW	FLOAT(4) NOT NULL	The number of RDS rows returned (after all stage 1 and stage 2 predicates are applied).
SNCOLS	SMALLINT NOT NULL	The number of columns as sort input for new table.
SNROWS	FLOAT(4) NOT NULL	The number of rows as sort input for new table.
SNRECSZ	INTEGER NOT NULL	The record size for new table.
SNPAGES	FLOAT(4) NOT NULL	The page size for new table.
SNRUNS	FLOAT(4) NOT NULL	The number of runs generated for sort of new table.
SNMERGES	FLOAT(4) NOT NULL	The number of merges needed during sort.
SNIOCOST	FLOAT(4) NOT NULL	IBM internal use only.
SNCPUCOST	FLOAT(4) NOT NULL	IBM internal use only.
SNCOST	FLOAT(4) NOT NULL	IBM internal use only.
SNCSCANIO	FLOAT(4) NOT NULL	IBM internal use only.
SNSCANCPU	FLOAT(4) NOT NULL	IBM internal use only.
SNCCOLS	FLOAT(4) NOT NULL	The number of columns as sort input for Composite table.

Table 407. DSN_DETCOST_TABLE description (continued)

Column name	Data type	Description
SCROWS	FLOAT(4) NOT NULL	The number of rows as sort input for Composite Table.
SCRECSZ	FLOAT(4) NOT NULL	The record size for Composite table.
SCPAGES	FLOAT(4) NOT NULL	The page size for Composite table.
SCRUNS	FLOAT(4) NOT NULL	The number of runs generated during sort of composite.
SCMERGES	FLOAT(4) NOT NULL	The number of merges needed during sort of composite.
SCIOCOST	FLOAT(4) NOT NULL	IBM internal use only.
SCCPU COST	FLOAT(4) NOT NULL	IBM internal use only.
SCCOST	FLOAT(4) NOT NULL	IBM internal use only.
SCSCANIO	FLOAT(4) NOT NULL	IBM internal use only.
SCSCANCPU	FLOAT(4) NOT NULL	IBM internal use only.
SCSCANCOST	FLOAT(4) NOT NULL	IBM internal use only.
COMPCARD	FLOAT(4) NOT NULL	The total composite cardinality.
COMPIOCOST	FLOAT(4) NOT NULL	IBM internal use only.
COMPCPUCOST	FLOAT(4) NOT NULL	IBM internal use only.
COMPCOST	FLOAT(4) NOT NULL	The total cost.
JOINCOLS	SMALLINT NOT NULL	IBM internal use only.
EXPLAIN_TIME	TIMESTAMP NOT NULL	The time when the EXPLAIN information was captured: All cached statements When the statement entered the cache, in the form of a full-precision timestamp value. Non-cached static statements When the statement was bound, in the form of a full precision timestamp value. Non-cached dynamic statements When EXPLAIN was executed, in the form of a value equivalent to a CHAR(16) representation of the time appended by 4 zeros.

Table 407. DSN_DETCOST_TABLE description (continued)

Column name	Data type	Description
COSTBLK	INTEGER NOT NULL	IBM internal use only.
COSTSTOR	INTEGER NOT NULL	IBM internal use only.
MPBLK	INTEGER NOT NULL	IBM internal use only.
MPSTOR	INTEGER NOT NULL	IBM internal use only.
COMPOSITES	INTEGER NOT NULL	IBM internal use only.
CLIPPED	INTEGER NOT NULL	IBM internal use only.
TABREF	VARCHAR(64) NOT NULL FOR BIT DATA	IBM internal use only.
MAX_COMPOSITES	INTEGER NOT NULL	IBM internal use only.
MAX_STOR	INTEGER NOT NULL	IBM internal use only.
MAX_CPU	INTEGER NOT NULL	IBM internal use only.
MAX_ELAP	INTEGER NOT NULL	IBM internal use only.
TBL_JOINED_THRESH	INTEGER NOT NULL	IBM internal use only.
STOR_USED	INTEGER NOT NULL	IBM internal use only.
CPU_USED	INTEGER NOT NULL	IBM internal use only.
ELAPSED	INTEGER NOT NULL	IBM internal use only.
MIN_CARD_KEEP	FLOAT(4) NOT NULL	IBM internal use only.
MAX_CARD_KEEP	FLOAT(4) NOT NULL	IBM internal use only.
MIN_COST_KEEP	FLOAT(4) NOT NULL	IBM internal use only.
MAX_COST_KEEP	FLOAT(4) NOT NULL	IBM internal use only.
MIN_VALUE_KEEP	FLOAT(4) NOT NULL	IBM internal use only.

Table 407. DSN_DETCOST_TABLE description (continued)

Column name	Data type	Description
MIN_VALUE_CARD_KEEP	FLOAT(4) NOT NULL	IBM internal use only.
MIN_VALUE_COST_KEEP	FLOAT(4) NOT NULL	IBM internal use only.
MIN_CARD_CLIP	FLOAT(4) NOT NULL	IBM internal use only.
MAX_CARD_CLIP	FLOAT(4) NOT NULL	IBM internal use only.
MIN_COST_CLIP	FLOAT(4) NOT NULL	IBM internal use only.
MAX_COST_CLIP	FLOAT(4) NOT NULL	IBM internal use only.
MIN_VALUE_CLIP	FLOAT(4) NOT NULL	IBM internal use only.
MIN_VALUE_CARD_CLIP	FLOAT(4) NOT NULL	IBM internal use only.
MIN_VALUE_COST_CLIP	FLOAT(4) NOT NULL	IBM internal use only.
MAX_VALUE_CLIP	FLOAT(4) NOT NULL	IBM internal use only.
MAX_VALUE_CARD_CLIP	FLOAT(4) NOT NULL	IBM internal use only.
MAX_VALUE_COST_CLIP	FLOAT(4) NOT NULL	IBM internal use only.
GROUP_MEMBER	VARCHAR(24) NOT NULL	The member name of the Db2 that executed EXPLAIN. The column is blank if the Db2 subsystem was not in a data sharing environment when EXPLAIN was executed.
PSEQIOCOST	FLOAT(4) NOT NULL	IBM internal use only.
PSEQIOCOST	FLOAT(4) NOT NULL	IBM internal use only.
PSEQCPCUCOST	FLOAT(4) NOT NULL	IBM internal use only.
PSEQCOST	FLOAT(4) NOT NULL	IBM internal use only.
PADJIOCOST	FLOAT(4) NOT NULL	IBM internal use only.
PADJCPUCOST	FLOAT(4) NOT NULL	IBM internal use only.
PADJCOST	FLOAT(4) NOT NULL	IBM internal use only.

Table 407. DSN_DETCOST_TABLE description (continued)

Column name	Data type	Description
UNCERTAINTY	FLOAT(4) NOT NULL WITH DEFAULT	Describes the uncertainty factor of inner table index access. It is aggregated from uncertainty of inner table probing predicates. A larger value indicates a higher uncertainty. 0 indicates no uncertainty or uncertainty not considered.
UNCERTAINTY_1T	FLOAT(4) NOT NULL WITH DEFAULT	Describes the uncertainty factor of ONECOMPROWS column of the table. It is aggregated from all local predicates on the table. A larger value indicates a higher uncertainty. 0 indicates no uncertainty or uncertainty not considered.
SECTNOI	INTEGER NOT NULL WITH DEFAULT	The section number of the statement. The value is taken from the same column in SYSPACKSTMT or SYSSTMT tables and can be used to join tables to reconstruct the access path for the statement. This column is applicable only for static statements. The default value of -1 indicates EXPLAIN information that was captured in DB2 9 or earlier.
COLLID	VARCHAR(128) NOT NULL	The collection ID: 'DSNEXPLAINMODEYES' The row originates from an application that specifies YES for the value of the CURRENT EXPLAIN MODE special register. 'DSNEXPLAINMODEEXPLAIN' The row originates from an application that specifies EXPLAIN for the value of the CURRENT EXPLAIN MODE special register. When the SQL statement is embedded in a compiled SQL function, native SQL procedure, or advanced trigger, this column indicates the schema name of the compiled SQL function, native SQL procedure, or advanced trigger.
VERSION	VARCHAR(128) NOT NULL WITH DEFAULT	The version identifier for the package. Applies only to an embedded EXPLAIN statement executed from a package or to a statement that is explained when binding a package. A blank indicates that the column is not applicable. When the SQL statement is embedded in a compiled SQL function, native SQL procedure, or advanced trigger, this column indicates the schema name of the compiled SQL function, native SQL procedure, or advanced trigger.
IMNP	FLOAT(4) NOT NULL WITH DEFAULT	IBM internal use only.
DMNP	FLOAT(4) NOT NULL WITH DEFAULT	IBM internal use only.
IMJC	FLOAT(4) NOT NULL WITH DEFAULT	IBM internal use only.
IMFC	FLOAT(4) NOT NULL WITH DEFAULT	IBM internal use only.

Table 407. DSN_DETCOST_TABLE description (continued)

Column name	Data type	Description
IMJBC	FLOAT(4) NOT NULL WITH DEFAULT	IBM internal use only.
IMJFC	FLOAT(4) NOT NULL WITH DEFAULT	IBM internal use only.
CRED	INTEGER NOT NULL WITH DEFAULT	IBM internal use only.
IXSCAN_SKIP_DUPS	CHAR(1) NOT NULL WITH DEFAULT 'N'	Whether duplicate index key values are skipped during an index scan. 'Y' Duplicate key values are skipped. 'N' Duplicate key values are not skipped.
IXSCAN_SKIP_SCREEN	CHAR(1) NOT NULL WITH DEFAULT 'N'	Whether key ranges that are disqualified by index screening predicates are skipped during an index scan. 'Y' Disqualified key ranges are skipped. 'N' Key ranges are not skipped.
EARLY_OUT	CHAR(1) NOT NULL WITH DEFAULT ''	Whether fetching from the table stops after the first qualified row. 'Y' Internal fetching stops after the first qualified row 'N' Internal fetching continues after the first qualified row. blank The EXPLAIN information was captured in a previous release, or the EXPLAIN information was captured for a package that was bound in a previous release.

Table 407. DSN_DETCOST_TABLE description (continued)

Column name	Data type	Description
EXPANSION_REASON	CHAR(2) NOT NULL WITH DEFAULT	<p>This column applies only to statements that reference archive tables or temporal tables. For other statements, this column is blank.</p> <p>Indicates the effect of the CURRENT TEMPORAL BUSINESS_TIME special register, the CURRENT TEMPORAL SYSTEM_TIME special register, and the SYSIBMADM.GET_ARCHIVE built-in global variable. These items are controlled by the BUSTIMESENSITIVE, SYSTIMESENSITIVE, and ARCHIVESENSITIVE bind options.</p> <p>Db2 implicitly adds certain syntax to the query if one of the following conditions are true:</p> <ul style="list-style-type: none"> • The SYSIBMADM.GET_ARCHIVE global variable is set to Y and the ARCHIVESENSITIVE bind option is set to YES • The CURRENT TEMPORAL BUSINESS_TIME special register is not null and the BUSTIMESENSITIVE bind option is set to YES • The CURRENT TEMPORAL SYSTEM_TIME special register is not null and the SYSTIMESENSITIVE bind option is set to YES <p>This column can have one of the following values:</p> <p>'A' The query contains implicit query transformation as a result of the SYSIBMADM.GET_ARCHIVE built-in global variable.</p> <p>'B' The query contains implicit query transformation as a result of the CURRENT TEMPORAL BUSINESS_TIME special register.</p> <p>'S' The query contains implicit query transformation as a result of the CURRENT TEMPORAL SYSTEM_TIME special register.</p> <p>'SB' The query contains implicit query transformation as a result of the CURRENT TEMPORAL SYSTEM_TIME special register and the CURRENT TEMPORAL BUSINESS_TIME special register.</p> <p>blank The query does not contain implicit query transformation.</p>
BLOCK_FETCH	CHAR(1) NOT NULL WITH DEFAULT 'N'	<p>Indicates whether block fetch was used for the query.</p> <p>'Y' Block fetch was used.</p> <p>'N' Block fetch was not used.</p>

Table 407. DSN_DETCOST_TABLE description (continued)

Column name	Data type	Description
PER_STMT_ID	BIGINT NOT NULL	<p>The persistent statement identifier for SQL statements in Db2 catalog tables.</p> <p>For example, this column corresponds to the following catalog table columns that identify SQL statements:</p> <ul style="list-style-type: none"> • STMT_ID in SYSIBM.SYSPACKSTMT, for SQL statements in packages. • SDQ_STMT_ID in SYSIBM.SYSDYNQUERY, for stabilized dynamic SQL statements.
AP_PLANID	CHAR(16) FOR BIT DATA	A unique identifier for BIND or PREPARE optimizations for an SQL statement, in the form of an extended timestamp value.



Related information

[IBM Db2 Analytics Accelerator for z/OS documentation](#)

DSN_FILTER_TABLE

The filter table, DSN_FILTER_TABLE, contains information about how predicates are used during query processing.



Recommendation: Do not manually insert data into system-maintained EXPLAIN tables, and use care when deleting obsolete EXPLAIN table data. The data is intended to be manipulated only by the Db2 EXPLAIN function and optimization tools. Certain optimization tools depend on instances of the various EXPLAIN tables. Be careful not to delete data from or drop instances EXPLAIN tables that are created for these tools.

Qualifiers

Your subsystem or data sharing group can contain multiple instances of these tables that are qualified by user ID. These tables are populated with statement cost information when you issue the EXPLAIN statement or bind. They are also populated when you specify EXPLAIN(YES) or EXPLAIN(ONLY) in a BIND or REBIND command. SQL optimization tools might also create EXPLAIN tables that are qualified by a user ID. You can find the SQL statement for creating an instance of these tables in member DSNTESC of the SDSNSAMP library.

Sample CREATE TABLE statement

You can find a sample CREATE TABLE statement for each EXPLAIN table in member DSNTESC of the *prefix*.SDSNSAMP library. You can call the ADMIN_EXPLAIN_MAINT stored procedure to create EXPLAIN tables, upgrade them to the format for the current Db2 release, or complete other maintenance tasks. See [“ADMIN_EXPLAIN_MAINT stored procedure” on page 751](#) for information about using the *action* input parameter to request each of these tasks.

Column descriptions

The following table describes the columns of DSN_FILTER_TABLE.

Table 408. DSN_FILTER_TABLE description

Column name	Data type	Description
QUERYNO	INTEGER NOT NULL	<p>A number that identifies the statement that is being explained. The origin of the value depends on the context of the row:</p> <p>For rows produced by EXPLAIN statements The number specified in the QUERYNO clause, which is an optional part of the SELECT, INSERT, UPDATE, MERGE, and DELETE statement syntax.</p> <p>For rows not produced by EXPLAIN statements Db2 assigns a number that is based on the line number of the SQL statement in the source program.</p> <p>When the values of QUERYNO are based on the statement number in the source program, values that exceed 32767 are reported as 0. However, in certain rare cases, the value is not guaranteed to be unique.</p> <p>When the SQL statement is embedded in a compiled SQL function, native SQL procedure, or advanced trigger, if the QUERYNO clause is specified, its value is used by Db2. Otherwise Db2 assigns a number based on the line number of the SQL statement in the compiled SQL function, native SQL procedure, or advanced trigger.</p>
QBLOCKNO	SMALLINT NOT NULL	A number that identifies each query block within a query. The value of the numbers are not in any particular order, nor are they necessarily consecutive.
PLANNO	SMALLINT	The plan number, a number used to identify each miniplan with a query block.
APPLNAME	VARCHAR(24) NOT NULL	<p>The name of the application plan for the row. Applies only to embedded EXPLAIN statements that are executed from a plan or to statements that are explained when binding a plan. A blank indicates that the column is not applicable.</p> <p>When the SQL statement is embedded in a compiled SQL function, native SQL procedure, or advanced trigger, this column is not used, and is blank.</p>
PROGNAME	VARCHAR(128) NOT NULL	<p>The name of the program or package containing the statement being explained. Applies only to embedded EXPLAIN statements and to statements explained as the result of binding a plan or package. A blank indicates that the column is not applicable.</p> <p>When the SQL statement is embedded in a compiled SQL function or native SQL procedure, this column indicates the specific name of the compiled SQL function or native SQL procedure. When the SQL statement is embedded in an advanced trigger, this column contains the name of the trigger.</p>

Table 408. DSN_FILTER_TABLE description (continued)

Column name	Data type	Description
COLLID	VARCHAR(128) NOT NULL WITH DEFAULT	The collection ID: 'DSNEXPLAINMODEYES' The row originates from an application that specifies YES for the value of the CURRENT EXPLAIN MODE special register. 'DSNEXPLAINMODEEXPLAIN' The row originates from an application that specifies EXPLAIN for the value of the CURRENT EXPLAIN MODE special register. When the SQL statement is embedded in a compiled SQL function, native SQL procedure, or advanced trigger, this column indicates the schema name of the compiled SQL function, native SQL procedure, or advanced trigger.
ORDERNO	INTEGER NOT NULL	The sequence number of evaluation. Indicates the order in which the predicate is applied within each stage
PREDNO	INTEGER NOT NULL	The predicate number, a number used to identify a predicate within a query.
STAGE	CHAR(9) NOT NULL	The processing stage in which the predicate is evaluated: MATCHING During the index matching stage. SCREENING During the index screening stage. PAGERANGE Db2 used page range screening to limit the number of partitions that were accessed to evaluate the predicate in a join context. STAGE1 During stage 1 processing, after data page access. STAGE2 During stage 2 processing on the returned data rows.
ORDERCLASS	INTEGER NOT NULL	IBM internal use only.
EXPLAIN_TIME	TIMESTAMP NOT NULL	The time when the EXPLAIN information was captured: All cached statements When the statement entered the cache, in the form of a full-precision timestamp value. Non-cached static statements When the statement was bound, in the form of a full precision timestamp value. Non-cached dynamic statements When EXPLAIN was executed, in the form of a value equivalent to a CHAR(16) representation of the time appended by 4 zeros.
MIXOPSEQNO	SMALLINT NOT NULL	IBM internal use only.
REEVAL	CHAR(1) NOT NULL	IBM internal use only.

Table 408. DSN_FILTER_TABLE description (continued)

Column name	Data type	Description
GROUP_MEMBER	VARCHAR(24) NOT NULL	The member name of the Db2 that executed EXPLAIN. The column is blank if the Db2 subsystem was not in a data sharing environment when EXPLAIN was executed.
SECTNOI	INTEGER NOT NULL WITH DEFAULT	The section number of the statement. The value is taken from the same column in SYSPACKSTMT or SYSSTMT tables and can be used to join tables to reconstruct the access path for the statement. This column is applicable only for static statements. The default value of -1 indicates EXPLAIN information that was captured in DB2 9 or earlier.
VERSION	VARCHAR(122) NOT NULL WITH DEFAULT	<p>The version identifier for the package. Applies only to an embedded EXPLAIN statement executed from a package or to a statement that is explained when binding a package.</p> <p>If the value is not blank, the value is the same as the VERSION value for the package that was used to create this EXPLAIN table row.</p> <p>The value is blank for a statement in:</p> <ul style="list-style-type: none"> • A package for a basic trigger (TYPE='T') • A package for an application that was precompiled without SQL processing option VERSION • A package that was precompiled with an empty string for the VERSION value (TYPE=blank) <p>When the SQL statement is embedded in a compiled SQL function or native SQL procedure, this column indicates the version identifier of the function or procedure. When the SQL statement is embedded in an advanced trigger body, this column is not used and will be blank.</p>
PUSHDOWN	CHAR(1) NOT NULL WITH DEFAULT	<p>Whether the predicate is pushed down the Index Manager or Data Manager subcomponents for evaluation:</p> <p>'I' The Index Manager subcomponent evaluates the predicate.</p> <p>'D' The Data Manager subcomponent evaluates the predicate.</p> <p>blank The predicate is not pushed down for evaluation.</p>

Table 408. DSN_FILTER_TABLE description (continued)

Column name	Data type	Description
EXPANSION_REASON	CHAR(2) NOT NULL WITH DEFAULT	<p>This column applies only to statements that reference archive tables or temporal tables. For other statements, this column is blank.</p> <p>Indicates the effect of the CURRENT TEMPORAL BUSINESS_TIME special register, the CURRENT TEMPORAL SYSTEM_TIME special register, and the SYSIBMADM.GET_ARCHIVE built-in global variable. These items are controlled by the BUSTIMESENSITIVE, SYSTIMESENSITIVE, and ARCHIVESENSITIVE bind options.</p> <p>Db2 implicitly adds certain syntax to the query if one of the following conditions are true:</p> <ul style="list-style-type: none"> • The SYSIBMADM.GET_ARCHIVE global variable is set to Y and the ARCHIVESENSITIVE bind option is set to YES • The CURRENT TEMPORAL BUSINESS_TIME special register is not null and the BUSTIMESENSITIVE bind option is set to YES • The CURRENT TEMPORAL SYSTEM_TIME special register is not null and the SYSTIMESENSITIVE bind option is set to YES <p>This column can have one of the following values:</p> <p>'A' The query contains implicit query transformation as a result of the SYSIBMADM.GET_ARCHIVE built-in global variable.</p> <p>'B' The query contains implicit query transformation as a result of the CURRENT TEMPORAL BUSINESS_TIME special register.</p> <p>'S' The query contains implicit query transformation as a result of the CURRENT TEMPORAL SYSTEM_TIME special register.</p> <p>'SB' The query contains implicit query transformation as a result of the CURRENT TEMPORAL SYSTEM_TIME special register and the CURRENT TEMPORAL BUSINESS_TIME special register.</p> <p>blank The query does not contain implicit query transformation.</p>
PER_STMT_ID	BIGINT NOT NULL	<p>The persistent statement identifier for SQL statements in Db2 catalog tables.</p> <p>For example, this column corresponds to the following catalog table columns that identify SQL statements:</p> <ul style="list-style-type: none"> • STMT_ID in SYSIBM.SYSPACKSTMT, for SQL statements in packages. • SDQ_STMT_ID in SYSIBM.SYSDYNQUERY, for stabilized dynamic SQL statements.
AP_PLANID	CHAR(16) FOR BIT DATA	A unique identifier for BIND or PREPARE optimizations for an SQL statement, in the form of an extended timestamp value.

DSN_FUNCTION_TABLE

The function table, DSN_FUNCTION_TABLE, contains descriptions of functions that are used in specified SQL statements.

PSPI

Recommendation: Do not manually insert data into system-maintained EXPLAIN tables, and use care when deleting obsolete EXPLAIN table data. The data is intended to be manipulated only by the Db2 EXPLAIN function and optimization tools. Certain optimization tools depend on instances of the various EXPLAIN tables. Be careful not to delete data from or drop instances EXPLAIN tables that are created for these tools.

Qualifiers

Your subsystem or data sharing group can contain multiple instances of these tables that are qualified by user ID. These tables are populated with statement cost information when you issue the EXPLAIN statement or bind. They are also populated when you specify EXPLAIN(YES) or EXPLAIN(ONLY) in a BIND or REBIND command. SQL optimization tools might also create EXPLAIN tables that are qualified by a user ID. You can find the SQL statement for creating an instance of these tables in member DSNTESC of the SDSNSAMP library.

Sample CREATE TABLE statement

You can find a sample CREATE TABLE statement for each EXPLAIN table in member DSNTESC of the *prefix*.SDSNSAMP library. You can call the ADMIN_EXPLAIN_MAINT stored procedure to create EXPLAIN tables, upgrade them to the format for the current Db2 release, or complete other maintenance tasks. See [“ADMIN_EXPLAIN_MAINT stored procedure” on page 751](#) for information about using the *action* input parameter to request each of these tasks.

Column descriptions

PSPI

The following table describes the columns of DSN_FUNCTION_TABLE.

Table 409. Descriptions of columns in DSN_FUNCTION_TABLE

Column name	Data type	Description
QUERYNO	INTEGER NOT NULL WITH DEFAULT	<p>A number that identifies the statement that is being explained. The origin of the value depends on the context of the row:</p> <p>For rows produced by EXPLAIN statements The number specified in the QUERYNO clause, which is an optional part of the SELECT, INSERT, UPDATE, MERGE, and DELETE statement syntax.</p> <p>For rows not produced by EXPLAIN statements Db2 assigns a number that is based on the line number of the SQL statement in the source program.</p> <p>When the values of QUERYNO are based on the statement number in the source program, values that exceed 32767 are reported as 0. However, in certain rare cases, the value is not guaranteed to be unique.</p> <p>When the SQL statement is embedded in a compiled SQL function, native SQL procedure, or advanced trigger, if the QUERYNO clause is specified, its value is used by Db2. Otherwise Db2 assigns a number based on the line number of the SQL statement in the compiled SQL function, native SQL procedure, or advanced trigger.</p>
QBLOCKNO	INTEGER NOT NULL WITH DEFAULT	<p>A number that identifies each query block within a query. The value of the numbers are not in any particular order, nor are they necessarily consecutive.</p>
APPLNAME	VARCHAR(24) NOT NULL WITH DEFAULT	<p>The name of the application plan for the row. Applies only to embedded EXPLAIN statements that are executed from a plan or to statements that are explained when binding a plan. A blank indicates that the column is not applicable.</p> <p>When the SQL statement is embedded in a compiled SQL function, native SQL procedure, or advanced trigger, this column is not used, and is blank.</p>
PROGNAME	VARCHAR(128) NOT NULL WITH DEFAULT	<p>The name of the program or package containing the statement being explained. Applies only to embedded EXPLAIN statements and to statements explained as the result of binding a plan or package. A blank indicates that the column is not applicable.</p> <p>When the SQL statement is embedded in a compiled SQL function or native SQL procedure, this column indicates the specific name of the compiled SQL function or native SQL procedure. When the SQL statement is embedded in an advanced trigger, this column contains the name of the trigger.</p>

Table 409. Descriptions of columns in DSN_FUNCTION_TABLE (continued)

Column name	Data type	Description
COLLID	VARCHAR(128) NOT NULL WITH DEFAULT	<p>The collection ID:</p> <p>'DSNDYNAMICSQLCACHE' The row originates from the dynamic statement cache.</p> <p>'DSNEXPLAINMODEYES' The row originates from an application that specifies YES for the value of the CURRENT EXPLAIN MODE special register.</p> <p>'DSNEXPLAINMODEEXPLAIN' The row originates from an application that specifies EXPLAIN for the value of the CURRENT EXPLAIN MODE special register.</p> <p>When the SQL statement is embedded in a compiled SQL function, native SQL procedure, or advanced trigger, this column indicates the schema name of the compiled SQL function, native SQL procedure, or advanced trigger.</p>
GROUP_MEMBER	VARCHAR(24) NOT NULL WITH DEFAULT	The member name of the Db2 that executed EXPLAIN. The column is blank if the Db2 subsystem was not in a data sharing environment when EXPLAIN was executed.
EXPLAIN_TIME	TIMESTAMP NOT NULL WITH DEFAULT	<p>The time when the EXPLAIN information was captured:</p> <p>All cached statements When the statement entered the cache, in the form of a full-precision timestamp value.</p> <p>Non-cached static statements When the statement was bound, in the form of a full precision timestamp value.</p> <p>Non-cached dynamic statements When EXPLAIN was executed, in the form of a value equivalent to a CHAR(16) representation of the time appended by 4 zeros.</p>
SCHEMA_NAME	VARCHAR(128) NOT NULL WITH DEFAULT	The schema name of the function invoked in the explained statement.
FUNCTION_NAME	VARCHAR(128) NOT NULL WITH DEFAULT	The name of the function invoked in the explained statement.
SPEC_FUNC_NAME	VARCHAR(128) NOT NULL WITH DEFAULT	The specific name of the function invoked in the explained statement.
FUNCTION_TYPE	CHAR(2) NOT NULL WITH DEFAULT	<p>The type of function invoked in the explained statement. Possible values are:</p> <p>CU Column function</p> <p>SU Scalar function</p> <p>TU Table function</p>

Table 409. Descriptions of columns in DSN_FUNCTION_TABLE (continued)

Column name	Data type	Description
VIEW_CREATOR	VARCHAR(128) NOT NULL WITH DEFAULT	If the function specified in the FUNCTION_NAME column is referenced in a view definition, the creator of the view. Otherwise, blank.
VIEW_NAME	VARCHAR(128) NOT NULL WITH DEFAULT	If the function specified in the FUNCTION_NAME column is referenced in a view definition, the name of the view. Otherwise, blank.
PATH	VARCHAR(2048) NOT NULL WITH DEFAULT	The value of the SQL path that was used to resolve the schema name of the function.
FUNCTION_TEXT	VARCHAR(1500) NOT NULL WITH DEFAULT	The text of the function reference (the function name and parameters). If the function reference is over 100 bytes, this column contains the first 100 bytes. For functions specified in infix notation, FUNCTION_TEXT contains only the function name. For example, for a function named /, which overloads the SQL divide operator, if the function reference is A/B, FUNCTION_TEXT contains only /.
FUNC_VERSION	VARCHAR(122) NOT NULL WITH DEFAULT	For a version of a non-inline SQL scalar function, this column contains the version identifier. For all other cases, this column contains a zero length string. A version of a non-inline SQL scalar function is defined in the SYSIBM.SYSROUTINES table with ORIGIN='Q', FUNCTION_TYPE='S', INLINE='N', and VERSION column containing the version identifier.
SECURE	CHAR(1) NOT NULL WITH DEFAULT	Whether the user-defined function is secure.
SECTNOI	INTEGER NOT NULL WITH DEFAULT	The section number of the statement. The value is taken from the same column in SYSPACKSTMT or SYSSTMT tables and can be used to join tables to reconstruct the access path for the statement. This column is applicable only for static statements. The default value of -1 indicates EXPLAIN information that was captured in DB2 9 or earlier.
VERSION	VARCHAR(122) NOT NULL WITH DEFAULT	<p>The version identifier for the package. Applies only to an embedded EXPLAIN statement executed from a package or to a statement that is explained when binding a package.</p> <p>If the value is not blank, the value is the same as the VERSION value for the package that was used to create this EXPLAIN table row.</p> <p>The value is blank for a statement in:</p> <ul style="list-style-type: none"> • A package for a basic trigger (TYPE='T') • A package for an application that was precompiled without SQL processing option VERSION • A package that was precompiled with an empty string for the VERSION value (TYPE=blank) <p>When the SQL statement is embedded in a compiled SQL function or native SQL procedure, this column indicates the version identifier of the function or procedure. When the SQL statement is embedded in an advanced trigger body, this column is not used and will be blank.</p>

Table 409. Descriptions of columns in DSN_FUNCTION_TABLE (continued)

Column name	Data type	Description
EXPANSION_REASON	CHAR(2) NOT NULL WITH DEFAULT	<p>This column applies only to statements that reference archive tables or temporal tables. For other statements, this column is blank.</p> <p>Indicates the effect of the CURRENT TEMPORAL BUSINESS_TIME special register, the CURRENT TEMPORAL SYSTEM_TIME special register, and the SYSIBMADM.GET_ARCHIVE built-in global variable. These items are controlled by the BUSTIMESENSITIVE, SYSTIMESENSITIVE, and ARCHIVESENSITIVE bind options.</p> <p>Db2 implicitly adds certain syntax to the query if one of the following conditions are true:</p> <ul style="list-style-type: none"> • The SYSIBMADM.GET_ARCHIVE global variable is set to Y and the ARCHIVESENSITIVE bind option is set to YES • The CURRENT TEMPORAL BUSINESS_TIME special register is not null and the BUSTIMESENSITIVE bind option is set to YES • The CURRENT TEMPORAL SYSTEM_TIME special register is not null and the SYSTIMESENSITIVE bind option is set to YES <p>This column can have one of the following values:</p> <p>'A' The query contains implicit query transformation as a result of the SYSIBMADM.GET_ARCHIVE built-in global variable.</p> <p>'B' The query contains implicit query transformation as a result of the CURRENT TEMPORAL BUSINESS_TIME special register.</p> <p>'S' The query contains implicit query transformation as a result of the CURRENT TEMPORAL SYSTEM_TIME special register.</p> <p>'SB' The query contains implicit query transformation as a result of the CURRENT TEMPORAL SYSTEM_TIME special register and the CURRENT TEMPORAL BUSINESS_TIME special register.</p> <p>blank The query does not contain implicit query transformation.</p>
PER_STMT_ID	BIGINT NOT NULL	<p>The persistent statement identifier for SQL statements in Db2 catalog tables.</p> <p>For example, this column corresponds to the following catalog table columns that identify SQL statements:</p> <ul style="list-style-type: none"> • STMT_ID in SYSIBM.SYSPACKSTMT, for SQL statements in packages. • SDQ_STMT_ID in SYSIBM.SYSDYNQUERY, for stabilized dynamic SQL statements.
AP_PLANID	CHAR(16) FOR BIT DATA	Used to uniquely identify the BIND or PREPARE optimizations for a SQL statement. Contains an extended timestamp value.

Related tasks

Checking how Db2 resolves functions by using DSN_FUNCTION_TABLE (Db2 Application programming and SQL)

DSN_KEYTGTDIST_TABLE

The key-target distribution table contains non-uniform index expression statistic that are obtained dynamically by the Db2 optimizer.

PSPI

Recommendation: Do not manually insert data into system-maintained EXPLAIN tables, and use care when deleting obsolete EXPLAIN table data. The data is intended to be manipulated only by the Db2 EXPLAIN function and optimization tools. Certain optimization tools depend on instances of the various EXPLAIN tables. Be careful not to delete data from or drop instances EXPLAIN tables that are created for these tools.

Qualifiers

Your subsystem or data sharing group can contain multiple instances of these tables that are qualified by user ID. These tables are populated with statement cost information when you issue the EXPLAIN statement or bind. They are also populated when you specify EXPLAIN(YES) or EXPLAIN(ONLY) in a BIND or REBIND command. SQL optimization tools might also create EXPLAIN tables that are qualified by a user ID. You can find the SQL statement for creating an instance of these tables in member DSNTESC of the SDSNSAMP library.

Sample CREATE TABLE statement

You can find a sample CREATE TABLE statement for each EXPLAIN table in member DSNTESC of the *prefix*.SDSNSAMP library. You can call the ADMIN_EXPLAIN_MAINT stored procedure to create EXPLAIN tables, upgrade them to the format for the current Db2 release, or complete other maintenance tasks. See [“ADMIN_EXPLAIN_MAINT stored procedure” on page 751](#) for information about using the *action* input parameter to request each of these tasks.

COLUMN descriptions

The following table shows the descriptions of the columns in the DSN_KEYTGTDIST_TABLE table.

Table 410. Descriptions of columns in DSN_KEYTGTDIST_TABLE

Column name	Data Type	Description
QUERYNO	INTEGER NOT NULL	<p>A number that identifies the statement that is being explained. The origin of the value depends on the context of the row:</p> <p>For rows produced by EXPLAIN statements The number specified in the QUERYNO clause, which is an optional part of the SELECT, INSERT, UPDATE, MERGE, and DELETE statement syntax.</p> <p>For rows not produced by EXPLAIN statements Db2 assigns a number that is based on the line number of the SQL statement in the source program.</p> <p>When the values of QUERYNO are based on the statement number in the source program, values that exceed 32767 are reported as 0. However, in certain rare cases, the value is not guaranteed to be unique.</p> <p>When the SQL statement is embedded in a compiled SQL function, native SQL procedure, or advanced trigger, if the QUERYNO clause is specified, its value is used by Db2. Otherwise Db2 assigns a number based on the line number of the SQL statement in the compiled SQL function, native SQL procedure, or advanced trigger.</p>
APPLNAME	VARCHAR(128) NOT NULL	<p>The name of the application plan for the row. Applies only to embedded EXPLAIN statements that are executed from a plan or to statements that are explained when binding a plan. A blank indicates that the column is not applicable.</p> <p>When the SQL statement is embedded in a compiled SQL function, native SQL procedure, or advanced trigger, this column is not used, and is blank.</p>
PROGNAME	VARCHAR(128) NOT NULL	<p>The name of the program or package containing the statement being explained. Applies only to embedded EXPLAIN statements and to statements explained as the result of binding a plan or package. A blank indicates that the column is not applicable.</p> <p>When the SQL statement is embedded in a compiled SQL function or native SQL procedure, this column indicates the specific name of the compiled SQL function or native SQL procedure. When the SQL statement is embedded in an advanced trigger, this column contains the name of the trigger.</p>

Table 410. Descriptions of columns in DSN_KEYTGTDIST_TABLE (continued)

Column name	Data Type	Description
COLLID	VARCHAR(128) NOT NULL	<p>The collection ID:</p> <p>'DSNEXPLAINMODEYES' The row originates from an application that specifies YES for the value of the CURRENT EXPLAIN MODE special register.</p> <p>'DSNEXPLAINMODEEXPLAIN' The row originates from an application that specifies EXPLAIN for the value of the CURRENT EXPLAIN MODE special register.</p> <p>When the SQL statement is embedded in a compiled SQL function, native SQL procedure, or advanced trigger, this column indicates the schema name of the compiled SQL function, native SQL procedure, or advanced trigger.</p>
GROUP_MEMBER	VARCHAR(128) NOT NULL	<p>The member name of the Db2 that executed EXPLAIN. The column is blank if the Db2 subsystem was not in a data sharing environment when EXPLAIN was executed.</p>
SECTNOI	INTEGER NOT NULL	<p>The section number of the statement. The value is taken from the same column in SYSPACKSTMT or SYSSTMT tables and can be used to join tables to reconstruct the access path for the statement. This column is applicable only for static statements. The default value of -1 indicates EXPLAIN information that was captured in DB2 9 or earlier.</p>

Table 410. Descriptions of columns in DSN_KEYTGTDIST_TABLE (continued)

Column name	Data Type	Description
VERSION	VARCHAR(122) NOT NULL	<p>The version identifier for the package. Applies only to an embedded EXPLAIN statement executed from a package or to a statement that is explained when binding a package.</p> <p>If the value is not blank, the value is the same as the VERSION value for the package that was used to create this EXPLAIN table row.</p> <p>The value is blank for a statement in:</p> <ul style="list-style-type: none"> • A package for a basic trigger (TYPE='T') • A package for an application that was precompiled without SQL processing option VERSION • A package that was precompiled with an empty string for the VERSION value (TYPE=blank) <p>When the SQL statement is embedded in a compiled SQL function or native SQL procedure, this column indicates the version identifier of the function or procedure. When the SQL statement is embedded in an advanced trigger body, this column is not used and will be blank.</p>
EXPLAIN_TIME	TIMESTAMP NOT NULL	<p>The time when the EXPLAIN information was captured:</p> <p>All cached statements When the statement entered the cache, in the form of a full-precision timestamp value.</p> <p>Non-cached static statements When the statement was bound, in the form of a full precision timestamp value.</p> <p>Non-cached dynamic statements When EXPLAIN was executed, in the form of a value equivalent to a CHAR(16) representation of the time appended by 4 zeros.</p>
IXSCHEMA	VARCHAR(128) NOT NULL	The qualifier of the index.
IXNAME	VARCHAR(128) NOT NULL	The name of the index.
KEYSEQ	VARCHAR(128) NOT NULL	The numeric position of the key-target in the index.

Table 410. Descriptions of columns in DSN_KEYTGTDIST_TABLE (continued)

Column name	Data Type	Description
KEYVALUE	VARCHAR(2000) NOT NULL FOR BIT DATA	<p>Contains the data of a frequently occurring value. Statistics are not collected for an index on a ROWID column. If the value has a non-character data type, the data might not be printable.</p> <p>When the value of the TYPE column contains 'I', this column contains one of the following values:</p> <ul style="list-style-type: none"> • 'C9C4E7C6E4D3D2C6' for IDXFULKF • 'C9C4E7D3C5C1C6C6' for IDXLEAFF • 'C9C4E7D5D3E5D3C6' for IDXNLVLF
TYPE	CHAR(1) NOT NULL	<p>The type of statistics:</p> <p>C Cardinality</p> <p>F Frequent value</p> <p>H Histogram</p> <p>I Real-time index statistics</p>
CARDF	FLOAT NOT NULL	<p>For TYPE='C', the number of distinct values for the column group. For TYPE='H', the number of distinct values for the column group in a quantile indicated by the value of the QUANTILENO column.</p> <p>For TYPE='I', a value related to real-time index statistics values determined by the KEYVALUE column.</p>
KEYGROUPKEYNO	VARCHAR(254) NOT NULL FOR BIT DATA	<p>Contains a value that identifies the set of keys that are associated with the statistics. If the statistics are associated with more than a single key, it contains an array of SMALLINT key numbers with a dimension that is equal to the value in NUMKEYS. If the statistics are only associated with a single key, it contains 0.</p>
NUMKEYS	SMALLINT NOT NULL	<p>The number of keys that are associated with the statistics.</p>
FREQUENCYF	FLOAT NOT NULL	<p>The percentage of rows in the table with the value that is specified in the COLVALUE column when the number is multiplied by 100. For example, a value of '1' indicates 100%. A value of '.153' indicates 15.3%.</p>
QUANTILENO	SMALLINT NOT NULL	<p>The ordinary sequence number of a quantile in the whole consecutive value range, from low to high. This column is not updatable</p>

Table 410. Descriptions of columns in DSN_KEYTGTDIST_TABLE (continued)

Column name	Data Type	Description
LOWVALUE	VARCHAR(2000) NOT NULL FOR BIT DATA	For TYPE='H', this is the lower bound for the quantile indicated by the value of the QUANTILENO column. Not used if the value of the TYPE column is not 'H'. This column is not updatable.
HIGHVALUE	VARCHAR(2000) NOT NULL FOR BIT DATA	For TYPE='H', this is the higher bound for the quantile indicated by the value of the QUANTILENO column. This column is not used if the value of the TYPE column is not 'H'. This column is not updatable.
EXPANSION_REASON	CHAR(2) NOT NULL WITH DEFAULT	<p>This column applies only to statements that reference archive tables or temporal tables. For other statements, this column is blank.</p> <p>Indicates the effect of the CURRENT TEMPORAL BUSINESS_TIME special register, the CURRENT TEMPORAL SYSTEM_TIME special register, and the SYSIBMADM.GET_ARCHIVE built-in global variable. These items are controlled by the BUSTIMESENSITIVE, SYSTIMESENSITIVE, and ARCHIVESENSITIVE bind options.</p> <p>Db2 implicitly adds certain syntax to the query if one of the following conditions are true:</p> <ul style="list-style-type: none"> • The SYSIBMADM.GET_ARCHIVE global variable is set to Y and the ARCHIVESENSITIVE bind option is set to YES • The CURRENT TEMPORAL BUSINESS_TIME special register is not null and the BUSTIMESENSITIVE bind option is set to YES • The CURRENT TEMPORAL SYSTEM_TIME special register is not null and the SYSTIMESENSITIVE bind option is set to YES

Table 410. Descriptions of columns in DSN_KEYTGTDIST_TABLE (continued)

Column name	Data Type	Description
EXPANSION_REASON (continued)		<p>This column can have one of the following values:</p> <p>'A' The query contains implicit query transformation as a result of the SYSIBMADM.GET_ARCHIVE built-in global variable.</p> <p>'B' The query contains implicit query transformation as a result of the CURRENT TEMPORAL BUSINESS_TIME special register.</p> <p>'S' The query contains implicit query transformation as a result of the CURRENT TEMPORAL SYSTEM_TIME special register.</p> <p>'SB' The query contains implicit query transformation as a result of the CURRENT TEMPORAL SYSTEM_TIME special register and the CURRENT TEMPORAL BUSINESS_TIME special register.</p> <p>blank The query does not contain implicit query transformation.</p>
PER_STMT_ID	BIGINT NOT NULL	<p>The persistent statement identifier for SQL statements in Db2 catalog tables.</p> <p>For example, this column corresponds to the following catalog table columns that identify SQL statements:</p> <ul style="list-style-type: none"> • STMT_ID in SYSIBM.SYSPACKSTMT, for SQL statements in packages. • SDQ_STMT_ID in SYSIBM.SYSDYNQUERY, for stabilized dynamic SQL statements.
AP_PLANID	CHAR(16) FOR BIT DATA	A unique identifier for BIND or PREPARE optimizations for an SQL statement, in the form of an extended timestamp value.



Related concepts

[Dynamic collection of index filtering estimates \(Db2 Performance\)](#)

DSN_PGRANGE_TABLE

The page range table, DSN_PGRANGE_TABLE, contains information about qualified partitions for all page range scans in a query.

PSPI

Recommendation: Do not manually insert data into system-maintained EXPLAIN tables, and use care when deleting obsolete EXPLAIN table data. The data is intended to be manipulated only by the Db2 EXPLAIN function and optimization tools. Certain optimization tools depend on instances of the various EXPLAIN tables. Be careful not to delete data from or drop instances EXPLAIN tables that are created for these tools.

Qualifiers

Your subsystem or data sharing group can contain multiple instances of these tables that are qualified by user ID. These tables are populated with statement cost information when you issue the EXPLAIN statement or bind. They are also populated when you specify EXPLAIN(YES) or EXPLAIN(ONLY) in a BIND or REBIND command. SQL optimization tools might also create EXPLAIN tables that are qualified by a user ID. You can find the SQL statement for creating an instance of these tables in member DSNTESC of the SDSNSAMP library.

Sample CREATE TABLE statement

You can find a sample CREATE TABLE statement for each EXPLAIN table in member DSNTESC of the *prefix.SDSNSAMP* library. You can call the ADMIN_EXPLAIN_MAINT stored procedure to create EXPLAIN tables, upgrade them to the format for the current Db2 release, or complete other maintenance tasks. See [“ADMIN_EXPLAIN_MAINT stored procedure” on page 751](#) for information about using the *action* input parameter to request each of these tasks.

Column descriptions

The following table describes the columns of DSN_PGRANGE_TABLE.

Table 411. DSN_PGRANGE_TABLE description

Column name	Data type	Description
QUERYNO	INTEGER NOT NULL	<p>A number that identifies the statement that is being explained. The origin of the value depends on the context of the row:</p> <p>For rows produced by EXPLAIN statements The number specified in the QUERYNO clause, which is an optional part of the SELECT, INSERT, UPDATE, MERGE, and DELETE statement syntax.</p> <p>For rows not produced by EXPLAIN statements Db2 assigns a number that is based on the line number of the SQL statement in the source program.</p> <p>When the values of QUERYNO are based on the statement number in the source program, values that exceed 32767 are reported as 0. However, in certain rare cases, the value is not guaranteed to be unique.</p> <p>When the SQL statement is embedded in a compiled SQL function, native SQL procedure, or advanced trigger, if the QUERYNO clause is specified, its value is used by Db2. Otherwise Db2 assigns a number based on the line number of the SQL statement in the compiled SQL function, native SQL procedure, or advanced trigger.</p>

Table 411. DSN_PGRANGE_TABLE description (continued)

Column name	Data type	Description
QBLOCKNO	SMALLINT NOT NULL	A number that identifies each query block within a query. The value of the numbers are not in any particular order, nor are they necessarily consecutive.
TABNO	SMALLINT NOT NULL	The table number, a number which uniquely identifies the corresponding table reference within a query.
RANGE	SMALLINT NOT NULL	The sequence number of the current page range.
FIRSTPART	SMALLINT NOT NULL	The starting partition in the current page range.
LASTPART	SMALLINT NOT NULL	The ending partition in the current page range.
NUMPARTS	SMALLINT NOT NULL	The number of partitions in the current page range.
EXPLAIN_TIME	TIMESTAMP NOT NULL	The time when the EXPLAIN information was captured: All cached statements When the statement entered the cache, in the form of a full-precision timestamp value. Non-cached static statements When the statement was bound, in the form of a full precision timestamp value. Non-cached dynamic statements When EXPLAIN was executed, in the form of a value equivalent to a CHAR(16) representation of the time appended by 4 zeros.
GROUP_MEMBER	VARCHAR(24) NOT NULL	The member name of the Db2 that executed EXPLAIN. The column is blank if the Db2 subsystem was not in a data sharing environment when EXPLAIN was executed.
SECTNOI	INTEGER NOT NULL WITH DEFAULT	The section number of the statement. The value is taken from the same column in SYSPACKSTMT or SYSSTMT tables and can be used to join tables to reconstruct the access path for the statement. This column is applicable only for static statements. The default value of -1 indicates EXPLAIN information that was captured in DB2 9 or earlier.
APPLNAME	VARCHAR(24) NOT NULL WITH DEFAULT	The name of the application plan for the row. Applies only to embedded EXPLAIN statements that are executed from a plan or to statements that are explained when binding a plan. A blank indicates that the column is not applicable. When the SQL statement is embedded in a compiled SQL function, native SQL procedure, or advanced trigger, this column is not used, and is blank.

Table 411. DSN_PGRANGE_TABLE description (continued)

Column name	Data type	Description
PROGNAME	VARCHAR(128) NOT NULL WITH DEFAULT	<p>The name of the program or package containing the statement being explained. Applies only to embedded EXPLAIN statements and to statements explained as the result of binding a plan or package. A blank indicates that the column is not applicable.</p> <p>When the SQL statement is embedded in a compiled SQL function or native SQL procedure, this column indicates the specific name of the compiled SQL function or native SQL procedure. When the SQL statement is embedded in an advanced trigger, this column contains the name of the trigger.</p>
COLLID	VARCHAR(128) NOT NULL WITH DEFAULT	<p>The collection ID:</p> <p>'DSNEXPLAINMODEYES' The row originates from an application that specifies YES for the value of the CURRENT EXPLAIN MODE special register.</p> <p>'DSNEXPLAINMODEEXPLAIN' The row originates from an application that specifies EXPLAIN for the value of the CURRENT EXPLAIN MODE special register.</p> <p>When the SQL statement is embedded in a compiled SQL function, native SQL procedure, or advanced trigger, this column indicates the schema name of the compiled SQL function, native SQL procedure, or advanced trigger.</p>
VERSION	VARCHAR(122) NOT NULL WITH DEFAULT	<p>The version identifier for the package. Applies only to an embedded EXPLAIN statement executed from a package or to a statement that is explained when binding a package.</p> <p>If the value is not blank, the value is the same as the VERSION value for the package that was used to create this EXPLAIN table row.</p> <p>The value is blank for a statement in:</p> <ul style="list-style-type: none"> • A package for a basic trigger (TYPE='T') • A package for an application that was precompiled without SQL processing option VERSION • A package that was precompiled with an empty string for the VERSION value (TYPE=blank) <p>When the SQL statement is embedded in a compiled SQL function or native SQL procedure, this column indicates the version identifier of the function or procedure. When the SQL statement is embedded in an advanced trigger body, this column is not used and will be blank.</p>

Table 411. DSN_PGRANGE_TABLE description (continued)

Column name	Data type	Description
EXPANSION_REASON	CHAR(2) NOT NULL WITH DEFAULT	<p>This column applies only to statements that reference archive tables or temporal tables. For other statements, this column is blank.</p> <p>Indicates the effect of the CURRENT TEMPORAL BUSINESS_TIME special register, the CURRENT TEMPORAL SYSTEM_TIME special register, and the SYSIBMADM.GET_ARCHIVE built-in global variable. These items are controlled by the BUSTIMESENSITIVE, SYSTIMESENSITIVE, and ARCHIVESENSITIVE bind options.</p> <p>Db2 implicitly adds certain syntax to the query if one of the following conditions are true:</p> <ul style="list-style-type: none"> • The SYSIBMADM.GET_ARCHIVE global variable is set to Y and the ARCHIVESENSITIVE bind option is set to YES • The CURRENT TEMPORAL BUSINESS_TIME special register is not null and the BUSTIMESENSITIVE bind option is set to YES • The CURRENT TEMPORAL SYSTEM_TIME special register is not null and the SYSTIMESENSITIVE bind option is set to YES <p>This column can have one of the following values:</p> <p>'A' The query contains implicit query transformation as a result of the SYSIBMADM.GET_ARCHIVE built-in global variable.</p> <p>'B' The query contains implicit query transformation as a result of the CURRENT TEMPORAL BUSINESS_TIME special register.</p> <p>'S' The query contains implicit query transformation as a result of the CURRENT TEMPORAL SYSTEM_TIME special register.</p> <p>'SB' The query contains implicit query transformation as a result of the CURRENT TEMPORAL SYSTEM_TIME special register and the CURRENT TEMPORAL BUSINESS_TIME special register.</p> <p>blank The query does not contain implicit query transformation.</p>
PER_STMT_ID	BIGINT NOT NULL	<p>The persistent statement identifier for SQL statements in Db2 catalog tables.</p> <p>For example, this column corresponds to the following catalog table columns that identify SQL statements:</p> <ul style="list-style-type: none"> • STMT_ID in SYSIBM.SYSPACKSTMT, for SQL statements in packages. • SDQ_STMT_ID in SYSIBM.SYSDYNQUERY, for stabilized dynamic SQL statements.

Table 411. DSN_PGRANGE_TABLE description (continued)

Column name	Data type	Description
AP_PLANID	CHAR(16) FOR BIT DATA	A unique identifier for BIND or PREPARE optimizations for an SQL statement, in the form of an extended timestamp value.

PSPI

DSN_PGROUP_TABLE

The parallel group table, DSN_PGROUP_TABLE, contains information about the parallel groups in a query.

PSPI

Recommendation: Do not manually insert data into system-maintained EXPLAIN tables, and use care when deleting obsolete EXPLAIN table data. The data is intended to be manipulated only by the Db2 EXPLAIN function and optimization tools. Certain optimization tools depend on instances of the various EXPLAIN tables. Be careful not to delete data from or drop instances EXPLAIN tables that are created for these tools.

Qualifiers

Your subsystem or data sharing group can contain multiple instances of these tables that are qualified by user ID. These tables are populated with statement cost information when you issue the EXPLAIN statement or bind. They are also populated when you specify EXPLAIN(YES) or EXPLAIN(ONLY) in a BIND or REBIND command. SQL optimization tools might also create EXPLAIN tables that are qualified by a user ID. You can find the SQL statement for creating an instance of these tables in member DSNTESC of the SDSNSAMP library.

Sample CREATE TABLE statement

You can find a sample CREATE TABLE statement for each EXPLAIN table in member DSNTESC of the *prefix.SDSNSAMP* library. You can call the ADMIN_EXPLAIN_MAINT stored procedure to create EXPLAIN tables, upgrade them to the format for the current Db2 release, or complete other maintenance tasks. See [“ADMIN_EXPLAIN_MAINT stored procedure” on page 751](#) for information about using the *action* input parameter to request each of these tasks.

Column descriptions

The following table describes the columns of DSN_PGROUP_TABLE

Table 412. DSN_PGROUPTABLE description

Column name	Data type	Description
QUERYNO	INTEGER NOT NULL	<p>A number that identifies the statement that is being explained. The origin of the value depends on the context of the row:</p> <p>For rows produced by EXPLAIN statements The number specified in the QUERYNO clause, which is an optional part of the SELECT, INSERT, UPDATE, MERGE, and DELETE statement syntax.</p> <p>For rows not produced by EXPLAIN statements Db2 assigns a number that is based on the line number of the SQL statement in the source program.</p> <p>When the values of QUERYNO are based on the statement number in the source program, values that exceed 32767 are reported as 0. However, in certain rare cases, the value is not guaranteed to be unique.</p> <p>When the SQL statement is embedded in a compiled SQL function, native SQL procedure, or advanced trigger, if the QUERYNO clause is specified, its value is used by Db2. Otherwise Db2 assigns a number based on the line number of the SQL statement in the compiled SQL function, native SQL procedure, or advanced trigger.</p>
QBLOCKNO	SMALLINT NOT NULL	A number that identifies each query block within a query. The value of the numbers are not in any particular order, nor are they necessarily consecutive.
PLANNAME	VARCHAR(24) NOT NULL	The application plan name.
COLLID	VARCHAR(128) NOT NULL	<p>The collection ID:</p> <p>'DSNEXPLAINMODEYES' The row originates from an application that specifies YES for the value of the CURRENT EXPLAIN MODE special register.</p> <p>'DSNEXPLAINMODEEXPLAIN' The row originates from an application that specifies EXPLAIN for the value of the CURRENT EXPLAIN MODE special register.</p> <p>When the SQL statement is embedded in a compiled SQL function, native SQL procedure, or advanced trigger, this column indicates the schema name of the compiled SQL function, native SQL procedure, or advanced trigger.</p>

Table 412. DSN_PGROUPTABLE description (continued)

Column name	Data type	Description
PROGNAME	VARCHAR(128) NOT NULL	<p>The name of the program or package containing the statement being explained. Applies only to embedded EXPLAIN statements and to statements explained as the result of binding a plan or package. A blank indicates that the column is not applicable.</p> <p>When the SQL statement is embedded in a compiled SQL function or native SQL procedure, this column indicates the specific name of the compiled SQL function or native SQL procedure. When the SQL statement is embedded in an advanced trigger, this column contains the name of the trigger.</p>
EXPLAIN_TIME	TIMESTAMP NOT NULL	<p>The time when the EXPLAIN information was captured:</p> <p>All cached statements When the statement entered the cache, in the form of a full-precision timestamp value.</p> <p>Non-cached static statements When the statement was bound, in the form of a full precision timestamp value.</p> <p>Non-cached dynamic statements When EXPLAIN was executed, in the form of a value equivalent to a CHAR(16) representation of the time appended by 4 zeros.</p>
VERSION	VARCHAR(122) NOT NULL	<p>The version identifier for the package. Applies only to an embedded EXPLAIN statement executed from a package or to a statement that is explained when binding a package.</p> <p>If the value is not blank, the value is the same as the VERSION value for the package that was used to create this EXPLAIN table row.</p> <p>The value is blank for a statement in:</p> <ul style="list-style-type: none"> • A package for a basic trigger (TYPE='T') • A package for an application that was precompiled without SQL processing option VERSION • A package that was precompiled with an empty string for the VERSION value (TYPE=blank) <p>When the SQL statement is embedded in a compiled SQL function or native SQL procedure, this column indicates the version identifier of the function or procedure. When the SQL statement is embedded in an advanced trigger body, this column is not used and will be blank.</p>
GROUPID	SMALLINT NOT NULL	The parallel group identifier within the current query block.
FIRSTPLAN	SMALLINT NOT NULL	The plan number of the first contributing mini-plan associated within this parallel group.
LASTPLAN	SMALLINT NOT NULL	The plan number of the last mini-plan associated within this parallel group.

Table 412. DSN_PGROUPE_TABLE description (continued)

Column name	Data type	Description
CPUCOST	REAL NOT NULL	The estimated total CPU cost of this parallel group in milliseconds.
IO COST	REAL NOT NULL	The estimated total I/O cost of this parallel group in milliseconds.
BESTTIME	REAL NOT NULL	The estimated elapsed time for each parallel task for this parallel group.
DEGREE	SMALLINT NOT NULL	The degree of parallelism for this parallel group determined at bind time. Max parallelism degree if the Table space is large is 255, otherwise 64.
MODE	CHAR(1) NOT NULL	The parallel mode: 'I' I/O parallelism 'C' CPU parallelism 'N' No parallelism
REASON	SMALLINT NOT NULL	The reason code for downgrading parallelism mode.
LOCALCPU	SMALLINT NOT NULL	The number of CPUs currently online when preparing the query.
TOTALCPU	SMALLINT NOT NULL	The total number of CPUs in sysplex. LOCALCPU and TOTALCPU are different only for the Db2 coordinator in a sysplex.
FIRSTBASE	SMALLINT	The table number of the table that partitioning is performed on.
LARGETS	CHAR(1)	'Y' if the TableSpace is large in this group.
PARTKIND	CHAR(1)	The partitioning type: 'L' Logical partitioning 'P' Physical partitioning
GROUPTYPE	CHAR(3)	Determines what operations this parallel group contains: table Access, Join, or Sort 'A' 'AJ' 'AJS'
ORDER	CHAR(1)	The ordering requirement of this parallel group : 'N' No order. Results need no ordering. 'T' Natural Order. Ordering is required but results already ordered if accessed via index. 'K' Key Order. Ordering achieved by sort. Results ordered by sort key. This value applies only to parallel sort.

Table 412. DSN_PGROUP_TABLE description (continued)

Column name	Data type	Description
STYLE	CHAR(4)	The Input/Output format style of this parallel group. Blank for IO Parallelism. For other modes: 'RIRO' Records IN, Records OUT 'WIRO' Work file IN, Records OUT 'WIWO' Work file IN, Work file OUT
RANGEKIND	CHAR(1)	The range type: 'K' Key range 'L' IN-list elements partitioning 'P' Page range 'R' Record range partitioning
NKEYCOLS	SMALLINT	The number of interesting key columns, that is, the number of columns that will participate in the key operation for this parallel group.
LOWBOUND	VARCHAR(40) FOR BIT DATA	The low bound of parallel group.
HIGHBOUND	VARCHAR(40) FOR BIT DATA	The high bound of parallel group.
LOWKEY	VARCHAR(40) FOR BIT DATA	The low key of range if partitioned by key range.
HIGHKEY	VARCHAR(40) FOR BIT DATA	The high key of range if partitioned by key range.
FIRSTPAGE	CHAR(4) FOR BIT DATA	The first page in range if partitioned by page range.
LASTPAGE	CHAR(4) FOR BIT DATA	The last page in range if partitioned by page range.
GROUP_MEMBER	VARCHAR(24) NOT NULL	The member name of the Db2 that executed EXPLAIN. The column is blank if the Db2 subsystem was not in a data sharing environment when EXPLAIN was executed.
HOST_REASON	SMALLINT	IBM internal use only.
PARA_TYPE	CHAR(4)	IBM internal use only.
PART_INNER	CHAR(1)	IBM internal use only.
GRNU_KEYRNG	CHAR(1)	IBM internal use only.
OPEN_KEYRNG	CHAR(1)	IBM internal use only.

Table 412. DSN_PGROUPTABLE description (continued)

Column name	Data type	Description
APPLNAME	VARCHAR(24) NOT NULL WITH DEFAULT	<p>The name of the application plan for the row. Applies only to embedded EXPLAIN statements that are executed from a plan or to statements that are explained when binding a plan. A blank indicates that the column is not applicable.</p> <p>When the SQL statement is embedded in a compiled SQL function, native SQL procedure, or advanced trigger, this column is not used, and is blank.</p>
SECTNOI	INTEGER NOT NULL WITH DEFAULT	<p>The section number of the statement. The value is taken from the same column in SYSPACKSTMT or SYSSTMT tables and can be used to join tables to reconstruct the access path for the statement. This column is applicable only for static statements. The default value of -1 indicates EXPLAIN information that was captured in DB2 9 or earlier.</p>
STRAW_MODEL	CHAR(1) NOT NULL WITH DEFAULT	IBM internal use only.

Table 412. DSN_PGROUUP_TABLE description (continued)

Column name	Data type	Description
EXPANSION_REASON	CHAR(2) NOT NULL WITH DEFAULT	<p>This column applies only to statements that reference archive tables or temporal tables. For other statements, this column is blank.</p> <p>Indicates the effect of the CURRENT TEMPORAL BUSINESS_TIME special register, the CURRENT TEMPORAL SYSTEM_TIME special register, and the SYSIBMADM.GET_ARCHIVE built-in global variable. These items are controlled by the BUSTIMESENSITIVE, SYSTIMESENSITIVE, and ARCHIVESENSITIVE bind options.</p> <p>Db2 implicitly adds certain syntax to the query if one of the following conditions are true:</p> <ul style="list-style-type: none"> • The SYSIBMADM.GET_ARCHIVE global variable is set to Y and the ARCHIVESENSITIVE bind option is set to YES • The CURRENT TEMPORAL BUSINESS_TIME special register is not null and the BUSTIMESENSITIVE bind option is set to YES • The CURRENT TEMPORAL SYSTEM_TIME special register is not null and the SYSTIMESENSITIVE bind option is set to YES <p>This column can have one of the following values:</p> <p>'A' The query contains implicit query transformation as a result of the SYSIBMADM.GET_ARCHIVE built-in global variable.</p> <p>'B' The query contains implicit query transformation as a result of the CURRENT TEMPORAL BUSINESS_TIME special register.</p> <p>'S' The query contains implicit query transformation as a result of the CURRENT TEMPORAL SYSTEM_TIME special register.</p> <p>'SB' The query contains implicit query transformation as a result of the CURRENT TEMPORAL SYSTEM_TIME special register and the CURRENT TEMPORAL BUSINESS_TIME special register.</p> <p>blank The query does not contain implicit query transformation.</p>
PER_STMT_ID	BIGINT NOT NULL	<p>The persistent statement identifier for SQL statements in Db2 catalog tables.</p> <p>For example, this column corresponds to the following catalog table columns that identify SQL statements:</p> <ul style="list-style-type: none"> • STMT_ID in SYSIBM.SYSPACKSTMT, for SQL statements in packages. • SDQ_STMT_ID in SYSIBM.SYSDYNQUERY, for stabilized dynamic SQL statements.

Table 412. DSN_PGROU_P_TABLE description (continued)

Column name	Data type	Description
AP_PLANID	CHAR(16) FOR BIT DATA	A unique identifier for BIND or PREPARE optimizations for an SQL statement, in the form of an extended timestamp value.

PSPI

DSN_PREDICAT_TABLE

The predicate table, DSN_PREDICAT_TABLE, contains information about all of the predicates in a query. It is also used as input when you issue a BIND QUERY command to override predicate selectivities for matching SQL statements.

PSPI

Recommendation: Do not manually insert data into system-maintained EXPLAIN tables, and use care when deleting obsolete EXPLAIN table data. The data is intended to be manipulated only by the Db2 EXPLAIN function and optimization tools. Certain optimization tools depend on instances of the various EXPLAIN tables. Be careful not to delete data from or drop instances EXPLAIN tables that are created for these tools.

Qualifiers

Your subsystem or data sharing group can contain multiple instances of these tables that are qualified by user ID. These tables are populated with statement cost information when you issue the EXPLAIN statement or bind. They are also populated when you specify EXPLAIN(YES) or EXPLAIN(ONLY) in a BIND or REBIND command. SQL optimization tools might also create EXPLAIN tables that are qualified by a user ID. You can find the SQL statement for creating an instance of these tables in member DSNTESC of the SDSNSAMP library.

Sample CREATE TABLE statement

You can find a sample CREATE TABLE statement for each EXPLAIN table in member DSNTESC of the *prefix.SDSNSAMP* library. You can call the ADMIN_EXPLAIN_MAINT stored procedure to create EXPLAIN tables, upgrade them to the format for the current Db2 release, or complete other maintenance tasks. See [“ADMIN_EXPLAIN_MAINT stored procedure” on page 751](#) for information about using the *action* input parameter to request each of these tasks.

Column descriptions

The following table describes the columns of the DSN_PREDICAT_TABLE

Table 413. DSN_PREDICAT_TABLE description

Column name	Data type	Description
QUERYNO	INTEGER NOT NULL	<p>A number that identifies the statement that is being explained. The origin of the value depends on the context of the row:</p> <p>For rows produced by EXPLAIN statements The number specified in the QUERYNO clause, which is an optional part of the SELECT, INSERT, UPDATE, MERGE, and DELETE statement syntax.</p> <p>For rows not produced by EXPLAIN statements Db2 assigns a number that is based on the line number of the SQL statement in the source program.</p> <p>When the values of QUERYNO are based on the statement number in the source program, values that exceed 32767 are reported as 0. However, in certain rare cases, the value is not guaranteed to be unique.</p> <p>When the SQL statement is embedded in a compiled SQL function, native SQL procedure, or advanced trigger, if the QUERYNO clause is specified, its value is used by Db2. Otherwise Db2 assigns a number based on the line number of the SQL statement in the compiled SQL function, native SQL procedure, or advanced trigger.</p>
QBLOCKNO	SMALLINT NOT NULL	<p>A number that identifies each query block within a query. The value of the numbers are not in any particular order, nor are they necessarily consecutive.</p>
APPLNAME	VARCHAR(24) NOT NULL	<p>The name of the application plan for the row. Applies only to embedded EXPLAIN statements that are executed from a plan or to statements that are explained when binding a plan. A blank indicates that the column is not applicable.</p> <p>When the SQL statement is embedded in a compiled SQL function, native SQL procedure, or advanced trigger, this column is not used, and is blank.</p>
PROGNAME	VARCHAR(128) NOT NULL	<p>The name of the program or package containing the statement being explained. Applies only to embedded EXPLAIN statements and to statements explained as the result of binding a plan or package. A blank indicates that the column is not applicable.</p> <p>When the SQL statement is embedded in a compiled SQL function or native SQL procedure, this column indicates the specific name of the compiled SQL function or native SQL procedure. When the SQL statement is embedded in an advanced trigger, this column contains the name of the trigger.</p>
PREDNO	INTEGER NOT NULL	<p>The predicate number, a number used to identify a predicate within a query.</p>

Table 413. DSN_PREDICAT_TABLE description (continued)

Column name	Data type	Description
TYPE	CHAR(8) NOT NULL	<p>A string used to indicate the type or the operation of the predicate. The possible values are:</p> <ul style="list-style-type: none"> • 'AND' • 'BETWEEN' • 'EQUAL' • 'EXISTS' • 'COMPOUND' • 'HAVING' • 'IN' • 'LIKE' • 'NOT LIKE' • 'NOTEXIST' • 'OTHERS' • 'OR' • 'RANGE' • 'SUBQUERY' • 'XEXISTS' • 'NXEXISTS'
LEFT_HAND_SIDE	VARCHAR(128) NOT NULL	<p>Describes the left side of the predicate.</p> <p>If the left side of the predicate is a table column, this value indicates the name of that column.</p> <p>Other possible values are:</p> <ul style="list-style-type: none"> • 'VALUE' • 'COLEXP' • 'NONCOLEXP' • 'CORSUB' • 'NONCORSUB' • 'SUBQUERY' • 'EXPRESSION' • Blanks
LEFT_HAND_PNO	INTEGER NOT NULL	<p>If the predicate is a compound predicate (AND/OR), then this column indicates the first child predicate. However, this column is not reliable when the predicate tree consolidation happens. Use PARENT_PNO instead to reconstruct the predicate tree.</p>
LHS_TABNO	SMALLINT NOT NULL	<p>If the left side of the predicate is a table column or a column expression in an expression-based index, then this column indicates a number which uniquely identifies the corresponding table reference within a query.</p>
LHS_QBNO	SMALLINT NOT NULL	<p>If the left side of the predicate is a table column or a column expression in expression-based index, then this column indicates a number which uniquely identifies the corresponding query block within a query.</p>

Table 413. DSN_PREDICAT_TABLE description (continued)

Column name	Data type	Description
RIGHT_HAND_SIDE	VARCHAR(128) NOT NULL	<p>Describes the right side of the predicate.</p> <p>If the right side of the predicate is a table column, this value column indicates the column name.</p> <p>Other possible values are:</p> <ul style="list-style-type: none"> • 'VALUE' • 'COLEXP' • 'NONCOLEXP' • 'CORSUB' • 'NONCORSUB' • 'SUBQUERY' • 'EXPRESSION' • Blanks
RIGHT_HAND_PNO	INTEGER NOT NULL	If the predicate is a compound predicate (AND/OR), then this column indicates the second child predicate. However, this column is not reliable when the predicate tree consolidation happens. Use PARENT_PNO instead to reconstruct the predicate tree.
RHS_TABNO	CHAR(1) NOT NULL	If the right side of the predicate is a table column or a column expression in an index on expression, then this column indicates a number which uniquely identifies the corresponding table reference within a query.
RHS_QBNO	CHAR(1) NOT NULL	If the right side of the predicate is a subquery or a column expression in an expression-based index, then this column indicates a number which uniquely identifies the corresponding query block within a query.
FILTER_FACTOR	FLOAT NOT NULL	The estimated filter factor.
BOOLEAN_TERM	CHAR(1) NOT NULL	Whether this predicate can be used to determine the truth value of the whole WHERE clause.
SEARCHARG	CHAR(1) NOT NULL	Whether this predicate can be processed by data manager (DM). If it is not, then the relational data service (RDS) needs to be used to take care of it, which is more costly.
JOIN	CHAR(1) NOT NULL	Whether the predicate can be used as a simple join predicate between two tables.
AFTER_JOIN	CHAR(1) NOT NULL	<p>Indicates the predicate evaluation phase:</p> <p>'A' After join</p> <p>'D' During join</p> <p>blank Not applicable</p>

Table 413. DSN_PREDICAT_TABLE description (continued)

Column name	Data type	Description
ADDED_PRED	CHAR(1) NOT NULL	<p>Whether the predicate is generated by Db2, and the reason why the predicate is added:</p> <p>blank Db2 did not add the predicate.</p> <p>'B' For bubble up.</p> <p>'C' For correlation.</p> <p>'J' For join.</p> <p>'K' For LIKE for expression-based index.</p> <p>'L' For localization.</p> <p>'P' For push down.</p> <p>'R' For page range.</p> <p>'S' For simplification.</p> <p>'T' For transitive closure.</p>
REDUNDANT_PRED	CHAR(1) NOT NULL	Whether it is a redundant predicate, which means evaluation of other predicates in the query already determines the result that the predicate provides.
DIRECT_ACCESS	CHAR(1) NOT NULL	Whether the predicate is direct access, which means one can navigate directly to the row through ROWID.
KEYFIELD	CHAR(1) NOT NULL	Whether the predicate includes the index key column of the involved table for all applicable indexes considered by Db2.
EXPLAIN_TIME	TIMESTAMP NOT NULL	<p>The time when the EXPLAIN information was captured:</p> <p>All cached statements When the statement entered the cache, in the form of a full-precision timestamp value.</p> <p>Non-cached static statements When the statement was bound, in the form of a full precision timestamp value.</p> <p>Non-cached dynamic statements When EXPLAIN was executed, in the form of a value equivalent to a CHAR(16) representation of the time appended by 4 zeros.</p>
CATEGORY	SMALLINT NOT NULL	IBM internal use only.
CATEGORY_B	SMALLINT NOT NULL	IBM internal use only.

Table 413. DSN_PREDICAT_TABLE description (continued)

Column name	Data type	Description
TEXT	VARCHAR(2000) NOT NULL	The text of the transformed predicate text. If the text of the predicate contains more than 2000 characters, it is truncated.
PRED_ENCODE	CHAR(1) NOT NULL WITH DEFAULT	IBM internal use only.
PRED_CCSID	SMALLINT NOT NULL WITH DEFAULT	IBM internal use only.
PRED_MCCSID	SMALLINT NOT NULL WITH DEFAULT	IBM internal use only.
MARKER	CHAR(1) NOT NULL WITH DEFAULT	Whether this predicate includes host variables, parameter markers, or special registers.
PARENT_PNO	INTEGER NOT NULL	The parent predicate number. If this predicate is a root predicate within a query block, then this column is 0.
NEGATION	CHAR(1) NOT NULL	Whether this predicate is negated via NOT.
LITERALS	VARCHAR(128) NOT NULL	This column indicates the literal value or literal values separated by colon symbols.
CLAUSE	CHAR(8) NOT NULL	The clause where the predicate exists: 'HAVING ' The HAVING clause 'ON ' The ON clause 'WHERE ' The WHERE clause SELECT The SELECT clause
GROUP_MEMBER	VARCHAR(24) NOT NULL	The member name of the Db2 that executed EXPLAIN. The column is blank if the Db2 subsystem was not in a data sharing environment when EXPLAIN was executed.
ORIGIN	CHAR(1) NOT NULL WITH DEFAULT	Indicates the origin of the predicate. Blank Generated by Db2 C Column mask R Row permission U Specified by the user
UNCERTAINTY	FLOAT(4) NOT NULL WITH DEFAULT	Describes the uncertainty factor of a predicate's estimated filter factor. A bigger value indicates a higher degree of uncertainty. Value zero indicates no uncertainty or uncertainty not considered.

Table 413. DSN_PREDICAT_TABLE description (continued)

Column name	Data type	Description
SECTNOI	INTEGER NOT NULL WITH DEFAULT	The section number of the statement. The value is taken from the same column in SYSPACKSTMT or SYSSTMT tables and can be used to join tables to reconstruct the access path for the statement. This column is applicable only for static statements. The default value of -1 indicates EXPLAIN information that was captured in DB2 9 or earlier.
COLLID	VARCHAR(128) NOT NULL WITH DEFAULT	<p>The collection ID:</p> <p>'DSNEXPLAINMODEYES' The row originates from an application that specifies YES for the value of the CURRENT EXPLAIN MODE special register.</p> <p>'DSNEXPLAINMODEEXPLAIN' The row originates from an application that specifies EXPLAIN for the value of the CURRENT EXPLAIN MODE special register.</p> <p>When the SQL statement is embedded in a compiled SQL function, native SQL procedure, or advanced trigger, this column indicates the schema name of the compiled SQL function, native SQL procedure, or advanced trigger.</p>
VERSION	VARCHAR(122) NOT NULL WITH DEFAULT	<p>The version identifier for the package. Applies only to an embedded EXPLAIN statement executed from a package or to a statement that is explained when binding a package.</p> <p>If the value is not blank, the value is the same as the VERSION value for the package that was used to create this EXPLAIN table row.</p> <p>The value is blank for a statement in:</p> <ul style="list-style-type: none"> • A package for a basic trigger (TYPE='T') • A package for an application that was precompiled without SQL processing option VERSION • A package that was precompiled with an empty string for the VERSION value (TYPE=blank) <p>When the SQL statement is embedded in a compiled SQL function or native SQL procedure, this column indicates the version identifier of the function or procedure. When the SQL statement is embedded in an advanced trigger body, this column is not used and will be blank.</p>

Table 413. DSN_PREDICAT_TABLE description (continued)

Column name	Data type	Description
EXPANSION_REASON	CHAR(2) NOT NULL WITH DEFAULT	<p>This column applies only to statements that reference archive tables or temporal tables. For other statements, this column is blank.</p> <p>Indicates the effect of the CURRENT TEMPORAL BUSINESS_TIME special register, the CURRENT TEMPORAL SYSTEM_TIME special register, and the SYSIBMADM.GET_ARCHIVE built-in global variable. These items are controlled by the BUSTIMESENSITIVE, SYSTIMESENSITIVE, and ARCHIVESENSITIVE bind options.</p> <p>Db2 implicitly adds certain syntax to the query if one of the following conditions are true:</p> <ul style="list-style-type: none"> • The SYSIBMADM.GET_ARCHIVE global variable is set to Y and the ARCHIVESENSITIVE bind option is set to YES • The CURRENT TEMPORAL BUSINESS_TIME special register is not null and the BUSTIMESENSITIVE bind option is set to YES • The CURRENT TEMPORAL SYSTEM_TIME special register is not null and the SYSTIMESENSITIVE bind option is set to YES <p>This column can have one of the following values:</p> <p>'A' The query contains implicit query transformation as a result of the SYSIBMADM.GET_ARCHIVE built-in global variable.</p> <p>'B' The query contains implicit query transformation as a result of the CURRENT TEMPORAL BUSINESS_TIME special register.</p> <p>'S' The query contains implicit query transformation as a result of the CURRENT TEMPORAL SYSTEM_TIME special register.</p> <p>'SB' The query contains implicit query transformation as a result of the CURRENT TEMPORAL SYSTEM_TIME special register and the CURRENT TEMPORAL BUSINESS_TIME special register.</p> <p>blank The query does not contain implicit query transformation.</p>
PER_STMT_ID	BIGINT NOT NULL	<p>The persistent statement identifier for SQL statements in Db2 catalog tables.</p> <p>For example, this column corresponds to the following catalog table columns that identify SQL statements:</p> <ul style="list-style-type: none"> • STMT_ID in SYSIBM.SYSPACKSTMT, for SQL statements in packages. • SDQ_STMT_ID in SYSIBM.SYSDYNQUERY, for stabilized dynamic SQL statements.
AP_PLANID	CHAR(16) FOR BIT DATA	A unique identifier for BIND or PREPARE optimizations for an SQL statement, in the form of an extended timestamp value.

PSPI

Related concepts

[Predicates](#)

A *predicate* specifies a condition that is true, false, or unknown about a given value, row, or group.

[Predicates and access path selection \(Db2 Performance\)](#)

Related tasks

[Overriding predicate selectivities at the statement level \(Db2 Performance\)](#)

Related reference

[Tables for influencing access path selection \(Db2 Performance\)](#)

[BIND QUERY subcommand \(DSN\) \(Db2 Commands\)](#)

DSN_PREDICATE_SELECTIVITY table

The predicate selectivity table contains information about the selectivity of predicates that are used for access path selection. It is used as an input table for the BIND QUERY command when selectivity overrides are specified.

PSPI

When selectivity overrides are not specified, or specified selectivity overrides cannot be used by Db2, the DSN_PREDICATE_SELECTIVITY table contains one row for each predicate in DSN_PREDICAT_TABLE that is used for access path selection. These rows contain ASSUMPTION='NORMAL' values.

DSN_PREDICATE_SELECTIVITY does not contain rows from DSN_PREDICAT_TABLE for predicates that are not used for access path selection.

When selectivity overrides are specified and used by Db2, this table also contains one row for each selectivity override that was used. These rows contain ASSUMPTION='OVERRIDE' values.

Additionally, if the sum of the weights for all specified selectivity override instances is less than one, this table contains one row for each predicate in DSN_PREDICAT_TABLE that is used for access path selection. These rows contain ASSUMPTION='NORMAL' values and WEIGHT values equal to one minus the sum of the specified override weight values.

Recommendation: Do not manually insert data into system-maintained EXPLAIN tables, and use care when deleting obsolete EXPLAIN table data. The data is intended to be manipulated only by the Db2 EXPLAIN function and optimization tools. Certain optimization tools depend on instances of the various EXPLAIN tables. Be careful not to delete data from or drop instances EXPLAIN tables that are created for these tools.

Qualifiers

Your subsystem or data sharing group can contain multiple instances of these tables that are qualified by user ID. These tables are populated with statement cost information when you issue the EXPLAIN statement or bind. They are also populated when you specify EXPLAIN(YES) or EXPLAIN(ONLY) in a BIND or REBIND command. SQL optimization tools might also create EXPLAIN tables that are qualified by a user ID. You can find the SQL statement for creating an instance of these tables in member DSNTESC of the SDSNSAMP library.

Sample CREATE TABLE statement

You can find a sample CREATE TABLE statement for each EXPLAIN table in member DSNTESC of the *prefix*.SDSNSAMP library. You can call the ADMIN_EXPLAIN_MAINT stored procedure to create EXPLAIN tables, upgrade them to the format for the current Db2 release, or complete other maintenance tasks. See [“ADMIN_EXPLAIN_MAINT stored procedure” on page 751](#) for information about using the *action* input parameter to request each of these tasks.

Column descriptions

Your subsystem or data sharing group can contain more than one of these tables, including a table with the qualifier SYSIBM, a table with the qualifier DB2OSCA, and additional tables that are qualified by user IDs.

The following table shows the descriptions of the columns in the DSN_PREDICATE_SELECTIVITY table.

Table 414. Descriptions of columns in the DSN_PREDICATE_SELECTIVITY table

Column name	Data Type	Description
QUERYNO	INTEGER NOT NULL	<p>A number that identifies the statement that is being explained. The origin of the value depends on the context of the row:</p> <p>For rows produced by EXPLAIN statements The number specified in the QUERYNO clause, which is an optional part of the SELECT, INSERT, UPDATE, MERGE, and DELETE statement syntax.</p> <p>For rows not produced by EXPLAIN statements Db2 assigns a number that is based on the line number of the SQL statement in the source program.</p> <p>When the values of QUERYNO are based on the statement number in the source program, values that exceed 32767 are reported as 0. However, in certain rare cases, the value is not guaranteed to be unique.</p> <p>When the SQL statement is embedded in a compiled SQL function, native SQL procedure, or advanced trigger, if the QUERYNO clause is specified, its value is used by Db2. Otherwise Db2 assigns a number based on the line number of the SQL statement in the compiled SQL function, native SQL procedure, or advanced trigger.</p>
QBLOCKNO	SMALLINT NOT NULL	<p>A number that identifies each query block within a query. The value of the numbers are not in any particular order, nor are they necessarily consecutive.</p>
APPLNAME	VARCHAR(24) NOT NULL	<p>The name of the application plan for the row. Applies only to embedded EXPLAIN statements that are executed from a plan or to statements that are explained when binding a plan. A blank indicates that the column is not applicable.</p> <p>When the SQL statement is embedded in a compiled SQL function, native SQL procedure, or advanced trigger, this column is not used, and is blank.</p>

Table 414. Descriptions of columns in the DSN_PREDICATE_SELECTIVITY table (continued)

Column name	Data Type	Description
PROGNAME	VARCHAR(128) NOT NULL	<p>The name of the program or package containing the statement being explained. Applies only to embedded EXPLAIN statements and to statements explained as the result of binding a plan or package. A blank indicates that the column is not applicable.</p> <p>When the SQL statement is embedded in a compiled SQL function or native SQL procedure, this column indicates the specific name of the compiled SQL function or native SQL procedure. When the SQL statement is embedded in an advanced trigger, this column contains the name of the trigger.</p>
SECTNOI	INTEGER NOT NULL WITH DEFAULT	<p>The section number of the statement. The value is taken from the same column in SYSPACKSTMT or SYSSTMT tables and can be used to join tables to reconstruct the access path for the statement. This column is applicable only for static statements. The default value of -1 indicates EXPLAIN information that was captured in DB2 9 or earlier.</p>
COLLID	VARCHAR(128) NOT NULL	<p>The collection ID:</p> <p>'DSNEXPLAINMODEYES' The row originates from an application that specifies YES for the value of the CURRENT EXPLAIN MODE special register.</p> <p>'DSNEXPLAINMODEEXPLAIN' The row originates from an application that specifies EXPLAIN for the value of the CURRENT EXPLAIN MODE special register.</p> <p>When the SQL statement is embedded in a compiled SQL function, native SQL procedure, or advanced trigger, this column indicates the schema name of the compiled SQL function, native SQL procedure, or advanced trigger.</p>

Table 414. Descriptions of columns in the DSN_PREDICATE_SELECTIVITY table (continued)

Column name	Data Type	Description
VERSION	VARCHAR(122) NOT NULL	<p>The version identifier for the package. Applies only to an embedded EXPLAIN statement executed from a package or to a statement that is explained when binding a package.</p> <p>If the value is not blank, the value is the same as the VERSION value for the package that was used to create this EXPLAIN table row.</p> <p>The value is blank for a statement in:</p> <ul style="list-style-type: none"> • A package for a basic trigger (TYPE='T') • A package for an application that was precompiled without SQL processing option VERSION • A package that was precompiled with an empty string for the VERSION value (TYPE=blank) <p>When the SQL statement is embedded in a compiled SQL function or native SQL procedure, this column indicates the version identifier of the function or procedure. When the SQL statement is embedded in an advanced trigger body, this column is not used and will be blank.</p>
PREDNO	INTEGER NOT NULL	The predicate number, a number used to identify a specific predicate within a query.
INSTANCE	SMALLINT NOT NULL	The selectivity instance. Used to group related selectivities.
SELECTIVITY	FLOAT NOT NULL	The selectivity estimate.
WEIGHT	FLOAT(4) NOT NULL	The percentage of executions that have the specified selectivity. For example, a value of 0.25 means that 25% of the time when query is executed it has this selectivity.
ASSUMPTION	VARCHAR(128) NOT NULL	<p>Indicates how the selectivity was estimated, or is used. One of the following values:</p> <p>'NORMAL' Selectivity is estimated by using the normal selectivity assumptions.</p> <p>'OVERRIDE' Selectivity is based on an override.</p>
INSERT_TIME	TIMESTAMP NOT NULL GENERATED ALWAYS FOR EACH ROW ON UPDATE AS ROW CHANGE TIMESTAMP	The time when the row was inserted or updated.

Table 414. Descriptions of columns in the DSN_PREDICATE_SELECTIVITY table (continued)

Column name	Data Type	Description
EXPLAIN_TIME	TIMESTAMP	<p>The time when the EXPLAIN information was captured:</p> <p>All cached statements When the statement entered the cache, in the form of a full-precision timestamp value.</p> <p>Non-cached static statements When the statement was bound, in the form of a full precision timestamp value.</p> <p>Non-cached dynamic statements When EXPLAIN was executed, in the form of a value equivalent to a CHAR(16) representation of the time appended by 4 zeros.</p>
REMARKS	VARCHAR(762)	IBM internal use only.
EXPANSION_REASON	CHAR(2) NOT NULL WITH DEFAULT	<p>This column applies only to statements that reference archive tables or temporal tables. For other statements, this column is blank.</p> <p>Indicates the effect of the CURRENT TEMPORAL BUSINESS_TIME special register, the CURRENT TEMPORAL SYSTEM_TIME special register, and the SYSIBMADM.GET_ARCHIVE built-in global variable. These items are controlled by the BUSTIMESENSITIVE, SYSTIMESENSITIVE, and ARCHIVESENSITIVE bind options.</p> <p>Db2 implicitly adds certain syntax to the query if one of the following conditions are true:</p> <ul style="list-style-type: none"> • The SYSIBMADM.GET_ARCHIVE global variable is set to Y and the ARCHIVESENSITIVE bind option is set to YES • The CURRENT TEMPORAL BUSINESS_TIME special register is not null and the BUSTIMESENSITIVE bind option is set to YES • The CURRENT TEMPORAL SYSTEM_TIME special register is not null and the SYSTIMESENSITIVE bind option is set to YES

Table 414. Descriptions of columns in the DSN_PREDICATE_SELECTIVITY table (continued)

Column name	Data Type	Description
EXPANSION_REASON (continued)		<p>This column can have one of the following values:</p> <p>'A' The query contains implicit query transformation as a result of the SYSIBMADM.GET_ARCHIVE built-in global variable.</p> <p>'B' The query contains implicit query transformation as a result of the CURRENT TEMPORAL BUSINESS_TIME special register.</p> <p>'S' The query contains implicit query transformation as a result of the CURRENT TEMPORAL SYSTEM_TIME special register.</p> <p>'SB' The query contains implicit query transformation as a result of the CURRENT TEMPORAL SYSTEM_TIME special register and the CURRENT TEMPORAL BUSINESS_TIME special register.</p> <p>blank The query does not contain implicit query transformation.</p>
PER_STMT_ID	BIGINT NOT NULL	<p>The persistent statement identifier for SQL statements in Db2 catalog tables.</p> <p>For example, this column corresponds to the following catalog table columns that identify SQL statements:</p> <ul style="list-style-type: none"> • STMT_ID in SYSIBM.SYSPACKSTMT, for SQL statements in packages. • SDQ_STMT_ID in SYSIBM.SYSDYNQUERY, for stabilized dynamic SQL statements.

◀ PSPI

Related tasks

[Overriding predicate selectivities at the statement level \(Db2 Performance\)](#)

Related reference

[BIND QUERY subcommand \(DSN\) \(Db2 Commands\)](#)

[DSN_PREDICAT_TABLE \(Db2 Performance\)](#)

[Tables for influencing access path selection \(Db2 Performance\)](#)

DSN_PTASK_TABLE

The parallel tasks table, DSN_PTASK_TABLE, contains information about all of the parallel tasks in a query.

PSPi

Recommendation: Do not manually insert data into system-maintained EXPLAIN tables, and use care when deleting obsolete EXPLAIN table data. The data is intended to be manipulated only by the Db2 EXPLAIN function and optimization tools. Certain optimization tools depend on instances of the various EXPLAIN tables. Be careful not to delete data from or drop instances EXPLAIN tables that are created for these tools.

Qualifiers

Your subsystem or data sharing group can contain multiple instances of these tables that are qualified by user ID. These tables are populated with statement cost information when you issue the EXPLAIN statement or bind. They are also populated when you specify EXPLAIN(YES) or EXPLAIN(ONLY) in a BIND or REBIND command. SQL optimization tools might also create EXPLAIN tables that are qualified by a user ID. You can find the SQL statement for creating an instance of these tables in member DSNTESC of the SDSNSAMP library.

Sample CREATE TABLE statement

You can find a sample CREATE TABLE statement for each EXPLAIN table in member DSNTESC of the *prefix*.SDSNSAMP library. You can call the ADMIN_EXPLAIN_MAINT stored procedure to create EXPLAIN tables, upgrade them to the format for the current Db2 release, or complete other maintenance tasks. See [“ADMIN_EXPLAIN_MAINT stored procedure” on page 751](#) for information about using the *action* input parameter to request each of these tasks.

Column descriptions

The following table describes the columns of DSN_PTASK_TABLE.

Table 415. DSN_PTASK_TABLE description

Column name	Data type	Description
QUERYNO	INTEGER NOT NULL	<p>A number that identifies the statement that is being explained. The origin of the value depends on the context of the row:</p> <p>For rows produced by EXPLAIN statements The number specified in the QUERYNO clause, which is an optional part of the SELECT, INSERT, UPDATE, MERGE, and DELETE statement syntax.</p> <p>For rows not produced by EXPLAIN statements Db2 assigns a number that is based on the line number of the SQL statement in the source program.</p> <p>When the values of QUERYNO are based on the statement number in the source program, values that exceed 32767 are reported as 0. However, in certain rare cases, the value is not guaranteed to be unique.</p> <p>When the SQL statement is embedded in a compiled SQL function, native SQL procedure, or advanced trigger, if the QUERYNO clause is specified, its value is used by Db2. Otherwise Db2 assigns a number based on the line number of the SQL statement in the compiled SQL function, native SQL procedure, or advanced trigger.</p>

Table 415. DSN_PTASK_TABLE description (continued)

Column name	Data type	Description
QBLOCKNO	SMALLINT NOT NULL	A number that identifies each query block within a query. The value of the numbers are not in any particular order, nor are they necessarily consecutive.
PGDNO	SMALLINT NOT NULL	The parallel group identifier within the current query block. This value corresponds to the value of the GROUPID column in DSN_PGGROUP_TABLE table rows.
APPLNAME	VARCHAR(24) NOT NULL	The name of the application plan for the row. Applies only to embedded EXPLAIN statements that are executed from a plan or to statements that are explained when binding a plan. A blank indicates that the column is not applicable. When the SQL statement is embedded in a compiled SQL function, native SQL procedure, or advanced trigger, this column is not used, and is blank.
PROGNAME	VARCHAR(128) NOT NULL	The name of the program or package containing the statement being explained. Applies only to embedded EXPLAIN statements and to statements explained as the result of binding a plan or package. A blank indicates that the column is not applicable. When the SQL statement is embedded in a compiled SQL function or native SQL procedure, this column indicates the specific name of the compiled SQL function or native SQL procedure. When the SQL statement is embedded in an advanced trigger, this column contains the name of the trigger.
LPTNO	SMALLINT NOT NULL	The parallel task number.
KEYCOLID	SMALLINT	The key column ID (KEY range only).
DPSI	CHAR(1) NOT NULL	Indicates if a data partition secondary index (DPSI) is used.
LPTLOKEY	VARCHAR(40) FOR BIT DATA	The low key value for this key column for this parallel task (KEY range only).
LPTHIKEY	VARCHAR(40) FOR BIT DATA	The high key value for this key column for this parallel task (KEY range only).
LPTLOPAG	CHAR(4) FOR BIT DATA	The low page information if partitioned by page range.
LPTLHIPAG	CHAR(4) FOR BIT DATA	The high page information if partitioned by page range.
LPTLOPG ¹ on page 2873	CHAR(4) FOR BIT DATA	The lower bound page number for this parallel task (Page range or DPSI enabled only).
LPTHIPG ¹ on page 2873	CHAR(4) FOR BIT DATA	The upper bound page number for this parallel task (Page range or DPSI enabled only).
LPTLOPT ¹ on page 2873	SMALLINT	The lower bound partition number for this parallel task (Page range or DPSI enabled only).
LPTHIPT ¹ on page 2873	SMALLINT	The upper bound partition number for this parallel task (Page range or DPSI enabled only).
KEYCOLDT	SMALLINT	The data type for this key column (KEY range only).

Table 415. DSN_PTASK_TABLE description (continued)

Column name	Data type	Description
KEYCOLPREC	SMALLINT	The precision/length for this key column (KEY range only).
KEYCOLSCAL	SMALLINT	The scale for this key column (KEY range with Decimal datatype only).
EXPLAIN_TIME	TIMESTAMP NOT NULL	<p>The time when the EXPLAIN information was captured:</p> <p>All cached statements When the statement entered the cache, in the form of a full-precision timestamp value.</p> <p>Non-cached static statements When the statement was bound, in the form of a full precision timestamp value.</p> <p>Non-cached dynamic statements When EXPLAIN was executed, in the form of a value equivalent to a CHAR(16) representation of the time appended by 4 zeros.</p>
GROUP_MEMBER	VARCHAR(24) NOT NULL	The member name of the Db2 that executed EXPLAIN. The column is blank if the Db2 subsystem was not in a data sharing environment when EXPLAIN was executed.
SECTNOI	INTEGER NOT NULL WITH DEFAULT WITH DEFAULT	The section number of the statement. The value is taken from the same column in SYSPACKSTMT or SYSSTMT tables and can be used to join tables to reconstruct the access path for the statement. This column is applicable only for static statements. The default value of -1 indicates EXPLAIN information that was captured in DB2 9 or earlier.
COLLID	VARCHAR(128) NOT NULL WITH DEFAULT	<p>The collection ID:</p> <p>'DSNEXPLAINMODEYES' The row originates from an application that specifies YES for the value of the CURRENT EXPLAIN MODE special register.</p> <p>'DSNEXPLAINMODEEXPLAIN' The row originates from an application that specifies EXPLAIN for the value of the CURRENT EXPLAIN MODE special register.</p> <p>When the SQL statement is embedded in a compiled SQL function, native SQL procedure, or advanced trigger, this column indicates the schema name of the compiled SQL function, native SQL procedure, or advanced trigger.</p>

Table 415. DSN_PTASK_TABLE description (continued)

Column name	Data type	Description
VERSION	VARCHAR(122) NOT NULL WITH DEFAULT	<p>The version identifier for the package. Applies only to an embedded EXPLAIN statement executed from a package or to a statement that is explained when binding a package.</p> <p>If the value is not blank, the value is the same as the VERSION value for the package that was used to create this EXPLAIN table row.</p> <p>The value is blank for a statement in:</p> <ul style="list-style-type: none">• A package for a basic trigger (TYPE='T')• A package for an application that was precompiled without SQL processing option VERSION• A package that was precompiled with an empty string for the VERSION value (TYPE=blank) <p>When the SQL statement is embedded in a compiled SQL function or native SQL procedure, this column indicates the version identifier of the function or procedure. When the SQL statement is embedded in an advanced trigger body, this column is not used and will be blank.</p>

Table 415. DSN_PTASK_TABLE description (continued)

Column name	Data type	Description
EXPANSION_REASON	CHAR(2) NOT NULL WITH DEFAULT	<p>This column applies only to statements that reference archive tables or temporal tables. For other statements, this column is blank.</p> <p>Indicates the effect of the CURRENT TEMPORAL BUSINESS_TIME special register, the CURRENT TEMPORAL SYSTEM_TIME special register, and the SYSIBMADM.GET_ARCHIVE built-in global variable. These items are controlled by the BUSTIMESENSITIVE, SYSTIMESENSITIVE, and ARCHIVESENSITIVE bind options.</p> <p>Db2 implicitly adds certain syntax to the query if one of the following conditions are true:</p> <ul style="list-style-type: none"> • The SYSIBMADM.GET_ARCHIVE global variable is set to Y and the ARCHIVESENSITIVE bind option is set to YES • The CURRENT TEMPORAL BUSINESS_TIME special register is not null and the BUSTIMESENSITIVE bind option is set to YES • The CURRENT TEMPORAL SYSTEM_TIME special register is not null and the SYSTIMESENSITIVE bind option is set to YES <p>This column can have one of the following values:</p> <p>'A' The query contains implicit query transformation as a result of the SYSIBMADM.GET_ARCHIVE built-in global variable.</p> <p>'B' The query contains implicit query transformation as a result of the CURRENT TEMPORAL BUSINESS_TIME special register.</p> <p>'S' The query contains implicit query transformation as a result of the CURRENT TEMPORAL SYSTEM_TIME special register.</p> <p>'SB' The query contains implicit query transformation as a result of the CURRENT TEMPORAL SYSTEM_TIME special register and the CURRENT TEMPORAL BUSINESS_TIME special register.</p> <p>blank The query does not contain implicit query transformation.</p>
PER_STMT_ID	BIGINT NOT NULL	<p>The persistent statement identifier for SQL statements in Db2 catalog tables.</p> <p>For example, this column corresponds to the following catalog table columns that identify SQL statements:</p> <ul style="list-style-type: none"> • STMT_ID in SYSIBM.SYSPACKSTMT, for SQL statements in packages. • SDQ_STMT_ID in SYSIBM.SYSDYNQUERY, for stabilized dynamic SQL statements.
AP_PLANID	CHAR(16) FOR BIT DATA	A unique identifier for BIND or PREPARE optimizations for an SQL statement, in the form of an extended timestamp value.

Notes:

1. The name of these columns originally contained the # symbol as the last character in the names. However, the names that contain these characters are obsolete and are no longer supported.

DSN_QUERYINFO_TABLE

The query information table, DSN_QUERYINFO_TABLE, contains information about the eligibility of query blocks for automatic query rewrite, information about the materialized query tables that are considered for eligible query blocks, reasons why ineligible query blocks are not eligible, and information about acceleration of query blocks.

Recommendation: Do not manually insert data into system-maintained EXPLAIN tables, and use care when deleting obsolete EXPLAIN table data. The data is intended to be manipulated only by the Db2 EXPLAIN function and optimization tools. Certain optimization tools depend on instances of the various EXPLAIN tables. Be careful not to delete data from or drop instances EXPLAIN tables that are created for these tools.

Qualifiers

Your subsystem or data sharing group can contain more than one of these tables:

userID

You can create additional instances of EXPLAIN tables that are qualified by user ID. These tables are populated with statement cost information when you issue the EXPLAIN statement or bind, or rebind, a plan or package with the EXPLAIN(YES) option. SQL optimization tools might also create EXPLAIN tables that are qualified by a user ID. You can find the SQL statement for creating an instance of these tables in member DSNTESC of the SDSNSAMP library.

Sample CREATE TABLE statement

You can find a sample CREATE TABLE statement for each EXPLAIN table in member DSNTESC of the *prefix*.SDSNSAMP library. You can call the ADMIN_EXPLAIN_MAINT stored procedure to create EXPLAIN tables, upgrade them to the format for the current Db2 release, or complete other maintenance tasks. See [“ADMIN_EXPLAIN_MAINT stored procedure” on page 751](#) for information about using the *action* input parameter to request each of these tasks.

Column descriptions

Table 416. Descriptions of columns in DSN_QUERYINFO_TABLE

Column name	Data type	Description
QUERYNO	INTEGER NOT NULL	<p>A number that identifies the statement that is being explained. The origin of the value depends on the context of the row:</p> <p>For rows produced by EXPLAIN statements The number specified in the QUERYNO clause, which is an optional part of the SELECT, INSERT, UPDATE, MERGE, and DELETE statement syntax.</p> <p>For rows not produced by EXPLAIN statements Db2 assigns a number that is based on the line number of the SQL statement in the source program.</p> <p>When the values of QUERYNO are based on the statement number in the source program, values that exceed 32767 are reported as 0. However, in certain rare cases, the value is not guaranteed to be unique.</p> <p>When the SQL statement is embedded in a compiled SQL function, native SQL procedure, or advanced trigger, if the QUERYNO clause is specified, its value is used by Db2. Otherwise Db2 assigns a number based on the line number of the SQL statement in the compiled SQL function, native SQL procedure, or advanced trigger.</p>
QBLOCKNO	SMALLINT NOT NULL	<p>A number that identifies each query block within a query. The value of the numbers are not in any particular order, nor are they necessarily consecutive.</p>
QINAME1	VARCHAR(128) NOT NULL WITH DEFAULT	<p>When TYPE='A':</p> <ul style="list-style-type: none"> When REASON_CODE=0, this value is the name of the accelerator server to which the statement is sent. When REASON_CODE<>0, the statement was not sent to an accelerator server. The REASON_CODE value indicates why the statement was not sent to the accelerator server. <p>When TYPE='ACCELMDL', this statement used accelerator modeling.</p> <p>For static queries, the value in this field might be the name of the accelerator server that is available at execution time.</p>
QINAME2	VARCHAR(128) NOT NULL WITH DEFAULT	<p>When TYPE='A' and REASON_CODE=0, this value is the name of the location name of the accelerator server to which the statement is sent.</p> <p>For static queries, the value in this field might be the name of the accelerator server that is available at execution time.</p>
APPLNAME	VARCHAR(24) NOT NULL	<p>The name of the application plan for the row. Applies only to embedded EXPLAIN statements that are executed from a plan or to statements that are explained when binding a plan. A blank indicates that the column is not applicable.</p> <p>When the SQL statement is embedded in a compiled SQL function, native SQL procedure, or advanced trigger, this column is not used, and is blank.</p>

Table 416. Descriptions of columns in DSN_QUERYINFO_TABLE (continued)

Column name	Data type	Description
PROGNAME	VARCHAR(128) NOT NULL	<p>The name of the program or package containing the statement being explained. Applies only to embedded EXPLAIN statements and to statements explained as the result of binding a plan or package. A blank indicates that the column is not applicable.</p> <p>When the SQL statement is embedded in a compiled SQL function or native SQL procedure, this column indicates the specific name of the compiled SQL function or native SQL procedure. When the SQL statement is embedded in an advanced trigger, this column contains the name of the trigger.</p>
VERSION	VARCHAR(122) NOT NULL	<p>The version identifier for the package. Applies only to an embedded EXPLAIN statement executed from a package or to a statement that is explained when binding a package.</p> <p>If the value is not blank, the value is the same as the VERSION value for the package that was used to create this EXPLAIN table row.</p> <p>The value is blank for a statement in:</p> <ul style="list-style-type: none"> • A package for a basic trigger (TYPE='T') • A package for an application that was precompiled without SQL processing option VERSION • A package that was precompiled with an empty string for the VERSION value (TYPE=blank) <p>When the SQL statement is embedded in a compiled SQL function or native SQL procedure, this column indicates the version identifier of the function or procedure. When the SQL statement is embedded in an advanced trigger body, this column is not used and will be blank.</p>
COLLID	VARCHAR(128) NOT NULL	<p>The collection ID:</p> <p>'DSNEXPLAINMODEYES' The row originates from an application that specifies YES for the value of the CURRENT EXPLAIN MODE special register.</p> <p>'DSNEXPLAINMODEEXPLAIN' The row originates from an application that specifies EXPLAIN for the value of the CURRENT EXPLAIN MODE special register.</p> <p>When the SQL statement is embedded in a compiled SQL function, native SQL procedure, or advanced trigger, this column indicates the schema name of the compiled SQL function, native SQL procedure, or advanced trigger.</p>
GROUP_MEMBER	VARCHAR(24) NOT NULL	<p>The member name of the Db2 that executed EXPLAIN. The column is blank if the Db2 subsystem was not in a data sharing environment when EXPLAIN was executed.</p>

Table 416. Descriptions of columns in DSN_QUERYINFO_TABLE (continued)

Column name	Data type	Description
SECTNOI	INTEGER NOT NULL WITH DEFAULT	The section number of the statement. The value is taken from the same column in SYSPACKSTMT or SYSSTMT tables and can be used to join tables to reconstruct the access path for the statement. This column is applicable only for static statements. The default value of -1 indicates EXPLAIN information that was captured in DB2 9 or earlier.
SEQNO	INTEGER NOT NULL WITH DEFAULT	The sequence number for this row if QI_DATA exceeds the size of its column.
EXPLAIN_TIME	TIMESTAMP NOT NULL	The time when the EXPLAIN information was captured: All cached statements When the statement entered the cache, in the form of a full-precision timestamp value. Non-cached static statements When the statement was bound, in the form of a full precision timestamp value. Non-cached dynamic statements When EXPLAIN was executed, in the form of a value equivalent to a CHAR(16) representation of the time appended by 4 zeros.
TYPE	CHAR(8) NOT NULL WITH DEFAULT	The type of the output for this row: A This row is for a statement that Db2 attempts to run on an accelerator server. The value in column REASON_CODE indicates the outcome.
REASON_CODE	SMALLINT NOT NULL WITH DEFAULT	The reason code for the row when TYPE='A'. For a description of the meaning, see “REASON_CODE values” on page 2878 . You can also check the QI_DATA column value, which might contain more specific information.
QI_DATA	CLOB(2M) NOT NULL WITH DEFAULT	When TYPE='A': <ul style="list-style-type: none"> For REASON_CODE values other than 0, this value is a description of the REASON_CODE value. For more information, see “REASON_CODE values” on page 2878. For a REASON_CODE value of 0, this value is the statement text, after it is converted for processing by the accelerator.
SERVICE_INFO	BLOB(2M) NOT NULL WITH DEFAULT	IBM internal use only.
QB_INFO_ROWID	ROWID NOT NULL GENERATED ALWAYS	IBM internal use only.

Table 416. Descriptions of columns in DSN_QUERYINFO_TABLE (continued)

Column name	Data type	Description
EXPANSION_REASON	CHAR(2) NOT NULL WITH DEFAULT	<p>This column applies only to statements that reference archive tables or temporal tables. For other statements, this column is blank.</p> <p>Indicates the effect of the CURRENT TEMPORAL BUSINESS_TIME special register, the CURRENT TEMPORAL SYSTEM_TIME special register, and the SYSIBMADM.GET_ARCHIVE built-in global variable. These items are controlled by the BUSTIMESENSITIVE, SYSTIMESENSITIVE, and ARCHIVESENSITIVE bind options.</p> <p>Db2 implicitly adds certain syntax to the query if one of the following conditions are true:</p> <ul style="list-style-type: none"> • The SYSIBMADM.GET_ARCHIVE global variable is set to Y and the ARCHIVESENSITIVE bind option is set to YES • The CURRENT TEMPORAL BUSINESS_TIME special register is not null and the BUSTIMESENSITIVE bind option is set to YES • The CURRENT TEMPORAL SYSTEM_TIME special register is not null and the SYSTIMESENSITIVE bind option is set to YES <p>This column can have one of the following values:</p> <p>'A' The query contains implicit query transformation as a result of the SYSIBMADM.GET_ARCHIVE built-in global variable.</p> <p>'B' The query contains implicit query transformation as a result of the CURRENT TEMPORAL BUSINESS_TIME special register.</p> <p>'S' The query contains implicit query transformation as a result of the CURRENT TEMPORAL SYSTEM_TIME special register.</p> <p>'SB' The query contains implicit query transformation as a result of the CURRENT TEMPORAL SYSTEM_TIME special register and the CURRENT TEMPORAL BUSINESS_TIME special register.</p> <p>blank The query does not contain implicit query transformation.</p>
AP_PLANID	CHAR(16) FOR BIT DATA	A unique identifier for BIND or PREPARE optimizations for an SQL statement, in the form of an extended timestamp value.

REASON_CODE values

The REASON_CODE values correspond in most cases to the *reason-code* values that are returned with SQL code [-4742](#).

For rows with non-zero REASON_CODE values, the QI_DATA column contains a description of reason code, sometimes with specific values included.

0

The query block qualifies for routing to an accelerator server. The values of QINAME1 and QINAME2 identify the accelerator server.

For example, for version 1 of IBM Db2 Analytics Accelerator for z/OS, the associated data mart name is recorded in the QINAME2 column, with the following naming convention: *data-mart-name@accelerator-name@digits*.

The QI_DATA column contains the statement text, after it is converted for processing by the accelerator.

- 1** No active accelerator server was found or the table was not enabled for query acceleration when the statement was executed.
- 2** The CURRENT QUERY ACCELERATION special register is set to NONE.
- 3** Db2 classified the query as a short-running query, or Db2 determined that sending the query to an accelerator server provided no performance advantage.
- 4** The query is not read-only.
- 6** The cursor is defined as scrollable or is a rowset-positioned cursor.
- 7** The query references objects with multiple encoding schemes.
- 8** The FROM clause of the query specifies a *data-change-table-reference*.
- 9** The query contains a table expression with one or more correlated references to other tables in the same FROM clause.
- 10** The query contains a recursive reference to a common table expression.
- 11** The query contains an unsupported expression. The text of the expression is in QI_DATA.
- 12** The query references a table that has any of the following characteristics:
 - Is not defined in the accelerator server
 - Is defined in a different accelerator server from another table in the query
 - Is defined in the accelerator server, but is not enabled for query acceleration
- 13** The accelerator server that contains the tables that are referenced in the query is not started.
- 14** A column that is referenced in the query was altered in Db2 after the data was loaded in the accelerator server.
- 15** The query uses functionality that is available only in DB2 10 or later, and the functionality is not supported by the accelerator server.
- 17** The query is an INSERT from SELECT statement. Subsystem parameter QUERY_ACCEL_OPTIONS does not specify option 2 to enable the acceleration of INSERT from SELECT statements.
- 18** The query uses functionality that is available only in Db2 11 or later, and the functionality is not supported by the accelerator server.

19

The accelerator server is not at the correct level and does not support a function in the SQL statement. The QI_DATA column contains the function text or expression text that is using the unsupported function for the accelerator server.

20

The query is a rowset cursor that is declared WITH RETURN, executes remotely, or executes under an SQL PL routine.

21

The query contains a correlated subquery that is not supported for acceleration.

22

The statement references an accelerator-only table, but the statement cannot run on the accelerator. For example:

- MERGE statement references an accelerator-only table.
- UPDATE or DELETE statement references an accelerator-only table, but the target table of the UPDATE, DELETE is a normal Db2 table: UPDATE DB2_TABLE SET .. (SELECT .. FROM ACCEL_ONLY_TABLE).
- INSERT, UPDATE or DELETE of a *row-fullselect* with subselect. UPDATE ACCEL_ONLY_TABLE SET (C1, C2) = (SELECT C3, C4 FROM TABLE2);

23

The SELECT INTO statement is bound for acceleration but is run as a remote SELECT INTO statement, which is not supported for acceleration.

24

The DDL or DML statement cannot run on the accelerator because the connection to the accelerator server does not allow updates. This problem can occur when a two-phase commit requester (for example, a Db2 for z/OS requester) connects to a Db2 for z/OS server to run a DDL or DML statement on an accelerator.

25

The statement contains a reference to a column with an unsupported data type.

26

FL 509 The CREATE TABLE statement clause IN ACCELERATOR specifies an accelerator alias that resolves to more than one accelerator and at least one of the following conditions is true:

- Your Db2 function level is lower than V12R1M509.
- The SYSACCEL.SYSACCELERATEDTABLES table does not have the FEATURE column.

27

The DROP TABLE statement specifies a referencing accelerator-only table, which cannot be removed by using the DROP TABLE statement.

28

FL 509 The SQL INSERT, UPDATE, or DELETE statement references a high availability accelerator-only table (AOT) that is defined in multiple accelerators and one of the following conditions is true:

- Neither the CURRENT ACCELERATOR special register nor the ACCELERATOR bind option is used.
- The CURRENT ACCELERATOR special register or the ACCELERATOR bind option specifies one of the following values:
 - An alias that resolves to multiple accelerators. The alias must resolve to one V7 or later accelerator.
 - An accelerator that is not a V7 or later accelerator. A V7 or later accelerator is required to execute the SQL statement.
 - An accelerator that does not exist or is not available when the SQL statement is executed.
 - An accelerator that is not qualified to execute the SQL statement for a high availability AOT.

29

During a Db2 for z/OS special runtime incremental bind of a static query that was originally bound for acceleration with the QUERYACCELERATION bind option value of ELIGIBLE or ENABLE (not ENABLEWITHFAILBACK), the query cannot be bound for acceleration to the target accelerator that Db2 has selected for this particular run of the query. This special incremental bind usually occurs for one of the following reasons:

- The user table has been dropped and re-created in Db2 for z/OS but has not been refreshed in the target accelerator since the last time the static query was bound for acceleration.
- The archive status of the user table in the target accelerator has changed since the last time the static query was bound for acceleration.

Failure to bind the static query for acceleration during this incremental bind can occur if the user table in the target accelerator is down-level from the current definition of that table in the Db2 for z/OS catalog. This failure might also occur due to other reasons.

30

Accelerator WAITFORDATA behavior is requested but cannot be achieved for this query. The query will not be accelerated. The query specifies a Db2 accelerated table, but the same Db2 unit of work includes a previous uncommitted Db2 change that will not be available to the query when it is run on the accelerator. The Db2 change might or might not be related to the Db2 accelerated table that is referenced in the query.

31

Accelerator WAITFORDATA behavior is requested but cannot be achieved for this query that specifies both an accelerator-only table (AOT) and a Db2 accelerated table. The query will not be accelerated and cannot be run in Db2. The same Db2 unit of work includes a previous uncommitted Db2 change that will not be available to the query when it is run on the accelerator. The change might or might not be related to the Db2 accelerated table that is referenced in the query.

32

Accelerator WAITFORDATA behavior is requested but cannot be achieved for this query. The query will not be accelerated. The query specifies a Db2 accelerated table, but the same Db2 unit of work includes a previous uncommitted accelerator-only table (AOT) change. This uncommitted change resulted in the creation of an accelerator database *snapshot isolation* (SI) for this unit of work before the query was run. This accelerator database SI can prevent committed and replicated Db2 changes, made either by this transaction or by a different transaction, from being available to the accelerated query, even if the Db2 changes are replicated to the accelerator before the query is run there.

33

The query could not run on the accelerator due to different reasons on different versions of the accelerator.

34

The statement included an expression that can run on an accelerator server only when the CURRENT QUERY ACCELERATION special register is set to ALL, ENABLE, or ELIGIBLE. However, the CURRENT QUERY ACCELERATION special register is set to NONE or ENABLE WITH FAILBACK.

See the programmer responses for the two different REASON_CODE values for the corresponding version of the accelerator.

35

The query uses functionality that is available only in Db2 12 or later, and the accelerator server does not support the functionality.

36

The USE ONLY NEW ACCELERATOR_TYPE subsystem parameter is set to YES; however, either an active V7 or later accelerator was not found or the table was not enabled for query acceleration in the V7 or later accelerator when the statement was executed.

37

The USE ONLY NEW ACCELERATOR_TYPE subsystem parameter is set to YES, but the V7 or later accelerator that contains the tables of the query is not started.

38

The USE ONLY NEW ACCELERATOR_TYPE subsystem parameter is set to YES, but the V7 or later accelerator is not at the correct level.

42

The SYSACCEL.SYSACCELERATORS or SYSACCEL.SYSACCELERATEDTABLES tables are not found.

900-999

For IBM internal use only.

Related information

[IBM Db2 Analytics Accelerator for z/OS documentation](#)

DSN_QUERY_TABLE

The query table, DSN_QUERY_TABLE, contains information about a SQL statement, and displays the statement before and after query transformation.

PSPI

Unlike other EXPLAIN tables, rows in DSN_QUERY_TABLE are not populated for static SQL statements at BIND or REBIND with the EXPLAIN(YES) option.

Recommendation: Do not manually insert data into system-maintained EXPLAIN tables, and use care when deleting obsolete EXPLAIN table data. The data is intended to be manipulated only by the Db2 EXPLAIN function and optimization tools. Certain optimization tools depend on instances of the various EXPLAIN tables. Be careful not to delete data from or drop instances EXPLAIN tables that are created for these tools.

Qualifiers

Your subsystem or data sharing group can contain multiple instances of these tables that are qualified by user ID. These tables are populated with statement cost information when you issue the EXPLAIN statement or bind. They are also populated when you specify EXPLAIN(YES) or EXPLAIN(ONLY) in a BIND or REBIND command. SQL optimization tools might also create EXPLAIN tables that are qualified by a user ID. You can find the SQL statement for creating an instance of these tables in member DSNTESC of the SDSNSAMP library.

Sample CREATE TABLE statement

You can find a sample CREATE TABLE statement for each EXPLAIN table in member DSNTESC of the *prefix*.SDSNSAMP library. You can call the ADMIN_EXPLAIN_MAINT stored procedure to create EXPLAIN tables, upgrade them to the format for the current Db2 release, or complete other maintenance tasks. See [“ADMIN_EXPLAIN_MAINT stored procedure” on page 751](#) for information about using the *action* input parameter to request each of these tasks.

Column descriptions

The following table describes the columns of DSN_QUERY_TABLE.

Table 417. DSN_QUERY_TABLE description

Column name	Data type	Description
QUERYNO	INTEGER NOT NULL	<p>A number that identifies the statement that is being explained. The origin of the value depends on the context of the row:</p> <p>For rows produced by EXPLAIN statements The number specified in the QUERYNO clause, which is an optional part of the SELECT, INSERT, UPDATE, MERGE, and DELETE statement syntax.</p> <p>For rows not produced by EXPLAIN statements Db2 assigns a number that is based on the line number of the SQL statement in the source program.</p> <p>When the values of QUERYNO are based on the statement number in the source program, values that exceed 32767 are reported as 0. However, in certain rare cases, the value is not guaranteed to be unique.</p> <p>When the SQL statement is embedded in a compiled SQL function, native SQL procedure, or advanced trigger, if the QUERYNO clause is specified, its value is used by Db2. Otherwise Db2 assigns a number based on the line number of the SQL statement in the compiled SQL function, native SQL procedure, or advanced trigger.</p>
TYPE	CHAR(8) NOT NULL	The type of the data in the NODE_DATA column.
QUERY_STAGE	CHAR(8) NOT NULL WITH DEFAULT	The stage during query transformation when this row is populated.
SEQNO	NOT NULL	The sequence number for this row if NODE_DATA exceeds the size of its column.
NODE_DATA	CLOB(2M)	The XML data containing the SQL statement and its query block, table, and column information.
EXPLAIN_TIME	TIMESTAMP	The EXPLAIN timestamp.
QUERY_ROWID	ROWID NOT NULL GENERATED ALWAYS	The ROWID of the statement.
GROUP_MEMBER	VARCHAR(24) NOT NULL	The member name of the Db2 subsystem that executed EXPLAIN. The column is blank if the Db2 subsystem was not in a data sharing environment when EXPLAIN was executed.
HASHKEY	INTEGER NOT NULL	The hash value of the contents in NODE_DATA
HAS_PRED	CHAR(1) NOT NULL	When NODE_DATA contains an SQL statement, this column indicates if the statement contains a parameter marker literal, non-parameter marker literal, or no predicates.
SECTNOI	INTEGER NOT NULL WITH DEFAULT	The section number of the statement. The value is taken from the same column in SYSPACKSTMT or SYSSTMT tables and can be used to join tables to reconstruct the access path for the statement. This column is applicable only for static statements. The default value of -1 indicates EXPLAIN information that was captured in DB2 9 or earlier.

Table 417. DSN_QUERY_TABLE description (continued)

Column name	Data type	Description
APPLNAME	VARCHAR(24) NOT NULL WITH DEFAULT	<p>The name of the application plan for the row. Applies only to embedded EXPLAIN statements that are executed from a plan or to statements that are explained when binding a plan. A blank indicates that the column is not applicable.</p> <p>When the SQL statement is embedded in a compiled SQL function, native SQL procedure, or advanced trigger, this column is not used, and is blank.</p>
PROGNAME	VARCHAR(128) NOT NULL WITH DEFAULT	<p>The name of the program or package containing the statement being explained. Applies only to embedded EXPLAIN statements and to statements explained as the result of binding a plan or package. A blank indicates that the column is not applicable.</p> <p>When the SQL statement is embedded in a compiled SQL function or native SQL procedure, this column indicates the specific name of the compiled SQL function or native SQL procedure. When the SQL statement is embedded in an advanced trigger, this column contains the name of the trigger.</p>
COLLID	VARCHAR(128) NOT NULL WITH DEFAULT	<p>The collection ID:</p> <p>'DSNEXPLAINMODEYES' The row originates from an application that specifies YES for the value of the CURRENT EXPLAIN MODE special register.</p> <p>'DSNEXPLAINMODEEXPLAIN' The row originates from an application that specifies EXPLAIN for the value of the CURRENT EXPLAIN MODE special register.</p> <p>When the SQL statement is embedded in a compiled SQL function, native SQL procedure, or advanced trigger, this column indicates the schema name of the compiled SQL function, native SQL procedure, or advanced trigger.</p>
VERSION	VARCHAR(122) NOT NULL WITH DEFAULT	<p>The version identifier for the package. Applies only to an embedded EXPLAIN statement executed from a package or to a statement that is explained when binding a package.</p> <p>If the value is not blank, the value is the same as the VERSION value for the package that was used to create this EXPLAIN table row.</p> <p>The value is blank for a statement in:</p> <ul style="list-style-type: none"> • A package for a basic trigger (TYPE='T') • A package for an application that was precompiled without SQL processing option VERSION • A package that was precompiled with an empty string for the VERSION value (TYPE=blank) <p>When the SQL statement is embedded in a compiled SQL function or native SQL procedure, this column indicates the version identifier of the function or procedure. When the SQL statement is embedded in an advanced trigger body, this column is not used and will be blank.</p>

Table 417. DSN_QUERY_TABLE description (continued)

Column name	Data type	Description
EXPANSION_REASON	CHAR(2) NOT NULL WITH DEFAULT	<p>This column applies only to statements that reference archive tables or temporal tables. For other statements, this column is blank.</p> <p>Indicates the effect of the CURRENT TEMPORAL BUSINESS_TIME special register, the CURRENT TEMPORAL SYSTEM_TIME special register, and the SYSIBMADM.GET_ARCHIVE built-in global variable. These items are controlled by the BUSTIMESENSITIVE, SYSTIMESENSITIVE, and ARCHIVESENSITIVE bind options.</p> <p>Db2 implicitly adds certain syntax to the query if one of the following conditions are true:</p> <ul style="list-style-type: none"> • The SYSIBMADM.GET_ARCHIVE global variable is set to Y and the ARCHIVESENSITIVE bind option is set to YES • The CURRENT TEMPORAL BUSINESS_TIME special register is not null and the BUSTIMESENSITIVE bind option is set to YES • The CURRENT TEMPORAL SYSTEM_TIME special register is not null and the SYSTIMESENSITIVE bind option is set to YES <p>This column can have one of the following values:</p> <p>'A' The query contains implicit query transformation as a result of the SYSIBMADM.GET_ARCHIVE built-in global variable.</p> <p>'B' The query contains implicit query transformation as a result of the CURRENT TEMPORAL BUSINESS_TIME special register.</p> <p>'S' The query contains implicit query transformation as a result of the CURRENT TEMPORAL SYSTEM_TIME special register.</p> <p>'SB' The query contains implicit query transformation as a result of the CURRENT TEMPORAL SYSTEM_TIME special register and the CURRENT TEMPORAL BUSINESS_TIME special register.</p> <p>blank The query does not contain implicit query transformation.</p>

PSPI

DSN_SORTKEY_TABLE

The sort key table, DSN_SORTKEY_TABLE, contains information about sort keys for all of the sorts required by a query.

PSPI

Recommendation: Do not manually insert data into system-maintained EXPLAIN tables, and use care when deleting obsolete EXPLAIN table data. The data is intended to be manipulated only by the Db2 EXPLAIN function and optimization tools. Certain optimization tools depend on instances of the various EXPLAIN tables. Be careful not to delete data from or drop instances EXPLAIN tables that are created for these tools.

Qualifiers

Your subsystem or data sharing group can contain multiple instances of these tables that are qualified by user ID. These tables are populated with statement cost information when you issue the EXPLAIN statement or bind. They are also populated when you specify EXPLAIN(YES) or EXPLAIN(ONLY) in a BIND or REBIND command. SQL optimization tools might also create EXPLAIN tables that are qualified by a user ID. You can find the SQL statement for creating an instance of these tables in member DSNTESC of the SDSNSAMP library.

Sample CREATE TABLE statement

You can find a sample CREATE TABLE statement for each EXPLAIN table in member DSNTESC of the *prefix*.SDSNSAMP library. You can call the ADMIN_EXPLAIN_MAINT stored procedure to create EXPLAIN tables, upgrade them to the format for the current Db2 release, or complete other maintenance tasks. See “ADMIN_EXPLAIN_MAINT stored procedure” on page 751 for information about using the *action* input parameter to request each of these tasks.

Column descriptions

The following table describes the columns of DSN_SORTKEY_TABLE.

Table 418. DSN_SORTKEY_TABLE description

Column name	Data type	Description
QUERYNO	INTEGER NOT NULL	<p>A number that identifies the statement that is being explained. The origin of the value depends on the context of the row:</p> <p>For rows produced by EXPLAIN statements The number specified in the QUERYNO clause, which is an optional part of the SELECT, INSERT, UPDATE, MERGE, and DELETE statement syntax.</p> <p>For rows not produced by EXPLAIN statements Db2 assigns a number that is based on the line number of the SQL statement in the source program.</p> <p>When the values of QUERYNO are based on the statement number in the source program, values that exceed 32767 are reported as 0. However, in certain rare cases, the value is not guaranteed to be unique.</p> <p>When the SQL statement is embedded in a compiled SQL function, native SQL procedure, or advanced trigger, if the QUERYNO clause is specified, its value is used by Db2. Otherwise Db2 assigns a number based on the line number of the SQL statement in the compiled SQL function, native SQL procedure, or advanced trigger.</p>
QBLOCKNO	SMALLINT NOT NULL	<p>A number that identifies each query block within a query. The value of the numbers are not in any particular order, nor are they necessarily consecutive.</p>
PLANNO	SMALLINT NOT NULL	<p>The plan number, a number used to identify each miniplan with a query block.</p>

Table 418. DSN_SORTKEY_TABLE description (continued)

Column name	Data type	Description
APPLNAME	VARCHAR(24) NOT NULL	<p>The name of the application plan for the row. Applies only to embedded EXPLAIN statements that are executed from a plan or to statements that are explained when binding a plan. A blank indicates that the column is not applicable.</p> <p>When the SQL statement is embedded in a compiled SQL function, native SQL procedure, or advanced trigger, this column is not used, and is blank.</p>
PROGNAME	VARCHAR(128) NOT NULL	<p>The name of the program or package containing the statement being explained. Applies only to embedded EXPLAIN statements and to statements explained as the result of binding a plan or package. A blank indicates that the column is not applicable.</p> <p>When the SQL statement is embedded in a compiled SQL function or native SQL procedure, this column indicates the specific name of the compiled SQL function or native SQL procedure. When the SQL statement is embedded in an advanced trigger, this column contains the name of the trigger.</p>
COLLID	VARCHAR(128) NOT NULL WITH DEFAULT	<p>The collection ID:</p> <p>'DSNEXPLAINMODEYES' The row originates from an application that specifies YES for the value of the CURRENT EXPLAIN MODE special register.</p> <p>'DSNEXPLAINMODEEXPLAIN' The row originates from an application that specifies EXPLAIN for the value of the CURRENT EXPLAIN MODE special register.</p> <p>When the SQL statement is embedded in a compiled SQL function, native SQL procedure, or advanced trigger, this column indicates the schema name of the compiled SQL function, native SQL procedure, or advanced trigger.</p>
SORTNO	SMALLINT NOT NULL	The sequence number of the sort
ORDERNO	SMALLINT NOT NULL	The sequence number of the sort key
EXPTYPE	CHAR(3) NOT NULL	<p>The type of the sort key. The possible values are:</p> <ul style="list-style-type: none"> • 'COL' • 'EXP' • 'QRY'
TEXT	VARCHAR(128) NOT NULL	The sort key text, can be a column name, an expression, or a scalar subquery, or 'Record ID'.
TABNO	SMALLINT NOT NULL	The table number, a number which uniquely identifies the corresponding table reference within a query.
COLNO	SMALLINT NOT NULL	The column number, a number which uniquely identifies the corresponding column within a query. Only applicable when the sort key is a column.

Table 418. DSN_SORTKEY_TABLE description (continued)

Column name	Data type	Description
DATATYPE	CHAR(18)	The data type of sort key. The possible values are <ul style="list-style-type: none"> 'HEXADECIMAL' 'CHARACTER' 'PACKED FIELD ' 'FIXED(31)' 'FIXED(15)' 'DATE' 'TIME' 'VARCHAR' 'PACKED FLD' 'FLOAT' 'TIMESTAMP' 'UNKNOWN DATA TYPE'
LENGTH	INTEGER NOT NULL	The length of sort key.
CCSID	INTEGER NOT NULL	IBM internal use only.
ORDERCLASS	INTEGER NOT NULL	IBM internal use only.
EXPLAIN_TIME	TIMESTAMP NOT NULL	The time when the EXPLAIN information was captured: <p>All cached statements When the statement entered the cache, in the form of a full-precision timestamp value.</p> <p>Non-cached static statements When the statement was bound, in the form of a full precision timestamp value.</p> <p>Non-cached dynamic statements When EXPLAIN was executed, in the form of a value equivalent to a CHAR(16) representation of the time appended by 4 zeros.</p>
GROUP_MEMBER	VARCHAR(24) NOT NULL	The member name of the Db2 that executed EXPLAIN. The column is blank if the Db2 subsystem was not in a data sharing environment when EXPLAIN was executed.
SECTNOI	INTEGER NOT NULL WITH DEFAULT	The section number of the statement. The value is taken from the same column in SYSPACKSTMT or SYSSTMT tables and can be used to join tables to reconstruct the access path for the statement. This column is applicable only for static statements. The default value of -1 indicates EXPLAIN information that was captured in DB2 9 or earlier.

Table 418. DSN_SORTKEY_TABLE description (continued)

Column name	Data type	Description
VERSION	VARCHAR(122) NOT NULL WITH DEFAULT	<p>The version identifier for the package. Applies only to an embedded EXPLAIN statement executed from a package or to a statement that is explained when binding a package.</p> <p>If the value is not blank, the value is the same as the VERSION value for the package that was used to create this EXPLAIN table row.</p> <p>The value is blank for a statement in:</p> <ul style="list-style-type: none">• A package for a basic trigger (TYPE='T')• A package for an application that was precompiled without SQL processing option VERSION• A package that was precompiled with an empty string for the VERSION value (TYPE=blank) <p>When the SQL statement is embedded in a compiled SQL function or native SQL procedure, this column indicates the version identifier of the function or procedure. When the SQL statement is embedded in an advanced trigger body, this column is not used and will be blank.</p>

Table 418. DSN_SORTKEY_TABLE description (continued)

Column name	Data type	Description
EXPANSION_REASON	CHAR(2) NOT NULL WITH DEFAULT	<p>This column applies only to statements that reference archive tables or temporal tables. For other statements, this column is blank.</p> <p>Indicates the effect of the CURRENT TEMPORAL BUSINESS_TIME special register, the CURRENT TEMPORAL SYSTEM_TIME special register, and the SYSIBMADM.GET_ARCHIVE built-in global variable. These items are controlled by the BUSTIMESENSITIVE, SYSTIMESENSITIVE, and ARCHIVESENSITIVE bind options.</p> <p>Db2 implicitly adds certain syntax to the query if one of the following conditions are true:</p> <ul style="list-style-type: none"> • The SYSIBMADM.GET_ARCHIVE global variable is set to Y and the ARCHIVESENSITIVE bind option is set to YES • The CURRENT TEMPORAL BUSINESS_TIME special register is not null and the BUSTIMESENSITIVE bind option is set to YES • The CURRENT TEMPORAL SYSTEM_TIME special register is not null and the SYSTIMESENSITIVE bind option is set to YES <p>This column can have one of the following values:</p> <p>'A' The query contains implicit query transformation as a result of the SYSIBMADM.GET_ARCHIVE built-in global variable.</p> <p>'B' The query contains implicit query transformation as a result of the CURRENT TEMPORAL BUSINESS_TIME special register.</p> <p>'S' The query contains implicit query transformation as a result of the CURRENT TEMPORAL SYSTEM_TIME special register.</p> <p>'SB' The query contains implicit query transformation as a result of the CURRENT TEMPORAL SYSTEM_TIME special register and the CURRENT TEMPORAL BUSINESS_TIME special register.</p> <p>blank The query does not contain implicit query transformation.</p>
PER_STMT_ID	BIGINT NOT NULL	<p>The persistent statement identifier for SQL statements in Db2 catalog tables.</p> <p>For example, this column corresponds to the following catalog table columns that identify SQL statements:</p> <ul style="list-style-type: none"> • STMT_ID in SYSIBM.SYSPACKSTMT, for SQL statements in packages. • SDQ_STMT_ID in SYSIBM.SYSDYNQUERY, for stabilized dynamic SQL statements.
AP_PLANID	CHAR(16) FOR BIT DATA	A unique identifier for BIND or PREPARE optimizations for an SQL statement, in the form of an extended timestamp value.

DSN_SORT_TABLE

The sort table, DSN_SORT_TABLE, contains information about the sort operations required by a query.

PSPI

Recommendation: Do not manually insert data into system-maintained EXPLAIN tables, and use care when deleting obsolete EXPLAIN table data. The data is intended to be manipulated only by the Db2 EXPLAIN function and optimization tools. Certain optimization tools depend on instances of the various EXPLAIN tables. Be careful not to delete data from or drop instances EXPLAIN tables that are created for these tools.

Qualifiers

Your subsystem or data sharing group can contain multiple instances of these tables that are qualified by user ID. These tables are populated with statement cost information when you issue the EXPLAIN statement or bind. They are also populated when you specify EXPLAIN(YES) or EXPLAIN(ONLY) in a BIND or REBIND command. SQL optimization tools might also create EXPLAIN tables that are qualified by a user ID. You can find the SQL statement for creating an instance of these tables in member DSNTESC of the SDSNSAMP library.

Sample CREATE TABLE statement

You can find a sample CREATE TABLE statement for each EXPLAIN table in member DSNTESC of the *prefix.SDSNSAMP* library. You can call the ADMIN_EXPLAIN_MAINT stored procedure to create EXPLAIN tables, upgrade them to the format for the current Db2 release, or complete other maintenance tasks. See [“ADMIN_EXPLAIN_MAINT stored procedure” on page 751](#) for information about using the *action* input parameter to request each of these tasks.

Column descriptions

The following table describes the columns of DSN_SORT_TABLE.

Table 419. DSN_SORT_TABLE description

Column name	Data type	Description
QUERYNO	INTEGER NOT NULL	<p>A number that identifies the statement that is being explained. The origin of the value depends on the context of the row:</p> <p>For rows produced by EXPLAIN statements The number specified in the QUERYNO clause, which is an optional part of the SELECT, INSERT, UPDATE, MERGE, and DELETE statement syntax.</p> <p>For rows not produced by EXPLAIN statements Db2 assigns a number that is based on the line number of the SQL statement in the source program.</p> <p>When the values of QUERYNO are based on the statement number in the source program, values that exceed 32767 are reported as 0. However, in certain rare cases, the value is not guaranteed to be unique.</p> <p>When the SQL statement is embedded in a compiled SQL function, native SQL procedure, or advanced trigger, if the QUERYNO clause is specified, its value is used by Db2. Otherwise Db2 assigns a number based on the line number of the SQL statement in the compiled SQL function, native SQL procedure, or advanced trigger.</p>

Table 419. DSN_SORT_TABLE description (continued)

Column name	Data type	Description
QBLOCKNO	SMALLINT NOT NULL	A number that identifies each query block within a query. The value of the numbers are not in any particular order, nor are they necessarily consecutive.
PLANNO	SMALLINT NOT NULL	The plan number, a number used to identify each miniplan with a query block.
APPLNAME	VARCHAR(24) NOT NULL	The name of the application plan for the row. Applies only to embedded EXPLAIN statements that are executed from a plan or to statements that are explained when binding a plan. A blank indicates that the column is not applicable. When the SQL statement is embedded in a compiled SQL function, native SQL procedure, or advanced trigger, this column is not used, and is blank.
PROGNAME	VARCHAR(128) NOT NULL	The name of the program or package containing the statement being explained. Applies only to embedded EXPLAIN statements and to statements explained as the result of binding a plan or package. A blank indicates that the column is not applicable. When the SQL statement is embedded in a compiled SQL function or native SQL procedure, this column indicates the specific name of the compiled SQL function or native SQL procedure. When the SQL statement is embedded in an advanced trigger, this column contains the name of the trigger.
COLLID	VARCHAR(128) NOT NULL	The collection ID: 'DSNEXPLAINMODEYES' The row originates from an application that specifies YES for the value of the CURRENT EXPLAIN MODE special register. 'DSNEXPLAINMODEEXPLAIN' The row originates from an application that specifies EXPLAIN for the value of the CURRENT EXPLAIN MODE special register. When the SQL statement is embedded in a compiled SQL function, native SQL procedure, or advanced trigger, this column indicates the schema name of the compiled SQL function, native SQL procedure, or advanced trigger.
SORTC	CHAR(5) NOT NULL WITH DEFAULT	Indicates the reasons for sort of the composite table. The reasons are shown as a series of bytes: <ul style="list-style-type: none"> • Byte 1 is 'G' if the reason is GROUP BY, or otherwise blank. • The second byte is 'J' if the reason is JOIN, or otherwise blank. • Byte is 'O' if the reason is ORDER BY, or otherwise blank. • The fourth by is 'U' if the reason is uniqueness, or otherwise blank.

Table 419. DSN_SORT_TABLE description (continued)

Column name	Data type	Description
SORTN	CHAR(5) NOT NULL WITH DEFAULT	<p>Indicates the reasons for sort of the new table. The reasons are shown as a series of bytes:</p> <ul style="list-style-type: none"> • The first byte is 'G' if the reason is GROUP BY, or otherwise blank. • The second byte is 'J' if the reason is JOIN, or otherwise blank. • The third byte is 'O' if the reason is ORDER BY, or otherwise blank. • The fourth by is 'U' if the reason is uniqueness, or otherwise blank.
SORTNO	SMALLINT NOT NULL	The sequence number of the sort.
KEYSIZE	SMALLINT NOT NULL	The sum of the lengths of the sort keys.
ORDERCLASS	INTEGER NOT NULL	IBM internal use only.
EXPLAIN_TIME	TIMESTAMP NOT NULL	<p>The time when the EXPLAIN information was captured:</p> <p>All cached statements When the statement entered the cache, in the form of a full-precision timestamp value.</p> <p>Non-cached static statements When the statement was bound, in the form of a full precision timestamp value.</p> <p>Non-cached dynamic statements When EXPLAIN was executed, in the form of a value equivalent to a CHAR(16) representation of the time appended by 4 zeros.</p>
GROUP_MEMBER	VARCHAR(24) NOT NULL	The member name of the Db2 that executed EXPLAIN. The column is blank if the Db2 subsystem was not in a data sharing environment when EXPLAIN was executed.
SECTNOI	INTEGER NOT NULL WITH DEFAULT	The section number of the statement. The value is taken from the same column in SYSPACKSTMT or SYSSTMT tables and can be used to join tables to reconstruct the access path for the statement. This column is applicable only for static statements. The default value of -1 indicates EXPLAIN information that was captured in DB2 9 or earlier.

Table 419. DSN_SORT_TABLE description (continued)

Column name	Data type	Description
VERSION	VARCHAR(122) NOT NULL WITH DEFAULT	<p>The version identifier for the package. Applies only to an embedded EXPLAIN statement executed from a package or to a statement that is explained when binding a package.</p> <p>If the value is not blank, the value is the same as the VERSION value for the package that was used to create this EXPLAIN table row.</p> <p>The value is blank for a statement in:</p> <ul style="list-style-type: none">• A package for a basic trigger (TYPE='T')• A package for an application that was precompiled without SQL processing option VERSION• A package that was precompiled with an empty string for the VERSION value (TYPE=blank) <p>When the SQL statement is embedded in a compiled SQL function or native SQL procedure, this column indicates the version identifier of the function or procedure. When the SQL statement is embedded in an advanced trigger body, this column is not used and will be blank.</p>

Table 419. DSN_SORT_TABLE description (continued)

Column name	Data type	Description
EXPANSION_REASON	CHAR(2) NOT NULL WITH DEFAULT	<p>This column applies only to statements that reference archive tables or temporal tables. For other statements, this column is blank.</p> <p>Indicates the effect of the CURRENT TEMPORAL BUSINESS_TIME special register, the CURRENT TEMPORAL SYSTEM_TIME special register, and the SYSIBMADM.GET_ARCHIVE built-in global variable. These items are controlled by the BUSTIMESENSITIVE, SYSTIMESENSITIVE, and ARCHIVESENSITIVE bind options.</p> <p>Db2 implicitly adds certain syntax to the query if one of the following conditions are true:</p> <ul style="list-style-type: none"> • The SYSIBMADM.GET_ARCHIVE global variable is set to Y and the ARCHIVESENSITIVE bind option is set to YES • The CURRENT TEMPORAL BUSINESS_TIME special register is not null and the BUSTIMESENSITIVE bind option is set to YES • The CURRENT TEMPORAL SYSTEM_TIME special register is not null and the SYSTIMESENSITIVE bind option is set to YES <p>This column can have one of the following values:</p> <p>'A' The query contains implicit query transformation as a result of the SYSIBMADM.GET_ARCHIVE built-in global variable.</p> <p>'B' The query contains implicit query transformation as a result of the CURRENT TEMPORAL BUSINESS_TIME special register.</p> <p>'S' The query contains implicit query transformation as a result of the CURRENT TEMPORAL SYSTEM_TIME special register.</p> <p>'SB' The query contains implicit query transformation as a result of the CURRENT TEMPORAL SYSTEM_TIME special register and the CURRENT TEMPORAL BUSINESS_TIME special register.</p> <p>blank The query does not contain implicit query transformation.</p>
PER_STMT_ID	BIGINT NOT NULL	<p>The persistent statement identifier for SQL statements in Db2 catalog tables.</p> <p>For example, this column corresponds to the following catalog table columns that identify SQL statements:</p> <ul style="list-style-type: none"> • STMT_ID in SYSIBM.SYSPACKSTMT, for SQL statements in packages. • SDQ_STMT_ID in SYSIBM.SYSDYNQUERY, for stabilized dynamic SQL statements.
AP_PLANID	CHAR(16) FOR BIT DATA	A unique identifier for BIND or PREPARE optimizations for an SQL statement, in the form of an extended timestamp value.

DSN_STATEMENT_CACHE_TABLE

The statement cache table, DSN_STATEMENT_CACHE_TABLE, contains information about the SQL statements in the statement cache, information captured as the results of an EXPLAIN STATEMENT CACHE ALL statement.

PSPI

Recommendation: Do not manually insert data into system-maintained EXPLAIN tables, and use care when deleting obsolete EXPLAIN table data. The data is intended to be manipulated only by the Db2 EXPLAIN function and optimization tools. Certain optimization tools depend on instances of the various EXPLAIN tables. Be careful not to delete data from or drop instances EXPLAIN tables that are created for these tools.

Qualifiers

Your subsystem or data sharing group can contain multiple instances of these tables that are qualified by user ID. These tables are populated with statement cost information when you issue the EXPLAIN statement or bind. They are also populated when you specify EXPLAIN(YES) or EXPLAIN(ONLY) in a BIND or REBIND command. SQL optimization tools might also create EXPLAIN tables that are qualified by a user ID. You can find the SQL statement for creating an instance of these tables in member DSNTESC of the SDSNSAMP library.

Sample CREATE TABLE statement

You can find a sample CREATE TABLE statement for each EXPLAIN table in member DSNTESC of the *prefix.SDSNSAMP* library. You can call the ADMIN_EXPLAIN_MAINT stored procedure to create EXPLAIN tables, upgrade them to the format for the current Db2 release, or complete other maintenance tasks. See [“ADMIN_EXPLAIN_MAINT stored procedure” on page 751](#) for information about using the *action* input parameter to request each of these tasks.

Column descriptions

The following table shows the descriptions of the columns in DSN_STATEMENT_CACHE_TABLE.

Table 420. Descriptions of columns in DSN_STATEMENT_CACHE_TABLE

Column name	Data Type	Description
STMT_ID	INTEGER NOT NULL	The statement ID; this value is the EDM unique token for the statement.
STMT_TOKEN	VARCHAR(240)	The statement token; you provide this value as an identification string.
COLLID	VARCHAR(128) NOT NULL	The collection ID: 'DSNEXPLAINMODEYES' The row originates from an application that specifies YES for the value of the CURRENT EXPLAIN MODE special register. 'DSNEXPLAINMODEEXPLAIN' The row originates from an application that specifies EXPLAIN for the value of the CURRENT EXPLAIN MODE special register.
PROGRAM_NAME	VARCHAR(128) NOT NULL	The name of the package that performed the initial PREPARE for the statement.
INV_DROPALT	CHAR(1) NOT NULL	This column is not used.

Table 420. Descriptions of columns in DSN_STATEMENT_CACHE_TABLE (continued)

Column name	Data Type	Description
INV_REVOKE	CHAR(1) NOT NULL	This column is not used.
INV_LRU	CHAR(1) NOT NULL	This column is not used.
INV_RUNSTATS	CHAR(1) NOT NULL	This column is not used.
CACHED_TS	TIMESTAMP NOT NULL	The timestamp when the statement was stored in the dynamic statement cache. “3” on page 2906
USERS	INTEGER NOT NULL	The number of current users of the statement. This number indicates the users that have prepared or run the statement during their current unit of work. “1” on page 2906 , “3” on page 2906
COPIES	INTEGER NOT NULL	The number of copies of the statement that are owned by all threads in the system. “1” on page 2906 , “3” on page 2906
LINES	INTEGER NOT NULL	The precompiler line number from the initial PREPARE of the statement. “1” on page 2906
PRIMAUTH	VARCHAR(128) NOT NULL	The primary authorization ID that did the initial PREPARE of the statement.
CURSQLID	VARCHAR(128) NOT NULL	The CURRENT SQLID that did the initial PREPARE of the statement.
BIND_QUALIFIER	VARCHAR(128) NOT NULL	The BIND qualifier. For unqualified table names, this is the object qualifier.
BIND_ISO	CHAR(2) NOT NULL	The value of the ISOLATION BIND option that is in effect for this statement. The value will be one of the following values: 'UR' Uncommitted read 'CS' Cursor stability 'RS' Read stability 'RR' Repeatable read
BIND_CDATA	CHAR(1) NOT NULL	The value of the CURRENTDATA BIND option that is in effect for this statement. The value will be one of the following values: 'Y' CURRENTDATA(YES) 'N' CURRENTDATA(NO)

Table 420. Descriptions of columns in DSN_STATEMENT_CACHE_TABLE (continued)

Column name	Data Type	Description
BIND_DYNRL	CHAR(1) NOT NULL	The value of the DYNAMICRULES BIND option that is in effect for this statement. The value will be one of the following values: 'B' DYNAMICRULE(BIND) 'R' DYNAMICRULES(RUN)
BIND_DEGRE	CHAR(1) NOT NULL	The value of the CURRENT DEGREE special register that is in effect for this statement. The value will be one of the following values: 'A' CURRENT DEGREE = ANY '1' CURRENT DEGREE = 1
BIND_SQLRL	CHAR(1) NOT NULL	The value of the CURRENT RULES special register that is in effect for this statement. The value will be one of the following values: 'D' CURRENT RULES = DB2 'S' CURRENT RULES = SQL
BIND_CHOLD	CHAR(1) NOT NULL	The value of the WITH HOLD attribute of the PREPARE for this statement. The value will be one of the following values: 'Y' Initial PREPARE specified WITH HOLD 'N' Initial PREPARE specified WITHOUT HOLD
STAT_TS	TIMESTAMP NOT NULL	Timestamp of the statistics. This is the timestamp when IFCID 318 is started. “2” on page 2906
STAT_EXEC	INTEGER NOT NULL	This column is deprecated. Use STAT_EXECB instead.
STAT_GPAG	INTEGER NOT NULL	This column is deprecated. Use STAT_GPAGB instead. “1” on page 2906
STAT_SYNR	INTEGER NOT NULL	This column is deprecated. Use STAT_SYNRB instead. “1” on page 2906
STAT_WRIT	INTEGER NOT NULL	This column is deprecated. Use STAT_WRITB instead. “1” on page 2906
STAT_EROW	INTEGER NOT NULL	This column is deprecated. Use STAT_EROWB instead. “1” on page 2906
STAT_PROW	INTEGER NOT NULL	This column is deprecated. Use STAT_PROWB instead. “1” on page 2906
STAT_SORT	INTEGER NOT NULL	This column is deprecated. Use STAT_SORTB instead. “1” on page 2906

Table 420. Descriptions of columns in DSN_STATEMENT_CACHE_TABLE (continued)

Column name	Data Type	Description
STAT_INDX	INTEGER NOT NULL	This column is deprecated. Use STAT_INDXB instead.
STAT_RSCN	INTEGER NOT NULL	This column is deprecated. Use STAT_RSCNB instead.
STAT_PGRP	INTEGER NOT NULL	This column is deprecated. Use STAT_PGRPB instead.
STAT_ELAP	FLOAT NOT NULL	The accumulated elapsed time that is used for the statement. “2” on page 2906
STAT_CPU	FLOAT NOT NULL	The accumulated CPU time that is used for the statement. “2” on page 2906
STAT_SUS_SYNIO	FLOAT NOT NULL	The accumulated wait time for synchronous I/O operations for the statement. “2” on page 2906
STAT_SUS_LOCK	FLOAT NOT NULL	The accumulated wait time for lock requests for the statement. “2” on page 2906
STAT_SUS_SWIT	FLOAT NOT NULL	The accumulated wait time for synchronous execution unit switch for the statement. “2” on page 2906
STAT_SUS_GLCK	FLOAT NOT NULL	The accumulated wait time for global parent L-locks for this statement. “2” on page 2906
STAT_SUS_OTHR	FLOAT NOT NULL	The accumulated wait time for read activity that is done by another thread. “2” on page 2906
STAT_SUS_OTHW	FLOAT NOT NULL	The accumulated wait time for write activity done by another thread. “2” on page 2906
STAT_RIDLIMT	INTEGER NOT NULL	This column is deprecated. Use STAT_SORTB instead.
STAT_RIDSTOR	INTEGER NOT NULL	This column is deprecated. Use STAT_SORTB instead.
EXPLAIN_TS	TIMESTAMP NOT NULL	The timestamp for when the statement cache table is populated.
SCHEMA	VARCHAR(128) NOT NULL	The value of the CURRENT SCHEMA special register.
STMT_TEXT	CLOB(2M) NOT NULL	The statement that is being explained.
STMT_ROWID	ROWID NOT NULL GENERATED ALWAYS	The ROWID of the statement.
BIND_RO_TYPE	CHAR(1) NOT NULL WITH DEFAULT	The current specification of the REOPT option for the statement “3” on page 2906 : 'N' REOPT(NONE) or its equivalent '1' REOPT(ONCE) or its equivalent 'A' REOPT(AUTO) or its equivalent 'O' The current plan is deemed optimal and there is no need for REOPT(AUTO)

Table 420. Descriptions of columns in DSN_STATEMENT_CACHE_TABLE (continued)

Column name	Data Type	Description
BIND_RA_TOT	INTEGER NOT NULL WITH DEFAULT	The total number of REBIND commands that have been issued for the dynamic statement because of the REOPT(AUTO) option. “1” on page 2906 , “3” on page 2906
GROUP_MEMBER	VARCHAR(24) NOT NULL WITH DEFAULT	The member name of the Db2 that executed EXPLAIN. The column is blank if the Db2 subsystem was not in a data sharing environment when EXPLAIN was executed.
STAT_EXECB	BIGINT NOT NULL WITH DEFAULT	The number of times this statement has been run. For a statement with a cursor, this is the number of OPENS. “2” on page 2906
STAT_GPAGB	BIGINT NOT NULL WITH DEFAULT	The number of getpage operations that are performed for the statement. “2” on page 2906
STAT_SYNRB	BIGINT NOT NULL WITH DEFAULT	The number of synchronous buffer reads that are performed for the statement. “2” on page 2906
STAT_WRITB	BIGINT NOT NULL WITH DEFAULT	The number of buffer write operations that are performed for the statement. “2” on page 2906
STAT_EROWB	BIGINT NOT NULL WITH DEFAULT	The number of rows that are examined for the statement. “2” on page 2906
STAT_PROWB	BIGINT NOT NULL WITH DEFAULT	The number of rows that are processed for the statement. “2” on page 2906
STAT_SORTB	BIGINT NOT NULL WITH DEFAULT	The number of sorts that are performed for the statement. “2” on page 2906
STAT_INDXB	BIGINT NOT NULL WITH DEFAULT	The number of index scans that are performed for the statement. “2” on page 2906
STAT_RSCNB	BIGINT NOT NULL WITH DEFAULT	The number of table space scans that are performed for the statement. “2” on page 2906
STAT_PGRPB	BIGINT NOT NULL WITH DEFAULT	The number of parallel groups that are created for the statement. “2” on page 2906
STAT_RIDLIMTB	BIGINT NOT NULL WITH DEFAULT	The number of times a RID list was not used because the number of RIDs would have exceeded Db2 limits. “2” on page 2906
STAT_RIDSTORB	BIGINT NOT NULL WITH DEFAULT	The number of times a RID list was not used because there is not enough storage available to hold the list of RIDs. “2” on page 2906

Table 420. Descriptions of columns in DSN_STATEMENT_CACHE_TABLE (continued)

Column name	Data Type	Description
LITERAL_REPL	CHAR(1) NOT NULL WITH DEFAULT	Identifies cached statements where the literal values are replaced by the '&' symbol:“3” on page 2906 'R' The statement is prepared with CONCENTRATE STATEMENTS WITH LITERALS behavior and the literal constants in the statement have been replaced with '&' . 'D' This statement is a duplicate statement instance with different literal reusability criteria. blank Literal values are not replaced.
STAT_SUS_LATCH	FLOAT NOT NULL WITH DEFAULT	The accumulated wait time for latch requests for the statement.
STAT_SUS_PLATCH	FLOAT NOT NULL WITH DEFAULT	The accumulated wait time for page latch requests for the statement.
STAT_SUS_DRAIN	FLOAT NOT NULL WITH DEFAULT	The accumulated wait time for drain lock requests for the statement.
STAT_SUS_CLAIM	FLOAT NOT NULL WITH DEFAULT	The accumulated wait time for claim count requests for the statement.
STAT_SUS_LOG	FLOAT NOT NULL WITH DEFAULT	The accumulated wait time for log writer requests for the statement.

Table 420. Descriptions of columns in DSN_STATEMENT_CACHE_TABLE (continued)

Column name	Data Type	Description
EXPANSION_REASON	CHAR(2) NOT NULL WITH DEFAULT	<p>This column applies only to statements that reference archive tables or temporal tables. For other statements, this column is blank.</p> <p>Indicates the effect of the CURRENT TEMPORAL BUSINESS_TIME special register, the CURRENT TEMPORAL SYSTEM_TIME special register, and the SYSIBMADM.GET_ARCHIVE built-in global variable. These items are controlled by the BUSTIMESENSITIVE, SYSTIMESENSITIVE, and ARCHIVESENSITIVE bind options.</p> <p>Db2 implicitly adds certain syntax to the query if one of the following conditions are true:</p> <ul style="list-style-type: none"> • The SYSIBMADM.GET_ARCHIVE global variable is set to Y and the ARCHIVESENSITIVE bind option is set to YES • The CURRENT TEMPORAL BUSINESS_TIME special register is not null and the BUSTIMESENSITIVE bind option is set to YES • The CURRENT TEMPORAL SYSTEM_TIME special register is not null and the SYSTIMESENSITIVE bind option is set to YES <p>This column can have one of the following values:</p> <p>'A' The query contains implicit query transformation as a result of the SYSIBMADM.GET_ARCHIVE built-in global variable.</p> <p>'B' The query contains implicit query transformation as a result of the CURRENT TEMPORAL BUSINESS_TIME special register.</p> <p>'S' The query contains implicit query transformation as a result of the CURRENT TEMPORAL SYSTEM_TIME special register.</p> <p>'SB' The query contains implicit query transformation as a result of the CURRENT TEMPORAL SYSTEM_TIME special register and the CURRENT TEMPORAL BUSINESS_TIME special register.</p> <p>blank The query does not contain implicit query transformation.</p>

Table 420. Descriptions of columns in DSN_STATEMENT_CACHE_TABLE (continued)

Column name	Data Type	Description
ACCELERATED	CHAR(10)	<p>Identifies whether a cached dynamic statement was prepared for acceleration to an accelerator server. Possible values are:</p> <p>'NO'</p> <p>The cached statement was not prepared for acceleration. This is the default value.</p> <p>This value also applies to cached statements under the following conditions:</p> <ul style="list-style-type: none">• The query acceleration behavior was not specified or was explicitly set to NONE when the dynamic statement was prepared.• A query acceleration behavior other than ALL was specified when the dynamic statement was prepared. Db2 did not prepare the statement for acceleration because it did not qualify for acceleration based on the query acceleration behavior that was specified. <p>'YES'</p> <p>The cached statement was prepared for acceleration to an accelerator server based on the query acceleration behavior that was specified. If query acceleration behavior is specified when a dynamic statement is prepared, Db2 can consider this cache entry for a possible cache match during the prepare operation of the dynamic statement. If query acceleration behavior is not specified, or is explicitly set to NONE when the statement is prepared, Db2 does not consider this cache entry for a cache match during the prepare operation.</p> <p>'NEVER'</p> <p>The cached statement was not prepared for acceleration to an accelerated server, because the statement can never be accelerated.</p> <ul style="list-style-type: none">• If the query acceleration behavior is set to ENABLE, ENABLE WITH FAILBACK, or ELIGIBLE for the prepare of the statement, Db2 considers this cache entry first as a possible cache match during the prepare operation. This action verifies whether the statement was cached previously as one that can never be accelerated. <p>(Continued in the following row.)</p>

Table 420. Descriptions of columns in DSN_STATEMENT_CACHE_TABLE (continued)

Column name	Data Type	Description
ACCELERATED (continued)		(Continued from the previous row.) 'NEVER' (continued) <ul style="list-style-type: none"> • If the query acceleration behavior is set to ALL for the prepare of the statement, Db2 does not consider this cache entry as a possible cache match during the prepare operation. • If the query acceleration behavior is not specified, or is explicitly set to NONE for the prepare of the statement, Db2 does not consider this cache entry as a possible cache match during the prepare operation. 'ACCEL_ONLY' The cached statement was prepared for acceleration to an accelerator. The statement references at least one accelerator-only table and can only be prepared to execute in the accelerator server. If query acceleration behavior is specified when a dynamic statement is prepared, Db2 can consider this cache entry for a possible cache match during the prepare operation of the dynamic statement. If query acceleration behavior is not specified, or is explicitly set to NONE when the statement is prepared, Db2 does not consider this cache entry for a cache match during the prepare operation. Query acceleration behavior is specified by either the QUERY_ACCELERATION subsystem parameter, the QUERYACCELERATION bind option, or the CURRENT QUERY ACCELERATION special register, and depends on their order of precedence. The order of precedence (lowest to highest) is: <ul style="list-style-type: none"> • The QUERY_ACCELERATION subsystem parameter • The QUERYACCELERATION bind option, if specified • An explicit SET CURRENT QUERY ACCELERATION statement
STAT_ACC_ELAP	BIGINT	The accumulated elapsed time for the accelerator.
STAT_ACC_CPU	BIGINT	The accumulated CPU time for the accelerator.
STAT_ACC_ROW	BIGINT	The accumulated number of rows that are returned from the accelerator.
STAT_ACC_BYTE	BIGINT	The accumulated number of bytes that are returned from the accelerator.
STAT_ACC_1ROW	BIGINT	The time waited for the first row of the query result to be available from the accelerator.
STAT_ACC_DB2	BIGINT	The total time the accelerator waited for Db2 to request query results.
STAT_ACC_EXEC	BIGINT	The accumulated execution time for the accelerator.

Table 420. Descriptions of columns in DSN_STATEMENT_CACHE_TABLE (continued)

Column name	Data Type	Description
STAT_ACC_WAIT	BIGINT	The accumulated queue wait time for the accelerator.
ACCEL_OFFLOAD_ELIGIBLE	CHAR(1)	'NO' The statement is not eligible for acceleration. This is the default value. 'YES' The statement is a candidate for acceleration when an accelerator server is available to the Db2 subsystem.
ACCELERATOR_NAME	VARCHAR(128)	The concatenated name of the accelerator server that processed the query.
PER_STMT_ID	BIGINT NOT NULL	The statement identifier of the stabilized dynamic SQL statement. This value is set if this entry was stabilized to or loaded from the SYSIBM.SYSDNQRY catalog table
STBLGRP	VARCHAR(128) NOT NULL	The stabilization group name specified in a START DYNQRY command. This value is set if this entry was stabilized to or loaded from the SYSIBM.SYSDNQRY catalog table.
QUERY_HASH	CHAR(16) NOT NULL FOR BIT DATA	The hash key generated by the statement text.
QUERY_HASH_VERSION	INTEGER NOT NULL	The version of QUERY_HASH.
STABILIZED	CHAR(1) NOT NULL	Indicates whether the statement was stabilized.
APPLCOMPAT	VARCHAR(10) NOT NULL	The application compatibility level of a dynamic SQL statement.
CNO	BIGINT NOT NULL	The command number for the dynamic query capture monitor if applicable. Otherwise 0.
STAT_SUS_CHILDLLOCK	FLOAT NOT NULL WITH DEFAULT	The accumulated wait time for child L-locks for the statement.
STAT_SUS_OTHERLLOCK	FLOAT NOT NULL WITH DEFAULT	The accumulated wait time for other L-locks for the statement.
STAT_SUS_PAGESETPLOCK	FLOAT NOT NULL WITH DEFAULT	The accumulated wait time for global pageset or partition L-locks for the statement.
STAT_SUS_PAGEPLOCK	FLOAT NOT NULL WITH DEFAULT	The accumulated wait time for page P-locks for the statement.
STAT_SUS_OTHERPLOCK	FLOAT NOT NULL WITH DEFAULT	The accumulated wait time for other P-locks for the statement.
STAT_SUS_PIPE	FLOAT NOT NULL WITH DEFAULT	The accumulated wait time for pipe requests for the statement.
STAT_SUS_PQSYNC	FLOAT NOT NULL WITH DEFAULT	The accumulated waittime for parallel query waits for the statement.
STAT_ACC_TWDP	BIGINT	The accumulated wait time for the accelerator delay protocol.
STAT_ACC_NWDP	BIGINT	The accumulated number of statements for which the wait time for the accelerator delay protocol has expired.

Table 420. Descriptions of columns in DSN_STATEMENT_CACHE_TABLE (continued)

Column name	Data Type	Description
STMT_HASHID2	CHAR(8) FOR BIT DATA	Used to identify an SQL statement. Based on normalized SQL statement text. <ul style="list-style-type: none"> Includes certain BIND options for static SQL, and PREPARE attributes for dynamic SQL. Includes COLLID and PACKAGE name for static SQL. Excludes COLLID and PACKAGE name for dynamic SQL. Excludes VERSION name for static SQL.
STMT_HASH2VER	INTEGER	Used to identify the version of the hash algorithm that is used to compute the STMT_HASHID2 value.
AP_PLANID	CHAR(16) FOR BIT DATA	A unique identifier for BIND or PREPARE optimizations for an SQL statement, in the form of an extended timestamp value.
AP_PLANHASH	CHAR(16) FOR BIT DATA	Used to identifier an access path based on selected columns of the PLAN_TABLE that contribute to the access path. This value excludes columns that do not affect the access path, such as APPLNAME, PROGNAME, VERSION, and others.
AP_PLANHASHVER	INTEGER	Used to identify the version of the hash algorithm that is used to compute the AP_PLANHASH value.
CONNECTION_TYPE	CHAR(8)	Connection type which did the PREPARE or BIND for the statement.
CLIENT_USERID	VARCHAR(128)	The client user ID name information.
CLIENT_APPLNAME	VARCHAR(255)	The client application name information.
CLIENT_WRKSTNNAME	VARCHAR(255)	The client workstation name information.

Notes:

1. If the specified value exceeds 2147483647, the column contains the value 2147483647.
2. Statistics are cumulative, across executions of the same statement, and across threads, if the value of COLLID is DSNDYNAMICSQLCACHE. If the value of COLLID is DSNEXPLAINMODEYES, the values are for a single run of the statement only. If the value of COLLID is DSNEXPLAINMODE EXPLAIN, the values of all statistics columns are 0.
3. The column is not applicable when the value of the COLLID column is 'DSNEXPLAINMODEYES' or 'DSNEXPLAINMODEEXPLAIN'

PSPI

DSN_STATEMNT_TABLE

The statement table, DSN_STATEMNT_TABLE, contains information about the estimated cost of specified SQL statements.

PSPI

Recommendation: Do not manually insert data into system-maintained EXPLAIN tables, and use care when deleting obsolete EXPLAIN table data. The data is intended to be manipulated only by the Db2 EXPLAIN function and optimization tools. Certain optimization tools depend on instances of the various

EXPLAIN tables. Be careful not to delete data from or drop instances EXPLAIN tables that are created for these tools.

Qualifiers

Your subsystem or data sharing group can contain multiple instances of these tables that are qualified by user ID. These tables are populated with statement cost information when you issue the EXPLAIN statement or bind. They are also populated when you specify EXPLAIN(YES) or EXPLAIN(ONLY) in a BIND or REBIND command. SQL optimization tools might also create EXPLAIN tables that are qualified by a user ID. You can find the SQL statement for creating an instance of these tables in member DSNTESC of the SDSNSAMP library.

Sample CREATE TABLE statement

You can find a sample CREATE TABLE statement for each EXPLAIN table in member DSNTESC of the *prefix.SDSNSAMP* library. You can call the ADMIN_EXPLAIN_MAINT stored procedure to create EXPLAIN tables, upgrade them to the format for the current Db2 release, or complete other maintenance tasks. See “ADMIN_EXPLAIN_MAINT stored procedure” on page 751 for information about using the *action* input parameter to request each of these tasks.

Column descriptions

The following table describes the content of each column in STATEMNT_TABLE.

Table 421. Descriptions of columns in DSN_STATEMNT_TABLE

Column name	Data type	Description
QUERYNO	INTEGER NOT NULL WITH DEFAULT	<p>A number that identifies the statement that is being explained. The origin of the value depends on the context of the row:</p> <p>For rows produced by EXPLAIN statements The number specified in the QUERYNO clause, which is an optional part of the SELECT, INSERT, UPDATE, MERGE, and DELETE statement syntax.</p> <p>For rows not produced by EXPLAIN statements Db2 assigns a number that is based on the line number of the SQL statement in the source program.</p> <p>When the values of QUERYNO are based on the statement number in the source program, values that exceed 32767 are reported as 0. However, in certain rare cases, the value is not guaranteed to be unique.</p> <p>When the SQL statement is embedded in a compiled SQL function, native SQL procedure, or advanced trigger, if the QUERYNO clause is specified, its value is used by Db2. Otherwise Db2 assigns a number based on the line number of the SQL statement in the compiled SQL function, native SQL procedure, or advanced trigger.</p>
APPLNAME	VARCHAR(24) NOT NULL WITH DEFAULT	<p>The name of the application plan for the row. Applies only to embedded EXPLAIN statements that are executed from a plan or to statements that are explained when binding a plan. A blank indicates that the column is not applicable.</p> <p>When the SQL statement is embedded in a compiled SQL function, native SQL procedure, or advanced trigger, this column is not used, and is blank.</p>

Table 421. Descriptions of columns in DSN_STATEMNT_TABLE (continued)

Column name	Data type	Description
PROGNAME	VARCHAR(128) NOT NULL WITH DEFAULT	<p>The name of the program or package containing the statement being explained. Applies only to embedded EXPLAIN statements and to statements explained as the result of binding a plan or package. A blank indicates that the column is not applicable.</p> <p>When the SQL statement is embedded in a compiled SQL function or native SQL procedure, this column indicates the specific name of the compiled SQL function or native SQL procedure. When the SQL statement is embedded in an advanced trigger, this column contains the name of the trigger.</p>
COLLID	VARCHAR(128) NOT NULL WITH DEFAULT	<p>The collection ID:</p> <p>'DSNDYNAMICSQLCACHE' The row originates from the dynamic statement cache.</p> <p>'DSNEXPLAINMODEYES' The row originates from an application that specifies YES for the value of the CURRENT EXPLAIN MODE special register.</p> <p>'DSNEXPLAINMODEEXPLAIN' The row originates from an application that specifies EXPLAIN for the value of the CURRENT EXPLAIN MODE special register.</p> <p>When the SQL statement is embedded in a compiled SQL function, native SQL procedure, or advanced trigger, this column indicates the schema name of the compiled SQL function, native SQL procedure, or advanced trigger.</p>
GROUP_MEMBER	VARCHAR(24) NOT NULL WITH DEFAULT	The member name of the Db2 that executed EXPLAIN. The column is blank if the Db2 subsystem was not in a data sharing environment when EXPLAIN was executed.
EXPLAIN_TIME	TIMESTAMP NOT NULL WITH DEFAULT	<p>The time when the EXPLAIN information was captured:</p> <p>All cached statements When the statement entered the cache, in the form of a full-precision timestamp value.</p> <p>Non-cached static statements When the statement was bound, in the form of a full precision timestamp value.</p> <p>Non-cached dynamic statements When EXPLAIN was executed, in the form of a value equivalent to a CHAR(16) representation of the time appended by 4 zeros.</p>

Table 421. Descriptions of columns in DSN_STATEMNT_TABLE (continued)

Column name	Data type	Description
STMT_TYPE	CHAR(6) NOT NULL WITH DEFAULT	<p>The type of statement being explained. Possible values are:</p> <p>SELECT SELECT</p> <p>INSERT INSERT</p> <p>UPDATE UPDATE</p> <p>MERGE MERGE</p> <p>DELETE DELETE</p> <p>TRUNCA TRUNCATE</p> <p>SELUPD SELECT with FOR UPDATE OF</p> <p>DELCUR DELETE WHERE CURRENT OF CURSOR</p> <p>UPDCUR UPDATE WHERE CURRENT OF CURSOR</p> <p>PRUNED A query that always returns 0 rows.</p> <p>blank None of the above statement types.</p>
COST_CATEGORY	CHAR(1) NOT NULL WITH DEFAULT	<p>Indicates if Db2 was forced to use default values when making its estimates. Possible values:</p> <p>A Indicates that Db2 had enough information to make a cost estimate without using default values.</p> <p>B Indicates that some condition exists for which Db2 was forced to use default values. See the values in REASON to determine why Db2 was unable to put this estimate in cost category A.</p>
PROCMS	INTEGER NOT NULL WITH DEFAULT	<p>The estimated processor cost, in milliseconds, for the SQL statement. The estimate is rounded up to the next integer value. The maximum value for this cost is 2147483647 milliseconds, which is equivalent to approximately 24.8 days. If the estimated value exceeds this maximum, the maximum value is reported. If an accelerator is used, the difference is reflected in this value.</p>
PROCSU	INTEGER NOT NULL WITH DEFAULT	<p>The estimated processor cost, in service units, for the SQL statement. The estimate is rounded up to the next integer value. The maximum value for this cost is 2147483647 service units. If the estimated value exceeds this maximum, the maximum value is reported. If an accelerator is used, this value represents the estimated cost including any impact of acceleration.</p>

Table 421. Descriptions of columns in DSN_STATEMNT_TABLE (continued)

Column name	Data type	Description
REASON	VARCHAR(254) WITH DEFAULT	<p>A string that indicates the reasons for putting an estimate into cost category B.</p> <p>ACCELMODEL ELIGIBLE The query is eligible for acceleration.</p> <p>ACCELMODEL NOT ELIGIBLE The query is not eligible for acceleration.</p> <p>HAVING CLAUSE A subselect in the SQL statement contains a HAVING clause.</p> <p>HOST VARIABLES The statement uses host variables, parameter markers, or special registers.</p> <p>OPTIMIZATION HINTS An statement-level access path, or PLAN_TABLE access path hint is applied to the statement, or APREUSE(ERROR/WARN) is applied for the package.</p> <p>PROFILEID value When profile monitoring is used for the statement, the value of the PROFILEID column in SYSIBM.DSN_PROFILE_TABLE.</p> <p>REFERENTIAL CONSTRAINTS Referential constraints of the type CASCADE or SET NULL exist on the target table of a DELETE statement.</p> <p>TABLE CARDINALITY The cardinality statistics are missing for one or more of the tables that are used in the statement, or the statement used materialized views or table expressions.</p> <p>TRIGGERS Triggers are defined on the target table of an insert, update, or delete operation.</p> <p>UDF The statement uses user-defined functions.</p>
STMT_ENCODE	CHAR(1) WITH DEFAULT	<p>Encoding scheme of the statement. If the statement represents a single CCSID set, the possible values are:</p> <p>A ASCII</p> <p>E EBCDIC</p> <p>U Unicode</p> <p>If the statement has multiple CCSID sets, the value is M.</p>
TOTAL_COST	FLOAT NOT NULL WITH DEFAULT	<p>The overall estimated cost of the statement. If an accelerator is used, the benefit is reflected in this value. . Use this value for reference purposes only. Db2 does not always choose the access path that has the lowest TOTAL_COST value. Db2 also uses other factors during access path selection, such as the reliability of the filter factor estimates.</p>

Table 421. Descriptions of columns in DSN_STATEMNT_TABLE (continued)

Column name	Data type	Description
SECTNOI	INTEGER NOT NULL WITH DEFAULT	The section number of the statement. The value is taken from the same column in SYSPACKSTMT or SYSSTMT tables and can be used to join tables to reconstruct the access path for the statement. This column is applicable only for static statements. The default value of -1 indicates EXPLAIN information that was captured in DB2 9 or earlier.
VERSION	VARCHAR(122) NOT NULL WITH DEFAULT	<p>The version identifier for the package. Applies only to an embedded EXPLAIN statement executed from a package or to a statement that is explained when binding a package.</p> <p>If the value is not blank, the value is the same as the VERSION value for the package that was used to create this EXPLAIN table row.</p> <p>The value is blank for a statement in:</p> <ul style="list-style-type: none"> • A package for a basic trigger (TYPE='T') • A package for an application that was precompiled without SQL processing option VERSION • A package that was precompiled with an empty string for the VERSION value (TYPE=blank) <p>When the SQL statement is embedded in a compiled SQL function or native SQL procedure, this column indicates the version identifier of the function or procedure. When the SQL statement is embedded in an advanced trigger body, this column is not used and will be blank.</p>

Table 421. Descriptions of columns in DSN_STATEMNT_TABLE (continued)

Column name	Data type	Description
EXPANSION_REASON	CHAR(2) NOT NULL WITH DEFAULT	<p>This column applies only to statements that reference archive tables or temporal tables. For other statements, this column is blank.</p> <p>Indicates the effect of the CURRENT TEMPORAL BUSINESS_TIME special register, the CURRENT TEMPORAL SYSTEM_TIME special register, and the SYSIBMADM.GET_ARCHIVE built-in global variable. These items are controlled by the BUSTIMESENSITIVE, SYSTIMESENSITIVE, and ARCHIVESENSITIVE bind options.</p> <p>Db2 implicitly adds certain syntax to the query if one of the following conditions are true:</p> <ul style="list-style-type: none"> • The SYSIBMADM.GET_ARCHIVE global variable is set to Y and the ARCHIVESENSITIVE bind option is set to YES • The CURRENT TEMPORAL BUSINESS_TIME special register is not null and the BUSTIMESENSITIVE bind option is set to YES • The CURRENT TEMPORAL SYSTEM_TIME special register is not null and the SYSTIMESENSITIVE bind option is set to YES <p>This column can have one of the following values:</p> <p>'A' The query contains implicit query transformation as a result of the SYSIBMADM.GET_ARCHIVE built-in global variable.</p> <p>'B' The query contains implicit query transformation as a result of the CURRENT TEMPORAL BUSINESS_TIME special register.</p> <p>'S' The query contains implicit query transformation as a result of the CURRENT TEMPORAL SYSTEM_TIME special register.</p> <p>'SB' The query contains implicit query transformation as a result of the CURRENT TEMPORAL SYSTEM_TIME special register and the CURRENT TEMPORAL BUSINESS_TIME special register.</p> <p>blank The query does not contain implicit query transformation.</p>

Table 421. Descriptions of columns in DSN_STATEMNT_TABLE (continued)

Column name	Data type	Description
APCOMPARE_STATUS	CHAR(1) NOT NULL WITH DEFAULT	<p>The status of the access path comparison operation for the APCOMPARE option of a BIND or REBIND command.</p> <p>'S' Access path comparison succeeded, and the structure of the new access path matches the previous access path.</p> <p>'F' The structure of the new access path does not match the previous access path, or the access path comparison operation failed.</p> <p>'N' No match was found.</p> <p>blank This is the default value. APCOMPARE is not used, APCOMPARE was used prior to Db2 12, or APCOMPARE was used before this column was added to the table.</p>
APREUSE_STATUS	CHAR(1) NOT NULL WITH DEFAULT	<p>The status of the access path reuse operation for the APREUSE option of a BIND or REBIND command.</p> <p>'S' Access path reuse succeeded.</p> <p>'F' Access path reuse failed.</p> <p>'N' No match was found.</p> <p>blank This is the default value. APREUSE was not used, APREUSE was used prior to Db2 12, or APREUSE was used before this column was added to the table.</p>
APREUSE_VERSION	VARCHAR(122) NOT NULL WITH DEFAULT	<p>The version identifier for the package. The value is the bind version of the package whose access path is reused. The default value blank is used when APREUSE_STATUS is blank.</p>
APREUSE_COPYID	INTEGER NOT NULL WITH DEFAULT	<p>The copy number of identifier for the package. The value is the copy number of the package whose access plan is being taken to be reused. The default value -1 blank is used when APREUSE_STATUS is blank.</p>

Table 421. Descriptions of columns in DSN_STATEMNT_TABLE (continued)

Column name	Data type	Description
EXPLAIN_TYPE	CHAR(1)	<p>The type of action that created the row:</p> <p>'A' Automatic bind</p> <p>'B' BIND command</p> <p>'C' EXPLAIN STATEMENT CACHE statement</p> <p>'D' Dynamic EXPLAIN statement</p> <p>'R' REBIND command</p> <p>'S' EXPLAIN STABILIZED DYNAMIC QUERY statement.</p> <p>blank The row existed before this column was added to the table. This is the default value.</p>
PER_STMT_ID	BIGINT NOT NULL	<p>The persistent statement identifier for SQL statements in Db2 catalog tables.</p> <p>For example, this column corresponds to the following catalog table columns that identify SQL statements:</p> <ul style="list-style-type: none"> • STMT_ID in SYSIBM.SYSPACKSTMT, for SQL statements in packages. • SDQ_STMT_ID in SYSIBM.SYSDYNQUERY, for stabilized dynamic SQL statements.
QUERY_HASH	CHAR(16) NOT NULL FOR BIT DATA	<p>The hash key that is generated by the statement text. This value is not unique for each statement. Other columns for the collection ID, package name, section number, and query number can be used with the hash key for uniqueness.</p>
FUNCTION_LVL	VARCHAR(10) NOT NULL WITH DEFAULT	<p>The function level of the Db2 subsystem when the access path was selected for the statement.</p>
STMT_HASHID2	CHAR(8) FOR BIT DATA	<p>Used to identify an SQL statement. Based on normalized SQL statement text.</p> <ul style="list-style-type: none"> • Includes certain BIND options for static SQL, and PREPARE attributes for dynamic SQL. • Includes COLLID and PACKAGE name for static SQL. • Excludes COLLID and PACKAGE name for dynamic SQL. • Excludes VERSION name for static SQL.
STMT_HASH2VER	INTEGER	<p>Used to identify the version of the hash algorithm that is used to compute the STMT_HASHID2 value.</p>
AP_PLANID	CHAR(16) FOR BIT DATA	<p>A unique identifier for BIND or PREPARE optimizations for an SQL statement, in the form of an extended timestamp value.</p>

Table 421. Descriptions of columns in DSN_STATEMNT_TABLE (continued)

Column name	Data type	Description
AP_PLANHASH	CHAR(16) FOR BIT DATA	Used to identify an access path. Based on selected columns of the PLAN_TABLE which contribute to the access path. Excludes cols that don't affect the access path, such as APPLNAME, PROGRAMNAME, VERSION, etc.
AP_PLANHASHVER	INTEGER	Used to identify the version of the hash algorithm that is used to compute the AP_PLANHASH value.
AP_SERVICE_DATA	VARCHAR(512) FOR BIT DATA	Used to save optimizer-sensitive environment variables at the time of optimization.
CONNECTION_TYPE	CHAR(8)	Connection type which did the PREPARE or BIND for the statement.
CLIENT_USERID	VARCHAR(128)	The client user ID name information.
CLIENT_APPLNAME	VARCHAR(255)	The client application name information.
CLIENT_WRKSTNNAME	VARCHAR(255)	The client workstation name information.

PSPI

Related information

[IBM Db2 Analytics Accelerator for z/OS documentation](#)

DSN_STAT_FEEDBACK

The DSN_STAT_FEEDBACK table contains recommendations for capturing missing or conflicting statistics that are defined during EXPLAIN.

Collecting these statistics by the RUNSTATS utility might improve the performance of the query.

PSPI The values in this table are updated only at EXPLAIN time, and are not modified by the RUNSTATS utility.

Information is captured in this table only for EXPLAIN operations that use the access path selection process. The access path selection process is not used when you issue an EXPLAIN statement with the STMTCACHE or PACKAGE options.

Recommendation: Do not manually insert data into system-maintained EXPLAIN tables, and use care when deleting obsolete EXPLAIN table data. The data is intended to be manipulated only by the Db2 EXPLAIN function and optimization tools. Certain optimization tools depend on instances of the various EXPLAIN tables. Be careful not to delete data from or drop instances EXPLAIN tables that are created for these tools.

Qualifiers

Your subsystem or data sharing group can contain multiple instances of these tables that are qualified by user ID. These tables are populated with statement cost information when you issue the EXPLAIN statement or bind. They are also populated when you specify EXPLAIN(YES) or EXPLAIN(ONLY) in a BIND or REBIND command. SQL optimization tools might also create EXPLAIN tables that are qualified by a user ID. You can find the SQL statement for creating an instance of these tables in member DSNTESC of the SDSNSAMP library.

Sample CREATE TABLE statement

You can find a sample CREATE TABLE statement for each EXPLAIN table in member DSNTESC of the *prefix*.SDSNSAMP library. You can call the ADMIN_EXPLAIN_MAINT stored procedure to create EXPLAIN

tables, upgrade them to the format for the current Db2 release, or complete other maintenance tasks. See “ADMIN_EXPLAIN_MAINT stored procedure” on page 751 for information about using the *action* input parameter to request each of these tasks.

Column descriptions

The following table contains descriptions of the columns in the DSN_STAT_FEEDBACK table.

Table 422. Descriptions of columns in the DSN_STAT_FEEDBACK table

Column name	Data Type	Descriptions
QUERYNO	INTEGER NOT NULL	<p>A number that identifies the statement that is being explained. The origin of the value depends on the context of the row:</p> <p>For rows produced by EXPLAIN statements The number specified in the QUERYNO clause, which is an optional part of the SELECT, INSERT, UPDATE, MERGE, and DELETE statement syntax.</p> <p>For rows not produced by EXPLAIN statements Db2 assigns a number that is based on the line number of the SQL statement in the source program.</p> <p>When the values of QUERYNO are based on the statement number in the source program, values that exceed 32767 are reported as 0. However, in certain rare cases, the value is not guaranteed to be unique.</p> <p>When the SQL statement is embedded in a compiled SQL function, native SQL procedure, or advanced trigger, if the QUERYNO clause is specified, its value is used by Db2. Otherwise Db2 assigns a number based on the line number of the SQL statement in the compiled SQL function, native SQL procedure, or advanced trigger.</p>
APPLNAME	VARCHAR(24) NOT NULL	<p>The name of the application plan for the row. Applies only to embedded EXPLAIN statements that are executed from a plan or to statements that are explained when binding a plan. A blank indicates that the column is not applicable.</p> <p>When the SQL statement is embedded in a compiled SQL function, native SQL procedure, or advanced trigger, this column is not used, and is blank.</p>
PROGNAME	VARCHAR(128) NOT NULL	<p>The name of the program or package containing the statement being explained. Applies only to embedded EXPLAIN statements and to statements explained as the result of binding a plan or package. A blank indicates that the column is not applicable.</p> <p>When the SQL statement is embedded in a compiled SQL function or native SQL procedure, this column indicates the specific name of the compiled SQL function or native SQL procedure. When the SQL statement is embedded in an advanced trigger, this column contains the name of the trigger.</p>

Table 422. Descriptions of columns in the DSN_STAT_FEEDBACK table (continued)

Column name	Data Type	Descriptions
COLLID	VARCHAR(128) NOT NULL WITH DEFAULT	<p>The collection ID:</p> <p>'DSNEXPLAINMODEYES' The row originates from an application that specifies YES for the value of the CURRENT EXPLAIN MODE special register.</p> <p>'DSNEXPLAINMODEEXPLAIN' The row originates from an application that specifies EXPLAIN for the value of the CURRENT EXPLAIN MODE special register.</p> <p>When the SQL statement is embedded in a compiled SQL function, native SQL procedure, or advanced trigger, this column indicates the schema name of the compiled SQL function, native SQL procedure, or advanced trigger.</p>
GROUP_MEMBER	VARCHAR(24) NOT NULL	The member name of the Db2 that executed EXPLAIN. The column is blank if the Db2 subsystem was not in a data sharing environment when EXPLAIN was executed.
EXPLAIN_TIME	TIMESTAMP NOT NULL	<p>The time when the EXPLAIN information was captured:</p> <p>All cached statements When the statement entered the cache, in the form of a full-precision timestamp value.</p> <p>Non-cached static statements When the statement was bound, in the form of a full precision timestamp value.</p> <p>Non-cached dynamic statements When EXPLAIN was executed, in the form of a value equivalent to a CHAR(16) representation of the time appended by 4 zeros.</p>
SECTNOI	INTEGER NOT NULL WITH DEFAULT WITH DEFAULT	The section number of the statement. The value is taken from the same column in SYSPACKSTMT or SYSSTMT tables and can be used to join tables to reconstruct the access path for the statement. This column is applicable only for static statements. The default value of -1 indicates EXPLAIN information that was captured in DB2 9 or earlier.

Table 422. Descriptions of columns in the DSN_STAT_FEEDBACK table (continued)

Column name	Data Type	Descriptions
VERSION	VARCHAR(122) NOT NULL WITH DEFAULT	<p>The version identifier for the package. Applies only to an embedded EXPLAIN statement executed from a package or to a statement that is explained when binding a package.</p> <p>If the value is not blank, the value is the same as the VERSION value for the package that was used to create this EXPLAIN table row.</p> <p>The value is blank for a statement in:</p> <ul style="list-style-type: none"> • A package for a basic trigger (TYPE='T') • A package for an application that was precompiled without SQL processing option VERSION • A package that was precompiled with an empty string for the VERSION value (TYPE=blank) <p>When the SQL statement is embedded in a compiled SQL function or native SQL procedure, this column indicates the version identifier of the function or procedure. When the SQL statement is embedded in an advanced trigger body, this column is not used and will be blank.</p>
TBCREATOR	VARCHAR(128) NOT NULL	The creator of the table.
TBNAME	VARCHAR(128) NOT NULL	The name of the table.
IXCREATOR	VARCHAR(128) NOT NULL	The creator of the index.
IXNAME	VARCHAR(128) NOT NULL	The name of the index.
COLNAME	VARCHAR(128) NOT NULL	The name of the column.
NUMCOLUMNS	SMALLINT NOT NULL	The number of columns in the column group.
COLGROUPCOLNO	VARCHAR(254) NOT NULL FOR BIT DATA	A hex representation that identifies the set of columns associated with the statistics. If the statistics are only associated with a single column, the field contains a zero length. Otherwise, the field is an array of SMALLINT column numbers with a dimension equal to the value in NUMCOLUMNS.

Table 422. Descriptions of columns in the DSN_STAT_FEEDBACK table (continued)

Column name	Data Type	Descriptions
TYPE	CHAR(1) NOT NULL	<p>The type of statistic to collect:</p> <p>'C' Cardinality.</p> <p>'F' Frequency.</p> <p>'H' Histogram.</p> <p>'I' Index.</p> <p>'T' Table.</p>
DBNAME	VARCHAR(24) NOT NULL	The name of the database.
TSNAME	VARCHAR(24) NOT NULL	The name of the table space.
REASON	CHAR(8) NOT NULL	<p>The reason for the statistics collection recommendation:</p> <p>'BASIC' A basic statistic value for a column, table, or index is missing. No statistics were collected for the identified object.</p> <p>'CONFLICT' Another statistic contains a value that conflicts with the value of this statistic. Such conflicts usually occur because statistics were collected for related objects at different times.</p> <p>'COMPFFIX' Multi-column cardinality statistics are needed for an index compound filter factor.</p> <p>'DEFAULT' A predicate references a value that is probably a default value, which indicates that data might be skewed.</p> <p>'KEYCARD' The cardinalities of index key columns are missing.</p> <p>'LOWCARD' The cardinality of the column is a low value, which indicates that data might be skewed.</p> <p>'NULLABLE' Distribution statistics are not available for a nullable column, which indicates that data might be skewed.</p> <p>'RANGEPRD' Histogram statistics are not available for a range predicate.</p> <p>'PARALLEL' Parallelism might be improved by uniform partitioning of key ranges.</p> <p>'STALE' A statistic appears likely to be out of sync with other statistics, based on comparison of the time that it was collected to statistics collection times for related objects.</p>

Table 422. Descriptions of columns in the DSN_STAT_FEEDBACK table (continued)

Column name	Data Type	Descriptions
REMARKS	VARCHAR(254) NOT NULL	Free form text for extensibility.
AP_PLANID	CHAR(16) FOR BIT DATA	A unique identifier for BIND or PREPARE optimizations for an SQL statement, in the form of an extended timestamp value.

PSPI

Related tasks

- [Controlling the collection of statistics feedback \(Db2 Performance\)](#)
- [Applying statistics recommendations to statistics profiles automatically \(Db2 Performance\)](#)
- [Maintaining Db2 database statistics \(Db2 Performance\)](#)

Related reference

- [RUNSTATS \(Db2 Utilities\)](#)
- [Statistics used for access path selection \(Db2 Performance\)](#)
- [SYSSTATFEEDBACK catalog table](#)
- The SYSSTATFEEDBACK table contains information about missing or conflicting catalog statistics for SQL statements. The schema is SYSIBM.

DSN_STRUCT_TABLE

The structure table, DSN_STRUCT_TABLE, contains information about all of the query blocks in a query.

PSPI

Recommendation: Do not manually insert data into system-maintained EXPLAIN tables, and use care when deleting obsolete EXPLAIN table data. The data is intended to be manipulated only by the Db2 EXPLAIN function and optimization tools. Certain optimization tools depend on instances of the various EXPLAIN tables. Be careful not to delete data from or drop instances EXPLAIN tables that are created for these tools.

Qualifiers

Your subsystem or data sharing group can contain multiple instances of these tables that are qualified by user ID. These tables are populated with statement cost information when you issue the EXPLAIN statement or bind. They are also populated when you specify EXPLAIN(YES) or EXPLAIN(ONLY) in a BIND or REBIND command. SQL optimization tools might also create EXPLAIN tables that are qualified by a user ID. You can find the SQL statement for creating an instance of these tables in member DSNTESC of the SDSNSAMP library.

Sample CREATE TABLE statement

You can find a sample CREATE TABLE statement for each EXPLAIN table in member DSNTESC of the *prefix*.SDSNSAMP library. You can call the ADMIN_EXPLAIN_MAINT stored procedure to create EXPLAIN tables, upgrade them to the format for the current Db2 release, or complete other maintenance tasks. See [“ADMIN_EXPLAIN_MAINT stored procedure” on page 751](#) for information about using the *action* input parameter to request each of these tasks.

Column descriptions

The following table describes the columns of DSN_STRUCT_TABLE

Table 423. DSN_STRUCT_TABLE description

Column name	Data type	Description
QUERYNO	INTEGER NOT NULL	<p>A number that identifies the statement that is being explained. The origin of the value depends on the context of the row:</p> <p>For rows produced by EXPLAIN statements The number specified in the QUERYNO clause, which is an optional part of the SELECT, INSERT, UPDATE, MERGE, and DELETE statement syntax.</p> <p>For rows not produced by EXPLAIN statements Db2 assigns a number that is based on the line number of the SQL statement in the source program.</p> <p>When the values of QUERYNO are based on the statement number in the source program, values that exceed 32767 are reported as 0. However, in certain rare cases, the value is not guaranteed to be unique.</p> <p>When the SQL statement is embedded in a compiled SQL function, native SQL procedure, or advanced trigger, if the QUERYNO clause is specified, its value is used by Db2. Otherwise Db2 assigns a number based on the line number of the SQL statement in the compiled SQL function, native SQL procedure, or advanced trigger.</p>
QBLOCKNO	SMALLINT NOT NULL	A number that identifies each query block within a query. The value of the numbers are not in any particular order, nor are they necessarily consecutive.
APPLNAME	VARCHAR(24) NOT NULL	<p>The name of the application plan for the row. Applies only to embedded EXPLAIN statements that are executed from a plan or to statements that are explained when binding a plan. A blank indicates that the column is not applicable.</p> <p>When the SQL statement is embedded in a compiled SQL function, native SQL procedure, or advanced trigger, this column is not used, and is blank.</p>
PROGNAME	VARCHAR(128) NOT NULL	<p>The name of the program or package containing the statement being explained. Applies only to embedded EXPLAIN statements and to statements explained as the result of binding a plan or package. A blank indicates that the column is not applicable.</p> <p>When the SQL statement is embedded in a compiled SQL function or native SQL procedure, this column indicates the specific name of the compiled SQL function or native SQL procedure. When the SQL statement is embedded in an advanced trigger, this column contains the name of the trigger.</p>
PARENT	SMALLINT NOT NULL	The parent query block number of the current query block in the structure of SQL text; this is the same as the PARENT_QBLOCKNO in PLAN_TABLE.
TIMES	FLOAT NOT NULL	The estimated number of rows returned by Data Manager; also the estimated number of times this query block is executed.
ROWCOUNT	INTEGER NOT NULL	The estimated number of rows returned by RDS (Query Cardinality).
ATOPEN	CHAR(1) NOT NULL	Whether the query block is moved up for do-at-open processing; 'Y' if done-at-open; 'N': otherwise.

Table 423. DSN_STRUCT_TABLE description (continued)

Column name	Data type	Description
CONTEXT	CHAR(10) NOT NULL	This column indicates what the context of the current query block is. The possible values are: <ul style="list-style-type: none"> 'TOP LEVEL' 'UNION' 'UNION ALL' 'PREDICATE' 'TABLE EXP' 'UNKNOWN'
ORDERNO	SMALLINT NOT NULL	Not currently used.
DOATOPEN_PARENT	SMALLINT NOT NULL	The parent query block number of the current query block; Do-at-open parent if the query block is done-at-open, this may be different from the PARENT_QBLOCKNO in PLAN_TABLE.
QBLOCK_TYPE	CHAR(6) NOT NULL WITH DEFAULT	This column indicates the type of the current query block. The possible values are <ul style="list-style-type: none"> 'SELECT' 'INSERT' 'UPDATE' 'DELETE' 'SELUPD' 'DELCUR' 'UPDCUR' 'CORSUB' 'NCOSUB' 'TABLEX' 'TRIGGR' 'UNION' 'UNIONA' 'CTE' <p>It is equivalent to QBLOCK_TYPE column in PLAN_TABLE, except for CTE.</p>
EXPLAIN_TIME	TIMESTAMP NOT NULL	The time when the EXPLAIN information was captured: <p>All cached statements When the statement entered the cache, in the form of a full-precision timestamp value.</p> <p>Non-cached static statements When the statement was bound, in the form of a full precision timestamp value.</p> <p>Non-cached dynamic statements When EXPLAIN was executed, in the form of a value equivalent to a CHAR(16) representation of the time appended by 4 zeros.</p>

Table 423. DSN_STRUCT_TABLE description (continued)

Column name	Data type	Description
QUERY_STAGE	CHAR(8) NOT NULL	IBM internal use only.
GROUP_MEMBER	VARCHAR(24) NOT NULL	The member name of the Db2 that executed EXPLAIN. The column is blank if the Db2 subsystem was not in a data sharing environment when EXPLAIN was executed.
ORIGIN	CHAR(1) NOT NULL WITH DEFAULT	Indicates the origin of the query block: Blank Generated by Db2 C Column mask R Row permission U Specified by the user
SECTNOI	INTEGER NOT NULL WITH DEFAULT	The section number of the statement. The value is taken from the same column in SYSPACKSTMT or SYSSTMT tables and can be used to join tables to reconstruct the access path for the statement. This column is applicable only for static statements. The default value of -1 indicates EXPLAIN information that was captured in DB2 9 or earlier.
COLLID	VARCHAR(128) NOT NULL WITH DEFAULT	The collection ID: 'DSNEXPLAINMODEYES' The row originates from an application that specifies YES for the value of the CURRENT EXPLAIN MODE special register. 'DSNEXPLAINMODEEXPLAIN' The row originates from an application that specifies EXPLAIN for the value of the CURRENT EXPLAIN MODE special register. When the SQL statement is embedded in a compiled SQL function, native SQL procedure, or advanced trigger, this column indicates the schema name of the compiled SQL function, native SQL procedure, or advanced trigger.

Table 423. DSN_STRUCT_TABLE description (continued)

Column name	Data type	Description
VERSION	VARCHAR(122) NOT NULL WITH DEFAULT	<p>The version identifier for the package. Applies only to an embedded EXPLAIN statement executed from a package or to a statement that is explained when binding a package.</p> <p>If the value is not blank, the value is the same as the VERSION value for the package that was used to create this EXPLAIN table row.</p> <p>The value is blank for a statement in:</p> <ul style="list-style-type: none">• A package for a basic trigger (TYPE='T')• A package for an application that was precompiled without SQL processing option VERSION• A package that was precompiled with an empty string for the VERSION value (TYPE=blank) <p>When the SQL statement is embedded in a compiled SQL function or native SQL procedure, this column indicates the version identifier of the function or procedure. When the SQL statement is embedded in an advanced trigger body, this column is not used and will be blank.</p>

Table 423. DSN_STRUCT_TABLE description (continued)

Column name	Data type	Description
EXPANSION_REASON	CHAR(2) NOT NULL WITH DEFAULT	<p>This column applies only to statements that reference archive tables or temporal tables. For other statements, this column is blank.</p> <p>Indicates the effect of the CURRENT TEMPORAL BUSINESS_TIME special register, the CURRENT TEMPORAL SYSTEM_TIME special register, and the SYSIBMADM.GET_ARCHIVE built-in global variable. These items are controlled by the BUSTIMESENSITIVE, SYSTIMESENSITIVE, and ARCHIVESENSITIVE bind options.</p> <p>Db2 implicitly adds certain syntax to the query if one of the following conditions are true:</p> <ul style="list-style-type: none"> • The SYSIBMADM.GET_ARCHIVE global variable is set to Y and the ARCHIVESENSITIVE bind option is set to YES • The CURRENT TEMPORAL BUSINESS_TIME special register is not null and the BUSTIMESENSITIVE bind option is set to YES • The CURRENT TEMPORAL SYSTEM_TIME special register is not null and the SYSTIMESENSITIVE bind option is set to YES <p>This column can have one of the following values:</p> <p>'A' The query contains implicit query transformation as a result of the SYSIBMADM.GET_ARCHIVE built-in global variable.</p> <p>'B' The query contains implicit query transformation as a result of the CURRENT TEMPORAL BUSINESS_TIME special register.</p> <p>'S' The query contains implicit query transformation as a result of the CURRENT TEMPORAL SYSTEM_TIME special register.</p> <p>'SB' The query contains implicit query transformation as a result of the CURRENT TEMPORAL SYSTEM_TIME special register and the CURRENT TEMPORAL BUSINESS_TIME special register.</p> <p>blank The query does not contain implicit query transformation.</p>
PER_STMT_ID	BIGINT NOT NULL	<p>The persistent statement identifier for SQL statements in Db2 catalog tables.</p> <p>For example, this column corresponds to the following catalog table columns that identify SQL statements:</p> <ul style="list-style-type: none"> • STMT_ID in SYSIBM.SYSPACKSTMT, for SQL statements in packages. • SDQ_STMT_ID in SYSIBM.SYSDYNQUERY, for stabilized dynamic SQL statements.
AP_PLANID	CHAR(16) FOR BIT DATA	A unique identifier for BIND or PREPARE optimizations for an SQL statement, in the form of an extended timestamp value.

DSN_VIEWREF_TABLE

The view reference table, DSN_VIEWREF_TABLE, contains information about all of the views and materialized query tables that are used to process a query.

PSP1

Recommendation: Do not manually insert data into system-maintained EXPLAIN tables, and use care when deleting obsolete EXPLAIN table data. The data is intended to be manipulated only by the Db2 EXPLAIN function and optimization tools. Certain optimization tools depend on instances of the various EXPLAIN tables. Be careful not to delete data from or drop instances EXPLAIN tables that are created for these tools.

Qualifiers

Your subsystem or data sharing group can contain multiple instances of these tables that are qualified by user ID. These tables are populated with statement cost information when you issue the EXPLAIN statement or bind. They are also populated when you specify EXPLAIN(YES) or EXPLAIN(ONLY) in a BIND or REBIND command. SQL optimization tools might also create EXPLAIN tables that are qualified by a user ID. You can find the SQL statement for creating an instance of these tables in member DSNTESC of the SDSNSAMP library.

Sample CREATE TABLE statement

You can find a sample CREATE TABLE statement for each EXPLAIN table in member DSNTESC of the *prefix*.SDSNSAMP library. You can call the ADMIN_EXPLAIN_MAINT stored procedure to create EXPLAIN tables, upgrade them to the format for the current Db2 release, or complete other maintenance tasks. See [“ADMIN_EXPLAIN_MAINT stored procedure” on page 751](#) for information about using the *action* input parameter to request each of these tasks.

Column descriptions

The following table describes the columns of DSN_VIEWREF_TABLE.

Table 424. DSN_VIEWREF_TABLE description

Column name	Data type	Description
QUERYNO	INTEGER NOT NULL WITH DEFAULT	<p>A number that identifies the statement that is being explained. The origin of the value depends on the context of the row:</p> <p>For rows produced by EXPLAIN statements The number specified in the QUERYNO clause, which is an optional part of the SELECT, INSERT, UPDATE, MERGE, and DELETE statement syntax.</p> <p>For rows not produced by EXPLAIN statements Db2 assigns a number that is based on the line number of the SQL statement in the source program.</p> <p>When the values of QUERYNO are based on the statement number in the source program, values that exceed 32767 are reported as 0. However, in certain rare cases, the value is not guaranteed to be unique.</p> <p>When the SQL statement is embedded in a compiled SQL function, native SQL procedure, or advanced trigger, if the QUERYNO clause is specified, its value is used by Db2. Otherwise Db2 assigns a number based on the line number of the SQL statement in the compiled SQL function, native SQL procedure, or advanced trigger.</p>

Table 424. DSN_VIEWREF_TABLE description (continued)

Column name	Data type	Description
APPLNAME	VARCHAR(24) NOT NULL WITH DEFAULT	<p>The name of the application plan for the row. Applies only to embedded EXPLAIN statements that are executed from a plan or to statements that are explained when binding a plan. A blank indicates that the column is not applicable.</p> <p>When the SQL statement is embedded in a compiled SQL function, native SQL procedure, or advanced trigger, this column is not used, and is blank.</p>
PROGNAME	VARCHAR(128) NOT NULL WITH DEFAULT	<p>The name of the program or package containing the statement being explained. Applies only to embedded EXPLAIN statements and to statements explained as the result of binding a plan or package. A blank indicates that the column is not applicable.</p> <p>When the SQL statement is embedded in a compiled SQL function or native SQL procedure, this column indicates the specific name of the compiled SQL function or native SQL procedure. When the SQL statement is embedded in an advanced trigger, this column contains the name of the trigger.</p>
VERSION	VARCHAR(122) NOT NULL WITH DEFAULT	<p>The version identifier for the package. Applies only to an embedded EXPLAIN statement executed from a package or to a statement that is explained when binding a package.</p> <p>If the value is not blank, the value is the same as the VERSION value for the package that was used to create this EXPLAIN table row.</p> <p>The value is blank for a statement in:</p> <ul style="list-style-type: none"> • A package for a basic trigger (TYPE='T') • A package for an application that was precompiled without SQL processing option VERSION • A package that was precompiled with an empty string for the VERSION value (TYPE=blank) <p>When the SQL statement is embedded in a compiled SQL function or native SQL procedure, this column indicates the version identifier of the function or procedure. When the SQL statement is embedded in an advanced trigger body, this column is not used and will be blank.</p>
COLLID	VARCHAR(128) NOT NULL WITH DEFAULT	<p>The collection ID:</p> <p>'DSNEXPLAINMODEYES' The row originates from an application that specifies YES for the value of the CURRENT EXPLAIN MODE special register.</p> <p>'DSNEXPLAINMODEEXPLAIN' The row originates from an application that specifies EXPLAIN for the value of the CURRENT EXPLAIN MODE special register.</p> <p>When the SQL statement is embedded in a compiled SQL function, native SQL procedure, or advanced trigger, this column indicates the schema name of the compiled SQL function, native SQL procedure, or advanced trigger.</p>

Table 424. DSN_VIEWREF_TABLE description (continued)

Column name	Data type	Description
CREATOR	VARCHAR(128) NOT NULL WITH DEFAULT	Authorization ID of the owner of the object.
NAME	VARCHAR(128)	Name of the object.
TYPE	CHAR(1) NOT NULL WITH DEFAULT	The type of the object: 'V' View 'R' MQT that has been used to replace the base table for rewrite 'M' MQT
MQTUSE	SMALLINT WITH DEFAULT	IBM internal use only.
EXPLAIN_TIME	TIMESTAMP NOT NULL WITH DEFAULT	The time when the EXPLAIN information was captured: All cached statements When the statement entered the cache, in the form of a full-precision timestamp value. Non-cached static statements When the statement was bound, in the form of a full precision timestamp value. Non-cached dynamic statements When EXPLAIN was executed, in the form of a value equivalent to a CHAR(16) representation of the time appended by 4 zeros.
GROUP_MEMBER	VARCHAR(24) NOT NULL	The member name of the Db2 that executed EXPLAIN. The column is blank if the Db2 subsystem was not in a data sharing environment when EXPLAIN was executed.
SECTNOI	INTEGER NOT NULL WITH DEFAULT	The section number of the statement. The value is taken from the same column in SYSPACKSTMT or SYSSTMT tables and can be used to join tables to reconstruct the access path for the statement. This column is applicable only for static statements. The default value of -1 indicates EXPLAIN information that was captured in DB2 9 or earlier.

Table 424. DSN_VIEWREF_TABLE description (continued)

Column name	Data type	Description
EXPANSION_REASON	CHAR(2) NOT NULL WITH DEFAULT	<p>This column applies only to statements that reference archive tables or temporal tables. For other statements, this column is blank.</p> <p>Indicates the effect of the CURRENT TEMPORAL BUSINESS_TIME special register, the CURRENT TEMPORAL SYSTEM_TIME special register, and the SYSIBMADM.GET_ARCHIVE built-in global variable. These items are controlled by the BUSTIMESENSITIVE, SYSTIMESENSITIVE, and ARCHIVESENSITIVE bind options.</p> <p>Db2 implicitly adds certain syntax to the query if one of the following conditions are true:</p> <ul style="list-style-type: none"> • The SYSIBMADM.GET_ARCHIVE global variable is set to Y and the ARCHIVESENSITIVE bind option is set to YES • The CURRENT TEMPORAL BUSINESS_TIME special register is not null and the BUSTIMESENSITIVE bind option is set to YES • The CURRENT TEMPORAL SYSTEM_TIME special register is not null and the SYSTIMESENSITIVE bind option is set to YES <p>This column can have one of the following values:</p> <p>'A' The query contains implicit query transformation as a result of the SYSIBMADM.GET_ARCHIVE built-in global variable.</p> <p>'B' The query contains implicit query transformation as a result of the CURRENT TEMPORAL BUSINESS_TIME special register.</p> <p>'S' The query contains implicit query transformation as a result of the CURRENT TEMPORAL SYSTEM_TIME special register.</p> <p>'SB' The query contains implicit query transformation as a result of the CURRENT TEMPORAL SYSTEM_TIME special register and the CURRENT TEMPORAL BUSINESS_TIME special register.</p> <p>blank The query does not contain implicit query transformation.</p>
AP_PLANID	CHAR(16) FOR BIT DATA	A unique identifier for BIND or PREPARE optimizations for an SQL statement, in the form of an extended timestamp value.



Appendix M. Tables that support query acceleration

To interact with accelerator servers, Db2 requires several tables that record characteristics of accelerated servers and tables.

The following table lists these tables, the table spaces and indexes for these tables, and the index fields for each index. The indexes are in ascending order, except where noted.

Table 425. Tables, table spaces, and indexes for tables that support acceleration of queries

Table	Description	Table space*	Indexes	Index fields
“SYSACCEL.SYSACCELERATORS table” on page 2931	Records the characteristics of accelerator servers.	SYSTSACC	DSNACC01	ACCELERATORNAME
“SYSACCEL.SYSACCELERATEDTABLES table” on page 2932	Records the characteristics of each table that is marked for acceleration.	SYSTSACT	DSNACT01	CREATOR, NAME, ACCELERATORNAME
“SYSACCEL.SYSACCELERATEDPACKAGES table” on page 2934	Records the characteristics of Db2 packages that are bound with the QUERYACCELERATION and GETACCELARCHIVE bind options.	SYSTSACP	DSNACP01	LOCATION, COLLID, NAME, VERSION
			DSNACP02	LOCATION, COLLID, NAME, CONTOKEN
“SYSACCEL.SYSACCELERATEDTABLESAUTH table” on page 2934	Records the privileges that are held by user users over tables that are enabled for acceleration.	SYSTSATA	DSNATA01	TCREATOR, TNAME, ACCELERATORNAME, GRANTEE

* The table spaces listed in this table are universal table spaces (UTSs). Prior to these table spaces being migrated to type UTS, all of the catalog tables for accelerated queries used the SYSACCEL segmented table space. SYSACCEL is still supported; however, segmented table spaces have been deprecated. If you want to migrate from the single SYSACCEL segmented table space, see [Migrating query acceleration tables to universal table spaces \(Db2 Installation and Migration\)](#).

Related tasks

[Creating database objects that support query acceleration \(Db2 Installation and Migration\)](#)

SYSACCEL.SYSACCELERATORS table

The SYSACCEL.SYSACCELERATORS table contains rows that describe the characteristics of each accelerator server.

Rows in this table can be inserted, updated, and deleted.

Column name	Data type	Description	Use
ACCELERATOR-NAME	VARCHAR(128) NOT NULL	A unique name for the accelerator server. This is the name by which the accelerator server is known to the local Db2 accelerated query tables.	G

Column name	Data type	Description	Use
LOCATION	VARCHAR(128)	Identifies the location name that is associated with the accelerator server.	G
ACCELERATORSRL	CHAR(64) FOR BIT DATA	Internal use only	I
ACCELERATOR_TYPE	SMALLINT NOT NULL	The type of accelerator: 1 Indicates Version 5 or earlier of IBM Db2 Analytics Accelerator for z/OS (an <i>on-premises</i> accelerator hardware appliance based on IBM PureData® System for Analytics and IBM Netezza® technology). 2 Indicates Version 7 of IBM Db2 Analytics Accelerator for z/OS. The default value is 1.	G

SYSACCEL.SYSACCELERATEDTABLES table

The SYSACCEL.SYSACCELERATEDTABLES table contains rows that describe the characteristics of each table that is marked for acceleration.

Rows in this table can be inserted, updated, and deleted.

Column name	Data type	Description	Use
NAME	VARCHAR(128) NOT NULL	The name of the table.	G
CREATOR	VARCHAR(128) NOT NULL	The schema of the table.	G
ACCELERATORNAME	VARCHAR(128) NOT NULL	A unique name for the accelerator server. This is the name by which the accelerator server is known to the local Db2 accelerated query tables.	G
REMOTENAME	VARCHAR(128) NOT NULL	The name of the base alias object.	G
REMOTECREATOR	VARCHAR(128) NOT NULL	The owner of the base alias object.	G
ENABLE	CHAR(1) NOT NULL	Indicates whether the remote table is enabled or disabled for query acceleration: Y Enabled N Disabled T Transition state. Queries are not sent to an accelerator server.	G

Column name	Data type	Description	Use
CREATEDBY	VARCHAR(128) NOT NULL	The primary authorization ID of the user who created the table.	G
CREATEDTS	TIMESTAMP NOT NULL WITH DEFAULT	The time when the CREATE statement was executed for the table.	G
ALTEREDTS	TIMESTAMP NOT NULL WITH DEFAULT	The time when the table was last altered.	G
REFRESH_TIME	TIMESTAMP NOT NULL WITH DEFAULT	The timestamp when the data was last refreshed. If the data was not refreshed, this column contains the default timestamp ('0001-01-01.00.00.00.000000').	G
SUPPORTLEVEL	SMALLINT NOT NULL	Internal use only.	I
ARCHIVE	CHAR(1)	The archive status of the table in the accelerator database: A The table is archived in the accelerator server that is specified by the ACCELERATORNAME value. The accelerator server contains active and archived data. B The table is partially archived in the accelerator server that is specified by the ACCELERATORNAME value. The accelerator server can answer queries that contain active data. C The table is archived in other accelerator servers. The accelerator server that is specified by the ACCELERATORNAME value contains only active data. X The table was restored on another accelerator server. The accelerator server that is specified by the ACCELERATORNAME value cannot answer queries. blank The table is not archived in an accelerator server.	G
REMOTELLOCATION	VARCHAR(128) NOT NULL WITH DEFAULT	The location of the owner table of the referenced accelerator-only table. For tables that are not referenced accelerator-only tables, this column is blank.	G
<u>FL 509</u> FEATURE	INTEGER NOT NULL	Indicates additional features of the table: 0 The table does not have any of the additional features that are indicated by the other values. 0 is the default value. 1 The table is a high availability accelerator-only table.	G

SYSACCEL.SYSACCELERATEDTABLESAUTH table

The SYSACCEL.SYSACCELERATEDTABLESAUTH table records the privileges that are held by users over tables that are enabled for acceleration.

Column name	Data type	Description	Use
ACCELERATORNAME	VARCHAR(128) NOT NULL	A unique name for the accelerator server. This is the name by which the accelerator server is known to the local Db2 accelerated query tables.	G
GRANTOR	VARCHAR(128) NOT NULL	Authorization ID of the user who granted the privilege.	G
GRANTEE	VARCHAR(128) NOT NULL	Grantee who holds the privileges to access the table in the accelerator. Currently, only a location name for a referencing Db2 for z/OS subsystem is supported. The location name must be the name of a Db2 for z/OS subsystem that was paired to the accelerator when the ACCEL_GRANT_TABLES_REFERENCE stored procedure granted the privilege.	G
GRANTEETYPE	CHAR(1) NOT NULL	Indicates the type of grantee: S Subsystem location name	G
TCREATOR	VARCHAR(128) NOT NULL	The schema of the table.	G
TNAME	VARCHAR(128) NOT NULL	The name of the table.	G
SELECTAUTH	CHAR(1) NOT NULL	Indicates whether the GRANTEE can select rows from the table or view: blank Privilege is not held. Y Privilege is held without the GRANT option.	G
GRANTEDTS	TIMESTAMP NOT NULL WITH DEFAULT	The time when the GRANT statement was executed for the table.	G

SYSACCEL.SYSACCELERATEDPACKAGES table

The SYSACCEL.SYSACCELERATEDPACKAGES table contains rows that describe the characteristics of Db2 packages that are bound with the QUERYACCELERATION and GETACCELARCHIVE bind options.

Do not modify the definition of the SYSACCEL.SYSACCELERATEDPACKAGES table or its indexes unless directed by IBM Support.

Column name	Data type	Description	Use
LOCATION	VARCHAR(128) NOT NULL	Always contains blanks.	S
COLLID	VARCHAR(128) NOT NULL	The name of the package collection.	G
NAME	VARCHAR(128) NOT NULL	The name of the package.	G
CONTOKEN	CHAR(8) NOT NULL FOR BIT DATA	Consistency token for the package.	S
VERSION	VARCHAR(122) NOT NULL	Version identifier for the package.	G
OWNER	VARCHAR(128) NOT NULL	Authorization ID of the package owner.	G
CREATOR	VARCHAR(128) NOT NULL	Authorization ID of the owner of the creator of the package version.	G
TIMESTAMP	TIMESTAMP NOT NULL	Timestamp indicating when the package was created.	G
BINDTIME	TIMESTAMP NOT NULL	Timestamp indicating when the package was last bound.	G
RELBOUND	CHAR(1) NOT NULL	The Db2 release when the package was bound or rebound.	G
TYPE	CHAR(1) NOT NULL	Type of package. Identifies how the package is created: F A CREATE FUNCTION or ALTER FUNCTION statement, or a BIND PACKAGE DEPLOY command created the package, and this package is a non-inline SQL scalar function package. N A CREATE PROCEDURE or ALTER PROCEDURE statement, or a BIND PACKAGE DEPLOY command created the package, and this package is a native SQL routine package. blank A BIND PACKAGE command created the package.	G
COPYID	INTEGER NOT NULL	Internal use only. The value is zero.	I

Column name	Data type	Description	Use
QUERYACCELERATION	CHAR(1) NOT NULL	<p>Indicates the query acceleration behavior that is specified for the static SQL queries in the package. This behavior can also apply to dynamic queries in the package if the package does not issue an explicit SET for the CURRENT QUERY ACCELERATION special register. The QUERYACCELERATION bind option does not have a default value.</p> <p>N NONE. No static SQL query in the package is bound for acceleration or will be accelerated when the package runs. NONE is not a default value.</p> <p>E ENABLE. A static SQL query is bound for acceleration if it satisfies the acceleration criteria, including the cost and heuristics criteria. The query is routed to an accelerator when the application runs.</p> <p>If a static query does not satisfy the acceleration criteria, the query is bound for execution in Db2.</p> <p>F ENABLEWITHFAILBACK. Same behavior as ENABLE, except if an error occurs on the first OPEN of the accelerated static query when the application runs. In this case, instead of failing the query and returning a negative SQL code to the application, Db2 performs a temporary <i>statement-level</i> incremental bind of the query and runs the query in Db2.</p> <p>L ELIGIBLE. A static SQL query is bound for acceleration if the query meets the basic acceleration criteria, regardless of the cost or heuristics criteria. The query is routed to the accelerator when the application runs.</p> <p>A ALL. All static SQL queries in the application are to be bound for acceleration and routed to the accelerator when the application runs. If Db2 determines that a static query cannot be bound to run on the accelerator and the query references a user base table or view, Db2 fails the BIND or REBIND PACKAGE operation with an error message for that query.</p>	G

Column name	Data type	Description	Use
GETACCELARCHIVE	CHAR(1) NOT NULL	<p>Indicates whether a static SQL query should retrieve archived data from the accelerator instead of active data from the accelerator. This behavior can also apply to dynamic queries in the package if the package does not issue an explicit SET for the CURRENT GET_ACCEL_ARCHIVE special register. The GETACCELARCHIVE bind option does not have a default value.</p> <p>N</p> <p>NO. No static SQL query is bound to retrieve archived data from the accelerator. If the static query also is not bound for acceleration, the query is bound to run in Db2.</p> <p>If the static query is bound for acceleration because the QUERYACCELERATION bind option is specified, when the application is run the query is routed to the accelerator. However, the query retrieves only active data on the accelerator. Archived data is not retrieved.</p> <p>Y</p> <p>YES. If the static query is bound for acceleration, the query retrieves archived data on the accelerator when the application runs if the following criteria is met:</p> <ul style="list-style-type: none"> • The QUERYACCELERATION bind option is also specified. • The static SQL query references an accelerated table that has partitioned data archived on an accelerator. <p>If the static query cannot be bound for acceleration, Db2 fails the BIND or REBIND PACKAGE operation with an error message for that query.</p>	G
ACCELERATOR	VARCHAR(128) NOT NULL	<p>Indicates the preferred target accelerator or accelerators to be used for queries accelerated from this Db2 package:</p> <p><i>accelerator-name</i></p> <p>An unqualified name that identifies an accelerator. An accelerator name can consist of 1–8 uppercase characters or numbers. The name must be unique within the Db2 subsystem or data sharing group. This name can be a physical accelerator name or a logical name (alias) that maps to a physical accelerator name or a group of physical accelerator names.</p> <p>blank</p> <p>If the ACCELERATOR bind option not specified, this is the default value, which indicates that no preferred target accelerator will be used and Db2 will determine the target accelerator.</p>	G

Column name	Data type	Description	Use
ACCELERATION_WAITFOR RDATA	DECIMAL(5,1) NOT NULL	<p>Indicates the maximum amount of time, if any, that the accelerator will delay a query while the accelerator waits for the replication of committed Db2 data changes that occurred prior to Db2 running the query.</p> <p><i>nnnn.m</i> If the ACCELERATIONWAITFORDATA bind option is specified, this value indicates the maximum decimal number of seconds that the accelerator will delay the query when needed.</p> <p>-1.0 If the ACCELERATIONWAITFORDATA bind option is not specified, this is the default value of this catalog column. Db2 considers this as the default value of 0.0. No accelerator delay is requested, and static queries accelerated from this Db2 package will not be delayed.</p>	G

Appendix N. Tables that are used for program authorization

For program authorization, a table is provided to record the authorization for a program to execute a plan.

Table spaces and indexes for program authorization

Tables that are used for program authorization are contained in certain table spaces and have indexes.

The following table lists the table space and index for the table that is used for program authorization, and lists the index fields for the index. The index is in ascending order.

Table 426. Table spaces and indexes for the tables that are used for program authorization

TABLE SPACE DSNMDCDB. ...	TABLE SYSIBM. ...	INDEX SYSIBM. ...	INDEX FIELDS
DSNMDCTS	DSNPROGAUTH	DSNPROGAUTH_IDX 1	PROGNAME.PLANNAME

SYSIBM.DSNPROGAUTH table

The SYSIBM.DSNPROGAUTH table enables program authorization with or without program data integrity checking.

Column name	Data type	Description	Use
PROGNAME	VARCHAR(24) NOT NULL	Name of the application program that can run the plan.	G
PLANNAME	VARCHAR(24) NOT NULL	Name of the application plan for the application program.	G
PROGMDCVAL	CHAR(16) NOT NULL FOR BIT DATA WITH DEFAULT X'0000000000000000 0- 0000000000000000 0'	Reserved.	G
PROGMDCPAD	CHAR(1) NOT NULL WITH DEFAULT	Reserved.	G
CREATOR	VARCHAR(128) NOT NULL WITH DEFAULT CURRENT SQLID	The authorization ID under which the row was inserted or most recently updated.	G

Column name	Data type	Description	Use
ENABLED	CHAR(1) NOT NULL WITH DEFAULT 'N'	Whether program authorization is enabled: Y Program authorization is enabled. N Program authorization is disabled.	
CREATETS	TIMESTAMP NOT NULL WITH DEFAULT	The time at which the row was inserted or most recently updated.	G
REMARKS	VARCHAR(762)	A user-specified character string.	G

Appendix O. Sample user-defined functions

Some sample user-defined functions are provided with Db2. You can use the functions in your applications just as you would use other user-defined functions, or as examples to help you define your own user-defined functions.

All REST functions are created by installation job DSNTIJRF or the `createUDFzOS.sql` script and can be used to allow applications to access REST-based services through SQL. For all other sample functions, the following points apply:

- To use these functions in your applications: Use the functions only if installation job DSNTEJ2U, which prepares the functions for use, has been run. Because the external programs that implement the logic of the sample functions are written in C and C++, the installation job requires that your site has IBM C/C++ for z/OS. For information, see [Job DSNTEJ2U \(Db2 Installation and Migration\)](#).
- If you want to use these functions as examples to help you define and implement your own user-defined functions: Data set `prefix.SDSNSAMP` contains the code for the sample functions.
- The detailed descriptions of the functions include their external program names and specific names. The functions are in schema DSN8. The functions are defined to treat character or graphic string parameters, both input and output, as EBCDIC-encoded data.

Related concepts

[Job DSNTEJ2U \(Db2 Installation and Migration\)](#)

Related tasks

[Examples of granting privileges for routines \(Managing Security\)](#)

[Creating REST user-defined functions \(Db2 Installation and Migration\)](#)

Related reference

[User-defined function samples that ship with Db2 \(Db2 Application programming and SQL\)](#)

ALTDATE

The ALTDATE function returns the current date in the specified format or converts a user-specified date from one format to another.

```
▶▶ ALTDATE( input-date, input-format, output-format ) ▶▶
```

The schema is DSN8.

The ALTDATE function returns the current date in one of the following formats or converts a user-specified date from one format to another:

D MONTH YY	D MONTH YYYY	DD MONTH YY	DD MONTH YYYY
D.M.YY	D.M.YYYY	DD.MM.YY	DD.MM.YYYY
D-M-YY	D-M-YYYY	DD-MM-YY	DD-MM-YYYY
D/M/YY	D/M/YYYY	DD/MM/YY	DD/MM/YYYY
M/D/YY	M/D/YYYY	MM/DD/YY	MM/DD/YYYY
YY/M/D	YYYY/M/D	YY/MM/DD	YYYY/MM/DD
YY.M.D	YYYY.M.D	YY.MM.DD	YYYY.MM.DD
	YYYY-M-D		YYYY-MM-DD
	YYYY-D-XX		YYYY-DD-XX
	YYYY-XX-D		YYYY-XX-DD

where:

D: Suppress leading zero if the day is less than 10
DD: Retain leading zero if the day is less than 10
M: Suppress leading zero if the month is less than 10
MM: Retain leading zero if the month is less than 10
MONTH: Use English-language name of month
XX: Use a capital Roman numeral for month

YY: Use a year format without century
 YYYY: Use a year format with century

The ALTDATE function demonstrates how you can create an overloaded function—a function name for which there are multiple function instances. Each instance supports a different parameter list enabling you to group related but distinct functions in a single user-defined function. The ALTDATE function has two forms.

Form 1: ALTDATE(*output-format*)

This form of the function converts the current date into the specified format.

output-format

A character string that matches one of the 34 date formats that are shown above. The character string must have a data type of VARCHAR and an actual length that is not greater than 13 bytes.

The result of the function is VARCHAR(17).

Form 2: ALTDATE(*input-date*, *input-format*, *output-format*)

This form of the function converts a date (*input-date*) in one user-specified format (*input-format*) into another format (*output-format*).

input-date

The argument must be a date or a character string representation of a date in the format specified by *input-format*. The character string must have a data type of VARCHAR and an actual length that is not greater than 17 bytes.

input-format

A character string that matches one of the 34 date formats that are shown above. The character string must have a data type of VARCHAR and an actual length that is not greater than 13 bytes.

output-format

A character string that matches one of the 34 date formats that are shown above. The character string must have a data type of VARCHAR and an actual length that is not greater than 13 bytes.

The result of the function is VARCHAR(17).

The following table shows the external and specific names for the two forms of the function, which are based on the input to the function.

Table 427. External program and specific names for ALTDATE

Conversion type	Input arguments	External name	Specific name
Current date	<i>output-format</i> (VARCHAR)	DSN8DUAD	DSN8.DSN8DUADV
User-specified date	<i>input-date</i> (VARCHAR) <i>input-format</i> (VARCHAR) <i>output-format</i> (VARCHAR)	DSN8DUCD	DSN8.DSN8DUCDVVV
	<i>input-date</i> (DATE) <i>input-format</i> (VARCHAR) <i>output-format</i> (VARCHAR)	DSN8DUCD	DSN8.DSN8DUCDDVV

Example 1: Convert the current date into format 'DD MONTH YY', a format that will include any leading zero for the month, the name of the month in English, and the year without the two digits for the century.

```
VALUES DSN8.ALTDATE( 'DD MONTH YY' );
```

Example 2: Convert the current date into format 'D.M.YYYY', a format that will suppress any leading zero for the day or month and include the year with the century.

```
VALUES DSN8.ALTDATE( 'D.M.YYYY' );
```

Example 3: Convert the current date into format 'YYYY-XX-DD', a format that will include the century, the month of the year as a roman numeral, and the day of the month with any leading zero.

```
VALUES DSN8.ALTDATE( 'YYYY-XX-DD' );
```

Example 4: Convert a date in the format of 'DD MONTH YYYY' to a date in the format of 'YYYY/MM/DD'.

```
VALUES DSN8.ALTDATE( '11 November 1918',
                    'DD MONTH YYYY',
                    'YYYY/MM/DD' );
```

The result of the above example is '1918/11/18'.

Example 5: Convert the date that employee 000130 was hired, a date in ISO format, into the format of 'D.M.YY'.

```
SELECT FIRSTNAME || ' '
       || LASTNAME || ' was hired on '
       || DSN8.ALTDATE( HIREDATE,
                       'YYYY-MM-DD',
                       'D.M.YY' )
FROM   EMP
WHERE  EMPNO = '000130';
```

Assuming that the HIREDATE is '1971-07-28', the above example returns: 'DELORES QUINTANA was hired on 28.7.71'.

ALTTIME

The ALTTIME function returns the current time in the specified format or converts a user-specified time from one format to another.

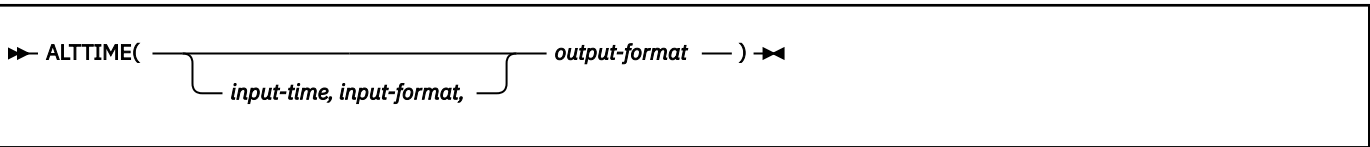

The schema is DSN8.

The ALTTIME function returns the current time in one of the following formats or converts a user-specified time from one of the formats to another:

H:MM AM/PM	HH:MM AM/PM
HH:MM:SS AM/PM	HH:MM:SS
H.MM	HH.MM
H.MM.SS	HH.MM.SS

where:

- H: Suppress leading zero if the hour is less than 10
- HH: Retain leading zero if the hour is less than 10
- M: Suppress leading zero if the minute is less than 10
- MM: Retain leading zero if the minute is less than 10
- AM/PM: Return time in 12-hour clock format, else 24-hour

The ALTTIME function demonstrates how you can create an overloaded function—a function name for which there are multiple function instances. Each instance supports a different parameter list enabling you to group related but distinct functions in a single user-defined function. The ALTTIME function has two forms.

Form 1: ALTTIME(output-format)

This form of the function converts the current time into the specified format.

output-format

A character string that matches one of the 8 time formats that are shown above. The character string must have a data type of VARCHAR and an actual length that is not greater than 14 bytes.

The result of the function is VARCHAR(11).

Form 2: ALTTIME(*input-time*, *input-format*, *output-format*)

This form of the function converts a time (*input-date*) in one user-specified format (*input-format*) into another format (*output-format*).

input-time

The argument must be a time or a character string representation of a time in the format specified by *input-format*. A character string argument must have a data type of VARCHAR and an actual length that is not greater than 11 bytes.

input-format

A character string that matches one of the 8 time formats that are shown above. The character string must have a data type of VARCHAR and an actual length that is not greater than 14 bytes.

output-format

A character string that matches one of the 8 time formats that are shown above. The character string must have a data type of VARCHAR and an actual length that is not greater than 14 bytes.

The result of the function is VARCHAR(11).

The following table shows the external program and specific names for the two forms of the function, which are based on the input to the function.

Table 428. External and specific names for ALTTIME

Conversion type	Input arguments	External name	Specific name
Current time	<i>output-format</i> (VARCHAR)	DSN8DUAT	DSN8.DSN8DUATV
User-specified time	<i>input-time</i> (VARCHAR) <i>input-format</i> (VARCHAR) <i>output-format</i> (VARCHAR)	DSN8DUCT	DSN8.DSN8DUCTVVV
	<i>input-time</i> (TIME) <i>input-format</i> (VARCHAR) <i>output-format</i> (VARCHAR)	DSN8DUCT	DSN8.DSN8DUCTTVV

Example 1: Convert the current time into a 12-hour clock format without seconds, 'H.MM AM/PM'.

```
VALUES DSN8.ALTTIME( 'H:MM AM/PM' );
```

Example 2: Convert the current time into a 24-hour clock format without seconds, 'HH.MM'.

```
VALUES DSN8.ALTTIME( 'HH.MM' );
```

Example 3: Convert the current time into a 24-hour clock format with seconds, 'HH.MM.SS'.

```
VALUES DSN8.ALTTIME( 'HH.MM.SS' );
```

Example 4: Convert '00:00:00', a time in 24-hour clock format with seconds, to a time in 12-hour clock format without seconds.

```
VALUES DSN8.ALTTIME( '00:00:00', 'HH:MM:SS', 'HH:MM AM/PM' );
```

The function returns '12:00 AM'.

Example 5: Convert '00:00:00', a time in 24-hour clock format with seconds, to a time in 12-hour clock format without seconds and without any leading zero on the hour.

```
VALUES DSN8.ALTTIME( '06.42.37', 'HH.MM.SS', 'H:MM AM/PM' );
```

The function returns '6:42 AM'.

BASE64ENCODE and BASE64DECODE

The BASE64ENCODE and BASE64DECODE helper REST functions complete Base64 encoding or decoding of the provided text.

Tip: The sample HTTP user-defined functions are intended to be used within Db2 SQL applications to access remote non-Db2 REST-based services through SQL statements. Do not confuse them with Db2 native REST services, which supports using a REST-based interface to interact with Db2 data from web, mobile, and cloud applications.

```
BASE64ENCODE (text)
BASE64DECODE (text)
```

The schema is DB2XML.

text

Specifies the text to encode or decode. For BASE64ENCODE, this argument is provided as a VARCHAR(2732) value and the function returns a Base64-encoded string. For BASE64DECODE, this argument is provided as a Base64-encoded VARCHAR(4096) value and the function returns the data as binary.

Related tasks

[Creating REST user-defined functions \(Db2 Installation and Migration\)](#)

CURRENCY

The CURRENCY function returns a value that is formatted as an amount with a user-specified currency symbol and, if specified, one of three symbols that indicate debit or credit.

```
CURRENCY( input-amount, currency-symbol, credit/debit-indicator )
```

The schema is DSN8.

input-amount

An expression that specifies the value to be formatted. The expression must be a floating-point value.

currency-symbol

A character string that specifies the currency symbol. The string must have a data type of VARCHAR and an actual length that is not greater than 2 bytes.

credit/debit-indicator

A character string that specifies the symbol that is included with the result to indicate whether the value is negative or positive. The string must have a data type of VARCHAR and an actual length that is not greater than 5 bytes. If *credit/debit-indicator* is not specified or is the value null, the result is formatted without an indicator symbol. You can specify the following symbols:

CR/DB

Bank style. Negative input values are appended with 'DB'; positive input values are appended with 'CR'.

+/-

Arithmetic style. Negative input values are prefixed with a minus sign '-'; positive values are formatted without symbols.

()

Accounting style. Negative input values are enclosed in parentheses '()'; positive values are formatted without symbols.

The result of the function is VARCHAR(19).

The CURRENCY function uses the C language functions `strfmon` to facilitate formatting of money amounts and `setlocale` to initialize `strfmon` for local conventions. If `setlocale` fails, the CURRENCY function returns an error.

The following table shows the external program and specific names for CURRENCY. The specific names differ depending on the input to the function.

Table 429. External program and specific names for CURRENCY

Input arguments	External name	Specific name
<i>input-amount</i> <i>currency-symbol</i>	DSN8DUCY	DSN8.DSN8DUCYFV
<i>input-amount</i> <i>currency-symbol</i> <i>credit/debit-indicator</i>	DSN8DUCY	DSN8.DSN8DUCYFVV

Example 1: Express `'-1234.56'` as an amount in US dollars, using the bank style debit/credit indicator to indicate whether the value is negative or positive.

```
VALUES DSN8.CURRENCY( -1234.56, '$', 'CR/DB' );
```

The result of the function is `'$1,234.56 DB'`.

Example 2: Express `'-1234.56'` as an amount in Deutsche marks, using the accounting style debit/credit indicator to indicate whether the value is negative or positive.

```
VALUES DSN8.CURRENCY( -1234.56, 'DM', '( / )' );
```

The result of the function is `'(DM 1,234.56)'`.

Example 3: Express `'-1234.56'` as an amount in Canadian dollars, using the accounting style debit/credit indicator to indicate whether the value is negative or positive.

```
VALUES DSN8.CURRENCY( -1234.56, 'CD', '+ / - ' );
```

The result of the function is `'-CD 1,234.56'`.

DAYNAME

The DAYNAME function returns the name of the weekday on which a given date falls. The name is returned in English.

```
►► DAYNAME( input-date ) ◄◄
```

The schema is DSN8.

input-date

A valid date or valid character string representation of a date. A character string representation The string must have a data type of VARCHAR and an actual length that is not greater than 10 bytes. The date must be in ISO format.

The result of the function is VARCHAR(9).

The DAYNAME function uses the IBM C++ class `IDate`.

The following table shows the external and specific names for DAYNAME. The specific names differ depending on the data type of the input argument.

Table 430. External and specific names for DAYNAME

Input arguments	External name	Specific name
<i>input-date</i> (VARCHAR)	DSN8EUDN	DSN8.DSN8EUDNV
<i>input-date</i> (DATE)	DSN8EUDN	DSN8.DSN8EUDND

Example 1: For the current date, find the day of the week.

```
VALUES DSN8.DAYNAME( CURRENT DATE );
```

Example 2: Find the day of the week on which leap year falls in the year 2008.

```
VALUES DSN8.DAYNAME( '2008-02-29' );
```

The result of the function is 'Friday'.

Example 3: Find the day of the week on which Delores Quintana, employee number 000130, was hired.

```
SELECT FIRSTNAME || ' '
      || LASTNAME || ' was hired on '
      || DSN8.DAYNAME( HIREDATE ) || ', '
      || CHAR( HIREDATE )
FROM EMP
WHERE EMPNO = '000130';
```

The result of the function is 'DELORES QUINTANA was hired on Wednesday, 1971-07-28'.

HDFS_READ

The HDFS_READ function reads data from a delimiter-separated file in the Hadoop Distributed File System (HDFS).

► HDFS_READ(*file-url*, *options*) ◄

The schema is SYSFUN.

file-url

An expression that specifies the server address and path of the input file in HDFS. *file-url* is a VARCHAR(512) value.

options

An expression that specifies a list of *name=value* pairs. Each pair must be separated from the following pair by a space character. *options* is a VARCHAR(256) value. *options* can contain any of the following name and value pairs:

delimiter=delimiter-value

Identifies the character that is used as the delimiter in the input file that is specified by *file-url*.

user=user-value

Specifies an IBM InfoSphere® BigInsights® user name that has access to the input file that is specified by *file-url*.

password=password-value

Specifies the password for the IBM InfoSphere BigInsights user that is identified by *user=user-value*.

authport=authport-value

Specifies the port for form-based authentication of the input. The default is 8080.

The HDFS_READ function returns a table with one row for each record in the input file. HDFS_READ is a generic table function, which means that the columns in the returned table are defined when the table is referenced, instead of when the table is defined.

Example 1: Read an HDFS file whose URL is `http://hdfssrv.svl.ibm.com:8080`. The input file delimiter is a comma. Use the default authorization port. The records in the input file have two fields: a DECIMAL(8,3) field, and an INTEGER field.

```
SELECT * FROM TABLE(  
  HDFS_READ(  
    'http://hdfssrv.svl.ibm.com:8080',  
    'delimiter=', user=biadmin password=passwd'  
  )  
  AS T1(C1 DECIMAL(8,3), C2 INTEGER);
```

Example 2: Read an HDFS file whose URL is the location to which the output of a successful Jaql query is written. That location is specified by the *return-string* parameter of the JAQL_SUBMIT invocation that submits the Jaql query.

```
SELECT * FROM TABLE(  
  HDFS_READ(  
    JAQL_SUBMIT(  
      '[[15.3, 16],[170.99,180]]->  
      write(del(location='/tmp/test1.csv')));',  
      'http://hdfssrv.svl.ibm.com:14000/webhdfs/v1/tmp/test1.csv',  
      'http://jaqlsrv.svl.ibm.com:8080',  
      'timeout=60 user=biadmin', password=passwd'  
    ),  
    'user=biadmin password=passwd'  
  )  
  AS T1(C1 DECIMAL(8,3), C2 INTEGER);
```

Related reference

JAQL_SUBMIT

The JAQL_SUBMIT function invokes an IBM InfoSphere BigInsights Jaql query from a Db2 application.

Related information

[Db2 11 for z/OS Technical Overview \(IBM Redbooks\)](#)

HTTPBLOB

The HTTPBLOB REST function completes an HTTP request with the specified HTTP verb. Response messages from the server are returned as BLOB data.

Tip: The sample HTTP user-defined functions are intended to be used within Db2 SQL applications to access remote non-Db2 REST-based services through SQL statements. Do not confuse them with Db2 native REST services, which supports using a REST-based interface to interact with Db2 data from web, mobile, and cloud applications.

►► HTTPBLOB (url,method, , ) ◀◀

The schema is DB2XML.

url

Specifies the URL at which to complete the request. This argument is defined as a VARCHAR(2048) value.

method

Specifies the HTTP verb to use. Valid values are GET, POST, PUT, and DELETE.

httpHeader

Specifies an optional header XML document. This argument is defined as a CLOB(10K) value.

url

Specifies the URL at which to complete the request. This argument is defined as a VARCHAR(2048) value.

method

Specifies the HTTP verb to use. Valid values are GET, POST, PUT, and DELETE.

httpHeader

Specifies an optional header XML document. This argument is defined as a CLOB(10K) value.

The XML header document can provide additional HTTP header values in the following format:

```
<httpHeader headerAttribute="headerAttributeValue">
  <header name="name" value="value" />
</httpHeader>
```

headerAttribute

Specify any of the following optional attributes:

connectTimeout

Specifies an integer value for the connection timeout threshold in milliseconds.

readTimeout

Specifies an integer value for the read timeout threshold in milliseconds.

followRedirects

Specifies whether redirects should be followed. This is a boolean value.

useCaches

Specifies whether caches should be used. This is a boolean value.

responseMsgFormat

Specifies the header attribute value `errorTagged`, to indicate that when the server returns an error message to the user-defined function, the user-defined function returns the following values to the caller:

- SQLCODE 0
- The error message from the server, in the following format:

```
<error httprc="{HTTP-status-code}">
  {error-message-returned-from-server}
</error>
```

headerAttributeValue

Specifies a value for the `headerAttribute`. Separate `headerAttribute` and `headerAttributeValue` combinations with single spaces.

name

The header name.

value

The header value.

<input>

Specifies the data to update at the specified URL. This argument is defined as CLOB(5M).

Related tasks

[Creating REST user-defined functions \(Db2 Installation and Migration\)](#)

HTTPDELETEBLOB and HTTPDELETECLOB

The HTTPDELETEBLOB and HTTPDELETECLOB REST functions delete a binary or text-based resource from the specified URL through an HTTP DELETE request. HTTPDELETEBLOB returns messages as BLOB

data. HTTPDELETECLOB returns messages as CLOB data. The character set is converted into the database code page if necessary.

Tip: The sample HTTP user-defined functions are intended to be used within Db2 SQL applications to access remote non-Db2 REST-based services through SQL statements. Do not confuse them with Db2 native REST services, which supports using a REST-based interface to interact with Db2 data from web, mobile, and cloud applications.

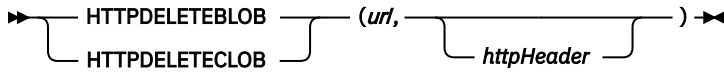

The schema is DB2XML.

url

Specifies the URL of the resource being accessed. This parameter is defined as a VARCHAR(2048) value.

httpHeader

Specifies an optional header XML document. This argument is defined as a CLOB(10K) value.

The XML header document can provide additional HTTP header values in the following format:

```
<httpHeader headerAttribute="headerAttributeValue">
  <header name="name" value="value" />
</httpHeader>
```

headerAttribute

Specify any of the following optional attributes:

connectTimeout

Specifies an integer value for the connection timeout threshold in milliseconds.

readTimeout

Specifies an integer value for the read timeout threshold in milliseconds.

followRedirects

Specifies whether redirects should be followed. This is a boolean value.

useCaches

Specifies whether caches should be used. This is a boolean value.

responseMsgFormat

Specifies the header attribute value `errorTagged`, to indicate that when the server returns an error message to the user-defined function, the user-defined function returns the following values to the caller:

- SQLCODE 0
- The error message from the server, in the following format:

```
<error httprc="{HTTP-status-code}">
  {error-message-returned-from-server}
</error>
```

headerAttributeValue

Specifies a value for the `headerAttribute`. Separate `headerAttribute` and `headerAttributeValue` combinations with single spaces.

name

The header name.

value

The header value.

Related tasks

[Creating REST user-defined functions \(Db2 Installation and Migration\)](#)

HTTPGETBLOB and HTTPGETCLOB

The HTTPGETBLOB and HTTPGETCLOB REST functions retrieve a binary or text-based resource from the specified URL through an HTTP GET request. HTTPGETBLOB returns the resource as BLOB(5M) data. HTTPGETCLOB returns the resource as CLOB(5M) data. The character set is converted into the database code page if necessary.

Tip: The sample HTTP user-defined functions are intended to be used within Db2 SQL applications to access remote non-Db2 REST-based services through SQL statements. Do not confuse them with Db2 native REST services, which supports using a REST-based interface to interact with Db2 data from web, mobile, and cloud applications.

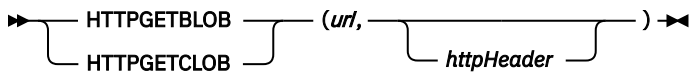

The schema is DB2XML.

url

Specifies the URL of the resource being accessed. This argument is defined as a VARCHAR(2048) value.

httpHeader

Specifies an optional header XML document. This argument is defined as a CLOB(10K) value.

The XML header document can provide additional HTTP header values in the following format:

```
<httpHeader headerAttribute="headerAttributeValue">
  <header name="name" value="value" />
</httpHeader>
```

headerAttribute

Specify any of the following optional attributes:

connectTimeout

Specifies an integer value for the connection timeout threshold in milliseconds.

readTimeout

Specifies an integer value for the read timeout threshold in milliseconds.

followRedirects

Specifies whether redirects should be followed. This is a boolean value.

useCaches

Specifies whether caches should be used. This is a boolean value.

responseMsgFormat

Specifies the header attribute value `errorTagged`, to indicate that when the server returns an error message to the user-defined function, the user-defined function returns the following values to the caller:

- SQLCODE 0
- The error message from the server, in the following format:

```
<error httprc="{HTTP-status-code}">
  {error-message-returned-from-server}
</error>
```

headerAttributeValue

Specifies a value for the `headerAttribute`. Separate `headerAttribute` and `headerAttributeValue` combinations with single spaces.

name

The header name.

value

The header value.

Examples

The examples in this section assume that the following requirements have been met:

- db2restudf.jar is defined in your CLASSPATH.
- The REST user-defined function (UDF) has been created.
- The server that is specified in the SQL statement is running.

In most cases, the results that are shown are truncated to include only the relevant parts of the output.

Example 1. The following SQL statement retrieves data from the www.ibm.com web page.

```
SELECT DB2XML.HTTPGETCLOB(
  CAST ('https://www.ibm.com' AS VARCHAR(2048)),
  CAST(NULL AS CLOB(1K)))
FROM SYSIBM.SYSDUMMY1
```

The output is similar to the following:

```
<!doctype html>
<html lang="en-US">
<head>
  <meta charset="UTF-8">
  <meta name="viewport" content="width=device-width"/>
  <meta charset="utf-8"/><title>IBM - United States</title>
  <link rel="canonical" href="https://www.ibm.com/us-en"/>
  <meta name="robots" content="index, follow"/>
  <meta name="description" content="For more than a century IBM has been dedicated ..."/>
  <meta name="keywords" content="IBM"/>
  ...
</html>
```

Example 2. The following SQL statement retrieves information that is in JSON format, about a book based on its ISBN identifier:

```
SELECT DB2XML.HTTPGETCLOB(
  CAST ('https://www.googleapis.com/books/v1/volumes?q=isbn:9781583478608' AS VARCHAR(255)),
  CAST(NULL AS CLOB(1K)))
FROM SYSIBM.SYSDUMMY1
```

The output is similar to the following:

```
{
  "kind": "books#volumes",
  "totalItems": 1,
  "items": [
    {
      "kind": "books#volume",
      "id": "7qGQvgAACAAJ",
      "etag": "qov9fok2EyI",
      "selfLink": "https://www.googleapis.com/books/v1/volumes/7qGQvgAACAAJ",
      "volumeInfo": {
        "title": "DB2 12 for Z/OS--The #1 Enterprise Database",
        "subtitle": "SECURE, SEAMLESS INTEGRATION for an Analytics, Mobile and Cloud World",
        "authors": [
          "Surekha Parekh"
        ],
        "publisher": "MC Press",
        "publishedDate": "2016-11-01",
        ...
      }
    }
  ]
}
```

Example 3. The following SQL statement retrieves information from the www.geonames.org web site. The results are in XML format.

```
SELECT DB2XML.HTTPGETCLOB(
  CAST('http://www.geonames.org/countryInfo?lang=' ||
```

```

DB2XML.URLENCODE('en','') ||
'&country=' ||
DB2XML.URLENCODE('us','') ||
'&type=XML' AS VARCHAR(255)),
CAST(NULL AS CLOB(1K))
FROM SYSIBM.SYSDUMMY1

```

This statement returns output that is similar to the following:

```

<?xml version="1.0" encoding="UTF-8" standalone="no"?>
<geonames>
  <country>
    <countryCode>US</countryCode>
    <countryName>United States</countryName>
    <isoNumeric>840</isoNumeric>
    <isoAlpha3>USA</isoAlpha3>
    <fipsCode>US</fipsCode>
    <continentName>North America</continentName>
    <capital>Washington</capital>
    <areaInSqKm>9629091.0</areaInSqKm>
    <population>327167434</population>
    <currencyCode>USD</currencyCode>
    <languages>en-US,es-US,haw,fr</languages>
    <geonameId>6252001</geonameId>
    <west>-124.733692</west>
    <north>49.384358</north>
    <east>-66.949607</east>
    <south>24.544093</south>
    <postalCodeFormat>#####-####</postalCodeFormat>
  </country>
</geonames>

```

Related tasks

[Creating REST user-defined functions \(Db2 Installation and Migration\)](#)

HTTPGETBLOBFILE and HTTPGETCLOBFILE

The HTTPGETBLOBFILE and HTTPGETCLOBFILE REST functions retrieve a binary or text-based resource from the specified URL through an HTTP GET request. The resource is stored in a temporary file, and the path of the temporary file is returned as VARCHAR data. The character set is converted into the database code page if necessary.

Tip: The sample HTTP user-defined functions are intended to be used within Db2 SQL applications to access remote non-Db2 REST-based services through SQL statements. Do not confuse them with Db2 native REST services, which supports using a REST-based interface to interact with Db2 data from web, mobile, and cloud applications.

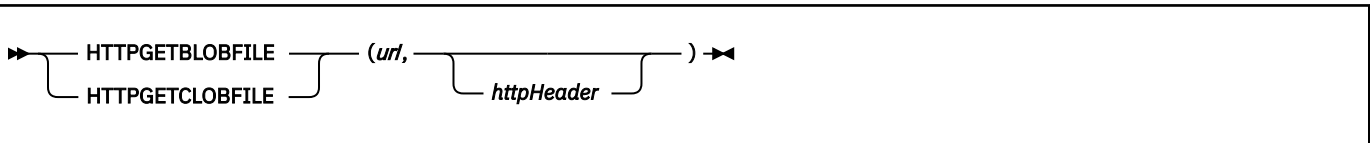

The schema is DB2XML.

url

Specifies the URL of the resource that is being accessed. This argument is defined as a VARCHAR(2048) value.

httpHeader

Specifies an optional header XML document. This argument is defined as a CLOB(10K) value.

The XML header document can provide additional HTTP header values in the following format:

```

<httpHeader headerAttribute="headerAttributeValue">
  <header name="name" value="value" />
</httpHeader>

```

headerAttribute

Specify any of the following optional attributes:

connectTimeout

Specifies an integer value for the connection timeout threshold in milliseconds.

readTimeout

Specifies an integer value for the read timeout threshold in milliseconds.

followRedirects

Specifies whether redirects should be followed. This is a boolean value.

useCaches

Specifies whether caches should be used. This is a boolean value.

responseMsgFormat

Specifies the header attribute value `errorTagged`, to indicate that when the server returns an error message to the user-defined function, the user-defined function returns the following values to the caller:

- SQLCODE 0
- The error message from the server, in the following format:

```
<error httprc="{HTTP-status-code}">
  {error-message-returned-from-server}
</error>
```

headerAttributeValue

Specifies a value for the `headerAttribute`. Separate `headerAttribute` and `headerAttributeValue` combinations with single spaces.

name

The header name.

value

The header value.

Related tasks

[Creating REST user-defined functions \(Db2 Installation and Migration\)](#)

HTTPHEAD

The HTTPHEAD REST function verifies the HTTP header for the specified resource through an HTTP HEAD request. The HTTP header is returned as CLOB or XML data.

Tip: The sample HTTP user-defined functions are intended to be used within Db2 SQL applications to access remote non-Db2 REST-based services through SQL statements. Do not confuse them with Db2 native REST services, which supports using a REST-based interface to interact with Db2 data from web, mobile, and cloud applications.

```
► HTTPHEAD (url, httpHeader) ►
```

The schema is DB2XML.

url

Specifies the URL of the resource. This argument is defined as a VARCHAR(2048) value.

httpHeader

Specifies an optional header XML document. This argument is defined as a CLOB(10K) value.

The XML header document can provide additional HTTP header values in the following format:

```
<httpHeader headerAttribute="headerAttributeValue">
  <header name="name" value="value" />
</httpHeader>
```

headerAttribute

Specify any of the following optional attributes:

connectTimeout

Specifies an integer value for the connection timeout threshold in milliseconds.

readTimeout

Specifies an integer value for the read timeout threshold in milliseconds.

followRedirects

Specifies whether redirects should be followed. This is a boolean value.

useCaches

Specifies whether caches should be used. This is a boolean value.

headerAttributeValue

Specifies a value for the *headerAttribute*. Separate *headerAttribute* and *headerAttributeValue* combinations with single spaces.

name

The header name.

value

The header value.

Related tasks

[Creating REST user-defined functions \(Db2 Installation and Migration\)](#)

HTTPPOSTBLOB and HTTPPOSTCLOB

The HTTPPOSTBLOB and HTTPPOSTCLOB REST functions update a binary or text-based resource under the specified URL through an HTTP POST request. Response messages from the server are returned as BLOB for HTTPPOSTBLOB or as CLOB for HTTPPOSTCLOB. The character set is converted into the database code page if necessary.

Tip: The sample HTTP user-defined functions are intended to be used within Db2 SQL applications to access remote non-Db2 REST-based services through SQL statements. Do not confuse them with Db2 native REST services, which supports using a REST-based interface to interact with Db2 data from web, mobile, and cloud applications.

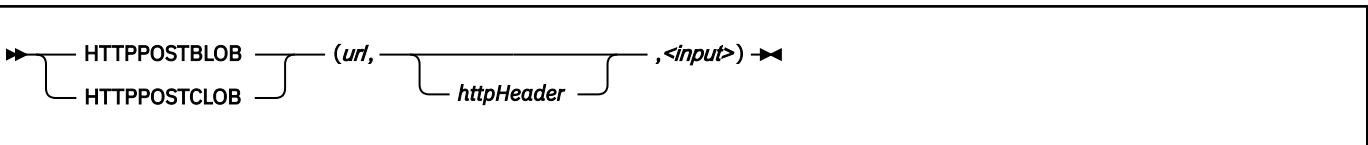

The schema is DB2XML.

url

Specifies the URL at which to update the data. This argument is defined as a VARCHAR(2048) value.

httpHeader

Specifies an optional header XML document. This argument is defined as a CLOB(10K) value.

The XML header document can provide additional HTTP header values in the following format:

```
<httpHeader headerAttribute="headerAttributeValue">
  <header name="name" value="value" />
</httpHeader>
```

headerAttribute

Specify any of the following optional attributes:

connectTimeout

Specifies an integer value for the connection timeout threshold in milliseconds.

readTimeout

Specifies an integer value for the read timeout threshold in milliseconds.

followRedirects

Specifies whether redirects should be followed. This is a boolean value.

useCaches

Specifies whether caches should be used. This is a boolean value.

responseMsgFormat

Specifies the header attribute value `errorTagged`, to indicate that when the server returns an error message to the user-defined function, the user-defined function returns the following values to the caller:

- SQLCODE 0
- The error message from the server, in the following format:

```
<error httprc="{HTTP-status-code}">
  {error-message-returned-from-server}
</error>
```

headerAttributeValue

Specifies a value for the `headerAttribute`. Separate `headerAttribute` and `headerAttributeValue` combinations with single spaces.

name

The header name.

value

The header value.

<input>

Specifies the data to update at the specified URL. This argument is defined as BLOB(5M) for HTTPPOSTBLOB or CLOB(5M) for HTTPPOSTCLOB.

Related tasks

[Creating REST user-defined functions \(Db2 Installation and Migration\)](#)

HTTPPUTBLOB and HTTPPUTCLOB

The HTTPPUTBLOB and HTTPPUTCLOB REST functions create or update a binary or text-based resource under the specified URL through an HTTP PUT request. Response messages from the server are returned as BLOB for HTTPPUTBLOB or as CLOB for HTTPPUTCLOB. The character set is converted into the database code page if necessary.

Tip: The sample HTTP user-defined functions are intended to be used within Db2 SQL applications to access remote non-Db2 REST-based services through SQL statements. Do not confuse them with Db2 native REST services, which supports using a REST-based interface to interact with Db2 data from web, mobile, and cloud applications.

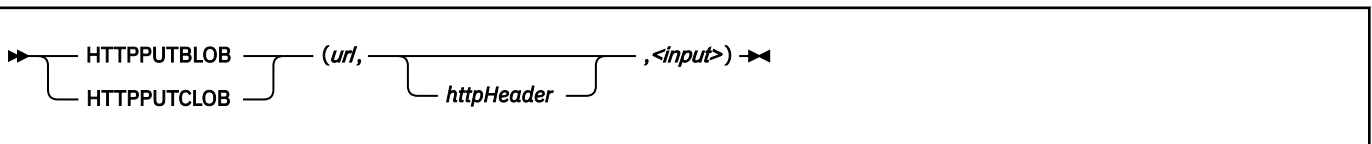

The schema is DB2XML.

url

Specifies the URL at which to create or update the data. This argument is defined as a VARCHAR(2048) value.

httpHeader

Specifies an optional header XML document. This argument is defined as a CLOB(10K) value.

The XML header document can provide additional HTTP header values in the following format:

```
<httpHeader headerAttribute="headerAttributeValue">
  <header name="name" value="value" />
</httpHeader>
```

headerAttribute

Specify any of the following optional attributes:

connectTimeout

Specifies an integer value for the connection timeout threshold in milliseconds.

readTimeout

Specifies an integer value for the read timeout threshold in milliseconds.

followRedirects

Specifies whether redirects should be followed. This is a boolean value.

useCaches

Specifies whether caches should be used. This is a boolean value.

responseMsgFormat

Specifies the header attribute value `errorTagged`, to indicate that when the server returns an error message to the user-defined function, the user-defined function returns the following values to the caller:

- SQLCODE 0
- The error message from the server, in the following format:

```
<error httprc="{HTTP-status-code}">
  {error-message-returned-from-server}
</error>
```

headerAttributeValue

Specifies a value for the `headerAttribute`. Separate `headerAttribute` and `headerAttributeValue` combinations with single spaces.

name

The header name.

value

The header value.

<input>

Specifies the data to create or update at the specified URL. This argument is defined as BLOB(5M) for HTTPPUTBLOB or CLOB(5M) for HTTPPUTCLOB.

Related tasks

[Creating REST user-defined functions \(Db2 Installation and Migration\)](#)

JAQL_SUBMIT

The JAQL_SUBMIT function invokes an IBM InfoSphere BigInsights Jaql query from a Db2 application.

```
►► JAQL_SUBMIT( jaql-script ,return-string ,url,options ) ◄◄
```

The schema is SYSFUN.

jaql-script

Specifies a script that contains one or more Jaql queries, with or without parameter declarations. `jaql-script` is a VARCHAR(8000) value.

return-string

Specifies a string that is used as the returned value when the Jaql script completes successfully. `return-string` is a VARCHAR(512) value.

url

Specifies the URL of a Jaql server that accepts requests from the Db2 client, runs the queries that are specified in *jaql-script*, and returns results. *url* is a VARCHAR(512) value.

options

An expression that specifies a list of *name=value* pairs. Each pair must be separated from the following pair by a space character. *options* is a VARCHAR(256) value. *options* can contain any of the following name and value pairs:

timeout=timeout-value

Specifies the maximum time in seconds to wait for results to be returned from the Jaql server that is specified in the *url* parameter.

user=user-value

Specifies an IBM InfoSphere BigInsights user name that has access to the Jaql server.

password=password-value

Specifies the password for the IBM InfoSphere BigInsights user that is identified by *user=user-value*.

The JAQL_SUBMIT function returns a VARCHAR(512) string that contains the results of executing the Jaql script.

Example 1: Submit a Jaql script to a Jaql server. The Jaql script writes an array to a file, in delimited format. The URL of the Jaql server is <http://jaqlsrv.svl.ibm.com:8080>. Do not specify the string that is to be returned if the script completes successfully. Wait for a maximum of 60 seconds for output to be returned.

```
SELECT SYSFUN.JAQL_SUBMIT(
  '[[15.3, 16],[170.99,180]]->
  write(del(location='/tmp/test1.csv'));',
  'http://jaqlsrv.svl.ibm.com:8080',
  'timeout=60 user=biadmin password=passwd')
FROM SYSIBM.SYSDUMMY1;
```

Related information

[Db2 11 for z/OS Technical Overview \(IBM Redbooks\)](#)

MONTHNAME

The MONTHNAME function returns the calendar name of the month in which a given date falls. The name is returned in English.

►► MONTHNAME(*input-date*) ◄◄

The schema is DSN8.

input-date

A valid date or valid character string representation of a date. A character string representation must have a data type of VARCHAR and an actual length that is no greater than 10 bytes. The date must be in ISO format.

The result of the function is VARCHAR(9).

The MONTHNAME function uses the IBM C++ class IDate.

The following table shows the external and specific names for MONTHNAME. The specific names differ depending on the data type of the input argument.

Table 431. External and specific names for MONTHNAME

Input arguments	External name	Specific name
<i>input-date</i> (VARCHAR)	DSN8EUMN	DSN8.DSN8EUMNV
<i>input-date</i> (DATE)	DSN8EUMN	DSN8.DSN8EUMND

Example 1: For the current date, find the name of the month.

```
VALUES DSN8.MONTHNAME( CURRENT DATE );
```

Example 2: Find the month of the year in which Delores Quintana, employee number 000130, was hired.

```
SELECT FIRSTNAME || ' '
      || LASTNAME || ' was hired in the month of '
      || DSN8.MONTHNAME( HIREDATE )
      || CHAR( HIREDATE )
FROM EMP
WHERE EMPNO = '000130';
```

The result of the function is 'DELORES QUINTANA was hired in the month of July'.

TABLE_LOCATION

The TABLE_LOCATION function searches for an object and returns the location name of the object after any alias chains have been resolved.

```
► TABLE_LOCATION( — object-name — , object-schema — , location-name — ) ◄
```

The schema is DSN8.

The starting point of the resolution is the object that is specified by *object-name* and, if specified, *object-schema* and *location-name*. If the starting point does not refer to an alias, the location name of the starting point is returned. The resulting name can be of a table, view, or undefined object. The function returns a blank if there is no location name.

object-name

A character expression that specifies the unqualified name to be resolved. The unqualified name is usually of an existing alias. *object-name* must have a data type of VARCHAR and an actual length that is no greater than 18 bytes.

object-schema

A character expression that represents the schema that is used to qualify the value specified in *object-name* before resolution. *object-schema* must have a data type of VARCHAR and an actual length that is no greater than 8 bytes.

If *object-schema* is not specified or is null, the default schema is used for the qualifier.

location-name

A character expression that represents the location that is used to qualify the value specified in *object-name* before resolution. *location-name* must have a data type of VARCHAR and an actual length that is no greater than 16 bytes.

If *location-name* is not specified or is null, the location name is equivalent to "any".

The result of the function is VARCHAR(16). If *object-name* can be null, the result can be null; if *object-name* is null, the result is the null value.

The following table shows the external and specific names for TABLE_LOCATION. The specific names differ depending on the number of input arguments to the function.

Table 432. External and specific names for TABLE_LOCATION

Input arguments	External name	Specific name
<i>object-name</i> (VARCHAR)	DSN8DUTI	DSN8.DSN8DUTILV
<i>object-name</i> (VARCHAR) <i>object-schema</i> (VARCHAR)	DSN8DUTI	DSN8.DSN8DUTILVV
<i>object-name</i> (VARCHAR) <i>object-schema</i> (VARCHAR) <i>location-name</i> (VARCHAR)	DSN8DUTI	DSN8.DSN8DUTILVVV

Example: Assume that:

- DSN8.ALIAS_RS_SYSTABLES is an alias of SYSIBM.SYSTABLES at location name 'REMOTE_SITE'.
- The CURRENT SQLID is DSN8.

Use TABLE_LOCATION to find the location name where the base object for ALIAS_RS_SYSTABLES resides.

```
VALUES DSN8.TABLE_LOCATION( 'ALIAS_RS_SYSTABLES' );
```

The result of the function is 'REMOTE_SITE'.

TABLE_NAME

The TABLE_NAME function searches for an object and returns the unqualified name of the object after any alias chains have been resolved.

►► TABLE_NAME(— *object-name* — , *object-schema* — , *location-name* —) ◀◀

The schema is DSN8.

The starting point of the resolution is the object that is specified by *object-name* and, if specified, *object-schema* and *location name*. If the starting point does not refer to an alias, the unqualified name of the starting point is returned. The resulting name can be of a table, view, or undefined object.

object-name

A character expression that specifies the unqualified name to be resolved. The unqualified name is usually of an existing alias. *object-name* must have a data type of VARCHAR and an actual length that is no greater than 18 bytes.

object-schema

A character expression that represents the schema that is used to qualify the value specified in *object-name* before resolution. *object-schema* must have a data type of VARCHAR and an actual length that is no greater than 8 bytes.

If *object-schema* is not specified or is null, the default schema is used for the qualifier.

location-name

A character expression that represents the location that is used to qualify the value specified in *object-name* before resolution. *location-name* must have a data type of VARCHAR and an actual length that is no greater than 16 bytes.

If *location-name* is not specified or is null, the location name is equivalent to "any".

The result of the function is VARCHAR(128). If *object-name* can be null, the result can be null; if *object-name* is null, the result is the null value.

The following table shows the external and specific names for TABLE_NAME. The specific names differ depending on the number of input arguments to the function.

Table 433. External and specific names for TABLE_NAME

Input arguments	External name	Specific name
<i>object-name</i> (VARCHAR)	DSN8DUTI	DSN8.DSN8DUTINV
<i>object-name</i> (VARCHAR) <i>object-schema</i> (VARCHAR)	DSN8DUTI	DSN8.DSN8DUTINVV
<i>object-name</i> (VARCHAR) <i>object-schema</i> (VARCHAR) <i>location-name</i> (VARCHAR)	DSN8DUTI	DSN8.DSN8DUTINVVV

Example: Assume that:

- DSN8.VIEW_OF_SYSTABLES is a view of SYSIBM.SYSTABLES.
- DSN8.ALIAS_OF_VIEW is an alias of DSN8.VIEW_OF_SYSTABLES.
- The CURRENT SQLID is DSN8.

Use TABLE_NAME to find the name of the base object for ALIAS_OF_VIEW.

```
VALUES DSN8.TABLE_NAME( 'ALIAS_OF_VIEW' );
```

The result of the function is 'VIEW_OF_SYSTABLES'.

TABLE_SCHEMA

The TABLE_SCHEMA function searches for an object and returns the schema name of the object after any synonyms or alias chains have been resolved.

```
▶▶ TABLE_SCHEMA( — object-name ————— ) ▶▶  
                   , object-schema —————  
                   , location-name —————
```

The schema is DSN8.

The starting point of the resolution is the object that is specified by *objectname* and *objectschema*. If the starting point does not refer to an alias or synonym, the schema name of the starting point is returned. The resulting schema name can be of a table, view, or undefined object.

object-name

A character expression that specifies the unqualified name to be resolved. The unqualified name is usually of an existing alias. *object-name* must have a data type of VARCHAR and an actual length that is no greater than 18 bytes.

object-schema

A character expression that represents the schema that is used to qualify the value specified in *object-name* before resolution. *object-schema* must have a data type of VARCHAR and an actual length that is no greater than 8 bytes.

If *object-schema* is not specified or is null, the default schema is used for the qualifier.

location-name

A character expression that represents the location that is used to qualify the value specified in *object-name* before resolution. *location-name* must have a data type of VARCHAR (and an actual length that is no greater than 16 bytes).

If *location-name* is not specified or is null, the location name is equivalent to "any".

The result of the function is VARCHAR(128). If *object-name* can be null, the result can be null; if *object-name* is null, the result is the null value.

The following table shows the external and specific names for TABLE_SCHEMA. The specific names differ depending on the number of input arguments.

Table 434. External and specific names for function TABLE_SCHEMA

Input arguments	External name	Specific name
<i>object-name</i> (VARCHAR)	DSN8DUTI	DSN8.DSN8DUTISV
<i>object-name</i> (VARCHAR) <i>object-schema</i> (VARCHAR)	DSN8DUTI	DSN8.DSN8DUTISVV
<i>object-name</i> (VARCHAR) <i>object-schema</i> (VARCHAR) <i>location-name</i> (VARCHAR)	DSN8DUTI	DSN8.DSN8DUTISVVV

Example: Assume that:

- DSN8.ALIAS_OF_SYSTABLES is an alias of SYSIBM.SYSTABLES.
- The CURRENT SQLID is DSN8.

Find the name of the schema of the base table for ALIAS_OF_SYSTABLES.

```
VALUES DSN8.TABLE_SCHEMA( 'ALIAS_OF_SYSTABLES' );
```

The result of the function is 'SYSIBM'.

URLENCODE and URLDECODE

The URLENCODE and URLDECODE helper REST functions complete URL encoding or decoding of the provided text.

Tip: The sample HTTP user-defined functions are intended to be used within Db2 SQL applications to access remote non-Db2 REST-based services through SQL statements. Do not confuse them with Db2 native REST services, which supports using a REST-based interface to interact with Db2 data from web, mobile, and cloud applications.

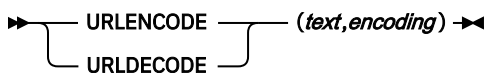

The schema is DB2XML.

text

Specifies the text to encode or decode. This argument is defined as a VARCHAR(2048) value.

encoding

Specifies the character set that is to be used. It can be set to NULL where UTF-8 is used as the default.

Related tasks

Creating REST user-defined functions (Db2 Installation and Migration)

WEATHER

The WEATHER function returns information from a TSO data set as a Db2 table. The TSO data set contains sample weather statistics for various cities in the United States. The statistics are returned to the client with a row for each city and a column for each statistic. The WEATHER function is provided primarily to help you design and implement table functions.

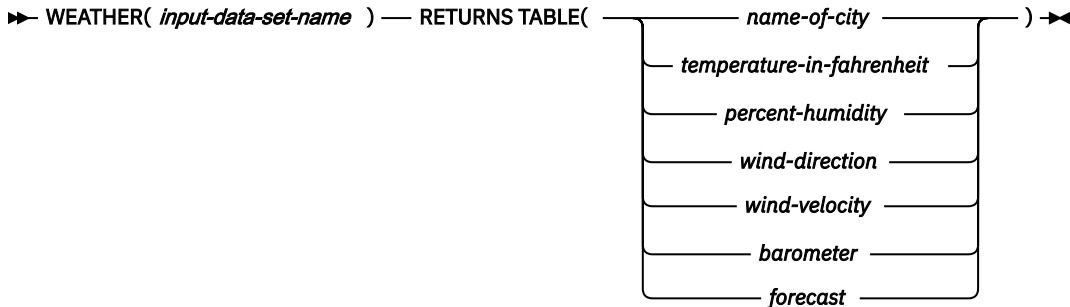

The schema is DSN8.

Unlike the other sample user-defined functions, which are scalar functions, WEATHER is a table function. WEATHER shows how to use a table function to make non-relational data available to a client for manipulation by SQL.

input-data-set-name

The name of the TSO data set that contains sample weather statistics. The name is a character string with a data type of VARCHAR and an actual length that is not greater than 44 bytes.

The result of the function is a Db2 table with the following columns. Each column can be null.

name-of-city

VARCHAR(30)

temperature-in-fahrenheit

INTEGER

percent-humidity

INTEGER

wind-direction

VARCHAR(5)

wind-velocity

INTEGER

barometer

FLOAT

forecast

VARCHAR(25)

The external program name for the function is DSN8DUWF, and the specific name is DSN8.DSN8DUWF.

Example: Find the name of and the forecast for the cities that have a temperature less than 25 degrees.

```
SELECT CITY, FORECAST
FROM TABLE(DSN8.WEATHER('prefix.SDSNIVPD(DSN8LWC)')) AS W
WHERE TEMP_IN_F < 25
ORDER BY CITY;
```

This example returns:

Bessemer, MI	Slight chance of snow
Cheyenne, WY	Continued cooling
Helena, MT	Heavy snow
Pierre, SD	Continued cold

Information resources for Db2 for z/OS and related products

You can find the online product documentation for Db2 12 for z/OS and related products in IBM Documentation.

For all online product documentation for Db2 12 for z/OS, see [IBM Documentation \(https://www.ibm.com/docs/en/db2-for-zos/12\)](https://www.ibm.com/docs/en/db2-for-zos/12).

For other PDF manuals, see [PDF format manuals for Db2 12 for z/OS \(https://www.ibm.com/docs/en/db2-for-zos/12?topic=zos-pdf-format-manuals-db2-12\)](https://www.ibm.com/docs/en/db2-for-zos/12?topic=zos-pdf-format-manuals-db2-12).

Notices

This information was developed for products and services offered in the US. This material might be available from IBM in other languages. However, you may be required to own a copy of the product or product version in that language in order to access it.

IBM may not offer the products, services, or features discussed in this document in other countries. Consult your local IBM representative for information on the products and services currently available in your area. Any reference to an IBM product, program, or service is not intended to state or imply that only that IBM product, program, or service may be used. Any functionally equivalent product, program, or service that does not infringe any IBM intellectual property right may be used instead. However, it is the user's responsibility to evaluate and verify the operation of any non-IBM product, program, or service.

IBM may have patents or pending patent applications covering subject matter described in this document. The furnishing of this document does not give you any license to these patents. You can send license inquiries, in writing, to:

*IBM Director of Licensing IBM Corporation
North Castle Drive, MD-NC119
Armonk, NY 10504-1785 US*

For license inquiries regarding double-byte (DBCS) information, contact the IBM Intellectual Property Department in your country or send inquiries, in writing, to:

*Intellectual Property Licensing Legal and Intellectual Property Law IBM Japan Ltd.
19-21, Nihonbashi-Hakozakicho, Chuo-ku
Tokyo 103-8510, Japan*

INTERNATIONAL BUSINESS MACHINES CORPORATION PROVIDES THIS PUBLICATION "AS IS" WITHOUT WARRANTY OF ANY KIND, EITHER EXPRESS OR IMPLIED, INCLUDING, BUT NOT LIMITED TO, THE IMPLIED WARRANTIES OF NON-INFRINGEMENT, MERCHANTABILITY OR FITNESS FOR A PARTICULAR PURPOSE. Some jurisdictions do not allow disclaimer of express or implied warranties in certain transactions, therefore, this statement may not apply to you.

This information could include technical inaccuracies or typographical errors. Changes are periodically made to the information herein; these changes will be incorporated in new editions of the publication. IBM may make improvements and/or changes in the product(s) and/or the program(s) described in this publication at any time without notice.

Any references in this information to non-IBM websites are provided for convenience only and do not in any manner serve as an endorsement of those websites. The materials at those websites are not part of the materials for this IBM product and use of those websites is at your own risk.

IBM may use or distribute any of the information you supply in any way it believes appropriate without incurring any obligation to you.

Licenseses of this program who wish to have information about it for the purpose of enabling: (i) the exchange of information between independently created programs and other programs (including this one) and (ii) the mutual use of the information which has been exchanged, should contact:

*IBM Director of Licensing IBM Corporation
North Castle Drive, MD-NC119
Armonk, NY 10504-1785 US*

Such information may be available, subject to appropriate terms and conditions, including in some cases, payment of a fee.

The licensed program described in this document and all licensed material available for it are provided by IBM under terms of the IBM Customer Agreement, IBM International Program License Agreement or any equivalent agreement between us.

This information contains examples of data and reports used in daily business operations. To illustrate them as completely as possible, the examples include the names of individuals, companies, brands, and products. All of these names are fictitious and any similarity to actual people or business enterprises is entirely coincidental.

COPYRIGHT LICENSE:

This information contains sample application programs in source language, which illustrate programming techniques on various operating platforms. You may copy, modify, and distribute these sample programs in any form without payment to IBM, for the purposes of developing, using, marketing or distributing application programs conforming to the application programming interface for the operating platform for which the sample programs are written. These examples have not been thoroughly tested under all conditions. IBM, therefore, cannot guarantee or imply reliability, serviceability, or function of these programs. The sample programs are provided "AS IS", without warranty of any kind. IBM shall not be liable for any damages arising out of your use of the sample programs.

Each copy or any portion of these sample programs or any derivative work must include a copyright notice as shown below:

© (your company name) (year).

Portions of this code are derived from IBM Corp. Sample Programs.

© Copyright IBM Corp. (enter the year or years).

If you are viewing this information softcopy, the photographs and color illustrations may not appear.

Programming interface information

This information is intended to help you to code SQL statements. This information primarily documents General-use Programming Interface and Associated Guidance Information provided by Db2 12 for z/OS. This information also documents Product-sensitive Programming Interface and Associated Guidance Information provided by Db2 12 for z/OS.



General-use Programming Interface and Associated Guidance Information

General-use Programming Interfaces allow the customer to write programs that obtain the services of Db2 12 for z/OS.

Product-sensitive Programming Interface and Associated Guidance Information

Product-sensitive Programming Interfaces allow the customer installation to perform tasks such as diagnosing, modifying, monitoring, repairing, tailoring, or tuning of this IBM software product. Use of such interfaces creates dependencies on the detailed design or implementation of the IBM software product. Product-sensitive Programming Interfaces should be used only for these specialized purposes. Because of their dependencies on detailed design and implementation, it is to be expected that programs written to such interfaces may need to be changed in order to run with new product releases or versions, or as a result of service.

Product-sensitive Programming Interface and Associated Guidance Information is identified where it occurs by the following markings:

 Product-sensitive Programming Interface and Associated Guidance Information... 

Trademarks

IBM, the IBM logo, and [ibm.com](http://www.ibm.com)® are trademarks or registered marks of International Business Machines Corp., registered in many jurisdictions worldwide. Other product and service names might be trademarks of IBM or other companies. A current list of IBM trademarks is available on the web at "Copyright and trademark information" at: <http://www.ibm.com/legal/copytrade.shtml>.

Linux is a registered trademark of Linus Torvalds in the United States, other countries, or both.

Microsoft, Windows, Windows NT, and the Windows logo are trademarks of Microsoft Corporation in the United States, other countries, or both.

UNIX is a registered trademark of The Open Group in the United States and other countries.

Java and all Java-based trademarks and logos are trademarks or registered trademarks of Oracle and/or its affiliates.

Terms and conditions for product documentation

Permissions for the use of these publications are granted subject to the following terms and conditions:

Applicability: These terms and conditions are in addition to any terms of use for the IBM website.

Personal use: You may reproduce these publications for your personal, noncommercial use provided that all proprietary notices are preserved. You may not distribute, display or make derivative work of these publications, or any portion thereof, without the express consent of IBM.

Commercial use: You may reproduce, distribute and display these publications solely within your enterprise provided that all proprietary notices are preserved. You may not make derivative works of these publications, or reproduce, distribute or display these publications or any portion thereof outside your enterprise, without the express consent of IBM.

Rights: Except as expressly granted in this permission, no other permissions, licenses or rights are granted, either express or implied, to the publications or any information, data, software or other intellectual property contained therein.

IBM reserves the right to withdraw the permissions granted herein whenever, in its discretion, the use of the publications is detrimental to its interest or, as determined by IBM, the above instructions are not being properly followed.

You may not download, export or re-export this information except in full compliance with all applicable laws and regulations, including all United States export laws and regulations.

IBM MAKES NO GUARANTEE ABOUT THE CONTENT OF THESE PUBLICATIONS. THE PUBLICATIONS ARE PROVIDED "AS-IS" AND WITHOUT WARRANTY OF ANY KIND, EITHER EXPRESSED OR IMPLIED, INCLUDING BUT NOT LIMITED TO IMPLIED WARRANTIES OF MERCHANTABILITY, NON-INFRINGEMENT, AND FITNESS FOR A PARTICULAR PURPOSE.

Privacy policy considerations

IBM Software products, including software as a service solutions, (“Software Offerings”) may use cookies or other technologies to collect product usage information, to help improve the end user experience, to tailor interactions with the end user, or for other purposes. In many cases no personally identifiable information is collected by the Software Offerings. Some of our Software Offerings can help enable you to collect personally identifiable information. If this Software Offering uses cookies to collect personally identifiable information, specific information about this offering’s use of cookies is set forth below.

This Software Offering does not use cookies or other technologies to collect personally identifiable information.

If the configurations deployed for this Software Offering provide you as customer the ability to collect personally identifiable information from end users via cookies and other technologies, you should seek your own legal advice about any laws applicable to such data collection, including any requirements for notice and consent.

For more information about the use of various technologies, including cookies, for these purposes, see IBM’s Privacy Policy at <http://www.ibm.com/privacy> and IBM’s Online Privacy Statement at <http://www.ibm.com/privacy/details> the section entitled “Cookies, Web Beacons and Other Technologies” and the “IBM Software Products and Software-as-a-Service Privacy Statement” at <http://www.ibm.com/software/info/product-privacy>.

Glossary

The glossary is available in IBM Documentation

For definitions of Db2 for z/OS terms, see [Db2 glossary \(Db2 Glossary\)](#).

Index

Special Characters

- [_ \(underscore character\) as escape character 308](#)
- [- \(minus sign\) 250](#)
- [, \(comma\) as decimal point 323](#)
- [: \(colon\)](#)
 - [preceding a host variable 227](#)
- [! \(exclamation mark\) as not sign 297](#)
- [? \(question mark\) 1910](#)
- [. \(period\) as decimal point 323](#)
- [* \(asterisk\)](#)
 - [COUNT function 353](#)
 - [COUNT_BIG function 353](#)
 - [multiply sign 250](#)
 - [use in subselect 1011](#)
- [/ \(divide sign\) 250](#)
- [% \(percent sign\) as escape character 308](#)
- [+ \(plus sign\) 250](#)
- [+ \(plus sign\) as escape character 308](#)
- [|| \(vertical bars\) 247](#)

A

- [ABS function 382](#)
- [ABSOLUTE clause](#)
 - [FETCH statement 1930](#)
- [ABSVAL function 382](#)
- [accelerator tables](#)
 - [SYSACCELERATEDPACKAGES 2934](#)
 - [SYSACCELERATEDTABLES 2932](#)
 - [SYSACCELERATEDTABLESAUTH 2934](#)
 - [SYSACCELERATORS 2931](#)
- [accelerators tables](#)
 - [indexes 2931](#)
 - [table space 2931](#)
- [ACCESSCTRL privilege](#)
 - [GRANT statement 1983](#)
 - [REVOKE statement 2097](#)
- [accessibility](#)
 - [keyboard xxv](#)
 - [shortcut keys xxv](#)
- [ACCESSPATH column](#)
 - [SYSPACKSTMT catalog table 2558](#)
 - [SYSSTMT catalog table 2651](#)
- [ACOS function 383](#)
- [ACQUIRE](#)
 - [column of SYSPLAN catalog table 2575](#)
- [ACTION column](#)
 - [SYSINDEXCONTROL catalog table 2460](#)
- [ACTIVATE VERSION clause](#)
 - [ALTER PROCEDURE \(SQL - native\) statement 1201](#)
- [ACTIVE column](#)
 - [SYSROUTINES catalog table 2621](#)
- [active logs 40](#)
- [ACTIVE VERSION clause](#)
 - [ALTER PROCEDURE \(SQL - native\) statement 1200](#)
- [ADD ATTRIBUTES clause](#)
 - [ALTER TRUSTED CONTEXT statement 1372](#)
- [ADD clause](#)
 - [ALTER TABLE statement 1246](#)
- [ADD CLONE clause](#)
 - [ALTER TABLE statement 1289](#)
- [ADD COLUMN clause](#)
 - [ALTER INDEX statement 1168](#)
- [ADD MATERIALIZED QUERY clause](#)
 - [ALTER TABLE statement 1285](#)
- [ADD ORGANIZE BY HASH clause](#)
 - [ALTER TABLE statement 1312](#)
- [ADD PARTITION clause](#)
 - [ALTER TABLE statement 1276](#)
- [ADD RESTRICT ON DROP clause](#)
 - [ALTER TABLE statement 1290](#)
- [ADD USE FOR clause](#)
 - [ALTER TRUSTED CONTEXT statement 1374](#)
- [ADD VERSION clause](#)
 - [ALTER PROCEDURE \(SQL - native\) statement 1200](#)
- [ADD VOLUMES clause of ALTER STOGROUP statement 1229](#)
- [ADD_DAYS scalar function 383](#)
- [ADD_MONTHS function 384](#)
- [ADDRESS clause](#)
 - [ALTER TRUSTED CONTEXT statement 1372](#)
 - [CREATE TRUSTED CONTEXT statement 1790](#)
- [ADMIN_COMMAND_Db2 stored procedure 699](#)
- [ADMIN_COMMAND_DSN stored procedure 712](#)
- [ADMIN_COMMAND_MVS stored procedure 714](#)
- [ADMIN_COMMAND_UNIX stored procedure 725](#)
- [ADMIN_DB_BROWSE stored procedure 729](#)
- [ADMIN_DB_DELETE stored procedure 732](#)
- [ADMIN_DS_LIST stored procedure 735](#)
- [ADMIN_DS_RENAME stored procedure 741](#)
- [ADMIN_DS_SEARCH stored procedure 744](#)
- [ADMIN_DS_WRITE stored procedure 747](#)
- [ADMIN_EXPLAIN_MAINT 751](#)
- [ADMIN_INFO_HOST stored procedure 760](#)
- [ADMIN_INFO_SMS stored procedure 766](#)
- [ADMIN_INFO_SQL stored procedure 771](#)
- [ADMIN_INFO_SSID stored procedure 770](#)
- [ADMIN_INFO_SYSLOG stored procedure 781](#)
- [ADMIN_INFO_SYSPARM stored procedure 784](#)
- [ADMIN_JOB_CANCEL stored procedure 788](#)
- [ADMIN_JOB_FETCH stored procedure 791](#)
- [ADMIN_JOB_QUERY stored procedure 794](#)
- [ADMIN_JOB_SUBMIT stored procedure 798](#)
- [ADMIN_TASK_ADD stored procedure 802](#)
- [ADMIN_TASK_CANCEL stored procedure 808](#)
- [ADMIN_TASK_LIST function 669](#)
- [ADMIN_TASK_OUTPUT function 673](#)
- [ADMIN_TASK_REMOVE stored procedure 809](#)
- [ADMIN_TASK_STATUS function 675](#)
- [ADMIN_TASK_UPDATE stored procedure 811](#)
- [ADMIN_UPDATE_SYSPARM stored procedure 814](#)
- [ADMIN_UTL_EXECUTE](#)
 - [stored procedure 822](#)

- ADMIN_UTL_MODIFY
 - stored procedure [830](#)
- ADMIN_UTL_MONITOR
 - stored procedure [824](#)
- ADMIN_UTL_SCHEDULE stored procedure [832](#)
- ADMIN_UTL_SORT stored procedure [841](#)
- administrative task schedulers
 - ADMIN_TASK_CANCEL stored procedure [808](#)
 - ADMIN_TASK_UPDATE stored procedure [811](#)
- tasks
 - adding [802](#)
 - removing [809](#)
- AFTER clause
 - FETCH statement [1928](#)
- AFTER clause of CREATE TRIGGER statement [1348](#), [1746](#), [1773](#)
- aggregate function
 - COVAR_SAMP [361](#)
 - COVARIANCE_SAMP [361](#)
- alias
 - creating [1415](#)
 - description [88](#)
 - dropping [1891](#)
 - naming convention [79](#)
 - qualifying a column name [220](#)
 - unqualified name [86](#)
- ALIAS clause
 - COMMENT statement [1401](#)
 - CREATE ALIAS statement [1415](#)
 - DROP statement [1891](#)
 - LABEL statement [2016](#)
- aliases [32](#)
- ALL
 - clause of RELEASE statement [2064](#)
 - clause of subselect [1010](#)
 - keyword
 - aggregate functions [353](#)
 - AVG function [357](#)
 - COUNT function [358](#)
 - COUNT_BIG function [359](#)
 - MAX function [367](#)
 - MIN function [369](#)
 - STDDEV_POP function [376](#)
 - STDDEV_SAMP function [377](#)
 - SUM function [378](#)
 - VAR_POP function [379](#)
 - VARIANCE_SAMP function [380](#)
 - quantified predicate [300](#)
- ALL PRIVILEGES clause
 - GRANT statement [1988](#)
 - REVOKE statement [2101](#)
- ALL SQL clause of RELEASE statement [2064](#)
- ALLOBJAUTH
 - column of SYSDBNQRYPDEP catalog table [2446](#)
- ALLOCATE CURSOR statement
 - description [1093](#)
 - example [1093](#)
- ALLOW DEBUG MODE clause
 - ALTER PROCEDURE (external) statement [1188](#)
 - ALTER PROCEDURE (SQL - native) statement [1203](#)
 - CREATE PROCEDURE (external) statement [1588](#)
 - CREATE PROCEDURE (SQL - native) statement [1124](#), [1438](#), [1618](#)
- ALLOW PARALLEL clause
 - ALLOW PARALLEL clause (*continued*)
 - ALTER FUNCTION statement [1108](#)
 - CREATE FUNCTION statement [1437](#), [1467](#)
- ALLOWPUBLIC column
 - SYSCONTEXT catalog table [2401](#)
- alphabetic extender [75](#)
- ALTDAT function [2941](#)
- ALTDAT user-defined function
 - sample [20](#)
- ALTER ATTRIBUTES clause
 - ALTER TRUSTED CONTEXT statement [1372](#)
- ALTER clause
 - ALTER TRUSTED CONTEXT statement [1370](#)
- ALTER COLUMN clause
 - ALTER TABLE statement [1259](#)
- ALTER DATABASE statement
 - description [1095](#)
 - example [1095](#)
- ALTER FUNCTION (compiled SQL scalar) statement
 - description [1113](#)
 - examples [1141](#)
- ALTER FUNCTION (external scalar) statement
 - example [1112](#)
- ALTER FUNCTION (external) statement
 - description [1097](#)
- ALTER FUNCTION (inlined SQL scalar) statement
 - description [1142](#)
- ALTER FUNCTION (SQL scalar) statement
 - examples [1150](#)
- ALTER FUNCTION (SQL table) statement
 - description [1150](#)
 - examples [1157](#)
- ALTER INDEX statement
 - description [1157](#)
 - example [1173](#)
- ALTER MASK statement
 - description [1174](#)
 - examples [1177](#)
- ALTER MATERIALIZED QUERY clause
 - ALTER TABLE statement [1287](#)
- ALTER PARTITION
 - clause of ALTER INDEX statement [1170](#)
 - clause of CREATE TABLESPACE statement [1726](#)
- ALTER PARTITION clause
 - ALTER TABLE statement [1279](#)
 - ALTER TABLESPACE statement [1335](#)
- ALTER PERMISSION statement
 - description [1177](#)
 - examples [1179](#)
- ALTER privilege
 - GRANT statement [1979](#), [1988](#)
 - REVOKE statement [2093](#), [2101](#)
- ALTER PROCEDURE (external) statement
 - description [1180](#)
 - example [1189](#)
- ALTER PROCEDURE (SQL - external) statement
 - description [1189](#)
 - example [1194](#)
- ALTER PROCEDURE (SQL - native) statement
 - description [1194](#)
 - examples [1222](#)
- ALTER SEQUENCE statement
 - description [1224](#)
 - example [1228](#)

- ALTER STOGROUP statement
 - description [1228](#)
 - example [1231](#)
- ALTER TABLE statement
 - alternative syntax [1316](#)
 - check constraints
 - defining [27](#)
 - DEFAULT clause [25](#)
 - description [1232](#)
 - examples [1316](#)
- ALTER TABLESPACE statement
 - description [1321](#)
 - example [1342](#)
- ALTER TRIGGER statement
 - description [1342](#), [1365](#)
 - examples [1365](#), [1367](#)
- ALTER TRUSTED CONTEXT statement
 - description [1368](#)
 - examples [1378](#)
 - usage notes [1376](#)
- ALTER VERSION clause
 - ALTER PROCEDURE (SQL - native) statement [1200](#)
- ALTER VIEW statement
 - description [1378](#)
- ALTERAUTH
 - column of SYSSEQUENCEAUTH catalog table [2640](#)
- ALTERAUTH column of SYSTABAUTH catalog table [2659](#)
- ALTEREDTS
 - SYSSTOGROUP catalog table [2655](#)
- ALTEREDTS column
 - SYSCOLUMNS catalog table [2381](#)
 - SYSCONTEXT catalog table [2401](#)
 - SYSDATABASE catalog table [2427](#)
 - SYSINDEXES catalog table [2461](#)
 - SYSINDEXPART catalog table [2474](#)
 - SYSJAROBJECTS catalog table [2495](#)
 - SYSROUTINES catalog table [2621](#)
 - SYSSEQUENCES catalog table [2643](#)
 - SYSTABLEPART catalog table [2665](#)
 - SYSTABLES catalog table [2678](#)
 - SYSTABLESPACE catalog table [2688](#)
- ALTERIN privilege
 - GRANT statement [1978](#)
 - REVOKE statement [2091](#)
- ALTERINAUTH column of SYSSCHEMAAUTH catalog table [2638](#)
- alternative syntax
 - GRANT (type or JAR file privileges) statement [1991](#)
 - REVOKE (type or JAR file privileges) statement [2105](#)
 - SET PATH statement [2165](#)
- ALTTIME function [2943](#)
- ALTTIME user-defined function
 - sample [20](#)
- AND
 - truth table [319](#)
- ANY
 - quantified predicate [300](#)
 - USING clause of DESCRIBE statement [1874](#), [1882](#), [2044](#)
- APOST option
 - precompiler [324](#)
- apostrophe
 - string delimiter precompiler option [324](#)
- APOSTSQL option
 - precompiler [324](#)
- APP_ENCODING_CCSID column
 - SYSVIEWS catalog table [2730](#)
- APPEND
 - clause of CREATE TABLE statement [1700](#)
- APPEND clause
 - ALTER TABLE statement [1291](#)
- APPEND column
 - SYSTABLES catalog table [2678](#)
- APPLICATION ENCODING SCHEME clause
 - ALTER PROCEDURE (SQL - native) statement [1207](#)
 - CREATE PROCEDURE (SQL - native) statement [1126](#), [1441](#), [1622](#)
 - CREATE TRIGGER statement [1353](#), [1751](#)
- application plan
 - privileges
 - GRANT statement [1977](#)
 - REVOKE statement [2089](#)
- application plans [45](#), [57](#)
- application process
 - initial state in distributed unit of work [69](#)
 - initial state in remote unit of work [72](#)
 - state transitions [69](#)
- application processes [42](#), [43](#), [55](#)
- application program
 - SQLCA [2303](#)
 - SQLDA [2313](#)
- application programming
 - performance
 - for application programmers [2777](#)
 - recommendations [2777](#)
 - performance recommendations [2777](#)
- application programs
 - recovery [43](#), [55](#)
- application requester
 - definition of [68](#)
- application server
 - definition of [68](#)
- APPLICATION_ENCODING_CCSID column
 - SYSENVIRONMENT catalog table [2452](#)
- APPLICATION_ENCODING_SCHEME session variable [336](#)
- APREUSE_NO_FL column
 - SYSPACKAGE catalog table [2519](#)
- APREUSE_NO_TS column
 - SYSPACKAGE catalog table [2519](#)
- archive logs [40](#)
- ARCHIVE privilege
 - GRANT statement [1983](#)
 - REVOKE statement [2097](#)
- archive-enabled table
 - creating [1293](#)
- ARCHIVEAUTH column of SYSUSERAUTH catalog table [2715](#)
- arguments
 - passing to stored procedure [1387](#)
- arithmetic
 - regression functions [374](#)
- arithmetic operators [250](#)
- array
 - variable [234](#)
- array constructor
 - definition [279](#)
- array element specification
 - definition [278](#)

- array type
 - comparison of values [166](#)
 - creating [1795](#)
 - description [127](#)
 - naming convention [80](#)
- array variable
 - FETCH statement [1936](#)
- ARRAY_AGG function [354](#)
- ARRAY_DELETE function [386](#)
- ARRAY_EXISTS predicate [302](#)
- ARRAY_FIRST function [387](#)
- ARRAY_LAST function [388](#)
- ARRAY_NEXT function [389](#)
- ARRAY_PRIOR function [391](#)
- ARRAY_TRIM function [392](#)
- array-variable
 - SELECT INTO statement [2119](#)
- ARRAYINDEXSUBTYPE column
 - SYSDATATYPES catalog table [2429](#)
- ARRAYINDEXTYPEID column
 - SYSDATATYPES catalog table [2429](#)
- ARRAYINDEXTYPELEN column
 - SYSDATATYPES catalog table [2429](#)
- ARRAYLENGTH column
 - SYSDATATYPES catalog table [2429](#)
- AS (fullselect) WITH NO DATA clause
 - DECLARE GLOBAL TEMPORARY TABLE statement [1837](#)
- AS clause
 - CREATE VIEW statement [1815](#)
 - naming result columns [1011](#)
 - use in subselect [1011](#)
- AS IDENTITY clause
 - ALTER TABLE statement [1251](#)
 - CREATE TABLE statement [1676](#)
 - DECLARE GLOBAL TEMPORARY TABLE statement [1836](#)
- AS LOCATOR clause
 - CREATE FUNCTION statement [1458](#), [1477](#), [1503](#)
 - CREATE PROCEDURE (external) statement [1587](#)
 - CREATE PROCEDURE (SQL - native) statement [1617](#)
- AS SECURITY LABEL clause
 - ALTER TABLE statement [1257](#)
 - CREATE TABLE statement [1679](#)
- AS WORKFILE clause of CREATE DATABASE statement [1422](#)
- ASC clause
 - ALTER TABLE statement [1275](#)
 - CREATE INDEX statement [1532](#)
 - CREATE TABLE statement [1695](#)
 - select-statement [1045](#)
- ASCII
 - definition [59](#)
 - effect on MBCS and DBCS characters [104](#)
 - encoding schemes [17](#)
- ASCII function [393](#)
- ASCII_CHR function [393](#)
- ASCII_STR function [394](#)
- ASCIIISTR function [394](#)
- ASENSITIVE clause
 - DECLARE CURSOR statement [1821](#)
- ASIN function [395](#)
- assembler application program
 - host variable
 - EXECUTE IMMEDIATE statement [1915](#)
 - referencing [227](#)
 - INCLUDE SQLCA [2308](#)
- assembler application program (*continued*)
 - INCLUDE SQLDA [2326](#)
 - varying-length string variables [104](#)
- assignment
 - compatibility rules [143](#)
 - datetime values [151](#)
 - numbers [145](#)
 - row ID values [153](#)
 - statement
 - example [2217](#), [2281](#)
 - SQL procedure [2217](#), [2281](#)
 - strings, basic rules for [149](#)
 - user-defined type values [153](#)
 - XML values [153](#)
- ASSOCIATE LOCATORS statement
 - description [1380](#)
 - example [1382](#)
- asterisk (*)
 - COUNT function [358](#)
 - COUNT_BIG function [359](#)
 - multiply sign [250](#)
 - use in subselect [1011](#)
- ASUTIME clause
 - ALTER FUNCTION statement [1109](#)
 - ALTER PROCEDURE (external) statement [1186](#)
 - ALTER PROCEDURE (SQL - external) statement [1192](#)
 - ALTER PROCEDURE (SQL - native) statement [1204](#)
 - CREATE FUNCTION statement [1468](#), [1486](#)
 - CREATE PROCEDURE (external) statement [1593](#)
 - CREATE PROCEDURE (SQL - external) statement [1604](#)
 - CREATE PROCEDURE (SQL - native) statement [1124](#), [1438](#), [1619](#)
 - CREATE TRIGGER statement [1351](#), [1749](#)
- ASUTIME column
 - SYSROUTINES catalog table [2621](#)
 - SYSTRIGGERS catalog table [2712](#)
- ATAN function [395](#)
- ATAN2 function [396](#)
- ATANH function [395](#)
- ATOMIC clause
 - INSERT statement [2005](#)
 - PREPARE statement [2049](#)
- ATTRIBUTES clause
 - CREATE TRUSTED CONTEXT statement [1790](#)
 - PREPARE statement [2045](#)
- AUDIT
 - clause of CREATE TABLE statement [1697](#)
- AUDIT clause
 - ALTER TABLE statement [1292](#)
- auditing
 - ALTER TABLE statement [1292](#)
 - CREATE TABLE statement [1697](#)
- AUDITING column of SYSTABLES catalog table [2678](#)
- AUTHENTICATE column
 - SYSCONTEXTAUTHIDS catalog table [2404](#)
- AUTHENTICATEPUBLIC column
 - SYSCONTEXT catalog table [2401](#)
- AUTHHOWGOT
 - column of SYSSEQUENCEAUTH catalog table [2640](#)
- AUTHHOWGOT column
 - SYSDBAUTH catalog table [2432](#)
 - SYSPACKAUTH catalog table [2536](#)
 - SYSPLANAUTH catalog table [2582](#)
 - SYSRESAUTH catalog table [2615](#)

AUTHHOWGOT column (*continued*)
 SYSROUTINEAUTH catalog table [2619](#)
 SYSCHEMAAUTH catalog table [2638](#)
 SYSUSERAUTH catalog table [2715](#)
 SYSVARIABLEAUTH catalog table [2722](#)
 AUTHHOWGOT column of SYSTABAUTH catalog table [2659](#)
 AUTHID
 column of MODESELECT catalog table [2358](#)
 column of SYSCOPY catalog table [2408](#)
 column of SYSDYNQRYDEP catalog table [2446](#)
 column of USERNAMES catalog table [2737](#)
 AUTHID column
 SYSCONTEXTAUTHIDS catalog table [2404](#)
 AUTHID_TYPE
 column of SYSDYNQRYDEP catalog table [2446](#)
 authorization
 clause of CONNECT statement [1410](#)
 naming convention [80](#)
 authorization ID
 primary [92](#)
 privileges [90](#)
 secondary [92](#)
 translating
 concepts [98](#)
 autonomic statistics
 stored procedures
 ADMIN_UTL_EXECUTE [822](#)
 ADMIN_UTL_MODIFY [830](#)
 ADMIN_UTL_MONITOR [824](#)
 AUX clause of CREATE AUXILIARY TABLE statement [1419](#)
 aux-table
 naming convention [80](#)
 AUXILIARY clause of CREATE AUXILIARY TABLE statement [1419](#)
 auxiliary table
 CREATE AUXILIARY TABLE statement [1418](#)
 AUXRELOBID column
 SYSAXRELS catalog table [2368](#)
 AXTBNAME column of SYSAXRELS catalog table [2368](#)
 AXTBOWNER column of SYSAXRELS catalog table [2368](#)
 AVG function [357](#)
 AVGKEYLEN column
 SYSINDEXES catalog table [2461](#)
 SYSINDEXES_HIST catalog table [2472](#)
 SYSINDEXPART catalog table [2474](#)
 SYSINDEXPART_HIST catalog table [2480](#)
 AVGROWLEN column
 SYSTABLEPART catalog table [2665](#)
 SYSTABLEPART_HIST catalog table [2675](#)
 SYSTABLES catalog table [2678](#)
 SYSTABLES_HIST catalog table [2707](#)
 SYSTABLESPACE catalog table [2688](#)
 AVGSIZE column
 SYSLOBSTATS catalog table [2516](#)
 SYSPACKAGE catalog table [2519](#)
 SYSPLAN catalog table [2575](#)

B

BASE64DECODE function [2945](#)
 BASE64ENCODE function [2945](#)
 BASED UPON CONNECTION clause
 CREATE TRUSTED CONTEXT statement [1789](#)
 basic operations in SQL [143](#)
 basic predicate [297](#)
 BAUTH
 column of SYSDYNQRYDEP catalog table [2446](#)
 BAUTH column
 SYSDEPENDENCIES catalog table [2439](#)
 BCOLNAME column
 SYSDEPENDENCIES catalog table [2439](#)
 BCOLNO column
 SYSDEPENDENCIES catalog table [2439](#)
 BCREATOR column
 SYSPLANDEP catalog table [2584](#)
 SYSVIEWDEP catalog table [2729](#)
 BEFORE clause of CREATE TRIGGER statement [1348](#), [1746](#), [1772](#)
 BEGIN DECLARE SECTION statement
 description [1383](#)
 example [1384](#)
 BETWEEN predicate [303](#)
 BIGINT
 data type
 CREATE TABLE statement [1663](#)
 BIGINT (binary large integer) function [396](#)
 BINARY
 data type [1663](#)
 BINARY function [397](#)
 binary large object (BLOB) [116](#)
 BINARY LARGE OBJECT data type [116](#)
 binary string
 constants [172](#)
 description [116](#)
 operands [168](#)
 binary strings
 varying-length
 description [116](#)
 bind behavior for dynamic SQL statements [94](#)
 BIND PACKAGE subcommand of DSN
 options
 QUALIFIER [86](#)
 BIND PLAN subcommand of DSN
 options
 QUALIFIER [86](#)
 BIND privilege
 GRANT statement [1975](#), [1977](#)
 REVOKE statement [2087](#), [2089](#)
 bind process [93](#)
 BIND_OPTS column
 SYSJAVA_OPTS catalog table [2496](#)
 SYSROUTINES_OPTS catalog table [2635](#)
 BINDADD privilege
 binding a package [96](#)
 GRANT statement [1983](#)
 REVOKE statement [2097](#)
 BINDADDAUTH column of SYSUSERAUTH catalog table [2715](#)
 BINDAGENT privilege
 GRANT statement [1983](#)
 REVOKE statement [2097](#)
 BINDAGENTAUTH column of SYSUSERAUTH catalog table [2715](#)
 BINDAUTH column
 SYSPACKAUTH catalog table [2536](#)
 SYSPLANAUTH catalog table [2582](#)
 BINDERROR column of SYSPACKSTMT catalog table [2558](#)
 binding

binding (*continued*)
 process [93](#)

BINDTIME column
 SYSPACKAGE catalog table [2519](#)

BIT data
 description [104](#)

BIT string subtype [17](#)

BITAND function [398](#)

BITANDNOT function [398](#)

BITNOT function [398](#)

BITOR function [398](#)

BITXOR function [398](#)

BLOB
 length [17](#)
 LOB data type [22](#)

BLOB (binary large object)
 data type
 description [116](#)
 description [116](#)
 file reference [232](#)
 locator [230](#)
 variable [230](#)

BLOB (binary large object) function [400](#)

BLOB LARGE OBJECT data type [1663](#)

BLOCKING_THREADS function [678](#)

BNAME
 column of SYSDYNQRYDEP catalog table [2446](#)

BNAME column
 SYSCONSTDEP catalog table [2400](#)
 SYSDEPENDENCIES catalog table [2439](#)
 SYSPACKDEP catalog table [2554](#)
 SYSPLANDEP catalog table [2584](#)
 SYSVIEWDEP catalog table [2729](#)

BNAME column of SYSSEQUENCEDEP catalog table [2646](#)

bootstrap data set (BSDS)
 overview [40](#)

BOTH
 USING clause of DESCRIBE statement [1874](#), [1882](#)

BOUNDBY column of SYSPLAN catalog table [2575](#)

BOUNDTS column
 SYSPLAN catalog table [2575](#)

BOWNER column
 SYSDEPENDENCIES catalog table [2439](#)

BOWNERTYPE column
 SYSDEPENDENCIES catalog table [2439](#)

BPOOL column
 SYSDATABASE catalog table [2427](#)
 SYSINDEXES catalog table [2461](#)
 SYSTABLESPACE catalog table [2688](#)

BQUALIFIER
 column of SYSDYNQRYDEP catalog table [2446](#)

BQUALIFIER column of SYSPACKDEP catalog table [2554](#)

BSHEMA column
 SYSCONSTDEP catalog table [2400](#)
 SYSDEPENDENCIES catalog table [2439](#)
 SYSVIEWDEP catalog table [2729](#)

BSHEMA column of SYSSEQUENCEDEP catalog table [2646](#)

BSDS (bootstrap data set)
 privilege
 granting [1983](#)
 revoking [2097](#)

BSDSAUTH column of SYSUSERAUTH catalog table [2715](#)

BSEQUENCEID column of SYSSEQUENCEDEP catalog table [2646](#)

BTRIM function [401](#)

BTYPE
 column of SYSDYNQRYDEP catalog table [2446](#)

BTYPE column
 SYSCONSTDEP catalog table [2400](#)
 SYSDEPENDENCIES catalog table [2439](#)
 SYSPACKDEP catalog table [2554](#)
 SYSPLANDEP catalog table [2584](#)
 SYSVIEWDEP catalog table [2729](#)

buffer pool
 naming convention [80](#)

buffer pools
 described [41](#)

BUFFERPOOL
 clause of CREATE TABLE statement [1701](#)

BUFFERPOOL clause
 ALTER DATABASE statement [1095](#)
 ALTER INDEX statement [1161](#)
 ALTER TABLESPACE statement [1324](#)
 CREATE DATABASE statement [1422](#)
 CREATE INDEX statement [1544](#)
 CREATE LOB TABLESPACE statement [1556](#)
 CREATE TABLESPACE statement [1724](#)

BUFFERPOOL privilege
 GRANT statement [1993](#)
 REVOKE statement [2108](#)

BUILDDATE column
 SYSROUTINES_OPTS catalog table [2635](#)
 SYSROUTINES_SRC catalog table [2637](#)

BUILDNAME column
 SYSJAVA_OPTS catalog table [2496](#)
 SYSROUTINES_OPTS catalog table [2635](#)

BUILDOWNER column
 SYSJAVA_OPTS catalog table [2496](#)
 SYSROUTINES_OPTS catalog table [2635](#)

BUILDSHEMA column
 SYSJAVA_OPTS catalog table [2496](#)
 SYSROUTINES_OPTS catalog table [2635](#)

BUILDSTATUS column
 SYSROUTINES_OPTS catalog table [2635](#)
 SYSROUTINES_SRC catalog table [2637](#)

BUILDTIME column
 SYSROUTINES_OPTS catalog table [2635](#)
 SYSROUTINES_SRC catalog table [2637](#)

built-in data type [98](#)

built-in function
 description [237](#)
 invocation [242](#)
 resolution [239](#), [243](#)
 string units [106](#)

built-in functions
 list [341](#)

built-in global variable
 CATALOG_LEVEL [329](#)
 CLIENT_IPADDR [330](#)
 DEFAULT_SQLLEVEL [330](#)
 GET_ARCHIVE [330](#)
 MAX_LOCKS_PER_TABLESPACE [331](#)
 MAX_LOCKS_PER_USER [331](#)
 MOVE_TO_ARCHIVE [332](#)
 PRODUCTID_EXT [332](#)
 REPLICATION_OVERRIDE [333](#)
 TEMPORAL_LOGICAL_TRANSACTION_TIME [334](#)
 TEMPORAL_LOGICAL_TRANSACTIONS [334](#)

built-in session variables [227](#)
business rules
 enforcing [15](#), [32](#)
 triggers [32](#)
BUSINESS_TIME SENSITIVE clause
 CREATE TRIGGER statement [1357](#), [1755](#)
BY clause of REVOKE statement [2071](#)

C

C application program
 host variable
 EXECUTE IMMEDIATE statement [1915](#)
 referencing [227](#)
 INCLUDE SQLCA [2308](#)
 INCLUDE SQLDA [2326](#)
 varying-length string [104](#)
CACHE
 clause of ALTER SEQUENCE statement [1226](#)
CACHE clause
 ALTER TABLE statement [1253](#)
 CREATE SEQUENCE statement [1642](#)
CACHE column of SYSSEQUENCES catalog table [2643](#)
CACHESIZE
 column of SYSPLAN catalog table [2575](#)
Call Level Interface (CLI) [3](#)
CALL statement
 description [1384](#)
 example [1394](#), [2218](#), [2282](#)
 SQL procedure [2218](#), [2282](#)
CALLED ON NULL INPUT clause
 ALTER FUNCTION statement [1105](#), [1148](#)
 CREATE FUNCTION (inlined SQL scalar) statement [1496](#)
 CREATE FUNCTION statement [1437](#), [1463](#), [1482](#)
 CREATE PROCEDURE (external) statement [1595](#)
 CREATE PROCEDURE (SQL - external) statement [1603](#)
capturing changed data
 ALTER TABLE statement [1288](#)
 CREATE TABLE statement [1698](#)
CARD column
 SYSTABLEPART catalog table
 description [2665](#)
 SYSTABSTATS catalog table
 description [2710](#)
CARDF column
 SYSCOLDIST catalog table [2373](#)
 SYSCOLDIST_HIST catalog table [2377](#)
 SYSCOLDISTSTATS catalog table [2375](#)
 SYSINDEXPART catalog table [2474](#)
 SYSINDEXPART_HIST catalog table [2480](#)
 SYSKEYTARGETS catalog table [2500](#)
 SYSKEYTARGETS_HIST catalog table [2505](#)
 SYSKEYTARGETSTATS catalog table [2503](#)
 SYSKEYTGTDIST catalog table [2509](#)
 SYSKEYTGTDIST_HIST catalog table [2513](#)
 SYSKEYTGTDISTSTATS catalog table [2511](#)
 SYSTABLEPART catalog table [2665](#)
 SYSTABLEPART_HIST catalog table [2675](#)
 SYSTABLES catalog table [2678](#)
 SYSTABLES_HIST catalog table [2707](#)
 SYSTABSTATS catalog table [2710](#)
 SYSTABSTATS_HIST catalog table [2711](#)
CARDINALITY clause [1021](#)
CARDINALITY column

CARDINALITY column (*continued*)
 SYSROUTINES catalog table [2621](#)
CARDINALITY function [402](#)
CARDINALITY MULTIPLIER clause [1021](#)
CASCADE delete rule
 ALTER TABLE statement [1271](#)
 CREATE TABLE statement [1684](#)
cascade revoke [2072](#)
CASE expression
 description [264](#)
CASE statement
 example [2219](#), [2284](#)
 SQL procedure [2219](#), [2284](#)
cast function [238](#)
CAST specification
 definition [267](#)
 NULL [267](#)
 parameter marker [267](#)
 string units [106](#)
CAST_FUNCTION column
 SYSPARMS catalog table [2565](#)
 SYSROUTINES catalog table [2621](#)
CAST_FUNCTION_ID column of SYSPARMS catalog table [2565](#)
casting
 XML values [277](#)
casts
 data types [130](#)
catalog
 naming convention [80](#)
catalog indexes [2744](#)
catalog name
 VCAT clause
 ALTER INDEX statement [1163](#)
 CREATE INDEX statement [1538](#)
 CREATE LOB TABLESPACE statement [1559](#)
 CREATE TABLESPACE statement [1732](#)
catalog tables
 description [2333](#)
 history tables [2742](#)
 IPLIST [2348](#)
 IPNAMES [2349](#)
 LOCATIONS [2351](#)
 LULIST [2353](#)
 LUMODES [2353](#)
 LUNAMES [2354](#)
 MODESELECT [2358](#)
 release dependency indicators [2333](#)
 SQL statements allowed [2739](#)
 SYSAUDITPOLICIES
 contents [2358](#)
 SYSAUTOALERTS [2364](#)
 SYSAUTOALERTS_OUT [2365](#)
 SYSAUTORUNS_HIST [2366](#)
 SYSAUTORUNS_HISTOU [2366](#)
 SYSAUTOTIMEWINDOWS [2367](#)
 SYSAUXRELS [2368](#)
 SYSCHECKDEP [2369](#)
 SYSCHECKS [2369](#)
 SYSCHECKS2 [2370](#)
 SYSCOLAUTH [2371](#)
 SYSCOLDIST
 contents [2373](#)
 SYSCOLDISTSTATS

catalog tables (continued)

[SYSCOLDISTSTATS \(continued\)](#)
[contents 2375](#)
[SYSCOLSTATS](#)
[contents 2379](#)
[SYSCOLUMNS](#)
[contents 2381](#)
[SYSCOLUMNS_HIST](#)
[contents 2395](#)
[SYSCONSTDEP 2400](#)
[SYSCONTEXT](#)
[contents 2401](#)
[SYSCONTEXTAUTHIDS](#)
[contents 2404](#)
[SYSCONTROLS](#)
[contents 2405](#)
[SYSCOPY](#)
[contents 2408](#)
[SYSCTXTTRUSTATTRS](#)
[contents 2426](#)
[SYSDATABASE](#)
[contents 2427](#)
[SYSDATATYPES 2429](#)
[SYSDBAUTH 2432](#)
[SYSDBRM 2437](#)
[SYSDEPENDENCIES 2439](#)
[SYSDUMMY1 2443](#)
[SYSDUMMYA 2443](#)
[SYSDUMMYE 2444](#)
[SYSDUMMYU 2444](#)
[SYSDYNQRY](#)
[contents 2444](#)
[SYSDYNQRYDEP](#)
[contents 2446](#)
[SYSENVIRONMENT 2452](#)
[SYSFIELDS 2456](#)
[SYSFORIGNKEYS 2458](#)
[SYSIBM.SYSINDEXCLEANUP 2458](#)
[SYSIBM.SYSQUERYSEL 2611](#)
[SYSIBM.SYSSTATFEEDBACK 2649](#)
[SYSIBMS.SYSQUERYPREDICATE 2606](#)
[SYSINDEXCONTROL](#)
[contents 2460](#)
[SYSINDEXES](#)
[contents 2461](#)
[SYSINDEXES_HIST](#)
[contents 2472](#)
[SYSINDEXES_RTSECT 2474](#)
[SYSINDEXES_TREE 2474](#)
[SYSINDEXPART](#)
[contents 2474](#)
[SYSINDEXPART_HIST 2480](#)
[SYSINDEXSPACESTATS](#)
[contents 2482](#)
[SYSINDEXSTATS](#)
[contents 2490](#)
[SYSINDEXSTATS_HIST 2492](#)
[SYSJARCLASS_SOURCE 2494](#)
[SYSJARCONTENTS 2494](#)
[SYSJARDATA 2495](#)
[SYSJAROBJECTS 2495](#)
[SYSJAVAOPTS 2496](#)
[SYSJAVAPATHS 2497](#)
[SYSKEYCOLUSE 2497](#)

catalog tables (continued)

[SYSKEYS 2498](#)
[SYSKEYTARGETS](#)
[contents 2500](#)
[SYSKEYTARGETS_HIST](#)
[contents 2505](#)
[SYSKEYTARGETSTATS](#)
[contents 2503](#)
[SYSKEYTGTDIST](#)
[contents 2509](#)
[SYSKEYTGTDIST_HIST](#)
[contents 2513](#)
[SYSKEYTGTDISTSTATS](#)
[contents 2511](#)
[SYSLEVELUPDATES 2515](#)
[SYSLOBSTATS 2516](#)
[SYSLOBSTATS_HIST 2516](#)
[SYSOBJROLEDEP](#)
[contents 2517](#)
[SYSPACKAGE 2519](#)
[SYSPACKAUTH 2536](#)
[SYSPACKCOPY 2538](#)
[SYSPACKDEP 2554](#)
[SYSPACKLIST 2558](#)
[SYSPACKSTMT 2558](#)
[SYSPACKSTMT_STMB 2565](#)
[SYSPACKSTMT_STMT 2565](#)
[SYSPARMS 2565](#)
[SYSPENDINGDDL](#)
[contents 2570](#)
[SYSPENDINGOBJECTS](#)
[contents 2572](#)
[SYSPKSYSTEM 2574](#)
[SYSPLAN 2575](#)
[SYSPLANAUTH](#)
[contents 2582](#)
[SYSPLANDEP](#)
[contents 2584](#)
[SYSPLSYSTEM 2586](#)
[SYSQUERY 2587](#)
[SYSQUERY_AUX 2613](#)
[SYSQUERYOPTS 2590](#)
[SYSQUERYPLAN 2592](#)
[SYSRELS](#)
[contents 2613](#)
[SYSRESAUTH 2615](#)
[SYSROLES](#)
[contents 2618](#)
[SYSROUTINEAUTH 2619](#)
[SYSROUTINES](#)
[contents 2621](#)
[SYSROUTINES_OPTS 2635](#)
[SYSROUTINES_SRC 2637](#)
[SYSROUTINES_TREE 2637](#)
[SYSROUTINESTEXT](#)
[contents 2635](#)
[SYSSCHEMAAUTH 2638](#)
[SYSSEQUENCEAUTH 2640](#)
[SYSSEQUENCES 2643](#)
[SYSSEQUENCESDEP 2646](#)
[SYSSESESSION 2647](#)
[SYSSESESSION_EX 2648](#)
[SYSSESESSION_STATUS 2648](#)
[SYSSTMT 2651](#)

catalog tables (*continued*)

- SYSSTOGROUP
 - contents [2655](#)
- SYSSTRINGS
 - contents [2656](#)
- SYSSYNONYMS [2658](#)
- SYSTABAUTH
 - contents [2659](#)
- SYSTABCONST
 - contents [2664](#)
- SYSTABLEPART
 - contents [2665](#)
- SYSTABLEPART_HIST
 - contents [2675](#)
- SYSTABLES
 - contents [2678](#)
- SYSTABLES_HIST
 - contents [2707](#)
- SYSTABLES_PROFILE_TEXT [2710](#)
- SYSTABLES_PROFILES [2709](#)
- SYSTABLESPACE
 - contents [2688](#)
- SYSTABLESPACESTATS
 - contents [2699](#)
- SYSTABSTATS
 - contents [2710](#)
- SYSTABSTATS_HIST
 - contents [2711](#)
- SYSTRIGGERS [2712](#)
- SYSTRIGGERS_STMT [2715](#)
- SYSUSERAUTH [2715](#)
- SYSVARIABLEAUTH [2722](#)
- SYSVARIABLES [2724](#)
- SYSVARIABLES_DESC [2728](#)
- SYSVARIABLES_TEXT [2728](#)
- SYSVIEWDEP
 - contents [2729](#)
- SYSVIEWS [2730](#)
- SYSVIEWS_STMT [2733](#)
- SYSVIEWS_TREE [2733](#)
- SYSVOLUMES [2733](#)
- SYSXMLRELS [2734](#)
- SYSXMLSTRINGS [2735](#)
- SYSXMLTYPMOD [2735](#)
- SYSXMLTYPMSHEMA [2736](#)
- temporal data [2742](#)
- USERNAMES [2737](#)

CATALOG_LEVEL

- built-in global variable [329](#)

catalog, DB2

- tables [2333](#)

catalogs [38](#)

CCSID

- clause of CREATE DATABASE statement [1423](#)
- clause of CREATE FUNCTION (inlined SQL scalar) statement [1494](#)
- clause of CREATE FUNCTION statement [1434](#), [1458](#), [1477](#), [1502](#)
- clause of CREATE GLOBAL TEMPORARY TABLE statement [1521](#)
- clause of CREATE TABLE statement [1698](#)
- clause of CREATE TABLESPACE statement [1727](#)
- clause of CREATE TYPE (distinct) statement [1803](#)

CCSID (*continued*)

- clause of DECLARE GLOBAL TEMPORARY TABLE statement [1839](#)
- column of SYSPARMS catalog table [2565](#)

CCSID (coded character set identifier)

- definition [59](#)
- Definition [62](#)
- description [59](#)

CCSID (Coded Character Set Identifier)

- of strings [63](#)

CCSID clause

- ALTER DATABASE statement [1095](#)
- ALTER TABLESPACE statement [1324](#)
- CREATE PROCEDURE (external) statement [1586](#)
- CREATE PROCEDURE (SQL - external) statement [1601](#)

CCSID column

- SYSCOLUMNS catalog table [2381](#)
- SYSKEYTARGETS catalog table [2500](#)
- SYSVARIABLES catalog table [2724](#)

CCSID_ENCODING function [403](#)

CDB (communications database) [38](#)

CEIL function [404](#)

CEILING function [404](#)

CHAR

- data type [103](#)

CHAR function [405](#)

CHAR LARGE OBJECT data type [103](#), [1663](#)

CHAR VARYING data type [103](#), [1663](#)

CHAR_LENGTH function [413](#)

character [75](#)

character conversion

- ASCII [59](#)
- character set [59](#)
- code page [59](#)
- code point [59](#)
- coded character set [59](#)
- comparison rules [159](#)
- concatenation rules [1066](#)
- contracting conversion [68](#)
- description [59](#)
- EBCDIC [59](#)
- encoding scheme [59](#)
- expanding conversion [67](#)
- set operations rules [1066](#)
- substitution character [59](#)
- SYSIBM.SYSSTRINGS catalog table [2656](#)
- Unicode [59](#)
- UTF-16 [59](#)
- UTF-8 [59](#)

Character conversion

- Coded character sets and ccsids [62](#)

CHARACTER data type

- CREATE TABLE statement [1663](#)
- description [103](#)

character large object (CLOB) [116](#)

CHARACTER LARGE OBJECT data type [103](#), [1663](#)

character set [59](#)

character string

- comparison [157](#)
- description [102](#)
- empty [102](#)
- operands [168](#)

character strings

- BTRIM scalar function [401](#)

CHARACTER VARYING data type [103](#), [1663](#)
 CHARACTER_LENGTH function [413](#)
 CHARSET column
 SYSDBRM catalog table [2437](#)
 SYSENVIRONMENT catalog table [2452](#)
 SYSPACKAGE catalog table [2519](#)
 CHECK
 clause of CREATE TABLE statement [1685](#)
 column of SYSVIEWS catalog table [2730](#)
 CHECK clause
 ALTER TABLE statement [1273](#)
 check constraint
 defining
 ALTER TABLE statement [1273](#)
 SYSCHECKDEP catalog table [2369](#)
 check constraints
 column values
 enforcing validity [27](#)
 inserting rows into tables [27](#)
 updating tables [27](#)
 CHECKCONDITION column
 SYSCHECKS catalog table [2369](#)
 CHECKEXISTINGDATA column
 SYSRELS catalog table [2613](#)
 CHECKFLAG column
 SYSTABLEPART catalog table [2665](#)
 SYSTABLES catalog table [2678](#)
 CHECKNAME column
 SYSCHECKDEP catalog table [2369](#)
 SYSCHECKS catalog table [2369](#)
 SYSCHECKS2 catalog table [2370](#)
 CHECKRID5B column
 SYSTABLEPART catalog table [2665](#)
 SYSTABLES catalog table [2678](#)
 CHECKS column
 SYSTABLES catalog table [2678](#)
 CHILDREN column of SYSTABLES catalog table [2678](#)
 CHR function [415](#)
 CLASS
 column of SYSDYNQRYDEP catalog table [2446](#)
 CLASS column
 SYSJARCONTENTS catalog table [2494](#)
 SYSROUTINES catalog table [2621](#)
 CLASS_SOURCE column
 SYSJARCLASS_SOURCE catalog table [2494](#)
 SYSJARCONTENTS catalog table [2494](#)
 CLASS_SOURCE_ROWID column
 SYSJARCONTENTS catalog table [2494](#)
 CLI (Call Level Interface) [3](#)
 CLIENT_IPADDR
 built-in global variable [330](#)
 CLOB
 LOB data type [22](#)
 CLOB (character large object)
 description [103](#), [116](#), [1663](#)
 file reference [232](#)
 function [415](#)
 locator [230](#)
 variable [230](#)
 CLONE column
 SYSTABLESPACE catalog table [2688](#)
 clone table
 naming convention [80](#)
 CLOSE
 CLOSE (*continued*)
 clause of ALTER INDEX statement [1161](#)
 clause of CREATE INDEX statement
 description [1544](#)
 clause of CREATE TABLESPACE statement
 description [1556](#), [1728](#)
 statement
 description [1395](#)
 example [1396](#)
 CLOSE clause
 ALTER TABLESPACE statement [1325](#)
 closed state of cursor [2039](#)
 CLOSERULE column
 SYSINDEXES catalog table [2461](#)
 SYSTABLESPACE catalog table [2688](#)
 CLUSTER clause
 ALTER INDEX statement [1167](#)
 CREATE INDEX statement [1537](#)
 CLUSTERED column
 SYSINDEXES catalog table [2461](#)
 CLUSTERING column
 SYSINDEXES catalog table [2461](#)
 SYSINDEXES_HIST catalog table [2472](#)
 CLUSTERRATIO column
 SYSINDEXES catalog table [2461](#)
 SYSINDEXSTATS catalog table [2490](#)
 CLUSTERRATIOF column
 SYSINDEXES catalog table [2461](#)
 SYSINDEXES_HIST catalog table [2472](#)
 SYSINDEXSTATS catalog table [2490](#)
 SYSINDEXSTATS_HIST catalog table [2492](#)
 CLUSTERTYPE column of SYSTABLES catalog table [2678](#)
 CNAME column
 SYSPKSYSTEM catalog table [2574](#)
 SYSPLSYSTEM catalog table [2586](#)
 COALESCE function [166](#), [417](#), [479](#)
 COBOL application program
 host structure [235](#)
 host variable
 description [227](#)
 EXECUTE IMMEDIATE statement [1915](#)
 host-variable-arrays [236](#)
 INCLUDE SQLCA [2308](#)
 varying-length string [104](#)
 COBOL_STRING_DELIMITER session variable [336](#)
 code page [59](#)
 code point [59](#)
 coded character set [59](#)
 CODEUNITS16 [106](#)
 CODEUNITS32 [106](#)
 COLCARDATA column of SYSCOLSTATS catalog table [2379](#)
 COLCARDF column
 SYSCOLUMNS catalog table [2381](#)
 SYSCOLUMNS_HIST catalog table [2395](#)
 COLCOUNT column
 SYSINDEXES catalog table [2461](#)
 SYSRELS catalog table [2613](#)
 SYSTABCONST catalog table [2664](#)
 SYSTABLES catalog table [2678](#)
 SYSTABLES_HIST catalog table [2707](#)
 COLGROUPOCOLNO column
 SYSCOLDIST catalog table [2373](#)
 SYSCOLDIST_HIST catalog table [2377](#)
 SYSCOLDISTSTATS catalog table [2375](#)

- COLLATION_KEY function [418](#)
- collection-derived table
 - description [1031](#)
- collection-id
 - naming convention [80](#)
- collection, package
 - granting privileges [1967](#)
 - revoking privileges [2076](#)
 - SET CURRENT PACKAGESET statement [2146](#)
- COLLID
 - column of SYSSEQUENCEAUTH catalog table [2640](#)
- COLLID clause
 - ALTER FUNCTION statement [1109](#)
 - ALTER PROCEDURE (external) statement [1186](#)
 - ALTER PROCEDURE (SQL - external) statement [1191](#)
 - CREATE FUNCTION statement [1467](#), [1485](#)
 - CREATE PROCEDURE (external) statement [1593](#)
 - CREATE PROCEDURE (SQL - external) statement [1603](#)
- COLLID column
 - SYSCOLAUTH catalog table [2371](#)
 - SYSPACKAGE catalog table [2519](#)
 - SYSPACKAUTH catalog table [2536](#)
 - SYSPACKLIST catalog table [2558](#)
 - SYSPACKSTMT catalog table [2558](#)
 - SYSPKSYSTEM catalog table [2574](#)
 - SYSROUTINEAUTH catalog table [2619](#)
 - SYSROUTINES catalog table [2621](#)
 - SYSTABAUTH catalog table [2659](#)
 - SYSVARIABLEAUTH catalog table [2722](#)
- COLNAME column
 - SYSAUXRELS catalog table [2368](#)
 - SYSCHECKDEP catalog table [2369](#)
 - SYSFOREIGNKEYS catalog table [2458](#)
 - SYSKEYCOLUSE catalog table [2497](#)
 - SYSKEYS catalog table [2498](#)
 - SYSXMLRELS catalog table [2734](#)
- COLNAME column of SYSCOLAUTH catalog table [2371](#)
- COLNO column
 - SYSCOLUMNS_HIST catalog table [2395](#)
 - SYSFIELDS catalog table [2456](#)
 - SYSFOREIGNKEYS catalog table [2458](#)
 - SYSKEYCOLUSE catalog table [2497](#)
 - SYSKEYS catalog table [2498](#)
 - SYSKEYTARGETS catalog table [2500](#)
- COLNO column of SYSCOLUMNS catalog table [2381](#)
- colon
 - host variable in SQL [227](#)
- COLSEQ column
 - SYSFOREIGNKEYS catalog table [2458](#)
 - SYSKEYCOLUSE catalog table [2497](#)
 - SYSKEYS catalog table [2498](#)
- COLSTATUS column of SYSCOLUMNS catalog table [2381](#)
- COLTYPE column
 - SYSCOLUMNS_HIST catalog table [2395](#)
- COLTYPE column of SYSCOLUMNS catalog table [2381](#)
- column
 - derived
 - CREATE VIEW statement [1814](#)
 - DELETE statement [1861](#)
 - functions [341](#)
 - INSERT statement [2000](#)
 - string comparison [159](#)
 - UPDATE statement [2187](#)
 - name
 - column (*continued*)
 - name (*continued*)
 - ambiguous reference [221](#)
 - correlated reference [222](#)
 - in a result [1014](#)
 - undefined reference [221](#)
 - naming convention [80](#)

- COLUMN clause
- COMMENT statement [1401](#)
- LABEL statement [2016](#)
- column definitions
- components of
 - datetime data types [20](#)
 - ROWID data type [22](#)
 - string data types [17](#)
- distinct types [23](#)
- large object (LOB) data types [22](#)
- column mask
- altering [1174](#)
- column masks
- creating [1562](#)
- columns
- choosing a data type [16](#)
- values
 - enforcing validity [27](#)
- COLVALUE column
- SYSCOLDIST catalog table [2373](#)
- SYSCOLDIST_HIST catalog table [2377](#)
- SYSCOLDISTSTATS catalog table
 - description [2375](#)
- COMMA
- column of SYSDBRM catalog table [2437](#)
- column of SYSPACKAGE catalog table [2519](#)
- option of precompiler [323](#)
- comment
- adding [1396](#)
- replacing [1396](#)
- SQL [75](#)
- COMMENT ON statement
- column name qualification [220](#)
- COMMENT statement
- description [1396](#)
- example [1405](#)
- comments
- SQL statements [1092](#)
- COMMIT ON RETURN clause
- ALTER PROCEDURE (external) statement [1187](#)
- ALTER PROCEDURE (SQL - external) statement [1193](#)
- AUTONOMOUS clause
- CREATE PROCEDURE (SQL - native) statement [1619](#)
- CREATE PROCEDURE (external) statement [1595](#)
- CREATE PROCEDURE (SQL - external) statement [1605](#)
- CREATE PROCEDURE (SQL - native) statement [1204](#), [1619](#)
- commit operations [42](#), [43](#), [55](#)
- commit processing [68](#)
- COMMIT statement
- description [1406](#)
- example [1409](#)
- COMMIT_ON_RETURN column
- SYSROUTINES catalog table [2621](#)
- common table expression [1069](#)
- communications database (CDB) [38](#)
- COMPARE_DECFLOAT function [421](#)

- comparison
 - array type values [166](#)
 - compatibility rules [143](#)
 - datetime values [158](#)
 - distinct type values [164](#)
 - numbers [156](#)
 - row ID values [159](#)
 - strings [157](#)
 - user-defined type values [164](#)
 - XML values [159](#)
- comparisons
 - string [157](#)
- compatibility
 - data types [143](#)
 - rules [143](#)
- COMPILE_OPTS column
 - SYSROUTINES_OPTS catalog table [2635](#)
- COMPONENT column
 - SYSIBM.XSRCOMPONENT table [2781](#)
 - SYSIBM.XSROBJECTCOMPONENTS table [2783](#)
 - SYSIBM.XSRPROPERTY table [2785](#)
- composite keys [10](#)
- compound statement
 - example [2221](#), [2286](#)
 - order of statements in [2221](#), [2286](#)
 - SQL procedure [2221](#), [2286](#)
- COMPRESS
 - clause of CREATE LOB TABLESPACE statement [1556](#)
 - clause of CREATE TABLESPACE statement [1728](#)
 - column of SYSTABLEPART catalog table [2665](#)
- COMPRESS clause
 - ALTER TABLESPACE statement [1325](#)
- COMPRESS column
 - SYSINDEXES catalog table [2461](#)
 - SYSTABLESPACE catalog table [2688](#)
- COMPRESS NO
 - clause of CREATE TABLE statement [1700](#)
- COMPRESS NO clause
 - ALTER INDEX statement [1167](#)
 - CREATE INDEX statement [1542](#)
- COMPRESS YES
 - clause of CREATE TABLE statement [1700](#)
- COMPRESS YES clause
 - ALTER INDEX statement [1167](#)
 - CREATE INDEX statement [1542](#)
- COMPRESSRATIO column
 - SYSTABLEPART catalog table [2665](#)
 - SYSTABLESPACE catalog table [2688](#)
- COMPRESSRATIION column
 - SYSTABLESPACE catalog table [2688](#)
- CONC_STMT column
 - SYSPACKAGE catalog table [2519](#)
- CONCAT
 - function [422](#)
 - operator [247](#)
- concatenation
 - CONCAT function [422](#)
 - operator [247](#)
- concepts [1](#)
- concurrency
 - LOCK TABLE statement [2017](#)
- CONCURRENT ACCESS RESOLUTION clause
 - CREATE PROCEDURE (SQL - native) statement [1125](#), [1206](#), [1352](#), [1440](#), [1621](#), [1750](#)
- condition
 - naming convention [84](#)
- CONNECT
 - option of precompiler [320](#)
 - statement [1409](#)
- connectable and connected state [72](#)
- connectable and unconnected state [72](#)
- connected state [71](#)
- connection
 - application process states [71](#), [72](#)
 - definition of [68](#)
 - initial state in distributed unit of work [69](#)
 - management in distributed unit of work [69](#)
 - management in remote unit of work [72](#)
 - SQL state
 - in a distributed unit of work [70](#)
 - state transitions [69](#)
 - when ended in a distributed unit of work [71](#)
- connection exit routine
 - description [207](#)
- connection state
 - SET CONNECTION statement [2122](#)
- constant
 - binary string [172](#)
 - datetime [174](#)
 - graphic string [173](#)
- CONSTNAME column
 - SYSKEYCOLUSE catalog table [2497](#)
 - SYSTABCONST catalog table [2664](#)
- constraint
 - naming convention [81](#)
- CONSTRAINT
 - clause of CREATE TABLE statement [1685](#)
- CONSTRAINT clause
 - ALTER TABLE statement [1267](#), [1269](#), [1272](#)
 - CREATE TABLE statement [1667](#), [1681](#), [1682](#)
- constraints
 - types [11](#)
- CONTAINS function [422](#)
- CONTAINS SQL clause
 - ALTER FUNCTION statement [1105](#)
 - ALTER PROCEDURE (external) statement [1185](#)
 - ALTER PROCEDURE (SQL - external) statement [1191](#)
 - ALTER PROCEDURE (SQL - native) statement [1203](#)
 - CREATE FUNCTION (inlined SQL scalar) statement [1496](#)
 - CREATE FUNCTION statement [1437](#), [1464](#), [1482](#)
 - CREATE PROCEDURE (external) statement [1591](#)
 - CREATE PROCEDURE (SQL - external) statement [1603](#)
 - CREATE PROCEDURE (SQL - native) statement [1618](#)
- context-name
 - naming convention [81](#)
- context-name clause
 - ALTER TRUSTED CONTEXT statement [1370](#)
 - CREATE TRUSTED CONTEXT statement [1789](#)
- CONTEXTID column
 - SYSCONTEXT catalog table [2401](#)
 - SYSCONTEXTAUTHIDS catalog table [2404](#)
 - SYSCTXTRUSTATTRS catalog table [2426](#)
- CONTINUE
 - clause of WHENEVER statement [2204](#)
- CONTINUE AFTER FAILURE clause
 - ALTER FUNCTION statement [1110](#)
 - ALTER PROCEDURE (external) statement [1188](#)
 - ALTER PROCEDURE (SQL - external) statement [1193](#)

CONTINUE AFTER FAILURE clause (*continued*)
 CREATE FUNCTION statement [1469, 1487](#)
 CREATE PROCEDURE (external) statement [1594](#)
 CREATE PROCEDURE (SQL - external) statement [1606](#)
 CONTINUE handler
 SQL procedure [2221, 2286](#)
 CONTOKEN
 column of SYSSEQUENCEAUTH catalog table [2640](#)
 CONTOKEN column
 SYSCOLAUTH catalog table [2371](#)
 SYSPACKAGE catalog table [2519](#)
 SYSPACKSTMT catalog table [2558](#)
 SYSPKSYSTEM catalog table [2574](#)
 SYSROUTINEAUTH catalog table [2619](#)
 SYSROUTINES catalog table [2621](#)
 SYSTABAUTH catalog table [2659](#)
 SYSVARIABLEAUTH catalog table [2722](#)
 control character [75](#)
 control statement [2207, 2279](#)
 CONVERT TO clause
 ALTER INDEX statement [1157](#)
 CONVLIMIT column of LUMODES catalog table
 description [2353](#)
 Coordinated Universal Time (UTC) [179](#)
 COPY
 clause of ALTER INDEX statement [1161](#)
 clause of CREATE INDEX statement [1546](#)
 COPY column
 SYSINDEXES catalog table [2461](#)
 COPY privilege
 GRANT statement [1975](#)
 REVOKE statement [2087](#)
 COPYAUTH column of SYSPACKAUTH catalog table [2536](#)
 COPYCHANGES column
 SYSINDEXSPACESTATS catalog table [2482](#)
 SYSTABLESPACESTATS catalog table [2699](#)
 COPYID
 column of SYSDYNQRY catalog table [2444](#)
 column of SYSDYNQRYDEP catalog table [2446](#)
 COPYLASTTIME column
 SYSINDEXSPACESTATS catalog table [2482](#)
 SYSTABLESPACESTATS catalog table [2699](#)
 COPYLRSN column
 SYSINDEXES catalog table [2461](#)
 COPYPAGESF column of SYSCOPY catalog table [2408](#)
 COPYUPDATEDPAGES column
 SYSINDEXSPACESTATS catalog table [2482](#)
 SYSTABLESPACESTATS catalog table [2699](#)
 COPYUPDATELRSN column
 SYSINDEXSPACESTATS catalog table [2482](#)
 SYSTABLESPACESTATS catalog table [2699](#)
 COPYUPDATELRSN_EX column
 SYSINDEXSPACESTATS catalog table [2482](#)
 SYSTABLESPACESTATS catalog table [2699](#)
 COPYUPDATETIME column
 SYSINDEXSPACESTATS catalog table [2482](#)
 SYSTABLESPACESTATS catalog table [2699](#)
 CORR
 function [358](#)
 correlated reference
 correlation name
 defining [220](#)
 FROM clause of subselect [1017](#)
 naming convention [81](#)
 correlated reference (*continued*)
 correlation name (*continued*)
 qualifying a column name [220](#)
 description [222](#)
 HAVING clause [1043](#)
 WHERE clause [1036](#)
 CORRELATION
 function [358](#)
 correlation-clause
 description [1028](#)
 COS function [425](#)
 COSH function [425](#)
 COUNT function [358](#)
 COUNT_BIG function [359](#)
 COVAR_POP
 function [360](#)
 COVAR_SAMP
 function [361](#)
 COVARIANCE
 function [360](#)
 COVARIANCE_SAMP
 function [361](#)
 CPAGESF column of SYSCOPY catalog table [2408](#)
 CREATE ALIAS statement
 description [1415](#)
 examples [1417](#)
 CREATE AUXILIARY TABLE statement
 description [1418](#)
 example [1420](#)
 CREATE DATABASE statement
 description [1421](#)
 example [1423](#)
 CREATE DISTINCT TYPE statement [23](#)
 CREATE FUNCTION (compiled SQL scalar) statement
 description [1428](#)
 example [1452](#)
 CREATE FUNCTION (external scalar) statement
 description [1453](#)
 example [1471](#)
 CREATE FUNCTION (external table) statement
 description [1472](#)
 example [1489](#)
 CREATE FUNCTION (inlined SQL scalar) statement
 description [1489](#)
 example [1498](#)
 CREATE FUNCTION (sourced) statement
 description [1498](#)
 example [1509](#)
 CREATE FUNCTION (SQL table) statement
 description [1510](#)
 examples [1517](#)
 CREATE FUNCTION statement [1424](#)
 CREATE GLOBAL TEMPORARY TABLE statement
 description [1518](#)
 example [1523](#)
 CREATE IN privilege
 binding a package [96](#)
 GRANT statement [1967](#)
 REVOKE statement [2076](#)
 CREATE INDEX statement
 description [1524](#)
 example [1552](#)
 CREATE MASK statement
 description [1562](#)

CREATE MASK statement (*continued*)
 examples [1568](#)

CREATE PERMISSION statement
 description [1571](#)
 examples [1577](#)

CREATE PROCEDURE (external) statement
 description [1580](#)
 example [1596](#)

CREATE PROCEDURE (SQL - external) statement
 description [1597](#)
 example [1606](#)

CREATE PROCEDURE (SQL - native) statement
 description [1607](#)
 examples [1636](#)

CREATE PROCEDURE statement
 assignment statement [2217](#), [2281](#)
 SQL procedure body [2212](#), [2280](#)

CREATE ROLE statement
 description [1637](#)
 example [1638](#)

CREATE SEQUENCE statement
 description [1638](#)
 example [1644](#)

CREATE STOGROUP statement
 example [1648](#)

CREATE SYNONYM statement
 description [1649](#)
 example [1650](#)

CREATE TABLE statement
 check constraints
 defining [27](#)
 DEFAULT clause [25](#)
 description [1650](#)
 example [1715](#)
 materialized query table [1650](#)
 NOT NULL clause [24](#)

CREATE TABLESPACE statement
 description [1718](#)
 example [1738](#)

CREATE TRIGGER statement
 description [1740](#), [1769](#)
 example [1764](#), [1784](#)

CREATE TRUSTED CONTEXT statement
 description [1787](#)
 example [1794](#)
 usage notes [1793](#)

CREATE TYPE (array) statement
 description [1795](#)
 example [1800](#)

CREATE TYPE (distinct) statement
 description [1801](#)
 example [1807](#)

CREATE TYPE statement
 description [1795](#)

CREATE VARIABLE statement
 description [1808](#)

CREATE VIEW statement
 description [1812](#)
 example [1818](#)

CREATE_DGTT procedure [916](#)

CREATE_SECURE_OBJECT privilege
 GRANT statement [1983](#)
 REVOKE statement [2097](#)

CREATEALIAS privilege
 GRANT statement [1983](#)
 REVOKE statement [2097](#)

CREATEALIASAUTH column of SYSUSERAUTH catalog table
[2715](#)

CREATEDBA privilege
 GRANT statement [1983](#)
 REVOKE statement [2097](#)

CREATEDBAAUTH column of SYSUSERAUTH catalog table
[2715](#)

CREATEDBC privilege
 GRANT statement [1983](#)
 REVOKE statement [2097](#)

CREATEDBCAUTH column of SYSUSERAUTH catalog table
[2715](#)

CREATEDBY column
 SYSDATABASE catalog table [2427](#)
 SYSDATATYPES catalog table [2429](#)
 SYSIBM.XSROBJECTS table [2782](#)
 SYSINDEXES catalog table [2461](#)
 SYSROUTINES catalog table [2621](#)
 SYSSEQUENCES catalog table [2643](#)
 SYSSTOGROUP catalog table [2655](#)
 SYSSYNONYMS catalog table [2658](#)
 SYSTABLES catalog table [2678](#)
 SYSTABLESPACE catalog table [2688](#)
 SYSTRIGGERS catalog table [2712](#)

CREATEDTS column
 SYSCOLUMNS catalog table [2381](#)
 SYSCONTEXT catalog table [2401](#)
 SYSCONTEXTAUTHIDS catalog table [2404](#)
 SYSTXTTRUSTATTRS catalog table [2426](#)
 SYSDATABASE catalog table [2427](#)
 SYSDATATYPES catalog table [2429](#)
 SYSIBM.XSROBJECTCOMPONENTS table [2783](#)
 SYSIBM.XSROBJECTS table [2782](#)
 SYSINDEXES catalog table [2461](#)
 SYSINDEXPART catalog table [2474](#)
 SYSJAROBJECTS catalog table [2495](#)
 SYSKEYTARGETS catalog table [2500](#)
 SYSROLES catalog table [2618](#)
 SYSROUTINES catalog table [2621](#)
 SYSSEQUENCES catalog table [2643](#)
 SYSSTOGROUP catalog table [2655](#)
 SYSSYNONYMS catalog table [2658](#)
 SYSTABCONST catalog table [2664](#)
 SYSTABLEPART catalog table [2665](#)
 SYSTABLES catalog table [2678](#)
 SYSTABLESPACE catalog table [2688](#)
 SYSTRIGGERS catalog table [2712](#)
 SYSVARIABLES catalog table [2724](#)
 SYSXMLRELS catalog table [2734](#)

CREATEIN privilege
 GRANT statement [1978](#)
 REVOKE statement [2091](#)

CREATEINAUTH column of SYSSCHEMAAUTH catalog table
[2638](#)

CREATESG privilege
 GRANT statement [1983](#)
 REVOKE statement [2097](#)

CREATESGAUTH column of SYSUSERAUTH catalog table
[2715](#)

CREATESTMT column
 SYSROUTINES_SRC catalog table [2637](#)

CREATETAB privilege
 GRANT statement [1968](#)
 REVOKE statement [2079](#)
 CREATETABAUTH column of SYSDBAUTH catalog table [2432](#)
 CREATETMTAB privilege
 GRANT statement [1983](#)
 REVOKE statement [2097](#)
 CREATETMTABAUTH column
 SYSUSERAUTH catalog table [2715](#)
 CREATETS
 column of DSNPROGAUTH table [2939](#)
 CREATETS privilege
 GRANT statement [1968](#)
 REVOKE statement [2079](#)
 CREATETSAUTH column of SYSDBAUTH catalog table [2432](#)
 CREATOR column
 DSNPROGAUTH table [2939](#)
 SYSCHECKS catalog table [2369](#)
 SYSCOLAUTH catalog table [2371](#)
 SYSDATABASE catalog table [2427](#)
 SYSFOREIGNKEYS catalog table [2458](#)
 SYSINDEXES catalog table [2461](#)
 SYSINDEXES_HIST catalog table [2472](#)
 SYSINDEXSPACESTATS catalog table [2482](#)
 SYSPACKAGE catalog table [2519](#)
 SYSPLAN catalog table [2575](#)
 SYSRELS catalog table [2613](#)
 SYSSTOGROUP catalog table [2655](#)
 SYSSYNONYMS catalog table [2658](#)
 SYSTABCONST catalog table [2664](#)
 SYSTABLES catalog table [2678](#)
 SYSTABLES_HIST catalog table [2707](#)
 SYSTABLESPACE catalog table [2688](#)
 SYSVIEWS catalog table [2730](#)
 CREATORTYPE column
 SYSDATABASE catalog table [2427](#)
 SYSPLAN catalog table [2575](#)
 SYSSTOGROUP catalog table [2655](#)
 SYSSYNONYMS catalog table [2658](#)
 SYSTABCONST catalog table [2664](#)
 SYSTABLESPACE catalog table [2688](#)
 CUBE clause
 examples [1054](#)
 CUME_DIST function [362](#)
 CURRENCY function [2945](#)
 CURRENT
 clause of RELEASE statement [2064](#)
 CURRENT ACCELERATOR special register
 description [184](#)
 CURRENT APPLICATION COMPATIBILITY special register
 description [184](#)
 CURRENT APPLICATION ENCODING SCHEME special register [185](#)
 CURRENT clause
 FETCH statement [1930](#)
 CURRENT CLIENT_ACCTNG special register [186](#)
 CURRENT CLIENT_APPLNAME special register [187](#)
 CURRENT CLIENT_CORR_TOKEN special register [189](#)
 CURRENT CLIENT_USERID special register [189](#)
 CURRENT CLIENT_WRKSTNNAME special register [190](#)
 current connection state [70](#)
 CURRENT DATA clause
 ALTER PROCEDURE (SQL - native) statement [1206](#)
 CURRENT DATA clause (*continued*)
 CREATE PROCEDURE (SQL - native) statement [1125](#),
 [1439](#), [1621](#)
 CREATE TRIGGER statement [1352](#), [1750](#)
 CURRENT DATE special register [192](#)
 CURRENT DEBUG MODE special register [192](#), [2133](#)
 CURRENT DECFLOAT ROUNDING MODE special register [193](#),
[2134](#)
 CURRENT DEGREE special register
 assigning a value [2136](#)
 description [194](#)
 setting [2136](#)
 CURRENT EXPLAIN MODE special register
 assigning a value [2137](#)
 description [194](#)
 setting [2137](#)
 CURRENT GET_ACCEL_ARCHIVE special register
 description [195](#)
 CURRENT LC_CTYPE special register
 description [196](#)
 CURRENT LOCALE LC_CTYPE special register
 assigning a value [2139](#)
 description [196](#)
 CURRENT MAINTAINED TABLE TYPES FOR OPTIMIZATION
 special register
 description [197](#)
 CURRENT MEMBER
 description [198](#)
 CURRENT OPTIMIZATION HINT special register
 assigning a value [2142](#)
 description [198](#)
 CURRENT PACKAGE PATH clause
 SET PATH statement [2164](#)
 CURRENT PACKAGE PATH special register
 description [199](#)
 CURRENT PACKAGESET special register
 assigning a value [2146](#)
 description [199](#)
 stored procedures [2147](#)
 CURRENT PATH clause
 SET PATH statement [2164](#)
 CURRENT PATH special register
 assigning a value [2163](#)
 description [200](#)
 CURRENT PRECISION special register
 assigning a value [2148](#)
 description [201](#)
 CURRENT QUERY ACCELERATION special register
 description [202](#)
 CURRENT QUERY ACCELERATION WAITFORDATA special register
 description [203](#)
 CURRENT REFRESH AGE special register
 description [204](#)
 CURRENT ROUTINE VERSION special register [204](#), [2154](#)
 CURRENT ROWSET clause
 FETCH statement [1934](#)
 CURRENT RULES special register
 assigning a value [2156](#)
 description [205](#)
 CURRENT SCHEMA special register
 assigning a value [2166](#)
 description [206](#)
 CURRENT SERVER special register

CURRENT SERVER special register (*continued*)
 description [207](#)

CURRENT SQLID special register
 assigning a value [2156](#)
 description [207](#)
 initial value [94](#)

CURRENT TEMPORAL BUSINESS_TIME special register
 assigning a value [2158](#)

CURRENT TEMPORAL SYSTEM_TIME special register
 assigning a value [2160](#)

CURRENT TIME special register
 description [211](#)

CURRENT TIMESTAMP special register
 description [212](#)

CURRENT TIMEZONE special register [213](#), [214](#)

CURRENT_SCHEMA column
 SYSENVIRONMENT catalog table [2452](#)

CURRENT_VERSION column
 SYSINDEXES catalog table [2461](#)
 SYSTABLESPACE catalog table [2688](#)

CURRENTSERVER
 column of SYSPLAN catalog table [2575](#)

cursor
 ASENSITIVE [1821](#)
 closed state [2039](#)
 closing
 CLOSE statement [1395](#)
 CONNECT statement [1409](#)
 error in FETCH [1941](#)
 error in UPDATE [2190](#)
 DYNAMIC [1821](#)
 INSENSITIVE [1821](#), [2045](#)
 naming convention [81](#)
 NO SCROLL [1821](#), [2046](#)
 open state [1941](#)
 opening
 errors [2039](#)
 OPEN statement [2037](#)
 rowset positioning [1824](#)
 rowset-positioning [2047](#)
 SCROLL [1821](#), [2046](#)
 SENSITIVE [1821](#)
 SENSITIVE DYNAMIC [2046](#)
 SENSITIVE STATIC [2046](#)
 STATIC [1822](#)
 using
 current row [1941](#)
 DECLARE CURSOR statement [1819](#)
 FETCH statement [1924](#)
 positions [1941](#)

cursor-name clause
 DECLARE CURSOR statement [1821](#)
 FETCH statement [1935](#)

CURSQLID
 column of SYSDYNQRY catalog table [2444](#)

CYCLE
 clause of ALTER SEQUENCE statement [1226](#)

CYCLE clause
 ALTER TABLE statement [1252](#)
 CREATE SEQUENCE statement [1641](#)

CYCLE column of SYSSEQUENCES catalog table [2643](#)

D

DATA CAPTURE clause
 ALTER TABLE statement [1288](#)
 CREATE TABLE statement [1698](#)

data compression
 COMPRESS clause
 ALTER TABLESPACE statement [1325](#)
 CREATE LOB TABLESPACE statement [1556](#)
 CREATE TABLESPACE statement [1728](#)

data structures
 databases [48](#)
 hash spaces [53](#)
 hierarchy [5](#)
 index spaces [51](#)
 indexes [29](#)
 keys [10](#)
 segments [51](#)
 table spaces [50](#)
 types [5](#)
 views [30](#)

data type
 array [127](#)
 built-in [98](#)
 cast from numeric [141](#)
 cast from string [142](#)
 casting between [130](#)
 character string [102](#)
 compatibility matrix [143](#)
 CREATE TABLE statement [1663](#)
 datetime [118](#)
 distinct [126](#)
 graphic string [112](#)
 list of built-in types [98](#)
 name, unqualified [86](#)
 naming convention
 built-in [80](#)
 distinct type [81](#)
 numeric [99](#)
 promotion [129](#)
 result column [1014](#)
 results of an operation [166](#)
 row ID [124](#)
 unqualified name [86](#)
 XML values [125](#)

DATA TYPE clause [1905](#)

data types
 BIGINT [19](#)
 BLOB [17](#), [22](#)
 built-in [16](#)
 CHAR [17](#), [20](#)
 CLOB [22](#)
 comparing [16](#)
 datetime [20](#)
 DBCLOB [22](#)
 distinct types [23](#)
 GRAPHIC [17](#)
 large object (LOB) [22](#)
 numeric [19](#)
 ROWID [22](#)
 SMALLINT [19](#)
 string
 encoding schemes [17](#)
 string subtypes [17](#)

data types (*continued*)
 VARCHAR
 compared to CHAR [17](#)
 VARGRAPHIC
 storage limit [22](#)
 XML [21](#)
 DATA_FORMAT column
 SYSENVIRONMENT catalog table [2452](#)
 DATA_SHARING_GROUP_NAME session variable [336](#)
 DATAACCESS privilege
 GRANT statement [1984](#)
 REVOKE statement [2097](#)
 database
 altering
 ALTER DATABASE statement [1095](#)
 creating [1421](#)
 default database [84](#)
 dropping [1892](#)
 DSNDB04 (default database) [84](#)
 DSNXSR (XML schema repository) [2780–2785](#)
 limits [2247](#)
 naming convention [81](#)
 privileges
 granting [1968](#)
 revoking [2078](#)
 DATABASE
 clause of GRANT statement [1969](#)
 clause of REVOKE statement [2079](#)
 DATABASE clause
 ALTER DATABASE statement [1095](#)
 DROP statement [1892](#)
 database descriptors
 contents [39](#)
 Database ExplorerQMF for Workstation [4](#)
 database request module (DBRM) [45](#), [57](#)
 databases
 creating [48](#)
 default databases [48](#)
 lock operations [48](#)
 overview [48](#)
 starting [48](#)
 stopping [48](#)
 users who need their own [48](#)
 DATACAPTURE column of SYSTABLES catalog table [2678](#)
 DATACLAS clause
 CREATE STOGROUP statement [1230](#), [1647](#)
 DATACLAS column
 SYSSTOGROUP catalog table [2655](#)
 DATAREPEATFACTORF column
 SYSINDEXES catalog table [2461](#)
 SYSINDEXES_HIST catalog table [2472](#)
 SYSINDEXESSTATS catalog table [2490](#)
 SYSINDEXESSTATS_HIST catalog table [2492](#)
 DATASIZE column
 SYSTABLESPACESTATS catalog table [2699](#)
 DATATYPEID column
 DATATYPES catalog table [2429](#)
 SYSCOLUMNS catalog table [2381](#)
 SYSKEYTARGETS catalog table [2500](#)
 SYSKEYTARGETS_HIST catalog table [2505](#)
 SYSPARMS catalog table [2565](#)
 SYSSEQUENCES catalog table [2643](#)
 SYSVARIABLES catalog table [2724](#)
 date
 date (*continued*)
 arithmetic [260](#)
 data type [118](#)
 duration [257](#)
 strings [120](#), [124](#)
 DATE
 data type
 CREATE TABLE statement [1663](#)
 function [425](#)
 DATE
 data type
 description [118](#)
 DATE data type [20](#)
 DATE FORMAT clause
 ALTER PROCEDURE (SQL - native) statement [1213](#)
 CREATE PROCEDURE (SQL - native) statement [1131](#),
 [1445](#), [1629](#)
 CREATE TRIGGER statement [1356](#), [1754](#)
 DATE FORMAT field of panel DSNTIP4 [325](#)
 date routine
 CHAR function [405](#)
 DATE_FORMAT session variable [336](#)
 DATE_LENGTH session variable [336](#)
 datetime
 arithmetic [259](#)
 constants [174](#)
 data types
 description [118](#)
 string representation [120](#)
 EUR (IBM European standard) [120](#)
 format
 setting through the CHAR function [405](#)
 ISO (International Standards Organization) [120](#)
 JIS (Japanese Industrial Standard) [120](#)
 LOCAL [120](#)
 operands [169](#)
 string formats [120](#)
 USA [120](#)
 datetime data types [20](#)
 datetime host variables
 data type
 description [120](#)
 DAY column
 SYSINDEXCONTROL catalog table [2460](#)
 DAY function [426](#)
 day of week calculation [432](#)
 DAYNAME function [2946](#)
 DAYOFMONTH function [428](#)
 DAYOFWEEK function [429](#)
 DAYOFWEEK_ISO function [430](#)
 DAYOFYEAR function [431](#)
 DAYS function [432](#)
 DAYS_BETWEEN scalar function [433](#)
 DB2 databases [48](#)
 Db2 private protocol access
 authorization ID [96](#)
 Db2 Query Management Facility (QMF) [48](#)
 Db2 Query Management Facility (QMF)QMF for Workstation
 [4](#)
 Db2 subsystem
 local [68](#)
 Db2-defined defaults [25](#)
 Db2-supplied
 stored procedures [699](#)

DBADM authority
 GRANT statement [1968](#)
 REVOKE statement [2078](#)

DBADM privilege
 GRANT statement [1984](#)
 REVOKE statement [2097](#)

DBADMAUTH column of SYSDBAUTH catalog table [2432](#)

DBALIAS column
 LOCATIONS catalog table [2351](#)

DBCLOB
 function [434](#)
 LOB data type [22](#)

DBCLOB (double-byte character large object)
 data type [112](#), [1663](#)
 description [116](#)
 file reference [232](#)
 locator [230](#)
 variable [230](#)

DBCS (double-byte character set)
 ASCII [104](#)
 EBCDIC [104](#)
 SQL ordinary identifier [75](#), [77](#)
 Unicode [104](#)

DBCS_CCSID column
 SYSDATABASE catalog table [2427](#)
 SYSTABLESPACE catalog table [2688](#)

DBCTRL authority
 GRANT statement [1968](#)
 REVOKE statement [2078](#)

DBCTRLAUTH column of SYSDBAUTH catalog table [2432](#)

DBD01 directory table space
 contents [39](#)

DBID
 column of SYSCHECKS catalog table [2369](#)
 column of SYSDATABASE catalog table [2427](#)
 column of SYSTABLES catalog table [2678](#)
 column of SYSTABLESPACE catalog table [2688](#)
 column of SYSTRIGGERS catalog table [2712](#)

DBID column
 SYSINDEXES catalog table [2461](#)
 SYSINDEXSPACESTATS catalog table [2482](#)
 SYSTABLESPACESTATS catalog table [2699](#)

DBINFO
 clause of ALTER FUNCTION statement [1108](#)
 clause of CREATE FUNCTION statement [1467](#), [1485](#)
 column of SYSROUTINES catalog table [2621](#)

DBINFO clause
 ALTER PROCEDURE (external) statement [1185](#)
 CREATE PROCEDURE (external) statement [1592](#)

DBMAINT authority
 GRANT statement [1968](#)
 REVOKE statement [2079](#)

DBMAINTAUTH column of SYSDBAUTH catalog table [2432](#)

DBNAME
 column of SYSDYNQRYDEP catalog table [2446](#)

DBNAME column
 SYSCOPY catalog table [2408](#)
 SYSINDEXES catalog table [2461](#)
 SYSINDEXSPACESTATS catalog table [2482](#)
 SYSLOBSTATS catalog table [2516](#)
 SYSLOBSTATS_HIST catalog table [2516](#)
 SYSTABAUTH catalog table [2659](#)
 SYSTABLEPART catalog table [2665](#)
 SYSTABLEPART_HIST catalog table [2675](#)

DBNAME column (*continued*)
 SYSTABLES catalog table [2678](#)
 SYSTABLES_HIST catalog table [2707](#)
 SYSTABLESPACE catalog table [2688](#)
 SYSTABLESPACESTATS catalog table [2699](#)
 SYSTABSTATS catalog table [2710](#)
 SYSTABSTATS_HIST catalog table [2711](#)

DBPROTOCOL column
 SYSPACKAGE catalog table [2519](#)
 SYSPLAN catalog table [2575](#)

DBRMLIB column of SYSJAVAOPTS catalog table [2496](#)

DCLGEN subcommand of DSN
 description [118](#)

DCOLLID column of SYSPACKDEP catalog table [2554](#)

DCOLNAME column
 SYSDependencies catalog table [2439](#)

DCOLNAME column of SYSSEQUENCEDEP catalog table [2646](#)

DCOLNO column
 SYSDependencies catalog table [2439](#)

DCONSTNAME column of SYSCONSTDEP catalog table [2400](#)

DCONTOKEN column of SYSPACKDEP catalog table [2554](#)

DCREATOR column
 SYSSEQUENCEDEP catalog table [2646](#)
 SYSVIEWDEP catalog table [2729](#)

DDCS (data definition control support)
 database [41](#)

deadlocks
 locks [43](#), [55](#)
 uncommitted changes [43](#), [55](#)

DEBUG_MODE column
 SYSROUTINES catalog table [2621](#)
 SYSROUTINES_OPTS catalog table [2635](#)
 SYSTRIGGERS catalog table [2712](#)

DEBUGSESSION privilege
 GRANT statement [1984](#)
 REVOKE statement [2098](#)

DEBUGSESSIONAUTH column
 SYSUSERAUTH catalog table [2715](#)

DEC function [441](#)

DEC15 precompiler option [250](#)

DEC31
 column of SYSDBRM catalog table [2437](#)
 column of SYSPACKAGE catalog table [2519](#)
 precompiler option [250](#)

DECFLOAT
 data type
 CREATE TABLE statement [1663](#)
 rounding mode [323](#)

DECFLOAT data type [19](#)

DECFLOAT function [437](#)

DECFLOAT_FORMAT function [438](#)

DECFLOAT_SORTKEY function [440](#)

DECIMAL
 data type
 CREATE TABLE statement [1663](#)
 function
 description [441](#)

DECIMAL clause
 ALTER PROCEDURE (SQL - native) statement [1213](#)
 CREATE PROCEDURE (SQL - native) statement [1131](#), [1446](#), [1629](#)
 CREATE TRIGGER statement [1356](#), [1754](#)

DECIMAL data type [19](#)

decimal division [250](#)
 DECIMAL POINT IS field of panel DSNTIPF [323](#)
 decimal point precompiler option [323](#)
 DECIMAL_ARITHMETIC column
 SYSENVIRONMENT catalog table [2452](#)
 DECIMAL_ARITHMETIC session variable [336](#)
 DECIMAL_POINT column
 SYSENVIRONMENT catalog table [2452](#)
 DECIMAL_POINT session variable [336](#)
 DECLARE CURSOR statement
 description [1819](#)
 example [1819](#)
 declare default element namespace clause
 CREATE INDEX statement [1534](#)
 DECLARE GLOBAL TEMPORARY TABLE statement
 description [1830](#)
 example [1843](#)
 declare namespace clause
 CREATE INDEX statement [1534](#)
 DECLARE STATEMENT statement
 description [1844](#)
 example [1844](#)
 DECLARE TABLE statement
 description [1845](#)
 example [1850](#)
 DECLARE VARIABLE statement
 description [1850](#)
 example [1852](#)
 DECODE function [443](#)
 DECOMPOSITION column
 SYSIBM.XSROBJECTS table [2782](#)
 DECOMPOSITION_VERSION column
 SYSIBM.XSROBJECTS table [2782](#)
 decrementing time [261](#)
 DECRYPT_BINARY function [444](#)
 DECRYPT_BIT function [444](#)
 DECRYPT_CHAR function [444](#)
 DECRYPT_DATAKEY_BIGINT function [446](#)
 DECRYPT_DATAKEY_BIT function [446](#)
 DECRYPT_DATAKEY_CLOB function [446](#)
 DECRYPT_DATAKEY_DBCLOB function [446](#)
 DECRYPT_DATAKEY_DECIMAL function [446](#)
 DECRYPT_DATAKEY_INTEGER function [446](#)
 DECRYPT_DATAKEY_VARCHAR function [446](#)
 DECRYPT_DATAKEY_VARGRAPHIC function [446](#)
 DECRYPT_DB function [444](#)
 DEFAULT clause
 ALTER TABLE statement [1248](#)
 DEFAULT column
 SYSCOLUMNS catalog table [2381](#)
 SYSVARIABLES catalog table [2724](#)
 default database (DSNDB04)
 defining [48](#)
 implicit specification [84](#)
 DEFAULT REGISTERS clause
 ALTER PROCEDURE (external) statement [1188](#)
 ALTER PROCEDURE (SQL - external) statement [1193](#)
 ALTER PROCEDURE (SQL - native) statement [1205](#)
 CREATE PROCEDURE (SQL - external) statement [1606](#)
 CREATE PROCEDURE (SQL - native) statement [1125](#),
 [1439](#), [1620](#)
 DEFAULT ROLE clause
 ALTER TRUSTED CONTEXT statement [1371](#)
 CREATE TRUSTED CONTEXT statement [1789](#)
 DEFAULT SECURITY LABEL clause
 ALTER TRUSTED CONTEXT statement [1372](#)
 CREATE TRUSTED CONTEXT statement [1790](#)
 DEFAULT SPECIAL REGISTERS clause
 ALTER FUNCTION statement [1111](#)
 CREATE FUNCTION statement [1470](#), [1487](#)
 CREATE PROCEDURE (external) statement [1595](#)
 default values
 compared to null values [26](#)
 Db2-defined defaults [25](#)
 ROWID data type [25](#)
 user-defined default values [25](#)
 DEFAULT_DECFLOAT_ROUND_MODE session variable [336](#)
 DEFAULT_DEFAULT_SSID session variable [336](#)
 DEFAULT_LANGUAGE session variable [336](#)
 DEFAULT_LOCALE_LC_CTYPE session variable [336](#)
 DEFAULT_SQLLEVEL
 built-in global variable [330](#)
 DEFAULTROLE column
 SYSCONTEXT catalog table [2401](#)
 DEFAULTSECURITYLABEL column
 SYSCONTEXT catalog table [2401](#)
 DEFAULTTEXT column
 SYSVARIABLES catalog table [2724](#)
 DEFAULTVALUE column of SYSCOLUMNS catalog table [2381](#)
 DEFER
 clause of CREATE INDEX statement [1544](#)
 DEFER PREPARE clause
 ALTER PROCEDURE (SQL - native) statement [1205](#)
 CREATE PROCEDURE (SQL - native) statement [1620](#)
 DEFERPREP column
 SYSPACKAGE catalog table [2519](#)
 SYSPLAN catalog table [2575](#)
 DEFERPREPARE column of SYSPACKAGE catalog table [2519](#)
 deferred embedded SQL [2](#)
 define behavior for dynamic SQL statements [94](#)
 DEFINE clause
 CREATE INDEX statement [1541](#)
 CREATE LOB TABLESPACE statement [1557](#)
 CREATE TABLESPACE statement [1728](#)
 DEFINER column
 SYSCONTEXT catalog table [2401](#)
 SYSOBJROLEDEP catalog table [2517](#)
 SYSROLES catalog table [2618](#)
 DEFINERTYPE column
 SYSCONTEXT catalog table [2401](#)
 SYSOBJROLEDEP catalog table [2517](#)
 SYSROLES catalog table [2618](#)
 DEFINITION ONLY clause
 CREATE TABLE statement [1714](#)
 DECLARE GLOBAL TEMPORARY TABLE statement [1843](#)
 DEGREE
 column of SYSPACKAGE catalog table [2519](#)
 column of SYSPLAN catalog table [2575](#)
 DEGREE clause
 ALTER PROCEDURE (SQL - native) statement [1206](#)
 CREATE PROCEDURE (SQL - native) statement [1125](#),
 [1439](#), [1621](#)
 DEGREES function [449](#)
 DELETE
 clause of TRIGGER statement [1348](#), [1756](#), [1776](#)
 statement
 description [1853](#)
 example [1868](#)

DELETE privilege
 GRANT statement [1988](#)
 REVOKE statement [2101](#)
 delete rules [1864](#)
 DELETEAUTH column of SYSTABAUTH catalog table [2659](#)
 DELETERULE column of SYSRELS catalog table [2613](#)
 deleting
 all rows from a table [2175](#)
 rows from a table [1853](#)
 SQL objects [1886](#)
 delimited identifier in SQL [77](#)
 delimiter
 SQL [77](#)
 DENSE_RANK expression [280](#)
 DENSERANK expression [280](#)
 dependency
 of objects on each other [1902](#)
 dependent rows [12](#)
 dependent tables [12](#)
 DERIVED_FROM column
 SYSKEYTARGETS catalog table [2500](#)
 DESC clause
 ALTER TABLE statement [1275](#)
 CREATE INDEX statement [1532](#)
 CREATE TABLE statement [1695](#)
 select-statement [1045](#)
 DESCRIBE CURSOR statement
 description [1869](#)
 example [1871](#)
 DESCRIBE INPUT statement
 prepared statement [1871](#)
 DESCRIBE OUTPUT statement [1873](#)
 DESCRIBE PROCEDURE statement
 description [1879](#)
 example [1880](#)
 DESCRIBE statement
 variables [1873](#), [1882](#)
 DESCRIBE TABLE statement [1881](#)
 descriptor
 naming convention [81](#)
 DESCRIPTOR column
 SYSVARIABLES catalog table [2724](#)
 DESCSTAT column
 SYSPACKAGE catalog table [2519](#)
 DETERMINISTIC clause
 ALTER FUNCTION statement [1104](#), [1122](#), [1147](#)
 ALTER PROCEDURE (external) statement [1184](#)
 ALTER PROCEDURE (SQL - external) statement [1191](#)
 ALTER PROCEDURE (SQL - native) statement [1203](#)
 CREATE FUNCTION (inlined SQL scalar) statement [1495](#)
 CREATE FUNCTION statement [1436](#), [1463](#), [1481](#)
 CREATE PROCEDURE (external) statement [1592](#)
 CREATE PROCEDURE (SQL - external) statement [1603](#)
 CREATE PROCEDURE (SQL - native) statement [1618](#)
 DETERMINISTIC column of SYSROUTINES catalog table [2621](#)
 DEVTYPE column of SYSCOPY catalog table [2408](#)
 DFSMSHsm (Data Facility Hierarchical Storage Manager)
 dropping an index or table space [1902](#)
 DIFFERENCE function [450](#)
 digit, description in DB2 [75](#)
 DIGITS function [450](#)
 directory
 table space names [39](#)
 directory tables
 description [2769](#)
 indexes [2770](#)
 table space [2770](#)
 directory, Db2
 formats
 SYSIBM.DRDR [2771](#)
 SYSIBM.SCTR [2771](#)
 SYSIBM.SPTR [2771](#)
 SYSIBM.SYSDBD_DATA [2771](#)
 SYSIBM.SYSLGRNX [2772](#)
 SYSIBM.SYSSPTSEC_DATA [2772](#)
 SYSIBM.SYSSPTSEC_EXPL [2772](#)
 SYSIBM.SYSUTIL [2773](#)
 SYSIBM.SYSUTILX [2776](#)
 directory, DB2
 SYSUTIL [2773](#)
 SYSUTILX [2776](#)
 tables [2769](#)
 disability xxv
 DISABLE ARCHIVE clause
 ALTER TABLE statement [1294](#)
 DISABLE clause
 ALTER TRUSTED CONTEXT statement [1371](#)
 CREATE TRUSTED CONTEXT statement [1790](#)
 DISABLE DEBUG MODE clause
 ALTER PROCEDURE (external) statement [1188](#)
 ALTER PROCEDURE (SQL - native) statement [1203](#)
 CREATE PROCEDURE (external) statement [1588](#)
 CREATE PROCEDURE (SQL - native) statement [1124](#),
 [1438](#), [1618](#)
 DISABLE procedure [917](#)
 DISALLOW DEBUG MODE clause
 ALTER PROCEDURE (external) statement [1188](#)
 ALTER PROCEDURE (SQL - native) statement [1203](#)
 CREATE PROCEDURE (external) statement [1588](#)
 CREATE PROCEDURE (SQL - native) statement [1124](#),
 [1438](#), [1618](#)
 DISALLOW PARALLEL clause
 ALTER FUNCTION statement [1108](#)
 CREATE FUNCTION statement [1467](#), [1485](#)
 DISCONNECT
 column of SYSPLAN catalog table [2575](#)
 DISPLAY privilege
 GRANT statement [1984](#)
 REVOKE statement [2097](#)
 DISPLAYAUTH column of SYSUSERAUTH catalog table [2715](#)
 DISPLAYDB privilege
 GRANT statement [1969](#)
 REVOKE statement [2079](#)
 DISPLAYDBAUTH column of SYSDBAUTH catalog table [2432](#)
 DISTINCT
 clause of subselect [1010](#)
 keyword
 AVG function [357](#)
 COUNT function [358](#)
 COUNT_BIG function [359](#)
 MAX function [367](#)
 MIN function [369](#)
 STDDEV_POP function [376](#)
 STDDEV_SAMP function [377](#)
 SUM function [378](#)
 VAR_POP function [379](#)
 VARIANCE_SAMP function [380](#)

DISTINCT predicate [304](#)
 distinct type
 casting [130](#)
 comparison of values [164](#)
 CREATE TABLE statement [1667](#)
 creating [1801](#)
 description [126](#)
 granting privileges [1991](#)
 name, unqualified [81](#), [86](#)
 naming convention [81](#)
 promotion [129](#)
 revoking privileges [2104](#)
 unqualified name [86](#)
 distinct types [23](#)
 distributed access
 restriction [77](#)
 distributed data
 CONNECT statement [1409](#)
 CURRENT SERVER special register [207](#)
 RELEASE (connection) statement [2063](#)
 SET CONNECTION statement [2122](#)
 distributed relational database
 definition of [68](#)
 Distributed Relational Database Architecture (DRDA) [68](#)
 distributed unit of work
 connection management [69](#)
 definition of [69](#)
 DISTRIBUTED_SQL_STRING_DELIMITER session variable [336](#)
 DLOCATION column of SYSPACKDEP catalog table [2554](#)
 DNAME column
 SYSDEPENDENCIES catalog table [2439](#)
 SYSOBJROLEDEP catalog table [2517](#)
 SYSPACKDEP catalog table [2554](#)
 SYSPLANDEP catalog table [2584](#)
 SYSSEQUENCEDEP catalog table [2646](#)
 SYSVIEWDEP catalog table [2729](#)
 dormant connection state [70](#)
 DOUBLE data type
 CREATE TABLE statement [1663](#)
 DOUBLE function [451](#)
 DOUBLE or DOUBLE_PRECISION
 function [451](#)
 DOUBLE PRECISION data type
 CREATE TABLE statement [1663](#)
 DOUBLE_PRECISION function [451](#)
 double-byte character
 LABEL statement [2016](#)
 truncated during assignment [150](#)
 double-byte character large object (DBCLOB) [116](#)
 double-byte character set (DBCS) [17](#)
 DOWNER column
 SYSDEPENDENCIES catalog table [2439](#)
 SYSVIEWDEP catalog table [2729](#)
 DOWNER column of SYSPACKDEP catalog table [2554](#)
 DOWNERTYPE column
 SYSDEPENDENCIES catalog table [2439](#)
 SYSPACKDEP catalog table [2554](#)
 DRDA access
 authorization ID [96](#)
 mixed environment [2269](#)
 DROP ATTRIBUTES clause
 ALTER TRUSTED CONTEXT statement [1373](#)
 DROP CHECK clause
 ALTER TABLE statement [1274](#)
 DROP CHECK clause (*continued*)
 ALTER TABLE statement [1274](#)
 DROP CLONE clause
 ALTER TABLE statement [1289](#)
 DROP CONSTRAINT clause
 ALTER TABLE statement [1274](#)
 DROP FOREIGN KEY clause
 ALTER TABLE statement [1274](#)
 DROP MATERIALIZED QUERY clause
 ALTER TABLE statement [1288](#)
 DROP PENDING CHANGES clause
 ALTER TABLESPACE statement [1326](#)
 DROP PRIMARY KEY clause
 ALTER TABLE statement [1274](#)
 DROP privilege
 GRANT statement [1969](#)
 REVOKE statement [2079](#)
 DROP RESTRICT ON DROP clause
 ALTER TABLE statement [1290](#)
 DROP statement
 description [1886](#)
 example [1905](#)
 DROP STORAGE clause
 TRUNCATE statement [2176](#)
 DROP UNIQUE clause
 ALTER TABLE statement [1274](#)
 DROP USE FOR clause
 ALTER TRUSTED CONTEXT statement [1376](#)
 DROP VERSION clause
 ALTER PROCEDURE (SQL - native) statement [1202](#)
 DROPAUTH column of SYSDBAUTH catalog table [2432](#)
 DROPIN privilege
 GRANT statement [1978](#)
 REVOKE statement [2091](#)
 DROPINAUTH column of SYSCHEMAAUTH catalog table [2638](#)
 DSCHEMA column
 SYSDEPENDENCIES catalog table [2439](#)
 SYSOBJROLEDEP catalog table [2517](#)
 DSCHEMA column of SYSSEQUENCEDEP catalog table [2646](#)
 DSN_DET_COST_TABLE
 columns [2817](#)
 DSN_FILTER_TABLE
 columns [2827](#)
 DSN_FUNCTION_TABLE
 column descriptions [2832](#)
 DSN_PGRANGE_TABLE
 columns [2844](#)
 DSN_PGGROUP_TABLE
 columns [2848](#)
 DSN_PREDICATE_SELECTIVITY
 column descriptions [2863](#)
 DSN_PREDICATE_TABLE
 columns [2855](#)
 DSN_PTASK_TABLE
 columns [2869](#)
 DSN_QUERY_TABLE
 columns [2882](#)
 DSN_QUERYINFO_TABLE
 EXPLAIN table [2874](#)
 DSN_SORT_TABLE
 columns [2891](#)
 DSN_SORTKEY_TABLE
 columns [2885](#)

DSN_STRUCT_TABLE
 columns [2920](#)
 DSN_VIEWREF_TABLE
 columns [2926](#)
 DSN_WLM_APPLENV procedure [913](#)
 DSN_XMLVALIDATE function [452](#)
 DSNACCOX stored procedure
 description [848](#)
 option descriptions [852](#)
 output [870](#)
 syntax diagram [850](#)
 DSNACICS stored procedure [880](#)
 DSNAIMS stored procedure [885](#)
 DSNAIMS2 stored procedure [889](#)
 DSNAME
 column of SYSCOPY catalog table [2408](#)
 DSNDB04 default database [48](#)
 DSNHDECP_NAME session variable [336](#)
 DSNLEUSR stored procedure [893](#)
 DSNUM column
 SYSCOPY catalog table [2408](#)
 SYSINDEXPART catalog table [2474](#)
 SYSINDEXPART_HIST catalog table [2480](#)
 SYSTABLEPART catalog table [2665](#)
 SYSTABLEPART_HIST catalog table [2675](#)
 DSNUTILS stored procedure
 authorization required [897](#)
 data sets [897](#)
 description [895](#)
 option descriptions [899](#)
 output [906](#)
 restarting a utility [895](#)
 sample JCL [905](#)
 syntax diagram [899](#)
 terminating a utility [895](#)
 DSNUTILU stored procedure
 authorization required [907](#)
 data sets [907](#)
 description [906](#)
 option descriptions [908](#)
 output [909](#)
 restarting a utility [906](#)
 sample JCL [909](#)
 syntax diagram [908](#)
 DSNUTILV stored procedure
 authorization required [911](#)
 data sets [911](#)
 description [910](#)
 option descriptions [911](#)
 output [913](#)
 restarting a utility [910](#)
 sample JCL [913](#)
 syntax diagram [911](#)
 DSNXSR database
 SYSIBM.XSRANNOTATIONINFO table [2780](#)
 SYSIBM.XSRCOMPONENT table [2781](#)
 SYSIBM.XSROBJECTCOMPONENTS table [2783](#)
 SYSIBM.XSROBJECTGRAMMAR table [2784](#)
 SYSIBM.XSROBJECTHIERARCHIES table [2784](#)
 SYSIBM.XSROBJECTPROPERTY table [2785](#)
 SYSIBM.XSROBJECTS table [2782](#)
 SYSIBM.XSRPROPERTY table [2785](#)
 DSSIZE
 clause of CREATE INDEX statement [1161](#), [1544](#)
 DSSIZE (*continued*)
 clause of CREATE LOB TABLESPACE statement [1557](#)
 clause of CREATE TABLE statement [1701](#)
 DSSIZE clause
 ALTER TABLESPACE statement [1326](#)
 DSSIZE column
 SYSINDEXES catalog table [2461](#)
 SYSTABLESPACE catalog table [2688](#)
 DSVOLSER column of SYSCOPY catalog table [2408](#)
 DTBCREATOR column of SYSCONSTDEP catalog table [2400](#)
 DTBNAME column of SYSCONSTDEP catalog table [2400](#)
 DTBOWNER column
 SYSCONSTDEP catalog table [2400](#)
 DTYPE column
 SYSCONSTDEP catalog table [2400](#)
 SYSDEPENDENCIES catalog table [2439](#)
 SYSOBJROLEDEP catalog table [2517](#)
 SYSPACKDEP catalog table [2554](#)
 SYSVIEWDEP catalog table [2729](#)
 DTYPE column of SYSSEQUENCEDEP catalog table [2646](#)
 dual logging [40](#)
 duplicate rows, UNION clause [1061](#)
 duration
 date [257](#)
 labeled [257](#)
 time [257](#)
 timestamp [257](#)
 DYNAMIC clause
 DECLARE CURSOR statement [1821](#)
 DYNAMIC RESULT SET clause
 ALTER PROCEDURE (external) statement [1182](#)
 ALTER PROCEDURE (SQL - native) statement [1203](#)
 CREATE PROCEDURE (SQL - external) statement [1602](#)
 CREATE PROCEDURE (SQL - native) statement [1618](#)
 DYNAMIC RESULT SETS clause
 ALTER PROCEDURE (SQL - external) statement [1191](#)
 CREATE PROCEDURE (external) statement [1588](#)
 dynamic SQL
 description [2](#), [1086](#)
 DYNAMICRULES bind option [94](#)
 EXECUTE IMMEDIATE statement [1914](#)
 EXECUTE statement [1909](#)
 execution [1088](#)
 INTO clause
 DESCRIBE statement [1873](#)
 PREPARE statement [2044](#)
 invocation of SELECT statement [1089](#)
 preparation [1088](#)
 SQLDA [2313](#)
 statements allowed [2269](#)
 DYNAMIC_RULES session variable [336](#)
 DYNAMICRULES
 column of SYSPACKAGE catalog table [2519](#)
 column of SYSPLAN catalog table [2575](#)
 dynamic SQL authorization [94](#)
 option [86](#)
 unqualified names [86](#)
 DYNAMICRULES behavior [94](#)
 DYNAMICRULES clause
 ALTER PROCEDURE (SQL - native) statement [1207](#)
 CREATE PROCEDURE (SQL - native) statement [1126](#),
 [1440](#), [1621](#)
 CREATE TRIGGER statement [1352](#), [1751](#)

E

- EBCDIC
 - definition [59](#)
 - effect on MBCS and DBCS characters [104](#)
 - encoding schemes [17](#)
- EBCDIC CCSID field of panel DSNTIPF [325](#)
- EBCDIC_CHR function [453](#)
- EBCDIC_STR function [453](#)
- edit routine
 - named in CREATE TABLE statement [1697](#)
 - specified by EDITPROC option [1697](#)
- EDITPROC clause
 - CREATE TABLE statement [1697](#)
- EDPROC column of SYSTABLES catalog table [2678](#)
- ENABLE
 - column of SYSPKSYSTEM catalog table [2574](#)
 - column of SYSPLSYSTEM catalog table [2586](#)
- ENABLE ARCHIVE clause
 - ALTER TABLE statement [1293](#)
- ENABLE clause
 - ALTER TRUSTED CONTEXT statement [1371](#)
 - CREATE TRUSTED CONTEXT statement [1790](#)
- ENABLE column
 - SYSVIEWS catalog table [2730](#)
- ENABLE procedure [918](#)
- ENABLE QUERY OPTIMIZATION clause
 - ALTER TABLE statement [1272](#)
 - CREATE TABLE statement [1685](#)
- ENABLED
 - column of DSNPROGAUTH table [2939](#)
- ENABLED column
 - SYSCONTEXT catalog table [2401](#)
- encoding scheme
 - of strings [63](#)
- encoding schemes
 - ASCII [17](#)
 - EBCDIC [17](#)
 - Unicode [17](#)
- ENCODING_CCSID column
 - SYSPACKAGE catalog table [2519](#)
 - SYSPLAN catalog table [2575](#)
- ENCODING_SCHEME column
 - SYSCOLUMNS catalog table [2381](#)
 - SYSDATABASE catalog table [2427](#)
 - SYSDATATYPES catalog table [2429](#)
 - SYSPARMS catalog table [2565](#)
 - SYSTABLES catalog table [2678](#)
 - SYSTABLESPACE catalog table [2688](#)
- ENCODING_SCHEME session variable [336](#)
- ENCRYPT function [454](#), [456](#)
- ENCRYPT_DATAKEY function [454](#)
- ENCRYPT_TDES function [456](#)
- encryption [1791](#)
- ENCRYPTION clause
 - ALTER TRUSTED CONTEXT statement [1372](#)
 - CREATE TRUSTED CONTEXT statement [1791](#)
- encryption password [2161](#)
- ENCRYPTION PASSWORD special register [213](#)
- ENCRYPTPSWDS column of LUNAMES catalog table [2354](#)
- END DECLARE SECTION statement
 - description [1907](#)
 - example [1907](#)
- ENDING AT clause
 - ALTER INDEX statement [1170](#)
 - ALTER TABLE statement [1275](#), [1278](#)
 - CREATE INDEX statement [1543](#)
 - CREATE TABLE statement [1696](#)
- ENFORCED clause
 - ALTER TABLE statement [1272](#)
 - CREATE TABLE statement [1685](#)
- ENFORCED column
 - SYSRELS catalog table [2613](#)
- ENFORCED_CONS column
 - SYSINDEXES catalog table [2461](#)
- entity integrity [12](#)
- ENVID column
 - SYSENVIRONMENT catalog table [2452](#)
 - SYSINDEXES catalog table [2461](#)
 - SYSTRIGGERS catalog table [2712](#)
 - SYSVARIABLES catalog table [2724](#)
- EPOCH column of SYSTABLEPART catalog table [2665](#)
- ERASE clause
 - ALTER INDEX statement [1164](#)
 - ALTER TABLESPACE statement [1334](#)
 - CREATE INDEX statement [1539](#)
- ERASERULE column
 - SYSINDEXES catalog table [2461](#)
 - SYSTABLESPACE catalog table [2688](#)
- error
 - closes cursor [2039](#)
 - during FETCH [1941](#)
 - during update [2190](#)
 - signaling [2169](#)
- ERRORBYTE column of SYSSTRINGS catalog table [2656](#)
- ESCAPE clause
 - LIKE predicate [308](#)
- evaluation order [263](#)
- EXCEPT clause [1061](#)
- EXCEPTION clause [1962](#)
- EXCHANGE statement
 - description [1908](#)
 - example [1908](#)
- EXCLUDING COLUMN DEFAULTS clause
 - CREATE TABLE statement [1689](#)
 - DECLARE GLOBAL TEMPORARY TABLE statement [1838](#)
- EXCLUDING IDENTITY COLUMN ATTRIBUTES clause
 - CREATE TABLE statement [1688](#)
 - DECLARE GLOBAL TEMPORARY TABLE statement [1837](#)
- EXCLUDING ROW CHANGE TIMESTAMP COLUMN ATTRIBUTES clause
 - CREATE TABLE statement [1688](#)
- EXCLUSIVE
 - option of LOCK TABLE statement [2017](#)
- exclusive dependence [2072](#)
- executable statement [1086](#), [1087](#)
- EXECUTE IMMEDIATE statement
 - description [1914](#)
 - example [1916](#)
- EXECUTE privilege
 - GRANT statement [1973](#), [1975](#), [1977](#)
 - REVOKE statement [2084](#), [2087](#), [2089](#)
- EXECUTE statement
 - description [1909](#)
 - example [1913](#)
- EXECUTEAUTH column
 - SYSPACKAUTH catalog table [2536](#)

EXECUTEAUTH column (*continued*)
 SYSPLANAUTH catalog table [2582](#)
 SYSROUTINEAUTH catalog table [2619](#)

EXISTS predicate [305](#)

EXIT handler
 SQL procedure [2221](#), [2286](#)

exit routine
 named in ALTER TABLE statement [1292](#)
 named in CREATE TABLE statement [1678](#)

EXITPARM column of SYSFIELDS catalog table [2456](#)

EXITPARML column of SYSFIELDS catalog table [2456](#)

EXP function [458](#)

EXPLAIN
 column of SYSPACKAGE catalog table [2519](#)
 statement
 description [1917](#)
 example [1923](#)

EXPLAIN privilege
 GRANT statement [1984](#)
 REVOKE statement [2098](#)

EXPLAIN tables
 DSN_COLDIST_TABLE [2809](#)
 DSN_DETCOST_TABLE [2817](#)
 DSN_FILTER_TABLE [2827](#)
 DSN_FUNCTION_TABLE [2832](#)
 DSN_KEYTGTDIST_TABLE [2837](#)
 DSN_PGRANGE_TABLE [2844](#)
 DSN_PGROUP_TABLE [2848](#)
 DSN_PREDICAT_TABLE [2855](#)
 DSN_PREDICATE_SELECTIVITY [2863](#)
 DSN_PTASK_TABLE [2869](#)
 DSN_QUERY_TABLE [2882](#)
 DSN_QUERYINFO_TABLE
 columns [2874](#)
 DSN_SORT_TABLE [2891](#)
 DSN_SORTKEY_TABLE [2885](#)
 DSN_STATEMENT_CACHE_TABLE [2896](#)
 DSN_STATEMNT_TABLE [2906](#)
 DSN_STRUCT_TABLE [2920](#)
 DSN_VIEWREF_TABLE [2926](#)
 overview [2787](#)
 PLAN_TABLE [2787](#)
 stored procedure [751](#)

EXPLAINABLE column
 SYSPACKSTMT catalog table [2558](#)
 SYSSTMT catalog table [2651](#)

explainable statement
 description [1917](#)
 EXPLAIN statement [1919](#)

EXPLAN column of SYSPLAN catalog table [2575](#)

exposed name [223](#)

EXPREDICATE column of SYSPLAN catalog table [2575](#)

expression
 arithmetic operators [250](#)
 array constructor [279](#)
 array element specification [278](#)
 CASE [264](#)
 CAST specification [267](#)
 concatenation operator [247](#)
 datetime operands [257](#)
 decimal operands [250](#)
 DENSE_RANK expression [280](#)
 DENSERANK expression [280](#)
 distinct type operands [250](#)
 expression (*continued*)
 integer operands [250](#)
 NEXT VALUE expression [292](#)
 nextval-expression [292](#)
 OLAP-specification [280](#)
 precedence of operation [263](#)
 PREVIOUS VALUE expression [292](#)
 prevval-expression [292](#)
 RANK expression [280](#)
 ROW CHANGE TIMESTAMP expression [291](#)
 ROW CHANGE TOKEN expression [291](#)
 ROW_NUMBER expression [280](#)
 row-value [296](#)
 ROWNUMBER expression [280](#)
 subselect statement [1011](#)
 time zone specific [258](#)

expressions [245](#)

EXTENTS column
 SYSINDEXPART catalog table [2474](#)
 SYSINDEXPART_HIST catalog table [2480](#)
 SYSINDEXSPACESTATS catalog table [2482](#)
 SYSTABLEPART catalog table [2665](#)
 SYSTABLEPART_HIST catalog table [2675](#)
 SYSTABLESPACESTATS catalog table [2699](#)

EXTERNAL ACTION clause
 ALTER FUNCTION statement [1106](#), [1122](#), [1147](#)
 CREATE FUNCTION (inlined SQL scalar) statement [1495](#)
 CREATE FUNCTION statement [1436](#), [1464](#), [1482](#)

EXTERNAL clause
 ALTER PROCEDURE (external) statement [1182](#)
 CREATE FUNCTION statement [1461](#), [1480](#)
 CREATE PROCEDURE (external) statement [1589](#)

EXTERNAL NAME clause
 ALTER FUNCTION statement [1102](#)
 ALTER PROCEDURE (SQL - external) statement [1191](#)
 CREATE PROCEDURE (SQL - external) statement [1603](#)

external SQL procedures [35](#)

external stored procedures [35](#)

EXTERNAL_ACTION column of SYSROUTINES catalog table [2621](#)

EXTERNAL_NAME column of SYSROUTINES catalog table [2621](#)

EXTERNAL_SECURITY column
 SYSROUTINES catalog table [2621](#)

external-java-routine-name clause
 ALTER FUNCTION statement [1102](#)
 ALTER PROCEDURE (external) statement [1182](#)
 CREATE FUNCTION statement [1461](#)
 CREATE PROCEDURE (external) statement [1589](#)

external-program
 naming convention [81](#)

external-program-name clause
 CREATE FUNCTION statement [1461](#)

EXTRACT function [459](#)

F

FARINDREF column
 SYSTABLEPART catalog table [2665](#)
 SYSTABLEPART_HIST catalog table [2675](#)

FAROFFPOSF column
 SYSINDEXPART catalog table [2474](#)
 SYSINDEXPART_HIST catalog table [2480](#)

FENCED

FENCED (*continued*)
 clause of CREATE FUNCTION statement [1463](#), [1482](#)
 column of SYSROUTINES catalog table [2621](#)

FENCED clause
 CREATE PROCEDURE (external) statement [1588](#)
 CREATE PROCEDURE (SQL - external) statement [1602](#)

FETCH FIRST clause [1047](#)

FETCH NEXT clause [1047](#)

FETCH statement
 description [1924](#)
 example [1947](#)

fetch-clause [1047](#)

field description [1258](#)

field procedure
 named in ALTER TABLE statement [1258](#)
 named in CREATE TABLE statement [1678](#)

FIELDPROC clause
 ALTER TABLE statement [1258](#)
 CREATE TABLE statement [1678](#)

file reference
 LOB [232](#)

FILESEQNO column of SYSCOPY catalog table [2408](#)

FINAL CALL clause
 ALTER FUNCTION statement [1108](#), [1466](#)
 CREATE FUNCTION statement [1484](#)

FINAL TABLE clause
 FROM clause [1022](#)

FINAL_CALL column of SYSROUTINES catalog table [2621](#)

FIRST clause
 FETCH statement [1929](#)

FIRST ROWSET clause
 FETCH statement [1933](#)

FIRSTKEYCARD column
 SYSINDEXSTATS catalog table [2490](#)

FIRSTKEYCARDF column
 SYSINDEXES catalog table [2461](#)
 SYSINDEXES_HIST catalog table [2472](#)
 SYSINDEXSTATS catalog table [2490](#)
 SYSINDEXSTATS_HIST catalog table [2492](#)

fixed-length binary strings [116](#)

FLDPROC column
 SYSCOLUMNS catalog table [2381](#)
 SYSFIELDS catalog table [2456](#)

FLDTYPE column of SYSFIELDS catalog table [2456](#)

FLOAT
 data type
 CREATE TABLE statement [1663](#)

FLOAT function [451](#)

FLOAT_FORMAT column
 SYSENVIRONMENT catalog table [2452](#)

FLOOR function [462](#)

FOLD column
 SYSENVIRONMENT catalog table [2452](#)

FOR
 clause of CREATE SYNONYM statement [1649](#)
 clause of CREATE TABLE statement [1663](#)
 clause of CREATE TYPE (distinct) statement [1803](#)
 clause of EXPLAIN statement [1919](#)

FOR EACH ROW clause of TRIGGER statement [1749](#)

FOR EACH ROW ON UPDATE AS ROW CHANGE TIMESTAMP clause
 ALTER TABLE statement [1254](#)
 CREATE TABLE statement [1673](#)

FOR EACH STATEMENT clause of TRIGGER statement [1749](#)

FOR FETCH ONLY clause [1072](#)

FOR host-variable or integer constant clause
 FETCH statement [1937](#)

FOR MULTIPLE ROWS clause
 PREPARE statement [2049](#)

FOR n ROWS clause
 EXECUTE statement [1912](#)
 INSERT statement [2004](#)

FOR READ ONLY clause [1072](#)

FOR RESULT SET clause of ALLOCATE CURSOR statement [1093](#)

FOR ROW n OF ROWSET clause
 DELETE statement [1862](#)
 UPDATE statement [2189](#)

FOR SEQUENCE
 clause of CREATE ALIAS statement [1417](#)

FOR SINGLE ROW clause
 PREPARE statement [2049](#)

FOR statement
 example [2229](#)
 SQL procedure [2229](#)

FOR TABLE
 clause of CREATE ALIAS statement [1417](#)

FOR UPDATE clause
 NOFOR precompiler option [326](#)
 select-statement [1071](#)

FOR UPDATE CLAUSE OPTIONAL clause
 ALTER PROCEDURE (SQL - native) statement [1214](#)
 CREATE PROCEDURE (SQL - native) statement [1132](#), [1446](#), [1629](#)
 CREATE TRIGGER statement [1356](#), [1754](#)

FOR UPDATE CLAUSE REQUIRED clause
 ALTER PROCEDURE (SQL - native) statement [1214](#)
 CREATE PROCEDURE (SQL - native) statement [1132](#), [1446](#), [1629](#)
 CREATE TRIGGER statement [1356](#), [1754](#)

FOREIGN KEY clause
 ALTER TABLE statement [1269](#)
 CREATE TABLE statement [1682](#)

foreign keys [10](#)

FOREIGNKEY column of SYSCOLUMNS catalog table [2381](#)

FORMAT column
 SYSTABLEPART catalog table [2665](#)

Fortran application program
 host variable [227](#)
 INCLUDE SQLCA [2308](#)
 varying-length string [104](#)

FREE LOCATOR statement
 description [1949](#)
 example [1949](#)

FREE PAGE column
 SYSINDEXES catalog table [2461](#)

free space
 index [1540](#)
 table space [1331](#)

FREEPAGE
 clause of ALTER INDEX statement
 description [1166](#)
 clause of CREATE INDEX statement
 description [1540](#)
 clause of CREATE TABLESPACE statement
 description [1729](#)
 column of SYSINDEXPART catalog table [2474](#)

FREEPAGE (*continued*)
 column of SYSTABLEPART catalog table [2665](#)
 FREEPAGE clause
 ALTER TABLESPACE statement
 description [1331](#)
 FREEPAGE column
 SYSTABLESPACE catalog table [2688](#)
 FREESPACE column
 SYSLOBSTATS catalog table [2516](#)
 SYSLOBSTATS_HIST catalog table [2516](#)
 FREQUENCYF column
 SYSCOLDIST catalog table [2373](#)
 SYSCOLDIST_HIST catalog table [2377](#)
 SYSCOLDISTSTATS catalog table [2375](#)
 SYSKEYTGTDIST catalog table [2509](#)
 SYSKEYTGTDIST_HIST catalog table [2513](#)
 SYSKEYTGTDISTSTATS catalog table [2511](#)
 FROM clause
 DELETE statement [1857](#)
 PREPARE statement [2050](#)
 REVOKE statement [2071](#)
 subselect [1017](#)
 FROM_TIME column
 SYSINDEXCONTROL catalog table [2460](#)
 FULL OUTER JOIN
 description [1034](#)
 example [1048](#)
 FROM clause of subselect [1034](#)
 FULLKEYCARD column of SYSINDEXSTATS catalog table [2490](#)
 FULLKEYCARDF column
 SYSINDEXES catalog table [2461](#)
 SYSINDEXES_HIST catalog table [2472](#)
 SYSINDEXSTATS catalog table [2490](#)
 SYSINDEXSTATS_HIST catalog table [2492](#)
 fullselect
 CREATE VIEW statement [1815](#)
 description [1060](#)
 example [1064](#)
 INSERT statement [2003](#)
 function
 aggregate
 ARRAY_AGG [354](#)
 AVG [357](#)
 column name [219](#)
 CORR [358](#)
 CORRELATION [358](#)
 COUNT [358](#)
 COUNT_BIG [359](#)
 COVAR [360](#)
 COVAR_POP [360](#)
 COVAR_SAMP [361](#)
 COVARIANCE [360](#)
 COVARIANCE_SAMP [361](#)
 CUME_DIST [362](#)
 description [353](#)
 example [353](#)
 GROUPING [363](#)
 LISTAGG [364](#)
 MAX [367](#)
 MEDIAN [368](#)
 MIN [369](#)
 PERCENT_RANK [372](#)
 PERCENTILE_CONT [370](#)

function (*continued*)
 aggregate (*continued*)
 PERCENTILE_DISC [371](#)
 STDDEV_POP [376](#)
 STDDEV_SAMP [377](#)
 SUM [378](#)
 VAR [379](#)
 VAR_POP [379](#)
 VAR_SAMP or VARIANCE_SAMP [380](#)
 VARIANCE [379](#)
 XMLAGG [381](#)
 built-in [237](#)
 cast function [238](#)
 CHR [415](#)
 column [238](#)
 CORR function [358](#)
 CORRELATION function [358](#)
 CUME_DIST function [280](#)
 DENSE_RANK function [280](#)
 DENSERANK function [280](#)
 description [341](#)
 FIRST_VALUE function [280](#)
 invocation [242](#)
 LAG function [280](#)
 LEAD function [280](#)
 maximum number in select [2247](#)
 name, unqualified [86](#)
 NTH_VALUE function [280](#)
 NTILE function [280](#)
 PERCENT_RANK function [280](#)
 RANK function [280](#)
 RATIO_TO_REPORT function [280](#)
 resolution [239](#)
 row
 description [696](#)
 ROW_NUMBER function [280](#)
 ROWNUMBER function [280](#)
 scalar
 ABS [382](#)
 ACOS [383](#)
 ADD_MONTHS [384](#)
 ARRAY_DELETE [386](#)
 ARRAY_FIRST [387](#)
 ARRAY_LAST [388](#)
 ARRAY_NEXT [389](#)
 ARRAY_PRIOR [391](#)
 ARRAY_TRIM [392](#)
 ASCII [393](#)
 ASCII_CHR [393](#)
 ASCII_STR [394](#)
 ASCIISTR [394](#)
 ASIN [395](#)
 ATAN [395](#)
 ATAN2 [396](#)
 ATANH [395](#)
 BIGINT [396](#)
 BINARY [397](#)
 BITAND [398](#)
 BITANDNOT [398](#)
 BITNOT [398](#)
 BITOR [398](#)
 BITXOR [398](#)
 BLOB [400](#)
 CARDINALITY [402](#)

function (continued)

scalar (continued)

CCSID_ENCODING [403](#)
 CEILING or CEIL [404](#)
 CHAR [405](#)
 CHAR_LENGTH [413](#)
 CHARACTER_LENGTH [413](#)
 CHR [415](#)
 CLOB [415](#)
 COALESCE [417](#)
 COLLATION_KEY [418](#)
 COMPARE_DECFLOAT [421](#)
 CONCAT [422](#)
 COS [425](#)
 COSH [425](#)
 DATE [425](#)
 DAY [426](#)
 DAYOFMONTH [428](#)
 DAYOFWEEK [429](#)
 DAYOFWEEK_ISO [430](#)
 DAYOFYEAR [431](#)
 DAYS [432](#)
 DBCLOB [434](#)
 DECFLOAT [437](#)
 DECFLOAT_FORMAT [438](#)
 DECFLOAT_SORTKEY [440](#)
 DECIMAL or DEC [441](#)
 DECODE [443](#)
 DECRYPT_BINARY [444](#)
 DECRYPT_BIT [444](#)
 DECRYPT_CHAR [444](#)
 DECRYPT_DATAKEY_BIGINT [446](#)
 DECRYPT_DATAKEY_BIT [446](#)
 DECRYPT_DATAKEY_CLOB [446](#)
 DECRYPT_DATAKEY_DBCLOB [446](#)
 DECRYPT_DATAKEY_DECIMAL [446](#)
 DECRYPT_DATAKEY_INTEGER [446](#)
 DECRYPT_DATAKEY_VARCHAR [446](#)
 DECRYPT_DATAKEY_VARGRAPHIC [446](#)
 DEGREES [449](#)
 DIFFERENCE [450](#)
 DIGITS [450](#)
 DOUBLE or DOUBLE_PRECISION [451](#)
 DSN_XMLVALIDATE [452](#)
 EBCDIC_CHR [453](#)
 EBCDIC_STR [453](#)
 ENCRYPT_DATAKEY [454](#)
 ENCRYPT_TDES [456](#)
 EXP [458](#)
 EXTRACT [459](#)
 FLOOR [462](#)
 GENERATE_UNIQUE [462](#)
 GENERATE_UNIQUE_BINARY [462](#)
 GETHINT [463](#)
 GETVARIABLE [464](#)
 GRAPHIC [465](#)
 GREATEST [470](#)
 HASH [471](#)
 HASH_MD5 [472](#)
 HASH_SHA1 [472](#)
 HASH_SHA256 [472](#)
 HEX [474](#)
 HOUR [475](#)
 IDENTITY_VAL_LOCAL [476](#)

function (continued)

scalar (continued)

IFNULL [479](#)
 INSERT [480](#)
 INSTR [482](#)
 JULIAN_DAY [484](#)
 LAST_DAY [485](#)
 LCASE [495](#)
 LCASE function [486](#)
 LEAST [486](#)
 LEFT [487](#), [576](#)
 LENGTH [489](#)
 LN [490](#)
 LOCATE [490](#)
 LOCATE_IN_STRING [493](#)
 LOG [490](#)
 LOG10 [494](#)
 LOWER [495](#)
 LPAD [498](#)
 LTRIM [500](#)
 MAX [501](#)
 MAX_CARDINALITY [502](#)
 MICROSECOND [503](#)
 MIDNIGHT_SECONDS [504](#)
 MIN [505](#)
 MINUTE [505](#)
 MOD [506](#)
 MONTH [508](#)
 MONTHS_BETWEEN [508](#)
 MULTIPLY_ALT [517](#)
 NEXT_DAY [518](#)
 NORMALIZE_DECFLOAT [520](#)
 NORMALIZE_STRING [521](#)
 NULLIF [522](#)
 NVL [523](#)
 OVERLAY [523](#)
 PACK [526](#)
 POSITION [529](#)
 POSSTR [532](#)
 POWER [533](#)
 QUANTIZE [534](#)
 QUARTER [535](#)
 RADIANS [536](#)
 RAISE_ERROR [536](#)
 RAND [537](#)
 RANDOM [537](#)
 REAL [538](#)
 REGEXP_COUNT [539](#)
 REGEXP_INSTR [541](#)
 REGEXP_LIKE [543](#)
 REGEXP_REPLACE [546](#)
 REGEXP_SUBSTR [549](#)
 REPEAT [551](#)
 REPLACE [552](#)
 RID [555](#)
 RIGHT [556](#)
 ROUND [558](#)
 ROUND_TIMESTAMP [559](#)
 ROWID [563](#)
 RPAD [563](#)
 RTRIM [565](#)
 SECOND [568](#)
 SIGN [570](#)
 SIN [570](#)

function (*continued*)

scalar (*continued*)

SINH [571](#)
SMALLINT [571](#)
SOAPHTTPC and SOAPHTTPV [573](#)
SOAPHTTPNC and SOAPHTTPNV [574](#)
SOUNDEX [572](#)
SPACE [575](#)
SQRT [575](#)
STRIP [576](#)
STRLEFT [556](#), [576](#)
STRPOS [577](#)
STRRIGHT [577](#)
SUBSTR [577](#)
SUBSTRING [579](#)
TAN [583](#)
TANH [583](#)
TIME [584](#)
TIMESTAMP [584](#)
TIMESTAMP_FORMAT [591](#)
TIMESTAMP_ISO [595](#)
TIMESTAMP_TZ [596](#)
TIMESTAMPADD [587](#)
TIMESTAMPDIFF [588](#)
TO_CHAR [598](#), [623](#)
TO_CLOB [598](#)
TO_DATE [591](#), [599](#)
TO_NUMBER [599](#)
TO_TIMESTAMP [591](#), [600](#)
TOTALORDER [599](#)
TRANSLATE [600](#)
TRIM [603](#)
TRIM_ARRAY [605](#)
TRUNC_TIMESTAMP [607](#)
TRUNCATE [606](#)
UCASE [610](#), [612](#)
UNICODE [610](#)
UNICODE_STR [611](#)
UNISTR [611](#)
UNPACK [696](#)
UPPER [612](#)
VALUE [417](#)
VARBINARY [614](#)
VARCHAR [615](#)
VARCHAR_BIT_FORMAT [622](#)
VARCHAR_FORMAT [623](#)
VARGRAPHIC [632](#)
VERIFY_GROUP_FOR_USER [637](#)
VERIFY_ROLE_FOR_USER [638](#)
VERIFY_TRUSTED_CONTEXT_ROLE_F
OR_USER [640](#)
WEEK [641](#)
WEEK_ISO [642](#)
XMLATTRIBUTES [644](#)
XMLCOMMENT [645](#)
XMLCONCAT [645](#)
XMLDOCUMENT [646](#)
XMLELEMENT [647](#)
XMLFOREST [651](#)
XMLMODIFY [653](#)
XMLNAMESPACES [656](#)
XMLPARSE [657](#)
XMLPI [659](#)
XMLQUERY [659](#)

function (*continued*)

scalar (*continued*)

XMLSERIALIZE [662](#)
XMLTEXT [665](#)
XMLXSROBJECTID [666](#)
XSLTRANSFORM [667](#)
YEAR [668](#)

string units [106](#)

table

ADMIN_TASK_LIST function [669](#)
ADMIN_TASK_OUTPUT function [673](#)
ADMIN_TASK_STATUS function [675](#)
BLOCKING_THREADS function [678](#)
description [669](#)
MQREAD function [510](#)
MQREADALL function [685](#)
MQREADALLCLOB function [687](#)
MQREADCLOB function [511](#)
MQRECEIVE function [512](#)
MQRECEIVEALL function [689](#)
MQRECEIVEALLCLOB function [691](#)
MQRECEIVECLOB function [514](#)
MQSEND function [516](#)

types [237](#)

unqualified name [86](#)

version resolution [243](#)

FUNCTION clause

COMMENT statement [1401](#)

DROP statement [1892](#)

function resolution

built-in function [243](#)

data type cast [242](#)

data type promotion [241](#)

implicit casting [242](#)

promotable process [241](#)

function table [1917](#)

FUNCTION_LVL

column of SYSDYNQRY catalog table [2444](#)

FUNCTION_LVL column

SYSPACKAGE catalog table [2519](#)

FUNCTION_TYPE column

SYSROUTINES catalog table [2621](#)

function, built-in

nesting [382](#)

scalar

description [382](#)

example [382](#)

functions

best fit [241](#)

casting

XMLCAST [277](#)

column

REGR_AVGX [374](#)

REGR_AVGY [374](#)

REGR_COUNT [374](#)

REGR_ICPT [374](#)

REGR_INTERCEPT [374](#)

REGR_R2 [374](#)

REGR_SLOPE [374](#)

REGR_SXX [374](#)

REGR_SXY [374](#)

REGR_SYY [374](#)

regression [374](#)

CONTAINS [422](#)

functions (*continued*)

introduction [35](#)

list [341](#)

scalar

ADD_DAYS [383](#)

BTRIM [401](#)

DAYS_BETWEEN [433](#)

NEXT_MONTH [520](#)

SCORE [566](#)

table

XMLTABLE [693](#)

VALUE [614](#)

FUNCTIONS column

SYSPACKAGE catalog table [2519](#)

SYSPLAN catalog table [2575](#)

G

GBPCACHE clause

ALTER INDEX statement [1166](#)

ALTER TABLESPACE statement [1334](#)

CREATE INDEX statement [1541](#)

CREATE LOB TABLESPACE statement [1557](#)

CREATE TABLESPACE statement [1730](#)

GBPCACHE column

SYSINDEXES catalog table [2461](#)

SYSINDEXPART catalog table [2474](#)

SYSTABLEPART catalog table [2665](#)

SYSTABLESPACE catalog table [2688](#)

GEN_SESSION_USER column

SYSROLES catalog table [2618](#), [2722](#)

general-use programming information, described [2970](#)

GENERATE KEY USING clause

CREATE INDEX statement [1534](#)

GENERATE_UNIQUE function [462](#)

GENERATE_UNIQUE_BINARY function [462](#)

GENERATED clause

ALTER TABLE statement [1250](#)

CREATE TABLE statement [1672](#)

DECLARE GLOBAL TEMPORARY TABLE statement [1836](#)

GENERIC column of LUNAMES catalog table [2354](#)

GET DIAGNOSTICS statement

description [1949](#)

SQL procedure [2230](#), [2290](#)

GET_ARCHIVE

built-in global variable [330](#)

GET_CONFIG stored procedure [923](#)

GET_LINE procedure [919](#), [923](#)

GET_LINES procedure [920](#)

GET_MESSAGE stored procedure [942](#)

GET_SYSTEM_INFO stored procedure [949](#)

GETHINT function [463](#)

GETVARIABLE function [464](#)

global variable

built-in [329](#)–[334](#)

CATALOG_LEVEL [329](#)

CLIENT_IPADDR [330](#)

DEFAULT_SQLLEVEL [330](#)

dropping [1899](#)

GET_ARCHIVE [330](#)

MAX_LOCKS_PER_TABLESPACE [331](#)

MAX_LOCKS_PER_USER [331](#)

MOVE_TO_ARCHIVE [332](#)

naming convention [81](#)

global variable (*continued*)

PRODUCTID_EXT [332](#)

REPLICATION_OVERRIDE [333](#)

TEMPORAL_LOGICAL_TRANSACTION_TIME [334](#)

TEMPORAL_LOGICAL_TRANSACTIONS [334](#)

global variable, built-in [329](#)

global variables

privileges

granting [1992](#)

revoking [2106](#)

GO TO clause of WHENEVER statement [2204](#)

GOTO statement

example [2290](#)

examples [2231](#)

SQL procedure [2231](#), [2290](#)

GRAMMAR column

SYSIBM.XSROBJECTGRAMMAR table [2784](#)

SYSIBM.XSROBJECTS table [2782](#)

GRANT statement

collection privileges [1967](#)

database privileges [1968](#)

description [1963](#)

function privileges [1970](#)

package privileges [1975](#)

plan privileges [1977](#)

procedure privileges [1970](#)

schema privileges [1978](#)

sequence privileges [1979](#)

system privileges [1981](#)

table privileges [1988](#)

USAGE privilege [1991](#)

use privileges [1993](#)

variable privileges [1992](#)

view privileges [1988](#)

GRANTEDTS

column of SYSSEQUENCEAUTH catalog table [2640](#)

GRANTEDTS column

SYSCOLAUTH catalog table [2371](#)

SYSDBAUTH catalog table [2432](#)

SYSPLANAUTH catalog table [2582](#)

SYSRESAUTH catalog table [2615](#)

SYSROUTINEAUTH catalog table [2619](#)

SYSSCHEMAAUTH catalog table [2638](#)

SYSTABAUTH catalog table [2659](#)

SYSUSERAUTH catalog table [2715](#)

SYSVARIABLEAUTH catalog table [2722](#)

GRANTEE

column of SYSSEQUENCEAUTH catalog table [2640](#)

GRANTEE column

SYSCOLAUTH catalog table [2371](#)

SYSDBAUTH catalog table [2432](#)

SYSPACKAUTH catalog table [2536](#)

SYSPLANAUTH catalog table [2582](#)

SYSRESAUTH catalog table [2615](#)

SYSROUTINEAUTH catalog table [2619](#)

SYSSCHEMAAUTH catalog table [2638](#)

SYSTABAUTH catalog table [2659](#)

SYSUSERAUTH catalog table [2715](#)

SYSVARIABLEAUTH catalog table [2722](#)

GRANTEETYPE

column of SYSSEQUENCEAUTH catalog table [2640](#)

GRANTEETYPE column

SYSCOLAUTH catalog table [2371](#)

SYSDBAUTH catalog table [2432](#)

GRANTEETYPE column (*continued*)

- SYPACKAUTH catalog table [2536](#)
- SYSPLANAUTH catalog table [2582](#)
- SYSRESAUTH catalog table [2615](#)
- SYSROUTINEAUTH catalog table [2619](#)
- SYSSCHEMAAUTH catalog table [2638](#)
- SYSTABAUTH catalog table [2659](#)
- SYSUSERAUTH catalog table [2715](#)
- SYSVARIABLEAUTH catalog table [2722](#)

GRANTOR column

- SYSCOLAUTH catalog table [2371](#)
- SYSDBAUTH catalog table [2432](#)
- SYPACKAUTH catalog table [2536](#)
- SYSPLANAUTH catalog table [2582](#)
- SYSRESAUTH catalog table [2615](#)
- SYSROUTINEAUTH catalog table [2619](#)
- SYSSCHEMAAUTH catalog table [2638](#)
- SYSTABAUTH catalog table [2659](#)
- SYSUSERAUTH catalog table [2715](#)
- SYSVARIABLEAUTH catalog table [2722](#)

GRANTORS

- column of SYSSEQUENCEAUTH catalog table [2640](#)

GRANTORTYPE column

- SYSCOLAUTH catalog table [2371](#)
- SYSDBAUTH catalog table [2432](#)
- SYPACKAUTH catalog table [2536](#)
- SYSPLANAUTH catalog table [2582](#)
- SYSRESAUTH catalog table [2615](#)
- SYSROUTINEAUTH catalog table [2619](#)
- SYSSCHEMAAUTH catalog table [2638](#)
- SYSSEQUENCEAUTH catalog table [2640](#)
- SYSTABAUTH catalog table [2659](#)
- SYSUSERAUTH catalog table [2715](#)
- SYSVARIABLEAUTH catalog table [2722](#)

GRANULARITY column of SYSTRIGGERS catalog table [2712](#)

GRAPHIC

data type

- CREATE TABLE statement [1663](#)
- description [112](#)

function [465](#)

option of precompiler [325](#)

GRAPHIC data type [17](#)

graphic string

- constants [173](#)
- description [112](#)
- operands [168](#)

graphic strings [17](#)

GREATEST function [470](#), [501](#)

group buffer pools

- described [41](#)

GROUP BY clause

- cannot join view [1817](#)
- subselect
 - description [1037](#)
 - results [1010](#)

GROUP_MEMBER column

- SYSCOPY catalog table [2408](#)
- SYSDATABASE catalog table [2427](#)
- SYSPACKAGE catalog table [2519](#)
- SYSPLAN catalog table [2575](#)

grouping column [1037](#)

GROUPING function [363](#)

GROUPING SETS clause

- examples [1054](#)

H

handler

- SQL procedure [2221](#), [2286](#)

handling errors

- SQL procedure [2221](#), [2286](#)

hash access [53](#)

HASH column

- SYSINDEXES catalog table [2461](#)

HASH function [471](#)

hash spaces [53](#)

HASH_CRC32 function [472](#)

HASH_MD5 function [472](#)

HASH_SHA1 function [472](#)

HASH_SHA256 function [472](#)

HASHDATAPAGES column

- SYSTABLESPACE catalog table [2688](#)

HASHSPACE column

- SYSTABLESPACE catalog table [2688](#)

HAVING clause of subselect

- description [1043](#)
- results [1010](#)

HDFS_READ function [2947](#)

held connection state [70](#)

HEX function [474](#)

HIDDEN column of SYSCOLUMNS catalog table [2381](#)

high encryption [1791](#)

HIGH2KEY column

- SYSCOLSTATS catalog table [2379](#)
- SYSCOLUMNS catalog table [2381](#)
- SYSCOLUMNS_HIST catalog table [2395](#)
- SYSKEYTARGETS catalog table [2500](#)
- SYSKEYTARGETS_HIST catalog table [2505](#)
- SYSKEYTARGETSTATS catalog table [2503](#)

HIGHDSNUM column of SYSCOPY catalog table [2408](#)

HIGHKEY column

- SYSKEYTARGETSTATS catalog table [2503](#)

HIGHKEY column of SYSCOLSTATS catalog table [2379](#)

HIGHVALUE column

- SYSCOLDIST catalog table [2373](#)
- SYSCOLDIST_HIST catalog table [2377](#)
- SYSCOLDISTSTATS catalog table [2375](#)
- SYSKEYTGTDIST catalog table [2509](#)
- SYSKEYTGTDIST_HIST catalog table [2513](#)
- SYSKEYTGTDISTSTATS catalog table [2511](#)

history tables

- Db2 catalog [2742](#)

HOLD LOCATOR statement

- description [1994](#)
- example [1995](#)

host identifier [77](#)

host label

- naming convention [81](#)

host structure

- description [235](#)

host variable

- colon [227](#)
- description [227](#)
- EXECUTE IMMEDIATE statement [1915](#)
- EXPLAIN statement [1919](#)
- input [227](#)
- naming convention [82](#)
- output [227](#)
- SELECT INTO statement [2119](#)

HOST_LANGUAGE column
 SYSENVIRONMENT catalog table [2452](#)
 host-variable-arrays
 description [236](#)
 HOSTLANG column
 SYSDBRM catalog table [2437](#)
 SYSPACKAGE catalog table [2519](#)
 HOUR function [475](#)
 HPJCOMPILE_OPTS column
 SYSJAVAOPTS catalog table [2496](#)
 HTTPBLOB function [2948](#)
 HTTPCLOB function [2949](#)
 HTTPDELETEBLOB function [2950](#)
 HTTPDELETECLOB function [2950](#)
 HTTPGETBLOB function [2952](#)
 HTTPGETBLOBFILE function [2954](#)
 HTTPGETCLOB function [2952](#)
 HTTPGETCLOBFILE function [2954](#)
 HTTPHEAD function [2955](#)
 HTTPPOSTBLOB function [2956](#)
 HTTPPOSTCLOB function [2956](#)
 HTTPPUTBLOB function [2957](#)
 HTTPPUTCLOB function [2957](#)
 HTYPE column
 SYSIBM.XSROBJECTHIERARCHIES table [2784](#)

I

I/O processing
 CURRENT DEGREE special register [194](#)
 CURRENT EXPLAIN MODE special register [194](#)
 IBM MQ functions [341](#)
 IBMREQD
 column of SYSSEQUENCEAUTH catalog table [2640](#)
 IBMREQD column
 IPLIST catalog table [2348](#)
 IPNAMES catalog table [2349](#)
 LOCATIONS catalog table [2351](#)
 LULIST catalog table [2353](#)
 LUMODES catalog table [2353](#)
 LUNAMES catalog table [2354](#)
 MODESELECT catalog table [2358](#)
 release dependency indicators [2333](#)
 SYSAUXRELS catalog table [2368](#)
 SYSCHECKDEP catalog table [2369](#)
 SYSCHECKS catalog table [2369](#)
 SYSCHECKS2 catalog table [2370](#)
 SYSCOLDIST catalog table [2373](#)
 SYSCOLDIST_HIST catalog table [2377](#)
 SYSCOLDISTSTATS catalog table [2375](#)
 SYSCOLSTATS catalog table [2379](#)
 SYSCOLUMNS catalog table [2381](#)
 SYSCOLUMNS_HIST catalog table [2395](#)
 SYSCONSTDEP catalog table [2400](#)
 SYSCONTEXT catalog table [2401](#)
 SYSCONTEXTAUTHIDS catalog table [2404](#)
 SYSCOPY catalog table [2408](#)
 SYSTXTTRUSTATTRS catalog table [2426](#)
 SYSDATABASE catalog table [2427](#)
 SYSDATATYPES catalog table [2429](#)
 SYSDBAUTH catalog table [2432](#)
 SYSDBRM catalog table [2437](#)
 SYSDependencies catalog table [2439](#)
 SYSDUMMY1 catalog table [2443](#)

IBMREQD column (*continued*)
 SYSDUMMYA catalog table [2443](#)
 SYSDUMMYE catalog table [2444](#)
 SYSDUMMYU catalog table [2444](#)
 SYSENVIRONMENT catalog table [2452](#)
 SYSFIELDS catalog table [2456](#)
 SYSFOREIGNKEYS catalog table [2458](#)
 SYSINDEXES catalog table [2461](#)
 SYSINDEXES_HIST catalog table [2472](#)
 SYSINDEXPART catalog table [2474](#)
 SYSINDEXPART_HIST catalog table [2480](#)
 SYSINDEXSPACESTATS catalog table [2482](#)
 SYSINDEXSTATS catalog table [2490](#)
 SYSINDEXSTATS_HIST catalog table [2492](#)
 SYSJARCONTENTS catalog table [2494](#)
 SYSJAROBJECTS catalog table [2495](#)
 SYSJAVAOPTS catalog table [2496](#)
 SYSJAVAPATHS catalog table [2497](#)
 SYSKEYCOLUSE catalog table [2497](#)
 SYSKEYS catalog table [2498](#)
 SYSKEYTARGETS catalog table [2500](#)
 SYSKEYTARGETS_HIST catalog table [2505](#)
 SYSKEYTARGETSTATS catalog table [2503](#)
 SYSKEYTGTDIST catalog table [2509](#)
 SYSKEYTGTDIST_HIST catalog table [2513](#)
 SYSKEYTGTDISTSTATS catalog table [2511](#)
 SYSLOBSTATS catalog table [2516](#)
 SYSLOBSTATS_HIST catalog table [2516](#)
 SYSOBJROLEDEP catalog table [2517](#)
 SYSPACKAGE catalog table [2519](#)
 SYSPACKAUTH catalog table [2536](#)
 SYSPACKDEP catalog table [2554](#)
 SYSPACKLIST catalog table [2558](#)
 SYSPACKSTMT catalog table [2558](#)
 SYSPARMS catalog table [2565](#)
 SYSPKSYSTEM catalog table [2574](#)
 SYSPLAN catalog table [2575](#)
 SYSPLANAUTH catalog table [2582](#)
 SYSPLANDEP catalog table [2584](#)
 SYSPLSYSTEM catalog table [2586](#)
 SYSRELS catalog table [2613](#)
 SYSRESAUTH catalog table [2615](#)
 SYSROLES catalog table [2618](#)
 SYSROUTINEAUTH catalog table [2619](#)
 SYSROUTINES catalog table [2621](#)
 SYSROUTINES_OPTS catalog table [2635](#)
 SYSROUTINES_SRC catalog table [2637](#)
 SYSSCHEMAAUTH catalog table [2638](#)
 SYSSEQUENCEDEP catalog table [2646](#)
 SYSSEQUENCES catalog table [2643](#)
 SYSSTMT catalog table [2651](#)
 SYSSTOGROUP catalog table [2655](#)
 SYSSTRINGS catalog table [2656](#)
 SYSSYNONYMS catalog table [2658](#)
 SYSTABAUTH catalog table [2659](#)
 SYSTABCONST catalog table [2664](#)
 SYSTABLEPART catalog table [2665](#)
 SYSTABLEPART_HIST catalog table [2675](#)
 SYSTABLES catalog table [2678](#)
 SYSTABLES_HIST catalog table [2707](#)
 SYSTABLESPACE catalog table [2688](#)
 SYSTABLESPACESTATS catalog table [2699](#)
 SYSTABSTATS catalog table [2710](#)
 SYSTABSTATS_HIST catalog table [2711](#)

IBMREQD column (*continued*)
 SYSTRIGGERS catalog table [2712](#)
 SYSUSERAUTH catalog table [2715](#)
 SYSVARIABLEAUTH catalog table [2722](#)
 SYSVARIABLES catalog table [2724](#)
 SYSVIEWDEP catalog table [2729](#)
 SYSVIEWS catalog table [2730](#)
 SYSVOLUMES catalog table [2733](#)
 SYSXMLRELS catalog table [2734](#)
 SYSXMLSTRINGS catalog table [2735](#)
 USERNAMES catalog table [2737](#)
 IBMREQD column of SYSCOLAUTH catalog table [2371](#)
 ICBACKUP column of SYSCOPY catalog table [2408](#)
 ICTYPE column of SYSCOPY catalog table [2408](#)
 ICUNIT column of SYSCOPY catalog table [2408](#)
 identifier in SQL
 delimited [77](#)
 ordinary [77](#)
 identifiers
 SQL [77](#)
 identity column
 ALTER TABLE statement [1251](#)
 CREATE TABLE statement [1676](#)
 identity columns [19](#)
 IDENTITY_VAL_LOCAL function [476](#)
 IF statement
 example [2232](#), [2292](#)
 SQL procedure [2232](#), [2292](#)
 IFNULL function [479](#)
 IGNORE DELETE TRIGGERS clause
 TRUNCATE statement [2177](#)
 IMAGCOPY privilege
 GRANT statement [1969](#)
 REVOKE statement [2079](#)
 IMAGCOPYAUTH column of SYSDBAUTH catalog table [2432](#)
 IMMEDIATE clause
 TRUNCATE statement [2177](#)
 IMMEDIATE column
 SYSPACKAGE catalog table [2519](#)
 SYSPLAN catalog table [2575](#)
 IMPLICIT column
 SYSDATABASE catalog table [2427](#)
 SYSINDEXES catalog table [2461](#)
 SYSTABLESPACE catalog table [2688](#)
 implicit time zone [124](#)
 IMPLICITLY HIDDEN clause
 ALTER TABLE statement [1257](#)
 CREATE TABLE statement [1679](#)
 IN
 clause of CREATE AUXILIARY TABLE statement [1419](#)
 clause of CREATE LOB TABLESPACE statement [1556](#)
 clause of CREATE TABLE statement [1693](#), [1694](#)
 clause of CREATE TABLESPACE statement [1724](#)
 predicate [166](#), [306](#)
 IN clause
 ALTER PROCEDURE (SQL - native) statement [1202](#)
 CREATE PROCEDURE (external) statement [1586](#)
 CREATE PROCEDURE (SQL - external) statement [1601](#)
 CREATE PROCEDURE (SQL - native) statement [1616](#)
 IN EXCLUSIVE MODE clause of LOCK TABLE statement [2017](#)
 IN list [306](#)
 IN SHARE MODE clause of LOCK TABLE statement [2017](#)
 INCCSID column of SYSSTRINGS catalog table [2656](#)
 INCLUDE clause
 DELETE statement [1860](#)
 INSERT statement [2001](#)
 MERGE statement [2025](#)
 UPDATE statement [2187](#)
 INCLUDE statement
 assembler declarations [2308](#)
 description [1995](#)
 example [1996](#)
 SQLCA
 C [2308](#)
 COBOL [2308](#)
 Fortran [2308](#)
 SQLDA
 assembler [2326](#)
 C [2326](#)
 C++ [2326](#)
 COBOL [2326](#)
 PL/I [2308](#), [2326](#)
 INCLUDING COLUMN DEFAULTS clause
 CREATE TABLE statement [1689](#)
 DECLARE GLOBAL TEMPORARY TABLE statement [1838](#)
 INCLUDING DEPENDENT PRIVILEGES clause of REVOKE statement [2072](#), [2077](#), [2079](#), [2085](#), [2088](#), [2089](#), [2092](#), [2093](#), [2099](#), [2102](#), [2104](#), [2107](#), [2109](#)
 INCLUDING IDENTITY COLUMN ATTRIBUTES clause
 CREATE TABLE statement [1688](#)
 DECLARE GLOBAL TEMPORARY TABLE statement [1837](#)
 INCLUDING ROW CHANGE TIMESTAMP COLUMN ATTRIBUTES clause
 CREATE TABLE statement [1688](#)
 INCLUSIVE clause
 ALTER INDEX statement [1171](#)
 ALTER TABLE statement [1276](#), [1279](#), [1280](#), [1282](#)
 CREATE INDEX statement [1544](#)
 CREATE TABLE statement [1696](#)
 INCREMENT BY
 clause of ALTER SEQUENCE statement [1225](#)
 INCREMENT BY clause
 CREATE SEQUENCE statement [1640](#)
 INCREMENT column of SYSSEQUENCES catalog table [2643](#)
 incrementing time [261](#)
 index
 accelerators table [2931](#)
 altering
 ALTER INDEX statement [1157](#)
 creating with CREATE INDEX statement [1524](#)
 directory table [2770](#)
 dropping [1894](#)
 name, unqualified [86](#)
 naming convention [82](#)
 partitioning [1543](#)
 program authorization table [2939](#)
 renaming with RENAME statement [2066](#)
 types
 changing [1157](#)
 unqualified name [86](#)
 XML schema repository table [2779](#)
 INDEX clause
 ALTER INDEX statement [1157](#)
 COMMENT statement [1403](#)
 CREATE INDEX statement [1530](#)
 DROP statement [1894](#)
 INDEX privilege

INDEX privilege (*continued*)
 GRANT statement [1989](#)
 REVOKE statement [2102](#)
 index spaces [51](#)
 INDEXAUTH column of SYSTABAUTH catalog table [2659](#)
 INDEXBP
 clause of CREATE DATABASE statement [1422](#)
 column of SYSDATABASE catalog table [2427](#)
 INDEXBP clause
 ALTER DATABASE statement [1095](#)
 indexes [29](#)
 INDEXSPACE column
 SYSINDEXES catalog table [2461](#)
 SYSINDEXSPACESTATS catalog table [2482](#)
 INDEXSTATUS column
 SYSINDEXES catalog table [2461](#)
 INDEXTYPE column
 SYSINDEXES catalog table [2461](#)
 indicator array [235](#)
 indicator variable
 description [227](#)
 string expression [1915](#)
 infix operators [250](#)
 INHERIT SPECIAL REGISTERS clause
 ALTER FUNCTION statement [1111](#)
 ALTER PROCEDURE (external) statement [1188](#)
 ALTER PROCEDURE (SQL - external) statement [1193](#)
 ALTER PROCEDURE (SQL - native) statement [1205](#)
 CREATE FUNCTION statement [1469](#), [1487](#)
 CREATE PROCEDURE (external) statement [1595](#)
 CREATE PROCEDURE (SQL - external) statement [1605](#)
 CREATE PROCEDURE (SQL - native) statement [1125](#),
 [1439](#), [1620](#)
 INITIAL_INSTS column of SYSROUTINES catalog table [2621](#)
 INITIAL_IOS column of SYSROUTINES catalog table [2621](#)
 INLINE LENGTH clause
 CREATE TABLE statement [1258](#), [1679](#)
 INLINE_LENGTH column
 SYSDATATYPES catalog table [2429](#)
 inlined SQL scalar statements
 ALTER FUNCTION [1142](#)
 INNER JOIN
 description [1034](#)
 example [1048](#)
 FROM clause of subselect [1034](#)
 INOUT clause
 ALTER PROCEDURE (SQL - native) statement [1202](#)
 CREATE PROCEDURE (external) statement [1586](#)
 CREATE PROCEDURE (SQL - external) statement [1601](#)
 CREATE PROCEDURE (SQL - native) statement [1616](#)
 input host variable [227](#)
 INPUT SEQUENCE clause
 ORDER BY clause of subselect [1044](#)
 INSENSITIVE clause
 DECLARE CURSOR statement [1821](#)
 FETCH statement [1927](#), [1928](#)
 INSERT clause of CREATE TRIGGER statement [1348](#), [1756](#),
[1776](#)
 INSERT function [480](#)
 INSERT privilege
 GRANT statement [1989](#)
 REVOKE statement [2102](#)
 insert rule [2005](#)
 INSERT statement
 INSERT statement (*continued*)
 check constraints [27](#)
 description [1996](#)
 example [2011](#)
 INSERTALG column
 SYSTABLESPACE catalog table [2688](#)
 INSERTAUTH column of SYSTABAUTH catalog table [2659](#)
 inserting
 declaration in a program [1995](#)
 rows in a table [1996](#), [2019](#)
 INSTANCE column
 SYSINDEXSPACESTATS catalog table [2482](#)
 SYSTABLESPACE catalog table [2688](#)
 SYSTABLESPACESTATS catalog table [2699](#)
 INSTR function [482](#)
 INSTS_PER_INVOC column of SYSROUTINES catalog table
[2621](#)
 INT function [483](#)
 INTEGER
 data type
 CREATE TABLE statement [1663](#)
 INTEGER data type [19](#)
 INTEGER or INT [483](#)
 integrated catalog facility
 CREATE INDEX statement [1540](#)
 integrated catalog facility (ICF)
 identifier [80](#)
 interactive SQL [2](#), [1090](#)
 INTERSECT clause [1061](#)
 INTO clause
 DESCRIBE CURSOR statement [1870](#)
 DESCRIBE INPUT statement [1871](#)
 DESCRIBE PROCEDURE statement [1879](#)
 DESCRIBE statement [1873](#), [1882](#)
 FETCH statement [1936](#)
 INSERT statement [2000](#)
 MERGE statement [2024](#)
 PREPARE statement [2044](#)
 SELECT INTO statement [2119](#)
 VALUES INTO statement [2201](#)
 INTO DESCRIPTOR clause
 FETCH statement [1937](#), [1938](#)
 INTO host-variable-array
 clause
 FETCH statement [1938](#)
 invoke behavior for dynamic SQL statements [94](#)
 IOS_PER_INVOC column of SYSROUTINES catalog table
[2621](#)
 IPADDR column
 IPLIST catalog table [2348](#)
 IPADDR column of IPNAMES catalog table [2349](#)
 IPREFIX column
 SYSINDEXPART catalog table [2474](#)
 SYSTABLEPART catalog table [2665](#)
 IS clause
 COMMENT statement [1404](#)
 LABEL statement [2016](#)
 IS DISTINCT FROM predicate [304](#)
 IS NULL predicate [24](#)
 ISOBID column
 SYSINDEXES catalog table [2461](#)
 ISOLATION
 column of SYSPACKAGE catalog table [2519](#)
 column of SYSPACKSTMT catalog table [2558](#)

ISOLATION (continued)

column of SYSPLAN catalog table [2575](#)
column of SYSSTMT catalog table [2651](#)

ISOLATION column

SYSVIEWS catalog table [2730](#)

isolation level

control by SQL statement
DELETE statement [1863](#)
INSERT statement [2003](#)
select-statement [1073](#)
UPDATE statement [2190](#)

ISOLATION LEVEL clause

ALTER PROCEDURE (SQL - native) statement [1208](#)
CREATE PROCEDURE (SQL - native) statement [1128](#),
[1442](#), [1623](#)
CREATE TRIGGER statement [1354](#), [1752](#)

isolation-clause

DELETE statement [1863](#)
INSERT statement [2003](#)
UPDATE statement [2190](#)

ITERATE statement

example [2293](#)
examples [2233](#)
SQL procedure [2233](#), [2293](#)

IX_EXTENSION_TYPE column

SYSINDEXES catalog table [2461](#)

IXCREATOR column

SYSINDEXPART catalog table [2474](#)
SYSINDEXPART_HIST catalog table [2480](#)
SYSKEYS catalog table [2498](#)
SYSTABLEPART catalog table [2665](#)

IXCREATORc column

SYSINDEXCONTROL catalog table [2460](#)

IXNAME column

SYSINDEXCONTROL catalog table [2460](#)
SYSINDEXPART catalog table [2474](#)
SYSINDEXPART_HIST catalog table [2480](#)
SYSKEYS catalog table [2498](#)
SYSKEYTARGETS catalog table [2500](#)
SYSKEYTARGETS_HIST catalog table [2505](#)
SYSKEYTARGETSTATS catalog table [2503](#)
SYSKEYTGTDIST catalog table [2509](#)
SYSKEYTGTDIST_HIST catalog table [2513](#)
SYSKEYTGTDISTSTATS catalog table [2511](#)
SYSTABCONST catalog table [2664](#)
SYSTABLEPART catalog table [2665](#)

IXNAME column of SYSRELS catalog table [2613](#)

IXOWNER column

SYSRELS catalog table [2613](#)
SYSTABCONST catalog table [2664](#)

IXSCHEMA column

SYSKEYTARGETS catalog table [2500](#)
SYSKEYTARGETS_HIST catalog table [2505](#)
SYSKEYTARGETSTATS catalog table [2503](#)
SYSKEYTGTDIST catalog table [2509](#)
SYSKEYTGTDIST_HIST catalog table [2513](#)
SYSKEYTGTDISTSTATS catalog table [2511](#)

J

JAQL_SUBMIT function [2958](#)

JAR file

unqualified name [86](#)

JAR file privileges

JAR file privileges (continued)

granting [1991](#)
revoking [2104](#)

JAR_DATA column

SYSJARDATA catalog table [2495](#)
SYSJAROBJECTS catalog table [2495](#)

JAR_DATA_ROWID column

SYSJAROBJECTS catalog table [2495](#)

JAR_ID column

SYSJARCONTENTS catalog table [2494](#)
SYSJAROBJECTS catalog table [2495](#)
SYSJAVA_OPTS catalog table [2496](#)
SYSJAVAPATHS catalog table [2497](#)
SYSROUTINES catalog table [2621](#)

JARSCHEMA column

SYSROUTINES catalog table [2621](#)

JARSCHEMA column

SYSJARCONTENTS catalog table [2494](#)
SYSJAROBJECTS catalog table [2495](#)
SYSJAVA_OPTS catalog table [2496](#)
SYSJAVAPATHS catalog table [2497](#)

JAVA_SIGNATURE column

SYSROUTINES catalog table [2621](#)

JDBC 4

JOBNAME clause

ALTER TRUSTED CONTEXT statement [1373](#)
CREATE TRUSTED CONTEXT statement [1791](#)

JOBNAME column of SYSCOPY catalog table [2408](#)

join operation

example [1048](#)
FROM clause of subselect [1036](#)
FULL OUTER JOIN
FROM clause of subselect [1034](#)
INNER JOIN
FROM clause of subselect [1034](#)
joining tables [1034](#)
LEFT OUTER JOIN
FROM clause of subselect [1034](#)
RIGHT OUTER JOIN
FROM clause of subselect [1034](#)
summary of results [1036](#)

JULIAN_DAY function [484](#)

K

Katakana character [75](#)

KATAKANA value for EBCDIC CCSID [75](#)

KEEPDYNAMIC column

SYSPACKAGE catalog table [2519](#)
SYSPLAN catalog table [2575](#)

key

length
maximum [2247](#)
partitioning index [1170](#), [1543](#), [2187](#)
primary
defining on a single column [1668](#)

key-expression clause

CREATE INDEX statement [1531](#)

KEYCOLUMNS column of SYSTABLES catalog table [2678](#)

KEYCOUNT column of SYSINDEXSTATS catalog table [2490](#)

KEYCOUNTF column

SYSINDEXSTATS catalog table [2490](#)
SYSINDEXSTATS_HIST catalog table [2492](#)

KEYGROUPKEYNO column

KEYGROUPKEYNO column (*continued*)
 SYSKEYTGTDIST catalog table [2509](#)
 SYSKEYTGTDIST_HIST catalog table [2513](#)
 SYSKEYTGTDISTSTATS catalog table [2511](#)

KEYLABEL column
 SYSTABLESPACE catalog table [2688](#)

KEYLABEL column
 SYSINDEXES catalog table [2461](#)

KEYOBID column of SYSTABLES catalog table [2678](#)

keys
 composite keys [10](#)
 foreign keys [10](#)
 parent keys [10](#)
 primary keys [10](#)
 unique keys [10](#)

KEYSEQ column
 SYSKEYTARGETS catalog table [2500](#)
 SYSKEYTARGETS_HIST catalog table [2505](#)
 SYSKEYTARGETSTATS catalog table [2503](#)
 SYSKEYTGTDIST catalog table [2509](#)
 SYSKEYTGTDIST_HIST catalog table [2513](#)
 SYSKEYTGTDISTSTATS catalog table [2511](#)

KEYSEQ column of SYSCOLUMNS catalog table [2381](#)

KEYTARGET_COUNT column
 SYSINDEXES catalog table [2461](#)

KEYVALUE column
 SYSKEYTGTDIST catalog table [2509](#)
 SYSKEYTGTDIST_HIST catalog table [2513](#)
 SYSKEYTGTDISTSTATS catalog table [2511](#)

keywords, reserved [2258](#)

L

LABEL
 column of SYSTABLES catalog table [2678](#)

LABEL column
 SYSCOLUMNS catalog table [2381](#)

LABEL statement
 description [2015](#)
 example [2016](#)

labeled duration [257](#)

labels [2210](#)

LABELS
 USING clause of DESCRIBE statement [1874](#), [1882](#)
 USING clause of PREPARE statement [2044](#)

LANGUAGE
 clause of ALTER FUNCTION statement [1103](#)
 clause of CREATE FUNCTION statement [1462](#), [1480](#)

LANGUAGE clause
 ALTER PROCEDURE (external) statement [1183](#)
 CREATE PROCEDURE (external) statement [1590](#)
 CREATE PROCEDURE (SQL - external) statement [1602](#)

LANGUAGE column
 SYSROUTINES catalog table [2621](#)

LANGUAGE SQL clause
 CREATE FUNCTION (inlined SQL scalar) statement [1494](#)
 CREATE FUNCTION statement [1435](#)
 CREATE PROCEDURE (SQL - native) statement [1617](#)

large object (LOB)
 description [116](#)

large object table spaces [50](#)

large objects (LOBs)
 data types [22](#)

LAST ROWSET clause

LAST ROWSET clause (*continued*)
 FETCH statement [1934](#)

LAST_DAY function [485](#)

LASTUSED
 column of SYSDYNQRY catalog table [2444](#)

LASTUSED column
 SYSINDEXSPACESTATS catalog table [2482](#)

LCASE function [486](#), [495](#)

LEAFDIST column
 SYSINDEXPART_HIST catalog table [2480](#)

LEAFDIST column of SYSINDEXPART catalog table
 description [2474](#)

LEAFFAR column
 SYSINDEXPART catalog table [2474](#)
 SYSINDEXPART_HIST catalog table [2480](#)

LEAFNEAR column
 SYSINDEXPART catalog table [2474](#)
 SYSINDEXPART_HIST catalog table [2480](#)

LEAST
 scalar function [486](#)

LEAST function [505](#)

LEAVE statement
 example [2234](#), [2293](#)
 SQL procedure [2234](#), [2293](#)

LEFT function [487](#)

LEFT OUTER JOIN
 example [1048](#)
 FROM clause of subselect [1034](#)

length attribute of column [103](#)

LENGTH column
 SYSCOLUMNS catalog table [2381](#)
 SYSCOLUMNS_HIST catalog table [2395](#)
 SYSDATATYPES catalog table [2429](#)
 SYSFIELDS catalog table [2456](#)
 SYSKEYTARGETS catalog table [2500](#)
 SYSKEYTARGETS_HIST catalog table [2505](#)
 SYSPARMS catalog table [2565](#)
 SYSVARIABLES catalog table [2724](#)

LENGTH function [489](#)

LENGTH2 column
 SYSCOLUMNS catalog table [2381](#)
 SYSCOLUMNS_HIST catalog table [2395](#)
 SYSKEYTARGETS catalog table [2500](#)
 SYSKEYTARGETS_HIST catalog table [2505](#)

letter, description in DB2 [75](#)

LIKE clause
 CREATE GLOBAL TEMPORARY TABLE statement [1521](#)
 CREATE TABLE statement [1686](#)
 DECLARE GLOBAL TEMPORARY TABLE statement [1836](#)

LIKE predicate [308](#)

LIMITKEY column
 SYSINDEXPART catalog table [2474](#)
 SYSTABLEPART catalog table [2665](#)

LIMITKEY_INTERNAL column
 SYSTABLEPART catalog table [2665](#)

limits, DB2 [2247](#)

LINK_OPTS column
 SYSROUTINES_OPTS catalog table [2635](#)

LINKNAME column
 IPLIST catalog table [2348](#)
 IPNAMES catalog table [2349](#)
 LOCATIONS catalog table [2351](#)
 LULIST catalog table [2353](#)
 USERNAMES catalog table [2737](#)

- links
 - non-IBM Web sites [2971](#)
- LISTAGG function [364](#)
- literal [170](#)
- LN function [490](#)
- LOAD privilege
 - GRANT statement [1969](#)
 - REVOKE statement [2079](#)
- LOADAUTH column of SYSDBAUTH catalog table [2432](#)
- LOADLASTTIME column
 - SYSTABLESPACESTATS catalog table [2699](#)
- LOADRLASTTIME column
 - SYSINDEXSPACESTATS catalog table [2482](#)
- LOB
 - restrictions [117](#)
- LOB (large object)
 - description [116](#)
 - file reference [232](#)
 - host variable [117](#)
 - locator [117](#), [230](#)
 - variable [230](#)
- LOBCOLUMNS column of SYSROUTINES catalog table [2621](#)
- local Db2 subsystem [68](#)
- locale
 - CURRENT LOCALE LC_CTYPE special register [196](#)
- LOCATE function [490](#)
- LOCATE_IN_STRING function [493](#)
- location
 - naming convention [82](#)
- LOCATION
 - column of SYSPACKAGE catalog table [2519](#)
 - column of SYSPACKAUTH catalog table [2536](#)
 - column of SYSPACKLIST catalog table [2558](#)
 - column of SYSPACKSTMT catalog table [2558](#)
 - column of SYSPKSYSTEM catalog table [2574](#)
 - column of SYSTABLES catalog table [2678](#)
- LOCATION column
 - LOCATIONS catalog table [2351](#)
- locator
 - LOB [117](#), [230](#)
 - result set [234](#)
- LOCATOR column of SYSPARMS catalog table [2565](#)
- locator variable
 - freeing [1949](#)
 - holding beyond a unit of work [1994](#)
- lock
 - ALTER TABLESPACE statement [1327](#)
 - CREATE LOB TABLESPACE statement [1558](#)
 - CREATE TABLESPACE statement [1731](#)
 - during update [2190](#)
 - LOCK TABLE statement [2017](#)
 - object
 - table space (table) [2017](#)
- LOCK TABLE statement
 - description [2017](#)
 - example [2018](#)
- locking [42](#)
- LOCKMAX clause
 - ALTER TABLESPACE statement
 - description [1327](#)
 - CREATE LOB TABLESPACE statement
 - description [1558](#)
 - CREATE TABLESPACE statement
- LOCKMAX clause (*continued*)
 - CREATE TABLESPACE statement (*continued*)
 - description [1730](#)
- LOCKMAX column
 - SYSTABLESPACE catalog table [2688](#)
- LOCKPART
 - clause of ALTER TABLESPACE statement [1341](#)
- LOCKPART clause
 - CREATE LOB TABLESPACE statement [1561](#)
 - CREATE TABLESPACE statement [1738](#)
- LOCKRULE column
 - SYSTABLESPACE catalog table [2688](#)
- locks [43](#), [55](#)
- LOCKSIZE clause
 - ALTER TABLESPACE statement
 - description [1327](#)
 - CREATE LOB TABLESPACE statement
 - description [1558](#)
 - CREATE TABLESPACE statement
 - description [1731](#)
- LOG
 - function [490](#)
- LOG column
 - SYSTABLESPACE catalog table [2688](#)
- LOG NO
 - clause of ALTER TABLESPACE statement [1341](#)
 - clause of CREATE LOB TABLESPACE statement [1561](#)
 - clause of CREATE TABLESPACE statement [1738](#)
- log range directory [39](#)
- LOG YES
 - clause of ALTER TABLESPACE statement [1341](#)
 - clause of CREATE LOB TABLESPACE statement [1561](#)
 - clause of CREATE TABLESPACE statement [1738](#)
- log range directory [39](#)
- LOG YES
 - clause of ALTER TABLESPACE statement [1341](#)
 - clause of CREATE LOB TABLESPACE statement [1561](#)
 - clause of CREATE TABLESPACE statement [1738](#)
- LOG10 function [494](#)
- LOGGED
 - clause of CREATE TABLE statement [1699](#)
- LOGGED clause
 - ALTER TABLESPACE statement [1328](#)
 - CREATE LOB TABLESPACE statement [1559](#)
 - CREATE TABLESPACE statement [1731](#)
 - DECLARE GLOBAL TEMPORARY TABLE statement [1839](#)
- LOGGED column
 - SYSCOPY catalog table [2408](#)
- logical operator [319](#)
- LOGICAL_PART column
 - SYSCOPY catalog table [2408](#)
 - SYSTABLEPART catalog table [2665](#)
- logs [40](#)
- long column string [112](#)
- LONG VARCHAR data type
 - description [103](#)
- LONG VARGRAPHIC data type
 - description [112](#)
- LOOP statement
 - example [2236](#), [2294](#)
 - SQL procedure [2236](#), [2294](#)
- low encryption [1791](#)
- LOW2KEY column
 - SYSCOLSTATS catalog table [2379](#)
 - SYSCOLUMNS catalog table [2381](#)
 - SYSCOLUMNS_HIST catalog table [2395](#)
 - SYSKEYTARGETS catalog table [2500](#)
 - SYSKEYTARGETS_HIST catalog table [2505](#)
 - SYSKEYTARGETSTATS catalog table [2503](#)

LOWDSNUM column of SYSCOPY catalog table [2408](#)
 LOWER function [495](#)
 lowercase character folded to uppercase [75](#)
 LOWKEY column
 SYSKEYTARGETSTATS catalog table [2503](#)
 LOWKEY column of SYSCOLSTATS catalog table [2379](#)
 LOWVALUE column
 SYSCOLDIST catalog table [2373](#)
 SYSCOLDIST_HIST catalog table [2377](#)
 SYSCOLDISTSTATS catalog table [2375](#)
 SYSKEYTGTDIST catalog table [2509](#)
 SYSKEYTGTDIST_HIST catalog table [2513](#)
 SYSKEYTGTDISTSTATS catalog table [2511](#)
 LPAD function [498](#)
 LTRIM function [500](#)
 LUNAME
 column of LULIST catalog table [2353](#)
 column of LUMODES catalog table [2353](#)
 column of LUNAMES catalog table [2354](#)
 column of MODESELECT catalog table [2358](#)

M

MAINTENANCE column
 SYSVIEWS catalog table [2730](#)
 mappings from SQL to XML [327](#)
 MASK clause
 COMMENT statement [1403](#)
 mask-name
 naming convention [82](#)
 materialized-query-definition
 CREATE TABLE statement [1691](#)
 MAX
 aggregate function [367](#)
 scalar function [501](#)
 MAX_CARDINALITY function [502](#)
 MAX_FAILURE column
 SYSROUTINES catalog table [2621](#)
 MAX_LOCKS_PER_TABLESPACE
 built-in global variable [331](#)
 MAX_LOCKS_PER_USER
 built-in global variable [331](#)
 MAXASSIGNEDVAL column of SYSSEQUENCES catalog table [2643](#)
 MAXPARTITIONS clause
 ALTER TABLESPACE statement [1329](#)
 CREATE TABLESPACE statement [1724](#)
 MAXPARTITIONS column
 SYSTABLESPACE catalog table [2688](#)
 MAXROWS
 clause of CREATE TABLESPACE statement [1732](#)
 MAXROWS clause
 ALTER TABLESPACE statement [1329](#)
 MAXROWS column
 SYSTABLESPACE catalog table [2688](#)
 MAXVALUE
 clause of ALTER SEQUENCE statement [1226](#)
 clause of CREATE TABLE statement [1676](#)
 MAXVALUE clause
 ALTER TABLE statement [1252](#)
 CREATE SEQUENCE statement [1641](#)
 MAXVALUE column of SYSSEQUENCES catalog table [2643](#)
 MEDIAN function [368](#)
 MEMBER CLUSTER

MEMBER CLUSTER (*continued*)
 clause of CREATE TABLE statement [1701](#)
 MEMBER CLUSTER clause
 CREATE TABLESPACE statement [1732](#)
 MEMBER_CLUSTER column
 SYSTABLESPACE catalog table [2688](#)
 MERGE statement
 description [2019](#)
 examples [2034](#)
 usage [2031](#)
 message
 precompiler processing of DECLARE TABLE statement [1850](#)
 METATYPE column of SYSDATATYPES catalog table [2429](#)
 MGMTCLAS clause
 CREATE STOGROUP statement [1230](#), [1647](#)
 MGMTCLAS column
 SYSSTOGROUP catalog table [2655](#)
 MICROSECOND function [503](#)
 MIDNIGHT_SECONDS function [504](#)
 MIN
 aggregate function [369](#)
 scalar function [505](#)
 MIN_DIVIDE_SCALE column
 SYSENVIRONMENT catalog table [2452](#)
 Minimum divide result scale [250](#)
 MINUTE function [505](#)
 MINVALUE
 clause of ALTER SEQUENCE statement [1225](#)
 clause of CREATE TABLE statement [1676](#)
 MINVALUE clause
 ALTER TABLE statement [1252](#)
 CREATE SEQUENCE statement [1640](#)
 MINVALUE column of SYSSEQUENCES catalog table [2643](#)
 MIXED column
 SYSDBRM catalog table [2437](#)
 SYSPACKAGE catalog table [2519](#)
 mixed data
 convention [xxvii](#)
 description [104](#)
 in string assignments [150](#)
 LIKE predicate [308](#)
 MIXED DATA
 field of panel DSNTIPF [102](#), [113](#), [325](#)
 mixed data character string columns [17](#)
 MIXED string subtype [17](#)
 MIXED_CCSID column
 SYSDATABASE catalog table [2427](#)
 SYSTABLESPACE catalog table [2688](#)
 MIXED_DATA column
 SYSENVIRONMENT catalog table [2452](#)
 MIXED_DATA session variable [336](#)
 MOD function [506](#)
 MODE DB2SQL clause [1764](#), [1784](#)
 MODE SQL clause of TRIGGER statement [1776](#)
 MODENAME column
 LUMODES catalog table [2353](#)
 MODESELECT catalog table [2358](#)
 MODESELECT column of LUNAMES catalog table [2354](#)
 MODIFIES SQL DATA clause
 ALTER FUNCTION statement [1105](#)
 ALTER PROCEDURE (external) statement [1185](#)
 ALTER PROCEDURE (SQL - native) statement [1203](#)
 CREATE FUNCTION statement [1437](#), [1464](#)

MODIFIES SQL DATA clause (*continued*)
 CREATE PROCEDURE (external) statement [1591](#)
 CREATE PROCEDURE (SQL - external) statement [1603](#)
 CREATE PROCEDURE (SQL - native) statement [1618](#)
 MON1AUTH column of SYSUSERAUTH catalog table [2715](#)
 MON2AUTH column of SYSUSERAUTH catalog table [2715](#)
 MONITOR1 privilege
 GRANT statement [1985](#)
 REVOKE statement [2098](#)
 MONITOR2 privilege
 GRANT statement [1985](#)
 REVOKE statement [2098](#)
 MONTH column
 SYSINDEXCONTROL catalog table [2460](#)
 MONTH function [508](#)
 MONTH_WEEK column
 SYSINDEXCONTROL catalog table [2460](#)
 MONTHNAME function [2959](#)
 MONTHS_BETWEEN function [508](#)
 MOVE_TO_ARCHIVE
 built-in global variable [332](#)
 MQREAD function [510](#)
 MQREADALL function [685](#)
 MQREADALLCLOB function [687](#)
 MQREADCLOB function [511](#)
 MQRECEIVE function [512](#)
 MQRECEIVEALL function [689](#)
 MQRECEIVEALLCLOB function [691](#)
 MQRECEIVECLOB function [514](#)
 MQSEND function [516](#)
 multiple-row-fetch clause
 FETCH statement [1937](#)
 MULTIPLY_ALT function [517](#)

N

NACTIVE column
 SYSINDEXSPACESTATS catalog table [2482](#)
 SYSTABLESPACE catalog table
 description [2688](#)
 SYSTABLESPACESTATS catalog table [2699](#)
 SYSTABSTATS catalog table [2710](#)
 NACTIVEF
 SYSTABLESPACE catalog table [2688](#)
 NAME
 column of SYSCOLDIST catalog table [2373](#)
 column of SYSCOLDISTSTATS catalog table [2375](#)
 column of SYSCOLSTATS catalog table [2379](#)
 column of SYSCOLUMNS catalog table [2381](#)
 column of SYSSEQUENCEAUTH catalog table [2640](#)
 NAME clause
 CREATE FUNCTION statement [1461](#)
 CREATE PROCEDURE (external) statement [1589](#)
 NAME column
 SYSCOLDIST_HIST catalog table [2377](#)
 SYSCOLUMNS_HIST catalog table [2395](#)
 SYSCONTEXT catalog table [2401](#)
 SYSTXTTRUSTATTRS catalog table [2426](#)
 SYSDATABASE catalog table [2427](#)
 SYSDATATYPES catalog table [2429](#)
 SYSDBAUTH catalog table [2432](#)
 SYSDBRM catalog table [2437](#)
 SYSFIELDS catalog table [2456](#)
 SYSINDEXES catalog table [2461](#)

NAME column (*continued*)
 SYSINDEXES_HIST catalog table [2472](#)
 SYSINDEXSPACESTATS catalog table [2482](#)
 SYSINDEXSTATS catalog table [2490](#)
 SYSINDEXSTATS_HIST catalog table [2492](#)
 SYSLOBSTATS catalog table [2516](#)
 SYSLOBSTATS_HIST catalog table [2516](#)
 SYSPACKAGE catalog table [2519](#)
 SYSPACKAUTH catalog table [2536](#)
 SYSPACKLIST catalog table [2558](#)
 SYSPACKSTMT catalog table [2558](#)
 SYSPARMS catalog table [2565](#)
 SYSPKSYSTEM catalog table [2574](#)
 SYSPLAN catalog table [2575](#)
 SYSPLANAUTH catalog table [2582](#)
 SYSRESAUTH catalog table [2615](#)
 SYSROLES catalog table [2618](#)
 SYSROUTINES catalog table [2621](#)
 SYSSEQUENCES catalog table [2643](#)
 SYSSTMT catalog table [2651](#)
 SYSSTOGROUP catalog table [2655](#)
 SYSSYNONYMS catalog table [2658](#)
 SYSTABLES catalog table [2678](#)
 SYSTABLES_HIST catalog table [2707](#)
 SYSTABLESPACE catalog table [2688](#)
 SYSTABLESPACESTATS catalog table [2699](#)
 SYSTABSTATS catalog table [2710](#)
 SYSTABSTATS_HIST catalog table [2711](#)
 SYSTRIGGERS catalog table [2712](#)
 SYSVARIABLEAUTH catalog table [2722](#)
 SYSVARIABLES catalog table [2724](#)
 SYSVIEWS catalog table [2730](#)
 names
 object naming conventions [79](#)
 NAMES
 USING clause of DESCRIBE statement [1882](#)
 NAMES
 USING clause of DESCRIBE statement [1874](#)
 USING clause of PREPARE statement [2044](#)
 names, prepared SQL statements [1844](#)
 naming conventions
 SQL [79](#)
 native SQL procedures [35](#)
 NEARINDREF column
 SYSTABLEPART catalog table [2665](#)
 SYSTABLEPART_HIST catalog table [2675](#)
 NEAROFFPOSF column
 SYSINDEXPART catalog table [2474](#)
 SYSINDEXPART_HIST catalog table [2480](#)
 Nested compound statements and scope of names [2210](#)
 nested table expressions [1020](#)
 NEW AS clause of CREATE TRIGGER statement [1349](#), [1747](#), [1774](#)
 new line control character [75](#)
 NEW TABLE AS clause of CREATE TRIGGER statement [1349](#), [1747](#), [1774](#)
 NEW TABLE clause [1764](#), [1784](#)
 NEW_LINE procedure [921](#)
 NEWAUTHID column of USERNAMES catalog table [2737](#)
 NEWFUN session variable [336](#)
 NEXT clause
 FETCH statement [1928](#)
 NEXT ROWSET clause
 FETCH statement [1932](#)

NEXT VALUE expression
 definition [292](#)
 NEXT_DAY function [518](#)
 NEXT_MONTH scalar function [520](#)
 NLEAF column
 SYSINDEXES catalog table
 description [2461](#)
 SYSINDEXES_HIST catalog table [2472](#)
 SYSINDEXSPACESTATS catalog table [2482](#)
 SYSINDEXSTATS catalog table [2490](#)
 SYSINDEXSTATS_HIST catalog table [2492](#)
 NLEVELS column
 SYSINDEXES catalog table
 description [2461](#)
 SYSINDEXES_HIST catalog table [2472](#)
 SYSINDEXSPACESTATS catalog table [2482](#)
 SYSINDEXSTATS catalog table [2490](#)
 SYSINDEXSTATS_HIST catalog table [2492](#)
 NO ACTION delete rule
 CREATE TABLE statement [1684](#)
 NO CACHE
 clause of ALTER SEQUENCE statement [1226](#)
 NO CACHE clause
 ALTER TABLE statement [1253](#)
 CREATE SEQUENCE statement [1642](#)
 NO CASCADE clause of CREATE TRIGGER statement [1348](#),
[1746](#)
 NO COLLID clause
 ALTER FUNCTION statement [1109](#)
 ALTER PROCEDURE (external) statement [1186](#)
 ALTER PROCEDURE (SQL - external) statement [1191](#)
 CREATE FUNCTION statement [1467](#), [1485](#)
 NO CYCLE
 clause of ALTER SEQUENCE statement [1226](#)
 NO CYCLE clause
 ALTER TABLE statement [1252](#)
 CREATE SEQUENCE statement [1641](#)
 NO DBINFO clause
 ALTER FUNCTION statement [1108](#)
 ALTER PROCEDURE (external) statement [1185](#)
 CREATE FUNCTION statement [1467](#), [1485](#)
 CREATE PROCEDURE (external) statement [1592](#)
 CREATE PROCEDURE (SQL - external) statement [1603](#)
 NO DEFAULT ROLE clause
 ALTER TRUSTED CONTEXT statement [1371](#)
 CREATE TRUSTED CONTEXT statement [1789](#)
 no encryption [1791](#)
 NO EXTERNAL ACTION clause
 ALTER FUNCTION statement [1106](#), [1122](#), [1147](#)
 CREATE FUNCTION (inlined SQL scalar) statement [1495](#)
 CREATE FUNCTION statement [1436](#), [1464](#), [1482](#)
 NO FINAL CALL clause
 ALTER FUNCTION statement [1108](#), [1466](#)
 CREATE FUNCTION statement [1484](#)
 NO MAXVALUE
 clause of ALTER SEQUENCE statement [1226](#)
 clause of CREATE TABLE statement [1676](#)
 NO MAXVALUE clause
 ALTER TABLE statement [1252](#)
 CREATE SEQUENCE statement [1641](#)
 NO MINVALUE
 clause of ALTER SEQUENCE statement [1225](#)
 clause of CREATE TABLE statement [1676](#)
 NO MINVALUE clause
 ALTER TABLE statement [1252](#)
 CREATE SEQUENCE statement [1640](#)
 NO ORDER
 clause of ALTER SEQUENCE statement [1227](#)
 clause of CREATE TABLE statement [1678](#)
 NO ORDER clause
 ALTER TABLE statement [1253](#)
 CREATE SEQUENCE statement [1642](#)
 NO PACKAGE PATH clause
 ALTER FUNCTION statement [1106](#)
 ALTER PROCEDURE (external) statement [1185](#)
 CREATE FUNCTION statement [1465](#), [1483](#)
 CREATE PROCEDURE (external) statement [1592](#)
 NO SCRATCHPAD clause
 ALTER FUNCTION statement [1107](#)
 CREATE FUNCTION statement [1465](#), [1483](#)
 NO SCROLL clause
 DECLARE CURSOR statement [1821](#)
 NO SQL clause
 ALTER FUNCTION statement [1105](#)
 ALTER PROCEDURE (external) statement [1185](#)
 CREATE FUNCTION statement [1464](#), [1482](#)
 CREATE PROCEDURE (external) statement [1591](#)
 NOCACHE clause
 CREATE SEQUENCE statement [1644](#)
 CREATE TABLE statement [1714](#)
 NOCOLLID clause
 CREATE PROCEDURE (external) statement [1593](#)
 CREATE PROCEDURE (SQL - external) statement [1603](#)
 NOCYCLE clause
 CREATE SEQUENCE statement [1644](#)
 CREATE TABLE statement [1714](#)
 NODDEFER PREPARE clause
 ALTER PROCEDURE (SQL - native) statement [1205](#)
 CREATE PROCEDURE (SQL - native) statement [1620](#)
 NOFOR option
 precompiler [326](#)
 NOGRAPHIC option of precompiler [325](#)
 NOMAXVALUE clause
 CREATE SEQUENCE statement [1644](#)
 CREATE TABLE statement [1714](#)
 NOMINVALUE clause
 CREATE SEQUENCE statement [1644](#)
 CREATE TABLE statement [1714](#)
 nonexecutable statement [1086](#), [1087](#)
 NOORDER clause
 CREATE SEQUENCE statement [1644](#)
 CREATE TABLE statement [1714](#)
 NORMALIZE_DECFLOAT function [520](#)
 NORMALIZE_STRING function [521](#)
 NOT ATOMIC clause
 compound statement of an SQL procedure [2221](#), [2286](#)
 NOT ATOMIC CONTINUE ON SQLEXCEPTION clause
 INSERT statement [2005](#)
 MERGE statement [2030](#)
 PREPARE statement [2049](#)
 NOT CLUSTER
 clause of ALTER INDEX statement [1167](#)
 NOT CLUSTER clause
 CREATE INDEX statement [1537](#)
 NOT DETERMINISTIC clause
 ALTER FUNCTION statement [1104](#), [1122](#), [1147](#)
 ALTER PROCEDURE (external) statement [1184](#)

NOT DETERMINISTIC clause (*continued*)
 ALTER PROCEDURE (SQL - external) statement [1191](#)
 ALTER PROCEDURE (SQL - native) statement [1203](#)
 CREATE FUNCTION (inlined SQL scalar) statement [1495](#)
 CREATE FUNCTION statement [1436](#), [1463](#), [1481](#)
 CREATE PROCEDURE (external) statement [1592](#)
 CREATE PROCEDURE (SQL - external) statement [1603](#)
 CREATE PROCEDURE (SQL - native) statement [1618](#)

NOT ENFORCED clause
 ALTER TABLE statement [1272](#)
 CREATE TABLE statement [1685](#)

NOT FOUND clause of WHENEVER statement [2204](#)

NOT LOGGED
 clause of CREATE TABLE statement [1699](#)

NOT LOGGED clause
 ALTER TABLESPACE statement [1328](#)
 CREATE LOB TABLESPACE statement [1559](#)
 CREATE TABLESPACE statement [1731](#)
 DECLARE GLOBAL TEMPORARY TABLE statement [1839](#)

NOT NULL clause
 ALTER TABLE statement [1248](#)
 CREATE GLOBAL TEMPORARY TABLE statement [1521](#)
 CREATE TABLE statement
 description [1667](#)
 DECLARE GLOBAL TEMPORARY TABLE statement [1836](#)

NOT PADDED
 clause of ALTER INDEX statement [1168](#)

NOT PADDED clause
 CREATE INDEX statement [1537](#)

NOT VARIANT clause
 CREATE PROCEDURE (external) statement [1596](#)
 CREATE PROCEDURE (SQL - external) statement [1606](#)
 CREATE PROCEDURE (SQL - native) statement [1635](#)

NOT VOLATILE
 clause of CREATE TABLE statement [1699](#)

NOT VOLATILE clause
 ALTER TABLE statement [1289](#)

NPAGES column
 SYSINDEXSPACESTATS catalog table [2482](#)
 SYSTABLES catalog table
 description [2678](#)
 SYSTABLESPACESTATS catalog table [2699](#)
 SYSTABSTATS catalog table [2710](#)
 SYSTABSTATS_HIST catalog table [2711](#)

NPAGESF column
 SYSCOPY catalog table [2408](#)
 SYSTABLES catalog table [2678](#)
 SYSTABLES_HIST catalog table [2707](#)

NTABLES column of SYSTABLESPACE catalog table [2688](#)

NULL
 CAST specification [267](#)
 predicate [316](#)

NULL CALL clause
 CREATE PROCEDURE (external) statement [1596](#)

null value
 assigned to target variable [2119](#)
 assignment [143](#)
 duplicate rows [1010](#)
 grouping columns [1037](#)
 specified by indicator variable [227](#)

null values
 compared to default values [26](#)
 usage [24](#)

NULL_CALL column of SYSROUTINES catalog table [2621](#)

NULLIF function [522](#)

NULLS column
 SYSCOLUMNS catalog table [2381](#)
 SYSCOLUMNS_HIST catalog table [2395](#)
 SYSKEYTARGETS catalog table [2500](#)
 SYSKEYTARGETS_HIST catalog table [2505](#)

NULLS LAST clause
 ALTER TABLE statement [1275](#)
 CREATE TABLE statement [1695](#)

NUM_DEP_MQTS column
 SYSROUTINES catalog table [2621](#)
 SYSTABLES catalog table [2678](#)

numbers
 data types
 string representation [101](#)

numbers in SQL [99](#)

NUMCOLUMNS column
 SYSCOLDIST catalog table [2373](#)
 SYSCOLDIST_HIST catalog table [2377](#)
 SYSCOLDISTSTATS catalog table [2375](#)

numeric
 assignments [145](#)
 comparisons [156](#)
 data type [99](#)
 operands [167](#)

NUMERIC data type
 CREATE TABLE statement [1663](#)

numeric data types
 DECIMAL [19](#)
 DOUBLE [19](#)
 identity columns [19](#)
 INTEGER [19](#)
 REAL [19](#)
 SMALLINT [19](#)

NUMKEYS column
 SYSKEYTGTDIST catalog table [2509](#)
 SYSKEYTGTDIST_HIST catalog table [2513](#)
 SYSKEYTGTDISTSTATS catalog table [2511](#)

NUMPARTS
 clause of CREATE TABLESPACE statement [1726](#)

NVL function [523](#)

O

OBID
 clause of CREATE TABLE statement [1698](#)
 column of SYSCHECKS catalog table [2369](#)
 column of SYSTABLES catalog table [2678](#)
 column of SYSTABLESPACE catalog table [2688](#)
 column of SYSTRIGGERS catalog table [2712](#)

OBID column
 SYSINDEXES catalog table [2461](#)

object name, resolution [86](#)

object ownership [90](#)

object table [220](#)

OBJECTOWNERTYPE column
 SYSCONTEXT catalog table [2401](#)

objects
 naming conventions [79](#)

OBTYPE column of SYSRESAUTH catalog table [2615](#)

OCTETS [106](#)

ODBC (Open Database Connectivity) [3](#)

OFFSET clause
 subselect-statement [1046](#)

- OLAP-specification
 - expression [280](#)
- OLD AS clause of TRIGGER statement [1774](#)
- OLD ROW AS clause of TRIGGER statement [1349](#), [1747](#)
- OLD TABLE AS clause of CREATE TRIGGER statement [1349](#), [1747](#), [1774](#)
- OLD TABLE clause
 - FROM clause [1022](#)
- OLDEST_VERSION column
 - catalog table [2688](#)
 - SYSCOPY catalog table [2408](#)
 - SYSINDEXES catalog table [2461](#)
 - SYSINDEXPART catalog table [2474](#)
 - SYSTABLEPART catalog table [2665](#)
- ON clause
 - CREATE INDEX statement [1530](#)
 - CREATE TRIGGER statement [1746](#), [1773](#)
 - joining tables [1034](#)
- ON COMMIT clause
 - DECLARE GLOBAL TEMPORARY TABLE statement [1839](#)
- ON DELETE clause
 - ALTER TABLE statement [1271](#)
 - CREATE TABLE statement [1684](#)
- ON ROLLBACK RETAIN CURSORS clause
 - SAVEPOINT statement [2114](#)
- ON ROLLBACK RETAIN LOCKS clause
 - SAVEPOINT statement [2114](#)
- ON search condition
 - MERGE statement [2026](#)
- ON TABLE clause
 - GRANT statement [1989](#)
 - REVOKE statement [2102](#)
- one-phase commit [68](#)
- OPEN
 - statement
 - description [2037](#)
 - example [2041](#)
- open cursor [1941](#)
- Open Database Connectivity (ODBC) [3](#)
- operands
 - binary string [168](#)
 - character string [168](#)
 - datetime [169](#), [257](#)
 - decimal [250](#)
 - distinct type [250](#)
 - graphic string [168](#)
 - integer [250](#)
 - numeric [167](#)
 - Row ID [169](#)
 - XML [169](#)
- operation
 - SQL
 - assignment [143](#)
 - comparison [156](#)
 - description [143](#)
- OPERATIVE column
 - SYSPACKAGE catalog table [2519](#)
 - SYSPLAN catalog table [2575](#)
- operator
 - arithmetic [250](#)
- OPTHINT clause
 - ALTER PROCEDURE (SQL - native) statement [1209](#)
 - CREATE PROCEDURE (SQL - native) statement [1128](#), [1442](#), [1624](#)
- OPTHINT clause (*continued*)
 - CREATE TRIGGER statement [1354](#), [1752](#)
- OPTHINT column
 - SYSPACKAGE catalog table [2519](#)
 - SYSPLAN catalog table [2575](#)
- optimization hints [1128](#), [1209](#), [1354](#), [1442](#), [1624](#), [1752](#)
- OPTIMIZE FOR n ROWS clause [1073](#)
- OR truth table [319](#)
- ORDER
 - clause of ALTER SEQUENCE statement [1227](#)
 - clause of CREATE TABLE statement [1678](#)
- ORDER BY clause
 - subselect [1043](#)
- ORDER clause
 - ALTER TABLE statement [1253](#)
 - CREATE SEQUENCE statement [1642](#)
- ORDER column of SYSSEQUENCES catalog table [2643](#)
- ORDER OF clause
 - ORDER BY clause of subselect [1044](#)
- order of evaluation, operators [263](#)
- order of statements in a compound statement [2221](#), [2286](#)
- ORDERING column
 - SYSKEYTARGETS catalog table [2500](#)
- ORDERING column of SYSKEYS catalog table [2498](#)
- ORDINAL column
 - SYSJAVAPATHS catalog table [2497](#)
- ORDINAL column of SYSPARMS catalog table [2565](#)
- ordinary identifier in SQL [77](#)
- ORGANIZATIONTYPE column
 - SYSTABLESPACE catalog table [2688](#)
- ORGRATIO column
 - SYSLOBSTATS catalog table [2516](#)
 - SYSLOBSTATS_HIST catalog table [2516](#)
- ORIGIN column
 - SYSPACKAGE catalog table [2519](#)
- ORIGIN column of SYSROUTINES catalog table [2621](#)
- ORIGINAL_ENCODING_CCSID column
 - SYSENVIRONMENT catalog table [2452](#)
- ORIGINALTS column
 - SYSTRIGGERS catalog table [2712](#)
- OTYPE column of SYSCOPY catalog table [2408](#)
- OUT clause
 - ALTER PROCEDURE (SQL - native) statement [1202](#)
 - CREATE PROCEDURE (external) statement [1586](#)
 - CREATE PROCEDURE (SQL - external) statement [1601](#)
 - CREATE PROCEDURE (SQL - native) statement [1616](#)
- OUTCCSID column of SYSSTRINGS catalog table [2656](#)
- outer join
 - FULL OUTER JOIN
 - example [1048](#)
 - FROM clause of subselect [1034](#)
 - LEFT OUTER JOIN
 - example [1048](#)
 - FROM clause of subselect [1034](#)
 - RIGHT OUTER JOIN
 - example [1048](#)
 - FROM clause of subselect [1034](#)
- output host variable [227](#)
- OVERLAY function [523](#)
- OVERRIDING USER VALUE
 - clause of INSERT statement [2001](#)
- OWNER
 - column of SYSDATATYPES catalog table [2429](#)
 - column of SYSINDEXSTATS catalog table [2490](#)

OWNER (continued)

- column of SYSINDEXSTATS_HIST catalog table [2492](#)
- column of SYSJAROBJECTS catalog table [2495](#)
- column of SYSPACKAGE catalog table [2519](#)
- column of SYSPARMS catalog table [2565](#)
- column of SYSROUTINES catalog table [2621](#)
- column of SYSSEQUENCES catalog table [2643](#)
- column of SYSTABSTATS catalog table [2710](#)
- column of SYSTABSTATS_HIST catalog table [2711](#)
- column of SYSTRIGGERS catalog table [2712](#)

OWNER column

- SYSINDEXES catalog table [2461](#)
- SYSJAVAPATHS catalog table [2497](#)
- SYSTABLES catalog table [2678](#)
- SYSVARIABLES catalog table [2724](#)
- SYSVIEWS catalog table [2730](#)

ownership

- transferring
 - TRANSFER OWNERSHIP statement [2172](#)

OWNERTYPE column

- SYSCONSTDEP catalog table [2400](#)
- SYSDATABASE catalog table [2429](#)
- SYSINDEXES catalog table [2461](#)
- SYSJAROBJECTS catalog table [2495](#)
- SYSPACKAGE catalog table [2519](#)
- SYSPARMS catalog table [2565](#)
- SYSROUTINES catalog table [2621](#)
- SYSSEQUENCES catalog table [2643](#)
- SYSTABLES catalog table [2678](#)
- SYSTABLESPACE catalog table [2712](#)
- SYSVARIABLES catalog table [2724](#)
- SYSVIEWDEP catalog table [2729](#)
- SYSVIEWS catalog table [2730](#)

P

PACK function [526](#)

PACKADM authority

- GRANT statement [1967](#)
- REVOKE statement [2076](#)

package

- binding
 - remote [96](#)
- dropping [1894](#)
- privileges
 - granting [1975](#)
 - remote bind [96](#)
 - revoking [2087](#)

PACKAGE

- clause of GRANT statement [1976](#)
- clause of REVOKE statement [2088](#)

PACKAGE clause

- COMMENT statement [1403](#)
- DROP statement [1894](#)

PACKAGE OWNER clause

- ALTER PROCEDURE (SQL - native) statement [1204](#)
- CREATE PROCEDURE (SQL - native) statement [1124](#), [1438](#), [1619](#)

PACKAGE PATH clause

- ALTER FUNCTION statement [1106](#)
- ALTER PROCEDURE (external) statement [1185](#)
- CREATE FUNCTION statement [1465](#), [1483](#)
- CREATE PROCEDURE (external) statement [1592](#)

PACKAGE_NAME session variable [336](#)

PACKAGE_SCHEMA session variable [336](#)

PACKAGE_VERSION session variable [336](#)

package-name

- naming convention [82](#)

PACKAGEPATH column

- SYSROUTINES catalog table [2621](#)

packages [45](#), [57](#)

PAD_NUL_TERMINATED session variable [336](#)

PADDED clause

- ALTER INDEX statement [1168](#)
- CREATE INDEX statement [1537](#)

PADDED column

- SYSINDEXES catalog table [2461](#)

page sets [48](#)

PAGENUM

- clause of CREATE TABLE statement [1701](#)

PAGENUM column

- SYSINDEXES catalog table [2461](#)
- SYSTABLESPACE catalog table [2688](#)

PAGESAVE column

- SYSTABLEPART catalog table [2665](#)
- SYSTABLEPART_HIST catalog table [2675](#)

PARALLEL column of SYSROUTINES catalog table [2621](#)

parallel processing

- SET CURRENT DEGREE statement [2136](#)

Parallel Sysplex

- group buffer pool [41](#)

parameter

- passing to stored procedure [2218](#), [2282](#)

PARAMETER CCSID ASCII clause

- ALTER PROCEDURE (SQL - native) statement [1204](#)

PARAMETER CCSID clause

- CREATE FUNCTION (inlined SQL scalar) statement [1495](#)
- CREATE FUNCTION (SQL - native) statement [1438](#)
- CREATE FUNCTION statement [1460](#), [1479](#), [1504](#)
- CREATE PROCEDURE (external) statement [1588](#)
- CREATE PROCEDURE (SQL - external) statement [1602](#)
- CREATE PROCEDURE (SQL - native) statement [1619](#)

PARAMETER CCSID EBCDIC clause

- ALTER PROCEDURE (SQL - native) statement [1204](#)

PARAMETER CCSID UNICODE clause

- ALTER PROCEDURE (SQL - native) statement [1204](#)

parameter marker

- CAST specification [267](#)
- description [2051](#)
- EXECUTE statement [1910](#)
- EXPLAIN statement [1919](#)
- obtaining information with DESCRIBE INPUT [1871](#)
- OPEN statement [2039](#)
- PREPARE statement [2051](#)
- rules [2051](#)
- typed [2051](#)
- untyped [2051](#)
- variables in dynamic SQL [230](#)

PARAMETER STYLE clause

- ALTER FUNCTION statement [1104](#)
- ALTER PROCEDURE (external) statement [1184](#)
- CREATE FUNCTION statement [1462](#), [1481](#)
- CREATE PROCEDURE (external) statement [1591](#)

PARAMETER STYLE DB2SQL clause

- CREATE PROCEDURE (external) statement [1596](#)

PARAMETER VARCHAR clause

- CREATE FUNCTION statement [1460](#), [1479](#)
- CREATE PROCEDURE (external) statement [1588](#)

PARAMETER_CCSID column
 SYSROUTINES catalog table [2621](#)
 PARAMETER_STYLE column of SYSROUTINES catalog table [2621](#)
 PARAMETER_VARCHARFORM column
 SYSROUTINES catalog table [2621](#)
 parameter-name
 naming convention [82](#)
 parent keys [10](#), [12](#)
 parent rows [12](#)
 parent tables [12](#)
 PARENTS column of SYSTABLES catalog table [2678](#)
 PARM_COUNT column of SYSROUTINES catalog table [2621](#)
 PARM_SIGNATURE column of SYSROUTINES catalog table [2621](#)
 PARM1 - PARM30 columns of SYSROUTINES catalog table [2621](#)
 PARMLIST column
 SYSFIELDS catalog table [2456](#)
 PARMNAME column of SYSPARMS catalog table [2565](#)
 PARSETREE column
 SYSINDEXES catalog table [2461](#)
 PART
 clause of CREATE AUXILIARY TABLE statement [1420](#)
 PART clause
 CREATE INDEX statement [1551](#)
 CREATE LOB TABLESPACE statement [1561](#)
 CREATE TABLE statement [1714](#)
 CREATE TABLESPACE statement [1738](#)
 synonym for PARTITION clause [2018](#)
 partition
 maximum size [1161](#), [1557](#)
 PARTITION
 clause of ALTER INDEX statement [1170](#)
 clause of CREATE INDEX statement [1543](#)
 clause of CREATE TABLESPACE statement [1726](#)
 clause of LOCK TABLE statement [2017](#)
 PARTITION BY RANGE
 clause of CREATE INDEX statement [1542](#)
 PARTITION BY RANGE clause
 ALTER TABLE statement [1274](#)
 CREATE TABLE statement [1695](#)
 PARTITION BY SIZE clause
 CREATE TABLE statement [1694](#)
 PARTITION clause
 ALTER TABLE statement [1275](#)
 CREATE TABLE statement [1695](#)
 PARTITION column
 SYSCOLDISTSTATS catalog table [2375](#)
 SYSCOLSTATS catalog table [2379](#)
 SYSINDEXCONTROL catalog table [2460](#)
 SYSINDEXPART catalog table [2474](#)
 SYSINDEXPART_HIST catalog table [2480](#)
 SYSINDEXSPACESTATS catalog table [2482](#)
 SYSINDEXSTATS catalog table [2490](#)
 SYSINDEXSTATS_HIST catalog table [2492](#)
 SYSKEYTARGETSTATS catalog table [2503](#)
 SYSKEYTGTDISTSTATS catalog table [2511](#)
 SYSTABLEPART catalog table [2665](#)
 SYSTABLEPART_HIST catalog table [2675](#)
 SYSTABLESPACE catalog table [2688](#)
 SYSTABLESPACESTATS catalog table [2699](#)
 SYSTABSTATS catalog table [2710](#)
 SYSTABSTATS_HIST catalog table [2711](#)
 PARTITION column of SYSAUXRELS catalog table [2368](#)
 partition-by-clause
 CREATE TABLE statement [1694](#)
 PARTITIONED clause
 CREATE INDEX statement [1537](#)
 partitioned table spaces [50](#)
 PARTITIONS column
 SYSINDEXES catalog table [2461](#)
 PARTKEY_COLSEQ column
 SYSCOLUMNS catalog table [2381](#)
 PARTKEY_ORDERING column
 SYSCOLUMNS catalog table [2381](#)
 PARTKEYCOLNUM column
 SYSTABLES catalog table [2678](#)
 PASSWORD column
 USERNAMES catalog table [2737](#)
 password, encryption [2161](#)
 PATH column
 SYSJAROBJECTS catalog table [2495](#)
 PATHSCHEMAS column
 SYSCHECKS2 catalog table [2370](#)
 SYSENVIRONMENT catalog table [2452](#)
 SYSPACKAGE catalog table [2519](#)
 SYSPLAN catalog table [2575](#)
 SYSVIEWS catalog table [2730](#)
 PCTFREE
 clause of ALTER INDEX statement [1166](#)
 clause of CREATE INDEX statement [1540](#)
 clause of CREATE TABLESPACE statement [1729](#)
 column of SYSINDEXPART catalog table [2474](#)
 column of SYSTABLEPART catalog table [2665](#)
 PCTFREE clause
 ALTER TABLESPACE statement [1331](#)
 PCTFREE column
 SYSINDEXES catalog table [2461](#)
 SYSTABLESPACE catalog table [2688](#)
 PCTFREE_UPD column
 SYSTABLEPART catalog table [2665](#)
 SYSTABLESPACE catalog table [2688](#)
 PCTFREE_UPD_CALC column
 SYSTABLEPART catalog table [2665](#)
 SYSTABLESPACE catalog table [2688](#)
 PCTIMESTAMP column of SYSPACKAGE catalog table [2519](#)
 PCTPAGES column
 SYSTABLES catalog table [2678](#)
 SYSTABLES_HIST catalog table [2707](#)
 SYSTABSTATS catalog table [2710](#)
 PCTROWCOMP column
 SYSTABLES catalog table
 description [2678](#)
 SYSTABLES_HIST catalog table [2707](#)
 SYSTABSTATS catalog table [2710](#)
 PDSNAME column
 SYSDBRM catalog table [2437](#)
 SYSPACKAGE catalog table [2519](#)
 PE_CLASS_PATTERN column
 SYSJAVAPATHS catalog table [2497](#)
 PE_JAR_ID column
 SYSJAVAPATHS catalog table [2497](#)
 PE_JARSCHEMA column
 SYSJAVAPATHS catalog table [2497](#)
 PER_STMT_ID
 column of SYSDYNQRYDEP catalog table [2446](#)
 PERACTIVE column

PERCACTIVE column (*continued*)
 SYSTABLEPART catalog table
 description [2665](#)
 SYSTABLEPART_HIST catalog table [2675](#)

PERCDROP column
 SYSTABLEPART catalog table
 description [2665](#)
 SYSTABLEPART_HIST catalog table [2675](#)

PERCENT_RANK function [372](#)

PERCENTILE_CONT function [370](#)

PERCENTILE_DISC function [371](#)

PERIOD option of precompiler [323](#)

PERMISSION clause
 COMMENT statement [1403](#)

permission-name
 naming convention [82](#)

PGSIZE column
 SYSINDEXES catalog table [2461](#)
 SYSTABLESPACE catalog table [2688](#)

PIECESIZE clause
 ALTER INDEX statement [1162](#)
 CREATE INDEX statement [1545](#)

PIECESIZE column
 SYSINDEXES catalog table [2461](#)

PIT_RBA column of SYSCOPY catalog table [2408](#)

PIT_RBA_EX column
 SYSCOPY catalog table [2408](#)

PKSIZE column of SYSPACKAGE catalog table [2519](#)

PL/I application program
 host structure [235](#)
 host variable
 description [227](#)
 host-variable-arrays [236](#)
 INCLUDE SQLCA [2308](#)
 INCLUDE SQLDA [2326](#)
 varying-length string [104](#)

PLAN
 clause of EXPLAIN statement [1919](#)

PLAN
 clause of GRANT statement [1977](#)
 clause of REVOKE statement [2089](#)

PLAN clause
 COMMENT statement [1403](#)

plan element [2146](#)

plan table
 column descriptions [2787](#)
 creating [2787](#)
 format [2787](#)
 SET CURRENT EXPLAIN MODE statement [2137](#)

PLAN_NAME session variable [336](#)

PLAN_TABLE
 column descriptions [2787](#)

plan-name
 naming convention [82](#)

PLANNAME column
 DSNPROGAUTH table [2939](#)
 MODESELECT catalog table [2358](#)
 SYSPACKLIST catalog table [2558](#)

PLCREATOR column
 SYSDBRM catalog table [2437](#)
 SYSSTMT catalog table [2651](#)

PLCREATOR_TYPE column
 SYSDBRM catalog table [2437](#)
 SYSSTMT catalog table [2651](#)

PLENTRIES column of SYSPLAN catalog table [2575](#)

PLNAME column
 SYSDBRM catalog table [2437](#)
 SYSSTMT catalog table [2651](#)

PLSIZE column of SYSPLAN catalog table [2575](#)

POBJECT_LIB column
 SYSJAVAOPTS catalog table [2496](#)

points of consistency [43](#), [55](#)

PORT column
 LOCATIONS catalog table [2351](#)

POSITION function [529](#)

POSSTR function [532](#)

POWER function [533](#)

PQTY column
 SYSINDEXES catalog table [2461](#)
 SYSINDEXPART catalog table [2474](#)
 SYSINDEXPART_HIST catalog table [2480](#)
 SYSTABLEPART catalog table [2665](#)
 SYSTABLEPART_HIST catalog table [2675](#)
 SYSTABLESPACE catalog table [2688](#)

precedence of operators [263](#)

PRECISION column
 SYSSEQUENCES catalog table [2643](#)

precision of numbers
 description [99](#)
 determined by SQLLEN variable [2322](#)
 in assignments [145](#)
 in comparisons [156](#)
 results of arithmetic operations [250](#)
 values for data types [99](#)

PRECOMPILE_OPTS column of SYSROUTINES_OPTS catalog table [2635](#)

precompiler
 checks SQL statements [1847](#)
 DECLARE TABLE statement [1845](#)
 DECLARE VARIABLE statement [1850](#)
 escape character [77](#)
 options
 COBOL decimal point [323](#)
 CONNECT [320](#)
 date [325](#)
 NOFOR [326](#)
 STDSQL [326](#)
 string delimiter [324](#)
 time [325](#)
 SET CURRENT ACCELERATOR statement [2129](#)
 SET CURRENT APPLICATION ENCODING SCHEME statement [2132](#)
 using INCLUDE statements [1995](#)

PRECOMPTS column of SYSDBRM catalog table [2437](#)

predicate
 ARRAY_EXISTS [302](#)
 basic [297](#)
 BETWEEN [303](#)
 description [296](#)
 DISTINCT [304](#)
 EXISTS [305](#)
 IN [306](#)
 LIKE [308](#)
 NULL [316](#)
 quantified [300](#)
 XMLEXISTS [316](#)

predicate selectivity table
 column descriptions [2863](#)

predicate selectivity table (*continued*)
 creating [2863](#)
 format [2863](#)
 prefix operator [250](#)
 PRELINK_OPTS column
 SYSROUTINES_OPTS catalog table [2635](#)
 PREPARE statement
 description [2042](#)
 example [2061](#)
 prepared SQL statement
 dynamically prepared by PREPARE [2042](#)
 executing [1909](#)
 identifying by DECLARE [1844](#)
 obtaining information
 with DESCRIBE [1873](#)
 with DESCRIBE INPUT [1871](#)
 SQLDA provides information [2313](#)
 statements allowed [2269](#)
 PREVIOUS VALUE expression
 definition [292](#)
 PRIMARY KEY clause
 ALTER TABLE statement
 description [1268](#)
 CREATE TABLE statement [1668](#), [1681](#)
 primary keys [10](#)
 PRIOR clause
 FETCH statement [1929](#)
 PRIOR ROWSET clause
 FETCH statement [1933](#)
 PRIQTY clause
 ALTER INDEX statement [1163](#)
 ALTER TABLESPACE statement [1332](#)
 CREATE INDEX statement [1538](#)
 privilege
 granting [1963](#)
 revoking [2070](#)
 types [1963](#)
 PRIVILEGE column of SYSCOLAUTH catalog table [2371](#)
 privileges
 object ownership [90](#)
 procedure
 creating with CREATE PROCEDURE statement [1578](#)
 PROCEDURE clause
 COMMENT statement [1403](#)
 DROP statement [1895](#)
 procedure, stored
 naming convention [82](#)
 procedures
 CREATE_DGTT [916](#)
 creating
 with CREATE PROCEDURE (SQL - native) statement
 [1607](#)
 DISABLE [917](#)
 DSN_WLM_APPLENV [913](#)
 ENABLE [918](#)
 external SQL procedures [35](#)
 external stored procedures [35](#)
 GET_LINE [919](#), [923](#)
 GET_LINES [920](#)
 inheriting special registers [215](#)
 introduction [35](#)
 native SQL procedures [35](#)
 NEW_LINE [921](#)
 PUT [921](#)
 procedures (*continued*)
 PUT_LINE [922](#)
 WLM_SET_CLIENT_INFO [999](#)
 product-sensitive programming information, described [2970](#)
 PRODUCTID_EXT
 built-in global variable [332](#)
 PROGAUTH column
 SYSPLAN catalog table [2575](#)
 PROGMDCPAD column
 DSNPROGAUTH table [2939](#)
 PROGMDCVAL
 column of DSNPROGAUTH table [2939](#)
 PROGNAME column
 DSNPROGAUTH table [2939](#)
 program
 naming convention [83](#)
 program authorization tables
 indexes [2939](#)
 table space [2939](#)
 PROGRAM clause [1905](#)
 PROGRAM TYPE clause
 ALTER FUNCTION statement [1110](#)
 ALTER PROCEDURE (external) statement [1187](#)
 ALTER PROCEDURE (SQL - external) statement [1192](#)
 CREATE FUNCTION statement [1469](#), [1486](#)
 CREATE PROCEDURE (external) statement [1594](#)
 CREATE PROCEDURE (SQL - external) statement [1605](#)
 PROGRAM_TYPE column of SYSROUTINES catalog table
 [2621](#)
 programming interface information, described [2970](#)
 promotion of data types [129](#)
 PROPERTIES column
 SYSIBM.XSROBJECTCOMPONENTS table [2783](#)
 SYSIBM.XSROBJECTPROPERTY table [2785](#)
 SYSIBM.XSROBJECTS table [2782](#)
 PSEUDO_DEL_ENTRIES column
 SYSINDEXPART catalog table [2474](#)
 SYSINDEXPART_HIST catalog table [2480](#)
 PSID column
 SYSINDEXSPACESTATS catalog table [2482](#)
 SYSTABLESPACE catalog table [2688](#)
 SYSTABLESPACESTATS catalog table [2699](#)
 PSPI symbols [2970](#)
 PUBLIC
 clause of CREATE ALIAS statement [1416](#)
 PUBLIC clause
 CREATE TRUSTED CONTEXT statement [1793](#)
 GRANT statement [1965](#)
 REVOKE statement [2071](#)
 PUBLICAUTH
 column of SYSDYNQRYDEP catalog table [2446](#)
 PUT procedure [921](#)
 PUT_LINE procedure [922](#)

Q

QMF for Workstation
 Database Explorer feature [4](#)
 query results [4](#)
 query-related features [4](#)
 SQL statements
 entering and processing [4](#)
 qualification of column names [220](#)
 QUALIFIER

QUALIFIER (*continued*)
 column of SYSPACKAGE catalog table [2519](#)
 column of SYSPLAN catalog table [2575](#)
 column of SYSRESAUTH catalog table [2615](#)
 unqualified object names [86](#)

QUALIFIER clause
 ALTER PROCEDURE (SQL - native) statement [1204](#)
 CREATE PROCEDURE (SQL - native) statement [1124](#),
[1438](#), [1619](#)
 CREATE TRIGGER statement [1351](#), [1749](#)

quantified predicate [300](#)

QUANTILENO column
 SYSCOLDIST catalog table [2373](#)
 SYSCOLDIST_HIST catalog table [2377](#)
 SYSCOLDISTSTATS catalog table [2375](#)
 SYSKEYTGTDIST catalog table [2509](#)
 SYSKEYTGTDIST_HIST catalog table [2513](#)
 SYSKEYTGTDISTSTATS catalog table [2511](#)

QUANTIZE function [534](#)

QUARTER function [535](#)

query [1007](#)

QUERY_HASH
 column of SYSDYNQRY catalog table [2444](#)

QUERY_HASH_VERSIO N
 column of SYSDYNQRY catalog table [2444](#)

QUERYNO clause
 DELETE statement [1863](#)
 INSERT statement [2003](#)
 SELECT INTO statement [2120](#)
 select-statement [1075](#)
 UPDATE statement [2190](#)

QUERYNO column
 SYSPACKSTMT catalog table [2558](#)
 SYSSTMT catalog table [2651](#)

question mark (?) [1910](#)

quotation mark [77](#), [324](#)

QUOTE
 column of SYSDBRM catalog table [2437](#)
 column of SYSPACKAGE catalog table [2519](#)
 option of precompiler [324](#)

QUOTESQL option of precompiler [324](#)

R

RACF (Resource Access Control Facility)
 security for remote execution [98](#)

RADIANS function [536](#)

RAISE_ERROR function [536](#)

RAND function [537](#)

RANDOM function [537](#)

RANK expression [280](#)

RBA column of SYSCHECKS catalog table [2369](#)

RBA_EX column
 SYSCHECKS catalog table [2369](#)

RBA_FORMAT column
 SYSINDEXPART catalog table [2474](#)
 SYSTABLEPART catalog table [2665](#)

RBA1 column of SYSTABLES catalog table [2678](#)

RBA1_EX column
 SYSTABLES catalog table [2678](#)

RBA2 column of SYSTABLES catalog table [2678](#)

RBA2_EX column
 SYSTABLES catalog table [2678](#)

READ SQL clause

READ SQL clause (*continued*)
 ALTER PROCEDURE (external) statement [1185](#)

READ SQL DATA clause
 ALTER FUNCTION statement [1105](#)

read-only
 FOR FETCH ONLY clause [1072](#)
 FOR READ ONLY clause [1072](#)
 view [1817](#)

READAUTH column
 SYSVARIABLEAUTH catalog table [2722](#)

READS SQL DATA clause
 ALTER PROCEDURE (SQL - external) statement [1191](#)
 ALTER PROCEDURE (SQL - native) statement [1203](#)
 CREATE FUNCTION (inlined SQL scalar) statement [1496](#)
 CREATE FUNCTION statement [1437](#), [1464](#), [1482](#)
 CREATE PROCEDURE (external) statement [1591](#)
 CREATE PROCEDURE (SQL - external) statement [1603](#)
 CREATE PROCEDURE (SQL - native) statement [1618](#)

REAL data type
 CREATE TABLE statement [1663](#)

REAL function [538](#)

real-time statistics
 stored procedure [848](#)

REBUILDLASTTIME column
 SYSINDEXSPACESTATS catalog table [2482](#)

RECLENGTH column of SYSTABLES catalog table [2678](#)

RECOVER privilege
 GRANT statement [1985](#)
 REVOKE statement [2098](#)

RECOVERAUTH column of SYSUSERAUTH catalog table [2715](#)

RECOVERDB privilege
 GRANT statement [1969](#)
 REVOKE statement [2079](#)

RECOVERDBAUTH column of SYSDBAUTH catalog table
[2432](#)

recovery
 COMMIT statement [1406](#)
 restoring data consistency [43](#), [55](#)
 unit of [44](#), [56](#)

REFCOLS column of SYSTABAUTH catalog table [2659](#)

REFERENCES clause
 ALTER TABLE statement [1270](#)

REFERENCES privilege
 GRANT statement [1989](#)
 REVOKE statement [2102](#)

REFERENCESAUTH column of SYSTABAUTH catalog table
[2659](#)

REFERENCING clause of TRIGGER statement [1349](#), [1747](#),
[1773](#)

referencing SQL parameters [2208](#)

referencing SQL variables [2208](#)

referential constraint
 ALTER TABLE statement [1269](#)
 CREATE TABLE statement [1682](#)

referential constraints [11](#), [12](#)

referential integrity [12](#)

REFRESH column
 SYSVIEWS catalog table [2730](#)

REFRESH TABLE statement
 description [2062](#)

REFRESH_TIME column
 SYSVIEWS catalog table [2730](#)

REFTBCREATOR column of SYSRELS catalog table [2613](#)

REFTBNAME column of SYSRELS catalog table [2613](#)

- REGENERATE clause
 - ALTER INDEX statement [1160](#)
 - ALTER VIEW statement [1379](#)
- REGENERATE VERSION clause
 - ALTER PROCEDURE (SQL - native) statement [1201](#)
- REGENERATETS column
 - SYSINDEXES catalog table [2461](#)
- REGENTS column
 - SYSTRIGGERS catalog table [2712](#)
- REGEXP_COUNT scalar function [539](#)
- REGEXP_INSTR scalar function [541](#)
- REGEXP_LIKE scalar function [543](#)
- REGEXP_REPLACE scalar function [546](#)
- REGEXP_SUBSTR scalar function [549](#)
- registering XML schema
 - XSR_REGISTER [1003](#)
- regression functions [374](#)
- RELATIVE clause
 - FETCH statement [1931](#)
- RELBND
 - column of SYSDYNQRY catalog table [2444](#)
- RELBOUND column
 - SYSPACKAGE catalog table [2519](#)
 - SYSPLAN catalog table [2575](#)
- RELCREATED column
 - SYSAUXRELS catalog table [2368](#)
 - SYSCHECKS catalog table [2369](#), [2370](#)
 - SYSCOLUMNS catalog table [2381](#)
 - SYSCONTEXT catalog table [2401](#)
 - SYSCOPY catalog table [2408](#)
 - SYSDATABASE catalog table [2427](#)
 - SYSDATATYPES catalog table [2429](#)
 - SYSDBRM catalog table [2437](#)
 - SYSENVIRONMENT catalog table [2452](#)
 - SYSIBM.XSROBJECTCOMPONENTS table [2783](#)
 - SYSIBM.XSROBJECTHIERARCHIES table [2784](#)
 - SYSIBM.XSROBJECTS table [2782](#)
 - SYSINDEXES catalog table [2461](#)
 - SYSKEYTARGETS catalog table [2500](#)
 - SYSRELS catalog table [2613](#)
 - SYSROLES catalog table [2618](#)
 - SYSROUTINES catalog table [2621](#)
 - SYSSEQUENCES catalog table [2643](#)
 - SYSSTOGROUP catalog table [2655](#)
 - SYSSYNONYMS catalog table [2658](#)
 - SYSTABCONST catalog table [2664](#)
 - SYSTABLEPART catalog table [2665](#)
 - SYSTABLES catalog table [2678](#)
 - SYSTABLESPACE catalog table [2688](#)
 - SYSTRIGGERS catalog table [2712](#)
 - SYSVARIABLES catalog table [2724](#)
 - SYSVIEWS catalog table [2730](#)
 - SYSVOLUMES catalog table [2733](#)
 - SYSXMLRELS catalog table [2734](#)
- RELEASE
 - column of SYSPACKAGE catalog table [2519](#)
 - column of SYSPLAN catalog table [2575](#)
- RELEASE (connection) statement
 - description [2063](#)
 - example [2064](#)
- RELEASE AT clause
 - ALTER PROCEDURE (SQL - native) statement [1210](#)
 - CREATE PROCEDURE (SQL - native) statement [1625](#)
 - CREATE TRIGGER statement [1355](#), [1753](#)
- release dependency indicators [2333](#)
- RELEASE SAVEPOINT statement
 - description [2065](#)
 - example [2065](#)
- release-pending connection state [70](#)
- RELNAME column
 - SYSFOREIGNKEYS catalog table [2458](#)
 - SYSRELS catalog table [2613](#)
- RELOBID1 column of SYSRELS catalog table [2613](#)
- RELOBID2 column of SYSRELS catalog table [2613](#)
- REMARKS column
 - SYSCOLUMNS catalog table [2381](#)
 - SYSCONTEXT catalog table [2401](#)
 - SYSDATATYPES catalog table [2429](#)
 - SYSIBM.XSROBJECTS table [2782](#)
 - SYSINDEXES catalog table [2461](#)
 - SYSPACKAGE catalog table [2519](#)
 - SYSPLAN catalog table [2575](#)
 - SYSROLES catalog table [2618](#)
 - SYSROUTINES catalog table [2621](#)
 - SYSSEQUENCES catalog table [2643](#)
 - SYSTABLES catalog table [2678](#)
 - SYSTRIGGERS catalog table [2712](#)
 - SYSVARIABLES catalog table [2724](#)
- REMOTE column of SYSPACKAGE catalog table [2519](#)
- remote database server
 - definition of [68](#)
- Remote Recovery Data Facility (RRDF) [1698](#)
- remote servers
 - accessing
 - with aliases [32](#)
- remote unit of work
 - connection management [72](#)
 - definition of [72](#)
- REMOVE VOLUMES clause of ALTER STOGROUP statement [1230](#)
- RENAME COLUMN clause
 - ALTER TABLE statement [1265](#)
- RENAME statement
 - description [2066](#)
 - example [2069](#)
- REOPT clause
 - ALTER PROCEDURE (SQL - native) statement [1212](#)
 - CREATE PROCEDURE (SQL - native) statement [1128](#), [1442](#), [1625](#)
- REOPTVAR column
 - SYSPACKAGE catalog table [2519](#)
 - SYSPLAN catalog table [2575](#)
- REORDMASSDELETE column
 - SYSINDEXSPACESTATS catalog table [2482](#)
 - SYSTABLESPACESTATS catalog table [2699](#)
- REORG privilege
 - GRANT statement [1969](#)
 - REVOKE statement [2079](#)
- REORG_LR_TS column
 - SYSTABLEPART catalog table [2665](#)
- REORGAPPENDINSERT column
 - SYSINDEXSPACESTATS catalog table [2482](#)
- REORGAUTH column of SYSDBAUTH catalog table [2432](#)
- REORGDELETES column
 - SYSINDEXSPACESTATS catalog table [2482](#)
 - SYSTABLESPACESTATS catalog table [2699](#)
- REORGDISORGLOB column
 - SYSTABLESPACESTATS catalog table [2699](#)

REORGFARINDREF column
 SYSTABLESPACESTATS catalog table [2699](#)
 REORGINSETS column
 SYSINDEXSPACESTATS catalog table [2482](#)
 SYSTABLESPACESTATS catalog table [2699](#)
 REORGLASTTIME column
 SYSINDEXSPACESTATS catalog table [2482](#)
 SYSTABLESPACESTATS catalog table [2699](#)
 REORGLEAFFAR column
 SYSINDEXSPACESTATS catalog table [2482](#)
 REORGLEAFNEAR column
 SYSINDEXSPACESTATS catalog table [2482](#)
 REORGNEARINDREF column
 SYSTABLESPACESTATS catalog table [2699](#)
 REORGNUMLEVELS column
 SYSINDEXSPACESTATS catalog table [2482](#)
 REORGPSEUDODELETES column
 SYSINDEXSPACESTATS catalog table [2482](#)
 REORGUNCLUSTINS column
 SYSTABLESPACESTATS catalog table
 description [2699](#)
 REORGUPDATES column
 SYSTABLESPACESTATS catalog table
 description [2699](#)
 REPAIR privilege
 GRANT statement [1969](#)
 REVOKE statement [2079](#)
 REPAIRAUTH column of SYSDBAUTH catalog table [2432](#)
 REPEAT function [551](#)
 REPEAT statement
 example [2237](#)
 SQL procedure [2237](#), [2295](#)
 REPLACE function [552](#)
 REPLACE USE FOR clause
 ALTER TRUSTED CONTEXT statement [1375](#)
 REPLACE VERSION clause
 ALTER PROCEDURE (SQL - native) statement [1200](#)
 REPLICATION_OVERRIDE
 built-in global variable [333](#)
 reserved keywords [2258](#)
 reserved schema names [2257](#)
 RESET
 clause of CONNECT statement [1410](#)
 RESET clause
 ALTER TABLE statement [1282](#)
 RESIGNAL statement
 example [2238](#), [2296](#)
 SQL procedure [2238](#), [2296](#)
 resource limit facility (governor)
 database [41](#)
 RESTART WITH
 clause of ALTER SEQUENCE statement [1225](#)
 RESTART WITH clause
 ALTER TABLE statement [1264](#)
 restarting a utility
 DSNUTILS [895](#)
 DSNUTILU [906](#)
 DSNUTILV [910](#)
 RESTARTWITH column
 SYSSEQUENCES catalog table [2643](#)
 RESTRICT
 delete rule
 ALTER TABLE statement [1271](#)
 CREATE TABLE statement [1684](#)
 RESTRICT clause of REVOKE statement [2072](#), [2105](#)
 RESTRICT WHEN DELETE TRIGGERS clause
 TRUNCATE statement [2177](#)
 result column
 data type [1014](#)
 names [1014](#)
 RESULT SET clause
 CREATE PROCEDURE (external) statement [1596](#)
 CREATE PROCEDURE (SQL - external) statement [1606](#)
 CREATE PROCEDURE (SQL - native) statement [1635](#)
 result set locator
 description [234](#)
 RESULT SETS clause
 CREATE PROCEDURE (external) statement [1596](#)
 CREATE PROCEDURE (SQL - external) statement [1606](#)
 CREATE PROCEDURE (SQL - native) statement [1635](#)
 RESULT_COLS column of SYSROUTINES catalog table [2621](#)
 RESULT_SETS column
 SYSROUTINES catalog table [2621](#)
 RETURN statement
 example [2298](#)
 examples [2240](#)
 SQL procedure [2240](#), [2298](#)
 RETURN STATUS clause [1962](#)
 RETURN_TYPE column of SYSROUTINES catalog table [2621](#)
 RETURN-statement clause
 CREATE FUNCTION (inlined SQL scalar) statement [1497](#)
 RETURNS clause
 CREATE FUNCTION (inlined SQL scalar) statement [1494](#)
 CREATE FUNCTION statement [1435](#)
 RETURNS clause of CREATE FUNCTION statement [1459](#),
[1503](#)
 RETURNS GENERIC TABLE clause
 CREATE FUNCTION statement [1479](#)
 RETURNS NULL ON NULL INPUT clause
 ALTER FUNCTION statement [1105](#)
 CREATE FUNCTION statement [1437](#), [1463](#), [1482](#)
 RETURNS TABLE clause
 CREATE FUNCTION statement [1478](#)
 REUSE STORAGE clause
 TRUNCATE statement [2176](#)
 REVOKE statement
 alternative syntax [1976](#), [2088](#)
 cascading effect [2072](#)
 collection privileges [2076](#)
 database privileges [2078](#)
 description [2070](#)
 function privileges [2081](#)
 JAR file privileges [2104](#)
 package privileges [2087](#)
 plan privileges [2089](#)
 procedure privileges [2081](#)
 schema privileges [2091](#)
 sequence privileges [2093](#)
 system privileges [2095](#)
 table privileges [2101](#)
 type privileges [2104](#)
 use privileges [2108](#)
 variable privileges [2106](#)
 view privileges [2101](#)
 REXX
 SQLCA [2310](#)
 SQLDA [2329](#)
 REXX SQLCA [2310](#)

- REXX SQLDA [2329](#)
- RID function [555](#)
- RIGHT function [556](#)
- RIGHT OUTER JOIN
 - example [1048](#)
 - FROM clause of subselect [1034](#)
- role
 - defining [1637](#)
 - naming convention [83](#)
- ROLE AS OBJECT OWNER clause
 - ALTER TRUSTED CONTEXT statement [1371](#)
 - CREATE TRUSTED CONTEXT statement [1789](#)
- ROLE clause
 - COMMENT statement [1403](#)
 - CREATE TRUSTED CONTEXT statement [1792](#)
 - DROP statement [1895](#)
 - GRANT statement [1965](#)
 - REVOKE statement [2071](#)
- ROLE column
 - SYSCONTEXTAUTHIDS catalog table [2404](#)
- ROLENAM column
 - SYSOBJROLEDEP catalog table [2517](#)
- rollback operations [42](#), [43](#), [55](#)
- ROLLBACK statement
 - description [2110](#)
 - example [2112](#)
- ROLLUP clause
 - examples [1054](#)
- ROTATE PARTITION FIRST TO LAST clause
 - ALTER TABLE statement [1281](#)
- ROTATE PARTITION integer TO LAST clause
 - ALTER TABLE statement [1281](#)
- ROUND function [558](#)
- ROUND_TIMESTAMP function [559](#)
- ROUNDING clause
 - ALTER PROCEDURE (SQL - native) statement [1213](#)
 - CREATE PROCEDURE (SQL - native) statement [1131](#), [1445](#), [1628](#)
 - CREATE TRIGGER statement [1355](#), [1754](#)
- ROUNDING column
 - SYSENVIRONMENT catalog table [2452](#)
 - SYSPACKAGE catalog table [2519](#)
 - SYSPLAN catalog table [2575](#)
- rounding mode
 - DECFLOAT values [323](#)
- routine versions
 - naming convention [83](#), [1435](#)
- ROUTINEID column
 - SYSPARMS catalog table [2565](#)
 - SYSROUTINES catalog table [2621](#)
- ROUTINENAME column
 - SYSROUTINES_OPTS catalog table [2635](#)
 - SYSROUTINES_SRC catalog table [2637](#)
- routines
 - functions [35](#)
 - inheriting special registers [215](#)
 - procedures [35](#)
 - types [35](#)
- ROUTINETYPE column
 - SYSPARMS catalog table [2565](#)
 - SYSROUTINEAUTH catalog table [2619](#)
 - SYSROUTINES catalog table [2621](#)
- row
 - deleting [1853](#)
- row (*continued*)
 - inserting [1996](#), [2019](#)
 - selecting single row [2117](#)
 - updating [2178](#)
- ROW CHANGE TIMESTAMP
 - expression [291](#)
- row change timestamp column
 - CREATE TABLE statement [1673](#)
- row change timestamp columns
 - ALTER TABLE statement [1254](#)
- ROW CHANGE TIMESTAMP expression
 - definition [291](#)
- ROW CHANGE TOKEN
 - expression [291](#)
- ROW CHANGE TOKEN expression
 - definition [291](#)
- row ID
 - assignment of values [153](#)
 - comparison of values [159](#)
 - data type [124](#), [1663](#)
- Row ID
 - operands [169](#)
- row permission
 - creating [1571](#)
- row permissions
 - altering [1177](#)
- ROW_NUMBER expression [280](#)
- row-positioned clause
 - FETCH statement [1928](#)
- row-value expression [296](#)
- ROWID
 - data type
 - CREATE TABLE statement [1663](#)
 - description [124](#)
 - function [563](#)
- ROWID column
 - SYSIBM.XSROBJECTCOMPONENTS table [2783](#)
 - SYSIBM.XSROBJECTS table [2782](#)
 - SYSINDEXES catalog table [2461](#)
 - SYSVARIABLES catalog table [2724](#)
- ROWID data type
 - default values [25](#)
- ROWNUMBER expression [280](#)
- rows
 - description [1](#)
 - inserting
 - with check constraints [27](#)
- ROWSET STARTING AT clause
 - FETCH statement [1934](#)
- rowset-positioned clause
 - FETCH statement [1932](#)
- rowset-positioning clause
 - DECLARE CURSOR statement [1824](#)
 - PREPARE statement [2047](#)
- ROWTYPE column of SYSPARMS catalog table [2565](#)
- RPAD function [563](#)
- RRDF (Remote Recovery Data Facility)
 - altering a table for [1288](#)
 - creating a table for [1698](#)
- RTRIM function [565](#)
- RTSECTION column
 - SYSINDEXES catalog table [2461](#)
- rules
 - naming conventions [79](#)

- run behavior for dynamic SQL statements [94](#)
- RUN OPTIONS clause
 - ALTER FUNCTION statement [1110](#)
 - ALTER PROCEDURE (external) statement [1187](#)
 - ALTER PROCEDURE (SQL - external) statement [1193](#)
 - CREATE FUNCTION statement [1469](#), [1487](#)
 - CREATE PROCEDURE (external) statement [1595](#)
 - CREATE PROCEDURE (SQL - external) statement [1605](#)
- RUNOPTS column
 - SYSROUTINES catalog table [2621](#)

S

- sample user-defined functions [2941](#)
- savepoint
 - naming convention [83](#)
 - releasing [2065](#)
 - setting [2113](#)
- SAVEPOINT statement
 - description [2113](#)
 - example [2114](#)
- SBCS data
 - description [104](#)
- SBCS string subtype [17](#)
- SBCS_CCSID column
 - SYSDATABASE catalog table [2427](#)
 - SYSTABLESPACE catalog table [2688](#)
- scalar [483](#)
- scalar-fullselect [256](#)
- SCALE column
 - SYSCOLUMNS catalog table [2381](#)
 - SYSDATATYPES catalog table [2429](#)
 - SYSFIELDS catalog table [2456](#)
 - SYSKEYTARGETS catalog table [2500](#)
 - SYSKEYTARGETS_HIST catalog table [2505](#)
 - SYSPARMS catalog table [2565](#)
 - SYSVARIABLES catalog table [2724](#)
- scale of numbers
 - comparisons [156](#)
 - results of arithmetic operations [250](#)
- schema
 - naming convention [83](#)
 - privileges [1978](#), [2091](#)
- SCHEMA
 - column of SYSSEQUENCEAUTH catalog table [2640](#)
- SCHEMA column
 - SYSDATATYPES catalog table [2429](#)
 - SYSPARMS catalog table [2565](#)
 - SYSROUTINEAUTH catalog table [2619](#)
 - SYSROUTINES catalog table [2621](#)
 - SYSROUTINES_OPTS catalog table [2635](#)
 - SYSROUTINES_SRC catalog table [2637](#)
 - SYSSEQUENCES catalog table [2643](#)
 - SYSTRIGGERS catalog table [2712](#)
 - SYSVARIABLEAUTH catalog table [2722](#)
 - SYSVARIABLES catalog table [2724](#)
- schema names [6](#)
- schema names, reserved [2257](#)
- schema qualifiers [6](#)
- SCHEMALOCATION column
 - SYSIBM.XSROBJECTCOMPONENTS table [2783](#), [2784](#)
 - SYSIBM.XSROBJECTS table [2782](#)
- SCHEMANAME column
 - SYSSCHEMAAUTH catalog table [2638](#)

- schemas [6](#)
- SCORE function [566](#)
- SCRATCHPAD clause
 - ALTER FUNCTION statement [1107](#)
 - CREATE FUNCTION statement [1465](#), [1483](#)
- SCRATCHPAD column of SYSROUTINES catalog table [2621](#)
- SCRATCHPAD_LENGTH column of SYSROUTINES catalog table [2621](#)
- SCREATOR column of SYSTABAUTH catalog table [2659](#)
- SCROLL clause
 - DECLARE CURSOR statement [1821](#)
- SCTO2 table space [39](#)
- search condition
 - DELETE statement [1861](#)
 - description [319](#)
 - HAVING clause [1043](#)
 - order of evaluation [319](#)
 - UPDATE statement [2188](#)
 - WHERE clause [1036](#)
- SECLABEL session variable [336](#)
- SECOND function [568](#)
- SECQTY clause
 - ALTER INDEX statement [1164](#)
 - ALTER TABLESPACE statement [1333](#)
 - CREATE INDEX statement [1539](#)
- SECQTY column
 - SYSINDEXES catalog table [2461](#)
- SECQTYI column
 - SYSINDEXPART catalog table [2474](#)
 - SYSINDEXPART_HIST catalog table [2480](#)
 - SYSTABLEPART catalog table [2665](#)
 - SYSTABLEPART_HIST catalog table [2675](#)
 - SYSTABLESPACE catalog table [2688](#)
- SECTNO column
 - SYSPACKSTMT catalog table [2558](#)
 - SYSSTMT catalog table [2651](#)
- SECTNOI column
 - SYSPACKSTMT catalog table [2558](#)
 - SYSSTMT catalog table [2651](#)
- SECURE column
 - LOCATIONS catalog table [2351](#)
- SECURITY clause
 - ALTER FUNCTION statement [1110](#)
 - ALTER PROCEDURE (external) statement [1187](#)
 - ALTER PROCEDURE (SQL - external) statement [1192](#)
 - CREATE FUNCTION statement [1469](#), [1486](#)
 - CREATE PROCEDURE (external) statement [1594](#)
 - CREATE PROCEDURE (SQL - external) statement [1605](#)
- SECURITY LABEL clause
 - CREATE TRUSTED CONTEXT statement [1792](#), [1793](#)
- SECURITY_IN column of LUNAMES catalog table [2354](#)
- SECURITY_LABEL column
 - SYSTABLES catalog table [2678](#)
- SECURITY_OUT column
 - IPNAMES catalog table [2349](#)
 - LUNAMES catalog table [2354](#)
- SECURITYLABEL column
 - SYSCONTEXTAUTHIDS catalog table [2404](#)
- segmented table spaces [50](#)
- segments [51](#)
- SEGSIZE
 - clause of CREATE TABLESPACE statement [1727](#)
 - column of SYSTABLESPACE catalog table [2688](#)
- SEGSIZE clause

SEGSIZE clause (*continued*)
 ALTER TABLESPACE statement [1330](#)

SELECT
 clause as syntax component [1010](#)

SELECT INTO statement
 description [2117](#)
 example [2121](#)

SELECT privilege
 GRANT statement [1989](#)
 REVOKE statement [2102](#)

SELECT statement
 common table expression [1069](#)
 description [1015](#), [1067](#), [2114](#)
 dynamic invocation [1089](#)
 example [1077](#)
 fullselect [1060](#)
 list
 application [1010](#)
 description [1010](#)
 maximum number of elements [2247](#)
 notation [1011](#)
 static invocation [1089](#)
 subselect [1009](#)

SELECTAUTH column of SYSTABAUTH catalog table [2659](#)

selecting
 single row [2117](#)

self-referencing tables [12](#)

SENSITIVE clause
 DECLARE CURSOR statement [1821](#)
 FETCH statement [1927](#)

SEQNO column
 SYSPACKLIST catalog table [2558](#)
 SYSPACKSTMT catalog table [2558](#)
 SYSROUTINES_SRC catalog table [2637](#)
 SYSSTMT catalog table [2651](#)
 SYSTRIGGERS catalog table [2712](#)
 SYSVIEWS catalog table [2730](#)

SEQTYPE column of SYSSEQUENCES catalog table [2643](#)

sequence
 ALTER SEQUENCE statement [1224](#)
 CREATE SEQUENCE statement [1638](#)
 dropping [1896](#)
 granting privileges [1979](#)
 name, unqualified [86](#)
 naming convention [83](#)
 reference [292](#)
 revoking privileges [2093](#)
 unqualified name [86](#)

SEQUENCE
 clause of ALTER SEQUENCE statement [1225](#)

SEQUENCE clause
 COMMENT statement [1403](#)
 CREATE SEQUENCE statement [1640](#)
 DROP statement [1896](#)
 GRANT statement [1979](#)
 REVOKE statement [2093](#)

SEQUENCEID column of SYSSEQUENCES catalog table [2643](#)

sequences [37](#)

SERVAUTH clause
 ALTER TRUSTED CONTEXT statement [1373](#)
 CREATE TRUSTED CONTEXT statement [1792](#)

server
 naming convention [83](#)
 remote [68](#)

SESSION TIME ZONE special register
 assigning a value [2168](#)

session variable
 built-in [329](#), [336](#)
 returning values [464](#)

session variable, built-in [329](#), [336](#)

session variables
 built-in [227](#)
 user-defined [227](#)

SESSION_USER [215](#)

SESSION_USER clause
 SET PATH statement [2164](#)

SESSION_USER special register [214](#)

SET assignment-statement
 description [2124](#)

SET assignment-statement statement
 example [2128](#)

SET CACHE clause
 ALTER TABLE statement [1264](#)

SET clause
 DELETE statement [1861](#)

SET clause of UPDATE statement [2187](#)

SET CONNECTION statement
 description [2122](#)
 example [2123](#)

SET CURRENT ACCELERATOR statement
 description [2129](#)
 example [2130](#)

SET CURRENT APPLICATION COMPATIBILITY statement
 description [2130](#)
 example [2132](#)

SET CURRENT APPLICATION ENCODING SCHEME
 statement
 description [2132](#)
 example [2133](#)

SET CURRENT DEBUG MODE statement
 description [2133](#)
 example [2134](#)

SET CURRENT DECFLOAT ROUNDING MODE statement
 description [2134](#)
 example [2136](#)

SET CURRENT DEGREE statement
 description [2136](#)
 example [2137](#)

SET CURRENT EXPLAIN MODE statement
 description [2137](#)
 example [2138](#)

SET CURRENT GET_ACCEL_ARCHIVE statement
 description [2138](#)

SET CURRENT LOCALE LC_CTYPE statement
 description [2139](#)
 example [2140](#)

SET CURRENT MAINTAINED TABLE TYPES FOR
 OPTIMIZATION statement
 description [2141](#)
 example [2142](#)

SET CURRENT OPTIMIZATION HINT statement
 description [2142](#)
 example [2143](#)

SET CURRENT PACKAGE PATH
 statement
 description [2143](#)
 example [2145](#)

SET CURRENT PACKAGESET statement

SET CURRENT PACKAGESET statement (*continued*)
 description [2146](#)
 example [2147](#)

SET CURRENT PRECISION statement
 description [2148](#)
 example [2148](#)

SET CURRENT QUERY ACCELERATION statement
 description [2148](#)

SET CURRENT QUERY ACCELERATION WAITFORDATA statement
 description [2150](#)

SET CURRENT REFRESH AGE statement
 description [2153](#)

SET CURRENT ROUTINE VERSION statement
 description [2154](#)
 example [2155](#)

SET CURRENT RULES statement
 description [2156](#)
 example [2156](#)

SET CURRENT SQLID statement
 description [2156](#)
 example [207](#), [2158](#)

SET CURRENT TEMPORAL BUSINESS_TIME statement
 description [2158](#)

SET CURRENT TEMPORAL SYSTEM_TIME statement
 description [2160](#)

SET CYCLE clause
 ALTER TABLE statement [1264](#)

SET ENCRYPTION PASSWORD statement [2161](#)

SET INCREMENT BY clause
 ALTER TABLE statement [1264](#)

SET MAXVALUE clause
 ALTER TABLE statement [1264](#)

SET MINVALUE clause
 ALTER TABLE statement [1264](#)

SET NO CYCLE clause
 ALTER TABLE statement [1264](#)

SET NO MAXVALUE clause
 ALTER TABLE statement [1264](#)

SET NO MINVALUE clause
 ALTER TABLE statement [1264](#)

SET NO ORDER clause
 ALTER TABLE statement [1264](#)

SET NULL delete rule
 ALTER TABLE statement [1271](#)
 CREATE TABLE statement [1684](#)

set operators [1061](#)

SET ORDER clause
 ALTER TABLE statement [1264](#)

SET PATH statement
 description [2163](#)
 example [2165](#)

SET QUERYNO clause of EXPLAIN statement [1919](#)

SET SCHEMA statement
 description [2166](#)

SET SESSION TIME_ZONE statement
 description [2168](#)
 example [2169](#)

SGCREATOR column of SYSVOLUMES catalog table [2733](#)

SGNAME column of SYSVOLUMES catalog table [2733](#)

SHARE
 option of LOCK TABLE statement [2017](#)

shift-in character
 convention [xxvii](#)

shift-in character (*continued*)
 LABEL statement [2016](#)
 not truncated by assignments [150](#)

shift-out character
 convention [xxvii](#)
 LABEL statement [2016](#)

short string column [103](#), [112](#)

shortcut keys
 keyboard [xxv](#)

SHRLEVEL
 column of SYSCOPY catalog table [2408](#)

SIGN function [570](#)

sign-on exit routine
 CURRENT SQLID special register [94](#), [207](#)

SIGNAL statement
 description [2169](#)
 example [2242](#), [2299](#)
 SQL procedure [2299](#)
 SQL routine [2242](#)

SIGNATURE column
 SYSVIEWS catalog table [2730](#)

SIMPLE CALL clause
 CREATE PROCEDURE (external) statement [1596](#)

SIMPLE CALL WITH NULLS clause
 CREATE PROCEDURE (external) statement [1596](#)

simple table spaces [50](#)

SIN function [570](#)

single logging [40](#)

single-byte character set (SBCS) [17](#)

single-row-fetch clause
 FETCH statement [1936](#)

SINH function [571](#)

SKCT (skeleton cursor table) [39](#)

skeleton cursor table (SKCT) [39](#)

skeleton package table (SKPT) [39](#)

SKIP LOCKED DATA clause
 DELETE statement [1863](#)
 SELECT INTO statement [2120](#)
 select-statement [1076](#)
 UPDATE statement [2190](#)

SKPT (skeleton package table) [39](#)

SMALLINT function [571](#)

SOAPHTTTPC and SOAPHTTTPV functions [573](#)

SOAPHTTTPNC and SOAPHTTTPNV functions [574](#)

SOME quantified predicate [300](#)

sort-key
 ORDER BY clause of subselect [1044](#)

SOUNDEX function [572](#)

SOURCE clause of CREATE FUNCTION statement [1504](#)

SOURCEDSN column
 SYSROUTINES_OPTS catalog table [2635](#)

SOURCESHEMA column
 SYSDATATYPES catalog table [2429](#)
 SYSROUTINES catalog table [2621](#)

SOURCESPECIFIC column of SYSROUTINES catalog table [2621](#)

SOURCETYPE column of SYSDATATYPES catalog table [2429](#)

SOURCETYPEID column
 DATATYPES catalog table [2429](#)
 SYSCOLUMNS catalog table [2381](#)
 SYSKEYTARGETS catalog table [2500](#)
 SYSKEYTARGETS_HIST catalog table [2505](#)
 SYSPARMS catalog table [2565](#)
 SYSSEQUENCES catalog table [2643](#)

SOURCETYPEID column (*continued*)
 SYSVARIABLES catalog table [2724](#)

space character [75](#)

SPACE column
 SYSINDEXES catalog table [2461](#)
 SYSINDEXPART catalog table [2474](#)
 SYSSTOGROUP catalog table [2655](#)
 SYSTABLEPART catalog table [2665](#)
 SYSTABLESPACE catalog table [2688](#)

SPACE column of SYSINDEXSPACESTATS catalog table [2482](#)

SPACE column of SYSTABLESPACESTATS catalog table [2699](#)

SPACE function [575](#)

SPACEF column
 SYSINDEXES catalog table [2461](#)
 SYSINDEXES_HIST catalog table [2472](#)
 SYSINDEXPART catalog table [2474](#)
 SYSINDEXPART_HIST catalog table [2480](#)
 SYSSTOGROUP catalog table [2655](#)
 SYSTABLEPART catalog table [2665](#)
 SYSTABLEPART_HIST catalog table [2675](#)
 SYSTABLES catalog table [2678](#)
 SYSTABLES_HIST catalog table [2707](#)
 SYSTABLESPACE catalog table [2688](#)

SPARSE column
 SYSINDEXES catalog table [2461](#)

SPARTKEYCOLNUM column
 SYSINDEXES catalog table [2461](#)

special character [75](#)

special register
 behavior in user-defined functions and stored procedures [215](#)
 CURRENT ACCELERATOR [184](#)
 CURRENT APPLICATION COMPATIBILITY [184](#)
 CURRENT APPLICATION ENCODING SCHEME [185](#)
 CURRENT CLIENT_ACCTNG [186](#)
 CURRENT CLIENT_APPLNAME [187](#)
 CURRENT CLIENT_CORR_TOKEN [189](#)
 CURRENT CLIENT_USERID [189](#)
 CURRENT CLIENT_WRKSTNNAME [190](#)
 CURRENT DATE [192](#)
 CURRENT DEBUG MODE [192](#)
 CURRENT DECFLOAT ROUNDING MODE [193](#)
 CURRENT DEGREE [194](#)
 CURRENT EXPLAIN MODE [194](#)
 CURRENT GET_ACCEL_ARCHIVE [195](#)
 CURRENT LOCALE LC_CTYPE [196](#)
 CURRENT MAINTAINED TABLE TYPES FOR OPTIMIZATION [197](#)
 CURRENT MEMBER [198](#)
 CURRENT OPTIMIZATION HINT [198](#)
 CURRENT PACKAGE PATH [199](#)
 CURRENT PACKAGESET [199](#)
 CURRENT PATH [200](#)
 CURRENT PRECISION [201](#)
 CURRENT QUERY ACCELERATION [202](#)
 CURRENT QUERY ACCELERATION WAITFORDATA [203](#)
 CURRENT REFRESH AGE [204](#)
 CURRENT ROUTINE VERSION [204](#)
 CURRENT RULES [205](#)
 CURRENT SCHEMA [206](#)
 CURRENT SERVER [207](#)
 CURRENT SQLID [207](#)
 CURRENT TEMPORAL BUSINESS_TIME [208](#)
 CURRENT TEMPORAL SYSTEM_TIME [210](#)

special register (*continued*)
 CURRENT TIME [211](#)
 CURRENT TIMESTAMP [212](#)
 CURRENT TIMEZONE [213](#), [214](#)
 CURRENT_DATE [192](#)
 CURRENT_TIME [211](#)
 CURRENT_TIMESTAMP [212](#)
 description [177](#)
 ENCRYPTION PASSWORD [213](#)
 SESSION_USER [214](#)
 USER [214](#)
 values in trigger [1763](#), [1782](#)

SPECIAL REGS column
 SYSROUTINES catalog table [2621](#)

specific
 naming convention [83](#)

SPECIFIC clause
 CREATE FUNCTION (inlined SQL scalar) statement [1494](#)
 CREATE FUNCTION statement [1435](#), [1460](#), [1479](#), [1504](#)

SPECIFIC FUNCTION clause of ALTER FUNCTION statement [1102](#)

specific name
 unqualified name [86](#)

SPECIFIC procedure-name clause
 CREATE PROCEDURE (external) statement [1588](#)

specifications
 XMLCAST [277](#)

SPECIFICNAME column
 SYSPARMS catalog table [2565](#)
 SYSROUTINEAUTH catalog table [2619](#)
 SYSROUTINES catalog table [2621](#)

SPLIT_ROWS column
 SYSTABLES catalog table [2678](#)

SPT01 table space [39](#)

SQD_STMT_ID
 column of SYSQRY catalog table [2444](#)

SQL
 statements [1079](#)

SQL (structured query language)
 executing [1](#)

SQL (Structured Query Language)
 assignment operation [143](#)
 Call Level Interface (CLI) [3](#)
 character [75](#)
 comparison operation [143](#)
 constants [170](#)
 data types
 binary strings [116](#)
 casting [130](#)
 character strings [102](#)
 datetime [118](#)
 description [98](#)
 graphic strings [112](#)
 LOBs (large objects) [116](#)
 numbers [99](#)
 numeric implicit cast [141](#)
 promotion [129](#)
 results of an operation [166](#)
 row ID [124](#)
 string implicit cast [142](#)
 XML values [125](#)
 deferred embedded [2](#)
 delimited identifier [77](#)
 dynamic

SQL (Structured Query Language) *(continued)*

- dynamic *(continued)*
 - statements allowed [2269](#)
- identifier [77](#)
- JDBC [4](#)
- keywords, reserved [2258](#)
- limits [2247](#)
- naming conventions [79](#)
- Open Database Connectivity (ODBC) [3](#)
- ordinary identifier [75](#)
- rules [205](#)
- schema names, reserved [2257](#)
- SQLJ [4](#)
- standard [326](#)
- standards [xxviii](#)
- static [1](#)
- token [75](#)
- value [98](#)
- variable names [79](#)
- SQL comments [1092](#)
- SQL condition
 - naming convention [84](#)
- SQL condition names [2209](#), [2210](#)
- SQL control statement
 - assignment statement [2217](#), [2281](#)
 - CALL statement [2218](#), [2282](#)
 - CASE statement [2219](#), [2284](#)
 - compound statement [2221](#), [2286](#)
 - CONTINUE handler [2221](#), [2286](#)
 - EXIT handler [2221](#), [2286](#)
 - FOR statement [2229](#)
 - GET DIAGNOSTICS statement [2230](#), [2290](#)
 - GOTO statement [2231](#), [2290](#)
 - handler [2221](#), [2286](#)
 - handling errors [2221](#), [2286](#)
 - IF statement [2232](#), [2292](#)
 - ITERATE statement [2233](#), [2293](#)
 - LEAVE statement [2234](#), [2293](#)
 - LOOP statement [2236](#), [2294](#)
 - order of statements [2221](#), [2286](#)
 - REPEAT statement [2237](#), [2295](#)
 - RESIGNAL statement [2238](#), [2296](#)
 - RETURN statement [2240](#), [2298](#)
 - SIGNAL statement [2242](#), [2299](#)
 - WHILE statement [2245](#), [2302](#)
- SQL cursor names [2210](#)
- SQL identifier
 - delimited [77](#)
 - ordinary [77](#)
- SQL label
 - naming convention [84](#)
- SQL parameter
 - naming convention [84](#)
- SQL parameters [2208](#)
- SQL path [85](#), [239](#)
- SQL PATH clause
 - ALTER PROCEDURE (SQL - native) statement [1209](#)
 - CREATE FUNCTION statement [1128](#), [1442](#)
 - CREATE PROCEDURE (SQL - native) statement [1624](#)
 - CREATE TRIGGER statement [1354](#), [1752](#)
- SQL procedure
 - new line control character [75](#)
- SQL scalar statements
 - ALTER FUNCTION [1113](#)

SQL statements

- ALLOCATE CURSOR [1093](#)
- ALTER DATABASE [1095](#)
- ALTER FUNCTION [1097](#)
- ALTER FUNCTION (SQL table) [1150](#)
- ALTER INDEX [1157](#)
- ALTER MASK [1174](#)
- ALTER PERMISSION [1177](#)
- ALTER PROCEDURE (external) [1180](#)
- ALTER PROCEDURE (SQL - external) [1189](#)
- ALTER PROCEDURE (SQL - native) statement [1194](#)
- ALTER SEQUENCE [1224](#)
- ALTER STOGROUP [1228](#)
- ALTER TABLE [1232](#)
- ALTER TABLESPACE [1321](#)
- ALTER TRIGGER [1342](#), [1365](#)
- ALTER TRUSTED CONTEXT [1368](#)
- ALTER VIEW [1378](#)
- ASSOCIATE LOCATORS [1380](#)
- BEGIN DECLARE SECTION [1383](#)
- CALL [1384](#)
- catalog table restrictions [2739](#)
- CLOSE [1395](#)
- COMMENT [1396](#)
- COMMIT [1406](#)
- CONNECT [1409](#)
- CONTINUE [2204](#)
- CREATE ALIAS [1415](#)
- CREATE AUXILIARY TABLE [1418](#)
- CREATE DATABASE [1421](#)
- CREATE FUNCTION [1424](#)
- CREATE FUNCTION (compiled SQL scalar) [1428](#)
- CREATE FUNCTION (external scalar) [1453](#)
- CREATE FUNCTION (external table) [1472](#)
- CREATE FUNCTION (inlined SQL scalar) [1489](#)
- CREATE FUNCTION (sourced) [1498](#)
- CREATE FUNCTION (SQL table) [1510](#)
- CREATE GLOBAL TEMPORARY TABLE [1518](#)
- CREATE INDEX [1524](#)
- CREATE MASK [1562](#)
- CREATE PERMISSION [1571](#)
- CREATE PROCEDURE [1578](#)
- CREATE PROCEDURE (external) [1580](#)
- CREATE PROCEDURE (SQL - external) [1597](#)
- CREATE PROCEDURE (SQL - native) [1607](#)
- CREATE ROLE [1637](#)
- CREATE SEQUENCE [1638](#)
- CREATE STOGROUP [1645](#)
- CREATE SYNONYM [1649](#)
- CREATE TABLE [1650](#)
- CREATE TABLESPACE [1718](#)
- CREATE TRIGGER [1740](#), [1769](#)
- CREATE TRUSTED CONTEXT [1787](#)
- CREATE TYPE [1795](#)
- CREATE TYPE (array) [1795](#)
- CREATE TYPE (distinct) [1801](#)
- CREATE VARIABLE [1808](#)
- CREATE VIEW [1812](#)
- DECLARE CURSOR
 - description [1819](#)
 - example [1819](#)
- DECLARE GLOBAL TEMPORARY TABLE [1830](#)
- DECLARE STATEMENT [1844](#)
- DECLARE TABLE [1845](#)

SQL statements (*continued*)

DECLARE VARIABLE [1850](#)
DELETE
 description [1853](#)
 example [1868](#)
DESCRIBE [1869](#)
DESCRIBE CURSOR [1869](#)
DESCRIBE INPUT [1871](#)
DESCRIBE OUTPUT [1873](#)
DESCRIBE PROCEDURE [1879](#)
DESCRIBE TABLE [1881](#)
DROP [1886](#)
END DECLARE SECTION [1907](#)
EXCHANGE [1908](#)
EXECUTE [1909](#)
EXECUTE IMMEDIATE [1914](#)
EXPLAIN
 description [1917](#)
 example [1923](#)
FETCH
 description [1924](#)
 example [1947](#)
FOR [1919](#)
FREE LOCATOR [1949](#)
GET DIAGNOSTICS [1949](#)
GRANT [1963](#)
HOLD LOCATOR [1994](#)
INCLUDE
 description [1995](#)
 example [1996](#)
 SQLCA [2308](#)
 SQLDA [2326](#)
INSERT
 description [1996](#)
 example [2011](#)
invocation [1086](#)
LABEL [2015](#)
LOCALE LC_CTYPE [2139](#)
LOCK TABLE [2017](#)
MERGE
 description [2019](#)
 examples [2034](#)
OPEN
 description [2037](#)
 example [2041](#)
PREPARE [2042](#)
REFRESH TABLE [2062](#)
RELEASE (connection) [2063](#)
RELEASE SAVEPOINT [2065](#)
remote execution
 description [96](#)
RENAME [2066](#)
REVOKE [2070](#)
ROLLBACK [2110](#)
SAVEPOINT [2113](#)
SELECT
 unpacked-row [1015](#)
SELECT INTO [2117](#)
SET assignment-statement [2124](#)
SET CONNECTION [2122](#)
SET CURRENT ACCELERATOR [2129](#)
SET CURRENT APPLICATION COMPATIBILITY [2130](#)
SET CURRENT APPLICATION ENCODING SCHEME [2132](#)
SET CURRENT DEBUG MODE [2133](#)

SQL statements (*continued*)

SET CURRENT DECFLOAT ROUNDING MODE [2134](#)
SET CURRENT DEGREE [2136](#)
SET CURRENT EXPLAIN MODE [2137](#)
SET CURRENT GET_ACCEL_ARCHIVE [2138](#)
SET CURRENT MAINTAINED TABLE TYPES FOR OPTIMIZATION [2141](#)
SET CURRENT OPTIMIZATION HINT [2142](#)
SET CURRENT PACKAGE PATH
 example [2145](#)
SET CURRENT PRÉCISION [2148](#)
SET CURRENT QUERY ACCELERATION [2148](#)
SET CURRENT QUERY ACCELERATION WAITFORDATA [2150](#)
SET CURRENT REFRESH AGE [2153](#)
SET CURRENT ROUTINE VERSION [2154](#)
SET CURRENT RULES [2156](#)
SET CURRENT SQLID [2156](#)
SET CURRENT TEMPORAL BUSINESS_TIME [2158](#)
SET CURRENT TEMPORAL SYSTEM_TIME [2160](#)
SET ENCRYPTION PASSWORD [2161](#)
SET PATH [2163](#)
SET SCHEMA [2166](#)
SET SESSION TIME ZONE [2168](#)
SIGNAL [2169](#)
TRANSFER OWNERSHIP [2172](#)
TRUNCATE [2175](#)
UPDATE
 description [2178](#)
 example [2196](#)
VALUES [2199](#)
VALUES INTO [2200](#)
WHENEVER [2204](#)
SQL syntax
 regression functions [374](#)
SQL variable
 naming convention [84](#)
SQL variables [2208](#)
SQL_DATA_ACCESS column of SYSROUTINES catalog table [2621](#)
SQL_STRING_DELIMITER column
 SYSENVIRONMENT catalog table [2452](#)
SQL_STRING_DELIMITER session variable [336](#)
SQL-routine-body
 ALTER PROCEDURE (SQL - native) statement [1216](#)
 CREATE PROCEDURE (SQL - native) statement [1631](#)
SQL-routine-body clause
 CREATE FUNCTION statement [1134](#), [1448](#)
SQL/OLB [4](#)
SQLADM privilege
 GRANT statement [1985](#)
 REVOKE statement [2098](#)
SQLCA
 REXX [2310](#)
SQLCA (SQL communication area)
 contents [2303](#)
 entry changed by UPDATE [2190](#)
 INCLUDE statement [1995](#)
SQLCABC field of SQLCA [2303](#)
SQLCAID field of SQLCA [2303](#)
SQLCODE
 +100 [1092](#), [2003](#), [2037](#), [2117](#), [2204](#)
 description [1092](#)
 field of SQLCA [2303](#)

SQLD field of SQLDA [1876](#), [1884](#), [2314](#)
 SQLDA
 header [2314](#)
 REXX [2329](#)
 unrecognized data types [2325](#)
 SQLDA (SQL descriptor area)
 clause of INCLUDE statement [1995](#)
 contents [2313](#)
 SQLDABC field of SQLDA [1876](#), [1884](#), [2314](#)
 SQLDAID field of SQLDA [1875](#), [1884](#), [2314](#)
 SQLDATA field of SQLDA [1876](#), [1885](#), [2317](#)
 SQLDATAL field of SQLDA [2320](#)
 SQLDATALEN field of SQLDA [2320](#)
 SQLDATATYPE field of SQLDA [1877](#), [1886](#)
 SQLDATATYPE-NAME field of SQLDA [2320](#)
 SQLERRD(n) field of SQLCA [2303](#)
 SQLERRMC field of SQLCA [2303](#)
 SQLERRML field of SQLCA [2303](#)
 SQLERROR
 clause of WHENEVER statement [2204](#)
 column of SYSPACKAGE catalog table [2519](#)
 SQLERRP field of SQLCA [2303](#)
 SQLIND field of SQLDA [1876](#), [1885](#), [2317](#)
 SQLJ 4
 SQLJ.ALTER_JAVA_PATH stored procedure [988](#)
 SQLJ.DB2_INSTALL_JAR stored procedure [991](#)
 SQLJ.DB2_REPLACE_JAR stored procedure [992](#)
 SQLJ.INSTALL_JAR stored procedure [994](#)
 SQLJ.REMOVE_JAR stored procedure [995](#)
 SQLJ.REPLACE_JAR stored procedure [996](#)
 SQLLEN field of SQLDA [1876](#), [1885](#), [2317](#)
 SQLLONGL field of SQLDA [2320](#)
 SQLLONGLEN field of SQLDA [1877](#), [1885](#), [2320](#)
 SQLN field of SQLDA
 description [1873](#), [1882](#), [2314](#)
 SQLNAME field of SQLDA [1876](#), [1885](#), [2317](#)
 SQLPL column
 SYSTRIGGERS catalog table [2712](#)
 SQLRULES
 column of SYSPLAN catalog table [2575](#)
 SQLSTATE
 '02000' [2003](#), [2037](#), [2117](#), [2204](#)
 description [1091](#)
 field of SQLCA [2303](#)
 signaling [2169](#)
 SQLTNAME field of SQLDA [2320](#)
 SQLTYPE field of SQLDA
 description [2317](#)
 values [1876](#), [1885](#), [2322](#)
 SQLVAR
 base [1876](#), [1884](#)
 extended [1876](#), [1884](#)
 SQLVAR field of SQLDA [1876](#), [1884](#)
 SQLWARN6 field of SQLCA [260](#)
 SQLWARNING clause
 WHENEVER statement [2204](#)
 SQLWARNn field of SQLCA [2303](#)
 SQRT function [575](#)
 SQTQ column
 SYSINDEXPART catalog table [2474](#)
 SYSTABLEPART catalog table [2665](#)
 SSID column
 SYSINDEXCONTROL catalog table [2460](#)
 SSID session variable [336](#)
 STANDARD CALL clause
 CREATE PROCEDURE (external) statement [1596](#)
 STANDARD_SQL session variable [336](#)
 standard, SQL (ANSI/ISO)
 description xxviii
 SET CONNECTION statement [2122](#)
 SQL-style comments [75](#)
 STDSQL precompiler option [326](#)
 START column of SYSSEQUENCES catalog table [2643](#)
 START WITH clause
 CREATE SEQUENCE statement [1640](#)
 START_RBA column of SYSCOPY catalog table [2408](#)
 START_RBA_EX column
 SYSCOPY catalog table [2408](#)
 STARTDB privilege
 GRANT statement [1969](#)
 REVOKE statement [2079](#)
 STARTDBAUTH column of SYSDBAUTH catalog table [2432](#)
 state
 application process [71](#), [72](#)
 SQL connection [70](#)
 statement
 naming convention [84](#)
 STATEMENT clause of DECLARE STATEMENT statement [1844](#)
 STATEMENT column
 SYSTRIGGERS catalog table [2712](#)
 statement table
 EXPLAIN statement [1917](#)
 statements
 SQL [1079](#)
 STATIC clause
 DECLARE CURSOR statement [1822](#)
 STATIC DISPATCH clause
 ALTER FUNCTION statement [1111](#), [1124](#), [1148](#)
 CREATE FUNCTION (inlined SQL scalar) statement [1496](#)
 CREATE FUNCTION statement [1437](#), [1470](#), [1487](#), [1516](#)
 static SQL
 description [1086](#)
 invocation of SELECT statement [1089](#)
 statistics
 real-time
 stored procedure [848](#)
 STATS privilege
 GRANT statement [1969](#)
 REVOKE statement [2079](#)
 STATS_FORMAT column
 SYSCOLSTATS catalog table [2379](#)
 SYSCOLUMNS catalog table [2381](#)
 SYSCOLUMNS_HIST catalog table [2395](#)
 SYSKEYTARGETS catalog table [2500](#)
 SYSKEYTARGETS_HIST catalog table [2505](#)
 SYSKEYTARGETSTATS catalog table [2503](#)
 STATS_AUTH column of SYSDBAUTH catalog table [2432](#)
 STATSDELETES column
 SYSINDEXSPACESTATS catalog table [2482](#)
 SYSTABLESPACESTATS catalog table [2699](#)
 STATSINSERTS column
 SYSINDEXSPACESTATS catalog table [2482](#)
 SYSTABLESPACESTATS catalog table [2699](#)
 STATSLASTTIME column
 SYSINDEXSPACESTATS catalog table [2482](#)
 SYSTABLESPACESTATS catalog table [2699](#)
 STATSMASSDELETE column

STATSMASDELETE column (*continued*)
 SYSTABLESPACESTATS catalog table [2699](#)
 STATSMASDELETES column
 SYSINDEXSPACESTATS catalog table [2482](#)
 STATSTIME column
 SYSCOLDIST catalog table [2373](#)
 SYSCOLDIST_HIST catalog table [2377](#)
 SYSCOLDISTSTATS catalog table [2375](#)
 SYSCOLSTATS catalog table [2379](#)
 SYSCOLUMNS catalog table [2381](#)
 SYSCOLUMNS_HIST catalog table [2395](#)
 SYSINDEXES catalog table [2461](#)
 SYSINDEXES_HIST catalog table [2472](#)
 SYSINDEXPART catalog table [2474](#)
 SYSINDEXPART_HIST catalog table [2480](#)
 SYSINDEXSTATS catalog table [2490](#)
 SYSINDEXSTATS_HIST catalog table [2492](#)
 SYSKEYTARGETS catalog table [2500](#)
 SYSKEYTARGETS_HIST catalog table [2505](#)
 SYSKEYTARGETSTATS catalog table [2503](#)
 SYSKEYTGTDIST catalog table [2509](#)
 SYSKEYTGTDIST_HIST catalog table [2513](#)
 SYSKEYTGTDISTSTATS catalog table [2511](#)
 SYSLOBSTATS catalog table [2516](#)
 SYSLOBSTATS_HIST catalog table [2516](#)
 SYSSTOGROUP catalog table [2655](#)
 SYSTABLEPART catalog table [2665](#)
 SYSTABLEPART_HIST catalog table [2675](#)
 SYSTABLES catalog table [2678](#)
 SYSTABLES_HIST catalog table [2707](#)
 SYSTABLESPACE catalog table [2688](#)
 SYSTABSTATS catalog table [2710](#)
 SYSTABSTATS_HIST catalog table [2711](#)
 STATSUPDATES column
 SYSTABLESPACESTATS catalog table [2699](#)
 STATUS column
 SYSIBM.XSROBJECTCOMPONENTS table [2783](#)
 SYSIBM.XSROBJECTS table [2782](#)
 SYSINDEXES catalog table [2461](#)
 SYSPACKSTMT catalog table [2558](#)
 SYSSTMT catalog table [2651](#)
 SYSTABLES catalog table [2678](#)
 SYSTABLESPACE catalog table [2688](#)
 STAY RESIDENT clause
 ALTER FUNCTION statement [1110](#)
 ALTER PROCEDURE (external) statement [1186](#)
 ALTER PROCEDURE (SQL - external) statement [1192](#)
 CREATE FUNCTION statement [1468](#), [1486](#)
 CREATE PROCEDURE (external) statement [1594](#)
 CREATE PROCEDURE (SQL - external) statement [1604](#)
 STAYRESIDENT column
 SYSROUTINES catalog table [2621](#)
 STBLGRP
 column of SYSDYNQRY catalog table [2444](#)
 STD SQL LANGUAGE field of panel DSNTIP4 [326](#)
 STDDEV function [376](#)
 STDDEV_POP
 aggregate function [376](#)
 STDDEV_SAMP
 aggregate function [377](#)
 STDSQL option
 precompiler [326](#)
 STGROUP column of SYSDATABASE catalog table [2427](#)
 STMT column of SYSPACKSTMT catalog table [2558](#)
 STMTCACHE clause of EXPLAIN statement [1920](#)
 STMTHASH
 column of SYSDYNQRYDEP catalog table [2446](#)
 STMTNO column
 SYSPACKSTMT catalog table [2558](#)
 SYSSTMT catalog table [2651](#)
 STMTNOI column
 SYSPACKSTMT catalog table [2558](#)
 SYSSTMT catalog table [2651](#)
 STMTTEXT
 column of SYSDYNQRY catalog table [2444](#)
 STNAME column of SYSTABAUTH catalog table [2659](#)
 stogroup
 naming convention [84](#)
 STOGROUP
 clause of ALTER INDEX statement [1163](#), [1165](#)
 clause of ALTER STOGROUP statement [1228](#)
 clause of CREATE DATABASE statement [1423](#)
 clause of CREATE INDEX statement [1538](#), [1540](#)
 clause of CREATE LOB TABLESPACE statement [1559](#)
 clause of CREATE TABLESPACE statement [1733](#)
 STOGROUP clause
 ALTER DATABASE statement [1095](#)
 ALTER TABLESPACE statement [1332](#)
 DROP statement [1896](#)
 STOGROUP privilege
 GRANT statement [1993](#)
 REVOKE statement [2109](#)
 STOP AFTER SYSTEM DEFAULT FAILURES clause
 ALTER FUNCTION statement [1110](#)
 ALTER PROCEDURE (external) statement [1188](#)
 ALTER PROCEDURE (SQL - external) statement [1193](#)
 CREATE FUNCTION statement [1469](#), [1487](#)
 CREATE PROCEDURE (external) statement [1594](#)
 CREATE PROCEDURE (SQL - external) statement [1606](#)
 STOPALL privilege
 GRANT statement [1986](#)
 REVOKE statement [2099](#)
 STOPALLAUTH column of SYSUSERAUTH catalog table [2715](#)
 STOPAUTH column of SYSDBAUTH catalog table [2432](#)
 STOPDB privilege
 GRANT statement [1969](#)
 REVOKE statement [2079](#)
 storage group, DB2
 altering [1228](#)
 creating [1645](#)
 dropping [1896](#)
 storage groups [54](#)
 storage structures
 index spaces [48](#)
 table spaces [48](#)
 STORCLAS clause
 CREATE STOGROUP statement [1230](#), [1647](#)
 STORCLAS column
 SYSSTOGROUP catalog table [2655](#)
 stored procedure
 altering
 ALTER PROCEDURE (external) statement [1180](#)
 with ALTER PROCEDURE (SQL - external) statement [1189](#)
 with ALTER PROCEDURE (SQL - native) statement [1194](#)
 CALL statement [1384](#)
 creating

stored procedure (*continued*)

creating (*continued*)

CREATE PROCEDURE (external) statement [1580](#)

with CREATE PROCEDURE (SQL - external)

statement [1597](#)

with CREATE PROCEDURE (SQL - native) statement [1607](#)

CURRENT PACKAGESET special register [2147](#)

dropping [1895](#)

DSNUTILS [895](#)

DSNUTILU [906](#)

DSNUTILV [910](#)

invoking [1384](#)

name, unqualified [86](#)

naming convention [82](#)

privileges

granting [1970](#)

revoking [2081](#)

statements allowed [2275](#)

unqualified name [86](#)

WLM_REFRESH [997](#)

stored procedures

ADMIN_COMMAND_Db2 [699](#)

ADMIN_COMMAND_DSN [712](#)

ADMIN_COMMAND_MVS [714](#)

ADMIN_COMMAND_UNIX [725](#)

ADMIN_DB_BROWSE [729](#)

ADMIN_DB_DELETE [732](#)

ADMIN_DS_LIST [735](#)

ADMIN_DS_RENAME [741](#)

ADMIN_DS_SEARCH [744](#)

ADMIN_DS_WRITE [747](#)

ADMIN_INFO_HOST [760](#)

ADMIN_INFO_SMS [766](#)

ADMIN_INFO_SQL [771](#)

ADMIN_INFO_SSID [770](#)

ADMIN_INFO_SYSLOG [781](#)

ADMIN_INFO_SYSPARM [784](#)

ADMIN_JOB_CANCEL [788](#)

ADMIN_JOB_FETCH [791](#)

ADMIN_JOB_QUERY [794](#)

ADMIN_JOB_SUBMIT [798](#)

ADMIN_TASK_ADD [802](#)

ADMIN_TASK_CANCEL [808](#)

ADMIN_TASK_REMOVE [809](#)

ADMIN_TASK_UPDATE [811](#)

ADMIN_UPDATE_SYSPARM [814](#)

ADMIN_UTL_EXECUTE [822](#)

ADMIN_UTL_MODIFY [830](#)

ADMIN_UTL_MONITOR [824](#)

ADMIN_UTL_SCHEDULE [832](#)

ADMIN_UTL_SORT [841](#)

Db2-supplied [699](#)

DSNACCOX [848](#)

DSNACICS [880](#)

DSNAIMS [885](#)

DSNAIMS2 [889](#)

DSNLEUSR [893](#)

external SQL procedures [35](#)

external stored procedures [35](#)

GET_CONFIG [923](#)

GET_MESSAGE [942](#)

GET_SYSTEM_INFO [949](#)

inheriting special registers [215](#)

stored procedures (*continued*)

native SQL procedures [35](#)

real-time statistics [848](#)

STORENAME column

SYSTABLESPACE catalog table [2688](#)

STORES clause of CREATE AUXILIARY TABLE statement [1419](#)

STORNAME column

SYSINDEXES catalog table [2461](#)

SYSINDEXPART catalog table [2474](#)

SYSTABLEPART catalog table [2665](#)

STORNAME column

SYSINDEXES catalog table [2461](#)

SYSINDEXPART catalog table [2474](#)

SYSTABLEPART catalog table [2665](#)

SYSTABLESPACE catalog table [2688](#)

STOSPACE privilege

GRANT statement [1986](#)

REVOKE statement [2099](#)

STOSPACEAUTH column of SYSUSERAUTH catalog table [2715](#)

string

binary [116](#)

CCSID [63](#)

character [102](#)

comparison [157](#)

conversion [59](#)

datetime values [120](#)

delimiter

COBOL [324](#)

controlling representation [324](#)

SQL [324](#)

description [59](#)

encoding scheme [63](#)

fixed-length

description [103](#), [112](#)

graphic [112](#)

long column

description [112](#)

limitations [1012](#)

numbers [101](#)

short [103](#), [112](#)

varying-length

description [103](#), [112](#)

string clause

CREATE PROCEDURE (external) statement [1589](#)

STRING column

SYSXMLSTRINGS catalog table [2735](#)

string comparisons [157](#)

string data types

encoding schemes [17](#)

string delimiter precompiler option [324](#)

string unit [106](#)

STRING_DELIMITER column

SYSENVIRONMENT catalog table [2452](#)

STRINGID column

SYSXMLSTRINGS catalog table [2735](#)

STRIP function [565](#), [576](#)

STRLEFT function [576](#)

strong typing [126](#)

STRPOS function [577](#)

STRRIGHT function [577](#)

structured query language (SQL)

executing

structured query language (SQL) (*continued*)
 executing (*continued*)
 from a workstation [2](#)
 interactive SQL [2](#)
 QMF for Workstation [4](#)
 STYPE column of SYSCOPY catalog table [2408](#)
 SUBBYTE column of SYSSTRINGS catalog table [2656](#)
 subquery
 description [222](#)
 HAVING clause [1043](#)
 ORDER BY clause [1043](#)
 WHERE clause [1036](#)
 subselect
 CREATE VIEW statement [1009](#)
 description [1009](#)
 examples [1048](#)
 INSERT statement [1009](#)
 subselect query
 cube
 examples [1054](#)
 grouping sets
 examples [1054](#)
 joins
 examples [1054](#)
 rollup
 examples [1054](#)
 substitution character [59](#)
 SUBSTR function [577](#)
 SUBSTRING function [579](#)
 SUBTYPE column
 SYSDATATYPES catalog table [2429](#)
 SYSKEYTARGETS catalog table [2500](#)
 SYSPARMS catalog table [2565](#)
 SUM function [378](#)
 synonym
 defining [1649](#)
 description [89](#)
 dropping [1896](#)
 naming convention [84](#)
 qualifying a column name [220](#)
 SYNONYM clause
 CREATE SYNONYM statement [1649](#)
 DROP statement [1896](#)
 syntax diagram
 DSNUTILS stored procedure [899](#)
 DSNUTILU stored procedure [908](#)
 DSNUTILV stored procedure [911](#)
 how to read [xxvi](#)
 SYS_END column
 SYSROLES catalog table [2618](#), [2722](#)
 SYS_START column
 SYSROLES catalog table [2618](#), [2722](#)
 SYSADM authority
 GRANT statement [1986](#)
 REVOKE statement [2099](#)
 SYSADMAUTH column of SYSUSERAUTH catalog table [2715](#)
 SYSCTRL authority
 GRANT statement [1986](#)
 REVOKE statement [2099](#)
 SYSTRLAUTH column of SYSUSERAUTH catalog table [2715](#)
 SYSENTRIES column
 SYSPACKAGE catalog table [2519](#)
 SYSPLAN catalog table [2575](#)
 SYSIBM.DBDR [2771](#)
 SYSIBM.SCTR [2771](#)
 SYSIBM.SPTR [2771](#)
 SYSIBM.SYSDBD_DATA [2771](#)
 SYSIBM.SYSINDEXCLEANUP
 catalog table [2458](#)
 SYSIBM.SYSLGRNX [2772](#)
 SYSIBM.SYSQUERYPREDICATE
 catalog table [2606](#)
 columns [2606](#)
 SYSIBM.SYSQUERYSEL
 catalog table [2611](#)
 columns [2611](#)
 SYSIBM.SYSSPTSEC_DATA [2772](#)
 SYSIBM.SYSSPTSEC_EXPL [2772](#)
 SYSIBM.SYSSTATFEEDBACK
 catalog table [2649](#)
 SYSIBM.SYSUTIL [2773](#)
 SYSIBM.SYSUTILX [2776](#)
 SYSLEVELUPDATES
 catalog table [2515](#)
 SYSLGRNX directory table
 table space [39](#)
 SYSMODENAME column of LUNAMES catalog table [2354](#)
 SYSOPR authority
 GRANT statement [1986](#)
 REVOKE statement [2099](#)
 SYSOPRAUTH column of SYSUSERAUTH catalog table [2715](#)
 SYSSESESSION
 catalog table [2647](#)
 SYSSESESSION_EX
 catalog table [2648](#)
 SYSSESESSION_STATUS
 catalog table [2648](#)
 SYSTEM AUTHID clause
 ALTER TRUSTED CONTEXT statement [1370](#)
 SYSTEM column
 SYSPKSYSTEM catalog table [2574](#)
 SYSPLSYSTEM catalog table [2586](#)
 system objects [38](#)
 SYSTEM PATH clause
 SET PATH statement [2164](#)
 system schemas [6](#)
 system structures
 active logs [40](#)
 archive logs [40](#)
 bootstrap data set (BSDS) [40](#)
 buffer pools [41](#)
 catalog tables [38](#)
 catalogs [38](#)
 SYSTEM_ASCII_CCSID session variable [336](#)
 SYSTEM_EBCDIC_CCSID session variable [336](#)
 SYSTEM_NAME session variable [336](#)
 SYSTEM_TIME SENSITIVE clause
 CREATE TRIGGER statement [1357](#), [1755](#)
 SYSTEM_UNICODE_CCSID session variable [336](#)
 system, limits [2247](#)
 SYSTEMAUTHID column
 SYSCONTEXT catalog table [2401](#)
 SYSUTILX directory table space [39](#)

T

table
 altering

table (*continued*)

- altering (*continued*)
 - ALTER TABLE statement [1232](#)
- creating
 - CREATE AUXILIARY TABLE statement [1418](#)
 - CREATE GLOBAL TEMPORARY TABLE statement [1518](#)
 - CREATE TABLE statement [1650](#)
 - CREATE VARIABLE statement [1808](#)
 - DECLARE GLOBAL TEMPORARY TABLE statement [1830](#)
- designator [221](#)
- dropping
 - DROP statement [1896](#)
- joining [1034](#)
- naming convention [84](#)
- privileges
 - revoking [2101](#)
- renaming with RENAME statement [2066](#)
- result table [2039](#)
- temporary copy [2039](#)
- Table
 - expressions, common [1069](#)
 - expressions, nested [1069](#)
- TABLE
 - clause of DECLARE TABLE statement [1845](#)
 - column of SYSPARMS catalog table [2565](#)
- table check constraint
 - defining
 - CREATE TABLE statement [1685](#)
 - deleting rows [1864](#)
 - inserting rows [2005](#)
 - updating rows [2191](#)
- TABLE clause
 - COMMENT statement [1404](#)
 - DROP statement [1896](#)
- table function reference [1021](#)
- TABLE LIKE clause
 - CREATE FUNCTION statement [1458](#), [1478](#), [1503](#)
 - CREATE PROCEDURE (external) statement [1587](#)
 - CREATE PROCEDURE (SQL - external) statement [1602](#)
 - CREATE PROCEDURE (SQL - native) statement [1617](#)
- table locator variable [1020](#)
- table name
 - qualifying a column name [220](#)
 - unqualified [86](#)
- table space
 - accelerators table [2931](#)
 - altering with ALTER TABLESPACE statement [1321](#)
 - creating
 - CREATE TABLESPACE statement [1718](#)
 - implicitly [1693](#)
 - directory table [2770](#)
 - dropping [1898](#)
 - naming convention [84](#)
 - program authorization table [2939](#)
 - XML schema repository table [2779](#)
- table spaces
 - large object [50](#)
 - partitioned [50](#)
 - segmented [50](#)
 - simple [50](#)
 - universal [50](#)
 - XML [50](#)
- TABLE_COLNO column of SYSPARMS catalog table [2565](#)
- TABLE_LOCATION function [2960](#)
- TABLE_NAME function [2961](#)
- TABLE_SCHEMA function [2962](#)
- table-name clause
 - EXCHANGE statement [1908](#)
- TABLE ←
 - clause of LABEL statement [2016](#)
- tables
 - column definitions
 - choosing a data type [16](#)
 - components [15](#)
 - dependent [12](#)
 - DSNPROGAUTH [2939](#)
 - inserting rows
 - check constraints [27](#)
 - overview [7](#)
 - self-referencing [12](#)
 - supplied by Db2
 - DSN_COLDIST_TABLE [2809](#)
 - DSN_DETCOST_TABLE [2817](#)
 - DSN_FILTER_TABLE [2827](#)
 - DSN_FUNCTION_TABLE [2832](#)
 - DSN_KEYTGTDIST_TABLE [2837](#)
 - DSN_PGRANGE_TABLE [2844](#)
 - DSN_PGROUPTABLE [2848](#)
 - DSN_PREDICAT_TABLE [2855](#)
 - PLAN_TABLE [2787](#)
 - updating with check constraints [27](#)
- TABLESPACE
 - clause of ALTER TABLESPACE statement [1321](#)
- TABLESPACE clause
 - DROP statement [1898](#)
- TABLESPACE privilege
 - GRANT statement [1993](#)
 - REVOKE statement [2109](#)
- TABLESTATUS column of SYSTABLES catalog table [2678](#)
- TAN function [583](#)
- TANH function [583](#)
- target variable
 - FETCH statement [1936](#)
- target-variable
 - SELECT INTO statement [2119](#)
- TARGETNAMESPACE column
 - SYSIBM.XSROBJECTCOMPONENTS table [2783](#)
 - SYSIBM.XSROBJECTHIERARCHIES table [2784](#)
 - SYSIBM.XSROBJECTS table [2782](#)
- TBCREATOR column
 - SYSCOLUMNS catalog table [2381](#)
 - SYSCOLUMNS_HIST catalog table [2395](#)
 - SYSFIELDS catalog table [2456](#)
 - SYSINDEXES catalog table [2461](#)
 - SYSINDEXES_HIST catalog table [2472](#)
 - SYSKEYCOLUSE catalog table [2497](#)
 - SYSSYNONYMS catalog table [2658](#)
 - SYSTABCONST catalog table [2664](#)
 - SYSTABLES catalog table [2678](#)
- TBNAME column
 - SYSAUXRELS catalog table [2368](#)
 - SYSCHECKDEP catalog table [2369](#)
 - SYSCHECKS catalog table [2369](#)
 - SYSCHECKS2 catalog table [2370](#)
 - SYSCOLDIST catalog table [2373](#)
 - SYSCOLDIST_HIST catalog table [2377](#)

TBNAME column (*continued*)

- SYSCOLDISTSTATS catalog table [2375](#)
- SYSCOLSTATS catalog table [2379](#)
- SYSCOLUMNS catalog table [2381](#)
- SYSCOLUMNS_HIST catalog table [2395](#)
- SYSFIELDS catalog table [2456](#)
- SYSFOREIGNKEYS catalog table [2458](#)
- SYSINDEXES catalog table [2461](#)
- SYSINDEXES_HIST catalog table [2472](#)
- SYSKEYCOLUSE catalog table [2497](#)
- SYSRELS catalog table [2613](#)
- SYSNONONYMS catalog table [2658](#)
- SYSTABCONST catalog table [2664](#)
- SYSTABLES catalog table [2678](#)
- SYSTRIGGERS catalog table [2712](#)
- SYSXMLRELS catalog table [2734](#)

TBOWNER column

- SYSAUXRELS catalog table [2368](#)
- SYSCHECKDEP catalog table [2369](#)
- SYSCHECKS catalog table [2369](#)
- SYSCHECKS2 catalog table [2370](#)
- SYSCOLDIST catalog table [2373](#)
- SYSCOLDIST_HIST catalog table [2377](#)
- SYSCOLDISTSTATS catalog table [2375](#)
- SYSCOLSTATS catalog table [2379](#)
- SYSTRIGGERS catalog table [2712](#)
- SYSXMLRELS catalog table [2734](#)

TCREATOR column of SYSTABAUTH catalog table [2659](#)

TEMPORAL_LOGICAL_TRANSACTION_TIME
built-in global variable [334](#)

TEMPORAL_LOGICAL_TRANSACTIONS
built-in global variable [334](#)

temporary
copy of table [2039](#)

temporary table
creating [1518](#), [1830](#)

terminating a utility
DSNUTILS [895](#)

TEXT column

- SYSROUTINES catalog table [2621](#)
- SYSROUTINESTEXT catalog table [2635](#)
- SYSSTMT catalog table [2651](#)
- SYSTRIGGERS catalog table [2712](#)
- SYSVIEWS catalog table [2730](#)

TEXT_ENVID column
SYSROUTINES catalog table [2621](#)

TEXT_ROWID column
SYSROUTINES catalog table [2621](#)

time

- arithmetic [261](#)
- data type [119](#)
- duration [257](#)
- strings [120](#), [124](#)

TIME

- data type
 - CREATE TABLE statement [1663](#)
 - description [119](#)
 - function [584](#)

TIME data type [20](#)

TIME FORMAT clause

- ALTER PROCEDURE (SQL - native) statement [1214](#)
- CREATE PROCEDURE (SQL - native) statement [1132](#), [1446](#), [1629](#)
- CREATE TRIGGER statement [1356](#), [1754](#)

TIME FORMAT field of panel DSNTIP4 [325](#)

time zone

- implicit [124](#)

TIME_FORMAT column
SYSENVIRONMENT catalog table [2452](#)

TIME_FORMAT session variable [336](#)

TIME_LENGTH session variable [336](#)

timestamp

- arithmetic [262](#)
- data type [119](#)
- duration [257](#)
- strings [120](#)

TIMESTAMP

- column of SYSCHECKS catalog table [2369](#)
- column of SYSCOPY catalog table [2408](#)
- column of SYSDBRM catalog table [2437](#)
- column of SYSPACKAGE catalog table [2519](#)
- column of SYSPACKAUTH catalog table [2536](#)
- column of SYSPACKLIST catalog table [2558](#)
- column of SYSRELS catalog table [2613](#)
- data type
 - CREATE TABLE statement [1663](#)
 - description [119](#)
 - function [584](#)
- TIMESTAMP data type [20](#)
- TIMESTAMP_FORMAT function [591](#)
- TIMESTAMP_ISO
function [595](#)
- TIMESTAMP_TZ
function [596](#)
- TIMESTAMPADD
function [587](#)
- TIMESTAMPDIFF
function [588](#)
- TNAME column of SYSCOLAUTH catalog table [2371](#)

TO

- clause of CONNECT statement [1409](#)

TO clause

- GRANT statement [1965](#)

TO SAVEPOINT clause
ROLLBACK statement [2111](#)

TO_CHAR function [598](#), [623](#)

TO_CLOB (character large object)
function [598](#)

TO_DATE function [591](#), [599](#)

TO_NUMBER function [599](#)

TO_TIME column
SYSINDEXCONTROL catalog table [2460](#)

TO_TIMESTAMP function [600](#)

token in SQL [75](#)

TOTALENTRIES column
SYSINDEXSPACESTATS catalog table [2482](#)

TOTALORDER function [599](#)

TOTALROWS column
SYSTABLESPACESTATS catalog table [2699](#)

TPN column
LOCATIONS catalog table [2351](#)

TRACE privilege

- GRANT statement [1986](#)
- REVOKE statement [2099](#)

TRACEAUTH column of SYSUSERAUTH catalog table [2715](#)

TRACKMOD

- clause of CREATE TABLESPACE statement [1732](#)
- column of SYSTABLEPART catalog table [2665](#)

TRACKMOD clause
 ALTER TABLESPACE statement [1330](#)
 TRACKMOD column
 SYSTABLESPACE catalog table [2688](#)
 TRACKMOD NO
 clause of CREATE TABLE statement [1701](#)
 TRACKMOD YES
 clause of CREATE TABLE statement [1701](#)
 TRANS_START column
 SYSROLES catalog table [2618](#), [2722](#)
 transactions [42](#)
 TRANSFER OWNERSHIP statement
 database objects [2172](#)
 description [2172](#)
 example [2175](#)
 system objects [2172](#)
 TRANSLATE function [600](#)
 TRANSPROC column of SYSSTRINGS catalog table [2656](#)
 TRANSTAB column of SYSSTRINGS catalog table [2656](#)
 TRANSTYPE column of SYSSTRINGS catalog table [2656](#)
 TRIGEVENT column of SYSTRIGGERS catalog table [2712](#)
 trigger
 altering [1342](#), [1365](#)
 creating [1740](#), [1769](#)
 dropping [1898](#)
 name, unqualified [86](#)
 naming convention [84](#)
 unqualified name [86](#)
 TRIGGER clause
 COMMENT statement [1404](#)
 DROP statement [1898](#)
 TRIGGER privilege
 GRANT statement [1989](#)
 REVOKE statement [2102](#)
 trigger versions
 naming convention [85](#)
 TRIGGERAUTH column
 SYSTABAUTH catalog table [2659](#)
 triggered-SQL-statement clause of TRIGGER statement [1358](#), [1757](#), [1777](#)
 triggers
 overview [32](#)
 TRIGTIME column of SYSTRIGGERS catalog table [2712](#)
 TRIM function [603](#)
 TRIM_ARRAY function [605](#)
 TRUNC function [606](#)
 TRUNC_TIMESTAMP function [607](#)
 TRUNCATE function [606](#)
 TRUNCATE statement
 description [2175](#)
 examples [2178](#)
 truncation
 numbers [145](#)
 TRUSTED column
 LOCATIONS catalog table [2351](#)
 trusted context
 altering [1368](#)
 defining [1787](#)
 TRUSTED CONTEXT clause
 COMMENT statement [1404](#)
 DROP statement [1898](#)
 truth table [319](#)
 truth valued logic [319](#)
 TSNAME column
 SYSCOPY catalog table [2408](#)
 SYSTABLEPART catalog table [2665](#)
 SYSTABLEPART_HIST catalog table [2675](#)
 SYSTABLES catalog table [2678](#)
 SYSTABLES_HIST catalog table [2707](#)
 SYSTABSTATS catalog table [2710](#)
 SYSTABSTATS_HIST catalog table [2711](#)
 TTNAME column of SYSTABAUTH catalog table [2659](#)
 TTYPE column
 SYSCOPY catalog table [2408](#)
 two-phase commit [68](#)
 TYPE clause
 COMMENT statement [1404](#)
 DROP statement [1898](#)
 TYPE column
 SYSCOLDIST catalog table [2373](#)
 SYSCOLDIST_HIST catalog table [2377](#)
 SYSCOLDISTSTATS catalog table [2375](#)
 SYSDATABASE catalog table [2427](#)
 SYSINDEXCONTROL catalog table [2460](#)
 SYSKEYTGTDIST catalog table [2509](#)
 SYSKEYTGTDIST_HIST catalog table [2513](#)
 SYSKEYTGTDISTSTATS catalog table [2511](#)
 SYSPACKAGE catalog table [2519](#)
 SYSTABCONST catalog table [2664](#)
 SYSTABLES catalog table [2678](#)
 SYSTABLESPACE catalog table [2688](#)
 USERNAMES catalog table [2737](#)
 typed parameter marker [2051](#)
 typed-correlation-clause
 description [1029](#)
 TYPENAME column
 SYSCOLUMNS catalog table [2381](#)
 SYSKEYTARGETS catalog table [2500](#)
 SYSKEYTARGETS_HIST catalog table [2505](#)
 SYSPARMS catalog table [2565](#)
 SYSVARIABLES catalog table [2724](#)
 TYPESCHEMA column
 SYSCOLUMNS catalog table [2381](#)
 SYSKEYTARGETS catalog table [2500](#)
 SYSKEYTARGETS_HIST catalog table [2505](#)
 SYSPARMS catalog table [2565](#)
 SYSVARIABLES catalog table [2724](#)

U

UCASE function [610](#), [612](#)
 unary operation [250](#)
 UNCOMPRESSED DATASIZE column
 SYSTABLESPACESTATS catalog table [2699](#)
 unconnectable and connected state [72](#)
 unconnectable and unconnected state [72](#)
 unconnected state [71](#)
 Unicode
 definition [59](#)
 effect on MBCS and DBCS characters [104](#)
 encoding schemes [17](#)
 Unicode column in an EBCDIC table
 migration to Db2 [12](#) [115](#)
 UNICODE function [610](#)
 UNICODE_STR function [611](#)
 UNION clause
 duplicate rows [1061](#)

- UNION clause (*continued*)
 - fullselect [1061](#)
- UNIQUE clause
 - ALTER TABLE statement [1268](#)
 - CREATE INDEX statement [1530](#)
 - CREATE TABLE statement [1668](#), [1681](#)
 - SAVEPOINT statement [2113](#)
- unique constraints [11](#), [12](#)
- unique indexes [10](#)
- unique keys [10](#)
- UNIQUE_COUNT column
 - SYSINDEXES catalog table [2461](#)
- UNIQUERULE
 - SYSINDEXES catalog table [2461](#)
- UNISTR function [611](#)
- unit of recovery
 - COMMIT statement [1406](#)
 - ROLLBACK statement [2110](#)
- unit of work
 - closes cursors [2039](#)
 - ending [43](#), [55](#), [1406](#), [2110](#)
 - initiating [43](#), [55](#)
 - referring to prepared statements [2042](#)
- universal table spaces (UTS) [50](#)
- universal time, coordinated (UTC) [179](#)
- UNLOAD privilege
 - GRANT statement [1989](#)
 - REVOKE statement [2102](#)
- UNNEST
 - description [1031](#)
- UNPACK function [696](#)
- unqualified object names
 - resolution [86](#)
- unsupported data types
 - SQLDA [2325](#)
- untyped parameter marker [2051](#)
- UPDATE
 - clause of TRIGGER statement [1348](#), [1757](#), [1776](#)
 - statement
 - description [2178](#)
 - example [2196](#)
- UPDATE privilege
 - GRANT statement [1989](#)
 - REVOKE statement [2102](#)
- update rule [2190](#)
- UPDATE statement
 - updates and check constraints [27](#)
- UPDATEAUTH column of SYSTABAUTH catalog table [2659](#)
- UPDATECOLS column of SYSTABAUTH catalog table [2659](#)
- UPDATES column
 - SYSCOLUMNS catalog table [2381](#)
- UPDATESTATSTIME column
 - SYSINDEXSPACESTATS catalog table [2482](#)
 - SYSTABLESPACESTATS catalog table [2699](#)
- updating
 - rows in a table [2178](#)
- UPPER function [612](#)
- URLDECODE function [2963](#)
- URLENCODE function [2963](#)
- USAGE privilege
 - GRANT statement [1979](#), [1991](#)
 - REVOKE statement [2093](#), [2104](#)
- USEAUTH
 - column of SYSSEQUENCEAUTH catalog table [2640](#)
- USEAUTH column of SYSRESAUTH catalog table [2615](#)
- USER [215](#)
- USER clause
 - SET PATH statement [2164](#)
- USER special register [214](#)
- user-defined data types [126](#)
- user-defined default values [25](#)
- user-defined function
 - altering with ALTER FUNCTION (inlined SQL scalar) statement [1142](#)
 - altering with ALTER FUNCTION statement [1097](#), [1113](#)
 - changing with ALTER FUNCTION statement [1150](#)
 - creating with CREATE FUNCTION (inlined SQL scalar) statement [1489](#)
 - creating with CREATE FUNCTION statement [1424](#), [1428](#), [1453](#), [1472](#), [1498](#), [1510](#)
 - dropping [1892](#)
 - privileges
 - revoking [2081](#)
 - statements allowed [2275](#)
- user-defined function (UDF)
 - description [238](#)
 - external functions [238](#)
 - IBM MQ functions [341](#)
 - inheriting special registers [215](#)
 - invocation [242](#)
 - name, unqualified [86](#)
 - naming convention [81](#)
 - resolution [239](#)
 - sample
 - ALTDAT [2941](#)
 - ALTTIME [2943](#)
 - BASE64DECODE [2945](#)
 - BASE64ENCODE [2945](#)
 - CURRENCY [2945](#)
 - DAYNAME [2946](#)
 - HDFS_READ [2947](#)
 - HTTPBLOB [2948](#)
 - HTTPCLOB [2949](#)
 - HTTPDELETEDBLOB [2950](#)
 - HTTPDELETEDCLOB [2950](#)
 - HTTPGETBLOB [2952](#)
 - HTTPGETBLOBFILE [2954](#)
 - HTTPGETCLOB [2952](#)
 - HTTPGETCLOBFILE [2954](#)
 - HTTPHEAD [2955](#)
 - HTTPPOSTBLOB [2956](#)
 - HTTPPOSTCLOB function [2956](#)
 - HTTPPUTBLOB [2957](#)
 - HTTPPUTCLOB [2957](#)
 - JAQL_SUBMIT [2958](#)
 - MONTHNAME [2959](#)
 - TABLE_LOCATION [2960](#)
 - TABLE_NAME [2961](#)
 - TABLE_SCHEMA [2962](#)
 - URLDECODE [2963](#)
 - URLENCODE [2963](#)
 - WEATHER [2964](#)
 - sourced functions [238](#)
 - table functions [238](#)
 - unqualified name [86](#)
 - version resolution [243](#)
- user-defined functions
 - samples

user-defined functions (*continued*)

samples (*continued*)

ALTDAT [20](#)

ALTTIME [20](#)

user-defined session variables [227](#)

user-defined type

assignment of values [153](#)

comparison of values [164](#)

dropping [1898](#)

user-defined types [35](#)

USERNAMES column

IPNAMES catalog table [2349](#)

LUNAMES catalog table [2354](#)

USING clause

ALTER INDEX statement [1163](#), [1165](#)

ALTER TABLESPACE statement [1332](#)

CREATE INDEX statement [1538](#), [1539](#)

CREATE LOB TABLESPACE statement [1559](#)

CREATE TABLESPACE statement [1732](#)

DESCRIBE statement [1874](#), [1882](#)

EXECUTE statement [1910](#)

OPEN statement [2038](#)

PREPARE statement [2044](#)

USING DESCRIPTOR clause

EXECUTE statement [1911](#)

OPEN statement [2039](#)

USING host-variable-array

clause

EXECUTE statement [1911](#)

USING TYPE DEFAULTS clause

CREATE TABLE statement [1689](#)

DECLARE GLOBAL TEMPORARY TABLE statement [1838](#)

UTC (universal time, coordinated) [179](#)

UTF-16 [59](#)

UTF-8 [59](#)

V

VALID

column of SYSDYNQRY catalog table [2444](#)

VALID column

SYSPACKAGE catalog table [2519](#)

SYSPLAN catalog table [2575](#)

VALIDATE

column of SYSPACKAGE catalog table [2519](#)

column of SYSPLAN catalog table [2575](#)

VALIDATE clause

ALTER PROCEDURE (SQL - native) statement [1213](#)

CREATE PROCEDURE (SQL - native) statement [1131](#),
[1445](#), [1628](#)

validation procedure [1292](#)

validation routine

VALIDPROC clause [1292](#), [1697](#)

VALIDPROC clause

ALTER TABLE statement [1292](#)

CREATE TABLE statement [1697](#)

VALPROC column of SYSTABLES catalog table [2678](#)

value

SQL [98](#)

VALUE column

SYSCTXTTRUSTATTRS catalog table [2426](#)

VALUE function [166](#), [417](#), [479](#), [614](#)

VALUES clause

CREATE INDEX statement [1551](#)

VALUES clause (*continued*)

CREATE TABLE statement [1714](#)

INSERT statement [2001](#), [2004](#)

VALUES INTO statement [2201](#)

VALUES statement [2199](#)

VALUES INTO statement

description [2200](#)

example [2203](#)

VALUES statement

description [2199](#)

example [2200](#)

VAR function [379](#)

VAR_POP function [379](#)

VAR_SAMP function [380](#)

VARBINARY

data type

description [116](#)

function [614](#)

VARCHAR

data type

CREATE TABLE statement [1663](#)

description [103](#)

function [615](#)

VARCHAR_BIT_FORMAT scalar function [622](#)

VARCHAR_FORMAT function [623](#)

VARGRAPHIC

data type

CREATE TABLE statement [1663](#)

description [112](#)

function [632](#)

variable

built-in global

CATALOG_LEVEL [329](#)

CLIENT_IPADDR [330](#)

DEFAULT_SQLLEVEL [330](#)

GET_ARCHIVE [330](#)

MAX_LOCKS_PER_TABLESPACE [331](#)

MAX_LOCKS_PER_USER [331](#)

MOVE_TO_ARCHIVE [332](#)

PRODUCTID_EXT [332](#)

referencing [329](#)

REPLICATION_OVERRIDE [333](#)

TEMPORAL_LOGICAL_TRANSACTION_TIME [334](#)

TEMPORAL_LOGICAL_TRANSACTIONS [334](#)

built-in session

referencing [329](#), [336](#)

description [225](#)

global [225](#)

global variable [225](#)

host

referencing [227](#)

SQL syntax [227](#)

PREPARE statement [2050](#)

referencing [225](#)

SQL syntax [225](#)

substitution for parameter markers [1910](#)

XML [231](#)

VARIABLE clause

COMMENT statement [1404](#)

DECLARE VARIABLE statement [1850](#)

variables

session [227](#)

VARIANCE function [379](#)

VARIANCE_SAMP function [380](#)

VARIANT clause
 CREATE PROCEDURE (external) statement [1596](#)
 CREATE PROCEDURE (SQL - external) statement [1606](#)
 CREATE PROCEDURE (SQL - native) statement [1635](#)

VARID column
 SYSVARIABLES catalog table [2724](#)

VCAT
 USING clause
 ALTER INDEX statement [1163](#)
 CREATE INDEX statement [1165](#), [1538](#), [1540](#)
 CREATE LOB TABLESPACE statement [1559](#)
 CREATE TABLESPACE statement [1732](#)

VCAT clause
 ALTER TABLESPACE statement [1332](#)
 CREATE STOGROUP statement [1646](#)

VCATNAME column
 SYSINDEXES catalog table [2461](#)
 SYSINDEXPART catalog table [2474](#)
 SYSSTOGROUP catalog table [2655](#)
 SYSTABLEPART catalog table [2665](#)
 SYSTABLESPACE catalog table [2688](#)

VERIFY_GROUP_FOR_USER function [637](#)
 VERIFY_ROLE_FOR_USER function [638](#)
 VERIFY_TRUSTED_CONTEXT_ROLE_FOR_USER function [640](#)

VERSION
 column of SYSDBRM catalog table [2437](#)
 column of SYSPACKAGE catalog table [2519](#)
 column of SYSPACKSTMT catalog table [2558](#)

VERSION clause
 COMMENT statement [1403](#)
 CREATE PROCEDURE (SQL - native) statement [1617](#)
 DROP statement [1895](#)

VERSION column
 SYSINDEXES catalog table [2461](#)
 SYSPARMS catalog table [2565](#)
 SYSROUTINES catalog table [2621](#)
 SYSTABLES catalog table [2678](#)

version resolution [243](#)

VERSION session variable [336](#)

view
 creating
 CREATE VIEW statement [1812](#)
 dropping
 description [1899](#)
 name, unqualified [86](#)
 naming convention [85](#)
 privileges
 granting [1988](#)
 regenerating
 ALTER VIEW statement [1378](#)
 unqualified name [86](#)
 using
 read-only [1817](#)

VIEW clause
 CREATE VIEW statement [1812](#)
 DROP statement [1899](#)

views
 overview [30](#)

VOLATILE
 clause of CREATE TABLE statement [1699](#)

VOLATILE clause
 ALTER TABLE statement [1288](#)

VOLID column of SYSVOLUMES catalog table [2733](#)

VOLUMES clause

VOLUMES clause (*continued*)
 CREATE STOGROUP statement [1646](#)
 VSAM (virtual storage access method)
 catalog [1540](#)

W

WEATHER function [2964](#)
 WEEK function [641](#)
 WEEK_ISO function [642](#)
 WHEN clause of TRIGGER statement [1358](#), [1757](#), [1776](#)
 WHEN MATCHED clause
 MERGE statement [2026](#)
 WHEN NOT MATCHED clause
 MERGE statement [2026](#)
 WHENEVER statement
 description [2204](#)
 example [2205](#)
 WHERE clause
 DELETE statement [1861](#)
 description [1036](#)
 search condition [1036](#)
 UPDATE statement [2188](#)
 WHERE CURRENT OF clause
 DELETE statement [1862](#)
 UPDATE statement [2189](#)
 WHILE statement
 example [2245](#), [2302](#)
 SQL procedure [2245](#), [2302](#)
 WITH AUTHENTICATION clause
 ALTER TRUSTED CONTEXT statement [1376](#)
 CREATE TRUSTED CONTEXT statement [1792](#), [1793](#)
 WITH CHECK OPTION clause of CREATE VIEW statement [1815](#)
 WITH clause
 select-statement [1073](#)
 WITH common-table-expression clause
 select-statement [1069](#)
 WITH common-table-expression clause of CREATE VIEW statement [1815](#)
 WITH EXPLAIN clause
 ALTER PROCEDURE (SQL - native) statement [1207](#)
 CREATE PROCEDURE (SQL - native) statement [1127](#), [1441](#), [1622](#)
 CREATE TRIGGER statement [1353](#), [1751](#)
 WITH GRANT OPTION clause
 GRANT statement [1966](#)
 WITH HOLD clause of DECLARE CURSOR statement [1822](#)
 WITH IMMEDIATE WRITE clause
 ALTER PROCEDURE (SQL - native) statement [1208](#)
 CREATE PROCEDURE (SQL - native) statement [1127](#), [1441](#), [1623](#)
 CREATE TRIGGER statement [1353](#), [1752](#)
 WITH KEEP DYNAMIC clause
 ALTER PROCEDURE (SQL - native) statement [1209](#)
 CREATE PROCEDURE (SQL - native) statement [1623](#)
 WITH PROCEDURE clause of ASSOCIATE LOCATORS statement [1380](#)
 WITH RETURN clause of DECLARE CURSOR statement [1823](#)
 WITH RETURN clause of PREPARE statement [2047](#)
 WITH ROWSET POSITIONING clause
 DECLARE CURSOR statement [1824](#)
 PREPARE statement [2047](#)
 WITH USE FOR clause

WITH USE FOR clause (*continued*)
 CREATE TRUSTED CONTEXT statement [1792](#)

WITHOUT AUTHENTICATION clause
 ALTER TRUSTED CONTEXT statement [1376](#)
 CREATE TRUSTED CONTEXT statement [1792](#), [1793](#)

WITHOUT EXPLAIN clause
 ALTER PROCEDURE (SQL - native) statement [1207](#)
 CREATE PROCEDURE (SQL - native) statement [1127](#),
[1441](#), [1622](#)
 CREATE TRIGGER statement [1353](#), [1751](#)

WITHOUT HOLD clause of DECLARE CURSOR statement
[1822](#)

WITHOUT IMMEDIATE WRITE clause
 ALTER PROCEDURE (SQL - native) statement [1208](#)
 CREATE PROCEDURE (SQL - native) statement [1127](#),
[1441](#), [1623](#)
 CREATE TRIGGER statement [1353](#), [1752](#)

WITHOUT KEEP DYNAMIC clause
 ALTER PROCEDURE (SQL - native) statement [1209](#)
 CREATE PROCEDURE (SQL - native) statement [1623](#)

WITHOUT RETURN clause of DECLARE CURSOR statement
[1823](#)

WITHOUT RETURN clause of PREPARE statement [2047](#)

WITHOUT ROWSET POSITIONING clause
 DECLARE CURSOR statement [1824](#)
 PREPARE statement [2047](#)

WLM ENVIRONMENT clause
 ALTER FUNCTION statement [1109](#)
 ALTER PROCEDURE (external) statement [1186](#)
 ALTER PROCEDURE (SQL - external) statement [1192](#)
 CREATE FUNCTION statement [1468](#), [1485](#)
 CREATE PROCEDURE (external) statement [1593](#)
 CREATE PROCEDURE (SQL - external) statement [1604](#)

WLM ENVIRONMENT FOR DEBUG MODE clause
 ALTER PROCEDURE (SQL - native) statement [1205](#)
 CREATE PROCEDURE (SQL - native) statement [1125](#),
[1439](#), [1620](#)
 CREATE TRIGGER statement [1351](#), [1750](#)

WLM_ENV_FOR_NESTED column of SYSROUTINES catalog
 table [2621](#)

WLM_ENVIRONMENT column
 SYSTRIGGERS catalog table [2712](#)

WLM_ENVIRONMENT column of SYSROUTINES catalog table
[2621](#)

WLM_REFRESH stored procedure
 description [997](#)
 option descriptions [997](#)
 sample JCL [998](#)
 syntax diagram [997](#)

WLM_SET_CLIENT_INFO procedure [999](#)

work file database
 creating [1422](#)
 description [42](#)

WORKAREA column of SYSFIELDS catalog table [2456](#)

WRITEAUTH column
 SYSVARIABLEAUTH catalog table [2722](#)

X

XML
 assignment of values [153](#)
 comparison of values [159](#)
 data type
 CREATE TABLE statement [1663](#)

XML (*continued*)
 variable [231](#)

XML (Extensible Markup Language) [21](#)

XML operands [169](#)

XML pattern expression clause
 CREATE INDEX statement [1534](#)

XML schema registration
 XSR_ADDSCHEMADOC stored procedure [1000](#)
 XSR_COMPLETE stored procedure [1002](#)
 XSR_REMOVE stored procedure [1005](#)

XML schema repository
 description [2779](#)

XML schema repository tables
 indexes [2779](#)
 table space [2779](#)
 XSRANNOTATIONINFO [2780](#)
 XSRCOMPONENT [2781](#)
 XSROBJECTCOMPONENTS [2783](#)
 XSROBJECTGRAMMAR [2784](#)
 XSROBJECTHIERARCHIES [2784](#)
 XSROBJECTPROPERTY [2785](#)
 XSROBJECTS [2782](#)
 XSRPROPERTY [2785](#)

XML schema repository, DB2
 tables [2779](#)

XML table spaces [50](#)

XML values
 data type [125](#)

XML-attribute
 naming convention [85](#)

XML-element
 naming convention [85](#)

XMLAGG function [381](#)

XMLATTRIBUTES function [644](#)

XMLCAST specification
 description [277](#)

XMLCOMMENT function [645](#)

XMLCONCAT function [645](#)

XMLDOCUMENT function [646](#)

XMLELEMENT function [647](#)

XML EXISTS
 predicate [316](#)

XMLFOREST function [651](#)

XMLMODIFY
 function [653](#)

XMLNAMESPACES function [656](#)

XMLPARSE function [657](#)

XMLPATTERN clause
 CREATE INDEX statement [1534](#)

XMLPI function [659](#)

XMLQUERY function [659](#)

XMLRELOBID column
 SYSXMLRELS catalog table [2734](#)

XMLSCHEMA
 data type
 CREATE TABLE statement [1663](#)

XMLSERIALIZE function [662](#)

XMLTABLE table function
 description [693](#)

XMLTBNAME column
 SYSXMLRELS catalog table [2734](#)

XMLTBOWNER column
 SYSXMLRELS catalog table [2734](#)

XMLTEXT function [665](#)

XMLXSROBJECTID function [666](#)
XSLTRANSFORM function [667](#)
XSR, *See* XML schema repository
XSR_COMPLETE stored procedure [1002](#)
XSR_REGISTER
 register XML schema [1003](#)
XSRCOMPONENTID column
 SYSIBM.XSROBJECTCOMPONENTS table [2783](#)
 SYSIBM.XSROBJECTHIERARCHIES table [2784](#)
XSROBJECTID column
 SYSIBM.XSROBJECTHIERARCHIES table [2784](#)
 SYSIBM.XSROBJECTS table [2782](#)
XSROBJECTNAME column
 SYSIBM.XSROBJECTS table [2782](#)
XSROBJECTSCHEMA column
 SYSIBM.XSROBJECTS table [2782](#)

Y

YEAR function [668](#)



Product Number: 5650-DB2
5770-AF3

SC27-8859-02

