



# Journée Technologique

## Le 13 janvier – Nicolas Mahé

La convergence des réseaux dans le  
BladeCenter IBM





# La Convergence, on en parle, on s'y prépare

- HP rachète 3 Com
  - Annonce de la fin des accords EOM network dans sa gamme Blade System
- Cisco Annonce UCS et se lance sur le marché du Blade
  - Fin de la collaboration avec HP & Dell
- IBM rachète Blade Network technologie
  - Continuité de l'écosystème network & annonce d'une gamme de switch « converged » EOM (Cisco, BNT, Brocade ...)



# Pourquoi parler de convergence ? (1)

La virtualisation est devenu la norme

Avant



1 OS  
2 Liens IP  
2 Liens SAN

Maintenant



1 Hyperviseur  
+10 OS  
n Liens IP  
n Liens SAN



# Pourquoi parler de convergence ? (2)

Le Blade s'impose dans plus de 30% des cas



La structure Standard =

HBA Dédiés

Max :4 à 6 x 1 Gb LAN

Max :2 à 4 x 8 GB SAN

Soit un total de 22 Gb de bande passante par châssis

---

L'infra réseau nécessaire =

+ de flexibilité

Soit 20 Gb de bande passante Flexible



# La convergence en 1 Slide

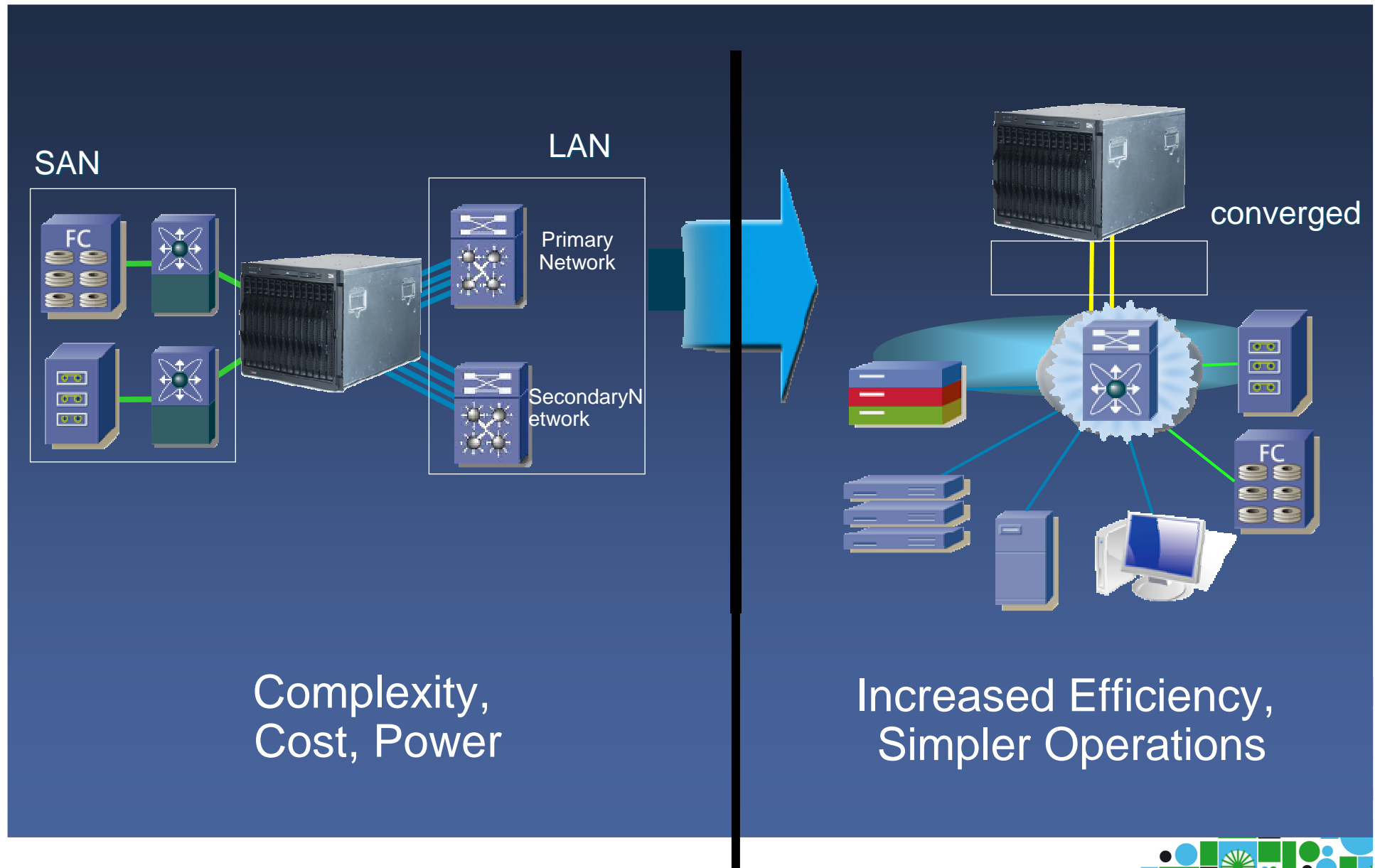

Complexity,  
Cost, Power

Increased Efficiency,  
Simpler Operations

# De quoi ai je besoin dans les serveurs ?

**Maintenant:** 4 adaptateurs par serveur

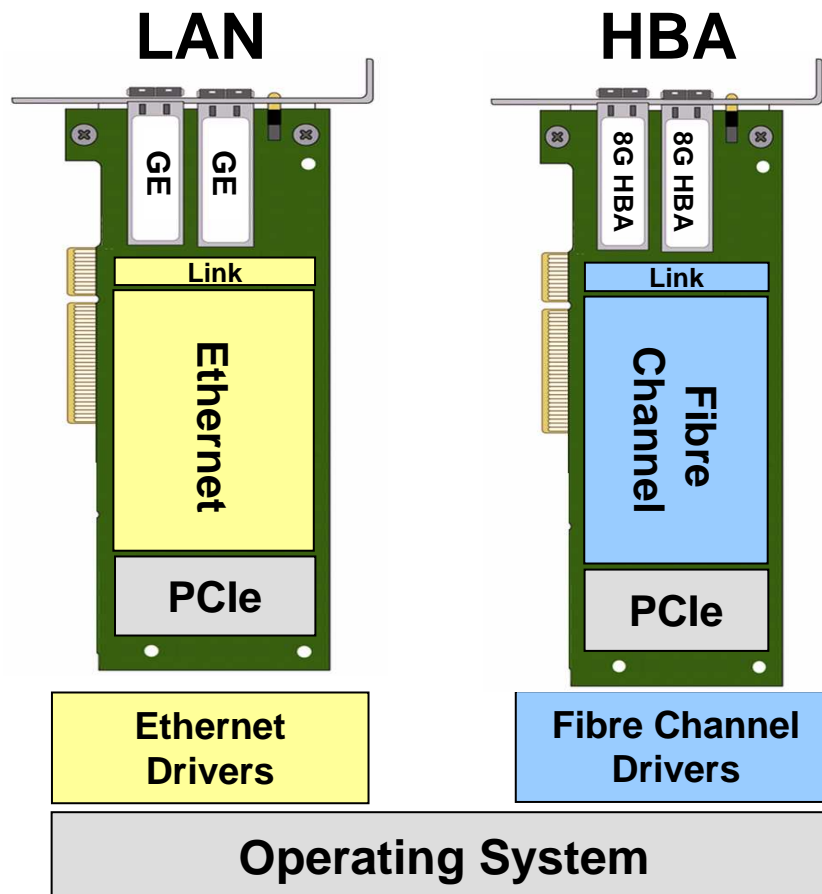

**Après:** 2 adaptateurs CAN par serveur

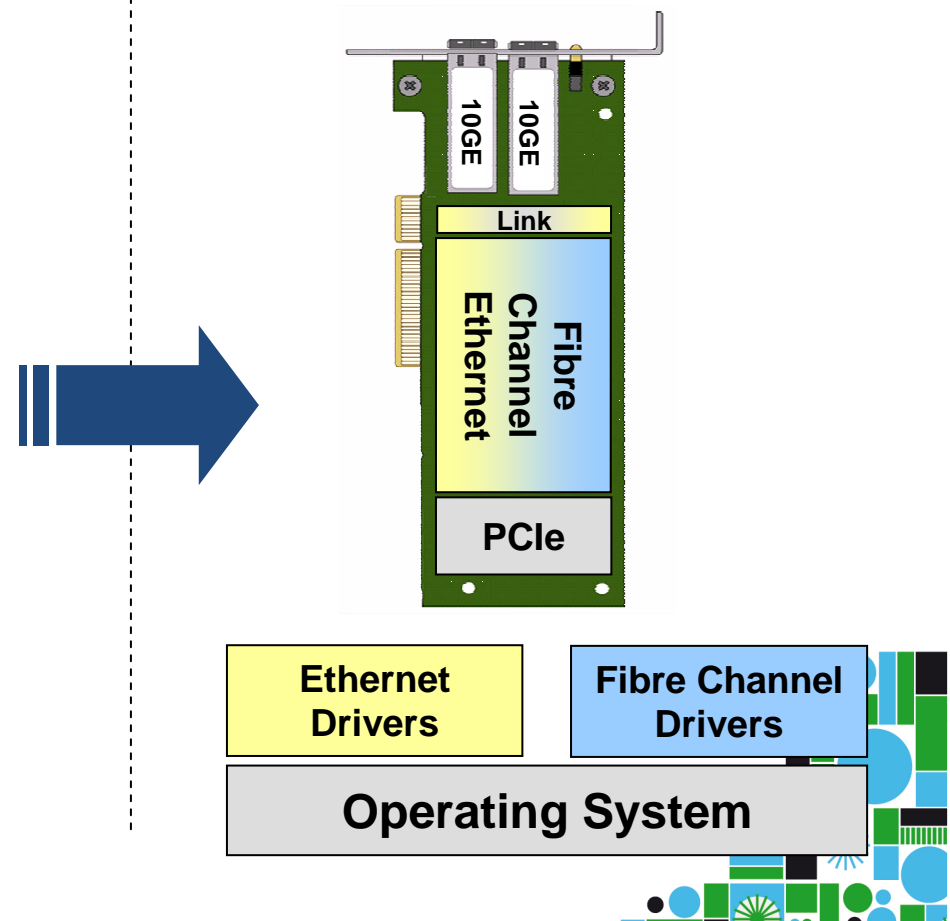

# De quoi ai-je besoin dans le châssis ?

La gamme switch 10 Gb Ethernet chez IBM



10Gb Ethernet  
Pass-Thru Module



BNT 6-port 10Gb  
Ethernet Switch  
Module



Brocade Converged 10  
Gb 30-ports



Cisco Systems  
Nexus 4001

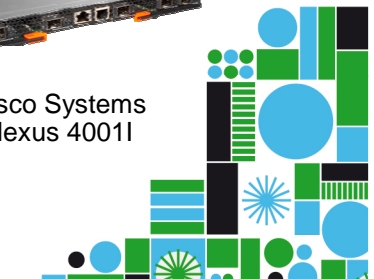



# Comparatif des configurations IO BladeCenter

	Châssis IO traditionnelles Gigabit Ethernet et Fibre Channel	Châssis 10Gb Ethernet + Fibre Channel	Châssis 10 Gb FCoE
Nombre de commutateurs Gigabit Ethernet	6		
Nombre de commutateurs Fibre Channel 8 Gb	2	2	
Nombre de commutateurs 10 Gb Ethernet		2	
Nombre de commutateurs FCoE			2
Bande passante agrégée théorique par lame en Gb	22	36	20
Oversubscription Ethernet	3,5:1	2,33:1 (Cisco Nexus) / 1,2:1 (BNT)	2,33:1 (Cisco Nexus) / 1,2:1 (BNT)
Consommation électrique par châssis en Watts	3214	3142	2916
Consommation électrique par châssis base 100	100	98	91

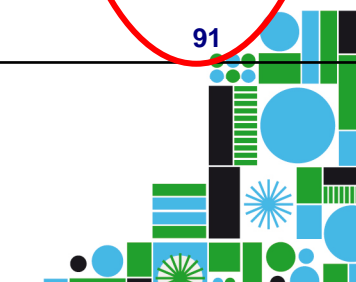

# Les implémentations 10 Gb Eth & FCoE dans le châssis BladeCenter H

Pass-Thru ou Cisco Nexus 4000 ou BNT 10Gb



## 1 “Convergence Ready”

- Most affordable first step
- 10GE NIC or CNAs handle LAN traffic only
- Full CEE bandwidth out of BC – easy migration to future FCoE

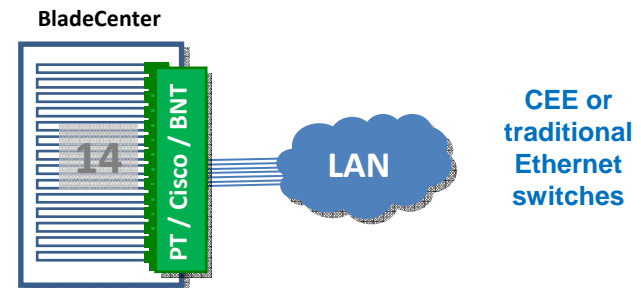

## 2 External FCoE TOR

- High-performance FCoE
- CNAs handle LAN and SAN traffic
- TOR provides FCoE/CEE switching
- Pass-Thru provides maximum CEE bandwidth and flexibility

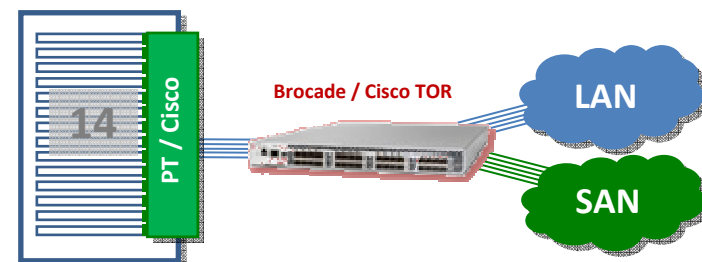

VFEM



## 3 100% Internal FCoE

- Most affordable FCoE solution
- CNAs handle LAN and SAN traffic
- Same FC connectivity as current 6-port FC standalone blades
- Manage using BladeCenter tools
- Transparent attach to any SAN

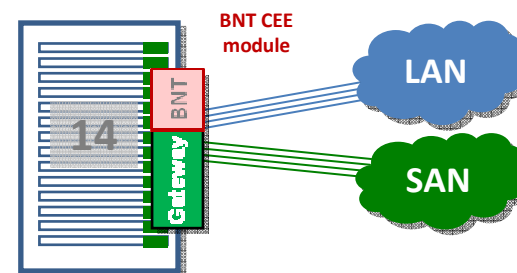

CEE access to LAN and SAN without external switches!



# IBM BladeCenter, Virtual Fabric from BNT

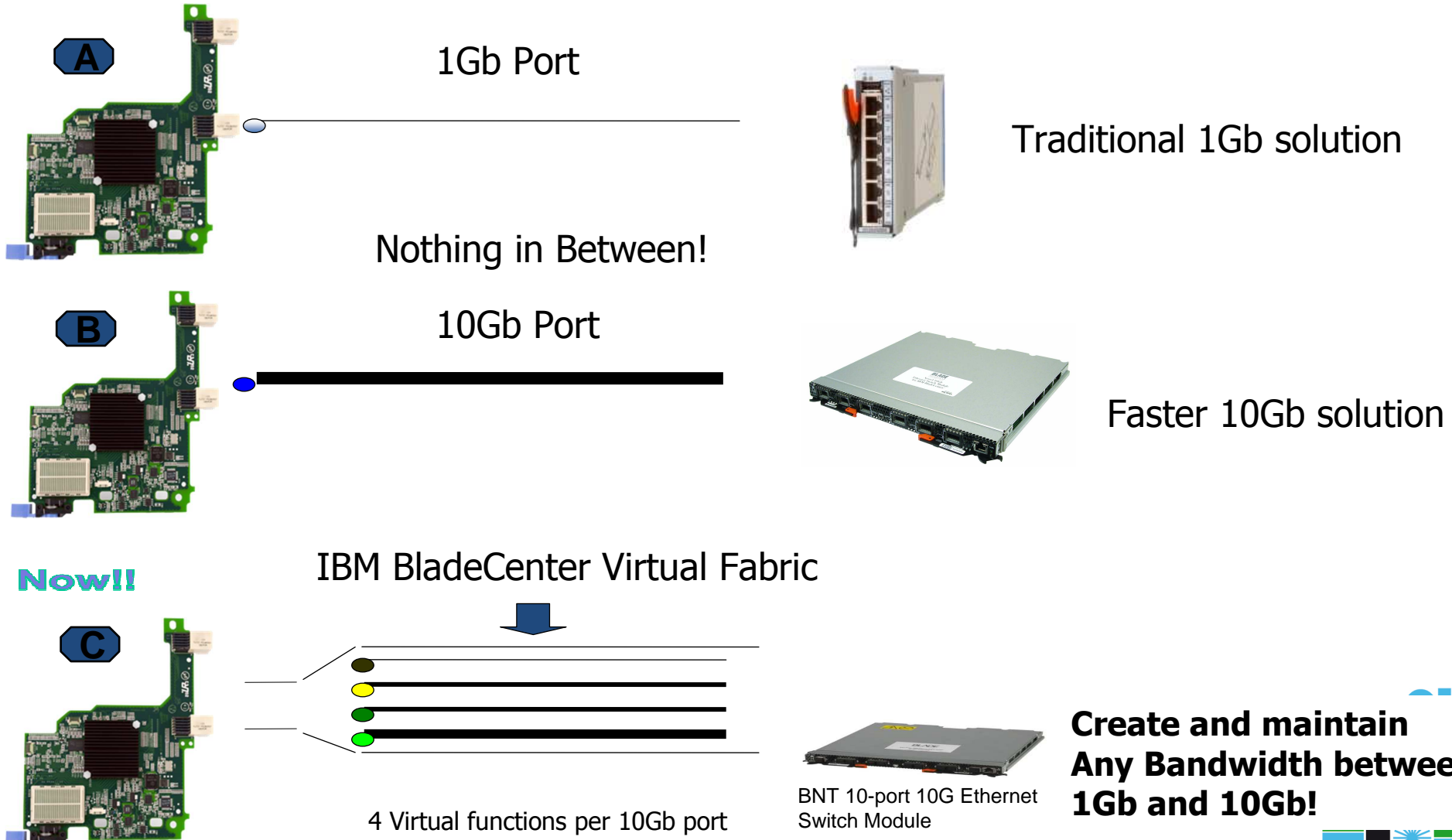

# La convergence avec l'offre Cisco Nexus

Coeur de réseau: Catalyst 6500 ou Nexus 7000

Top of Rack : Nexus 5000 (gateway LAN & SAN)

Blade switch: Nexus 4000 pour BladeCenter H

Switch virtuel : Nexus 1000v pour VMWare vSphere

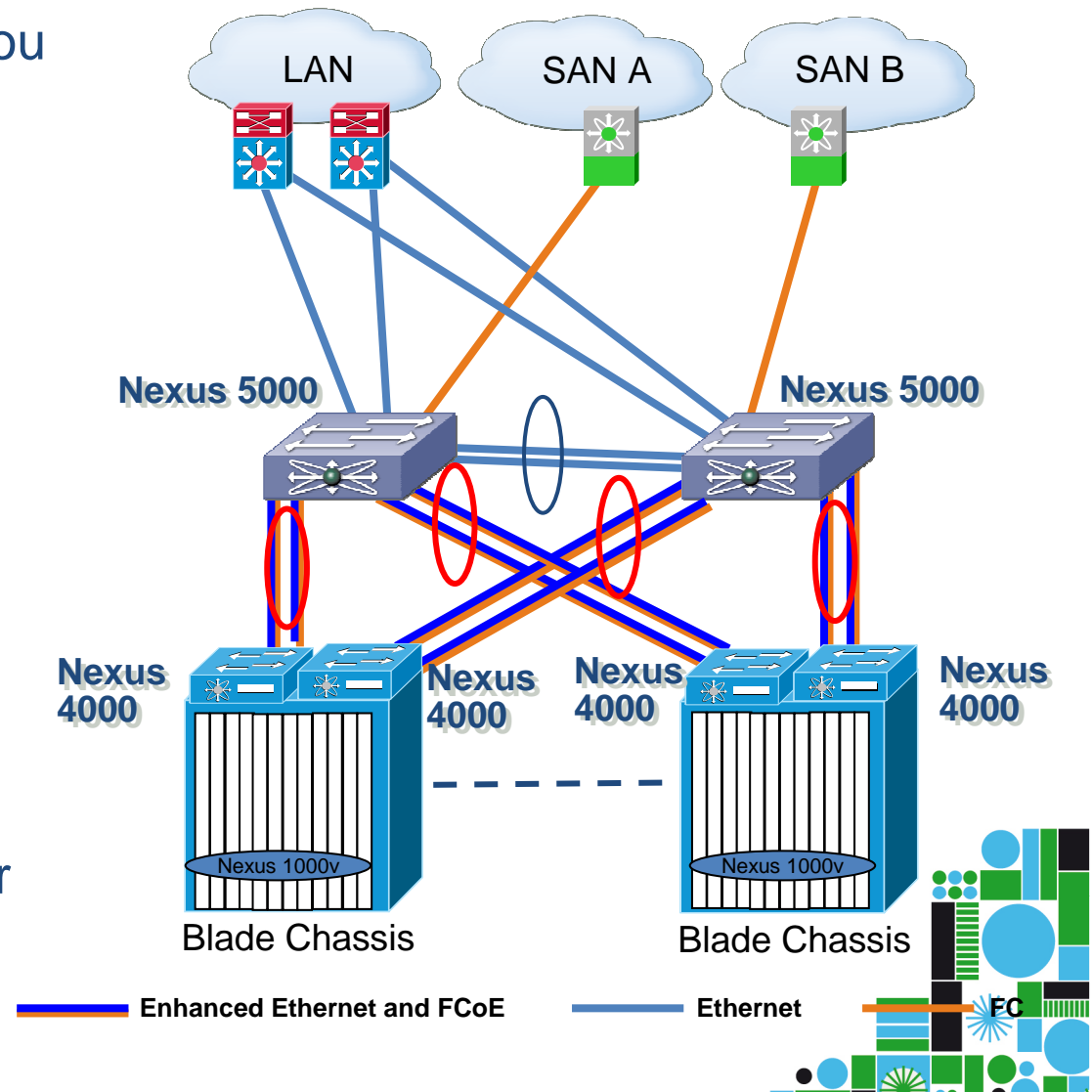

# BladeCenter Converged avec Brocade



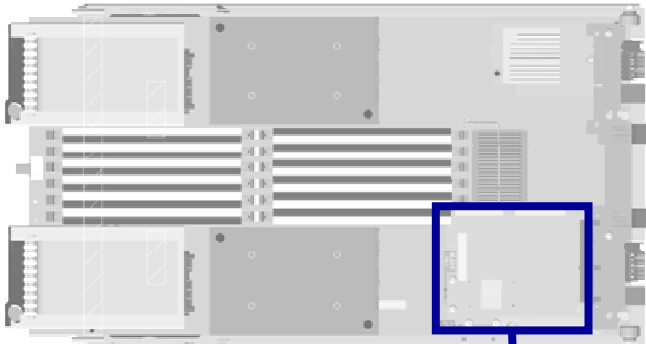

BladeCenter Server Unit



1x Brocade CNA  
2 port  
10Gb Ethernet

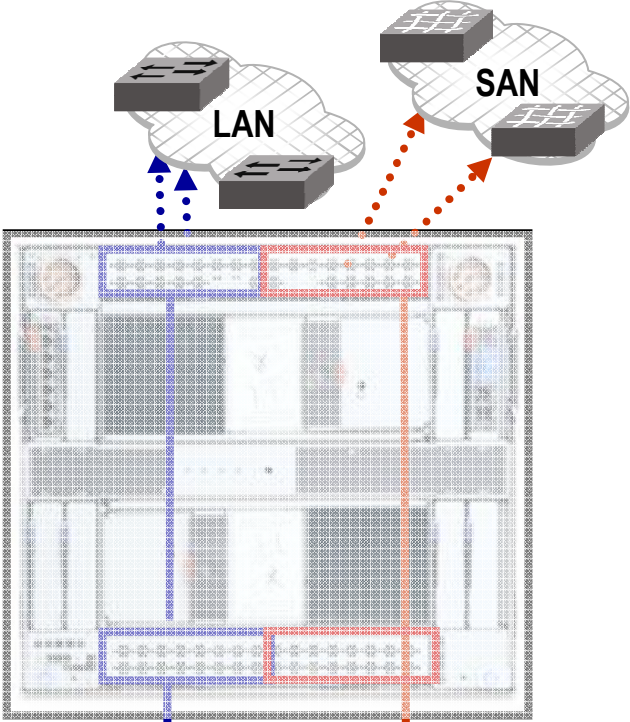

2 x Brocade  
Converged Switch  
8 Enet- / 8 FC-port



# Comparatif Prix

Exemple pour la solution Brocade

- Solution « traditionnelle »
  - Cout Connection par Lame
    - 1 326 €
  - Cout Chassis
    - 43 510 €
- Solution 10 Gb « Converged »
  - Cout Connection par Lame
    - 1 170 €
  - Cout Chassis
    - 27 510 €

